

# **TOSHIBA**

---

# *Carrier*



## ***Vertical Air Handling Unit*** **Installation, Operation and Maintenance Manual**

---

Model name:

**For Commercial Use**

---

**MMD-AP0120VHG2UL**  
**MMD-AP0180VHG2UL**  
**MMD-AP0240VHG2UL**  
**MMD-AP0300VHG2UL**  
**MMD-AP0360VHG2UL**  
**MMD-AP0420VHG2UL**  
**MMD-AP0480VHG2UL**  
**MMD-AP0600VHG2UL**



THIS PAGE INTENTIONALLY LEFT BLANK

**MMD Series Air Handling Unit**  
**Installation, Operation and Maintenance Manual**

# Installation, Start-Up and Service Instructions

<b>Topic</b>	<b>Page</b>
SAFETY CONSIDERATIONS	5
PRODUCT NOMENCLATURE	6
ACCESSORIES	7
UNPACKING	8
INSTALLATION	8
Pre-installation	8
Rigging	8
Service Clearances	8,10
Return Air & Unit Orientation	9
Unit Suspension or Floor Mount	8,11,12
Condensate Drain	11
Ductwork	11
Refrigerant Piping	13
Electric Heater Accessory	14-16
Electrical	17-20
START-UP	21
SERVICE	22-25
Fan & Fan Motor	22-23
Filters	24
Access Panels	24
Coil & Drain Pan Service	25
AIRFLOW DATA	26-27
ELECTRICAL RATINGS	28
DIMENSIONS	29-30
SPECIAL FACTORY OPTIONS	31
SPECIAL INSTRUCTIONS	32-41
Electrical	32-34
Controls	35-44
REFRIGERANT LEAKAGE WARNINGS	45
REPLACEMENT PARTS	46-55
STARTUP REPORT	57

THIS PAGE INTENTIONALLY LEFT BLANK

## GENERAL INFORMATION

### GENERAL

Installation and maintenance are to be performed **only** by qualified personnel who are familiar with local codes and regulations and are experienced with HVAC equipment of this type.

**WARNING: Sharp edges, coil surfaces and rotating fans are a potential injury hazard – avoid contact.**

**WARNING: Hazardous voltage – Disconnect and Lock Out all incoming power sources before servicing or installing unit. ELECTRIC SHOCK CAN CAUSE DEATH.**

**WARNING: This equipment may be installed well above finished floor—Use extreme caution when working at heights.**

### SAFETY WARNING:

Installer should pay particular attention to the following words:

**NOTE**—intended to clarify or make installation easier.

**CAUTION**—given to prevent equipment damage.

**WARNING**—to alert installer that personal injury and/or equipment damage may result if installation procedure is not properly followed.

### DANGER

NEVER enter an enclosed fan cabinet or reach into a unit while the fan is running.

LOCK OPEN AND TAG the fan motor power disconnect switch before working on a fan. Take fuses with you and note removal on tag. Electric shock can cause personal injury or death.

LOCK OPEN AND TAG the electric heat coil power disconnect switch before working on or near heaters.

Failure to follow these warnings could lead to personal injury or death.

### WARNING

CHECK the assembly and component weights to be sure that the rigging equipment can handle them safely.

Note also, the centers of gravity and any specific rigging instructions.

CHECK for adequate ventilation so that fumes will not migrate through ductwork to occupied spaces when welding or cutting inside air-handling unit cabinet or plenum.

WHEN STEAM CLEANING COILS be sure that the area is clear of personnel.

DO NOT attempt to handle access covers and removable panels on outdoor units when winds are strong or gusting until you have sufficient help to control them. Make sure panels are properly secured while repairs are being made to a unit.

DO NOT remove access panel fasteners or open access doors until fan is completely stopped. Pressure developed by a moving fan can cause excessive force against the panel which can injure personnel.

DO NOT work on dampers until their operators are disconnected.

BE SURE that fans are properly grounded before working on them.

Failure to follow these warnings could result in personal injury or equipment damage.

### UNPACKING-CHECK FOR DAMAGE!

**Immediately inspect each unit for damage upon receipt.**

- Inspect units for external and concealed damage immediately.
- File any damage claims in accordance with the Freight Damage Policy and Terms and Conditions.
- Do not repair damaged units without written authorization.
- Protect stored units from damage.

# PRODUCT NOMENCLATURE

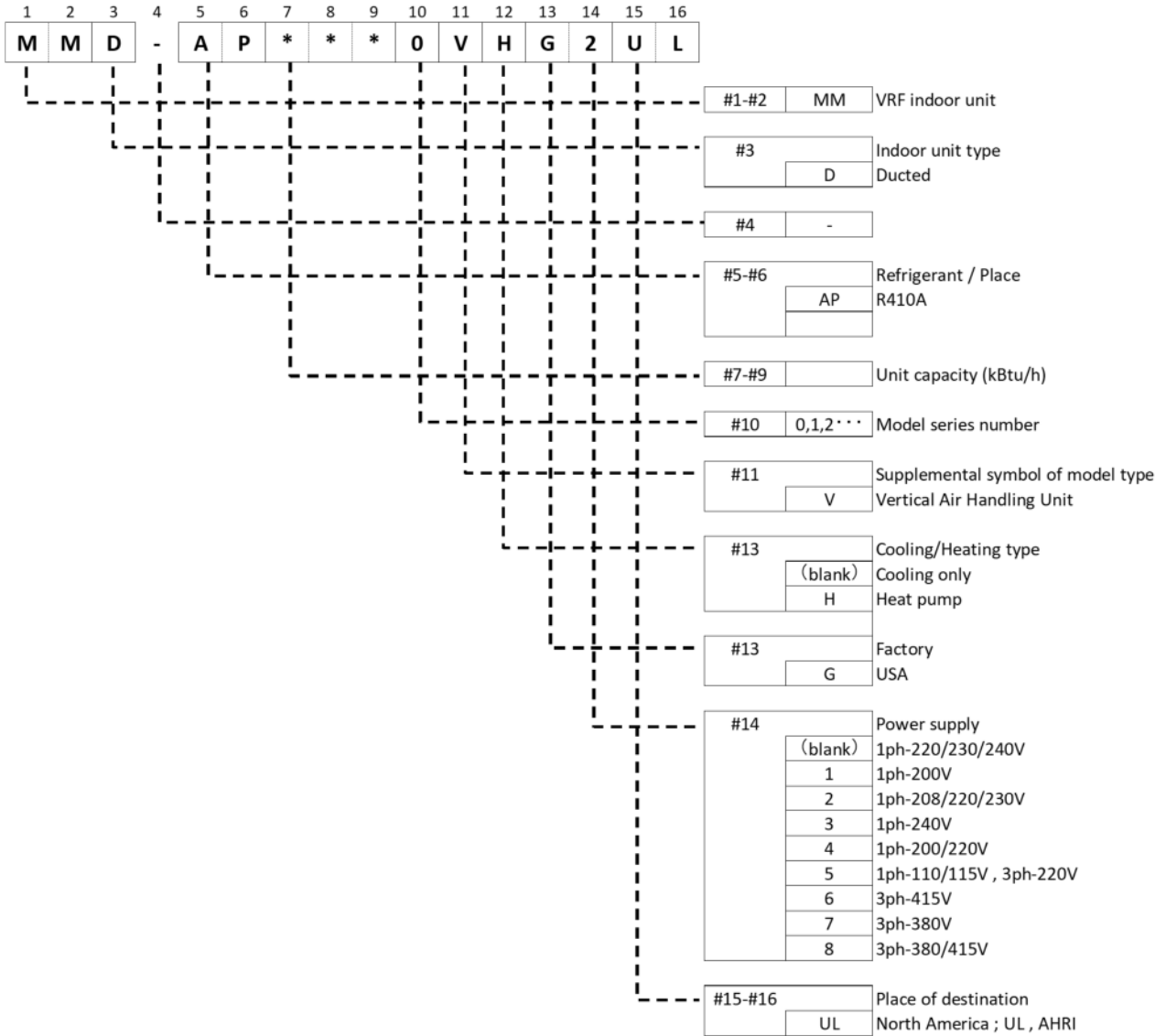

**PRODUCT NOMENCLATURE—ACCESSORIES**

Product name	Product name (Detailed)	Model Name (Final)	Product size (H X W X D)	Packing size (H X W X D)	Weight (lbs, Net)	Weight (lbs, Gross)
Electric Heater	1kW for 12-60k Model	TCB-HT101VDGUL	6.7" X 11.0" X 22.5"	9" X 13" X 27"	4.0	6.0
Electric Heater	3kW for 12-60k Model	TCB-HT301VDGUL	6.7" X 11.0" X 22.5"	9" X 13" X 27"	5.0	7.0
Electric Heater	5kW for 12-60k Model	TCB-HT501VDGUL	6.7" X 11.0" X 22.5"	9" X 13" X 27"	5.0	7.0
Electric Heater	6kW for 18-60k Model	TCB-HT601VDGUL	6.7" X 11.0" X 22.5"	9" X 13" X 27"	5.0	8.0
Electric Heater	8kW for 30-60k Model	TCB-HT801VDGUL	6.7" X 11.0" X 22.5"	9" X 13" X 27"	6.0	8.0
Electric Heater	9.5kW for 30-60k Model	TCB-HT951VDGUL	6.7" X 11.0" X 22.5"	9" X 13" X 27"	6.0	8.0
Plenum Chamber	For 12-24k Model, with 2" Filter, Single Pkg	TCB-PL2S241VDGUL	20.2" X 17.5" X 22.2"	22" X 23" X 28"	36.0	43.0
Plenum Chamber	For 30-36k Model, with 2" Filter, Single Pkg	TCB-PL2S361VDGUL	20.2" X 20.0" X 25.2"	22" X 26" X 31"	41.0	49.0
Plenum Chamber	For 42-48k Model, with 2" Filter, Single Pkg	TCB-PL2S481VDGUL	24.2" X 22.0" X 27.2"	26" X 28" X 33"	49.0	59.0
Plenum Chamber	For 60k Model, with 2" Filter, Single Pkg	TCB-PL2S601VDGUL	24.2" X 24.0" X 31.2"	26" X 30" X 37"	60.0	71.0
Filter Box	For 12-24k Model, 2" MERV 8 Filter	TCB-FB2F241VDGUL	4" X 17.5" X 22.2"	8" X 21" X 26"	12.0	15.0
Filter Box	For 30-36k Model, 2" MERV 8 Filter	TCB-FB2F361VDGUL	4" X 20.0" X 25.2"	8" X 23" X 29"	14.0	18.0
Filter Box	For 42-48k Model, 2" MERV 8 Filter	TCB-FB2F481VDGUL	4" X 22.0" X 27.2"	8" X 25" X 31"	15.0	19.0
Filter Box	For 60k Model, 2" MERV 8 Filter	TCB-FB2F601VDGUL	4" X 24.0" X 31.2"	8" X 27" X 35"	20.0	25.0

**Notes:**

1. Plenums have 1/2" fiberglass insulation.
2. Plenums and filter boxes have filter slot that will accept 4" thick filter or 2" thick filter. To use with 4" thick filter filter, remove 2" filter, remove filter rail, and add field-supplied 4" thick filter.
3. Return air Grille(s) and duct collars are field-provided and field-installed.
4. Plenums have return air duct openings on front, right and left sides. **Front** and **right** sides have flat covers that can be relocated as needed. Opening in rear can be cut in the field.

## INSTALLATION

### Pre-installation

1. Check items received against packing list.
2. Do not stack unit components or accessories during storage. Stacking can cause damage or deformation.
3. If unit is to be stored for more than 2 weeks prior to installation, observe the following precautions:
  - a. Choose a dry storage site that is reasonably level and sturdy to prevent undue stress or permanent damage to the unit structure or components. Do not store unit on vibrating surface. Damage to stationary bearings can occur. Set unit off ground if in heavy rain area.
  - b. Remove all fasteners and other small parts from jobsite to minimize theft. Tag and store parts in a safe place until needed.
  - c. Cover entire unit with a tarp or plastic coverall. Extend cover under unit if stored on ground. Secure cover with adequate tie-downs or store indoors. Be sure all coil connections have protective shipping caps.
  - d. Monthly — Remove tarp from unit, enter fan section through access door or through fan inlet, and rotate fan and motor slowly by hand to redistribute the bearing grease and to prevent bearing corrosion.

**Rigging** — Do not remove shipping skids or protective covering until unit is ready for final placement. Use slings and spreader bars as applicable to lift unit. *Do not lift unit by coil connections or headers.*

Do not remove protective caps from coil piping connections until ready to connect piping.

### Unpacking

1. Remove all packaging and any foreign material from unit.
2. Check blower wheel for free rotation.
3. Check copper lines, coil etc. for internal or hidden damage.

### Return Air and Unit Orientation

Units may be positioned in several configurations depending on the return air configuration selected—see Figure 1.

**NOTE:** Right and left return units are not recommended for horizontal installation.

### Service Clearance

The fan coil is completely serviceable from the front. Units are approved for 0" (zero inches) of clearance. This allows substantial freedom in the positioning of the unit to best serve the requirements of the structure.

### WARNING-AUXILIARY DRAIN PAN RECOMMENDED:

This product has an auxiliary condensate drain which should be piped to a condensate overflow sensor or safe drain location or both to protect the equipment and property from damage in the case of condensate overflow.

In addition, the International Mechanical Code (IMC) section 307.2.3 requires the use of auxiliary drain pans. Many municipalities have adopted this code.

This practice represents the standard for professional installation whether or not this code has been adopted in a specific municipality or territory. As such, water damages that would have been prevented had an auxiliary pan been deployed will not be considered for compensation. This position is taken regardless of whether the source of the moisture was specified as a potential failure mode in the applicable building code or not. A freeze burst, cracked drain pan, failed weld, or corrosion induced leak are some of the potential failure modes that are mitigated when an auxiliary pan is properly installed. Professional installers recognize the value of protecting customer assets against foreseeable events. Customers who choose to avoid the cost of common protective measures waive their right to seek damages when those foreseeable events occur. If the product is located above a living space or where damage may result from condensate overflow, install a watertight pan of corrosion-resistant metal beneath the unit to catch over-flow which may result from clogged drains or from other reasons. Provide proper drain piping for this auxiliary pan. Consult local codes for additional precautions before installation.

### Unit Support

**Floor mounting:** Unit may be mounted on a housekeeping pad, floor, platform or plenum. Provide a suitable isolation pad to minimize sound transmission to the structure. **CAUTION! Make sure to allow enough elevation to permit construction of the condensate trap. Also allow enough elevation and clearance for opening the filter door (removes to the front).** See Service Clearances.

Install the unit so that it is level or pitches slightly  $-(1/8$  inch) — toward the condensate drain connection.

Anchor the unit to the plenum or platform through the bottom flange using 2ea #10 sheet metal screws on each side (4 screws total).



# INSTALLATION

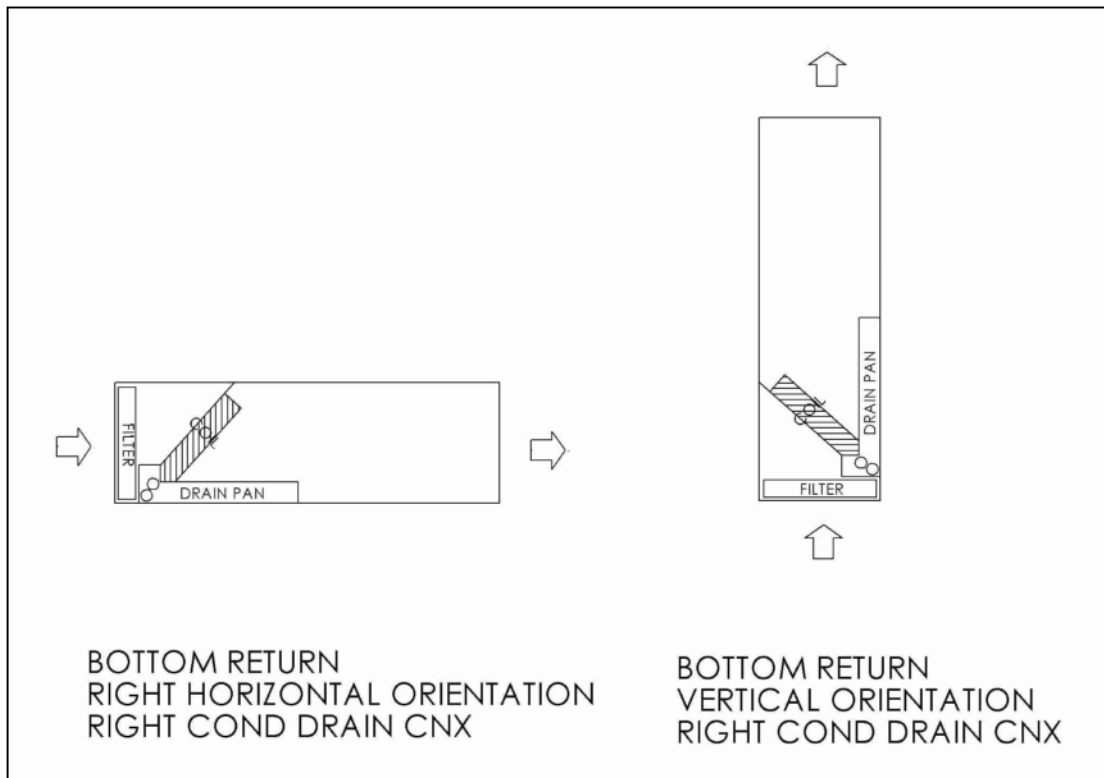

**Figure 1**  
**Return Configurations and**  
**Unit Orientations**

# INSTALLATION—SERVICE CLEARANCES

UNIT SIZE	CLEARANCE DIMENSION (INCHES)					
	A	B	C	D	E	F
12/18/24	36.0	36.0	36.0	22.0	6.0	9.0
30/36	36.0	36.0	36.0	25.0	6.0	10.0
42/48	36.0	36.0	36.0	27.0	6.0	11.0
60	36.0	36.0	36.0	31.0	6.0	11.0
	G	H	L	M	N	
12/18/24	12.0	7.0	19.4	35.7	45.0	
30/36	12.0	7.0	23.5	40.6	50.0	
42/48	12.0	7.0	26.3	43.6	54.0	
60	12.0	7.0	28.3	46.4	56.0	

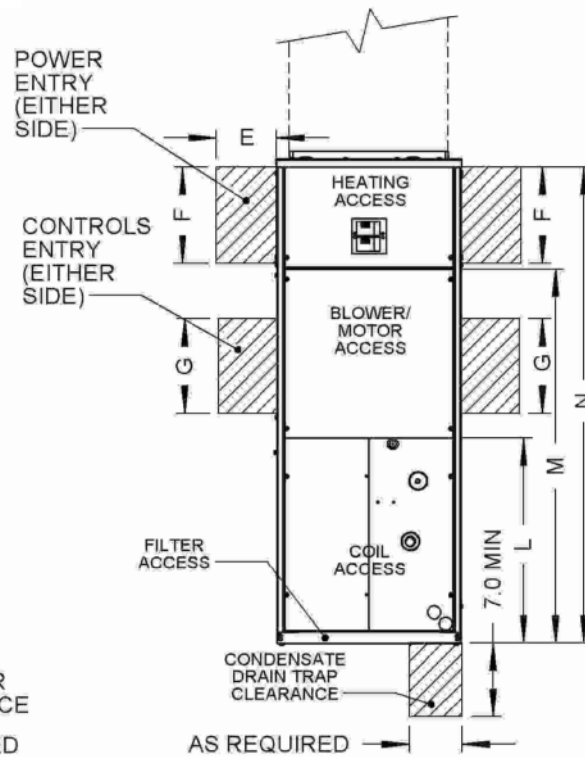
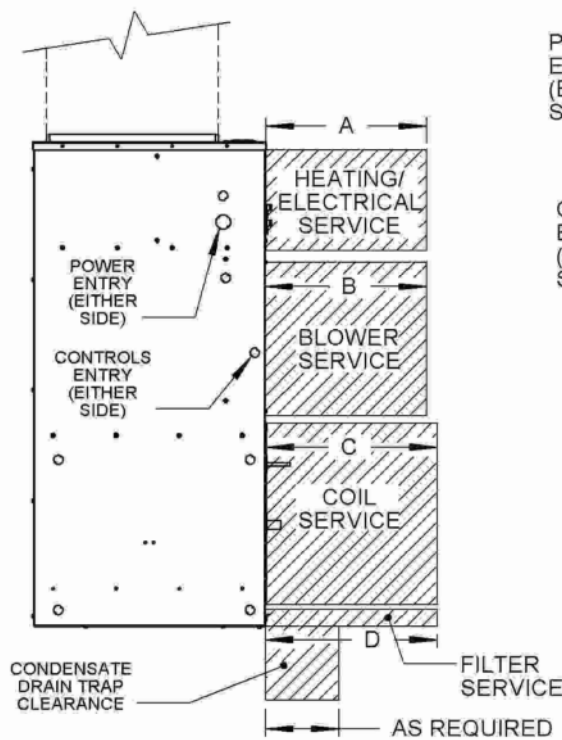
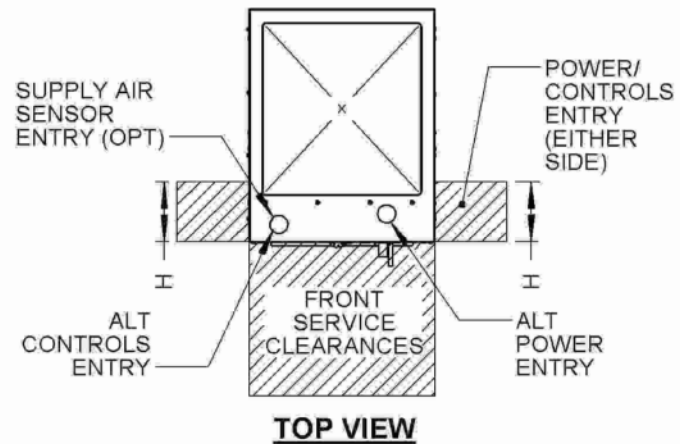

**NOTES:**

1. BLOWER SERVICE REQUIRES FRONT ACCESS ONLY.
2. RECOMMENDED BUT NOT NECESSARY: ALLOW 12" ON RIGHT AND LEFT SIDES FOR SIGNIFICANT BUT INFREQUENT SERVICE PROCEDURES SUCH AS DRAIN PAN OR COIL REPLACEMENT.
3. WHEN UNIT IS INSTALLED HORIZONTALLY (LYING ON RIGHT SIDE), CLEARANCES REMAIN THE SAME AS INDICATED ABOVE, EXCEPT TRAP CLEARANCE EXTENDS BELOW THE UNIT.

## INSTALLATION

**Ceiling Suspension:** Mount the unit in ceiling-suspended horizontal orientation per suspension details (Figure 4a). Unit is NOT intended to be wall mounted. Consult a qualified structural engineer for special mounting considerations.

Install the unit so that it pitches slightly  $-(1/8$  inch) – toward the condensate drain connection.

### Condensate Drain

Install a trapped condensate drain line at unit drain connection. All MMD units have 3/4 in. FPT condensate main and auxiliary drain

#### WARNING

**INSURE THAT THE UNIT IS ADEQUATELY SUPPORTED FROM STRUCTURE TO PREVENT DAMAGE OR INJURY CAUSED BY FALLING EQUIPMENT! If uncertain about how to connect to the structure, consult a qualified structural engineer.**

connections.

Provide adequate trap clearance (trap depth) beneath the unit as indicated in Fig. 3. Provide freeze-up protection as required to insure reliable condensate drainage. Freeze protection measures are customer-supplied and installed.

Pipe to condensate drain using PVC or copper or other suitable material. Pitch drain piping downward at a minimum slope of 1/8 inch per foot.

Pipe auxiliary drain to “tell tale” drain location or floor drain to clearly indicate when condensate drain service is required. Alternately, use a field-provided condensate overflow detection device in the auxiliary drain connection to provide alarm or other controls action when the drain pan fills to the level of the auxiliary drain.

### Placing Unit In Ductwork

1. Utilize flexible transitions on supply and return connections to reduce noise and vibration transmission to the structure.
2. When the connecting return air duct is smaller than the coil inlet opening, construct the transition piece so that the vertical and horizontal dimensions of the transition piece do not increase more than one inch for every seven inches of length of the transition piece.
3. Provide at least three feet of straight duct work preceding the unit inlet.

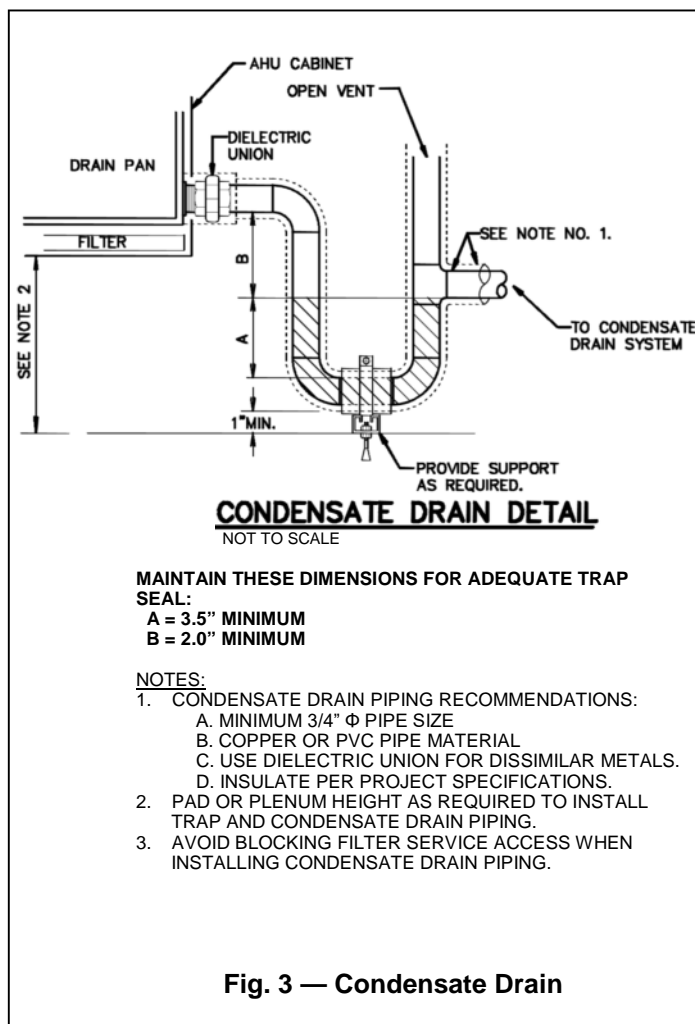

**Fig. 3 — Condensate Drain**

### Duct Insulation and Vapor Proofing:

Properly select and install duct insulation as required by the application.

All externally insulated duct work must have an adequate vapor seal for summer operation. This is particularly important where the duct is exposed to highly humid conditions in such places as attics, vented crawl spaces, unconditioned basements, and utility rooms. The vapor seal prevents condensation of moisture in the insulating material and subsequent loss of its insulating value.

ITEM NO.	DESCRIPTION	QTY.
1	MMD AIR HANDLER	1
2	UNISTRUT, 1-5/8 X 1-5/8, 16 GA MIN, 9/16" DIA HOLES OR EQUIV	2
3	ALL THREAD 3/8" NOM, ASTM A307-GR A OR EQUIV	4
4	FLAT WASHER USS, 3/8" NOM, ANSI B18.22.1	8
5	LOCK WASHER, 3/8" NOM, ANSI B18.21.1	8
6	HEX NUT, 3/8"-16 UNC, ASTM A563-GR A OR EQUIV	8
7	GASKET TAPE, RUBBER OR EQUIV	2

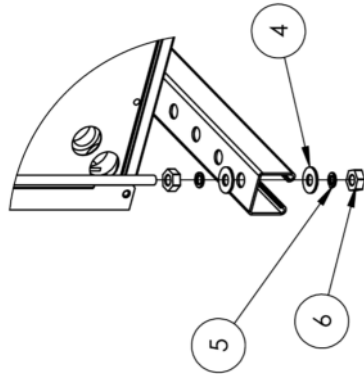

DETAIL A

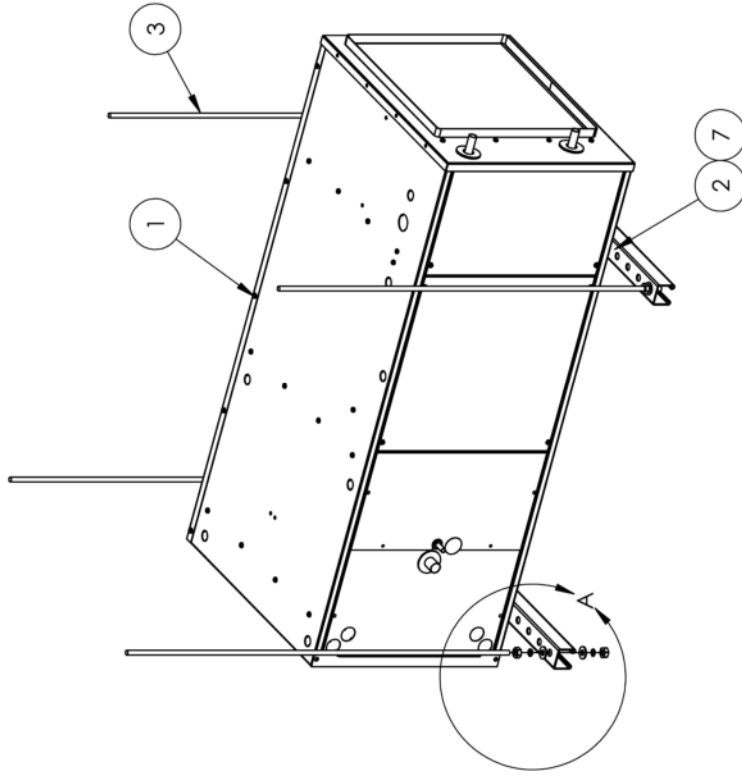
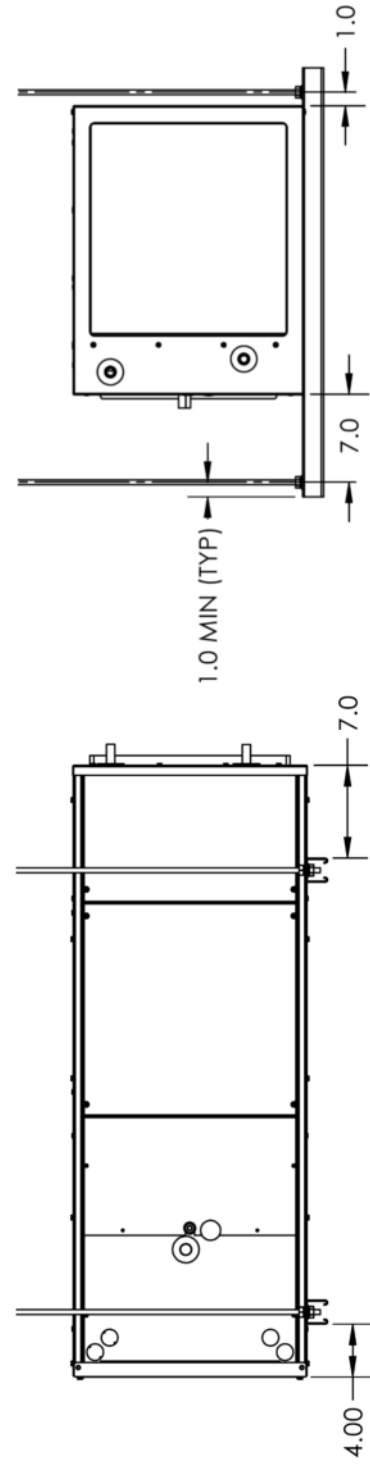

Figure 4a  
CEILING SUSPENSION DETAILS



## INSTALLATION

### CAUTION

Direct-expansion coils are shipped pressurized with dry nitrogen. Release pressure from the coil through valves in protective caps before removing caps.

Do not leave piping open to the atmosphere unnecessarily. Water and water vapor are detrimental to the refrigerant system. Until the piping is complete, recap the system and charge with nitrogen at the end of each workday. Clean all piping connections before soldering joints.

Failure to follow these procedures could result in personal injury or equipment damage.

### Refrigerant Piping

Refrigerant coils have liquid and suction line connections through the front of the cabinet. **CAUTION:** Use proper care when brazing including use of heat sink (wet cloth or other method) to prevent damage to liquid line and suction line components (see Figure 4b)

Size and install refrigerant lines in accordance with the condensing unit manufacturer's instructions. Provide insulation on the suction line, to prevent condensation. Provide insulation on the liquid line if unit to be used for heat pump service or if otherwise required.

### System Design Regulation

When connecting MMD units in the VRF system (mix or all), **keep indoor/outdoor unit capacity ratio with the range of 50% to 135%.** For other conditions, refer to the VRF System standard piping design regulations.

Connecting pipe size is shown in the following table.  
**NOTE:** Be sure to use the reducer pipe (shipped loose with the air handler) so as to match the connecting pipe size for unit sizes 012 and 018.

Unit Size	Indoor connecting pipe		Reducer pipe 	
	Gas side	Liquid side	Gas side	Liquid side
012	3/8"	1/4"	5/8" to 3/8"	3/8" to 1/4"
018	1/2"	1/4"	5/8" to 1/2"	3/8" to 1/4"
024	5/8"	3/8"	Unnecessary	Unnecessary
030				
036				
042				
048				
060				

Wrap AHU-side piping with wet cloth before brazing.

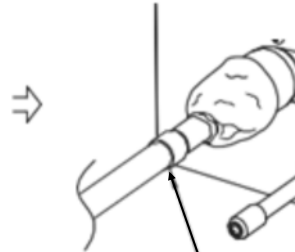
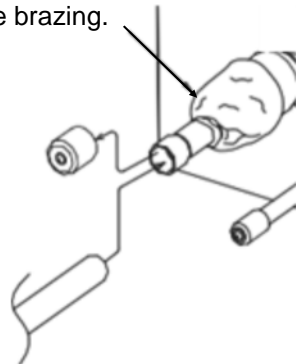

Apply brazing to full circumference

**Fig. 4b — Connection of Refrigerant Piping—Brazing Details**

## INSTALLATION—ELECTRIC HEAT

### Electric Heater Accessory

The electric heater may be factory-installed or field-installed. See Figures 5 through 8.

#### Removal Procedure:

To remove the electric heater,

1. Disconnect and lock out electrical power from the unit. Remove heater access panel. Disconnect power wires from the power switch—**DANGER!** - MAKE SURE there is no voltage on these wires before disconnecting!
2. Disconnect 2 harness connectors at the blower deck.
3. Remove 2 screws holding heater support feet to the blower deck.
4. Remove 4 screws that mount the heater to the heater bulkhead. Handle heater carefully to avoid damaging the wire heating elements. Remove heater from the unit.

### DANGER

**WARNING: Hazardous voltage.** Only qualified personnel must install the electrical service. Disconnect and Lock Out all incoming power sources before connecting to electrical service.

**WARNING:** This appliance must be permanently grounded in accordance with the National Electrical Code and local code requirements.

**WARNING:** For use with copper conductors only.

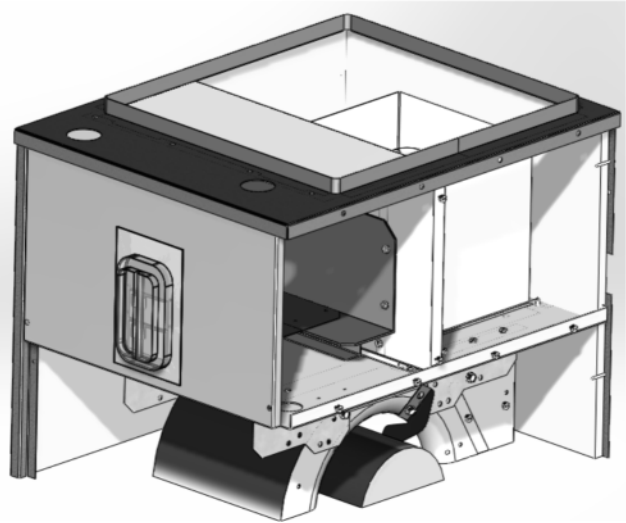

**Fig. 5 — Heater Accessory Installed  
(right side panel not shown)**

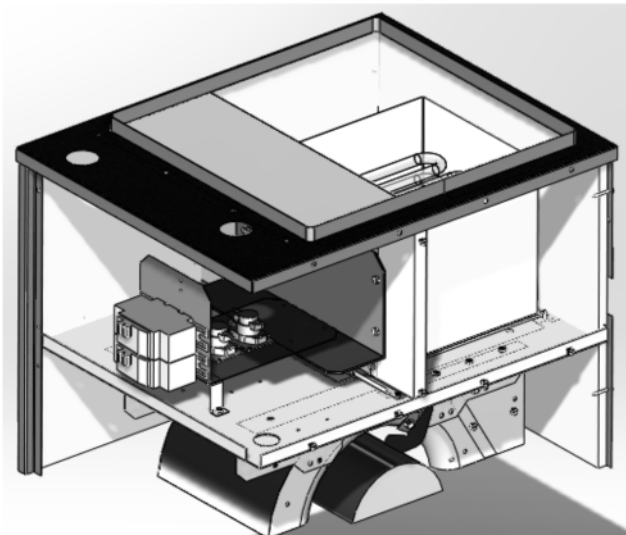

**Fig. 6 — Heater Accessory Installed  
(right side and heater access panels  
not shown)**

## INSTALLATION—ELECTRIC HEAT

### Electric Heater Accessory-MMD size 12, 18 and 24

The electric heater must be adjusted to fit unit sizes 1-ton, 1.5-ton and 2-ton unit models (MMD-AP0120, MMD-AP0180, MMD-AP0240). See Figures 6b through 6e.

#### Switch Plate Adjustment Procedure:

To adjust the switch plate to shorten the heater length, remove the two mounting screws that attach the switch plate to the heater plate. Screws install from the bottom.

Next, slide the switch plate toward the heater plate, line up the two holes, and re-install the two screws. The final assembly is shorter to match the shallower depth of the 1/1.5/2.0 ton size cabinets.

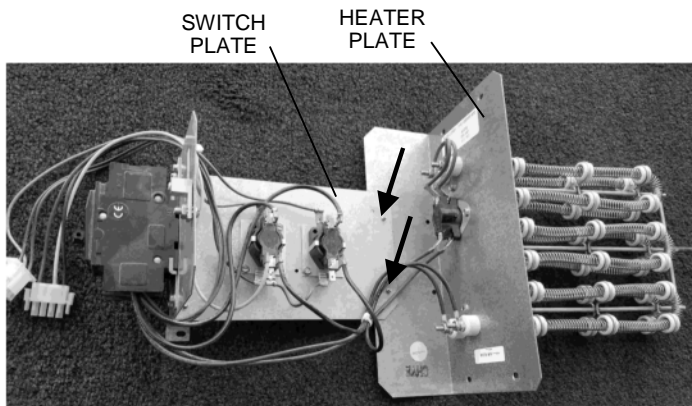

**Fig. 6b — Heater—Long Format**  
(mounting screws shown by arrows)

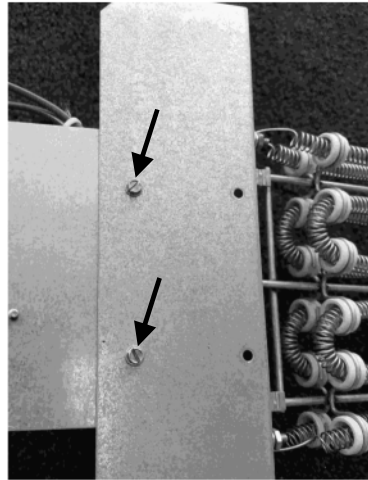

**Fig. 6c  
Heater—Long  
Format**  
(Bottom view;  
mounting  
screws shown  
by arrows)

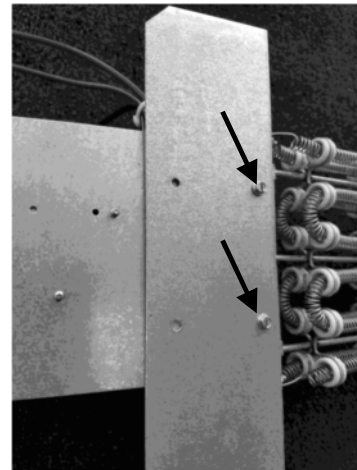

**Fig. 6d  
Heater—Short  
Format**  
(Bottom view;  
mounting  
screws shown  
by arrows)

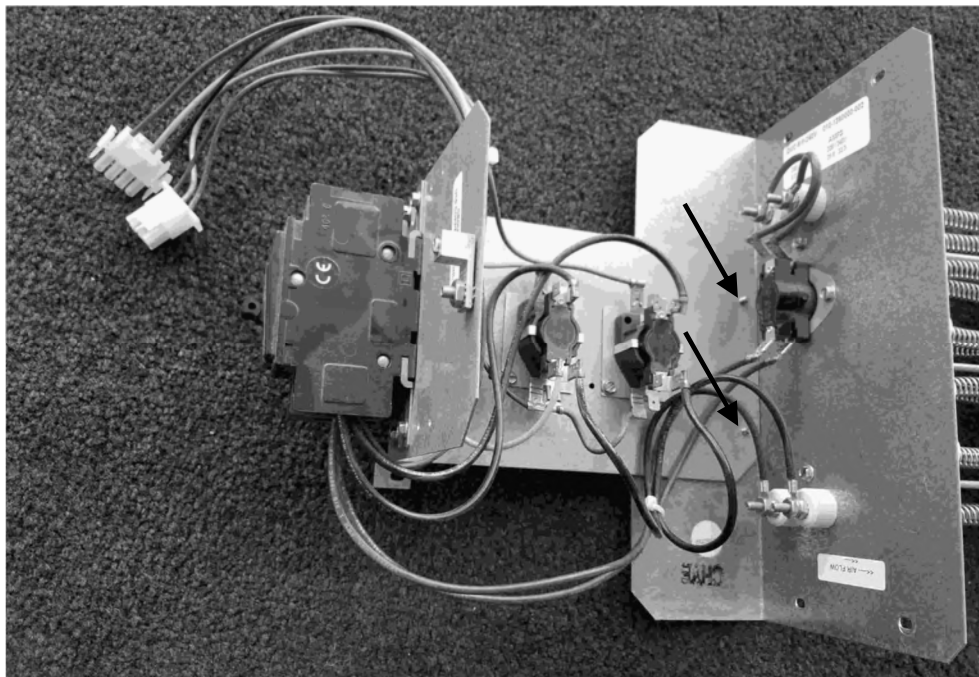

**Fig. 6e  
Heater—Short  
Format**  
(mounting  
screws shown  
by arrows)

**DANGER**  
**WARNING: Hazardous voltage.** Only qualified personnel must install the electrical service. Disconnect and Lock Out all incoming power sources before connecting to electrical service.

## INSTALLATION-ELECTRIC HEAT

### Install Procedure:

To install the electric heater,

1. Disconnect and lock out electrical power from the unit. Remove heater access panel. Disconnect field power wires from the unit power wires. **DANGER! - MAKE SURE there is no voltage supply to the unit before proceeding!**
2. Disconnect and discard 1 harness connector at the blower deck.
3. Remove blank plate from heater access panel (covers square hole for breaker style power switches).
4. Remove SAT sensor and sensor holder from heater bulkhead and reposition on unit discharge ductwork routing through auxiliary SAT sensor hole on top panel.
5. Install SAT 3 feet after the first 90 degree turn in the discharge ductwork.
6. Remove plate on the heater bulkhead (4 screws).
7. Install heater by carefully supporting the heater and inserting it into the opening in the heater bulkhead. **NOTE:** Make sure to guide the pin into the hole at the back of the heater shroud. Secure the heater to the bulkhead with 4 screws.
8. Connect 2 wiring harnesses (male) to the matching female receptacles in the blower deck.
9. Connect field wiring to the breaker-style power

## DANGER

**WARNING: Hazardous voltage.** Only qualified personnel must install the electrical service. Disconnect and Lock Out all incoming power sources before connecting to electrical service.

switches on the front of the heater. **WARNING! Be sure to provide the appropriate wire size and branch circuit protection as required by the unit nameplate!**

10. Install the heater access panel.
11. Install the silicone cover "boot" over the top of the power switches. This protects them from dust buildup. The switches may be activated through the flexible boot material.
12. Mark the nameplate label with the matching heater kW rating. Label is located on the exterior of the front top panel.

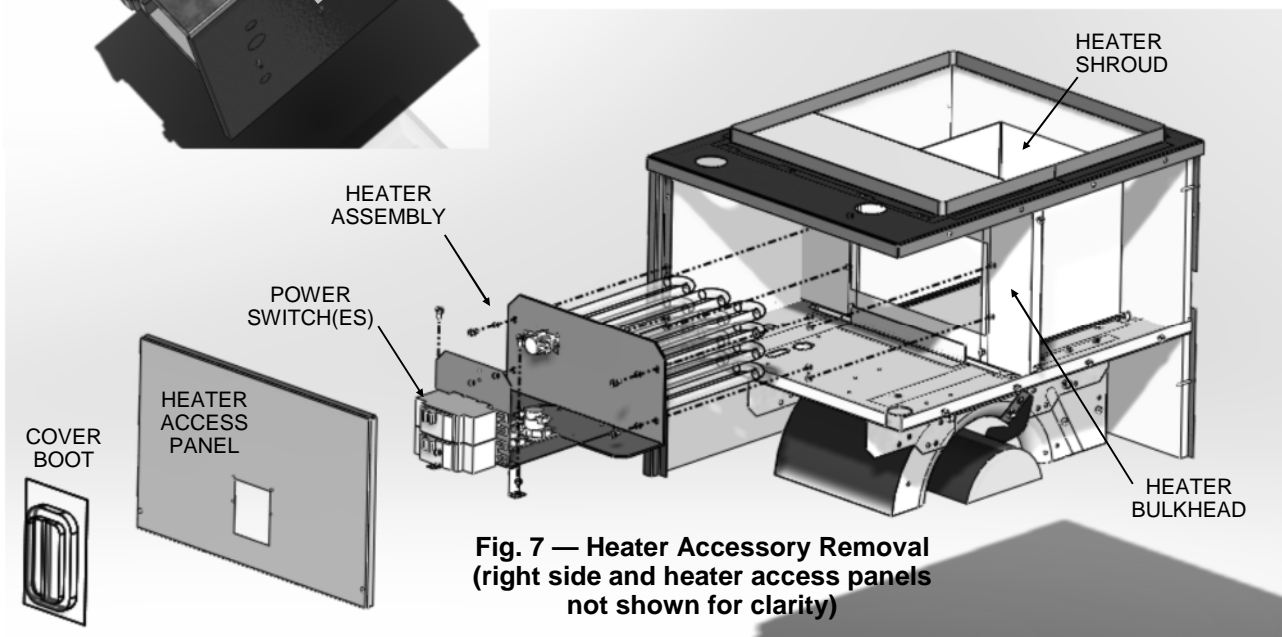
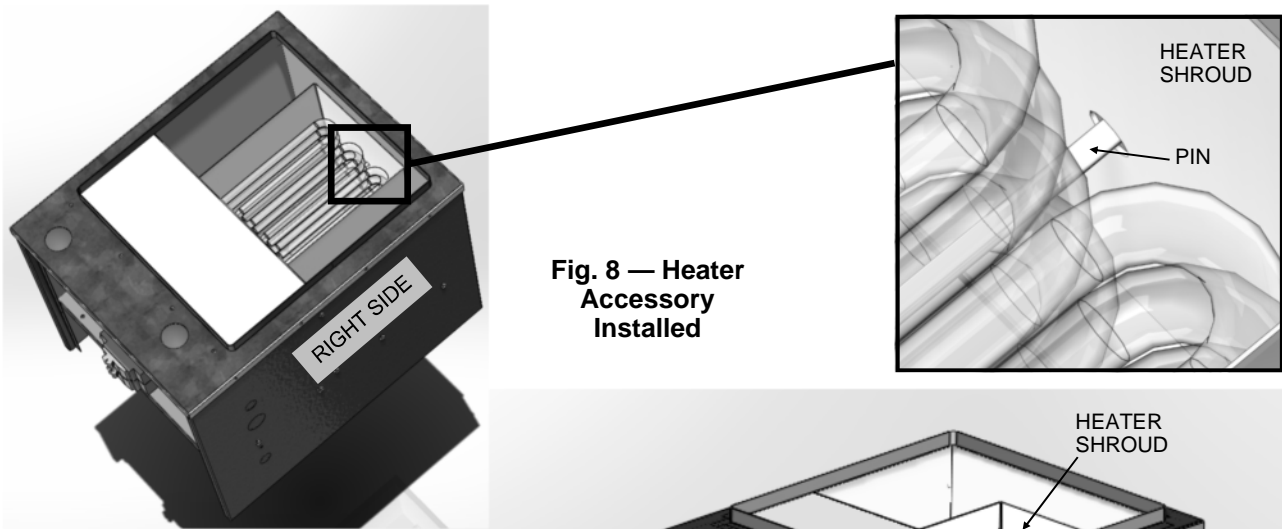



## INSTALLATION-ELECTRICAL

### DANGER

**WARNING: Hazardous voltage.** Only qualified personnel must install the electrical service. Disconnect and Lock Out all incoming power sources before connecting to electrical service.

**WARNING:** This appliance must be permanently grounded in accordance with the National Electrical Code and local code requirements.

**WARNING:** For use with copper conductors only.

Typical wiring diagrams are shown on the following pages FOR REFERENCE. Always refer to the wiring diagram on the air handling unit for actual wiring.

### NOTE: CHECK MOTOR RATING PLATE FOR CORRECT LINE VOLTAGE.

Connect electrical service to unit. Refer to unit wiring diagram.

### Power Wiring

For power supply connection, route field power wiring L1 and L2 and connect either:

1. Unit Without EH: to field-provided and installed disconnect switch and from switch to power entry (unit side) and to unit power leads inside the unit electrical section; or
2. Unit With EH: into the unit through power entry (unit side) and then to the factory installed power switch inside the electrical section (see Figure 9). Note: power switch looks like a circuit breaker but **does not provide overload protection**. Power switch provided only with electric heater (field kit or factory installed). NOTE: When electric heat greater than 10kW is provided, two power supply circuits are required, as shown on the wiring diagram.

Refer to nameplate or Electrical Ratings (page 28) for FLA, maximum overcurrent protection device (MOPD) and minimum circuit ampacity (MCA). Also refer to wiring diagram affixed to unit to make control and power wiring connections. For new heater installation, mark the nameplate label with the matching heater kW rating. Label is located on the exterior of the front top panel.

**NOTE:** Installer is responsible for power wiring and branch circuit over current protection.

### Control Voltage Wiring

Control voltage wiring may enter the unit at the control box located behind the blower access door, or other convenient location. Control voltage wiring

### DANGER

NEVER enter an enclosed fan cabinet or reach into a unit while the fan is running.  
LOCK OPEN AND TAG the fan motor power disconnect switch before working on a fan. Take fuses with you and note removal on tag. Electric shock can cause personal injury or death.  
LOCK OPEN AND TAG the electric heat coil power disconnect switch before working on or near heaters.  
Failure to follow these warnings could lead to personal injury or death.

### CAUTION

Use only copper conductors for field-installed electrical wiring. Unit terminals are not designed to accept other types of conductors.

Do not allow wiring to touch the refrigerant tubing, compressor, or any moving parts of the fan.

Make wiring connections in accordance with the system wiring system diagram and these instructions. Wrong wiring may cause improper operation or unit damage!

Unauthorized changes in the internal wiring can be very dangerous. The manufacturer will accept no responsibility for any damage or malfunction that occurs as a result of such unauthorized changes.

leads exit the bottom of the control box and are ready for field-connection.

**CAUTION!** To prevent malfunction of the air conditioner caused by electrical noise, route control wiring and inter-unit control wiring SEPARATELY FROM THE POWER WIRING!

### General

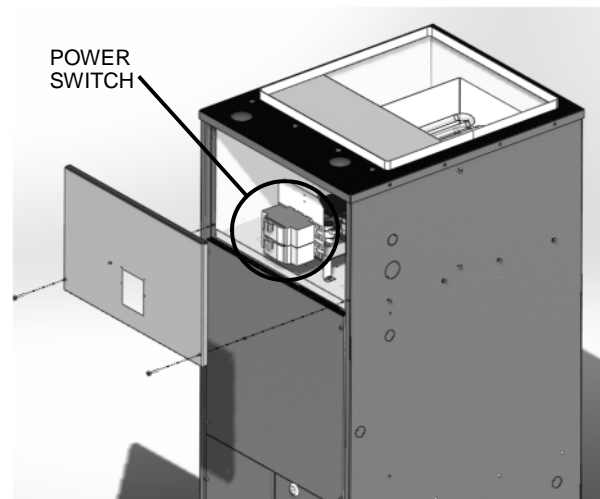

**Figure 9**  
**Unit with Electric Heat**

**INSTALLATION-ELECTRICAL**

Provide strain relief where field wiring passes through cabinet. Wiring within the cabinet has been positively located and supported so that it does not pass over sharp metal edges or come in contact with moving parts. After servicing, position wiring properly in the original supports.

All field-installed wiring, including the electrical ground, MUST comply with the National Electrical Code (NEC) as well as applicable local codes. In addition, all field wiring must conform to the Class II temperature limitations described in the NEC.

Refer to factory wiring diagrams installed in the unit. Use the MCA and MOPD from the nameplate or electric heat nameplate or Electrical Ratings (page 30) to size power supply wiring and overcurrent protection device. Installation must comply with NEC and local codes.

For communicating controls, refer to electrical specific instructions, page 33-41. Refer to the condensing unit operation manual for more details.

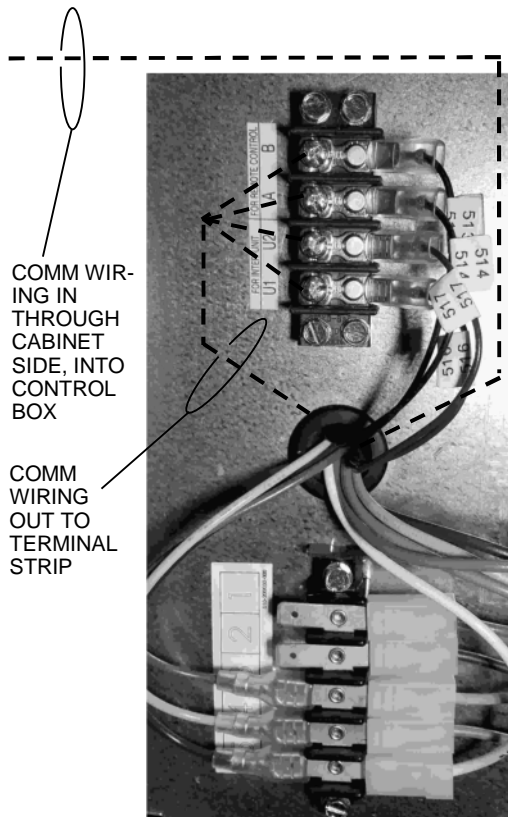

**Figure 9c**  
**Communications Wiring**

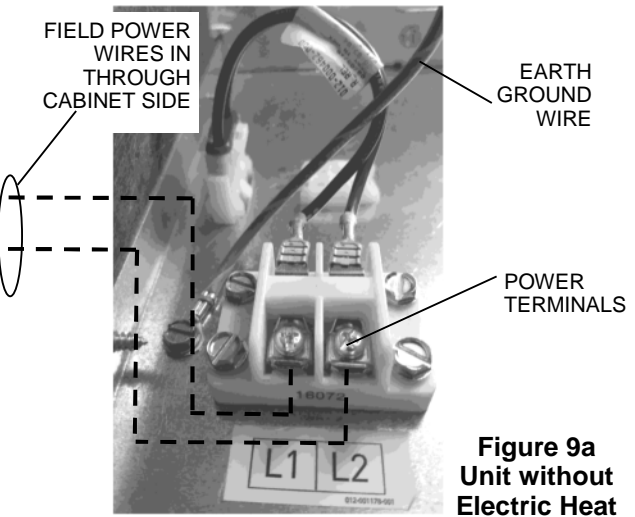

**Figure 9a**  
**Unit without Electric Heat**

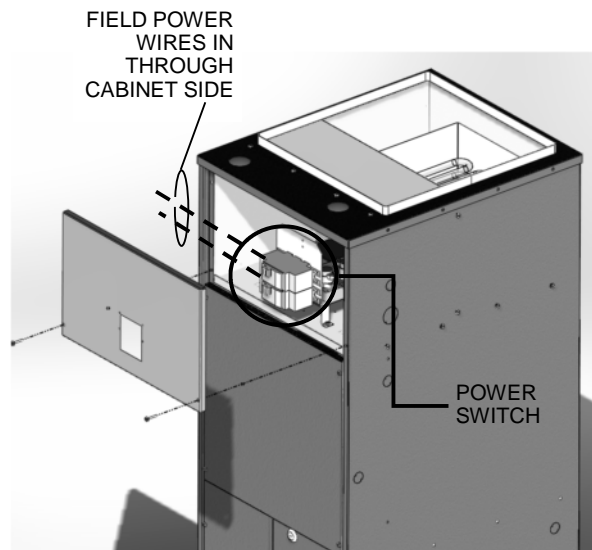

**Figure 9b**  
**Unit with Electric Heat**

**DANGER**

**WARNING: Hazardous voltage.** Only qualified personnel must install the electrical service. Disconnect and Lock Out all incoming power sources before connecting to electrical service.

**WARNING:** This appliance must be permanently grounded in accordance with the National Electrical Code and local code requirements.

**WARNING:** For use with copper conductors only.

**CAUTION**

Loose wiring may cause the terminal to overheat or result in unit malfunction or cause a fire hazard. Insure that all wiring is tightly connected!

INSTALLATION-ELECTRICAL (cont'd)

TYPICAL WIRING DIAGRAM

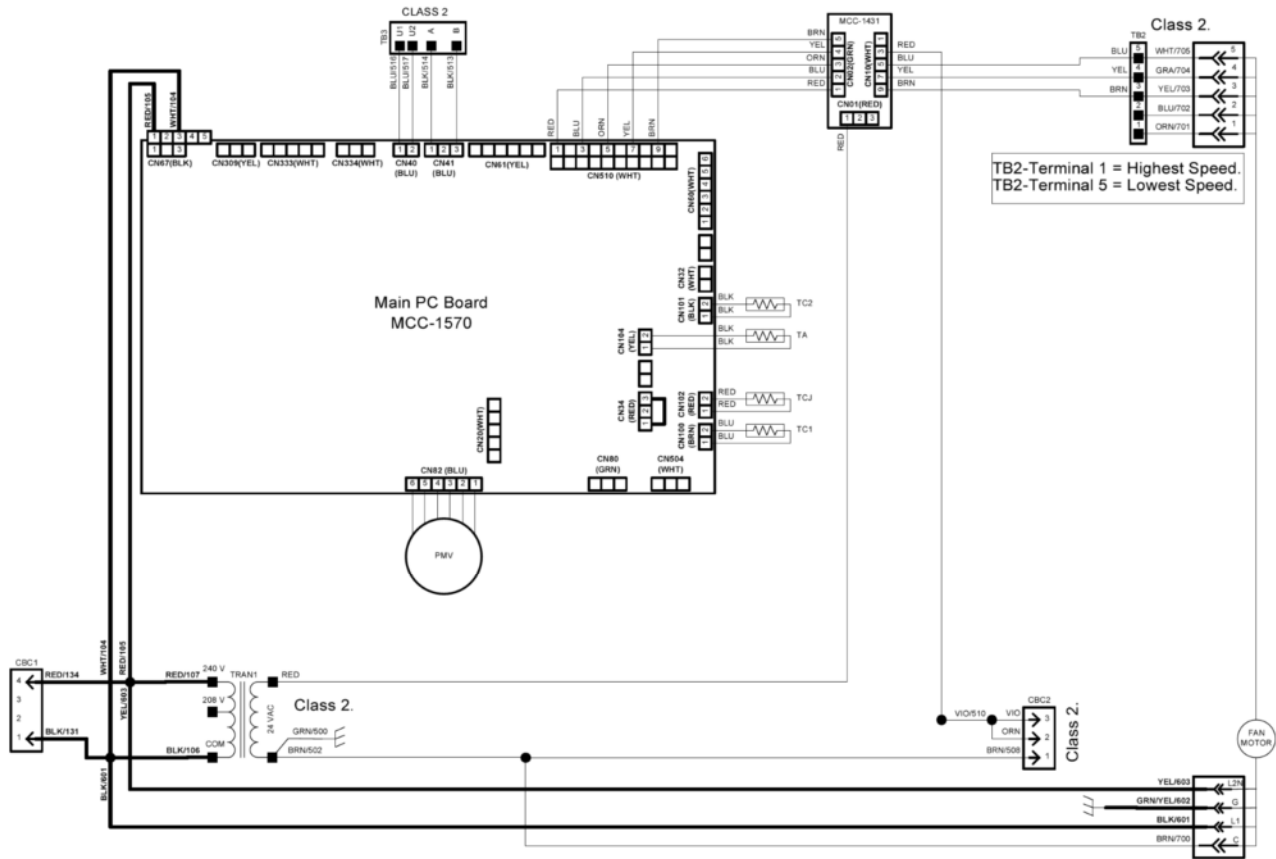

TB2-Terminal 1 = Highest Speed.  
 TB2-Terminal 5 = Lowest Speed.

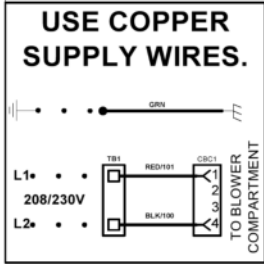

>>	HARNESS CONNECTION
●	SPLICE
■	CONNECTION POINT
X	INSULATED WIRE
—	FACTORY WIRING
- - -	OPTIONAL WIRING
● ●	WIRES BY OTHERS
⊥	CHASSIS GROUND
⊥	EARTH GROUND
TRAN	TRANSFORMER
TB	TERMINAL BLOCK

INSTALLATION-ELECTRICAL (cont'd)

TYPICAL WIRING DIAGRAMS—  
Electric Heat: 1-6kW and 8-9.5kW

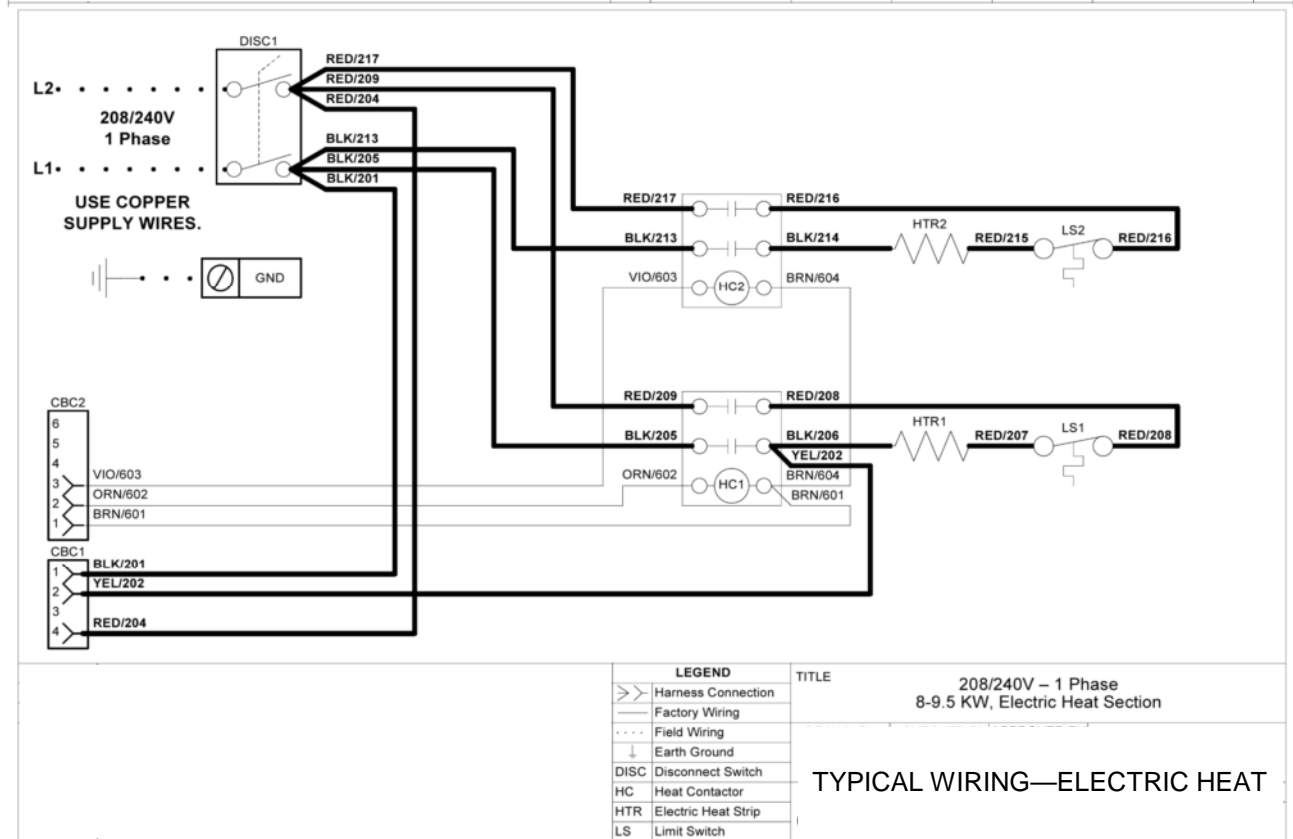
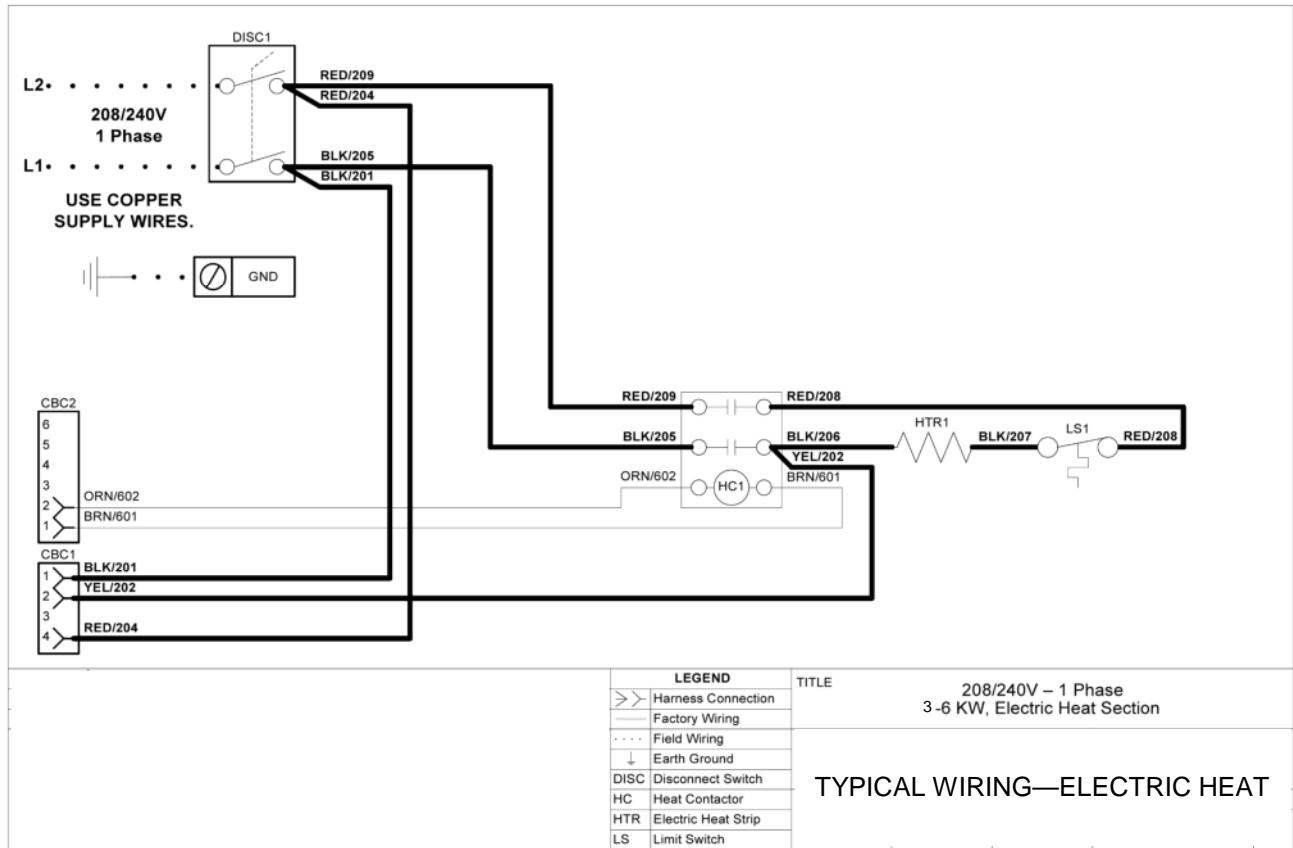

## START-UP

### Pre-Startup

**Building Envelope**—All building windows and doors should be installed and closed before starting unit. During summer construction, avoid unit sweating by allowing for gradual pull down: use reduced capacity and use maximum available airflow.

**Temperature Controls**—Check that unit is connected to the controls system and communicating properly.

### Outside Air and Freeze Protection

**WARNING: Insure that the property is protected against freezing conditions. Failure to provide freeze protection may result in property damage.** Freeze protection measures are customer-provided and installed and include but are not limited to low-limit thermostats, automatic temperature controls, and outside air dampers.

### Startup

1. Insure electrical installation agrees with the unit nameplate (voltage, branch circuit protection, wire size).
2. Close all panels and access doors. Make sure filter media is clean before starting unit. Replace filter if necessary.
3. Verify that discharge ductwork and input plenum are in place and secure.
4. Apply power to unit. If unit is equipped with on-board power switch(es), turn switch(es) to the “On” position.
5. Insure that controls system has power and is operational.
6. Force control system to send fan on signal and speed signal. Refer to unit wiring diagram and electrical section for fan speed control arrangement.
7. Fan should start and run. Make sure fan operates without significant noise or vibration.
8. Allow control system to start condensing unit, or as required for the installation.
9. Complete the checklist on the Start-Up Report.
10. Follow additional startup procedures for the system as required by the condensing unit.

### Fan Airflow Step-Up

If the duct system ESP is higher than planned and increased Air Handler ESP is needed, shift the terminals as shown in Figure 15 images.

Refer to the curves for airflow performance (pages 26-27).

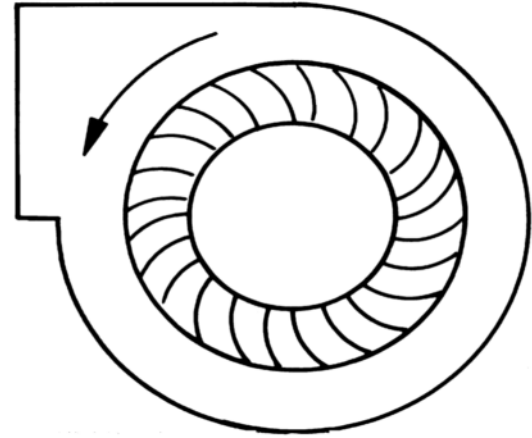

FORWARD CURVED

Fig. 14 — Fan Wheel Rotation—  
FORWARD CURVED FAN

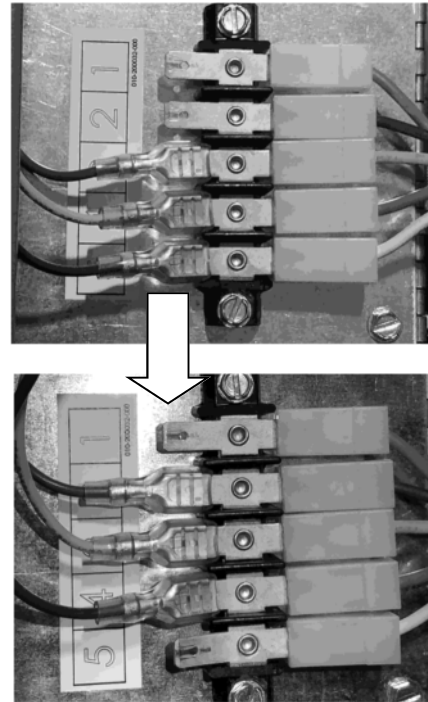

Fig. 15 — Fan Terminal Settings—  
ESP Adjustment

## DANGER

NEVER enter an enclosed fan cabinet or reach into a unit while the fan is running.  
LOCK OPEN AND TAG the fan motor power disconnect switch before working on a fan. Take fuses with you and note removal on tag. Electric shock can cause personal injury or death.  
LOCK OPEN AND TAG the electric heat coil power disconnect switch before working on or near heaters.  
Failure to follow these warnings could lead to personal injury or death.

## SERVICE

### General

1. Review Safety Considerations at beginning of these instructions. Good safety habits are important tools when performing service procedures.
2. To make speed measurements, use a laser-style tachometer.

### Fan Motor Replacement

**WARNING:** Shut off motor power and lock out power supply.

#### Remove Blower/Motor Assembly

Procedure:

1. Disconnect wiring harness plugs from motor (Fig. 16 and 17).
2. Remove blower mounting bolts, which secure the blower rails upward against the blower deck (2ea).
3. Remove motor/wheel assembly from the MMD unit by sliding out (Figure 18).
4. See Figure 19. Loosen shaft set screw (opposite motor side) and motor mount tightening screw until motor can be removed.
5. Remove motor. Install new motor (Fig. 20), tighten motor mount bolt, then locate fan wheel and tighten shaft set screw.
6. Reverse steps 1-4 to reinstall fan. Make sure that the two clips at the back hold the blower rails up against the blower deck.
7. Spin fan by hand to make sure there is no rubbing or interference.
8. Close unit access doors, remove lockout/tag out and restore the unit to operation.

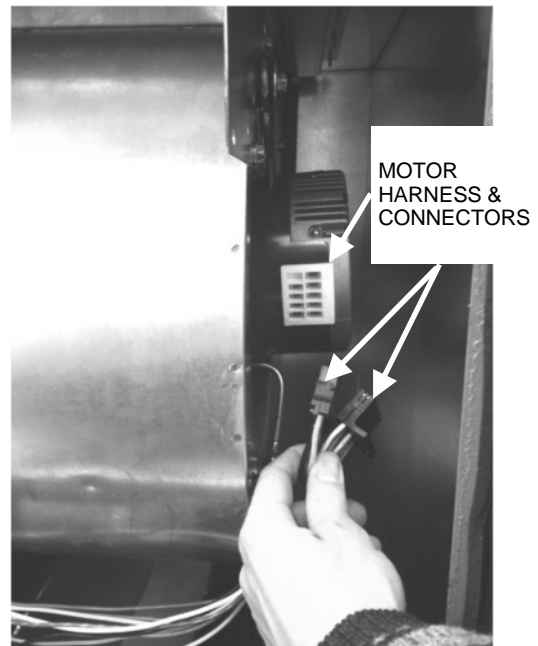

Figure 16

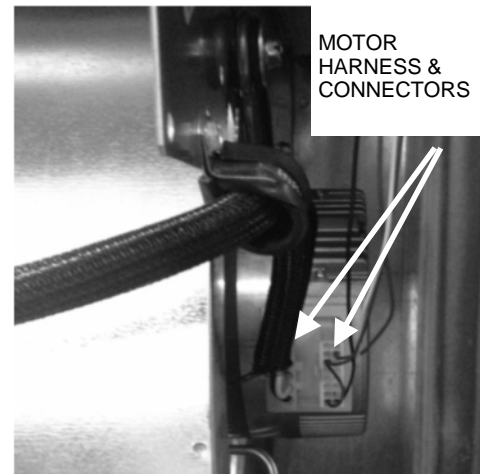

Figure 17

## DANGER

NEVER enter an enclosed fan cabinet or reach into a unit while the fan is running. LOCK OPEN AND TAG the fan motor disconnect switch before working on a fan. Take fuses with you and note removal on tag. Electric shock can cause personal injury or death. LOCK OPEN AND TAG the electric heat coil power disconnect switch before working on or near heaters. Failure to follow these warnings could lead to personal injury or death.

### Fan System Periodic Maintenance

1. Use of a Preventive Maintenance program is strongly recommended to insure that the unit operates safely and efficiently.
2. Motor bearings are permanently sealed and do not require lubrication.
3. Clean the fan's flow area - maintenance interval in accordance with the degree of contamination.
4. The fan wheel can be cleaned with a moist cloth.
5. Do not use any aggressive, paint solvent cleaning agents when cleaning.
6. Never use a high-pressure cleaner or water-spray for cleaning - particularly when the fan is running.

### Coil Cleaning

**DETERGENT** — Spray mild detergent solution on coils with garden-type sprayer. Rinse with fresh water. Check to ensure condensate line is free. Excess water from cleaning may flood unit if condensate line is plugged.



Figure 18

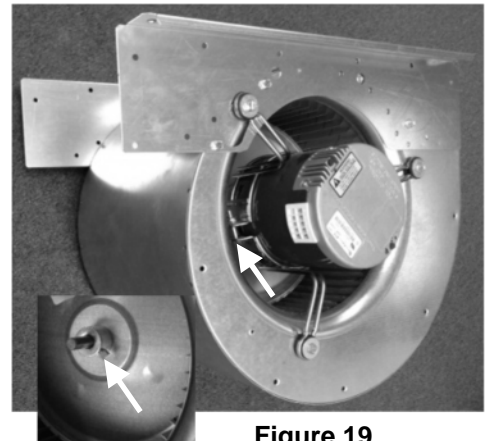

Figure 19

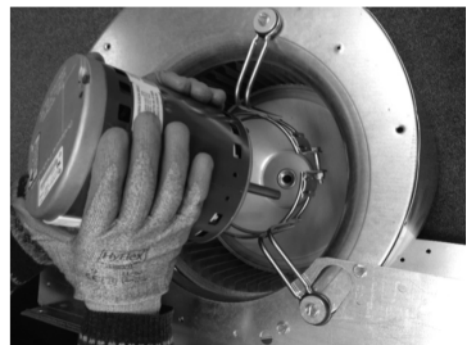
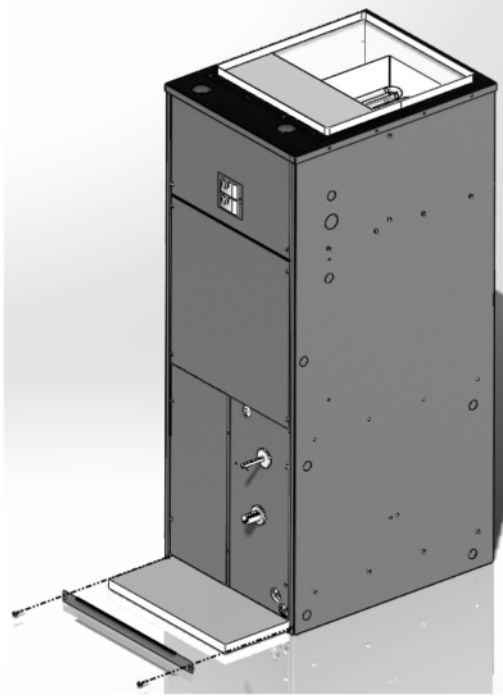

Figure 20

## SERVICE—Filters

### Filters

**FILTER SECTIONS** — Open or remove filter panel to replace old filter with a new filter. See physical data tables for filter data. See Figure 21.



**Figure 21**

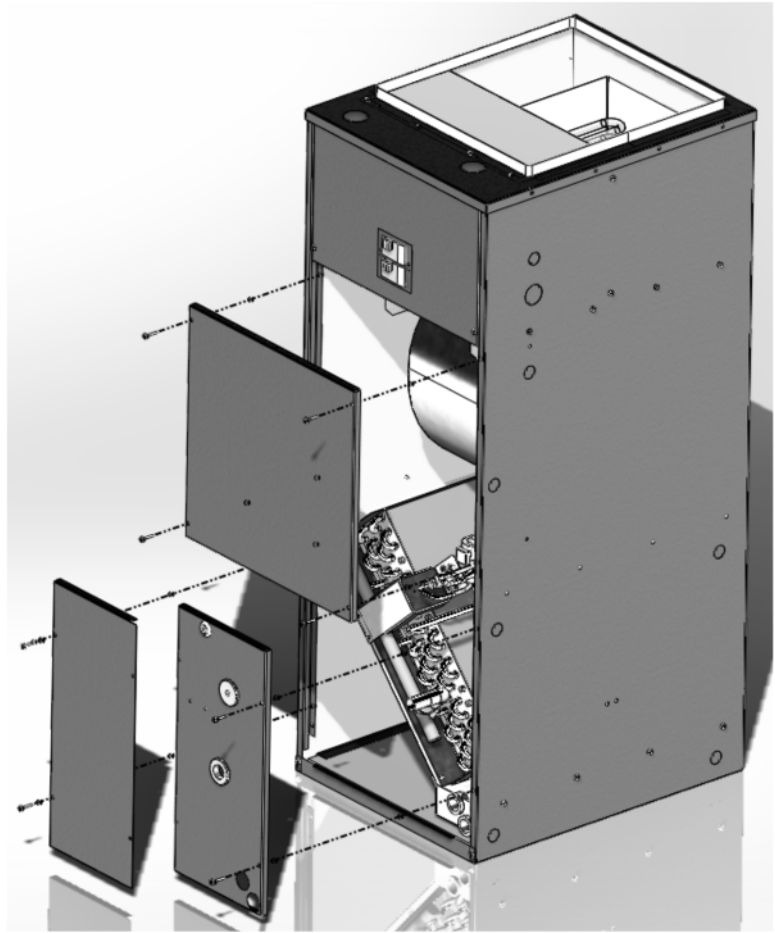

**Figure 22**

### Access Panels

The 3 sections of the unit can be reached using the front access panels, removable using 5/16" socket or driver or flat head screwdriver. See Figure 22.



## SERVICE-Coil Removal and Reinstallation Procedure

1. Perform procedure on the ground for safety. If working at heights USE EXTREME CAUTION observe all FALL SAFETY considerations. Under all conditions, LOCK OUT all power supplies before performing this procedure. WARNING! Coil section can be heavy—use proper lifting equipment.
2. Isolate coil and reclaim refrigerant. Disconnect unit from piping. Remove supply piping to allow access into the coil section from the front.
3. Remove blower access door and coil access doors.
4. Carefully remove temperature sensors from the coil and set them aside, clear of the coil & drain pan assembly. Disconnect pulse motor valve (PMV) wiring from the PMV.
5. Remove 4 screws on the drain pan side of the cabinet (right side shown in Fig. 23). Remove 4 screws from coil support side of the cabinet (left side shown in Fig. 23).
6. Slide coil & drain pan assembly out of the unit (Fig 19).
7. Coil can be detached from drain pan using 5/16" driver, 2 screws. Coil can be detached from coil support using 5/16" driver, 4 screws.
8. Follow instructions in reverse to install new coil.
9. Re-install sensors back in original positions. CAUTION! Be sure to place sensors in correct locations for proper unit operation.
10. Re-install wiring to PMV.
11. Re-install unit access panels.
12. Return unit to service.

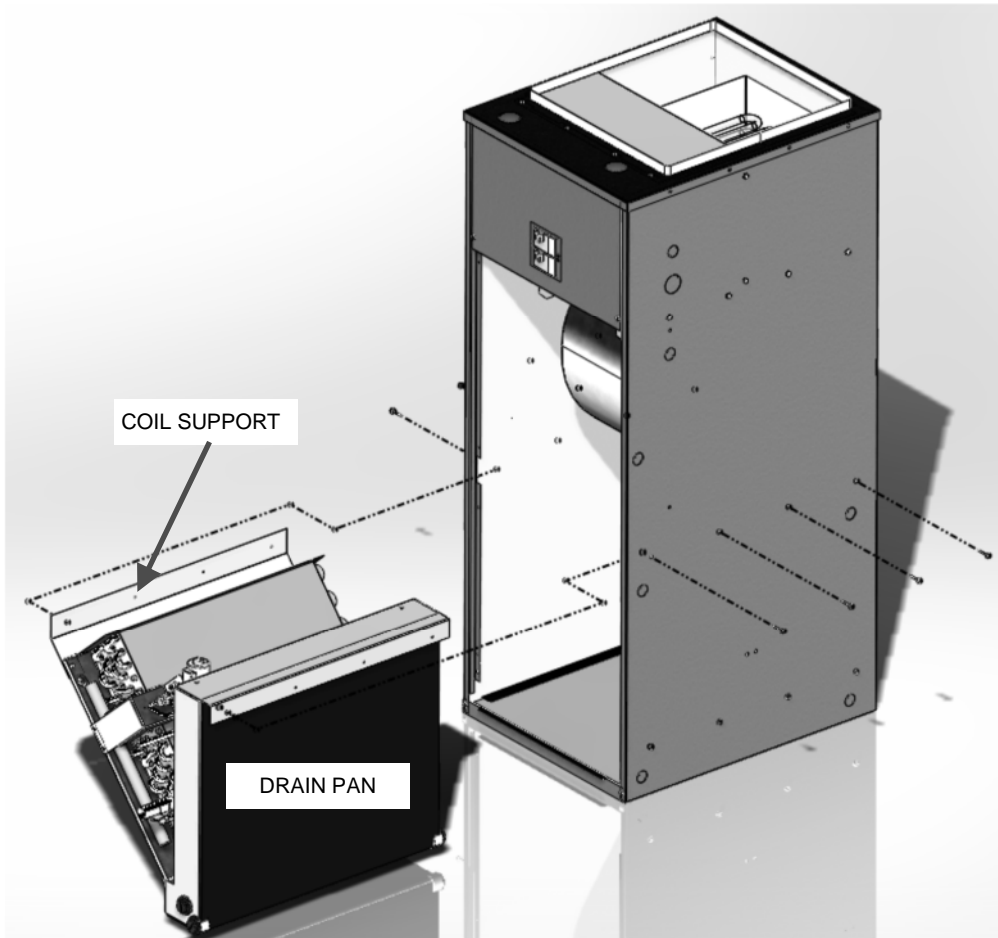
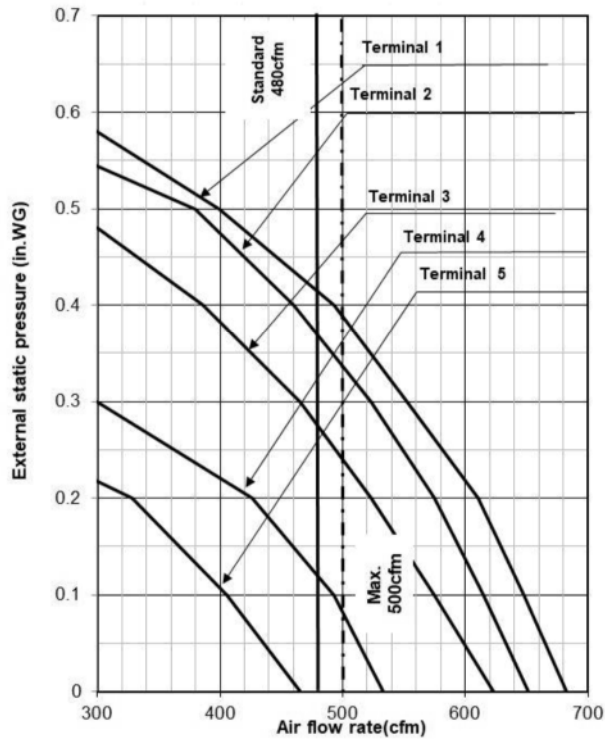

Figure 23

# AIRFLOW PERFORMANCE

MMD-AP0120VHG2UL(1ton)



MMD-AP0180VHG2UL(1.5ton)

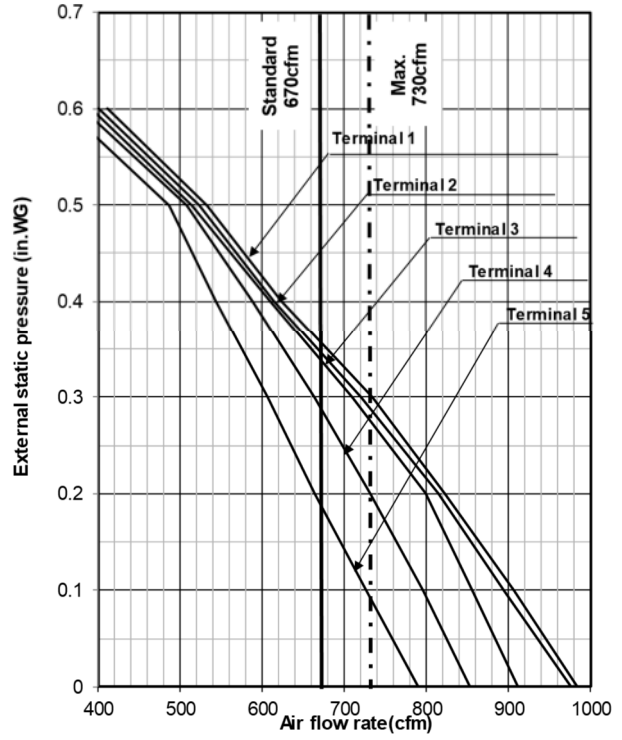

MMD-AP0240VHG2UL (2ton)

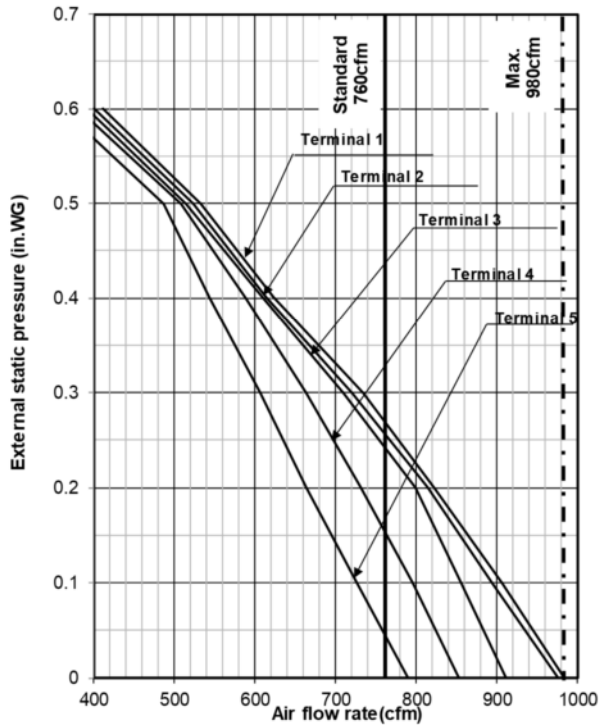

MMD-AP0300VHG2UL(2.5ton)

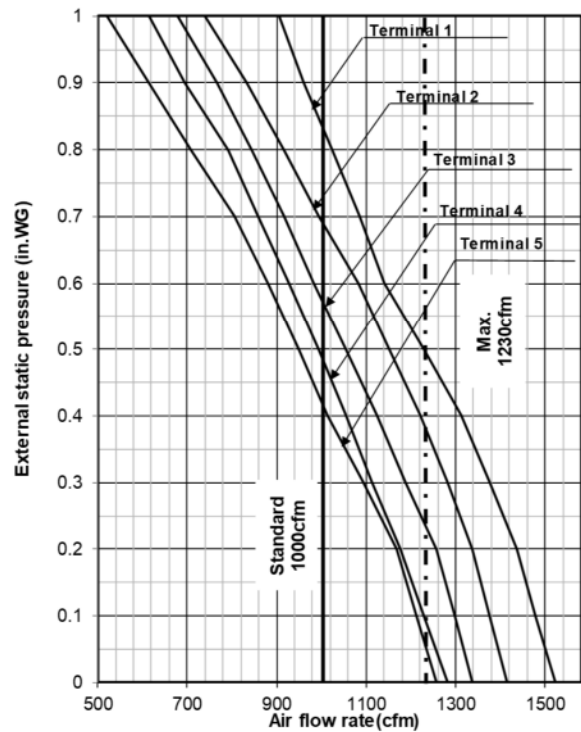

# AIRFLOW PERFORMANCE

MMD-AP0360VHG2UL(3ton)

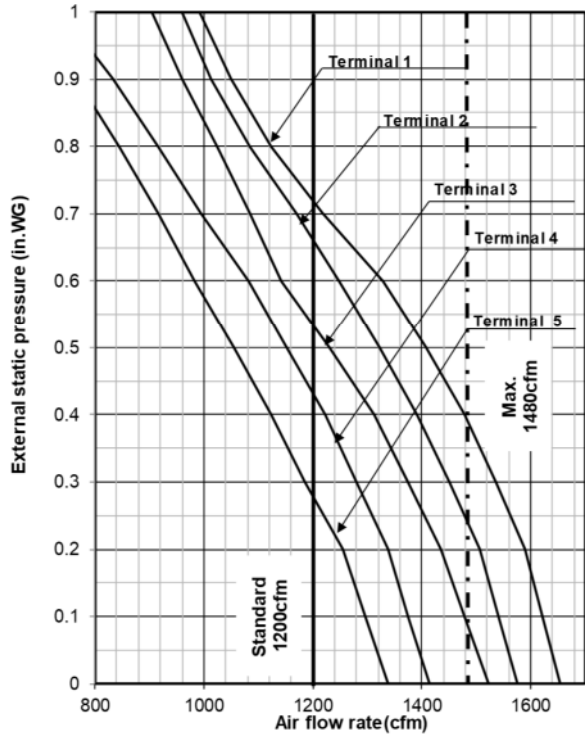

MMD-AP0420VHG2UL(3.5ton)

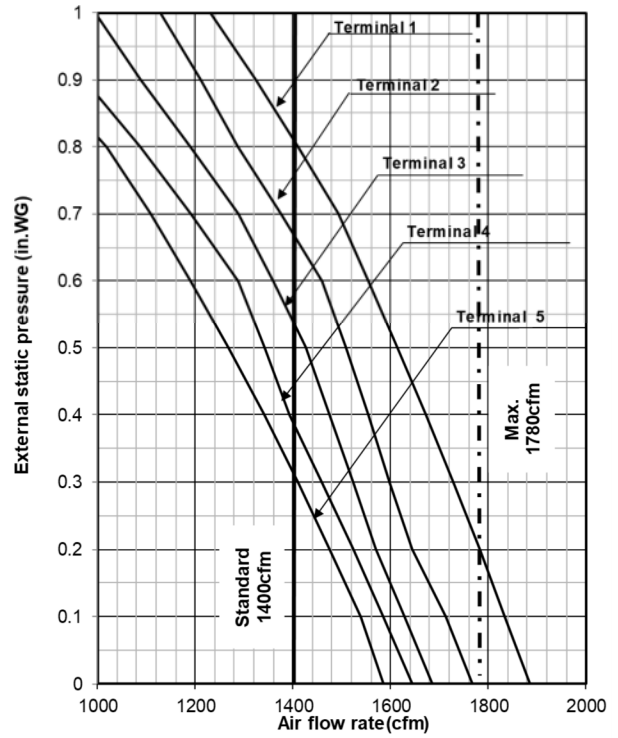

MMD-AP0480VHG2UL(4ton)

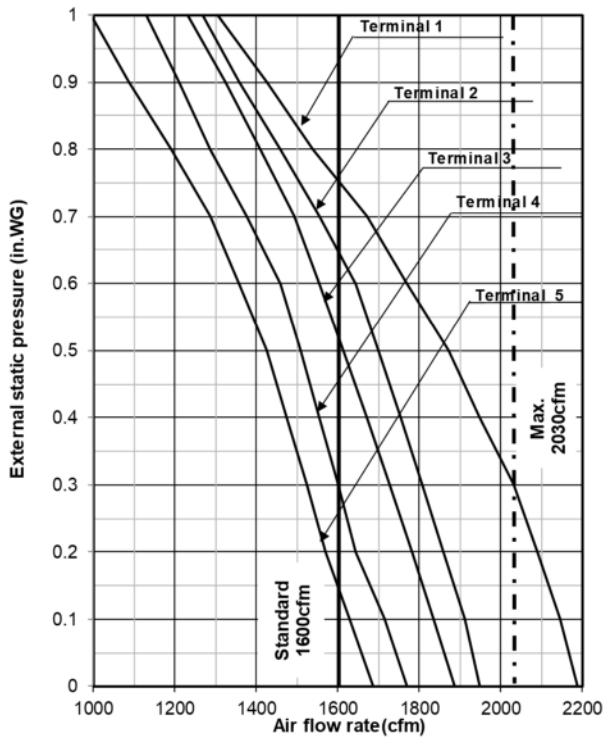

MMD-AP0600VHG2UL(5ton)

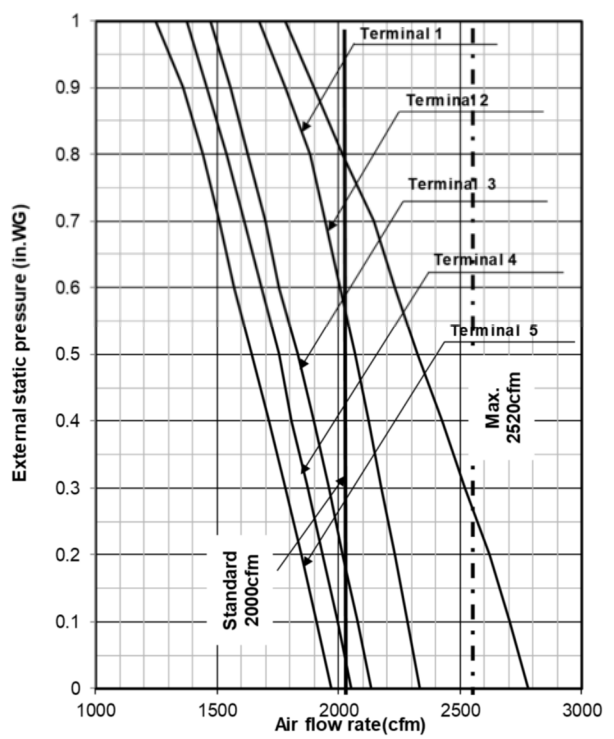

**UNIT ELECTRICAL RATINGS**

**MMD Electrical Data**

Unit Size	Motor HP	MOTOR FLA 240-208V	TOTAL ELECTRIC HT (KW)		ELECTRIC HEAT		UNIT FLA		MINIMUM CIRCUIT AMPACITY (MCA)		Maximum Overcurrent		MIN WIRE SIZE AWG*
			240	208	CIRCUIT 1		CIRCUIT 1		CIRCUIT 1		CIRCUIT 1		
					240	208	240	208	240	208	240	208	
MMD12	1/3	1.3	NONE		NONE		1.5	1.5	1.9	1.9	15	15	14
			1.0	0.8	4.2	3.6	5.5	4.9	6.8	6.1	15	15	14
			3.0	2.3	12.5	10.8	13.8	12.1	17.3	15.2	15	15	14
			5.0	3.8	20.8	18.1	22.1	19.4	27.7	24.2	30	25	10/12
MMD18 MMD24	1/3	2.2	NONE		NONE		2.2	2.2	2.8	2.8	15	15	14
			1.0	0.8	4.2	3.6	6.4	5.8	8.0	7.3	15	15	14
			3.0	2.3	12.5	10.8	14.7	13.0	18.4	16.3	15	15	14
			5.0	3.8	20.8	18.1	23.0	20.3	28.8	25.3	30	25	10/12
			6.0	4.5	25.0	21.7	27.2	23.9	34.0	29.8	35	30	8/10
MMD30 MMD36	1/2	3.6	NONE		NONE		3.6	3.6	4.5	4.5	15	15	14
			1.0	0.8	4.2	3.6	7.8	7.2	9.7	9.0	15	15	14
			3.0	2.3	12.5	10.8	16.1	14.4	20.1	18.0	25	20	10
			5.0	3.8	20.8	18.1	24.4	21.7	30.5	27.1	35	30	8
			6.0	4.5	25.0	21.7	28.6	25.3	35.8	31.6	40	35	8
			8.0	6.0	33.3	28.9	36.9	32.5	46.2	40.6	50	45	8
			9.5	7.1	39.6	34.3	43.2	37.9	54.0	47.4	60	50	6
MMD42	3/4	4.9	NONE		NONE		4.9	4.9	6.1	6.1	15	15	14
			1.0	0.8	4.2	3.6	9.1	8.5	11.3	10.6	15	15	14
			3.0	2.3	12.5	10.8	17.4	15.7	21.8	19.7	25	20	10
			5.0	3.8	20.8	18.1	25.7	23.0	32.2	28.7	35	30	10
			6.0	4.5	25.0	21.7	29.9	26.6	37.4	33.2	40	35	8
			8.0	6.0	33.3	28.9	38.2	33.8	47.8	42.2	50	45	8
			9.5	7.1	39.6	34.3	44.5	39.2	55.6	49.0	60	50	6
MMD48	3/4	6.0	NONE		NONE		6.0	6.0	7.5	7.5	15	15	14
			1.0	0.8	4.2	3.6	10.2	9.6	12.7	12.0	15	15	14
			3.0	2.3	12.5	10.8	18.5	16.8	23.1	21.0	25	25	10
			5.0	3.8	20.8	18.1	26.8	24.1	33.5	30.1	35	35	10
			6.0	4.5	25.0	21.7	31.0	27.7	38.8	34.6	40	35	8
			8.0	6.0	33.3	28.9	39.3	34.9	49.2	43.6	50	45	8
			9.5	7.1	39.6	34.3	45.6	40.3	57.0	50.4	60	60	6
MMD60	1	7.6	NONE		NONE		7.6	7.6	9.5	9.5	15	15	14
			1.0	0.8	4.2	3.6	11.8	11.2	14.7	14.0	15	15	14
			3.0	2.3	12.5	10.8	20.1	18.4	25.1	23.0	30	25	10
			5.0	3.8	20.8	18.1	28.4	25.7	35.5	32.1	40	35	8
			6.0	4.5	25.0	21.7	32.6	29.3	40.8	36.6	45	40	8
			8.0	6.0	33.3	28.9	40.9	36.5	51.2	45.6	60	50	6
			9.5	7.1	39.6	34.3	47.2	41.9	59.0	52.4	60	60	6

Notes:

\*1. Minimum Wire Gauge is based upon Circuit 1 ampacity and the use of 75C wire at the unit.

**UNIT DIMENSIONS**

**MMD12-60 Elec Heat Ready  
RH Drain Connections, Bottom Return**

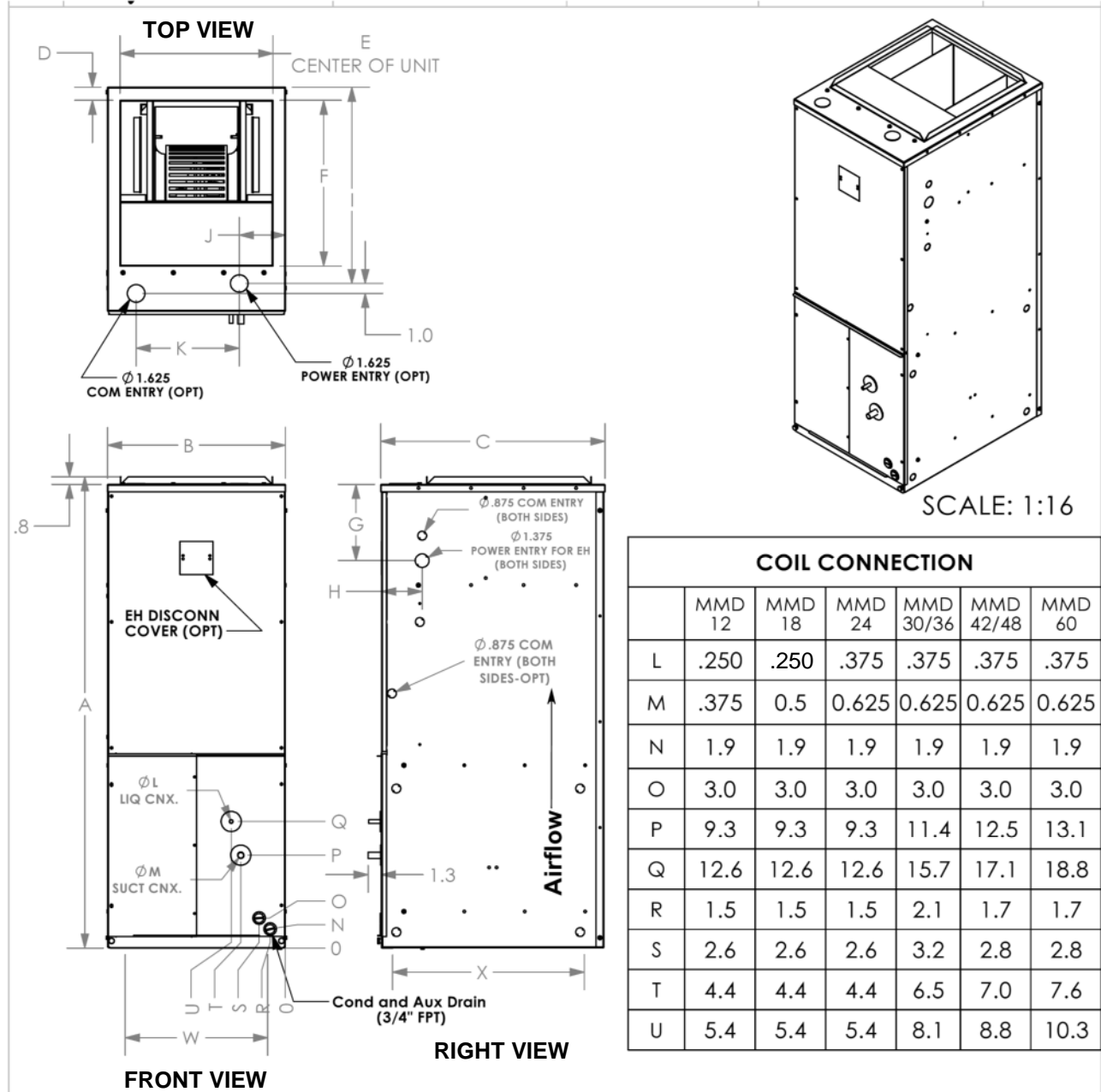

COIL CONNECTION						
	MMD 12	MMD 18	MMD 24	MMD 30/36	MMD 42/48	MMD 60
L	.250	.250	.375	.375	.375	.375
M	.375	0.5	0.625	0.625	0.625	0.625
N	1.9	1.9	1.9	1.9	1.9	1.9
O	3.0	3.0	3.0	3.0	3.0	3.0
P	9.3	9.3	9.3	11.4	12.5	13.1
Q	12.6	12.6	12.6	15.7	17.1	18.8
R	1.5	1.5	1.5	2.1	1.7	1.7
S	2.6	2.6	2.6	3.2	2.8	2.8
T	4.4	4.4	4.4	6.5	7.0	7.6
U	5.4	5.4	5.4	8.1	8.8	10.3

ALL UNITS IN INCHES	HEIGHT	WIDTH	DEPTH	DISCHARGE DUCT			ELECTRICAL CONN.					RETURN OPENING	
				D	E	F	G	H	I	J	K	W	X
MODEL	A	B	C	D	E	F	G	H	I	J	K	W	X
MMD12/18/24	46.9	17.7	22.3	1.3	15.2	16.4	7.6	4.0	19.5	4.6	10.2	14.1	19.0
MMD30/36	51.9	20.2	25.3	1.6	17.2	19.1	7.6	4.0	22.5	4.9	11.5	16.6	22.2
MMD42/48	55.9	22.2	27.3	1.6	19.2	21.2	7.6	4.0	24.4	5.8	12.7	18.0	23.7
MMD60	57.9	24.2	31.3	1.6	21.2	25.2	7.6	4.0	28.3	5.8	15.6	18.0	27.0

PRODUCT INFORMATION IS SUBJECT TO CHANGE WITHOUT NOTICE

**UNIT DIMENSIONS**

**MMD12-60 Elec Heat Ready  
RH Drain Connections, LH Return**

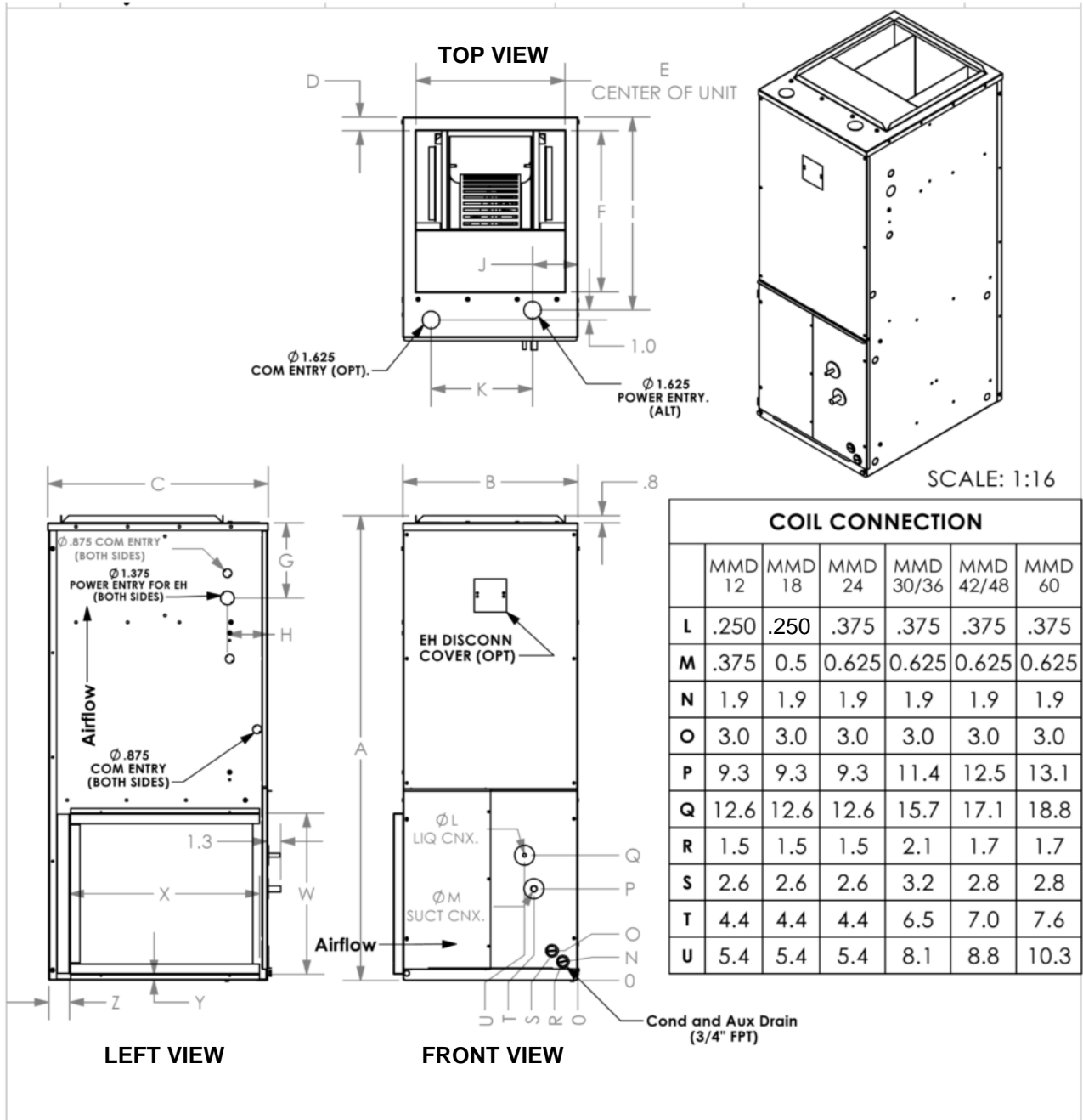

COIL CONNECTION						
	MMD 12	MMD 18	MMD 24	MMD 30/36	MMD 42/48	MMD 60
L	.250	.250	.375	.375	.375	.375
M	.375	0.5	0.625	0.625	0.625	0.625
N	1.9	1.9	1.9	1.9	1.9	1.9
O	3.0	3.0	3.0	3.0	3.0	3.0
P	9.3	9.3	9.3	11.4	12.5	13.1
Q	12.6	12.6	12.6	15.7	17.1	18.8
R	1.5	1.5	1.5	2.1	1.7	1.7
S	2.6	2.6	2.6	3.2	2.8	2.8
T	4.4	4.4	4.4	6.5	7.0	7.6
U	5.4	5.4	5.4	8.1	8.8	10.3

ALL UNITS IN INCHES	HEIGHT	WIDTH	DEPTH	DISCHARGE DUCT			ELECTRICAL CONN.					RETURN DUCT			
				D	E	F	G	H	I	J	K	W	X	Y	Z
MODEL	A	B	C	D	E	F	G	H	I	J	K	W	X	Y	Z
MMD 12/18/24	46.9	17.7	22.3	1.3	15.2	16.4	7.6	4.0	19.5	4.6	10.2	16.3	19.2	0.6	1.3
MMD30/36	51.9	20.2	25.3	1.6	17.2	19.1	7.6	4.0	22.5	4.9	11.5	18.2	23.3	2.8	0.4
MMD42/48	55.9	22.2	27.3	1.6	19.2	21.2	7.6	4.0	24.4	5.8	12.7	21.0	24.2	0.9	0.9
MMD60	57.9	24.2	31.3	1.6	21.2	25.2	7.6	4.0	28.3	5.8	15.6	21.0	28.8	2.0	0.4

PRODUCT INFORMATION IS SUBJECT TO CHANGE WITHOUT NOTICE

**SPECIAL FACTORY OPTIONS**

Option Descriptions Table	
Descriptions	Option Number
Factory Installed Heater - 1kW	1
Factory Installed Heater - 3kW	2
Factory Installed Heater - 5kW	3
Factory Installed Heater - 6kW	4
Factory Installed Heater - 8kW	5
Factory Installed Heater - 9.5kW	6
Left Hand Unit	7
Foil Faced Fiberglass Insulation, 1/2" thick	8
Stainless Steel Drain Pan	9

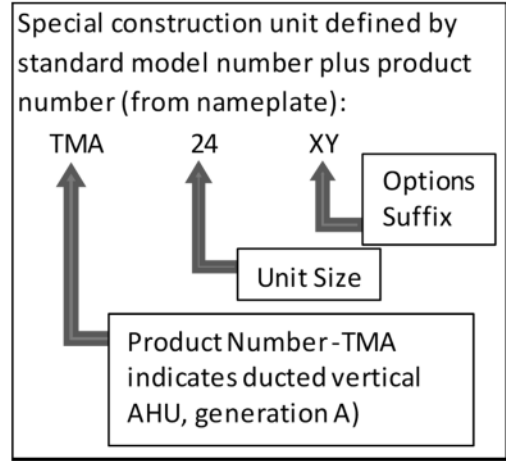

Options Suffix Table			
Digit XY	Includes Option Number(s)	Digit XY	Includes Option Number(s)
AA	No Options	CL	7, 8
BB	1	CM	7, 9
BC	2	CN	8, 9
BD	3	CP	1, 7, 8
BF	4	CR	2, 7, 8
BG	5	CS	3, 7, 8
BH	6	CT	4, 7, 8
BJ	7	CV	5, 7, 8
BK	8	CW	6, 7, 8
BL	9	CY	1, 7, 9
BM	1, 7	CZ	2, 7, 9
BN	2, 7	DB	3, 7, 9
BP	3, 7	DC	4, 7, 9
BR	4, 7	DD	5, 7, 9
BS	5, 7	DF	6, 7, 9
BT	6, 7	DG	1, 8, 9
BV	1, 8	DH	2, 8, 9
BW	2, 8	DJ	3, 8, 9
BY	3, 8	DK	4, 8, 9
BZ	4, 8	DL	5, 8, 9
CB	5, 8	DM	6, 8, 9
CC	6, 8	DN	7, 8, 9
CD	1, 9	DP	1, 7, 8, 9
CF	2, 9	DR	2, 7, 8, 9
CG	3, 9	DS	3, 7, 8, 9
CH	4, 9	DT	4, 7, 8, 9
CJ	5, 9	DV	5, 7, 8, 9
CK	6, 9	DW	6, 7, 8, 9

## ELECTRICAL WORK

### WARNING

---

- **Securely connect the specified wires so that the external tension does not affect the terminal connectors.**

Improper connection may cause an electric shock or a fire.

- **Connect earth grounding wire.**

Incomplete grounding will cause an electric shock.

Do not connect ground wires to gas pipes, water pipes, lightning rods, or the grounding wires of telephone lines.

- **Appliance shall be installed in accordance with national wiring regulations.**

Capacity shortage of power circuit or incomplete installation may cause an electric shock or a fire.

### CAUTION

---

- If wiring is incorrect or incomplete, it may cause an electrical fire.
- Install an earth leakage breaker that is not tripped by shock waves.  
If an earth leakage breaker is not installed, an electric shock may occur.
- Use the cord clamps attached to the product.
- Do not damage or scratch the conductive core, power inner insulator, or inter connecting wires  
When stripping them.
- Use the power cord and inter connecting wire of specified type and thickness, protective devices required.
- Never connect 208-230V power to the terminal blocks (U1/U2, A/B, etc) for control wiring, or the system will fail.

#### **REQUIREMENT:**

- For power supply wiring, strictly conform to the Local Regulation for each country.
- After connecting wires to the terminal blocks, provide a trap and secure wires with cable clamps.

## **Power supply wires and communication wires specifications**

---

Power supply wires and communication wires are procured locally.

Follow to the table below for the power supply specifications. If capacity is small overheating or seizure is likely.

For the power capacity of the outdoor unit and the power supply wires specifications, refer to the outdoor unit's installation manual.

### **Vertical air handling unit power supply**

- Make sure this indoor unit power supply is separated from that of the outdoor unit's power supply.
- Arrange the power supply, earth leakage breaker, and main switch of this indoor unit so they are connected to the same outdoor unit.



## SPECIAL INSTRUCTIONS—ELECTRICAL WORK

### ▼ Power supply

Power supply	208 / 230V 1ph 60Hz
Wire size	Refer to “MMD electrical data” table
Power supply wiring	Up to 164’1” (50m)

### ▼ Control wiring, Central control wiring

- 2-core shielded wires (non-polarity) are used for the control wiring between the indoor and outdoor units and central control wiring.
- The length of the communication line is the total length of the inter unit wire between the indoor and outdoor units added to the central control system wire length.

### ▼ VRF Communication Line (U1/U2)

VRF Control wiring between indoor unit and outdoor unit (2-core shield wire)	Wire Size	(Up to 3280’10” (1000m)) AWG16 (Up to 6561’8” (2000m)) AWG14
Central control line wiring (2-core shield wire)	Wire Size	(Up to 3280’10” (1000m)) AWG16 (Up to 6561’8” (2000m)) AWG14

### ▼ Remote controller wiring (A/B)

Remote control wiring, remote controller inter-unit wiring	2-core, non-polarity, Wire size: AWG20	
Total wire length of remote control wiring and remote control inter-unit wiring = L + L1 + L2 + ... Ln	In case of wired type only	Up to 1650’5” (500m) Up to 984’3” (300m) in case of two remote control by RBC-AMS54E-UL
	In case of wireless type included	Up to 1312’4” (400m)
Total wire length of remote control inter-unit wiring = L1 + L2..Ln	Up to 656’2” (200m)	

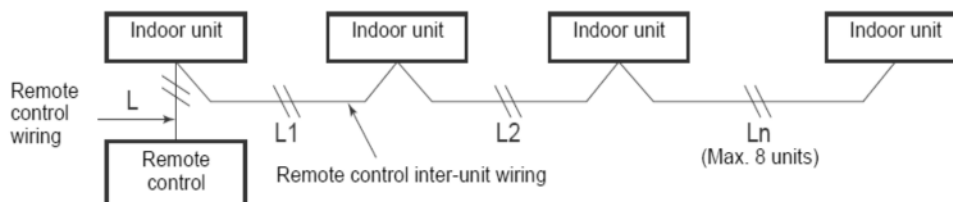

### NOTE

- Use copper supply wire.
- Use UL wire rated 600 V for the power supply.
- Use UL wire rated 300 V for the remote control wires and control wires.

## ■ Connection wiring

---

Connect power cables, earth wires, and communication cables to the specified terminals on the terminal block.

### ■ Power supply wiring and ground wire

1. Strip the wire ends.  
Power supply wire : 0.4" (10mm)
2. Match the wire colors with the terminal numbers on the units' and circuit breakers' terminal blocks and firmly screw the wires to the corresponding terminals.
3. Secure the ground wire with the ground screw.

### ■ Communication cables (U1/U2)

In a central control system, connect the copper braid shield of central control wire (2-core shielded wire).

1. Strip the wire ends  
Communication cable (U1/U2) : 0.4" (10mm)
2. Connect shield wire to the screw terminal.

---

 **CAUTION**

---

The remote control wire (communication line) and AC208/230V wires cannot be run in parallel, make contact stored in the same conduits, or noise may be caused in the control system.

### ■ Remote control wiring

- Since the remote control wire has non-polarity, the connections to the terminal blocks A and B may be reversed.
- For wiring and installation, refer to the installation manual enclosed to in the remote control.

#### ▼ Wiring diagram

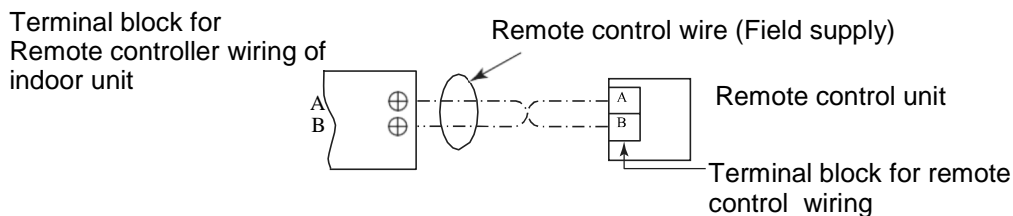

## ■ VRF Address Set Up

Set up the addresses as per the Installation manual supplied with the outdoor unit.

**SPECIAL INSTRUCTIONS—CONTROLS**

**■P.C. Board Optional Switch/Connector Specifications (MCC-1570)**

Function	Connector	Pin	Function	Remarks
<b>Fan output</b>	<b>CN32</b> (WHI)	1	DC12V (COM)	Factory default setting : ON when indoor unit in operation and OFF when indoor unit at rest. *Fan can be operated on its own by pressing FAN button on remote control (DN31)
		2	Fan Output	
<b>Float switch input</b>	<b>CN34</b> (RED)	1	COM (DC12V)	Error code P10, Normal close. (Short pin is connected as default)
		2		
		3	External safety contact	
<b>Optional output</b>	<b>CN60</b> (WHI)	1	DC12V (COM)	
		2	Defrosting output	ON while outdoor unit defrosted
		3	Thermostat ON output	ON while real thermostat ON
		4	Cooling output / auxiliary heating output	ON while air conditioner in cooling or related operation (COOL, DRY, or cooling under AUTO mode) By DN[DC] set as 0001 to 0010, this output become "auxiliary heating" output.
		5	Heating output	Cooling : Open, Heating : Close
		6	Fan output	ON while fan ON
<b>HA</b>	<b>CN61</b> (YEL)	1	ON/OFF input	Start/Stop input
		2	0V (COM) for pin 1, 3	
		3	Remote control disabling input	Enables/Disables start/stop control via remote control
		4	In-operation output	ON during operation
		5	DC12V (COM) for pin 4, 6	
		6	Alarm output	ON while alarm ON
	<b>CN70</b> (WHI)	1	Option	Option error input
		2	0V (COM)	
<b>CHK Operation check</b>	<b>CN71</b> (WHI)	1	Check mode input	Used for indoor operation check (prescribed operational status output, such as indoor fan "H", to be generated without communication with outdoor unit or remote controller).
		2	0V (COM)	
<b>DISP Display mode</b>	<b>CN72</b> (WHI)	1	Display mode input	Product display mode –Communication just between indoor unit and remote control becomes available (upon turning on of power) Timer short-circuited out (always)
		2	0V (COM)	
<b>EXCT Demand</b>	<b>CN73</b> (RED)	1	Demand input	Forced thermo-off input
		2	0V (COM)	
<b>External error input</b>	<b>CN80</b> (GRN)	1	COM (DC12V)	Error input from outside (Interlock, error code L30). Only if this condition continue more than 1 minute.
		2	COM (DC12V)	
		3	External error input	
<b>External output</b>	<b>CN510</b> (WHI)	1	<b>COM (DC12V)</b>	
		2	(no function)	
		3	<b>Fan tap "HH" output</b>	Fan Speed (High)
		4	(no function)	
		5	<b>Fan tap "H" output</b>	Fan Speed (Med)
		6	(no function)	
		7	<b>Fan tap "L" output</b>	Fan Speed (Low)
		8	(no function)	
		9	<b>Electrical heater output</b>	
		10-20	(No function)	

# ADVANCED CONTROL

## REQUIREMENT

- NOTE : Powering on the unit and interface for the first time, it takes time for the remote control to recognize the operation input. This is not a malfunction.
- For details on the auto address setting of air conditioners when operating together with VRF system (adjust the auto address setting on the circuit board of the outdoor interface).
- Turn on the indoor unit first. Refer to the installation manual of the air conditioner about its power supply.
- When shipped from the factory, all of the setting are set to [ Factory default ]. Change the setting using the main remote control (wired remote control).
- The settings cannot be changed using the wireless remote control, the sub remote control, or a system without a remote control (system with only the central remote control). Therefore, prepare the main remote control and install.

## ■ Functional setting by DN code



















### ■ Changing of settings for applicable controls (DN code setting)

#### Basic procedure for changing settings

Change the settings while the air conditioner is not working.

(Be sure to stop the air conditioner before making settings).



#### Procedure 1

1. Push the [  MENU ] button.
2. Push the [  MENU ] / [   ] button simultaneously for more than 4 seconds.
3. Push the [   ] / [   ] button to select “7. DN setting” on the “Field setting menu” screen.
4. Then push the [  F2 ] button.
5. Move the cursor to select “DN code” with the “<” [  F1 ] button.
6. Set “DN code” with the [   ] / [   ] button.
7. Move the cursor to select “data” with the [  F2 ] button, then set “data” with the [   ] / [   ] button.

#### Procedure 2

Refer to this installation manual for details about the DN code and data.

#### Procedure 3

1. Push the [  MENU ] button to set the other DN codes.
2. After “Continue?” is displayed on the screen, push the “Yes” [  F1 ] button.

#### Procedure 4

1. Push the “No” [  F2 ] button to finish the setting operation.
2. “⌚” appears on the screen for a while.
3. Then the screen returns to the “Field setting menu” screen.

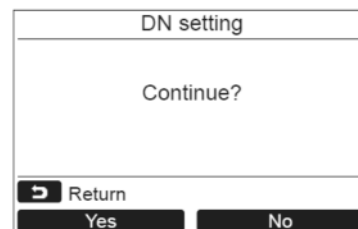

**SPECIAL INSTRUCTIONS—CONTROLS**

**■ Function code (DN code) setting**

DN Code	Items	Description	At shipment
01	Filter display delay timer	0000 : None 0001 : 150H 0002 : 2500H 0003 : 5000H 0004 : 10000H	0000 : None
02	Dirty state of filter	0000 : Standard 0001 : High degree of dirt (Half of standard time)	0000 : Standard
03	Central control address	0001 : No.1 unit to 0064 : No.64 unit, 0099 : Unfixed	0099 : Unfixed
04	Specific indoor unit priority	0000 : No priority 0001 : Priority	0000 : No priority
05	Constant fan	0001 : L tap during heating thermo-off 0012 : Fan tap by remote control set during heating thermo-off	0001 : L tap
06	Heating temp. shift	0000 : No shift 0001 : +1□ (+1.8□) 0002 : +2□ (+3.6□) to 0010 : +10□ (+18□) (Up to +6 recommended)	0002 : +2□ (+3.6□)
0d	Existence of [AUTO] mode	0000 : Provided 0001 : not provided (Automatic selection from connected outdoor unit)	0001 : Not provided
0E	FS unit connection set of multiple indoor units	0000 : Standard (1 FS unit : 1 indoor unit) 0001 : Multiple units connected ( 1 FS unit : Multiple indoor units)	0000 : Standard
0F	Cooling only	0000 : heat pump 0001 : Cooling only (no display of [AUTO] [HEAT])	0000 : Heat pump
10	Model code	0029 : Vertical air handling unit	0029
12	Line (System) address	0001: No.1 unit to 0030: No.30 unit	0099 : Unfixed
13	Indoor address	0001 : No.1 unit to 0064 : No.64 unit	0099 : Unfixed
14	Group address	0000 : Individual 0001 : Header unit of group 0002 : Follower unit of group	0099 : Unfixed
28	Automatic restart of power failure	0000 : None 0001 : Restart	0001 : Restart
2E	HA terminal (CN61) select	0000 : Usual 0001: Leaving-ON prevention control 0002 : Fire alarm input	0000 : Usual (HA terminal)
31	Ventilation fan control	0000 : Unavailable 0001 : Available	0000 : Unavailable
32	Remote control sensor	0000 : Body TA sensor 0001 : Remote control sensor	0000 : Body TA sensor
33	Temperature unit select	0000 : °C, 0001 : °F	0001 : °F
60	Timer setting (wired remote controller)	0000 : Available (Can be performed) 0001 : Unavailable (Cannot be performed)	0000 : Available
77	Dual set point	0000 : Unavailable 0002 : Available	0000 : Unavailable
FD	Priority operation mode (Flow selector unit)	0000 : Heating 0001 : Cooling	0000 : Heating
92	Alarm clearance condition	0000 : Operation stop 0001 : Release signal received	0000 : Operation stop
9B	Setting of "prevention of cold air discharge" control	0000 : Prevention control of cold air discharge "enable" 0001 : Prevention control of cold air discharge without "Fan off" zone 0002 : Work in remote control setting fan speed. (prevention control of cold air discharge "disable")	0000 : Enable





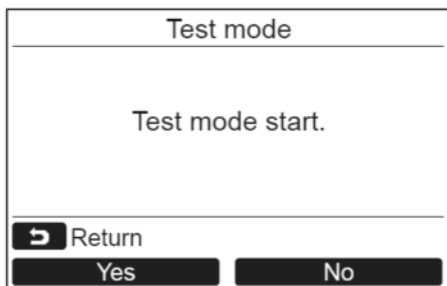
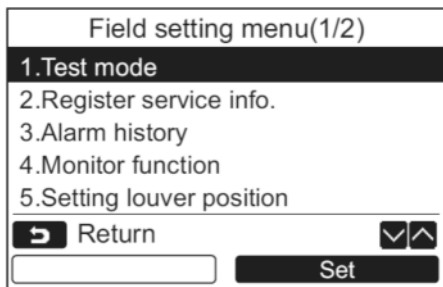

# TEST RUN

## Preparation

- Before turning on the power supply, carry out the following procedure.
  1. Using 500V-Megger, check the resistance between the terminal block of the power supply and the earth (grounding). The resistance must be 1MΩ or more.
  2. If resistance of less than 1MΩ is detected, do not run the unit.
- When a test run is performed together with air conditioners, follow the installation manuals of the air conditioners.
- Never press the electromagnetic contactor to forcibly perform the test run. (This would be very dangerous because the protective device does not work).
- Before starting a test run, be sure to set addresses per the installation manual supplied with the outdoor unit.







## Performing the test mode

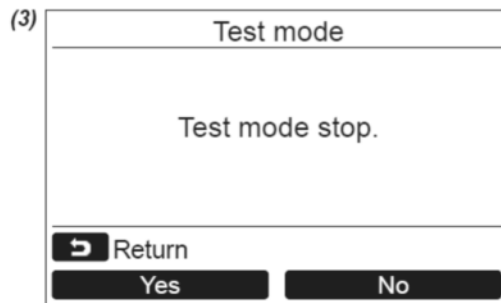
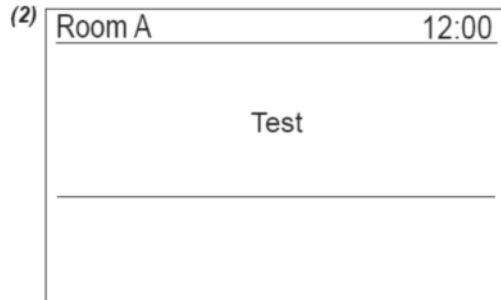
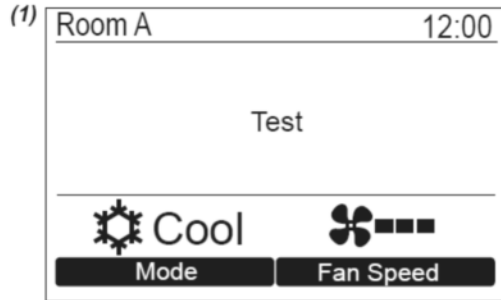

1. Push the [  **MENU** ] button to display the menu screen.
2. Push and hold the [  **MENU** ] button and the [  ] button at the same time to display the “Field setting menu”.  
→ Push and hold the buttons for more than 4 seconds.
3. Select “1 Test mode” on the “Field setting menu” screen, then push the “Set” [  **F2** ] button.  
→ Pushing the “Yes” [  **F1** ] button sets the test mode and the screen returns to the “Filed setting menu” screen.  
Push [  **CANCEL** ] twice, the screen (2) appears.

## SPECIAL INSTRUCTIONS—CONTROLS



4. Push the [  **ON/OFF** ] button to start the test mode. The screen (1) shown in the left appears. (The screen (2) appears when the operation is stops.)  
→ Perform the test mode in the “Cool” or “Heat” mode.
5. When test mode is finished, push the [   ] [   ] button to select “1. Test mode” on the “Field setting menu” screen, then push the “Set” [  **F2** ] button. The screen (3) appears.  
→ Pushing the “Yes” [  **F1** ] button stops the test mode screen and continues the normal operation.

Alternatively (using a wired remote controller), a forced test run can be executed in the procedure above mentioned even if the operation stops by thermo-OFF. In order to prevent a serial operation, the forced test run is released after 60 minutes have passed and returns to the usual operation.

---

### **CAUTION**

- Do not use the forced test run for cases other than the test run because it applies excessive load to the devices.
-



# TROUBLESHOOTING

## Confirmation and Check

---

When a malfunction occurs, please refer to the check code on the remote controller.

\*The check code appears only while the unit is running.

The check code is only displayed during the operation. Push the [  **MONITOR** ] button or [  **CANCEL** ] button to display the check information screen.

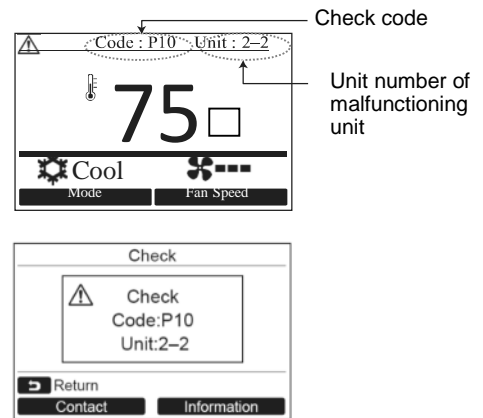



## SPECIAL INSTRUCTIONS—CONTROLS

### Check Codes and Parts to be Checked

#### Check method

On the remote control (Wired remote control, Central control remote control) and the interface P.C. board of the outdoor unit (I/F), a check display LCD (Remote control) or 7-segment display (on the outdoor interface P.C. board) to display the operation is provided. Therefore the operation status can be known. With this self-diagnosis function, a trouble or position with error of the air conditioner can be found as shown in the table below.

#### Check code list

The following list shows each check code. Find the check contents from the list according to part to be checked.

- To check from indoor remote control: See “Wired remote control display” in the list.
- To check from outdoor unit: See “Outdoor 7-segment display” in the list.
- To check from indoor unit with a wireless remote control: See “Sensor block display of receiving unit” in the list.

#### Legend

IPDU : Intelligent Power Drive Unit

- Lighting      ◻ Flashing      ● Goes off

ALT : Flashing is alternately when there are two flashing LED.  
SIM : Simultaneous flashing when there are two flashing LED.

Check code		Wireless remote control				Check code name	Judging device
Wired remote control display	Outdoor 7-segment display	Sensor block display of receiving unit					
	Auxiliary code	Operation	Timer	Ready	Flash		
E01	—	—	○	●	●	Communication error between indoor and remote control (Detected at remote control side)	Remote control
E02	—	—	○	●	●	Remote control transmission error	Remote control
E03	—	—	○	●	●	Communication error between indoor and remote control (Detected at indoor side)	Indoor
E04	—	—	●	●	◻	Communication circuit error between indoor / outdoor (Detected at indoor side)	Indoor
E06	E06	No. of indoor units in which sensor has been normally received	●	●	◻	Decrease of No. of indoor units	I/F
—	E07	—	●	●	◻	Communication circuit error between indoor / outdoor (Detected at outdoor side)	I/F
E08	E08	Duplicated indoor addresses	○	●	●	Duplicated indoor addresses	Indoor / I/F
E09	—	—	○	●	●	Duplicated header remote controls	Remote control
E10	—	—	○	●	●	Communication error between indoor MCU	Indoor
E12	E12	01: Indoor / Outdoor communication 02: Communication between outdoor units	○	●	●	Automatic address start error	I/F
E15	E15	—	●	●	◻	Indoor is nothing during automatic addressing	I/F
E16	E16	00: Capacity over 01 ~:No. of connected units	●	●	◻	Capacity over / No. of connected indoor units Combined capacity of indoor units exceeds 120% of combined capacity of outdoor units.	I/F
E18	—	—	○	●	●	Communication error between indoor units	Indoor
E19	E19	00: Header is nothing 02: Two or more header units	●	●	◻	Outdoor header units quantity error	I/F
E20	E20	01: Outdoor of other line connected 02: Indoor of other line connected	●	●	◻	Other line connected during automatic address	I/F
E23	E23	—	●	●	◻	Sending error in communication between outdoor units	I/F
E25	E25	—	●	●	◻	Duplicated follower outdoor addresses	I/F
E26	E26	No. of outdoor units which received signal normally	●	●	◻	Decrease of No. of connected outdoor units	I/F
E28	E28	Detected outdoor unit number	●	●	◻	Follower outdoor unit error	I/F

# SPECIAL INSTRUCTIONS—CONTROLS

Check code		Wireless remote control				Check code name	Judging device																																																																																						
Wired remote control display	Outdoor 7-segment display			Sensor block display of receiving unit																																																																																									
	Auxiliary code			Operation	Timer			Ready	Flash																																																																																				
E31	E31	<table border="1"> <thead> <tr> <th rowspan="2"></th> <th colspan="3">A3-IPDU</th> <th rowspan="2">Fan IPDU</th> </tr> <tr> <th>1</th> <th>2</th> <th>3</th> </tr> </thead> <tbody> <tr><td>01</td><td>○</td><td></td><td></td><td></td></tr> <tr><td>02</td><td></td><td>○</td><td></td><td></td></tr> <tr><td>03</td><td>○</td><td>○</td><td></td><td></td></tr> <tr><td>04</td><td></td><td></td><td>○</td><td></td></tr> <tr><td>05</td><td>○</td><td></td><td>○</td><td></td></tr> <tr><td>06</td><td></td><td>○</td><td>○</td><td></td></tr> <tr><td>07</td><td>○</td><td>○</td><td>○</td><td></td></tr> <tr><td>08</td><td></td><td></td><td></td><td>○</td></tr> <tr><td>09</td><td>○</td><td></td><td></td><td>○</td></tr> <tr><td>0A</td><td></td><td>○</td><td></td><td>○</td></tr> <tr><td>0B</td><td>○</td><td>○</td><td></td><td>○</td></tr> <tr><td>0C</td><td></td><td></td><td>○</td><td>○</td></tr> <tr><td>0D</td><td>○</td><td></td><td>○</td><td>○</td></tr> <tr><td>0E</td><td></td><td>○</td><td>○</td><td>○</td></tr> <tr><td>0F</td><td>○</td><td>○</td><td>○</td><td>○</td></tr> </tbody> </table>				A3-IPDU			Fan IPDU	1	2	3	01	○				02		○			03	○	○			04			○		05	○		○		06		○	○		07	○	○	○		08				○	09	○			○	0A		○		○	0B	○	○		○	0C			○	○	0D	○		○	○	0E		○	○	○	0F	○	○	○	○	●	●	○		IPDU communication error	I/F
			A3-IPDU			Fan IPDU																																																																																							
			1	2	3																																																																																								
		01	○																																																																																										
		02		○																																																																																									
		03	○	○																																																																																									
		04			○																																																																																								
		05	○		○																																																																																								
		06		○	○																																																																																								
		07	○	○	○																																																																																								
		08				○																																																																																							
		09	○			○																																																																																							
		0A		○		○																																																																																							
		0B	○	○		○																																																																																							
		0C			○	○																																																																																							
		0D	○		○	○																																																																																							
		0E		○	○	○																																																																																							
0F	○	○	○	○																																																																																									
F01	—	—	○	○	●	ALT	Indoor TCJ sensor error	Indoor																																																																																					
F02	—	—	○	○	●	ALT	Indoor TC2 sensor error	Indoor																																																																																					
F03	—	—	○	○	●	ALT	Indoor TC1 sensor error	Indoor																																																																																					
F04	F04	—	○	○	○	ALT	TD1 sensor error	I/F																																																																																					
F05	F05	—	○	○	○	ALT	TD2 sensor error	I/F																																																																																					
F06	F06	TE1 sensor TE2 sensor	○	○	○	ALT	TE1 sensor error TE2 sensor error	I/F																																																																																					
F07	F07	—	○	○	○	ALT	TL sensor error	I/F																																																																																					
F08	F08	—	○	○	○	ALT	TO sensor error	I/F																																																																																					
F10	—	—	○	○	●	ALT	Indoor TA sensor error	Indoor																																																																																					
F12	F12	—	○	○	○	ALT	TS1 sensor error	I/F																																																																																					
F13	F13	01: Comp. 1 side 02: Comp. 2 side 03: Comp. 3 side	○	○	○	ALT	TH sensor error	IPDU																																																																																					
F15	F15	—	○	○	○	ALT	Outdoor temp. sensor miswiring (TE1, TL)	I/F																																																																																					
F16	F16	—	○	○	○	ALT	Outdoor pressure sensor miswiring (Pd, Ps)	I/F																																																																																					
F22	F22	—	○	○	○	ALT	TD3 error	I/F																																																																																					
F23	F23	—	○	○	○	ALT	Ps sensor error	I/F																																																																																					
F24	F24	—	○	○	○	ALT	Pd sensor error	I/F																																																																																					
F29	—	—	○	○	●	SIM	Indoor other error	Indoor																																																																																					
F31	F31	—	○	○	○	SIM	Indoor EEPROM error	I/F																																																																																					
H01	H01	01: Comp. 1 side 02: Comp. 2 side 03: Comp. 3 side	●	○	●		Compressor break down	IPDU																																																																																					
H02	H02	01: Comp. 1 side 02: Comp. 2 side 03: Comp. 3 side	●	○	●		Compressor trouble (lock)	IPDU																																																																																					
H03	H03	01: Comp. 1 side 02: Comp. 2 side 03: Comp. 3 side	●	○	●		Current detect circuit system error	IPDU																																																																																					
H05	H05	—	●	○	●		TD1 miswiring	I/F																																																																																					
H06	H06	—	●	○	●		Low pressure protective operation	I/F																																																																																					
H07	H07	—	●	○	●		Oil level down detective protection	I/F																																																																																					
H08	H08	01: TK1 sensor error 02: TK2 sensor error 03: TK3 sensor error 04: TK4 sensor error	●	○	●		Oil level detective temp sensor error	I/F																																																																																					
H15	H15	—	●	○	●		TD2 miswiring	I/F																																																																																					

# SPECIAL INSTRUCTIONS—CONTROLS

Check code		Wireless remote control				Check code name	Judging device																																																																																				
Wired remote control display	Outdoor 7-segment display		Sensor block display of receiving unit																																																																																								
	Auxiliary code	Operation	Timer	Ready	Flash																																																																																						
H16	H16	01: TK1 oil circuit system error 02: TK2 oil circuit system error 03: TK3 oil circuit system error 04: TK4 oil circuit system error	●	○	●		Oil level detective circuit error	I/F																																																																																			
H25	H25	—	●	○	●		TD3 miswiring	I/F																																																																																			
L03	—	—	○	●	○	SIM	Indoor center unit duplicated	Indoor																																																																																			
L04	L04	—	○	○	○	SIM	Outdoor line address duplicated	I/F																																																																																			
L05	—	—	○	●	○	SIM	Duplicated indoor units with priority (Displayed in indoor unit with priority)	I/F																																																																																			
L06	L06	No. of indoor units with priority	○	●	○	SIM	Duplicated indoor units with priority (Displayed in unit other than indoor unit with priority)	I/F																																																																																			
L07	—	—	○	●	○	SIM	Group line in individual indoor unit	Indoor																																																																																			
L08	L08	—	○	●	○	SIM	Indoor group / Address unset	Indoor, I/F																																																																																			
L09	—	—	○	●	○	SIM	Indoor capacity unset	Indoor																																																																																			
L10	L10	—	○	○	○	SIM	Outdoor capacity unset	I/F																																																																																			
L17	L17	—	○	○	○	SIM	Outdoor unit model unmatched error	I/F																																																																																			
L20	—	—	○	○	○	SIM	Duplicated central control addresses	Indoor																																																																																			
L28	L28	—	○	○	○	SIM	Over No. of connected outdoor units	I/F																																																																																			
L29	L29	<table border="1"> <thead> <tr> <th rowspan="2"></th> <th colspan="3">A3-IPDU</th> <th rowspan="2">Fan IPDU</th> </tr> <tr> <th>1</th> <th>2</th> <th>3</th> </tr> </thead> <tbody> <tr><td>01</td><td>○</td><td></td><td></td><td></td></tr> <tr><td>02</td><td></td><td>○</td><td></td><td></td></tr> <tr><td>03</td><td>○</td><td>○</td><td></td><td></td></tr> <tr><td>04</td><td></td><td></td><td>○</td><td></td></tr> <tr><td>05</td><td>○</td><td></td><td>○</td><td></td></tr> <tr><td>06</td><td></td><td>○</td><td>○</td><td></td></tr> <tr><td>07</td><td>○</td><td>○</td><td>○</td><td></td></tr> <tr><td>08</td><td></td><td></td><td></td><td>○</td></tr> <tr><td>09</td><td>○</td><td></td><td></td><td>○</td></tr> <tr><td>0A</td><td></td><td>○</td><td></td><td>○</td></tr> <tr><td>0B</td><td>○</td><td>○</td><td></td><td>○</td></tr> <tr><td>0C</td><td></td><td></td><td>○</td><td>○</td></tr> <tr><td>0D</td><td>○</td><td></td><td>○</td><td>○</td></tr> <tr><td>0E</td><td></td><td>○</td><td>○</td><td>○</td></tr> <tr><td>0F</td><td>○</td><td>○</td><td>○</td><td>○</td></tr> </tbody> </table> <p>○ : IPDU error</p>		A3-IPDU			Fan IPDU	1	2	3	01	○				02		○			03	○	○			04			○		05	○		○		06		○	○		07	○	○	○		08				○	09	○			○	0A		○		○	0B	○	○		○	0C			○	○	0D	○		○	○	0E		○	○	○	0F	○	○	○	○	○	●	○	SIM	No. of IPDU error	I/F
	A3-IPDU			Fan IPDU																																																																																							
	1	2	3																																																																																								
01	○																																																																																										
02		○																																																																																									
03	○	○																																																																																									
04			○																																																																																								
05	○		○																																																																																								
06		○	○																																																																																								
07	○	○	○																																																																																								
08				○																																																																																							
09	○			○																																																																																							
0A		○		○																																																																																							
0B	○	○		○																																																																																							
0C			○	○																																																																																							
0D	○		○	○																																																																																							
0E		○	○	○																																																																																							
0F	○	○	○	○																																																																																							
L30	L30	Detected indoor address	○	○	○	SIM	Indoor outside interlock	Indoor																																																																																			
—	L31	—	—	—	—		Extended I/C error	I/F																																																																																			
P01	—	—	●	○	○	ALT	Indoor fan motor error	Indoor																																																																																			
P03	P03	—	○	●	○	ALT	Discharge temp. TD1 error	I/F																																																																																			
P04	P04	01: Comp. 1 side 02: Comp. 2 side 03: Comp. 3 side	○	●	○	ALT	High-pressure SW system operation	IPDU																																																																																			
P05	P05	00: Detected phase loss	○	●	○	ALT	Phase loss error / interruption of power supply	I/F																																																																																			
		01: Comp. 1 side 02: Comp. 2 side 03: Comp. 3 side					Inverter DC voltage (Vdc) error																																																																																				
P07	P07	01: Comp. 1 side 02: Comp. 2 side 03: Comp. 3 side	○	●	○	ALT	Heat sink overheat error	IPDU, I/F																																																																																			
P10	P10	Detected indoor address	●	○	○	ALT	Indoor overflow error	Indoor																																																																																			
P12	—	—	●	○	○	ALT	Indoor fan motor error or duct setting miss	Indoor																																																																																			
P13	P13	—	○	●	○	ALT	Outdoor liquid back detection error	I/F																																																																																			
P15	P15	01: TS condition 02: TD condition	○	●	○	ALT	Gas leak detection	I/F																																																																																			
P17	P17	—	○	○	○	ALT	Discharge temp. TD2 error	I/F																																																																																			

## SPECIAL INSTRUCTIONS—CONTROLS

Check code			Wireless remote control				Check code name	Judging device
Wired remote control display	Outdoor 7-segment display		Sensor block display of receiving unit					
	Auxiliary code		Operation	Timer	Ready	Flash		
P18	P18	—	○	●	○	ALT	Discharge temp. TD3 error	I/F
P19	P19	Detected outdoor unit number	○	●	○	ALT	4-way valve inverse error	I/F
P20	P20	—	○	●	○	ALT	High-pressure protective operation	I/F
P22	P22	0* : IGBT circuit 1* : Location detection circuit error 3* : Motor lock-up error 4* : Motor current was detected. C* : Abnormal temperature was detected by the TH sensor. D* : TH sensor error E* : Inverter DC voltage error (outdoor unit fan)  Caution) Although letters 0 to F appear at locations indicated by "*", please ignore them.	○	●	○	ALT	Outdoor fan IPDU error	IPDU
P26	P26	01: Comp. 1 side 02: Comp. 2 side 03: Comp. 3 side	○	●	○	ALT	G-TR short protection error	IPDU
P29	P29	01: Comp. 1 side 02: Comp. 2 side 03: Comp. 3 side	○	●	○	ALT	Comp position detective circuit system error	IPDU
P31	P31	—	○	●	○	ALT	Other indoor unit error (Group follower unit error)	Indoor

### Error detected by TCC-LINK central control device

Check code			Wireless remote control				Check code name	Judging device
Wired remote control display	Outdoor 7-segment display		Sensor block display of receiving unit					
	Auxiliary code		Operation	Timer	Ready	Flash		
C05	—	—	—	—	—	—	Sending error in TCC-LINK central control device	TCC-LINK
C06	—	—	—	—	—	—	Receiving error in TCC-LINK central control device	TCC-LINK
C12	—	—	—	—	—	—	Batch alarm of general-purpose equipment control interface	General-purpose equipment I/F
P30	Differs according to error contents of unit with occurrence of alarm						Group control branching unit error	TCC-LINK
	—	—	(L20 is displayed)				Duplicated central control addresses	

TCC-LINK: TOSHIBA Carrier Communication Link

## Warnings on refrigerant leakage

### Check of Concentration Limit

The room in which the air conditioner is to be installed requires a design that in the event of refrigerant gas leaking out, its concentration will not exceed a set limit. The refrigerant R410A which is used in the air conditioner is safe, without the toxicity or combustibility of ammonia, and is not restricted by laws to be imposed which protect the ozone layer. However, since it contains more than air, it poses the risk of suffocation if its concentration should rise excessively. Suffocation from leakage of R410A is almost non-existent. With the recent increase in the number of high concentration buildings, however, the installation of multi air conditioner systems is on the increase because of the need for effective use of floor space, individual control, energy conservation by curtailing heat and carrying power etc. Most importantly, the multi air conditioner system is able to replenish a large amount of refrigerant compared with conventional individual air conditioners. If a single unit of the multi conditioner system is to be installed in a small room, select a suitable model and installation procedure so that if the refrigerant accidentally leaks out, its concentration does not reach the limit (and in the event of an emergency, measures can be made before injury can occur). In a room where the concentration may exceed the limit, create an opening with adjacent rooms, or install mechanical ventilation combined with a gas leak detection device. The concentration is as given below.

$$\frac{\text{Total amount of refrigerant (lbs (kg))}}{\text{Min. volume of the indoor unit installed room (ft}^3 \text{ (m}^3\text{))}} \leq \text{Concentration limit (lbs/ft}^3 \text{ (kg/m}^3\text{))}$$

The concentration limit of R410A which is used in multi air conditioners is 0.019 lbs/ft<sup>3</sup> (0.3 kg/m<sup>3</sup>).

#### NOTE 1 :

If there are 2 or more refrigerating systems in a single refrigerating device, the amounts of refrigerant should be as charged in each independent device.

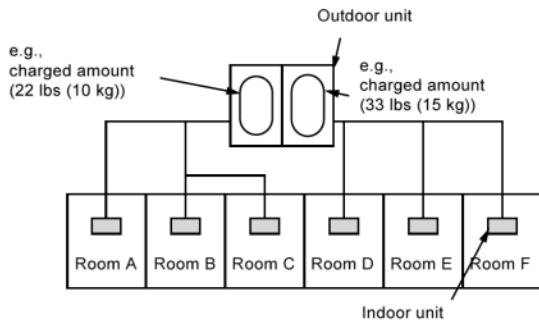

For the amount of charge in this example:  
 The possible amount of leaked refrigerant gas in rooms A, B and C is 22 lbs (10 kg).  
 The possible amount of leaked refrigerant gas in rooms D, E and F is 33 lbs (15 kg).

### Important

#### NOTE 2 :

The standards for minimum room volume are as follows.

- (1) No partition (shaded portion)

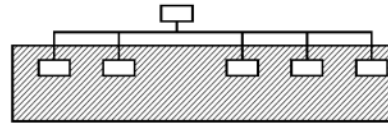

- (2) When there is an effective opening with the adjacent room for ventilation of leaking refrigerant gas (opening without a door, or an opening 0.15% or larger than the respective floor spaces at the top or bottom of the door).

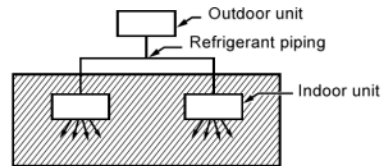

- (3) If an indoor unit is installed in each partitioned room and the refrigerant piping is interconnected, the smallest room of course becomes the object. But when a mechanical ventilation is installed interlocked with a gas leakage detector in the smallest room where the density limit is exceeded, the volume of the next smallest room becomes the object.

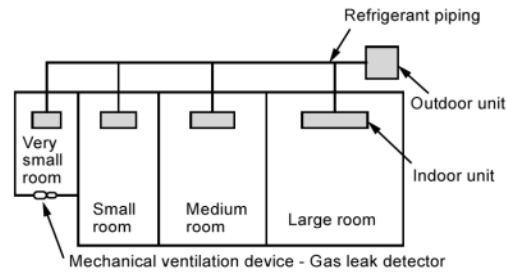

#### NOTE 3 :

The minimum indoor floor area compared with the amount of refrigerant is roughly as follows:  
 (When the ceiling is 8.9 ft (2.7 m) high)

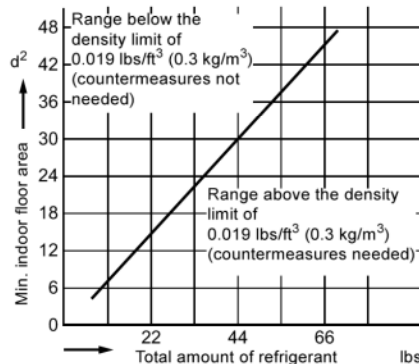

REPLACEMENT PARTS

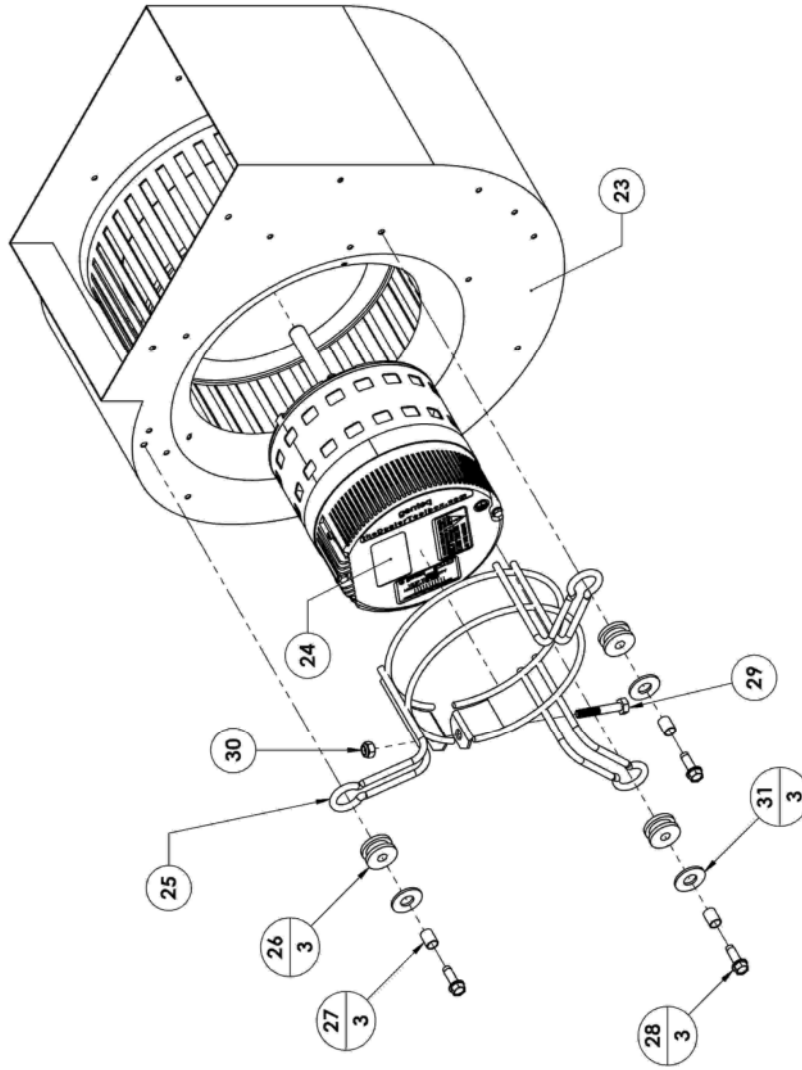

REF NO.	DESCRIPTION	PART NO								QTY
		MMD12	MMD18	MMD24	MMD30	MMD36	MMD42	MMD48	MMD60	
23	BLOWER ASSY (WHEEL AND HOUSING)	110-120019-001	110-120021-001	110-120021-001	110120000-000	110120000-000	103088R	103088R	110-120001-000	1
24	MOTOR	110-100006-000	110-100006-000	110-100006-000	110-100005-000	110-100005-000	110-100007-000	110-100007-000	110-100008-000	1
25	MTR MOUNT RING	110-180011-001	110-180011-001	110-180011-001	112036R	112036R	112036R	112036R	112036R	1
26	GROMMET, MOTOR				112169R					3
27	SPACER, MOTOR				111-900000-002					3
28	BOLT, MOTOR MOUNT				109721R					3
29	BOLT, MOTOR CLAMP				110-230028-000					1
30	FASTENER-NUT				109618R					1
31	WASHER, MOTOR				112230R					3

REPLACEMENT PARTS

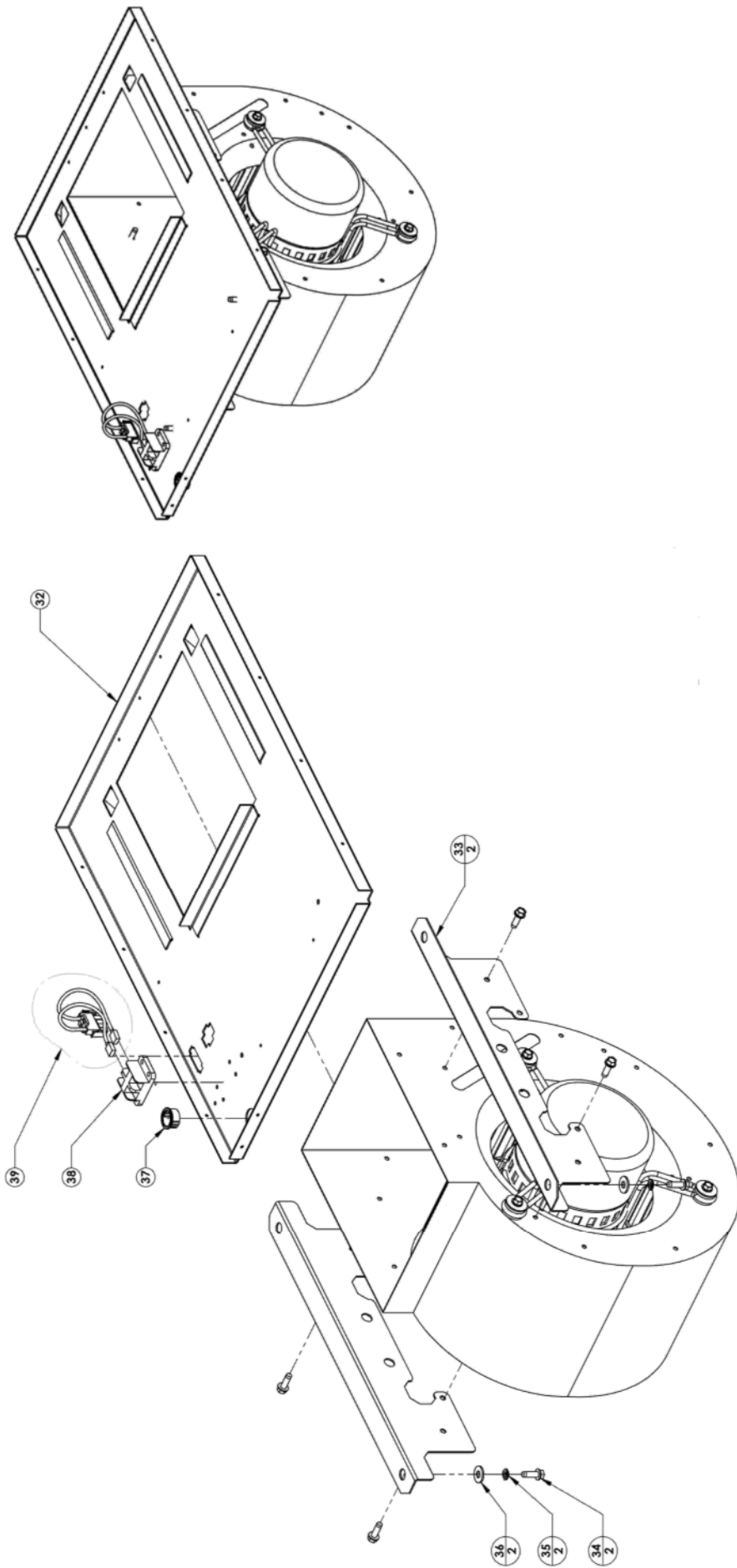

REF NO.	DESCRIPTION	PART NO								QTY
		MMD12	MMD18	MMD24	MMD30	MMD36	MMD42	MMD48	MMD60	
32	BLOWER DECK	176-006470-000	176-006203-000	176-006203-000	176-005920-000	176-005920-000	176-006204-000	176-006204-000	176-006205-000	1
33	BLOWER ANGLE	176-006212-000	176-006212-000	176-006212-000	176-006251-000	176-006251-000	176-006251-000	176-006251-000	176-006213-000	2
34	BOLT, BLOWER SUP				109721R					2
35	WASHER, LOCKING				109695R					2
36	WASHER, FLAT				109599R					2
37	SNAP BUSHING				112132R					1
38	TERMINAL BLOCK, L1L2				43160626					1
39	HARNES, POWER				112-000462-000					1

REPLACEMENT PARTS

REF NO.	DESCRIPTION	PART NO										QTY
		MMD12	MMD18	MMD24	MMD30	MMD36	MMD42	MMD48	MMD60			
40	FILTER RACK	173-571376-001	173-571376-001	173-571376-001	173-571377-001	173-571377-001	173-571378-001	173-571378-001	173-571378-001	173-571378-001	173-571379-001	1
41	DRAIN PAN SUPPORT	176-002851-000	176-002851-000	176-002851-000	176-002850-000	176-002850-000	176-002848-000	176-002848-000	176-002848-000	176-002848-000	176-002849-000	1
42	HEATER SUPPORT	176-006200-000	176-006200-000	176-006200-000	176-005919-000	176-005919-000	176-006201-000	176-006201-000	176-006201-000	176-006202-000	176-006202-000	1
43	HEATER SHIELD	176-006197-000	176-006197-000	176-006197-000	176-006253-000	176-006253-000	176-006198-000	176-006198-000	176-006198-000	176-006199-000	176-006199-000	1
44	HEATER BLOCKOFF	173-571474-001										1
45	COIL SUPPORT	176-006469-000	176-006218-000	176-006218-000	176-005923-000	176-005923-000	176-006219-000	176-006219-000	176-006219-000	176-006220-000	176-006220-000	1
46	COOLING COIL ASSEMBLY	375-002714-001	375-002698-001	375-002698-002	375-002693-001	375-002693-002	375-002699-001	375-002699-001	375-002699-001	375-002700-001	375-002700-001	1
47	DRAIN PAN, INSULATED	176-002644-000	176-002644-000	176-002644-000	176-002647-000	176-002647-000	176-002659-000	176-002659-000	176-002659-000	176-002656-000	176-002656-000	1
48	CAP PLUG, LIQUID TIGHT	112-000365-001										2
49	FIX PLATE SENSOR (4mm) (FOR TC1)	43107215										1
50	FIX PLATE SENSOR (6mm) (FOR TC, TC2)	43F19904										1
51	FIX PLATE SENSOR (6mm) (FOR TC1, TC2)	43F19904										1
52	FOAM TAPE	107280R										5
53	EXPANSION VALVE ASSEMBLY, RIGHT HAND DRAIN	375-003144-001	375-003082-001	375-003082-001	375-003082-001	375-003082-002	375-003082-002	375-003082-002	375-003082-002	375-003082-002	375-003082-002	1
54	SNAP PLUG	107711R										2
55	PANEL, TOP, INSULATED	176-003605-001	176-003605-001	176-003605-001	176-003606-001	176-003606-001	176-003607-001	176-003607-001	176-003607-001	176-003608-001	176-003608-001	1
56	SENSOR MOUNT	112-000509-001										1
57	SENSOR MOUNTING BRACKET	176-000972-000										1
58	FILTER	101750R	101750R	101750R	101752R	101752R	101754R	101754R	101754R	101756R	101756R	1
59	PANEL, COIL, RIGHT HAND DRAIN, RIGHT, INSULATED	176-005912-001	176-005912-001	176-005912-001	176-005913-001	176-005913-001	176-005914-001	176-005914-001	176-005914-001	176-005915-001	176-005915-001	1
60	PANEL, COIL, RIGHT HAND DRAIN, LEFT, INSULATED	176-005630-001	176-005630-001	176-005630-001	176-005631-001	176-005631-001	176-005632-001	176-005632-001	176-005632-001	176-005633-001	176-005633-001	1
61	FILTER DOOR	176-003073-001	176-003073-001	176-003073-001	176-003074-001	176-003074-001	176-003075-001	176-003075-001	176-003075-001	176-003076-001	176-003076-001	1
62	FILTER DOOR THUMB SCREW	112-000584-001										2
63	GROMMET, LIQUID LINE	112-000393-001	112398R	112398R	112398R	112398R	112398R	112398R	112398R	112398R	112398R	1
64	GROMMET, SUCTION LINE	112400R										1
65	PANEL, BLOWER ACCESS, INSULATED	176-005611-001	176-005611-001	176-005611-001	176-005613-001	176-005613-001	176-005615-001	176-005615-001	176-005615-001	176-005617-001	176-005617-001	1
66	COVER, ELECTRIC HEAT BREAKER	173-571495-001										1
	PMV (B25) 2.0mm	43146713 (Body), 43156707 (Motor)										1
	PMV (B40) 3.2mm	43146726 (Body), 43146707 (Motor)										1
	PMV (B60) 4.0mm	43146723 (Body), 43146707 (Motor)										1



# REPLACEMENT PARTS

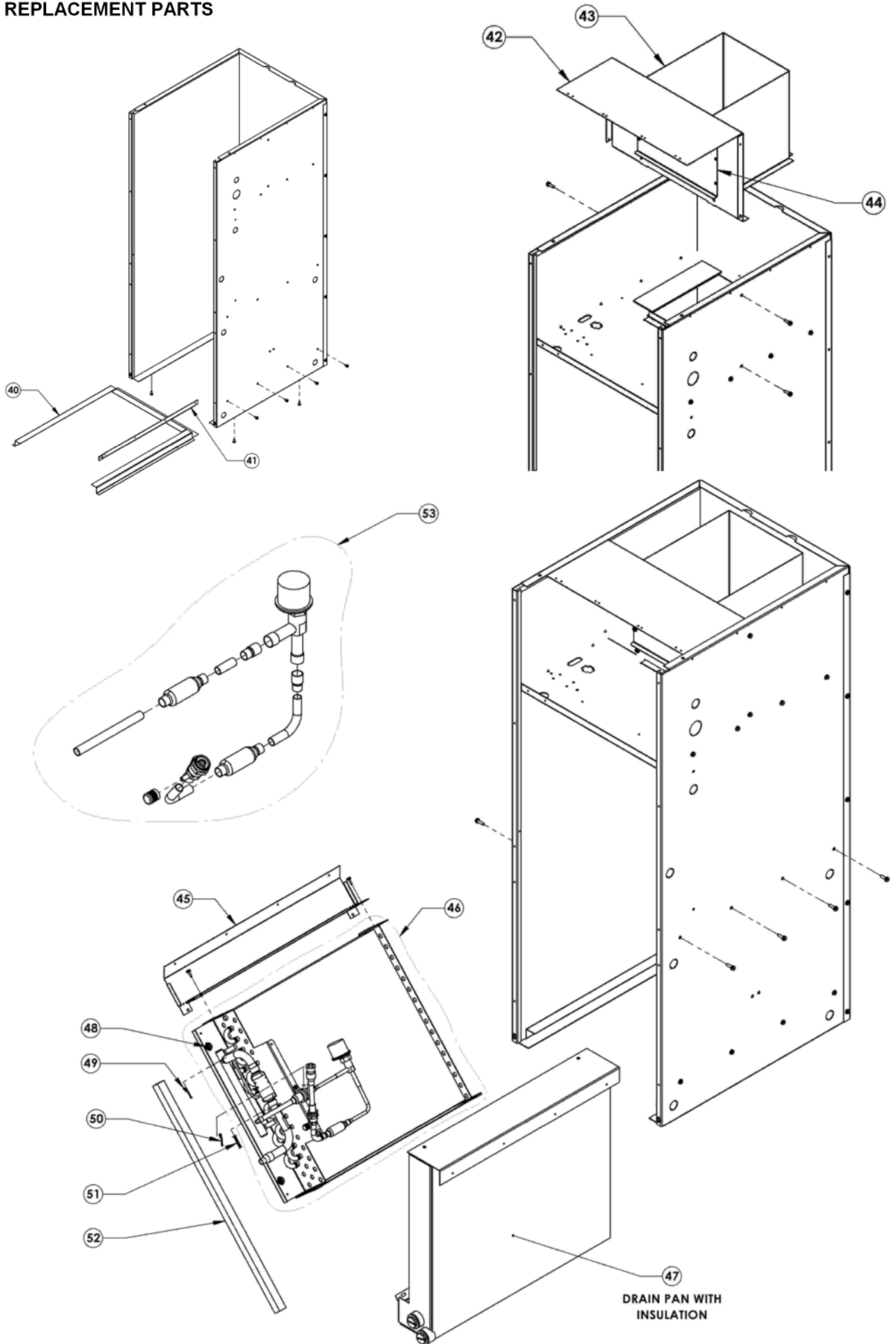

# REPLACEMENT PARTS

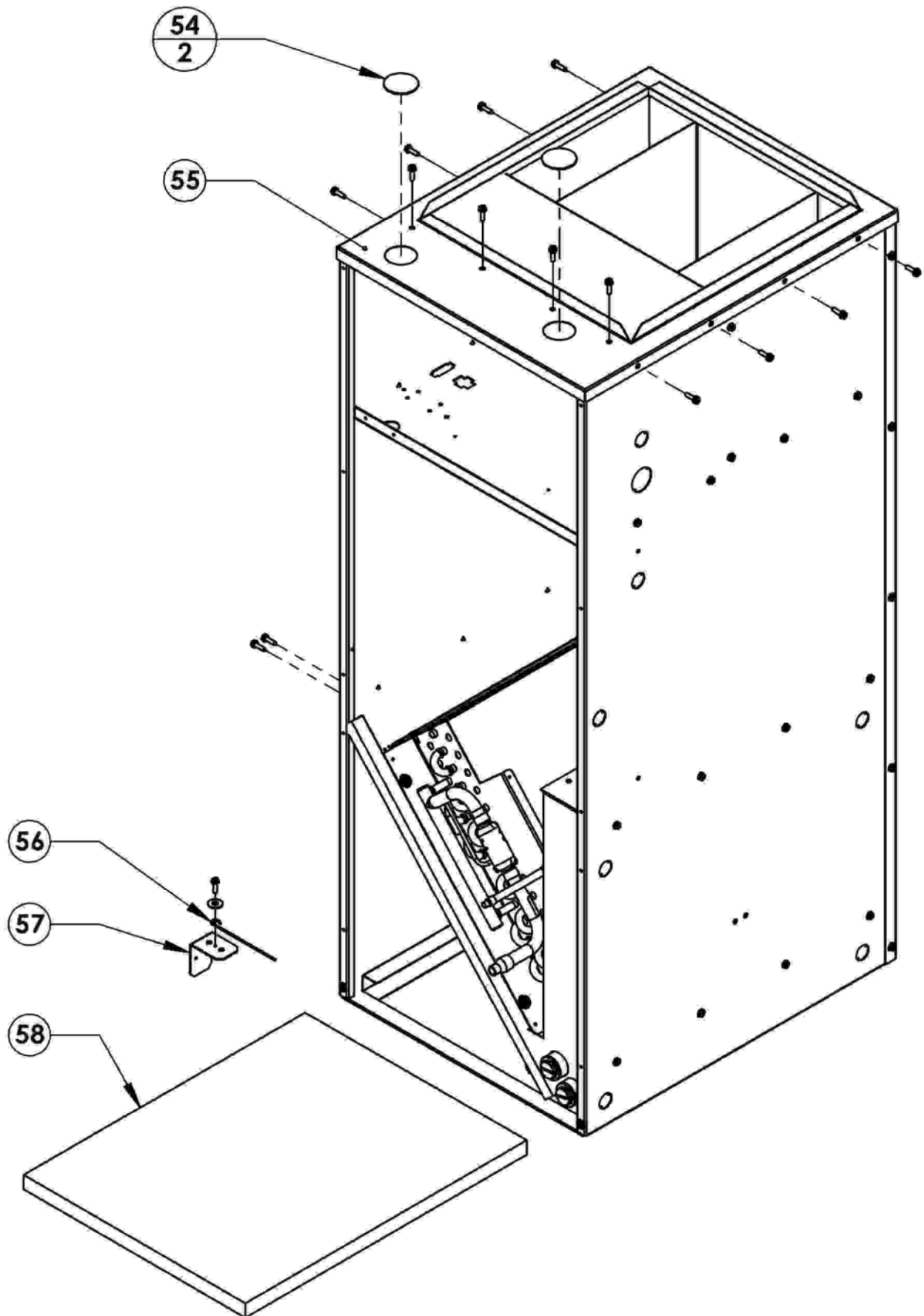

# REPLACEMENT PARTS

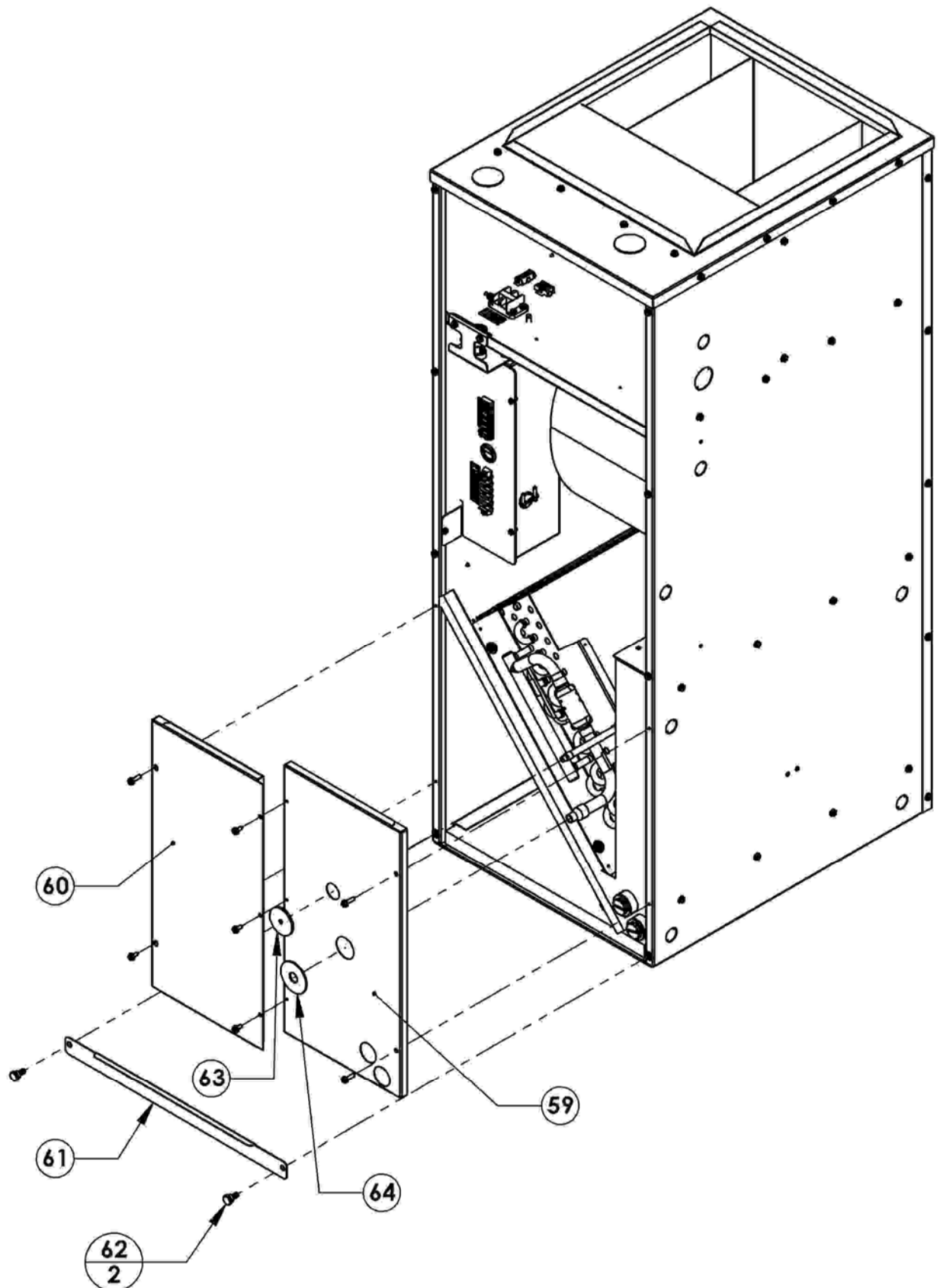

# REPLACEMENT PARTS

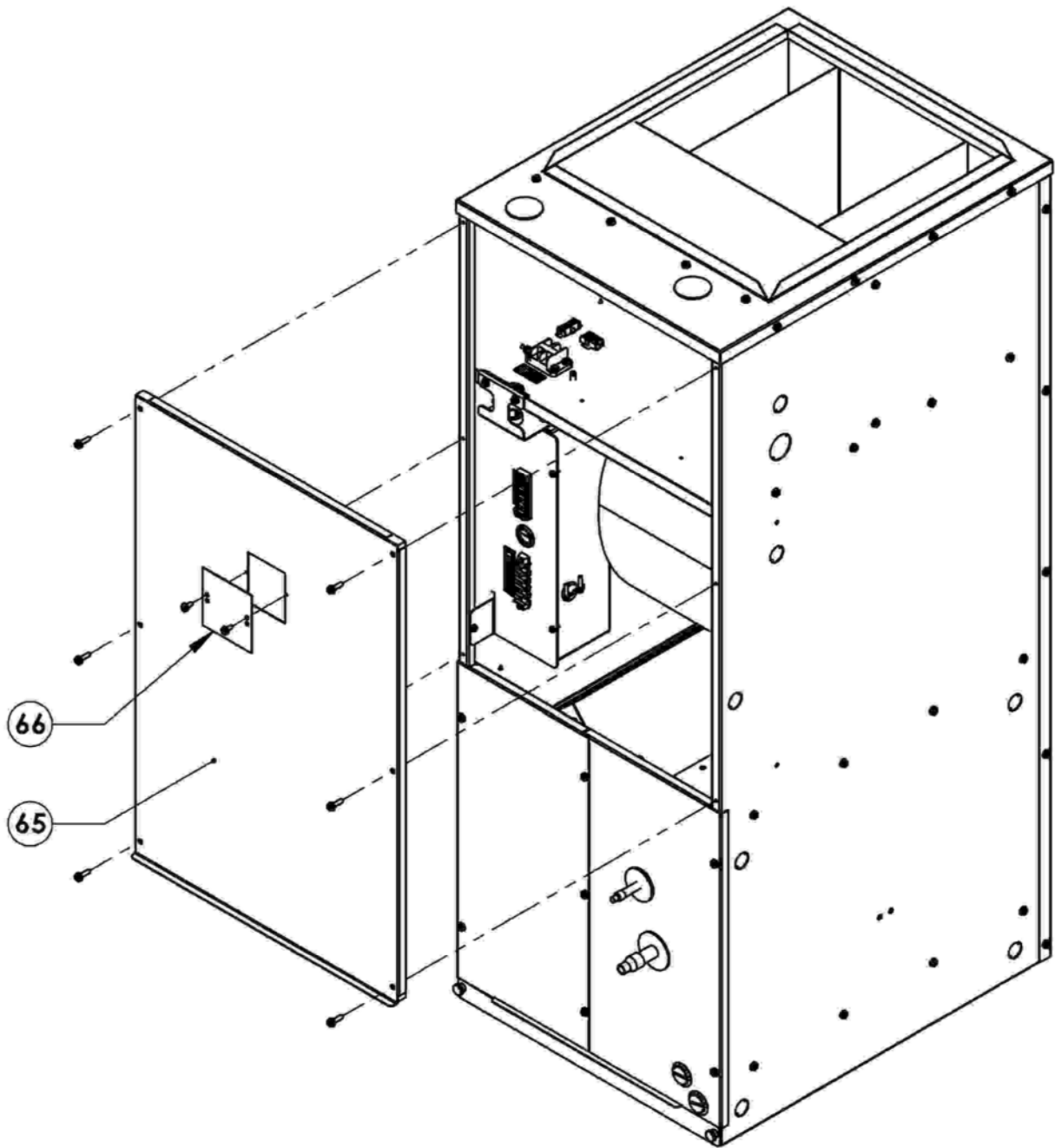

REPLACEMENT PARTS

REF NO.	DESCRIPTION	PART NO										QTY
		MMD12	MMD18	MMD24	MMD30	MMD36	MMD42	MMD48	MMD60			
1	CONTROL BOX				176-005775-000							1
2	CONTROL BOX COVER				176-005776-000							1
3	MOUNTING BRACKET				176-005917-000							1
4	CONTROL BOARD, MAIN				4316V634							1
5	CONTROL BOARD, DO				4316V338							1
6	TRANSFORMER				112158R							1
7	TERMINAL BLOCK, U1/U2/A/B				43160574							1
8	LABEL, TERMINAL BLOCK, U1/U2/A/B				EE87101101							1
9	TERMINAL BLOCK, 5P				112-000405-000							1
10	LABEL, TERMINAL BLOCK, 12345				110-200032-000							1
11	SNAP BUSHING				112132R							1
12	INSULATION				116-000689-001							1
13	GROMMET, SLITTED				107420R							1
14	THERMISTOR, TUBE, BLACK				43050425							1
15	THERMISTOR, TUBE, BLUE				43150320							1
16	THERMISTOR, TUBE, RED				43050425							1
17	THERMISTOR, BULB				43F50426							1
18	HARNESS, PMV				DH84209007							1
19	HARNESS, MTR PWR/CTRL				112-000389-000							1

# REPLACEMENT PARTS

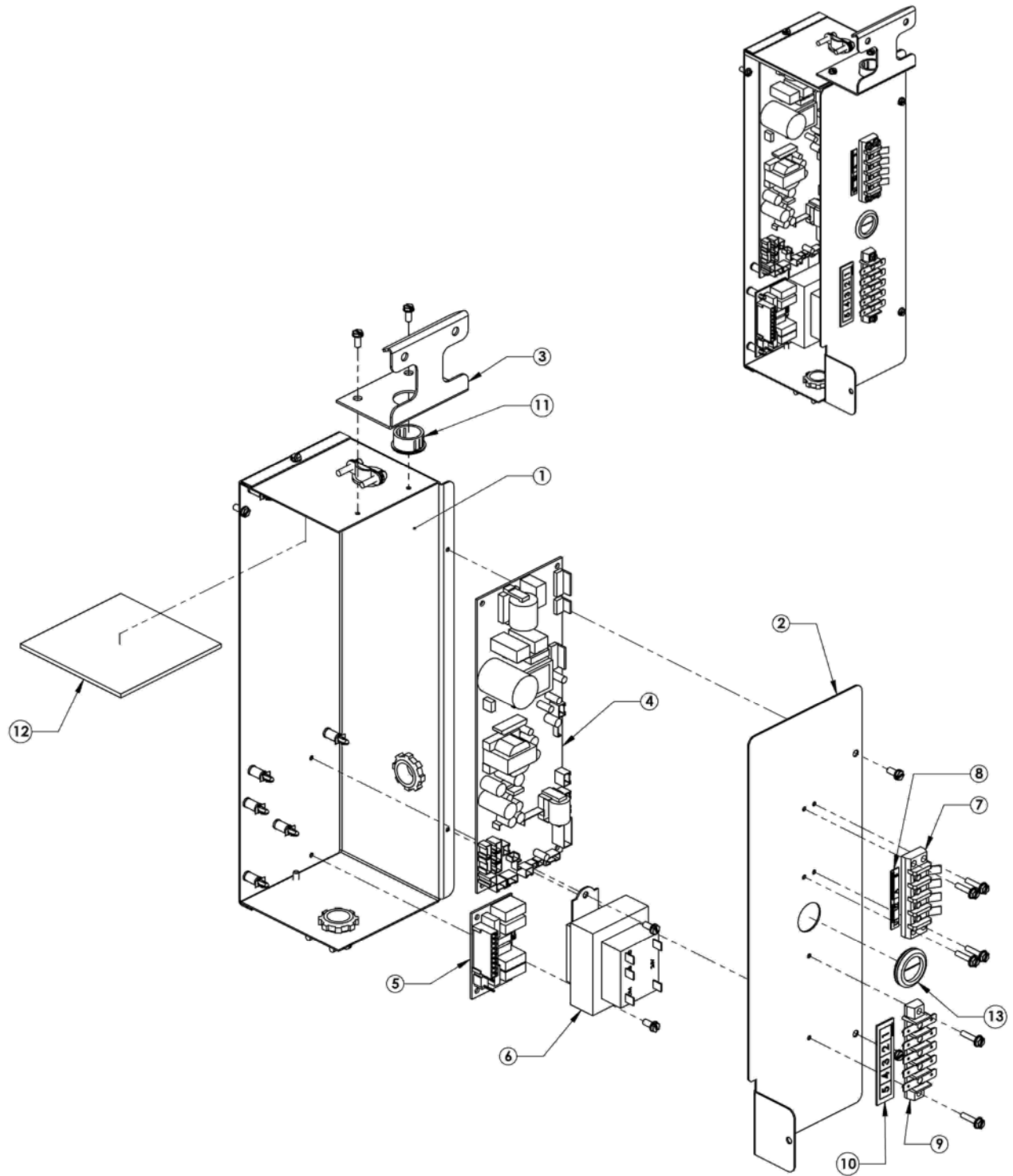

# REPLACEMENT PARTS

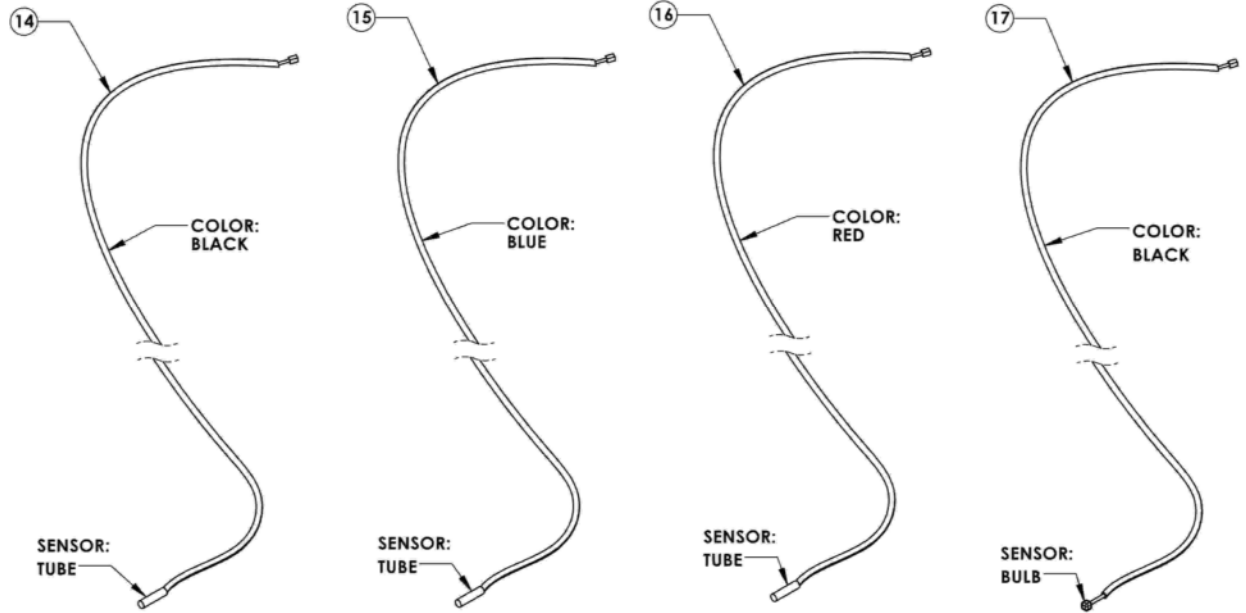

## MOTOR POWER / CONTROL HARNESS

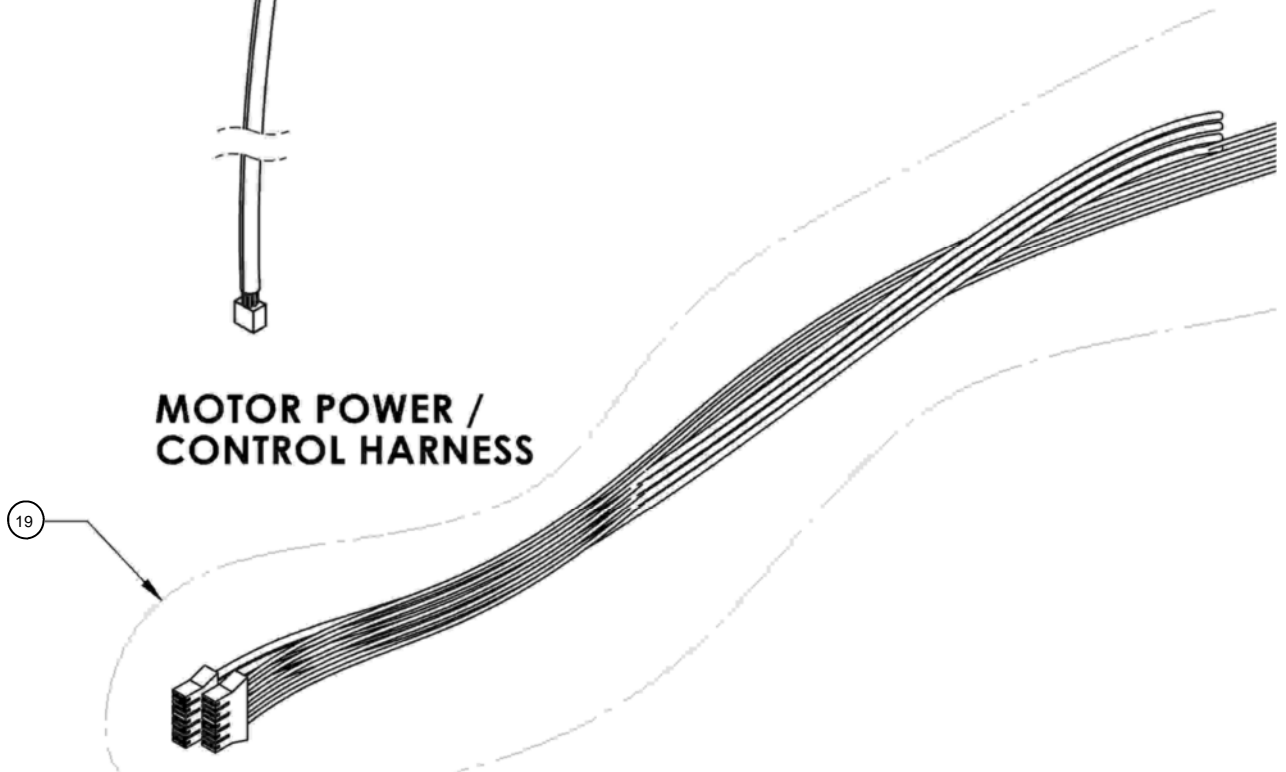

THIS PAGE INTENTIONALLY LEFT BLANK



# MMD Series Air Handling Unit

## Start-up Report

Job Name		City	
Sales Order #		Unit Tag	
Model Number		Serial Number	
Installer		Quantity of Units	

STARTUP REPORT			
Group	Checklist Item	Yes	No
Electrical/ Operational	Does electrical service correspond to unit nameplate?		
	-Nameplate Supply Voltage/Phase: Rated _____ Measured _____		
	-Nameplate Rated FLA motor current: Rated _____ Measured _____		
	Does all field wiring conform to unit wiring diagram?		
	Is field-provided freeze protection present? (if required)		
	Is fan wheel turning the correct direction?		
	Is the filter clean?		
Structural	Is unit properly supported?		
	Is unit installed level (necessary for proper condensate drainage)?		
	Is properly sized condensate trap present?		
	Is the condensate disposal system operating correctly?		
	Is auxiliary external condensate drain pan installed or auxiliary drain connection utilized as recommended by IOM? (not required for valid warranty)		
Piping Check	Is the DX system charged per the condensing unit instructions?		
	Is unit piping correct and insulated to prevent condensation?		
	Are the refrigerant pipe lines properly insulated?		
	Are there any leaks detected: interior to unit or at connections?		

THIS PAGE INTENTIONALLY LEFT BLANK

THIS PAGE INTENTIONALLY LEFT BLANK

**MMD Series Air Handling Unit**  
Installation, Operation and Maintenance Manual

