

Engineering Data Book



TABLE OF CONTENTS

4-WAY CASSETTE BASIC INFORMATION	3
Specifications.....	3
Accessories.....	7
PIPING DIAGRAM	8
DIMENSIONS	9
WIRING DIAGRAM	10
ELECTRICAL CHARACTERISTICS	12
AIR THROW CHARTS	13
SOUND DATA	21
Sound Pressure Levels.....	21
NC Curves.....	22
CAPACITY DATA TABLES	24

4-WAY CASSETTE BASIC INFORMATION

Specifications

Table 1 —Data Table

MODEL			40VMF009A--3	40VMF012A--3
Power Supply	V/Ph/Hz		208/230-1-60	
Total Cooling Capacity *1	Btu/h		9,000	12,000
Sensible Cooling Capacity *1	Btu/h		8,620	10,880
Heating Capacity *1	Btu/h		10,000	13,500
MCA	A		0.73	0.91
MOCP	A		15	
Panel / Grille			40VMF001----	
Dimensions of Unit (H x W x D)	in.		9 x 33-1/8 x 33-1/8	
Dimensions of Panel / Grille (H x W x D)	in.		1-3/4 x 37-3/8 x 37-3/8	
Net Unit Weight	lbs		54	
Net Panel / Grille Weight	lbs		13.2	
Filter	Dimensions L x H x D	in.	19-5/8 x 20-3-8 x 3/4	
	Qty		1 (Installed in Panel / Grille)	
Heat Exchanger			Inner Groove Copper Tube and Hydrophilic Aluminum fin	
Blower / Motor	Fan Type		Centrifugal	
	Motor Type		DC motor	
	Air Flow Rate (H/M/L)	CFM	460/390/330	560/460/390
	Sound Pressure Level (H/M/L)*2	dB(A)	36.7/34.0/32.1	41.4/37.3/33.0
	Motor Input	W	40	54
Min. External Static Pressure (Factory Setting)	in. WG		0	
Max. External Static Pressure	in. WG		0.12	
Piping Connections	Gas (Low) Pressure	in.	1/2	
	Liquid (High) Pressure	in.	1/4	
	Condensate	in.	1-1/4	
Condensate Lift	in.		29-1/2	
Refrigerant Control			Electronic Expansion Valve	
Connectable Outdoor Unit			38VMH – Heat Pump 38VMR – Heat Recovery 38VMH-1P – Single Phase Heat Pump	
Wiring	Power Wiring	AWG	Sized per NEC and Local Codes based on Nameplate Electrical Data	
	Control Wiring	AWG	2-core stranded shielded cable 18AWG	

NOTES:

*1 Rated per AHRI (Air Conditioning, Heating, and Refrigeration Institute) 1230 Standard

Cooling: Indoor 80°F (27°C) db / 67°F (20°C) wb; Outdoor 95°F (35°C) db

Heating: Indoor 70°F (21°C) db; Outdoor 47°F (8°C) db / 43°F (6°C) wb

*2 These values are measured in anechoic chamber at a distance of 4.6 feet below the unit.

Table 2 —Data Table

MODEL			40VMF015A--3	40VMF018A--3	
Power Supply		V/Ph/Hz	208/230-1-60		
Total Cooling Capacity *1		Btu/h	15,000	18,000	
Sensible Cooling Capacity *1		Btu/h	13,370	18,220	
Heating Capacity *1		Btu/h	17,000	21,000	
MCA		A	1.1	2.0	
MOCP		A	15		
Panel / Grille			40VMF001----		
Dimensions of Unit (H x W x D)		in.	9 x 33-1/8 x 33-1/8	11-3/4 x 33-1/8 x 33-1/8	
Dimensions of Panel / Grille (H x W x D)		in.	1-3/4 x 37-3/8 x 37-3/8		
Net Unit Weight		lbs	54.0	69.0	
Net Panel / Grille Weight		lbs	13.2		
Filter	Dimensions L x H x D		19-5/8 x 20-3-8 x 3/4		
	Qty		1 (Installed in Panel / Grille)		
Heat Exchanger			Inner Groove Copper Tube and Hydrophilic Aluminum fin		
Blower / Motor	Fan Type		Centrifugal		
	Motor Type		DC motor		
	Air Flow Rate (H/M/L)		CFM	680/560/460	1000/700/610
	Sound Pressure Level (H/M/L)*2		dBa	45.6/41.5/37.0	52.5/43.1/40.2
	Motor Input		W	67	153.5
Min. External Static Pressure (Factory Setting)		in. WG	0		
Max. External Static Pressure		in. WG	0.12		
Piping connections	Gas (Low) Pressure		in.	1/2	5/8
	Liquid (High) Pressure		in.	1/4	3/8
	Condensate		in.	1-1/4	
Condensate Lift		in.	29-1/2		
Refrigerant Control			Electronic Expansion Valve		
Connectable Outdoor Unit			38VMH – Heat Pump 38VMR – Heat Recovery 38VMH-1P – Single Phase Heat Pump		
Wiring	Power Wiring		AWG	Sized per NEC and Local Codes based on Nameplate Electrical Data	
	Control Wiring		AWG	2-core stranded shielded cable 18AWG	

NOTES:

*1 Rated per AHRI (Air Conditioning, Heating, and Refrigeration Institute) 1230 Standard
 Cooling: Indoor 80°F (27°C) db / 67°F (20°C) wb; Outdoor 95°F (35°C) db
 Heating: Indoor 70°F (21°C) db; Outdoor 47°F (8°C) db / 43°F (6°C) wb

*2 These values are measured in anechoic chamber at a distance of 4.6 feet below the unit.

Table 3 —Data Table

MODEL			40VMF024A--3	40VMF030A--3
Power Supply		V/Ph/Hz	208/230-1-60	
Total Cooling Capacity *1		Btu/h	24,000	30,000
Sensible Cooling Capacity *1		Btu/h	18,350	22,330
Heating Capacity *1		Btu/h	27,000	34,000
MCA		A	1.3	1.7
MOCP		A	15	
Panel / Grille			40VMF001----	
Dimensions of Unit (H x W x D)		in.	11-3/4 x 33-1/8 x 33-1/8	
Dimensions of Panel / Grille (H x W x D)		in.	1-3/4 x 37-3/8 x 37-3/8	
Net Unit Weight		lbs	69.0	
Net Panel / Grille Weight		lbs	13.2	
Filter	Dimensions L x H x D	in.	19-5/8 x 20-3-8 x 3/4	
	Qty		1 (Installed in Panel / Grille)	
Heat Exchanger			Inner Groove Copper Tube and Hydrophilic Aluminum fin	
Blower / Motor	Fan Type		Centrifugal	
	Motor Type		DC motor	
	Air Flow Rate (H/M/L)	CFM	800/700/610	950/800/680
	Sound Pressure Level (H/M/L)*2	dBA	44.7/42.5/40.2	49.5/45.1/42.1
	Motor Input	W	85.4	131.7
Min. External Static Pressure (Factory Setting)		in. WG	0	
Max. External Static Pressure		in. WG	0.12	
Piping connections	Gas (Low) Pressure	in.	5/8	
	Liquid (High) Pressure	in.	3/8	
	Condensate	in.	1-1/4	
Condensate Lift		in.	29-1/2	
Refrigerant Control			Electronic Expansion Valve	
Connectable Outdoor Unit			38VMH – Heat Pump 38VMR – Heat Recovery 38VMH-1P – Single Phase Heat Pump	
Wiring	Power Wiring	AWG	Sized per NEC and Local Codes based on Nameplate Electrical Data	
	Control Wiring	AWG	2-core stranded shielded cable 18AWG	

NOTES:

*1 Rated per AHRI (Air Conditioning, Heating, and Refrigeration Institute) 1230 Standard

Cooling: Indoor 80°F (27°C) db / 67°F (20°C) wb; Outdoor 95°F (35°C) db

Heating: Indoor 70°F (21°C) db; Outdoor 47°F (8°C) db / 43°F (6°C) wb

*2 These values are measured in anechoic chamber at a distance of 4.6 feet below the unit.

Table 4 —Data Table

MODEL			40VMF036A--3	40VMF048A--3
Power Supply		V/Ph/Hz	208/230-1-60	
Total Cooling Capacity *1		Btu/h	36,000	48,000
Sensible Cooling Capacity *1		Btu/h	26,240	32,390
Heating Capacity *1		Btu/h	40,000	54,000
MCA		A	2.3	2.4
MOCP		A	15	
Panel / Grille			40VMF001----	
Filter			Installed in Panel / Grille	
Dimensions of Unit (H x W x D)		in.	11-3/4 x 33-1/8 x 33-1/8	
Dimensions of Panel / Grille (H x W x D)		in.	1-3/4 x 37-3/8 x 37-3/8	
Net Unit Weight		lbs	69.0	
Net Panel / Grille Weight		lbs	13.2	
Filter	Dimensions L x H x D	in.	19-5/8 x 20-3-8 x 3/4	
	Qty		1 (Installed in Panel / Grille)	
Heat Exchanger			Inner Groove Copper Tube and Hydrophilic Aluminum fin	
Blower / Motor	Fan Type		Centrifugal	
	Motor Type		DC motor	
	Air Flow Rate (H/M/L)	CFM	1100/950/800	1200/1100/950
	Sound Pressure Level (H/M/L)*2	dBA	53.9/50.4/47.3	55.4/54.0/50.5
	Motor Input	W	182.7	202.3
Min. External Static Pressure (Factory Setting)		in. WG	0	
Max. External Static Pressure		in. WG	0.12	
Piping connections	Gas (Low) Pressure	in.	5/8	
	Liquid (High) Pressure	in.	3/8	
	Condensate	in.	1-1/4	
Condensate Lift		in.	29-1/2	
Refrigerant Control			Electronic Expansion Valve	
Connectable Outdoor Unit			38VMH – Heat Pump 38VMR – Heat Recovery 38VMH-1P – Single Phase Heat Pump	
Wiring	Power Wiring	AWG	Sized per NEC and Local Codes based on Nameplate Electrical Data	
	Control Wiring	AWG	2-core stranded shielded cable 18AWG	

NOTES:

*1 Rated per AHRI (Air Conditioning, Heating, and Refrigeration Institute) 1230 Standard













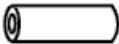

Cooling: Indoor 80°F (27°C) db / 67°F (20°C) wb; Outdoor 95°F (35°C) db

Heating: Indoor 70°F (21°C) db; Outdoor 47°F (8°C) db / 43°F (6°C) wb

*2 These values are measured in anechoic chamber at a distance of 4.6 feet below the unit.

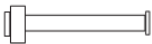
Accessories

Table 5 —Table of Accessories

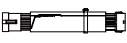
NAME	SHAPE	QUANTITY	FUNCTION
Nut		8	To connect the construction cover board to the fan motor
Washer		8	To connect the construction cover board to the fan motor
Construction cover board		1	Used to cover the fan motor
Bolt		4	To connect the construction cover board to the fan motor
Insulation		2	For covering the coil stub outs
Insulation		1	For covering the condensate drain
Clamp		1	For connecting the drain
Tie rope		5	For insulation
Condensate connection		1	For connecting drain
PQ connection wire		2	To connect outdoor unit, indoor unit, and sub MDC
Copper Nut		1	Connect piping
Flexible conduit and connectors		1	Routing power lines
Field wiring conduit assembly instruction		1	Guide for installing the conduit assembly
Connection Wire		1	For connecting occupancy sensor
Copper pipe for gas side		1	For connecting refrigerant pipe
Copper pipe for liquid side		1	For connecting refrigerant pipe
No Beep Harness		1	Prevent beeping noise

LEGEND:
MDC – Multiport Distribution Controller

PIPING DIAGRAM

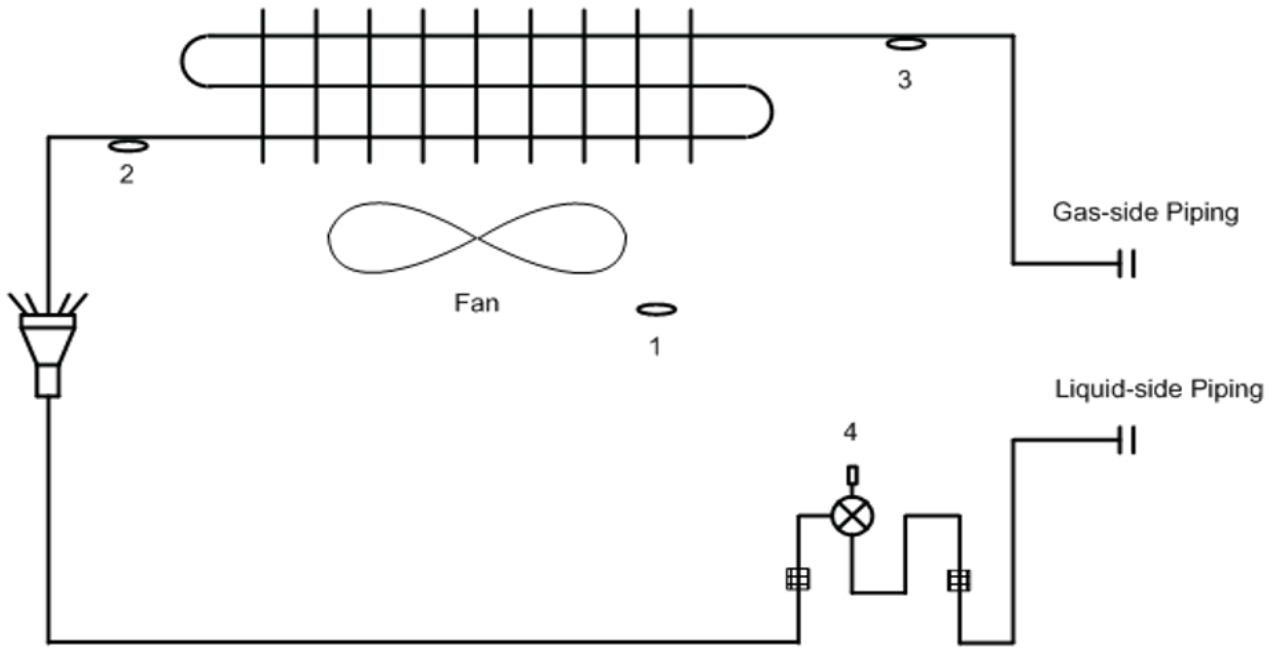

Fig. 1 —Piping

Table 6 —Piping

NUMBER	SYMBOL	NAME
1	T1	Room temperature sensor
2	T2A	Inlet pipe temperature sensor
3	T2B	Outlet pipe temperature sensor
4	EEV	Electronic expansion valve

Table 7 —Gas/Liquid Line Sizes

MODEL	GAS	LIQUID
40VMF009A/012A/015A--3	1/2	1/4
40VMF018A/024A/030A/036A/48A--3	5/8	3/8

DIMENSIONS

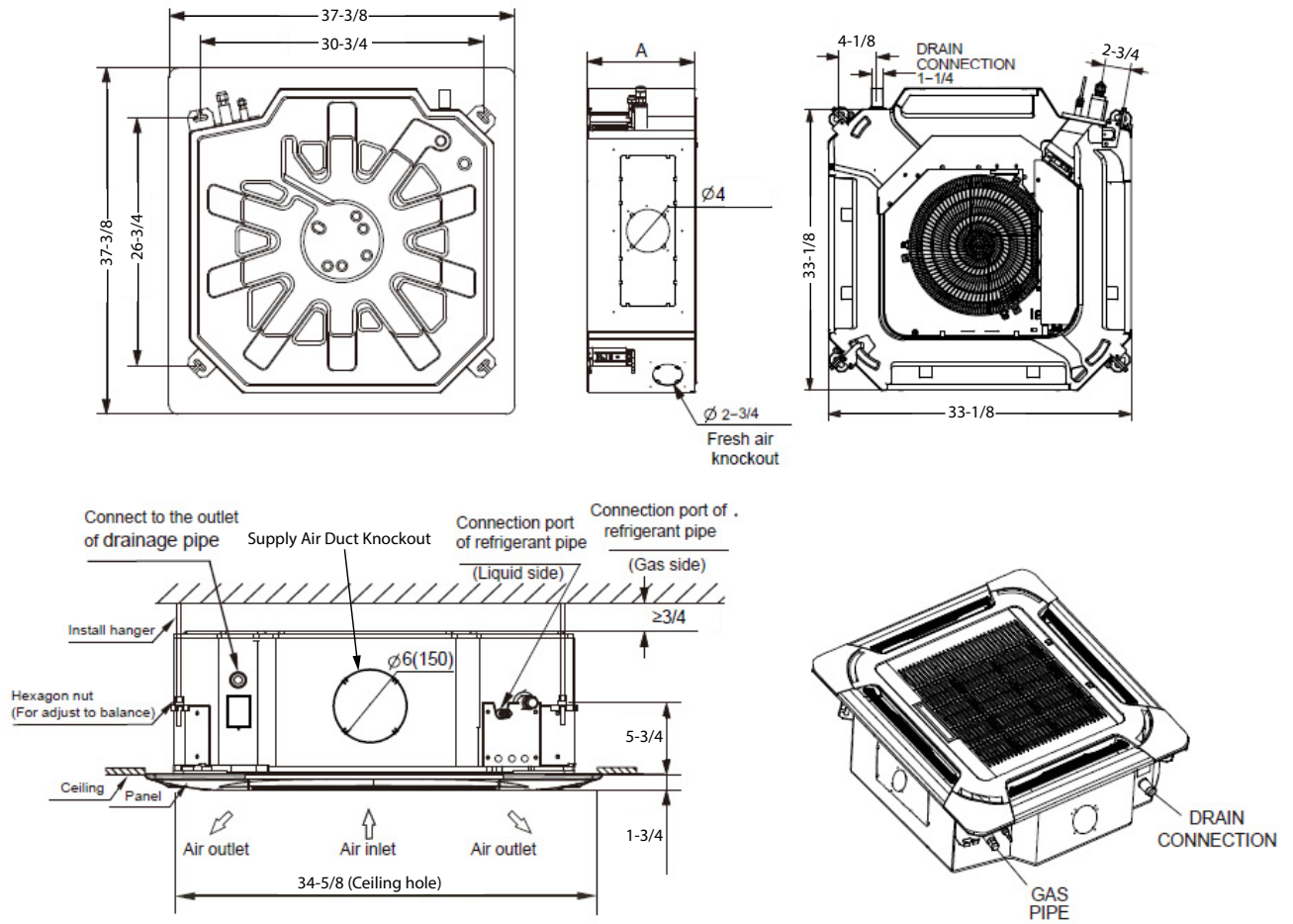

NOTE: All dimensions are shown in inches.

40VMF UNIT SIZE	DIMENSION A
009A	9
012A	
015A	
018A	11-3/4
024A	
030A	
036A	
048A	

Fig. 2 —40VMF009A--3 to 40VMF048A--3

WIRING DIAGRAM

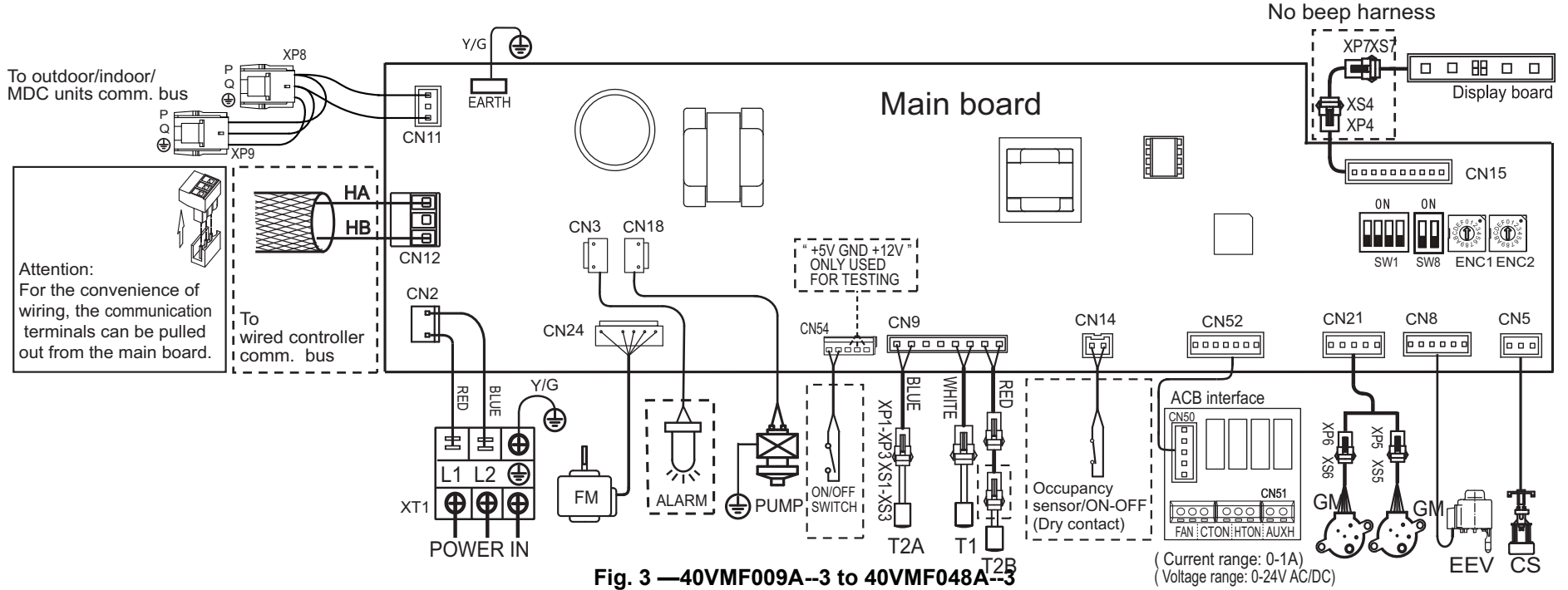

LEGEND:

ACB	—	Auxiliary Control Board AUXH	FM	—	Indoor Fan Motor	T1	—	Inlet Air Temperature
AUXH	—	Output For Auxiliary Heat	GM	—	Louver Motor	T2A	—	Coil Temperature
CS	—	Condensate Switch	HTON	—	Output for Heating Operation	T2B	—	Evap. Outlet Temperature in Cooling Mode
CTON	—	Output for Cooling Operation	MDC	—	Multiport Distribution Controller	XP1-9	—	Plug
EEV	—	Electronic Expansion Valve	PUMP	—	Pump Motor	XS1-9	—	Jack
FAN	—	DC Indoor Fan				XP-7/XS7	—	Connector

Wiring Diagram Definitions and Settings (40VMF009A--3 to 40VMF048A--3)

Table 8 —Code / Title

CODE	TITLE
FM	Indoor Fan Motor
T1	Room Temperature Sensor
T2A	Inlet Pipe Temperature Sensor
T2B	Outlet Pipe Temperature Sensor
ALARM	Warning Lamp
EEV	Electronic Extension Valve
XP1-8	Connectors
XS1-6	
XT1	Terminal
PUMP	Pump Motor
CS	Condensate Switch
GM	Swing Motor

Table 9 —ENC1 / ENC2



	Reserved		Reserved
---	----------	---	----------

Table 10 —SW8 Definition



	Reserved
	Reserved

Table 11 —SW1 Definition





	0 means auto addressing mode (Default)
	1 means factory test mode
	0 means normal mode (Default)
	1 means factory self-checking mode (Reserved)
	Reserved
	0 means standard indoor unit (Default)
	1 means main indoor unit (must be addressed #63)

Table 12 —0/1 Definition

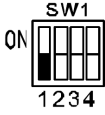
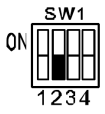
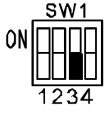
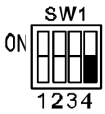

	Means 0
	Means 1

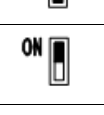
Table 13 —Error Code / Content

dd	Heating / Cooling Conflict
E1	Communication Error with Outdoor Unit
E2	Temperature Sensor (T1) Error
E4	Temperature Sensor (T2B) Error
E5	Temperature Sensor (T2A) Error
E6	DC Fan Error
E7	EEPROM Error (Data Storage)
UU	MDC Error in Auto System-Check Mode
E9	Communication Error with Wired Controller
Eb	EEV Error
EC	Indoor Fan Error in Auto System-Check Mode
Ed	Outdoor Unit Error
EE	Condensate Error
FE	No Address when Powered On for the First Time

ELECTRICAL CHARACTERISTICS

Table 14 —Electrical Characteristics

MODEL	POWER SUPPLY				IFM		
	Hz	VOLTS	VOLTAGE RANGE	MCA	MOCP	W	FLA
40VMF009A--3	60	208/230V	Max.253V Min.187V	0.73	15	80	0.59
40VMF012A--3				0.91	15	80	0.72
40VMF015A--3				1.1	15	170	0.81
40VMF018A--3				2.0	15	170	1.60
40VMF024A--3				1.3	15	170	0.98
40VMF030A--3				1.7	15	170	1.40
40VMF036A--3				2.3	15	170	1.80
40VMF048A--3				2.4	15	170	2.00

MCA: Minimum Circuit Amps (A)

MOCP: Maximum Over Current Protection (A)

SYMBOLS: W: Fan Motor Rated Output (W)

FLA: Full Load Amps (A)

IFM: Indoor Fan Motor

AIR THROW CHARTS

40VMF009A--3

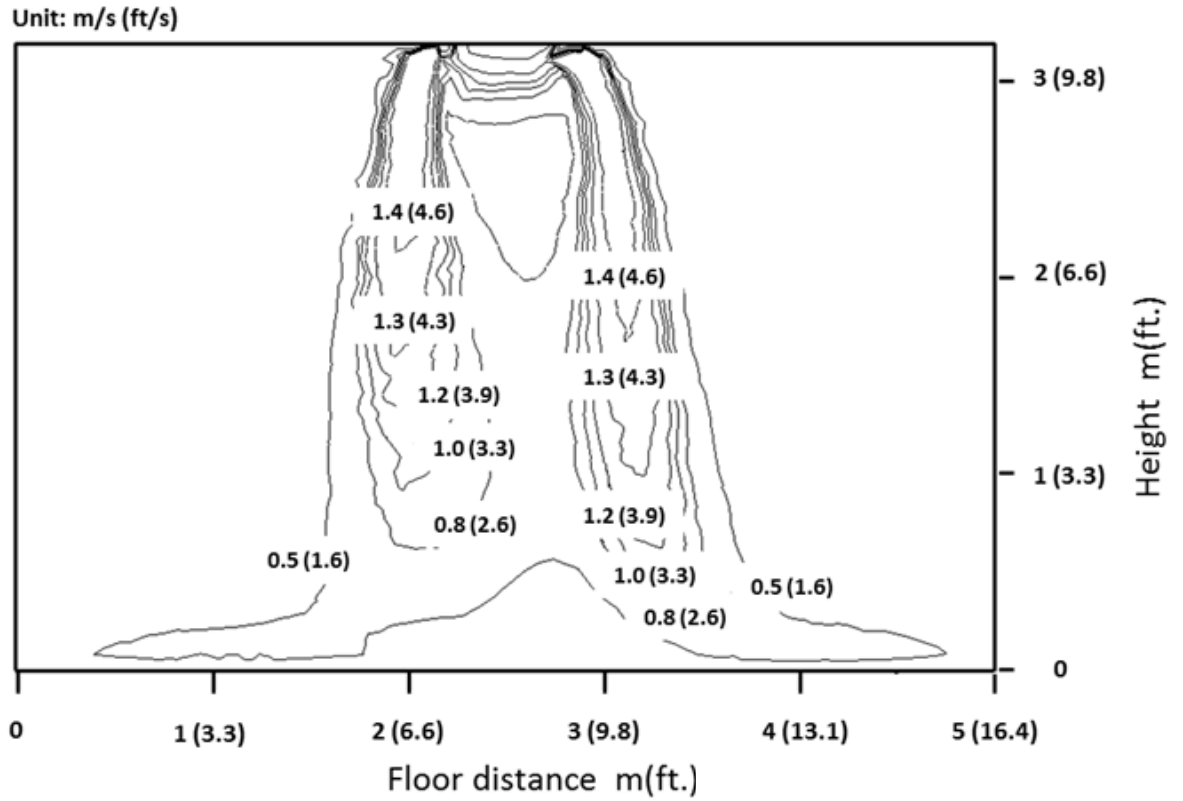

Fig. 4 —Cooling Velocity

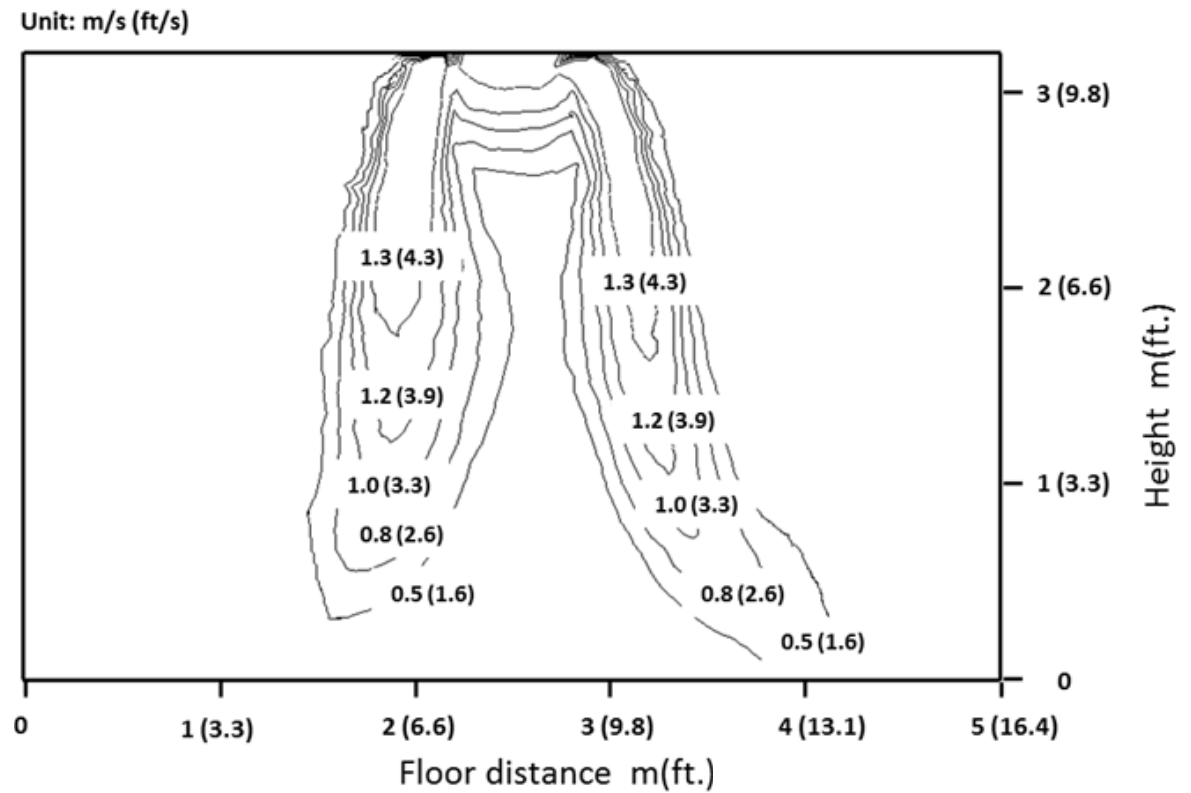

Fig. 5 —Heating Velocity

Unit: m/s (ft/s)

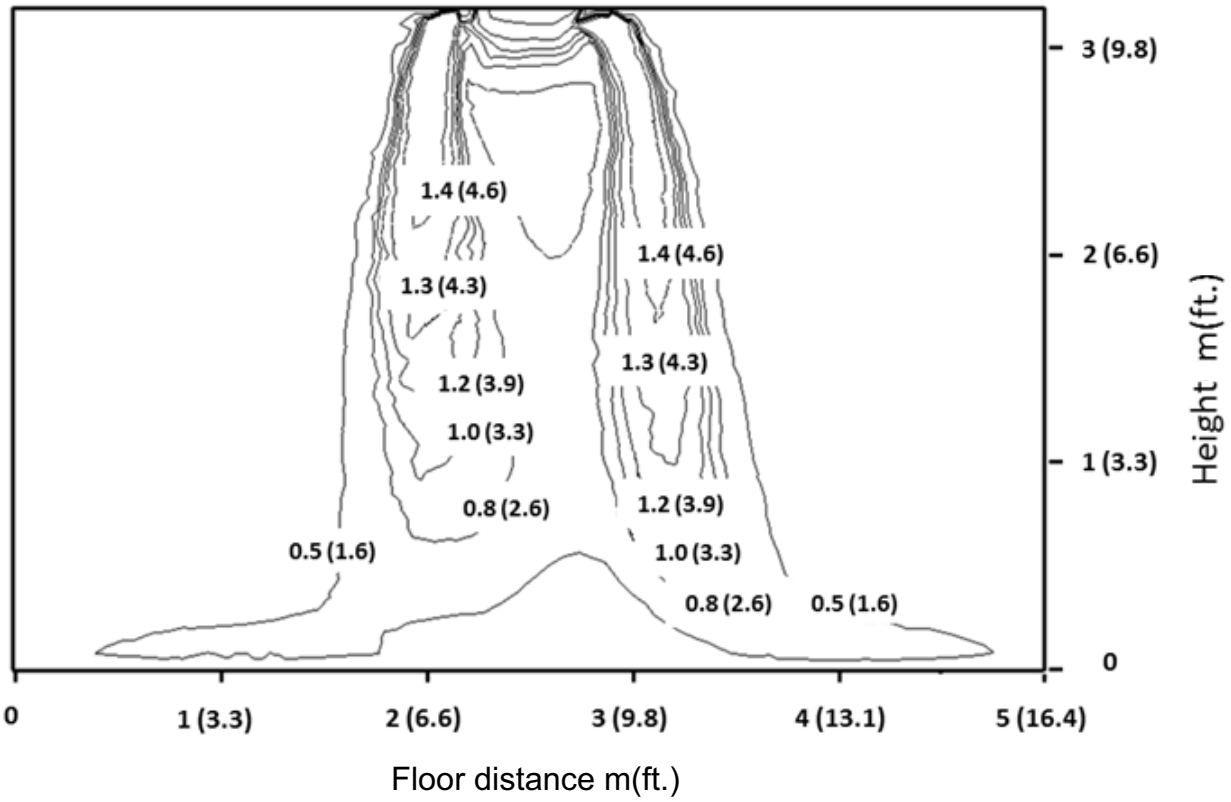

Fig. 6 —Cooling mode with 60°swing

Unit: m/s (ft/s)

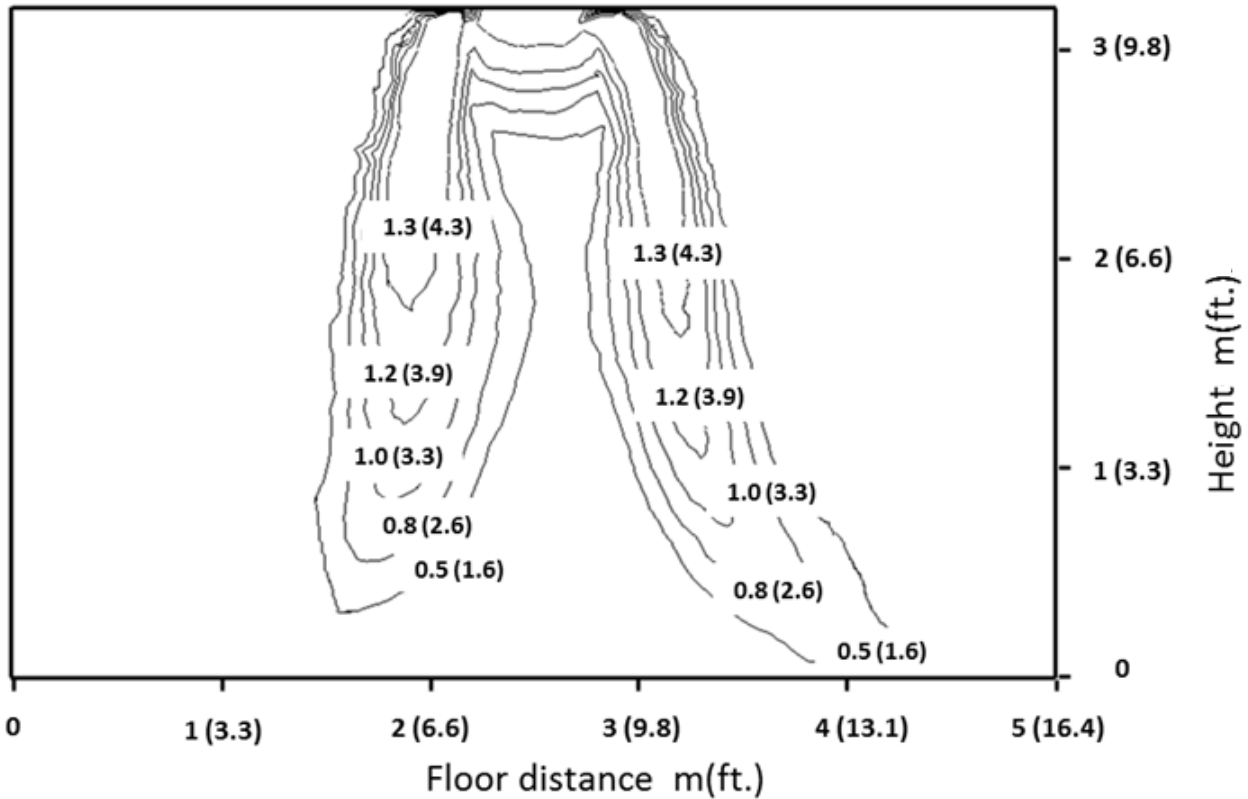

Fig. 7 —Heating mode with 60°swing

Unit: m/s (ft/s)

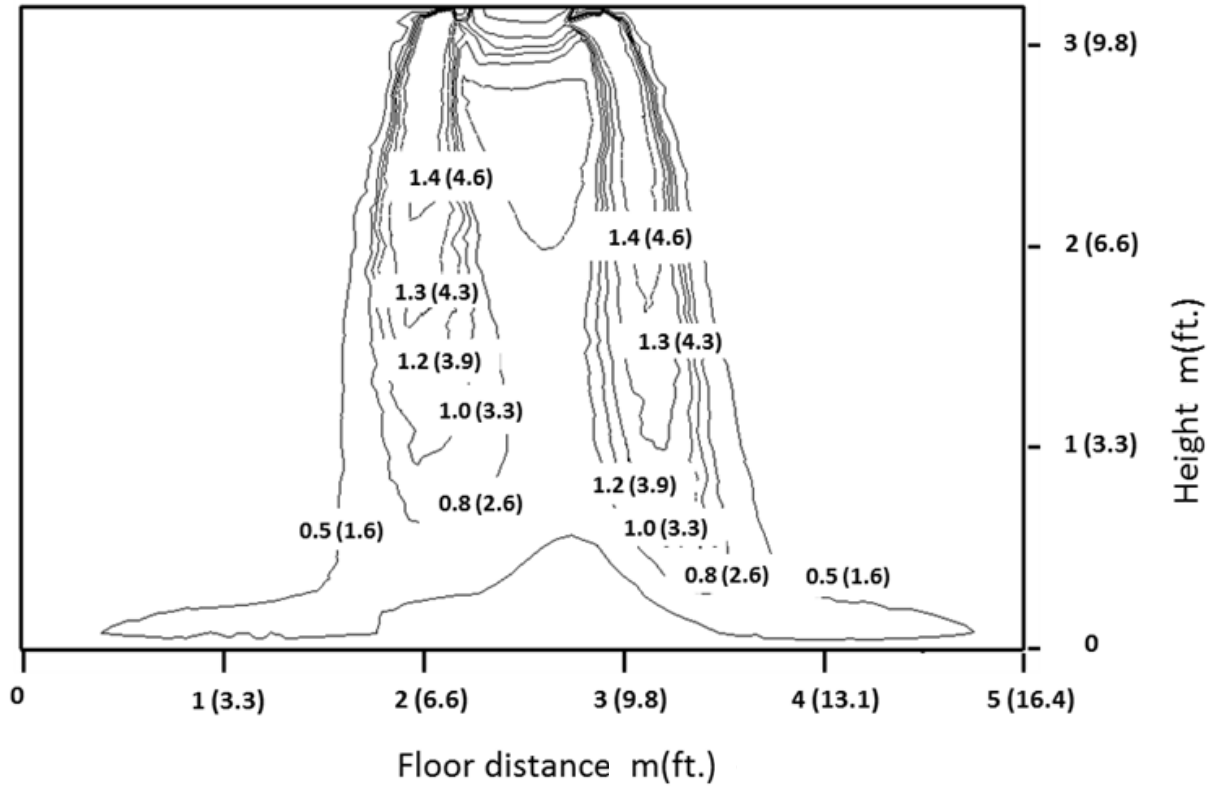

Fig. 8 —Cooling mode with 60°swing

Unit: m/s (ft/s)

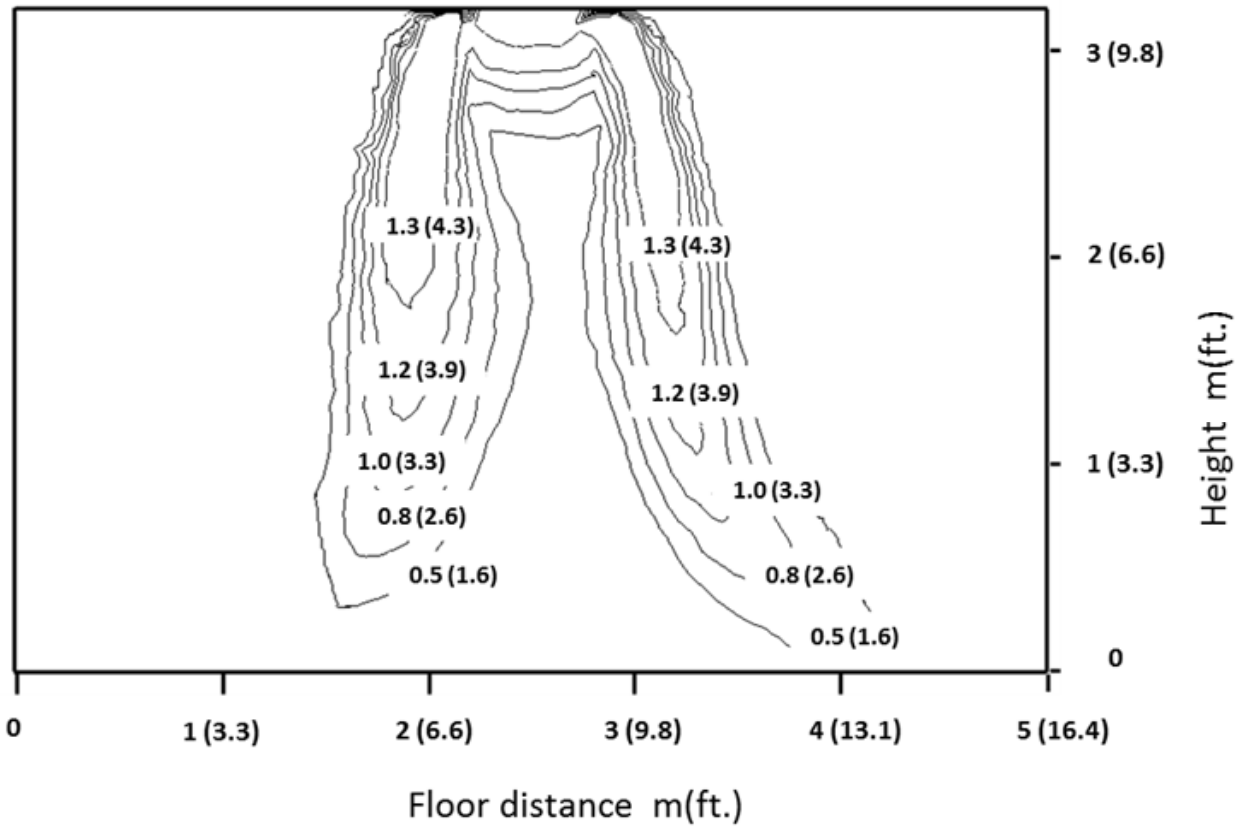

Fig. 9 —Heating mode with 60°swing

Unit: m/s (ft/s)

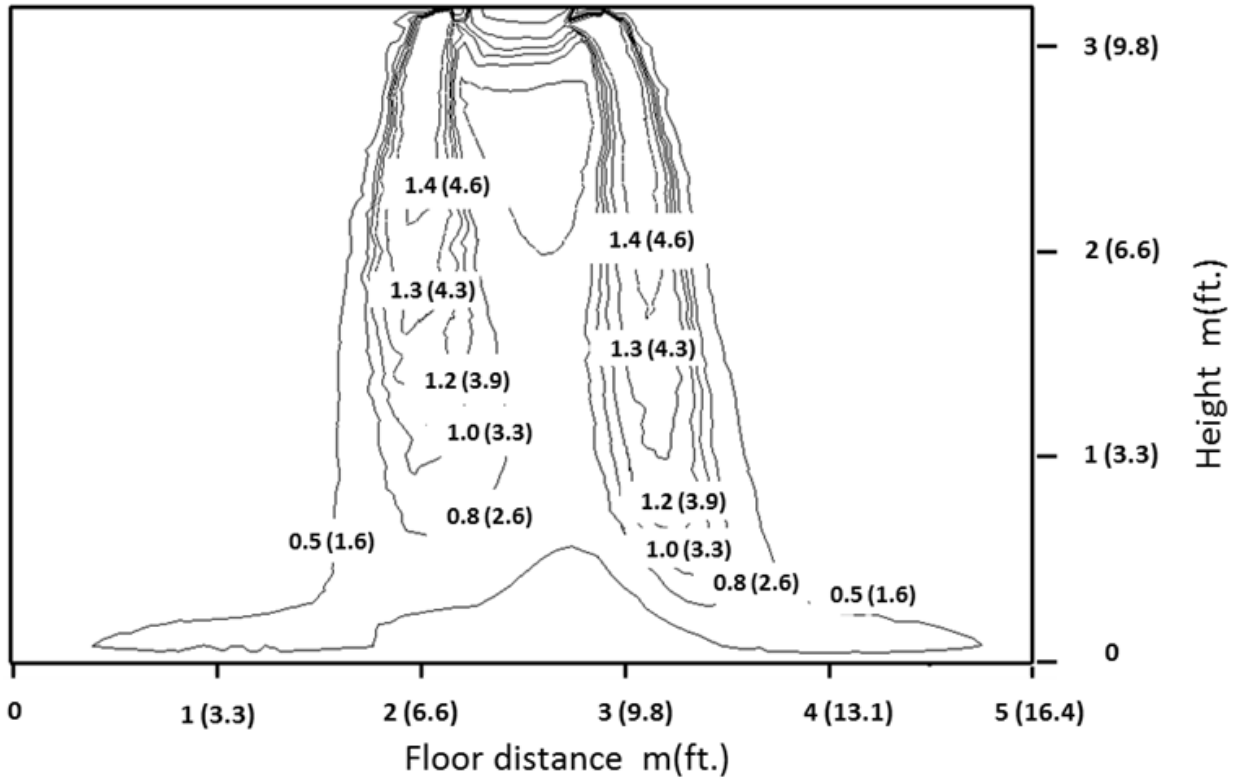

Fig. 10 —Cooling mode with 60°swing

Unit: m/s (ft/s)

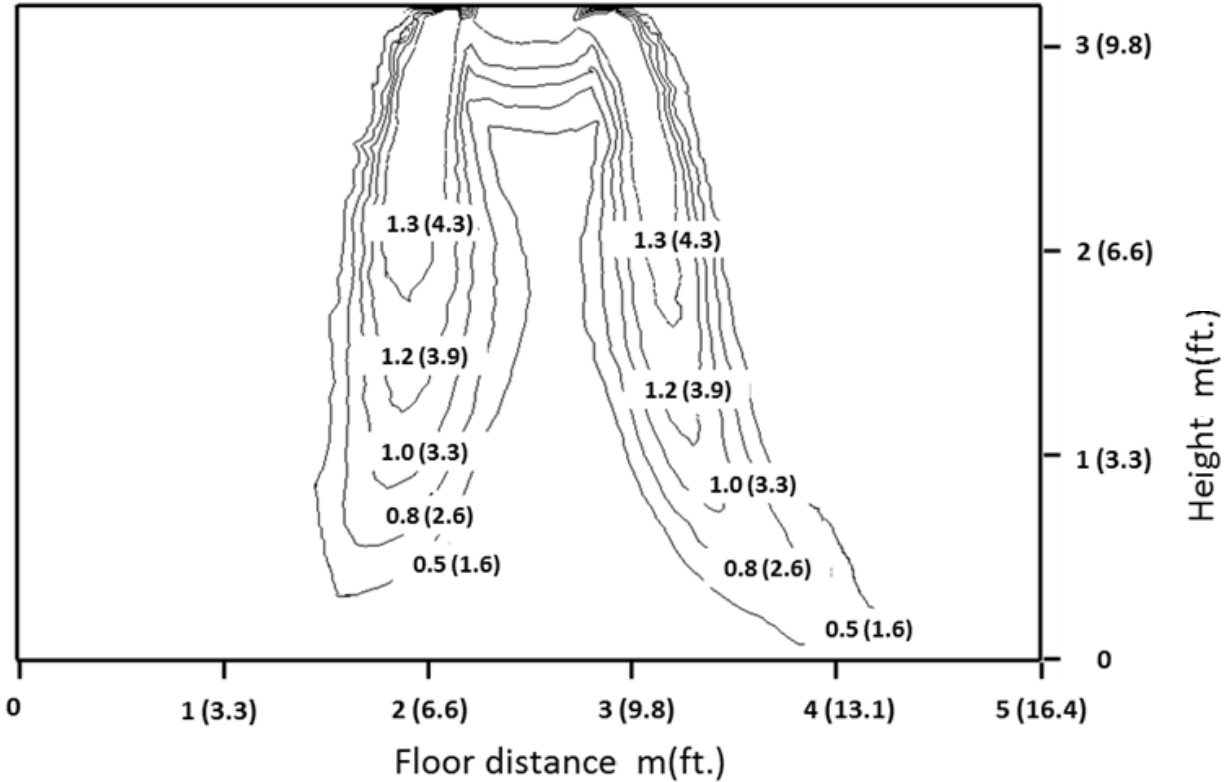

Fig. 11 —Heating mode with 60°swing

Unit: m/s (ft/s)

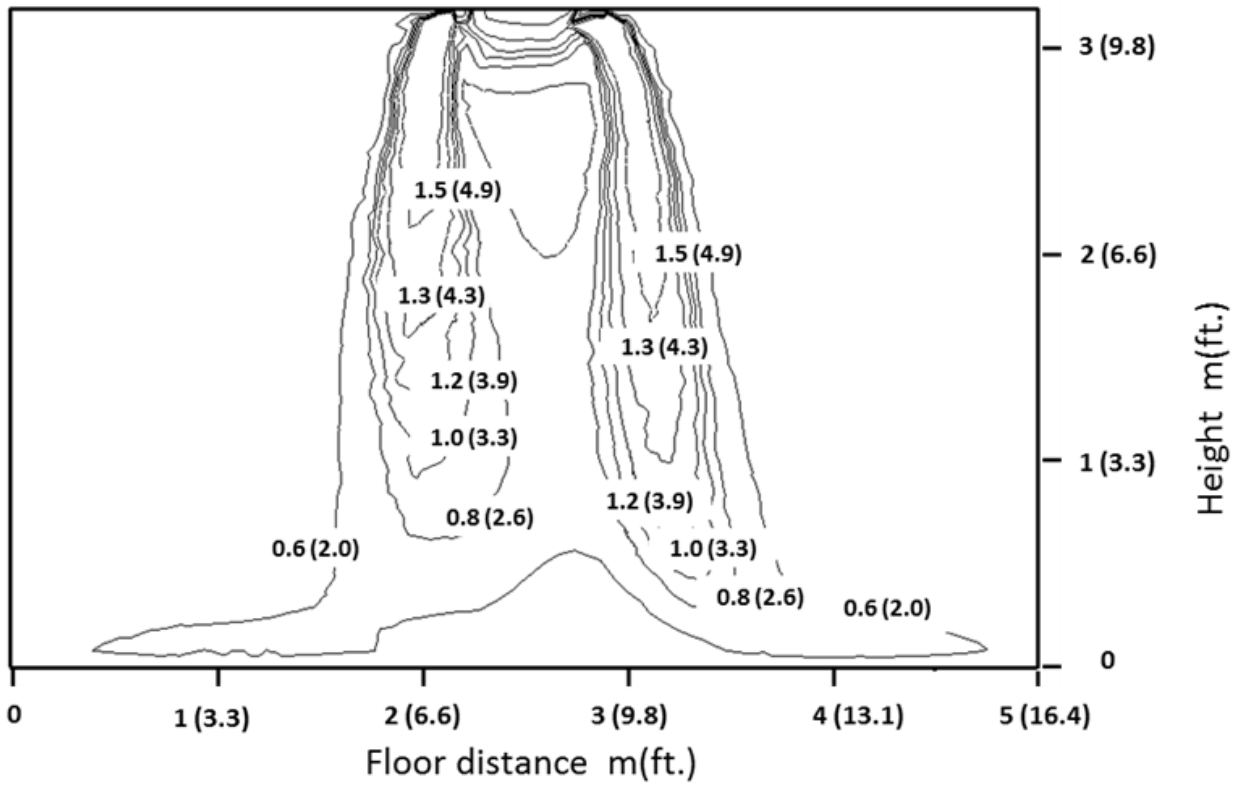

Fig. 12 —Cooling mode with 60°swing

Unit: m/s (ft/s)

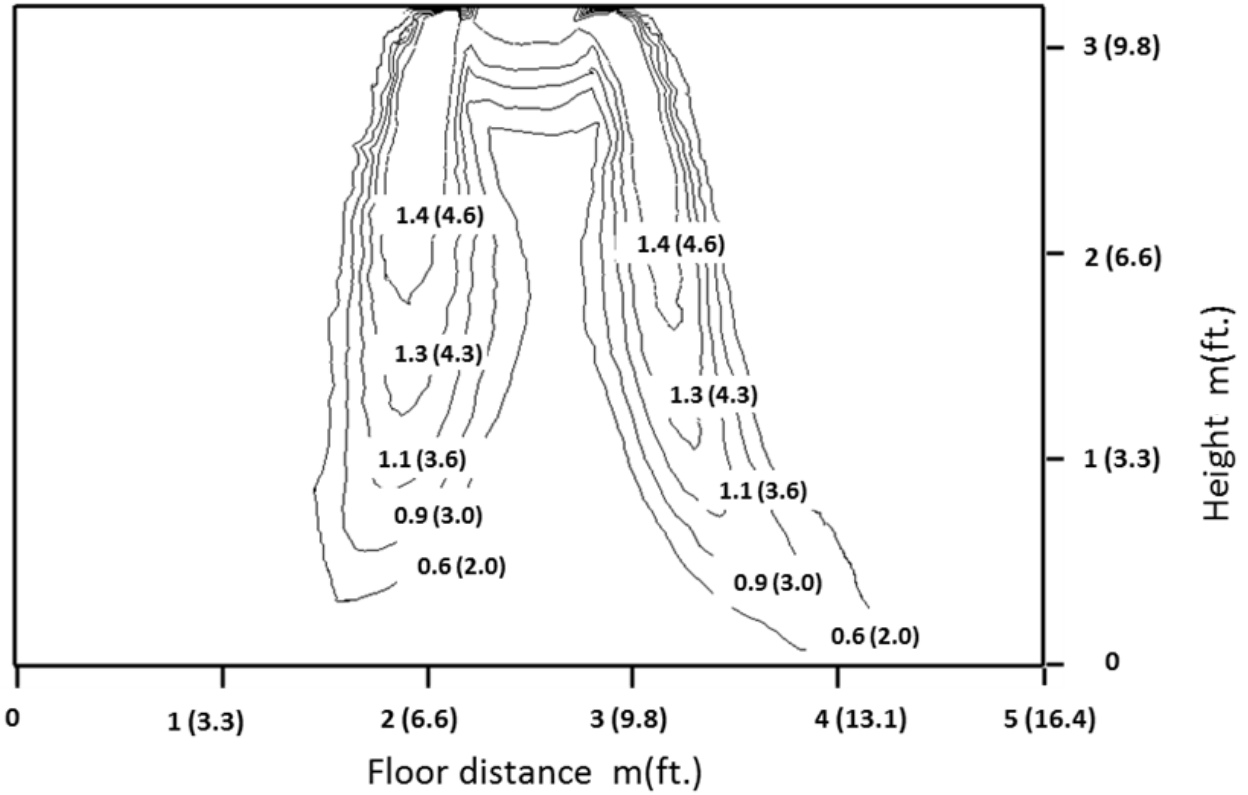

Fig. 13 —Heating mode with 60°swing

Unit: m/s (ft/s)

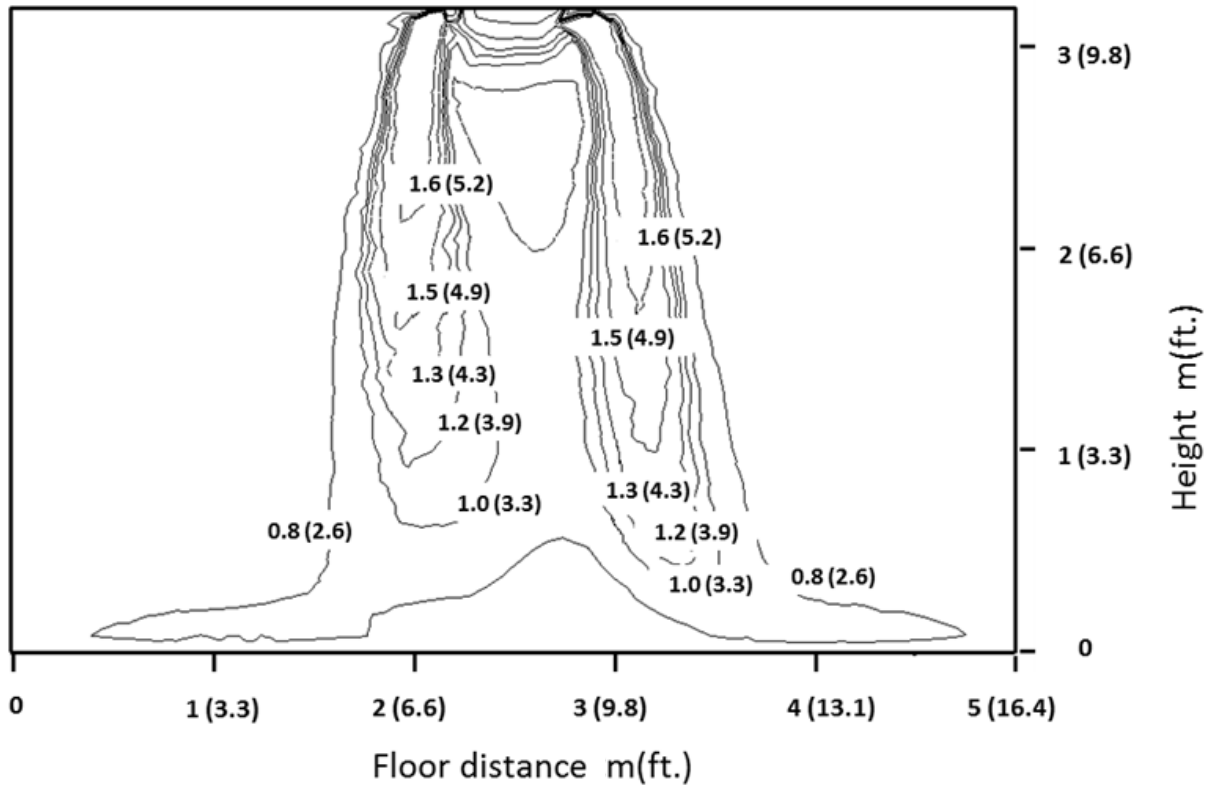

Fig. 14 —Cooling mode with 60°swing

Unit: m/s (ft/s)

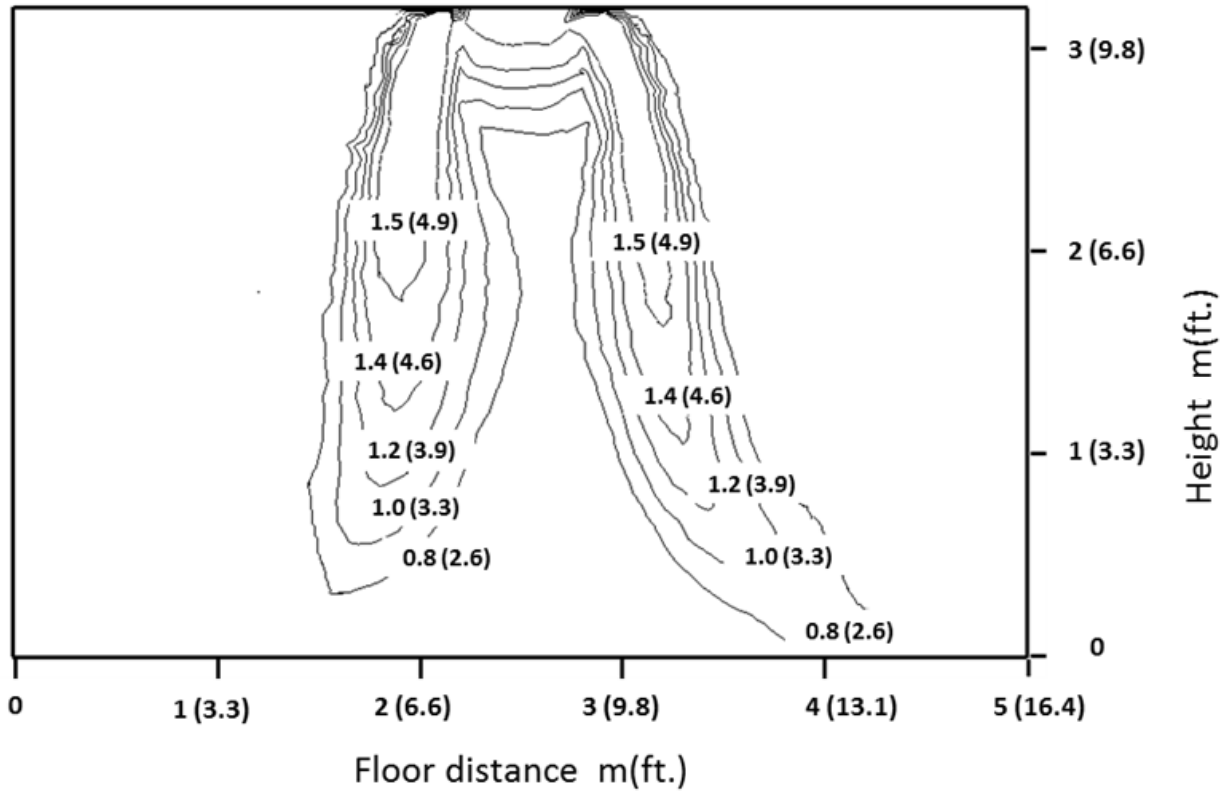

Fig. 15 —Heating mode with 60°swing

Unit: m/s (ft/s)

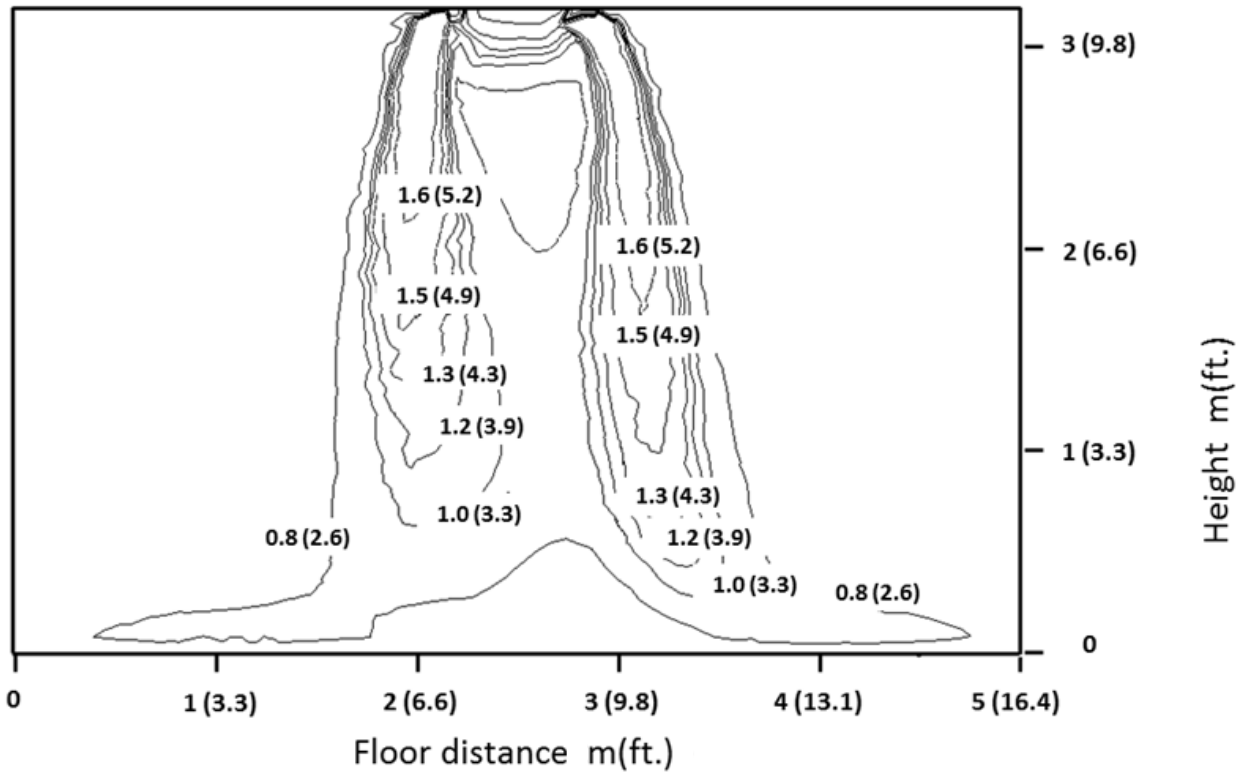

Fig. 16 —Cooling mode with 60°swing

Unit: m/s (ft/s)

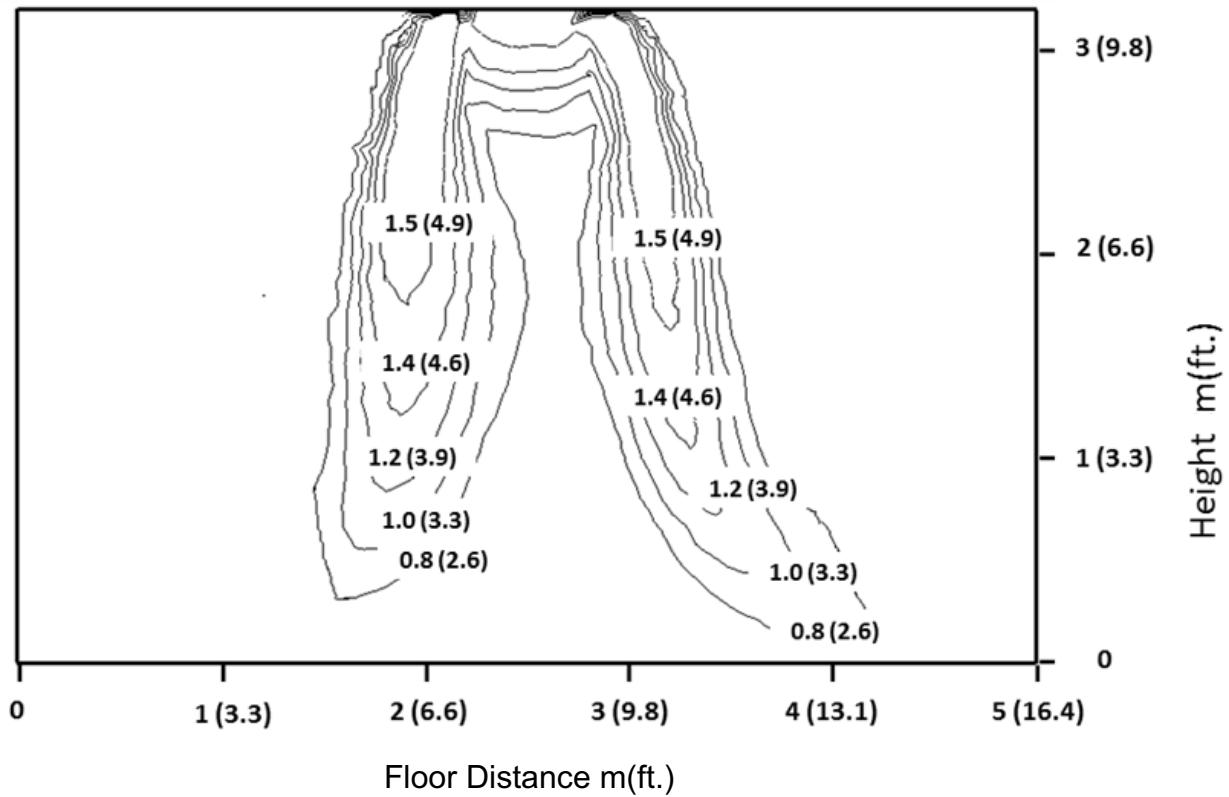

Fig. 17 —Heating mode with 60°swing

Unit: m/s (ft/s)

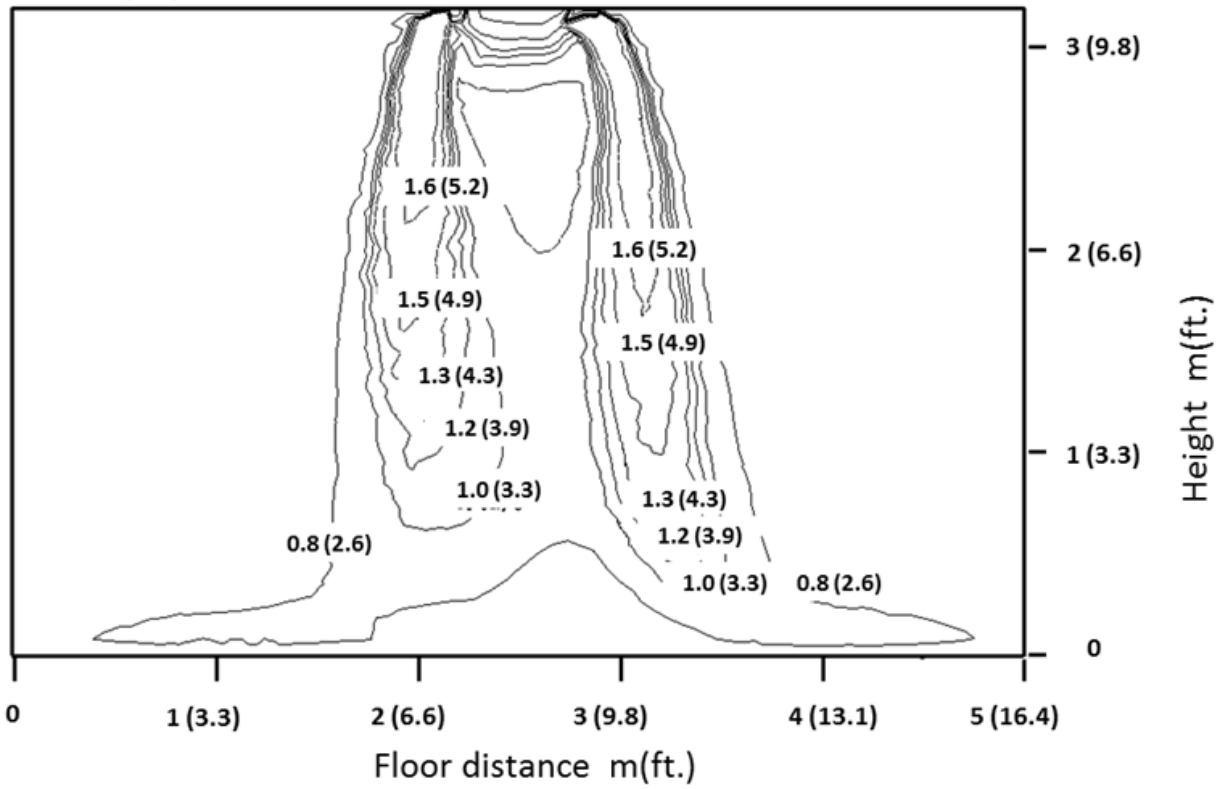

Fig. 18 —Cooling mode with 60°swing

Unit: m/s (ft/s)

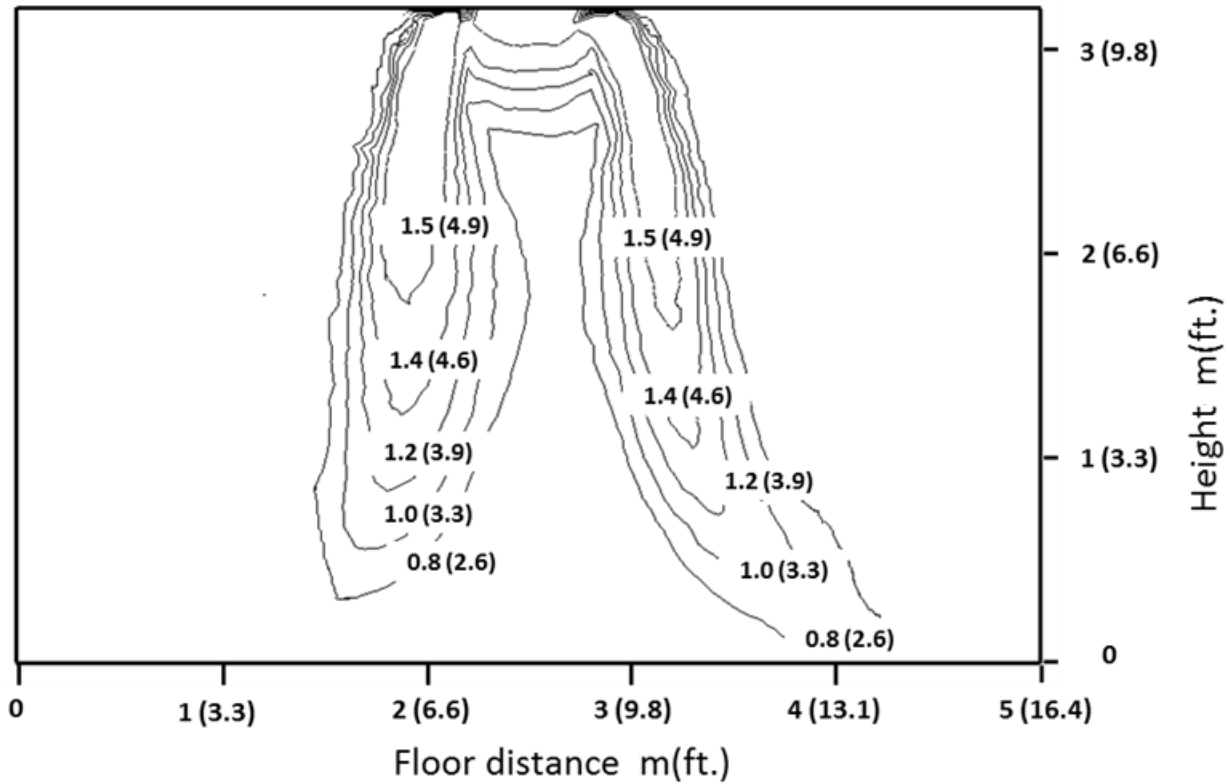

Fig. 19 —Heating mode with 60°swing

SOUND DATA

Sound Pressure Levels

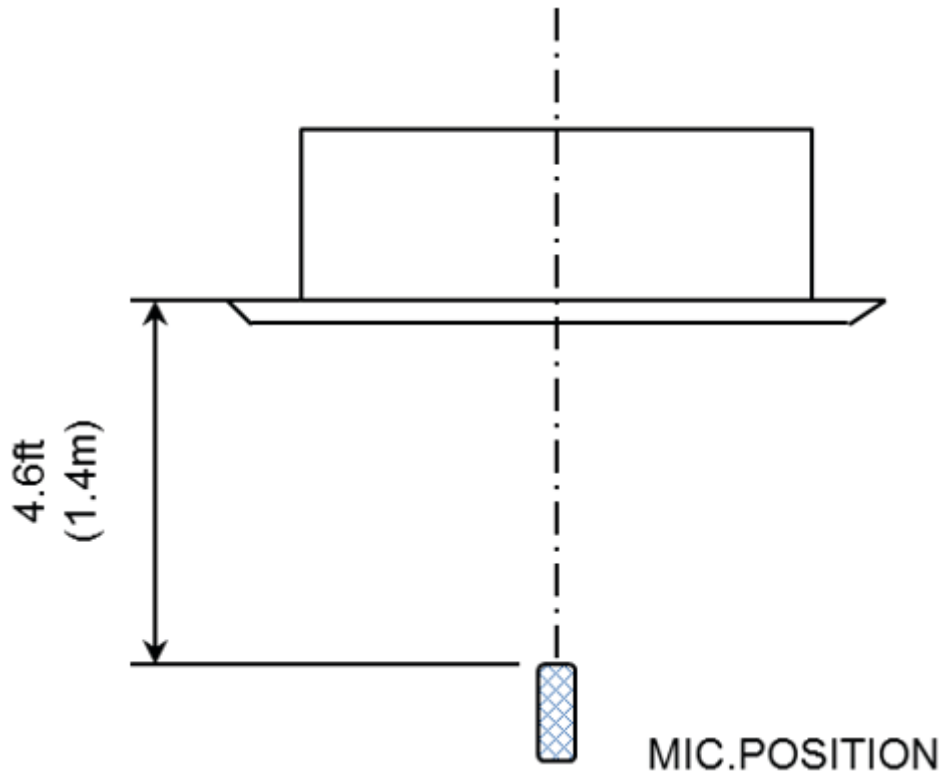

Fig. 20 —Overall Sound Levels

Table 15 —Cooling Mode

MODEL	H	M	L
40VMF009A--3	36.7	34.0	32.1
40VMF012A--3	41.3	37.3	33.0
40VMF015A--3	45.2	41.5	36.9
40VMF018A--3	52.5	43.1	40.2
40VMF024A--3	44.6	42.5	40.2
40VMF030A--3	48.8	45.1	42.1
40VMF036A--3	53.4	50.0	47.3
40VMF048A--3	55.1	52.8	50.2

NOTE: Units are in dBA

Table 16 —Heating Mode

MODEL	H	M	L
40VMF009A--3	36.3	32.6	29.3
40VMF012A--3	41.4	36.5	32.6
40VMF015A--3	45.6	40.7	37.0
40VMF018A--3	52.8	42.7	39.4
40VMF024A--3	44.7	41.4	38.5
40VMF030A--3	48.9	44.7	41.4
40VMF036A--3	53.9	50.4	46.8
40VMF048A--3	55.1	54.0	50.5

NOTE: Units are in dBA

NC Curves

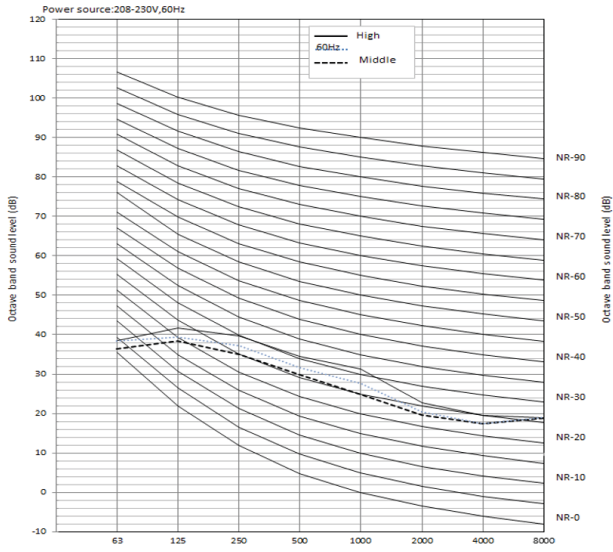

Fig. 21 —40VMF009A--3

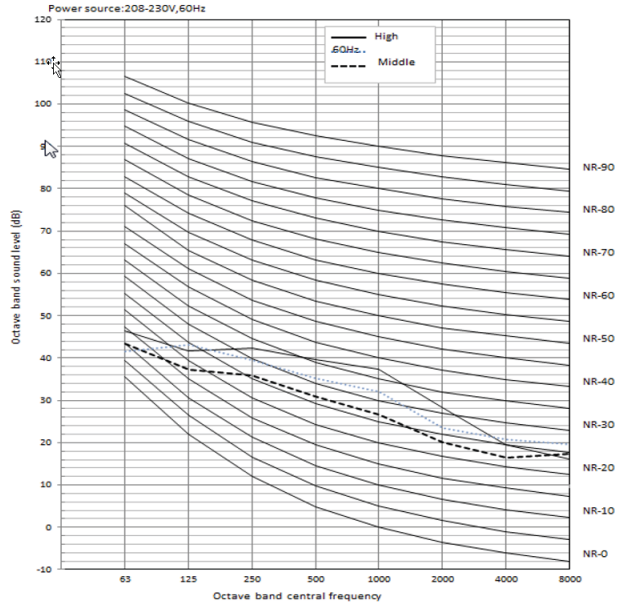

Fig. 22 —40VMF012A--3

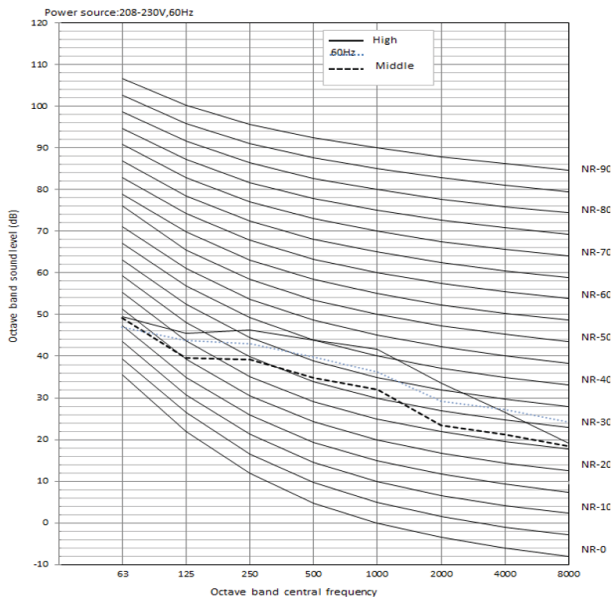

Fig. 23 —40VMF015A--3

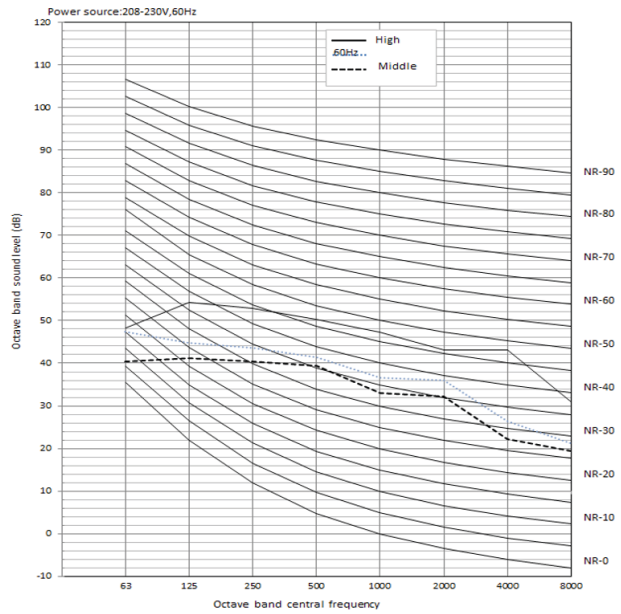

Fig. 24 —40VMF018A--3

NC Curves (Cont.)

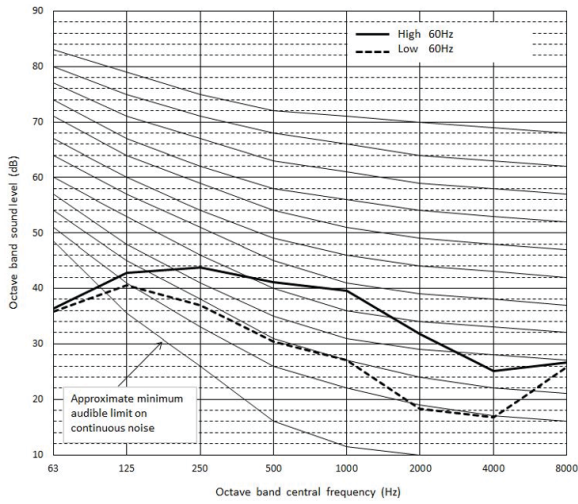

Fig. 25 —40VMF024A--3

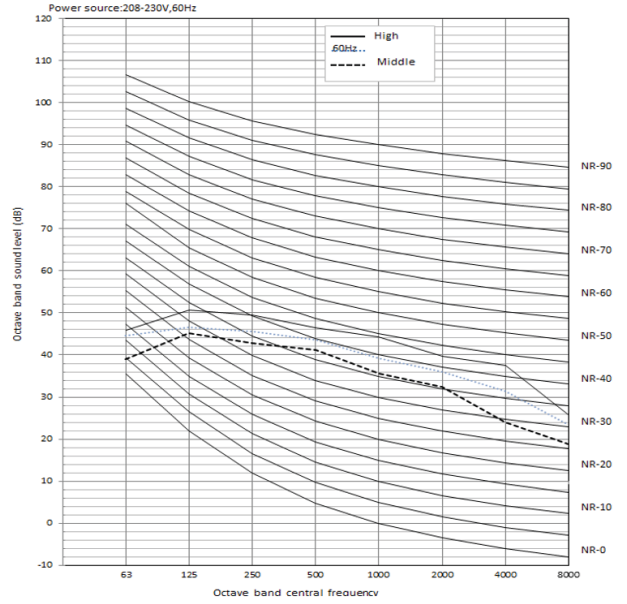

Fig. 26 —40VMF030A--3

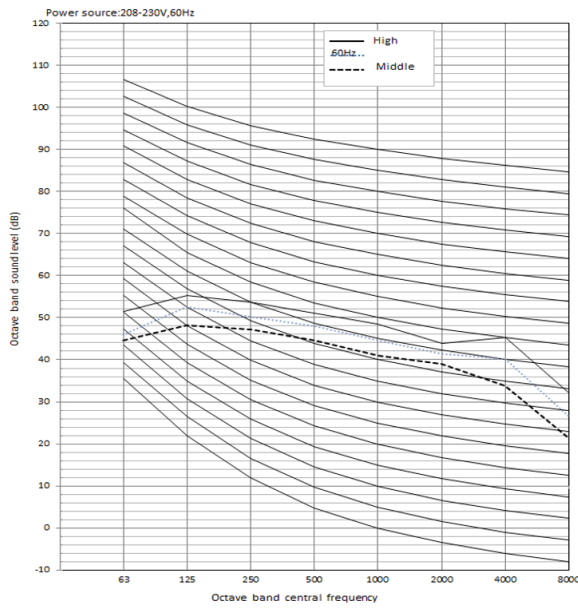

Fig. 27 —40VMF036A--3

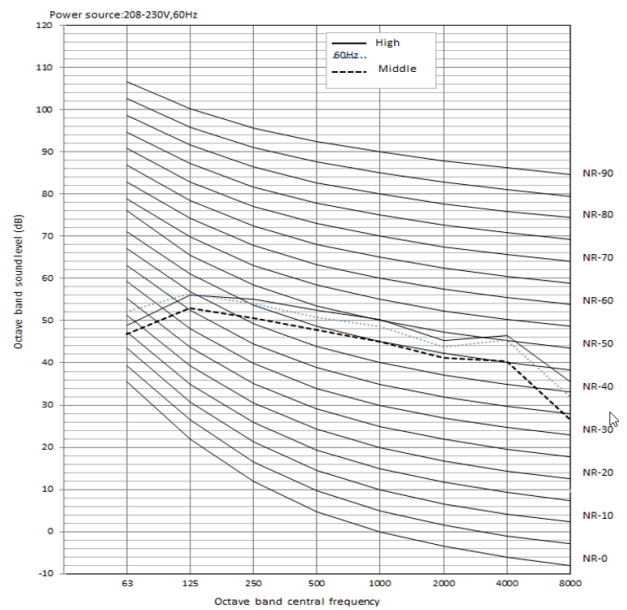

Fig. 28 —40VMF048A--3

CAPACITY DATA TABLES

Table 17 —Cooling Capacity

Model	Outdoor air temp.	Indoor air temp.													
		71 °DB/59 °WB		73 °DB/61 °WB		77 °DB/64 °WB		80 °DB/67 °WB		82 °DB/68 °WB		86 °DB/72 °WB		90 °DB/75 °WB	
kbtu/h	°F D.B.	TC	SC	TC	SC	TC	SC	TC	SC	TC	SC	TC	SC	TC	SC
9	68	8.2	8.1	8.7	8.5	9.2	9.0	9.8	9.3	10.0	9.7	10.7	9.7	11.2	10.1
	73	8.2	8.1	8.7	8.5	9.2	9.0	9.8	9.3	10.0	9.7	10.7	9.7	11.2	10.0
	77	8.1	8.1	8.7	8.5	9.2	8.9	9.7	9.2	9.9	9.6	10.5	9.6	11.0	9.9
	82	8.1	8.0	8.5	8.4	9.0	8.9	9.5	9.1	9.7	9.5	10.3	9.5	10.8	9.9
	86	8.1	8.0	8.4	8.4	8.9	8.8	9.4	9.0	9.6	9.4	10.2	9.4	10.6	9.8
	91	7.9	7.9	8.2	8.2	8.7	8.7	9.2	8.9	9.3	9.3	9.9	9.2	10.4	9.6
	95	7.8	7.8	8.1	8.1	8.6	8.6	9.0	8.8	9.2	9.2	9.7	9.1	10.2	9.5
	100	7.7	7.7	8.0	8.0	8.4	8.5	8.8	8.7	9.0	9.1	9.5	9.1	9.9	9.4
	104	7.6	7.7	7.8	7.9	8.2	8.4	8.6	8.6	8.8	9.0	9.3	9.0	9.7	9.3
110	7.4	7.6	7.6	7.9	7.9	8.2	8.4	8.5	8.5	8.8	9.1	8.8	9.4	9.1	
12	68	10.9	10.1	11.6	10.2	12.3	10.7	13.0	10.6	13.4	11.1	14.3	11.0	15.0	11.3
	73	10.9	10.1	11.6	10.2	12.3	10.6	13.0	10.5	13.3	11.1	14.2	10.9	14.9	11.3
	77	10.9	10.1	11.6	10.2	12.2	10.6	13.0	10.5	13.2	11.0	14.0	10.8	14.7	11.2
	82	10.8	10.0	11.4	10.1	12.0	10.5	12.7	10.3	12.9	10.9	13.7	10.7	14.4	11.1
	86	10.7	9.9	11.2	10.0	11.9	10.4	12.5	10.2	12.8	10.8	13.5	10.6	14.1	11.0
	91	10.6	9.8	11.0	9.8	11.6	10.3	12.2	10.1	12.4	10.7	13.2	10.4	13.8	10.8
	95	10.4	9.7	10.8	9.7	11.4	10.1	12.0	10.0	12.2	10.5	13.0	10.3	13.6	10.7
	100	10.2	9.6	10.6	9.6	11.2	10.0	11.8	9.8	12.0	10.4	12.7	10.2	13.2	10.6
	104	10.1	9.5	10.4	9.5	10.9	9.9	11.5	9.8	11.7	10.3	12.4	10.1	13.0	10.5
110	9.9	9.4	10.2	9.4	10.6	9.7	11.2	9.7	11.4	10.1	12.1	9.9	12.6	10.3	
15	68	13.6	12.4	14.5	12.6	15.4	13.1	16.3	13.0	16.7	13.7	17.8	13.5	18.7	13.9
	73	13.6	12.4	14.5	12.5	15.4	13.0	16.3	12.9	16.7	13.6	17.8	13.4	18.7	13.8
	77	13.6	12.3	14.5	12.5	15.3	13.0	16.2	12.9	16.6	13.5	17.5	13.3	18.4	13.7
	82	13.5	12.3	14.2	12.4	15.1	12.9	15.9	12.7	16.2	13.4	17.1	13.2	18.0	13.6
	86	13.4	12.2	14.0	12.3	14.9	12.8	15.6	12.6	16.0	13.2	16.9	13.0	17.7	13.5
	91	13.2	12.1	13.7	12.0	14.6	12.7	15.3	12.4	15.6	13.1	16.5	12.8	17.3	13.2
	95	13.0	12.0	13.5	11.9	14.3	12.4	15.0	12.3	15.3	12.9	16.2	12.7	17.0	13.1
	100	12.8	11.8	13.3	11.8	14.0	12.3	14.7	12.1	14.9	12.8	15.8	12.6	16.5	13.0
	104	12.6	11.7	13.0	11.7	13.7	12.2	14.4	12.0	14.6	12.6	15.5	12.4	16.2	12.8
110	12.4	11.6	12.7	11.6	13.3	12.0	14.0	11.9	14.2	12.4	15.1	12.2	15.7	12.6	
18	68	16.4	14.6	17.4	14.8	18.5	15.4	19.6	15.3	20.0	16.1	21.4	15.8	22.4	16.3
	73	16.3	14.6	17.4	14.8	18.4	15.4	19.5	15.2	20.0	16.0	21.3	15.8	22.4	16.3
	77	16.3	14.5	17.4	14.7	18.4	15.3	19.4	15.2	19.9	15.9	21.0	15.6	22.0	16.1
	82	16.2	14.5	17.1	14.6	18.1	15.2	19.1	14.9	19.4	15.7	20.6	15.5	21.6	16.0
	86	16.1	14.4	16.8	14.5	17.8	15.1	18.7	14.8	19.1	15.6	20.3	15.3	21.2	15.8
	91	15.9	14.2	16.5	14.2	17.5	14.9	18.4	14.7	18.7	15.4	19.8	15.1	20.7	15.5
	95	15.6	14.1	16.2	14.1	17.1	14.6	18.0	14.5	18.3	15.2	19.5	14.9	20.4	15.4
	100	15.4	13.9	16.0	13.9	16.7	14.5	17.6	14.2	17.9	15.0	19.0	14.8	19.8	15.2
	104	15.1	13.8	15.6	13.8	16.4	14.4	17.3	14.1	17.6	14.9	18.7	14.6	19.4	15.1
110	14.9	13.7	15.2	13.6	15.9	14.1	16.8	14.0	17.1	14.6	18.2	14.4	18.8	14.8	

Model	Outdoor air temp.	Indoor air temp.													
		71 °DB/59 °WB		73 °DB/61 °WB		77 °DB/64 °WB		80 °DB/67 °WB		82 °DB/68 °WB		86 °DB/72 °WB		90 °DB/75 °WB	
kbtu/h	°F D.B.	TC	SC	TC	SC	TC	SC	TC	SC	TC	SC	TC	SC	TC	SC
24	68	21.8	18.0	23.2	18.3	24.6	19.0	26.1	18.8	26.7	19.7	28.5	19.4	29.9	19.9
	73	21.8	18.0	23.2	18.2	24.6	18.9	26.0	18.8	26.6	19.6	28.5	19.3	29.9	19.9
	77	21.7	18.0	23.2	18.2	24.5	18.8	25.9	18.7	26.5	19.6	28.1	19.2	29.4	19.7
	82	21.6	17.9	22.7	18.1	24.1	18.7	25.4	18.4	25.8	19.3	27.4	19.0	28.7	19.5
	86	21.5	17.8	22.4	17.9	23.8	18.6	25.0	18.2	25.5	19.1	27.1	18.8	28.3	19.3
	91	21.2	17.6	21.9	17.5	23.3	18.4	24.5	18.1	24.9	18.9	26.5	18.5	27.6	19.0
	95	20.8	17.4	21.6	17.4	22.8	18.0	24.0	17.9	24.4	18.6	26.0	18.3	27.2	18.8
	100	20.5	17.2	21.3	17.2	22.3	17.9	23.5	17.5	23.9	18.4	25.3	18.1	26.4	18.6
	104	20.2	17.1	20.8	17.0	21.8	17.7	23.0	17.4	23.4	18.2	24.9	18.0	25.9	18.4
110	19.9	16.9	20.3	16.8	21.2	17.3	22.4	17.2	22.8	17.9	24.2	17.6	25.1	18.1	
30	68	27.3	21.3	29.0	21.7	30.8	22.4	32.6	22.2	33.4	23.2	35.7	22.8	37.4	23.4
	73	27.2	21.3	29.0	21.6	30.7	22.3	32.5	22.1	33.3	23.1	35.6	22.8	37.3	23.3
	77	27.1	21.2	28.9	21.5	30.6	22.2	32.4	22.0	33.1	23.0	35.1	22.6	36.7	23.1
	82	27.0	21.2	28.4	21.4	30.1	22.1	31.8	21.7	32.3	22.7	34.3	22.4	35.9	22.9
	86	26.8	21.0	28.0	21.2	29.7	21.9	31.2	21.5	31.9	22.5	33.9	22.1	35.4	22.7
	91	26.4	20.8	27.4	20.8	29.1	21.7	30.6	21.3	31.1	22.3	33.1	21.7	34.6	22.3
	95	26.0	20.6	27.0	20.6	28.5	21.3	30.0	21.1	30.5	21.9	32.5	21.5	34.0	22.1
	100	25.6	20.4	26.6	20.4	27.9	21.1	29.4	20.7	29.9	21.7	31.7	21.3	33.0	21.8
	104	25.2	20.2	26.0	20.1	27.3	20.9	28.8	20.5	29.3	21.4	31.1	21.1	32.4	21.6
110	24.8	20.0	25.4	19.9	26.5	20.5	28.0	20.3	28.5	21.0	30.3	20.7	31.4	21.2	
36	68	32.7	25.6	34.9	26.1	37.0	26.9	39.1	26.7	40.1	27.9	42.8	27.5	44.9	28.1
	73	32.7	25.6	34.8	26.0	36.9	26.8	39.0	26.6	40.0	27.8	42.7	27.4	44.8	28.0
	77	32.6	25.6	34.7	25.9	36.7	26.7	38.9	26.5	39.7	27.7	42.1	27.1	44.1	27.8
	82	32.5	25.5	34.1	25.7	36.1	26.6	38.2	26.1	38.8	27.3	41.1	26.9	43.1	27.5
	86	32.2	25.3	33.6	25.5	35.7	26.3	37.4	25.9	38.3	27.1	40.7	26.7	42.4	27.3
	91	31.7	25.0	32.9	25.0	34.9	26.1	36.7	25.6	37.3	26.8	39.7	26.2	41.5	26.8
	95	31.2	24.8	32.4	24.7	34.2	25.6	36.0	25.4	36.6	26.3	39.0	25.9	40.8	26.5
	100	30.8	24.5	31.9	24.5	33.5	25.3	35.3	24.9	35.9	26.1	38.0	25.7	39.6	26.3
	104	30.3	24.3	31.2	24.2	32.8	25.1	34.6	24.7	35.2	25.8	37.3	25.4	38.9	26.0
110	29.8	24.0	30.5	24.0	31.8	24.6	33.6	24.4	34.2	25.3	36.3	24.9	37.7	25.5	
48	68	43.6	31.6	46.5	32.2	49.3	33.2	52.2	32.9	53.4	34.2	57.1	33.7	59.8	34.3
	73	43.5	31.6	46.4	32.1	49.2	33.1	52.0	32.8	53.3	34.1	56.9	33.6	59.7	34.2
	77	43.4	31.6	46.3	32.0	49.0	32.9	51.8	32.7	53.0	33.9	56.1	33.3	58.8	33.9
	82	43.3	31.5	45.5	31.8	48.2	32.7	50.9	32.2	51.7	33.5	54.8	33.0	57.5	33.6
	86	43.0	31.2	44.9	31.5	47.5	32.4	49.9	31.9	51.0	33.2	54.2	32.7	56.6	33.3
	91	42.3	30.9	43.9	30.9	46.6	32.1	49.0	31.6	49.8	32.8	52.9	32.1	55.3	32.7
	95	41.7	30.6	43.2	30.6	45.6	31.5	48.0	31.3	48.8	32.2	52.0	31.8	54.4	32.4
	100	41.0	30.3	42.6	30.3	44.7	31.2	47.0	30.7	47.8	31.9	50.7	31.5	52.8	32.0
	104	40.3	30.0	41.6	30.0	43.7	30.9	46.1	30.4	46.9	31.6	49.7	31.2	51.8	31.7
110	39.7	29.7	40.7	29.7	42.4	30.3	44.8	30.1	45.6	31.0	48.5	30.6	50.2	31.1	

TC : Total Cooling
SC : Sensible Cooling

Table 18 —Heating Capacity

Model	Outdoor air temp.	Indoor air temp.			
		59 °DB	70 °DB	77 °DB	81 °DB
kbtu/h	° F D.B.	TC	TC	TC	TC
9	5	5.9	6.4	6.1	5.8
	14	6.9	7.4	7.1	6.8
	23	8.0	8.4	8.1	7.5
	32	9.1	9.4	8.4	7.5
	37	9.7	10.0	8.4	7.5
	43	10.3	10.0	8.4	7.5
	47	10.7	10.0	8.4	7.5
	50	11.2	10.0	8.4	7.5
	55	11.6	10.0	8.4	7.5
	60	11.6	10.0	8.4	7.5
12	5	7.9	8.6	8.2	7.9
	14	9.4	10.0	9.6	9.2
	23	10.8	11.4	11.0	10.2
	32	12.2	12.7	11.4	10.2
	37	13.0	13.5	11.4	10.2
	43	13.9	13.5	11.4	10.2
	47	14.5	13.5	11.4	10.2
	50	15.1	13.5	11.4	10.2
	55	15.7	13.5	11.4	10.2
	60	15.7	13.5	11.4	10.2
15	5	9.9	10.9	10.4	9.9
	14	11.8	12.6	12.1	11.6
	23	13.6	14.3	13.8	12.8
	32	15.4	16.0	14.3	12.8
	37	16.4	17.0	14.3	12.8
	43	17.5	17.0	14.3	12.8
	47	18.3	17.0	14.3	12.8
	50	19.0	17.0	14.3	12.8
	55	19.7	17.0	14.3	12.8
	60	19.7	17.0	14.3	12.8
18	5	12.3	13.4	12.8	12.2
	14	14.6	15.5	14.9	14.3
	23	16.7	17.7	17.1	15.8
	32	19.0	19.8	17.7	15.8
	37	20.3	21.0	17.7	15.8
	43	21.6	21.0	17.7	15.8
	47	22.6	21.0	17.7	15.8
	50	23.5	21.0	17.7	15.8
	55	24.4	21.0	17.7	15.8
	60	24.4	21.0	17.7	15.8
24	5	15.8	17.3	16.4	15.7
	14	18.7	20.0	19.2	18.4
	23	21.5	22.7	22.0	20.4
	32	24.4	25.4	22.8	20.4
	37	26.1	27.0	22.8	20.4
	43	27.8	27.0	22.8	20.4
	47	29.0	27.0	22.8	20.4
	50	30.2	27.0	22.8	20.4
	55	31.3	27.0	22.8	20.4
	60	31.3	27.0	22.8	20.4
65	31.3	27.0	22.8	20.4	

Model	Outdoor air temp.	Indoor air temp.			
		59 °DB	70 °DB	77 °DB	81 °DB
kbtu/h	°F D.B.	TC	TC	TC	TC
30	5	19.9	21.8	20.7	19.8
	14	23.6	25.2	24.2	23.1
	23	27.1	28.6	27.7	25.7
	32	30.8	32.0	28.7	25.7
	37	32.8	34.0	28.7	25.7
	43	35.0	34.0	28.7	25.7
	47	36.5	34.0	28.7	25.7
	50	38.0	34.0	28.7	25.7
	55	39.4	34.0	28.7	25.7
	60	39.4	34.0	28.7	25.7
36	5	23.4	25.6	24.4	23.3
	14	27.7	29.6	28.5	27.2
	23	31.9	33.7	32.5	30.2
	32	36.2	37.6	33.8	30.2
	37	38.6	40.0	33.8	30.2
	43	41.2	40.0	33.8	30.2
	47	43.0	40.0	33.8	30.2
	50	44.7	40.0	33.8	30.2
	55	46.4	40.0	33.8	30.2
	60	46.4	40.0	33.8	30.2
48	5	31.6	34.5	32.9	31.4
	14	37.4	40.0	38.4	36.8
	23	43.0	45.5	43.9	40.7
	32	48.9	50.8	45.6	40.7
	37	52.2	54.0	45.6	40.7
	43	55.7	54.0	45.6	40.7
	47	58.0	54.0	45.6	40.7
	50	60.3	54.0	45.6	40.7
	55	62.6	54.0	45.6	40.7
	60	62.6	54.0	45.6	40.7
65	62.6	54.0	45.6	40.7	

TC : Total Cooling

