

SMMSe / SHRMe VRF Indoor Unit MMK-AP0187HPUL—HIGH WALL



Submittal Data

Job Name _____ Location _____
Tag _____



SMMSe / SHRMe VRF High Wall Features

- R-410A refrigerant
- Six sizes from 7,500 to 24,000 Btu/h
- Quiet operation, as low as 27 dBA
- Vertical airflow can be set to swing or fixed position
- Air throw up to 23 feet
- Auto or manually set three fan speeds
- Easy to remove cleanable filter
- Five-year parts limited warranty

INDOOR UNIT MODEL		MMK-AP0187HPUL
PERFORMANCE		
Cooling Rated Capacity	Btu/h	18,000
Heating Rated Capacity	Btu/h	20,000
Fan Type (Qty)		Cross-Flow (1)
Airflow (H / M / L)	CFM	530 / 424 / 324
Sound Pressure (H / M / L)	dBA	41 / 37 / 32
FILTER (Standard)		
Type		Washable
Quantity		2
MERV Corresponding Value		5
Dimensions (W x L x D)	in.	15-3/4 x 16-3/8 x 1/16
ELECTRICAL		
Power Supply	V/Ph/Hz	208-230/1/60
Power Consumption (Input)	kW	0.032
Full Load Amps (FLA)	A	0.33
Minimum Circuit Amps (MCA)	A	0.42
Maximum Overcurrent Protection (MOCP)	A	15.0
MOTOR		
Motor Type		DC
Motor Watts	W	30

PHYSICAL DATA		
Pipe Connection Size - Liquid (High Pressure)	in.	1/4 (Flare)
Pipe Connection Size - Gas (Low Pressure)	in.	1/2 (Flare)
Pipe Connection Size - Drain (OD)	in.	7/8
Pipe Connection Size - Drain (ID)	in.	5/8
Refrigerant		R-410A
External Finish		Munsell 2.5GY9.0/0.5
Unit Width	in.	41-3/8
Unit Height	in.	12-9/16
Unit Depth	in.	9-7/8
Net Weight	lb	36
CONTROLS		
Wireless Remote Controller (Standard)		

ACCESSORIES

- Wired Remote Controller (7-Day Programmable) - RBC-AMS54E-UL
- Simple Wired Remote Control - RBC-AS41UL
- Remote Sensor TCB-TC41LUL
- Wired Remote Controller - RBC-AMT32UL
- Condensate Drain Pump Kit 53DS-900---118

DIMENSIONAL DRAWING INDOOR UNIT HIGH WALL MMK-AP0187HPUL

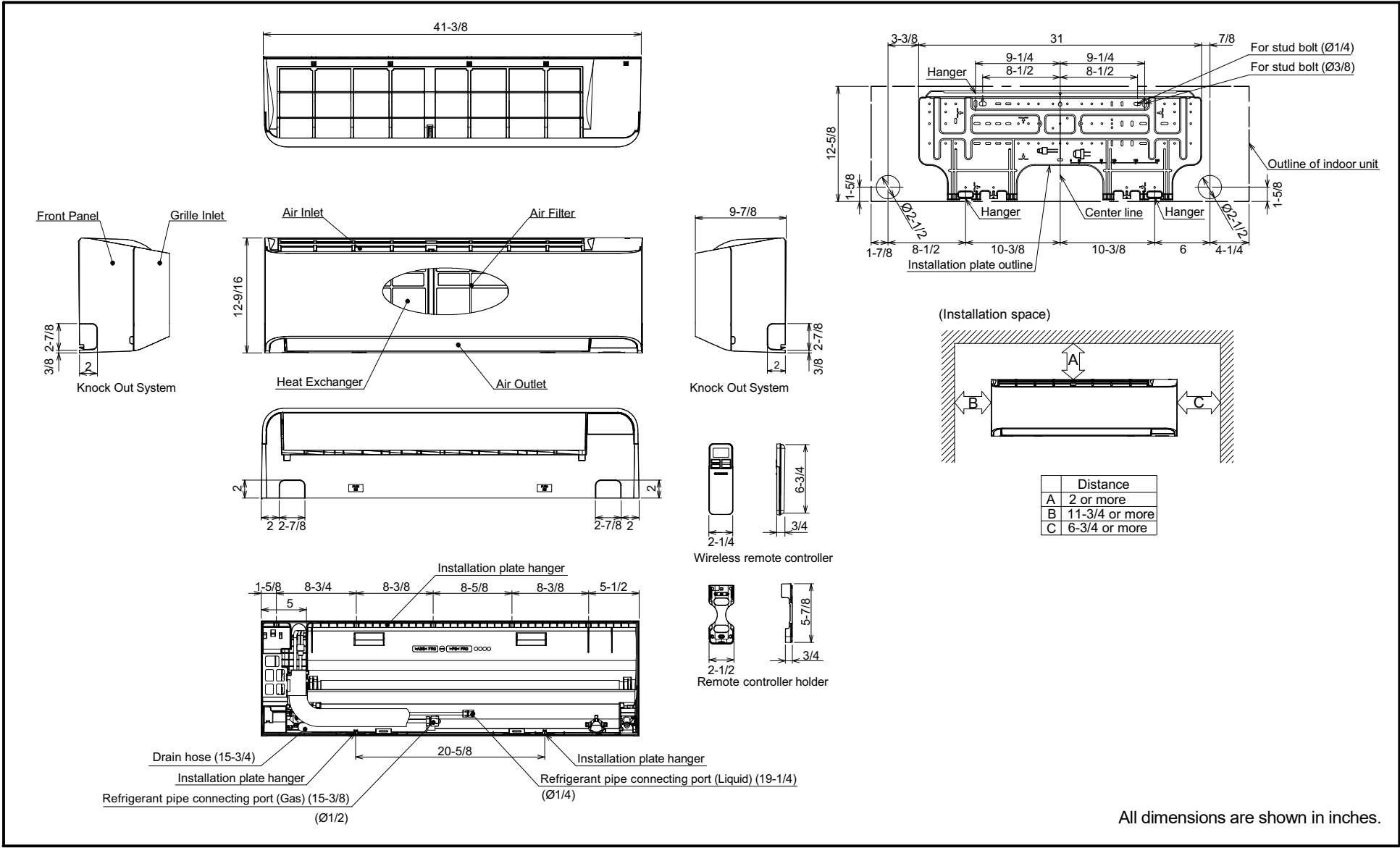

	Distance
A	2 or more
B	11-3/4 or more
C	6-3/4 or more

