

Medium Static Pressure Duct Type

MMD-AP0076BHPUL
MMD-AP0096BHPUL
MMD-AP0126BHPUL
MMD-AP0156BHPUL
MMD-AP0186BHPUL
MMD-AP0216BHPUL
MMD-AP0246BHPUL
MMD-AP0306BHPUL
MMD-AP0426BHPUL
MMD-AP0486BHPUL
MMD-AP0546BHPUL



Contents

1. Specifications
2. Dimensions
3. Center of gravity
4. Piping diagram
5. Wiring diagram
6. Electrical current characteristics
7. Sensible capacity table
8. Fan characteristics
9. Sound data
10. Accessories

1. Specifications

Model name		MMD-	AP0076BHPUL	AP0096BHPUL	AP0126BHPUL	AP0156BHPUL	AP0186BHPUL	AP0216BHPUL
Power supply		1 ph 60Hz 230V (208 / 230V)						
Cooling capacity (*1)		kBtu/h	7.5	9.5	12.0	15.4	18.0	21.0
Sensible cooling capacity		kBtu/h	5.6	7.1	9.0	11.6	13.5	15.8
Heating capacity (*1)		kBtu/h	8.5	10.5	13.5	17.0	20.0	24.0
Power consumption		(kW)	0.07	0.09	0.09	0.13	0.14	0.21
FCU dimension	Main unit	Height (in)	10.9	10.9	10.9	10.9	10.9	10.9
		Width (in)	27.6	27.6	27.6	39.4	39.4	55.2
		Depth (in)	29.6	29.6	29.6	29.6	29.6	29.6
Total weight	Main unit	(lbs)	56	56	56	73	73	93
External static pressure (default) (*2)		in WG	0.4"	0.4"	0.4"	0.4"	0.4"	0.6"
External static pressure (*2)		in WG	0.6"	0.6"	0.6"	0.6"	0.6"	0.8"
Heat exchangere		Finned tube						
Soundproof / Heat-insulation material		Polyethylene foam						
Fan		Centrifugal fan						
Air flow volume	Indoor unit (H/M/L)	(cfm)	318 / 265 / 212	395 / 329 / 263	395 / 329 / 263	589 / 489 / 394	624 / 489 / 394	706 / 583 / 512
Sound pressure	Indoor unit (H/M/L)	dB(A)	39 / 34 / 30	41 / 36 / 32	41 / 36 / 32	44 / 41 / 35	45 / 41 / 35	44 / 34 / 30
Motor output		(W)	150	150	150	150	150	150
Flare Connections	Gas side	(in)	3/8	3/8	3/8	5/8	5/8	5/8
	Liquid side	(in)	1/4	1/4	1/4	3/8	3/8	3/8
	Drain pipe	(in)	VP25((Polyvinyl Chloride Tube: External Dia. 1-1/4 Internal Dia. 1)					
Operating Range for SMMS-I, SMMS-e	Cooling	(°F)	41 ~ 109					
	Heating	(°F)	14 ~ 109					

(*1) Rated testing conditions Cooling : Indoor air temperature 80°F Dry Bulb / 67°F Wet Bulb, Outdoor 95°F Dry Bulb

Heating : Indoor air temperature 70°F Dry Bulb, Outdoor 47°F Dry Bulb / 43°F Wet Bulb

(*2) Non attached filter

Model name		MMD-	AP0246BHPUL	AP0306BHPUL	AP0366BHPUL	AP0426BHPUL	AP0486BHPUL	AP0546BHPUL
Power supply		1 ph 60Hz 230V (208 / 230V)						
Cooling capacity (*1)		kBtu/h	24.0	30.0	36.0	42.0	48.0	54.0
Sensible cooling capacity		kBtu/h	18.0	22.5	27.0	31.5	36.0	40.5
Heating capacity (*1)		kBtu/h	27.0	34.0	40.0	47.5	54.0	60.0
Power consumption		(kW)	0.21	0.22	0.33	0.33	0.34	0.34
FCU dimension	Main unit	Height (in)	10.9	10.9	10.9	10.9	10.9	10.9
		Width (in)	55.2	55.2	55.2	55.2	55.2	55.2
		Depth (in)	29.6	29.6	29.6	29.6	29.6	29.6
Total weight	Main unit	(lbs)	93	93	93	93	93	93
External static pressure (default) (*2)		in WG	0.6"	0.6"	0.6"	0.6"	0.6"	0.6"
External static pressure (*2)		in WG	0.8"	0.8"	0.8"	0.8"	0.8"	0.8"
Heat exchangere		Finned tube						
Soundproof / Heat-insulation material		Polyethylene foam						
Fan		Centrifugal fan						
Air flow volume	Indoor unit (H/M/L)	(cfm)	706 / 583 / 512	742 / 653 / 547	1130 / 954 / 812	1130 / 954 / 812	1177 / 1024 / 883	1177 / 1024 / 883
Sound pressure	Indoor unit (H/M/L)	dB(A)	44 / 34 / 30	45 / 35 / 31	46 / 41 / 37	46 / 41 / 37	47 / 42 / 38	47 / 42 / 38
Motor output		(W)	150	150	250	250	250	250
Flare Connections	Gas side	(in)	5/8	5/8	5/8	5/8	5/8	5/8
	Liquid side	(in)	3/8	3/8	3/8	3/8	3/8	3/8
	Drain pipe	(in)	VP25((Polyvinyl Chloride Tube: External Dia. 1-1/4 Internal Dia. 1)					
Operating Range for SMMS-I, SMMS-e	Cooling	(°F)	41 ~ 109					
	Heating	(°F)	14 ~ 109					

(*1) Rated testing conditions Cooling : Indoor air temperature 80°F Dry Bulb / 67°F Wet Bulb, Outdoor 95°F Dry Bulb
 Heating : Indoor air temperature 70°F Dry Bulb, Outdoor 47°F Dry Bulb / 43°F Wet Bulb

(*2) Non attached filter

2. Dimension

MMD-AP0076BHPUL / AP0096BHPUL / AP0126BHPUL

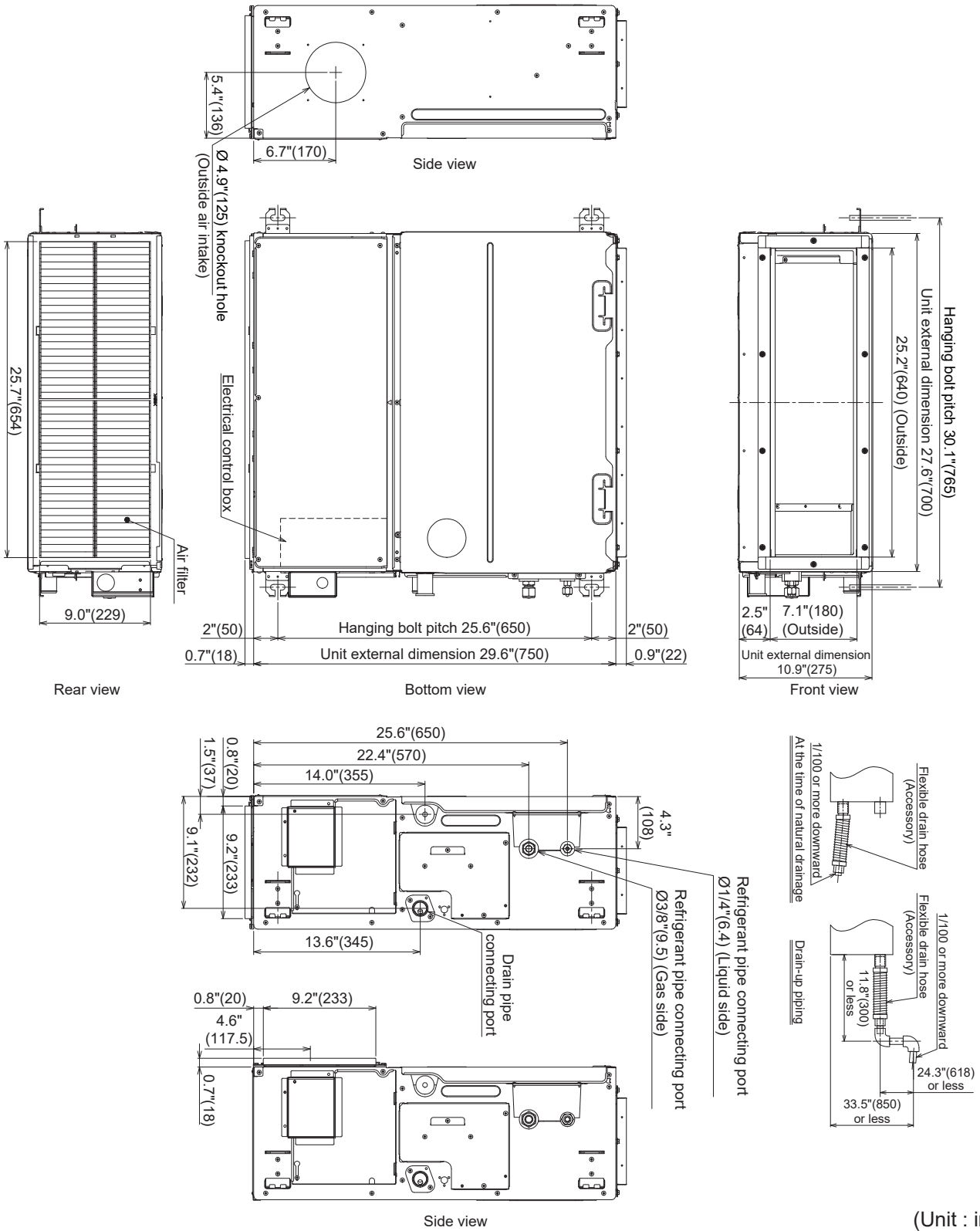

(Unit : in)

For duct design MMD-AP0076* / 096* / 126*

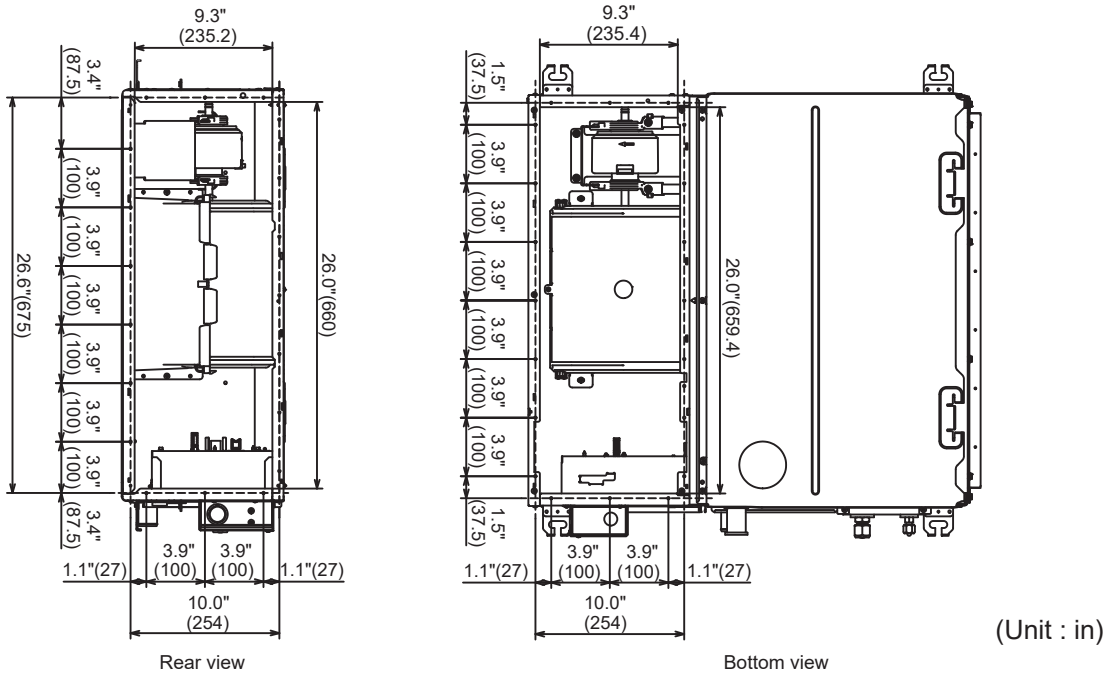

Space required for installation and servicing

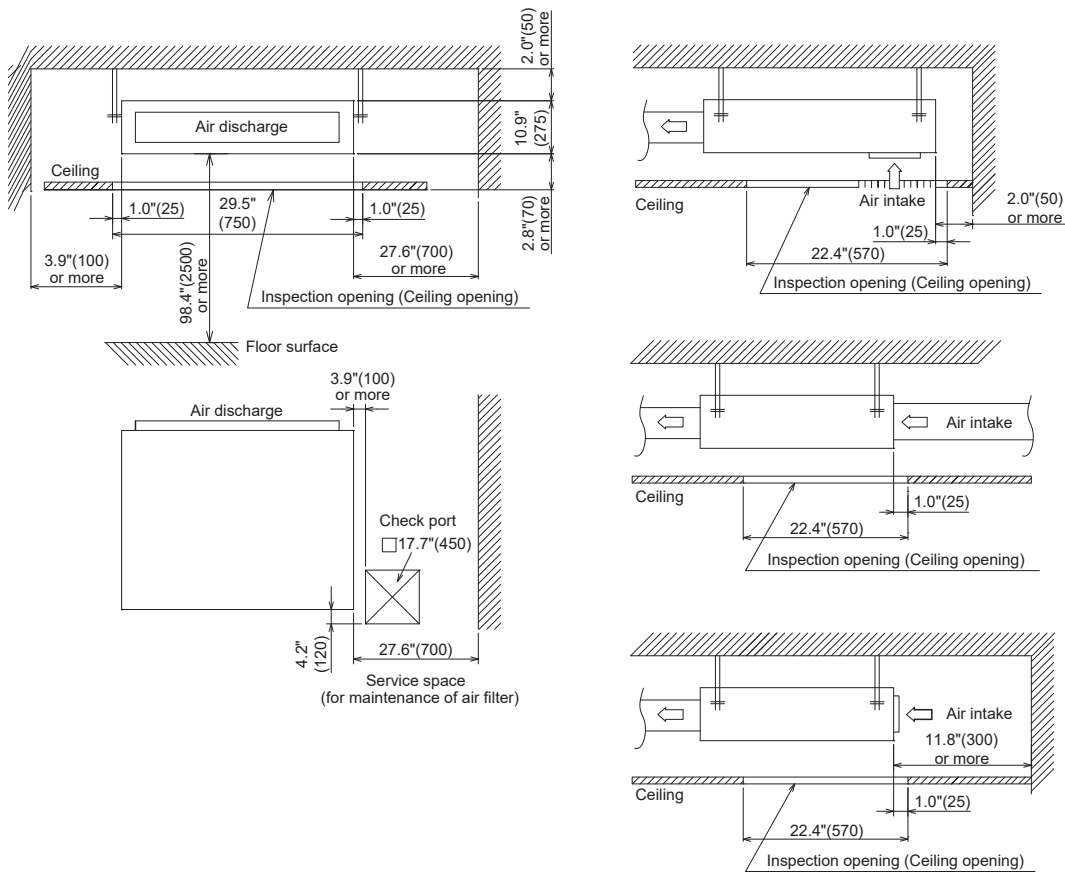

MMD-AP0156BHPUL / AP0186BHPUL

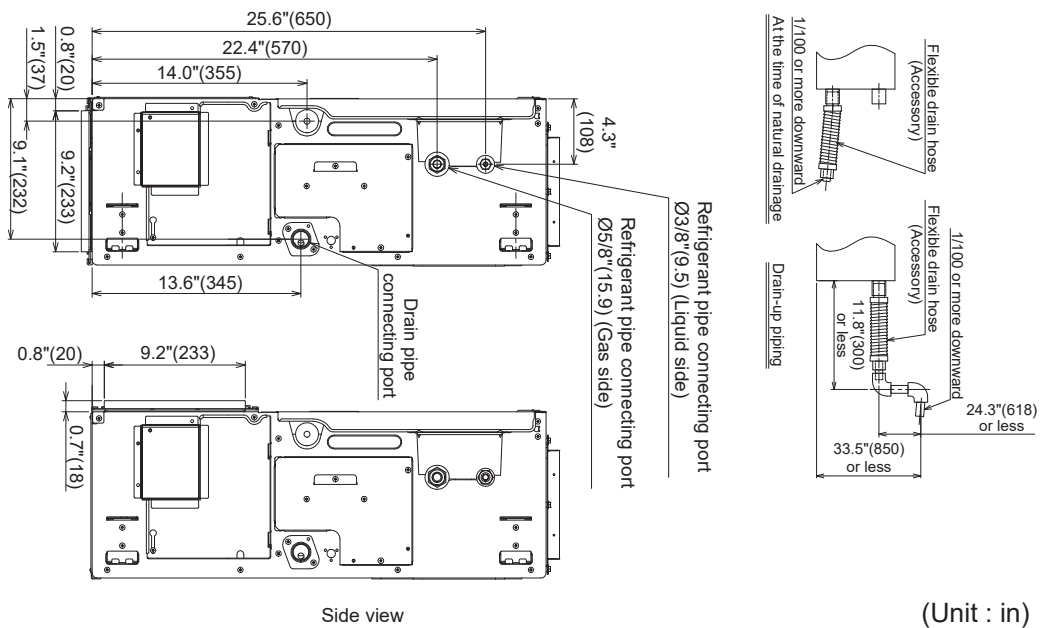
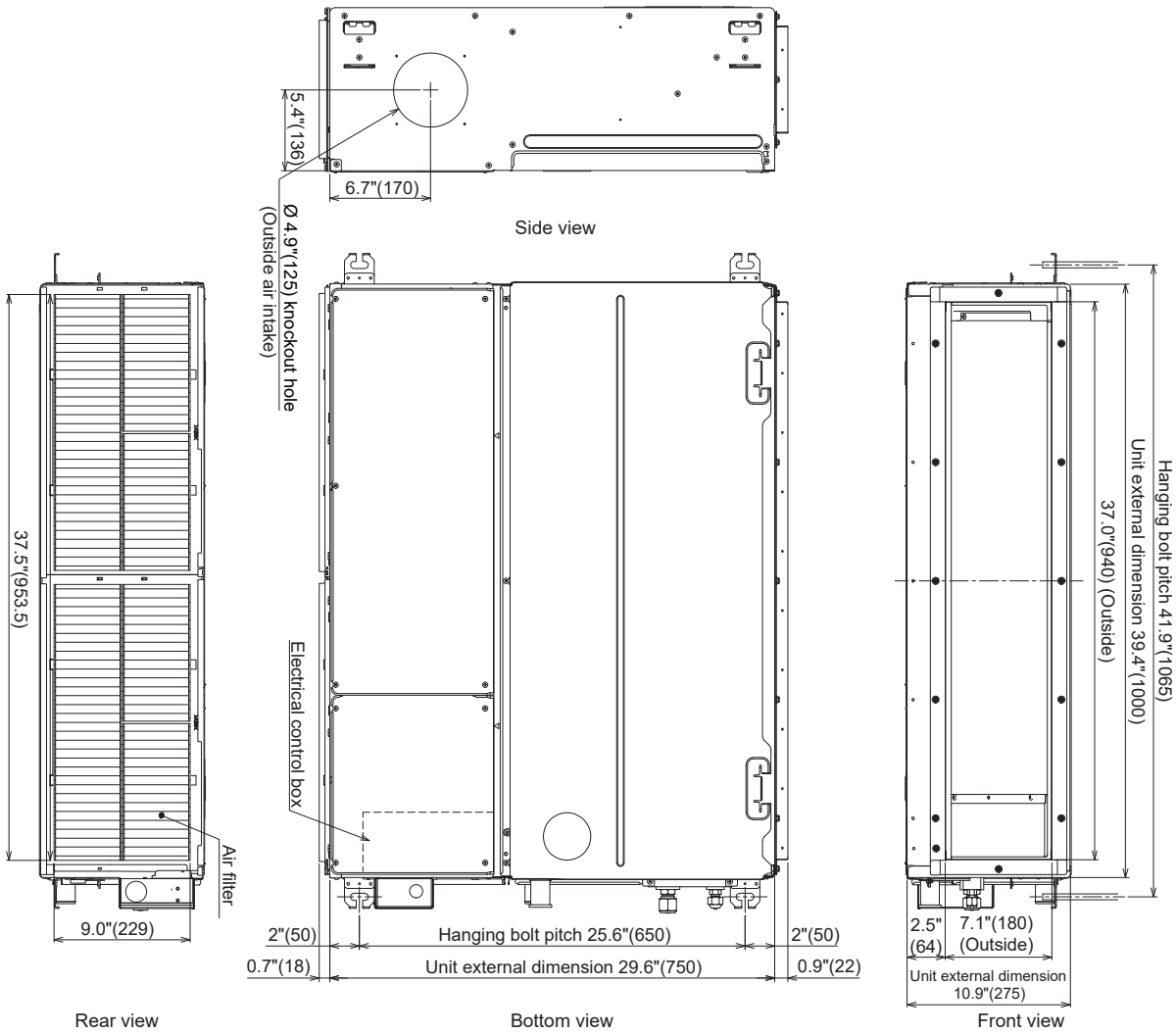

(Unit : in)

For duct design MMD-AP0156* / 186*

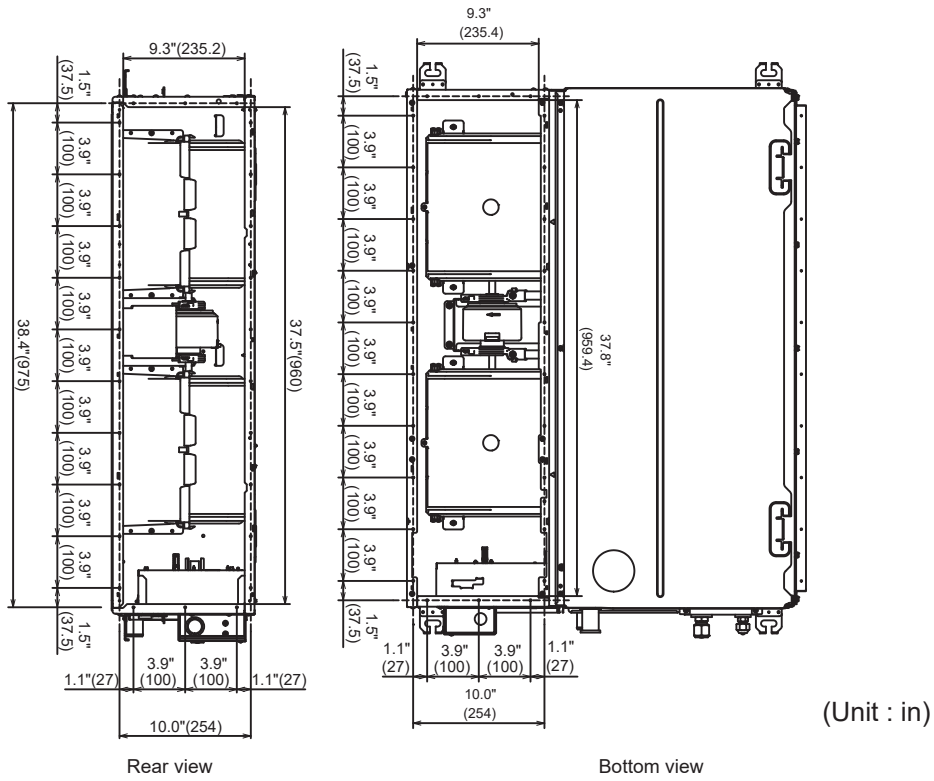

Space required for installation and servicing

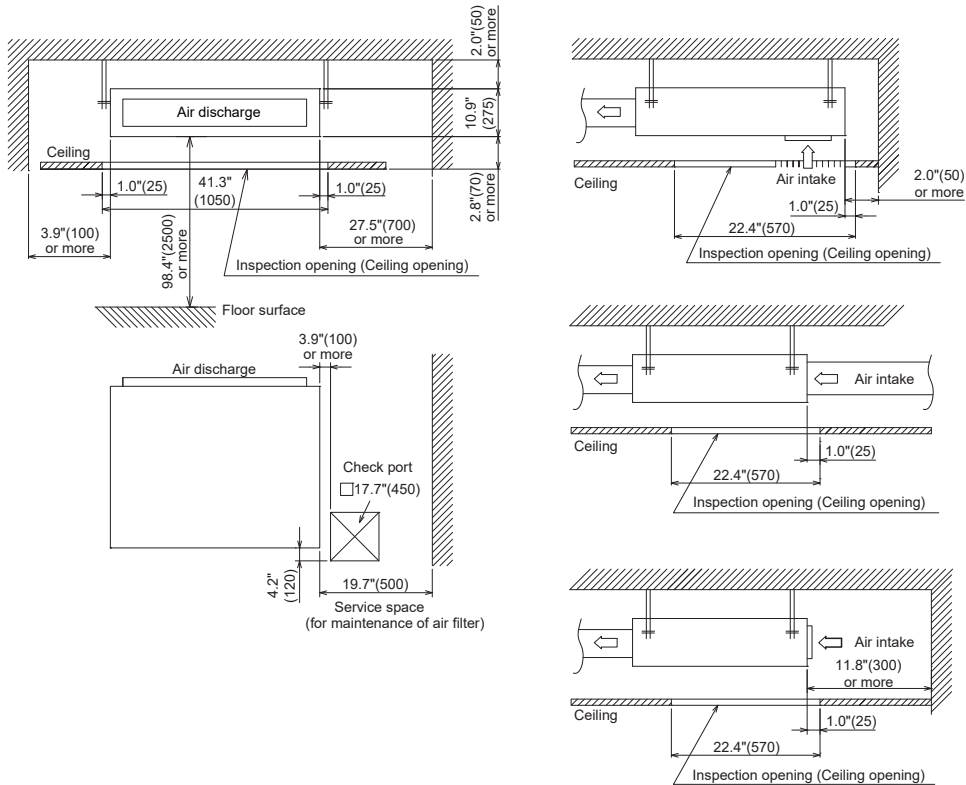

MMD-AP0216BHPUL / AP0246BHPUL / AP0306BHPUL / AP0366BHPUL / AP0426BHPUL / AP0486BHPUL / AP0546BHPUL

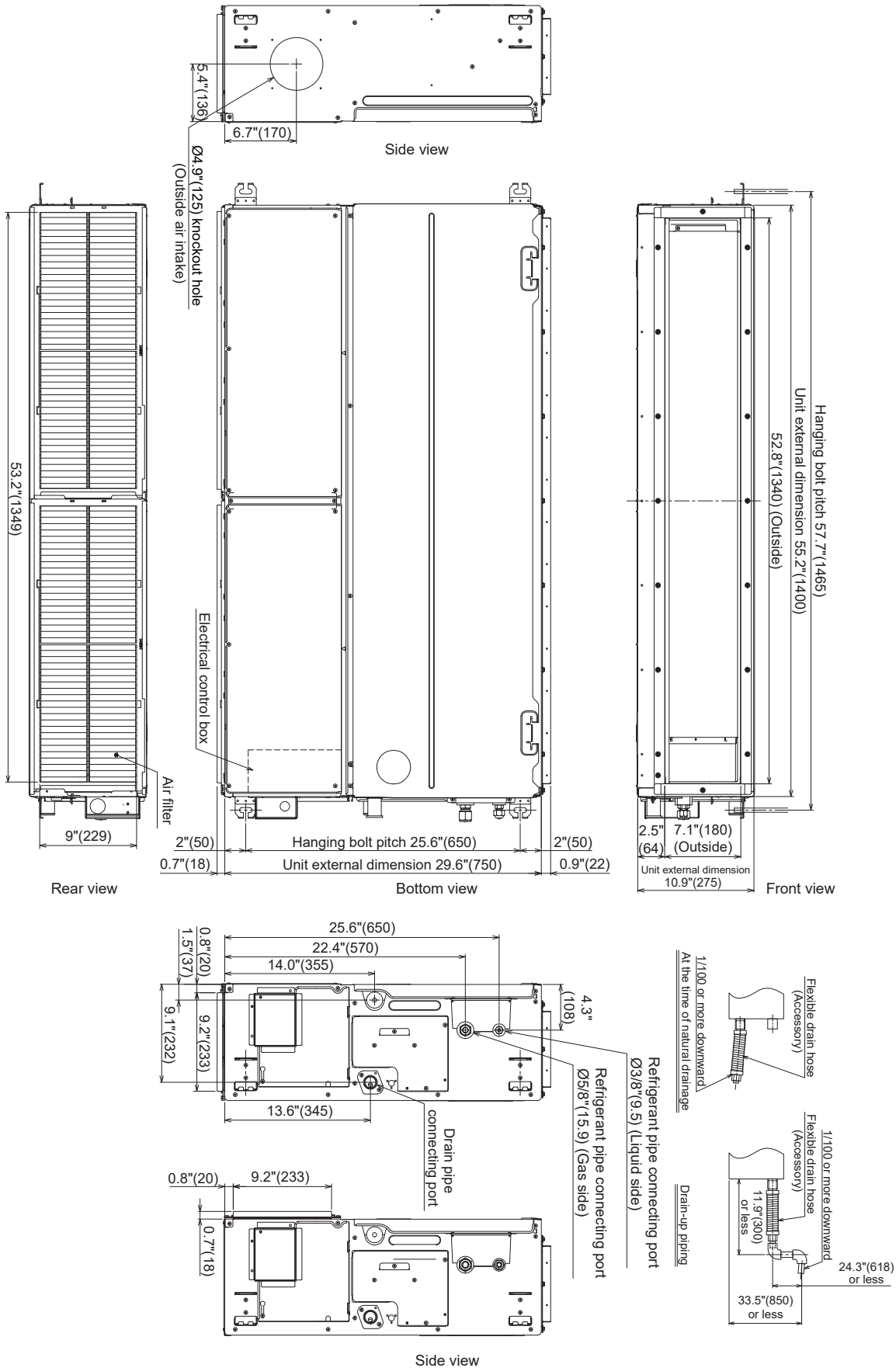

(Unit : in)

For duct design MMD-AP0216* / 246* / 306* / 366* / 426* / 486* / 546*

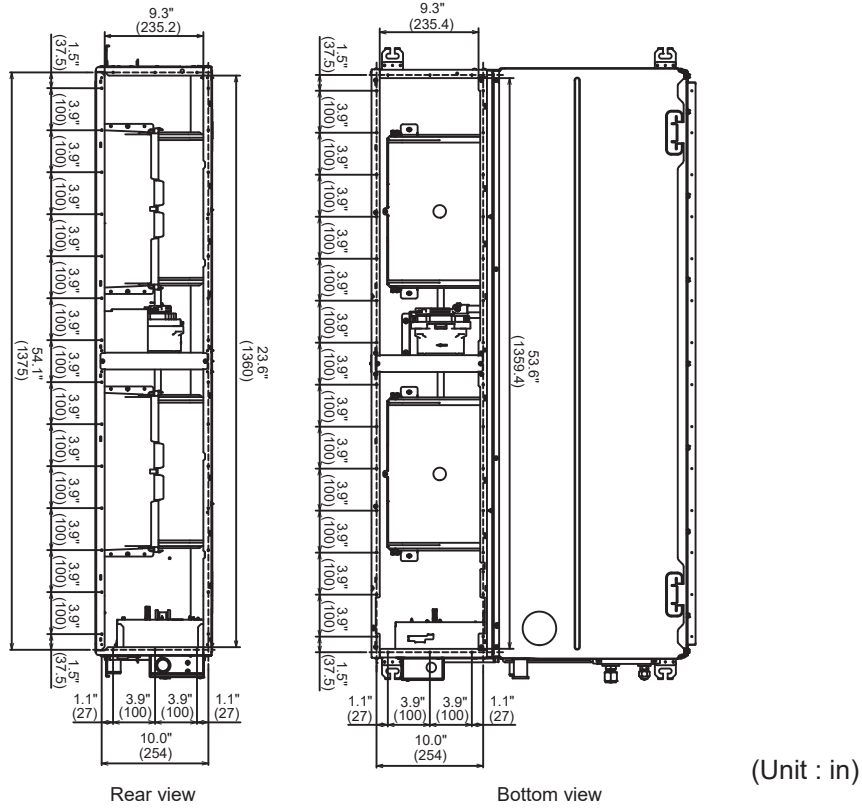

Space required for installation and servicing

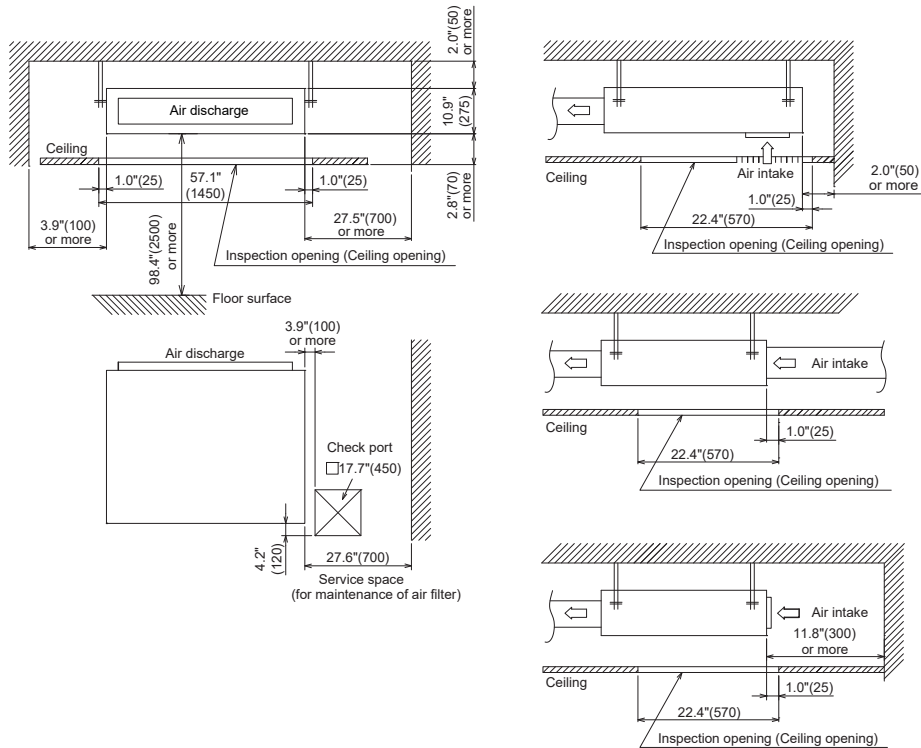

3. Center of gravity

Model name	X (in)	Y (in)	Z (in)	Total weight (lbs)
MMD-AP0076BHPUL	13.7	15.2	5.6	56
MMD-AP0096BHPUL				
MMD-AP0126BHPUL				
MMD-AP0156BHPUL	21.1	15.2	5.6	73
MMD-AP0186BHPUL				
MMD-AP0216BHPUL	29.3	15.2	5.6	93
MMD-AP0246BHPUL				
MMD-AP0306BHPUL				
MMD-AP0366BHPUL				
MMD-AP0426BHPUL				
MMD-AP0486BHPUL				
MMD-AP0546BHPUL				

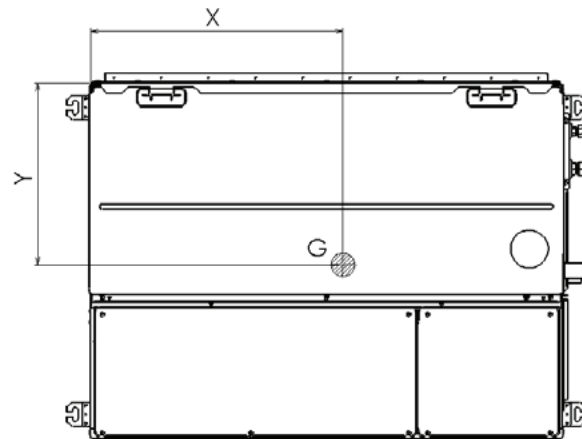
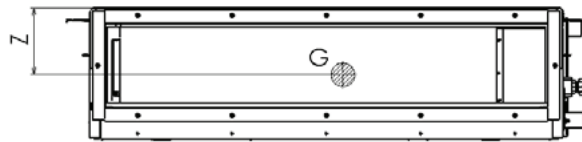

4. Piping diagram

MMMD-AP0__*6BHPUL (*07 / 09 / 12 / 15 / 18 / 21 / 24 / 30 / 36 / 42 / 48 / 54)

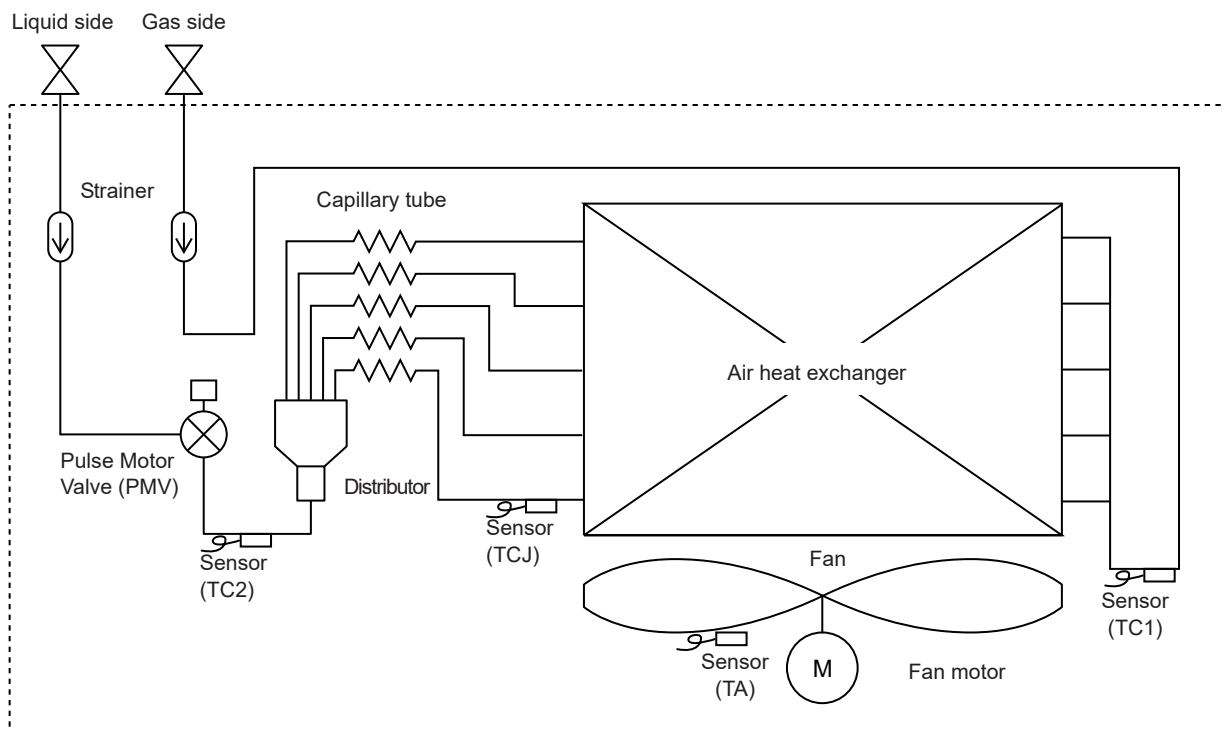

Functional part name		Functional outline
Pulse Motor Valve	PMV	(Connector CN082 (6P): Blue) 1) Controls super heat in cooling operation 2) Controls sub cool in heating operation 3) Recovers refrigerant oil in cooling operation 4) Recovers refrigerant oil in heating operation
Temp. sensor	1. TA	(Connector CN104 (2P): Yellow) 1) Detects indoor suction temperature
	2. TC1	(Connector CN100 (3P): Brown) 1) Controls PMV super heat in cooling operation
	3. TC2	(Connector CN101 (2P): Black) 1) Controls PMV sub cool in heating operation
	4. TCJ	(Connector CN102 (2P): Red) 1) Controls PMV super heat in cooling operation

5. Wiring diagram

MMMD-AP0__*6BHPUL (*07 / 09 / 12 / 15 / 18 / 21 / 24 / 30 / 36 / 42 / 48 / 54)

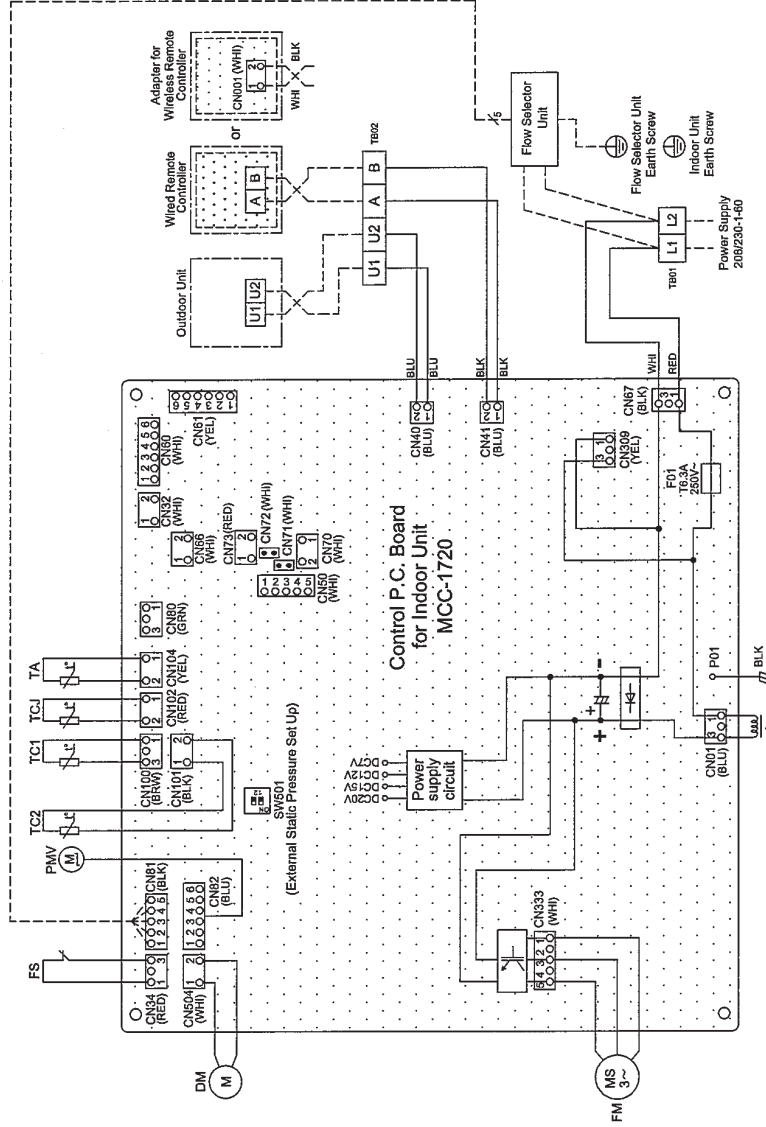

Color Indication

RED : Red
 WHI : White
 YEL : Yellow
 BLU : Blue
 BLK : Black
 GRN : Green
 BRW : Brown

Symbol	Parts name
CN**	Connector
DM	Drain Pump Motor
F01,02	Fuse
FM	Fan Motor
PMV	Pulse Motor Valve
FS	Float Switch
L	Reactor
TA	Indoor Temp Sensor
TB01,TB02	Terminal Block
TC1,TC2,TCJ	Temp Sensor

1. Broken line Indicate the wiring at site. Long dashed short dashed line indicate the accessories.
2. □ □ □ indicates the terminal block.
 □ □ □ indicates the connection terminal.
3. ⊕ indicates the connector on the control P.C. board.
 ⊕ indicates the protection ground.
4. □ □ □ □ □ indicates the control P.C. board.

6. Electrical current characteristics

Type	Model name	Normal Voltage (V-Ph-Hz)	Voltage Range (V)		FLA	MCA	MOCP
			Min.	Max.	A	A	A
Medium Static Pressure Duct Type	MMD-AP0076BHPUL	208/230-1-60	187	253	0.73	0.91	15
	MMD-AP0096BHPUL	208/230-1-60	187	253	0.88	1.10	15
	MMD-AP0126BHPUL	208/230-1-60	187	253	0.88	1.10	15
	MMD-AP0156BHPUL	208/230-1-60	187	253	1.53	1.91	15
	MMD-AP0186BHPUL	208/230-1-60	187	253	1.53	1.91	15
	MMD-AP0216BHPUL	208/230-1-60	187	253	1.78	2.23	15
	MMD-AP0246BHPUL	208/230-1-60	187	253	1.78	2.23	15
	MMD-AP0306BHPUL	208/230-1-60	187	253	1.85	2.31	15
	MMD-AP0366BHPUL	208/230-1-60	187	253	2.71	3.39	15
	MMD-AP0426BHPUL	208/230-1-60	187	253	2.71	3.39	15
	MMD-AP0486BHPUL	208/230-1-60	187	253	2.85	3.56	15
MMD-AP0546BHPUL	208/230-1-60	187	253	2.85	3.56	15	

MCA : Minimum Circuit (Amps)

FLA : Full load (Amps)

MOCP : Maximum Overcurrent Protection (Amps)

7. Sensible capacity table

Medium static pressure duct (MMD-AP__6BHPUL)

unit size	outdoor air temp. °FDB	Indoor air temp.													
		59 °FWB		61 °FWB		64 °FWB		67 °FWB		68 °FWB		72 °FWB		75 °FWB	
		71 °FDB	71 °FDB	73 °FDB	73 °FDB	77 °FDB	77 °FDB	80 °FDB	80 °FDB	82 °FDB	82 °FDB	86 °FDB	86 °FDB	90 °FDB	90 °FDB
	TC	SHC	TC	SHC	TC	SHC	TC	SHC	TC	SHC	TC	SHC	TC	SHC	
007	50	6380	5070	6680	5220	7100	5430	7500	5600	7630	5620	8110	5540	8450	5340
	54	6380	5070	6680	5220	7100	5430	7500	5600	7630	5620	8110	5540	8450	5340
	57	6380	5070	6680	5220	7100	5430	7500	5600	7630	5620	8110	5540	8450	5340
	61	6380	5070	6680	5220	7100	5430	7500	5600	7630	5620	8110	5540	8450	5340
	64	6380	5070	6680	5220	7100	5430	7500	5600	7630	5620	8110	5540	8450	5340
	68	6380	5070	6680	5220	7100	5430	7500	5600	7630	5620	8110	5540	8450	5340
	70	6380	5070	6680	5220	7100	5430	7500	5600	7630	5620	8110	5540	8450	5340
	73	6380	5070	6680	5220	7100	5430	7500	5600	7630	5620	8110	5540	8450	5340
	77	6380	5070	6680	5220	7100	5430	7500	5600	7630	5620	8110	5540	8450	5340
	81	6380	5070	6680	5220	7100	5430	7500	5600	7630	5620	8110	5540	8450	5340
	84	6380	5070	6680	5220	7100	5430	7500	5600	7630	5620	8110	5540	8450	5340
	88	6380	5070	6680	5220	7100	5430	7500	5600	7630	5620	8110	5540	8450	5340
	91	6380	5070	6680	5220	7100	5430	7500	5600	7630	5620	8110	5540	8450	5340
95	6380	5070	6680	5220	7100	5430	7500	5600	7630	5620	8110	5540	8450	5340	
99	6190	4920	6490	5070	6890	5270	7280	5440	7410	5460	7870	5380	8200	5190	
102	6050	4810	6330	4950	6730	5150	7110	5310	7230	5330	7690	5250	8010	5060	
009	50	8090	6440	8460	6610	9000	6890	9500	7100	9660	7120	10270	7030	10700	6770
	54	8090	6440	8460	6610	9000	6890	9500	7100	9660	7120	10270	7030	10700	6770
	57	8090	6440	8460	6610	9000	6890	9500	7100	9660	7120	10270	7030	10700	6770
	61	8090	6440	8460	6610	9000	6890	9500	7100	9660	7120	10270	7030	10700	6770
	64	8090	6440	8460	6610	9000	6890	9500	7100	9660	7120	10270	7030	10700	6770
	68	8090	6440	8460	6610	9000	6890	9500	7100	9660	7120	10270	7030	10700	6770
	70	8090	6440	8460	6610	9000	6890	9500	7100	9660	7120	10270	7030	10700	6770
	73	8090	6440	8460	6610	9000	6890	9500	7100	9660	7120	10270	7030	10700	6770
	77	8090	6440	8460	6610	9000	6890	9500	7100	9660	7120	10270	7030	10700	6770
	81	8090	6440	8460	6610	9000	6890	9500	7100	9660	7120	10270	7030	10700	6770
	84	8090	6440	8460	6610	9000	6890	9500	7100	9660	7120	10270	7030	10700	6770
	88	8090	6440	8460	6610	9000	6890	9500	7100	9660	7120	10270	7030	10700	6770
	91	8090	6440	8460	6610	9000	6890	9500	7100	9660	7120	10270	7030	10700	6770
95	8090	6440	8460	6610	9000	6890	9500	7100	9660	7120	10270	7030	10700	6770	
99	7860	6250	8210	6420	8740	6690	9220	6890	9380	6910	9970	6830	10390	6570	
102	7670	6110	8020	6270	8530	6530	9010	6730	9160	6750	9740	6660	10140	6420	
012	50	10210	8160	10690	8390	11360	8720	12000	9000	12210	9030	12980	8910	13510	8580
	54	10210	8160	10690	8390	11360	8720	12000	9000	12210	9030	12980	8910	13510	8580
	57	10210	8160	10690	8390	11360	8720	12000	9000	12210	9030	12980	8910	13510	8580
	61	10210	8160	10690	8390	11360	8720	12000	9000	12210	9030	12980	8910	13510	8580
	64	10210	8160	10690	8390	11360	8720	12000	9000	12210	9030	12980	8910	13510	8580
	68	10210	8160	10690	8390	11360	8720	12000	9000	12210	9030	12980	8910	13510	8580
	70	10210	8160	10690	8390	11360	8720	12000	9000	12210	9030	12980	8910	13510	8580
	73	10210	8160	10690	8390	11360	8720	12000	9000	12210	9030	12980	8910	13510	8580
	77	10210	8160	10690	8390	11360	8720	12000	9000	12210	9030	12980	8910	13510	8580
	81	10210	8160	10690	8390	11360	8720	12000	9000	12210	9030	12980	8910	13510	8580
	84	10210	8160	10690	8390	11360	8720	12000	9000	12210	9030	12980	8910	13510	8580
	88	10210	8160	10690	8390	11360	8720	12000	9000	12210	9030	12980	8910	13510	8580
	91	10210	8160	10690	8390	11360	8720	12000	9000	12210	9030	12980	8910	13510	8580
95	10210	8160	10690	8390	11360	8720	12000	9000	12210	9030	12980	8910	13510	8580	
99	9910	7920	10380	8150	11030	8470	11650	8740	11860	8770	12600	8650	13120	8330	
102	9680	7740	10130	7950	10770	8270	11380	8530	11580	8560	12310	8450	12810	8130	
015	50	13110	10520	13710	10800	14580	11240	15400	11600	15660	11630	16660	11490	17340	11050
	54	13110	10520	13710	10800	14580	11240	15400	11600	15660	11630	16660	11490	17340	11050
	57	13110	10520	13710	10800	14580	11240	15400	11600	15660	11630	16660	11490	17340	11050
	61	13110	10520	13710	10800	14580	11240	15400	11600	15660	11630	16660	11490	17340	11050
	64	13110	10520	13710	10800	14580	11240	15400	11600	15660	11630	16660	11490	17340	11050
	68	13110	10520	13710	10800	14580	11240	15400	11600	15660	11630	16660	11490	17340	11050
	70	13110	10520	13710	10800	14580	11240	15400	11600	15660	11630	16660	11490	17340	11050
	73	13110	10520	13710	10800	14580	11240	15400	11600	15660	11630	16660	11490	17340	11050
	77	13110	10520	13710	10800	14580	11240	15400	11600	15660	11630	16660	11490	17340	11050
	81	13110	10520	13710	10800	14580	11240	15400	11600	15660	11630	16660	11490	17340	11050
	84	13110	10520	13710	10800	14580	11240	15400	11600	15660	11630	16660	11490	17340	11050
	88	13110	10520	13710	10800	14580	11240	15400	11600	15660	11630	16660	11490	17340	11050
	91	13110	10520	13710	10800	14580	11240	15400	11600	15660	11630	16660	11490	17340	11050
95	13110	10520	13710	10800	14580	11240	15400	11600	15660	11630	16660	11490	17340	11050	
99	12730	10210	13310	10490	14160	10910	14950	11260	15210	11290	16180	11160	16840	10730	
102	12430	9970	13000	10240	13820	10660	14600	11000	14850	11030	15790	10890	16440	10480	

TC: Total Capacity [Btu/h]
SHC: Sensible Heat Capacity [Btu/h]

Medium static pressure duct (MMD-AP__6BHPUL)

unit size	outdoor air temp. °FDB	In door air temp.													
		59 °FDB		61 °FDB		64 °FDB		67 °FDB		68 °FDB		72 °FDB		75 °FDB	
		71 °FDB	73 °FDB	77 °FDB	80 °FDB	82 °FDB	86 °FDB	90 °FDB							
		TC	SHC	TC	SHC	TC	SHC	TC	SHC	TC	SHC	TC	SHC	TC	SHC
018	50	15320	12240	16030	12580	17040	13090	18000	13500	18310	13540	19470	13370	20270	12870
	54	15320	12240	16030	12580	17040	13090	18000	13500	18310	13540	19470	13370	20270	12870
	57	15320	12240	16030	12580	17040	13090	18000	13500	18310	13540	19470	13370	20270	12870
	61	15320	12240	16030	12580	17040	13090	18000	13500	18310	13540	19470	13370	20270	12870
	64	15320	12240	16030	12580	17040	13090	18000	13500	18310	13540	19470	13370	20270	12870
	68	15320	12240	16030	12580	17040	13090	18000	13500	18310	13540	19470	13370	20270	12870
	70	15320	12240	16030	12580	17040	13090	18000	13500	18310	13540	19470	13370	20270	12870
	73	15320	12240	16030	12580	17040	13090	18000	13500	18310	13540	19470	13370	20270	12870
	77	15320	12240	16030	12580	17040	13090	18000	13500	18310	13540	19470	13370	20270	12870
	81	15320	12240	16030	12580	17040	13090	18000	13500	18310	13540	19470	13370	20270	12870
	84	15320	12240	16030	12580	17040	13090	18000	13500	18310	13540	19470	13370	20270	12870
	88	15320	12240	16030	12580	17040	13090	18000	13500	18310	13540	19470	13370	20270	12870
91	15320	12240	16030	12580	17040	13090	18000	13500	18310	13540	19470	13370	20270	12870	
95	15320	12240	16030	12580	17040	13090	18000	13500	18310	13540	19470	13370	20270	12870	
99	14880	11890	15570	12220	16550	12710	17480	13110	17780	13150	18910	12980	19680	12500	
102	14520	11600	15200	11930	16150	12410	17060	12800	17360	12840	18460	12670	19220	12200	
021	50	17240	14010	19070	14920	20370	15850	21000	15800	21630	15800	22890	15650	23940	15290
	54	17240	14010	19070	14920	20370	15850	21000	15800	21630	15800	22890	15650	23940	15290
	57	17240	14010	19070	14920	20370	15850	21000	15800	21630	15800	22890	15650	23940	15290
	61	17240	14010	19070	14920	20370	15850	21000	15800	21630	15800	22890	15650	23940	15290
	64	17240	14010	19070	14920	20370	15850	21000	15800	21630	15800	22890	15650	23940	15290
	68	17240	14010	19070	14920	20370	15850	21000	15800	21630	15800	22890	15650	23940	15290
	70	17240	14010	19070	14920	20370	15850	21000	15800	21630	15800	22890	15650	23940	15290
	73	17240	14010	19070	14920	20370	15850	21000	15800	21630	15800	22890	15650	23940	15290
	77	17240	14010	19070	14920	20370	15850	21000	15800	21630	15800	22890	15650	23940	15290
	81	17240	14010	19070	14920	20370	15850	21000	15800	21630	15800	22890	15650	23940	15290
	84	17240	14010	19070	14920	20370	15850	21000	15800	21630	15800	22890	15650	23940	15290
	88	17240	14010	19070	14920	20370	15850	21000	15800	21630	15800	22890	15650	23940	15290
91	17240	14010	19070	14920	20370	15850	21000	15800	21630	15800	22890	15650	23940	15290	
95	17240	14010	19070	14920	20370	15850	21000	15800	21630	15800	22890	15650	23940	15290	
99	16740	13600	18520	14490	19780	15390	20390	15340	21000	15340	22230	15200	23250	14850	
102	16340	13280	18080	14140	19310	15030	19910	14980	20510	14980	21700	14840	22700	14490	
024	50	19704	15960	21792	16998	23280	18054	24000	18000	24720	17999	26160	17833	27360	17420
	54	19704	15960	21792	16998	23280	18054	24000	18000	24720	17999	26160	17833	27360	17420
	57	19704	15960	21792	16998	23280	18054	24000	18000	24720	17999	26160	17833	27360	17420
	61	19704	15960	21792	16998	23280	18054	24000	18000	24720	17999	26160	17833	27360	17420
	64	19704	15960	21792	16998	23280	18054	24000	18000	24720	17999	26160	17833	27360	17420
	68	19704	15960	21792	16998	23280	18054	24000	18000	24720	17999	26160	17833	27360	17420
	70	19704	15960	21792	16998	23280	18054	24000	18000	24720	17999	26160	17833	27360	17420
	73	19704	15960	21792	16998	23280	18054	24000	18000	24720	17999	26160	17833	27360	17420
	77	19704	15960	21792	16998	23280	18054	24000	18000	24720	17999	26160	17833	27360	17420
	81	19704	15960	21792	16998	23280	18054	24000	18000	24720	17999	26160	17833	27360	17420
	84	19704	15960	21792	16998	23280	18054	24000	18000	24720	17999	26160	17833	27360	17420
	88	19704	15960	21792	16998	23280	18054	24000	18000	24720	17999	26160	17833	27360	17420
91	19704	15960	21792	16998	23280	18054	24000	18000	24720	17999	26160	17833	27360	17420	
95	19704	15960	21792	16998	23280	18054	24000	18000	24720	17999	26160	17833	27360	17420	
99	19133	15497	21160	16505	22605	17530	23304	17478	24003	17477	25401	17316	26567	16915	
102	18679	15130	20659	16114	22069	17115	22752	17064	23435	17063	24800	16906	25937	16515	
030	50	24630	19950	27240	21250	29100	22570	30000	22500	30900	22500	32700	22290	34200	21780
	54	24630	19950	27240	21250	29100	22570	30000	22500	30900	22500	32700	22290	34200	21780
	57	24630	19950	27240	21250	29100	22570	30000	22500	30900	22500	32700	22290	34200	21780
	61	24630	19950	27240	21250	29100	22570	30000	22500	30900	22500	32700	22290	34200	21780
	64	24630	19950	27240	21250	29100	22570	30000	22500	30900	22500	32700	22290	34200	21780
	68	24630	19950	27240	21250	29100	22570	30000	22500	30900	22500	32700	22290	34200	21780
	70	24630	19950	27240	21250	29100	22570	30000	22500	30900	22500	32700	22290	34200	21780
	73	24630	19950	27240	21250	29100	22570	30000	22500	30900	22500	32700	22290	34200	21780
	77	24630	19950	27240	21250	29100	22570	30000	22500	30900	22500	32700	22290	34200	21780
	81	24630	19950	27240	21250	29100	22570	30000	22500	30900	22500	32700	22290	34200	21780
	84	24630	19950	27240	21250	29100	22570	30000	22500	30900	22500	32700	22290	34200	21780
	88	24630	19950	27240	21250	29100	22570	30000	22500	30900	22500	32700	22290	34200	21780
91	24630	19950	27240	21250	29100	22570	30000	22500	30900	22500	32700	22290	34200	21780	
95	24630	19950	27240	21250	29100	22570	30000	22500	30900	22500	32700	22290	34200	21780	
99	23920	19370	26450	20630	28260	21920	29130	21850	30000	21850	31750	21640	33210	21150	
102	23350	18910	25820	20150	27590	21400	28440	21330	29290	21330	31000	21130	32420	20650	

TC: Total Capacity [Btu/h]
SHC: Sensible Heat Capacity [Btu/h]

Medium static pressure duct (MMD-AP__6BHPUL)

unit size	outdoor air temp. °FDB	indoor air temp.													
		59 °FWB 71 °FDB		61 °FWB 73 °FDB		64 °FWB 77 °FDB		67 °FWB 80 °FDB		68 °FWB 82 °FDB		72 °FWB 86 °FDB		75 °FWB 90 °FDB	
		TC	SHC	TC	SHC	TC	SHC	TC	SHC	TC	SHC	TC	SHC	TC	SHC
036	50	29560	23940	32690	25500	34920	27080	36000	27000	37080	27000	39240	26750	41040	26130
	54	29560	23940	32690	25500	34920	27080	36000	27000	37080	27000	39240	26750	41040	26130
	57	29560	23940	32690	25500	34920	27080	36000	27000	37080	27000	39240	26750	41040	26130
	61	29560	23940	32690	25500	34920	27080	36000	27000	37080	27000	39240	26750	41040	26130
	64	29560	23940	32690	25500	34920	27080	36000	27000	37080	27000	39240	26750	41040	26130
	68	29560	23940	32690	25500	34920	27080	36000	27000	37080	27000	39240	26750	41040	26130
	70	29560	23940	32690	25500	34920	27080	36000	27000	37080	27000	39240	26750	41040	26130
	73	29560	23940	32690	25500	34920	27080	36000	27000	37080	27000	39240	26750	41040	26130
	77	29560	23940	32690	25500	34920	27080	36000	27000	37080	27000	39240	26750	41040	26130
	81	29560	23940	32690	25500	34920	27080	36000	27000	37080	27000	39240	26750	41040	26130
	84	29560	23940	32690	25500	34920	27080	36000	27000	37080	27000	39240	26750	41040	26130
	88	29560	23940	32690	25500	34920	27080	36000	27000	37080	27000	39240	26750	41040	26130
	91	29560	23940	32690	25500	34920	27080	36000	27000	37080	27000	39240	26750	41040	26130
95	29560	23940	32690	25500	34920	27080	36000	27000	37080	27000	39240	26750	41040	26130	
99	28700	23250	31740	24760	33910	26290	34960	26220	36000	26220	38100	25970	39850	25370	
102	28200	22700	30990	24170	33100	25670	34130	25600	35150	25600	37200	25360	38910	24770	
042	50	34480	27930	38140	29750	40740	31590	42000	31500	43260	31500	45780	31210	47880	30490
	54	34480	27930	38140	29750	40740	31590	42000	31500	43260	31500	45780	31210	47880	30490
	57	34480	27930	38140	29750	40740	31590	42000	31500	43260	31500	45780	31210	47880	30490
	61	34480	27930	38140	29750	40740	31590	42000	31500	43260	31500	45780	31210	47880	30490
	64	34480	27930	38140	29750	40740	31590	42000	31500	43260	31500	45780	31210	47880	30490
	68	34480	27930	38140	29750	40740	31590	42000	31500	43260	31500	45780	31210	47880	30490
	70	34480	27930	38140	29750	40740	31590	42000	31500	43260	31500	45780	31210	47880	30490
	73	34480	27930	38140	29750	40740	31590	42000	31500	43260	31500	45780	31210	47880	30490
	77	34480	27930	38140	29750	40740	31590	42000	31500	43260	31500	45780	31210	47880	30490
	81	34480	27930	38140	29750	40740	31590	42000	31500	43260	31500	45780	31210	47880	30490
	84	34480	27930	38140	29750	40740	31590	42000	31500	43260	31500	45780	31210	47880	30490
	88	34480	27930	38140	29750	40740	31590	42000	31500	43260	31500	45780	31210	47880	30490
	91	34480	27930	38140	29750	40740	31590	42000	31500	43260	31500	45780	31210	47880	30490
95	34480	27930	38140	29750	40740	31590	42000	31500	43260	31500	45780	31210	47880	30490	
99	33480	27120	37030	28890	39560	30670	40780	30590	42010	30590	44450	30300	46490	29610	
102	32690	26480	36160	28200	38620	29950	39820	29860	41010	29860	43400	29590	45390	28900	
048	50	39410	31920	43580	33990	46560	36110	48000	36000	49440	36000	52320	35670	54720	34840
	54	39410	31920	43580	33990	46560	36110	48000	36000	49440	36000	52320	32810	54720	34840
	57	39410	31920	43580	33990	46560	36110	48000	36000	49440	36000	52320	32810	54720	34840
	61	39410	31920	43580	33990	46560	36110	48000	36000	49440	36000	52320	32810	54720	34840
	64	39410	31920	43580	33990	46560	36110	48000	36000	49440	36000	52320	32810	54720	34840
	68	39410	31920	43580	33990	46560	36110	48000	36000	49440	36000	52320	32810	54720	34840
	70	39410	31920	43580	33990	46560	36110	48000	36000	49440	36000	52320	32810	54720	34840
	73	39410	31920	43580	33990	46560	36110	48000	36000	49440	36000	52320	32810	54720	34840
	77	39410	31920	43580	33990	46560	36110	48000	36000	49440	36000	52320	32810	54720	34840
	81	39410	31920	43580	33990	46560	36110	48000	36000	49440	36000	52320	32810	54720	34840
	84	39410	31920	43580	33990	46560	36110	48000	36000	49440	36000	52320	32810	54720	34840
	88	39410	31920	43580	33990	46560	36110	48000	36000	49440	36000	52320	32810	54720	34840
	91	39410	31920	43580	33990	46560	36110	48000	36000	49440	36000	52320	32810	54720	34840
95	39410	31920	43580	33990	46560	36110	48000	36000	49440	36000	52320	35670	54720	34840	
99	38270	30990	42320	33000	45210	35060	46610	34960	48010	34960	50800	34640	53130	33830	
102	37360	30260	41310	32220	44140	34230	45500	34130	46870	34130	49600	33820	51870	33030	
054	50	44330	35910	49030	38240	54000	40620	54000	40500	55620	40500	58860	40120	61560	39200
	54	44330	35910	49030	38240	54000	40620	54000	40500	55620	40500	58860	40120	61560	39200
	57	44330	35910	49030	38240	54000	40620	54000	40500	55620	40500	58860	40120	61560	39200
	61	44330	35910	49030	38240	54000	40620	54000	40500	55620	40500	58860	40120	61560	39200
	64	44330	35910	49030	38240	54000	40620	54000	40500	55620	40500	58860	40120	61560	39200
	68	44330	35910	49030	38240	54000	40620	54000	40500	55620	40500	58860	40120	61560	39200
	70	44330	35910	49030	38240	54000	40620	54000	40500	55620	40500	58860	40120	61560	39200
	73	44330	35910	49030	38240	54000	40620	54000	40500	55620	40500	58860	40120	61560	39200
	77	44330	35910	49030	38240	54000	40620	54000	40500	55620	40500	58860	40120	61560	39200
	81	44330	35910	49030	38240	54000	40620	54000	40500	55620	40500	58860	40120	61560	39200
	84	44330	35910	49030	38240	54000	40620	54000	40500	55620	40500	58860	40120	61560	39200
	88	44330	35910	49030	38240	54000	40620	54000	40500	55620	40500	58860	40120	61560	39200
	91	44330	35910	49030	38240	54000	40620	54000	40500	55620	40500	58860	40120	61560	39200
95	44330	35910	49030	38240	52380	40620	54000	40500	55620	40500	58860	40120	61560	39200	
99	43040	34870	47610	37130	50860	39440	52430	39330	54010	39330	57150	38960	59770	38060	
102	42020	34040	46480	36250	49660	38510	51190	38390	52730	38390	55800	38030	58360	37160	

TC: Total Capacity [Btu/h]
SHC: Sensible Heat Capacity [Btu/h]

Heating capacity table

	Indoor air temp. °FDB					
Fahrenheit(°F)	62	65	68	70	72	75
Celsius(°C)	16.7	18.3	20	21.1	22.2	23.9
	Total capacity (TC) (kBtu/h)					
MMD-AP0076BHPUL	8.9	8.8	8.6	8.5	8.4	8.2
MMD-AP0096BHPUL	11.0	10.8	10.6	10.5	10.4	10.1
MMD-AP0126BHPUL	14.1	13.9	13.7	13.5	13.3	13.0
MMD-AP0156BHPUL	17.8	17.5	17.2	17.0	16.8	16.4
MMD-AP0186BHPUL	20.9	20.6	20.2	20.0	19.7	19.3
MMD-AP0216BHPUL	25.1	24.7	24.3	24.0	23.7	23.2
MMD-AP0246BHPUL	28.2	27.8	27.3	27.0	26.6	26.1
MMD-AP0306BHPUL	35.5	35.0	34.4	34.0	33.6	32.9
MMD-AP0366BHPUL	41.8	41.2	40.5	40.0	39.5	38.6
MMD-AP0426BHPUL	49.6	48.9	48.1	47.5	46.9	45.9
MMD-AP0486BHPUL	56.4	55.6	54.7	54.0	53.3	52.2
MMD-AP0546BHPUL	62.7	61.8	60.7	60.0	59.2	58.0

Notes: 1. These capacity tables can be used when selecting a VRF indoor unit. The actual capacity of the VRF system depends on factors such as the selected model of outdoor units, outdoor air temperature and piping length. Please confirm that the corrected capacity of the VRF system satisfies the required heat load.

Notes: 2. This is the capacity table of rated heating test condition of Outdoor 47°F Dry Bulb / 43°F Wet Bulb.

8. Fan characteristics

MMD-AP0076BHPUL

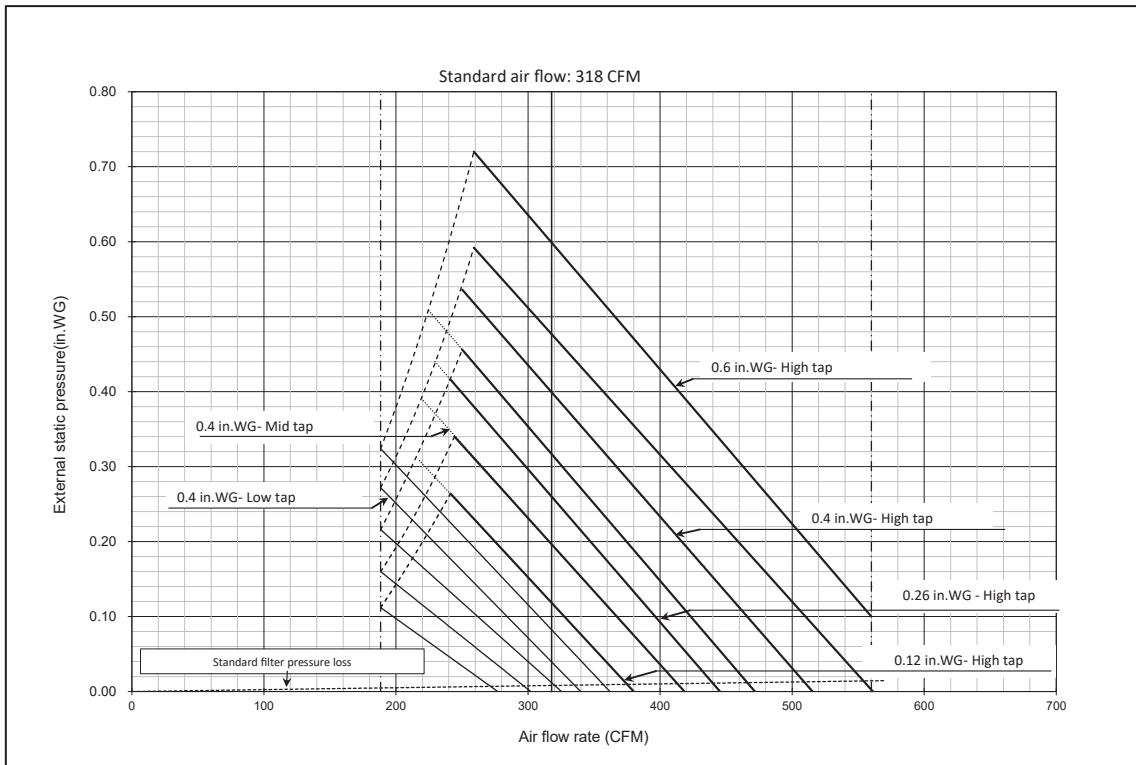

MMD-AP0096BHPUL / AP0126BHPUL

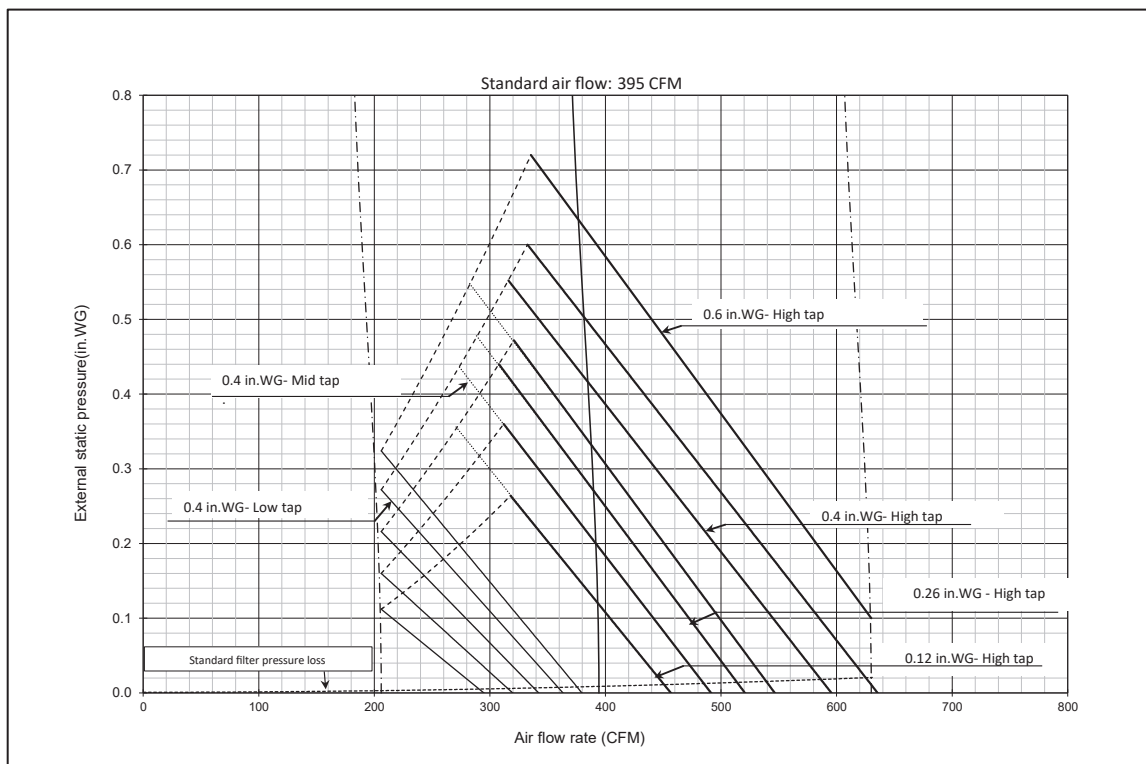

MMD-AP0156BHPUL

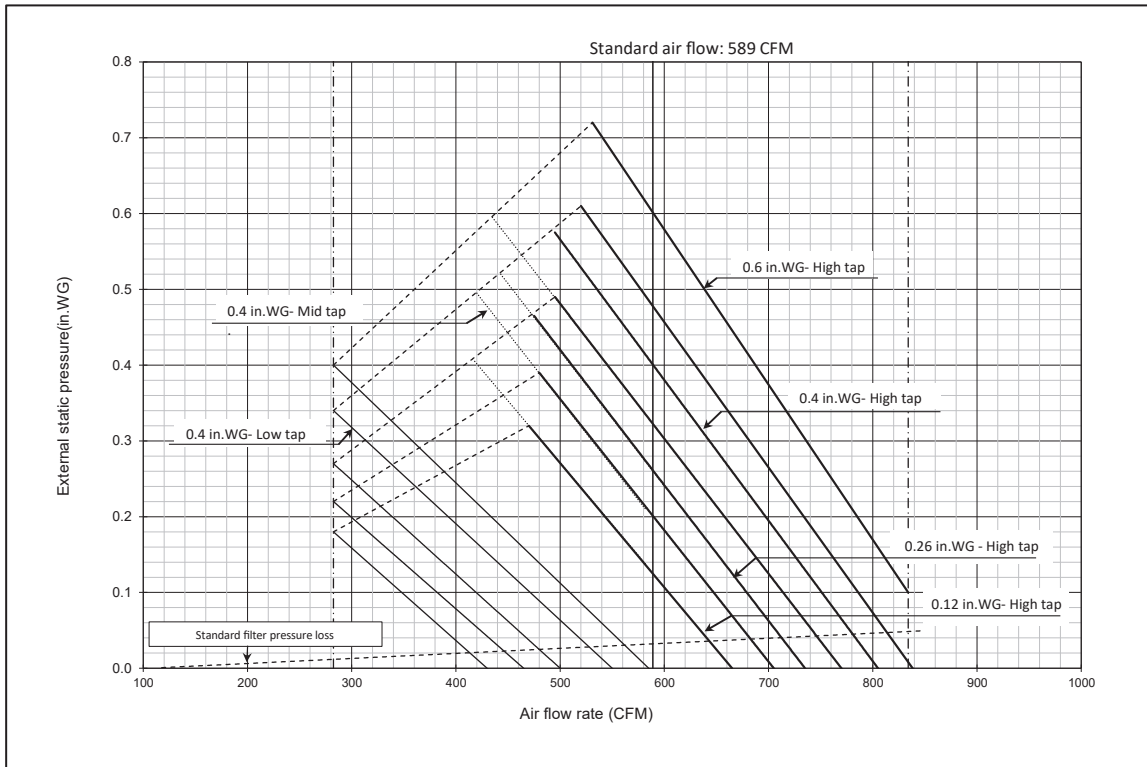

MMD-AP0186BHPUL

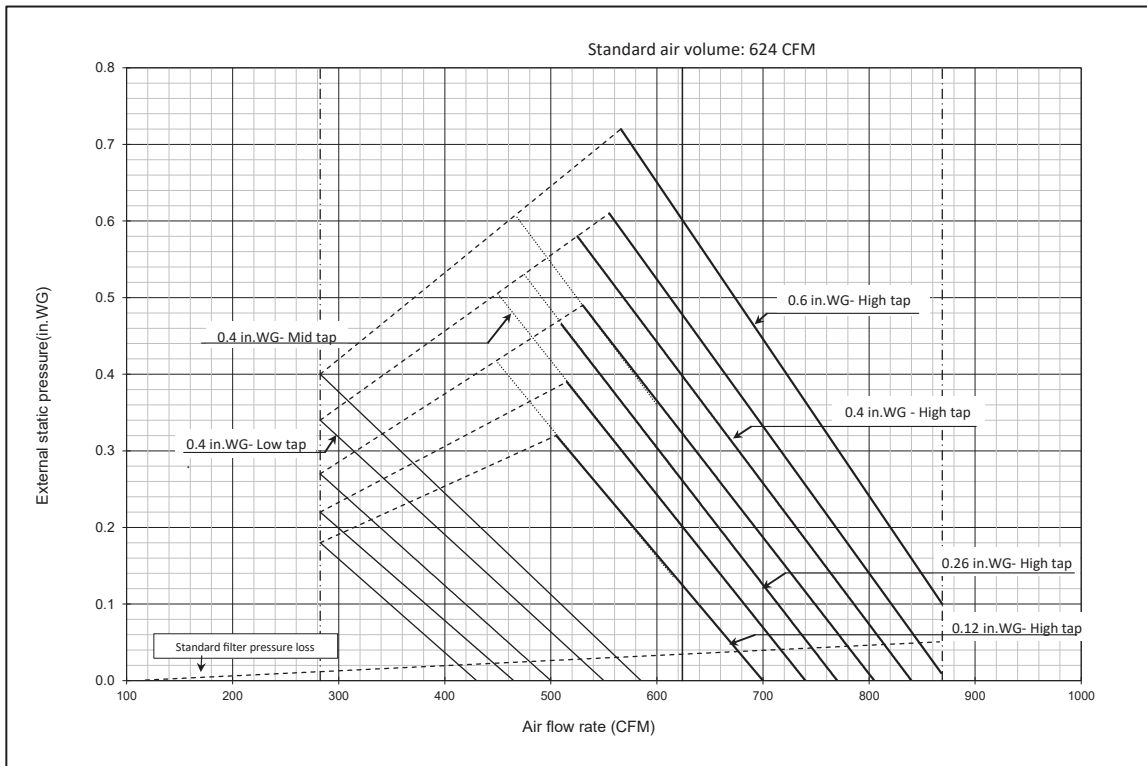

MMD-AP0216BHPUL / AP0246BHPUL

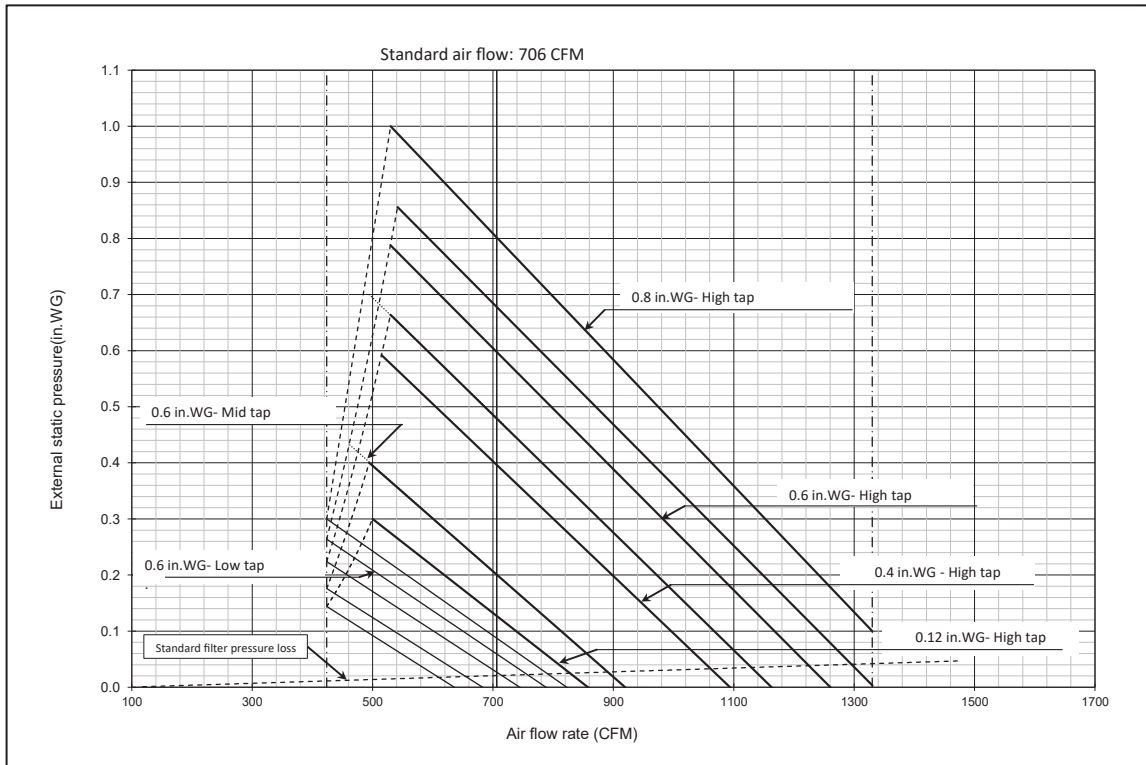

MMD-AP0306BHPUL

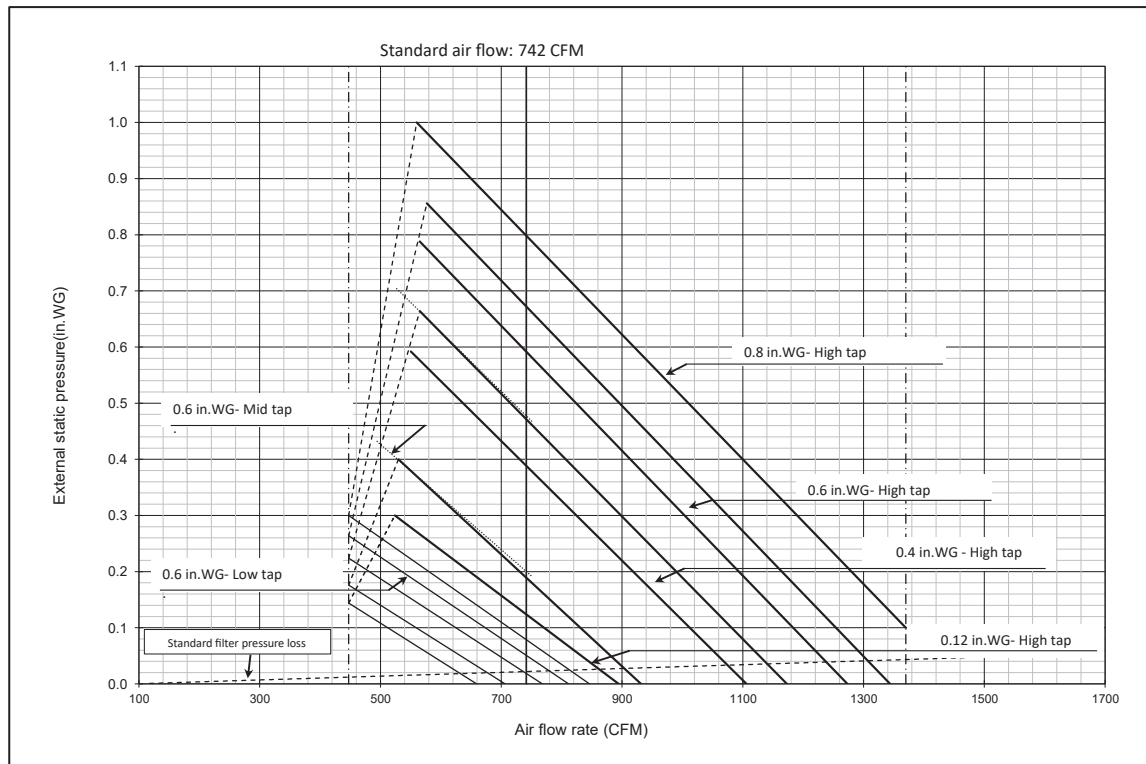

MMD-AP0366BHPUL / AP0426BHPUL

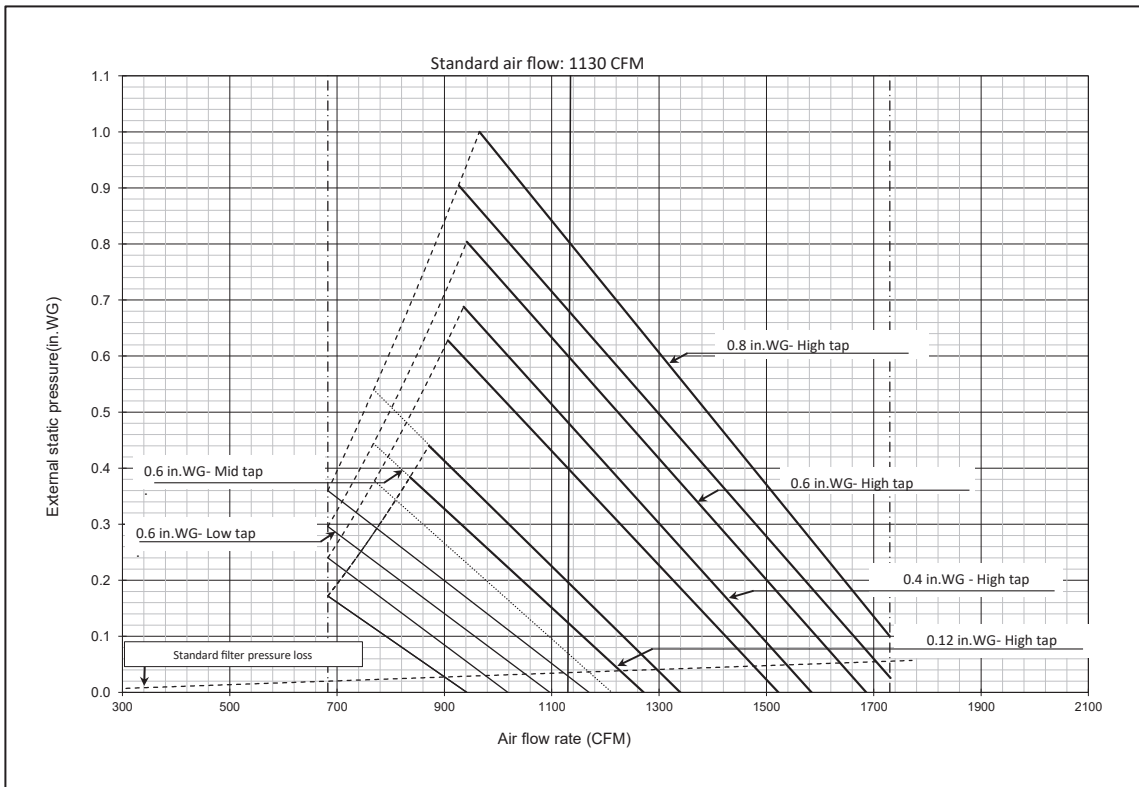

MMD-AP0486BHPUL / AP0546BHPUL

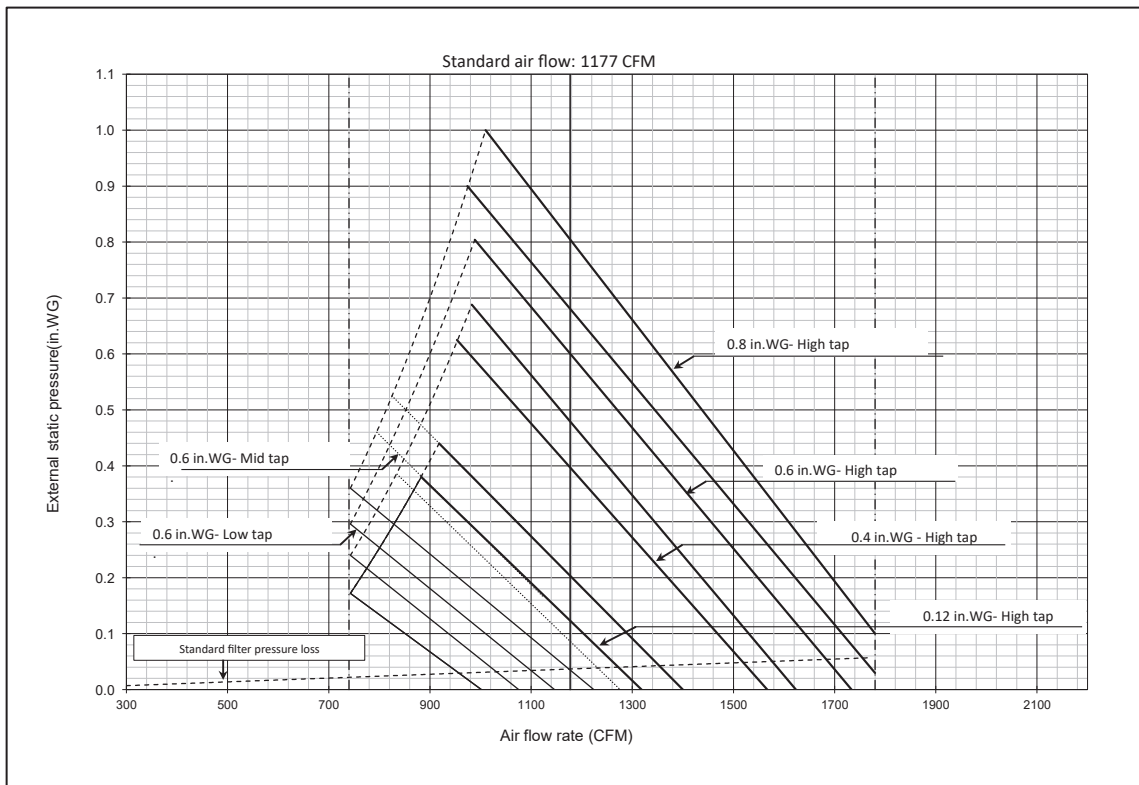

The concealed duct unit has 7 steps of static pressure (MMD-AP007 ~ 081* : 0.12 - 0.6 in.WG, MMD-AP021 ~ 056* : 0.12 - 0.8 in.WG) adjustment to meet the installation site requirements / conditions.

With these steps there are different speed fan taps associated to select correct air flow.

For meeting the site requirement / conditions, make sure the external static pressure and air flow are determined.

Plot the external static pressure and air flow on the below graph to determine the right speed fan step setting.

For example : Job site requirement is to deliver 400 CFM at 0.4 in.WG external static pressure. Using the below graph, external static pressure on vertical axis and air flow on horizontal axis, the star mark indicates the job site requirement.

The star mark is below 0.6 in.WG high speed fan tap line, which means the unit needs to be set to 0.6 in.WG external static pressure with high speed fan tap.

Please follow the process described in application controls of this manual for set up external static pressure.

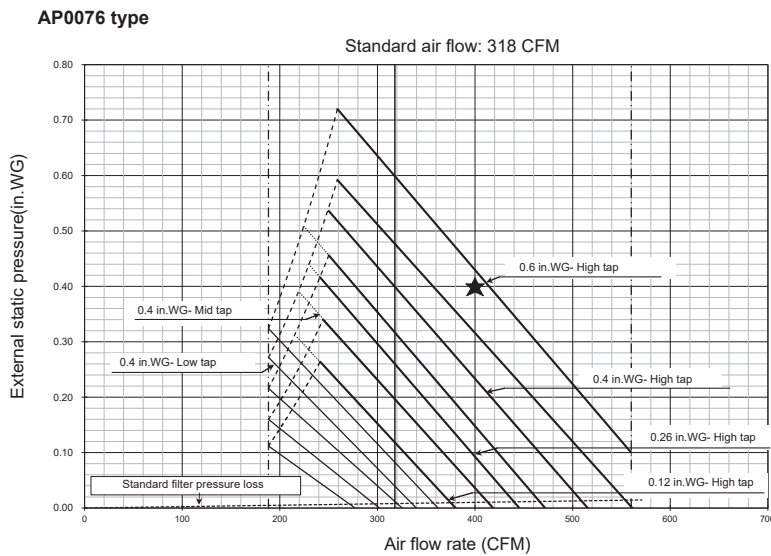

NOTE

Supply air CFM will follow the solid line fan curve shown in the above graph if there is any change in the external static pressure.

Supply air volume for medium and low fan speed tap is also set by remote controller. It will follow the dotted line fan curve in the graph.

9. Sound data

MMD-AP0076BHPUL

Fan tap	H	M	L
Sound pressure level (dB(A))	39	34	30

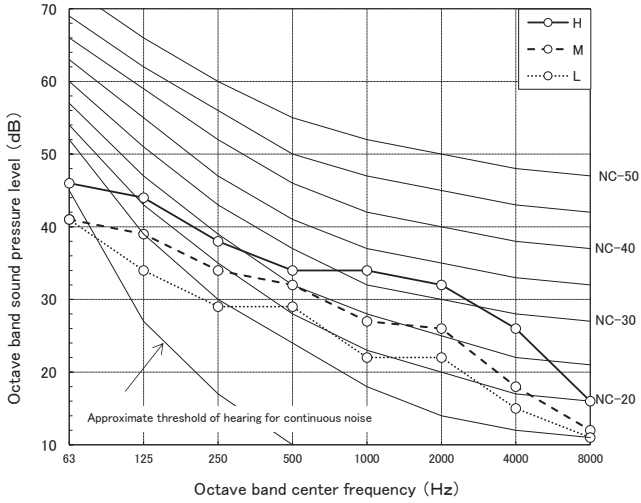

MMD-AP0096BHPUL / AP0126BHPUL

Fan tap	H	M	L
Sound pressure level (dB(A))	41	36	32

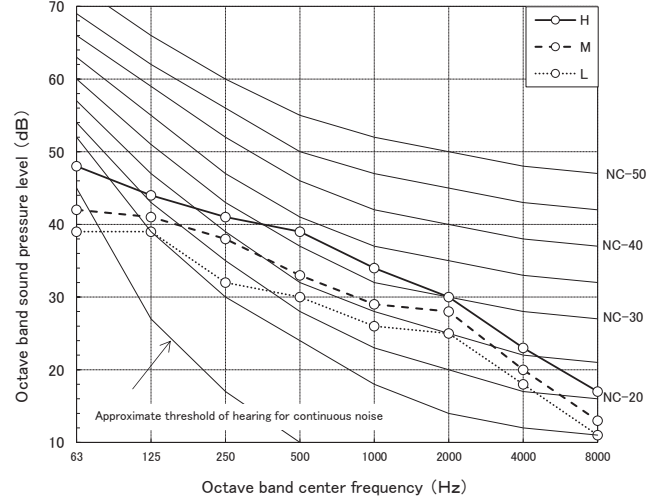

MMD-AP0156BHPUL

Fan tap	H	M	L
Sound pressure level (dB(A))	44	41	35

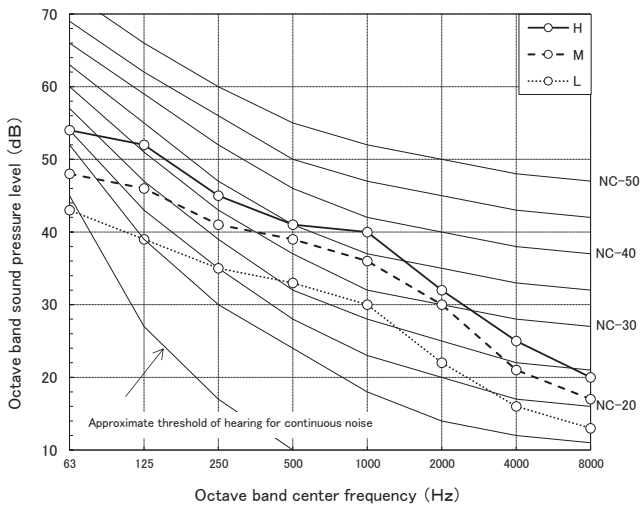

MMD-AP0186BHPUL

Fan tap	H	M	L
Sound pressure level (dB(A))	45	41	35

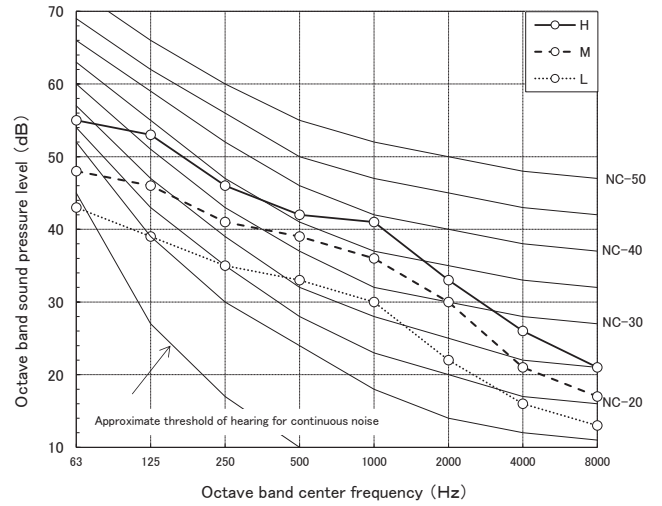

MMD-AP0216BHPUL / AP0246BHPUL

Fan tap	H	M	L
Sound pressure level (dB(A))	44	34	30

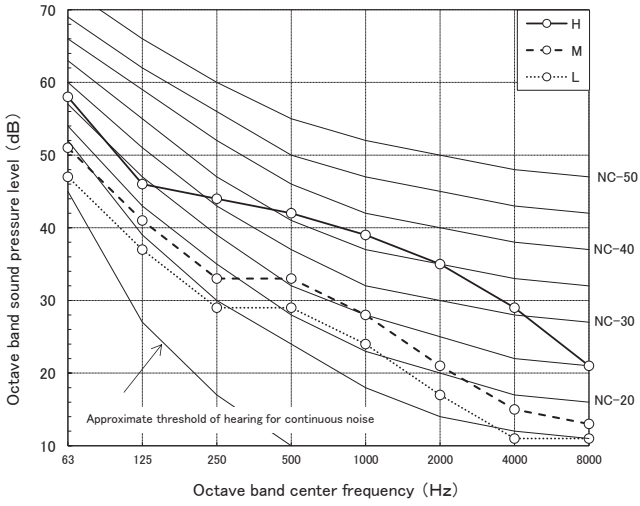

MMD-AP0306BHPUL

Fan tap	H	M	L
Sound pressure level (dB(A))	45	35	31

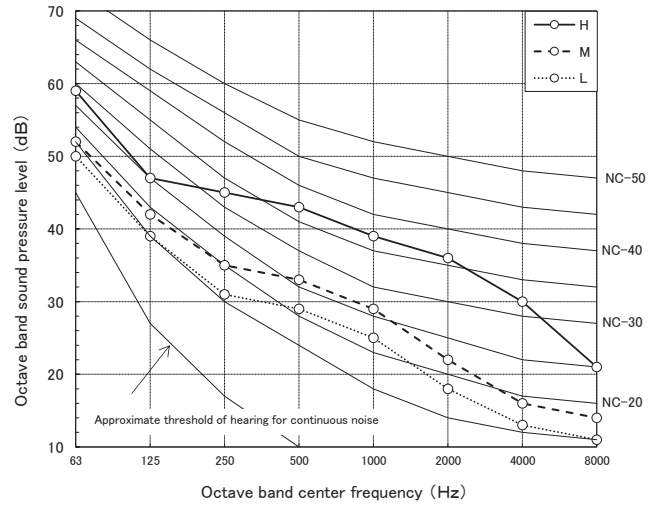

MMD-AP0366BHPUL / AP0426BHPUL

Fan tap	H	M	L
Sound pressure level (dB(A))	46	41	37

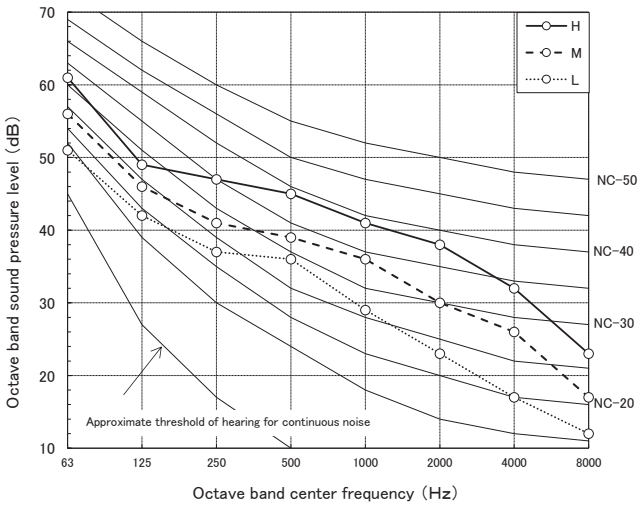

MMD-AP0486BHPUL / AP0546BHPUL

Fan tap	H	M	L
Sound pressure level (dB(A))	47	42	38

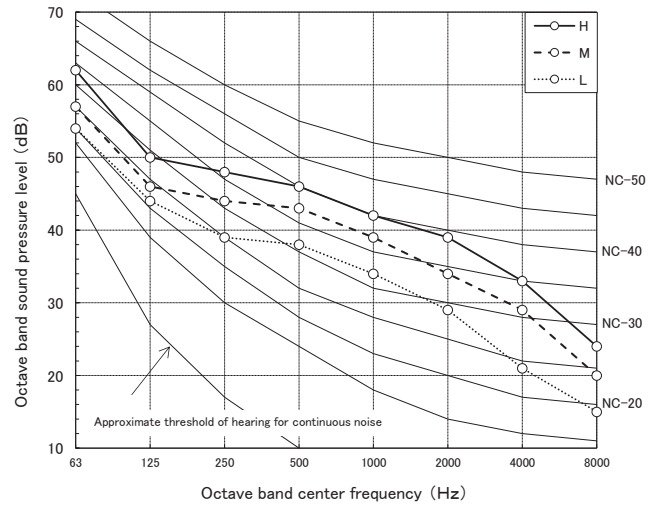

10. Accessories

Optional Parts	Model Name	Applicable FCU
Zoning duct flange	TCB-SF56C6BP-UL	MMD-AP0076/0096/0126BHPUL
	TCB-SF80C6BP-UL	MMD-AP0156/0186BHPUL
	TCB-SF160C6BP-UL	MMD-AP0216/0246/0306/0366BHPUL MMD-AP0426/0486/0546BHPUL
Auxiliary fresh air flange	TCB-FF151US-E	For Duct type

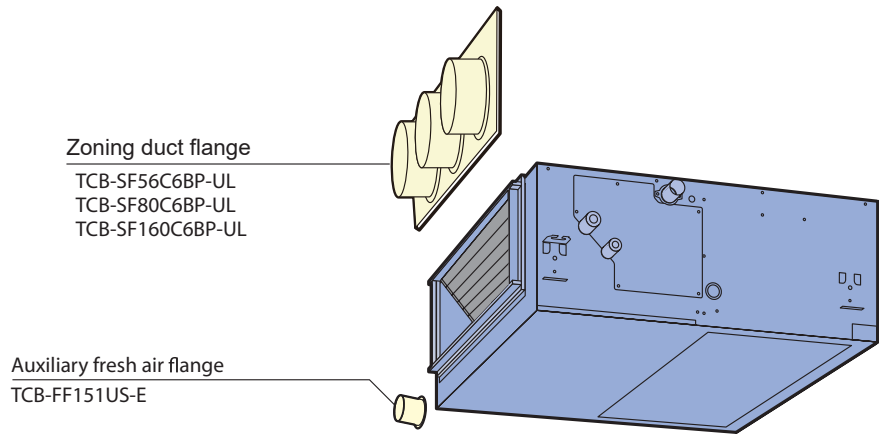

Appendix

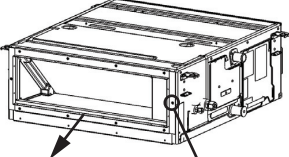
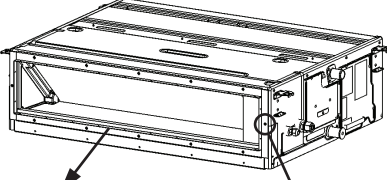
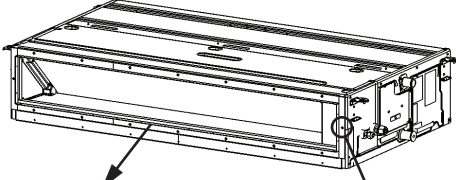
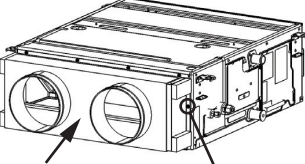
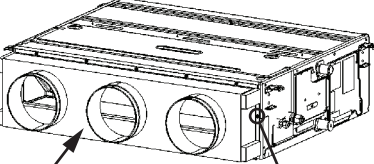
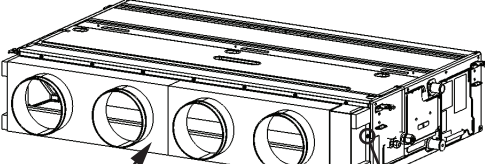
Zoning duct flange TCB-SF56C6BP-UL	Zoning duct flange TCB-SF80C6BP-UL	Zoning duct flange TCB-SF160C6BP-UL
 <p>Remove the square flange for duct</p> <p>Remove the screws. (10 parts)</p>	 <p>Remove the square flange for duct</p> <p>Remove the screws. (12 parts)</p>	 <p>Remove the square flange for duct</p> <p>Remove the screws. (16 parts)</p>
 <p>Attach the zoning duct flange</p> <p>Screws (10 parts)</p>	 <p>Attach the zoning duct flange</p> <p>Screws (12 parts)</p>	 <p>Attach the zoning duct flange</p> <p>Screws (12 parts)</p>

Remove screws on square flange for duct of indoor unit and attach the zoning duct flange with the screw.

External pressure loss characteristic

When you use these "Zoning duct flange" with Concealed Duct Type and High Static Pressure type, pressure-loss characteristics depends on Air Flow.

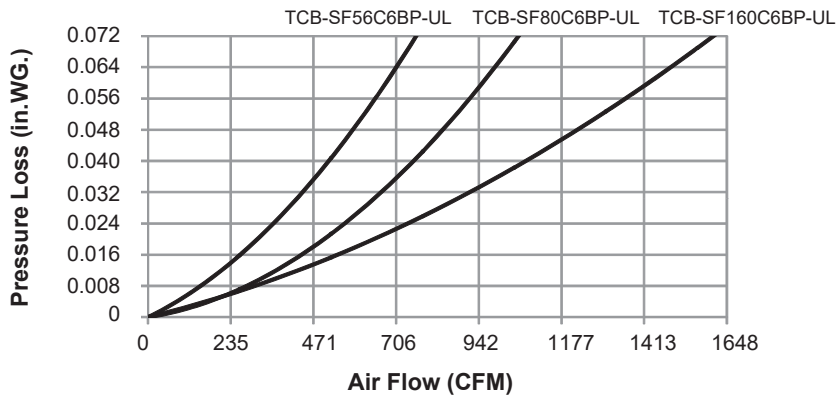

TOSHIBA CARRIER (THAILAND) CO.,LTD.

144/9 Moo 5, Bangkadi Industrial Park, Tivanon Road, Tambol Bangkadi,
Amphur Muang, Pathumthani 12000, Thailand

Copyright © 2020 TOSHIBA CARRIER (THAILAND), All Rights Reserved

Notice : Toshiba is committed to continuously improving its products to ensure the highest quality and reliability standard, and to meet local regulations and market requirements. All features and specifications are subject to change without prior notice.
