



Controls Operation and Troubleshooting

SAFETY CONSIDERATIONS	1
GENERAL	2
Abbreviations Used in This Manual	2
HARDWARE	2
Main Control Board	2
SIOB (Starfire Input/Output Board)	2
IOB (Input/Output Board)	2
Communication Cables	11
Sensors	11
Controls Outputs	11
USER INTERFACE	11
Web Connection	11
General Interface Features	12
CONTROL OPERATION	16
Start-Stop Control	16
Compressor Run Status	16
Chiller Start-Up Sequence	16
Chiller Shutdown Sequence	17
Refrigerant Lubrication Control	17
Control Points	18
Displaying Data Trends	26
Hydraulic Option	26
DIAGNOSTICS AND TROUBLESHOOTING	27
Alarm/Alert Codes	27
Displaying Alarms	27
Resetting Alarms	27
Event States	42
CONTROLLER SETTINGS	42
Unit IP Address	42
System Configuration	43
COMMUNICATION PROBLEMS	43
Hardware Problems	43
Web Interface Problems	43
Ethernet/IP Connection Problems	44
APPENDIX A — PIC6 SCREEN AND TABLE	
STRUCTURE	46
APPENDIX B — IOB AND HMI DIP SWITCH	
SETTINGS	82
APPENDIX C — INPUT/OUTPUT BOARD (IOB)	
STATUS INDICATORS	83
APPENDIX D — NETWORK CONFIGURATION	84

SAFETY CONSIDERATIONS

Installing, starting up, and servicing this equipment can be hazardous due to system pressures, electrical components, and equipment location (roof, elevated structures, etc.). Only trained, qualified installers and service mechanics should install, start up, and service this equipment. When working on this equipment,

observe precautions in the literature, and on tags, stickers, and labels attached to the equipment, and any other safety precautions that apply. Follow all safety codes. Wear safety glasses and work gloves. Use care in handling, rigging, and setting this equipment, and in handling all electrical components.

⚠ DANGER

ELECTRICAL SHOCK HAZARD

Failure to follow this warning will result in personal injury or death.

Before performing service or maintenance operations on unit, turn off main power switch to unit and install lock(s) and lockout tag(s). Ensure electrical service to rooftop unit agrees with voltage and amperage listed on the unit rating plate. Unit may have more than one power switch.

⚠ WARNING

Electrical currents cause components to get hot either temporarily or permanently and may cause burns. Handle power cable, electrical cables and conduits, terminal box covers, and motor frames with great care.

⚠ CAUTION

This unit uses a microprocessor control system. Do not short or jumper between terminations on circuit boards or modules; control or board failure may result.

Be aware of electrostatic discharge (static electricity) when handling or making contact with circuit boards or module connections. Always touch a chassis (grounded) part to dissipate body electrostatic charge before working inside control center.

Use extreme care when handling tools near boards and when connecting or disconnecting terminal plugs. Circuit boards can easily be damaged. Always hold boards by the edges and avoid touching components and connections.

This equipment uses, and can radiate, radio frequency energy. If not installed and used in accordance with the instruction manual, it may cause interference to radio communications. The PIC6 control boards have been tested and found to comply with the limits for a Class A computing device pursuant to International Standard in North America EN 61000-2/3 which are designed to provide reasonable protection against such interference when operated in a commercial environment. Operation of this equipment in a residential area is likely to cause interference, in which case the user, at his own expense, will be required to take whatever measures may be required to correct the interference.

Always store and transport replacement or defective boards in anti-static shipping bag.

GENERAL

This publication contains operation and troubleshooting information for PIC (Product Integrated Control) 6, a system for controlling 19DV semi-hermetic centrifugal liquid chillers. This publication is based on 19DVPIC6.

The PIC6 control system monitors and controls all operations of the chiller. The microprocessor control system matches the capacity of the chiller to the cooling load while providing state-of-the-art chiller protection. The system controls cooling load within the set point plus or minus the dead band by sensing the water or brine temperature and regulating the inlet guide vane via a mechanically linked actuator motor, and regulating VFD (variable frequency drive) speed of the compressor. The guide vane is a variable flow pre-whirl assembly that controls the refrigeration effect in the evaporator by regulating the amount of refrigerant vapor flow into the compressor. An increase in guide vane opening increases capacity. A decrease in guide vane opening decreases capacity. The microprocessor-based control center protects the chiller by monitoring the digital and analog inputs and executing capacity overrides or safety shut-downs as necessary.

The PIC6 control system also provides access to a Control Test function covering all outputs except compressor relay outputs.

NOTE: This software is shared between multiple product families and therefore not all points indicated in the tables are applicable to 19DV or 19XR as configured. For instance 19DV is not an oil lubricated machine, so any reference to oil in the software tables would not be applicable for 19DV.

Abbreviations Used in This Manual

The following abbreviations are used in this manual:

AWG	— American Wire Gage
CCM	— Chiller Control Module
CCN mode	— Operating mode: CCN
CCN	— Carrier Comfort Network®
DHCP	— Dynamic Host Configuration Protocol
DSH	— Discharge Superheat
EC	— Envelope Control (Hot Gas Bypass)
ECDW	— Entering Condenser Water
ECW	— Entering Chilled Water
EWT	— Entering Water Temperature
HGBP	— Hot Gas Bypass
HMI	— Human Machine Interface
I/O	— Input/Output
IOB	— Input/Output Board
LCDW	— Leaving Condenser Water
LCW	— Leaving Chilled Water
LED	— Light-Emitting Diode
LEN	— Local Equipment
MCB	— Main Control Board
NIC	— Network Interface Card
PIC	— Product Integrated Control
RLA	— Rated Load Amps
RTD	— Resistance Temperature Detector
SIOB	— Starfire Input/Output Board
TFT	— Thin Film Transistor
UI	— User Interface
VFD	— Variable Frequency Drive

HARDWARE

The PIC6 control system consists of one main control board, an input/output board (IOB) for purge control, and four IOB modules. All boards communicate via an internal Local Equipment Network (LEN) bus.

Main Control Board

The main control board is supplied from a 24 VAC supply reference to earth ground. In the event of a power supply interrupt, the unit restarts automatically without the need for an external command. However, any faults active when the supply is interrupted are saved, and may in certain cases prevent a circuit or unit from restarting. Figure 1 shows the main control interface and connectors.

PIC6

SIDE VIEW

BOTTOM VIEW

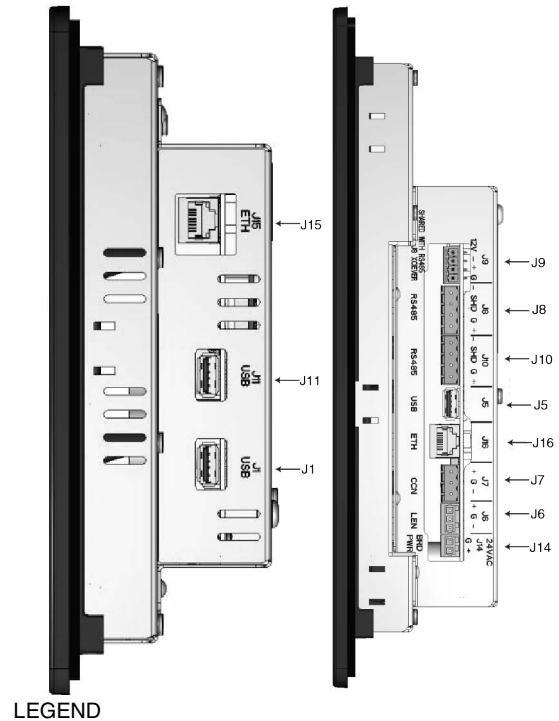

LEGEND

- J1** — USB CONNECTOR
- J5** — USB CONNECTOR
- J6** — LEN CONNECTOR
- J7** — CCN CONNECTOR
- J8** — RS485, BACnet MS/TP OR Modbus RTU
- J9** — RNET (future)
- J10** — RS485
- J11** — USB CONNECTOR
- J14** — POWER SUPPLY CONNECTOR (24 VAC)
- J15** — ETHERNET CONNECTOR, PORT 0 (DEFAULT IP: 169.254.1.1, Mask: 255.255.0.0)
- J16** — ETHERNET CONNECTOR, PORT 1 (DEFAULT IP: 192.168.100.100, mask: 255.255.255.0)

NOTES:

1. Either BACnet/MSTP or BACnet/IP can be enabled and either Modbus/RTU or Modbus/TCP/IP can be enabled. Controller does not allow both to be enabled at the same time.
2. Modbus RTU can be configured simultaneously with BACnet IP.
3. BACnet MS/TP can be configured simultaneously with Modbus TCP/IP.

Fig. 1 — PIC6 Connectors

CAUTION

Maintain the correct polarity when connecting the power supply to the boards. Otherwise, the boards may be damaged.

SIOB (Starfire Input/Output Board)

The SIOB is the purge control module, supplied from a 24VAC supply reference to earth ground.

IOB (Input/Output Board)

The IOB is supplied from a 24 VAC supply reference to earth ground.

IOB CONFIGURATION

The input/output boards can be configured for different types of input/output. If an input or output type is supported for the specific channel then it can be modified in the Configuration Menu as shown in Table 1.

Table 1 — IOB Configuration

ANALOG INPUT		ANALOG OUTPUT	
0	Disable	0	Disable
1	0 to 5 VDC	1	4 to 20 mA
2	4 to 20 mA	2	0 to 10 VDC
3	10 kΩ (thermistor)		
4	5 kΩ (thermistor)		
5	Ohm (Shift_Dis)		
6	100 Ohm RTD		

19DV IOB COMPONENTS AND WIRING

The components listed in Tables 2-5 are available at the user's terminal block on the IOB. Some are available only if the unit is operating in Remote mode. Table 6 lists SIOB inputs and outputs. Figures 2-4 show IOB wiring diagrams and Fig. 5 is the legend. Figures 6-9 show additional control wiring.

Table 2 — 19DV IOB1 Connections

DESCRIPTION	CHANNEL	TERMINAL	TYPE	OPTIONAL
Entering Chilled Water Temperature	AI1	J16-1,5	5 kΩ	—
Leaving Chilled Water Temperature	AI2	J16-2,6	5 kΩ	—
Entering Condenser Water Temperature	AI3	J16-3,7	5 kΩ	—
Leaving Condenser Water Temperature	AI4	J16-4,8	5 kΩ	—
Evaporator Refrigerant Liquid Temperature	AI5	J15-6,12	5 kΩ	—
Discharge Gas Temperature	AI6	J15-5,11	5 kΩ	—
Condenser Pressure	AI7	J15-4,10	5 VDC	—
Evaporator Pressure	AI8	J15-3,9	5 VDC	—
Economizer Pressure	AI9	J15-2,8	5 VDC	Yes
Chiller Status Output (ON=20mA, OFF=4mA, TRIPOUT=8mA, Not Off and Compressor not running=12mA)	AO1	J14-1,4	4 to 20 mA	Yes
Evaporator Flow Switch	DI1	J13-5 (5TB-9,10)	24 VAC	Yes, NO (dry contact); closed indicates Flow
Condenser Water Flow Switch	DI2	J13-6 (5TB-11,12)	24 VAC	Yes, NO (dry contact); closed indicates Flow
Remote Contact	DI3	J13-7 (5TB-13,14)	24 VAC	Yes, NO (dry contact); closed indicates start chiller signal
Remote Emergency Stop Input	DI4	J13-8 (5TB-15, 16)	24 VAC	Yes, NO (dry contact); closed indicates stop chiller signal
Economizer Bypass Valve	DO1	J12-7	24 VAC	Yes
Refrigerant Pump	DO2	J12-10	24 VAC	—
Chiller Alarm Relay	DO3	J12-2 (5TB-3,4)	24 VAC	Yes
Free Cooling Valve	DO4	J12-5	24 VAC	Yes

LEGEND
IOB — Input/Output Board
NO — Normally Open
SV — Solenoid Valve

NOTES:
 1. See Fig. 2 for IOB1 wiring diagram.
 2. For pressure readings, only Vout (output) terminal is indicated. See Fig. 2 for Vin (+) and ground (-).
 3. Defaults are shown. In some cases the IOB can be configured differently depending on job requirements.

Table 3 — 19DV IOB2 Connections

DESCRIPTION	CHANNEL	TERMINAL	TYPE	OPTIONAL
Condenser Refrigerant Vapor Temp	AI2		5 KOhm	Yes
Motor Winding Temperature 1	AI1	J16-1,5	5 kΩ	—
EC/HGBP Valve Feedback	AI3	J16-3,7	4 to 20 mA	Yes
Pump Output Pressure	AI5	J15-6,12	5 VDC	—
Bearing Outlet Pressure	AI6	J15-5,11	5 VDC	—
Bearing Inlet Pressure	AI7	J15-4,10	5 VDC	—
Auto Demand Limit Input	AI8	J15-3,9 (5TB-23,24)	4 to 20 mA	Yes
Refrigerant Leak Sensor	AI9	J15-2,8 (5TB,25,26)	4 to 20 mA	Yes
Pump Input Pressure	AI10	J15-1,7	5 VDC	—
Guide Vane 1 Output	AO1	J14-1,4	4 to 20 mA	—
EC/HGBP Modulating Output	AO3	J14-3,6	4 to 20 mA	Yes
Liquid Level Switch	DI2	J13-6	24 VAC	—
High Pressure Switch	DI3	J13-7	24 VAC	—
Ice Build Contact	DI4	J13-8,4. (5TB-17,18)	24 VAC	Yes, NO (dry contact)
Condenser Control Valve	DO1	J12-7	24 VAC	—
Evaporator Control Valve	DO2	J12-10	24 VAC	—
VFD Run/Stop Interlock	DO3	J12-2	24 VAC	Yes
Economizer Isolation Valve (Liquid Bypass Option)	DO4	J12-5	24 VAC	—

LEGEND
EC — Envelope Control
HGBP — Hot Gas Bypass
IOB — Input/Output Board
NO — Normally Open

NOTES:
 1. See Fig. 3 for IOB2 wiring diagram.
 2. For pressure readings, only Vout (output) terminal is indicated. See Fig. 3 for Vin (+) and ground (-).
 3. Defaults are shown. In some cases the IOB can be configured differently depending on job requirements.

Table 4 — 19DV IOB3 Connections

DESCRIPTION	CHANNEL	TERMINAL	TYPE	OPTIONAL
1st Stage Bearing Temperature	AI1	J16-1,5	5 kΩ	—
2nd Stage Bearing Temperature	AI2	J16-2,6	5 kΩ	—
Guide Vane 2 Actual Position	AI4	J16-4,8	4 to 20 mA	—
Remote Reset Temperature	AI5	J15-6,12 (5TB-27,28)	5 kΩ	Yes
Guide Vane 1 Actual Position	AI6	J15-5,11	4 to 20 mA	—
Common Chilled Water Supply (CHWS) Temperature	AI7	J15-4, 10 (5TB,29,30)	5 kΩ	Yes
Auto Water Temperature Reset	AI8	J15-3,9 (5TB-31,32)	4 to 20 mA	Yes
Common Chilled Water Return (CHWR) Temperature	AI9	J15-2, 8 (5TB-37,38)	5 kΩ	Yes
Head Pressure Output	AO1	J14-1,4	4 to 20 mA	Yes
Head Pressure Output2	AO2	HDPV_OU2	4 to 20 mA	Yes
Guide Vane 2 Output	AO3	J14-3, 6 (5TB-5,6)	4 to 20 mA	No
Spare Safety	DI3	J13,7 (5TB-19,20)	24 VAC	Yes, NO (dry contact)
Chiller Run Status Output (OFF=0V, ON, ON=24 VAC)	DO1	J13-7	24 VAC	Yes
Chilled Water Pump	DO3	J12-2 (5TB-5,6)	24 VAC	Yes
Condenser Water Pump	DO4	J12-5 (5TB-7,8)	24 VAC	Yes

LEGEND

IOB — Input/Output Board
NO — Normally Open

NOTES:

1. See Fig. 3 for IOB3 wiring diagram.
2. For pressure readings, only Vout (output) terminal is indicated. See Fig. 3 for Vin (+) and ground (-).
3. Defaults are shown. In some cases the IOB can be configured differently depending on job requirements.

Table 5 — 19DV IOB4 Connections

DESCRIPTION	CHANNEL	TERMINAL	TYPE	OPTIONAL
Entering Evaporator Water Pressure / Chilled Water Delta P	AI3	J16-7(5TB51, 52)	5 VDC	Yes
Leaving Evaporator Water Pressure / Condenser Water Delta P	AI4	J16-8(5TB-48, 49)	5 VDC	Yes
Entering Condenser Water Pressure	AI5	J15-6(5TB-45, 46)	5 VDC	Yes
Leaving Condenser Water Pressure	AI6	J15-5(5TB-42, 43)	5 VDC	Yes
Evaporator Water Flow Measurement	AI8	J15-3, 9(5TB-53, 54)	4 to 20 mA	Yes
Condenser Water Flow Measurement	AI9	J15-2, 8(5TB-55, 56)	4 to 20 mA	Yes
Chilled Water Pump (Variable)	AO1	J14-1, 4 (5TB-57, 58)	4 to 20 mA	—
Condenser Water Pump (Variable)	AO2	J14-2, 5 (5TB-59, 60)	4 to 20 mA	—
Tower Fan (Variable)	AO3	J14-3, 6 (5TB-61, 62)	4 to 20 mA	—
Customer Alert	DI3	J13-3, 7 (5TB-63,64)	24 VAC	Yes, NO (dry contact)
Free Cooling Start Switch	DI4	J13-4, 8 (5TB-65,66)	24 VAC	Yes, NO (dry contact)
Free Cooling Mode	DO1	J12-7 (5TB-67)	24 VAC	—
Power Request Output	DO2	J12-10 (5TB-68)	24 VAC	—
Tower Fan High	DO3	J12-2 (5TB-69)	24 VAC	Yes
Tower Fan Low	DO4	J12-5 (5TB-70)	24 VAC	Yes

LEGEND

IOB — Input/Output Board
NO — Normally Open

NOTES:

1. See Fig. 4 for IOB4 wiring diagram.
2. For pressure readings, only Vout (output) terminal is indicated. See Fig. 4 for Vin (+) and ground (-).
3. Defaults are shown. In some cases the IOB can be configured differently depending on job requirements.

Table 6 — SIOB Input/Output Descriptions

DESCRIPTION	CHANNEL	TERMINAL	TYPE	OPTIONAL
Purge Compressor Suction Temperature	AI1	J25-1,2	5 kΩ	—
Purge Level Switch Low Relay	DI1	J1-1, 2	24 VAC	—
Purge Level Switch High Relay	DI2	J1-3, 4	24 VAC	—
Purge Condenser Valve	DO1	J2-2	24 VAC	—
Purge Compressor Valve	DO2	J2-1	24 VAC	—
Purge Pumpout Valve	DO3	J6-2	24 VAC	—
Purge Drainage Valve	DO4	J6-1	24 VAC	—
Purge Regeneration Valve	DO5	J23-2	24 VAC	—
Purge Discharge Valve	DO6	J22-2	24 VAC	—
Purge Vacuum Pump Relay	DO7	J7-7, 8	24 VAC	—
Purge Compressor Contactor	DO8	J7-5, 6	24 VAC	—
Purge Idle Drain Control Valve	DO9	J7-2,4	24 VAC	—
Purge Heater Contactor	DO10	J7-1, 2	24 VAC	—

LEGEND FOR FIG. 2-6

- COMPONENT TERMINAL
- CONDUCTOR MALE FEMALE CONNECTOR
- FIELD WIRING
- OPTIONAL WIRING
- COMPONENT/PANEL ENCLOSURE
- TERMINAL BLOCK FOR FIELD WIRING
- TERMINAL BLOCK FOR INTERNAL CONNECTION
- WIRE SPLICE

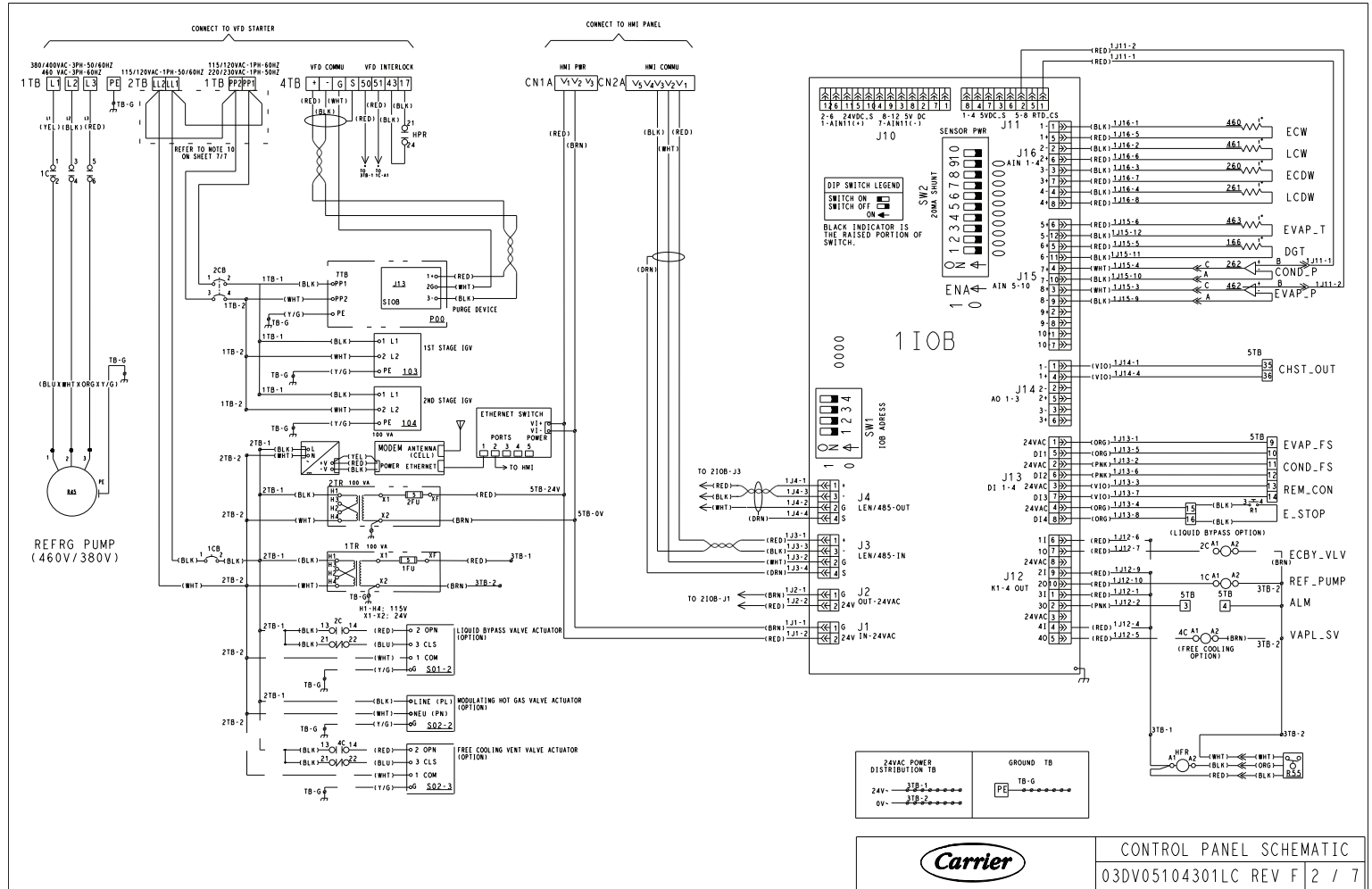

5

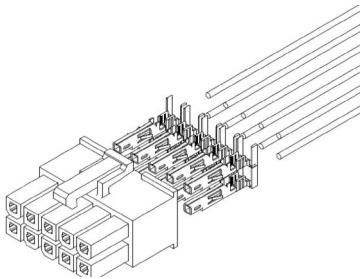
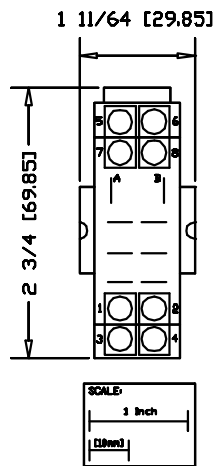

MOLEX CONNECTOR ASSEMBLY PART NO. (SHORT WIRE INCLUDED)	NO. OF PINS
19XF04003501	2
19XF04003502	4
19XF04003503	6
19XF04003504	8
19XF04003505	10
19XF04003506	12

Molex Connector Assembly

19XV05005503 BASE DIMENSIONS (REFERENCE) DIMENSIONS IN INCHES [MM]

Fig. 2 — IOB 1

NOTE: A suitable 24 VAC relay is Carrier part number 19XV05005503. Carrier recommends using a relay with a contact rating of 10 amp sealed RMS or greater.

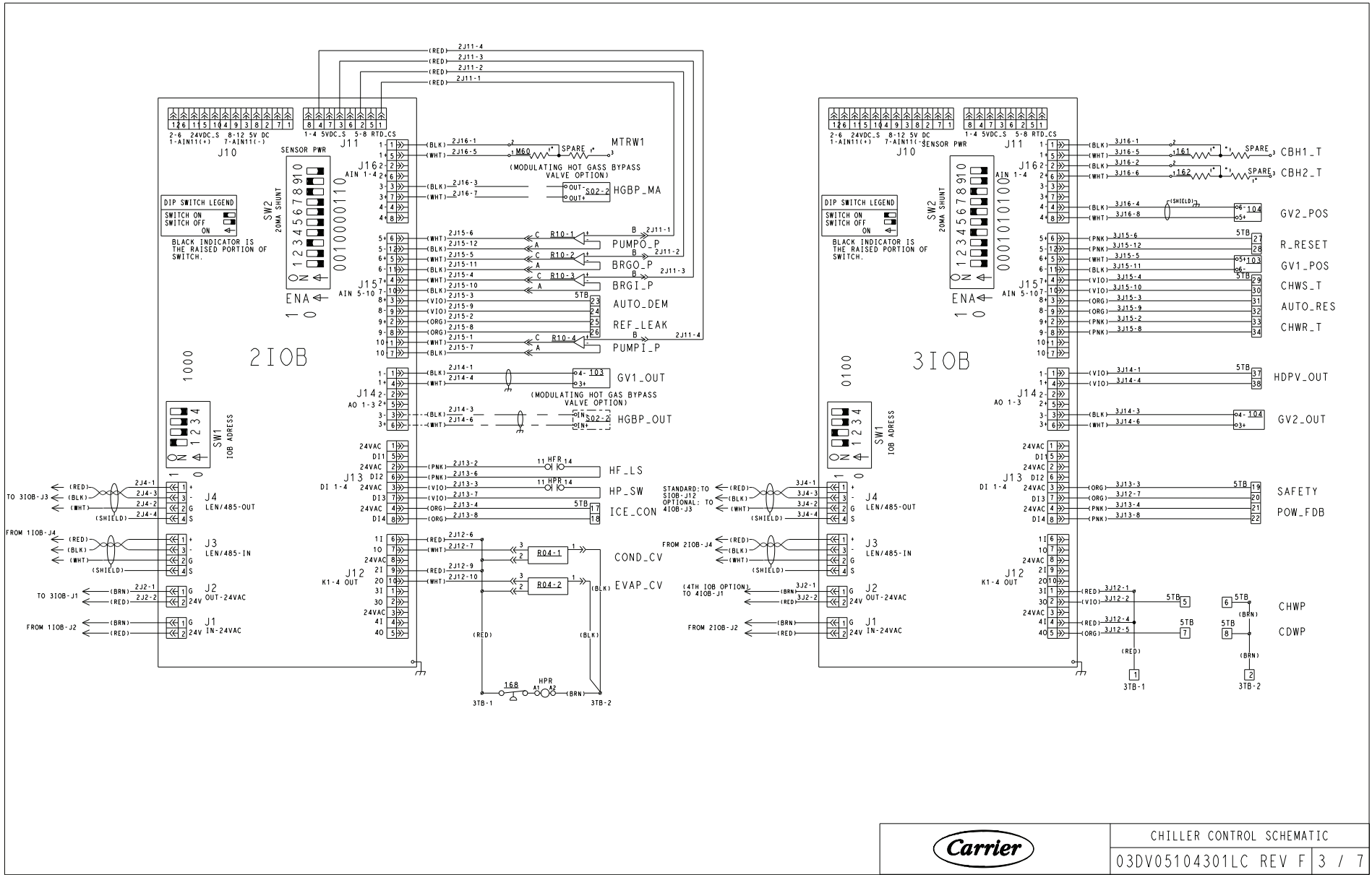
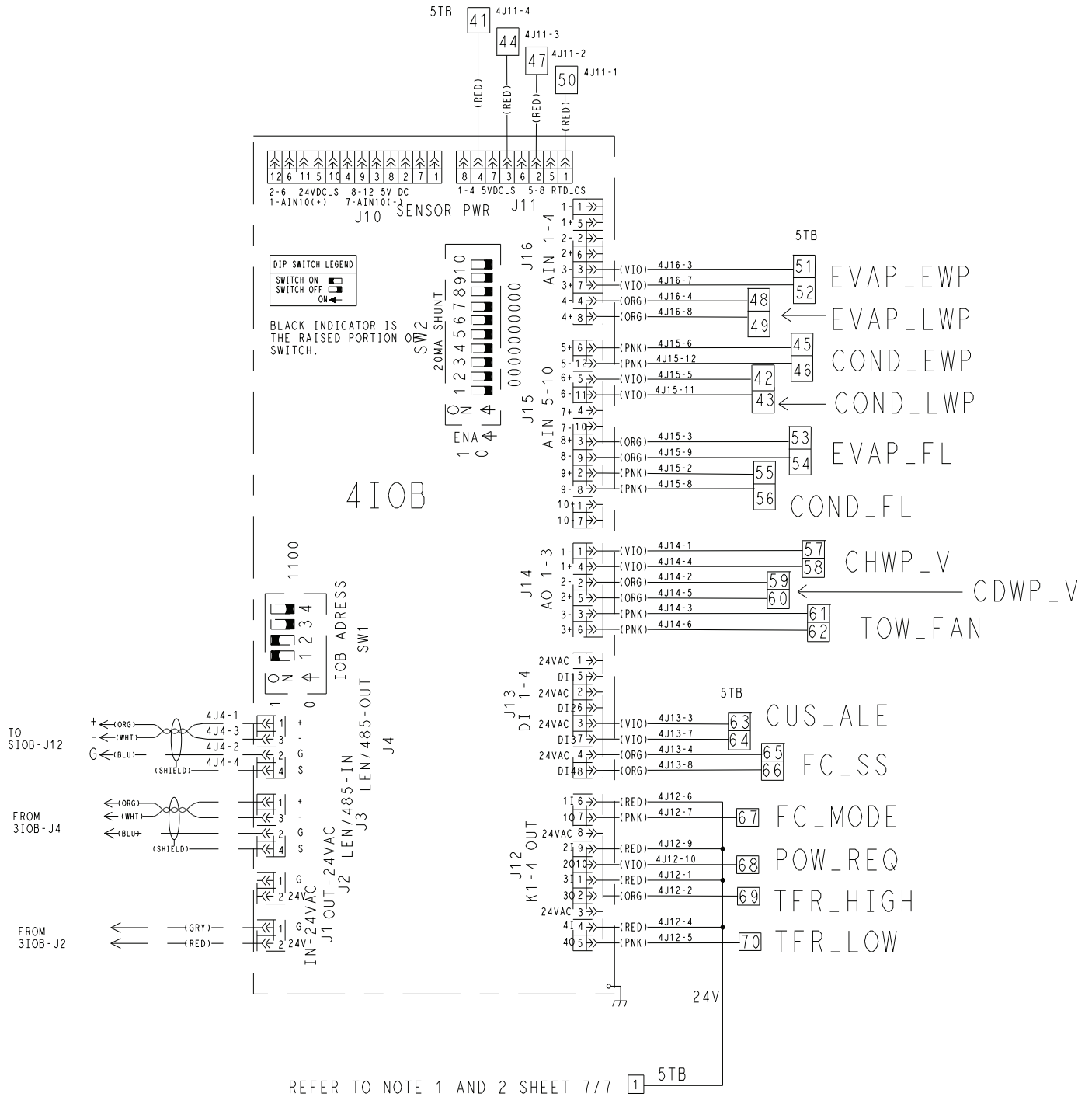

Fig. 3 — IOB2 and IOB3



THIS TYPICAL DRAWING SHOWS THE CARRIER STANDARD PRESSURE TRANSDUCER WHICH IS 5VDC POWER SUPPLY.

	CONTROL PANEL SCHEMATIC	
	03DV05104301LC REV F	4 / 7

Fig. 4 — IOB 4

LEGEND		ECBY_VLV	ECONOMIZER BYPASS VALVE		
○	DENOTES INTERNAL COMPONENT TERMINAL	ECOW	ENTERING CONDENSER WATER TEMPERATURE	461	LEAVING CHILLED WATER TEMPERATURE THERMISTOR
→	DENOTES CONDUCTOR MALE/FEMALE CONNECTOR			462	EVAPORATOR PRESSURE TRANSDUCER
—	FIELD WIRING	ECW	ENTERING CHILLED WATER TEMPERATURE	463	EVAPORATOR REFRIGERANT LIQUID TEMPERATURE THERMISTOR
—	OPTIONAL WIRING	EVAP_CV	EVAPORATOR CONTROL VALVE	M60	MOTOR WINDING TEMPERATURE 1(THERMISTOR/PT100)
—	COMPONENT/PANEL ENCLOSURE			P00	PURGE DEVICE
—	SHIELD WIRE	EVAP_EWP	ENTERING EVAPORATOR WATER PRESSURE	R04-1	CONDENSER CONTROL VALVE
—	TWISTED WIRE	EVAP_FL	EVAPORATOR WATER FLOW MEASUREMENT	R04-2	EVAPORATOR CONTROL VALVE
—	TERMINAL BLOCK FOR FIELD WIRING	EVAP_FS	EVAPORATOR WATER FLOW SWITCH	R10-1	REFRIGERANT PUMP OUTLET PRESSURE TRANSDUCER
—	WIRE SPLICE	EVAP_LWP	LEAVING EVAP WATER PRESSURE	R10-2	BEARING OUTLET PRESSURE TRANSDUCER
○	INTERNAL TERMINAL BLOCK/TERMINAL	EVAP_P	EVAPORATOR PRESSURE	R10-3	BEARING INLET PRESSURE TRANSDUCER
		EVAP_T	EVAPORATOR REFRIGERANT TEMPERATURE	R10-4	REFRIGERANT PUMP INLET PRESSURE TRANSDUCER
		FC_MODE	FREE COOLING MODE		
BLK	BLACK	FC_SS	FREE COOLING START SWITCH	R45	REFRIGERANT PUMP
BLU	BLUE	FIRE_LOCK	FIRE ALARM INTERLOCK	R55	HIGH FLOAT LIQUID LEVEL SWITCH
BRN	BROWN	GV1/2_POS	IGV1/2 ACTUAL POS	S01-2	HIGH FLOAT LIQUID LEVEL SWITCH
GRN	GREEN	GV1/2_OUT	IGV1/2 OUTPUT		
GRY	GREY	HDPV_OUT	HEAD PRESSURE OUTPUT	S02-2	MODULATING HOT GAS CONTROL VALVE ACTUATOR
RED	RED	HGBP_MA	MODULATING HOT GAS VALVE FEEDBACK	S02-3	FREE COOLING VENT VALVE ACTUATOR
ORG	ORANGE	HGBP_OUT	MODULATING HOT GAS VALVE OUTPUT MA		
WHT	WHITE	HF_LS	HIGH FLOAT LIQUID LEVEL SWITCH		
YEL	YELLOW	HP_SW	HIGH PRESSURE SWITCH	1C	REFRIGERANT PUMP CONTACTOR
G/Y	GREEN/YELLOW	ICE_CON	ICE BUILD CONTACT	2C	LIQUID BYPASS VALVE RELAY
	CONTROL ABBREVIATION LIST	LCOW	LEAVING CONDENSER WATER TEMPERATURE	4C	FREE COOLING VENT VALVE RELAY
ALM	CHILLER ALARM	LCW	LEAVING CHILLED WATER TEMPERATURE	1-2CB	MICRO CIRCUIT BREAKER
AUTO_DEM	DEMAND LIMIT INPUT	MTRW1	MOTOR WINDING TEMPERATURE 1	1FU	FUSE_5A, TIME-DELAY, 13/32" X 1-1/2"
AUTO_RES	AUTO WATER TEMP RESET	PUMP_I_P	PUMP INLET PRESSURE	2FU	FUSE_5A, TIME-DELAY, 13/32" X 1-1/2"
BRGI_P	BEARING INLET PRESSURE	PUMPO_P	PUMP OUTLET PRESSURE	1-4 IOB	1-4 INPUT OUTPUT BOARD 1-4
BRGI_T	BEARING REF SUPPLY TEMP	REF_LEAK	REFRIGERANT LEAK DETECTOR	1TB	TERMINAL BLOCK FOR POWER CONNECTION
BRGO_P	BEARING OUTLET PRESSURE	REF_PUMP	REFRIGERANT PUMP	2TB	INTERNAL 115/120 V TERMINAL BLOCK
CBH1_T	1ST STAGE BEARING TEMP	REM_CON	REMOTE CONTACT INPUT	3TB	INTERNAL 24V TERMINAL BLOCK
CBH2_T	2ND STAGE BEARING TEMP	TFR_HIGH	TOWER FAN HIGH	4TB	TERMINAL BLOCK FOR VFD CONNECTION
CDWP	CONDENSER WATER PUMP	TFR_LOW	TOWER FAN LOW	5TB	TERMINAL BLOCK FOR CUSTOMER OPTIONAL CONNECTION
CDWP_V	CONDENSER WATER PUMP(VARIABLE SPEED OUTPUT)	TOW_FAN	TOWER FAN(VARIABLE)	7TB	230V/115V TERMINAL BLOCK (PURGE PANEL)
CHWP	CHILLED WATER PUMP	VAPL_SV	VAPOR VENTING LINE SV	1TR	TRANSFORMER 1 230V-115V/24V 100VA
CHWP_V	CHILLED WATER PUMP(VARIABLE SPEED OUTPUT)			2TR	TRANSFORMER 2 230V-115V/24V 100VA
CHST_OUT	CHILLER RUNNING(ON/OFF/READY)	103	1ST STAGE IGV	CN1A/B	CONNECTOR FOR HMI POWER
COND_CV	CONDENSER CONTROL VALVE	104	2ND STAGE IGV	CN2A/B	CONNECTOR FOR HMI COMMUNICATION
COND_DCV	CONDENSER DRAIN VALVE	161	1ST BEARING TEMP THERMISTOR	E-STOP	EMERGENCY STOP
COND_EWP	ENTERING CONDENSER WATER PRESSURE	162	2ND BEARING TEMP THERMISTOR	ETH SW	ETHERNET SWITCH
COND_FL	CONDENSER WATER FLOW MEASUREMENT	166	2ND STAGE COMPRESSOR DISCHARGE TEMPERATURE THERMISTOR	HFR	HIGH FLOAT LEVEL SWITCH
COND_FS	CONDENSER WATERFLOW SWITCH	168	HIGH PRESSURE SWITCH	HPR	HIGH PRESSURE SWITCH RELAY
COND_LWP	LEAVING COND WATER PRESSURE	260	ENTERING CONDENSER WATER TEMPERATURE THERMISTOR	HMI	HMI TOUCH SCREEN AND MAIN BOARD SAIA
COND_P	CONDENSER PRESSURE	261	LEAVING CONDENSER WATER TEMPERATURE THERMISTOR	MDM	REMOTE CONNECTIVITY MODEM
CUS_ALE	CUSTOMER ALERT	262	CONDENSER PRESSURE TRANSDUCER	PS	AC/DC POWER SUPPLY
DGT	COMPRESSOR DISCHARGE TEMPERATURE	460	ENTERING CHILLED WATER TEMPERATURE THERMISTOR	SI0B	STANDARD INPUT OUTPUT BOARD (PURGE PANEL)
				TB-G	COPPER TERMINAL BLOCK FOR GROUND

Fig. 5 — 19DV Control Panel Abbreviations

NOTE: Jumper wires installed only on 60 Hz units.
When jumper wires are installed, the power wiring from the VFD to PP1 and PP2 is not installed.

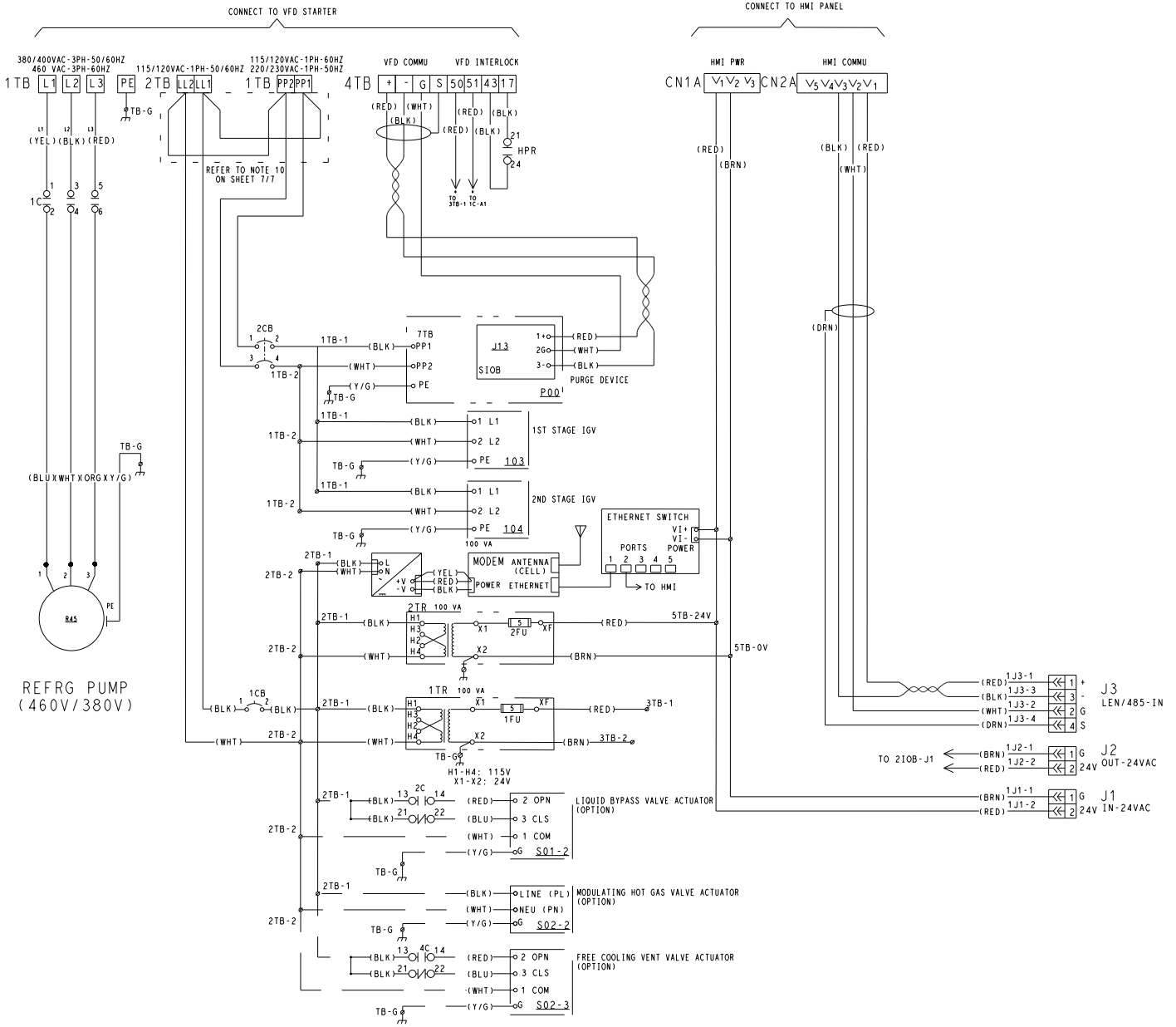

FROM 03DV05104301LC REV F

Fig. 6 — 19DV Control Wiring

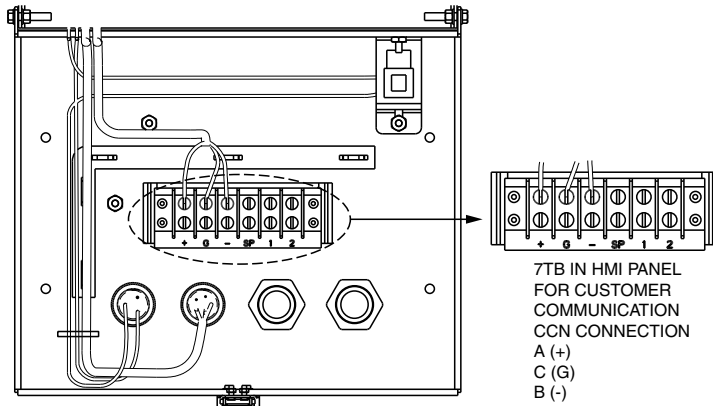

Fig. 7 — HMI Panel

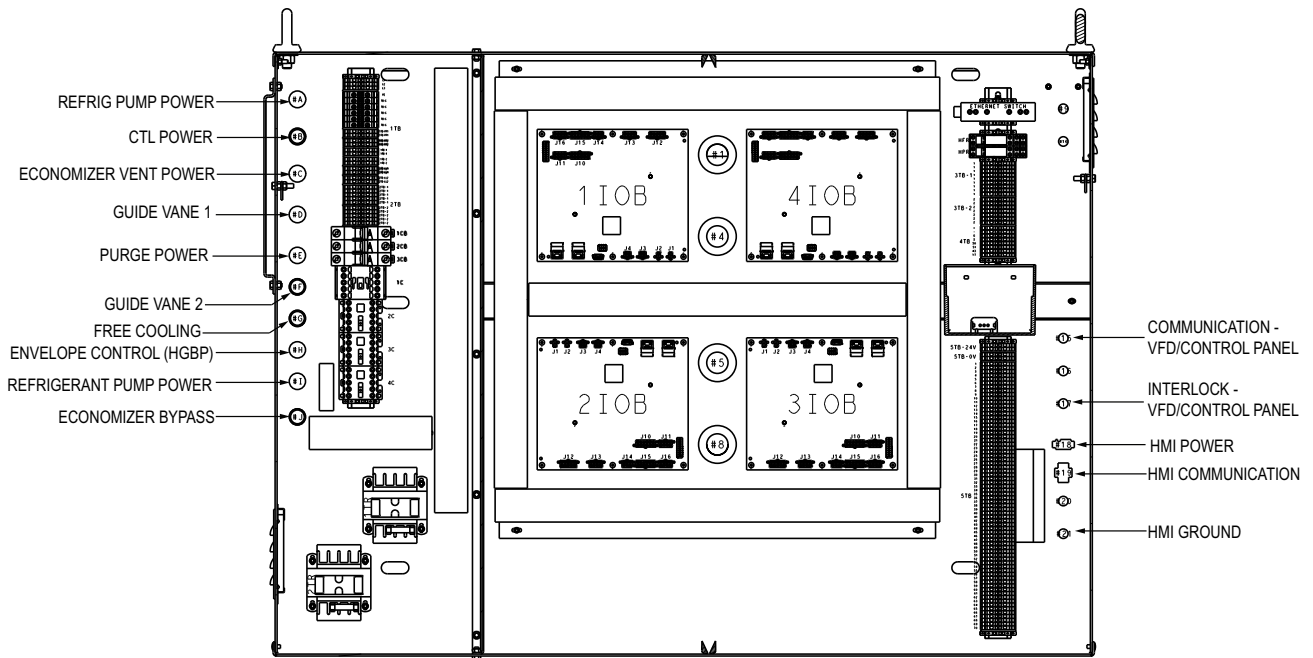

Fig. 8 — 19DV Control Panel

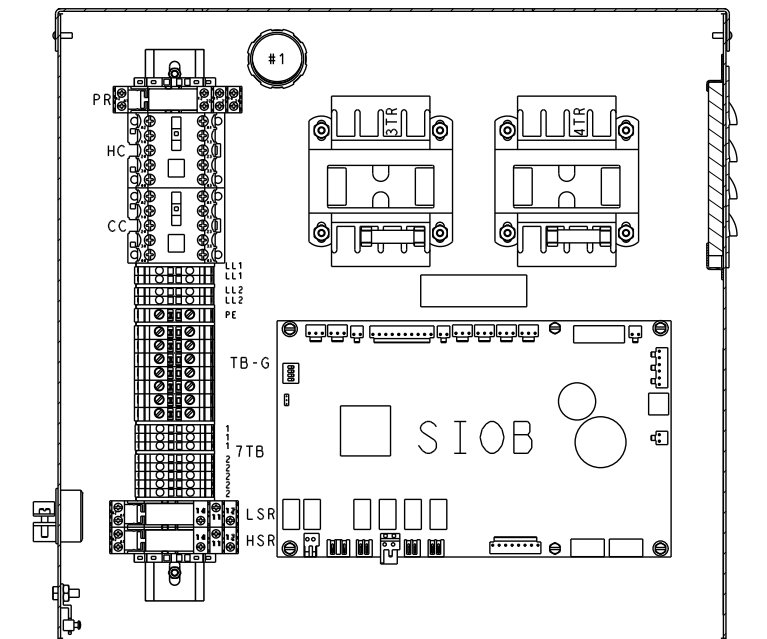

Fig. 9 — 19DV Purge Panel

Communication Cables

The communication transmission cables have the following electrical characteristics:

- 2 signal conductors and one ground conductor of 20 AWG or larger, 100% shielded
- One tinned copper braid (65% coverage)

Recommended cables are shown below:

USAGE	CABLE
Intra-Building	Belden 8772
High Temperature	Belden 85240
Plenum	Belden 89418

To avoid potential interference, route communication cables between the starter and the chiller control panels as far away as possible from high voltage cable and other likely disturbances. Always separate communication cables from other cables and always run wiring as directly as possible.

Sensors

PRESSURE TRANSDUCERS

Pressure transducers measure and control the pressures in the unit. These electronic sensors deliver 0 to 5 VDC. The transducers can be calibrated through the controller. The pressure transducers are connected to the IOBs. See Table 7.

TEMPERATURE SENSORS

The system uses electronic sensors to measure and control the temperatures in the unit. There are three types of temperature sensors: 5K thermistor, 10K thermistor, and RTD (resistance temperature detector, 100 ohm, 3-wire) based on IOB channel configurations. The temperature sensor range is -40°F (-40°C) to 245°F (118°C). See Table 8.

Controls Outputs

EVAPORATOR/CONDENSER WATER PUMP

The controller regulates the evaporator/condenser water pump. Note that Carrier requires full or parallel pump control.

INLET GUIDE VANE

The inlet guide vane adjusts the refrigerant vapor flow into the compressor to adapt to change in the operating conditions of the machine. To adjust the refrigerant flow, the guide vane opens or closes to vary the cross-section of the refrigerant path. The high degree of accuracy with which the guide vane is positioned ensures that the flow of refrigerant is precisely controlled.

ECONOMIZER ISOLATION VALVE (OPTION)

The economizer is an on/off valve that shuts off the economizer gas vent line leading to the second stage of the compressor.

ECONOMIZER LIQUID BYPASS VALVE (OPTION)

The economizer liquid bypass valve is opened if lift difference between condenser and evaporator is small. When the valve is open liquid refrigerant can bypass the economizer and flow directly from the condenser to the evaporator and thereby avoid the pressure loss associated with the economizer.

ENVELOPE/HGBP CONTROL VALVE

The modulating Envelope Control valve artificially loads the chiller and keeps it running under low load conditions or helps to prevent surge conditions. Since this function can also reduce the operating efficiency of the machine, this is a user-selectable and configurable option.

VFD

The VFD modifies motor frequency to allow compressor start-up and capacity control. The VFD controls continually monitor parameters to ensure compressor protection. If a problem occurs, the controller triggers an alarm and the compressor is stopped.

FREE COOLING VALVE (OPTION)

The free cooling control allows the chiller to provide cooling without running the compressor. The free cooling vent valve is opened, allowing the refrigerant to bypass the compressor and go straight from the evaporator to the condenser. This control mode can only be used when the chiller is OFF and the external air temperature is low enough to support this operation.

TOWER FAN HIGH/LOW

The controls provide optional fan tower control by a 24 VAC output for tower fan low and another for tower fan high speed.

Table 7 — Pressure Transducers

PRESSURE TRANSDUCER	PURPOSE
Pump Input Pressure	Measures the pressure at the input of the refrigerant pump
Pump Output Pressure	Measures the pressure at the output of the refrigerant pump
Bearing Inlet Pressure	Measures the pressure at the bearing inlet
Bearing Outlet Pressure	Measures the pressure at the bearing outlet
Evaporator	Measures evaporator pressure
Condenser	Measures condenser pressure
Economizer	Measures economizer pressure
Evaporator Water Pressure Difference	(Optional) Measures pressure difference between entering and leaving water.
Condenser Water Pressure Difference	(Optional) Measures pressure difference between entering and leaving water.
Evaporator Entering Water	(Optional) Measures pressure of evaporator entering water
Evaporator Leaving Water	(Optional) Measures pressure of evaporator leaving water
Condenser Entering Water	(Optional) Measures pressure of condenser entering water
Condenser Leaving Water	(Optional) Measures pressure of condenser leaving water

Table 8 — Temperature Sensors

TEMPERATURE SENSOR	PURPOSE
Entering Chilled Water	Measures entering evaporator water temperature
Leaving Chilled Water	Measures leaving evaporator water temperature
Entering Condenser Water	Measures entering condenser water temperature
Leaving Condenser Water	Measures leaving condenser water temperature
Evaporator Refrigerant Liquid	Measures evaporator refrigerant liquid temperature
Compressor Discharge	Measures compressor discharge temperature
1st Stage Bearing	Measures the temperature of the bearings in the first stage of the compressor
2nd Stage Bearing	Measures the temperature of the bearings in the second stage of the compressor
Bearing Refrigerant Supply (available for older software only)	Measures the temperature of the refrigerant supply for the bearings
Chilled Water Supply (Optional)*	Measures the temperature of the chilled water supply
Chilled Water Return (Optional)*	Measures the temperature of the chilled water return
Motor Winding	Measures the temperature of each phase of the compressor motor

* Separate inputs used when the chiller is in network mode.

NOTE: Text in parentheses indicates applicable product.

USER INTERFACE

The PIC6 Human Machine Interface (HMI) is a color 10.4-in. TFT touch screen. Navigation is either direct from the touch screen interface or by connecting to a web interface at the Ethernet IP port of the controller. The navigation menus are the same for both connection methods.

Web Connection

Two web connections may be authorized at the same time. When two users are connected simultaneously, there is no priority between users; that is, the last modification is in effect regardless

of the user. Connection is from a personal computer using a Java-enabled web browser. See “CONTROLLER SETTINGS” on page 42 for configuration instructions.

The minimum browser configuration includes:

- Microsoft Internet Explorer (version 8 or higher) or Mozilla Firefox (version 3.5.2 or higher). In the advanced connection options, add the unit address to the address list. Do not use a proxy server.
- Java platform (version 6 or higher). In the control panel, deselect (uncheck) the option that allows storing temporary internet files and use a direct connection.

To access the PIC6 user interface, enter the IP address of the unit in the address bar of the web browser. The IP address can be viewed or changed from the PIC6 interface. For more information on the web browser and Java platform configuration, see the Diagnostics and Troubleshooting section.

General Interface Features

ICONS

Table 9 shows general interface icons.

Table 9 — Interface Icons

ICON	MEANING
	Green: Indicates unit is running Gray: Indicates unit is off
	Home
	Main menu
	Indicates user is logged off
	Indicates user is logged in
	Gray: Indicates no alarm or alert is active Red: Indicates alarm or alert
	Back (not visible in main menu)
	Previous and next screen

SCREENS

The Human Machine Interface includes the following screens:

- Home screen, which displays the main parameters
- Menu screens for navigation
- Data/configuration screens, which list the parameters by type
- Operating mode selection screen
- Password entry and language selection screen
- Parameter modification screen
- Time schedule screen

If the interface is not used for a long period, it goes into screen-saver mode and displays a black screen. However, the control is always active and the unit operating mode remains unchanged. When the user presses the black screen, the Home screen is displayed.

System Overview (Home) Screen

Figure 10 shows the system overview screen. Press a component image to see current status. For details, see Status Display Screens on page 15.

Messages

The Set Point screen, On/Off screen, User Login screen, and Main Menu screens described in the next sections may display status messages at the bottom of the screen. See Table 10.

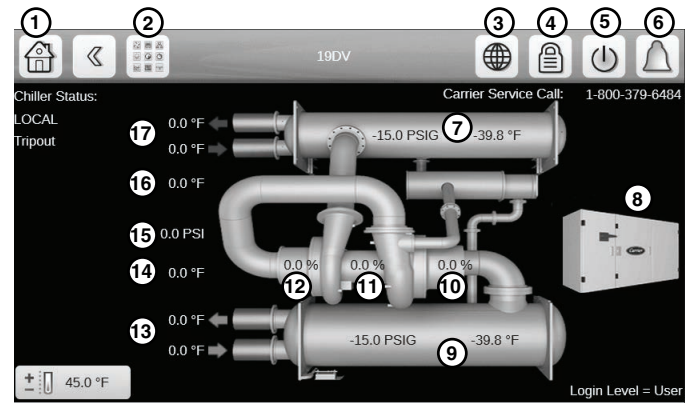

LEGEND

- 1 — Home Screen Access Button
- 2 — Main Menu Access Button
- 3 — Globe Button
- 4 — User Login Screen Access Button
- 5 — Unit Start/Stop Access Button
- 6 — Alarm Menu Access Button
- 7 — Condenser Saturated Pressure and Temperature
- 8 — VFD Status
- 9 — Evaporator Saturated Pressure and Temperature
- 10 — Guide Vane 1 Position Percentage
- 11 — Motor Load Current Percentage
- 12 — Guide Vane 2 Position Percentage
- 13 — Evaporator Water Inlet and Outlet Temperature
- 14 — Second Stage Bearing Temp
- 15 — Refrigerant Pressure Differential
- 16 — First Stage Bearing Temp
- 17 — Condenser Water Inlet and Outlet Temperature

Fig. 10 — System Overview (Home) Screen

Table 10 — Status Messages

MESSAGE	STATUS
COMMUNICATION FAILURE!	Equipment controller did not respond while reading the table content.
ACCESS DENIED!	Equipment controller does not allow access to one of the table data blocks.
LIMIT EXCEEDED!	The value entered exceeds the table limits.
Save changes?	Modifications have been made. The interface waits to confirm exit; press Save or Cancel.
HIGHER FORCE IN EFFECT!	Equipment controller rejected a Force or Auto command because the interface force level is lower than that of the equipment controller.

Set Point Screen

The Set Point screen displays the current set point table. See Fig. 11. For more information about these settings, see the Set Point section on page 18.

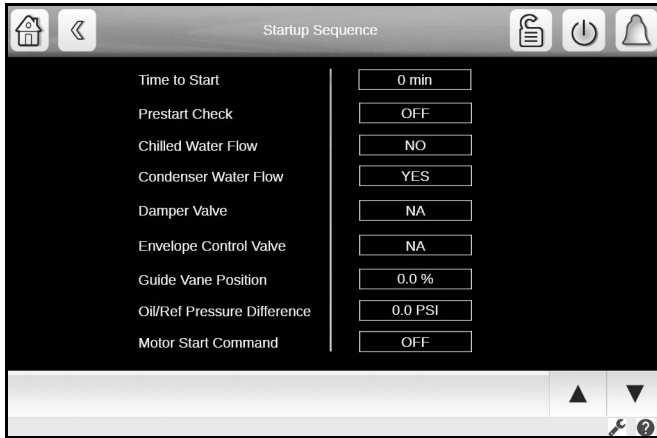



Fig. 11 — Set Point Screen

Unit Start/Stop Screen

The Unit Start/Stop screen allows the user to select the unit operating mode.

For unit start-up, with the unit in Local Off mode, press the gray Off icon  to display the list of operating modes. Select the required mode to start up the chiller. See Fig. 12.

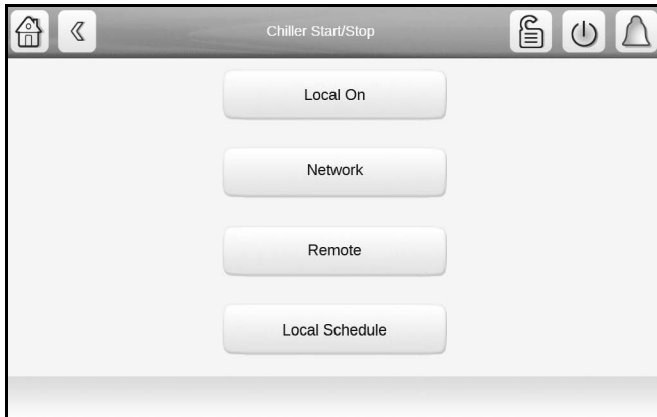

Fig. 12 — Unit Start/Stop Screen

When a start-up mode is selected, a status screen displays the progress of the start-up sequence (Fig. 13).

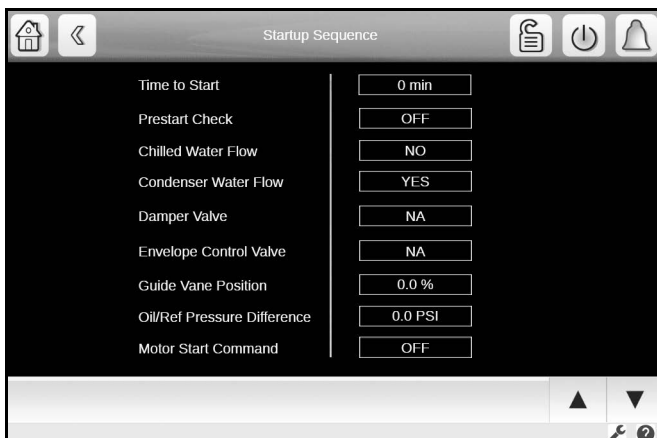

Fig. 13 — Start-Up Sequence Progress

To stop the unit, press the green On icon . Then press Confirm Stop to stop the unit, or press the Back icon to cancel the stop and return to the previous screen. See Fig. 14.



Fig. 14 — Confirm Stop

User Login Screen

Use this screen to login or log off and to set interface language and measurement system. There are three levels of password access:

- Basic access allows the user to view all data without a password.
- User access gives the user the additional ability to view and change many configuration settings, including set points and schedules. The default User password is 1111.
- Service access can be granted through Carrier Smart Service by an administrator. Password is good for 7 days and gives access to all Service tables.
- Factory access (located under Service Login icon) allows access to critical factory configuration settings and only authorized users will have access to these menus using Carrier Smart Service.

From the Home screen, touching the Globe  icon displays the Language and Units Selection screen. See Fig. 15.



NOTE: The active language is bracketed by arrows.

Fig. 15 — User Login Screen — Language and Units Selection

The Lock icon  on the Home screen allows access to the password menu and displays current software version. See Fig. 16.



Fig. 16 — User Login Screen — Password Menu

Main Menu Screen

To access the Main Menu screen, press the Main Menu icon . Press the icons on the screen to access the appropriate table or menu. Press the arrows at the bottom right corner, if present, to navigate through pages of tables. The options shown on the Main Menu screen depend on the user's level of access (see the section User Login Screen on page 13). Figures 17 and 18 shows the Main Menu screen as it appears for the User level of access.

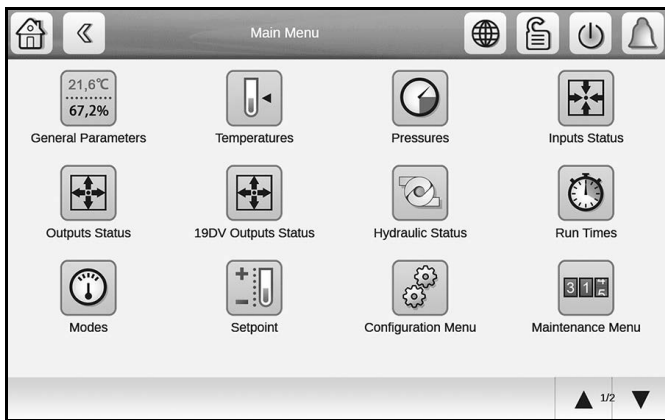

Fig. 17 — Main Menu Screen, Page 1 (User Access)

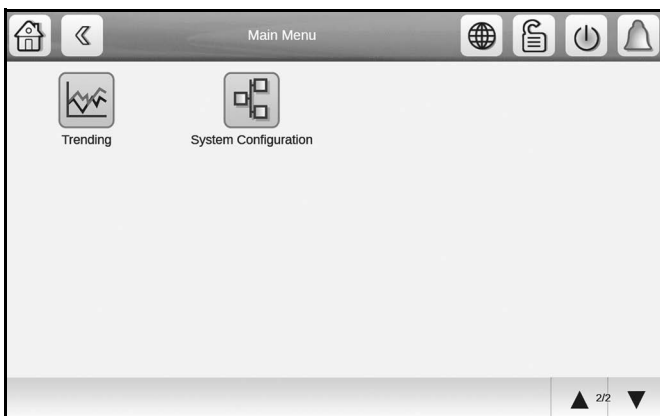

Fig. 18 — Main Menu Screen, Page 2 (User Access)

Configuration Screen

To access the Configuration menu, press the Configuration icon on page 2 of the Main Menu (User, Service, or Factory access level). The Configuration menu opens. Then press the General Configuration icon on the Configuration menu. Press the arrows at the bottom right corner to navigate through pages.

See Fig. 19. (Certain configuration settings are available only for Service or Factory access levels.) Refer to Appendix A, page 54, for more information about Configuration options.

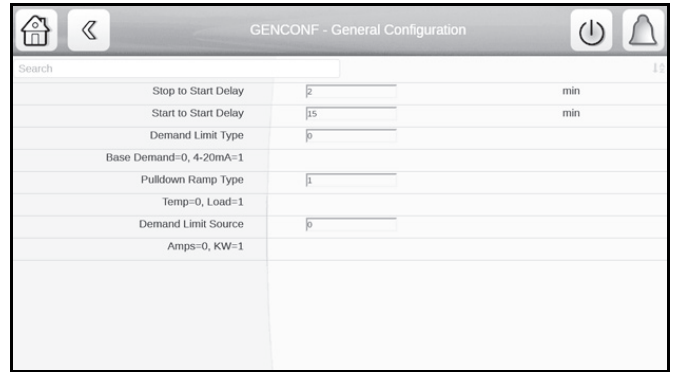

Fig. 19 — General Configuration Screen

After changing a value, press Return. The Save and Cancel icons are displayed. Press the Save icon to save the changed value. Figure 20 shows an example.

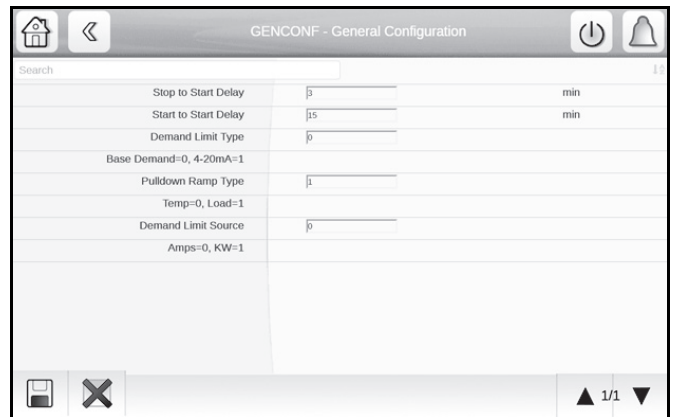

Fig. 20 — Saving a Change (General Configuration)

Schedule Menu Screen

To access the Schedule menu screen, press on the Configuration menu screen. Select Local Schedule, Ice Build Schedule, or Network Schedule as applicable. Press the arrows at the bottom right corner to navigate through the time periods. See Fig. 21.

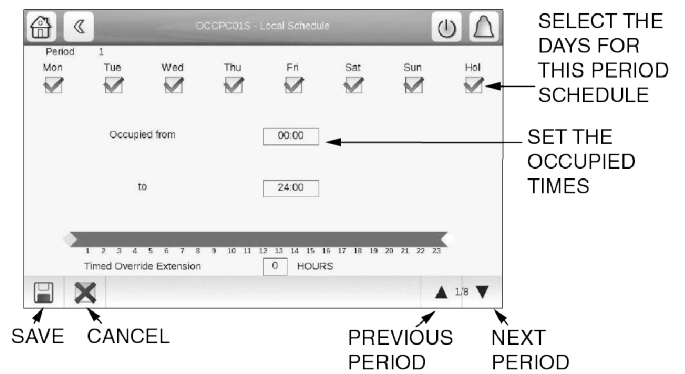

Fig. 21 — Local Schedule Menu Screen

Status Display Screens

Figure 22 shows the system status overview (home) screen. Press any component on the screen to see the status of that component. Press the arrows at the bottom right corner to navigate through the component status displays. Figures 23-29 show the component status displays.

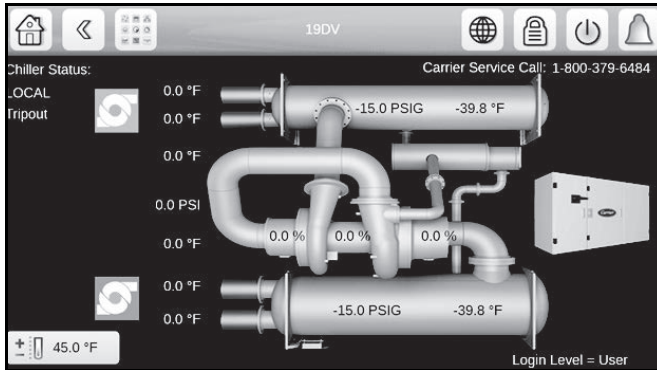

Fig. 22 — System Overview (Home) Screen

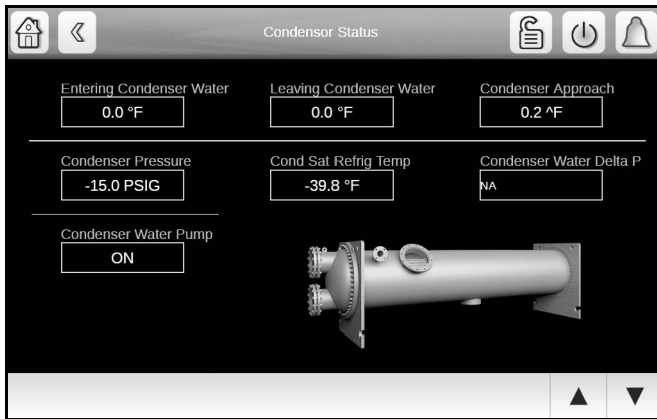

Fig. 23 — Condenser Status

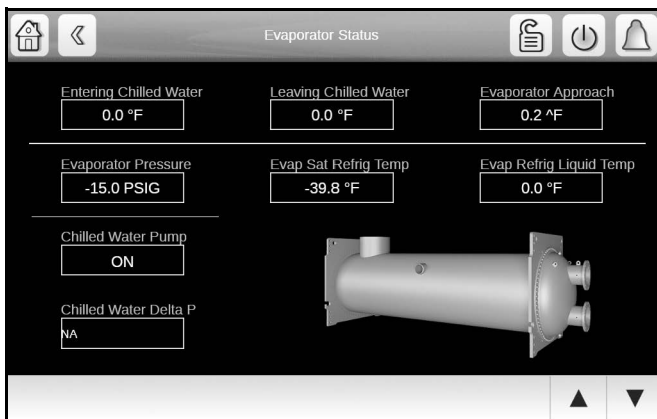

Fig. 24 — Evaporator Status

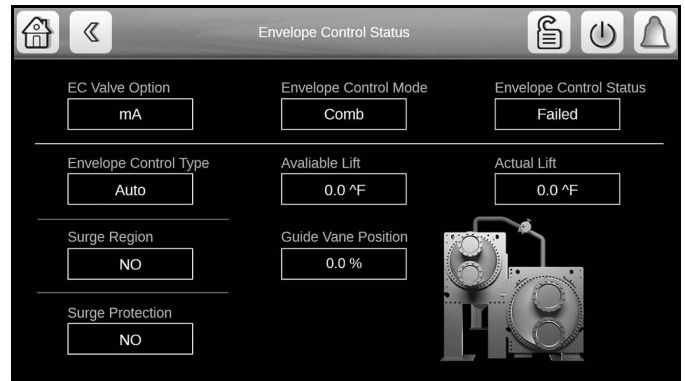

Fig. 25 — Envelope Control Status

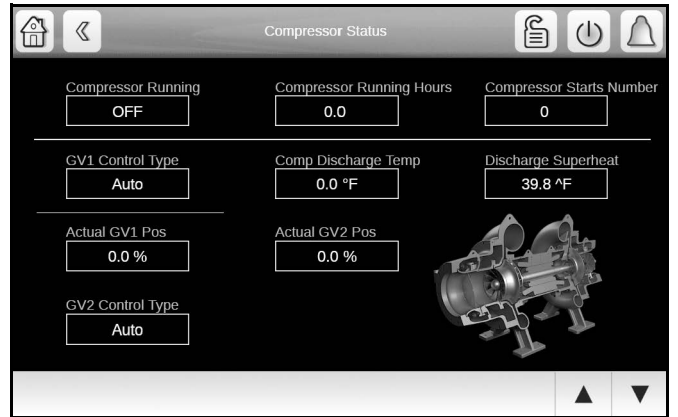

Fig. 26 — Compressor Status

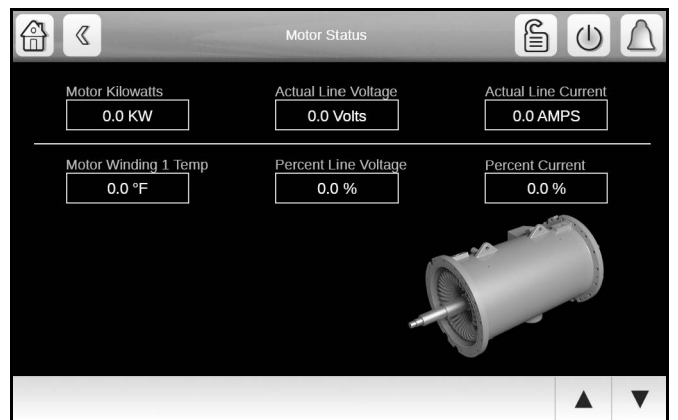

Fig. 27 — Motor Status

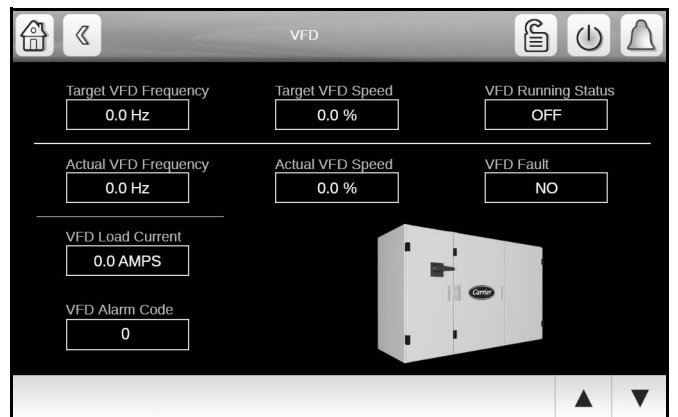

Fig. 28 — VFD Status

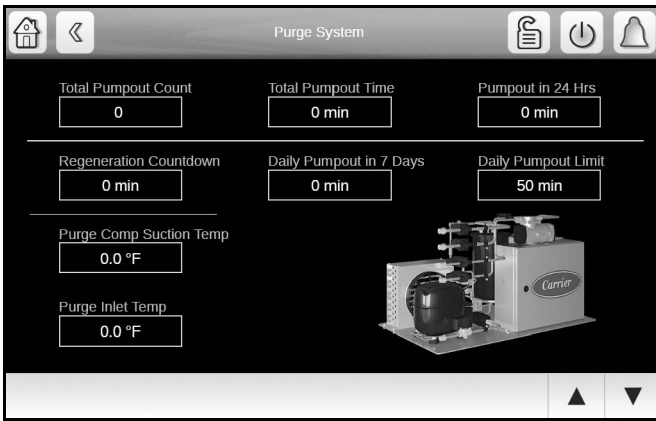

Fig. 29 — Purge Status

CONTROL OPERATION

Start-Stop Control

This function controls the chiller START-STOP command. The four selectable control modes are as follows: LOCAL, LOCAL SCHEDULE, REMOTE, or NETWORK. See Unit Start/Stop Screen on page 13. Specific control sources are valid to start or stop the chiller for each control mode.

LOCAL

When the control mode is LOCAL, the chiller can be started by the “Local ON” button on the PIC6 interface screen, and can be shut down by the Confirm Stop button on the screen or by the EMSTOP software point.

LOCAL SCHEDULE

When the control mode is LOCAL SCHEDULE, the chiller will be started automatically if the configurable local schedule is Occupied. The chiller can be shut down by the unoccupied schedule, the Stop button on the PIC6 interface screen, or by the EMSTOP software point.

REMOTE

When the control mode is REMOTE, the chiller will be started by the remote discrete input (REM_CON) located on the I/O board. The chiller can be shut down by the remote discrete input, the Stop button on the PIC6 interface screen, or by the EMSTOP software point.

NETWORK

When the control mode is NETWORK, the chiller can be started and stopped by the CHIL_S_S and CHIL_OCC software points, which are written by other equipment through network commands and network schedule (both must be TRUE for chiller to start). To shut down the chiller, use the EMSTOP software point or stop using the HMI.

NOTE: There is a STOP OVERRIDE point in the GENUNIT table. If this point is enabled the chiller cannot be started.

Compressor Run Status

Compressor run status is shown at the top of the system overview (home) screen. Table 11 lists chiller status numbers, names, and descriptions.

Chiller Start-Up Sequence

PRE-START CHECK

Once start-up begins, the controller performs a series of pre-start tests to verify that all pre-start alerts and safeties are within limits.

Progress is shown on the Startup Sequence screen (see Fig. 30). This screen can be accessed by touching the mode title (top blue bar) of the home screen. Table 12 lists pre-start alert and alarm conditions.

The compressor RUN STATUS parameter on the default screen line now reads PRESTART. If a test is not successful, the start-up is delayed or aborted. If all tests are successful, the chilled water pump relay energizes, and the main screen line now reads STARTUP.

Table 11 — Compressor Run Status

STATUS NO.	STATUS NAME	DESCRIPTION
0	OFF	STATSTOP is STOP, no alarm.
1	CTLTEST	Controls Test is active.
2	PUMPDOWN	Pumpdown is active.
3	LOCKOUT	Lockout is active.
4	RECYCLE	Recycle shutdown completed on low load in effect until the need for cooling resumes; non-fault condition.
5	TRIPOUT	Shutdown completed due to alarm fault condition.
6	TIMEOUT	The controller is delaying the start sequence until the Start to Start or Stop to Start timers have elapsed.
7	PRESTART	The chiller is in the process of system checking before energizing the compressor motor.
8	STARTUP	Normal start-up in progress.
9	AUTORST	Auto Restart in progress.
10	RAMPING	Ramp loading in progress. The chiller has started and is gradually increasing its load to control electrical demand charges.
11	RUNNING	The chiller has completed ramp loading following start-up. Normal running mode, no override or demand limit.
12	OVERRIDE	Running with Override active.
13	DEMAND	Running with Demand Limit active. The chiller is prevented from loading further because it has reached an AVERAGE LOAD CURRENT limit or a MOTOR KILOWATTS limit.
14	SHUTDOWN	Compressor shutdown in progress.
15	FREECOOL	Free Cooling in Progress
16	CONDFLSH	Condenser Flush in Progress (Note: Available for “Marine Option” only).

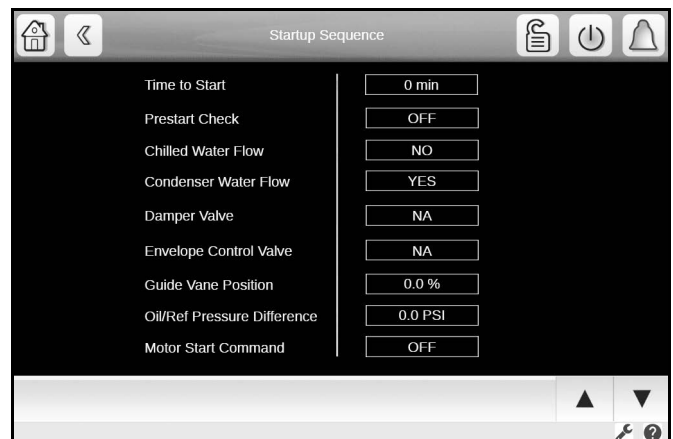

Fig. 30 — Start-Up Sequence Screen

Table 12 — Pre-Start Alerts and Alarms

PRE-START ALERT CONDITION	STATE NO.	ALARM OR ALERT
STARTS IN 12 HOURS >= 8	100	Alert
CONDENSER PRESSURE >= COND PRESS OVERRIDE – 20 psi	102	Alert
Number of recycle restart in the last 4 hours is greater than 5	103	Alert
COMP BEARING TEMP >= COMP BEARING ALERT – 10°F (5.5°C)	230	Alarm
COMP MOTOR WINDING TEMP >= MOTOR TEMP OVERRIDE – 10°F (5.5°C)	231	Alarm
COMP DISCHARGE TEMP >= COMP DISCHARGE ALERT– 10°F (5.5°C)	232	Alarm
EVAP_SAT < Evap trip point* + EVAP OVERRIDE DELTA T or EVAP REFRIG LIQUID TEMP < Evap trip point* + EVAP OVERRIDE DELTA T	233	Alarm
ACTUAL LINE VOLTAGE <= UNDERVOLTAGE THRESHOLD	234	Alarm
ACTUAL LINE VOLTAGE >= OVERVOLTAGE THRESHOLD	235	Alarm
Guide vane 1 has not been calibrated successfully	236	Alarm
Prestart Failure - No Power Supply (If Water Verification Time has passed after Request To Start has been sent and there has not been received a Permission To Start)	237	Alarm
Guide vane 2 has not been calibrated successfully	238	Alarm

* Evap trip point = 33°F (0.6°C) (water) or EVAP REFRIG TRIPPOINT (brine).

START-UP

One second after the successful pre-start check, the chilled water and condenser water pump relays are energized.

Five seconds later, the control monitors the chilled water and condenser water flow devices and waits until the WATER FLOW VERIFY TIME (service-configured, default 5 minutes) expires to confirm water flow.

After water flow is verified, the water temperature is compared to CONTROL POINT + 1/2 CHILLED WATER DEADBAND. If the temperature is less than or equal to this value, the control turns off the condenser pump relay and goes into RECYCLE mode.

If the RECYCLE condition is not satisfied, the start-up sequence continues and checks the guide vane position. The guide vanes are opened to the initial position specified with GV1 Closure at Startup in the Option Configuration menu.

If an EC/HGBP or economizer damper valve is equipped and enabled, the control checks that the position of these valves is fully closed.

If the vanes and valves positions are verified and the refrigerant pump pressure difference is less than 2.5 psi (17.2 kPa), the refrigerant pump relay is energized.

The control then waits the operator-configured verification time (default 40 seconds) for the refrigerant pressure difference to reach 12 psi. After the refrigerant pressure is verified, the control waits 20 seconds for prelube, and after achieving and maintaining the refrigerant pressure, the compressor start relay energizes to start the compressor.

Chiller Shutdown Sequence

Chiller shutdown begins if any of the following occurs:

- Local OFF button is pressed
- A RECYCLE condition is present (see the previous section)
- The time schedule has gone into unoccupied mode when in either Network or Local Schedule control mode
- The chiller protective limit has been reached and chiller is in alarm
- The start/stop status (CHIL_S_S) is overridden to stop from the network when in Network mode

If the chiller is normally shut down from running, a soft-stop shutdown will be performed. The soft-stop feature closes the guide vanes of the compressor automatically if a non-alarm stop signal occurs before the compressor motor is deenergized.

Any time the compressor is directed to STOP (except in the cases of a fault shutdown), the guide vanes are directed to close and VFD will be commanded to minimum speed for a variable speed compressor. The compressor shuts off when any of the following is true:

- PERCENT LOAD CURRENT (%) drops below the SOFT STOP AMPS THRESHOLD
- ACTUAL GUIDE VANE POSITION drops below 4%
- Four minutes have elapsed since the stop was initialized

When any of these conditions is true, the shutdown sequence stops the compressor by deactivating the compressor start relay. The guide vanes are then commanded to the fully closed position. The refrigerant pump relay will be turned off after 120 seconds post-lube.

Finally, the chilled water/brine pump and condenser water pump are shut down.

Refrigerant Lubrication Control

The lube sled assembly under the 19DV condenser barrel manages the lubricating refrigerant supply to the compressor bearings. As part of startup/shutdown, 19DV goes through the stages identified in Table 13.

Essentially the evaporator and condenser control valves are positioned to charge the high side float chamber with liquid refrigerant from the cooler or to supply liquid refrigerant to the bearings from the high side float chamber.

For startup the refrigerant pump delta difference must at least be 8 psig (55.2 kPa).

If it is the first time that the unit is being started, then the controls will perform a 30 minute pre-lubrication. Status flag for this is found in the Quick Calibration menu. The refrigerant pump relay is always ON when the compressor is running.

Table 13 — Lube Assembly Control Valve (CV)

STATUS	CONTROL VALVE		DESCRIPTION
	EVAPORATOR	CONDENSER	
CHILLER OFF	Close	Close	Chiller is off - a start is to be initiated to change state.
PRE-START	Close	Open	Refrigerant pump turns on if pump differential pressure is less than 5 psig - if differential pressure higher Alarm 285 will be displayed.
PRE-CHARGE	Close	Open	Objective is the charge the high side float with refrigerant. If high side float chamber level switch is not closed the refrigerant will be pumped from the evaporator to the high side float chamber until the high side float chamber level switch is satisfied. If level switch is not closed after 10 minutes alert 163 will be active and startup will stop. Once high side float chamber switch is satisfied the pre-charge process pumping liquid to the high side float chamber will continue for 1 minute.
PRE-LUBE	Open	Close	Upon completion of the pre-charge state the controls will verify that the pump refrigerant differential pressure is greater than the limit (typically 8 psig). If not alarm 285 will be activated. Pre-lube will provide refrigerant to the compressor bearings from the high side float chamber. Its duration is 10-20 seconds.
COMPRESSOR RUN	Open	Close	Refrigerant pump is continuously on and refrigerant is provided to compressor bearings from high side float chamber.
POST-LUBE	Close	Close	Upon compressor stop a post-lube cycle of 30 seconds is completed before the refrigerant pump is stopped. During post-lube the bearings are supplied with refrigerant from the evaporator.

NOTES:

1. Upon completion of post-lube the chiller is off and the sequence can be started over.
2. Evaporator Control Valve:
Close = source refrigeration pump from high side float chamber
Open = source refrigeration pump from evaporator

3. Condenser Control Valve:

- Close = refrigerant pump discharge to compressor bearings
- Open = refrigerant pump discharge to high side float chamber

Control Points

SET POINT

The set point can be configured at the Setpoint menu (“USER” access level).

The set point is determined by the heat/cool mode, EWT (entering water temperature) option, and ice build option. See Table 14.

Table 14 — Set Point Determination

EWT CONTROL OPTION	HEAT/COOL MODE	
	COOLING	HEATING
Disabled	Cooling LCW Set Point	Heating LCDW Set Point
Enabled	Cooling ECW Set Point	Heating ECDW Set Point

NOTES:

1. The ice build option is disabled when heat/cool mode is set to Heating.
2. When the ice build option is enabled and ice build is active, the control point is the Ice Build Set Point and the controlled water temperature is the leaving chilled water temperature.

CONTROL POINT TEMPERATURE

Capacity control is based on achieving and maintaining a control point temperature, which is the sum of a valid set point (from the SETPOINT screen) and a temperature reset value. In Cooling mode, the control point temperature is equal to the set point plus temperature reset. In Heating mode, the control point temperature is equal to the set point minus temperature reset.

The control point can be viewed directly on the main screen or the General Parameters menu.

TEMPERATURE RESET

Three types of chilled water or brine reset are available and can be viewed or modified on the Reset Configuration screen.

The default screen indicates when the chilled water reset is active. The control point Reset on the General Parameters screen indicates the amount of reset.

To activate a reset type, access the Reset Configuration (RESETCFG) screen and input all configuration information for that reset type.

Reset Type 1: 4 to 20 mA Temperature Reset

Reset Type 1 is an automatic reset utilizing a 4 to 20 mA analog input signal provided from any external sensor, controller, or other device which is appropriately configured. For this type, Degrees Reset At 20 mA is configured in the RESETCFG table.

Reset Type 2: Remote Temperature Reset

Reset Type 2 is an automatic water temperature reset based on a remote temperature sensor input signal. This function can be accessed by setting the following configurations:

1. Configure the remote temperature at which no reset occurs (**Remote temp → NO RESET**).
2. Configure the remote temperature at which full reset occurs (**Remote temp → FULL RESET**).
3. Enter the amount of reset (Deg Reset Water DT Full).

Reset Type 3: Controlled Water Temp Delta Reset

Reset Type 3 is an automatic controlled water temperature reset based on heat exchanger temperature difference. This function can be accessed by setting the following configurations:

1. Configure the controlled water temperature delta T at which no reset occurs (**Controlled Water DELTA T → NO RESET**).
2. Configure the controlled water temperature delta T at which full reset occurs (**Controlled Water DELTA T → FULL RESET**).
3. Enter the amount of reset (Deg Reset Water DT Full).

CAPACITY CONTROL

Capacity control provides chilled or condenser water temperature control by modulating the position of the inlet guide vane 1 and VFD speed for variable speed compressors.

For 19DV when increased capacity is needed, the control will first try to increase IGV TARGET POSITION if it has not reached the travel limit; if the travel limit has been reached, the control increases VFD TARGET SPEED. If decreased capacity is needed, the control first tries to decrease VFD TARGET SPEED if it has not reached the minimum VFD speed; if the minimum VFD speed has been reached, the control decreases IGV TARGET POSITION instead. See Fig. 31.

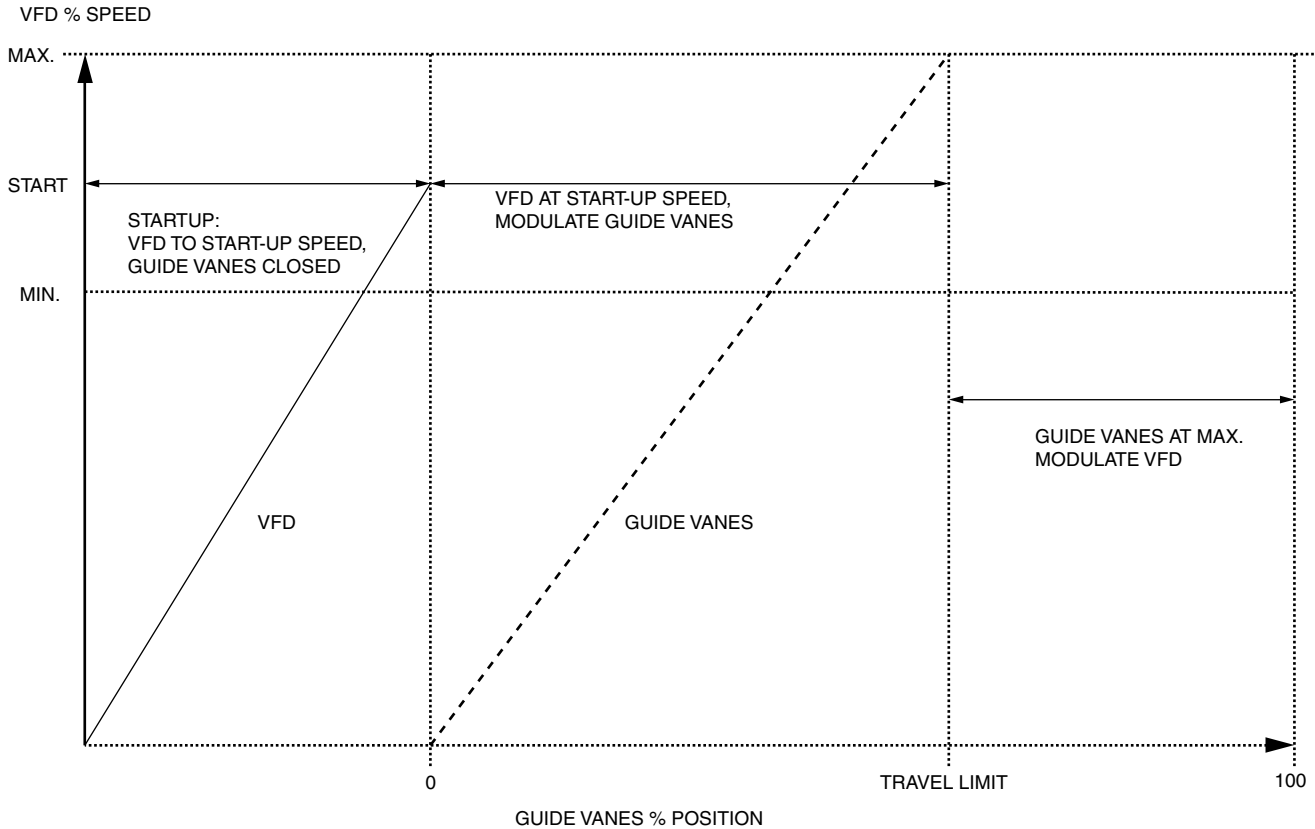

Fig. 31 — Guide Vane Position and VFD Speed

From the compressor relay closed point to the end of ramp loading, the VFD TARGET SPEED is the configured VFD start-up speed. When the chiller is running normally, the capacity control determines whether and how much to change VFD TARGET SPEED. When the chiller is in the shut-down process, VFD TARGET SPEED will be the minimum VFD speed.

NOTE: If the VFD option is set to NO VFD, or the compressor relay is not closed, VFD TARGET SPEED will be 0.

The guide vane position is determined by the Capacity Control function under normal conditions and other functions in abnormal conditions, which include capacity inhibit request or capacity decrease request. The guide vane actuator is driven by comparing the guide vane target position and the actual position. Guide vane position is limited to a value between zero and IGV Travel Limit, which is configured from the Service Configuration menu. When the chiller is shutting down or off, the guide vane is always driven to zero during normal shutdown. Guide Vane 2 is forced based on linear interpolation of set points based on Guide Vane 1 position (see 19DV Configuration).

RAMP LOADING

The ramp loading control slows the rate at which the compressor loads up. This control can prevent the compressor from loading up during the short period of time when the chiller is started and the chilled water loop has to be brought down to CONTROL POINT (Setpoint Table). Ramp loading helps reduce electrical demand charges by slowly bringing the chilled water to CONTROL POINT. The total power draw during this period remains almost unchanged. If the power outage lasts for more than 3 hours, then Temperature Ramp Loading will be used regardless of user configuration and the minimum loading rate (1°F/min) will be used.

Two methods of ramp loading are available: temperature ramp loading and motor load ramp loading.

Temperature Ramp Loading

Temperature ramp loading limits the rate at which the controlled water temperature decreases for cooling and increases for heating during ramping by reducing on cooling mode or increasing in heating mode the PULLDOWN SET POINT (*Maintenance Menu* → *Capacity*) at the configured rate, until the pulldown set point is less than the cooling mode control point or greater than the heating mode control point. The PULLDOWN RAMP TYPE (*Configuration Menu* → *General Configuration*) is configured to 0 for temperature ramp loading.

Motor Load Ramp Loading

Motor load ramp loading limits the rate at which either the load current percentage or motor kilowatt percentage increases by incrementing the ramp demand limit at the configured rate. The PULLDOWN RAMP TYPE (*Configuration Menu* → *General Configuration*) is configured to 1 for motor load ramp loading.

If DEMAND LIMIT SOURCE (*Configuration Menu* → *General Configuration*) is set to AMPS, then PERCENT LOAD CURRENT is used for motor load ramp loading. If DEMAND LIMIT SOURCE is set to kW, then MOTOR PERCENT KILOWATTS is used for motor load ramp loading.

The motor load ramp loading algorithm shall be deactivated when the Ramp Demand Limit is greater than or equal to the ACTIVE DEMAND LIMIT (General Parameters). It is also deactivated when Ramp Demand Limit is greater than or equal to 80%. There will be a one-minute delay for the compressor to be uploaded to target load (ramping load target 80% or ACTIVE DEMAND LIMIT if less than 80%) after ramping load demand limit is set to 80% (or ACTIVE DEMAND LIMIT if less than 80%).

SURGE CORRECTION CONTROL

There are two stages for surge correction: envelope control (surge prevention) and surge protection.

Envelope Control

A surge condition occurs when the lift becomes so high that the gas flow across the impeller reverses. This condition can eventually cause compressor damage. The surge prevention algorithm notifies the operator that chiller operating conditions are marginal and to take action, such as lowering entering condenser water temperature, to help prevent compressor damage.

If a high sound condition occurs at low guide vane position, the EC/HGBP (Envelope Control/Hot Gas Bypass) valve is used to decrease the sound level. The envelope control algorithm is an operator-configurable feature that can determine if lift conditions are too high for the compressor and then take corrective action. High efficiency mode or low noise mode can be selected. Lift is defined as the difference between the saturated temperature at the impeller eye and at the impeller discharge. The maximum lift a particular impeller wheel can perform varies with the gas flow across the impeller and the size of the wheel.

If Actual Lift is higher than reference lift, a capacity inhibit signal will be sent. If Actual Lift is higher than reference lift plus Envelope High Deadband, a capacity decrease signal will be sent. If Actual Lift is lower than reference lift minus Envelope Low Deadband, these 2 signals will be canceled. Capacity Control will respond to these 2 signals and make correction on IGV1 TARGET POSITION, VFD TARGET SPEED, and EC/HGBP actuator. To improve system performance SURGE PROFILE OFFSET will be incremented by 1 if no surge prevention has been active in the past 5 minutes. The Reference Lift will subtract the SURGE PROFILE OFFSET prior to comparing to Actual Lift.

Surge Protection

The Surge Protection algorithm will run after SURGE DELAY TIME has elapsed when compressor has been commanded to turn on. It compares the present PERCENT LOAD CURRENT value with the previous value once every second. If the difference exceeds the maximum AMPS change value (SURGE DELTA % AMPS + [PERCENT LINE CURRENT / 10]), an incidence of surge has occurred, and the surge protection signal will be sent.

When an incidence of surge determined in this manner has occurred, the SURGE COUNTS will be incremented by one. On receiving the surge protection signal, Capacity Control will make corrections on IGV1 TARGET POSITION, VFD TARGET SPEED, and EC/HGBP actuator. When correction is in effect, Surge Protection Count will increase by 1 when a command for either IGV decrease, VFD speed increase, or EC/HGBP actuator activation is required for correction. Guide vane movement will be inhibited for 1 minute after surge protection ends.

Chiller will do 259 Alarm shutdown under the following conditions.

- If Surge Protection Counts exceed 20 within a Surge Time Period. Note that if VFD, then VFD target speed must equal max before this alarm is activated.
- If IGV, VFD, and HGBP cannot be further adjusted for surge protection when Surge Protection Counts exceed 4 within a Surge Time Period.

If IGV, VFD, and HGBP control cannot correct the problem, the chiller will initiate a shutdown alarm when the surge count is greater than 4.

ENVELOPE/HOT GAS BYPASS (HGBP) CONTROL

This function is used to artificially load the chiller and keep it running under low load conditions or to prevent surge conditions. Since this also reduces the performance of the machine, EC/HGBP Control is a user-selectable option.

The EC/HGBP control valve is a modulating type controlled by a 4 to 20 mA signal.

Envelope/hot gas bypass operation has three different modes when installed (hgbp_opt > 0) and enabled (hgbp_sel > 0):

- Envelope control and surge protection — Each compressor has unique lift characteristics that can be plotted to determine performance. The controller will determine operating conditions that could result in compressor surge and activate the bypass valve to prevent surge until the chiller operating parameters are in a safe area on the curve where the valve may be closed again.
- Envelope (HGBP) low load operation — In this condition, the valve will be opened to prevent a recycle shutdown from occurring. The valve will remain open until this minimal loading condition has passed and there is no surge condition present.
- Combination for envelope control and surge correction, as well as low load operation — When this option is selected, both EC for envelope control/surge protection and EC for low load operation will be performed. Surge protection will take higher priority if both conditions are satisfied.

DEMAND LIMIT

The PIC6 controls provide a feature for limiting AVERAGE LOAD CURRENT or MOTOR KILOWATTS by limiting capacity via guide vane control/VFD control. The limit may be applied in two ways. The first is called ACTIVE DEMAND LIMIT, which is equal to a BASE DEMAND LIMIT value (set in the SETPOINT screen, default value 100%). ACTIVE DEMAND LIMIT may also be forced to be different from BASE DEMAND LIMIT by manually overriding (forcing) the value via a CCN network device. If the DEMAND LIMIT SOURCE exceeds the ACTIVE DEMAND LIMIT by 5% or less, capacity will be inhibited. If the DEMAND LIMIT SOURCE exceeds the ACTIVE DEMAND LIMIT by more than 5%, capacity will be decreased.

Alternatively, the limit may be applied by AUTO DEMAND LIMIT INPUT, an optional 4 to 20 mA input. This demand limit control option (4 to 20 mA DEMAND LIMIT TYPE) is externally controlled by a 4 to 20 mA signal. The option is set up on the **Configuration Menu** → **GENERAL CONFIGURATION** screen. When enabled, 4 mA will set ACTIVE DEMAND LIMIT to 100% of the DEMAND LIMIT SOURCE (regardless of the value of BASE DEMAND LIMIT), and 20 mA will set ACTIVE DEMAND LIMIT to the value configured for DEMAND LIMIT AT 20 mA in the **Configuration Menu** → **SERVICE PARAMETERS** screen.

OVERRIDE CONTROL

Capacity overrides can prevent some safety shutdowns caused by exceeding the motor amperage limit, evaporator refrigerant low temperature safety limit, motor high temperature safety limit, and condenser high pressure limit. In these cases there are two stages of capacity control:

1. When the value of interest crosses the first stage set point into the override region, the capacity is prevented from increasing further, and the status line on the PIC6 controller indicates the reason for the override. Normal capacity control operation is restored when the value crosses back over the first stage set point, leaving the override region.
2. When the value of interest is in the override region and further crosses the second stage set point, the capacity is decreased until the value meets the override termination condition. The PIC6 controls resume normal capacity control operation after the override termination condition has been satisfied. (In the case of high discharge superheat, there is an intermediate stage.)

Table 15 summarizes these override parameters.

Table 15 — Override Parameters

OVERRIDE CONDITION	OVERRIDE PARAMETER	FIRST STAGE CAPACITY INHIBIT	DEFAULT VALUE/ CONFIGURABLE RANGE	SECOND STAGE CAPACITY DECREASE	OVERRIDE TERMINATION
High condenser pressure override (Unit Type Heat/Cool=1 in Configuration Menu → Factory . Before configuring Unit Type = 1 verify that unit is able to withstand pressure - note all North America units are of 72 PSI design.)	CONDENSER PRESSURE	> COND PRESS OVERRIDE HIGH	55 psig/20 to 56 psig	> COND PRESS OVERRIDE HIGH + 2.4 psi	< COND PRESS OVERRIDE HIGH — 1 psi
High compressor discharge temperature	COMP DISCHARGE TEMP	>COMP DISCHARGE ALERT	200°F/125 to 200°F (93.3°C/51.7 to 93.3°C)		COMP DISCHARGE TEMP <COMP DISCHARGE ALERT-2°F (1.1°C)
High compressor bearing temperature	COMP BEARING TEMP	>COMP BEARING TEMP ALERT DV	104°F/90 to 120°F (40°C/32.2 to 48.9°C)		COMP BEARING TEMP <COMP BEARING TEMP ALERT DV-2°F (1.1°C)
Low evaporator temperature override	CALC EVAP SAT TEMP or EVAP REFRIG LIQUID TEMP	< EVAP SAT OVERRIDE TEMP (EVAP SAT OVERRIDE TEMP = EVAP TRIP-POINT + EVAP OVERRIDE DELTA T)		< EVAP SAT OVERRIDE TEMP - 1°F (0.56°C)	> EVAP SAT OVERRIDE TEMP + 2°F (1.1°C)
High motor temperature override	COMP MOTOR WINDING TEMP	> COMP MOTOR TEMP OVERRIDE	200°F/150 to 200°F (93.3°C/65.6 to 93.3°C)	COMP MOTOR WINDING TEMP > COMP MOTOR TEMP OVERRIDE + 10°F (5.6°C)	COMP MOTOR WINDING TEMP < COMP MOTOR TEMP OVERRIDE - 2°F (1.1°C)
Rectifier Overload (32VS VFD only)	RECTIFIER OVERLOAD	>100%		>102%	<98%
High current override	PERCENT LINE CURRENT	PERCENT LINE CURRENT > 100%		PERCENT LINE CURRENT > 105%; 102% WHEN 32VS VFD INSTALLED	PERCENT LINE CURRENT <= 100%
Low discharge superheat override	Discharge Superheat (DSH)	< DSH REQUIRED + 1		< DSH REQUIRED -3	> DSH REQUIRED + 2
Low source temperature protection override	Leaving water temperature (heating mode)	< LWT PROTECTION SETPOINT - 2°F (1.1°C)			>LWT PROTECTION SETPOINT + 0.5°F (0.3°C)

Other types of override events do not override control guide vane or VFD operation, but are reported:

- High compressor discharge temperature override — If the COMP DISCHARGE TEMP is greater than the COMP DISCHARGE ALERT threshold, then high discharge temperature override will be displayed in the main screen until the COMP DISCHARGE TEMP is less than the COMP DISCHARGE ALERT threshold - 2°F (1.1°C).
- High compressor bearing temperature override — If one of the compressor bearing temperatures is greater than the compressor bearing temperature Alert (**Configuration Menu** → **Protective Limit Config**) threshold, then High Bearing Temp Override shall be active until all of the compressor bearing temperatures are less than Comp Bearing Temp Alert minus 2°F (1.1°C).
- Low Discharge Superheat Temperature Override — This override is ignored during the first 5 minutes after chiller start-up.

RECYCLE CONTROL

The chiller may cycle off and wait until the load increases to restart when the compressor is running in a lightly loaded condition. This normal cycling is known as “recycle.”

In cooling mode, a recycle shutdown is initiated when either of the following conditions is true:

- Leaving chilled water temperature (or entering chilled water temperature, if the EWT CONTROL OPTION is enabled) is more than 5°F (2.8°C) below the CONTROL POINT.
- Leaving chilled water temperature (or entering chilled water temperature, if the EWT CONTROL OPTION is enabled) is below the CONTROL POINT, and the chilled water temperature difference is less than the RECYCLE SHUTDOWN DELTA T.

In heating mode, a recycle cycle shutdown occurs when either of the following conditions is true:

- Leaving condenser water temperature (or entering condenser water temperature, if the EWT CONTROL OPTION is enabled) is more than 5°F (2.8°C) below the CONTROL POINT.
- Leaving condenser water temperature (or entering condenser water temperature, if the EWT CONTROL OPTION is enabled) is above the CONTROL POINT, and the condenser water temperature difference is less than the RECYCLE SHUTDOWN DELTA T.

NOTE: Recycle shutdown will not occur if the CONTROL POINT has been changed by more than 1°F (0.56°C) within the previous 5 minutes of operation.

When the chiller is in RECYCLE mode, the chilled water pump relay remains energized so the chilled water temperature can be monitored for increasing load. The recycle control uses RECYCLE RESTART DELTA T to check when the compressor should be restarted. In cooling mode, the compressor will restart when the leaving chilled water temperature (or entering chilled water temperature, if the EWT CONTROL OPTION is enabled) is greater than the CONTROL POINT plus the RECYCLE RESTART DELTA T for 5 consecutive seconds. In heating mode, the compressor will restart when the leaving condenser water temperature (or entering condenser water temperature, if the EWT CONTROL OPTION is enabled) is less than the CONTROL POINT minus the RECYCLE RESTART DELTA T for 5 consecutive seconds.

RUNNING TIMERS AND COUNTERS

The PIC6 control maintains two run-time clocks: COMPRESSOR ONTIME and SERVICE ONTIME. COMPRESSOR ONTIME indicates the total lifetime compressor run hours. SERVICE ONTIME is a resettable timer that can be used to indicate the hours since the last service visit or any other event. A separate counter tallies compressor starts as TOTAL COMPRESSOR STARTS.

All of these can be viewed on the RUN TIMES screen. Both On-time counters roll over to 0 at 500,000 hours. Manual changes to SERVICE ONTIME from the screen are permitted at any time. If the controller is replaced, one opportunity before the first start-up with the new controller is provided to set COMPRESSOR ON-TIME and TOTAL COMPRESSOR STARTS to the last readings retained with the prior controller.

The chiller also maintains a start-to-start timer and a stop-to-start timer. These timers limit how soon the chiller can be started and are displayed on the system overview (home) and RUN TIMES screens. They can be configured in the **Configuration Menu** → **GENERAL CONFIGURATION** screen. They must expire before the chiller starts. If the timers have not expired, the RUN STATUS parameter on the System Overview (Home) and GENERAL PARAMETERS screen reads TIMEOUT.

WATER PUMPS CONTROL (FREEZE PREVENTION)

NOTE: In order to energize the chilled and condenser pump to prevent evaporator and condenser tube freeze-up, the hydraulic system should be enabled first (this can be configured in the **Configuration Menu** → **FACTORY PARAMETERS** screen).

Evaporator Freeze Prevention

When the evaporator saturated refrigerant temperature or evaporator refrigerant temperature is less than the EVAP REFRIG TRIPPOINT + REFRIG OVERRIDE DELTA T (configurable from 2°F to 5°F (1.1°C to 2.8°C) in the **Configuration Menu** → **PROTECTIVE LIMIT CONFIG** screen), an OVERRIDE—LOW EVAP REFRIG TEMP event will occur.

For any running status, if either of the conditions below is true then unit will shut down under Alarm PROTECTIVE LIMIT - EVAPORATOR FREEZE (State 261):

- Evaporator saturated refrigerant temperature or evaporator refrigerant temperature is equal to or less than the EVAP REFRIG TRIPPOINT (33°F [0.6°C] for water, (configurable for brine in **Configuration Menu** → **PROTECTIVE LIMIT CONFIG** screen) plus 1°F (0.56°C).
- Leaving chilled water temperature or entering chilled water temperature is less than EVAP REFRIG TRIPPOINT plus 1°F (0.56°C).

NOTE: If the chiller is in recycle mode, it will transition to TRIPOUT, and the CHILLED WATER PUMP will remain on.

The alarm will be clearable when the evaporator saturated refrigerant temperature, evaporator refrigerant temperature, leaving chilled water temperature, and entering chilled water temperature rise 5°F (2.8°C) above the EVAP REFRIG TRIPPOINT.

Condenser Pump Control

The chiller will monitor the condenser pressure and may turn on the condenser pump. If the condenser pressure is greater than or equal to the COND PRESS OVERRIDE, and the entering condenser water temperature is less than 115°F (46.1°C), the condenser pump will energize to try to decrease the pressure and Process Alert - High Condenser Pressure Chiller Off (Alert 157) will be generated. The pump will turn off when the condenser pressure is 3.5 psi (24.1 kPa) less than the pressure override and the condenser refrigerant temperature is less than or equal to the entering condenser water temperature plus 3°F (1.7°C).

NOTE: COND PRESS OVERRIDE is found in the **Configuration Menu** → **PROTECTIVE LIMIT CONFIG** screen.

Condenser Freeze Prevention

This control helps prevent condenser tube freezing by energizing the condenser pump relay. The PIC6 module controls the pump and, by starting it, helps to prevent the water in the condenser from freezing.

When the chiller is off and condenser saturated refrigerant temperature is less than or equal to the condenser freeze point, the condenser water pump will be energized (Alarm State 262,

PROTECTIVE LIMIT - CONDENSER FREEZE). The fault state will clear and the pump will turn off when the condenser saturated refrigerant temperature is more than 5°F (2.7°C) above the condenser freeze point and the entering condenser water temperature is greater than the condenser freeze point. If the chiller is in recycle shutdown mode when the condition occurs, the controls will transition to a non-recycle shutdown.

CONTROL TEST

This feature allows the operator to quick-test the controls and related hardware, including all unit-controlled outputs except compressor output.

The unit must be off to run the test function. If the unit is on, the test function cannot be accessed. The compressor can only be started after the control test is finished. The test function also requires the user to enter the User password if it has not already been entered. All control test parameters are accessible through the Quick Test table. To perform the control test function, set the first item Quick Test Enable in the Quick Test table to Enable.

Unless otherwise noted, all protective limits remain active during the controls test.

Discrete Outputs

When the control test is enabled, discrete outputs can be enabled using the Quick Test table. Discrete valves that can be tested in Quick test are: GV1 Open, GV1 Close, Refrigerant Pump Relay, Condenser Pump Relay, Evaporator Pump Relay, Alarm Relay, and Alert Relay.

NOTE: For refrigerant pressure, a value ≥ 10 psi within 15 seconds after the refrigerant pump is turned on indicates a confirmation of pressure.

Analog Output

When the control test is enabled, the following analog outputs can be enabled by entering the positions in the QCK_TST table:

- Head Pressure Valve
- Chiller Status Output (Q_CHST)

Guide Vane Calibration

The guide vane position should be calibrated before starting the chiller. Guide vane calibration can be started by setting Quick Test Enable to Enable and GV1/GV2 Calibration Enable to Enable.

- The fully closed guide vane feedback mA value will be in the range of 3 mA to 5 mA.
- The fully opened guide vane feedback mA value will be in the range of 19 mA to 20.8 mA.

MOTOR ROTATION CHECK

The motor rotation check should be initiated before starting the chiller. Motor Rotation Check can be performed by setting Quick Test Enable to Enable; check proceeds as follows. Note that operator must verify clockwise rotation through first stage suction pipe sightglass.

- Fully open GV1
- Open evaporator control valve and condenser drain valve, close condenser control valve and evaporator control valve. Run the refrigerant pump for 30 seconds
- Start the motor and ramp to 5Hz in 10 seconds
- Stop the motor once its speed reaches 5Hz
- Stop the refrigerant pump 1 minute after the motor speed reaches 5Hz. Reset all 4 refrigerant lubrication valves to close
- Close GV1 3 minutes after the motor speed reaches 5Hz

SWIFT RESTART (CAPACITY RECOVERY™)

This function is designed for data center or other applications. It allows the chiller to be restarted quickly to meet building load requirements.

To enable this function, the AUTO RESTART OPTION point in the CONF_OPT table should be set to ENABLE.

The water flow verification time, refrigerant prelube time and other delays will be decreased compared to a normal start-up.

COOLING TOWER CONTROL

For chiller cooling tower fan control a fourth optional hydraulic control I/O board is required with outputs for Tower Fan Low and Tower Fan High cooling tower fans.

The cooling tower fans are controlled by the pressure difference between condenser and evaporator and entering water temperature of condenser. The objective is to maintain the entering condenser water temperature in the optimal range.

WATER PUMP CONTROL

Note that chiller must always maintain pump control or warranty may be voided.

HEAD PRESSURE CONTROL

If the chiller system is equipped with a head pressure control valve, and the HEAD PRESSURE VALVE option in the CONF_OPT table is ENABLED, the PIC6 control system will control the opening of the head pressure valve to maintain the pressure difference between condenser and evaporator. The output of this valve is 4 to 20 mA type.

Before using this function, the pressure difference values for 20 mA and 4 mA should be set.

The head pressure valve should be in fully closed position when chiller is in OFF mode.

ICE BUILD OPTION

The PIC6 controller provides an ice build option based on efficiency improving point. The ICE BUILD OPTION in the CONF_OPT table should be set to ENABLED to make ice build active, and the following two parameters should be configured:

- Ice_recy (ICE BUILD RECYCLE) indicates whether recycle option is enabled in ice build mode.
- Ice_term (ICE BUILD TERMIN SOURCE) indicates how the ice build is terminated. There are three types: temperature (0), dry contact (1), or combined temperature and dry contact (2).

TIME SCHEDULE

The PIC6 control provides three schedules:

- Local schedule
- Ice build schedule
- Network schedule

Each schedule has 8 time segments. If two time segments overlap, the unoccupied time segment takes priority.

There are 16 holiday time segments. Each holiday time segment is determined by three parameters—month, start date, and holiday days. The controller will be in unoccupied mode when a holiday time segment is active. PIC6 includes a Daylight Savings Time function. Use Broadcast Menu to enable this feature and configure start and end dates.

BLACK BOX

The black box task continuously stores parameters in memory every 5 seconds. Reporting of a chiller operation alarm triggers the controller to generate a collection of data records. Each collection contains up to 180 records that consist of 168 records (corresponding to 14 min.) before the alarm and 12 records (corresponding to 1 min.) after the alarm. Each record is associated with a time stamp. Files are saved as csv files; up to 20 files can be stored.

The black box file can be uploaded with the Carrier Service Tool. Once the upload is done, the original files are automatically deleted.

Black box data is only available for the following alarms:

Alarm #	Alarm Description
253	PROTECTIVE LIMIT - HIGH DISCHARGE TEMP
254	PROTECTIVE LIMIT - LOW EVAP REFRIGERANT TEMP
255	PROTECTIVE LIMIT - HIGH MOTOR TEMPERATURE
256	PROTECTIVE LIMIT - HIGH BEARING TEMPERATURE
257	PROTECTIVE LIMIT - HIGH CONDENSER PRESSURE
259	PROTECTIVE LIMIT - EXCESSIVE COMPRESSOR SURGE
260	PROTECTIVE LIMIT - COMP START RELAY START FAILURE
261	Protective Limit - Potential Evaporator Freeze-up
262	Protective Limit - Potential Condenser Freeze-up
267	PROTECTIVE LIMIT - GUIDE VANE 1 FAULT
285	PROTECTIVE LIMIT - LOW BEARING DELTA PRES DIFFERENCE
286	PROTECTIVE LIMIT - LOW LIQUID LEVEL IN HIGH FLOAT VLV
295	PROTECTIVE LIMIT - HIGH BEARING INLET TEMPERATURE

PRESSURE TRANSDUCER CALIBRATION

The HMI pressure readings are displayed in the *Main Menu* → *Pressures* screen. See Fig. 32.

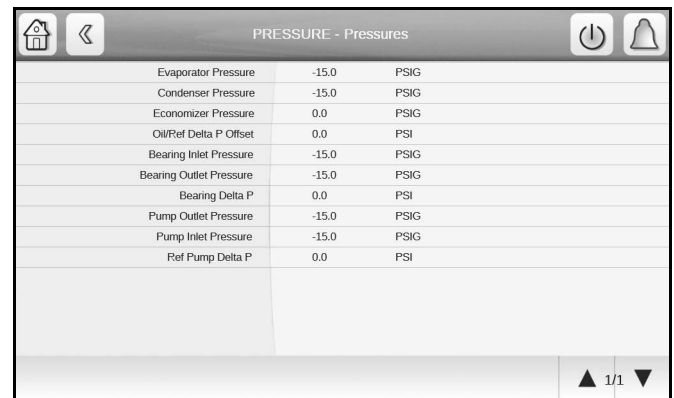

Fig. 32 — Pressures Screen

Once a year the pressure transducers should be checked against a pressure gage. Attach a set of accurate refrigeration gages to the transducer being checked and compare the two readings. If there is a difference the transducer can be calibrated as described below. Calibration requires Service level access to the HMI.

NOTE: It is usually not necessary to calibrate at initial start-up unless chiller is at high altitude.

1. Go to *Main Menu* → *Maintenance Menu* → *Pressure Sensor Calib*. See Fig. 33.



Fig. 33 — Pressure Sensor Calib Screen, Page 1

- Each transducer is supplied with 5 vdc from the IOB. Calibration is done by selecting the appropriate Pressure Sensor option on the Pressure Sensor Calib screen. The screen for the selected option is displayed. Figure 34 shows the Evap Pressure Sensor screen (PRSCAL01 as an example).

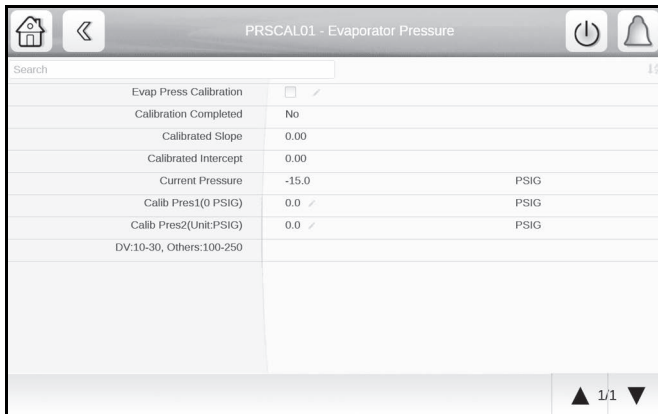

Fig. 34 — Evap Pressure Sensor Screen

- Set Calibration Enable to Enable. Calibration for this sensor is complete and the new slope and intercept will be used for the calibrated transducer in the pressure or temperature tables.
- With the transducer at atmospheric pressure (zero gage pressure), ensure that “Calib Press1 (0 PSI)” = 0 PSIG.
- Pressurize the transducer to a known pressure between 100 and 250 psig, and enter that pressure as read from calibrated gage in the “Calib Press2 (10-30PSI)” field and press “OK.”
- Screen will show “Calibration Completed = Yes” upon successful calibration. To exit, use the arrow key or click the Home button.

TEMPERATURE SENSOR CALIBRATION

The four water temperature sensors can be separately calibrated to have their temperature readings offset by a specified amount. Follow these steps for each sensor:

- Go to **Main Menu** → **Maintenance Menu** → **Temp Sensor Calib**. See Fig. 35 and 36.

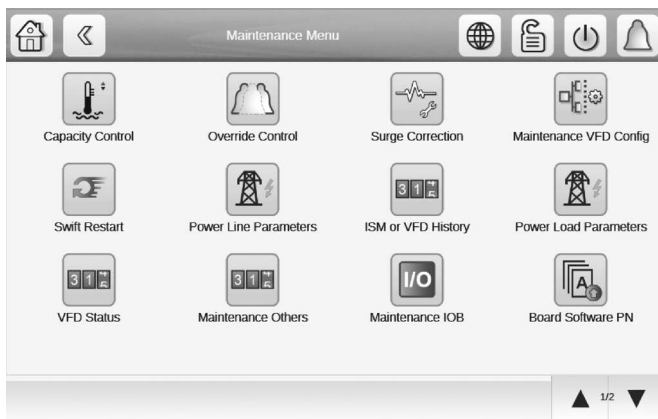

Fig. 35 — Maintenance Menu Calibration, Page 1

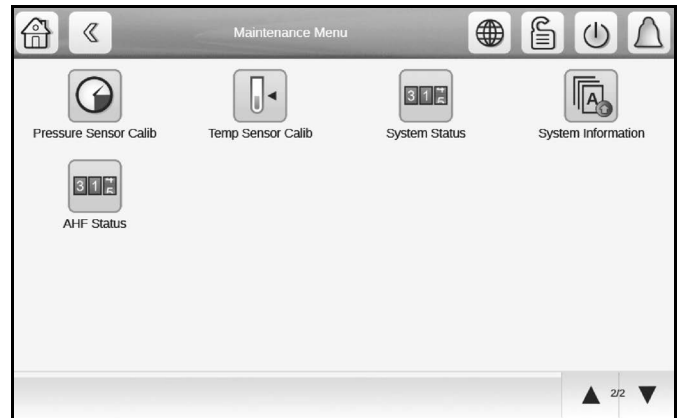

Fig. 36 — Maintenance Menu Calibration, Page 2

- Place the temperature sensor in a 32°F (0°C) water solution.
- Read the sensor raw temperature on the Maintenance screen.
- Calculate the offset to be applied as follows:
 $32 - \text{sensor raw temp } (^{\circ}\text{F})$
 Example:
 ECW sensor raw temperature reads 32.6°F.
 ECW temperature offset must be set to -0.6°F
 $(32 - 32.6 = -0.6)$
- In the Temp Sensor Calib screen, enter the temperature offset for the appropriate sensor as calculated in Step 4. See Fig. 37.

NOTE: The offset cannot exceed ± 2°F (1.1°C).

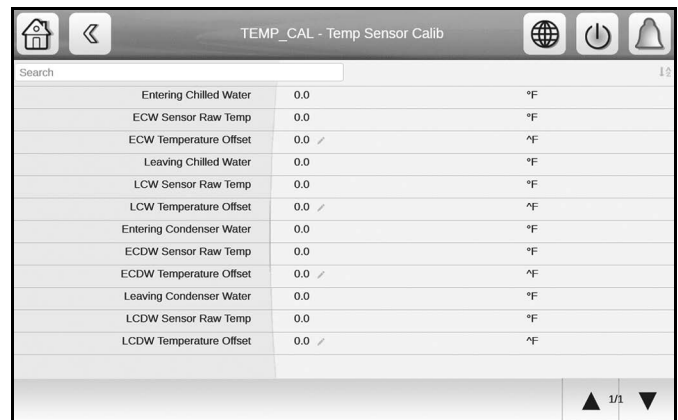

Fig. 37 — Temp Sensor Calib Screen

- Verify that the measured temperature value is the same as the controlled temperature.

ALARM EMAIL

The alarm email function sends automatic email messages to specified service personnel for remote maintenance purposes. This function can be set up from the second page of **Configuration Menu** → **E-Mail Configuration** (EMAILCFG). Subsequently if there is an alarm the function will send an e-mail message. Another message is sent when all alarms return to normal. See Fig. 38 and 39.

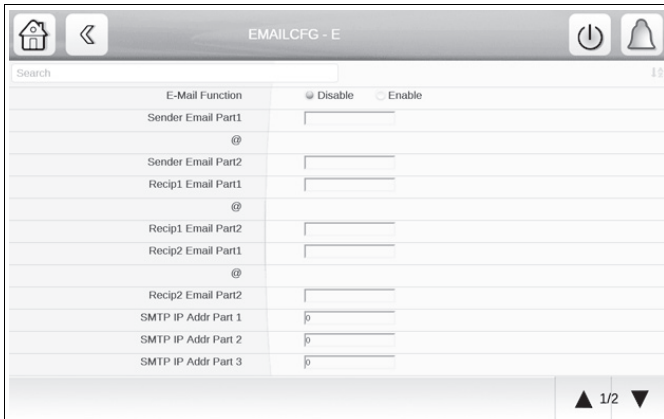

Fig. 38 — E-Mail Configuration Screen, Page 1

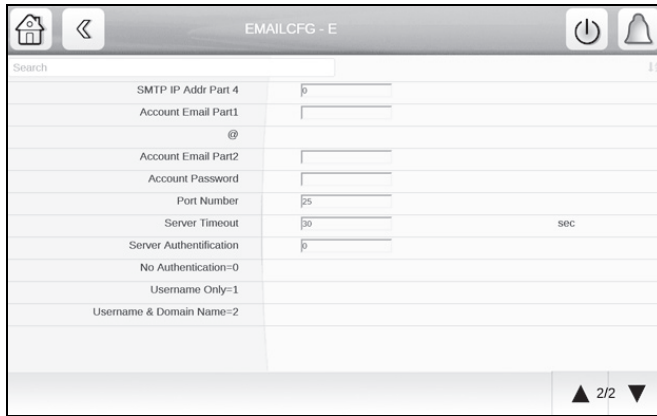

Fig. 39 — E-Mail Configuration Screen, Page 2

The alarm task runs periodically. At each alarm task run time, the status change of each alarm is checked and one email message is sent to each specified recipient when one or more alarms are switched on. When all alarms return to normal, another e-mail message is sent to remote maintenance service personnel.

The e-mail message provides the unit description and location stored in the CTRL_ID table, available from the CONFIGURATION menu. See Fig. 40.



Fig. 40 — CTRL_ID Screen

MASTER SLAVE CONTROL

This control, available from page 2 of the Configuration Menu, provides the capability to operate 2 chillers in Master/Slave mode. The slave chiller should be set to NETWORK mode and controlled by the master chiller.

The two chillers can be configured to be in parallel or in series. When they are in series mode, the master chiller's evaporator must be downstream. The lead chiller shall always be started first, and the lag chiller shall be maintained at zero percent capacity. When the lead chiller cannot be loaded anymore, then the lag start timer is started. The lag chiller shall always be stopped prior to lead chiller.

If a communication failure is detected between the master and the slave chillers, all master/slave functions are disabled and chillers return to stand-alone operations until communication is reestablished. If middle sensor is installed, this, among other things, can be configured in the Master Slave Config table. Figures 41 and 42 show Master/Slave Config options.



Fig. 41 — Master/Slave Config Screen, Page 1

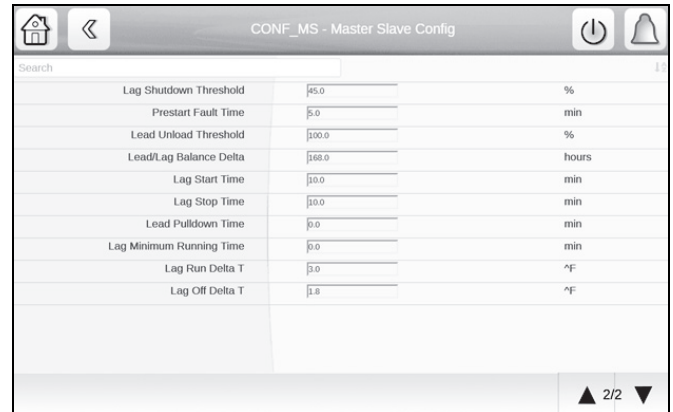

Fig. 42 — Master/Slave Config Screen, Page 2

ECONOMIZER BYPASS

Economizer (liquid) Bypass is an optional piping option where the liquid refrigerant can bypass the economizer. This avoids potential liquid choke and associated condenser liquid stack up and go directly from the condenser to the evaporator. When the liquid bypass is activated and operational the unit will therefore operate as a single stage system. This option increases the operational envelope by lowering the required pressure difference between the evaporator and condenser.

The liquid bypass actuator opens under the following conditions:

Evaporator saturated refrigerant temperature less (Evap Refrig Trippoint + Economizer Liquid Bypass Valve Temp Band) AND cooler approach exceeds (Economizer Liquid Bypass Valve Evap Approach).

OR

Temperature difference between saturated condenser and evaporator is less than (Economizer Liquid Bypass Valve Temp Difference) AND cooler approach is greater than (Economizer Liquid Bypass Valve Evap Approach).

The liquid bypass actuator will return to normal (closed) when the Discharge Superheat is less than Software Required Discharge Superheat plus (Economizer Liquid Bypass Valve Off Discharge).

Figure 43 shows the Liquid Bypass screen.

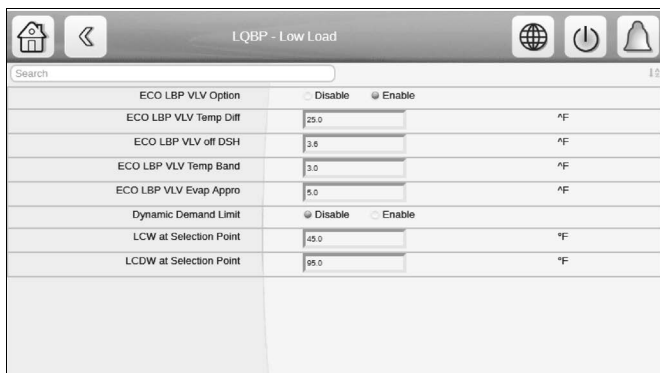

Fig. 43 — Liquid Bypass

Displaying Data Trends

The PIC control system offers the ability to configure and display color-coded system trends without a password. Select **Main Menu** → **Trending**.

On the Trending screen (see Fig. 44), check the data to be tracked, and set the beginning and end points for the selected data. To change a data color, select the colored square and choose a new color from the pop-up color bar. To view data trends, select the down arrow at the bottom right of the Trending screen. The next page displays the selected data in the chosen colors. See Fig. 45.

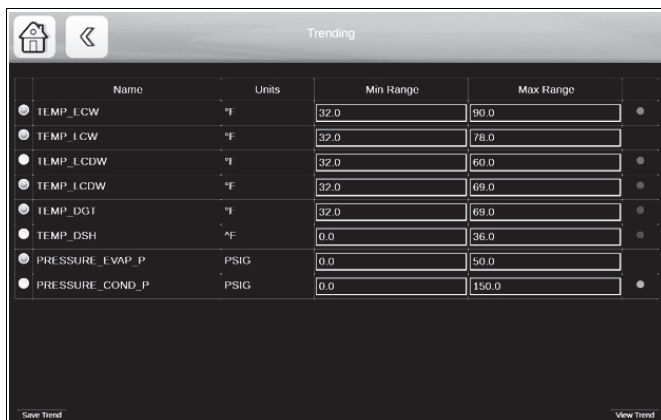

Fig. 44 — Trending Screen Set-Up Page

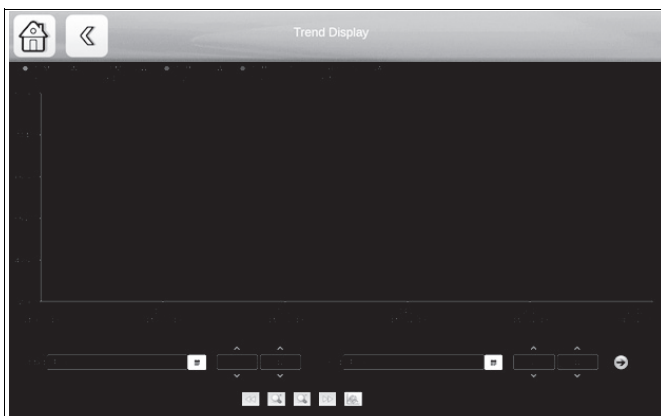

Fig. 45 — Trending Screen Display Page

Hydraulic Option

WATER FLOW MEASUREMENT

The PIC6 controller provides the function of measuring water flow rate.

Equipped with a field installed flow meter, it can compute the water flow rate from the input signal sent from the evaporator/condenser water flow sensor (4 to 20 mA) to the IOB (see Fig. 4, IOB4 wiring schematic).

Step 1: Set **Option2** → **IOB4 Option** as “Yes.”

Step 2: Set **Water Flow Measurement** as “1 = WTR Flow MTR,” and enter the corresponding value of Water Flow [GPM] at 4 mA and 20 mA.

Step 3: In “Hydraulic Status” menu, check evaporator/condenser water flow rate value. (The flow rate value will be linear interpolated by actual reading and configured water flow rate at 4 mA/20 mA.)

Water flow can also be computed from water pressure sensors or water pressure drop sensors (see IOB4 wiring schematic). IOB4 Option must be Enabled in Option 2 Menu and Water Flow Measurement option configured as “2 = WTR Flow PD” and the evaporator/condenser pressure drop baseline and water flow must be entered as inputs.

Additionally the 19DV can be equipped with a normally open flow switch; the evaporator/condenser water flow will indicate the flow status (see IOB1 wiring schematic). In Option 2 **Water Flow Determination** must be set to “1=Flow Switch” for this option to be active.

WATER PRESSURE OPTION

When entering and leaving water pressure transducers (WTR Flow PD TRD) or 4 to 20 mA water pressure differential transducers (WTR Flow PD TRM) are installed, the PIC6 can compute or read the water pressure difference between entering and leaving water pressure, and thereby determine if the water is flowing. After the water pump is switched on, if the water pressure difference reaches the threshold, the water flow check is passed and the chiller can start. Otherwise there will be an alarm shutdown.

Step 1: Set **Option 2** → **IOB4 Option** as “Yes.”

Step 2: Set **Water Pressure Option** as either “1 = WTR Flow PD TRD” or “2 = WTR Flow PD TRM” (4 to 20 mA signal). Note that for Option 2 the Water Pres Drop @ 20 mA must also be set in Option 2 Menu.

Step 3: In “Hydraulic Status” menu, check Condenser Water Delta P, Condenser Water Flow, Evaporator Water Delta P, Evaporator Water Flow.

MARINE OPTION(S)

A marine (shipboard) chiller has different requirements compared with typical chillers.

NOTE: These options are not intended to be used for comfort cooling applications.

Evaporator Approach Calculation

If **Option** → **Evap App Calc Selection** is set to Sat Temp, evaporator approach will be calculated from evaporator leaving water temperature and evaporator saturated temperature.

If this option is set to Ref Temp, evaporator approach will be calculated from evaporator leaving water temperature and evaporator refrigerant temperature.

Free Cooling

If **Option 2** → **Free Cooling** is enabled, any one of the following will make the chiller start free cooling.

- In Network Mode, enable **General Parameters** → **Start Free Cooling** from CCN, BACNet¹, or Modbus².
- Close Free Cooling Start Switch contact. (5TB terminals 65, 66) with field supplied relay.
- Chiller interface (HMI).

When free cooling is in progress, the chiller will take these actions:

- Switch on evaporator and condenser water pump
- Open head pressure valve to maximum opening position
- Open guide vanes to maximum opening position
- Activate free cooling mode output contact (24 VAC on 5TB terminal 67)
- Display Free Cooling mode on the homepage.
- Force liquid bypass valve open
- Fully open free cooling vent valve between evaporator and condenser

Free cooling mode will only be activated when chiller is not running. If the chiller is running, free cooling start request will be ignored. When free cooling is in progress, chiller is not able to start up.

1. BACnet is a registered trademark of ASHRAE (American Society of Heating, Refrigerating, and Air-Conditioning Engineers).
2. Modbus is a registered trademark of Schneider Electric.

DIAGNOSTICS AND TROUBLESHOOTING

The 19DV PIC6 control system has many fault tracing aid functions. The local interface and its various menus give access to all unit operating conditions.

If an operating fault is detected, an alarm is activated. The alarm code is displayed in the Alarms menu, sub-menus Reset alarms and Current alarms. The control may record up to 10 current alarms and alerts.

Alarm/Alert Codes

Table 16 lists PIC6 alert codes. Table 17 lists PIC6 alarm codes. These do not cause machine shutdown and are typically automatically reset when the situation returns to normal.

Displaying Alarms

The alarm icon  on the interface (see the section Icons on page 12) indicates unit status as follows:

- A flashing red LED shows that the unit is operating but there is an alert.
- A steady red LED shows that the unit has been shut down due to a fault.

The Reset Alarms option on the main menu displays up to five alarm codes that are active on the unit. Table 17 lists alarm codes.

Resetting Alarms

When the cause of the alarm has been identified and corrected, the alarm can be reset either automatically or manually (depending on the type of alarm). See Table 17 for alarms that are eligible for automatic reset.

In the event of a power supply interrupt, if Auto Restart Option is set to ENABLE in the Option Configuration menu, the unit restarts automatically without the need for an external command.

A manual reset must be run from the main menu via the Reset Alarms Feature.

Once the alarm has been corrected or reset, all information regarding solved alarms is stored in the Alarm History. Alarm History will store last 50 alarms even after alarms have been corrected or reset.

Table 16 — PIC6 Alert Codes*

ALERT CODE	DESCRIPTION OF ALERT TEXT	CRITERION FOR TRIP	ALERT RESET METHOD	ACTION TAKEN BY THE CONTROL	POSSIBLE CAUSE
Alt-100	Prestart Alert - Starts Limit Exceeded	Tested only on prestart run status, if STARTS IN 12 HOURS >= 8	Automatic when STARTS IN 12 HOURS <8	Turn On Alert Relay	Check STARTS IN 12 HOURS in Run times screen. Enable the "Enable Excessive Starts" option in "service" menu if additional start is required. (Recycle restarts and auto restarts after power failure are not counted.)
Alt-102	Prestart Alert - High Condenser Pressure	Tested only on prestart condition, when ref type is R134a, if CONDENSER PRESSURE >= COND PRESS OVERRIDE - 20 PSI; when ref type is R1233, if CONDENSER PRESSURE >= COND PRESS OVERRIDE	Automatic when the situation comes back to normal	Turn On Alert Relay	Check CONDENSER PRESSURE. Check Condenser Pressure transducer wiring and accuracy. Check for high condenser water temperatures. Check COND PRESS OVERRIDE in configuration
Alt-103	Prestart Alert - Excessive Recycle Starts	If the number of recycle restarts in the last 4 hours is greater than 5	Automatic when the count is less than or equal to 5 in the last 4 hours	Turn On Alert Relay	Chiller load is too low to keep compressor on line and there has been more than 5 starts in 4 hours. Increase chiller load, adjust ecv to open at a higher load, increase recycle RESTART DELTA T in service menu. Check ECV isolation valve position.
Alt-104	Prestart Alert - Waiting For Start Permission	If the POWER REQUEST OPTION is ON, REQUEST TO START has been sent and PERMISSION TO START is not received.	Automatic when startup is aborted or PERMISSION TO START is received	Turn On Alert Relay	Check whether Power Request Option is enabled by mistake. If the ship's power system not receive the power request signal, check the connection of power request output. If the ship's power system does not give the power permission signal, check the ship's power system. If the chiller does not receive the power permission signal, check the connect of power permission input.
Alt-120	Sensor Alert - Remote Temperature Out of Range	Tested when the compressor is on all of the run status, if Temp Reset Type is set as Remote Temp type AND if remote temp sensor is outside range of -39.5 to 244.5°F	Automatic when the situation comes back to normal	Alert Relay is ON	Type 2 Temperature Reset is Enabled and Remote Temperature Reset sensor is out of range. Check ENABLE RESET TYPE and TEMPERATURE RESET settings in TEMP_CNTRL screen. Check Remote Temperature Reset sensor resistance or voltage drop. Check for proper wiring to CCM J4-13 & J4-14.
Alt-121	Sensor Alert - Auto Water Temp Reset	Tested when the compressor is on all of the run status, if Temp Reset Type is set as 4-20mA type AND if auto water temp reset input is less than 2mA	Automatic when the situation comes back to normal	Alert Relay is ON	Check Temp Reset Configuration Confirm that Auto Water Temp Reset Input is between 4 mA and 20 mA. Confirm that wiring to IOB connector is not grounded.
Alt-122	Sensor Alert - Auto Demand Limit Input	Tested when the compressor is on all of the run status, if Demand Limit Type is set as 4-20mA type AND if auto demand limit input is less than 2mA	Automatic when the situation comes back to normal	Alert Relay is ON	20mA DEMAND LIMIT OPT is Enabled, Ice Build is not Active, and Auto Demand Limit Input on IOB is < 2 mA. Check 20 mA DEMAND LIMIT OPT and DEMAND LIMIT AT 20 mA in Service screen. Confirm that Auto Demand Limit Input is between 4 mA and 20 mA. Confirm that wiring to IOB connector is not grounded.
Alt-123	Sensor Alert - VFD Speed Out Of Range	If the ACTUAL VFD SPEED is less than the TARGET VFD SPEED - (TARGET VFD SPEED*10%) for 75 seconds when the chiller has been running for at least 3 minutes OR VFD_ACT sensor is out of range (VFD_IN < 0V Or VFD_IN > 10.5V)	Automatic when the situation comes back to normal	Alert Relay is ON	Check VFD speed feedback input in ISM
Alt-124	Sensor Alert - Humidity Sensor	Tested when the compressor is on all of the run status, If this input channel is enabled AND If the humidity transducer voltage outside range of 0.3V to 4.75V then the alert shall be tripped	Automatic when the situation comes back to normal	Alert Relay is ON	Check humidity sensor input in IOB
Alt-125	Sensor Alert - Refrigerant Leak Input	Tested when the compressor is on all of the run status, If this input channel is enabled AND If refrigerant leak input is less than 2mA AND Set Refrigerant Leak Option=Enable	Automatic when the situation comes back to normal	Alert Relay is ON	Check refrigerant leak optional input in IOB
Alt-126	Sensor Alert – Diffuser Pos Feedback	Tested when the compressor is on all of the run status, If this input channel is enabled AND diffuser option (diff_opt) is enabled If DIFF_ACT value is less than -1.0% OR DIFF_ACT is greater than 103.0%	Automatic when the situation comes back to normal	Alert Relay is ON	Check Diffuser Position feedback
Alt-127	Sensor Alert - VFD Current Input	If VFD load factor is more than 0.1 if the compressor has not been commanded to Turn ON AND Compressor is not running	Automatic when the situation comes back to normal	Alert Relay is ON	Check VFD current input
Alt-128	Sensor Alert - High Cond Water Pressure	Tested when the compressor is running, Water Pressure Option is enabled CDW_PD > COND_VAL for 2 minutes with cond_alm = disabled	Automatic when the situation comes back to normal	Alert Relay is ON	Check optional condenser water pressure sensor. Check condenser water flow

Table 16 — PIC6 Alert Codes* (cont)

ALERT CODE	DESCRIPTION OF ALERT TEXT	CRITERION FOR TRIP	ALERT RESET METHOD	ACTION TAKEN BY THE CONTROL	POSSIBLE CAUSE
Alt-129	Sensor Alert - Leaving Cond Water Temp	Tested when the compressor is on all of the run status and chiller is in cooling mode, If leaving condenser water temperature is outside range of -39.5 to 244.5°F	Automatic when the situation comes back to normal	Alert Relay is ON	LEAVING CONDENSER WATER temperature sensor reading is out of range. Check LEAVING CONDENSER WATER sensor resistance or voltage drop. Check for proper wiring to IOB. Check for grounded sensor leads.
Alt-130	Sensor Alert - Entering Cond Water Temp	Tested when the compressor is on all of the run status and chiller is in cooling mode, If entering condenser water temperature is outside range of -39.5 to 244.5°F	Automatic when the situation comes back to normal	Alert Relay is ON	Entering Condenser Water temperature sensor reading is out of range. Check Entering Condenser Water sensor resistance or voltage drop. Check for proper wiring to IOB. Check for grounded sensor leads.
Alt-131	Sensor Alert - Entering Cond Water Press	Tested when the compressor is on all of the run status, If hydraulic system option is enabled AND If Water Pressure Option is enabled, AND If the entering condenser water transducers voltage outside range of 0.3V to 4.75V	Automatic when the situation comes back to normal	Alert Relay is ON	Check Entering Condenser Water pressure sensor voltage drop. Check for proper wiring to IOB. Check for grounded sensor leads
Alt-132	Sensor Alert - Entering Chilled Water Press	Tested when the compressor is on all of the run status, If hydraulic system option is enabled AND If Water Pressure Option is enabled, AND If the entering chilled water transducers voltage outside range of 0.3V to 4.75V	Automatic when the situation comes back to normal	Alert Relay is ON	Check Entering Chilled Water pressure sensor voltage drop. Check for proper wiring to IOB. Check for grounded sensor leads.
Alt-133	Sensor Alert - Leaving Cond Water Press	Tested when the compressor is on all of the run status, If hydraulic system option is enabled AND If Water Pressure Option is enabled, AND If the leaving condenser water transducers voltage outside range of 0.3V to 4.75V	Automatic when the situation comes back to normal	Alert Relay is ON	Check Leaving Condenser Water pressure sensor voltage drop. Check for proper wiring to IOB. Check for grounded sensor leads.
Alt-134	Sensor Alert - Leaving Chilled Water Press	Tested when the compressor is on all of the run status, If hydraulic system option is enabled AND If Water Pressure Option is enabled, AND if the leaving chilled water transducers voltage outside range of 0.3V to 4.75V	Automatic when the situation comes back to normal	Alert Relay is ON	Check Leaving Chilled Water pressure sensor voltage drop. Check for proper wiring to IOB. Check for grounded sensor leads.
Alt-135	Sensor Alert - Guide Vane 1 Position	When the compressor has completed startup and is running, if either of the following occurs: a. GV1_ACT value is less than -1.0% b. GV1_ACT is greater than 103.0% c. The difference of GV1_ACT and GV1_TGT is more than 10% and guide vane is not in FORCE d. INPUTS_GV1_OHMS_enum and QCK_CAL_GV1_OHM_enum are not equal	Automatic when the situation comes back to normal	Alert Relay is ON	Check guide vane 1 position feedback
Alt-136	Configuration Error - Temp Reset	If reset type is temp reset AND If the configured remote temp (full reset) is greater than or equal to the configured remote temp (no reset)	Automatic when the situation comes back to normal	Alert Relay is ON	Check temp reset configurations
Alt-137	Configuration Error - Controlled Water Delta T Reset	If reset type is controlled water delta T reset AND If the configured controlled water delta T (full reset) is greater or equal to than the configured controlled water delta T (no reset)	Automatic when the situation comes back to normal	Alert Relay is ON	Check controlled water temp reset configurations
Alt-138	Configuration Error – Head Pressure	If Head Pres Delta P 0% is bigger than Head Pres Delta P 100%	Automatic when the situation comes back to normal	Alert Relay is ON	Check head pressure configurations
Alt-139	Sensor Alert - Guide Vane 2 Position	When the compressor has completed startup and is running, if either of the following occurs: a. GV2_ACT value is less than -1.0% b. GV2_ACT is greater than 103.0% c. The difference of GV2_ACT and GV2_TGT is more than 10% and guide vane is not in FORCE	Automatic when the situation comes back to normal	Alert Relay is ON	Check guide vane 2 position feedback
Alt-146	Process Alert - High Ref Filter Delta Pressure	If chiller type is 19DV and ref pump is ON, trigger it when ref pump lift (PUMPO_P-BRGI_P) > 9 PSI for continuously 300s	Automatic when the situation comes back to normal	Alert Relay is ON	Reset shall be automatic when the situation comes back to normal
Alt-147	Process Alert - Drainage System Failure	Tested only when PURGE OPTION is ON and chiller is not in quick test, trigger it if PGLE_HI is still ON when DRASVON is ON for continuously 1200 seconds	Automatic when the situation comes back to normal	Alert Relay is ON	Reset shall be automatic when the situation comes back to normal
Alt-148	Process Alert- Purge Daily Pumpout Limit Exceed	If purge time(PGP_TM) is larger than PGPUMPLM defined in 19DV Configuration	Automatic when the situation comes back to normal	Alert Relay is ON	Reset shall be automatic when the situation comes back to normal

Table 16 — PIC6 Alert Codes* (cont)

ALERT CODE	DESCRIPTION OF ALERT TEXT	CRITERION FOR TRIP	ALERT RESET METHOD	ACTION TAKEN BY THE CONTROL	POSSIBLE CAUSE
Alt-150	Process Alert - Low Discharge Superheat	If (DSH < DSH REQUIRED - 3.0) OR (DSH < 1.0F) for 60 seconds	Automatic when the situation comes back to normal	Alert Relay is ON	Check for excess refrigerant charge. Check actual SUPERHEAT in Temperature screen.
Alt-151	Process Alert - High Evaporator Approach	EVAP_APP > EVAP_AL AND (10 minutes after START COMPLETED (START_OK = TRUE) until compressor commanded to stop)	Automatic when the situation comes back to normal	Alert Relay is ON	Check EVAP APPROACH ALERT setting. Check Evaporator Water Flow. Check EVAP REFRIG LIQUID TEMP and LEAVING CHILLED WATER temperature sensor resistances and voltage drop. Check EVAP REFRIG LIQUID TEMP and LEAVING CHILLED WATER temperature sensor wiring to the IOB terminal block. Check for non-condensables and low refrigerant charge. Confirm that the optional refrigerant Liquid Line Isolation Valve is open. Check for float valve operation and for refrigerant stacking in the condenser. Check chilled water valves and strainers. Check for air in the evaporator water box or division plate bypass. Check for fouled tubes.
Alt-152	Process Alert - High Condenser Approach	COND_APP > COND_AL AND (10 minutes after START COMPLETED (START_OK = TRUE) until compressor commanded to stop)	Automatic when the situation comes back to normal	Alert Relay is ON	Check COND APPROACH ALERT setting. Check Condenser Water Flow. Check CONDENSER PRESSURE transducer and LEAVING CONDENSER WATER temperature sensor resistance or voltage drop. Check condenser shell temperature against condenser pressure measured with a refrigerant gage for evidence of non-condensable in refrigerant charge. Check for condenser water box division plate bypass. Check CONDENSER PRESSURE transducer and LEAVING CONDENSER WATER sensor wiring to the CCM. Check for air in the condenser water box. Confirm that the condenser tubes are not fouled.
Alt-153	Process Alert - High Noise Region	If chiller enters high noise region on the envelop control	Automatic when the situation comes back to normal	Alert Relay is ON	Check the envelope control configurations
Alt-154	Process Alert - Damper Valve Alert	If DAMPER VALVE POSITION = 3 (FAILURE) OR If the damper valve has been command to open for a continuous 5 minutes, and the DMP_FO is still not TRUE (Open/Close type actuator only) OR If the damper valve has been command to close for a continuous 5 minutes, and the DMP_FC is still not TRUE (Open/Close type actuator only)	Automatic when the situation comes back to normal	Alert Relay is ON	Check damper valve wiring and position feedback inputs
Alt-156	Process Alert - EC Valve Alert	If chiller type is 19XR6&7 Or 19DV AND { If HGBP_ACT =3 OR If the HGBP valve has been command to open for a continuous 5 minutes, and the HGBP_FO is still not TRUE OR If the HGBP valve has been command to close for a continuous 5 minutes, and the HGBP_FC is still not TRUE }	Automatic when situation comes back to normal	Alert Relay is ON	Check EC valve wiring and feedback inputs
Alt-157	Process Alert - High Condenser Pressure Chiller Off	When CONDENSER PRESSURE is greater than or equal to the CONDENSER PRESSURE OVERRIDE threshold AND the ENTERING CONDENSER WATER Temperature is less than 115°F	Automatic when CONDENSER PRESSURE is less than the (CONDENSER PRESSURE OVERRIDE threshold - 3.5 psi) AND the COND_SAT is less than or equal to the (ENTERING CONDENSER WATER Temperature + 3F)	Alert Relay is ON	Check condenser pressure sensor input And check condenser pressure override configurations
Alt-158	Process Alert - Prognostic Alert	If one or more prognostic items turn to abnormal	Automatic	Alert Relay is ON	Check Alarm Menu – Prognostic table for detailed information. Check LEN bus traffic with bus monitor
Alt-159	Process Alert – LEN Scan Warning	LEN scan warning (the traffic is a little bad) but is still working	Automatic	Alert Relay is ON	Check LEN bus traffic with bus monitor
Alt-161	Process Alert – Transducer Calibration	If one of the transducer differentials is more than the configurable threshold (refgc_th)	Automatic	Alert Relay is ON	Do the indicated transducer calibration

Table 16 — PIC6 Alert Codes* (cont)

ALERT CODE	DESCRIPTION OF ALERT TEXT	CRITERION FOR TRIP	ALERT RESET METHOD	ACTION TAKEN BY THE CONTROL	POSSIBLE CAUSE
Alt-162	Process Alert – Low Refrigerant Charge	Compressor is running but not in ramp loading status AND Condenser approach is greater than low refrigerant charge condenser approach threshold (rch_cath) AND Evaporator approach is 2 degF greater than design approach (ap_dgap)	Automatic	Alert Relay is ON	Recharge the refrigerant into chiller
Alt-163	Process Alert - Low Liquid Level in High Float VLV	When chiller type is 19DV, ? REF_PUMP is ON and chiller is in STARTUP status and COMP_RUN is FALSE, Then, trigger it if HF_LS is OFF for continuously 600 seconds.	Automatic	Alert Relay is ON	Check downstream float valve Alert relay is On, with compressor not running and refrigerant pump On; this alert will be active if liquid level is not satisfied after 10 minutes.
Alt-164	Process Alert – Displacement Switch	If the measured resistance < 800 Ohms, displacement switch alert	Manual	Alert Relay is ON	Check impeller displacement switch
Alt-166	Process Alert – Condenser Flushing	if the condenser water pump has not operated for 7 days	Automatic	Alert Relay is ON	Flush condenser
Alt-167	Process Alert – Customer Alert	If the Customer Alert Option is enabled, and the Customer Alert input contact is open.	Automatic	Alert Relay is ON	Check Customer Alert input contact
Alt 168	Process Alert - Low Temp/Potential Cond Freeze-up	If Condenser pressure sensor is in range AND Condenser Saturated Temp <= Condenser Freeze Point	Automatic when Condenser Saturated Temp > Condenser Freeze Point + 5°F (2.8°C)	Alert Relay turns on and condenser pumps are ON	Cold condenser saturated temperature in Ice duty applications.
Alt-169	Process Alert - High Evaporator Pressure	If evaporator pressure sensor is in the range AND { If the EVAPORATOR PRESSURE is greater than or equal to High Evap Press Override } { (if chiller type is 19DV, use 'Hi Evap Pre Override DV' instead)	Automatic	Alert Relay is ON	Check evaporator pressure sensor input and check evaporator pressure override configurations
Alt-170	Master Slave Alert - Master Slave Same Address	Master and slave units have the same network address.	Manual	Master slave work independent	Check master slave address configurations
Alt-171	Master Slave Alert - Conflict SW Version	Master and slave units have different application SW version.	Manual	Master slave work independent	Check master slave SW version number
Alt-172	Master Slave Alert - Conflict Cooling Heating Mode	Master and slave units have different cooling and heating mode selection	Manual	Master slave work independent	Check master slave cooling heating selection
Alt-173	Master Slave Alert - Incorrect Slave Control Type	The slave chiller is in local or remote or Local Schedule control	Manual	Master slave work independent	Check slave control type
Alt-174	Master Slave Alert - Slave Tripout	The slave chiller is down due to fault	Manual, automatic in Master side	Master slave work independent	Check slave chiller alarms
Alt-175	Master Slave Alert - Incorrect Master Control Type	The master chiller operating type is not Master	Manual	Master slave work independent	Check master control type
Alt-176	Master Slave Alert - No Communication Master / Slave	No communication with slave.	Automatic	Master slave work independent	Check communication between master and slave, wiring, etc.
Alt-179	Master Slave Alert - Master CCN Write Rejection	CCN command rejected by slave chiller	Manual	Master slave work independent	Check CCN communication, hardware and software
Alt-180	Master Slave Alert - Slave address not slave	Both chillers are configured to master If slave chiller address is configured in master chiller side but it is configured to disabled in slave chiller side	Manual	Alert Relay is ON	Check master slave configurations
Alt-181	Loss Communication with AHF GDCB 1	Check the communication with AHF every 1s, if no response, it will alert	Automatic	Alert Relay is ON	Check the communication configurations between the main control board and GDCB1 board, and the cables, etc.
Alt-182	Loss Communication with AHF GDCB 2	Check the communication with AHF every 1s, if no response, it will alert	Automatic	Alert Relay is ON	Check the communication configurations between the main control board and GDCB2 board, and the cables, etc.
Alt-183	Loss Communication with AHF GDCB 3	Check the communication with AHF every 1s, if no response, it will alert	Automatic	Alert Relay is ON	Check the communication configurations between the main control board and GDCB3 board, and the cables, etc.
Alt-184	Loss Communication with AHF GDCB 4	Check the communication with AHF every 1s, if no response, it will alert	Automatic	Alert Relay is ON	Check the communication configurations between the main control board and GDCB4 board, and the cables, etc.
Alt-185	AHF GDCB 1 Start Failure	Check the status of AHF every 1s, if there is device fault, it will alert	Automatic	Alert Relay is ON	Check AHF GDCB board 1 and the related configurations
Alt-186	AHF GDCB 2 Start Failure	Check the status of AHF every 1s, if there is device fault, it will alert	Automatic	Alert Relay is ON	Check AHF GDCB board 2 and the related configurations
Alt-187	AHF GDCB 3 Start Failure	Check the status of AHF every 1s, if there is device fault, it will alert	Automatic	Alert Relay is ON	Check AHF GDCB board 3 and the related configurations
Alt-188	AHF GDCB 4 Start Failure	Check the status of AHF every 1s, if there is device fault, it will alert	Automatic	Alert Relay is ON	Check AHF GDCB board 4 and the related configurations

Table 16 — PIC6 Alert Codes* (cont)

ALERT CODE	DESCRIPTION OF ALERT TEXT	CRITERION FOR TRIP	ALERT RESET METHOD	ACTION TAKEN BY THE CONTROL	POSSIBLE CAUSE
Alt-190	AHF Fault	Receive a fault state from AHF	Automatic	Alert Relay is ON	Reset the AHF - if fault persists, please determine the fault state and contact Service
Alt -191	Loss Communication with AHF	No response from AHF for 10 consecutive seconds	Automatic	Alert Relay is ON	Check communication line

* This Alert table is not specific to 19DV chiller. References to oil are not associated with 19DV product.

Table 17 — PIC6 Alarm Codes*

ALARM CODE	DESCRIPTION OF ALARM TEXT	CRITERION FOR TRIP	ALARM RESET METHOD	ACTION TAKEN BY THE CONTROL	POSSIBLE CAUSE
Alm-200	Sensor Fault - Leaving Chilled Water	Tested when the compressor is on whatever the run status and the communication between Main board and IOBs is ok, If leaving chilled water temperature is outside range of -39.5 to 244.5°F.	Automatic when the temperature reading is inside the range of -39.5 to 244.5°F	Unit shuts down. Alarm relay turns on.	Check sensor resistance. Check for proper wiring between LEAVING CHILLED WATER Temperature Sensor and IOB connector. Check for disconnected, grounded, or shorted wiring.
Alm-201	Sensor Fault - Entering Chilled Water	Tested when the compressor is on whatever the run status and the communication between Main board and IOBs is ok, If entering chilled water temperature is outside range of -39.5 to 244.5°F.	Automatic when the temperature reading is inside the range of -39.5 to 244.5°F.	Unit shuts down. Alarm relay turns on.	Check sensor resistance. Check for proper wiring between Entering Chilled Water Sensor and IOB connector. Check for disconnected, grounded, or shorted wiring.
Alm-202	Sensor Fault - Leaving Cond Water Temp	Tested when the compressor is on whatever the run status and the communication between Main board and IOBs is ok, chiller is in heating mode, and entering water temp control is disabled, If leaving condenser water temperature is outside range of -39.5 to 244.5°F.	Automatic when the temperature reading is inside the range of -39.5 to 244.5°F.	Unit shuts down. Alarm relay turns on.	Check sensor resistance. Check for proper wiring between Leaving Cond Water Temp Sensor and IOB connector. Check for disconnected, grounded, or shorted wiring.
Alm-203	Sensor Fault - Entering Cond Water Temp	Tested when the compressor is on whatever the run status and the communication between Main board and IOBs is ok, chiller is in heating mode, and entering water temp control is enabled, If entering condenser water temperature is outside range of -39.5 to 244.5°F.	Automatic when the temperature reading is inside the range of -39.5 to 244.5°F.	Unit shuts down. Alarm relay turns on.	Check sensor resistance. Check for proper wiring between Entering Cond Water Temp Sensor and IOB connector. Check for disconnected, grounded, or shorted wiring.
Alm-204	Sensor Fault - Comp Discharge Temp	Tested when the compressor is on whatever the run status and the communication between Main board and IOBs is ok, If compressor discharge temperature is outside range of -39.5 to 244.5°F.	Automatic when the temperature reading is inside the range of -39.5 to 244.5°F.	Unit shuts down. Alarm relay turns on.	Check sensor resistance. Check for proper wiring between Comp Discharge Temp Sensor and connector. Check for disconnected, grounded, or shorted wiring.
Alm-207	Sensor Fault - Evap Refrig Liquid Temp	Tested when the compressor is on whatever the run status and the communication between Main board and IOBs is ok, If evap refrigerant liquid temperature is outside range of -39.5 to 244.5°F.	Automatic when the temperature reading is inside the range of -39.5 to 244.5°F.	Unit shuts down. Alarm relay turns on.	Check sensor resistance. Check for proper wiring between Evap Refrig Liquid Temp Sensor and IOB connector. Check for disconnected, grounded, or shorted wiring.
Alm-208	Sensor Fault - Low Speed Motor End Bearing Temp	Tested when the compressor is on whatever the run status and the communication between Main board and IOBs is ok, If compressor bearing temperature 1 is outside range of -39.5 to 244.5°F.	Automatic when the temperature reading is inside the range of -39.5 to 244.5°F.	Unit shuts down. Alarm relay turns on.	Check sensor resistance. Check for proper wiring between Low Speed Motor End Bearing Temp Sensor and IOB connector. Check for disconnected, grounded, or shorted wiring.
Alm-209	Sensor Fault - Low Speed Comp End Bearing Temp	Tested when the compressor is on whatever the run status and the communication between Main board and IOBs is ok, If compressor bearing temperature 2 is outside range of -39.5 to 244.5°F.	Automatic when the temperature reading is inside the range of -39.5 to 244.5°F.	Unit shuts down. Alarm relay turns on.	Check sensor resistance. Check for proper wiring between Low Speed Comp End Bearing Temp 2 Sensor and IOB connector. Check for disconnected, grounded, or shorted wiring.
Alm-210	Sensor Fault - High Speed Motor End Bearing Temp	Tested when the compressor is on whatever the run status and the communication between Main board and IOBs is ok, If compressor bearing temperature 3 is outside range of -39.5 to 244.5°F.	Automatic when the temperature reading is inside the range of -39.5 to 244.5°F.	Unit shuts down. Alarm relay turns on.	Check sensor resistance. Check for proper wiring between High Speed Motor End Bearing Temp Sensor and IOB connector. Check for disconnected, grounded, or shorted wiring.
Alm-211	Sensor Fault - High Speed Comp End Bearing Temp	Tested when the compressor is on whatever the run status and the communication between Main board and IOBs is ok, If compressor bearing temperature 4 is outside range of -39.5 to 244.5°F.	Automatic when the temperature reading is inside the range of -39.5 to 244.5°F.	Unit shuts down. Alarm relay turns on.	Check sensor resistance. Check for proper wiring High Speed Comp End Bearing Temp Sensor and IOB connector. Check for disconnected, grounded, or shorted wiring.
Alm-212	Sensor Fault - Comp Motor Winding 1 Temp	Tested when the compressor is on whatever the run status and the communication between Main board and IOBs is ok, If compressor motor temperature 1 is outside range of -39.5 to 244.5°F.	Automatic when the temperature reading is inside the range of -39.5 to 244.5°F.	Unit shuts down. Alarm relay turns on.	Check sensor resistance. Check for proper wiring between Compressor Motor Temp 1 Sensor and IOB connector. Check for disconnected, grounded, or shorted wiring.
Alm-213	Sensor Fault - Comp Motor Winding 2Temp	Tested when the compressor is on whatever the run status and the communication between Main board and IOBs is ok, If compressor motor temperature 2 is outside range of -39.5 to 244.5°F.	Automatic when the temperature reading is inside the range of -39.5 to 244.5°F.	Unit shuts down. Alarm relay turns on.	Check sensor resistance. Check for proper wiring between Compressor Motor Temp 2 Sensor and IOB connector. Check for disconnected, grounded, or shorted wiring.
Alm-214	Sensor Fault - Comp Motor Winding 3 Temp	Tested when the compressor is on whatever the run status and the communication between Main board and IOBs is ok, If compressor motor temperature 3 is outside range of -39.5 to 244.5°F.	Automatic when the temperature reading is inside the range of -39.5 to 244.5°F.	Unit shuts down. Alarm relay turns on.	Check sensor resistance. Check for proper wiring between Compressor Motor Temp 3 Sensor and IOB connector. Check for disconnected, grounded, or shorted wiring.
Alm-215	Sensor Fault - Condenser Pressure	Tested when the compressor is whatever the run status and the communication between Main board and IOBs is ok. If chiller type is 19DV then if the condenser transducer voltage outside range of 0.3V to 4.67V else if the condenser transducer voltage outside range of 0.3V to 4.75V.	Automatic when the voltage reading is inside the range of 0.3V to 4.75V.	Unit shuts down. Alarm relay turns on.	Check condenser pressure transducer wiring. Confirm that 5 V reference signal is available between IOB connector. Check for disconnected, grounded, or shorted wiring. Check for condensation in transducer connector.

Table 17 — PIC6 Alarm Codes* (cont)

ALARM CODE	DESCRIPTION OF ALARM TEXT	CRITERION FOR TRIP	ALARM RESET METHOD	ACTION TAKEN BY THE CONTROL	POSSIBLE CAUSE
Alm-216	Sensor Fault - Evaporator Pressure	Tested when the compressor is whatever the run status and the communication between Main board and IOBs is ok. If chiller type is 19DV then if the evaporator transducer voltage outside range of 0.3V to 4.67V else if the evaporator transducer voltage outside range of 0.3V to 4.75V.	Automatic when the voltage reading is inside the range of 0.3V to 4.75V.	Unit shuts down. Alarm relay turns on.	Check Evaporator pressure transducer wiring. Confirm that 5 V reference signal is available between IOB connector. Check for disconnected, grounded, or shorted wiring. Check for condensation in transducer connector.
Alm-217	Sensor Fault - Economizer Pressure	If chiller type is 19XR6&7, if the economizer transducer voltage is outside range of 0.3V to 4.75V.	Automatic when the voltage reading is inside the range of 0.3V to 4.75V.	Unit shuts down. Alarm relay turns on.	Check Economizer pressure transducer wiring. Confirm that 5 V reference signal is available between IOB connector. Check for disconnected, grounded, or shorted wiring. Check for condensation in transducer connector.
Alm-218	Sensor Fault - Diffuser Pressure	Tested when the compressor is whatever the run status and the communication between Main board and IOBs is ok, and if diffuser option is enabled, if the diffuser transducer voltage outside range of 0.3V to 4.75V.	Automatic when the voltage reading is inside the range of 0.3V to 4.75V.	Unit shuts down. Alarm relay turns on.	Check Diffuser pressure transducer wiring. Confirm that 5 V reference signal is available between IOB connector. Check for disconnected, grounded, or shorted wiring. Check for condensation in transducer connector.
Alm-223	Sensor Fault – Purge Comp Suction Temp	Tested when the compressor is on whatever run status and the communication between Main board and SIOB is ok, If Purge Comp Inlet temperature is outside range of -39.5 to 244.5°F.	Automatic when the temperature reading is inside the range of -39.5 to 244.5°F.	Unit shuts down. Alarm relay turns on.	Check sensor resistance. Check for proper wiring between Purge Comp Suction Temp Sensor and IOB connector. Check for disconnected, grounded, or shorted wiring.
Alm-225	Sensor Fault – Pump Inlet Pressure	If chiller type is 19DV, Tested when the compressor is whatever the run status and the communication between Main board and IOBs is ok, if the Pump Inlet Transducer voltage outside range of 0.3V to 4.67V.	Automatic when the voltage reading is inside the range of 0.3V to 4.75V.	Unit shuts down. Alarm relay turns on.	Check Pump Inlet pressure transducer wiring. Confirm that 5 V reference signal is available between IOB connectors. Check for disconnected, grounded, or shorted wiring. Check for condensation in transducer connector.
Alm-226	Sensor Fault – Bearing Inlet Pressure	If chiller type is 19DV, Tested when the compressor is whatever the run status and the communication between Main board and IOBs is ok, if the Bearing Inlet Transducer voltage outside range of 0.3V to 4.67V.	Automatic when the voltage reading is inside the range of 0.3V to 4.75V.	Unit shuts down. Alarm relay turns on.	Check Bearing Inlet pressure transducer wiring. Confirm that 5 V reference signal is available between IOB connectors. Check for disconnected, grounded, or shorted wiring. Check for condensation in transducer connector.
Alm-227	Sensor Fault – Bearing Outlet Pressure	If chiller type is 19DV, Tested when the compressor is whatever the run status and the communication between Main board and IOBs is ok, if the Bearing Outlet Transducer voltage outside range of 0.3V to 4.67V.	Automatic when the voltage reading is inside the range of 0.3V to 4.75V.	Unit shuts down. Alarm relay turns on.	Check Bearing Outlet pressure transducer wiring. Confirm that 5 V reference signal is available between IOB connectors. Check for disconnected, grounded, or shorted wiring. Check for condensation in transducer connector.
Alm-228	Sensor Fault – Common CHWS Temp	Tested when the compressor is on whatever the run status and the communication between Main board and IOBs is ok, If CHWS temperature is outside range of -39.5 to 244.5°F.	Automatic when the temperature reading is inside the range of -39.5 to 244.5°F.	Unit shuts down. Alarm relay turns on.	Check sensor resistance. Check for proper wiring between Common CHWS Temp Sensor and IOB connector. Check for disconnected, grounded, or shorted wiring.
Alm-229	Sensor Fault – Common CHWR Temp	Tested when the compressor is on whatever the run status and the communication between Main board and IOBs is ok, If CHWR temperature is outside range of -39.5 to 244.5°F.	Automatic when the temperature reading is inside the range of -39.5 to 244.5°F.	Unit shuts down. Alarm relay turns on.	Check sensor resistance. Check for proper wiring between Common CHWR Temp and IOB connector. Check for disconnected, grounded, or shorted wiring.
Alm-230	Prestart Failure - High Bearing Temperature	Tested only on prestart condition, if all of the bearing temperature sensors are in the range AND if one of the COMP BEARING TEMP >= COMP BEARING ALERT DV - 10F for 19DV.	Manual	Unit shuts down. Compressor is not allowed to start. Alarm relay turns on.	Check Comp Bearing Temp in Temperature screen. Check Comp Bearing Temp Alert setting.
Alm-231	Prestart Failure - High Motor Temperature	Tested only on prestart condition, if all of the motor temperature sensors are in the range AND if one of the COMP MOTOR WINDING TEMP >= MOTOR TEMP OVERRIDE - 10F.	Manual	Unit shuts down. Alarm relay turns on.	Check Comp Motor Wind Temp in Temperature screen. Check motor temperature sensor for wiring and accuracy to IOB connector. Check motor cooling line and isolation valves for proper operation, or restrictions, check refrigerant filter/drier. Check for excessive starts within a short time span. Check Comp Motor Temp Override setting.
Alm-232	Prestart Failure - High Discharge Temp	Tested only on prestart condition, if the compressor discharge temperature sensor are in the range AND if COMP DISCHARGE TEMP >= COMP DISCHARGE ALERT- 10F.	Manual	Unit shuts down. Alarm relay turns on.	Check Comp Discharge Temp in screen Allow compressor discharge temperature sensor to cool. Check compressor discharge temperature sensor wiring and accuracy to IOB connector. Check for excessive starts. Check COMP DISCHARGE ALERT setting.

Table 17 — PIC6 Alarm Codes* (cont)

ALARM CODE	DESCRIPTION OF ALARM TEXT	CRITERION FOR TRIP	ALARM RESET METHOD	ACTION TAKEN BY THE CONTROL	POSSIBLE CAUSE
Alm-233	Prestart Failure - Low Refrigerant Temp	Tested only on prestart condition, if Evaporator pressure sensor and temperature sensor are in the range AND { if EVAP SAT < refrig trip + REFRIG OVERRIDE DELTA T OR EVAP REFRIG LIQUID TEMP < refrig trip + REFRIG OVERRIDE DELTA T } refrig trip = 33F for water and configurable for brine.	Manual	Unit shuts down. Alarm relay turns on.	Check Evaporator Pressure, Evap Sat Refrig Temp, and Evap Refrig Liquid Temp. Check REFRIG OVERRIDE DELTA T and EVAP REFRIG TRIPPOINT in configuration screen. Check refrigerant charge. Check for low chilled water supply temperatures. Check Evaporator Pressure transducer and Evaporator Refrigerant Liquid Temperature sensor wiring and accuracy.
Alm-234	Prestart Failure - Low Line Voltage	Tested only on prestart condition, if ACTUAL LINE VOLTAGE <= UNDERVOLTAGE THRESHOLD Note: When VFD OPTION is set to Rockwell or Eaton, this prestart check will be ignored.)	Manual	Unit shuts down. Alarm relay turns on.	Check ACTUAL LINE VOLTAGE. Check UNDERVOLTAGE THRESHOLD in ISM_CONF screen. Check voltage supply. Check wiring to ISM J3-L1, J3-L2, and J3-L3. Check voltage transformers and switch gear. Consult power utility if voltage is low.
Alm-235	Prestart Failure - High Line Voltage	Tested only on prestart condition, if ACTUAL LINE VOLTAGE >= OVERVOLTAGE THRESHOLD Note: When VFD OPTION is set to Rockwell or Eaton, this prestart check will be ignored.)	Manual	Unit shuts down. Alarm relay turns on.	Check ACTUAL LINE VOLTAGE. Check OVERVOLTAGE THRESHOLD in ISM_CONF screen. Check voltage supply. Check voltage transformers and switch gear. Consult power utility if voltage is high.
Alm-236	Guide Vane 1 Calibration Not Completed	Tested on control test mode or prestart check, if Guide vane 1 calibration is failed For over-driven protection. If IGV1 is not calibrated, chiller is OFF, and not in Control Test Mode.IGV1 shall be commanded to close for 5 minutes. When 5 minutes expired, report this alarm.	Manual	Unit shuts down. Alarm relay turns on.	Guide Vane 1 Calibration in Quick Calibration screen. Check guide vane actuator feedback potentiometer and wiring to IOB connector.
Alm-237	Prestart Failure – No Power Supply	If WATER VERIFICATION TIME has passed after REQUEST TO START had been sent, there is still no PERMISSION TO START received.	Manual	Unit shuts down. Alarm relay turns on.	Check the Power Request Output and the Power Feedback input status.
Alm-238	Guide Vane 2 Calibration Not Completed	Tested on control test mode or prestart check, if Guide vane 2 calibration is failed For over-driven protection. If IGV2 is not calibrated, chiller is OFF, and not in Control Test Mode.IGV2 shall be commanded to close for 5 minutes. When 5 minutes expired, report this alarm.	Manual	Unit shuts down. Alarm relay turns on.	Guide Vane 2 Calibration in Quick Calibration screen. Check guide vane actuator feedback potentiometer and wiring to IOB connector.
Alm-239	Envelope Control Valve Calibration Not Completed	Tested on control test mode or prestart check, if HGBP calibration is failed.	Manual	Unit shuts down. Alarm relay turns on.	Envelope control valve Calibration in Quick Calibration screen. Check EC valve feedback potentiometer and wiring to IOB connector.
Alm-240	Damper Valve Calibration Not Completed	Tested on control test mode or prestart check, if Damper calibration is failed.	Manual	Unit shuts down. Alarm relay turns on.	Tested on control test mode or prestart check, if Damper calibration is failed.
Alm-251	Protective Limit - Low Chilled Water Flow	CHW_FLOW = FALSE and 5s after CHWP =ON and water flow verify time passed	Manual	Unit shuts down. Alarm relay turns on.	Perform Chilled Water pump test in Quick Test screen. Check Evap Refrig Liquid Temp and Leaving CHILLED WATER temperature sensor accuracy and wiring to IOB. Check chilled water valves, pumps, and strainers. Check EVAP REFRIG TRIPPOINT, EVAP APPROACH ALERT, EVAP FLOW DELTA P CUTOUT, and WATER FLOW VERIFY TIME settings. Check load resistors, optional water flow switches or water flow delta P transducer calibration and wiring to IOB. Check for 5.0 V reference voltage between IOB connectors.
Alm-252	Protective Limit - Low Condenser Water Flow	CDW_FLOW = FALSE and 5s after CDWP =ON and water flow verify time passed	Manual	Unit shuts down. Alarm relay turns on.	Perform Condenser Water pump test in Quick Test screen. Check CONDENSER PRESSURE transducer and LEAVING CONDENSER WATER temperature sensor accuracy and wiring. Check condenser water valves and strainers. Check COND PRESS OVERRIDE, COND APPROACH ALERT, COND FLOW DELTA P CUTOUT, and WATER FLOW VERIFY TIME settings. Check load resistors, optional water flow switches or water flow delta P transducer calibration and wiring to IOB. Check for 5.0 V reference voltage between IOB connectors.

Table 17 — PIC6 Alarm Codes* (cont)

ALARM CODE	DESCRIPTION OF ALARM TEXT	CRITERION FOR TRIP	ALARM RESET METHOD	ACTION TAKEN BY THE CONTROL	POSSIBLE CAUSE
Alm-253	Protective Limit - High Discharge Temp	If compressor discharge temperature sensor is in the range AND Compressor discharge temp > 167F (For legacy chiller, this value is 220F)	Manual	Unit shuts down. Alarm relay turns on.	Check for closed compressor discharge isolation valve. Check if chiller was operating in surge conditions. Check COMP DISCHARGE TEMP sensor resistance or voltage drop. Check for proper wiring to IOB connectors. Check for proper condenser flow and temperature. Check for fouled tubes, plugged water strainers, or non-condensable in the condenser. Check for COMP DISCHARGE TEMP > 220 deg F. Check for proper inlet guide vane and optional diffuser actuator operation.
Alm-255	Protective Limit - High Motor Temperature	If motor temperature sensor is in the range AND If any of the Compressor motor winding temp >220F	Manual	Unit shuts down. Alarm relay turns on.	Check COMP MOTOR WINDING TEMP accuracy and wiring to IOB.
Alm-256	Protective Limit - High Bearing Temperature	For 19DV chiller, if all of the bearing temperature sensors are in the range AND { If any of the other Compressor bearing temp > tb_trip3 }	Manual	Unit shuts down. Alarm relay turns on.	Check COMP BEARING TEMP sensors accuracy and wiring to IOB. . This fault can result from excessive operation at low load with low water flow to the evaporator or condenser.
Alm-257	Protective Limit - High Condenser Pressure	If condenser pressure sensor is in the range AND { COND_P > COND Pressure Cutout (it is Cond Press Cutout Low Press for low pressure condenser configuration and Cond Press Cutout High Press for high pressrue condenser configuration) }	Manual	Unit shuts down. Alarm relay turns on.	Check CONDENSER PRESSURE. Check for high Condenser Water temperatures, low water flow, fouled tubes. Check for division plate/gasket bypass or plugged condenser water strainers. Check for noncondensables in condenser. Check CONDENSER PRESSURE transducer wiring and accuracy to IOB. . Configure COND PRESS OVERRIDE in configuration screen. This Alarm is not caused by the High Condenser Pressure Switch.
Alm-258	Protective Limit - Spare Safety Device	If the spare safety input in IOB3 goes to CLOSED	Manual	Unit shuts down. Alarm relay turns on.	Spare safety input has been closed
Alm-259	Protective Limit - Excessive Compressor Surge	If SURGE COUNTS exceed 4 within a SURGE TIME PERIOD on the condition that guide vane and VFD and HGBP cannot be acted for surge protection OR If SURGE PROTECTION COUNTS exceed 20 within a SURGE TIME PERIOD. If vfd_opt is enabled, then VFD speed should be maximum (cannot moveable) before trip this alarm.	Manual	Unit shuts down. Alarm relay turns on.	Five SURGE PROTECTION COUNTS occurred within SURGE TIME PERIOD. VFD Only: Surge prevention alarm declared when ACTUAL VFD SPEED is at least 90%. Check for high condenser water temperatures, low water flow, fouled tubes. Check CONDENSER APPROACH. Check condenser water strainers. Check for division plate/gasket bypass. Check for noncondensables in condenser. Check surge prevention parameters in OPTIONS screen. Compare cooling tower control settings and performance against design/selection temperatures across the entire operating range of the chiller. Check EVAPORATOR APPROACH and chilled water flow.
Alm-260	Protective Limit - Compressor Start Relay Start failure	if START_OK is still not TRUE after 2 minute compressor start relay energized	Manual	Unit shuts down. Alarm relay turns on.	Check motor starter 1M contactor wiring Check ISM current sensors
Alm-261	Protective Limit - Evaporator Frozen	If evaporator refrigerant temperature and evaporator pressure sensor is in the range AND {If the less of evaporator refrigerant temperature and the saturated temperature is less than evaporator refrigerant trip point plus 1 degree F} This alarm is also effective on pumpdown/lockout"	Manual	Unit shuts down. Alarm relay turns on.	Check CALC EVAP SAT TEMP, EVAP REFRIG LIQUID TEMP, and EVAP REFRIG TRIPPOINT. Check for proper refrigerant charge. Check float valve operation. Confirm that optional refrigerant liquid line isolation valve is open. Check for proper Chilled Water flow and temperature. Confirm that condenser water enters bottom row of condenser tubes first, reversed condenser water flow may cause refrigerant to stack in the condenser. Check EVAPORATOR PRESSURE transducer and EVAP REFRIG LIQUID TEMP sensor. Check for evaporator water box division plate gasket bypass. Check for fouled tubes.
Alm-263	Protective Limit - Invalid Diffuser Config	Diffuser configuration is invalid	Automatic	Unit shuts down. Alarm relay turns on.	Check SRD configurations

Table 17 — PIC6 Alarm Codes* (cont)

ALARM CODE	DESCRIPTION OF ALARM TEXT	CRITERION FOR TRIP	ALARM RESET METHOD	ACTION TAKEN BY THE CONTROL	POSSIBLE CAUSE
Alm-264	Protective Limit - Diffuser Position Fault	Diffuser alarm is set to TRUE	Manual	Unit shuts down. Alarm relay turns on.	Confirm that Diffuser Option in SRD Configuration screen has not been Enabled if compressor does not have a split ring diffuser. May indicate rotating stall condition. Check rotating stall transducer wiring accuracy and sealing. Check diffuser schedule and guide vane schedule in SRD Configuration screen. Check for proper operation of diffuser and inlet guide vane actuators including inlet guide vane calibration. Check diffuser actuator coupling for rotational slip. Check for electrical noise in IOB Diffuser Pressure wiring. Do not continue to operate compressor except for diagnostic purposes.
Alm-265	Protective Limit - Refrigerant Leak	If the REFRIGERANT LEAK OPTION is ENABLED and the REFRIGERANT LEAK SENSOR > REFRIG LEAK ALARM mA (leak_ma)	Manual	Unit shuts down. Alarm relay turns on.	REFRIGERANT LEAK OPTION is Enabled and the REFRIGERANT LEAK SENSOR output exceeded REFRIGERANT LEAK ALARM mA. Check for refrigerant leaks. Check leak detector for proper operation. Check REFRIGERANT LEAK ALARM mA setting in the OPTIONS screen. Check 4-20 mA or 1-5 V output from refrigerant leak sensor to IOB J15-5 Confirm that IOB SW2 dip switch 1 is in the correct position.
Alm-266	Protective Limit - IOB Low Voltage	If one of the low voltage flags are set to TRUE (low_volX = true)	Automatic	Unit shuts down. Alarm relay turns on.	Check IOB 24VAC power supply and the transformer output voltage
Alm-267	Protective Limit - Guide Vane 1 Fault	If compressor type is dual stage compressor, During Startup, prior to energizing the refrigerant pump, the guide vanes shall be commanded to Guide Vane Closure at Startup (gv1stpos). If the ACTUAL GUIDE VANE POS is out of range of (gv1stpos+-1.0%) after 4 minutes of action For over-driven protection, If IGV1 is calibrated, and chiller is OFF. When 5 minutes expired, If IGV1 feedback is still > 2%, report this alarm.	Manual	Unit shuts down. Alarm relay turns on.	Alarm before start indicates guide vane opening has not closed to less than 4%. Alarm while running indicates guide vane position is < -1% or > 103%. Enter Quick Calibration and conduct Guide Vane Calibration. Check wiring between the guide vane feedback potentiometer and IOB terminals. Check the ohm guide vane position feedback potentiometer or 4-20mA current
Alm-269	Protective Limit - Envelope Control Valve Fault	If HGBP option is enabled AND During Startup, prior to energizing the refrigerant pump, the hot gas bypass valve shall be fully closed. If hot gas bypass valve is not fully closed after 4 minutes of closing	Manual	Unit shuts down. Alarm relay turns on.	Check Envelope Control valve wirings
Alm-270	Protective Limit - High Cond Water Flow	If condenser water sensor option is enabled and condenser water pressure sensors are in the range AND { CDW_PD > COND_VAL for 2 minutes when compressor is running, with cond_alm = enabled }	Manual	Unit shuts down. Alarm relay turns on.	Check condenser water pressure sensor and wirings
Alm-271	Protective Limit - Emergency Stop	When EMSTOP from NETWORK is changed to TRUE by network command OR Remote emergency stop contact is changed to Closed	Manual	Unit shuts down. Alarm relay turns on.	Check EMSTOP command form network and the remote stop dry contact from IOB
Alm-272	Protective Limit - ISM Config Conflict	If the configurations in configuration table are different from the configurations in maintenance table for ISM configurations, and the communication timeout parameter is not in the comparison list	Manual	Unit shuts down. Alarm relay turns on.	Configuration data in controller and ISM are mismatch. In maintains menu, choose "maintains ISM config" ->"Delete ISM config" NO – upload ISM configuration data to HMI YES–download ISM configuration to ISM
Alm-273	Protective Limit - Swift Restarts Limit Exceeded	if chiller swift restart counter > 4 in one hour	Manual	Unit shuts down. Alarm relay turns on.	Check the reason why swift restart happens so frequently.
Alm-274	Protective Limit –Chiller Lockout	If the chiller lockout input in IOB1 goes to CLOSED	Manual	Unit shuts down. Alarm relay turns on.	Check chiller lockout input in IOB
Alm-275	Protective Limit – Fire Alarm	If the fire alarm input in IOB1 goes to CLOSED	Manual	Unit shuts down. Alarm relay turns on.	Check fire alarm input in IOB
Alm-276	Protective Limit –Stop Override	If stop override (stp_over) is enabled	Manual	Unit shuts down. Alarm relay turns on.	Check stop override point status in GENUNIT table
Alm-277	Protective Limit - UI Freeze Reboot	UI Module freeze because of unknown cause	Power on reset PIC6 controller	Unit shuts down. Alarm relay turns on.	Power on reset Carrier SmartView™ controller
Alm-278	Protective Limit - VFD Config Conflict	If the configurations in configuration table are different from the configurations in maintenance table for Carrier LV32 VFD (DCIB board) configurations	Manual	Unit shuts down. Alarm relay turns on.	Reset shall be automatic when communication comes back to normal
Alm-279	Protective Limit - VFD Config Failure	The VFD configuration value on PIC6 exceed the limitation of VFD	Manual	Unit shuts down. Alarm relay turns on.	Check VFD Configurations and save it again
Alm-280	Protective Limit – High VFD Speed	If the ACTUAL VFD SPEED is greater than the TARGET VFD SPEED +10% for 75 seconds when the chiller has been running for at least 3 minutes.	Manual	Unit shuts down. Alarm relay turns on.	Check VFD actual speed

Table 17 — PIC6 Alarm Codes* (cont)

ALARM CODE	DESCRIPTION OF ALARM TEXT	CRITERION FOR TRIP	ALARM RESET METHOD	ACTION TAKEN BY THE CONTROL	POSSIBLE CAUSE
Alm-282	Protective Limit - Displacement Switch	If the displacement switch channel is Enabled and this switch goes to OPEN	Manual	Unit shuts down. Alarm relay turns on.	Check impeller displacement switch for NGC chiller
Alm-283	Protective Limit - High Pressure Switch	If the high pressure switch goes to OPEN	Manual	Unit shuts down. Alarm relay turns on.	Check high pressure switch for NGC chiller
Alm-284	Protective Limit - Power Feedback Loss	If the chiller is not in OFF or STARTUP status, and POWER REQUEST is TRUE, but POWER FEEDBACK is lost	Manual	Unit shuts down. Alarm relay turns on.	Check Power Feedback Input
Alm-285	Protective Limit - Low Bearing Delta Pres Difference	If Bearing Input Pressure and Bearing Output Pressure are in the range This alarm should be triggered under following situations: <ul style="list-style-type: none"> • When chiller is at the stage of Pre-Lubrication, BEARING DELTA P is less than 8 psi for continuously 8 seconds. • If compressor is ON and runs within 5 mins, BEARING DELTA P is less than 8psi for continuously 30 seconds. • If compressor is ON and runs more than 5 mins, BEARING DELTA P is less than 10psi for continuously 30 seconds. • when refrigerant pump is OFF and startup in progress BEARING DELTA P is larger than or equal to 5 psi • In startup process, BEARING DELTA P failed to reach 12 psi during OIL/REF PRESS VERIFY TIMETIME (SERVICE1_oilpvr_t_enumseconds). 	Manual	Unit shuts down. Alarm relay turns on.	Alarm active if Bearing Delta P is less than 8 psi for 8s during Pre-lube/ Startup OR When compressor is running the Bearing Delta P is less than 10 psig for 30s
Alm-292	Protective Limit - Guide Vane 2 Fault	For over-driven protection, If IGV2 is calibrated, and chiller is OFF. When 5 minutes expired, if IGV2 feedback is still > 2%, report this alarm.	Manual	Unit shuts down. Alarm relay turns on.	Alarm before start indicates guide vane opening has not closed to less than 4%. Alarm while running indicates guide vane position is < -1% or > 103%. Enter Quick Calibration and conduct Guide Vane Calibration. Check wiring between the guide vane feedback potentiometer and IOB terminals. Check the 4-20mA current
Alm-296	Protective Limit - High Evaporator Pressure	If evaporator pressure sensor is in the range AND { EVAP_P > High Evap Press Cutout } (if chiller type is 19DV, use 'Hi Evap Pre Cutout DV' instead)	Manual	Unit shuts down. Alarm relay turns on.	Check evaporator pressure sensor input And check evaporator pressure cutout configurations
Alm-301	Loss Communication With IOB1	Communication between main controller with IOB1 lost for 10 consecutive seconds OR IOB 1 (address 117) is not searched	Automatic when communication comes back to normal	Unit shuts down. Alarm relay turns on.	Bus installation fault or defective slave board
Alm-302	Loss Communication With IOB2	Communication between main controller with IOB2 lost for 10 consecutive seconds OR IOB 2 (address 118) is not searched	Automatic when communication comes back to normal	Unit shuts down. Alarm relay turns on.	Bus installation fault or defective slave board
Alm-303	Loss Communication With IOB3	Communication between main controller with IOB3 lost for 10 consecutive seconds OR IOB 3 (address 119) is not searched	Automatic when communication comes back to normal	Unit shuts down. Alarm relay turns on.	Bus installation fault or defective slave board
Alm-304	Loss Communication With IOB4	If IOB 4 is configured AND {Communication between main controller with IOB4 lost for 10 consecutive seconds OR IOB 4 (address 120) is not searched }	Automatic when communication comes back to normal	Unit shuts down. Alarm relay turns on.	Bus installation fault or defective slave board
Alm-305	Loss Communication With IOB5	If IOB 5 is configured AND {Communication between main controller with IOB5 lost for 10 consecutive seconds OR IOB 5 (address 121) is not searched }	Automatic when communication comes back to normal	Unit shuts down. Alarm relay turns on.	Bus installation fault or defective slave board
Alm-306	Loss Communication With SIOB	If SIOB is configured AND { Communication between main controller with SIOB lost for 10 consecutive seconds OR SIOB (address 49) is not searched }	Automatic when communication comes back to normal	Unit shuts down. Alarm relay turns on.	Bus installation fault or defective slave board
Alm-307	LEN Scan Error	LEN communication error and LEN scan has been stopped.	Manual	Unit shuts down. Alarm relay turns on.	Check LEN bus hardware physical wiring and software log
Alm-308	Loss Communication With VFD	If vfd_opt = 2 AND {Communication between main controller with Carrier LV32 VFD lost for 10 consecutive seconds OR Carrier LV32 VFD (address 180) is not searched }	Automatic when communication comes back to normal	Unit shuts down. Alarm relay turns on.	Bus installation fault or defective slave board

Table 17 — PIC6 Alarm Codes* (cont)

ALARM CODE	DESCRIPTION OF ALARM TEXT	CRITERION FOR TRIP	ALARM RESET METHOD	ACTION TAKEN BY THE CONTROL	POSSIBLE CAUSE
Alm-309	Loss Communication With VFD Gateway (LEN)	If (vfd_opt = 3 or 4) AND {LEN side Communication between main controller with Modbus Gateway lost for 10 consecutive seconds OR Carrier Modbus Gateway (address 181) is not searched }	Automatic when communication comes back to normal	Unit shuts down. Alarm relay turns on.	Bus installation fault or defective slave board
Alm-310	Loss Communication With VFD (Modbus)	If (vfd_opt = 3/4/5/6/8) AND {Modbus side Communication between Modbus Gateway with VFD/Starter lost for 14 [default, can be configurable] consecutive seconds}	Automatic when communication comes back to normal	Unit shuts down. Alarm relay turns on.	Bus installation fault or defective slave board
Alm-311	Loss Communication With Danfoss VFD	If (vfd_opt = 7) AND {LEN side Communication error with VFD lost for 14 [default, can be configurable] consecutive seconds}	Automatic when communication comes back to normal	Unit shuts down. Alarm relay turns on.	If (vfd_opt = 7) AND {LEN side Communication error with VFD lost for 14 [default, can be configurable] consecutive seconds}
Alm-350	Sensor Fault - 19DV 1st Bearing Temp	Tested when the compressor is on whatever the run status and the communication between Main board and IOBs is ok, If compressor 1st Bearing Temp is outside range of -39.5 to 244.5°F	Automatic when communication comes back to normal	Unit shuts down. Alarm relay turns on.	Check sensor resistance. Check for proper wiring between 19DV 1st Bearing Temp Sensor and IOB connector. Check for disconnected, grounded, or shorted wiring.
Alm-350	Sensor Fault - 19DV 1st Stage Bearing Temp	Tested when the compressor is on whatever the run status and the communication between Main board and IOBs is ok, If compressor 2nd Bearing Temp is outside range of -39.5 to 244.5°F	Automatic when the temperature reading is inside the range of -39.5 to 244.5°F.	Unit shuts down. Alarm relay turns on.	Tested when the compressor is on whatever the run status and the communication between Main board and IOBs is OK, If compressor 1st Bearing Temp is outside range of -39.5 to 244.5°F. Check sensor resistance. Check for proper wiring between 19DV 2nd Bearing Temp Sensor and IOB connector. Check for disconnected, grounded, or shorted wiring.
Alm-351	Sensor Fault - 19DV 2nd Stage Bearing Temp	Tested when the compressor is on whatever the run status and the communication between Main board and IOBs is ok, If compressor 2nd Bearing Temp is outside range of -39.5 to 244.5°F	Automatic when the temperature reading is inside the range of -39.5 to 244.5°F.	Unit shuts down. Alarm relay turns on.	Tested when the compressor is on whatever the run status and the communication between Main board and IOBs is OK, If compressor 2nd Bearing Temp is outside range of -39.5 to 244.5°F. Check for proper wiring between 19DV 2nd Bearing Temp Sensor and IOB connector. Check for disconnected, grounded, or shorted wiring.
Alm-352	Sensor Fault - 19DV Pump Outlet Pressure	Tested when the compressor is whatever the run status and the communication between Main board and IOBs is ok, if Bearing Outlet Transducer voltage outside range of 0.3V to 4.67V	Automatic when the voltage reading is inside the range of 0.3V to 4.75V.	Unit shuts down. Alarm relay turns on.	Check 19DV Pump Outlet Pressure transducer wiring. Confirm that 5 V reference signal is available between IOB connector. Check for disconnected, grounded, or shorted wiring. Check for condensation in transducer connector.
Alm-353	Sensor Fault - Heat Reclaim Entering Temp	Tested when the compressor is on whatever the run status and the communication between Main board and IOBs is ok, If heat water entering temperature is outside range of -39.5 to 244.5°F	Automatic when the temperature reading is inside the range of -39.5 to 244.5°F.	Unit shuts down. Alarm relay turns on.	Tested when the compressor is on whatever the run status and the communication between Main board and IOBs is OK, If heat water entering temperature is outside range of -39.5 to 244.5°F
Alm-354	Sensor Fault - Heat Reclaim Leaving Temp	Tested when the compressor is on whatever the run status and the communication between Main board and IOBs is ok, If heat water leaving temperature is outside range of -39.5 to 244.5°F	Automatic when the temperature reading is inside the range of -39.5 to 244.5°F.	Unit shuts down. Alarm relay turns on.	Tested when the compressor is on whatever the run status and the communication between Main board and IOBs is OK, If heat water entering temperature is outside range of -39.5 to 244.5°F
Alm-425	VFD Fault - Single Cycle Dropout	cycle_1 = TRUE	Manual	Unit shuts down. Alarm relay turns on.	Temporary loss of voltage. Disable Single Cycle Dropout in CFGUMVFD screen.
Alm-426	VFD Fault - Line Current Imbalance	lineim_ = TRUE	Manual	Unit shuts down. Alarm relay turns on.	Check phase to phase and phase to ground power distribution bus voltage. Check Line Current Imbalance% in CFGUMVFD screen. Consult power company.
Alm-427	VFD Fault - High Line Voltage	hi_volt = TRUE	Manual	Unit shuts down. Alarm relay turns on.	Check phase to phase and phase to ground distribution bus voltage. Consult power company.
Alm-428	VFD Fault - Low Line Voltage	low_volt = TRUE	Manual	Unit shuts down. Alarm relay turns on.	Check phase to phase and phase to ground distribution bus voltage. Consult power company.
Alm-429	VFD Fault - Low DC Bus Voltage	lo_dcbus = TRUE	Manual	Unit shuts down. Alarm relay turns on.	Verify phase-to-phase and phase-to-ground line voltage. VFD Circuit Board malfunction. Call Carrier Service.
Alm-430	VFD Fault - High DC Bus Voltage	hi_dcbus = TRUE	Manual	Unit shuts down. Alarm relay turns on.	Verify phase to phase and phase to ground line voltage. Monitor AC line for high transient voltage conditions. VFD Circuit Board malfunction. Call Carrier Service
Alm-431	VFD Fault - VFD Power On Reset	vfd_por = TRUE	Manual	Unit shuts down. Alarm relay turns on.	Temporary loss of VFD control voltage. Check VFD control power breaker, transformer and fuses

Table 17 — PIC6 Alarm Codes* (cont)

ALARM CODE	DESCRIPTION OF ALARM TEXT	CRITERION FOR TRIP	ALARM RESET METHOD	ACTION TAKEN BY THE CONTROL	POSSIBLE CAUSE
Alm-432	VFD Fault - Ground Fault	grnd_ft = TRUE	Manual	Unit shuts down. Alarm relay turns on.	Check for condensation on motor terminals. Check motor power leads for phase to phase or phase to ground shorts. Disconnect motor from VFD and megger motor. Call Carrier Service.
Alm-433	VFD Fault - Line Phase Reversal	ph_rev = TRUE	Manual	Unit shuts down. Alarm relay turns on.	Reverse connections of any two line conductors to circuit breaker.
Alm-434	VFD Fault - Motor Overload Trip	motor_ov = TRUE	Manual	Unit shuts down. Alarm relay turns on.	Check VFD configurations Any phase current > 106% RLA. Can result from significant load side current imbalance when running at full load. Check entering condenser water temperature and water flow rate. Check Motor Rated Load Amps in CFGUMVFD screen.
Alm-435	VFD Fault - Rectifier Power Fault	rect_pu = TRUE	Manual	Unit shuts down. Alarm relay turns on.	Check VFD Status Malfunction within VFD Power Module. Call Carrier Service.
Alm-436	VFD Fault - Inverter Power Fault	inv_pu = TRUE	Manual	Unit shuts down. Alarm relay turns on.	Check VFD Status Malfunction within VFD Power Module. Call Carrier Service.
Alm-437	VFD Fault - Rectifier Overcurrent	rect_oi = TRUE	Manual	Unit shuts down. Alarm relay turns on.	Check VFD Status Check for high water temperatures or changes in water flow rates.
Alm-438	VFD Fault - Inverter Overcurrent	inv_oi = TRUE	Manual	Unit shuts down. Alarm relay turns on.	Check VFD Status Check for high entering water temperature or low condenser water flow. Check current settings in CFGUMVFD screen.
Alm-439	VFD Fault - Condenser High Pressure	prs_trip = TRUE	Manual	Unit shuts down. Alarm relay turns on.	Check Compressor Discharge High Pressure switch wiring and accuracy. Check for high condenser water temperatures, low water flow, fouled tubes. Check for division plate/gasket bypass. Check for noncondensables in refrigerant.
Alm-440	VFD Fault - Motor Amps Not Sensed	no_amps = TRUE	Manual	Unit shuts down. Alarm relay turns on.	Check main circuit breaker for trip. Increase Current % Imbalance in CFGUMVFD screen.
Alm-441	VFD Fault - Motor Acceleration Fault	accelflt = TRUE	Manual	Unit shuts down. Alarm relay turns on.	Check that inlet guide vanes are fully closed at start-up. Check Motor Rated Load Amps in CFGUMVFD screen. Reduce unit pressure if possible.
Alm-442	VFD Fault - Stop Fault	ampstop = TRUE	Manual	Unit shuts down. Alarm relay turns on.	Check Inverter Power Unit VFD Circuit Board malfunction. Call Carrier Service.
Alm-443	VFD Fault - Rectifier Overtemp	rect_ot = TRUE	Manual	Unit shuts down. Alarm relay turns on.	Check Cooling and VFD Config. Check that VFD refrigerant isolation valves are open. Check VFD refrigerant cooling solenoid and refrigerant strainer. Check for proper VFD cooling fan operation and blockage.
Alm-444	VFD Fault - Inverter Overtemp	inv_ot = TRUE	Manual	Unit shuts down. Alarm relay turns on.	Check Cooling and VFD Config. Check that VFD refrigerant isolation valves are open. Check VFD refrigerant cooling solenoid and refrigerant strainer. Check for proper VFD cooling fan operation and blockage.
Alm-445	VFD Fault - Motor Current Imbalance	motim_j = TRUE	Manual	Unit shuts down. Alarm relay turns on.	Check Motor Current Imbalance% in CFGUMVFD screen.
Alm-446	VFD Fault - Line Voltage Imbalance	lineim_v = TRUE	Manual	Unit shuts down. Alarm relay turns on.	Check phase-to-phase and phase-to-ground distribution bus voltage. Increase Line Voltage Imbalance% in CFGUMVFD screen.
Alm-447	VFD Fault - Frequency Fault	freqflt = TRUE	Manual	Unit shuts down. Alarm relay turns on.	Check Power Supply If operating from a generator, check generator size and speed. Check utility power supply.
Alm-448	VFD Fault - VFD Comm Fail	vfd_comm = TRUE	Manual	Unit shuts down. Alarm relay turns on.	Check VFD communication wiring and connectors. Check status lights on DPI Communications Interface Board. Call Carrier Service.
Alm-449	VFD Fault - VFD Fault	vfdfault = TRUE	Manual	Unit shuts down. Alarm relay turns on.	Check fault code and possible cause in corresponding type of VFD user manuals. Call Carrier Service
Alm-450	VFD Fault - VFD Start Inhibit	strt_inh = TRUE	Manual	Unit shuts down. Alarm relay turns on.	The VFD Start Inhibit is derived from the Alarm bit being set in the VFD. The conditions causing the alarm must be corrected in the VFD to enable subsequent starts and operation
Alm-451	VFD Fault - VFD Checksum Error	checksum = TRUE	Manual	Unit shuts down. Alarm relay turns on.	Press Reset to Restore Configuration. Actual VFD checksum does not match calculated value.
Alm-452	VFD Fault - Inductor Overtemp Switch	inot_sw = TRUE	Manual	Unit shuts down. Alarm relay turns on.	Check Temp Switch and Cooling Fans. Check for cooling fan air flow obstructions
Alm-453	VFD Fault - Incompatibility Fault	incomp = TRUE	Manual	Unit shuts down. Alarm relay turns on.	Load compatible version files into drive

Table 17 — PIC6 Alarm Codes* (cont)

ALARM CODE	DESCRIPTION OF ALARM TEXT	CRITERION FOR TRIP	ALARM RESET METHOD	ACTION TAKEN BY THE CONTROL	POSSIBLE CAUSE
Alm-454	VFD Fault - Main Power Failure		Manual	Unit shuts down. Alarm relay turns on.	Check the main power to VFD
Alm-500	VFD Fault - Brake Check	Danfoss VFD alarm	Manual	Unit shuts down. Alarm relay turns on.	Refer to Danfoss VFD troubleshooting manual
Alm-501	VFD Fault - Power Card Over Temperature	Danfoss VFD alarm	Manual	Unit shuts down. Alarm relay turns on.	Refer to Danfoss VFD troubleshooting manual
Alm-502	VFD Fault - Earth Fault	Danfoss VFD alarm	Manual	Unit shuts down. Alarm relay turns on.	Refer to Danfoss VFD troubleshooting manual
Alm-503	VFD Fault - Ctrl Card Over Temperature	Danfoss VFD alarm	Manual	Unit shuts down. Alarm relay turns on.	Refer to Danfoss VFD troubleshooting manual
Alm-504	VFD Fault - Control Word Timeout	Danfoss VFD alarm	Manual	Unit shuts down. Alarm relay turns on.	Refer to Danfoss VFD troubleshooting manual
Alm-505	VFD Fault - Over Current	Danfoss VFD alarm	Manual	Unit shuts down. Alarm relay turns on.	Refer to Danfoss VFD troubleshooting manual
Alm-506	VFD Fault - Torque Limit	Danfoss VFD alarm	Manual	Unit shuts down. Alarm relay turns on.	Refer to Danfoss VFD troubleshooting manual
Alm-507	VFD Fault - Motor Thermistor Over Temp	Danfoss VFD alarm	Manual	Unit shuts down. Alarm relay turns on.	Refer to Danfoss VFD troubleshooting manual
Alm-508	VFD Fault - Motor Etr Over Temperature	Danfoss VFD alarm	Manual	Unit shuts down. Alarm relay turns on.	Refer to Danfoss VFD troubleshooting manual
Alm-509	VFD Fault - Inverter Overload	Danfoss VFD alarm	Manual	Unit shuts down. Alarm relay turns on.	Refer to Danfoss VFD troubleshooting manual
Alm-510	VFD Fault - DC Link Under Voltage	Danfoss VFD alarm	Manual	Unit shuts down. Alarm relay turns on.	Refer to Danfoss VFD troubleshooting manual
Alm-511	VFD Fault - DC Link Over Voltage	Danfoss VFD alarm	Manual	Unit shuts down. Alarm relay turns on.	Refer to Danfoss VFD troubleshooting manual
Alm-512	VFD Fault - Short Circuit	Danfoss VFD alarm	Manual	Unit shuts down. Alarm relay turns on.	Refer to Danfoss VFD troubleshooting manual
Alm-513	VFD Fault - Inrush Fault	Danfoss VFD alarm	Manual	Unit shuts down. Alarm relay turns on.	Refer to Danfoss VFD troubleshooting manual
Alm-514	VFD Fault - Mains Phase Loss	Danfoss VFD alarm	Manual	Unit shuts down. Alarm relay turns on.	Refer to Danfoss VFD troubleshooting manual
Alm-515	VFD Fault - AMA Not OK	Danfoss VFD alarm	Manual	Unit shuts down. Alarm relay turns on.	Refer to Danfoss VFD troubleshooting manual
Alm-516	VFD Fault - Live Zero Error	Danfoss VFD alarm	Manual	Unit shuts down. Alarm relay turns on.	Refer to Danfoss VFD troubleshooting manual
Alm-517	VFD Fault - Internal Fault	Danfoss VFD alarm	Manual	Unit shuts down. Alarm relay turns on.	Refer to Danfoss VFD troubleshooting manual
Alm-518	VFD Fault - Brake OverLoad	Danfoss VFD alarm	Manual	Unit shuts down. Alarm relay turns on.	Refer to Danfoss VFD troubleshooting manual
Alm-519	VFD Fault - Motor Phase U Is Missing	Danfoss VFD alarm	Manual	Unit shuts down. Alarm relay turns on.	Refer to Danfoss VFD troubleshooting manual
Alm-520	VFD Fault - Motor Phase V Is Missing	Danfoss VFD alarm	Manual	Unit shuts down. Alarm relay turns on.	Refer to Danfoss VFD troubleshooting manual
Alm-521	VFD Fault - Motor Phase W Is Missing	Danfoss VFD alarm	Manual	Unit shuts down. Alarm relay turns on.	Refer to Danfoss VFD troubleshooting manual
Alm-522	VFD Fault - Field Bus Fault	Danfoss VFD alarm	Manual	Unit shuts down. Alarm relay turns on.	Refer to Danfoss VFD troubleshooting manual
Alm-523	VFD Fault - 24V Supply Fault	Danfoss VFD alarm	Manual	Unit shuts down. Alarm relay turns on.	Refer to Danfoss VFD troubleshooting manual
Alm-524	VFD Fault - Mains Failure	Danfoss VFD alarm	Manual	Unit shuts down. Alarm relay turns on.	Refer to Danfoss VFD troubleshooting manual
Alm-525	VFD Fault - 1.8V Supply Fault	Danfoss VFD alarm	Manual	Unit shuts down. Alarm relay turns on.	Refer to Danfoss VFD troubleshooting manual
Alm-526	VFD Fault - Brake Resistor Short Circuit	Danfoss VFD alarm	Manual	Unit shuts down. Alarm relay turns on.	Refer to Danfoss VFD troubleshooting manual
Alm-527	VFD Fault - Brake IGBT Fault	Danfoss VFD alarm	Manual	Unit shuts down. Alarm relay turns on.	Refer to Danfoss VFD troubleshooting manual
Alm-528	VFD Fault - Option Change	Danfoss VFD alarm	Manual	Unit shuts down. Alarm relay turns on.	Refer to Danfoss VFD troubleshooting manual
Alm-529	VFD Fault - Drive Initialized	Danfoss VFD alarm	Manual	Unit shuts down. Alarm relay turns on.	Refer to Danfoss VFD troubleshooting manual
Alm-530	VFD Fault - Safe Stop	Danfoss VFD alarm	Manual	Unit shuts down. Alarm relay turns on.	Refer to Danfoss VFD troubleshooting manual
Alm-531	VFD Fault - Service Trip_Read/Write	Danfoss VFD alarm	Manual	Unit shuts down. Alarm relay turns on.	Refer to Danfoss VFD troubleshooting manual
Alm-532	VFD Fault - End Of Curve	Danfoss VFD alarm	Manual	Unit shuts down. Alarm relay turns on.	Refer to Danfoss VFD troubleshooting manual
Alm-533	VFD Fault - Broken Belt	Danfoss VFD alarm	Manual	Unit shuts down. Alarm relay turns on.	Refer to Danfoss VFD troubleshooting manual
Alm-534	VFD Fault - Fans Error	Danfoss VFD alarm	Manual	Unit shuts down. Alarm relay turns on.	Refer to Danfoss VFD troubleshooting manual
Alm-535	VFD Fault - PTC1 Safe Stop	Danfoss VFD alarm	Manual	Unit shuts down. Alarm relay turns on.	Refer to Danfoss VFD troubleshooting manual
Alm-536	VFD Fault - Dangerous Failure	Danfoss VFD alarm	Manual	Unit shuts down. Alarm relay turns on.	Refer to Danfoss VFD troubleshooting manual

* This Alarm table is not specific to 19DV. References to oil are not associated with 19DV product.

Event States

An event state is a specific set of conditions that the controller may encounter when controlling the chiller. Event states are repeatable and predictable, and represent known states of the control. When the control is in a particular state, a unique message is associated with that state. The event state messages are displayed on the default screen of the control panel and are listed in Table 18.

Table 18 — Event States

EVENT NO.	DESCRIPTION
1	Chiller Off
2	Chiller Tripout
3	Pumpdown/Lockout
4	Terminate Pumpdown/Lockout
5	Guide Vane Calibration
6	Quick Test in Progress
7	Ice Build Done
8	Ice Build in Progress
9	Free Cooling in Progress
10	Auto Restart Pend
11	Condenser Flush in Progress
13	Envelope Control Valve Calibration
14	Damper Valve Calibration
15	The 1st time 30-Min Ref Lubricating
20	Startup Inhibited - Loadshed in Effect
21	Prestart Check in Progress
22	Timeout - Delay to Start in
23	Recycle in Progress
24	Startup in Progress
25	Swift Restart In Progress
30	Ramp Loading - Temperature
31	Ramp Loading - Motor Load
32	Ramp Loading - Capacity Inhibit
35	Demand Limit - by Local Signal
36	Demand Limit - by 4-20 mA
37	Demand Limit - by Network Command
38	Demand Limit - by Loadshed Redline
39	Demand Limit - Capacity Inhibit
40	Demand Limit - Capacity Decrease
41	Demand Limit - Inhibit Clamp
45	Override - High Condenser Pressure
47	Override - High Motor Temperature
48	Override - Low Evap Refrig Temp
49	Override - High Compressor Lift
50	Override - High Bearing Temp
51	Override - Low Discharge Superheat
52	Override - Manual VFD Speed Target
53	Override - High Motor Current
54	Override - High Discharge Temp
55	Override - Low Source Temp
60	Running - Temp Reset by 4-20mA Signal
61	Running - Temp Reset by Remote Temp Sensor
62	Running - Temp Reset by Water DT
63	Running - Cooling Leaving Chilled Water
64	Running - Cooling Entering Chilled Water
65	Running - Heating Leaving Cond Water
66	Running - Heating Entering Cond Water
67	Envelope Control - Surge Correction
68	Envelope Control - Acts Before Recycle Shutdown
69	Envelope Control - Low Load Application
70	Envelope Control - Forced
71	Running - VFD Rampdown
72	Running - Guide Vane 1 Position Forced
73	Running - VFD Speed Forced
74	Optimal Operation
75	Surge Prevention
76	Surge Protection
77	Running - VFD Overcurrent
78	Envelope Control - Delta Tx

Table 18 — Event States (cont)

EVENT NO.	DESCRIPTION
79	Running - Damper Valve Forced
80	Operation - Oil EXV Forced
81	Running - Head Pressure Valve Forced
82	Purge - Forced
83	Running - Guide Vane 2 Position Forced
84	Operation - Refrigerant Lub Forced
85	Running - Vapor Source Valve Forced
90	Shutdown - Normal
91	Shutdown - Alarm
93	Shutdown - Recycle
94	Shutdown - Recycle Ice Build
95	Shutdown - Compressor Deenergized
96	Shutdown - Emergency Stop
97	Transducer Calibration in Effect
98	ISM Calibration in Effect

CONTROLLER SETTINGS

The controller settings are accessible through the Configuration Menu when logged into the Factory account.

Unit IP Address

On the Configuration Menu screen, press Ethernet Configuration to display the network parameters. See Fig. 46.

NOTE: You must request an IP address, the subnet mask, and the default gateway from the system administrator before connecting the unit to the local Ethernet network.

To change IP address manually, select Ethernet Configuration from the System Configuration Menu. See Fig. 46.

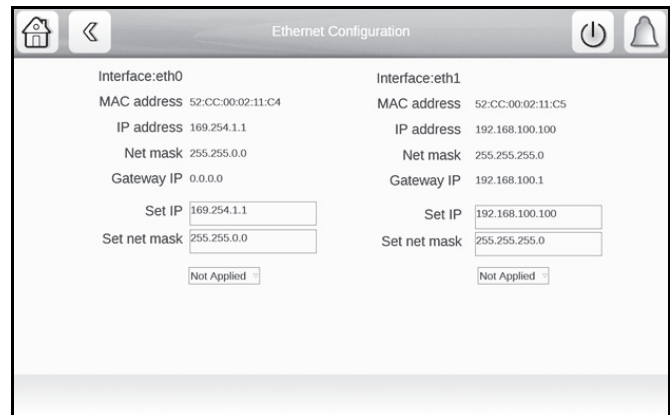

Fig. 46 — Ethernet Configuration

Enter the new address and validate it by pressing Apply. Return to the Network screen and enter the subnet mask and default gateway using the same method. Then return to the application and save the changes. See Fig. 47.

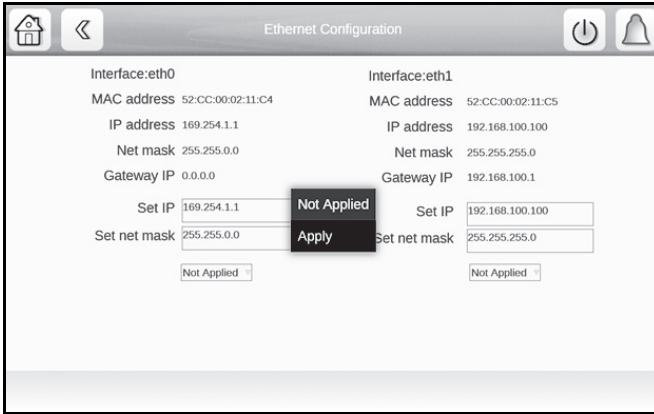

Fig. 47 — Save Changes

System Configuration

On the Control Identification screen, the device identification, software version and CCN information are shown. See Fig. 48.

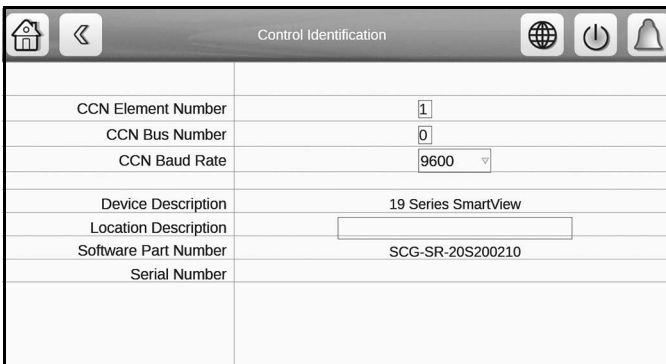

Fig. 48 — Control Identification Screen

Table 19 — Hardware Problems

SYMPTOMS	POSSIBLE CAUSES	CHECKS	SOLUTIONS
The unit does not respond to the instructions sent by the supervision PC on the CCN bus.	Problem at the RS485 converter level of the PC or connection problem on the primary CCN bus.	Check the CCN cable connections. The unit CCN address is 0.1 and the communication speed is 9600 baud by default.	Replace the RS485 connector.
Communication problem when connecting two buses (primary bus and secondary bus).	Electrical problem between 0 v CCN of the primary bus and 0 v CCN of the secondary bus.	Check the connection of the metal part of the interface casing to earth.	Connect the metal part of the interface casing to earth.

Table 20 — Web Interface Problems

SYMPTOMS	POSSIBLE CAUSES	CHECKS	SOLUTIONS
Start-up page loads, then goes to fault state.	Network property details are not valid.	Check the network parameters (see the section Ethernet/IP Connection Problems on page 44).	Contact your system administrator.
	Ethernet network is not available.	Check to see if the orange LED on the unit is flashing.	Check the Ethernet connection to the local network if the orange LED does not flash.
While accessing the unit via the web browser, the Java platform launches, but remains blocked. No file is loaded.	Proxy server problem in the local network.	Contact your system administrator.	In agreement with the system administrator, open the Runtime Java control panel and select Direct Connection in the system parameters and/or request in the web browser (Tools → Options → Connection → System parameters) that no proxy server is used to go to the local addresses. If possible, uncheck "use of an automatic configuration script." Restart the web browser.
The application has been launched, but the screens are not shown in the web browser.	A proxy server is used to access the unit and this supplies the old screens to the browser. Incorrect configuration of the Java application.	Check that the web browser does not go via a proxy server to access the unit. Check that the Java application does not store the internet files on the PC.	Open the browser and in the system connection parameters add the IP address of the unit in the proxy exceptions. (Tools → Options → Connection → System parameters → "No proxy for"). See the section Java Application Configuration on page 45.
Cannot connect via http server	HTTP Server = Disable under Network Configuration Menu	Check status in Network Configuration Menu screen.	Set value to requirements.

NOTES:

1. The unit cannot automatically obtain the network parameters via a DHCP (Dynamic Host Configuration Protocol) server.
2. The intranet site address of the unit is the IP address.

TOUCH SCREEN CALIBRATION

Depending on the user and the position of the panel, it may be necessary to calibrate the touch screen if the cursor does not move precisely with the user's touch. When the user presses and holds an inactive part of the screen for 10 seconds, the screen will turn black with white text displaying "Calibrating Touch Screen" and white cross hairs. Touch the center of the cross-hair sight with a touch pen or similar blunt-ended stylus (do not use a metal object). When the cross-hair sight is touched, it moves to a new position; touch the center of the cross hairs again. When all positions have been configured, the calibration is complete and the screen returns to the Home Screen.

COMMUNICATION PROBLEMS

Hardware Problems

See Table 19 for potential communication issues caused by hardware problems.

Web Interface Problems

See Table 20 for potential communication issues caused by web interface issues. The intranet site of the unit is the IP address (see Unit IP Address on page 42).

NOTE: The unit cannot automatically obtain the network parameters via a DHCP server.

Ethernet/IP Connection Problems

Use the following methods to troubleshoot:

UNIT IS POINT-TO-POINT CONNECTED TO A PC

Ensure controller is powered on prior to configuration and check Ethernet connection and PC Network Interface Card (NIC).

NOTE: In addition to the following procedure, it may be necessary to check the Ethernet connection and/or configure the PC network board.

In Network Settings, open Local Area Connection Properties. Select Internet Protocol and click Properties. See Fig. 49.

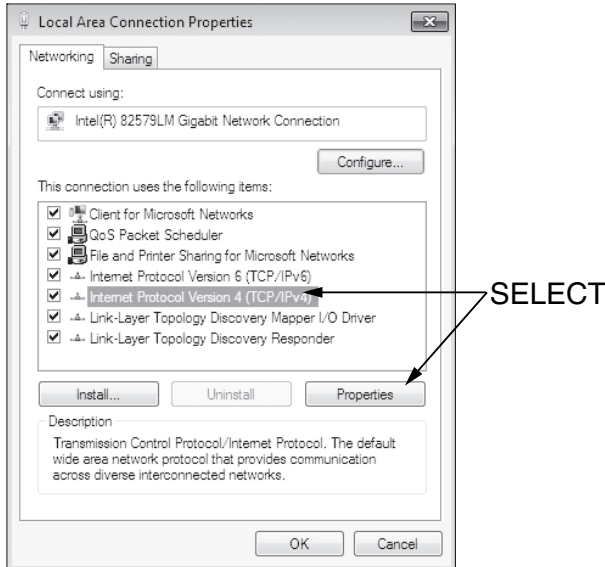

Fig. 49 — Local Area Connection Properties

The Internet Protocol Properties window is displayed.

- If no IP address is configured in the General and Alternative Configuration tabs, the unit IP address must be configured to 169.254.xxx.xxx. Modify the unit IP address and then restart the system.
- If the PC has a fixed IP address configured in one of the two tabs (General and Alternative Configuration), the IP address of the PC and the unit IP address must have the system and sub-system fields in common. The last part of the IP address is the host number and must be unique on the sub-system. For example: Unit address — 172.30.101.11 and PC address — 172.30.101.182. In this example, 172.30 corresponds to the network, and 101 corresponds to the sub-system. Carry out the necessary modifications and try to access the unit again.

In the case of a problem, open a Windows command window (Start, Execute, type **cmd** and press Enter), then type the command **ping**, followed by the unit IP address. In the example shown in Fig. 50, the PC receives four positive responses (replies).

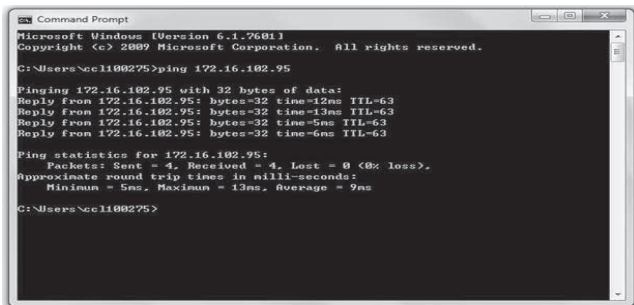

Fig. 50 — Ping — Positive Replies

In the example shown in Fig. 51, the PC receives four negative responses (request timed out).

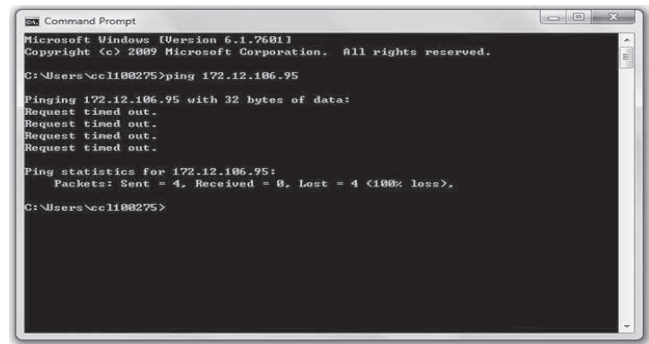

Fig. 51 — Ping — Negative Responses

If the PC receives four negative responses, check the internet browser parameters to determine if a proxy server or an automatic configuration script has been configured. If this is the case:

- Deselect the proxy server or the configuration script and restart the browser,
- Or refer to the section Java Application Configuration (page 45).

Try to access the unit again. If the PC still does not receive a response from the unit, restart the unit. Contact your system administrator.

UNIT IS CONNECTED TO THE LOCAL NETWORK

The unit is connected to the local network by an uncrossed cable, and the unit is energized. Open a Windows command window (Start, Execute, type **cmd** and press Enter), then type the command **ping**, followed by the unit IP address.

If the responses are positive (see Fig. 50), the internet browser configuration is faulty. Check the system parameters of the internet browser to determine if a proxy server or an automatic configuration script has been configured (**Tools** → **Internet Options** → **Connections** → **System Parameters**). See Fig. 52.

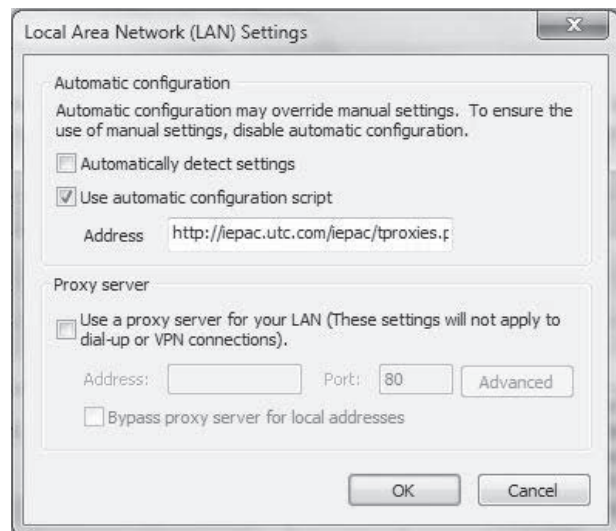

Fig. 52 — Local Area Network Settings

If a proxy server is used, add the unit IP address to the exceptions list of the proxy server (advanced proxy configuration). See Fig. 53.

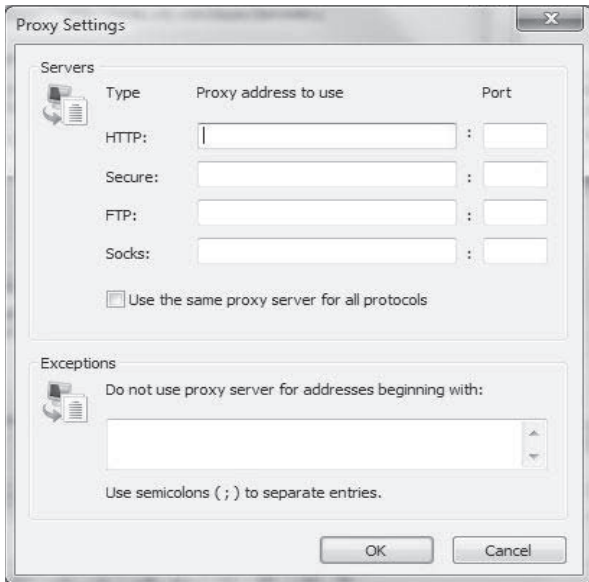

Fig. 53 — Proxy Settings

If a configuration script is used, it is not possible to add the unit IP address to the exceptions list. In this case, see the section Java Application Configuration below.

If the response to the “ping” command is negative, verify the IP address of the PC and the IP address of the unit. They must have the system network and sub-system in common. The last part of the IP address is the host number and must be unique on the sub-system; for example: Unit address — 172.30.101.11 and PC address — 172.30.101.182. In this example, 172.30 corresponds to the system network, and 101 corresponds to the sub-system. The host numbers are 11 and 182 respectively.

ETHERNET CONNECTION ON THE PC

Open the network configuration window of the PC and double-click Network Connections. Find the system interface board and check that no red “X” appears on the icon.

The connection to the local network must be authorized and in the connected status. If this is not the case, check the connections and authorize/repair the network connection.

JAVA APPLICATION CONFIGURATION

Open the Internet configuration window of the PC and double-click the Java application icon. If Java is not installed, a free download is available at <http://www.java.com>.

If Java has already been installed, check if it is used by other applications. If so, check that these are compatible with the following settings in the Java control panel. See Fig. 54.

- Network settings: In the Java Control Panel, click Network Settings. Select a direct connection to bypass the proxy server or select the automatic configuration script. See Fig 55.
- Temporary internet files: In the Java Control Panel, click Settings in the Temporary Internet Files section. Be sure the setting **Keep temporary files on my computer** is unchecked (clear). See Fig. 56.

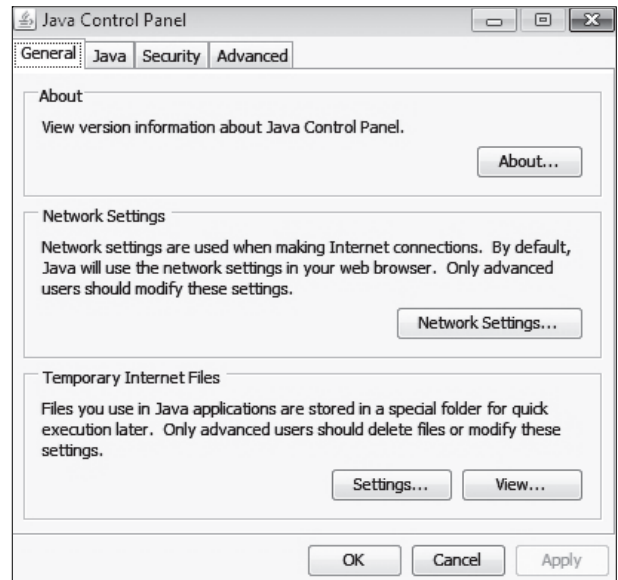

Fig. 54 — Java Control Panel

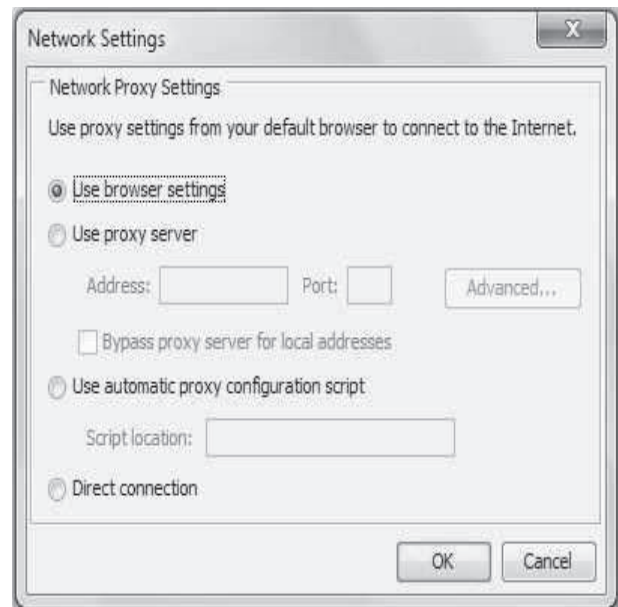

Fig. 55 — Network Settings

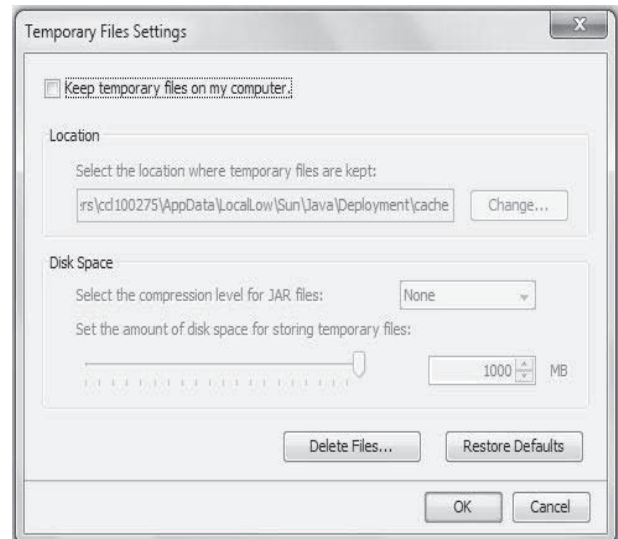

Fig. 56 — Temporary File Settings

APPENDIX A — PIC6 SCREEN AND TABLE STRUCTURE

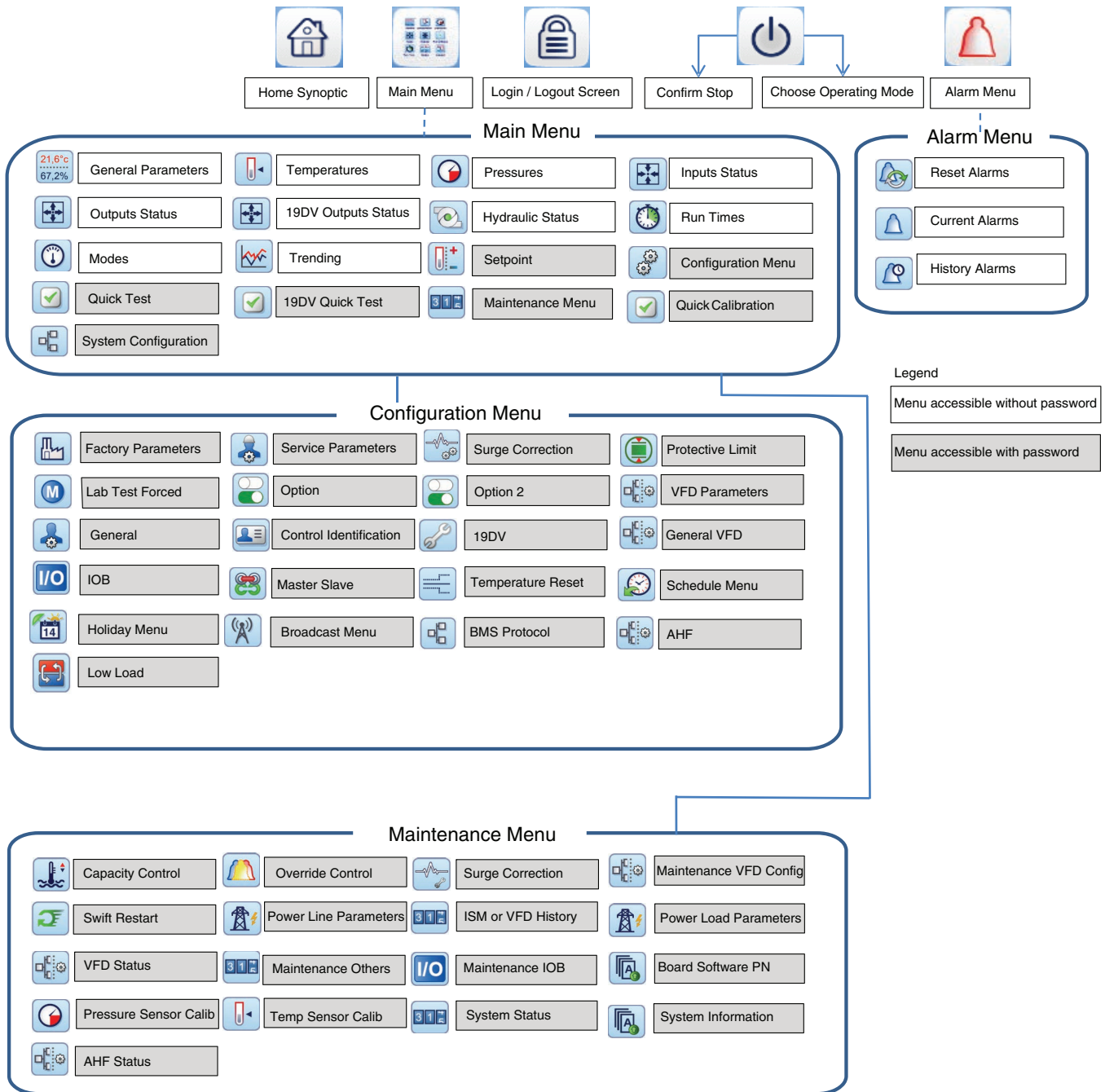

Fig. A — 19DV Screen Structure

APPENDIX A — PIC6 SCREEN AND TABLE STRUCTURE (CONT)

Main Menu Description

ICON	DISPLAYED TEXT*	ACCESS	ASSOCIATED TABLE	PAGE NO.
	General Parameters	All	GENUNIT	48
	Temperatures	All	TEMP	49
	Pressures	All	PRESSURE	49
	Inputs Status	All	INPUTS	50
	Outputs Status	All	OUTPUTS	51
	19DV Outputs Status	All	DV_OUT	51
	Hydraulic Status	All	HYDRLIC	52
	Run Times	All	RUNTIME	52
	Modes	All	MODES	53
	Trending	All	TRENDING	—
	Setpoint	User	SETPOINT	53
	Configuration Menu	User	CONFIG	54
	Quick Test	Service	QCK_TEST	64
	19DV Quick Test	Service	QCK_DV	65
	Quick Calibration	Service	QCK_CALI	66
	Maintenance Menu	User: Power Line Parameters, Power Load Parameters	MAINTAIN	67
	System Configuration	User; Service - Date/Time Config; All	N/A	80

* Displayed text depends on the selected language (default is English).

APPENDIX A — PIC6 SCREEN AND TABLE STRUCTURE (CONT)

NOTE: This software is shared between multiple product families and therefore not all points indicated in the tables are applicable to 19DV or 19XR as configured. For instance 19DV is not an oil lubricated machine, so any reference to oil in the software tables would not be applicable for 19DV.

General Parameters

CCN TABLE NAME: GENUNIT						
PIC6 PATH: Main Menu → General Parameters						
LINE	PIC6 DESCRIPTION	CCN NAME	RANGE	DEFAULT VALUE*	UNIT	READ/WRITE
1	Control Mode 0 = Local, 1 = Network 2 = Remote, 3 = Local Sched	ctl_mode	0 to 3			RO
2	Compressor1 Run Status	cm_stas1	0 to 16†			RO
3	Deter Start Stop Command	stop/start				RO
4	Network: Cmd Start/Stop	CHIL_S_S	NO/YES			RW**
5	Network:Cmd Occupied	CHIL_OCC	NO/YES			RW**
6	Cooling / Heating Select	HC_SEL	COOL/HEAT	COOL		RW
7	Control Point	CTRL_PNT	10.0 to 160.0		°F	RW**
8	Control Point Reset	reset	-30.00 to 30.00		°F	RO
9	Actual Setpoint	setpoint	10.0 to 150.0		°F	RO
10	Percent Current	AMPS_P	0.0 to 999.0		%	RO
11	Motor Percent Kilowatts	KW_P	0 to 100		%	RO
12	Calculated Capacity	cal_capa	0 to 100		%	RO
13	Actual Demand Limit	DEM_LIM	10.0 to 100.0	100	%	RW**
14	Emergency Stop	EMSTOP	NO/YES	0		RW**
15	Chiller Status Number	ch_state	0 to 500			RO
16	Local Schedule Occupied	oc_occ	NO/YES			RO
17	Ice Schedule Occupied	ice_occ	NO/YES			RO
18	Master Slave Start Stop	ms_stsp	STOP/START			RO
19	Remote Reset Alarm	REM_RST	NO/YES			RO
20	Stop Override	STP_OVER	NO/YES	NO		RW
21	Start Condenser Flush	CF_START	NO/YES	NO		RW
22	BACnet Occupied	BAC_OCC	NO/YES			RO

LEGEND

RO — Read Only
RW — Read/Write

* Default value is shown only if configurable in this table.

† 0 = OFF 9 = AUTORST
1 = CTLTEST 10 = RAMPING
2 = PUMPDOWN 11 = RUNNING
3 = LOCKOUT 12 = OVERRIDE
4 = RECYCLE 13 = DEMAND
5 = TRIPOUT 14 = SHUTDOWN
6 = TIMEOUT 15 = FREECOOL
7 = PRESTART 16 = CONDFLSH
8 = STARTUP

** RW from network.

NOTE: The PIC6 controls platform is utilized across multiple product lines. In this appendix, all PIC6 software lines are shown; as configured for 19DV in v2.3 software. Not all lines may be applicable for the 19DV product.

APPENDIX A — PIC6 SCREEN AND TABLE STRUCTURE (CONT)

Temperatures

CCN TABLE NAME: TEMP

PIC6 PATH: Main Menu → Temperatures

LINE	PIC6 DESCRIPTION	CCN NAME	RANGE	DEFAULT VALUE*	UNIT	READ/WRITE
1	Entering Chilled Water	ECW	-40.0 to 245		°F	RO
2	Leaving Chilled Water	LCW	-40.0 to 245		°F	RO
3	Entering Condenser Water	ECDW	-40.0 to 245		°F	RO
4	Leaving Condenser Water	LCDW	-40.0 to 245		°F	RO
5	Evap Sat Refrig Temp	EVAP_SAT	-40.0 to 245		°F	RO
6	Evap Refrig Liquid Temp	EVAP_T			°F	RO
7	Evaporator Approach	evap_app	0.0 to 99.0		°F	RO
8	Condenser Approach	cond_app	0.0 to 99.0		°F	RO
9	Cond Sat Refrig Temp	COND_SAT	-40.0 to 245		°F	RO
10	Purge Comp Suction Temp	PGC_SUUCT, SAT	-40.0 to 245		°F	RO
11	BRG Ref Supply Sat Temp	BRGI_T	-40.0 to 245		°F	RO
12	Purge Inlet Temp	PGINTMP	-40.0 to 245		°F	RO
13	Comp Discharge Temp	DGT	-40.0 to 245		°F	RO
14	Discharge Superheat	DSH	-20.0 to 99.0		°F	RO
15	Motor Winding 1 Temp,	MTRW1,	-40.0 to 245		°F	RO
16	Remote Reset Temp	R_RESET	-40.0 to 245		°F	RO
17	1st Stage Bearing Temp	CBH1_T	-40.0 to 245		°F	RO
18	2nd Stage Bearing Temp	CBH2_T	-40.0 to 245		°F	RO
19	Common CHWS Temp	CHWS_T	-40.0 to 245		°F	RO
20	Common CHWR Temp	CHWR_T	-40.0 to 245		°F	RO

Pressures (Associated Table: PRESSURE)

CCN TABLE NAME: PRESSURE

PIC6 PATH: Main Menu → Pressures

LINE	PIC6 DESCRIPTION	CCN NAME	RANGE	DEFAULT VALUE*	UNIT	READ/WRITE
1	Evaporator Pressure	EVAP_P	-15.0 to 250.0		psig	RO
2	Condenser Pressure	COND_P	-15.0 to 250.0		psig	RO
3	Economizer Pressure	ECON_P	-15.0 to 250.0		psig	RO
4	Oil/Ref Delta P Offset	pd_off	-5.0 to 5.0	0.0	psi	RW
5	Bearing Inlet Pressure	BRGI_P	-15.0 to 250.0		psid	RO
6	Bearing Outlet Pressure	BRGO_P	-15.0 to 250.0		psid	RO
7	Bearing Delta P	REF_PD	-15.0 to 250.0		psid	RO
8	Pump Output Pressure	PUMPO_P	-15.0 to 250.0		psig	RO
9	Pump Input Pressure	PUMPI_P	-15.0 to 250.0		psig	RO
10	Ref Pump Delta P	PUMP_PD	-15.0 to 250.0		psid	RO

LEGEND

RO — Read Only
RW — Read/Write

*Default value is shown only if configurable in this table.

APPENDIX A — PIC6 SCREEN AND TABLE STRUCTURE (CONT)

Inputs Status

CCN TABLE NAME: INPUTS

PIC6 PATH: Main Menu → Inputs Status

LINE	PIC6 DESCRIPTION	CCN NAME	RANGE	DEFAULT VALUE*	UNIT	READ/WRITE
1	EC Valve Status 0=Closed, 1=Interim, 2=Opened, 3=Failure	HGBP_ACT	0 to 3			RO
2	High Pressure Switch	HP_SW	OPEN/CLOSE			RO
3	Remote Contact	REM_CON	OPEN/CLOSE			RO
4	Emergency Stop Contact	E_STOP	OPEN/CLOSE			RO
5	Ice Build Contact	ICE_CON	OPEN/CLOSE			RO
6	Chiller Lockout	REM_LOCK	OPEN/CLOSE			RO
7	Spare Safety Input	SAFETY	OPEN/CLOSE			RO
8	Starter Fault Feedback	STARTFLT	OPEN/CLOSE			RO
9	Fire Security Interlock	FS_LOCK	OPEN/CLOSE			RO
10	Guide Vane 1 Actual Pos	GV1_ACT			%	RO
11	Guide Vane 2 Actual Pos	GV2_ACT			%	RO
12	Actual VFD Speed Per	VFD_ACT			%	RO
13	Auto Demand Limit Input	AUTO_DEM			mA	RO
14	Auto Water Temp Reset	AUTO_RES			mA	RO
15	Refrig Leak Sensor	REF_LEAK			mA	RO
16	VFD Speed Feedback	VFD_IN			V	RO
17	Guide Vane 1 Pos Feedback	GV1_MA			mA	RO
18	Guide Vane 2 Pos Feedback	GV2_MA			mA	RO
19	VFD Current Input	VFDC_MA			mA	RO
20	Actual ECV Pos Per	HGBPACTP			%	RO
21	ECV Current Feedback	HGBP_MA			mA	RO
22	Free Cool Start Switch	FC_SS	Off/On			RO
23	Purge Level Switch Low	PGLI_LO	OPEN/CLOSE			RO
24	Purge Level Switch High	PGLI_HI	OPEN/CLOSE			RO
25	Liquid Level Switch	HF_LS	OPEN/CLOSE			RO

LEGEND

RO — Read Only

*Default value is shown only if configurable in this table.

APPENDIX A — PIC6 SCREEN AND TABLE STRUCTURE (CONT)

Outputs Status

CCN TABLE NAME: OUTPUTS

PIC6 PATH: Main Menu → Outputs Status

LINE	PIC6 DESCRIPTION	CCN NAME	RANGE	DEFAULT VALUE*	UNIT	READ/WRITE
1	Guide Vane1 Output	GV1_OUT	0 to 20		mA	RO
2	Chiller Status (Analog)	CHST_OUT	4 to 20		mA	RO
3	Chiller Status (Discrete)	RUN_STAT	OFF/ON		OFF/ON	RO
4	Alarm Relay	ALM	OFF/ON		OFF/ON	RO
5	Alert Relay	ALE	OFF/ON		OFF/ON	RO
6	Compressor Start Relay	COMP_SR	OFF/ON		OFF/ON	RO
7	Starter Trans Sw Status	TRANS	OFF/ON		OFF/ON	RO
8	Liquid Bypass VLV Target	LQBP_TGT	0 to 100		%	RO
9	Liquid Bypass VLV mA	LQBP_VLV	4 to 20		mA	RO
10	EC/HG Valve Tgt Pos 0=Close,1=Hold, 2=Open	hgbp_tgt	0 to 2			RO
11	EC/HG Valve Output mA	HGBP_OUT	4 to 20		mA	RO
12	Tower Fan Relay High	TFR_HIGH	OFF/ON		OFF/ON	RO
13	Tower Fan Relay Low	TFR_LOW	OFF/ON		OFF/ON	RO
14	Free Cooling Mode	FC_MODE	NO/YES			RO

LEGEND

*Default value is shown only if configurable in this table.

RO — Read Only

19DV Outputs Status

CCN TABLE NAME: OUTPUTS

PIC6 PATH: Main Menu → 19DV Outputs Status

LINE	PIC6 DESCRIPTION	CCN NAME	RANGE	DEFAULT VALUE*	UNIT	READ/WRITE
1	Refrigerant Pump	REF_PUMP	OFF/ON		OFF/ON	RO
2	Guide Vane2 Output	GV2_OUT	0 TO 20		mA	RO
3	ECO Liquid Bypass Valve	ECBY_VLV	OFF/ON		OFF/ON	RO
4	ECO Isolation VLV	ECON_IV	OFF/ON		OFF/ON	RO
5	Cond Valve (Ref Lube)	COND_CV	OFF/ON		OFF/ON	RO
6	Evap Valve (Ref Lube)	EVAP_CV	OFF/ON		OFF/ON	RO
7	Condenser Drain Valve	COND_DV	OFF/ON		OFF/ON	RO
8	Purge Cond Valve	EVAP_PSV	OFF/ON		OFF/ON	RO
9	Purge Comp Valve	COMP_PSV	OFF/ON		OFF/ON	RO
10	Purge Pumpout Valve	PUMP_PSV	OFF/ON		OFF/ON	RO
11	Purge Drainage Valve	DRASVON	OFF/ON		OFF/ON	RO
12	Purge Regeneration Valve	REG_PSV	OFF/ON		OFF/ON	RO
13	Purge Discharge Valve	DIS_PSV	OFF/ON		OFF/ON	RO
14	Purge Vacuum Pump	PGAPUMP	OFF/ON		OFF/ON	RO
15	Purge Compressor	PG_COMP	OFF/ON		OFF/ON	RO
16	Purge Heater	PG_HEAT	OFF/ON		OFF/ON	RO
17	Purge Idle Drainage VLV	VLV, DRA_IDLE	OFF/ON		OFF/ON	RO
18	Free Cooling Valve	FC_VALVE	OFF/ON		OFF/ON	RO
19	Condenser Charging (Ref Lube)	COND_FCV	OFF/ON		OFF/ON	RO

LEGEND

RO — Read Only

*Default value is shown only if configurable in this table.

APPENDIX A — PIC6 SCREEN AND TABLE STRUCTURE (CONT)

Hydraulic Status

CCN TABLE NAME: HYDRLIC

PIC6 PATH: Main Menu → Hydraulic Status

LINE	PIC6 DESCRIPTION	CCN NAME	RANGE	DEFAULT VALUE*	UNIT	READ/WRITE
1	Condenser Water Pump	CDWP	OFF/ON			RO
2	Condenser Water Flow	CDW_FLOW	NO/YES			RO
3	Cond Water Flow Value	CDW_FV	0 to 10,000		GPM	RO
4	Entering Cond Water Pres	COND_EWP	-6.7 to 420.0		psig	RO
5	Leaving Cond Water Pres	COND_LWP	-6.7 to 420.0		psig	RO
6	Condenser Water Delta P	cdw_pd	-10.0-10.0	0.0	psi	RW
7	Condenser Delta P Offset	cdw_off	-10.0-10.0	0.0	psig	RW
8	Cond Water Pulldown/Min	cdw_pull	-20 to 20.0		°F	RO
9	Chilled Water Pump	CHWP	OFF/ON			RO
10	Chilled Water Flow	CHW_FLOW	NO/YES			RO
11	Chilled Water Flow Value	CHW_FV	-10.0 to 10.0	0.0	GPM	RW
12	Entering Chilled Water P	EVAP_EWP	-6.7 to 420.0		psig	RO
13	Leaving Chilled Water P	EVAP_LWP	-6.7 to 420.0		psig	RO
14	Chilled Water Delta P	chw_pd	-6.7 to 420.0		psig	RO
15	Chilled Delta P Offset	chw_off	-10 to 10.00	0.0	psig	RW
16	Chilled Water Pulldown/Min	chw_pull	-20 to 20.0		°F	RO
17	Chilled Water Flow Input	CHWF_IN	4 to 20		mA	RO
18	Cond Water Flow Input	CDWF_IN	4 to 20		mA	RO
19	Chilled Water Pres Drop	CHW_PDMA	4 to 20		mA	RO
20	Cond Water Pres Drop	CDW_PDMA	4 to 20		mA	RO
21	Evap Water Flow Switch	EVAP_FS	OPEN/CLOSE			
22	Cond Water Flow Switch	COND_FS	OPEN/CLOSE			
23	Tower Fan Relay High	TFR_HI	OFF/ON			RO
24	Tower Fan Relay Low	TFR_LO	OFF/ON			RO
25	Controlled Water DT	ctrlw_dt	-40.0 to 245.0		°F	RO
26	Chilled Water Flow Status 0=Fail or Not Started 1=Success, 2=Verifying	chw_fl_s	0 to 2			RO
27	Cond Water Flow Status 0=Fail or Not Started 1=Success, 2=Verifying	cdw_fl_s	0 to 2			RO
28	Pumpdown/Lockout State	pdown_st	0 to 255			RO

LEGEND

RO — Read Only
RW — Read/Write

*Default value is shown only if configurable in this table.

Run Times

CCN TABLE NAME: RUNTIME

PIC6 PATH: Main Menu → Run Times

LINE	PIC6 DESCRIPTION	CCN NAME	RANGE	DEFAULT VALUE*	UNIT	READ/WRITE
1	Starts in 12 Hours	ST_CNT12	0 to 8			RO
2	Compressor Starts Num	C_STARTS	0 to 99999			RW
3	Comp Running Time	COMP_MIN		0	min	RO
4	Compressor Total Running Hrs	COMP_HRS	0 to 500000.0		hr	RW
5	After Service Hrs	SRV_HRS	0 to 500000.0	0.0	hr	RW
6	Stop to Start Timer	spst_tim	1.0 to 15.0		min	RO
7	Start to Start Timer	stst_tim	4.0 to 45.0		min	RO
8	Oil Lubrication Duration	oilb_dur	1000 to 8000		hr	RO
9	Oil Storage Duration	oils_dur	5000 to 15000		hr	RO
10	Recy Startup in 4 Hours	RCYSTCNT	0 to 6			RO
11	Swift Restarts in 1 Hour	SWIFTCNT	0 to 4			RO
12	Total Pumpout Numbers	PGP_NO				RO
13	Total Pumpout Time	PGP_TM			min	RO
14	Purge Pumpout in 24 Hrs	pgp_tm_d			min	RO
15	Avg Daily Purge in 7 Day	pgp_tm_w			min	RO
16	Controller Uptime	uptime			day-hour-minute	RO
17	Last Reboot Reason	last_rr				RO

LEGEND

RO — Read Only
RW — Read/Write

*Default value is shown only if configurable in this table.
NOTE: The displayed runtime is updated every hour. To avoid the loss of data in case of disruption, the values are backed up.

APPENDIX A — PIC6 SCREEN AND TABLE STRUCTURE (CONT)

Modes

CCN TABLE NAME: MODES

PIC6 PATH: Main Menu → Modes

LINE	PIC6 DESCRIPTION	CCN NAME	RANGE	DEFAULT VALUE*	UNIT	READ/WRITE
1	Normal Shutdown	shut_nor	NO/YES			RO
2	Recycle Shutdown	shut_rcy	NO/YES			RO
3	Alarm Shutdown	shut_alm	NO/YES			RO
4	Recycle Startup	str_rcy	NO/YES			RO
5	Temperature Ramping	tmp_ramp	NO/YES			RO
6	Load Ramping	ld_ramp	NO/YES			RO
7	IGV1 Inhibiting	gv1_inh	NO/YES			RO
8	Ice Building	ice_act	NO/YES			RO
9	Ice Build Terminated	ice_term	NO/YES			RO
10	Ice Build Recy Startup	ice_rcy	NO/YES			RO
11	Ramp Loading	ramp_act	NO/YES			RO
12	Demand Limit	dem_act	NO/YES			RO
13	VFD Rampdown	vfdrpact	NO/YES			RO
14	Demand Limit Inhibit	dem_inh	NO/YES			RO
15	Evaporator Frozen	evapfrze	NO/YES			RO
16	Condenser Frozen	condfrze	NO/YES			RO
17	Recycle Shutdown Done	rcysh_cm	NO/YES			RO
18	NonRecycle Shutdown Done	nrysh_cm	NO/YES			RO
19	In Alarm	alm_act	NO/YES			RO
20	In Override	over_act	NO/YES			RO
21	Purge Active	pg_act	NO/YES			RO
22	Comp 1 Run State Val	cm_stat1			Integer	RO

LEGEND

*Default value is shown only if configurable in this table.

RO — Read Only

Setpoint

CCN TABLE NAME: SETPOINT

PIC6 PATH: Main Menu → Setpoint

LINE	PIC6 DESCRIPTION	CCN NAME	RANGE	DEFAULT VALUE*	UNIT	READ/WRITE
1	Cooling ECW Setpoint	ecw_sp	15.0 to 120.0	60.0	°F	RW
2	Cooling LCW Setpoint	lcw_sp	10.0 to 120.0	45.0	°F	RW
3	Heating ECDW Setpoint	ecdw_sp	63.0 to 150.0	104.0	°F	RW
4	Heating LCDW Setpoint	lcdw_sp	68.0 to 150.0	113.0	°F	RW
5	Ice Build Setpoint	ice_sp	15.0 to 60.0	40.0	°F	RW
6	Base Limit Demand	dem_base	10.0 to 100.0	100.0	%	RW
7	EWT Control Option	EWT_OPT	DISABLE/ENABLE	DISABLE		RW

LEGEND

















RW — Read/Write

*Default value is shown only if configurable in this table.

APPENDIX A — PIC6 SCREEN AND TABLE STRUCTURE (CONT)

Configuration Menu for 19DV

Navigation: MAIN MENU → CONFIGURATION MENU

ICON	DISPLAYED TEXT	ACCESS	ASSOCIATED TABLE	PAGE NO.
	Factory Parameters	Factory	FACTORY	55
	Service Parameters	Service	SERVICE1	55
	Surge Correction	Service	CFGSURGE	56
	Protective Limit	Service	CFGLIMIT	56
	Lab Test Forced	Service	LABONLY	Factory only
	Option	Service	CONF_OPT	57
	Option 2	Service	CONF_OPT2	57
	VFD Parameters	Service	CFGUMVFD	58
	General	User	GEN_CONF	58
	Control Identification	User	CTRL_ID	Info. only
	19DV	Service	CFG_19DV	59
	General VFD	Service	CFGGEVFD	59
	I/O	Service	CONF_IOB	59
	Master Slave	Service	CONF_MS	60
	Temperature Reset	User	RESETCFG	60
	Schedule Menu	User	SCHEDULE	61
	Holiday Menu	User	HOLIDAY	62
	Broadcast Menu	User	BROADCAST	62
	BMS Protocol	Service	CONNECT	63
	AHF	Service	CFGAHF	
	Low Load	Service	LQBP	63

APPENDIX A — PIC6 SCREEN AND TABLE STRUCTURE (CONT)

Factory

CCN TABLE NAME: FACTORY

PIC6 PATH: Main Menu → Configuration Menu → Factory Parameters

LINE	PIC6 DESCRIPTION	CCN NAME	RANGE	DEFAULT VALUE*	UNIT	READ/WRITE
1	Chiller Type 0=19XR6/7, 1=19XR2-5/E/D/V, 2=19DV, 3=19XRF	chil_typ	0 to 3	0		RW
2	VFD/Starter Option 0 = Starter with ISM, 1 = FS VFD with ISM, 2=Carrier 32VS VFD, 3=Rockwell LF2 VFD, 4=EATON VFD, 5=Rockwell Std Tier VFD, 7= Danfoss VFD, 8 = Benshaw Starter	vfd_opt	0 to 8	0		RW
3	Unit Type 0 = Cool Only, 1 = Heat Machine	unit_typ	0 to 1	0		RW
4	Chilled Medium Type	chmedium	WATER/BRINE	WATER		RW
5	Comp Refrig Press 0=44 psi, 1=72 psi	comp_pre	0 to 1	0		RW
6	Country Code	coun_cod	0 to 500	86		RW

Service Parameters

CCN TABLE NAME: SERVICE1

PIC6 PATH: Main Menu → Configuration Menu → Service Parameters

LINE	PIC6 DESCRIPTION	CCN NAME	RANGE	DEFAULT VALUE*	UNIT	READ/WRITE
1	Atmospheric Pressure	atom_pre	8 to 15	14.5	psi	RW
2	GV1 Travel Limit	gv1_lim	30 to 100	80	%	RW
3	GV1 Closure at Startup	gv1stpos	0 to 40	4	%	RW
4	Maximum GV Movement	max_gv	2.0 to 4.0	2.0	%	RW
5	Controlled Fluid DB	ctrl_db	0.5 to 2.0	1.0	°F	RW
6	Derivative EWT Gain	ewtdgain	1.0 to 3.0	2.0		RW
7	Proportional Dec Band	gv1decdb	2.0 to 10.0	6.0		RW
8	Proportional Inc Band	gv1incdb	2.0 to 10.0	6.5		RW
9	Demand Limit At 20 mA	dem_20ma	10 to 100	40	%	RW
10	Demand Limit Prop Band	dem_pdb	3.0 to 15.0	10.0	%	RW
11	Amps or KW Ramp per Min	ldramprt	5 to 20	10	%	RW
12	Temp Ramp Rate per Min	tmramprt	1 to 10	3	°F	RW
13	Recycle Shutdown Delta T	rcysh_dt	0.5 to 4.0	1.0	°F	RW
14	Recycle Restart Delta T	rcyst_dt	2.0 to 10.0	5.0	°F	RW
15	Lub Press Verify Time	oilpvr_t	15 to 300	180	s	RW
16	Water Flow Verify Time	wflow_t	0.5 to 5.0	5.0	min	RW
17	Soft Stop Amps Threshold	st_st_th	40 to 100	70	%	RW
18	Power Calibration Factor	mbb_pfcl	0.5 to 2.0	1.0		RW
19	Enable Excessive Starts	ex_start	No/Yes	No		RW

LEGEND

RW — Read/Write

*Default value is shown only if configurable in this table.

APPENDIX A — PIC6 SCREEN AND TABLE STRUCTURE (CONT)

Surge Correction

CCN TABLE NAME: CFGSURGE

PIC6 PATH: Main Menu → Configuration Menu → Surge Correction

LINE	PIC6 DESCRIPTION	CCN NAME	RANGE	DEFAULT VALUE*	UNIT	READ/WRITE
1	Surge Line Configuration 0=PR, 1=Delta T	sgl_cfg	0 to 1	0		RW
2	IGV1 Pos Configuration 0-Degree, 1=Percentage	gv1c_sel	0 to 1	0		RW
3	Surge Delta Tmax	dt_s_max	0.0 to 150.0	70.0	°F	RW
4	Surge Delta Tmin	dt_s_min	0.0 to 150.0	45.0	°F	RW
5	PR at Full Load Opening	pr_ful	1.0000 to 5.0000	3.0000		RW
6	PR at Min. Opening	pr_min	1.0000 to 5.0000	1.5000		RW
7	IGV1 Minimum Position	gv1_pmin	0 to 100	5	%	RW
8	IGV1 Full Load Position	gv1_pful	0 to 100	100	%	RW
9	Surge Line Offset	sgl_off	1.0 to 3.0	2.0	°F	RW
10	Surge Lower Deadband	sql_hoff	0.5 to 3.0	1.5	°F	RW
11	Surge Upper Deadband	sql_hoff	0.1 to 3.0	1.5	°F	RW
12	Surge Line Shape Factor	sgl_shfh	-1.000 to 0.000	-0.010		RW
13	Surge Line Speed Factor	sgl_spdf	0.00 to 3.00	2.00		RW
14	Surge Delay Time	surg_del	0 to 120	15	sec	RW
15	Surge Time Period	surge_t	7 to 10	8	min	RW
16	Surge Delta Amps %	surge_a	5 to 40	20	%	RW
17	Rampdown Factor	rd_fact	0 to 1	0.1		RW
18	GV1 Close Step Surge	gvstp_sg	1.0 to 3.0	2.0	%	RW
19	VFD Speed Step Surge	vfdstpsg	1.0 to 5.0	1.5	%	RW
20	EC Valve Step Surge	hbpstsg	1.0 to 10.0	4.0	%	RW
21	Surge Profile Offset	sgl_pro	0.0 to 5.0	0.0	^F	RW
22	High Efficiency Mode	high_eff	DISABLE/ENABLE	DISABLE		RW
23	GV Jumpover Option	gv_skip	DISABLE/ENABLE	DISABLE		RW

LEGEND

*Default value is shown only if configurable in this table.

RW — Read/Write

Protective Limit

CCN TABLE NAME: CFGLIMIT

PIC6 PATH: Main Menu → Configuration Menu → Protective Limit

LINE	PIC6 DESCRIPTION	CCN NAME	RANGE	DEFAULT VALUE*	UNIT	READ/WRITE
1	Evap Approach Alert	evap_al	0.5 to 15	5	°F	RW
2	Cond Approach Alert	cond_al	0.5 to 15	6	°F	RW
3	Evap Override Delta T	ert_ovdt	2 to 5	3	°F	RW
4	Evap Refrig Trippoint	ert_trip	0 to 40	33	°F	RW
5	Hi Evap Press Override DV	ep_ovdv	20 to 56	55	psi	RW
6	Hi Evap Press Cutout DV	ep_cut	59 to 60.3	59	psi	RW
7	Cond Pre Override DV 44	cpov_dl	18 to 57.3	27	psi	RW
8	Cond Pre Cutout DV 44	cpcut_dl	30 to 60.3	30	psi	RW
9	Cond Pre Override DV 72	cpov_dh	20.0 to 56.0	55.0	psi	RW
10	Cond Pre Cutout DV 72	cpcut_dh	59.0 to 60.3	59.0	psi	RW
11	Condenser Freeze Point	tb_trip2	210 to 220	220	°F	RW
12	Comp Discharge Alert	dgt_alrt	125 to 200	200	°F	RW
13	Comp Motor Temp Override	mt_over	150 to 200	200	°F	RW
14	Comp Bearing Alert	tb_alt3	90.0 to 120.0	104.0	°F	RW
15	Comp Bearing Trip	tb_trip3	121.0 to 150.0	122.0	°F	RW
16	Minimum Brine LWT	bri_min	10 to 34	34	°F	RW
17	Heating LWT Protect Set	lwtp_sp	41 to 50	42.8	°F	RW
18	Evap Flow Delta P Cutout	evap_cut	0.5 to 50	5	psig	RW
19	Cond Flow Delta P Cutout	cond_cut	0.5 to 50	5	psig	RW
20	Cond Hi Flow DP Limit	cond_val	0.5 to 50	50	psig	RW
21	Cond Hi Flow Alarm	cond_alm	DISABLE/ENABLE	DISABLE		RW
22	Inverter Temp Override	inv_ov	100 to 400	200	°F	RW

LEGEND

RW — Read/Write

*Default value is shown only if configurable in this table.

APPENDIX A — PIC6 SCREEN AND TABLE STRUCTURE (CONT)

Option

CCN TABLE NAME: CONF_OPT

PIC6 PATH: Main Menu → Configuration Menu → Option

LINE	PIC6 DESCRIPTION	CCN NAME	RANGE	DEFAULT VALUE*	UNIT	READ/WRITE
1	Auto Restart Option	astart	DISABLE/ENABLE	DISABLE		RW
2	Swift Restart Option	swistart	Disable/Enable	Disable		RW
3	Gas Torque Factor	gt_fact	0.25 to 3	1		RW
4	Guide Vane/SRD Factor	gv_srd_f	0.7 to 1.2	0.95		RW
5	Power Recovery Timeout	pd_tcfg	0 to 60	15	min	RW
6	Common Sensor Option	commsens	DISABLE/ENABLE	DISABLE		RW
7	EC/HG Valve Option 0 = No, 1 = Cont 2 = On/Off, 3 = 4-20 mA	hgbp_opt	0 to 3	0		RW
8	EC/HG Selection 0 = Disable, 1 = Surge 2 = Low Load, 3 = Comb	hgbp_sel	0 to 3	0		RW
9	EC/HG VLV Open IGV1 Position	hpop_gv1	0.5 to 10	5.0	%	RW
10	EC/HG VLV Close IGV1 Position	hgcl_gv1	1.5 to 20	10.0	%	RW
11	EC/HG VLV Off DT for Low Load	hgb_toff	0.5 to 10.0	4.0	^F	RW
12	EC/HG VLV On DT for Low Load	hgb_ton	0.5 to 10.0	2.0	^F	RW
13	EC/HG VLV Low Load DB	hgbp_ldb	0.5 to 2.0	1.0	^F	RW
14	Head Pres Valve Option	hdpv_opt	DISABLE/ENABLE	DISABLE		RW
15	Head Pres Delta P 0%	hdp_0	0 to 85.0	25.0	psid	RW
16	Head Pres Delta P 100%	hdp_100	0 to 85.0	50.0	psid	RW
17	Head Pressure Min Output	hdpv_min	0.0 to 100.0	0.0	%	RW
18	Head Pressure Deadband	hdpv_db	0 to 10	1	°F	RW
19	Tower Fan High set point	tfh_sp	55 to 105	75		RW
20	Refrigerant Leak Option	leak_en	DISABLE/ENABLE	DISABLE		RW
21	Refrig Leakage Alarm mA	exv_opt	4 to 20	20		RW
22	Customer Alert Option	cusa_opt	DISABLE/ENABLE	DISABLE		RW
23	Ice Build Option	ice_opt	DISABLE/ENABLE	DISABLE		RW
24	Ice Build Recycle	ice_recy	DISABLE/ENABLE	DISABLE		RW
25	Ice Build Termin Source 0 = Temp, 1 = Contact, 2 = Both	ice_term	0 to 2	0		RW
26	Evap Liquid Temp Opt	evap_ref	DISABLE/ENABLE	ENABLE		RW
27	Evap App Calc Selection Sat Temp = 0, Ref Temp = 1	evap_ref	0/1	1		RW

Option 2

CCN TABLE NAME: CONFOPT2

PIC6 PATH: Main Menu → Configuration Menu → Option 2

LINE	PIC6 DESCRIPTION	CCN NAME	RANGE	DEFAULT VALUE*	UNIT	READ/WRITE
1	IOB4 Option	iob4_opt	YES/NO	NO		RW
2	Free Cooling Option		YES/NO	NO		RW
3	Water Pressure Option (0=No, 1= WTR Flow PD TRD, 2=WTR Flow PD TRM)	wp_opt	0-2	0		
	Water Pres Drop @ 20 mA	wpd_20ma	10-40	10	psi	RW (if wp_opt = 2)
4	Water Flow Measurement (0=No, 1=WTR Flow MTR, 2=WTR Flow PD)	wfm_opt	0-2	0		
	Water Flow at 4mA	flow4ma	0-12,000	0	GPM	RW (if wfm_opt=1)
	Water Flow at 20mA	flow20ma	0-12,000	0	GPM	RW (if wfm_opt=1)
	Evap Flow Rate Baseline	chwf_bas	0-9,000	0	GPM	RW (if wfm_opt=2)
	Evap Pres Drop Baseline	evpd_bas	0-20	0	PSI	RW (if wfm_opt=2)
	Cond Flow Rate Baseline	cdwf_bas	0-9,000	0	GPM	RW (if wfm_opt=2)
	Cond Flow Rate Baseline	cdpd_bas	0-20	0	PSI	RW (if wfm_opt=2)
5	Water Flow Determination (0=Sat Temp, 1=Flow Switch, 2=WTR Flow PD)	fs_opt	0-2	0		RW
6	Marine Option	mm_opt	Disable/Enable	Disable		RW

LEGEND

RW — Read/Write

*Default value is shown only if configurable in this table.

APPENDIX A — PIC6 SCREEN AND TABLE STRUCTURE (CONT)

VFD Parameters

CCN TABLE NAME: CFGUMVFD

PIC6 PATH: Main Menu → Configuration Menu → VFD Parameters

LINE	PIC6 DESCRIPTION	CCN NAME	RANGE	DEFAULT VALUE*	UNIT	READ/WRITE
1	Compressor Speed 100%	comp_hz	47 to 110	50	Hz	RW
2	Rated Line Voltage	rlv_i	200-13800	460	V	RW
3	Motor Nameplate Current	rla	10 to 1500	200	AMPS	RW
4	Motor Rated Load Current	rla_load	10 to 1500	200	AMPS	RW
5	Motor Nameplate Voltage	rlv	200 to 13800	460	Volts	RW
6	Motor Nameplate KW	rlkw	0 to 5600	1500	KW	RW
7	Skip Frequency 1	skipfrq1	0.0 to 102.0	102	Hz	RW
8	Skip Frequency 2	skipfrq2	0.0 to 102.0	102	Hz	RW
9	Skip Frequency 3	skipfrq3	0.0 to 102.0	102	Hz	RW
10	Skip Frequency Band	skipband	0.0 to 102.0	0	Hz	RW
11	Increase Ramp Time	ramp_inc	5 to 60	30	sec	RW
12	Decrease Ramp Time	ramp_dec	5 to 60	30	sec	RW
13	Line Voltage Imbalance%	lvim_th	1 to 10	10	%	RW
14	Line Volt Imbalance Time	lvim_per	1 to 10	10	sec	RW
15	Line Current Imbalance%	lcim_th	5 to 40	40	%	RW
16	Line Current Imbal Time	lcim_per	1 to 10	10	sec	RW
17	Motor Current Imbalance%	mcim_th	5 to 40	40	%	RW
18	Motor Current Imbal Time	mcim_per	1 to 10	10	sec	RW
19	Single Cycle Dropout	scycd_en	0 to 1	0		RW
20	PWM Switch Frequency 0=2KHZ, 1=4KHZ	pwm_freq	0 to 1	0		RW
21	Communication Timeout	com_tout	0 to 60	10	sec	RW

General

CCN TABLE NAME: GEN_CONF

PIC6 PATH: Main Menu → Configuration Menu → General

LINE	PIC6 DESCRIPTION	CCN NAME	RANGE	DEFAULT VALUE*	UNIT	READ/WRITE
1	Stop to Start Delay	min_off	1 to 15	2	min	RW
2	Start to Start Delay	strt_dly	4 to 45	15	min	RW
3	Demand Limit Type 0 = Base Demand, 1 = 4 to 20 mA	dem_sel	0 to 1	0		RW
4	Pulldown Ramp Type 0 = Temp, 1 = Load	ramp_slct	0 to 1	1		RW
5	Demand Limit Source 0 = amps, 1 = kW	DEM_SLCT	0 to 1	0		RW

LEGEND

RW — Read/Write

*Default value is shown only if configurable in this table.

APPENDIX A — PIC6 SCREEN AND TABLE STRUCTURE (CONT)

19DV

CCN TABLE NAME: CFG_19DV

PIC6 PATH: Main Menu → Configuration Menu → 19DV

LINE	PIC6 DESCRIPTION	CCN NAME	RANGE	DEFAULT VALUE*	UNIT	READ/WRITE
1	Pressure Sensor Option (0=Tianmo, 1=Texas, 2=Sensata)	sen_opt	0 to 2	0		RW
2	Purge System Option	pg_opt	DISABLE/ENABLE	DISABLE		RW
3	Purge Active Temp SP	pgt_set	30 to 300	65	°F	RW
4	Purge On Idle Option	pgon_opt	DISABLE/ENABLE	DISABLE		RW
5	Purge Regen Lasting Time	reg_tim	0 to 65535	120	min	RW
6	Purge Discharge Temp	dis_temp	-10000000 to 10000000	8.0	°F	RW
7	Purge Drainage Temp	dra_temp	-10000000 to 10000000	9.0	°F	RW
8	Purge Discharge Time	dis_time	0 to 65535	5	sec	RW
9	PG Discharge Delay Time	dly_time	0 to 65535	30	sec	RW
10	Daily PG Pumpout Limit	pgpumpm	20 to 200	50	min	RW
11	Motor Pole Pair Single=1, Double=2		1 to 2	1		RW
12	IGV2 Travel Limit	gv2_lim	0 to 100	96	%	RW
13	IGV2 Minimum Degree	gv2_dmin	0 to 20	2.0		RW
14	IGV2 Full Load Open Deg	gv2_dfw	10 to 100	90.0		RW
15	IGV2 Actuator Max Deg	gv2_dmax	90 to 120	94.0		RW
16	IGV2 Deg @IGV1 20 Deg	gv2_d20		28.1		RW
17	IGV2 Deg @IGV1 30 Deg	gv2_d30		37.2		RW
18	IGV2 Deg @IGV1 50 Deg	gv2_d50		71.6		RW
19	Comp Based Speed Hz	vfd_ratf	10 to 200	80.5	Hz	RW
20	4-valve Lube (Legay DV4)	lega_lub	DISABLE/ENABLE	DISABLE		RW
21	Pre Lube From Colder HX	opt_7	DISABLE/ENABLE	DISABLE		RW

LEGEND

*Default value is shown only if configurable in this table.

RW — Read/Write

General VFD

CCN TABLE NAME: CFGGEVFD

PIC6 PATH: Main Menu → Configuration Menu → General VFD

LINE	PIC6 DESCRIPTION	CCN NAME	RANGE	DEFAULT VALUE*	UNIT	READ/WRITE
1	VFD Gain	vfd_gain	0.10 to 1.50	0.75		RW
2	VFD Max Speed Per	vfd_max	90.0 to 110.0	100.0	%	RW
3	VFD Min Speed Per	vfd_min	65.0 to 100.0	70.0	%	RW
4	VFD Start Speed Per	vfd_str	65.0 to 100.0	100.0	%	RW
5	VFD Current Limit	vfdculm	0.0 to 99999.0	250	amp	RW

LEGEND

*Default value is shown only if configurable in this table.

RW — Read/Write

IOB

CCN TABLE NAME: CONF_IOB

PIC6 PATH: Main Menu → Configuration Menu → IOB

LINE	PIC6 DESCRIPTION	CCN NAME	RANGE	DEFAULT VALUE*	UNIT	READ/WRITE
1	ECW Sensor Type		0 to 6	4		RW
2	LCW Sensor Type		0 to 6	4		RW
3	ECDW Sensor Type		0 to 6	4		RW
4	LCDW Sensor Type		0 to 6	4		RW
5	MTRW1 Sensor Type		0 to 6	4		RW
6	Ref Leak Sensor Type		0 to 6	2		RW
7	ISM Input Enable		DISABLE/ENABLE	DISABLE		RW

NOTE: 0=Disable, 1=V, 2=mA, 3= 10K thermistor, 4=5K thermistor, 5=Resistance, 6=RTD

APPENDIX A — PIC6 SCREEN AND TABLE STRUCTURE (CONT)

Master Slave

CCN TABLE NAME: CONF_MS

PIC6 PATH: Main Menu → Configuration Menu → Master Slave

LINE	PIC6 DESCRIPTION	CCN NAME	RANGE	DEFAULT VALUE*	UNIT	READ/WRITE
1	Slave Address	slv_addr	1 to 236	2		RW
2	Master/Slave Select 0=Disable, 1=Master, 2=Slave	mst_sel	0 to 2	0		RW
3	Chiller Connection Type 0=Parallel, 1=Series	ms_type	0 to 1	0		RW
4	Middle Sensor Option	mids_opt	YES/NO	YES		RW
5	Master Lead/Lag Select 0=Lead change to Lag Once Failed 1=Runtime Balance	lead_sel	0 to 1	0		RW
6	Series Counter Flow	serct_fl	YES/NO	NO		RW
7	Take Over on Comm Loss	toocl	0 to 1	0		RW
8	Master per Capacity†	ms_per	25 to 75	50	%	RW
9	LAG Shutdown Threshold	lag_shut	25 to 75	50	%	RW
10	Prestart Fault Time	pref_tim	2 to 30	5	min	RW
11	Lead Unload Threshold		50 to 100	100	%	RW
12	Lead/Lag Balance Delta	ll_bal_d	40 to 400	168	hr	RW
13	Lag Start Time	lstr_tim	2 to 30	10	min	RW
14	Lag Stop Time	lstp_tim	2 to 30	10	min	RW
15	Lead Pulldown Time	lead_pul	0 to 60	0	min	RW
16	Lag Minimum Run Time	lag_mini	0 to 150	0	min	RW
17	Lag Run Delta T	lagrundt	0 to 10.0	3.0	^F	RW
18	Lag Off Delta T	lagoffdt	0 to 10.0	1.8	^F	RW

LEGEND

RW — Read/Write

* Default value is shown only if configurable in this table.

† Master % Capacity = master capacity*100% / (master capacity + slave capacity) and Slave % Capacity = 100%-Master % Capacity

Temperature Reset

CCN TABLE NAME: RESETCFG

PIC6 PATH: Main Menu → Configuration Menu → Temperature Reset

LINE	PIC6 DESCRIPTION	CCN NAME	RANGE	DEFAULT VALUE*	UNIT	READ/WRITE
1	Temp Reset Type 0 = No, 1 = 4 to 20 mA 2 = Remote Temp, 3 = Water DT [delta temperature]	res_sel	0 to 3	0		RW
2	Degrees Reset At 20 mA	der_20ma	-30.0 to 30.0	10.0	°F	RW
3	Maximum Deg Temp Reset	deg_rset	-30.0 to 30.0	10.0	°F	RW
4	Remote Temp Full Reset	remtm_fu	-40.0 to 245.0	65.0	°F	RW
5	Remote Temp No Reset	remtm_no	-40.0 to 245.0	85.0	°F	RW
6	Deg Reset Water DT Full	drwdt_fu	-30.0 to 30.0	10.0	°F	RW
7	Controlled DT Full Reset	ctldt_fu	0.0 to 15.0	0.0	°F	RW
8	Controlled DT No Reset	ctldt_no	0.0 to 15.0	10.0	°F	RW

LEGEND

RW — Read/Write

*Default value is shown only if configurable in this table.

APPENDIX A — PIC6 SCREEN AND TABLE STRUCTURE (CONT)

Schedule Menu

Navigation: MAIN MENU → CONFIGURATION MENU → SCHEDULE MENU

ICON	DISPLAYED TEXT	ACCESS	ASSOCIATED TABLE
	Local Schedule	User	
	Ice Build Schedule	User	
	Network Schedule	User	

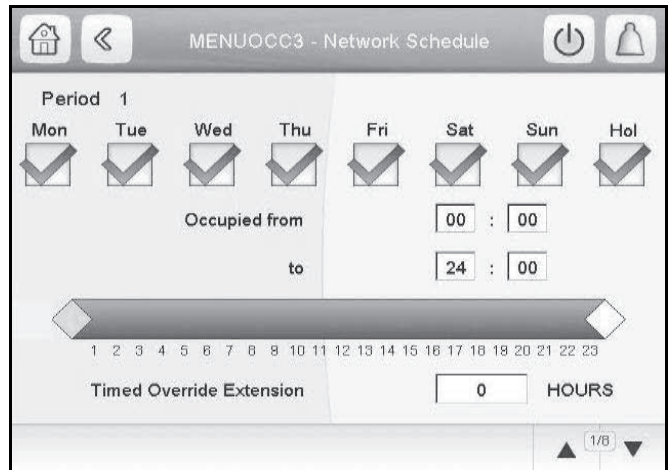
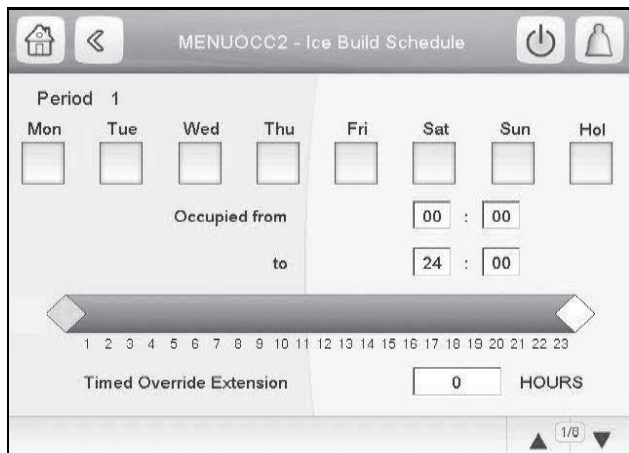
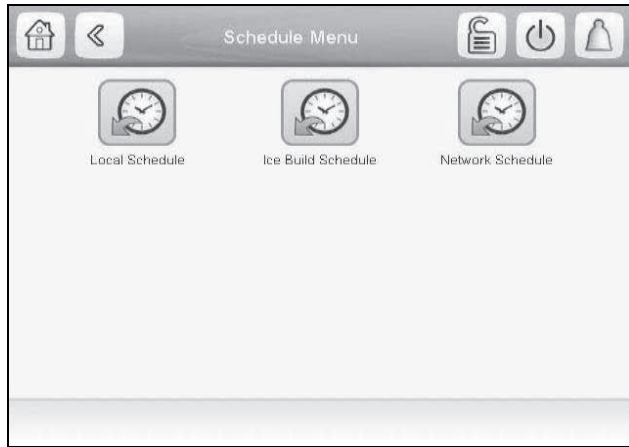

Fig. B — Schedule Menu and Submenus

APPENDIX A — PIC6 SCREEN AND TABLE STRUCTURE (CONT)

Holiday Menu

Navigation: MAIN MENU → CONFIGURATION MENU → HOLIDAY MENU

The Holiday Menu has 16 submenus (HOLDY-01 to HOLDY_16), so it is possible to set 16 different holiday periods. For more information about holiday periods, see the Time Schedule section on page 23. Figure C below shows the Holiday Menu and a sample submenu.

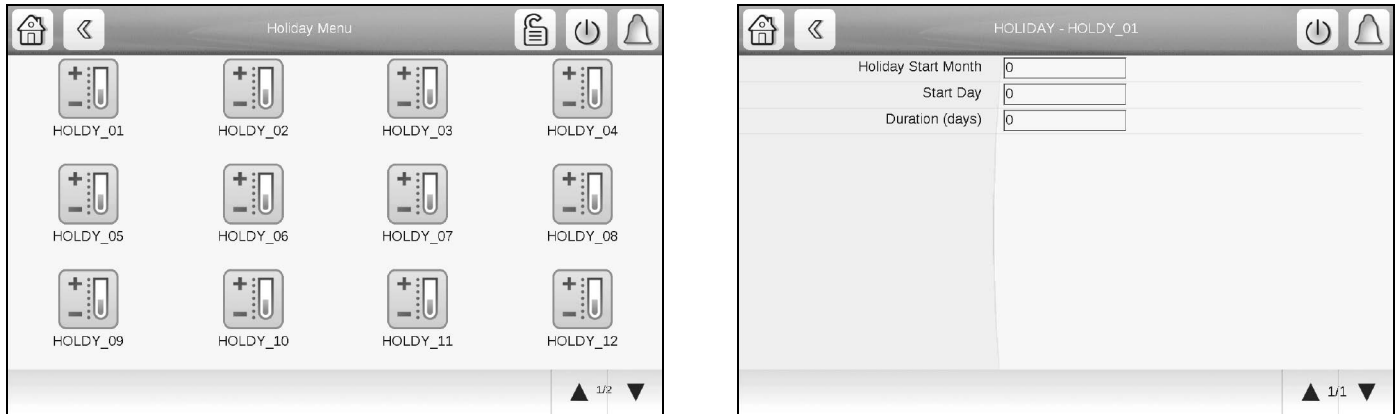

**Fig. C — Holiday Menu and Submenu
Broadcast Menu**

Navigation: MAIN MENU → CONFIGURATION MENU → BROADCAST MENU



Fig. D — Broadcast Menu

APPENDIX A — PIC6 SCREEN AND TABLE STRUCTURE (CONT)

BMS Protocol

CCN TABLE NAME: CONNECT

PIC6 PATH: Main Menu → Configuration Menu → BMS Protocol

LINE	PIC6 DESCRIPTION	CCN NAME	RANGE	DEFAULT VALUE*	UNIT	READ/WRITE
1	Port J8 Option 0=None, 1=BACnet MS/TP, 2=Modbus RTU	j8_opt	0 to 2	0		RW
Modbus Configuration						
2	Modbus TCP Enable	mip_opt	Disable/Enable	Disable		RW
3	Modbus TCP Port Number	port_nbr	0 to 1024	502		RW
4	Modbus Server UID	ser_UID	1 to 255	1		RW
5	Modbus Metric Unit	metric	No/Yes	No		RW
6	Modbus RTU Parity Option 0=No, 1=Odd, 2=Even, 3=Low, 4=High	parity	0 to 4	0		RW
7	Modbus RTU Stop Bit 1= 1 Bit, 2= 2 Bits	stop_bit	1 to 2	2		RW
8	Modbus RTU Baudrate 0=9600, 1=19200, 2=38400	baudrate	0 to 2	0		RW
9	Modbus Litte Endian	swap_b	No/Yes	No		RW
10	Modbus Real Type	real_typ	No/Yes	No		RW
BACnet Configuration						
11	BACnet/IP Enable	bacena	Disable/Enable	Disable		RW
12	BACnet Metric Unit	bacunit	No/Yes	No		RW
13	BACnet Network	network	1 to 9999	1600		RW
14	BACnet Identifier	bac_id	0 to 9999999	1600001		RW
15	BACnet Schedule Enable	bacschen	Disable/Enable	Disable		RW
16	MS/TP Mac address	mstpaddr	1 to 127	1		RW
17	MS/TP Baud rate 0=9600, 1=19200, 2=38400, 3=57600, 4=76800, 5=115200	mstpbaud	0 to 5	2		RW
18	MS/TP Max Master	maxmastr	0 to 127	3		RW
19	MS/TP Max Info Frames	maxinfof	1 to 255	5		RW

*Default value is shown only if configurable in this table.

Low Load

CCN TABLE NAME: CONNECT

PIC6 PATH: Main Menu → Configuration Menu → Low Load

LINE	PIC6 DESCRIPTION	CCN NAME	RANGE	DEFAULT VALUE*	UNIT	READ/WRITE
1	ECO LBP VLV Option	lqby_opt	DISABLE/ENABLE	DISABLE		RW
2	ECO LBP VLV Temp Diff	tempdiff	15-35	25		RW
3	ECO LBP VLV off DSH	lbp_dsh	0-6	3.6		RW
4	ECO LBP VLV Temp Band	lqby_lmt	1-10	3		RW
5	ECO LBP VLV Evap Appro	evap_app	0-20	5		RW
6	Dynamic Demand Limit	lqbp_opt	DISABLE/ENABLE	DISABLE		RW
7	Ignore DDL time	lgn_ddl	0 to 60	30	min	RW
8	LCW at Selection Point	sel_lcw	32 to 86	45		RW
9	LCDW at Selection Point	sel_lcdw	59 to 113	90		RW
10	100% Lift Demand Limit	full_dem	0 to 100	100	%	RW
11	Middle Lift percent	mid_lift	40 to 80	60	%	RW
12	Middle Lift Demand Limit	mid_dem	0 to 100	80	%	RW
13	20% Lift Demand Limit	low_dem	0 to 100	45	%	RW

*Default value is shown only if configurable in this table.

APPENDIX A — PIC6 SCREEN AND TABLE STRUCTURE (CONT)

Date/Time Configuration

Navigation: MAIN MENU → SYSTEM CONFIGURATION MENU → DATE/TIME CONFIGURATION

Date/Time Configuration	
Current Date	01/23/2019
Current Time	11:42 PM
Config Date	01/23/2019
Config Time	11:42 PM
NTP Server	0
Frequency of Sync	1.00
Time Sync/User Choice	?
Status	response after 1 seconds

Fig. E — Date/Time Configuration Menu

Quick Test Menu

Navigation: MAIN MENU → QUICK TEST

Quick Test

CCN TABLE NAME: QCK_TEST

PIC6 PATH: Main Menu → Quick Test

LINE	PIC6 DESCRIPTION	CCN NAME	RANGE	DEFAULT VALUE*	UNIT	READ/WRITE
1	Quick Test Enable	QCK_TEST	0 to 1	0		RW
2	Oil/Ref Pump	Q_OILP	0 to 1	0		RW
3	Oil/Ref Pres Test Passed	OP_PASS	0 to 1			RO
4	Oil/Ref Pump Delta Press	OIL_PDQ			psi	RO
5	HPR VLV Position	Q_HDP	0 to 100	0	%	RW
6	Chiller Status (Analog)	Q_CHST	4 to 20	4	mA	RW
7	Chiller Status (Discrete)	Q_RUN_ST	OFF/ON	OFF		RW
8	Guide Vane 1 Pos	Q_GV1POS	0 to 100	0	%	RW
9	Guide Vane 1 Actual Pos	Q_GV1ACT			%	RO
10	EC/HC Valve Tested Pos	Q_HGBP_T	0 to 100	0	%	RW
11	Alarm Output	Q_ALM	OFF/ON	OFF		RW
12	Alert Output	Q_ALE	OFF/ON	OFF		RW
13	Condenser Water Pump	Q_CDWP	OFF/ON	OFF		RW
14	Condenser Water Flow	CDW_FLOW	YES/NO			RO
15	Chilled Water Pump	Q_CHWP	OFF/ON	OFF		RW
16	Chilled Water Flow	CHW_FLOW	YES/NO			RO
17	Condenser Water Delta T	CDW_DT	-22.2 to 136.1		F	RO
18	Chilled Water Delta T	CHW_DT	-22.2 to 136.1		F	RO
19	Liquid Level EXV	Q_LLCEXV	0 to 100	0	%	RW
20	Free Cooling	Q_FCMODE	OFF/ON	OFF		RW
21	Low Speed Tower Fan	Q_LOWFAN	OFF/ON	OFF		RW
22	High Speed Tower Fan	Q_HIFAN	OFF/ON	OFF		RW
23	Shunt Trip Relay	Q_TRIPR	OFF/ON	OFF		RW

LEGEND

RO — Read Only
RW — Read/Write

*Default value is shown only if configurable in this table.

APPENDIX A — PIC6 SCREEN AND TABLE STRUCTURE (CONT)

Quick Test Menu

Navigation: MAIN MENU → 19DV QUICK TEST

19DV Quick Test

CCN TABLE NAME: QCK_DV

PIC6 PATH: Main Menu → 19DV Quick Test

LINE	PIC6 DESCRIPTION	CCN NAME	RANGE	DEFAULT VALUE*	UNIT	READ/WRITE
1	Quick Test Enable	QCK_TEST	0 to 1	0		RW
2	Guide Vane 2 Tested Pos	Q_GV2POS	0 to 100	0	%	RW
3	Cond CV (DV Lube Sled)	Q_CONDSV	OFF/ON	OFF		RW
4	Evap CV (DV Lube Sled)	Q_EVAPSV	OFF/ON	OFF		RW
5	Cond Drain CV	Q_PRELUB	OFF/ON	OFF		RW
6	Purge Cond SV	Q_CDPSV	OFF/ON	OFF		RW
7	Purge Comp SV	Q_CMPSV	OFF/ON	OFF		RW
8	Pumpout SV	Q_POPSV	OFF/ON	OFF		RW
9	Drainage SV	Q_DROPR	OFF/ON	OFF		RW
10	Purge Rege SV	Q_RGPSV	OFF/ON	OFF		RW
11	Purge Discharge SV	Q_DCPSV	OFF/ON	OFF		RW
12	Purge Vacuum Vacuum Pump	Q_PVPSV	OFF/ON	OFF		RW
13	Purge Compressor	Q_PCPSV	OFF/ON	OFF		RW
14	Purge Heater	Q_PHPSV	OFF/ON	OFF		RW
15	Purge Idle Drain SV	Q_IDLE	OFF/ON	OFF		RW
16	ECO Liquid Bypass VLV	Q_ECBP	OFF/ON	OFF		RW
17	ECO Isolation VLV	Q_ECONIV	OFF/ON	ON		RW
18	Condenser Charging VLV	Q_CONDCV	OFF/ON	OFF		RW
19	Free Cooling VLV	Q_FCMODE	OFF/ON	OFF		RW
20	Motor Rotation Check	Q_MRC	DISABLE/ENABLE	DISABLE		RW
21	Check State IDLE=0, PreLub=1, Rotat=2, PosLub=3, End=4	Q_MRC_ST	0 to 4			RO

LEGEND

RO — Read Only
RW — Read/Write

*Default value is shown only if configurable in this table.

APPENDIX A — PIC6 SCREEN AND TABLE STRUCTURE (CONT)

Quick Calibration Menu

Navigation: MAIN MENU → QUICK Calibration

Quick Calibration

CCN TABLE NAME: QCK_CALI

PIC6 PATH: Main Menu → Quick calibration

LINE	PIC6 DESCRIPTION	CCN NAME	RANGE	DEFAULT VALUE*	UNIT	READ/WRITE
1	Quick Test Enable	QCK_TEST	DISABLE/ENABLE	DISABLE		RW
2	GV1 Calibration Enable	GV1_CAL	DISABLE/ENABLE	DISABLE		RW
3	GV1 Calibration Status					
4	0 = no calibration/Failure, 1= in progress, 2= completed	GV1_STAT				RO
5	Guide Vane 1 Actual Ohms	GV1_OHM	0 to 12000		Ohms	RO
6	Guide Vane 1 Ohms 100%	GV1_MAXO	0 to 12000		Ohms	RO
7	Guide Vane 1 Ohms 0%	GV1_MINO	0 to 12000		Ohms	RO
8	Guide Vane 1 Actual mA	GV1_MAF	0 to 20.80		mA	RO
9	Guide Vane 1 mA 100%	GV1_MAXA	0 to 20.80		mA	RO
10	Guide Vane 1 mA 0%	GV1_MINA	0 to 20.80		mA	RO
11	GV2 Calibration Enable	GV2_CAL	DISABLE/ENABLE	DISABLE		RW
12	GV2 Calibration Status					
13	0 = no calibration/Failure, 1= in progress, 2= completed	GV2_STAT				RO
14	Guide Vane 2 Actual mA	GV2_MAF	0 to 20.80		mA	RO
15	Guide Vane 2 mA 100%	GV2_MAXA	0 to 20.80		mA	RO
16	Guide Vane 2 mA 0%	GV2_MINA	0 to 20.80		mA	RO
17	EC Valve Calib Enable	HGBP_CAL	DISABLE/ENABLE	DISABLE		RW
18	EC Valve Calib Status					
19	0 = no calibration/Failure, 1= in progress, 2= completed	HGBP_ST				RO
20	EC Valve Actual mA	HGBP_AMA	0 to 20.80		mA	RO
21	EC Valve mA 100%	HBP_MAXA	0 to 20.80		mA	RO
22	EC Valve mA 0%	HBP_MINA	0 to 20.80		mA	RO
23	Ref Lub 1st Test, Disable	RL1TEST				RO
24	Ref Lub 1st Test Time	RL1TIME			min	RO
25	Ref Lub 1st Test Status	RL1STAT				RO

LEGEND

RO — Read Only
RW — Read/Write

*Default value is shown only if configurable in this table.

APPENDIX A — PIC6 SCREEN AND TABLE STRUCTURE (CONT)

Maintenance Menu

Navigation: MAIN MENU → MAINTENANCE MENU

ICON	DISPLAYED TEXT*	ACCESS	ASSOCIATED TABLE	PAGE NO.
	Capacity Control	Service	CAPACTRL	68
	Override Control	Service	OVERRIDE	68
	Surge Correction	Service	MAISURGE	69
	Maintenance VFD Config	Service	VFD_MCFG	69
	Swift Restart	Service	MAISWRST	70
	Power Line Parameters	Service	POWER_I	70
	ISM or VFD History	Service	MAIISMH	70
	Power Load Parameters	Service	POWER_O	71
	VFD Status	Service	VFD_STAT	72
	Maintenance Others	Service	MAIOTHER	73
	Maintenance IOB	Service	MAIOB	74
	Board Software PN	Service	MAI_BDSN	74
	Pressure Sensor Calib	Service	PRES_CAL	75
	Temp Sensor Calib	Service	TEMP_CAL	78
	System Status	Service	SYS_STAT	79
	System Information	Service	N/A	N/A
	AHFStatus	Service	N/A	N/A

*Displayed text depends on the selected language (default is English).

APPENDIX A — PIC6 SCREEN AND TABLE STRUCTURE (CONT)

Capacity Control

CCN TABLE NAME: CAPACTRL

PIC6 PATH: Main Menu → Maintenance Menu → Capacity Control

LINE	PIC6 DESCRIPTION	CCN NAME	RANGE	DEFAULT VALUE*	UNIT	READ/WRITE
1	Total Error + Resets	tot_err			°F	RO
2	Control Point Error	ctrl_err			°F	RO
3	Controlled Water Temp	ctrl_wt			°F	RO
4	Control Point	ctrl_pnt			°F	RO
5	Actual Set Point	setpoint			°F	RO
6	Entering Water Change DT	ewt_dt			°F	RO
7	Enter Water Temp Reset	ewt_res			°F	RO
8	Leaving Water Temp Reset	lwt_res			°F	RO
9	Discharge Gas Temp Reset	dgt_res			°F	RO
10	Capacity Delta	capa_dlt	0 to 100		%	RO
11	Target GV1 Pos	gv1_tgt			%	RO
12	GV1 Pos Change Delta	gv1delta			%	RO
13	Target GV2 Position	gv2_tgt	0 to 2		%	RO
14	GV1 Change Flag (0=Stop, 1=Change, 2=Cont)	gv1_chg	0 to 2			RO
15	VFD Speed Change Flag 0 = Stop, 1 = Change, 2 = Cont	vfd_chg	0 to 2			RO
16	Target VFD Speed Percent	vfd_tgt			%	RO
17	VFD Speed Change Delta	vfd_dlt				RO
18	20 ECO DMP VLV Change Delta					
19	ECO DMP VLV Target Per	dmp_tp			%	RO
20	Damper Change Delta %	dmp_dlt	0 to 100		%	RO
21	EC/HG VLV Target Percent	hgbp_tp	0 to 100		%	RO
22	Capacity Inhibit Flag	cap_inh	NO/YES			RO
23	Capacity Decrease Flag	cap_dec	NO/YES			RO
24	Condenser Water Delta T	cdw_dt			°F	RO
25	Chilled Water Delta T	chw_dt			°F	RO
26	Pulldown Set Point	pull_set			%	RO
27	Demand Limit Inh Clamp	deinhclm			%	RO
28	Ramping Demand Limit Val	ramp_dem	NO/YES			RO
29	Compressor is Running	comp_run	NO/YES			RO
30	Comp1 Run State Val	cm_stat1	0 to 14		%	RO

LEGEND

*Default value is shown only if configurable in this table.

RO — Read Only

Override Control

CCN TABLE NAME: OVERRIDE

PIC6 PATH: Main Menu → Maintenance Menu → Override Control

LINE	PIC6 DESCRIPTION	CCN NAME	RANGE	DEFAULT VALUE*	UNIT	READ/WRITE
1	Capacity Inhibit	cap_inho	NO/YES			RO
2	Capacity Decrease	cap_deco	NO/YES			RO
3	High Condenser Pressure	cpov_fl	NO/YES			RO
4	Low Discharge Superheat	dshov_fl	NO/YES			RO
5	Low Suction Sat Temp	sstov_fl	NO/YES			RO
6	High Motor Temp	mtov_fl	NO/YES			RO
7	High Bearing Temp	tbov_fl	NO/YES			RO
8	Low Source Temp	lstov_fl	NO/YES			RO
9	High Discharge Temp	dgtov_fl	NO/YES			RO
10	High Motor Current	ampov_fl	NO/YES			RO
11	Required DSH	dsh_req			^F	RO
12	Evap Sat Override Temp	ert_over			°F	RO
13	IGV Step DSH Increase	dshinstp			%	RO
14	IGV Step DSH Decrease	dshdestp			%	RO
15	Cond Press Trip Value	cp_trip			psig	RO
16	Condenser Pressure Override Value	cp_ov			psig	RO
17	High Inverter Temp	inov_fl	NO/YES			RO

LEGEND

*Default value is shown only if configurable in this table.

RO — Read Only

APPENDIX A — PIC6 SCREEN AND TABLE STRUCTURE (CONT)

Surge Correction

CCN TABLE NAME: MAISURGE

PIC6 PATH: Main Menu → Maintenance Menu → Surge Correction

LINE	PIC6 DESCRIPTION	CCN NAME	RANGE	DEFAULT VALUE*	UNIT	READ/WRITE
1	Surge Region 0 = No, 1 = Low, 2 = High, 3 = Deadband, 4 = Noise	act_reg	0 to 4			RO
2	Active Delta Tsat	dts_act			°F	RO
3	Calc Ref Delta Tsat	dts_cal			°F	RO
4	High Eff Delta Tsat	dts_he			°F	RO
5	Amps Change Surge Prot	amps_dta			%	RO
6	Max Amps Change Value	amch_max			%	RO
7	Surge Counts	sc				RO
8	Surge Protection Counts	spc				RO
9	Surge Prevention Active	surg_act	NO/YES			RO
10	Surge Protection Active	surg_pro	NO/YES			RO
11	EC/HG Valve Change Flag 0 = Close, 1 = Hold, 2 = Open	hgbp_chg	0 to 2			RO
12	Cal Surge Delta Tmax	dts_maxc	0 to 150.0		°F	RO
13	Cal Surge Delta Tmin	dts_minc	0 to 150.0		°F	RO
14	Cal Surge Delta Tsmcd	dts_medc	0 to 150.0		°F	RO
15	Opti-Sound IGV1 Position	gvi_smed			%	RO
16	Envelope Line/HG Optimized	enlp_opt	NO/YES			RO

LEGEND

*Default value is shown only if configurable in this table.

RO — Read Only

Maintenance VFD Config

CCN TABLE NAME: VFD_MCFG

PIC6 PATH: Main Menu → Maintenance Menu → Maintenance VFD Config

LINE	PIC6 DESCRIPTION	CCN NAME	RANGE	DEFAULT VALUE	UNIT	READ/WRITE
1	VFD Config Conflict	vfd_cflt	NO/YES	No		RO
2	Delete VFD Config Yes = Delete, No = Keep	del_vfdc	NO/YES	No		RW
3	Rated Line Voltage	rlv_i		460	V	RO
4	Motor Rated Load Current	rla_load		200	amps	RO
5	Motor Nameplate Current	rla		200	amps	RO
6	Motor Nameplate Voltage	rlv		460	volts	RO
7	Motor Nameplate RPM	rpm		3000	rpm	RO
8	Motor Nameplate kW	rlkw		1500	kW	RO
9	Compressor Speed 100%	comp_100		50	Hz	RO
10	Skip Frequency 1	skipfrq1		102	Hz	RO
11	Skip Frequency 2	skipfrq2		102	Hz	RO
12	Skip Frequency 3	skipfrq3		102	Hz	RO
13	Skip Frequency Band	skipband		0	Hz	RO
14	Increase Ramp Time	ramp_inc		30	sec	RO
15	Decrease Ramp Time	ramp_dec		30	sec	RO
16	Line Voltage Imbalance%	lvim_th		10	%	RO
17	Line Volt Imbalance Time	lvim_per		10	sec	RO
18	Line Current Imbalance%	lcim_th		40	%	RO
19	Line Current Imbal Time	lcim_per		10	sec	RO
20	Motor Current Imbalance	mcim_th		40	%	RO
21	Motor Current Imbal Time	mcim_per		10	sec	RO
22	Single Cycle Dropout	scycd_en	DISABLE/ENABLE	DISABLE		RO
23	PWM Switch Frequency 0 = 2 kHz, 1 = 4 kHz	pwm_freq	0/1	0		RO
24	Restore Defaults	res_def	NO/YES	No		RO
25	Communication Timeout	com_tout		10	sec	RO

LEGEND

RO — Read Only

RW — Read/Write

APPENDIX A — PIC6 SCREEN AND TABLE STRUCTURE (CONT)

Swift Restart

CCN TABLE NAME: MAISRST

PIC6 PATH: Main Menu → Maintenance Menu → Swift Restart

LINE	PIC6 DESCRIPTION	CCN NAME	RANGE	DEFAULT VALUE*	UNIT	READ/WRITE
1	SRD Position @Shutdown	srd_shut	0 to 100		%	RO
2	VFD Speed @Shutdown	vfd_shut	0 to 100		%	RO
3	GV1 Position @Shutdown	gv1_shut	0 to 100		%	RO
4	Evap Sat Temp @Shutdown	est_shut	-40 to 280		°F	RO
5	Power Recovery Duration	pd_dur	0 to 65535		min	RO
6	Power Down Active	power_dn	NO/YES			RO
7	Auto Restart Active	auto_rst	NO/YES			RO
8	Swift Restart Active	sw_rst	NO/YES			RO

Power Line Parameters

CCN TABLE NAME: POWER_I

PIC6 PATH: Main Menu → Maintenance Menu → Power Line Parameters

LINE	PIC6 DESCRIPTION	CCN NAME	RANGE	DEFAULT VALUE*	UNIT	READ/WRITE
1	Line Current Phase 1	LN_AMPS1			amp	RO
2	Line Current Phase 2	LN_AMPS2			amp	RO
3	Line Current Phase 3	LN_AMPS3			amp	RO
4	Actual Line Current	AMPS_A			amp	RO
5	Percent Line Current	AMPS_P			%	RO
6	Ground Fault Phase 1	GRFT_1			amp	RO
7	Ground Fault Phase 2	GRFT_2			amp	RO
8	Ground Fault Phase 3	GRFT_3			amp	RO
9	Line Voltage Phase 1	LN_VOLT1			V	RO
10	Line Voltage Phase 2	LN_VOLT2			V	RO
11	Line Voltage Phase 3	LN_VOLT3			V	RO
12	Actual Line Voltage	VOLT_A			V	RO
13	Percent Line Voltage	VOLT_P			%	RO
14	Line Kilowatts	KW			kW	RO
15	Line Kilowatts Hours	KWH			kW	RO
16	Line Frequency	LN_FREQ			Hz	RO
17	Line Power Factor	POW_FACT				RO
18	Line Current Imbalance%	ln_imb_i			%	RO
19	Line Voltage Imbalance%	ln_imb_v			%	RO

ISM or VFD History

CCN TABLE NAME: MAISMH

PIC6 PATH: Main Menu → Maintenance Menu → ISM or VFD History

LINE	PIC6 DESCRIPTION	CCN NAME	RANGE	DEFAULT VALUE*	UNIT	READ/WRITE
1	Line Current Phase 1	AMPS_H1			amp	RO
2	Line Current Phase 2	AMPS_H2			amp	RO
3	Line Current Phase 3	AMPS_H3			amp	RO
4	Line Frequency	FREQ_H			Hz	RO
5	Ground Fault Phase 1	GRFT_H1			amp	RO
6	Ground Fault Phase 2	GRFT_H2			amp	RO
7	Ground Fault Phase 3	GRFT_H3			amp	RO
8	Phase 1 Faulted	phase_h1	NO/YES			RO
9	Phase 2 Faulted	phase_h2	NO/YES			RO
10	Phase 3 Faulted	phase_h3	NO/YES			RO
11	VFD Alarm Code	alm_code	NO/YES			RO
12	I2T Sum Heat Phase 1	sum1ht_h			%	RO
13	I2T Sum Heat Phase 2	sum2ht_h			%	RO
14	I2T Sum Heat Phase 3	sum3ht_h			%	RO
15	Line Voltage Phase 1	VOLT_H1			V	RO
16	Line Voltage Phase 2	VOLT_H2			V	RO
17	Line Voltage Phase 3	VOLT_H3			V	RO
18	Load Current Phase 1	ld_amp1			amp	RO
19	Load Current Phase 2	ld_amp2			amp	RO
20	Load Current Phase 3	ld_amp3			amo	RO
21	DC Bus Voltage	bus_volt			V	RO

LEGEND

RO — Read Only

*Default value is shown only if configurable in this table.

APPENDIX A — PIC6 SCREEN AND TABLE STRUCTURE (CONT)

Power Load Parameters

CCN TABLE NAME: POWER_O

PIC6 PATH: Main Menu → Maintenance Menu → Power Load Parameters

LINE	PIC6 DESCRIPTION	CCN NAME	RANGE	DEFAULT VALUE*	UNIT	READ/WRITE
1	VFD Load Current	VFD_LOAD			amp	RO
2	Percent VFD Load Current	amps_p_o			%	RO
3	Ground Fault Current	gf_amps			amp	RO
4	Motor Current Imbalance	mt_imb_i			%	RO
5	Motor Actual Frequency	MOT_FREQ			Hz	RO
6	Motor Target Frequency	tgt_freq			Hz	RO
7	Actual VFD Speed Per	vfd_act			%	RO
8	DC Bus Voltage	bus_volt			V	RO
9	DC Bus Voltage Reference	bus_ref			V	RO
10	Load Current Ph 1(U)	ld_amps1			amp	RO
11	Load Current Ph 2(V)	ld_amps2			amp	RO
12	Load Current Ph 3(W)	ld_amps3			amp	RO
13	Motor Power Factor	motor_pf				RO
14	Motor Kilowatts	motor_kw			kW	RO
15	Motor Kilowatt-Hours	motorkwh				RO
16	Motor Overload	motor_ov			%	RO
17	Rectifier Overload	rect_ov			%	RO
18	Inverter Overload	inv_ov			%	RO
19	VFD Enclosure Temp	enc_temp			°F	RO
20	VFD Cold Plate Temp	cp_temp			°F	RO
21	Inverter Temperature	inv_temp			°F	RO
22	Rectifier Temperature	rec_temp			°F	RO
23	Shunt Trip Relay Status	triplr	0 to 1			RO
24	Precharge Relay Status	prechar	0 to 1			RO
25	VFD Run Relay Status	vfd_run	0 to 1			RO
26	Precharge Feedback	prech_fd	0 to 1			RO
27	VFD Load Factor	VFD_FACT				RO
28	LR Temp Switch	lrtem_sw	0 to 1			RO
29	VFD Alarm Code	alm_code				RO
30	VFD Status Word	stat_wd				RO
31	VFD Command Word	cmd_wd				RO
32	Safety Stop Status	safestop	0 to 1			RO
33	SPD Feedback	spd_fd	0 to 1			RO
34	High VFD Current	VFDC_HI	NO/YES			RO

LEGEND

RO — Read Only

*Default value is shown only if configurable in this table.

APPENDIX A — PIC6 SCREEN AND TABLE STRUCTURE (CONT)

VFD Status

CCN TABLE NAME: VFD_STAT

PIC6 PATH: Main Menu → Maintenance Menu → UM VFD Status

LINE	PIC6 DESCRIPTION	CCN NAME	RANGE	DEFAULT VALUE	UNIT	READ/WRITE
1	Single Cycle Dropout	cycle_1	NO/YES	NO		RO
2	Line Current Imbalance	lineim_i	NO/YES	NO		RO
3	High Line Voltage	hi_volt	NO/YES	NO		RO
4	Low Line Voltage	low_volt	NO/YES	NO		RO
5	Low DC Bus Voltage	lo_dcbus	NO/YES	NO		RO
6	High DC Bus Voltage	hi_dcbus	NO/YES	NO		RO
7	VFD Power On Reset	vfd_por	NO/YES	NO		RO
8	Ground Fault	grnd_flt	NO/YES	NO		RO
9	Line Phase Reversal	ph_rev	NO/YES	NO		RO
10	Motor Overload Trip	motor_ov	NO/YES	NO		RO
11	Start Complete	start_ok	NO/YES	NO		RO
12	Rectifier Power Fault	rect_pu	NO/YES	NO		RO
13	Invert Power Fault	inv_pu	NO/YES	NO		RO
14	Rectifier Overcurrent	rect_oi	NO/YES	NO		RO
15	Inverter Overcurrent	inv_oi	NO/YES	NO		RO
16	Condenser High Pressure	prs_trip	NO/YES	NO		RO
17	Motor Amps Not Sensed	no_amps	NO/YES	NO		RO
18	Motor Acceleration Fault	acclfft	NO/YES	NO		RO
19	Stop Complete	stop_ok	NO/YES	NO		RO
20	Stop Fault	ampstop	NO/YES	NO		RO
21	Rectifier Overtemp	rect_ot	NO/YES	NO		RO
22	Inverter Overtemp	inv_ot	NO/YES	NO		RO
23	Motor Current Imbalance	motim_i	NO/YES	NO		RO
24	Line Voltage Imbalance	lineim_v	NO/YES	NO		RO
25	Frequency Fault	freqflt	NO/YES	NO		RO
26	VFD Comm Fault	vfd_comm	NO/YES	NO		RO
27	VFD Fault	vfdfault	NO/YES	NO		RO
28	Read Config Complete	readone	NO/YES	NO		RO
29	VFD Start Inhibit	strt_inh	NO/YES	NO		RO
30	VFD Checksum Error	checksum	NO/YES	NO		RO
31	Inductor Overtemp Switch	inot_sw	NO/YES	NO		RO
32	Incompatibility Fault	incomp	NO/YES	NO		RO

LEGEND

RO — Read Only

APPENDIX A — PIC6 SCREEN AND TABLE STRUCTURE (CONT)

Maintenance Others

CCN TABLE NAME: MAIOTHER

PIC6 PATH: Main Menu → Maintenance Menu → Maintenance Others

LINE	PIC6 DESCRIPTION	CCN NAME	RANGE	DEFAULT VALUE*	UNIT	READ/WRITE
1	5V Sensor Power Monitor	tran_v			V	RO
2	Evap Pres Trans Volts	evapp_v			V	RO
3	Cond Pres Trans Volts	condp_v			V	RO
4	Econ Pres Trans Volts	econp_v			V	RO
5	Diffuser Pres Tran Volts	diffp_v			V	RO
6	Oil Sump Pres Tran Volts	opsmp_v			V	RO
7	Oil Sup Pres Trans Volts	opdis_v			V	RO
8	Evap Enter Water Volts	evewp_v			V	RO
9	Evap Leave Water Volts	evlwp_v			V	RO
10	Cond Enter Water Volts	cdewp_v			V	RO
11	Cond Leave Water Volts	cdlwp_v			V	RO
12	Bearing In Trans Volt	brgi_v			V	RO
13	Bearing Out Trans Volt	brgo_v			V	RO
14	Pump Output Trans Volt	pumpo_v			V	RO
15	Pump Input Trans Volt	pumpi_v			V	RO
16	Last Cond Pump Run Time	last_cpt				RO
17	Prestart Check Status	pre_chck				RO
18	GV1 Pos at Startup OK	gvpos_ok				RO
19	Pump PD at Startup OK	pumpdp_ok				RO
20	ECV Pos at Startup OK	hgbp_ok				RO
21	ECV Pos at Startup OK	hgbp_ok	NO/YES			RO
22	Damper Pos at Startup OK	dmp_ok	NO/YES			RO
23	Oil Pump Req Oil Heater	op_heat	NO/YES			RO
24	Oil Pump Req Prestart	op_prest	NO/YES			RO
25	Oil Pump Req Startup	op_start	NO/YES			RO
26	Oil Pump Req Shutdown	op_shut	NO/YES			RO
27	Oil Pump Req Swift Rst	op_srst	NO/YES			RO
28	Evap Pump Req Startup	ep_start	NO/YES			RO
29	Evap Pump Req Diagnostic	ep_diag	NO/YES			RO
30	Evap Pump Req Frozen	ep_freze	NO/YES			RO
31	Evap Pump Req Shutdown	ep_shut	NO/YES			RO
32	Evap Pump Req Pumpdown	ep_pdown	NO/YES			RO
33	Cond Pump Req Prestart	cp_prest	NO/YES			RO
34	Cond Pump Req Startup	cp_start	NO/YES			RO
35	Cond Pump Req Override	cp_overr	NO/YES			RO
36	Cond Pump Req Shutdown	cp_shut	NO/YES			RO
37	Cond Pump Req Tower	cp_tower	NO/YES			RO
38	Cond Pump Req Diagnostic	co_diag	NO/YES			RO
39	Cond Pump Req Frozen	cp_freze	NO/YES			RO
40	Cond Pump Req Pumpdown	cp_pdown	NO/YES			RO
41	Capacity Inhibit Ramping	cap_inhr	NO/YES			RO
42	Capacity Inhibit Demand	cap_inhd	NO/YES			RO
43	Capacity Decrease Demand	cap_decd	NO/YES			RO
44	Guide Vane Inh Surge	gv1_inhs	NO/YES			RO
45	Capacity Decrease Surge	cap_decs	NO/YES			RO
46	Capacity Inh Low SST	capinhst	NO/YES			RO
47	Capacity Dec Low SST	capdecst	NO/YES			RO
48	Capacity Inh Cond Pres	capinhcp	NO/YES			RO
49	Capacity Dec Cond Pres	capdeccp	NO/YES			RO
50	Capacity Inh Motor Temp	capinhmt	NO/YES			RO
51	Capacity Dec Motor Temp	capdecmt	NO/YES			RO
52	Capacity Inh Hi Current	capinham	NO/YES			RO
53	Capacity Dec Hi Current	capdecam	NO/YES			RO
54	Capacity Dec Low Temp	capdecls	NO/YES			RO
55	GV2 Position at Startup OK	gv2posok	NO/YES			RO
56	Capacity Inh Inverter	capinhiv	NO/YES			RO
57	Capacity Dec Inverter	capdeciv	NO/YES			RO

LEGEND

RO — Read Only

*Default value is shown only if configurable in this table.

APPENDIX A — PIC6 SCREEN AND TABLE STRUCTURE (CONT)

Maintenance IOB

CCN TABLE NAME: MAIIOB

PIC6 PATH: Main Menu → Maintenance Menu → Maintenance IOB

LINE	PIC6 DESCRIPTION	CCN NAME	RANGE	DEFAULT VALUE*	UNIT	READ/WRITE
1	IOB1 Power Supply Volt	vol_job1			V	RO
2	IOB1 Num Peak Prev Sec	nm_peak1				RO
3	IOB1 Low Voltage Flag	low_vol1	NO/YES			RO
4	IOB1 24VAC Fuse Status	fusstat1	CLOSE/OPEN			RO
5	IOB2 Power Supply Volt	vol_job2			V	RO
6	IOB2 Num Peak Prev Sec	nm_peak2				RO
7	IOB2 Low Voltage Flag	low_vol2	NO/YES			RO
8	IOB2 24VAC Fuse Status	fusstat2	CLOSE/OPEN			RO
9	IOB3 Power Supply Volt	vol_job3			V	RO
10	IOB3 Num Peak Prev Sec	nm_peak3				RO
11	IOB3 Low Voltage Flag	low_vol3	NO/YES			RO
12	IOB3 24VAC Fuse Status	fusstat3	CLOSE/OPEN			RO
13	IOB4 Power Supply Volt	vol_job4			V	RO
14	IOB4 Num Peak Prev Sec	nm_peak4				RO
15	IOB4 Low Voltage Flag	low_vol4	NO/YES			RO
16	IOB4 24VAC Fuse Status	fusstat4	CLOSE/OPEN			RO
17	IOB5 Power Supply Volt	vol_job5			V	RO
18	IOB5 Num Peak Prev Sec	nm_peak5				RO
19	IOB5 Low Voltage Flag	low_vol5	NO/YES			RO
20	IOB5 24VAC Fuse Status	fusstat5	CLOSE/OPEN			RO
21	IOB6 Power Supply Volt	vol_job6			V	RO
22	IOB6 Num Peak Prev Sec	nm_peak6				RO
23	IOB6 Low Voltage Flag	low_vol6	NO/YES			RO
24	IOB6 24VAC Fuse Status	fusstat6	CLOSE/OPEN			RO

Board Software PN

CCN TABLE NAME: MAI_BDSN

PIC6 PATH: Main Menu → Maintenance Menu → Board Software PN

LINE	PIC6 DESCRIPTION	CCN NAME	RANGE	DEFAULT VALUE*	UNIT	READ/WRITE
1	IOB #1 Soft Part Number	sn_job1				RO
2	IOB #2 Soft Part Number	sn_job2				RO
3	IOB #3 Soft Part Number	sn_job3				RO
4	IOB #4 Soft Part Number	sn_job4				RO
5	IOB #5 Soft Part Number	sn_job5				RO
6	SIOB Software Part Number	sn_siob				RO
7	ISM Software Part Number	sn_ism				RO
8	Gateway Soft Part Number	sn_gw				RO
9	DCIB Soft Part Number	sn-dcib				RO
10	MBB SVN Revision	svn_rev				RO

LEGEND











RO — Read Only

*Default value is shown only if configurable in this table.

APPENDIX A — PIC6 SCREEN AND TABLE STRUCTURE (CONT)

Pressure Sensor Calib (PRES_CAL) Menu Description

Navigation: MAIN MENU → MAINTENANCE MENU → PRESSURE SENSOR CALIB

ICON	DISPLAYED TEXT	ACCESS	ASSOCIATED TABLE	PAGE NO.
	Evap Pressure Sensor	Service	PRSCAL01	76
	Cond Pressure Sensor	Service	PRSCAL02	76
	Evap Entering Water P	Service	PRSCAL07	76
	Evap Leaving Water P	Service	PRSCAL08	77
	Cond Entering Water P	Service	PRSCAL09	77
	Cond Leaving Water P	Service	PRSCAL10	77
	Pump Input Press Cali	Service	PRSCAL11	77
	Bearing Inlet Pressure	Service	PRSCAL12	78
	Bearing Outlet Pressure	Service	PRSCAL13	78
	Pump Outlet Pressure	Service	PRSCAL14	78

APPENDIX A — PIC6 SCREEN AND TABLE STRUCTURE (CONT)

Evap Pressure Sensor

CCN TABLE NAME: PRSCAL01

PIC6 PATH: Main Menu → Maintenance Menu → Pressure Sensor Calib → Evap Pressure Sensor

LINE	PIC6 DESCRIPTION	CCN NAME	RANGE	DEFAULT VALUE	UNIT	READ/WRITE
1	Evap Pressure Sensor					
2	Calibration Enable	cal_en	DISABLE/ENABLE	DISABLE		RW
3	Calibration Completed	cal_st	NO/YES	NO		RO
4	Calibrated Slope	cal_s				RO
5	Calibrated Intercept	cal_i				RO
6	Current Pressure	cur_pres			psig	RO
7	Calib Press1 (0 PSI)	cal_p1	9 digit numeric string	0	psig	RW
8	Calib Press2 (10-30PSI)	cal_p2	9 digit numeric string	0	psig	RW

LEGEND

RO — Read Only
RW — Read/Write

Cond Pressure Sensor

CCN TABLE NAME: PRSCAL02

PIC6 PATH: Main Menu → Maintenance Menu → Pressure Sensor Calib → Cond Pressure Sensor

LINE	PIC6 DESCRIPTION	CCN NAME	RANGE	DEFAULT VALUE	UNIT	READ/WRITE
1	Cond Pressure Sensor					
2	Calibration Enable	cal_en	DISABLE/ENABLE	DISABLE		RW
3	Calibration Completed	cal_st	NO/YES	NO		RO
4	Calibrated Slope	cal_s				RO
5	Calibrated Intercept	cal_i				RO
6	Current Pressure	cur_pres			psig	RO
7	Calib Press1 (0 PSI)	cal_p1	9 digit numeric string	0	psig	RW
8	Calib Press2 (10-30PSI)	cal_p2	9 digit numeric string	0	psig	RW

LEGEND

RO — Read Only
RW — Read/Write

Evap Entering Water P

CCN TABLE NAME: PRSCAL07

PIC6 PATH: Main Menu → Maintenance Menu → Pressure Sensor Calib → Evap Entering Water P

LINE	PIC6 DESCRIPTION	CCN NAME	RANGE	DEFAULT VALUE	UNIT	READ/WRITE
1	Evap Entering Water P					
2	Calibration Enable	cal_en	DISABLE/ENABLE	DISABLE		RW
3	Calibration Completed	cal_st	NO/YES	NO		RO
4	Calibrated Slope	cal_s				RO
5	Calibrated Intercept	cal_i				RO
6	Current Pressure	cur_pres			psig	RO
7	Calib Press1 (0 PSI)	cal_p1	9 digit numeric string	0	psig	RW
8	Calib Press2 (100-250PSI)	cal_p2	9 digit numeric string	0	psig	RW

LEGEND

RO — Read Only

APPENDIX A — PIC6 SCREEN AND TABLE STRUCTURE (CONT)

Evap Leaving Water P

CCN TABLE NAME: PRSCAL08

PIC6 PATH: Main Menu → Maintenance Menu → Pressure Sensor Calib → Evap Leaving Water P

LINE	PIC6 DESCRIPTION	CCN NAME	RANGE	DEFAULT VALUE	UNIT	READ/WRITE
1	Evap Leaving Water P					
2	Calibration Enable	cal_en	DISABLE/ENABLE	DISABLE		RW
3	Calibration Completed	cal_st	NO/YES	NO		RO
4	Calibrated Slope	cal_s				RO
5	Calibrated Intercept	cal_i				RO
6	Current Pressure	cur_pres			psig	RO
7	Calib Press1 (0 PSI)	cal_p1	9 digit numeric string	0	psig	RW
8	Calib Press2 (100-250PSI)	cal_p2	9 digit numeric string	0	psig	RW

LEGEND

RO — Read Only
RW — Read/Write

Cond Entering Water P

CCN TABLE NAME: PRSCAL09

PIC6 PATH: Main Menu → Maintenance Menu → Pressure Sensor Calib → Cond Entering Water P

LINE	PIC6 DESCRIPTION	CCN NAME	RANGE	DEFAULT VALUE	UNIT	READ/WRITE
1	Cond Entering Water P					
2	Calibration Enable	cal_en	DISABLE/ENABLE	DISABLE		RW
3	Calibration Completed	cal_st	NO/YES	NO		RO
4	Calibrated Slope	cal_s				RO
5	Calibrated Intercept	cal_i				RO
6	Current Pressure	cur_pres			psig	RO
7	Calib Press1 (0 PSI)	cal_p1	9 digit numeric string	0	psig	RW
8	Calib Press2 (100-250PSI)	cal_p2	9 digit numeric string	0	psig	RW

LEGEND

RO — Read Only
RW — Read/Write

Cond Leaving Water P

CCN TABLE NAME: PRSCAL10

PIC6 PATH: Main Menu → Maintenance Menu → Pressure Sensor Calib → Cond Leaving Water P

LINE	PIC6 DESCRIPTION	CCN NAME	RANGE	DEFAULT VALUE	UNIT	READ/WRITE
1	Cond Leaving Water P					
2	Calibration Enable	cal_en	DISABLE/ENABLE	DISABLE		RW
3	Calibration Completed	cal_st	NO/YES	NO		RO
4	Calibrated Slope	cal_s				RO
5	Calibrated Intercept	cal_i				RO
6	Current Pressure	cur_pres			psig	RO
7	Calib Press1 (0 PSI)	cal_p1	9 digit numeric string	0	psig	RW
8	Calib Press2 (100-250PSI)	cal_p2	9 digit numeric string	0	psig	RW

LEGEND

RO — Read Only
RW — Read/Write

Pump Input Press Cali

CCN TABLE NAME: PRSCAL11

PIC6 PATH: Main Menu → Maintenance Menu → Pressure Sensor Calib → Pump Input Press Cali

LINE	PIC6 DESCRIPTION	CCN NAME	RANGE	DEFAULT VALUE	UNIT	READ/WRITE
1	Pump Input Press Cali	cal_en	DISABLE/ENABLE	DISABLE		RW
2	Calibration Completed	cal_st	NO/YES	NO		RO
3	Calibrated Slope	cal_s				RO
4	Calibrated Intercept	cal_i				RO
5	Current Pressure	cur_pres			psig	RO
6	Calib Press1 (0 PSI)	cal_p1	9 digit numeric string	0	psig	RW
8	Calib Press2 (10-30PSI)	cal_p2	9 digit numeric string	0	psig	RW

LEGEND

RO — Read Only
RW — Read/Write

APPENDIX A — PIC6 SCREEN AND TABLE STRUCTURE (CONT)

Bearing Inlet Pressure

CCN TABLE NAME: PRSCAL12

PIC6 PATH: Main Menu → Maintenance Menu → Pressure Sensor Calib → Bearing Inlet Pressure

LINE	PIC6 DESCRIPTION	CCN NAME	RANGE	DEFAULT VALUE	UNIT	READ/WRITE
1	Pump Input Press Cali	cal_en	DISABLE/ENABLE	DISABLE		RW
2	Calibration Completed	cal_st	NO/YES	NO		RO
3	Calibrated Slope	cal_s				RO
4	Calibrated Intercept	cal_i				RO
5	Current Pressure	cur_pres			psig	RO
6	Calib Press1 (0 PSI)	cal_p1	9 digit numeric string	0	psig	RW
8	Calib Press2 (10-30PSI)	cal_p2	9 digit numeric string	0	psig	RW

LEGEND

RO — Read Only
RW — Read/Write

Bearing Outlet Pressure

CCN TABLE NAME: PRSCAL13

PIC6 PATH: Main Menu → Maintenance Menu → Pressure Sensor Calib → Bearing Outlet Pressure

LINE	PIC6 DESCRIPTION	CCN NAME	RANGE	DEFAULT VALUE	UNIT	READ/WRITE
1	Pump Input Press Cali	cal_en	DISABLE/ENABLE	DISABLE		RW
2	Calibration Completed	cal_st	NO/YES	NO		RO
3	Calibrated Slope	cal_s				RO
4	Calibrated Intercept	cal_i				RO
5	Current Pressure	cur_pres			psig	RO
6	Calib Press1 (0 PSI)	cal_p1	9 digit numeric string	0	psig	RW
8	Calib Press2 (10-30PSI)	cal_p2	9 digit numeric string	0	psig	RW

LEGEND

RO — Read Only
RW — Read/Write

Pump Outlet Pressure

CCN TABLE NAME: PRSCAL14

PIC6 PATH: Main Menu → Maintenance Menu → Pressure Sensor Calib → Pump Outlet Pressure

LINE	PIC6 DESCRIPTION	CCN NAME	RANGE	DEFAULT VALUE	UNIT	READ/WRITE
1	Pump Input Press Cali	cal_en	DISABLE/ENABLE	DISABLE		RW
2	Calibration Completed	cal_st	NO/YES	NO		RO
3	Calibrated Slope	cal_s				RO
4	Calibrated Intercept	cal_i				RO
5	Current Pressure	cur_pres			psig	RO
6	Calib Press1 (0 PSI)	cal_p1	9 digit numeric string	0	psig	RW
8	Calib Press2 (10-30PSI)	cal_p2	9 digit numeric string	0	psig	RW

LEGEND

RO — Read Only
RW — Read/Write

Temp Sensor Calib

CCN TABLE NAME: TEMP_CAL

PIC6 PATH: Main Menu → Maintenance Menu → Temp Sensor Calib

LINE	PIC6 DESCRIPTION	CCN NAME	RANGE	DEFAULT VALUE*	UNIT	READ/WRITE
1	Entering Chilled Water	ECW			°F	RO
2	ECW Sensor Raw Temp	ECW_RAW			°F	RO
3	ECW Temperature Offset	ECW_OFF	-2.0 to 2.0	0	°F	RW
4	Leaving Chilled Water	LCW			°F	RO
5	LCW Sensor Raw Temp	LCW_RAW			°F	RO
6	LCW Temperature Offset	LCW_OFF	-2.0 to 2.0	0	°F	RW
7	Entering Condenser Water	ECDW			°F	RO
8	ECDW Sensor Raw Temp	ECDW_RAW			°F	RO
9	ECDW Temperature Offset	ECDW_OFF	-2.0 to 2.0	0	°F	RW
10	Leaving Condenser Water	LCDW			°F	RO
11	LCDW Sensor Raw Temp	LCDW_RAW			°F	RO
12	LCDW Temperature Offset	LCDW_OFF	-2.0 to 2.0	0	°F	RW

LEGEND

RO — Read Only
RW — Read/Write

*Default value is shown only if configurable in this table.

APPENDIX A — PIC6 SCREEN AND TABLE STRUCTURE (CONT)

System Status

CCN TABLE NAME: SYS_STAT

PIC6 PATH: Main Menu → Maintenance Menu → System Status

LINE	PIC6 DESCRIPTION	CCN NAME	RANGE	DEFAULT VALUE*	UNIT	READ/WRITE
1	System Control Mode	sys_ctlm				RO
2	System Status	sys_stat				RO
3	Master Run Status	mas_stat				RO
4	Slave Run Status	sla_stat				RO
5	System Percent Load	sys_perl			%	RO
6	System KW	sys_kw			kW	RO
7	System Control Point	sys_stlp			°F	RO
8	System Demand Limit	sys_dem			%	RO
9	Supply Liquid Temp	sys_supt				RO
10	Return Liquid Temp	sys_rent				RO

LEGEND

*Default value is shown only if configurable in this table.

RO — Read Only

AHF Status

CCN TABLE NAME: AHF_STAT

PIC6 PATH: Main Menu → Maintenance Menu → AHF Status

LINE	PIC6 DESCRIPTION	CCN NAME	RANGE	DEFAULT VALUE*	UNIT	READ/WRITE
1	AHF Ready	ahfready	yes/no			RO
2	AHF Control Cmd (0=Stop, 1=Run, 2=Reset)	ahf_cmd	0 to 2	1		RW
3	AHF Status (0=Stop, 1=Run)	ahf_stat	0 to 1			RO
4	AHF Fault Status	ahffault	No/Yes			RO
5	AHF Alarm Status	ahfalarm	No/Yes			RO
6	Module Temperature	ahf_temp			F	RO
7	DC Bus Voltage	ahfdcbus			V	RO
8	Grid Voltage A	ahfvolta			V	RO
9	Grid Voltage B	ahfvoltb			V	RO
10	Grid Voltage C	ahfvoltc			V	RO
11	Apparent Power (KVA)	Spower				RO
12	Grid Frequency	gridfre			Hz	RO
13	Grid Power Factor	gridPF				RO
14	Grid THDia	gridthdia			%	RO
15	Grid THDib	gridthdib			%	RO
16	Grid THDic	gridthdic			%	RO
17	Load THDia	loadthdia			%	RO
18	Load THDib	loadthdib			%	RO
19	Load THDic	loadthdic			%	RO
20	Current Phase A	ahfia			Amp	RO
21	Current Phase B	ahfib			Amp	RO
22	Current Phase C	ahfic			Amp	RO
23	Compensation ia	comp_ia			Amp	RO
24	Compensation ib	comp_ib			Amp	RO
25	Compensation ic	comp_ic			Amp	RO

LEGEND

RO — Read Only

*Default value is shown only if configurable in this table.

APPENDIX A — PIC6 SCREEN AND TABLE STRUCTURE (CONT)

System Configuration

CCN TABLE NAME: N/A

PIC6 PATH: Main Menu → System Configuration

LINE	PIC6 DESCRIPTION	CCN NAME	RANGE	DEFAULT VALUE*	UNIT	READ/WRITE
1	Date/Time Configuration					
2	Current Date					
3	Current Time					
4	Config Date					RW
5	Config Time					RW
6	Time Zone					RW
7	Time Zone Status					
8	NTP Server					RW
9	Frequency of Sync					RW
10	Time Sync/User Choice		1 Shot, Recurring, Stop			
11	Status					
12	Ethernet Configuration					
13	Interface: eth0					
14	MAC address					
15	IP address					
16	Net mask					
17	Gateway IP					
18	Set IP					RW
19	Set net mask					RW
20	Not Applied		Not Applied, Apply			
21	Interface: eth1					
22	MAC address					
23	IP address					
24	Net mask					
25	Gateway IP					
26	Set IP					RW
27	Set net mask					RW
28	Not Applied		Not Applied, Apply			
29	Gateway/DNS					
30	Gateway 1 IP					RW
31	Gateway 1 Destination/ Mask					RW
32	Gateway 1 IP					
33	Status					
34	Not Applied		Not Applied, Apply			
35	Gateway 2 IP					RW
36	Gateway 1 Destination/ Mask					RW
37	Gateway 1 IP					
38	Status					
39	Not Applied		Not Applied, Apply			
40	DNS IP 1					RW
41	DNS IP2					RW
42	Status					
43	Not Applied		Not Applied, Apply			
44	Wifi Configuration					
45	LEN Diagnostic					
46	Terminal Resister					



LEGEND

RW — Read/Write

*Default value is shown only if configurable in this table.

APPENDIX A — PIC6 SCREEN AND TABLE STRUCTURE (CONT)

Alarms Menu Description

ICON	DISPLAYED TEXT	ACCESS	ASSOCIATED TABLE	PAGE NO.
	Reset Alarms	All	ALARMRST	81
	Current Alarms	All	CUR_ALM	
	History Alarms	All	ALMHIST1	

Alarm Reset

CCN TABLE NAME: ALARMRST

PIC6 PATH: Main Menu → Alarm Menu → Alarm Reset

LINE	PIC6 DESCRIPTION	CCN NAME	RANGE	DEFAULT VALUE*	UNIT	READ/WRITE
1	Alarm Reset	RST_ALM	NO/YES	NO		RW
2	Alarm State	ALM_STAT				RO
3	Current Alarm 1	alarm_1c				RO
4	Current Alarm 2	alarm_2c				RO
5	Current Alarm 3	alarm_3c				RO
6	Current Alarm 4	alarm_4c				RO
7	Current Alarm 5	alarm_5c				RO

LEGEND

RO — Read Only
RW — Read/Write

*Default value is shown only if configurable in this table.

NOTE: For more information about viewing and resetting alarms, see the Diagnostics and Troubleshooting section on page 27.

APPENDIX B — IOB AND HMI DIP SWITCH SETTINGS

IOB Dip Switch Settings (Fig. F)

IOB	SW1 SETTING (1 TO 4)	SW2 SETTING (1 TO 10)
IOB-1	0000	0000000000
IOB-2	1000	0010000110
IOB-3	0100	0001010100
IOB-4	1100	0000000110

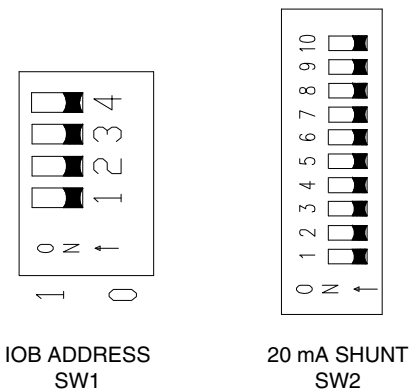

IOB-1 Dip Switch Settings

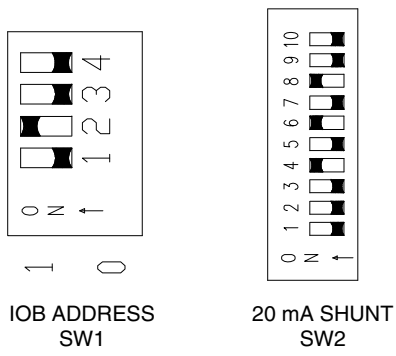

IOB-3 Dip Switch Settings

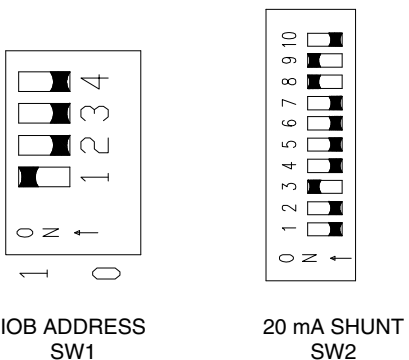

IOB-2 Dip Switch Settings

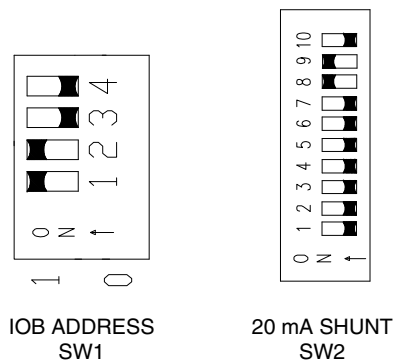

IOB-4 Dip Switch Settings

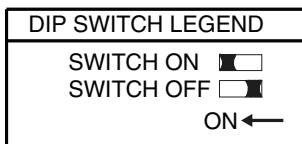

BLACK IS RAISED PORTION OF SWITCH

Fig. F — IOB Dip Switch Settings

APPENDIX C — INPUT/OUTPUT BOARD (IOB) STATUS INDICATORS

All control boards have LED indicators that show control board and communication status.

A red LED on each control module operates in the following manner:

- Power not present or power supply failure: LED is off
- Power present but microprocessor in Reset: LED is off
- Microprocessor operational but not communicating: LED flashes 3 seconds on, 3 seconds off

- Microprocessor operational and communicating with control system: LED flashes at 0.5 Hz rate (1 second on, 1 second off) in sync (± 100 ms) with all other new control modules on the same communication bus
- Microprocessor in boot mode: LED flashes at 0.2 seconds on, 0.2 seconds off

Each independent communication port has a green status LED. The green LED is on when data is being transmitted by the board.

All RS485 ports have a green LED.

APPENDIX D — NETWORK CONFIGURATION

OBJECT NAME	OBJECT TYPE	INSTANCE	OPTION	COVINC	PV ACCESS	DESCRIPTION
ALARMRST_alarm_1	AV	85	Type 6	0	RO	Jbus Current Alarm 1
ALARMRST_alarm_2	AV	86	Type 6	0	RO	Jbus Current Alarm 2
ALARMRST_alarm_3	AV	87	Type 6	0	RO	Jbus Current Alarm 3
ALARMRST_alarm_4	AV	88	Type 6	0	RO	Jbus Current Alarm 4
ALARMRST_alarm_5	AV	89	Type 6	0	RO	Jbus Current Alarm 5
BACnet_COLOR	MV	8	Type 5	0	RO	Operation Status Color
BACnet_PRIME_V	AV	150	Type 6	0	RO	Value of Prime variable
CAPACTRL_cm_stat1	AV	95	Type 6	0	RO	Comp1 Run State Val
CAPACTRL_ctrl_wt	AV	90	Type 6	0	RO	Controlled Water Temp
CAPACTRL_gv1_tgt	AV	91	Type 6	0	RO	Target GV1 Pos
CAPACTRL_gv2_tgt	AV	92	Type 6	0	RO	Target GV2 Pos
CAPACTRL_hgbp_tp	AV	94	Type 6	0	RO	ECV Target Percent
CAPACTRL_vfd_tgt	AV	93	Type 6	0	RO	Target VFD Speed Per
CFGSURGE_gv1_pful	AV	127	Type 6	0	RO	IGV1 Full Load Position
CFGSURGE_gv1_pmin	AV	126	Type 6	0	RO	IGV1 Minimum Position
CFGSURGE_sgl_hoff	AV	130	Type 6	0	RO	Surge Line Upper DB
CFGSURGE_sgl_loff	AV	129	Type 6	0	RO	Surge Line Lower DB
CFGSURGE_sgl_off	AV	128	Type 6	0	RO	Surge Line Offset
CFGSURGE_sgl_pro	AV	134	Type 6	0	RO	Surge Profile Offset
CFGSURGE_sgl_shfh	AV	131	Type 6	0	RO	Surge Line Shape Factor
CFGSURGE_sgl_shfl	AV	132	Type 6	0	RO	Sound Line Shape Factor
CFGSURGE_sgl_spdf	AV	133	Type 6	0	RO	Surge Line Speed Factor
CONF_OPT_hgbp_opt	MV	6	Type 5	0	RO	EC Valve Option
CONF_OPT_hgbp_sel	MV	7	Type 5	0	RO	EC Valve Selection
CONF_PRG_oil_ft	AV	136	Type 6	0	RO	Oil Filter Failure
CONF_PRG_oil_qly	AV	135	Type 6	0	RO	Oil Quality
CONF_PRG_ref_chg	AV	138	Type 6	0	RO	Refrig Charge Status
CONF_PRG_tran_dev	AV	137	Type 6	0	RO	Transducer Deviation
CONNECT_bac_id	AV	140	Type 6	0	RO	BACnet Identifier
CONNECT_bacena	BV	63	Type 4	0	RO	BACnet/IP Enable
CONNECT_bacunit	BV	64	Type 4	0	RO	BACnet Metric Unit
CONNECT_network	AV	139	Type 6	0	RO	BACnet Network
FACTORY_chil_typ	MV	4	Type 5	0	RO	Chiller Type
FACTORY_vfd_opt	MV	5	Type 5	0	RO	VFD/Starter Option
GENUNIT_AMPS_P	AV	4	Type 6	0	RO	Percent Current
GENUNIT_BAC_OCC	BV	9	Type 4	0	RO	BACnet Occupied
GENUNIT_ch_state	AV	7	Type 6	0	RO	Chiller Status Code
GENUNIT_CHIL_OCC_rd	BV	3	Type 4	0	RO	Network:Cmd Occupied
GENUNIT_CHIL_OCC_wr	BV	68	Type 1	0	RW	Chiller occupied?
GENUNIT_CHIL_S_S_rd	BV	2	Type 4	0	RO	Network:Cmd Start/Stop
GENUNIT_CHIL_S_S_wr	BV	66	Type 1	0	RW	Chiller Start/Stop
GENUNIT_ctl_mode	MV	1	Type 5	0	RO	Control Mode
GENUNIT_CTRL_PNT_rd	AV	1	Type 6	0	RO	Control Point
GENUNIT_CTRL_PNT_wr	AV	147	Type 2	0	RW	Control Point
GENUNIT_DEM_LIM_rd	AV	6	Type 6	0	RO	Actual Demand Limit
GENUNIT_DEM_LIM_wr	AV	148	Type 2	0	RW	Demand Limit
GENUNIT_EMSTOP_rd	BV	5	Type 4	0	RO	Emergency Stop
GENUNIT_EMSTOP_wr	BV	67	Type 1	0	RW	Emergency Stop
GENUNIT_FC_START_rd	BV	8	Type 4	0	RO	Start Free Cooling
GENUNIT_FC_START_wr	BV	69	Type 1	0	RW	Start Free Cooling
GENUNIT_HC_SEL_rd	BV	4	Type 4	0	RO	Cooling/Heating Select
GENUNIT_HC_SEL_wr	AV	149	Type 2	0	RW	Heatcool Select
GENUNIT_ice_occ	BV	7	Type 4	0	RO	Ice Schedule Occupied
GENUNIT_KW_P	AV	5	Type 6	0	RO	Motor Percent Kilowatts
GENUNIT_loc_occ	BV	6	Type 4	0	RO	Local Schedule Occupied
GENUNIT_reset	AV	2	Type 6	0	RO	Control Point Reset
GENUNIT_setpoint	AV	3	Type 6	0	RO	Actual Setpoint
GENUNIT_statstop	BV	1	Type 4	0	RO	Deter Start Stop Command
HYDRLIC_CDW_FLOW	BV	50	Type 4	0	RO	Condenser Water Flow
HYDRLIC_CDW_FV	AV	58	Type 6	0	RO	Cond Water Flow Value
HYDRLIC_cdw_pd	AV	59	Type 6	0	RO	Condenser Water Delta P
HYDRLIC_CDWP	BV	49	Type 4	0	RO	Condenser Water Pump

APPENDIX D — NETWORK CONFIGURATION (CONT)

OBJECT NAME	OBJECT TYPE	INSTANCE	OPTION	COVINC	PV ACCESS	DESCRIPTION
HYDRLIC_CHW_FLOW	BV	52	Type 4	0	RO	Chilled Water Flow
HYDRLIC_CHW_FV	AV	60	Type 6	0	RO	Chilled Water Flow Value
HYDRLIC_chw_pd	AV	61	Type 6	0	RO	Chilled Water Delta P
HYDRLIC_CHWP	BV	51	Type 4	0	RO	Chilled Water Pump
HYDRLIC_ctrlw_dt	AV	62	Type 6	0	RO	Controlled Water DT
INPUTS_DIFF_ACT	AV	47	Type 6	0	RO	Diffuser Actual Pos
INPUTS_DMP_ACT	MV	2	Type 5	0	RO	Damper Valve Status
INPUTS_E_STOP	BV	13	Type 4	0	RO	Emergency Stop Contact
INPUTS_FS_LOCK	BV	18	Type 4	0	RO	Fire Security Interlock
INPUTS_GV1_ACT	AV	44	Type 6	0	RO	Guide Vane 1 Actual Pos
INPUTS_GV2_ACT	AV	45	Type 6	0	RO	Guide Vane 2 Actual Pos
INPUTS_HF_LS	BV	23	Type 4	0	RO	Liquid Level Switch
INPUTS_HGBP_ACT	MV	3	Type 5	0	RO	EC Valve Status
INPUTS_HGBPACTP	AV	48	Type 6	0	RO	Actual ECV Pos Per
INPUTS_HP_SW	BV	11	Type 4	0	RO	High Pressure Switch
INPUTS_ICE_CON	BV	14	Type 4	0	RO	Ice Build Contact
INPUTS_PGLE_HI	BV	22	Type 4	0	RO	Purge Level Switch High
INPUTS_PGLE_LO	BV	21	Type 4	0	RO	Purge Level Switch Low
INPUTS_REM_CON	BV	12	Type 4	0	RO	Remote Contact
INPUTS_REM_LOCK	BV	15	Type 4	0	RO	Chiller Lockout
INPUTS_SAFETY	BV	16	Type 4	0	RO	Spare Safety Input
INPUTS_STAR_AUX	BV	10	Type 4	0	RO	Compressor Start Contact
INPUTS_STARTFLT	BV	17	Type 4	0	RO	Starter Fault Feedback
INPUTS_TRIPR	BV	19	Type 4	0	RO	ISM Trip Relay Status
INPUTS_VFD_ACT	AV	46	Type 6	0	RO	Actual VFD Speed Per
LABONLY_gv1_fc	BV	61	Type 4	0	RO	GV1 Forced
LABONLY_gv2_fc	BV	62	Type 4	0	RO	GV2 Forced
MAIN_MS_lag_s_s	BV	60	Type 4	0	RO	Slave Start/Stop
MAIN_MS_lagstart	AV	121	Type 6	0	RO	Lag Start Timer
MAIN_MS_lagstat	AV	120	Type 6	0	RO	Slave Run Status
MAIN_MS_lagstop	AV	122	Type 6	0	RO	Lag Stop Timer
MAIN_MS_lead_lag	AV	116	Type 6	0	RO	Unit is Lead or Lag
MAIN_MS_II_comm	BV	59	Type 4	0	RO	Lead Lag Communication
MAIN_MS_II_fault	AV	119	Type 6	0	RO	Master Slave Fault
MAIN_MS_II_hr_d	AV	125	Type 6	0	RO	Lead/Lag Hours Delta
MAIN_MS_ms_ctrl	AV	117	Type 6	0	RO	Master Control Type
MAIN_MS_preffit	AV	123	Type 6	0	RO	Prestart Fault Timer
MAIN_MS_pulltime	AV	124	Type 6	0	RO	Pulldown Timer
MAIN_MS_sl_ctrl	AV	118	Type 6	0	RO	Slave Control Type
MAIN_SRD_diff_alm	BV	58	Type 4	0	RO	SRD Rotating Stall Alarm
MAIN_SRD_diff_tgt	AV	112	Type 6	0	RO	Diffuser Target Pos
MAIN_SRD_diffault	BV	57	Type 4	0	RO	Diffuser Fault
MAIN_SRD_lift_1	AV	114	Type 6	0	RO	VDO High Lift Load Line
MAIN_SRD_lift_2	AV	115	Type 6	0	RO	VDO Low Lift Load Line
MAIN_SRD_lift_a	AV	113	Type 6	0	RO	Actual Lift
MAISURGE_act_reg	AV	96	Type 6	0	RO	Surge Region
MAISURGE_dts_act	AV	97	Type 6	0	RO	Actual Delta Tsat
MAISURGE_dts_cal	AV	98	Type 6	0	RO	Calc Ref Delta Tsat
MAISURGE_dts_maxc	AV	103	Type 6	0	RO	Cal Surge Delta Tmax
MAISURGE_dts_medc	AV	105	Type 6	0	RO	Cal Surge Delta Tsmid
MAISURGE_dts_minc	AV	104	Type 6	0	RO	Cal Surge Delta Tmin
MAISURGE_enlp_opt	AV	109	Type 6	0	RO	Envelope Line Optimized
MAISURGE_gv1_sful	AV	106	Type 6	0	RO	IGV1 Full Load Position
MAISURGE_gv1_smed	AV	108	Type 6	0	RO	Opti-Sound IGV1 Position
MAISURGE_gv1_smin	AV	107	Type 6	0	RO	IGV1 Minimum Position
MAISURGE_sc	AV	99	Type 6	0	RO	Surge Counts
MAISURGE_spc	AV	100	Type 6	0	RO	Surge Protection Counts
MAISURGE_surg_act	AV	101	Type 6	0	RO	Surge Prevention Active
MAISURGE_surg_pro	AV	102	Type 6	0	RO	Surge Protection Active
MODES_cm_stat1	MV	9	Type 5	0	RO	Comp1 Run State Val
OUTPUTS_ALE	BV	25	Type 4	0	RO	Alert Relay
OUTPUTS_ALM	BV	24	Type 4	0	RO	Alarm Relay
OUTPUTS_CHST_OUT	AV	51	Type 6	0	RO	Chiller Stat Output mA

APPENDIX D — NETWORK CONFIGURATION (CONT)

OBJECT NAME	OBJECT TYPE	INSTANCE	OPTION	COVINC	PV ACCESS	DESCRIPTION
OUTPUTS_COMP_PSV	BV	39	Type 4	0	RO	Purge Comp Valve
OUTPUTS_COMP_SR	BV	26	Type 4	0	RO	Compressor Start Relay
OUTPUTS_COND_CV	BV	34	Type 4	0	RO	Condenser Control Valve
OUTPUTS_COND_DCV	BV	37	Type 4	0	RO	Condenser Drain Valve
OUTPUTS_COND_FCV	BV	48	Type 4	0	RO	Condenser Filling Valve
OUTPUTS_COND_PSV	BV	38	Type 4	0	RO	Purge Cond Valve
OUTPUTS_DIFF_OUT	AV	49	Type 6	0	RO	Diffuser Output mA
OUTPUTS_DIS_PSV	BV	42	Type 4	0	RO	Purge Discharge Valve
OUTPUTS_DRASVON	BV	40	Type 4	0	RO	Purge Drainage Valve
OUTPUTS_ECON_IV	BV	33	Type 4	0	RO	Economizer Isolation VLV
OUTPUTS_EVAP_CV	BV	35	Type 4	0	RO	Evaporator Control Valve
OUTPUTS_EVAP_DCV	BV	36	Type 4	0	RO	Evaporator Drain Valve
OUTPUTS_EXV_OUT	AV	53	Type 6	0	RO	Oil EXV Output mA
OUTPUTS_FC_VALVE	BV	47	Type 4	0	RO	Free Cooling Valve
OUTPUTS_GV1_DEC	BV	27	Type 4	0	RO	Guide Vane 1 Decrease
OUTPUTS_GV1_INC	BV	28	Type 4	0	RO	Guide Vane 1 Increase
OUTPUTS_GV1_OUT	AV	56	Type 6	0	RO	Guide Vane1 Output
OUTPUTS_GV2_OUT	AV	57	Type 6	0	RO	Guide Vane2 Output
OUTPUTS_HDPV_OUT	AV	50	Type 6	0	RO	Head Pres Output mA
OUTPUTS_llc_exvt	AV	54	Type 6	0	RO	Liquid Level EXV Target
OUTPUTS_OIL_HEAT	BV	29	Type 4	0	RO	Oil Heater Relay
OUTPUTS_OIL_PUMP	BV	30	Type 4	0	RO	Oil Pump Relay
OUTPUTS_op_vfd_t	AV	55	Type 6	0	RO	Oil Pump VFD Target
OUTPUTS_PG_COMP	BV	44	Type 4	0	RO	Purge Compressor
OUTPUTS_PG_HEAT	BV	45	Type 4	0	RO	Purge Heater
OUTPUTS_PGAPUMP	BV	43	Type 4	0	RO	Purge Vacuum Pump
OUTPUTS_REG_PSV	BV	41	Type 4	0	RO	Purge Regeneration Valve
OUTPUTS_RUN_STAT	BV	70	Type 4	0	RO	Chiller Run Status Relay
OUTPUTS_TFR_HIGH	BV	31	Type 4	0	RO	Tower Fan Relay High
OUTPUTS_TFR_LOW	BV	32	Type 4	0	RO	Tower Fan Relay Low
OUTPUTS_VFD_OUT	AV	52	Type 6	0	RO	VFD Speed Output mA
OUTPUTS_VS_SV	BV	46	Type 4	0	RO	Vapor Source SV
POWER_I_AMPS_A_I	AV	66	Type 6	0	RO	Actual Line Current
POWER_I_AMPS_P_I	AV	67	Type 6	0	RO	Percent Line Current
POWER_I_KW	AV	70	Type 6	0	RO	Line Kilowatts
POWER_I_KWH	AV	156	Type 6	0	RO	Line Kilowatts Hours
POWER_I_In_imb_i	AV	152	Type 6	0	RO	Line Current Imbalance%
POWER_I_In_imb_v	AV	72	Type 6	0	RO	Line Voltage Imbalance%
POWER_I_POW_FACT	AV	71	Type 6	0	RO	Line Power Factor
POWER_I_VOLT_A	AV	68	Type 6	0	RO	Actual Line Voltage
POWER_I_VOLT_P	AV	69	Type 6	0	RO	Percent Line Voltage
POWER_O_alm_code	AV	84	Type 6	0	RO	VFD Alarm Code
POWER_O_amps_p_o	AV	74	Type 6	0	RO	Percent VFD Load Current
POWER_O_bus_volt	AV	76	Type 6	0	RO	DC Bus Voltage
POWER_O_enc_temp	AV	81	Type 6	0	RO	VFD Enclosure Temp
POWER_O_inv_temp	AV	82	Type 6	0	RO	Inverter Temperature
POWER_O_lrtm_sw	BV	54	Type 4	0	RO	LR Temp Switch
POWER_O_MOT_FREQ	AV	75	Type 6	0	RO	Motor Actual Frequency
POWER_O_motor_kw	AV	79	Type 6	0	RO	Motor Kilowatts
POWER_O_motor_pf	AV	78	Type 6	0	RO	Motor Power Factor
POWER_O_motorkwh	AV	80	Type 6	0	RO	Motor Kilowatt-Hours
POWER_O_prech_fd	BV	53	Type 4	0	RO	Precharge Feedback
POWER_O_rec_temp	AV	83	Type 6	0	RO	Rectifier Temperature
POWER_O_spd_fd	BV	55	Type 4	0	RO	SPD Feedback
POWER_O_vfd_act	AV	77	Type 6	0	RO	Actual VFD Speed Per
POWER_O_VFD_LOAD	AV	73	Type 6	0	RO	VFD Load Current
POWER_O_VFDC_HI	BV	56	Type 4	0	RO	High VFD Current
PRESSURE_COND_P	AV	37	Type 6	0	RO	Condenser Pressure
PRESSURE_DIFF_P	AV	40	Type 6	0	RO	Diffuser Pressure
PRESSURE_ECON_P	AV	38	Type 6	0	RO	Economizer Pressure
PRESSURE_EVAP_P	AV	36	Type 6	0	RO	Evaporator Pressure
PRESSURE_HEAD_P	AV	41	Type 6	0	RO	Head Pressure Reference
PRESSURE_OIL_PD	AV	39	Type 6	0	RO	Oil Pump Delta P

APPENDIX D — NETWORK CONFIGURATION (CONT)

OBJECT NAME	OBJECT TYPE	INSTANCE	OPTION	COVINC	PV ACCESS	DESCRIPTION
PRESSURE_PUMP_PD	AV	43	Type 6	0	RO	Ref Pump Delta P
PRESSURE_REF_PD	AV	42	Type 6	0	RO	Bearing Delta P
QCK_TEST_Q_DIFTGT	AV	111	Type 6	0	RO	Diffuser Target Pos
QCK_TEST_Q_GV1ACT	AV	110	Type 6	0	RO	Guide Vane 1 Actual Pos
RUNTIME_C_STARTS	AV	63	Type 6	0	RO	Compressor Starts Num
RUNTIME_COMP_HRS	AV	64	Type 6	0	RO	Compressor Running Hrs
RUNTIME_PGP_NO	AV	153	Type 6	0	RO	Total Pumpout Numbers
RUNTIME_PGP_TM	AV	154	Type 6	0	RO	Total Pumpout Time
RUNTIME_pgp_tm_w	AV	155	Type 6	0	RO	Avg Daily Purge in 7 Day
RUNTIME_SRV_HRS	AV	65	Type 6	0	RO	After Service Hrs
RUNTIME_ST_CNT12	AV	151	Type 6	0	RO	Starts Num in 12 Hours
SETPOINT_dem_base	AV	146	Type 6	0	RW	Base Demand Limit
SETPOINT_ecdw_sp	AV	143	Type 6	0	RW	Heating ECDW Setpoint
SETPOINT_ecw_sp	AV	141	Type 6	0	RW	Cooling ECW Setpoint
SETPOINT_EWT_OPT	BV	65	Type 4	0	RW	EWT Control Option
SETPOINT_ice_sp	AV	145	Type 6	0	RW	Ice Build Setpoint
SETPOINT_lcdw_sp	AV	144	Type 6	0	RW	Heating LCDW Setpoint
SETPOINT_icw_sp	AV	142	Type 6	0	RW	Cooling LCW Setpoint
TEMP_CBH1_T	AV	33	Type 6	0	RO	1st Stage Bearing Temp
TEMP_CBH2_T	AV	34	Type 6	0	RO	2nd Stage Bearing Temp
TEMP_cond_app	AV	17	Type 6	0	RO	Condenser Approach
TEMP_COND_SAT	AV	18	Type 6	0	RO	Cond Sat Refrig Temp
TEMP_DGT	AV	19	Type 6	0	RO	Comp Discharge Temp
TEMP_DSH	AV	20	Type 6	0	RO	Discharge Superheat
TEMP_ECDW	AV	10	Type 6	0	RO	Entering Condenser Water
TEMP_ECW	AV	8	Type 6	0	RO	Entering Chilled Water
TEMP_evap_app	AV	16	Type 6	0	RO	Evaporator Approach
TEMP_EVAP_SAT	AV	14	Type 6	0	RO	Evap Sat Refrig Temp
TEMP_EVAP_T	AV	15	Type 6	0	RO	Evap Refrig Liquid Temp
TEMP_HR_EWT	AV	12	Type 6	0	RO	Heat Recl Entering Temp
TEMP_HR_LWT	AV	13	Type 6	0	RO	Heat Recl Leaving Temp
TEMP_LCDW	AV	11	Type 6	0	RO	Leaving Condenser Water
TEMP_LCW	AV	9	Type 6	0	RO	Leaving Chilled Water
TEMP_MTRB	AV	22	Type 6	0	RO	Thrust Bearing Temp
TEMP_MTRB_OIL	AV	21	Type 6	0	RO	Thrust Bearing Oil Temp
TEMP_MTRB1	AV	23	Type 6	0	RO	Low Speed ME Brg Temp
TEMP_MTRB2	AV	24	Type 6	0	RO	Low Speed CE Brg Temp
TEMP_MTRB3	AV	25	Type 6	0	RO	High Speed ME Brg Temp
TEMP_MTRB4	AV	26	Type 6	0	RO	High Speed CE Brg Temp
TEMP_MTRW1	AV	27	Type 6	0	RO	Motor Winding 1 Temp
TEMP_MTRW2	AV	28	Type 6	0	RO	Motor Winding 2 Temp
TEMP_MTRW3	AV	29	Type 6	0	RO	Motor Winding 3 Temp
TEMP_OILT_DIS	AV	31	Type 6	0	RO	Oil Supply Temp
TEMP_OILT_SMP	AV	30	Type 6	0	RO	Oil Sump Temp
TEMP_PGC_SUCT	AV	32	Type 6	0	RO	Purge Comp Suction Temp

APPENDIX E — MODBUS CONFIGURATION

ADDRESS		REG. N°	PARAMETER	DESCRIPTION	DISPLAY MODE	TYPE	UNIT	VALUE			COMMENT
HEXADEC.	DEC.							MIN.	MAX.	DEFAULT	
0x0FA0	4000	2	GENUNIT_ctl_mode	Control Mode	32bits UINT	IR		0	3	0	
0x07D0	2000	1	GENUNIT_statstop	Deter Start Stop Command	1bit BOOL	DI		0	1	0	
0x07D1	2001	1	GENUNIT_CHIL_S_S	Network:Cmd Start/Stop	1bit BOOL	DI		0	1	0	
0x07D2	2002	1	GENUNIT_CHIL_OCC	Network:Cmd Occupied	1bit BOOL	DI		0	1	0	
0x0FA2	4002	2	GENUNIT_HC_SEL	Cooling/Heating Select	32bits UINT	IR		0	1	0	
0x0FA4	4004	2	GENUNIT_CTRL_PNT	Control Point	32bits FLOAT	IR	°F °C	10 -12.222222	160 71.111118	10 10	
0x0FA6	4006	2	GENUNIT_AMPS_P	Percent Current	32bits FLOAT	IR	%			0	
0x0FA8	4008	2	GENUNIT_KW_P	Motor Percent Kilowatts	32bits FLOAT	IR	%			0	
0x0FAA	4010	2	GENUNIT_DEM_LIM	Actual Demand Limit	32bits FLOAT	IR	%	10	100	10	
0x07D3	2003	1	GENUNIT_EMSTOP	Emergency Stop	1bit BOOL	DI		0	1	0	
0x07D4	2004	1	GENUNIT_FC_START	Start Free Cooling	1bit BOOL	DI		0	1	0	
0x0FAC	4012	2	GENUNIT_ch_state	Chiller Status Code	32bits UINT	IR				0	
0x07D5	2005	1	GENUNIT_loc_occ	Local Schedule Occupied	1bit BOOL	DI		0	1	0	
0x07D6	2006	1	GENUNIT_ice_occ	Ice Schedule Occupied	1bit BOOL	DI		0	1	0	
0x0FAE	4014	2	TEMP_ECW	Entering Chilled Water	32bits FLOAT	IR	°F °C			0 0	
0x0FB0	4016	2	TEMP_LCW	Leaving Chilled Water	32bits FLOAT	IR	°F °C			0 0	
0x0FB2	4018	2	TEMP_ECDW	Entering Condenser Water	32bits FLOAT	IR	°F °C			0 0	
0x0FB4	4020	2	TEMP_LCDW	Leaving Condenser Water	32bits FLOAT	IR	°F °C			0 0	
0x109C	4252	2	TEMP_HR_EWT	Heat Recl Entering Temp	32bits FLOAT	IR	°F °C			0 0	
0x109E	4254	2	TEMP_HR_LWT	Heat Recl Leaving Temp	32bits FLOAT	IR	°F °C			0 0	
0x0FB6	4022	2	TEMP_EVAP_SAT	Evap Sat Refrig Temp	32bits FLOAT	IR	°F °C			0 0	
0x0FB8	4024	2	TEMP_EVAP_T	Evap Refrig Liquid Temp	32bits FLOAT	IR	°F °C			0 0	
0x0FBA	4026	2	TEMP_evap_app	Evaporator Approach	32bits FLOAT	IR	°F °C			0 0	
0x0FBC	4028	2	TEMP_cond_app	Condenser Approach	32bits FLOAT	IR	°F °C			0 0	
0x0FBE	4030	2	TEMP_COND_SAT	Cond Sat Refrig Temp	32bits FLOAT	IR	°F °C			0 0	
0x0FC0	4032	2	TEMP_DGT	Comp Discharge Temp	32bits FLOAT	IR	°F °C			0 0	
0x0FC2	4034	2	TEMP_DSH	Discharge Superheat	32bits FLOAT	IR	°F °C			0 0	
0x0FC4	4036	2	TEMP_MTRB_OIL	Thrust Bearing Oil Temp	32bits FLOAT	IR	°F °C			0 0	
0x0FC6	4038	2	TEMP_MTRB	Thrust Bearing Temp	32bits FLOAT	IR	°F °C			0 0	
0x0FC8	4040	2	TEMP_MTRB1	Low Speed ME Brg Temp	32bits FLOAT	IR	°F °C			0 0	
0x0FCA	4042	2	TEMP_MTRB2	Low Speed CE Brg Temp	32bits FLOAT	IR	°F °C			0 0	
0x0FCC	4044	2	TEMP_MTRB3	High Speed ME Brg Temp	32bits FLOAT	IR	°F °C			0 0	
0x0FCE	4046	2	TEMP_MTRB4	High Speed CE Brg Temp	32bits FLOAT	IR	°F °C			0 0	
0x0FD0	4048	2	TEMP_MTRW1	Motor Winding 1 Temp	32bits FLOAT	IR	°F °C			0 0	
0x0FD2	4050	2	TEMP_MTRW2	Motor Winding 2 Temp	32bits FLOAT	IR	°F °C			0 0	
0x0FD4	4052	2	TEMP_MTRW3	Motor Winding 3 Temp	32bits FLOAT	IR	°F °C			0 0	
0x0FD6	4054	2	TEMP_CBH1_T	1st Stage Bearing Temp	32bits FLOAT	IR	°F °C			0 0	
0x0FD8	4056	2	TEMP_CBH2_T	2nd Stage Bearing Temp	32bits FLOAT	IR	°F °C			0 0	
0x0FDC	4060	2	TEMP_OILT_SMP	Oil Sump Temp	32bits FLOAT	IR	°F °C			0 0	
0x0FDE	4062	2	TEMP_OILT_DIS	Oil Supply Temp	32bits FLOAT	IR	°F °C			0 0	
0x0FE0	4064	2	TEMP_PGC_SUCT	Purge Comp Suction Temp	32bits FLOAT	IR	°F °C			0 0	
0x0FE4	4068	2	PRESSURE_EVAP_P	Evaporator Pressure	32bits FLOAT	IR	psig kPa			0 0	
0x0FE6	4070	2	PRESSURE_COND_P	Condenser Pressure	32bits FLOAT	IR	psig kPa			0 0	
0x0FE8	4072	2	PRESSURE_ECON_P	Economizer Pressure	32bits FLOAT	IR	psig kPa			0 0	
0x0FEA	4074	2	PRESSURE_OIL_PD	Oil Pump Delta P	32bits FLOAT	IR	psig kPa			0 0	

APPENDIX E — MODBUS CONFIGURATION (CONT)

ADDRESS		REG. N°	PARAMETER	DESCRIPTION	DISPLAY MODE	TYPE	UNIT	VALUE			COMMENT
HEXADEC.	DEC.							MIN.	MAX.	DEFAULT	
0x0FEC	4076	2	PRESSURE_REF_PD	Bearing Delta P	32bits FLOAT	IR	psig kPa			0 0	
0x0FEE	4078	2	PRESSURE_PUMP_PD	Ref Pump Delta P	32bits FLOAT	IR	psig kPa			0 0	
0x0FF0	4080	2	PRESSURE_DIFF_P	Diffuser Pressure	32bits FLOAT	IR	psig kPa			0 0	
0x0FF2	4082	2	PRESSURE_HEAD_P	Head Pressure Reference	32bits FLOAT	IR	psig kPa			0 0	
0x07D7	2007	1	INPUTS_STAR_AUX	Compressor Start Contact	1bit BOOL	DI		0	1	0	
0x0FF4	4084	2	INPUTS_DMP_ACT	Damper Valve Status	32bits UINT	IR				0	
0x0FF6	4086	2	INPUTS_HGBP_ACT	EC Valve Status	32bits UINT	IR				0	
0x07D8	2008	1	INPUTS_HP_SW	High Pressure Switch	1bit BOOL	DI		0	1	0	
0x07D9	2009	1	INPUTS_REM_CON	Remote Contact	1bit BOOL	DI		0	1	0	
0x07DA	2010	1	INPUTS_E_STOP	Emergency Stop Contact	1bit BOOL	DI		0	1	0	
0x07DB	2011	1	INPUTS_ICE_CON	Ice Build Contact	1bit BOOL	DI		0	1	0	
0x07DC	2012	1	INPUTS_REM_LOCK	Chiller Lockout	1bit BOOL	DI		0	1	0	
0x07DD	2013	1	INPUTS_SAFETY	Spare Safety Input	1bit BOOL	DI		0	1	0	
0x07DE	2014	1	INPUTS_STARTFLT	Starter Fault Feedback	1bit BOOL	DI		0	1	0	
0x07DF	2015	1	INPUTS_FS_LOCK	Fire Security Interlock	1bit BOOL	DI		0	1	0	
0x0FF8	4088	2	INPUTS_HGBPACTP	Actual ECV Pos Per	32bits FLOAT	IR	%			0	
0x0FFC	4092	2	INPUTS_GV1_ACT	Guide Vane 1 Actual Pos	32bits FLOAT	IR	%			0	
0x0FFE	4094	2	INPUTS_GV2_ACT	Guide Vane 2 Actual Pos	32bits FLOAT	IR	%			0	
0x1000	4096	2	INPUTS_VFD_ACT	Actual VFD Speed Per	32bits FLOAT	IR	%			0	
0x07E2	2018	1	INPUTS_TRIPR	ISM Trip Relay Status	1bit BOOL	DI		0	1	0	
0x1002	4098	2	OUTPUTS_CHST_OUT	Chiller Stat Output mA	32bits FLOAT	IR	mA			0	
0x1004	4100	2	OUTPUTS_exv_tgt	Oil EXV Target	32bits FLOAT	IR	%			0	
0x1008	4104	2	OUTPUTS_hdpv_tgt	Head Pres Valve Tgt Pos	32bits FLOAT	IR	%			0	
0x07E3	2019	1	OUTPUTS_ALM	Alarm Relay	1bit BOOL	DI		0	1	0	
0x07E4	2020	1	OUTPUTS_ALE	Alert Relay	1bit BOOL	DI		0	1	0	
0x07E5	2021	1	OUTPUTS_COMP_SR	Compressor Start Relay	1bit BOOL	DI		0	1	0	
0x07E6	2022	1	OUTPUTS_GV1_DEC	Guide Vane 1 Decrease	1bit BOOL	DI		0	1	0	
0x07E7	2023	1	OUTPUTS_GV1_INC	Guide Vane 1 Increase	1bit BOOL	DI		0	1	0	
0x07E8	2024	1	OUTPUTS_OIL_HEAT	Oil Heater Relay	1bit BOOL	DI		0	1	0	
0x07E9	2025	1	OUTPUTS_OIL_PUMP	Oil Pump Relay	1bit BOOL	DI		0	1	0	
0x07EA	2026	1	OUTPUTS_TFR_HIGH	Tower Fan Relay High	1bit BOOL	DI		0	1	0	
0x07EB	2027	1	OUTPUTS_TFR_LOW	Tower Fan Relay Low	1bit BOOL	DI		0	1	0	
0x07EF	2031	1	OUTPUTS_COND_PSV	Purge Cond Valve	1bit BOOL	DI		0	1	0	
0x07F0	2032	1	OUTPUTS_COMP_PSV	Purge Comp Valve	1bit BOOL	DI		0	1	0	
0x07F1	2033	1	OUTPUTS_PUMP_PSV	Purge Pumpout Valve	1bit BOOL	DI		0	1	0	
0x07F3	2035	1	OUTPUTS_REG_PSV	Purge Regeneration Valve	1bit BOOL	DI		0	1	0	
0x07F4	2036	1	OUTPUTS_DIS_PSV	Purge Discharge Valve	1bit BOOL	DI		0	1	0	
0x07F5	2037	1	OUTPUTS_PGAPUMP	Purge Vacuum Pump	1bit BOOL	DI		0	1	0	
0x07F6	2038	1	OUTPUTS_PG_COMP	Purge Compressor	1bit BOOL	DI		0	1	0	
0x07F7	2039	1	OUTPUTS_PG_HEAT	Purge Heater	1bit BOOL	DI		0	1	0	
0x100A	4106	2	OUTPUTS_llc_exvt	Liquid Level EXV Target	32bits FLOAT	IR	%			0	
0x07F8	2040	1	OUTPUTS_FC_VALVE	Free Cooling Valve	1bit BOOL	DI		0	1	0	
0x100E	4110	2	OUTPUTS_HGBP_OUT	EC Valve Output mA	32bits FLOAT	IR	mA			0	
0x07F9	2041	1	HYDRLIC_CDWP	Condenser Water Pump	1bit BOOL	DI		0	1	0	
0x1010	4112	2	HYDRLIC_cdw_pd	Condenser Water Delta P	32bits FLOAT	IR	psig kPa			0 0	
0x07FA	2042	1	HYDRLIC_CHWP	Chilled Water Pump	1bit BOOL	DI		0	1	0	
0x1012	4114	2	HYDRLIC_chw_pd	Chilled Water Delta P	32bits FLOAT	IR	psig kPa			0 0	
0x1014	4116	2	HYDRLIC_CDWP_FV	Cond Water Flow Value	32bits FLOAT	IR	gpm l/min			0 0	
0x1016	4118	2	HYDRLIC_CHWP_FV	Chilled Water Flow Value	32bits FLOAT	IR	gpm l/min			0 0	
0x1018	4120	2	RUNTIME_C_STARTS	Compressor Starts Num	32bits UINT	IR				0	
0x101A	4122	2	RUNTIME_SRV_HRS	After Service Hrs	32bits FLOAT	IR	hours	0	500000	0	
0x1096	4246	2	RUNTIME_ST_CNT12	Starts Num in 12 Hours	32bits UINT	IR				0	
0x1090	4240	2	RUNTIME_PGP_NO	Total Pumpout Numbers	32bits UINT	IR				0	
0x1092	4242	2	RUNTIME_PGP_TM	Total Pumpout Time	32bits UINT	IR	minutes			0	
0x1094	4244	2	RUNTIME_pgp_tm_w	Avg Daily Purge in 7 Day	32bits FLOAT	IR	minutes			0	
0x101C	4124	2	ALARMRST_alarm_1	Jbus Current Alarm 1	32bits UINT	IR				0	
0x101E	4126	2	ALARMRST_alarm_2	Jbus Current Alarm 2	32bits UINT	IR				0	
0x1020	4128	2	ALARMRST_alarm_3	Jbus Current Alarm 3	32bits UINT	IR				0	
0x1022	4130	2	ALARMRST_alarm_4	Jbus Current Alarm 4	32bits UINT	IR				0	
0x1024	4132	2	ALARMRST_alarm_5	Jbus Current Alarm 5	32bits UINT	IR				0	
0x1026	4134	2	CAPACTRL_ctrl_wt	Controlled Water Temp	32bits FLOAT	IR	°F °C			0 0	
0x1028	4136	2	CAPACTRL_cm_stat1	Comp1 Run State Val	32bits UINT	IR				0	

APPENDIX E — MODBUS CONFIGURATION (CONT)

ADDRESS		REG. N°	PARAMETER	DESCRIPTION	DISPLAY MODE	TYPE	UNIT	VALUE			COMMENT
HEXADEC.	DEC.							MIN.	MAX.	DEFAULT	
0x102A	4138	2	CAPACTRL_vfd_tgt	Target VFD Speed Per	32bits FLOAT	IR	%			0	
0x102C	4140	2	CAPACTRL_gv1_tgt	Target GV1 Pos	32bits FLOAT	IR	%			0	
0x102E	4142	2	CAPACTRL_gv2_tgt	Target GV2 Pos	32bits FLOAT	IR	%			0	
0x1030	4144	2	CAPACTRL_hgbp_tp	ECV Target Percent	32bits FLOAT	IR	%			0	
0x1032	4146	2	MAISURGE_act_reg	Surge Region	32bits UINT	IR				0	
0x1034	4148	2	MAISURGE_sc	Surge Counts	32bits UINT	IR				0	
0x1036	4150	2	MAISURGE_surg_act	Surge Prevention Active	32bits UINT	IR		0	1	0	
0x1038	4152	2	MAISURGE_spc	Surge Protection Counts	32bits UINT	IR				0	
0x103A	4154	2	MAISURGE_surg_pro	Surge Protection Active	32bits UINT	IR		0	1	0	
0x103C	4156	2	MAISURGE_dts_act	Actual Delta Tsat	32bits FLOAT	IR	^F ^C			0 0	
0x103E	4158	2	MAISURGE_dts_cal	Calc Ref Delta Tsat	32bits FLOAT	IR	^F ^C			0 0	
0x1040	4160	2	MAIN_SRD_diff_tgt	Diffuser Target Pos	32bits FLOAT	IR	%			0	
0x07FB	2043	1	MAIN_SRD_diffault	Diffuser Fault	1bit BOOL	DI		0	1	0	
0x07FC	2044	1	MAIN_SRD_diff_alm	SRD Rotating Stall Alarm	1bit BOOL	DI		0	1	0	
0x1042	4162	2	MAIN_SRD_lift_a	Actual Lift	32bits FLOAT	IR	^F ^C			0 0	
0x1044	4164	2	MAIN_SRD_lift_1	VDO High Lift Load Line	32bits FLOAT	IR	^F ^C			0 0	
0x1046	4166	2	MAIN_SRD_lift_2	VDO Low Lift Load Line	32bits FLOAT	IR	^F ^C			0 0	
0x1048	4168	2	POWER_I_AMPS_A_I	Actual Line Current	32bits FLOAT	IR	A			0	
0x104A	4170	2	POWER_I_AMPS_P_I	Percent Line Current	32bits FLOAT	IR	%			0	
0x104C	4172	2	POWER_I_VOLT_A	Actual Line Voltage	32bits FLOAT	IR	V			0	
0x104E	4174	2	POWER_I_VOLT_P	Percent Line Voltage	32bits FLOAT	IR	%			0	
0x1050	4176	2	POWER_I_KW	Line Kilowatts	32bits FLOAT	IR	kW			0	
0x1052	4178	2	POWER_I_POW_FACT	Line Power Factor	32bits FLOAT	IR				0	
0x1098	4248	2	POWER_I_In_imb_v	Line Voltage Imbalance%	32bits FLOAT	IR	%			0	
0x109A	4250	2	POWER_I_In_imb_i	Line Current Imbalance%	32bits FLOAT	IR	%			0	
0x1054	4180	2	POWER_O_MOT_FREQ	Motor Actual Frequency	32bits FLOAT	IR	Hz			0	
0x1056	4182	2	POWER_O_VFD_LOAD	VFD Load Current	32bits FLOAT	IR	A			0	
0x1058	4184	2	POWER_O_amps_p_o	Percent VFD Load Current	32bits FLOAT	IR	%			0	
0x105A	4186	2	POWER_O_bus_volt	DC Bus Voltage	32bits FLOAT	IR	V			0	
0x105C	4188	2	POWER_O_vfd_act	Actual VFD Speed Per	32bits FLOAT	IR	%			0	
0x105E	4190	2	POWER_O_motor_pf	Motor Power Factor	32bits FLOAT	IR				0	
0x1060	4192	2	POWER_O_motor_kw	Motor Kilowatts	32bits FLOAT	IR	kW			0	
0x1062	4194	2	POWER_O_motorkwh	Motor Kilowatt-Hours	32bits FLOAT	IR	kWh			0	
0x1064	4196	2	POWER_O_enc_temp	VFD Enclosure Temp	32bits FLOAT	IR	°F °C			0 0	
0x1066	4198	2	POWER_O_inv_temp	Inverter Temperature	32bits FLOAT	IR	°F °C			0 0	
0x1068	4200	2	POWER_O_rec_temp	Rectifier Temperature	32bits FLOAT	IR	°F °C			0 0	
0x07FD	2045	1	POWER_O_VFDC_HI	High VFD Current	1bit BOOL	DI		0	1	0	
0x07FE	2046	1	POWER_O_prech_fd	Precharge Feedback	1bit BOOL	DI		0	1	0	
0x07FF	2047	1	POWER_O_lrtem_sw	LR Temp Switch	1bit BOOL	DI		0	1	0	
0x106A	4202	2	POWER_O_alm_code	VFD Alarm Code	32bits UINT	IR				0	
0x0800	2048	1	POWER_O_spd_fd	SPD Feedback	1bit BOOL	DI		0	1	0	
0x0801	2049	1	LABONLY_gv1_fc	GV1 Forced	1bit BOOL	DI		0	1	0	
0x0802	2050	1	LABONLY_gv2_fc	GV2 Forced	1bit BOOL	DI		0	1	0	
0x106C	4204	2	MAIN_MS_lead_lag	Unit is Lead or Lag	32bits UINT	IR		0	2	0	
0x0803	2051	1	MAIN_MS_ll_comm	Lead Lag Communication	1bit BOOL	DI		0	1	0	
0x106E	4206	2	MAIN_MS_ll_fault	Master Slave Fault	32bits UINT	IR		0	3	0	
0x1070	4208	2	MAIN_MS_lagstat	Slave Run Status	32bits UINT	IR		0	14	0	
0x0804	2052	1	MAIN_MS_lag_s_s	Slave Start/Stop	1bit BOOL	DI		0	1	0	
0x1072	4210	2	MAIN_MS_lagstart	Lag Start Timer	32bits FLOAT	IR	minutes	0	60	0	
0x1074	4212	2	MAIN_MS_lagstop	Lag Stop Timer	32bits FLOAT	IR	minutes	0	60	0	
0x1076	4214	2	MAIN_MS_prefft	Prestart Fault Timer	32bits FLOAT	IR	minutes	0	30	0	
0x1078	4216	2	MAIN_MS_pulltime	Pulldown Timer	32bits FLOAT	IR	minutes	0	30	0	
0x107A	4218	2	MAIN_MS_ll_hr_d	Lead/Lag Hours Delta	32bits FLOAT	IR	hours	-99999	99999	0	
0x107C	4220	2	CONF_OPT_hgbp_opt	EC Valve Option	32bits UINT	IR		0	3	0	
0x107E	4222	2	CONF_OPT_hgbp_sel	EC Valve Selection	32bits UINT	IR		0	3	0	
0x0805	2053	1	CONNECT_bacena	BACnet/IP Enable	1bit BOOL	DI		0	1	0	
0x0806	2054	1	CONNECT_bacunit	BACnet Metric Unit	1bit BOOL	DI		0	1	0	
0x1080	4224	2	CONNECT_network	BACnet Network	32bits FLOAT	IR		1	9999	1600	
0x1082	4226	2	CONNECT_bac_id	BACnet Identifier	32bits FLOAT	IR		0	9999999	1600001	
0x1088	4232	2	CONF_PRG_oil_qly	Oil Quality	32bits UINT	IR		0	2	0	
0x108A	4234	2	CONF_PRG_oilflt	Oil Filter Failure	32bits UINT	IR		0	2	0	
0x108C	4236	2	CONF_PRG_tran_dev	Transducer Deviation	32bits UINT	IR		0	2	0	

APPENDIX E — MODBUS CONFIGURATION (CONT)

ADDRESS		REG. N°	PARAMETER	DESCRIPTION	DISPLAY MODE	TYPE	UNIT	VALUE			COMMENT
HEXADEC.	DEC.							MIN.	MAX.	DEFAULT	
0x108E	4238	2	CONF_PRG_ref_chg	Refrig Charge Status	32bits UINT	IR		0	2	0	
0x10A0	4256	2	POWER_I_KWH	Line Kilowatts Hours	32bits FLOAT	IR	KWH			0	
0x0BB8	3000	2	SETPOINT_ecdw_sp	Heating ECDW Setpoint	32bits FLOAT	HR	°F °C	63 17.2222248	150 65.555562	104 104	
0x0BBA	3002	2	SETPOINT_ecw_sp	Cooling ECW Setpoint		HR	°F °C	15 -9.444444	120 48.888894	60 60	
0x0BBC	3004	2	SETPOINT_ice_sp	Ice Build Setpoint	32bits FLOAT	HR	°F °C	15 -9.444444	60 15.555558	40 40	
0x0BBE	3006	2	SETPOINT_lcdw_sp	Heating LCDW Setpoint	32bits FLOAT	HR	°F °C	68 20.0000028	150 65.555562	113 113	
0x0BC0	3008	2	SETPOINT_lcw_sp	Cooling LCW Setpoint	32bits FLOAT	HR	°F °C	10 -12.222222	120 48.888894	45 45	
0x0BC2	3010	2	SETPOINT_dem_base	Base Demand Limit	32bits FLOAT	HR	%	10	100	100	
0x0BC4	3012	2	SETPOINT_EWT_OPT	EWT Control Option	32bits UINT	HR		0	1	0	
0x0BC6	3014	2	PROTOCOL_CHIL_S_S	Chiller Start/Stop	32bits UINT	HR		0	1	0	
0x0BC8	3016	2	PROTOCOL_CTRL_PNT	Control Point	32bits FLOAT	HR	°F °C	10 -12.222222	160 71.111118	50 50	
0x0BCA	3018	2	PROTOCOL_DEM_LIM	Demand Limit	32bits FLOAT	HR	%	10	100	10	
0x0BCC	3020	2	PROTOCOL_EMSTOP	Emergency Stop	32bits UINT	HR		0	1	0	
0x0BCE	3022	2	PROTOCOL_HC_SEL	Heatcool Select	32bits UINT	HR		0	1	0	
0x0BD0	3024	2	PROTOCOL_CHIL_OCC	Chiller occupied?	32bits UINT	HR		0	1	0	
0x0BD2	3026	2	GENUNIT_REM_RST	Remote Reset Alarm	32bits UINT	HR		0	1	0	
0x0BD4	3028	2	PROTOCOL_FC_START	Start Free Cooling	32bits UINT	HR		0	1	0	
0x0807	2055	1	OUTPUTS_RUN_STAT	Chiller Run Status Relay	1bit BOOL	DI		0	1	0	

LEGEND

CO	—	COILS_MEDIA
DEC	—	Decimal
DI	—	DISCR_INPUT_MEDIA
HEXIDEC	—	Hexadecimal
HR	—	HOLDING_REG_MEDIA
IR	—	INPUT_REG_MEDIA

