

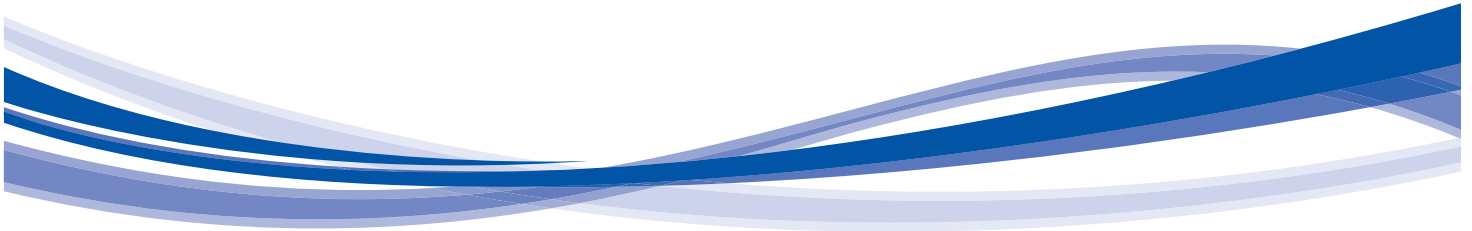

Product Data

WeatherExpert® Packaged Rooftop Units

75 to 150 Nominal Tons



48/50N2,N3,N4,N5,N6,N7,N8,N9
Packaged Rooftop Cooling Units with Gas Heat, Optional
Electric Heat or Hydronic Heat, and ComfortLink Controls

Carrier's 48/50N units offer performance, innovation, and reliability.

Carrier's 48/50N Series commercial packaged rooftops offer:

- Puron® refrigerant (R-410A)
- multiple efficiency and capacity choices
- electronic expansion valves
- double wall foam panel construction
- mixed air and final filter options
- flexible blank section and plenum options
- non-overloading airfoil supply fan
- *ComfortLink* DDC (Direct Digital Controls) controller with Navigator™ user interface
- Carrier Comfort Network (CCN) communication with optional BACnet¹ (option), Modbus² (accessory), or LonWorks³ (accessory) capability. Requires option/accessory
- Novation® heat exchanger technology with microchannel coil
- scroll compressors with digital compressor option
- full capacity operation at 125°F, operation to 32°F, optionally to -20°F
- constant volume (CV)
- staged air volume (SAV™)
- variable air volume (VAV)
- Humidi-MiZer® adaptive dehumidification option
- vertical, horizontal, or mixed supply/return configurations
- optional return fan or modulating power exhaust
- gas heat with optional modulating control
- electric heat with optional SCR (silicon-controlled rectifier) control
- hydronic heat option

Key components of the package provide design flexibility, quality, and interoperability.

Design flexibility

The 48/50N Series rooftop units with *ComfortLink* controls are designed to meet all customer requirements for new construction, replacement jobs, or special applications.

Customers choose from the following:

- standard or high efficiency options

1. BACnet is a registered trademark of ASHRAE (American Society of Heating, Refrigerating, and Air-Conditioning Engineers).
 2. Modbus is a registered trademark of Schneider Electric.
 3. LonWorks is a registered trademark of Echelon Corporation.

- CV, SAV™, or VAV applications
- double wall foam panel construction with optional Agion⁴ interior
- optional digital scroll compressors
- supply-fan motor sizes from 15 to 100 hp
- open drip proof (ODP) or totally enclosed fan-cooled (TEFC) motors
- up to 4 sizes of natural gas heat with optional modulating control (48 Series units)
- 3 sizes of electric heat with optional SCR (silicon-controlled rectifier) control (50 Series units)
- hydronic heat with modulating control (50 Series units)
- microchannel heat exchanger (MCHX) condenser coils or e-coated MCHX condenser coils
- integrated economizer with ultra low-leak dampers per AMCA (Air Movement and Control Association) Std 500
- modulating power exhaust or return fan
- optional low outdoor sound configuration
- mixed air and final filter options including pleated, bag, cartridge, and HEPA (high efficiency particulate air)
- Humidi-MiZer® adaptive dehumidification system
- optional auxiliary coil section or blank sections in 4 or 8 ft lengths

Supply/return configurations

The units may be provided with vertical or horizontal supply, vertical or horizontal return, in any combination; e.g., horizontal supply with vertical return.

Exhaust and return options

Superior space pressure control is provided by specifying one of the modulating exhaust systems. Modulating exhaust systems use a variable frequency drive (VFD) to control exhaust fan airflow rates to maintain a user-established space pressure set point. The exhaust options include high and low static choices with a wide range of motor horsepower available. For applications with ducted returns that have significant duct static pressures, an optional return fan and building pressure control exhaust system is available. The return fan provides a separate fan system dedicated to overcoming flow losses in the return duct, thus reducing the total selection load on the unit's supply fan. The return fan includes a VFD which modulates return fan airflow to match supply fan airflow and provide high exhaust flow rate. The return fan option is available in high and low static choices.

Efficiency/capacity options

The customer is given the opportunity to select the unit configuration that most closely matches the application requirements. Standard efficiency units offer efficiency levels that exceed ASHRAE 90.1 requirements and will meet the needs of many applications.

Table of contents

	Page
Features/Benefits	2
Model Number Nomenclature	8
Ratings and Capacities	10
Physical Data	13
Options and Accessories	24
Base Unit Dimensions	31
Accessory Dimensions	39
Performance Data	43
Electrical Data	45
Controls	46
Application Data	55
Typical Piping and Wiring	59
Typical Wiring Schematics	60
Guide Specifications	75

4. Agion is a trademark of Sciesent.

For the energy-conscious customer, the high-efficiency units provide efficiency levels that meet or exceed the Consortium for Energy Efficiency (CEE). Standard and high capacity options allow the user to select the capacity combination most appropriate for the application.

The ability to select efficiency and capacity levels will provide up to four different unit combinations in each unit size. In addition, all motors are premium efficiency designs and are VFD controlled to optimize energy usage.

Environmentally balanced

Carrier's Puron® refrigerant (R-410A) is a responsible choice for protecting the earth's ozone layer. Puron refrigerant is an HFC refrigerant that does not contain chlorine that is damaging to the ozone layer. Puron refrigerant is a safe, efficient, and environmentally balanced refrigerant.

Quality and reliability

The unit cabinet is constructed of double wall foam panels for the sides, floor, and ceiling of the airside section. The foam panels provide excellent insulating properties, structural rigidity, and easily cleaned surfaces. The entire unit is supported on roll-formed, high-strength steel base rails. These rails offer a stable base for the rooftop units' various components; e.g., compressors, coils, and side panels. In addition, the continuous rail design provides a strong lifting platform to allow easy placement of even the largest units.

Performance

Excellent full and part load efficiencies are achieved by using multiple scroll compressors and indoor coils with intertwined dual refrigerant circuits. Enhanced refrigerant control is achieved through the use of electronic expansion valves (EXVs). This enhanced control allows maximum use of the Puron refrigerant (R-410A) and contributes to improved efficiency. The compressors are equipped with crankcase heaters and protected by electronic sensors and logic to control minimum on and off times and reverse rotation. The refrigerant circuits are both electrically and mechanically independent to provide standby capability, should one circuit require service.

Novation® heat exchanger technology

The Novation heat exchanger design, with microchannel condenser coil, is a robust, cost effective alternative to traditional coil design for standard applications. Due to the compact all-aluminum design, microchannel coils reduce overall unit operating weight.

The streamlined microchannel coil also reduces refrigerant charge by up to 40% vs. conventional coil design, additionally aiding in LEED¹ design projects. Microchannel coils are not recommended by Carrier for marine, coastal, or industrial environments, unless a Carrier-approved coating is applied.

Airfoil supply fan

The supply fan is a single wheel of the double width double inlet (DWDI) airfoil type. The airfoil design is a non-overloading type and is the highest efficiency of all the centrifugal fan types. In each unit size there are two supply fan options available. The standard fan will meet the static requirements of most applications. For buildings with lengthy and/or complex duct designs, a high-static airfoil fan option is available. Another consideration in selecting the supply fan was the amount of additional pressure capability that is required on highly featured rooftops. As a result, the selected fans were sized to provide the required external static pressure even when the rooftop unit is fully loaded with options. In short, the DWDI airfoil fans were selected to provide maximum efficiency in the 48/50N rooftop, taking into consideration the effect of the entire system.

Digital scroll compressor

In air conditioning applications, the load may vary significantly, requiring a means to vary the system capacity for optimal system performance and control. The WeatherExpert Series' large rooftop units, with digital scroll compression, provide a highly efficient means of capacity control using scroll compressors. The digital compressor technology provides smooth, vibration-free operation by axially unloading the compliant scrolls. By varying the amount of time that the scrolls are unloaded, the N Series unit is able to precisely match the system capacity to the space load. This feature can reduce energy consumption, provide better dehumidification, reduce compressor cycling, and improve comfort in the space.

ComfortLink controls

Factory-installed *ComfortLink* controls provide capability for free-standing operation or may be linked with a more extensive system. Optional factory-installed and programmed BACnet communication capability provides simple integration with the building HVAC system (e.g., terminal devices), an i-Vu®

Open control system, or a BACnet building automation system. *ComfortLink* controls also have the capability to communicate with the Carrier Comfort Network® (CCN) system. The 48/50N Series may also be configured to communicate via Modbus or LonWorks protocols. This communication flexibility allows simple system integration as well as data collection, trending, monitoring, and alarm displays.

A self-diagnostic microprocessor manages all unit sequences, including stages of cooling and unit safety controls. At start-up, the self-diagnostic test verifies component operation and calibration. Fault codes and expanded fault descriptions reduce service troubleshooting time and difficulty.

The *ComfortLink* controls can also interface directly with Carrier Open or CCN controls on 35 and 45 Series VAV terminals to form a system for optimal efficiency and tenant comfort. All units may also be applied to non-communicating building control systems via switch and/or 4 to 20 mA signal to provide remote occupancy control, fire shutdown and smoke control modes, IAQ (indoor air quality) modes, and demand limit sequences. In addition, VAV units can interface with other control systems via a 4 to 20 mA signal capability which permits control of supply-air temperature reset.

Standard *ComfortLink* controls functions include:

- easy-to-use, plain English Navigator™ user interface module with a 4 x 24 character backlit LCD display
- supply-fan control, based on occupancy schedule
- up to 8 steps of capacity control with standard scroll compressors
- digital scroll compressor option for variable control of compressor capacity to precisely match the load requirement of the space
- lead-lag circuit control to equalize the operating hours between the dual refrigeration circuits
- 2-stage or modulating heat control
- adaptive optimal start/morning warm-up
- adaptive optimal stop (CV only)
- head pressure control to 32°F ambient outdoor-air temperature
- economizer and ventilation control
- economizer sequence enabled by standard outside air enthalpy switch
- filter maintenance alarm
- adjustment of space set point in the occupied space on CV and SAV applications

1. LEED is a registered trademark of the U.S. Green Building Council.

- selectable supply air set point in CV, SAV, and VAV modes
- control of variable frequency drives on supply, power exhaust, and return fan motors
- interface with 35 or 45 Series VAV terminals for a complete system
- IAQ and demand-controlled ventilation control support
- space temperature reset (VAV applications)
- local or remote unit alarm and alert monitoring
- building ventilation mode purge
- self-monitoring diagnostics
- demand limiting
- external input to permit supply-air temperature reset using a 4 to 20 mA signal

Unique design

A unique feature of these units with *ComfortLink* controls is support for CV, SAV, and VAV unit operations. The controls are configured in the factory, based on the unit model and options installed. A reset feature is included that allows the technician to easily reset the *ComfortLink* configurations to the factory settings. System functions like adaptive optimal start, nighttime free cooling, building smoke control modes, occupied heating, and IAQ support are resident in the controls and can be easily integrated into the control system strategy.

Electronic expansion valves

The electronic expansion valves (EXVs) provide precise refrigerant control to the evaporators. This maximizes the efficiency of the refrigeration system and minimizes energy consumption.

Fan modulation

The *ComfortLink* controller maintains supply duct pressure on VAV models by monitoring the factory-installed duct pressure transducer. The VFD varies the supply fan airflow to maintain the user-established duct pressure set point in the supply duct.

Humidi-MiZer® adaptive dehumidification system

Carrier's Humidi-MiZer adaptive dehumidification system is an all-inclusive factory-installed option that can be ordered with any WeatherExpert® 48/50N Series rooftop unit. This system expands the envelope of operation of the N Series rooftop to provide unprecedented flexibility that will meet year-round comfort conditions. The WeatherExpert N Series next generation version of Carrier's Humidi-MiZer system includes modulating refrigerant valves

that provide variable flow bypass around the condenser. This innovative feature ensures exact control of the supply-air temperature as the unit lowers the evaporator temperature to increase latent capacity. The evaporator discharge temperature and the supply air temperature set points may be configured in the *ComfortLink* controller to meet the specific requirements of the application.

The Humidi-MiZer adaptive dehumidification system has the industry's only dual dehumidification mode setting. The WeatherExpert rooftop, coupled with the Humidi-MiZer adaptive dehumidification system, is capable of operating in normal design cooling mode, sub-cooling mode, and hot gas reheat mode.

In the normal design cooling mode the unit will operate under the normal sequence of operation; e.g., the *ComfortLink* system may control the evaporator discharge temperature to 55°F. The Humidi-MiZer system is inactive.

In the sub-cooling mode the *ComfortLink* controller will control the refrigeration system to satisfy cooling and dehumidification requirements, as well as providing adequate reheat to maintain the desired supply-air temperature.

Hot gas reheat mode will operate when the space requires dehumidification only. The *ComfortLink* controller will control the refrigeration system to provide latent capacity similar to that provided in the full sub-cooling mode. In addition, it can increase hot discharge gas bypass to the Humidi-MiZer coil in order to heat the air to the exact neutral state required—no overcooling or overheating.

Supply air tempering

Modulating gas heat control and SCR electric heat control options provide a supply air tempering heat function during conditions of low, mixed air temperature while the system is in the Ventilation mode. These low, mixed air conditions occur when the outdoor temperature is low and the outside-air damper is in its minimum position, so that the mixing of cold outside air and return air results in mixed-air temperatures below 50°F. Both modulating gas control and SCR electric heat options will raise the air temperature leaving the unit up to the tempering mode set point.

VAV solution

The 48/50N *ComfortLink* control fully supports VAV applications. Carrier's complete offering of single duct and fan-powered mixing boxes utilize a unique control system which uses linkage to

exchange data between the zone terminals and their air source to form a coordinated HVAC system. The system's air source controller, zone controllers, and bypass controller (if applicable) are linked so that their data exchange can be managed by one zone controller configured as the Master.

The VAV Master continuously scans the system and gathers the following information from each zone:

- Set points and zone temperature
- Zone size
- Occupancy status
- Damper position
- RH (Relative Humidity) and CO₂ values (if applicable)

The Master then performs calculations and sends the results to the air source. Examples:

- If any zone is occupied, the system's occupancy status is set to occupied.
- If the system is occupied, the Master averages the space temperatures from all occupied zones using their normal terminal size at 1 in. velocity pressure to apply a weighting factor to that average (OCCSPT).
- The Master calculates weighted average set points for heating and cooling in occupied and unoccupied modes.
- If the zones supply CO₂ or RH values, the Master calculates either a maximum or average value as determined by the configuration for each.

The air source determines the operating mode from the information received, and then sends the following to the Master:

- Air source mode
- Supply-air temperature
- Outside-air temperature
- Static pressure (if applicable)

By constantly monitoring individual zones and performing numerous calculations, the Master is able to optimize the system to appropriately meet demands at the zone level instead of building-wide. Energy savings are achieved through system optimization and control, eliminating wasteful energy losses throughout the building from over-treating air. For more information on Linkage and Carrier's zoning products, see the Air Terminal and Controls product literature.

Indoor air quality (IAQ)

Double wall foam panel construction in the airstream is standard on the 48/50N Series. This design provides an easy to clean interior surface and eliminates the risk of insulation particles in the supply

airstream. Double wall construction with Agion anti-microbial coating is also available as a special order. All units incorporate a double-sloped, stainless steel condensate drain pan to prevent standing water from accumulating inside the rooftop air-conditioning unit. The condensate pan has a recessed nonferrous condensate drain connection. These units and controls have been developed to provide the design community with the flexibility to meet individual job needs for both comfort and IAQ. The basic unit features include:

- optional economizers capable of handling up to 100% outdoor air
- integrated economizer operation to minimize mechanical cooling
- intertwined refrigeration circuits for optimum performance at part load operation
- dual circuits with scroll compressors on each circuit for reliability and efficiency
- CV and SAV units to provide multi-stage cooling capacity control based on thermostat or space sensor input
- VAV units to provide multi-stage cooling capacity control for improved part load operation and greater efficiency
- optional digital compressors to provide a nearly infinite number of steps of capacity for unmatched load matching and part load performance
- Humidi-MiZer adaptive dehumidification system
- refrigeration system designed to operate with outdoor temperatures down to 32°F, optionally to -20°F.

Filtration

The filter options include mixed air and final filter choices. The MERV (minimum efficiency reporting value) ratings range from a MERV 8 to a MERV 17 HEPA (high efficiency particulate air) type. The filters are snug fitting in a rigid track with seals that limit air leakage around the filters. The standard factory 2-in. mixed air filter rack can be easily field converted into a 4-in. filter rack.

Installation and serviceability

Access panels

All full-size access panels are hinged for easy access to serviceable components. No fasteners need to be removed to open the hinged panels. This reduces service time and prevents roof leaks caused by discarded screws puncturing the roof.

Electrical connections

Single point electrical connection is standard on all units. Electrical service access can be made through roof curb or side of unit. All 48N units provide a single point gas connection.

Run testing

To ensure a successful start-up, every rooftop unit is factory run tested.

Unit design

Unit design is ETL and ETL, Canada, listed according to UL (Underwriters Laboratories) Standard 1995.

Navigator™ display module

When using the standard Navigator user interface, serviceability becomes even easier, including:

- local or remote alarm and alert monitoring
- self-diagnostic run testing to confirm control and component operation
- expedited troubleshooting and unit repair through self-diagnostic display of unit troubleshooting alert and alarm codes with expanded text descriptions to immediately identify reason for unit outage
- filter maintenance alarm
- monitoring of supply-air fan run time, permitting easy service schedule planning

Transducers

Serviceability is further facilitated with suction and discharge pressure transducers. These allow suction pressure and discharge pressure to be monitored remotely with alarm capability. These transducers also control condenser head pressure to maintain the minimum differential pressure required across the electronic expansion valve (EXV) for proper operation, reducing energy consumption.

Non-fused disconnect

A factory-installed non-fused disconnect (NFD) option is available to simplify unit installation and improve unit serviceability. The location of the NFD in the main control box simplifies field power supply routing into the unit. The NFD incorporates an access panel interlock feature, ensuring that all power to the unit is disconnected before a service person opens the control box.

Gas heat units (48N units)

The 48N units are gas heating units, using natural gas combustion, with up to 4 heat sizes available for every unit.

The unit heating systems employ multiple heat exchanger sections, with each section equipped with a 2-stage redundant gas valve and independent ignition control, with all sections operating in parallel.

Units with gas modulating heating are equipped with an additional modulating gas valve installed downstream of the 2-stage redundant gas valve.

Gas heat system

The induced draft fan system draws hot combustion gas through the heat exchanger tubes at the optimum rate for the most effective heat transfer and combustion process. The heat exchanger operates under a negative pressure, preventing flue gas leakage into the indoor supply air.

Flue outlet hoods with wind baffles are located on the side of the unit, to minimize the effects of wind on heating operations. Standard units use 2-stage control for unoccupied, morning warm-up, and occupied space heating. Modulating control option is available by specifying the modulating gas control option.

A single hinged panel gains access to the complete heat exchanger assembly and controls, for improved serviceability. A single point gas connection provides for easy installation.

Heat exchanger

The tubular steel heat exchanger design optimizes heat transfer for improved efficiency. The tubular design permits multiple passes across the supply air path. Each tube has an individual in-shot burner, ensuring uniform combustion in each tube of the heat exchangers.

Tubes are dimpled to create a turbulent gas flow to maximize heat efficiency and to ensure uniform surface temperatures for reduced corrosion effects, improved durability, and long-life service.

Heat exchanger material is aluminized steel or, optionally, stainless steel for improved corrosion resistance and reliability.

Integrated gas unit controller

The IGC (integrated gas unit controller) ignition and safety control system is used on each heat exchanger section. The IGC, unique to Carrier rooftop units, simplifies system evaluation and troubleshooting by providing system status and visual fault notification via an on-board LED (light-emitting diode).

Ignition is initiated by a direct spark ignition system; flame status is determined by flame rectification process.

Features/Benefits (cont)



Combustion fan operation is proven by a Hall Effect speed sensor circuit for units equipped with 2-stage or staged gas heat. For units equipped with modulating gas heat, combustion fan operation is proven with a pressure switch. Safeties include flame rollout and limit switch. Auto reset with manual lockout is also provided for repeated limit switch trips. The IGC also prevents short-cycling due to thermostat jiggle by ensuring a full minute heating cycle operation on each call for heat.

Optional modulating gas heat

The modulating gas heat option monitors unit supply-air temperature and controls the unit heat exchanger to provide first-stage demand heating control, with modulation to maintain user-configured heating supply air temperature set point. The option also provides full-fire demand heating on heating control command and tempering heat control, based on user-configured ventilation supply air temperature set point, to eliminate cold draft conditions with low

mixed-air temperatures. The modulating gas control option consists of a modulating controller capable of ensuring the proper fuel air mixture at operating firing rates, supply air temperature thermistors with duct-mounting base, a limit switch temperature thermistor, and stainless steel heat exchanger tubes.

Power Exhaust or Return Fan

- Building pressure control
- VFD controlled
- High-static fan option
- Airflow measurement options

Mixed Air and Final Filter Options

- Bag, cartridge, or pleated styles
- MERV 8 to 17

High-Efficiency Airfoil Supply Fan

- Premium-efficiency ODP or TEFC motor
- VFD control with soft start
- High-static fan option

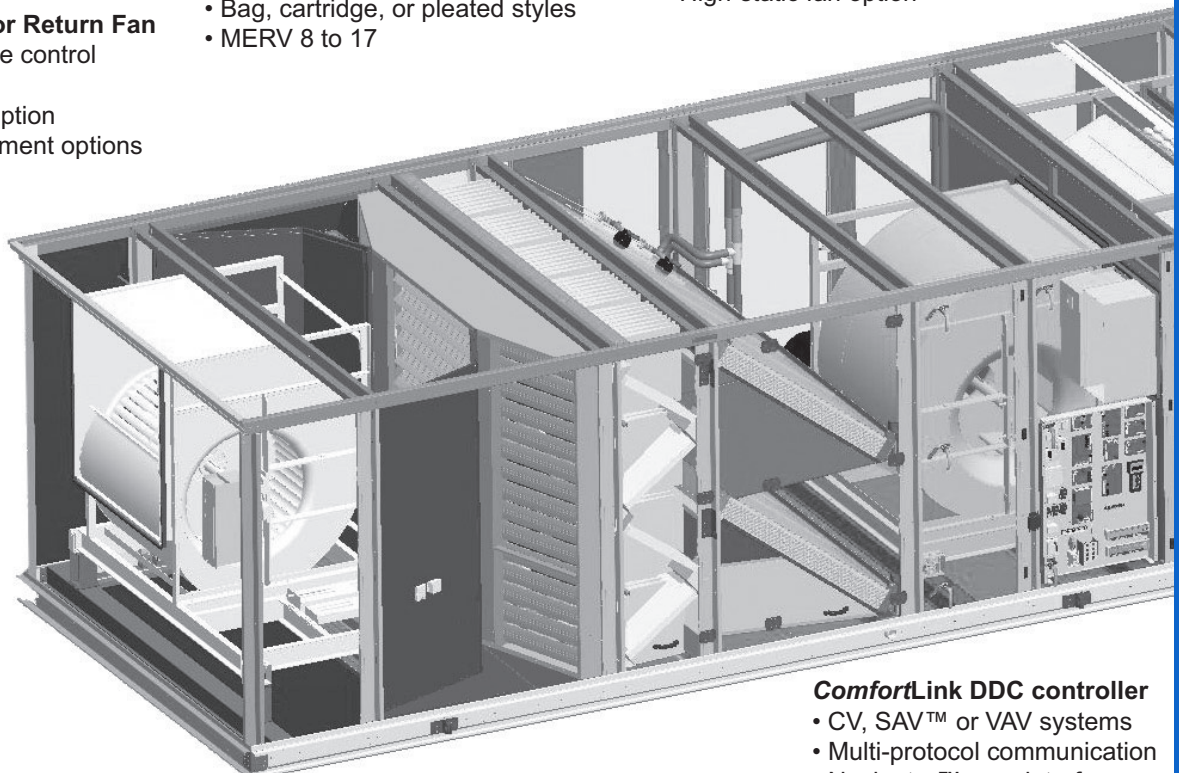

Cabinet Features

- Double wall foam panel design
- Pre-painted panels
- High strength steel roll formed base rails
- Hinged access panels, both sides
- Optional 4' and 8' blank sections
- Agion anti-microbial interior option

Ultra low leak economizer

- Blade and edge seals

ComfortLink DDC controller

- CV, SAV™ or VAV systems
- Multi-protocol communication
- Navigator™ user interface
- Prognostics and diagnostics

Evaporator section

- High-capacity evaporator option
- Electronic expansion valves
- Stainless steel double-sloped condensate pan
- Humidi-MiZer® dehumidification option

Electric heat units (50N units)

The 50N units may be equipped with factory-installed electric heat, with 3 heat sizes available for every unit. The heaters are resistance type, open wire nichrome elements, insulated with ceramic bushings, and include operating and safety controls. The standard heater control is a 2-stage type. An optional SCR control is available for applications requiring precise leaving air temperature control.

Optional SCR controlled electric heat

The SCR electric heat option monitors unit supply-air temperature and controls the electric heaters to provide first-stage demand heating control, with modulation to maintain user-configured heating supply air temperature set point. The option also provides full output demand heating on heating control command

and tempering heat control, based on user-configured ventilation supply air temperature set point, to eliminate cold draft conditions with low mixed-air temperatures. The SCR control option consists of an SCR controller capable of varying the heater output, supply air temperature thermistors with duct-mounting base, and required limit switch configurations.

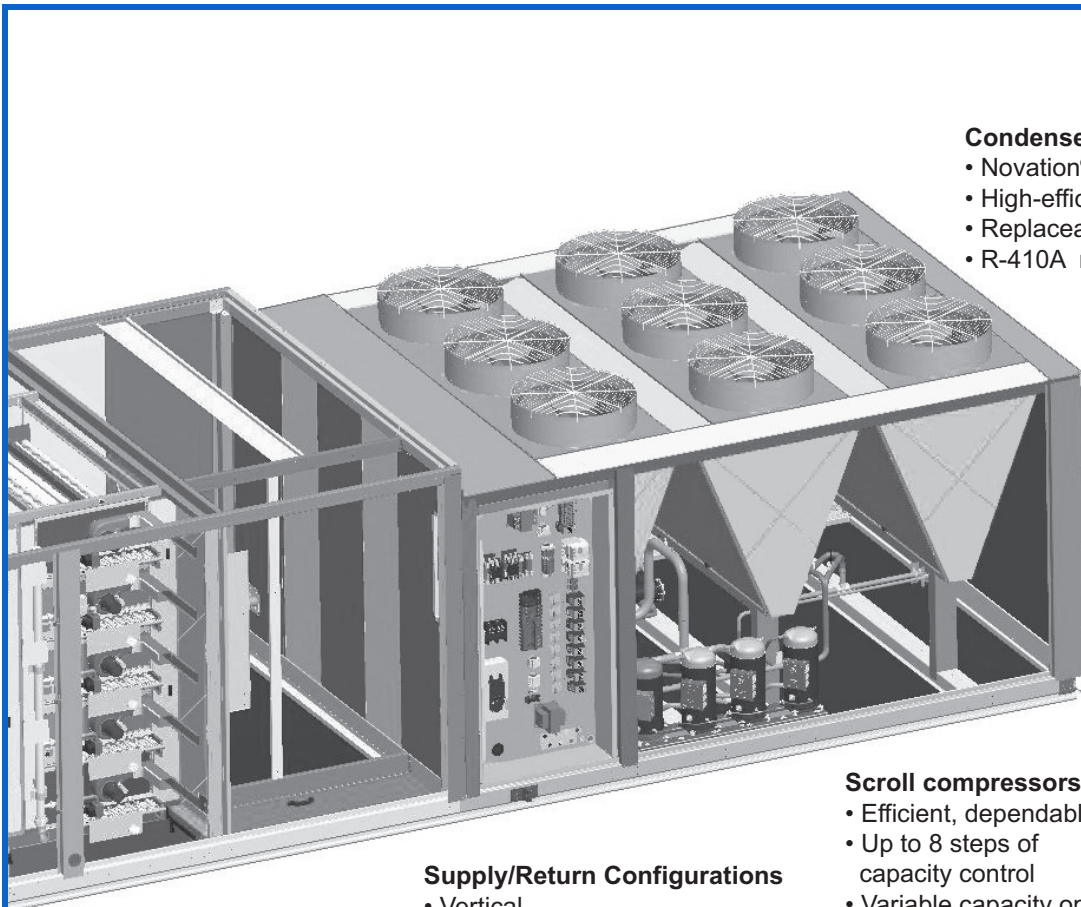

Condenser Section

- Novation® MCHX technology
- High-efficiency option
- Replaceable core filter drier option
- R-410A refrigerant

Scroll compressors

- Efficient, dependable
- Up to 8 steps of capacity control
- Variable capacity option

Supply/Return Configurations

- Vertical
- Horizontal
- Mixed

Heating Systems

- Gas, electric, or hydronic
- Staged or modulating control
- Induced-draft gas heat design

LEGEND

- CV** — Constant Volume
- MCHX** — Microchannel Heat Exchanger
- MERV** — Minimum Efficiency Reporting Value
- ODP** — Open Drip Proof
- SAV** — Staged Air Volume
- TEFC** — Totally Enclosed Fan Cooled
- VAV** — Variable Air Volume
- VFD** — Variable Frequency Drive

48N UNITS

48	N2	D	N	6	1	Option Code
48 – Cooling Unit with Gas Heat						<p>Factory Options See note below</p> <hr/> <p>Design Revision Level 1 – First Revision S – Special Order Unit</p> <hr/> <p>Voltage Options 1 – 575-3-60 6 – 460-3-60</p> <hr/> <p>Unit Size – Nominal Tons N – 75 P – 90 Q – 105 R – 120 S – 130 T – 150</p>
<p>Configuration N2 – Vertical Supply/Return, CV/SAV™ ComfortLink Controls N3 – Vertical Supply/Return, VAV ComfortLink Controls N4 – Horizontal Supply/Return, CV/SAV ComfortLink Controls N5 – Horizontal Supply/Return, VAV ComfortLink Controls N6 – Vertical Supply/Horizontal Return, CV/SAV ComfortLink Controls N7 – Vertical Supply/Horizontal Return, VAV ComfortLink Controls N8 – Horizontal Supply/Vertical Return, CV/SAV ComfortLink Controls N9 – Horizontal Supply/Vertical Return, VAV ComfortLink Controls</p> <hr/> <p>Heat and Chassis Options – – Low Gas Heat A – Medium Gas Heat B – High Gas Heat C – Low Gas Heat, Stainless Steel D – Medium Gas Heat, Stainless Steel E – High Gas Heat, Stainless Steel F – Low Gas Heat, Stainless Steel, Modulating G – Medium Gas Heat, Stainless Steel, Modulating H – High Gas Heat, Stainless Steel, Modulating J – Low Gas Heat, Humidi-MiZer® system K – Medium Gas Heat, Humidi-MiZer system L – High Gas Heat, Humidi-MiZer system M – Low Gas Heat, Stainless Steel, Humidi-MiZer system N – Medium Gas Heat, Stainless Steel, Humidi-MiZer system P – High Gas Heat, Stainless Steel, Humidi-MiZer system Q – Low Gas Heat, Stainless Steel, Modulating, Humidi-MiZer system R – Medium Gas Heat, Stainless Steel, Modulating, Humidi-MiZer system S – High Gas Heat, Stainless Steel, Modulating, Humidi-MiZer system T – Low Gas Heat, Extended Chassis V – Medium Gas Heat, Extended Chassis W – High Gas Heat, Extended Chassis X – Low Gas Heat, Stainless Steel, Extended Chassis Y – Medium Gas Heat, Stainless Steel, Extended Chassis Z – High Gas Heat, Stainless Steel, Extended Chassis 2 – Low Gas Heat, Stainless Steel, Modulating, Extended Chassis 3 – Medium Gas Heat, Stainless Steel, Modulating, Extended Chassis 4 – High Gas Heat, Stainless Steel, Modulating, Extended Chassis</p>						

Quality Assurance

ISO 9001: 2015-certified processes

LEGEND

CV — Constant Volume
SAV™ — Staged Air Volume
VAV — Variable Air Volume

NOTE: Because of the large number of options and the many resulting combinations, the Applied Rooftop Builder software must be used to generate the 10-digit option code for the unit model number. Refer to the software for the different choices for unit factory-installed options. Once all of the options have been selected, the software will generate the correct code. Unit options and accessories are listed in the Options and Accessories section.

Model number nomenclature (cont)



50N UNITS

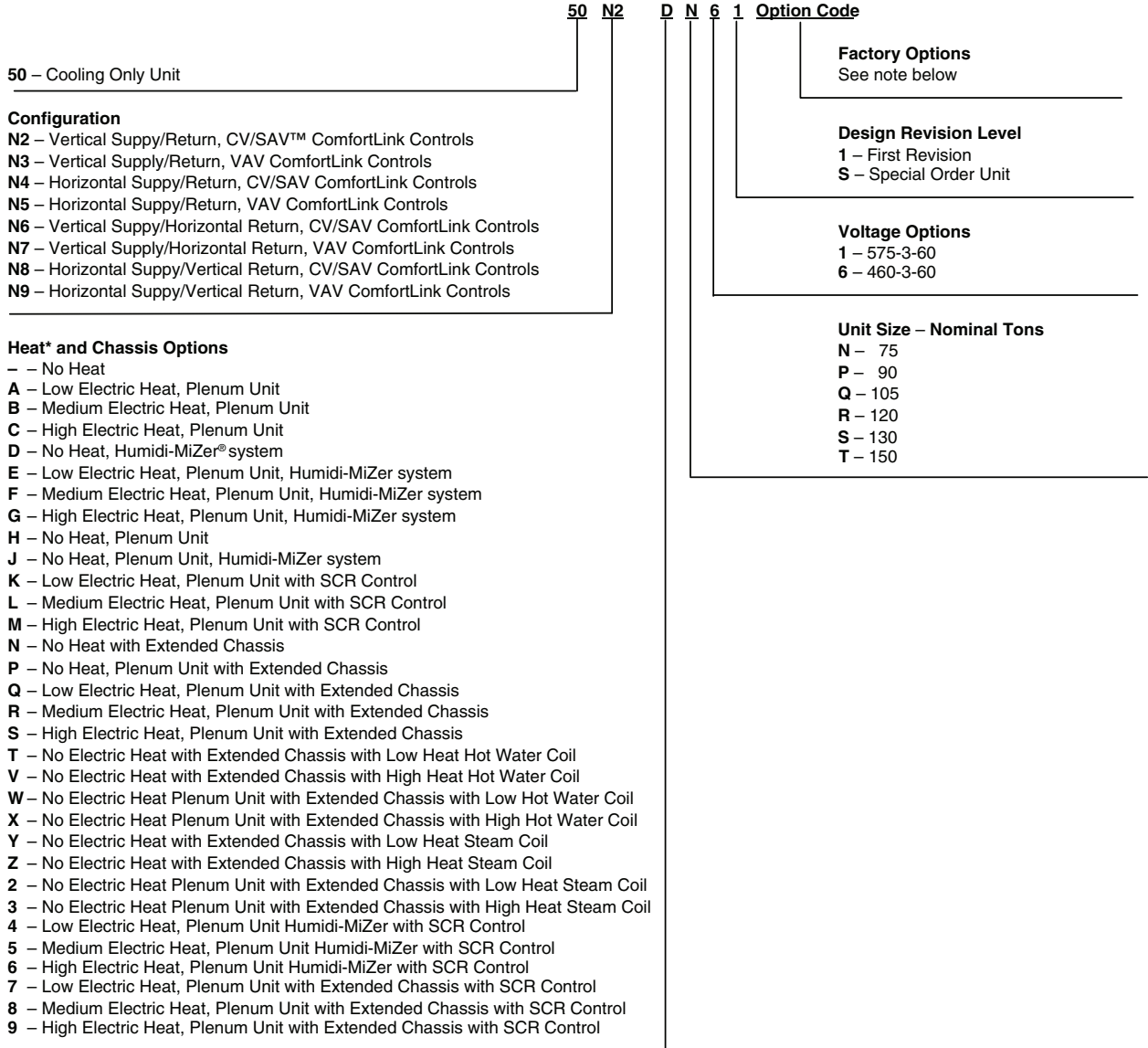

Quality Assurance

ISO 9001: 2015-certified processes

LEGEND

- CV** — Constant Volume
- SAV** — Staged Air Volume
- SCR** — Silicon-Controlled Rectifier
- VAV** — Variable Air Volume

*Electric heat available on 460 V only.

NOTE: Because of the large number of options and the many resulting combinations, the Applied Rooftop Builder software must be used to generate the 10-digit option code for the unit model number. Refer to the software for the different choices for unit factory-installed options. Once all of the options have been selected, the software will generate the correct code. Unit options and accessories are listed in the Options and Accessories section.

UNIT DESIGN AIRFLOW LIMITS

UNIT SIZE (NOMINAL CAPACITY, TONS)	UNIT TYPE	MINIMUM COOLING CFM	MAXIMUM COOLING CFM
N (75)	48N Low Heat	15,000	37,500
	48N High Heat	15,000	37,500
	50N Electric Heat	15,000	37,500
	50N No Heat	15,000	37,500
P (90)	48N Low Heat	18,000	45,000
	48N Medium Heat	18,000	45,000
	48N High Heat	18,000	45,000
	50N Electric Heat	18,000	45,000
	50N No Heat	18,000	45,000
Q (105)	48N Low Heat	21,000	47,000
	48N Medium Heat	21,000	47,000
	48N High Heat	21,000	47,000
	50N Electric Heat	21,000	47,000
	50N No Heat	21,000	47,000
R (120)	48N Low Heat	24,000	60,000
	48N Medium Heat	24,000	60,000
	48N High Heat	24,000	60,000
	50N Electric Heat	24,000	60,000
	50N No Heat	24,000	60,000
S (130)	48N Low Heat	26,000	60,000
	48N Medium Heat	26,000	60,000
	48N High Heat	26,000	60,000
	50N Electric Heat	26,000	60,000
	50N No Heat	26,000	60,000
T (150)	48N Low Heat	30,000	60,000
	48N Medium Heat	30,000	60,000
	48N High Heat	30,000	60,000
	50N Electric Heat	30,000	60,000
	50N No Heat	30,000	60,000

NOTE: Applies for standard filters only; additional filtration options may reduce maximum allowed airflow.

Ratings and capacities (cont)



TWO-STAGE GAS HEATING CAPACITIES - 48N UNITS (Natural Gas on All Units)

UNIT SIZE (NOMINAL CAPACITY, TONS)	NOMINAL CAPACITY IN TONS	GAS INPUT (1000 Btuh)		EFFICIENCY (%)	OUTPUT CAPACITY (1000 Btuh)		TEMP RISE (F)	AIRFLOW (Cfm)	
		Stage 1	Stage 2		Stage 1	Stage 2		Min	Max
N (75)	75 Low Heat	600	800	81	486	648	10-40	15,000	37,500
	75 High Heat	900	1200	81	729	972	20-50	15,000	37,500
P (90)	90 Low Heat	600	800	81	486	648	10-40	18,000	45,000
	90 Medium Heat	900	1200	81	729	972	20-50	18,000	45,000
	90 High Heat	1200	1600	81	972	1296	25-65	18,000	45,000
Q (105)	105 Low Heat	600	800	81	486	648	10-40	21,000	52,500
	105 Medium Heat	900	1200	81	729	972	20-50	21,000	52,500
	105 High Heat	1200	1600	81	972	1296	25-65	21,000	52,500
R (120)	120 Low Heat	900	1200	81	729	972	15-45	24,000	60,000
	120 Medium Heat	1200	1600	81	972	1296	20-50	24,000	60,000
	120 High Heat	1500	2000	81	1215	1620	25-55	24,000	60,000
S (130)	130 Low Heat	900	1200	81	729	972	15-45	26,000	60,000
	130 Medium Heat	1200	1600	81	972	1296	20-50	26,000	60,000
	130 High Heat	1500	2000	81	1215	1620	25-55	26,000	60,000
T (150)	150 Low Heat	900	1200	81	729	972	15-45	30,000	60,000
	150 Medium Heat	1200	1600	81	972	1296	20-50	30,000	60,000
	150 High Heat	1500	2000	81	1215	1620	25-55	30,000	60,000

NOTES:

- Ratings are approved for altitudes to 2000 ft. At altitudes over 2000 ft, ratings are 4% less for each 1000 ft above sea level.
- At altitudes up to 2000 ft, the following formula may be used to calculate air temperature rise:

$$\Delta t = \frac{\text{maximum output capacity}}{1.10 \times \text{air quantity}}$$

- At altitudes above 2000 ft, the following formula may be used:

$$\Delta t = \frac{\text{maximum output capacity}}{(.24 \times \text{specific weight of air} \times 60) (\text{air quantity})}$$

- Minimum allowable temperature of mixed air entering the heat exchanger during half-rate (first stage) operation is 35°F. There is no minimum mixture temperature limitation during full-rate operation.
- Temperature rise limits: see table.
- On VAV (variable air volume) applications set the zone terminals to provide minimum unit heating airflow as indicated in the table upon command from Heat Interlock Relay (HIR) function.

MODULATING GAS HEATING CAPACITIES — 48N UNITS (Natural Gas on All Units)

UNIT SIZE (NOMINAL CAPACITY, TONS)	NOMINAL CAPACITY IN TONS	GAS INPUT (1000 Btuh)		EFFICIENCY (%)	OUTPUT CAPACITY (1000 Btuh)		TEMP RISE (F)	AIRFLOW (Cfm)	
		Stage 1	Stage 2		Minimum	Maximum		Min	Max
N (75)	75 Low Heat	108	800	81	87.5	648	10-40	5,250	37,500
	75 High Heat	108	1200	81	87.5	972	20-50	5,250	37,500
P (90)	90 Low Heat	108	800	81	87.5	648	10-40	6,300	45,000
	90 Medium Heat	108	1200	81	87.5	972	20-50	6,300	45,000
	90 High Heat	108	1600	81	87.5	1296	25-65	6,300	45,000
Q (105)	105 Low Heat	108	800	81	87.5	648	10-40	7,350	52,500
	105 Medium Heat	108	1200	81	87.5	972	20-50	7,350	52,500
	105 High Heat	108	1600	81	87.5	1296	25-65	7,350	52,500
R (120)	120 Low Heat	108	1200	81	87.5	972	15-45	8,400	60,000
	120 Medium Heat	108	1600	81	87.5	1296	20-50	8,400	60,000
	120 High Heat	108	2000	81	87.5	1620	25-55	8,400	60,000
S (130)	130 Low Heat	108	1200	81	87.5	972	15-45	9,100	60,000
	130 Medium Heat	108	1600	81	87.5	1296	20-50	9,100	60,000
	130 High Heat	108	2000	81	87.5	1620	25-55	9,100	60,000
T (150)	150 Low Heat	108	1200	81	87.5	972	15-45	9,100	60,000
	150 Medium Heat	108	1600	81	87.5	1296	20-50	10,500	60,000
	150 High Heat	108	2000	81	87.5	1620	25-55	10,500	60,000

NOTES:

- Ratings are approved for altitudes to 2000 ft. At altitudes over 2000 ft, ratings are 4% less for each 1000 ft above sea level.
- At altitudes up to 2000 ft, the following formula may be used to calculate air temperature rise:

$$\Delta t = \frac{\text{maximum output capacity}}{1.10 \times \text{air quantity}}$$

- At altitudes above 2000 ft, the following formula may be used:

$$\Delta t = \frac{\text{maximum output capacity}}{(.24 \times \text{specific weight of air} \times 60) (\text{air quantity})}$$

- Minimum allowable temperature of mixed air entering the heat exchanger during half-rate (first stage) operation is 35°F. There is no minimum mixture temperature limitation during full-rate operation.
- Temperature rise limits: see table.
- On VAV (variable air volume) applications set the zone terminals to provide minimum unit heating airflow as indicated in the table upon command from Heat Interlock Relay (HIR) function.

ELECTRIC HEATER CAPACITIES (460 V ONLY)

UNIT SIZE (NOMINAL CAPACITY, TONS)	NO. STAGES	LOW (kW)	CAPACITY PER STAGE (%)	MED (kW)	CAPACITY PER STAGE (%)	HIGH (kW)	CAPACITY PER STAGE (%)	MIN CFM	MAX CFM
N (75)	2	108	50,100	144	50,100	190	50,100	15,000	37,500
P (90)	2	108	50,100	144	50,100	265	50,100	18,000	45,000
Q (105)	2	108	50,100	144	50,100	265	50,100	18,000	52,500
R (120)	2	144	50,100	265	50,100	300	50,100	24,000	60,000
S (130)	2	144	50,100	265	50,100	300	50,100	24,000	60,000
T (150)	2	144	50,100	265	50,100	300	50,100	24,000	60,000

NOTES:

- Minimum CFM is based on 200 per ton.
- Maximum CFM is based on of 500 per ton for small chassis and 400 per ton for large chassis.

STAGING SEQUENCES SIZE N STAGING SEQUENCE WITH MLV (75 TON NOMINAL CAPACITY)

STAGE	SEQUENCE						
	0	1*	1	2	3	4	5
COMP	Compressor Status						
A1	OFF	ON	ON	ON	ON	ON	ON
A2	OFF	OFF	OFF	OFF	ON	ON	ON
B1	OFF	OFF	OFF	ON	ON	ON	ON
B2	OFF	OFF	OFF	OFF	OFF	ON	ON
B3	OFF	OFF	OFF	OFF	OFF	OFF	ON
UNIT	Total Capacity						
075	0%	18%	23%	41%	65%	82%	100%

*Minimum load valve (MLV). MLV is enabled on Circuit A when decreasing from stage 1 to stage 0 to provide an increased stage of capacity.

SIZE N STAGING SEQUENCE WITH DIGITAL COMPRESSOR (75 TON NOMINAL CAPACITY)

STAGE	SEQUENCE					
	0	1	2	3	4	5
COMP	Compressor Status					
A1	OFF	ON	ON	ON	ON	ON
A2	OFF	OFF	OFF	ON	ON	ON
B1	OFF	OFF	ON	ON	ON	ON
B2	OFF	OFF	OFF	OFF	ON	ON
B3	OFF	OFF	OFF	OFF	OFF	ON
UNIT	Total Capacity					
075	0%	12% to 23%	29% to 41%	53% to 65%	71% to 82%	88% to 100%

SIZE N STAGING SEQUENCE WITHOUT MLV (75 TON NOMINAL CAPACITY)

STAGE	SEQUENCE						
	0	1	2	3	4	5	6
COMP	Compressor Status						
A1	OFF	OFF	ON	ON	ON	ON	ON
A2	OFF	OFF	OFF	OFF	ON	ON	ON
B1	OFF	ON	OFF	ON	ON	ON	ON
B2	OFF	OFF	OFF	OFF	OFF	ON	ON
B3	OFF	OFF	OFF	OFF	OFF	OFF	ON
UNIT	Total Capacity						
075	0%	18%	23%	41%	65%	82%	100%

SIZE P, Q STAGING SEQUENCE (90 AND 105 TON NOMINAL CAPACITY)

STAGE	SEQUENCE							
	0	1*	1	2	3	4	5	6
COMP	Compressor Status							
A1	OFF	ON	ON	ON	ON	ON	ON	ON
A2	OFF	OFF	OFF	OFF	ON	ON	ON	ON
A3	OFF	OFF	OFF	OFF	OFF	OFF	ON	ON
B1	OFF	OFF	OFF	ON	ON	ON	ON	ON
B2	OFF	OFF	OFF	OFF	OFF	ON	ON	ON
B3	OFF	OFF	OFF	OFF	OFF	OFF	OFF	ON
UNIT	Total Capacity							
090	0%	11%	15%	33%	49%	67%	82%	100%
105	0%	13%	17%	33%	50%	67%	83%	100%

*Minimum load valve (MLV). MLV is enabled on Circuit A when decreasing from stage 1 to stage 0 to provide an increased stage of capacity.

STAGING SEQUENCES (cont) SIZE P, Q STAGING SEQUENCE WITH DIGITAL COMPRESSOR (90 AND 105 TON NOMINAL CAPACITY)

STAGE	SEQUENCE						
	0	1	2	3	4	5	6
COMP	Compressor Status						
A1	OFF	ON	ON	ON	ON	ON	ON
A2	OFF	OFF	OFF	ON	ON	ON	ON
A3	OFF	OFF	OFF	OFF	OFF	ON	ON
B1	OFF	OFF	ON	ON	ON	ON	ON
B2	OFF	OFF	OFF	OFF	ON	ON	ON
B3	OFF	OFF	OFF	OFF	OFF	OFF	ON
UNIT	Total Capacity						
090	0%	8% to 15%	26% to 33%	41% to 49%	59% to 67%	74% to 82%	92% to 100%
105	0%	8% to 17%	25% to 33%	42% to 50%	58% to 67%	75% to 83%	92% to 100%

SIZE R, S, T STAGING SEQUENCE (120-150 TON NOMINAL CAPACITY)

STAGE	SEQUENCE									
	0	1*	1	2	3	4	5	6	7	8
COMP	Compressor Status									
A1	OFF	ON	ON	ON	ON	ON	ON	ON	ON	ON
A2	OFF	OFF	OFF	OFF	ON	ON	ON	ON	ON	ON
A3	OFF	OFF	OFF	OFF	OFF	OFF	ON	ON	ON	ON
A4	OFF	OFF	OFF	OFF	OFF	OFF	OFF	OFF	ON	ON
B1	OFF	OFF	OFF	ON	ON	ON	ON	ON	ON	ON
B2	OFF	OFF	OFF	OFF	OFF	ON	ON	ON	ON	ON
B3	OFF	OFF	OFF	OFF	OFF	OFF	OFF	ON	ON	ON
B4	OFF	OFF	OFF	OFF	OFF	OFF	OFF	OFF	OFF	ON
UNIT	Total Capacity									
120	0%	11%	14%	28%	40%	52%	64%	76%	88%	100%
130	0%	8%	11%	22%	35%	48%	61%	74%	87%	100%
150	0%	9%	13%	25%	38%	50%	63%	75%	88%	100%

*Minimum load valve (MLV). MLV is enabled on Circuit A when decreasing from stage 1 to stage 0 to provide an increased stage of capacity.

SIZE R, S, T STAGING SEQUENCE WITH DIGITAL COMPRESSOR (120-150 TON NOMINAL CAPACITY)

STAGE	SEQUENCE									
	0	1	2	3	4	5	6	7	8	
COMP	Compressor Status									
A1	OFF	ON	ON	ON	ON	ON	ON	ON	ON	ON
A2	OFF	OFF	OFF	ON	ON	ON	ON	ON	ON	ON
A3	OFF	OFF	OFF	OFF	OFF	ON	ON	ON	ON	ON
A4	OFF	OFF	OFF	OFF	OFF	OFF	OFF	ON	ON	ON
B1	OFF	OFF	ON	ON	ON	ON	ON	ON	ON	ON
B2	OFF	OFF	OFF	OFF	ON	ON	ON	ON	ON	ON
B3	OFF	OFF	OFF	OFF	OFF	OFF	ON	ON	ON	ON
B4	OFF	OFF	OFF	OFF	OFF	OFF	OFF	OFF	OFF	ON
UNIT	Total Capacity									
120	0%	7% to 14%	21% to 28%	33% to 40%	45% to 52%	57% to 64%	69% to 76%	81% to 88%	93% to 100%	
130	0%	6% to 11%	17% to 22%	30% to 35%	43% to 48%	56% to 61%	69% to 74%	82% to 87%	95% to 100%	
150	0%	6% to 13%	19% to 25%	31% to 38%	44% to 50%	56% to 63%	69% to 75%	81% to 88%	94% to 100%	

48/50N SIZES N-T (75-150 TONS NOMINAL CAPACITY)

BASE UNIT	N	P	Q	R	S	T
NOMINAL CAPACITY (tons)	75	90	105	120	130	150
WEIGHT (lb)						
Base Unit*	12,000	12,455	12,455	16,170	16,860	17,040
Split Unit - Main Section	9,110	9,565	9,565	12,880	13,570	13,750
Split Unit - Return Section	2,890	2,890	2,890	3,290	3,290	3,290
COMPRESSORS				Scroll		
Quantity	5	6	6	8	8	8
Oil Charge (oz) per Compressor	110	110	110	110	110	110
Compressor A1	ZP182	ZP154	ZP182	ZP182	ZP154	ZP182
Compressor A2	ZP182	ZP154	ZP182	ZP154	ZP182	ZP182
Compressor A3	—	ZP154	ZP182	ZP154	ZP182	ZP182
Compressor A4	—	—	—	ZP154	ZP182	ZP182
Compressor B1	ZP137	ZP182	ZP182	ZP182	ZP154	ZP182
Compressor B2	ZP137	ZP182	ZP182	ZP154	ZP182	ZP182
Compressor B3	ZP137	ZP182	ZP182	ZP154	ZP182	ZP182
Compressor B4	—	—	—	ZP154	ZP182	ZP182
Stages of Capacity, % Total Capacity	0,18,23,41,65,82,100	0,11,15,33,49,67,82,100	0,13,17,33,50,67,83,100	0,11,14,28,40,52,64,76,88,100	0,8,11,22,35,48,61,74,87,100	0,9,13,25,38,50,63,75,88,90
Number of Refrigerant Circuits	2	2	2	2	2	2
REFRIGERANT				R-410A		
Type				See Charge Table		
Charge Amount						
METERING DEVICE				Electronically controlled expansion devices... two (2) per circuit		
Type... Quantity per Circuit						
STANDARD EFFICIENCY UNIT CONDENSER				MCHX		
Material	Aluminum	Aluminum	Aluminum	Aluminum	Aluminum	Aluminum
Number of Total Coils	4	4	4	4	6	6
Total Face Area (sq ft)	138.7	173.3	173.3	173.3	173.3	260.0
HIGH EFFICIENCY UNIT CONDENSER				MCHX		
Material	Aluminum	Aluminum	Aluminum	Aluminum	Aluminum	NA
Number of Total Coils	4	6	6	6	6	
Total Face Area (sq ft)	138.7	173.3	260.0	260.0	260.0	
EVAP-STANDARD CAPACITY with STD EFFICIENCY				RTPF		
Material	CU-AL	CU-AL	CU-AL	CU-AL	CU-AL	CU-AL
Quantity	2	2	2	2	2	2
Tube Type	Cross Hatched	Cross Hatched	Cross Hatched	Cross Hatched	Cross Hatched	Cross Hatched
Rows (each)	4	4	6	4	6	6
FPI	16	16	16	16	16	16
Total Face Area (sq ft)	78.8	78.8	78.8	99.6	99.6	99.6
EVAP-STANDARD CAPACITY with HIGH EFFICIENCY				RTPF		
Material	CU-AL	CU-AL	CU-AL	CU-AL	CU-AL	NA
Quantity	2	2	2	2	2	
Tube Type	Cross Hatched	Cross Hatched	Cross Hatched	Cross Hatched	Cross Hatched	
Rows (each)	4	4	6	4	6	
FPI	16	16	16	16	16	
Total Face Area (sq ft)	78.8	78.8	78.8	99.6	99.6	
EVAP-HIGH CAPACITY with STD EFFICIENCY				RTPF		
Material	CU-AL	CU-AL	CU-AL	CU-AL	CU-AL	CU-AL
Quantity	2	2	2	2	2	2
Tube Type	Cross Hatched	Cross Hatched	Cross Hatched	Cross Hatched	Cross Hatched	Cross Hatched
Rows (each)	6	6	8	6	8	8
FPI	16	16	16	16	16	16
Total Face Area (sq ft)	78.8	78.8	78.8	99.6	99.6	99.6
EVAP-HIGH CAPACITY with HIGH EFFICIENCY				RTPF		
Material	CU-AL	CU-AL	CU-AL	CU-AL	CU-AL	NA
Quantity	2	2	2	2	2	
Tube Type	Cross Hatched	Cross Hatched	Cross Hatched	Cross Hatched	Cross Hatched	
Rows (each)	6	6	8	6	8	
FPI	16	16	16	16	16	
Total Face Area (sq ft)	78.8	78.8	78.8	99.6	99.6	
CONDENSER FAN, STANDARD EFFICIENCY						
Number of Fans	4	6	6	6	9	9
Type	Prop/Metal	Prop/Metal	Prop/Plastic	Prop/Plastic	Prop/Metal	Prop/Plastic
Diameter (in.)	30.5	30	30.5	30.5	30	30.5
Motor Hp	1	1	1	1	1	1
Nominal Cfm	41,000	81,000	81,000	81,000	93,000	122,400
Motor Rpm	1140	1140	1140	1140	1140	1140
CONDENSER FAN, HIGH EFFICIENCY						
Number of Fans	6	9	9	9	9	NA
Type	Prop/Metal	Prop/Plastic	Prop/Plastic	Prop/Plastic	Prop/Plastic	
Diameter (in.)	30.5	30.5	30.5	30.5	30.5	
Motor Hp	1	1	1	1	1	
Nominal Cfm	61,000	93,000	93,000	93,000	93,000	
Motor Rpm	1140	1140	1140	1140	1140	

LEGEND
CU-AL — Copper-to-Aluminum
DWDI — Double Width Double Inlet
FPI — Fins per Inch
MBtuh — Btuh in Thousands

MCHX — Microchannel Heat Exchanger
RTPF — Round Tube Plate Fin
SWSI — Single Width Single Inlet

* Base unit includes: economizer dampers and hoods, filter tracks less filters, evaporator coil mounting less the evaporator, extended plenum, and standard efficiency condenser. For 75-105 nominal ton units only, base unit weight also includes the short supply fan section. See pages 22 and 23 for option weights.

Physical data (cont)



48/50N SIZES N-T (75-150 TONS NOMINAL CAPACITY) (cont)

BASE UNIT	N	P	Q	R	S	T
NOMINAL CAPACITY (tons)	75	90	105	120	130	150
HUMIDIFIER® COIL	MCHX					
Type	Aluminum					
Material	1					
Quantity	E-Coated					
Surface						
Total Face Area (sq ft)	34.5	43	43	43	43	43
STANDARD AND HIGH CAPACITY HOT WATER COILS	RTPF					
Type	Aluminum Fin, Copper Tube					
Material	2					
Quantity	Smooth					
Tube Type	2					
Rows (each)	12					
FPI						
Total Face Area (sq ft)	22.4			26.4		
STANDARD AND HIGH CAPACITY STEAM COIL	RTPF					
Type	Aluminum Fin, Copper Tube, Steel Header, Sloped Casing					
Material	2					
Quantity	Smooth					
Tube Type	2.50, 3.00					
Connection Size, Length (in.)	40.1			49.0		
Total Face Area (sq ft)						
HEATING SECTION LOW (48N ONLY)						
Heating Section	2	2	2	3	3	3
Number of Heat Exchangers	18	18	18	27	27	27
Output (MBtuh)	648	648	648	972	972	972
Temperature Rise Range (F)	10-40	10-40	10-40	15-45	15-45	15-45
Efficiency (%)	81	81	81	81	81	81
Burner Orifice Quantity, Diameter (in.), Drill No.	18, 0.1285, 30	18, 0.1285, 30	18, 0.1285, 30	27, 0.1285, 30	27, 0.1285, 30	27, 0.1285, 30
Manifold Pressure (in. wg)	3.1	3.1	3.1	3.1	3.1	3.1
Line Pressure (in. wg) (min...max)	5.8-11	5.8-11	5.8-11	6.2-11	6.2-11	6.2-11
Firing Stages (Standard)	2	2	2	2	2	2
Firing Stages (Modulating)	14-100%	14-100%	14-100%	9-100%	9-100%	9-100%
Number of Gas Valves	2	2	2	3	3	3
HEATING SECTION MED (48N ONLY)						
Heating Section		3	3	4	4	4
Number of Heat Exchangers		27	27	36	36	36
Input/Output (MBtuh)		972	972	1296	1296	1296
Temperature Rise Range (F)		20-50	20-50	20-50	20-50	20-50
Efficiency (%)		81	81	81	81	81
Burner Orifice Quantity, Diameter (in.), Drill No.		27, 0.1285, 30	27, 0.1285, 30	36, 0.1285, 30	36, 0.1285, 30	36, 0.1285, 30
Manifold Pressure (in. wg)		3.1	3.1	3.1	3.1	3.1
Line Pressure (in. wg) (min...max)		6.3-11	6.3-11	6.2-11	6.2-11	6.2-11
Firing Stages (Standard)		2	2	2	2	2
Firing Stages (Modulating)		9-100%	9-100%	7-100%	7-100%	7-100%
Number of Gas Valves	NA	3	3	4	4	4
HEATING SECTION HIGH (48N ONLY)						
Heating Section	3	4	4	5	5	5
Number of Heat Exchangers	27	36	36	45	45	45
Input/Output (MBtuh)	972	1296	1296	1620	1620	1620
Temperature Rise Range (F)	20-50	25-65	25-65	25-55	25-55	25-55
Efficiency (%)	81	81	81	81	81	81
Burner Orifice Quantity, Diameter (in.), Drill No.	27, 0.1285, 30	36, 0.1285, 30	36, 0.1285, 30	45, 0.1285, 30	45, 0.1285, 30	45, 0.1285, 30
Manifold Pressure (in. wg)	3.1	3.1	3.1	3.1	3.1	3.1
Line Pressure (in. wg) (min...max)	6.3-11	6.3-11	6.3-11	6.2-11	6.2-11	6.2-11
Firing Stages (Standard)	2	2	2	2	2	2
Firing Stages (Modulating)	9-100%	7-100%	7-100%	5-100%	5-100%	5-100%
Number of Gas Valves	3	4	4	5	5	5
SUPPLY FAN						
Standard Supply Fan						
Diameter (in.)	28			32		
Wheel and Blade Type	DWDI Airfoil			DWDI Airfoil		
Maximum Allowable Cf _m	42,000			60,000		
Maximum Allowable Speed (rpm)	1,800			1,550		
Shaft Diameter at Pulley (in.)	2.25			2.5		
High Static Supply Fan						
Diameter (in.)	40			40		
Wheel and Blade Type	DWDI Airfoil			DWDI Airfoil		
Maximum Allowable Cf _m	52,500			60,000		
Maximum Allowable Speed (rpm)	1,250			1,250		
Shaft Diameter at Pulley (in.)	3			3		

Physical data (cont)



48/50N SIZES N-T (75-150 TONS NOMINAL CAPACITY) (cont)

BASE UNIT	N	P	Q	R	S	T
NOMINAL CAPACITY (tons)	75	90	105	120	130	150
OPTIONAL POWER EXHAUST						
Power Exhaust						
Diameter (in.)	20				23	
Wheel and Blade Type				DWDI Forward Curve		
Maximum Allowable Cfm	42,000				60,000	
Maximum Allowable Speed (rpm)	1,200				1,200	
Shaft Diameter at Pulley (in.)	1.75				1.75	
High Static Power Exhaust						
Diameter (in.)		36				40
Wheel and Blade Type		DWDI Forward Curve				DWDI Forward Curve
Maximum Allowable Cfm		42,000				60,000
Maximum Allowable Speed (rpm)		650				600
Shaft Diameter at Pulley (in.)		2.5				3
OPTIONAL RETURN FAN						
Return Fan						
Diameter (in.)		40				40
Wheel and Blade Type		SWSI Plenum Airfoil				SWSI Plenum Airfoil
Maximum Allowable Cfm		52,500				60,000
Maximum Allowable Speed (rpm)		1236				1236
Shaft Diameter at Pulley (in.)		2.5				2.5
High Static Return Fan						
Diameter (in.)	45	50				56
Wheel and Blade Type				SWSI Plenum Airfoil		
Maximum Allowable Cfm	60,000	60,000				60,000
Maximum Allowable Speed (rpm)	850	780				720
Shaft Diameter at Pulley (in.)				3		
MIXED AIR FILTERS						
MERV 7 Pleated Filters	2 inch, MERV 7			2 inch, MERV 7		
Quantity	28			28		
Size (in.)	20x24x2			20x25x2		
MERV 8 Pleated Filters	4 inch, MERV 8			4 inch, MERV 8		
Quantity	28			28		
Size (in.)	20x24x4			20x25x4		
MERV 14 Pleated Filters	4 inch, MERV 14			4 inch, MERV 14		
Quantity	28			28		
Size (in.)	20x24x4			20x25x4		
MERV 14 Cartridge Filters, 2 or 4-in. in Pre-Filters	12 inch, MERV 14 Cartridge Filters			12 inch, MERV 14 Cartridge Filters		
Quantity	20			20		
Size (in.)	(15) 20x24x12, (5) 24x24x12			(15) 20x24x12, (5) 24x24x12		
MERV 14 Bag, 2 or 4-in. in Pre-Filters	12 inch, MERV 14 Bag Filters			12 inch, MERV 14 Bag Filters		
Quantity	20			20		
Size (in.)	(15) 20x24x12, (5) 24x24x12			(15) 20x24x12, (5) 24x24x12		
MERV 15 Bag, 2 or 4-in. in Pre-Filters	19 inch, MERV 15 Bag Filters			19 inch, MERV 15 Bag Filters		
Quantity	20			20		
Size (in.)	(15) 20x24x19, (5) 24x24x19			(15) 20x24x12, (5) 24x24x12		
FINAL FILTERS						
MERV 14 Cartridge Filters, 2 or 4-in. in Pre-Filters	12 inch, MERV 14 Cartridge Filters			12 inch, MERV 14 Cartridge Filters		
Quantity	19			19		
Size (in.)	(14) 20x24x12, (5) 24x24x12			24x24x12		
MERV 15 Bag, 2 or 4-in. in Pre-Filters	19 inch, MERV 15 Bag Filters			19 inch, MERV 15 Bag Filters		
Quantity	19			19		
Size (in.)	(14) 20x24x19, (5) 24x24x19			24x24x19		
MERV 17 HEPA, 2 or 4-in. in Pre-Filters	12 inch, MERV 17 HEPA Filters, 99.99%			12 inch, MERV 17 HEPA Filters, 99.99%		
Quantity	19			19		
Size (in.)	(14) 24x12x12, (5) 24x24x12			24x24x12		
OUTSIDE AIR SCREENS						
Standard Hood (Motorized OA and Economizer Options)	Aluminum Frame, Permanent					
Quantity	12 Screens			16 Screens		
Size (in.)	16 7/8 x 31			16 7/8 x 31		

LEGEND

Cu-Al	—	Copper-to-Aluminum
DWDI	—	Double Width Double Inlet
FPI	—	Fins per Inch
MBtuh	—	Btuh in Thousands
MCHX	—	Microchannel Heat Exchanger
RTPF	—	Round Tube Plate Fin
SWSI	—	Single Width Single Inlet

REFRIGERANT CHARGE (lb)

UNIT SIZE (NOMINAL CAPACITY, TONS)	UNIT CONFIGURATION	UNITS WITHOUT HUMIDI-MIZER® SYSTEM		UNITS WITH HUMIDI-MIZER® SYSTEM	
		Circuit A	Circuit B	Circuit A	Circuit B
N (75)	Standard Capacity Standard Efficiency	46.5	52.6	46.5	69.6
	High Capacity Standard Efficiency	62.9	69.0	62.9	86.0
	Standard Capacity High Efficiency	50.2	56.5	50.2	73.5
	High Capacity High Efficiency	67.0	73.5	67.0	90.5
P (90)	Standard Capacity Standard Efficiency	55.4	52.0	55.4	71.5
	High Capacity Standard Efficiency	67.8	68.5	67.8	88.3
	Standard Capacity High Efficiency	59.0	57.2	59.0	76.7
	High Capacity High Efficiency	73.8	73.8	73.8	94.0
Q (105)	Standard Capacity Standard Efficiency	71.5	67.9	71.5	87.4
	High Capacity Standard Efficiency	89.5	81.9	89.5	101.4
	Standard Capacity High Efficiency	77.5	72.9	77.5	92.4
	High Capacity High Efficiency	91.6	88.2	91.6	107.7
R (120)	Standard Capacity Standard Efficiency	59.9	57.1	59.9	76.6
	High Capacity Standard Efficiency	80.3	77.1	80.3	96.6
	Standard Capacity High Efficiency	66.5	63.3	66.5	82.8
	High Capacity High Efficiency	87.1	83.3	87.1	102.8
S (130)	Standard Capacity Standard Efficiency	84.9	81.2	84.9	100.7
	High Capacity Standard Efficiency	106.0	99.5	106.0	119.0
	Standard Capacity High Efficiency	84.5	80.7	84.5	100.2
	High Capacity High Efficiency	105.5	99.0	105.5	118.5
T (150)	Standard Capacity Standard Efficiency	82.5	82.0	82.5	101.5
	High Capacity Standard Efficiency	103.5	101.2	103.5	121.7

SUPPLY FAN AND DRIVE INFORMATION

FAN	MOTOR HP	MOTOR RPM	MOTOR SHAFT SIZE (in.)	FAN RPM	FAN SHAFT SIZE (in.)	DRIVE SHEAVE BROWNING	BUSHING TYPE	DRIVEN SHEAVE BROWNING	BUSHING TYPE	BELTS	QTY OF BELTS	FAN SPEED (rpm)
Standard Fan 75-105 Tons Nominal Capacity	50	1770	2.125	1800	2.25	4B5V70	B 2 1/8	4B5V68	B 2 1/4	5VX530	4	1821/1821
	40	1770	2.125	1600		3B5V68	B 2 1/8	3B5V74	B 2 1/4	5VX540	3	1628/1628
	30	1765	1.875	1450		3B5V70	B 1 7/8	3B5V86	B 2 1/4	BX55	3	1448/1448
	25	1765	1.875	1400		3B5V64	B 1 7/8	3B5V80	B 2 1/4	BX53	3	1425/1425
	20	1765	1.625	1250		3B5V56	B 1 5/8	3B5V80	B 2 1/4	BX53	3	1255/1255
	15	1770	1.625	1100		2B5V64	B 1 5/8	2Q5V103	Q1 2 1/4	5VX600	2	1128/1128
Standard Fan 120-150 Tons Nominal Capacity	60	1775	2.375	1550	2.5	4B5V70	B 2 3/8	4R5V80	R1 2 1/2	5VX600	4	1595/1595
	50	1770	2.125	1400		4B5V70	B 2 1/8	4R5V90	R1 2 1/2	5VX630	4	1412/1412
	40	1770	2.125	1300		3B5V68	B 2 1/8	3R5V92	R1 2 1/2	5VX630	3	1328/1328
	30	1765	1.875	1200		3B5V70	B 1 7/8	3R5V103	R1 2 1/2	5VX670	3	1229/1229
	25	1765	1.875	1100		3B5V64	B 1 7/8	3R5V103	R1 2 1/2	5VX660	3	1125/1125
	20	1765	1.625	1000		3B5V56	B 1 5/8	3R5V103	R1 2 1/2	5VX660	3	986/986
High Static 75-150 Tons Nominal Capacity	100	1775	2.875	1250	3	5R5V90	R1 2 7/8	5B5V124	R1 3	5VX830	5	1264/1264
	75	1775	2.375	1100		4B5V80	B 2 3/8	4R5V132	R1 3	5VX840	4	1098/1098
	60	1775	2.375	1050		4B5V70	B 2 3/8	4R5V118	R1 3	5VX800	4	1077/1077
	50	1770	2.125	1000		4B5V70	B 2 1/8	4R5V125	R1 3	5VX830	4	1013/1013
	40	1770	2.125	900		3B5V68	B 2 1/8	3R5V140	R1 3	5VX850	3	918/918
	30	1765	1.875	800		3B5V70	B 1 7/8	3B154R	R1 3	BX88	3	821/821
	25	1765	1.875	750		3B5V64	B 1 7/8	3B154R	R1 3	BX87	3	753/753
	20	1765	1.625	700		3B5V56	B 1 5/8	3R5V140	R1 3	5VX860	3	724/724

POWER EXHAUST FAN AND DRIVE INFORMATION

FAN	MOTOR HP	MOTOR RPM	MOTOR SHAFT SIZE (in.)	FAN RPM	FAN SHAFT SIZE (in.)	DRIVE SHEAVE BROWNING	BUSHING TYPE	DRIVEN SHEAVE BROWNING	BUSHING TYPE	BELTS	QTY OF BELTS	FAN SPEED (rpm)
Standard Fan 75 Tons Nominal Capacity	30	1765	1.875	1200	1.75	3B5V70	B 1 7/8	3R5V103	R1 1 3/4	5VX570	3	1229/1229
	25	1765	1.875	1150		3B5V64	B 1 7/8	3R5V103	R1 1 3/4	5VX560	3	1125/1125
	20	1765	1.625	1125		3B5V56	B 1 5/8	3B5V90	B 1 3/4	BX52	3	1120/1120
	15	1770	1.625	1100		2B5V64	B 1 5/8	2Q5V103	Q1 1 3/4	5VX580	2	1128/1128
	10	1755	1.375	1100		2BK52H	H 1 3/8	2B5V74	B 1 3/4	BX51	2	1117/1117
	7.5	1760	1.375	1100		2BK52H	H 1 3/8	2B5V74	B 1 3/4	BX51	2	1120/1120
Standard Fan 90-150 Tons Nominal Capacity	50	1770	2.125	1200	1.75	4B5V70	B 2 1/8	4R5V103	R1 1 3/4	5VX540	4	1225/1225
	40	1770	2.125	1175		3B5V68	B 2 1/8	3R5V103	R1 1 3/4	5VX540	3	1197/1197
	30	1765	1.875	1150		3B5V70	B 1 7/8	3B5V110	B 1 3/4	5VX580	3	1129/1129
	25	1765	1.875	1125		3B5V64	B 1 7/8	3R5V103	R1 1 3/4	5VX550	3	1125/1125
	20	1765	1.625	1100		3B5V56	B 1 5/8	3B5V90	B 1 3/4	BX52	3	1120/1120
	15	1770	1.625	1050		2B5V64	B 1 5/8	2B5V110	B 1 3/4	5VX590	2	1036/1036
	10	1755	1.375	1000		2BK52H	H 1 3/8	2B5V80	B 1 3/4	BX51	2	1036/1036
	7.5	1760	1.375	950		2BK52H	H 1 3/8	2B5V90	B 1 3/4	BX53	2	927/927
High Static 75-90 Tons Nominal Capacity	40	1770	2.125	650	2.5	3B5V68	B 2 1/8	35V1870E	E 2 1/2	5VX830	3	657/657
	30	1765	1.875	625		3B5V70	B 1 7/8	3TB200	Q1 2 1/2	BX86	3	635/635
	25	1765	1.875	600		3B5V64	B 1 7/8	3TB200	Q1 2 1/2	BX85	3	583/583
	20	1765	1.625	550		3B5V56	B 1 5/8	3TB184	Q1 2 1/2	BX82	3	557/557
	15	1770	1.625	500		2B5V64	B 1 5/8	25V2360E	E 2 1/2	5VX950	2	490/490
	10	1755	1.375	450		2BK52H	H 1 3/8	2TB184	Q1 2 1/2	BX82	2	460/460
	7.5	1760	1.375	425		2BK52H	H 1 3/8	2TB184	Q1 2 1/2	AX81	2	425/425
High Static 105-150 Tons Nominal Capacity	60	1775	2.375	600	3	4B5V70	B 2 3/8	4R5V212	R1 3	5VX930	4	597/597
	50	1770	2.125	575		4B5V70	B 2 1/8	4R5V212	R1 3	5VX950	4	596/596
	40	1770	2.125	550		3B5V68	B 2 1/8	3R5V212	R1 3	5VX930	3	579/579
	30	1765	1.875	525		3B5V70	B 1 7/8	3B250R	R1 3	BX103	3	509/509
	25	1765	1.875	500		3B5V64	B 1 7/8	35V2360E	E 3	5VX1000	3	488/488
	20	1765	1.625	450		3B5V56	B 1 5/8	35V2360E	E 3	5VX1000	3	428/428
	15	1770	1.625	400		2B5V64	B 1 5/8	2B300R	R1 3	BX112	2	391/391

RETURN FAN AND DRIVE INFORMATION

FAN	MOTOR HP	MOTOR RPM	MOTOR SHAFT SIZE (in.)	FAN RPM	FAN SHAFT SIZE (in.)	DRIVE SHEAVE BROWNING	BUSHING TYPE	DRIVEN SHEAVE BROWNING	BUSHING TYPE	BELTS	QTY OF BELTS	FAN SPEED (rpm)
RETURN FAN												
Standard Return Fan All Sizes	50	1770	2.125	1236	2.5	4B5V70	B 2 1/8	4R5V103	R1 2 1/2	5VX1000	4	1232/1232
	40	1770	2.125	1149		3B5V68	B 2 1/8	3R5V109	R1 2 1/2	5VX1000	3	1131/1131
	30	1765	1.875	1025		3B5V70	B 1 7/8	3TB124	Q1 2 1/2	BX98	3	1015/1015
	25	1765	1.875	940		3B5V64	B 1 7/8	3TB124	Q1 2 1/2	BX98	3	931/931
	20	1765	1.625	930		3B5V56	B 1 5/8	3TB110	Q1 2 1/2	BX93	3	922/922
	15	1770	1.625	890		2B5V64	B 1 5/8	2Q5V132	Q1 2 1/2	5VX1000	2	878/878
	10	1755	1.375	770		2BK52H	H 1 3/8	2TB110	Q1 2 1/2	BX90	2	761/761
	7.5	1760	1.375	720		2BK52H	H 1 3/8	2TB110	Q1 2 1/2	AX89	2	717/717
High Static Return Fan 75 Tons Nominal Capacity	30	1765	1.875	850	3	3B5V70	B 1 7/8	3R5V150	R1 3	5VX1120	3	841/841
	25	1765	1.875	825		3B5V64	B 1 7/8	3R5V140	R1 3	5VX1120	3	825/825
	15	1770	1.625	680		2B5V64	B 1 5/8	2B160R	R1 3	BX112	2	728/728
	10	1755	1.375	600		2BK52H	H 1 3/8	2B154R	R1 3	BX105	2	548/548
	7.5	1760	1.375	550		2BK52H	H 1 3/8	2B154R	R1 3	BX105	2	549/549
High Static Return Fan 90 Tons Nominal Capacity	40	1770	2.125	780	3	3B5V68	B 2 1/8	3R5V160	R1 3	5VX1230	3	768/768
	30	1765	1.875	750		3B5V70	B 1 7/8	3B160R	R1 3	BX120	3	790/790
	25	1765	1.875	720		3B5V64	B 1 7/8	3B160R	R1 3	BX120	3	725/725
	20	1765	1.625	650		3B5V56	B 1 5/8	3B154R	R1 3	BX113	3	663/663
	15	1770	1.625	600		2B5V64	B 1 5/8	2B200R	R1 3	BX123	2	584/584
	10	1755	1.375	520		2BK52H	H 1 3/8	2B160R	R1 3	BX112	2	528/528
	7.5	1760	1.375	480		2BK52H	H 1 3/8	2B184R	R1 3	BX116	2	461/461
	High Static Return Fan 105-150 Tons Nominal Capacity	60	1775	2.375		720	3	4B5V70	B 2 3/8	4B174R	R1 3	BX133
50		1770	2.125	680	4B5V70	B 2 1/8		45V1870E	E 3	5VX1320	4	676/676
40		1770	2.125	650	3B5V68	B 2 1/8		35V1870E	E 3	5VX1320	3	657/657
30		1765	1.875	580	3B5V70	B 1 7/8		3R5V212	R1 3	5VX1400	3	594/594
25		1765	1.875	550	3B5V64	B 1 7/8		3B200R	R1 3	AX128	3	555/555
20		1765	1.625	500	3B5V56	B 1 5/8		3B200R	R1 3	BX128	3	513/513
15		1770	1.625	450	2B5V64	B 1 5/8		2B250R	R1 3	AX136	2	444/444
10		1755	1.375	400	2BK52H	H 1 3/8		2B200R	R1 3	AX128	2	392/392

MOTORS

HP	VOLTAGE	CARRIER PART NO.	NEMA	RPM	EFFICIENCY
7.5	575	HD62FK576	213T	1750	91.0%
	460	HD62FK653	213T	1760	91.7%
10	575	HD64FK575	215T	1755	91.7%
	460	HD64FK652	215T	1755	91.7%
15	575	HD66FK575	254T	1770	93.0%
	460	HD66FK652	254T	1770	93.0%
20	575	HD68FK575	256T	1765	93.0%
	460	HD68FK652	256T	1765	93.6%
25	575	HD70FK576	284T	1765	93.6%
	460	HD70FK652	284T	1765	93.6%
30	575	HD72FK576	286T	1770	94.1%
	460	HD72FK653	286T	1760	92.4%
40	575	HD74FK575	324T	1770	93.6%
	460	HD74FE654	324T	1780	94.1%
50	575	HD75FL575	326T	1770	94.5%
	460	HD76AE654	326T	1780	94.5%
60	575	HD76FL575	364T	1775	95.0%
	460	HD78AE656	364T	1785	95.0%
75	575	HD79FL575	365T	1775	95.0%
	460	HD80FE656	365T	1785	95.0%
100	575	HD82FR575	404T	1775	95.4%
	460	HD82FR651	404T	1775	95.4%

WEIGHT DISTRIBUTION AND CENTER OF GRAVITY

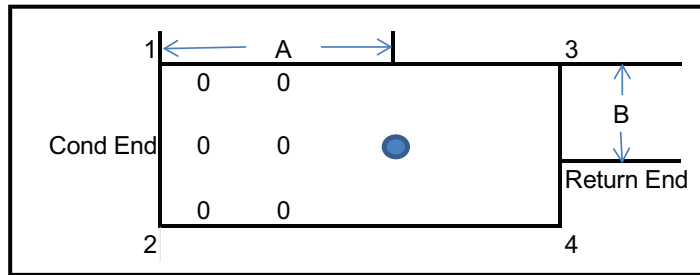

UNITS	SIZE	CORNER WEIGHTS (lb)				TOTAL (lb)	A	B
		1	2	3	4		in.	in.
50 Series Non-Split Typical Featured Unit: <ul style="list-style-type: none"> Economizer Barometric Relief Standard Filters High Capacity Evaporator High Efficiency High Supply Fan with Largest Motor High Power Exhaust with Largest Motor No Heat No Post Section No Humid-MiZer System No Extended Chassis No Field Filter Section 	75	3958	3880	4590	4500	16,927	238.3	67.2
	90	4238	4154	5044	4945	18,382	269.4	67.2
	105	4330	4245	5200	5098	18,873	270.5	67.2
	120	5257	5153	6117	5996	22,523	271.9	67.2
	130	5201	5099	6348	6223	22,871	277.9	67.2
	150	5253	5149	6445	6318	23,164	278.6	67.2
48 Series Non-Split Typical Featured Unit: <ul style="list-style-type: none"> Economizer Barometric Relief Standard filters High Capacity Evaporator High Efficiency High Supply Fan with Largest Motor High Power Exhaust with Largest Motor Low Gas Heat No Post Section No Extended Chassis No Humid-MiZer System No Field Filter Section 	75	4129	4047	4892	4796	17,864	275.9	67.2
	90	4396	4310	5359	5254	19,319	308.1	67.2
	105	4478	4390	5526	5417	19,810	309.8	67.2
	120	5455	5347	6474	6346	23,622	309.7	67.2
	130	5385	5279	6719	6587	23,970	316.7	67.2
	150	5436	5329	6816	6682	24,263	317.5	67.2
50 Series Split Complete Unit Typical Featured Unit: <ul style="list-style-type: none"> Economizer Barometric Relief Cartridge Filters High Capacity Evaporator High Efficiency High Supply Fan with Largest Motor High Return Fan with Largest Motor High Electric Heat 8' Blank Section with Post Filters Extended Chassis with Humid-MiZer System No Field Filter Section 	75	4453	4365	5458	5351	19,627	352.1	67.2
	90	4726	4633	5994	5876	21,229	386.5	67.2
	105	4811	4716	6264	6141	21,932	391.0	67.2
	120	5777	5663	7211	7069	25,719	389.3	67.2
	130	5693	5580	7471	7323	26,067	397.9	67.2
	150	5742	5629	7569	7420	26,360	398.7	67.2
48 Series Split Complete Unit Typical Featured Unit: <ul style="list-style-type: none"> Economizer Barometric Relief Cartridge Filters High Capacity Evaporator High Efficiency High Supply Fan with Largest Motor High Return Fan with Largest Motor High Gas Heat 8' Blank Section with Post Filters Extended Chassis with Humid-MiZer System No Field Filter Section 	75	4684	4592	5690	5578	20,544	355.1	67.2
	90	4969	4871	6273	6149	22,261	390.3	67.2
	105	5052	4952	6544	6415	22,964	394.8	67.2
	120	6058	5939	7583	7433	27,013	401.0	67.2
	130	5972	5854	7845	7691	27,361	409.6	67.2
	150	6021	5903	7944	7787	27,654	410.3	67.2

NOTE: The weight distribution and center of gravity information include the impact of an economizer, the largest indoor fan motor, and a VFD (variable frequency drive). On units with a return fan or high-capacity power exhaust, the largest motors and VFD are also included. These weights do not include the impact of other factory-installed options such as barometric relief, power exhaust, high-capacity indoor coil, hot water coil, or indoor fan.

OPERATING WEIGHTS OF OPTIONS AND ACCESSORIES (lb)

OPTION OR ACCESSORY	48/50N UNIT SIZE (TON NOMINAL CAPACITY)					
	N (75)	P (90)	Q (105)	R (120)	S (130)	T (150)
Economizer	140	140	140	140	140	140
Filters						
2 in. MERV 7	90	90	90	100	100	100
4 in. MERV 8	150	150	150	175	175	175
4 in. MERV 14	175	175	175	210	210	210
12 in. MERV 14 Bag with 2 in. Pre-Filter	200	200	200	225	225	225
12 in. MERV 14 Bag with 4 in. Pre-Filter	260	260	260	300	300	300
19 in. MERV 15 Bag with 2 in. Pre-Filter	300	300	300	335	335	335
19 in. MERV 15 Bag with 4 in. Pre-Filter	320	320	320	350	350	350
12 in. MERV 14 Cartridge with 2 in. Pre-Filter	350	350	350	375	375	375
12 in. MERV 14 Cartridge with 4 in. Pre-Filter	370	370	370	400	400	400
Field Use Filter Section	635	635	635	665	665	665
Evaporator						
Standard Capacity	625	625	832	795	1053	1053
High Capacity	832	832	1110	1053	1402	1402
High-Efficiency Condenser	310	691	691	691	None	NA
Extended Chassis	320	320	320	335	335	335
Humidi-MiZer® Dehumidification System	475	495	495	510	510	510
Hot Water Coil						
Low Capacity	671	671	671	759	759	759
High Capacity	693	693	693	783	783	783
Steam Coil						
Low Capacity	837	940	940	1063	1063	1063
High Capacity	940	1043	1043	1187	1187	1187
Electric Heat						
Low	175	175	175	185	185	185
Medium	185	185	185	215	215	215
High	200	215	215	225	225	225
Gas Heat						
Low	937	937	937	1099	1099	1099
Medium	NA	1067	1067	1229	1229	1229
High	1067	1197	1197	1469	1469	1469
Modulating	50	50	50	50	50	50
Blank Section						
4 ft	530	530	530	555	555	555
8 ft	1060	1060	1060	1110	1110	1110
Post Filters						
19 in. MERV 15 Bag with 2 in. Pre-Filter	830	830	830	890	890	890
19 in. MERV 15 Bag with 4 in. Pre-Filter	850	850	850	905	905	905
12 in. MERV 14 Cart with 2 in. Pre-Filter	880	880	880	930	930	930
12 in. MERV 14 Cart with 4 in. Pre-Filter	900	900	900	955	955	955
12 in. MERV 17 HEPA with 2 in. Pre-Filter	905	905	905	965	965	965
12 in. MERV 17 HEPA with 4 in. Pre-Filter	930	930	930	980	980	980
Supply Fan						
High-Static Supply Fan	1274	1274	1274	1169	1169	1169
Standard Supply Fan	965	965	965	1071	1071	1071
PE (Power Exhaust) Fan						
High-Static PE Fan	927	927	927	927	927	927
Standard PE Fan	619	727	727	727	727	727
Return Fan						
High-Static Return Fan	974	1086	1298	1298	1298	1298
Standard Return Fan	895	895	895	895	895	895
Supply/PE/Return Motor Includes VFD 460 Volt ODP						
7.5 Hp	183	183	183	183	183	183
10 Hp	209	209	209	209	209	209
15 Hp	320	320	320	320	320	320
20 Hp	374	374	374	374	374	374
25 Hp	417	417	417	417	417	417
30 Hp	456	456	456	456	456	456
40 Hp	697	697	697	697	697	697
50 Hp	784	784	784	784	784	784
60 Hp	897	897	897	897	897	897
75 Hp	1275	1275	1275	1275	1275	1275
100 Hp	1488	1488	1488	1488	1488	1488

OPERATING WEIGHTS OF OPTIONS AND ACCESSORIES (lb) (cont)

OPTION OR ACCESSORY	48/50N UNIT SIZE (TON NOMINAL CAPACITY)					
	N (75)	P (90)	Q (105)	R (120)	S (130)	T (150)
Supply/PE/Return Motor Includes VFD						
460 Volt TEFC						
7.5 Hp	267	267	267	267	267	267
10 Hp	283	283	283	283	283	283
15 Hp	368	368	368	368	368	368
20 Hp	437	437	437	437	437	437
25 Hp	576	576	576	576	576	576
30 Hp	604	604	604	604	604	604
40 Hp	991	991	991	991	991	991
50 Hp	925	925	925	925	925	925
60 Hp	1163	1163	1163	1163	1163	1163
75 Hp	1275	1275	1275	1275	1275	1275
100 Hp	1488	1488	1488	1488	1488	1488
Supply/PE/Return Motor Includes VFD						
575 Volt ODP						
7.5 Hp	186	186	186	186	186	186
10 Hp	204	204	204	204	204	204
15 Hp	327	327	327	327	327	327
20 Hp	369	369	369	369	369	369
25 Hp	433	433	433	433	433	433
30 Hp	456	456	456	456	456	456
40 Hp	697	697	697	697	697	697
50 Hp	784	784	784	784	784	784
60 Hp	897	897	897	897	897	897
75 Hp	1194	1194	1194	1194	1194	1194
100 Hp	1488	1488	1488	1488	1488	1488
Supply/PE/Return Motor Includes VFD						
575 Volt TEFC						
7.5 Hp	228	228	228	228	228	228
10 Hp	277	277	277	277	277	277
15 Hp	382	382	382	382	382	382
20 Hp	436	436	436	436	436	436
25 Hp	616	616	616	616	616	616
30 Hp	652	652	652	652	652	652
40 Hp	795	795	795	795	795	795
50 Hp	897	897	897	897	897	897
60 Hp	933	933	933	933	933	933
75 Hp	1194	1194	1194	1194	1194	1194
100 Hp	1488	1488	1488	1488	1488	1488
Supply/PE/Return Motor Includes VFD Bypass						
7.5 Hp	10	10	10	10	10	10
10 Hp	10	10	10	10	10	10
15 Hp	10	10	10	10	10	10
20 Hp	20	20	20	20	20	20
25 Hp	20	20	20	20	20	20
30 Hp	40	40	40	40	40	40
40 Hp	40	40	40	40	40	40
50 Hp	40	40	40	40	40	40
60 Hp	40	40	40	40	40	40
75 Hp	60	60	60	60	60	60
100 Hp	75	75	75	75	75	75
Condenser Coil Grille Guard						
Standard Efficiency	100	100	100	100	125	125
High Efficiency	100	125	125	125	125	NA
Condenser Coil Louvered Guard						
Standard Efficiency	225	225	225	225	290	290
High Efficiency	225	290	290	290	290	NA
Service Valves and Replacable Core Filter Drier	40	45	45	50	50	50
Low Ambient	50	50	50	50	50	50
UV Lights	100	100	100	130	130	130
Marine Lights	75	75	75	75	75	75
Split - 2-Piece Unit	268	268	268	280	280	280

NOTE: Please refer to E-CAT for selection.

Options and accessories



ITEM	OPTION*	ACCESSORY†	SPECIAL ORDER**
GAS HEAT (48N units only)			
Low, Medium or High Gas Heat — Aluminized Heat Exchanger	X		
Low, Medium or High Gas Heat — Stainless Steel Heat Exchanger	X		
Ultra High Gas Heat — Stainless Steel Heat Exchanger			X
Staged or Modulating Gas Heat — Stainless Steel Heat Exchanger	X		
Flue Extension		X	
ELECTRIC HEAT (50N units only)			
Low, Medium or High Electric Heat	X		
Staged or SCR Controlled Electric Heat	X		
HYDRONIC HEAT (50N units only)			
Low or High Capacity Hot Water Coil	X		
Low or High Capacity Steam Coil	X		
INDOOR AIR QUALITY			
MERV 8 Pleated, 4-in. Mixed Air Filters	X		
MERV 14 Pleated, 4-in. Mixed Air Filters	X		
MERV 14 Bag, 12-in. Mixed Air Filters with Integral 2-in. or 4-in. Prefilters	X		
MERV 15 Bag, 19-in. Mixed Air Filters with Integral 2-in. or 4-in. Prefilters	X		
MERV 14 Cartridge, 12-in. Mixed Air Filters with Integral 2-in. or 4-in. Prefilters	X		
MERV 7 2-in. Thick Filter Kit		X	
MERV 8 Pleated, 4-in. Filter Kit		X	
MERV 14 Pleated, 4-in. Filter Kit		X	
MERV 14 Bag, 12-in. Filter Kit		X	
MERV 15 Bag, 19-in. Filter Kit		X	
MERV 14 Cartridge, 12-in. Filter Kit		X	
MERV 14 Cartridge, 12-in. Final Air Filters with Integral 2-in. or 4-in. Prefilters	X		
MERV 15 Bag, 19-in. Final Air Filters with Integral 2-in. or 4-in. Prefilters	X		
MERV 17 HEPA, 12-in. Final Air Filters with Integral 2-in. or 4-in. Prefilters	X		
MERV 14 Cartridge, 12-in. Final Air Filter Kit		X	
MERV 15 Bag, 19-in. Final Air Filter Kit		X	
MERV 17 HEPA, 12-in. Final Air Filter Kit		X	
Outdoor Air cfm Measuring Station	X		
Supply Air cfm Measuring Station	X		
Exhaust Air cfm Measuring Station	X		
Agion Double-Wall Construction in Airstream	X		
Humidifier			X
ECONOMIZER			
Motorized Outdoor Air Damper	X		
Ultra Low Leak Enthalpy Control Economizer	X		
Outdoor or Return Humidity Sensor (Enthalpy)		X	
EXHAUST AIR CONTROL			
Modulating Power Exhaust with VFD	X		
Modulating Power Exhaust with VFD and Bypass	X		
High-Capacity Power Exhaust with VFD	X		
High Capacity Power Exhaust with VFD and Bypass	X		
Return Fan with VFD	X		
Return Fan with VFD and Bypass	X		
High-Capacity Return Fan with VFD	X		
High-Capacity Return Fan with VFD and Bypass	X		
Integral Shaft Grounding Ring			X
CONDENSER AND EVAPORATOR COIL			
High-Capacity Configuration	X		
High-Efficiency Configuration	X		
Al/Al E-Coat Novation® MCHX Condenser Coil	X		
Low Ambient Control	X	X	
Low Outdoor Sound	X		
E-Coat Al/Cu Evaporator Coil			X
Cu/Cu Evaporator Coil			X
Hot Gas Bypass (Circuit A)	X		
Humidi-MiZer® Adaptive Dehumidification System	X		
Condenser Coil Grille Guard	X	X	
Condenser Coil Louvered Guard	X	X	

Options and accessories (cont)



ITEM	OPTION*	ACCESSORY†	SPECIAL ORDER**
POWER CIRCUIT			
Split Power			X (exceptions may apply)
GFI Convenience Outlet (Powered on Load-Side)	X		
Power Terminal Block	X		
Non-Fused Disconnect	X		
Disconnect with UL489 Circuit Breaker (HACR)			X
Fused Disconnect			X
Phase/Voltage Protection Monitor			X
65KA Short Circuit Current Rating (460 volt)	X		
25KA Short Circuit Current Rating (575 volt only)	X		
CONTROLS			
Controls Expansion Module (CEM)	X	X	
BACnet Communication	X	X	
Dual Point Power Connection			X
ZS Sensor		With BACnet	
Equipment Touch		With BACnet	
Navigator™ Display		X	
Return Air CO ₂ Sensor		X	
CO ₂ Space Sensor		X	
Return Air Smoke Detector		X	
Return and Supply Air Smoke Detectors Installed			X
Field Use Control Box		X	X
Filter Switch		X	
Fan Status Switch (requires CEM)		X	
T-55 Space Temperature Sensor with Override		X	
T-56 Space Temperature Sensor with Override and Set Point Adjustment		X	
Space Temperature Sensor with CO ₂ Override		X	
Space Temperature Sensor with CO ₂ Override and Set Point Adjustment		X	
Modbus Carrier Translator		X	
LonWorks Carrier Translator		X	
INDOOR FAN AND MOTOR			
Constant Volume, Staged Air Volume or Variable Air Volume	X		
High-Static Indoor Fan	X		
Bypass on IFM VFD	X		
TEFC Indoor Fan Motor	X		
Indoor Fan Belt Guard	X		
Integral Shaft Grounding Ring			X
MISCELLANEOUS			
Two-piece unit	X		
Marine Lights	X		
14-in. Roof Curb		X	
Extended Lube Lines	X		
Compression			
Digital Compressor	X		
Low Compressor Sound		X	
Refrigeration Service Valves	X		
Replacable Core Filter Drier	X		
Airflow Configurations			
UV-C Lamps (with Door Interlocks and Disconnect Switch)	X		
Discharge Plenum	X		
Extended Chassis	X		
4 or 8 foot Blank Section	X		
Opposite Side Horizontal Supply			X
Side Horizontal Return			X

LEGEND

- Al** — Aluminum
- CEM** — Controls Expansion Module
- Cu** — Copper
- ETO** — Engineered-To-Order
- GFI** — Ground Fault Interrupt
- IFM** — Indoor Fan Motor
- MCHX** — Microchannel Heat Exchanger
- SCR** — Silicon-Controlled Rectifier
- UV-C** — Ultraviolet
- VFD** — Variable Frequency Drive

* Factory installed.

† Field installed.

** A special order is offered to meet specific customer requirements. Quotations for special order options can be requested via the Carrier ETO process. Lead times and prices vary with the option.

REPRESENTATIVE UNIT SELECTION UNIT SIZES 75-105

REPRESENTATIVE UNIT SELECTION UNIT SIZES 75-105



REPRESENTATIVE UNIT SECTION (EXCEPTIONS APPLY)











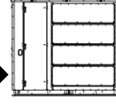
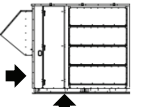
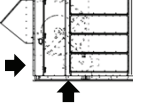
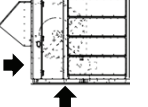
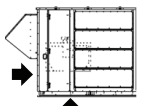
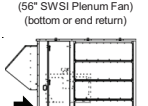

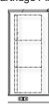

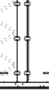
A Mandatory Return Section	B Mandatory Mixed Air Filter Section	C Mandatory DX Coil Section	D Optional Extended Chassis	E Mandatory Supply Fan	F Optional Elec/Gas Heat Section	G Optional Post Section	H Mandatory Plenum Section	J Mandatory Condensing Section
<p>4'</p> <p>Economizer with Baro Relief (bottom or end return)</p> <p>Economizer w/ Std Static PE (75T=20", 90-105T=23" FC Fan) (bottom or end return)</p> <p>Economizer w/ High Static PE (38" FC Fan) (bottom or end return)</p> <p>Economizer w/ Std Static Plenum Return Fan (40" SWSI Plenum Fan) (bottom or end return)</p> <p>Economizer w/ High Static Plenum Return Fan (75T=45", 90T=50", 105T=56" SWSI Plenum Fan) (bottom or end return)</p>	<p>Pleated Filter</p> <p>Cartridge Filters</p> <p>Bag Filters</p> <p>60" Field Use Filter Section (includes 2" pre-filters)</p>	<p>Std Evap Coil</p> <p>High Capacity Evap Coil</p>	<p>Blank Extended Chassis</p> <p>Humidi-Mizer® Dehumidification</p> <p>Hot Water Coil</p> <p>Steam Coil</p>	<p>Std Static AF Fan (28" DWDI AF)</p> <p>High Static AF Fan (40" DWDI AF)</p>	<p>Gas Heat</p> <p>Elec Heat</p>	<p>4' Blank w/Final Cartridge Filters</p> <p>8' Blank w/Final Cartridge Filters</p> <p>4' Blank w/Final Bag Filters</p> <p>8' Blank w/Final Bag Filters</p> <p>4' Blank</p> <p>8' Blank</p>	<p>Discharge Plenum (bottom or side supply, far side)</p>	<p>Std Eff Sizes: 75, 90, 105 High Eff Sizes: 75</p> <p>High Eff Sizes: 90, 105</p>

REPRESENTATIVE UNIT SELECTION UNIT SIZES 120-150

REPRESENTATIVE UNIT SELECTION UNIT SIZES 120-150

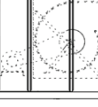
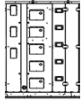
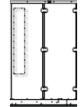
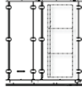
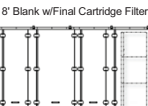
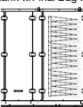

REPRESENTATIVE UNIT SECTION (EXCEPTIONS APPLY)

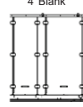
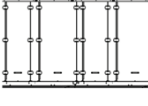
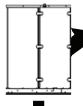
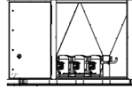
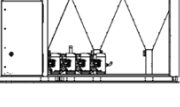
A Mandatory Return Section	B Mandatory Mixed Air Filter Section	C Mandatory DX Coil Section	D Optional Extended Chassis	E Mandatory Supply Fan	F Optional Elec/Gas Heat Section	G Optional Post Section	H Mandatory Plenum Section	J Mandatory Condensing Section
<p>4'</p>  <p>Economizer with Barometric Relief (bottom or end return)</p>  <p>Economizer w/ Std Static PE (23" FC Fan) (bottom or end return)</p>  <p>Economizer w/ High Static PE (40" FC Fan) (bottom or end return)</p>  <p>Economizer w/ Standard Static Plenum Return Fan (40" SWSI Plenum Fan) (bottom or end return)</p>  <p>Economizer w/ High Static Plenum Return Fan (56" SWSI Plenum Fan) (bottom or end return)</p> 	<p>Pleated Filter</p>  <p>Cartridge Filters</p>  <p>Bag Filters</p>  <p>60" Field Use Filter Section (includes 2" pre-filters)</p> 	<p>Std Evap Coil</p>  <p>High Capacity Evap Coil</p> 	<p>Blank Extended Chassis</p>  <p>Humid-Mizer® Dehumidification</p>  <p>Hot Water Coil</p>  <p>Steam Coil</p> 	<p>Std Static AF Fan (32" DWDI AF)</p>  <p>High Static AF Fan (40" DWDI AF)</p> 	<p>Gas Heat</p>  <p>Elec Heat</p> 	<p>4' Blank w/Final Cartridge Filters</p>  <p>8' Blank w/Final Cartridge Filters</p>  <p>4' Blank w/Final Bag Filters</p>  <p>8' Blank w/Final Bag Filters</p>  <p>4' Blank</p>  <p>8' Blank</p> 	<p>Discharge Plenum (bottom or side supply, far side)</p> 	<p>Std Eff Sizes: 120</p>  <p>Std Eff Sizes: 130, 150 High Eff Sizes: 120, 130</p> 

Chassis arrangements (48 Series units)

Standard chassis

The standard chassis may be provided with a bottom or side return air opening. The return air follows a straight-through path to the supply fan, then into the heating section and exits through a bottom or left side supply air outlet. The supply/return configuration may be mixed; e.g., bottom return with side supply. If the application utilizes an accessory roof curb, vertical ductwork is connected to the curb. When side connections are utilized, the ductwork is connected to flanges on the unit. These units are available with optional modulating power exhaust or return fan in conjunction with an optional economizer.

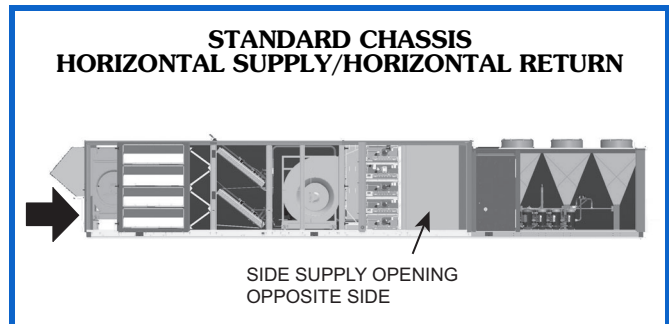
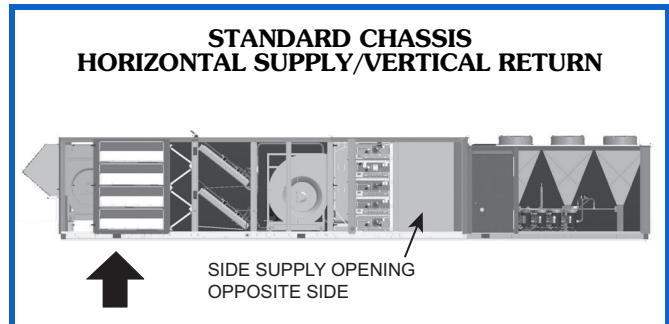
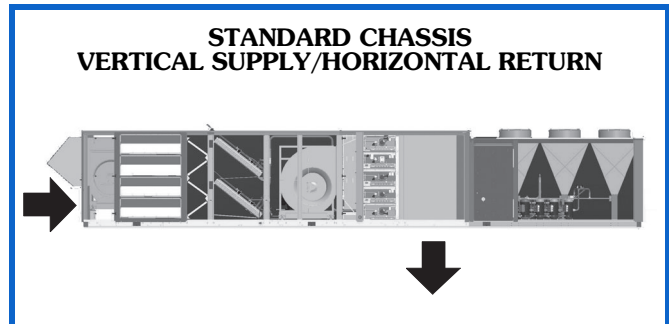
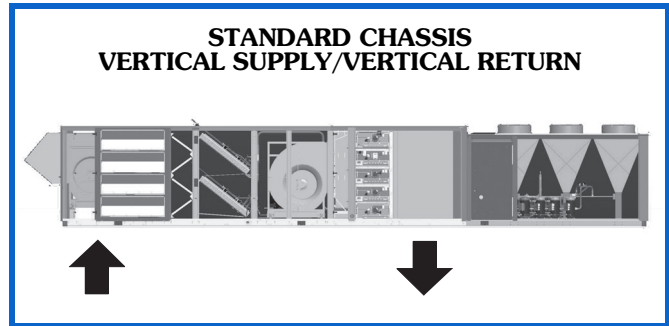

Chassis arrangements (50 Series units)

Standard chassis with discharge plenum

This configuration may be provided with a bottom or side return air opening. The return air follows a straight-through path to the supply fan. The supply fan is arranged for horizontal outlet into the discharge plenum area. Supply air exits from the discharge plenum area downward through the bottom of the unit or horizontally through the left side outlet. The supply/return configuration may be mixed; e.g., bottom return with side supply. If the application utilizes an accessory roof curb, vertical ductwork is connected to the curb. When side connections are utilized, the ductwork is connected to flanges on the unit. These units are available with optional modulating power exhaust or return fan in conjunction with an optional economizer. Factory-installed optional electric heat is available on these units.

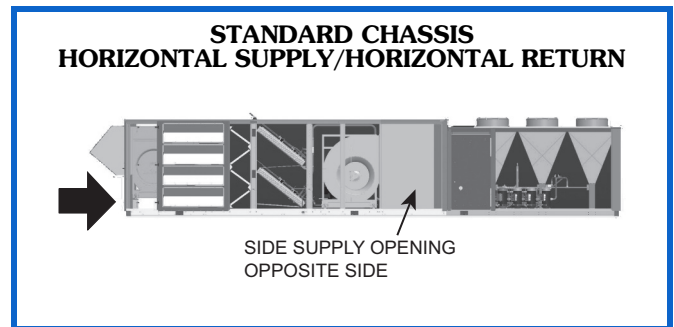
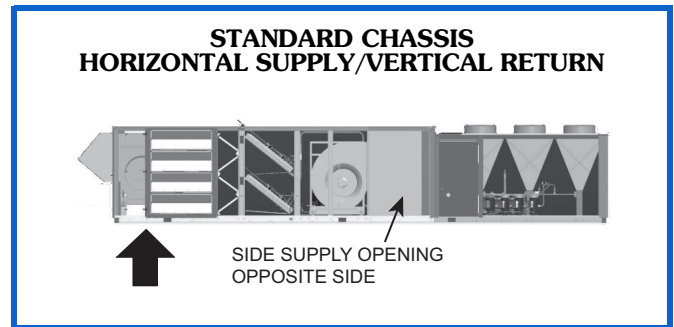
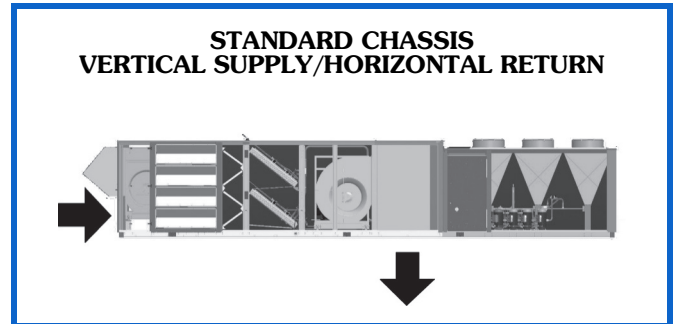
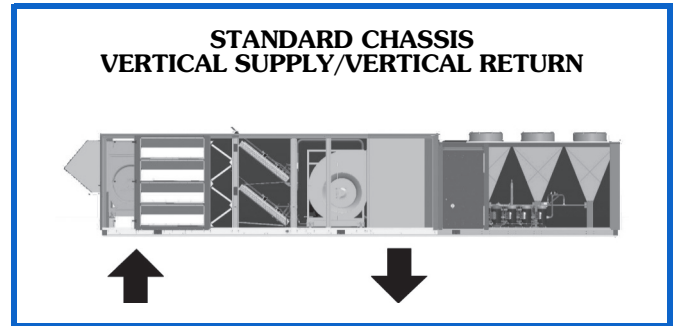

Standard chassis with discharge plenum and optional blank section or final filters

This configuration may be provided with a bottom or side return air opening. The return air follows a straight-through path to the supply fan. The supply fan is arranged for horizontal outlet into the discharge plenum area. Supply air exits from the discharge plenum area, through the blank section or final filters, then through the bottom or left side supply air outlet. The supply/return configuration may be mixed; e.g., bottom return with side supply. If the application utilizes an accessory roof curb, vertical ductwork is connected to the curb. When side connections are utilized, the ductwork is connected to flanges on the unit. Factory-installed optional electric heat is available on these units.

Extended length chassis with discharge plenum

This configuration may be provided with a bottom or side return air opening. The extended length chassis arrangement provides an additional 25 in. of unit length located between the evaporator coil section and the supply fan sled. This compartment is used for the Humidi-MiZer coil or may also be used for field-installation of an auxiliary coil; e.g., a refrigeration heat reclaim coil. The supply fan is arranged for horizontal outlet into the discharge plenum area. Supply air exits from the discharge plenum area downward through the bottom of the unit or horizontally through the left side outlet. The supply/return configuration may be mixed; e.g., bottom return with side supply. If the application utilizes an accessory roof curb, vertical ductwork is connected to the curb. When side connections are utilized, the ductwork is connected to flanges on the unit. These units are available with optional modulating power exhaust in conjunction with an optional economizer.

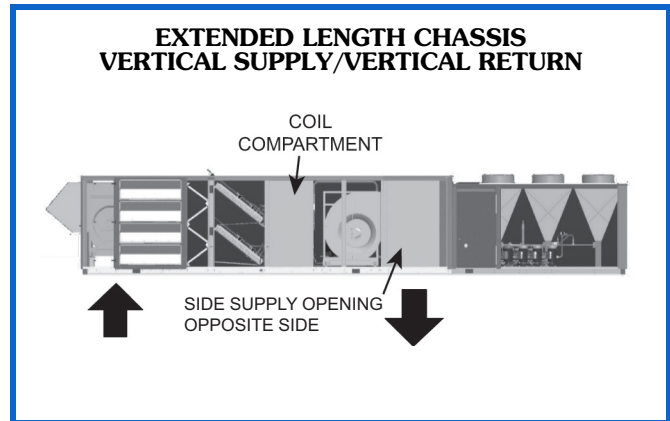
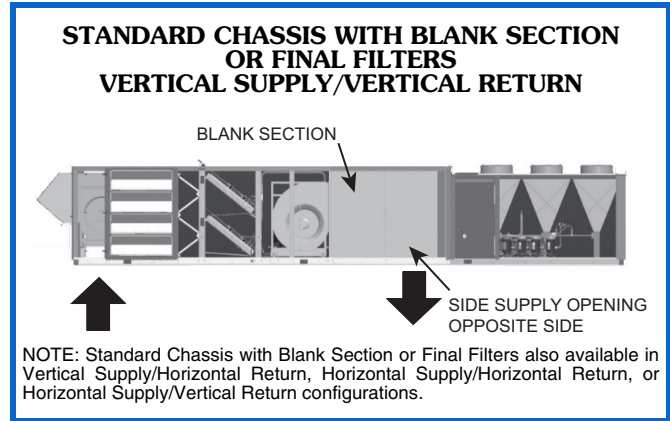

48N UNIT SIZES N, P, Q (75-105 TON NOMINAL CAPACITY)

NOTES:
1. DIMENSIONS ARE IN INCHES.

2. UNIT WEIGHT AND CENTER OF GRAVITY INCLUDES ECONOMIZER, RECLAIM COIL, MOTOR AND HIGH CAPACITY EVAPORATOR COIL.

3. UNIT CLEARANCES:

TOP - DO NOT RESTRICT CONDENSER FANS

ECONOMIZER END - 10'-0" - 6" - 0"

FOR SMOKE EXHAUST AND OPERATIONAL CLEARANCES, CONTACT

CARRIER APPLICATION ENGINEERING DEPARTMENT.

4. SUGGESTED FIELD CONNECTIONS TO MADE INSIDE OR OUTSIDE

OF DUCT FLANGES

5. CONDENSATE DRAIN TRAP

6. ECONOMIZER SIDE HOODS ARE SHIPPED INSIDE OF UNIT.

7. HEAT RECLAIM COIL DIMENSIONS (MAXIMUM):

- WIDTH: 6'-0"

- HEIGHT: 64'-50"

8. HEAT RECLAIM COIL FIELD SUPPLIED OR

PIPE LOCATIONS ARE RECOMMENDATIONS ONLY.

9. PIPE MASS LOCATIONS ARE NOT FACTORY PROVIDED.

10. OPERATIONAL FACTORY SUPPLIED HOT WATER AND

STEAM COILS ON UNITS WITHOUT ELECTRIC HEAT.

- LENGTH: 108'-75" WIDTH: 6'-00" HEIGHT: 64'-50"

- TUBE O. D.: 1 1/2" - ROWS 2

PIPE SIZE: 1 1/2" - NPT

5' LENGTH: 110'-00" WIDTH: 5'-00" HEIGHT: 54'-00"

- TUBE O. D.: 1'-00" - ROWS 2

PIPE SIZE: 2 1/2" - NPT

5' LENGTH: 110'-00" WIDTH: 5'-00" HEIGHT: 54'-00"

POST FILTER OPTION: THE POST FILTERS ARE

INSTALLED IN THE BLANK SECTION AS FAR DOWNSTREAM

AS POSSIBLE, ADJACENT TO THE DISCHARGE PLENUM.

THERE IS NO AVAILABLE SPACE BETWEEN THE POST FILTERS

AND THE DISCHARGE OPENING.

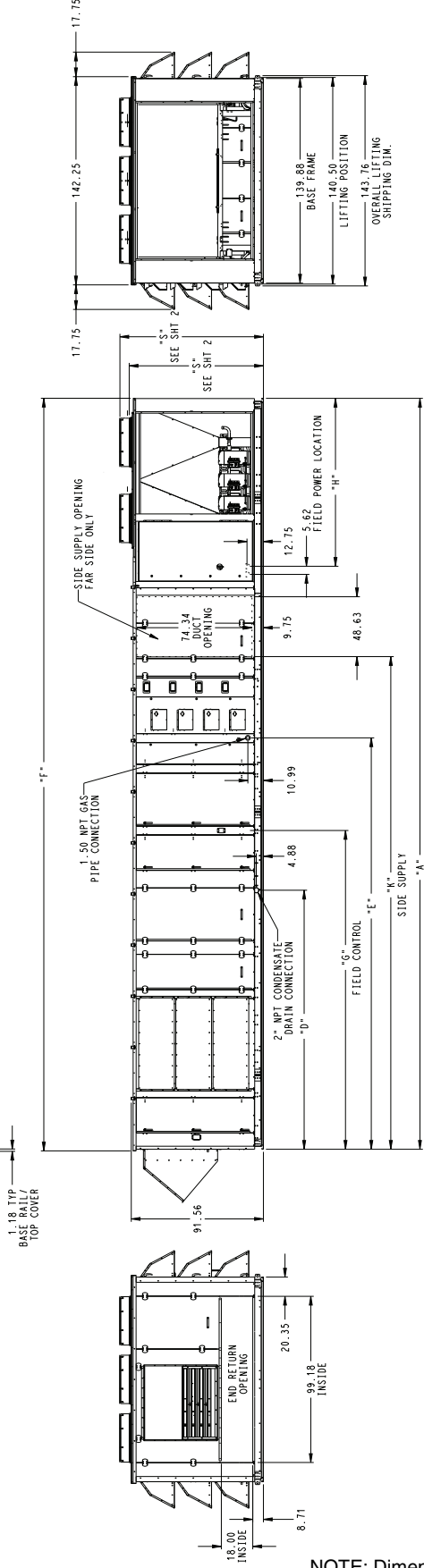
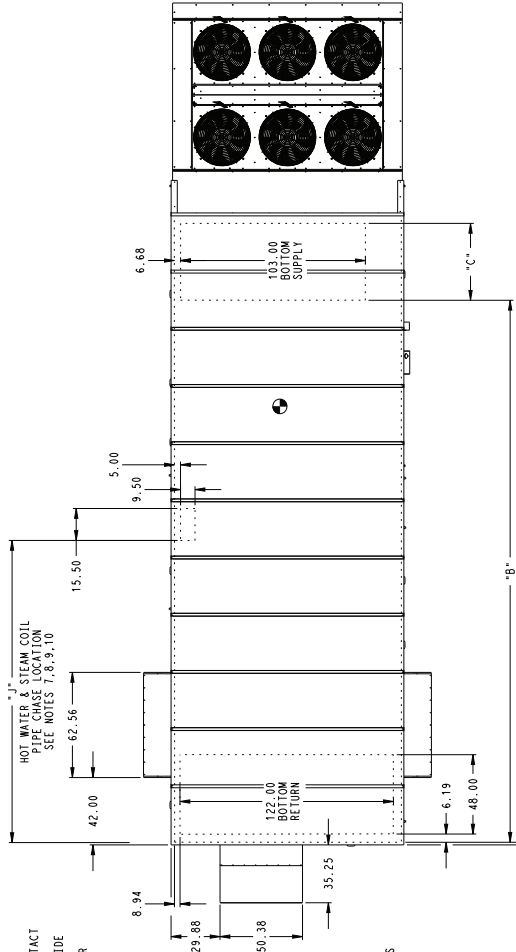
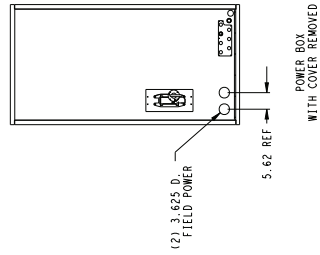

NOTE: Dimensions are in inches.

Base unit dimensions (cont)



48N UNIT SIZES N, P, Q (75-105 TON NOMINAL CAPACITY)

NOMINAL CAPACITY/ EFFICIENCY	EXTENDED CHASSIS	SUPPLY FAN	FIELD USE FILTER SECTION	BLANK SECTION	2-PIECE UNIT	COND	A	B	C	D	E	F	G	H	J	K		
75 ALL 90 STD EFF 105 STD EFF	NO	STD	NO	NO	NO	2	498.11	314.42	48	177.02	266.07	499.35	202.75	119.76	—	313.36		
				4 FT	YES	2	564.61	380.92	48	195.27	284.32	565.85	221.00	119.76	—	379.86		
				8 FT	YES	2	612.86	429.17	48	195.27	284.32	614.10	221.00	119.76	—	428.11		
			YES	NO	YES	2	576.86	393.17	48	255.77	344.82	578.10	281.50	119.76	—	392.11		
				4 FT	YES	2	625.11	441.42	48	255.77	344.82	626.35	281.50	119.76	—	440.36		
				8 FT	YES	2	673.36	489.67	48	255.77	344.82	674.60	281.50	119.76	—	488.61		
		4 FT	YES	2	579.70	396.01	48	195.27	299.41	580.94	236.09	119.76	—	394.95				
		8 FT	YES	2	627.95	444.26	48	195.27	299.41	629.19	236.09	119.76	—	443.20				
		4 FT	YES	2	640.20	456.51	48	255.77	359.91	641.44	296.59	119.76	—	455.45				
		8 FT	YES	2	688.45	504.76	48	255.77	359.91	689.69	296.59	119.76	—	503.70				
		YES	STD	NO	NO	NO	2	522.11	338.42	48	177.02	290.07	523.35	226.75	119.76	185.75	337.36	
					4 FT	YES	2	588.61	404.92	48	195.27	308.32	589.85	245.00	119.76	204.00	403.86	
	8 FT				YES	2	636.86	453.17	48	195.27	308.32	638.10	245.00	119.76	204.00	452.11		
	4 FT			YES	2	649.11	465.42	48	255.77	368.82	650.35	305.50	119.76	264.50	464.36			
	8 FT			YES	2	697.36	513.67	48	255.77	368.82	698.60	305.50	119.76	264.50	512.61			
	4 FT			YES	2	603.70	420.01	48	195.27	323.41	604.94	260.09	119.76	204.00	418.95			
	8 FT		YES	2	651.95	468.26	48	195.27	323.41	653.19	260.09	119.76	204.00	467.20				
	4 FT		YES	2	664.20	480.51	48	255.77	383.91	665.44	320.59	119.76	264.50	479.45				
	8 FT		YES	2	712.45	528.76	48	255.77	383.91	713.69	320.59	119.76	264.50	527.70				
	90 HI EFF 105 HI EFF		NO	STD	NO	NO	NO	3	550.11	314.42	48	177.02	266.07	551.35	202.75	171.76	—	313.36
						4 FT	YES	3	616.61	380.92	48	195.27	284.32	617.85	221.00	171.76	—	379.86
						8 FT	YES	3	664.86	429.17	48	195.27	284.32	666.10	221.00	171.76	—	428.11
		4 FT			YES	3	677.11	441.42	48	255.77	344.82	678.35	281.50	171.76	—	440.36		
		8 FT			YES	3	725.36	489.67	48	255.77	344.82	726.60	281.50	171.76	—	488.61		
4 FT		YES			3	631.70	396.01	48	195.27	299.41	632.94	236.09	171.76	—	394.95			
8 FT		YES		3	679.95	444.26	48	195.27	299.41	681.19	236.09	171.76	—	443.20				
4 FT		YES		3	692.20	456.51	48	255.77	359.91	693.44	296.59	171.76	—	455.45				
8 FT		YES		3	740.45	504.76	48	255.77	359.91	741.69	296.59	171.76	—	503.70				
YES		STD		NO	NO	NO	3	574.11	338.42	48	177.02	290.07	575.35	226.75	171.76	185.75	337.36	
					4 FT	YES	3	640.61	404.92	48	195.27	308.32	641.85	245.00	171.76	204.00	403.86	
					8 FT	YES	3	688.86	453.17	48	195.27	308.32	690.10	245.00	171.76	204.00	452.11	
			4 FT	YES	3	701.11	465.42	48	255.77	368.82	702.35	305.50	171.76	264.50	464.36			
			8 FT	YES	3	749.36	513.67	48	255.77	368.82	750.60	305.50	171.76	264.50	512.61			
			4 FT	YES	3	655.70	420.01	48	195.27	323.41	656.94	260.09	171.76	204.00	418.95			
		8 FT	YES	3	703.95	468.26	48	195.27	323.41	705.19	260.09	171.76	204.00	467.20				
		4 FT	YES	3	716.20	480.51	48	255.77	383.91	717.44	320.59	171.76	264.50	479.45				
		8 FT	YES	3	764.45	528.76	48	255.77	383.91	765.69	320.59	171.76	264.50	527.70				

48N CONDENSER DETAIL SIZES N, P, Q (75-105 TON NOMINAL CAPACITY)

NOMINAL CAPACITY/EFFICIENCY	COND COILS 2V	COND COIL 3V	LOW SOUND	DIMENSION "S"
75 ALL	YES	—	NO	92.62
75 ALL	YES	—	YES	98.06
90 STANDARD EFFICIENCY	YES	—	NO	92.62
90 HIGH EFFICIENCY	—	YES	YES	98.06
90 STANDARD EFFICIENCY	YES	—	YES	98.06
105 STANDARD EFFICIENCY	YES	—	NO	98.06
105 HIGH EFFICIENCY	—	YES	YES	98.06
105 STANDARD EFFICIENCY	YES	—	YES	98.06

Base unit dimensions (cont)



48N UNIT SIZES R, S, T (120-150 TON NOMINAL CAPACITY)

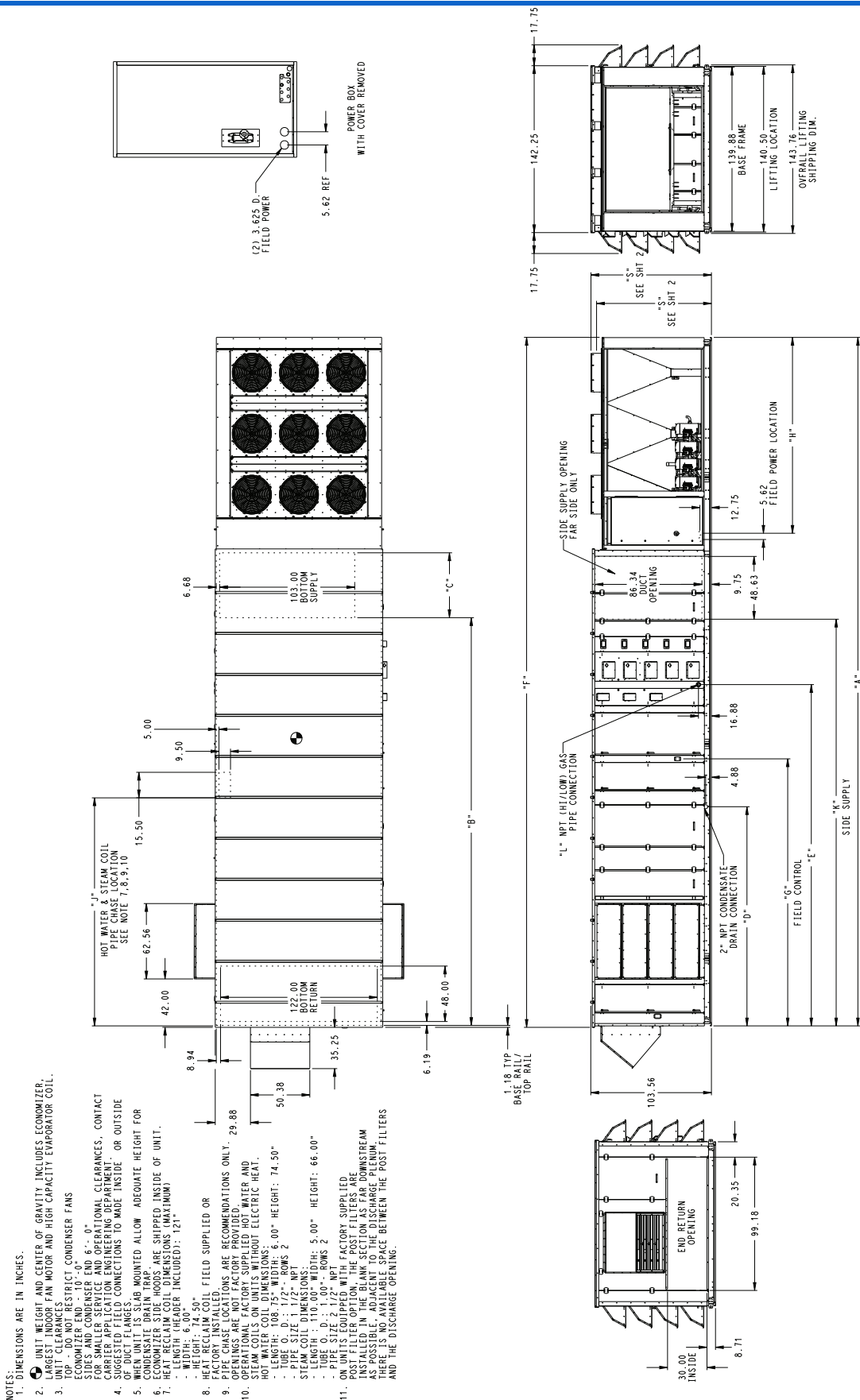

- NOTES:
1. DIMENSIONS ARE IN INCHES.
 2. UNIT WEIGHT AND CENTER OF GRAVITY INCLUDES ECONOMIZER.
 3. LARGEST INDOOR FAN MOTOR AND HIGH CAPACITY EVAPORATOR COIL.
 4. UNIT CLEARANCES STRICT CONDENSER FANS.
 5. ECONOMIZER END - 10'-0"
 6. SIDES AND CONDENSER END 6'-0"
 7. FOR SMALLER SERVICE AND OPERATIONAL CLEARANCES, CONTACT FACTORY FOR SUGGESTED FIELD CONNECTIONS TO MADE INSIDE OR OUTSIDE OF DUCT FLANGES.
 8. WHEN UNIT IS SLAB MOUNTED ALLOW ADEQUATE HEIGHT FOR ECONOMIZER SIDE HOODS.
 9. ECONOMIZER SIDE HOODS ARE SHIPPED INSIDE OF UNIT.
 10. HEAT RECLAIM COIL DIMENSIONS (MAXIMUM)
 - LENGTH (HEADER INCLUDED): 121"
 - WIDTH: 6'-0"
 - HEIGHT: 6'-0"
 11. HEAT RECLAIM COIL FIELD SUPPLIED OR FACTORY INSTALLED.
 12. PIPE CHASE LOCATIONS ARE RECOMMENDATIONS ONLY. 29.88
 13. OPERATIONAL FACTORY SUPPLIED HOT WATER AND STEAM COILS ON UNITS WITHOUT ELECTRIC HEAT.
 14. HOT WATER COIL DIMENSIONS:
 - LENGTH: 106.72"
 - WIDTH: 6'-0"
 - HEIGHT: 74.50"
 15. STEAM COIL DIMENSIONS:
 - LENGTH: 110.00"
 - WIDTH: 5'-0"
 - HEIGHT: 66.00"
 16. POST FILTER OPTION, THE POST FILTERS ARE SUPPLIED IN THE DOWNSTREAM AS POSSIBLE IN ADJACENCE TO THE DISCHARGE PLENUM THERE IS NO AVAILABLE SPACE BETWEEN THE POST FILTERS AND THE DISCHARGE OPENING.

NOTE: Dimensions are in inches.

Base unit dimensions (cont)



48N UNIT SIZES R, S, T (120-150 TON NOMINAL CAPACITY)

NOMINAL CAPACITY/ EFFICIENCY	EXTENDED CHASSIS	HIGH GAS HEAT*	FIELD USE FILTER SECTION	BLANK SECTION	2-PIECE UNIT	COND	A	B	C	D	E	F	G	H	J	K	L HI	L MED LOW	
120 STD EFF	NO	NO	NO	NO	NO	2	523.04	339.35	48	186.86	291.00	524.28	227.68	119.76	—	338.29	2	1.5	
				4 FT	YES	2	589.54	405.85	48	205.11	309.25	590.78	245.93	119.76	—	404.79	2	1.5	
				8 FT	YES	2	637.79	454.10	48	205.11	309.25	639.03	245.93	119.76	—	453.04	2	1.5	
			NO	YES	2	601.79	418.10	48	265.61	369.75	603.03	306.43	119.76	—	417.04	2	1.5		
			4 FT	YES	2	650.04	466.35	48	265.61	369.75	651.28	306.43	119.76	—	465.29	2	1.5		
			8 FT	YES	2	698.29	514.60	48	265.61	369.75	699.53	306.43	119.76	—	513.54	2	1.5		
		YES	NO	NO	2	535.04	339.35	60	186.86	291.00	536.28	227.68	119.76	—	—	2	—		
			4 FT	YES	2	601.54	405.85	60	205.11	309.25	602.78	245.93	119.76	—	—	2	—		
			8 FT	YES	2	649.79	454.10	60	205.11	309.25	651.03	245.93	119.76	—	—	2	—		
			NO	YES	2	613.79	418.10	60	265.61	369.75	615.03	306.43	119.76	—	—	2	—		
			4 FT	YES	2	662.04	466.35	60	265.61	369.75	663.28	306.43	119.76	—	—	2	—		
			8 FT	YES	2	710.29	514.60	60	265.61	369.75	711.53	306.43	119.76	—	—	2	—		
	YES	NO	NO	NO	NO	2	547.04	363.35	48	186.86	315.00	548.28	251.68	119.76	195.56	362.29	2	1.5	
				4 FT	YES	2	613.54	429.85	48	205.11	333.25	614.78	269.93	119.76	213.81	428.79	2	1.5	
				8 FT	YES	2	661.79	478.10	48	205.11	333.25	663.03	269.93	119.76	213.81	477.04	2	1.5	
			NO	YES	2	625.79	442.10	48	265.61	393.75	627.03	330.43	119.76	274.31	441.04	2	1.5		
			4 FT	YES	2	674.04	490.35	48	265.61	393.75	675.28	330.43	119.76	274.31	489.29	2	1.5		
			8 FT	YES	2	722.29	538.60	48	265.61	393.75	723.53	330.43	119.76	274.31	537.54	2	1.5		
		YES	NO	NO	2	559.04	363.35	60	186.86	315.00	560.28	251.68	119.76	195.56	—	2	—		
			4 FT	YES	2	625.54	429.85	60	205.11	333.25	626.78	269.93	119.76	213.81	—	2	—		
			8 FT	YES	2	673.79	478.10	60	205.11	333.25	675.03	269.93	119.76	213.81	—	2	—		
			NO	YES	2	637.79	442.10	60	265.61	393.75	639.03	330.43	119.76	274.31	—	2	—		
			4 FT	YES	2	686.04	490.35	60	265.61	393.75	687.28	330.43	119.76	274.31	—	2	—		
			8 FT	YES	2	734.29	538.60	60	265.61	393.75	735.53	330.43	119.76	274.31	—	2	—		
	120 HI EFF 130 ALL 150 STD EFF	NO	NO	NO	NO	NO	3	575.04	339.35	48	186.86	291.00	576.28	227.68	171.76	—	338.29	2	1.5
					4 FT	YES	3	641.54	405.85	48	205.11	309.25	642.78	245.93	171.76	—	404.79	2	1.5
					8 FT	YES	3	689.79	454.10	48	205.11	309.25	691.03	245.93	171.76	—	453.04	2	1.5
				NO	YES	3	653.79	418.10	48	265.61	369.75	655.03	306.43	171.76	—	417.04	2	1.5	
				4 FT	YES	3	702.04	466.35	48	265.61	369.75	703.28	306.43	171.76	—	465.29	2	1.5	
				8 FT	YES	3	750.29	514.60	48	265.61	369.75	751.53	306.43	171.76	—	513.54	2	1.5	
			YES	NO	NO	3	587.04	339.35	60	186.86	291.00	588.28	227.68	171.76	—	—	2	—	
				4 FT	YES	3	653.54	405.85	60	205.11	309.25	654.78	245.93	171.76	—	—	2	—	
				8 FT	YES	3	701.79	454.10	60	205.11	309.25	703.03	245.93	171.76	—	—	2	—	
				NO	YES	3	665.79	418.10	60	265.61	369.75	667.03	306.43	171.76	—	—	2	—	
				4 FT	YES	3	714.04	466.35	60	265.61	369.75	715.28	306.43	171.76	—	—	2	—	
				8 FT	YES	3	762.29	514.60	60	265.61	369.75	763.53	306.43	171.76	—	—	2	—	
YES		NO	NO	NO	NO	3	599.04	363.35	48	186.86	315.00	600.28	251.68	171.76	195.56	362.29	2	1.5	
				4 FT	YES	3	665.54	429.85	48	205.11	333.25	666.78	269.93	171.76	213.81	428.79	2	1.5	
				8 FT	YES	3	713.79	478.10	48	205.11	333.25	715.03	269.93	171.76	213.81	477.04	2	1.5	
			NO	YES	3	677.79	442.10	48	265.61	393.75	679.03	330.43	171.76	274.31	441.04	2	1.5		
			4 FT	YES	3	726.04	490.35	48	265.61	393.75	727.28	330.43	171.76	274.31	489.29	2	1.5		
			8 FT	YES	3	774.29	538.60	48	265.61	393.75	775.53	330.43	171.76	274.31	537.54	2	1.5		
		YES	NO	YES	3	629.29	381.60	60	205.11	333.25	630.53	269.93	171.76	213.81	—	2	—		
			4 FT	YES	3	677.54	429.85	60	205.11	333.25	678.78	269.93	171.76	213.81	—	2	—		
			8 FT	YES	3	725.79	478.10	60	205.11	333.25	727.03	269.93	171.76	213.81	—	2	—		
			NO	YES	3	689.79	442.10	60	265.61	393.75	691.03	330.43	171.76	274.31	—	2	—		
			4 FT	YES	3	738.04	490.35	60	265.61	393.75	739.28	330.43	171.76	274.31	—	2	—		
			8 FT	YES	3	786.29	538.60	60	265.61	393.75	787.53	330.43	171.76	274.31	—	2	—		

*Vertical discharge only.

48N CONDENSER DETAIL SIZES R, S, T (120-150 TON NOMINAL CAPACITY)

NOMINAL CAPACITY/EFFICIENCY	COND COILS 2V	COND COIL 3V	LOW SOUND	DIMENSION "S"
120 STANDARD EFFICIENCY	YES	—	NO	96.62
120 HIGH EFFICIENCY	—	YES	YES	102.06
120 STANDARD EFFICIENCY	YES	—	YES	102.06
130 STANDARD EFFICIENCY	—	YES	NO	96.62
130 HIGH EFFICIENCY	—	YES	YES	102.06
150 STANDARD EFFICIENCY	—	YES	YES	102.06

Base unit dimensions (cont)



50N UNITS SIZES N, P, Q (75-105 TON NOMINAL CAPACITY)

NOTES:

1. DIMENSIONS ARE IN INCHES.
2. UNIT WEIGHT AND CENTER OF GRAVITY INCLUDES ECONOMIZER, RECLAIM COIL, EXHAUST FAN MOTOR AND HIGH CAPACITY EXHAUSTOR COIL.
3. UNIT CLEARANCES
4. TOP - DO NOT RESTRICT CONDENSER FANS
5. ECONOMIZER END - 10'-0" - 6'-0" FOR SMALLER SERVICE AND OPERATIONAL CLEARANCES. CONTACT CARRIER APPLICATION SERVICE AND OPERATIONAL CLEARANCES. CONTACT CARRIER APPLICATION SERVICE AND OPERATIONAL CLEARANCES. CONTACT CARRIER APPLICATION SERVICE AND OPERATIONAL CLEARANCES.
6. SUGGESTED FIELD CONNECTIONS TO MADE INSIDE OR OUTSIDE
7. W/ UNIT LIFTING BAR MOUNTED ALLOW ADEQUATE HEIGHT FOR CONDENSATE DRAIN TRAP.
8. ECONOMIZER SIDE HOODS ARE SHIPPED INSIDE OF UNIT.
9. HEAT RECLAIM COIL DIMENSIONS (MAXIMUM)
 - LENGTH: 108.75" - WIDTH: 6.00" - HEIGHT: 64.50"
 - TUBE O. D.: 1.72" - ROWS: 2
 - TUBE O. D.: 1.72" - ROWS: 2
 - LENGTH: 110.00" - WIDTH: 5.00" - HEIGHT: 54.00"
 - TUBE O. D.: 1.00" - ROWS: 2
10. HEAT RECLAIM COIL FIELD SUPPLIED OR
 - HEIGHT: 64.50"
 - TUBE O. D.: 1.72" - ROWS: 2
 - LENGTH: 110.00" - WIDTH: 5.00" - HEIGHT: 54.00"
 - TUBE O. D.: 1.00" - ROWS: 2
11. ON PIPE SIZE 1/2" NPT FACTORY SUPPLIED POST FILTER OPTION. THE POST FILTERS ARE INSTALLED IN THE BLANK SECTION AS FAR DOWNSTREAM AS POSSIBLE. ADJACENT TO THE DISCHARGE PLENUM. THE POST FILTERS ARE TO BE INSTALLED IN THE BLANK SECTION AS FAR DOWNSTREAM AS POSSIBLE. ADJACENT TO THE DISCHARGE PLENUM. THE POST FILTERS ARE TO BE INSTALLED IN THE BLANK SECTION AS FAR DOWNSTREAM AS POSSIBLE. ADJACENT TO THE DISCHARGE PLENUM.

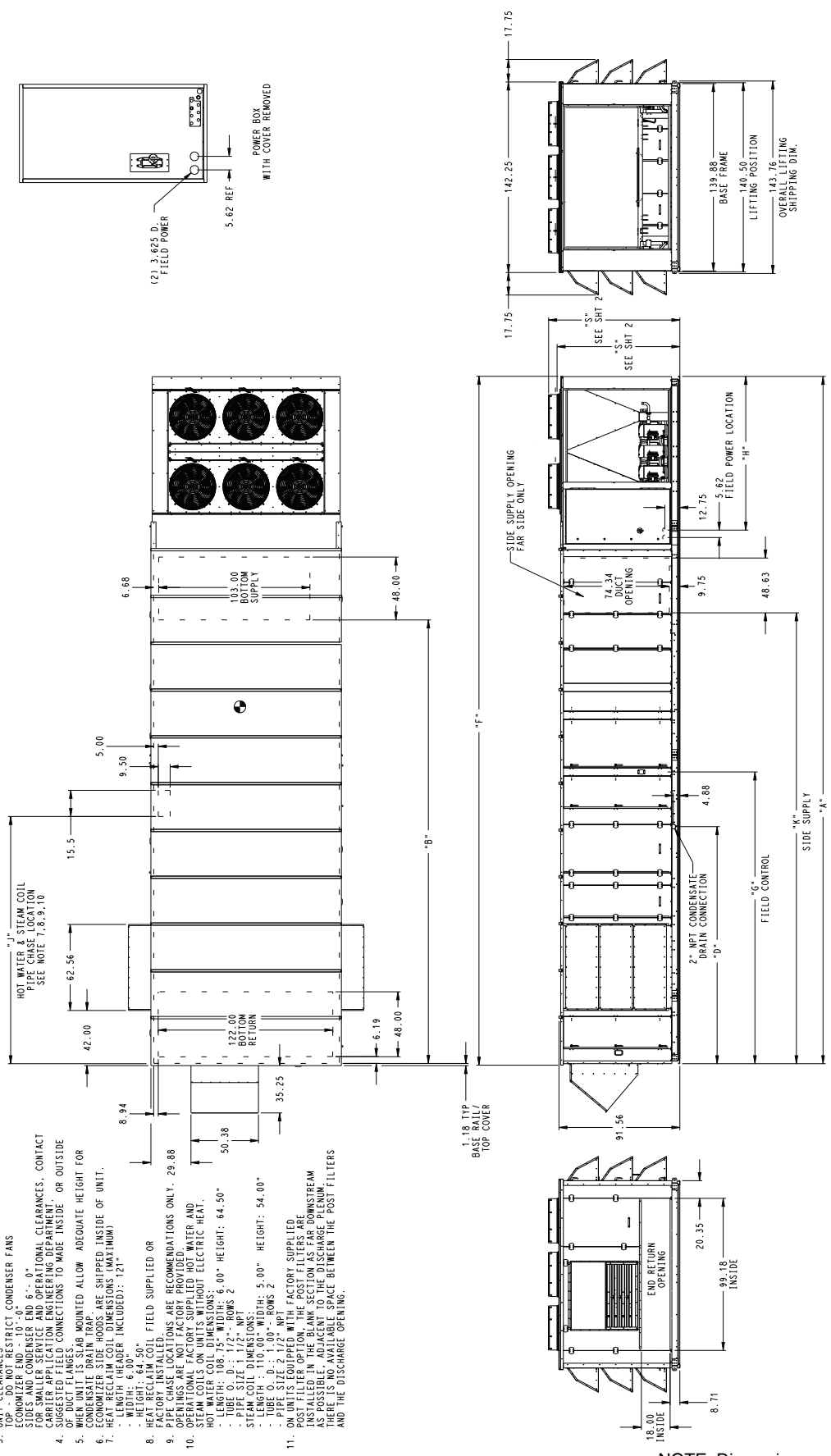

NOTE: Dimensions are in inches.

Base unit dimensions (cont)



50N UNIT SIZES N, P, Q (75-105 TON NOMINAL CAPACITY)

NOMINAL CAPACITY/ EFFICIENCY	EXTENDED CHASSIS	SUPPLY FAN	FIELD USE FILTER SECTION	BLANK SECTION	2-PIECE UNIT	COND	A	B	D	F	G	H	J	K
75 ALL 90 STD EFF 105 STF EFF	NO	STD	NO	NO	NO	2	433.11	249.42	177.02	434.35	202.75	119.76	—	248.36
				4 FT	YES	2	556.36	372.67	195.27	557.60	221.00	119.76	—	371.61
				8 FT	YES	2	604.61	420.92	195.27	605.85	221.00	119.76	—	419.86
			YES	NO	NO	2	493.61	309.92	237.52	494.85	263.25	119.76	—	308.86
				4 FT	YES	2	616.86	433.17	255.77	618.10	281.50	119.76	—	432.11
				8 FT	YES	2	665.11	481.42	255.77	666.35	281.50	119.76	—	480.36
		HIGH	NO	NO	NO	2	448.20	264.51	177.02	449.44	217.84	119.76	—	263.45
				4 FT	YES	2	571.45	387.76	195.27	572.69	236.09	119.76	—	386.70
				8 FT	YES	2	619.70	436.01	195.27	620.94	236.09	119.76	—	434.95
			YES	NO	NO	2	508.70	325.01	237.52	509.94	278.34	119.76	—	323.95
				4 FT	YES	2	631.95	448.26	255.77	633.19	296.59	119.76	—	447.20
				8 FT	YES	2	680.20	496.51	255.77	681.44	296.59	119.76	—	495.45
	YES	STD	NO	NO	NO	2	457.11	273.42	177.02	458.35	226.75	119.76	185.75	272.36
				4 FT	YES	2	580.36	396.67	195.27	581.60	245.00	119.76	204.00	395.61
				8 FT	YES	2	628.61	444.92	195.27	629.85	245.00	119.76	204.00	443.86
			YES	NO	NO	2	517.61	333.92	237.52	518.85	287.25	119.76	246.25	332.86
				4 FT	YES	2	640.86	457.17	255.77	642.10	305.50	119.76	264.50	456.11
				8 FT	YES	2	689.11	505.42	255.77	690.35	305.50	119.76	264.50	504.36
		HIGH	NO	NO	NO	2	472.20	288.51	177.02	473.44	241.84	119.76	185.75	287.45
				4 FT	YES	2	595.45	411.76	195.27	596.69	260.09	119.76	204.00	410.70
				8 FT	YES	2	643.70	460.01	195.27	644.94	260.09	119.76	204.00	458.95
			YES	NO	NO	2	532.70	349.01	237.52	533.94	302.34	119.76	246.25	347.95
				4 FT	YES	2	655.95	472.26	255.77	657.19	320.59	119.76	264.50	471.20
				8 FT	YES	2	704.20	520.51	255.77	705.44	320.59	119.76	264.50	519.45
90 HI EFF 105 HI EFF	NO	STD	NO	NO	NO	3	485.11	249.42	177.02	486.35	202.75	171.76	—	248.36
				4 FT	YES	3	608.36	372.67	195.27	609.60	221.00	171.76	—	371.61
				8 FT	YES	3	656.61	420.92	195.27	657.85	221.00	171.76	—	419.86
			YES	NO	NO	3	545.61	309.92	237.52	546.85	263.25	171.76	—	308.86
				4 FT	YES	3	668.86	433.17	255.77	670.10	281.50	171.76	—	432.11
				8 FT	YES	3	717.11	481.42	255.77	718.35	281.50	171.76	—	480.36
		HIGH	NO	NO	NO	3	500.20	264.51	177.02	501.44	217.84	171.76	—	263.45
				4 FT	YES	3	623.45	387.76	195.27	624.69	236.09	171.76	—	386.70
				8 FT	YES	3	671.70	436.01	195.27	672.94	236.09	171.76	—	434.95
			YES	NO	NO	3	560.70	325.01	237.52	561.94	278.34	171.76	—	323.95
				4 FT	YES	3	683.95	448.26	255.77	685.19	296.59	171.76	—	447.20
				8 FT	YES	3	732.20	496.51	255.77	733.44	296.59	171.76	—	495.45
	YES	STD	NO	NO	NO	3	509.11	273.42	177.02	510.35	226.75	171.76	185.75	272.36
				4 FT	YES	3	632.36	396.67	195.27	633.60	245.00	171.76	204.00	395.61
				8 FT	YES	3	680.61	444.92	195.27	681.85	245.00	171.76	204.00	443.86
			YES	NO	NO	3	569.61	333.92	237.52	570.85	287.25	171.76	264.50	332.86
				4 FT	YES	3	692.86	457.17	255.77	694.10	305.50	171.76	264.50	456.11
				8 FT	YES	3	741.11	505.42	255.77	742.35	305.50	171.76	264.50	504.36
		HIGH	NO	NO	NO	3	524.20	288.51	177.02	525.44	241.84	171.76	185.75	287.45
				4 FT	YES	3	647.45	411.76	195.27	648.69	260.09	171.76	204.00	410.70
				8 FT	YES	3	695.70	460.01	195.27	696.94	260.09	171.76	204.00	458.95
			YES	NO	NO	3	584.70	349.01	237.52	585.94	302.34	171.76	246.25	347.95
				4 FT	YES	3	707.95	472.26	255.77	709.19	320.59	171.76	264.50	471.20
				8 FT	YES	3	756.20	520.51	255.77	757.44	320.59	171.76	264.50	519.45

50N CONDENSER DETAIL SIZES N, P, Q (75-105 TON NOMINAL CAPACITY)

NOMINAL CAPACITY/EFFICIENCY	COND COILS 2V	COND COIL 3V	LOW SOUND	DIMENSION "S"
75 ALL	YES	—	NO	92.62
75 ALL	YES	—	YES	98.06
90 STANDARD EFFICIENCY	YES	—	NO	92.62
90 HIGH EFFICIENCY	—	YES	YES	98.06
90 STANDARD EFFICIENCY	YES	—	YES	98.06
105 STANDARD EFFICIENCY	YES	—	NO	98.06
105 HIGH EFFICIENCY	—	YES	YES	98.06
105 STANDARD EFFICIENCY	YES	—	YES	98.06

Base unit dimensions (cont)



50N UNITS SIZES R, S, T (120-150 TON NOMINAL CAPACITY)

NOTES:
1. DIMENSIONS ARE IN INCHES.

2. UNIT WEIGHT AND CENTER OF GRAVITY INCLUDES ECONOMIZER.
3. LARGEST INDOOR FAN MOTOR AND HIGH CAPACITY EVAPORATOR COIL. DIMENSIONS ARE TO THE CENTERLINE OF THE MOTOR.
4. ECONOMIZER END - 10'-0" SIDES AND CONDENSER END 6'-0" SIDES. CONTACT CARRIER REPRESENTATIVE FOR CLEARANCES, CONTACT CARRIER REPRESENTATIVE FOR OPERATING CLEARANCES.
5. SUGGESTED FIELD CONNECTIONS TO MAKE INSIDE OR OUTSIDE OF DUCT FLANGES.
6. WHEN UNIT IS SLAB MOUNTED ALLOW ADEQUATE HEIGHT FOR ECONOMIZER AND CONDENSER.
7. ECONOMIZER SIDE HOODS ARE SHIPPED INSIDE OF UNIT. HEAT RECLAIM COIL DIMENSIONS (MAXIMUM):
- LENGTH (HEADER INCLUDED): 121"
- HEIGHT: 74.50"
- WEIGHT: 67.50"
8. HEAT RECLAIM COIL FIELD SUPPLIED OR FACTORY INSTALLED.
9. PIPE CHASE LOCATIONS ARE RECOMMENDATIONS ONLY. OPERATIONAL FACTORY SUPPLIED HOT WATER AND STEAM COILS ON UNITS WITHOUT ELECTRIC HEAT.
10. HOT WATER COIL DIMENSIONS:
- LEGS: 08'-17.25" ROWS 2
- PIPE SIZE: 1 1/2" NPT
STEAM COIL DIMENSIONS:
- LENGTH: 110.00" WIDTH: 5.00" HEIGHT: 66.00"
- PIPE SIZE: 2 1/2" NPT ROWS 2
11. ON UNITS EQUIPPED WITH FACTORY SUPPLIED POST FILTER OPTION, THE POST FILTERS ARE SHIPPED IN A SEPARATE CARTON. AS POSSIBLE, ADJACENT TO THE DISCHARGE PLENUM. THERE IS NO AVAILABLE SPACE BETWEEN THE POST FILTERS AND THE DISCHARGE OPENING.

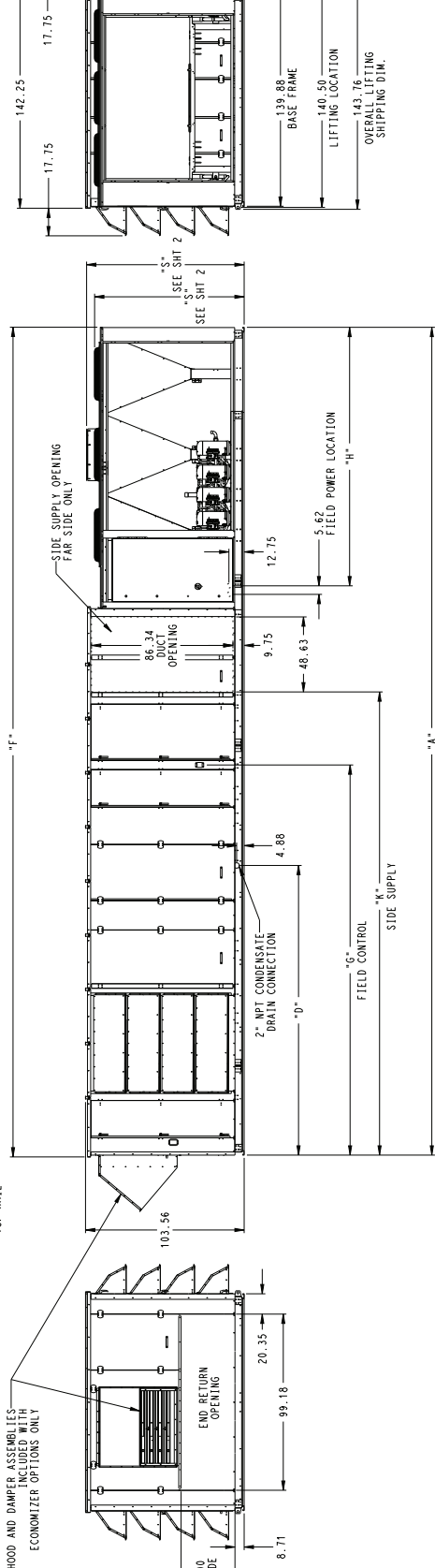
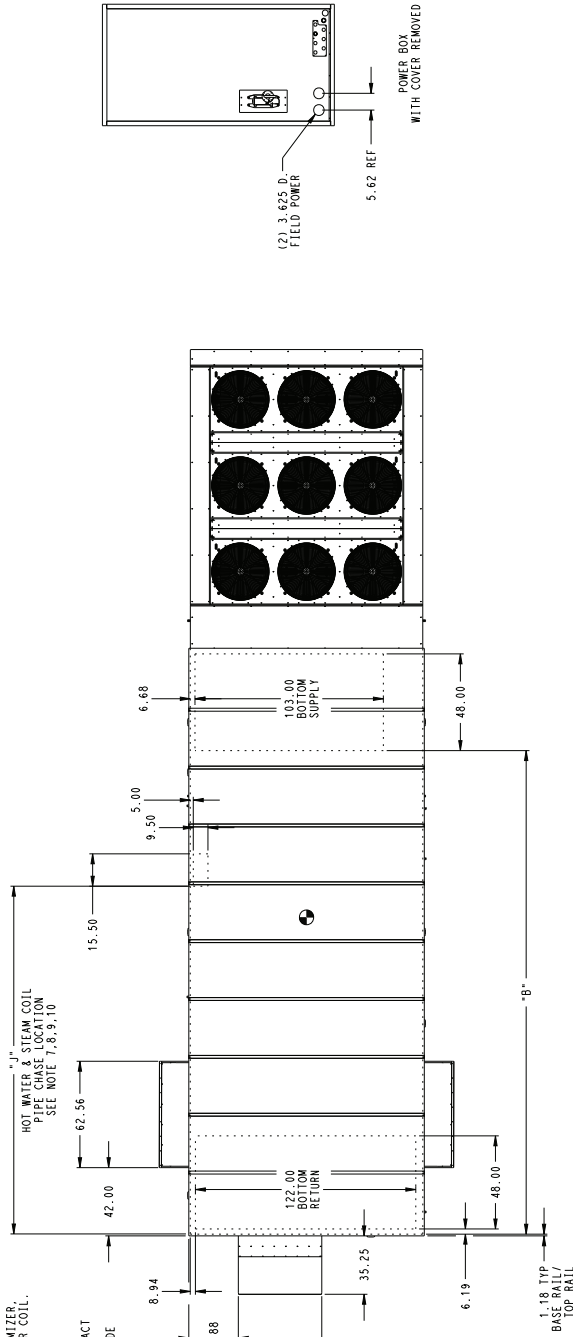

NOTE: Dimensions are in inches.

Base unit dimensions (cont)



50N UNIT SIZES R, S, T (120-150 TON NOMINAL CAPACITY)

NOMINAL CAPACITY/ EFFICIENCY	EXTENDED CHASSIS	FIELD USE FILTER SECTION	BLANK SECTION	2-PIECE UNIT	COND	A	B	D	F	G	H	J	K
120 STD EFF	NO	NO	NO	NO	2	458.04	274.35	186.86	459.28	227.68	119.76	—	273.29
			4 FT	YES	2	581.29	397.60	205.11	582.53	245.93	119.76	—	396.54
			8 FT	YES	2	629.54	445.85	205.11	630.78	245.93	119.76	—	444.79
		YES	NO	NO	2	518.54	334.85	247.36	519.78	288.18	119.76	—	333.79
			4 FT	YES	2	641.79	458.10	265.61	643.03	306.43	119.76	—	457.04
			8 FT	YES	2	690.04	506.35	265.61	691.28	306.43	119.76	—	505.29
	YES	NO	NO	NO	2	482.04	298.35	186.86	483.28	251.68	119.76	195.56	297.29
			4 FT	YES	2	605.29	421.60	205.11	606.53	269.93	119.76	213.81	420.54
			8 FT	YES	2	653.54	469.85	205.11	654.78	269.93	119.76	213.81	468.79
		YES	NO	NO	2	542.54	358.85	247.36	543.78	312.18	119.76	256.06	357.79
			4 FT	YES	2	665.79	482.10	265.61	667.03	330.43	119.76	274.31	481.04
			8 FT	YES	2	714.04	530.35	265.61	715.28	330.43	119.76	274.31	529.29
120 HI EFF 130 ALL 150 STD EFF	NO	NO	NO	NO	3	510.04	274.35	186.86	511.28	227.68	171.76	—	273.29
			4 FT	YES	3	633.29	397.60	205.11	634.53	245.93	171.76	—	396.54
			8 FT	YES	3	681.54	445.85	205.11	682.78	245.93	171.76	—	444.79
		YES	NO	NO	3	570.54	334.85	247.36	571.78	288.18	171.76	—	333.79
			4 FT	YES	3	693.79	458.10	265.61	695.03	306.43	171.76	—	457.04
			8 FT	YES	3	742.04	506.35	265.61	743.28	306.43	171.76	—	505.29
	YES	NO	NO	NO	3	534.04	298.35	186.86	535.28	251.68	171.76	195.56	297.29
			4 FT	YES	3	657.29	421.60	205.11	658.53	269.93	171.76	213.81	420.54
			8 FT	YES	3	705.54	469.85	205.11	706.78	269.93	171.76	213.81	468.79
		YES	NO	NO	3	594.54	358.85	247.36	595.78	312.18	171.76	256.06	357.79
			4 FT	YES	3	717.79	482.10	265.61	719.03	330.43	171.76	274.31	481.04
			8 FT	YES	3	766.04	530.35	265.61	767.28	330.43	171.76	274.31	529.29

50N CONDENSER DETAIL SIZES R, S, T (120-150 TON NOMINAL CAPACITY)

NOMINAL CAPACITY/EFFICIENCY	COND COILS 2V	COND COIL 3V	LOW SOUND	DIMENSION "S"
120 STANDARD EFFICIENCY	YES	—	NO	96.62
120 HIGH EFFICIENCY	—	YES	YES	102.06
120 STANDARD EFFICIENCY	YES	—	YES	102.06
130 STANDARD EFFICIENCY	—	YES	NO	96.62
130 HIGH EFFICIENCY	—	YES	YES	102.06
130 STANDARD EFFICIENCY	—	YES	YES	102.06
150 STANDARD EFFICIENCY	—	YES	YES	102.06

48/50N 075-150 STANDARD UNIT ROOF CURB

- NOTES:
1. ROOF CURB ACCESSORY CRRFCURB201A00-285A00 ARE SHIPPED DISASSEMBLED.
 2. ROOF CURB: 14 GA. (VA03-56) STL.
 3. DIMENSIONS IN [] ARE MILLIMETERS.
 4. CROSS SUPPORTS EQUALLY SPACED APPROX 5'-6" APART

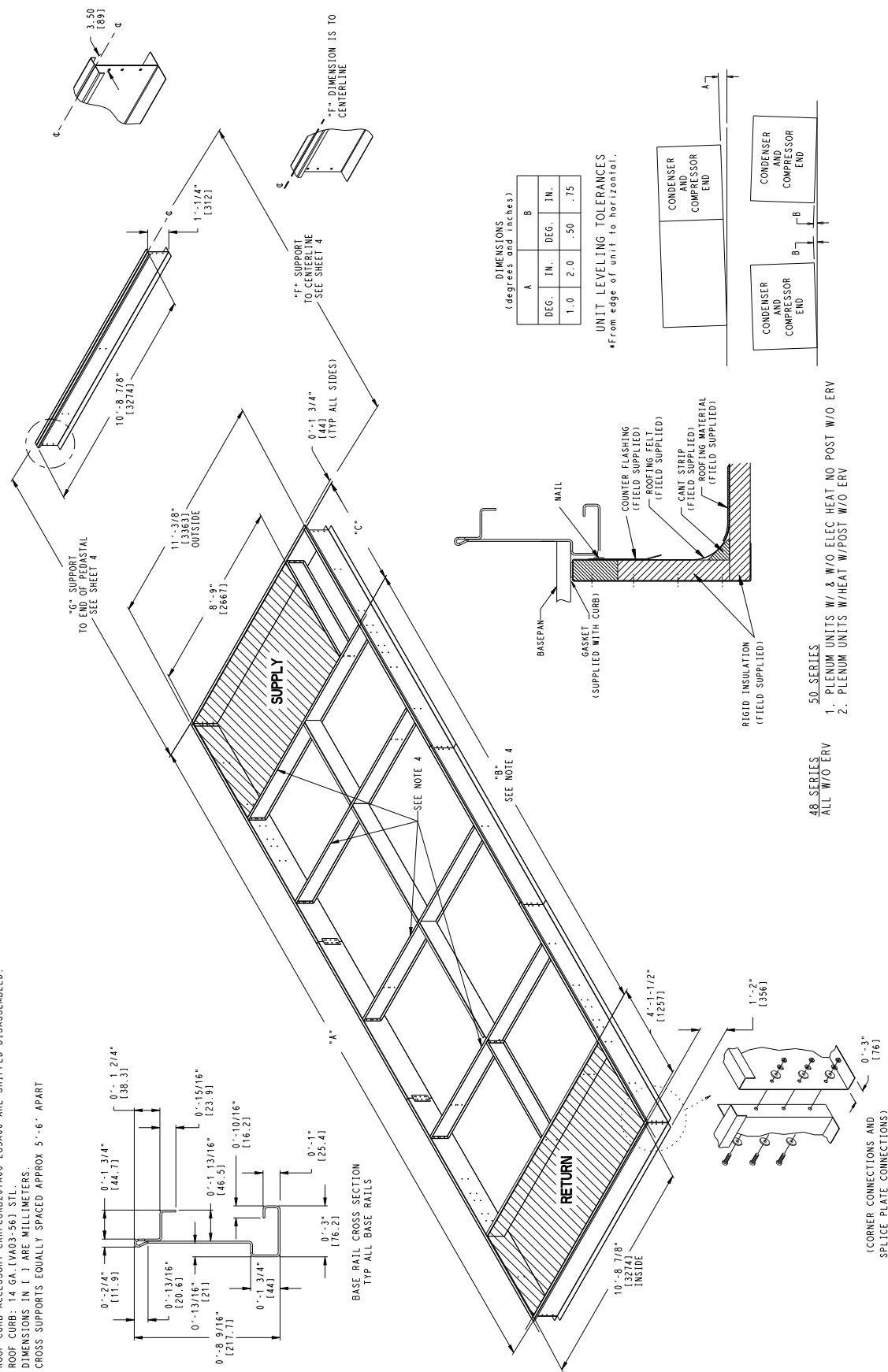

Accessory dimensions (cont)



48/50N STANDARD UNIT ROOF CURB SIZES N, P, Q (75-105 TON NOMINAL CAPACITY)

PART NUMBER*	DIMENSION A	DIMENSION B	DIMENSION C
CRRFCURB225A00	361.11	258.61	49.50
CRRFCURB226A00	376.20	273.70	49.50
CRRFCURB227A00	385.11	282.61	49.50
CRRFCURB228A00	400.20	297.70	49.50
CRRFCURB229A00	427.61	325.11	49.50
CRRFCURB230A00	439.86	337.36	49.50
CRRFCURB231A00	442.70	340.20	49.50
CRRFCURB232A00	451.61	349.11	49.50
CRRFCURB233A00	454.95	352.45	49.50
CRRFCURB234A00	463.86	361.36	49.50
CRRFCURB235A00	466.70	364.20	49.50
CRRFCURB236A00	475.86	373.36	49.50
CRRFCURB237A00	478.95	376.45	49.50
CRRFCURB238A00	488.11	385.61	49.50
CRRFCURB239A00	490.95	388.45	49.50
CRRFCURB240A00	499.86	397.36	49.50
CRRFCURB241A00	503.20	400.70	49.50
CRRFCURB242A00	512.11	409.61	49.50
CRRFCURB243A00	514.95	412.45	49.50
CRRFCURB244A00	527.20	424.70	49.50
CRRFCURB245A00	536.36	433.86	49.50
CRRFCURB246A00	551.45	448.95	49.50
CRRFCURB247A00	560.36	457.86	49.50
CRRFCURB248A00	575.45	472.95	49.50

*Use Applied Rooftop Builder program to select the proper roof curb.

NOTE: Dimensions are in inches.

48/50N STANDARD UNIT ROOF CURB SIZES R, S, T (120-150 TON NOMINAL CAPACITY)

PART NUMBER*	DIMENSION A	DIMENSION B	DIMENSION C
CRRFCURB261A00	386.04	283.54	49.50
CRRFCURB262A00	398.04	283.54	61.50
CRRFCURB263A00	410.04	307.54	49.50
CRRFCURB264A00	422.04	307.54	61.50
CRRFCURB265A00	440.29	325.79	61.50
CRRFCURB266A00	452.54	350.04	49.50
CRRFCURB267A00	464.54	350.04	61.50
CRRFCURB268A00	464.79	362.29	49.50
CRRFCURB269A00	476.54	374.04	49.50
CRRFCURB270A00	476.79	362.29	61.50
CRRFCURB271A00	488.54	374.04	61.50
CRRFCURB272A00	488.79	386.29	49.50
CRRFCURB273A00	500.79	398.29	49.50
CRRFCURB274A00	500.79	386.29	61.50
CRRFCURB275A00	512.79	398.29	61.50
CRRFCURB276A00	513.04	410.54	49.50
CRRFCURB277A00	524.79	422.29	49.50
CRRFCURB278A00	525.04	410.54	61.50
CRRFCURB279A00	536.79	422.29	61.50
CRRFCURB280A00	537.04	434.54	49.50
CRRFCURB281A00	549.04	434.54	61.50
CRRFCURB282A00	561.29	458.79	49.50
CRRFCURB283A00	573.29	458.79	61.50
CRRFCURB284A00	585.29	482.79	49.50
CRRFCURB285A00	597.29	482.79	61.50

ROOF CURB CONDENSER SUPPORT

UNIT SIZE NOMINAL TONS	COND COILS 2V	COND COIL 3V	DIM. F	DIM. G
75 ALL	YES	—	131.75±0.75	133.50
90 STD EFFICIENCY	YES	—	131.75±0.75	133.50
90 HIGH EFFICIENCY	—	YES	183.75±0.75	183.25
105 STD EFFICIENCY	YES	—	131.75±0.75	133.50
105 HIGH EFFICIENCY	—	YES	183.75±0.75	183.25
120 STD EFFICIENCY	YES	—	131.75±0.75	133.50
120 HIGH EFFICIENCY	—	YES	183.75±0.75	183.25
130 ALL	—	YES	183.75±0.75	183.25
150 ALL	—	YES	183.75±0.75	183.25

48/50N 075-150 FULL PERIMETER ROOF CURB CONDENSER SECTION

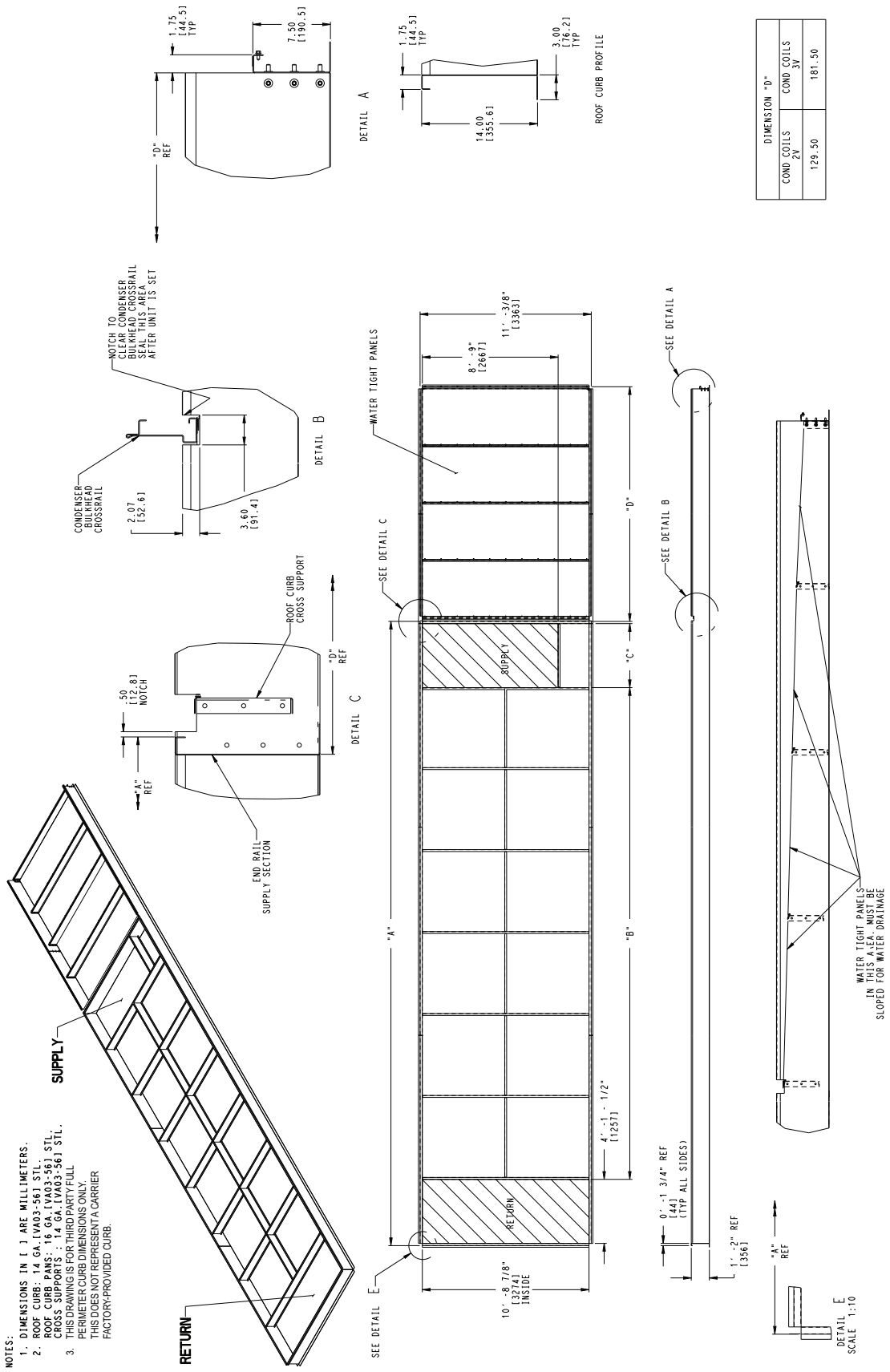

- NOTES:
1. DIMENSIONS IN [] ARE MILLIMETERS.
 2. ROOF CURB: 14 GA. (1.403-561) STL. CROSS SUPPORTS: 14 GA. (1.403-561) STL.
 3. THIS DRAWING IS FOR THIRD PARTY FULL PERIMETER CURB DIMENSIONS ONLY. THIS DOES NOT REPRESENT A CARRIER FACTORY-PROVIDED CURB.

DIMENSION "D"	
COND COILS 2V	129.50
COND COILS 3V	181.50

SCALE 1:10

48N ROOF CURB SIZES N, P, Q (75-105 TON NOMINAL CAPACITY)

PART NUMBER*	DIMENSION A	DIMENSION B	DIMENSION C
CRRFCURB225A00	361.11	258.61	49.50
CRRFCURB226A00	376.20	273.70	49.50
CRRFCURB227A00	385.11	282.61	49.50
CRRFCURB228A00	400.20	297.70	49.50
CRRFCURB229A00	427.61	325.11	49.50
CRRFCURB230A00	439.86	337.36	49.50
CRRFCURB231A00	442.70	340.20	49.50
CRRFCURB232A00	451.61	349.11	49.50
CRRFCURB233A00	454.95	352.45	49.50
CRRFCURB234A00	463.86	361.36	49.50
CRRFCURB235A00	466.70	364.20	49.50
CRRFCURB236A00	475.86	373.36	49.50
CRRFCURB237A00	478.95	376.45	49.50
CRRFCURB238A00	488.11	385.61	49.50
CRRFCURB239A00	490.95	388.45	49.50
CRRFCURB240A00	499.86	397.36	49.50
CRRFCURB241A00	503.20	400.70	49.50
CRRFCURB242A00	512.11	409.61	49.50
CRRFCURB243A00	514.95	412.45	49.50
CRRFCURB244A00	527.20	424.70	49.50
CRRFCURB245A00	536.36	433.86	49.50
CRRFCURB246A00	551.45	448.95	49.50
CRRFCURB247A00	560.36	457.86	49.50
CRRFCURB248A00	575.45	472.95	49.50

48N ROOF CURB SIZES R, S, T (120-150 TON NOMINAL CAPACITY)

PART NUMBER*	DIMENSION A	DIMENSION B	DIMENSION C
CRRFCURB261A00	386.04	283.54	49.50
CRRFCURB262A00	398.04	283.54	61.50
CRRFCURB263A00	410.04	307.54	49.50
CRRFCURB264A00	422.04	307.54	61.50
CRRFCURB265A00	440.29	325.79	61.50
CRRFCURB266A00	452.54	350.04	49.50
CRRFCURB267A00	464.54	350.04	61.50
CRRFCURB268A00	464.79	362.29	49.50
CRRFCURB269A00	476.54	374.04	49.50
CRRFCURB270A00	476.79	362.29	61.50
CRRFCURB271A00	488.54	374.04	61.50
CRRFCURB272A00	488.79	386.29	49.50
CRRFCURB273A00	500.79	398.29	49.50
CRRFCURB274A00	500.79	386.29	61.50
CRRFCURB275A00	512.79	398.29	61.50
CRRFCURB276A00	513.04	410.54	49.50
CRRFCURB277A00	524.79	422.29	49.50
CRRFCURB278A00	525.04	410.54	61.50
CRRFCURB279A00	536.79	422.29	61.50
CRRFCURB280A00	537.04	434.54	49.50
CRRFCURB281A00	549.04	434.54	61.50
CRRFCURB282A00	561.29	458.79	49.50
CRRFCURB283A00	573.29	458.79	61.50
CRRFCURB284A00	585.29	482.79	49.50
CRRFCURB285A00	597.29	482.79	61.50

50N ROOF CURB SIZES N, P, Q (75-105 TON NOMINAL CAPACITY)

PART NUMBER*	DIMENSION A	DIMENSION B	DIMENSION C
CRRFCURB201A00	296.11	193.61	49.50
CRRFCURB202A00	311.20	208.70	49.50
CRRFCURB203A00	320.11	217.61	49.50
CRRFCURB204A00	335.20	232.70	49.50
CRRFCURB205A00	356.61	254.11	49.50
CRRFCURB206A00	371.70	269.20	49.50
CRRFCURB207A00	380.61	278.11	49.50
CRRFCURB208A00	395.70	293.20	49.50
CRRFCURB209A00	419.36	316.86	49.50
CRRFCURB210A00	434.45	331.95	49.50
CRRFCURB211A00	443.36	340.86	49.50
CRRFCURB212A00	485.45	382.95	49.50
CRRFCURB213A00	467.61	365.11	49.50
CRRFCURB214A00	479.86	377.36	49.50
CRRFCURB215A00	482.70	380.20	49.50
CRRFCURB216A00	491.61	389.11	49.50
CRRFCURB217A00	494.95	392.45	49.50
CRRFCURB218A00	503.86	401.36	49.50
CRRFCURB219A00	506.70	404.20	49.50
CRRFCURB220A00	518.95	416.45	49.50
CRRFCURB221A00	528.11	425.61	49.50
CRRFCURB222A00	543.20	440.70	49.50
CRRFCURB223A00	552.11	449.61	49.50
CRRFCURB224A00	567.20	464.70	49.50

50N ROOF CURB SIZES R, S, T (120-150 TON NOMINAL CAPACITY)

PART NUMBER*	DIMENSION A	DIMENSION B	DIMENSION C
CRRFCURB249A00	321.04	218.54	49.50
CRRFCURB250A00	345.04	242.54	49.50
CRRFCURB251A00	381.54	279.04	49.50
CRRFCURB252A00	405.54	303.04	49.50
CRRFCURB253A00	444.29	341.79	49.50
CRRFCURB254A00	468.29	365.79	49.50
CRRFCURB255A00	492.54	390.04	49.50
CRRFCURB256A00	504.79	402.29	49.50
CRRFCURB257A00	516.54	414.04	49.50
CRRFCURB258A00	528.79	426.29	49.50
CRRFCURB259A00	553.04	450.54	49.50
CRRFCURB260A00	577.04	474.54	49.50

*Use Applied Rooftop Builder program to select the proper roof curb.
NOTE: Dimensions are in inches.

COMPONENT PRESSURE DROPS (in. wg) SIZES N, P, Q (75-105 TON NOMINAL CAPACITY)

COMPONENT	AIRFLOW (cfm)									
	15,000	19,000	23,000	27,000	31,000	35,000	39,000	43,000	47,000	52,000
High-Capacity Coil (75-90)	0.05	0.10	0.14	0.18	0.22	0.26	0.29	0.32	0.34	0.37
High-Capacity Coil (105)	0.04	0.09	0.14	0.19	0.24	0.28	0.32	0.36	0.40	0.44
Humidi-MiZer® System (75-105)	0.02	0.03	0.05	0.09	0.17	0.25	0.39	0.54	0.70	0.91
Hydronic Coil (75-105)	0.13	0.20	0.28	0.37	0.46	0.57	0.68	0.80	0.93	1.10
Steam Coil (75-105)	0.14	0.22	0.31	0.41	0.51	0.63	0.75	0.88	1.02	1.21
Low Gas Heat (75-105)	0.15	0.20	0.26	0.33	0.41	0.49	0.58	0.68	0.78	0.92
Medium Gas Heat (75-105)	0.18	0.25	0.33	0.42	0.51	0.62	0.73	0.85	0.98	1.15
High Gas Heat (75-105)	0.26	0.35	0.45	0.56	0.67	0.80	0.94	1.09	1.24	1.45
Electric Heat (108 kW)	0.05	0.08	0.12	0.16	0.21	0.27	0.34	0.42	0.50	0.62
Electric Heat (108 kW, High Fan)	0.08	0.12	0.17	0.24	0.32	0.41	0.51	0.63	0.75	0.93
Electric Heat (144 kW)	0.06	0.09	0.13	0.18	0.23	0.30	0.38	0.46	0.55	0.68
Electric Heat (144 kW, High Fan)	0.08	0.13	0.19	0.27	0.35	0.45	0.56	0.69	0.83	1.02
Electric Heat (190 kW)	0.06	0.10	0.14	0.19	0.26	0.33	0.41	0.51	0.61	0.75
Electric Heat (190 kW, High Fan)	0.09	0.14	0.21	0.29	0.39	0.50	0.62	0.76	0.91	1.12
Electric Heat (265 kW)	0.07	0.11	0.15	0.21	0.28	0.36	0.46	0.56	0.67	0.82
Electric Heat (265 kW, High Fan)	0.10	0.16	0.23	0.32	0.43	0.55	0.68	0.84	1.00	1.24
FILTERS										
Mixed Air Filters										
4 in. MERV 8 Mix	0.00	0.00	0.00	0.00	0.00	0.00	0.00	0.00	0.00	0.00
4 in. MERV 14 Mix	0.12	0.16	0.20	0.24	0.27	0.29	0.31	0.33	0.35	0.36
Cartridge Filter Mixed 2 in. Pre-Filter	0.28	0.37	0.45	0.52	0.60	0.67	0.73	0.79	—	—
Cartridge Filter Mixed 4 in. Pre-Filter	0.21	0.27	0.33	0.39	0.44	0.49	0.54	0.58	—	—
MERV 14 Bag 2 in. Pre-Filter	0.21	0.27	0.33	0.39	0.44	0.49	0.54	0.58	—	—
MERV 14 Bag 4 in. Pre-Filter	0.13	0.18	0.22	0.25	0.29	0.32	0.34	0.36	—	—
MERV 15 Bag 2 in. Pre-Filter	0.21	0.27	0.33	0.39	0.44	0.49	0.54	0.58	—	—
MERV 15 Bag 4 in. Pre-Filter	0.13	0.18	0.22	0.25	0.29	0.32	0.34	0.36	—	—
Final Filters										
Cartridge Filter Final 2 in. Pre-Filter	0.30	0.39	0.48	0.56	0.64	0.71	0.78	—	—	—
Cartridge Filter Final 4 in. Pre-Filter	0.22	0.29	0.36	0.42	0.48	0.53	0.58	—	—	—
MERV 15 Bag Final 2 in. Pre-Filter	0.22	0.29	0.36	0.42	0.48	0.53	0.58	—	—	—
MERV 15 Bag Final 4 in. Pre-Filter	0.14	0.19	0.24	0.28	0.31	0.34	0.37	—	—	—
HEPA Final 2 in. Pre-Filter	0.38	0.49	0.60	0.70	0.80	0.90	0.99	—	—	—
HEPA Final 4 in. Pre-Filter	0.30	0.39	0.48	0.56	0.64	0.71	0.78	—	—	—
Economizer Pressure Drop	0.07	0.09	0.11	0.15	0.19	0.24	0.29	0.35	0.41	0.50
High PE (Power Exhaust) Fan (off)	0.02	0.05	0.09	0.12	0.15	0.19	0.24	0.30	0.35	0.44
Low PE Fan (90-105) (off)	0.00	0.05	0.10	0.13	0.17	0.21	0.25	0.30	0.35	0.44
Low PE Fan (75) (off)	0.06	0.08	0.10	0.13	0.15	0.20	0.25	0.29	0.36	0.43
Outdoor Airflow Station	0.00	0.03	0.07	0.09	0.11	0.14	0.17	0.20	0.23	0.28

COMPONENT PRESSURE DROPS (in. wg) SIZES R, S, T (120-150 TON NOMINAL CAPACITY)

COMPONENT	AIRFLOW (cfm)									
	24,000	28,000	32,000	36,000	40,000	44,000	48,000	52,000	56,000	60,000
High-Capacity Coil (120)	0.10	0.13	0.16	0.19	0.22	0.25	0.28	0.31	0.33	0.36
High-Capacity Coil (130-150)	0.11	0.14	0.17	0.20	0.23	0.26	0.29	0.33	0.36	0.39
Humidi-MiZer® System (120-150)	0.06	0.11	0.19	0.29	0.42	0.56	0.73	0.92	1.14	1.38
Hydronic Coil (120-150)	0.18	0.23	0.28	0.34	0.41	0.48	0.55	0.63	0.71	0.80
Steam Coil (120-150)	0.21	0.27	0.34	0.41	0.49	0.57	0.66	0.76	0.86	0.96
Low Gas Heat (120-150)	0.28	0.35	0.43	0.51	0.61	0.71	0.81	0.93	1.04	1.17
Medium Gas Heat (120-150)	0.35	0.44	0.54	0.64	0.76	0.88	1.02	1.16	1.31	1.46
High Gas Heat (120-150)	0.47	0.58	0.70	0.83	0.97	1.11	1.26	1.42	1.59	1.76
Electric Heat (144 kW)	0.13	0.18	0.24	0.30	0.38	0.46	0.55	0.65	0.76	0.87
Electric Heat (144 kW, High Fan)	0.20	0.27	0.36	0.46	0.57	0.69	0.83	0.98	1.14	1.31
Electric Heat (265 kW)	0.15	0.20	0.26	0.34	0.42	0.51	0.61	0.72	0.83	0.96
Electric Heat (300 kW)	0.22	0.30	0.39	0.50	0.62	0.76	0.91	1.07	1.25	1.44
Electric Heat (300 kW, High Fan)	0.29	0.39	0.51	0.65	0.81	0.99	1.18	1.39	1.63	1.87
FILTERS										
Mixed Air Filters										
4 in. MERV 8 Mix	0.00	0.00	0.00	0.00	0.00	0.00	0.00	0.00	0.00	0.00
4 in. MERV 14 Mix	0.21	0.24	0.27	0.30	0.32	0.34	0.35	0.36	0.36	0.36
Cartridge Filter Mixed 2 in. Pre-Filter	0.47	0.54	0.62	0.68	0.75	0.81	0.86	—	—	—
Cartridge Filter Mixed 4 in. Pre-Filter	0.35	0.40	0.46	0.50	0.55	0.59	0.62	—	—	—
MERV 14 Bag 2 in. Pre-Filter	0.35	0.40	0.46	0.50	0.55	0.59	0.62	—	—	—
MERV 14 Bag 4 in. Pre-Filter	0.23	0.26	0.30	0.32	0.35	0.37	0.38	—	—	—
MERV 15 Bag 2 in. Pre-Filter	0.35	0.40	0.46	0.50	0.55	0.59	0.62	—	—	—
MERV 15 Bag 4 in. Pre-Filter	0.23	0.26	0.30	0.32	0.35	0.37	0.38	—	—	—
Final Filters										
Cartridge Filter Final 2 in. Pre-Filter	0.50	0.59	0.66	0.73	0.80	0.87	0.93	—	—	—
Cartridge Filter Final 4 in. Pre-Filter	0.37	0.43	0.49	0.54	0.59	0.63	0.67	—	—	—
MERV 15 Bag Final 2 in. Pre-Filter	0.37	0.43	0.49	0.54	0.59	0.63	0.67	—	—	—
MERV 15 Bag Final 4 in. Pre-Filter	0.25	0.29	0.32	0.35	0.38	0.40	0.42	—	—	—
HEPA Final 2 in. Pre-Filter	0.62	0.73	0.83	0.92	1.01	1.10	1.18	—	—	—
HEPA Final 4 in. Pre-Filter	0.50	0.58	0.66	0.73	0.80	0.87	0.93	—	—	—
Economizer Pressure Drop	0.11	0.16	0.18	0.24	0.30	0.40	0.44	0.51	0.68	0.67
High PE Fan (off)	0.08	0.11	0.14	0.19	0.24	0.26	0.28	0.33	0.40	0.42
Low PE Fan (off)	0.10	0.15	0.17	0.23	0.28	0.33	0.37	0.44	0.48	0.58
Outdoor Airflow Station	0.08	0.11	0.13	0.16	0.20	0.24	0.28	0.33	0.38	0.43

Please refer to the Applied RTUBuilder software for the unit electrical data.

SUPPLY/EXHAUST/RETURN FAN MOTOR LIMITATIONS

NOMINAL HP	BkW	MAX BHP	MAX BkW	MAX AMPS (EA)		RATED EFFICIENCY
				460 V	575 V	
7.5	5.60	8.6	6.39	12.0	10.0	91.7
10	7.46	11.5	8.56	14.3	12.0	91.7
15	11.19	17.3	12.89	22.0	19.0	93.0
20	14.92	22.9	17.10	28.7	23.0	93.6
25	18.65	28.7	21.41	36.3	28.4	93.6
30	22.38	34.5	25.71	41.7	36.3	94.1
40	29.84	45.9	34.27	55.0	43.8	94.1
50	37.30	57.4	42.83	71.0	52.8	94.5
60	44.80	68.9	51.41	83.0	60.5	95.0
75	59.50	86.1	64.25	101.0	80.5	95.0
100	74.60	114.8	85.67	132.0	106.0	95.4

LEGEND

Bhp — Brake Horsepower
BkW — Brake Kilowatts

NOTES:

1. Extensive motor and electrical testing on the Carrier units has ensured that the full horsepower range of the motor can be utilized with confidence. Using fan motors up to the horsepower ratings shown in the Motor Limitations table will not result in nuisance tripping or premature motor failure. Unit warranty will not be affected.
2. All motors comply with the Energy Independence Security Act (EISA) of 2007.

Control components

The 48/50N Series rooftops use the *ComfortLink* control system that has been developed for use in Carrier Commercial equipment. The control system monitors all operating conditions in the rooftop unit as well as controlling the compressors, economizers, fans, heat, and other devices. It also has the capability of communicating with the Carrier Comfort Network® devices using the CCN protocol, Carrier i-Vu Open, and other popular protocols including BACnet, Modbus, and LonWorks.

The system uses a microprocessor and a series of boards, each with inputs and outputs. A local network communications bus (LEN) ties all the boards together into a system and enables the boards to communicate.

For the 48/50N Series, the control consists of the following key components.

Main base board (MBB)

The MBB is the center of the *ComfortLink* control system. It contains the major portion of the operating software and controls the operation of the unit. The MBB continuously monitors inputs and controls outputs, as well as sends and receives data over the LEN and CCN communications channels. The board is located in the control box.

Rooftop control board (RXB)

The RXB controls many unit functions. The RXB controls the actuators for the economizer, hydronic heating valve, and humidifier valve using a digital communications signal. This signal also provides operation and diagnostic data on the actuators. The RXB also has relay outputs to control condenser fans, minimum load valve, and the heat interlock output. The RXB board is located in the control box.

Compressor expansion board (CXB)

The CXB provides additional compressor control outputs and is located in the control box.

Options control board (EXB)

The EXB is used on units with the optional return fan, digital scroll compressors, low ambient option, airflow sensor option, or VFD with bypass option, or when control of a humidifier is required. This board is located in the control box.

Expansion valve board (EXV)

Two EXV boards control the electronic expansion valves in the system. These boards also accept an optional liquid line temperature for prognostics and a status input when the VFD bypass option is installed. If the unit is equipped with the optional Humidi-MiZer® system, a third EXV board controls the bypass and condenser modulating valves. The EXV boards are located in the control box.

Staged gas heat board (SCB)

The SCB board will be installed when modulating gas heat or SCR electric heat options are installed. On units with modulating gas heat, the SCB stages the operation of the gas valves and provides an analog signal to modulate the gas valve. On units with SCR electric heat, the SCB will control the operation of the SCRs. The SCB is also installed when the Prognostics or Heat Reclaim options are used. It also provides additional sensors for monitoring of the supply-air temperature. This board is located in the control box.

Modulating gas heat boards

When the optional modulating gas heat is used, one timer relay board (TR1) and one signal conditioner board (SC30) will be installed in the heating compartment. The two boards in combination with SCB board provide control to the modulating gas heat section. Refer to the Unit Controls and Troubleshooting book for information on modulating gas control.

Integrated gas controller (IGC)

One IGC is provided with each bank of gas heat exchangers. It controls the direct spark ignition system and monitors the rollout switch, limit switches, and induced-draft motor Hall Effect sensor. For units equipped with modulating gas heat, the induced-draft motor function is proven with a pressure switch. The IGC is equipped with an LED for diagnostics. The IGCs are located in the gas heat section.

Controls expansion module (CEM)

The optional expansion module is used to provide inputs for supply air set point reset, static pressure reset, demand limiting, humidity control, outdoor air quality, and other optional inputs. It is located in the control box.

Compressor protection Cycle-LOC™ board (CSB)

This board monitors the status of the compressor by sensing the current flow to the compressors and then provides digital status signal to the MBB. The CSBs are located in the power box.

Navigator™ display

This device is the keypad interface used to access the control information, read sensor values, test the unit, and monitor alarm status. The Navigator has a 4 line x 20 character backlit LCD display. The display is very easy to operate using 4 buttons and a group of 11 LEDs that indicate the following menu:

- Run Status
- Outputs
- Service Test
- Configuration
- Temperatures
- Timeclock
- Pressures
- Operating Modes
- Set Points
- Alarms
- Inputs

Through the display, inputs and outputs can be checked for their value or status. Because the unit is equipped with suction pressure transducers and discharge saturation temperature sensors, it can also display pressures typically obtained from gages. The control includes a full alarm history which can be accessed from the display. Through the display, a built-in test routine can be used at start-up commission and during maintenance inspections to help diagnose operational problems with the unit.

BACnet communication option

The BACnet communication option includes a factory installed UPC Open BACnet communication board that allows *ComfortLink* to connect to a BACnet MS/TP network. See the Controls, Start-Up, Operation, Service and Troubleshooting manual for configuration details and BACnet points list.

The UPC Open BACnet communication option also allows the rooftop unit to integrate seamlessly into a Carrier i-Vu Open building automation system. The plug and play connectivity supports functionality such as integrated graphics, access to points and properties, diagnostic trends and alarms, and airside linkage functionality.

The UPC Open features an Rnet port and local access port. The local access port can be used for field assistant or Equipment Touch app (with USB Link cable) connectivity. The Rnet port can be used for Carrier ZS communicating sensors or Carrier Equipment Touch touchscreen interface.

Cooling control options

When mechanical cooling is required, the N Series *ComfortLink* controls have the capability to control the staging of the compressors in several different ways. Five scroll compressors are used on 75 ton units, six scroll compressors on 90 and 105 ton units, and eight scroll compressors on 120 to 150 ton units. In addition, a digital unloading type scroll compressor is available as an option on all units.

The *ComfortLink* controls also support the use of an optional minimum load hot gas bypass valve (MLV) with the Multiple Adaptive Demand and VAV control sequences. The MLV is directly controlled by the *ComfortLink* controls and provides an additional stage of capacity as well as low load coil freeze protection. The control also integrates the use of an economizer with the use of mechanical cooling to allow for the greatest use of free cooling.

When both mechanical cooling and the economizer are being used, the control will use the economizer to provide better temperature control and limit the cycling of the compressors. The control also checks on various other operation parameters in the units to make sure that safety limits are not exceeded and the compressors are reliably operated.

The N Series *ComfortLink* controls offer three control approaches to mechanical cooling: constant volume, SAV™, and VAV, all with multiple stages of cooling.

Control type

The control type determines the selection of the type of cooling control as well as the technique for selecting a cooling mode. The control types are:

VAV-RAT and VAV-SPT — Both of these configurations refer to standard VAV operation. If the control is in the occupied mode, the supply fan is run continuously and return-air temperature will be used in the determination of the selection of the cooling mode. The difference between VAV-SPT and VAV-RAT is during the unoccupied period. In VAV-SPT space temperature will be used versus return-air temperature in VAV-RAT to start the supply fan for ten minutes before the return-air temperature is allowed to call out any operating mode.

CV or SAV TSTAT-Multiple Stage — This configuration will force the control to monitor the thermostat inputs (Y1,Y2) to make a determination of mode. Unlike traditional 2-stage thermostat control, the unit is allowed to use multiple stages of cooling control and perform VAV-style capacity control. Also referred to as Multiple Adaptive Demand.

CV or SAV SPT-Multiple Stage — This configuration will force the control to monitor a space temperature sensor to make a determination of mode. The unit is allowed to use multiple stages of cooling control and perform VAV-style capacity control. Also referred to as Multiple Adaptive Demand.

Cooling control method

Two different cooling control methods are used to step through the available stages of capacity. Depending on the unit size, cooling control method, and presence of an MLV, this may range from 5 up to 9 stages of capacity control.

These methods are:

Multiple Stage Evaporator Discharge Temperature (EDT)

The capacity of the economizer and compressors is controlled based on the evaporator air discharge temperature and supply air temperature set point. This control method uses an adaptive PID (proportional, integral, derivative) algorithm, called SumZ, to calculate the estimated change in supply-air temperature before engaging or disengaging the next stage of cooling. The algorithm compensates for varying conditions, including changing flow rates across the evaporator coil, to provide better overall control of compressor staging.

Multiple Adaptive Demand

This control method will base the capacity of the economizer and compressors on the evaporator air discharge temperature and one of two supply air temperature set points. The control will call out a LOW COOL or a HIGH COOL mode and maintain a low or high cool supply air set point. The unit will use either the input from a conventional thermostat to turn the Y1, Y2 signals into a high and low demand signal, or with a space temperature sensor use a differential from set point to determine the mode. Once the mode has been established the control uses the same algorithm as with VAV control.

Integrated economizer

For each of the above modes of operation all mechanical cooling will first be delayed while the unit attempts to use the economizer for free cooling. Once the economizer is at full capacity, the controls will then supplement the free cooling with as much mechanical cooling as required. To prevent any rapid changes in cooling, the controls will also use the economizer to trim the cooling supplied.

Heating control options

When heating is required, the N Series units can be provided with 2-stage electric heat, 2-stage gas heat, modulating gas heat, SCR electric heat, or modulating hydronic heat. Modulating gas heat provides variable heating loads depending on unit size and overall heating capacity. The N Series *ComfortLink* controls have the capability to control the heating capacity based on input from a 2-stage mechanical thermostat, a space temperature sensor, or, on VAV units, by the return air temperature sensor.

With CV units the heating mode (off, low, or high) will be enabled based on W1 and W2 thermostat inputs, or when using a space temperature sensor the differential from heating set point will be used. Heating with VAV units will be enabled based on the return-air temperature or the space temperature, but once enabled control will be based on the return-air temperature. Variable air volume terminals will be commanded open to the heating cfm through linkage or the heat interlock relay.

The N Series *ComfortLink* controls will use one of the following control methods:

Two-stage control (gas or electric heat)

The unit will operate in LOW HEAT or HIGH HEAT mode as determined by the demand inputs. In the LOW HEAT

mode if the temperature sensed by the evaporator discharge temperature sensor is below 50°F, the unit will automatically go into a HIGH HEAT mode.

Modulating control (gas heat only) or SCR control (electric heat only)

When the unit is in a LOW HEAT mode the algorithm calculates the desired heat capacity based on set point and supply-air temperature. Units with modulating or SCR control logic will continuously modulate the heating capacity to match the calculated demand. When the unit is in a HIGH HEAT mode all stages of heat will be activated. Both SCR and modulating gas heat options can also be used in a TEMPERING mode. This mode is enabled during a VENTILATION, LOW COOL, or HIGH COOL mode when the economizer dampers are at their minimum ventilation position and the mixed-air temperature is below the supply air set point. In tempering the mixed-air temperature is raised to the desired supply air set point. Tempering can also be used during a preoccupancy purge to prevent low temperature air from being delivered to the space.

Modulating hydronic coil control

When the unit is in a LOW HEAT mode the algorithm calculates the desired heat capacity based on set point and supply-air temperature. The valve control logic will modulate the heating capacity to match the calculated demand. When the unit is in a HIGH HEAT mode the modulating valve will go to a full open position. Modulating hydronic heat can also be used in a TEMPERING mode. This mode is enabled during a VENTILATION, LOW COOL or HIGH COOL mode when the economizer dampers are at their minimum ventilation position and the mixed-air temperature is below the supply air set point. Tempering can also be used during a preoccupancy purge to prevent low temperature air from being delivered to the space.

Economizer, building pressure control, and IAQ options

The controls have been designed to support the requirements of indoor air quality control through the use of outside air. Units can either be equipped with a motorized outside-air damper or a fully modulating economizer. The economizer can be configured for a full modulation mode or 3-position mode of operation. The control includes logic for a minimum ventilation position and different set points for occupied and unoccupied minimum position set points. This control also has logic built in to calibrate the economizer position to the actual percentage of outside air introduced (outdoor air CFM option required). During periods when the compressors are not being used the control will use the RAT, SAT, and OAT to calibrate the economizer. This will allow for setting the outside air actual percentage and not just the percent damper position. The use of the economizer will depend on the mode of change selected. This control integrates the changeover directly into the control. Five types of changeover are available:

- Outdoor air dry bulb
- Differential dry bulb
- Outdoor air enthalpy
- Differential enthalpy
- Outdoor air dew point

The units are provided with an outdoor air sensor, return air temperature sensor, and outdoor enthalpy switch so the first three changeover methods are available as standard. To use the enthalpy changeover options the control supports the addition of highly reliable, electronic humidity sensors. The

humidity sensor input is then used with the dry bulb sensors to calculate the enthalpy. For outdoor enthalpy changeover the control also has the ASHRAE 90.1 - A, B, C, D economizer changeover curves built into the software. When operating with outside air economizers, large amounts of air can be introduced into the building and a means must be provided for building pressure relief. The 48/50N Series control supports the following types of building pressure control:

- Motorized outdoor air damper — may be used when an economizer is not required.
- Modulating power exhaust — The units can be equipped with modulating power exhaust. The exhaust airflow is controlled by modulating the speed of the exhaust fan with a variable frequency drive (VFD). The *ComfortLink* controls the motor speed through the VFD to maintain the building pressure set point.
- Modulating return fan — Both the VAV and CV units can be equipped with modulating return fan. The primary function of a return fan is to handle return duct losses, allowing the supply fan to handle only internal and supply static load. Return fans should never be used on systems with less than 0.5-in. wg return static. The return fan runs whenever the supply fan is operating and its speed is controlled by a variable frequency drive. The *ComfortLink* controls measure the supply fan airflow and adjusts the return fan speed to maintain a programmed airflow differential (accomplished via factory-installed supply air and return air CFM measuring stations, which are included with return fan option). The airflow differential is dynamically adjusted to maintain building pressure set point. The units may be equipped with a variety of filter types and can have an optional filter pressure drop switch or pressure transducer to warn of dirty filter conditions.

Indoor air quality

The indoor air quality (IAQ), also referred to as Demand Controlled Ventilation (DCV), function provides a demand-based control for ventilation air quantity, by providing a modulating outside air damper position that is proportional to the space CO₂ level. The ventilation damper position is varied between a minimum ventilation level (based on internal sources of contaminants and CO₂ levels other than the effect of people) and the maximum design ventilation level (determined at maximum populated status in the building). During a less-than-fully populated space period, the CO₂ level will be lower than that at full-load design condition and will require less ventilation air. Reduced quantities of ventilation air will result in reduced operating costs. Space CO₂ levels are monitored and compared to user-configured set points. Accessory CO₂ sensor for space (or return duct mounting) is required.

Outdoor air quality

The IAQ routine can be enhanced by also installing a sensor for outdoor air quality. During the occupied period, in the absence of a demand for cooling using outside air, if CO₂ levels are below the set point for the minimum ventilation level, the outside-air damper will open to the minimum ventilation level damper position set point. The minimum damper position will be maintained as long as the CO₂ level remains below the set point.

When the space CO₂ level exceeds set point for the minimum ventilation level condition, the *ComfortLink* controls will begin to open the outside air damper position to admit

more ventilation air and remove the additional contaminants. As the space CO₂ level approaches the set point for maximum design ventilation level condition, the outside air damper position will reach the maximum ventilation level damper position set point limit. Damper position will be modulated in a directly proportional relationship between these two CO₂ set point limits and their corresponding damper position limits.

In most applications a fixed reference value can be set for the outdoor air quality level, but the control also supports the addition of an outdoor air quality sensor that will be compared to the indoor or return IAQ sensor. If an OAQ (outdoor air quality) sensor is connected, the demand set point levels will be adjusted automatically as the outdoor CO₂ levels vary. Also, if the outdoor CO₂ level exceeds a user-configured maximum limit value, then outside air damper position will be limited to the minimum ventilation damper set point value. The control can also receive these signals through the CCN system.

The IAQ and OAQ measurement levels are displayed by the *ComfortLink* scrolling marquee in parts per million (ppm).

Outdoor air cfm control

Minimum space ventilation requirements can also be maintained by applying the minimum outdoor air cfm control option. This option provides an airflow monitoring station at the outside air damper inlet. The *ComfortLink* controls can be programmed to monitor this airflow rate and to override the current outside air damper position to maintain a minimum quantity of outdoor air at the user's design set point even as the unit's supply fan slows during part load operating periods.

Fire and smoke controls interface

The unit can be equipped with an optional return air smoke detector. The smoke detector is wired to stop the unit and send a message to a remote alarm system if a fault condition is detected. If the controls expansion module (CEM) is added, the control will support smoke control modes including evacuation, smoke purge, and pressurization.

Demand limiting

The control supports demand limiting using one or two fixed capacity limits initiated by discrete input switches or a variable capacity limit function based on an analog input signal. On CCN systems this can be done through the network, or for non-CCN network jobs this can be done by adding the controls expansion module.

Diagnostics

The *ComfortLink* controls have fully integrated all controls and sensors into a common control system. The control monitors these inputs as well as many of the routines to provide advanced diagnostics and prognostics. These include adaptive logic to allow the unit to continue to operate in a reduced output mode and automatic resets where applicable. The last 10 alarms and alerts are stored in memory and can be accessed through the Navigator hand held interface. The alarms can also be monitored through the Carrier Comfort Network® connection. The hand held Navigator™ display may be plugged in at the control box and at an auxiliary connection point at the opposite end of the unit.

Some of the diagnostics that are included are:

- Monitoring of all sensors
- Suction pressure transducers to provide compressor protection and coil freeze protection

- Monitoring of the economizer motor using a digitally controlled motor
- Monitoring of compressor status using compressor protection boards
- Adaptive logic for low supply air temperatures
- Adaptive logic for extreme outdoor air temperatures
- Compressor lockout at low ambient conditions
- Storage of compressor run hours and starts
- Low refrigerant charge protection
- Compressor reverse rotation protection

Control interface

The *ComfortLink* controller can interface with an i-Vu® Open control system, a BACnet building automation system, or Carrier Comfort Network devices. This will allow for the use of all system control programs. These include:

- Network Service Tool
 - System Pilot™ device
 - Touch Pilot™ device
 - i-Vu® Open control system software
 - ComfortVIEW™ software
 - CCN Web software
 - ComfortID™ system
- Contact Carrier Controls Marketing for more information. The control can also provide interface with other energy management systems with the addition of either the Modbus Carrier translator or the LonWorks Carrier translator. Several contact connection points have been provided in the control box for interface to external controls and systems. These are summarized in the Interface Connection table in the Controls, Start-Up, Operation, Service, and Troubleshooting literature. External controls use the following interface points:
- Start/Stop (On/Off) — Start/Stop is accomplished with a contact closure between terminals 3 and 4 on TB201.
 - Remote Economizer Enable — Enabling and disabling of the economizer can be done by connecting a contact closure to terminals 5 and 6 on TB201. The economizer can be configured for a switch closure changeover for 3-position operation.
 - VAV Heating Interlock — Interface with non-linkage terminals can be done through TB201 terminals 9 and 10.
 - Remote IAQ Inputs — External IAQ demand inputs can be connected through terminals 7 and 8 on TB201.
 - Smoke Detectors Alarm Output — Remote detector alarm outputs can be connected through terminals 1 and 2 on TB201.
 - Fire Shutdown — A remote fire shutdown signal can be connected to 1 and 2 on TB201. The software can be configured to shut the unit down on an open or closed signal.
 - Fire Pressurization — For remote control of pressurization, a contact closer can be connected to terminals 18 and 19 on TB202. In this mode the economizer damper will be fully opened and the supply fan turned on to pressurize the space.
 - Fire Evacuation — For this mode a remote contact closure can be connected to terminals 16 and 17 on TB202. For remote evacuation of a space the outside-air dampers will be opened and the power exhaust fans turned on to evacuate the space of smoke.

- Fire Purge — For this mode external contacts can be connected to terminals 14 and 15 on TB202. In this mode the supply fan and return fans will be turned on with the economizer at a full open position.
- Demand Limiting — For demand limiting the controls expansion module must be used. Connections are provided on TB202 for switch input demand limiting (terminals 20 and 21, 22 and 23) and for 4 to 20 mA (terminals 10 and 11) demand limit signals.
- Dehumidification — A discrete input is available on TB202, terminals 24 and 25, to initiate the Dehumidification mode.
- Remote Supply Air Set Point — A remote supply air temperature set point reset can be supported when the controls expansion module is used. This input requires a 4 to 20 mA signal. It can be connected to terminals 8 and 9 on TB202.
- Remote Static Pressure Reset Set Point — A remote supply air temperature set point reset can be supported when the controls expansion module is used. This input requires a 4 to 20 mA signal. It can be connected to terminals 6 and 7 on TB202. This input is shared with the Outdoor Air IAQ signal.
- Outdoor Air IAQ Signal — If an external outdoor air signal is being used then it can be connected to terminals 6 and 7 on TB202. This input requires a 4 to 20 mA signal. This input is shared with the Remote Static Pressure Reset signal.
- IAQ Switch Input — If an external control will be controlling IAQ then it can be connected as a contact closure through terminals 12 and 13 on TB202.
- Space Humidity — A space humidity sensor can be used to enable the dehumidification and humidifier control logic. It can be connected to terminals 3 and 4 on TB202. This input requires a 4 to 20 mA signal.
- Humidifier Control Output — A contact closure out can be provided to enable the operation of a field-provided humidifier.

Carrier can also support electronic interface to other systems using the following:

- Modbus Carrier translator (read/write, provides CCN to Modbus remote terminal unit [RTU] protocol conversion)
- LonWorks Carrier translator (read/write, provides CCN to LON FT-10A ANSI/EIA-709.1 protocol conversion)

Constant volume and staged air volume applications

The 48/50N Series units are designed to operate in CV and SAV™ applications. The units are shipped as operable, stand-alone units using either a standard (mechanical or electronic) 2-stage heat, 2-stage cool thermostat, or with an electronic room temperature sensor.

With a standard thermostat (programmable is optional), heating and cooling operation is set by space temperature. With a space sensor, the machine will operate at default values unless they are changed using appropriate input devices. The space sensor monitors space temperature and may be equipped with a timed override feature, which allows unit operation during unoccupied periods. The space sensors may be used in multiples of 4 or 9 to achieve space temperature averaging. The use of a space sensor also allows the unit to be turned on and off from a remote

signal or it can be programmed to use the time of day scheduling that is built into the control.

Features with thermostat control of unit

- Two-stage heating (if installed)
- SCR electric heating if equipped with the SCR electric heat option
- Modulating gas heating if unit is equipped with the modulating gas heat option
- Two-stage demand with fully proportional economizers and integrated compressor capacity
- Adaptive multiple stage cooling which can provide up to 9 stages of capacity
- Control of unit using Y1, Y2, W1, W2, and G thermostat or T55, T56, or T58 space sensors
- Control of the indoor fan
- Outdoor-air temperature/supply-air temperature monitoring with logic to lock the compressors out at low ambient temperatures down to 32°F (-20°F with Motormaster® control)
- Control of a condenser fan based on outdoor-air and condensing pressures
- Control of modulating economizer to provide free cooling when outdoor conditions are suitable
- Control allows for use of the economizer and the compressors to maximize the use of outside air cooling to reduce part load operating costs
- Control of the power exhaust fan VFD based on configurable the building pressure sensor
- Compressor time guard override (power up and minimum on and off timers) to assure air return in low load conditions
- Automatic lead-lag control of compressors to reduce the number of compressor cycles
- Support of IAQ sensor

Features with sensor control of unit

There are 3 sensor options available:

- T55 sensor will monitor room temperature and provide unoccupied override capability (1 to 4 hours).
- T56 sensor will monitor room temperature, provide unoccupied override capability (1 to 4 hours), and provide a temperature offset of 5°F maximum.
- T58 is a CCN communicating sensor that will provide the set point and space temperature values.

Standard features are:

- Support of remote occupied/unoccupied input to start and stop the unit
- Two-stage economizer demand with fully proportional economizers and integrated compressor capacity
- Adaptive cooling capacity control with up to 9 stages of mechanical refrigeration capacity
- Variable capacity control with digital scroll compressor option
- Occupied or unoccupied set point
- Enable heating (if installed) or cooling during unoccupied periods as required to maintain space temperature within the unoccupied set points
- Adjustment of space temperature set points of $\pm 5^\circ\text{F}$ when using a T56 sensor
- Support of IAQ sensor

- 365-day timeclock with backup (supports minute, hour, and day of week, date, month, and year access). The timeclock includes the following features:
 - Daylight savings time function
 - Occupancy control with 8 periods for unit operation
 - Holiday table containing up to 18 holiday schedules
 - Ability to initiate timed override from T55 or T56 sensors (for a timed period of 1 to 4 hours) Temperature compensated start to calculate early start times before occupancy
 - For units connected into a CCN network the time clock can be integrated into the overall building energy management system and be updated remotely
 - For units connected to the CCN network the user can also display all the unit information including I/O values Maintenance, Configuration, Service, and Set Point data tables
 - Indoor air quality (IAQ)
 - Automatic lead-lag control of compressors to reduce the number of compressor cycles

Variable air volume (VAV) applications

The 48/50N Series units are designed to operate in VAV applications. They include a supply fan inverter (VFD) to control the supply fan speed and duct pressure. They are designed to control the leaving-air temperature in cooling to a configurable set point. The changes in mode of operation from Heating to Vent to Cooling mode can be controlled either from the return air temperature sensor or from an accessory space temperature sensor. Some of the features for VAV units in a stand-alone application are:

- Shipped as operable, stand-alone units that use the *ComfortLink* time of day scheduling routine
- Provide cooling and heating control (if equipped with heat) in both occupied and unoccupied modes
- Support an optional space temperature sensor for mode control and supply air temperature reset
- If space sensor is equipped with an override feature, the sensor will allow operation during the unoccupied period for a fixed length of time
- Base unit control supports a heat interlock relay (field supplied) to signal the VAV terminal devices to fully open during heating operation
- Control board diagnostics
- Control of an outdoor-condenser fan based upon outdoor-air temperature and saturated condensing temperature
- Control of modulating economizer to provide free cooling when outdoor conditions are suitable
- Control also allows for use of the economizer and the compressors to maximize the use of outside air cooling to reduce part load operating costs
- Support of remote occupied/unoccupied input to start
- Controls the operation of the supply fan inverter to maintain a configurable supply duct static pressure set point. Inverter is configured and controlled directly by *ComfortLink* controls
- Support of IAQ sensor
- Support a field test for field check out
- Support linkage to *ComfortID™* systems
- Cooling capacity control of up to 9 stages plus economizer
- Variable capacity control with digital scroll compressor option

- Control of two stages of heat to maintain return-air temperature
- SCR electric heating if equipped with the SCR electric heat option
- Modulating gas heating if unit is equipped with the modulating gas heat option
- Control of heat interlock relay
- Compressor time delays to prevent rapid cycling of compressors
- Automatic lead-lag control of compressors to reduce the number of compressor cycles
- With the addition of a remote start/stop switch, heating or cooling is enabled during unoccupied periods as required to maintain space temperature to within unoccupied set points
- With the addition of the controls expansion board, the *ComfortLink* controls will also support demand limiting and remote set point control

When the unit is connected to a CCN (Carrier Comfort Network®) system, additional features can be used:

- Interface of the unit clock with the CCN network clock to allow for remote configuration of the schedules
- CCN demand limit participation
- Interface with *ComfortID™* control systems through linkage

Sequence of operation

Cooling, constant volume (CV, SAV™) units

On power up, initialization software will determine the unit configuration and also initialize any controls loops and input/output devices. All alarms and configurations are saved in memory and maintained during power outages. All alarms will be maintained in memory and must be cleared through the display.

Constant volume and staged air volume conventional thermostat control

If the unit is equipped with a conventional thermostat with Y1, Y2, W1, W2, and G connections, then the control will perform the following sequence, controlled by the Multiple Adaptive Demand algorithm.

When G is closed, the indoor fan will turn on. G must be closed for heating or cooling to occur.

Cooling

If Y1 is closed, then the control will first check the ability to use the economizer. If the economizer can be used, the control will modulate the damper open to maintain the low load economizer leaving air temperature set point.

If Y2 is closed, then the control will lower the leaving air temperature set point to the configured set point. If the economizer cannot satisfy the load then compressors will be sequenced on to maintain either the low or high load temperature set points.

If the economizer cannot be used or the enable control disables the economizer, then the control will sequence the compressors based on the Y1 and Y2 signals. The control will add and remove compressor stages to maintain the low and high demand leaving air set points. If Y1 is closed at least one compressor stage will be turned on.

Heating

If W1 is closed, then it will indicate that the units should be in the Heating mode. The economizer will be closed to the

minimum position, and if the unit is equipped with gas or electric heat then the first stage of heat will be energized.

If W2 is closed, then the control will turn on the second stage of heat. If the unit is equipped with an SCR electric or modulating heat control option, then the W1 signal will be used to control the gas heat to the configurable low heat load leaving air temperature set point. When W2 is energized, the unit will fire all stages of heat capacity.

If the unit is equipped with gas heat, then the IGC board will control the operation of the gas heat. See the 48 Series Gas Heat units section for the IGC board sequence of operation.

If the unit has the hydronic heat option, then the W1 signal will control the modulating control valve to the configurable low heat load leaving air temperature set point. When W2 is energized, the modulating control valve will go to a 100% open position.

Constant volume and staged air volume space temperature sensor control

If the space temperature operation has been selected using a T55, T56, or T58 sensor, then the following logic will be used to control the operation of the unit. If a space temperature is used, then a wire jumper must be added between R, W1, and W2.

If a remote occupancy control method has been selected, then the input must first be closed for the unit to go into Heat, Vent, or Cooling mode. If the internal timeclock is used, the control module determines the occupancy state based on the system time schedules.

If Temperature Compensated Start is active, the unit will be controlled as in the occupied mode and will start a time as determined by prior operation to have the space at set point by the occupied time.

Vent

If the unit has been configured for a pre-occupancy purge, then the control will start the unit in Vent mode prior to the occupancy time to vent the space. If an IAQ sensor is being used and the low IAQ set point is satisfied, then the occupancy purge mode will be terminated. The set points for heat and cooling are configurable through the display. If a T56 sensor is being used, then the set point can be shifted by as much as 5 degrees.

Cooling

If the space temperature goes above the cooling set point then the unit will go into Cooling mode, controlled via the Multiple Staged Evaporator Discharge Temperature algorithm. If the economizer can be used, the control will first try to control to the leaving air temperature set point. The set point will depend on the space temperature. If the temperature is above the low demand set point, then the low economizer load discharge air temperature set point will be used. If the temperature is above the high load space temperature set point, then the high load leaving air temperature set point will be used. If the economizer cannot satisfy the load, then compressors will be sequenced on to maintain either the low or high load temperature set points.

If the economizer cannot be used or the enable control disables the economizer, then the control will sequence the compressors based on the low and high load space temperature variables. The control will add and remove compressor stages to maintain the high and low demand leaving air set points.

Heating

If the space temperature goes below the heating space temperature set points, then it will indicate that the units should be in the Heating mode. The economizer will be closed to the minimum position and, if the unit is equipped with gas or electric heat, then the first stage of heat will be energized.

If the space temperature goes below the high load space temperature set point, then the control will turn on the second stage of heat. If the unit is equipped with modulating gas heat control or SCR electric heat option, then the low load demand signal will continuously modulate the heating load to maintain the leaving air temperature set point. A high demand signal will energize all stages of heat. The gas modulating section will operate at maximum heating capacity if the modulating option is selected.

If the unit has the hydronic heat option, then the low load demand signal will control the modulating control valve to the configurable low heat load leaving air temperature set point. A high demand signal will cause the modulating control valve to go to a 100% open position.

Unoccupied Mode

If the unit is configured for unoccupied free cooling, mechanical cooling, or heating and the temperature goes beyond the unoccupied configuration set points, then the control will turn on free cooling, mechanical cooling, or heat as needed to get within the unoccupied set points. When in this mode, the economizer dampers will be maintained fully closed or to the minimum unoccupied ventilation set point.

Variable air volume control

On power up, the control module will activate the initialization software. The initialization software will determine the unit configuration and also initialize any controls loops and input/output devices.

All alarms and configurations are saved in memory and maintained during power outages. All alarms will be maintained in memory and must be cleared through the display.

The unit will first determine the mode of operation. If the unit has been configured for space temperature demand then the control will determine, based on the configurable set points, if the unit should be in the heat mode, vent mode, or cooling mode. If the unit is configured for return air temperature control, then it will start the fan and monitor the return air temperature vs. the configurable set point to determine if the unit should be in cooling, vent, or heating mode.

If the control is connected to a ComfortID system, the room terminals are equipped with microprocessor controls that give commands to the base module. If linkage is active, the control module will replace local *ComfortLink* set points and occupancy data with linkage supplied data.

Vent

If temperature compensated start is active, then advance pre-cool or heat of the space is enabled. If the unit is configured to use a pre-purge cycle, then the *ComfortLink* controls will start the unit in Vent mode based on a prestart time interval. If an IAQ sensor is being used and the low IAQ control point is satisfied, then the mode will be terminated.

Cooling

If Cooling mode is required, then the controlling set point will be the leaving air temperature set point, controlled via the Multiple Staged Evaporator Discharge Temperature algorithm. If an economizer is present and the changeover control

allows the economizer to be used, then it will first attempt to control the leaving-air temperature using free cooling. If this cannot satisfy the load, then additional compressor stages will be turned on to maintain the leaving-air temperature.

When both compressors and economizers are being used, the control will use the economizer dampers to maintain better control of the leaving-air temperature and to help prevent high compressor cycling. If the economizer cannot be used, then it will be set to the minimum vent position. When using compressors, the leaving-air temperature will sequence compressors on and off using a PID control loop.

If the unit is equipped with an optional hot gas bypass valve, the control will use the hot gas as an additional stage of capacity. When the first stage of cooling is required the control will turn on a circuit "A" compressor and the hot gas bypass valve. When additional cooling is called for it will turn off the hot gas bypass valve. The valve will also be used for additional freeze protection of the coils when low evaporator refrigerant temperatures are detected using the suction pressure transducers.

When operating in cooling mode, the control will also monitor the supply duct pressure and send a 4 to 20 mA signal to the factory-supplied inverter to control the speed of the fan and the delivered cfm. If on a linkage system, the control will also support static pressure reset based on the needs of the zones.

Heating

If the unit has been enabled for occupied heat and the space temperature sensor (SPT), return air temperature sensor (RAT), or linkage demand calls for heat, the control will energize the electric heat or gas heat (if present) to warm the space.

In this mode the control will energize the heat interlock relay which will signal the terminals to open to the heating position. Note that for the linkage systems the interlock relay connection is not required. Once the Heat mode is enabled, the heat capacity will be controlled by the return air temperature set point. Heating will continue until the return temperature set point is satisfied. If the unit is configured for morning warm-up and the heating demand is below the set point during the first 10 minutes of operation, the control will energize full heating capacity until the return air temperature set point is satisfied.

If the space temperature sensor (SPT), return air temperature sensor (RAT) or linkage demand requires that the unit be in heating mode, then the control will energize the electric heat or gas heat (if present) to warm the space. In this mode the control will energize the heat interlock relay which should be connected to the terminals to indicate that they should open to the heating position. The interlock relay connection is not required for the linkage systems. Heating will continue until the mode selection sensor is satisfied.

Dehumidification mode

A Dehumidification mode can be initiated by either a discrete input on TB202 or by a direct measurement of humidity levels with an optional space or return air humidity sensor. When the Dehumidification mode is active, the evaporator coil leaving air temperature will be controlled to the Dehumidify Cool set point, which is typically colder than the normal cool mode leaving air set points.

In this mode, comfort condition set points, which are based on dry bulb temperature, will be overridden. If a source of reheat is available, then the leaving-air temperature can be raised to a more desirable temperature. Available methods

of reheat are modulating hot water heat, steam, or heat reclaim if the unit is equipped with the appropriate coil.

Humidi-MiZer® operation

The design of the Humidi-MiZer adaptive dehumidification system modulates between two humidity control modes of operation of the rooftop unit, utilizing a common subcooling/reheat dehumidification coil located downstream of the standard evaporator coil.

This unique and innovative design provides the capability for the rooftop unit to operate in both a subcooling mode and a hot gas reheat mode for maximum system flexibility.

The Humidi-MiZer package is factory-installed and will operate whenever there is a dehumidification requirement. The Humidi-MiZer system is initiated based on input from a factory-installed return air humidity sensor to the large rooftop unit controller. Additionally, the unit controller may receive an input from a space humidity sensor, a discrete input from a mechanical humidistat, or a third-party controller. A unit equipped with a Humidi-MiZer system can operate in the following modes:

Conventional Cooling Mode

Conventional operation of the N Series large rooftop unit allows the unit to cycle up to 8 compressors to maintain comfort conditions, with expanded cycling operation offered by the optional digital compressor.

This mode is the conventional DX (direct expansion) cooling method used on Carrier's standard large rooftops and provides equivalent capacity to a non-Humidi-MiZer equipped unit. It is used when there is a call for cooling only, such as at design AHRI (Air-Conditioning, Heating, and Refrigeration Institute) cooling conditions of 95°F ambient and 80°F/67°F db/wb entering air conditions. The SHR (sensible heat ratio) for equipment in this scenario is typically 0.7 or higher.

Subcooling Mode

This mode will modulate to satisfy part load type conditions when there is a space call for cooling and dehumidification. Although the temperature (sensible) may have dropped and decreased the sensible load in the space, the outdoor and/or space humidity levels may have risen. A typical scenario might be when the outside air is 85°F and 70 to 80% relative humidity (RH). Desired SHR for equipment in this scenario is typically 0.4 to 0.7. Carrier's N Series Humidi-MiZer adaptive dehumidification will increase subcooling entering the evaporator and cycle on enough compressors to meet the latent load requirement, while simultaneously adjusting refrigerant flow to the Humidi-MiZer coil to reheat the air to the required supply air set point. This will allow the unit to provide variable SHR to meet space requirements.

Conversely, a standard unit might overcool the space or stage down to meet set point, sacrificing latent capacity control. The Humidi-MiZer unit will initiate subcooling mode when the space temperature and humidity are both above the temperature and humidity set points, and attempt to meet both requirements.

Once the humidity requirement is met, the unit can continue to operate in normal cooling mode to meet any remaining sensible capacity load. Alternatively, if the sensible load is met and humidity levels remain high, the unit can switch to Hot Gas Reheat mode to provide neutral, dehumidified air.

Hot Gas Reheat Mode

This mode is used when dehumidification is required without a need for cooling, such as when the outside air is at a neutral temperature (70 to 75°F) but high humidity exists. This situation requires the equipment to operate at a SHR of 0.0 to 0.2.

With no cooling requirement and a call for dehumidification, the N Series Humidi-MiZer adaptive dehumidification system will cycle on enough compressors to meet the latent load requirement, while simultaneously adjusting refrigerant flow to the Humidi-MiZer® coil to reheat the air to the desired neutral air set point.

The N-Series Humid-MiZer system controls allow for the discharge air to be reheated to either the return-air temperature minus a configurable offset or to a configurable Reheat set point (default 70°F). The Hot Gas Reheat mode will be initiated when only the humidity is above the humidity set point, without a demand for cooling.

Mode Control

The essential difference between the Subcooling mode and the Hot Gas Reheat mode is in the supply air set point. In Subcooling mode, the supply air set point is the temperature required to provide cooling to the space. In Reheat mode, the supply air set point is the temperature required to provide neutral air to the space. In both cases, the unit will decrease the evaporator discharge temperature to meet the latent load and reheat the air to the required cooling or reheat set point (i.e., 50, 60, 70°F, etc.).

48 Series gas heat units

The gas heat units incorporate 2 to 5 separate systems, depending on unit size and heating capacity, to provide gas heat. Each system incorporates its own induced-draft motor, integrated gas control (IGC) board, 2-stage gas valve, manifold, and safeties. The modulating system incorporates an additional modulating gas valve and modulating gas control.

For 2-stage heat control the systems are operated in parallel. For example, when there is a call for first stage heat, both induced-draft motors operate, both gas valves are energized, and both IGC boards initiate spark.

With the modulating gas control, the systems are operated independently to allow for a greater range of capacity control. All of the gas heating control is performed through the IGC boards (located in the heating section). There are two additional boards (TR1 and SC30) for the modulating system, which in combination with the IGC board control the modulating gas heating. The additional boards are also located in the heating section.

The MBB module board serves only to initiate and terminate heating operation and monitor the status of the requirements for indoor fan operation. The fan will be controlled directly by the MBB board. When the thermostat or room

sensor calls for heating the MBB board will close heating relays and send power to W on each of the IGC boards.

An LED on the IGC board will be on during normal operation. A check is made to ensure that the rollout switches and limit switches are closed and the induced-draft motors are not running. After the induced-draft motors are energized, the speed is proven with the Hall Effect sensor on the motor or, for units with modulating gas heat, the inducer-draft motor function is proven with a pressure switch.

When the motor speed or function is proven, the ignition activation period begins. The burners will ignite within 5 seconds. When ignition occurs the IGC board will continue to monitor the condition of the rollout and limit switches, the flame sensor, the Hall Effect sensor, or the pressure switch.

If the unit is controlled through a room thermostat set for fan auto, 45 seconds after ignition occurs the indoor-fan motor will be energized and the outdoor-air dampers will open to their minimum position. If the overtemperature limit opens prior to the start of the indoor-fan blower, on the next attempt the 45-second delay will be shortened to 5 seconds less than the time from initiation of heat to when the limit tripped. Gas will not be interrupted to the burners and heating will continue. Once modified, the fan on delay will not change back to 45 seconds unless power is reset to the control and IGC.

If the unit is controlled through a room sensor, the indoor fan will be operating in the occupied mode and the outdoor-air dampers will be in the minimum position. If the unit is controlled with a room sensor in the unoccupied mode, the indoor fan will be energized through the IGC board with a 45-second delay and the outside-air dampers will move to the minimum unoccupied set point. When additional heat is required, the second stage MBB output relay closes and initiates power to the second stage of all main gas valves in all sections.

For units equipped with modulating system, the second stage is controlled by the TR1 timer relay board. When the demand is satisfied, MBB heat output relays will open and the gas valves close, interrupting the flow of gas to the main burners. If the call for stage 1 heat lasts less than 1 minute, the heating cycle will not terminate until 1 minute after W1 became active.

If the unit is configured for intermittent fan, then the indoor fan motor will continue to operate for an additional 45 seconds, then stop and the outdoor-air dampers will close. If the overtemperature limit opens after the indoor motor is stopped within 10 minutes of W1 becoming inactive, on the next cycle the time will be extended by 15 seconds. The maximum delay is 3 minutes. Once modified, the fan off delay will not change back to 45 seconds unless power is reset to the control.

Ductwork

Secure vertical discharge ductwork to the roof curb. Interior installation may proceed before the unit is set in place on the roof. For horizontal discharge applications, attach the ductwork to the 1¹/₄ in. flanges on the side of the unit. Vertical discharge units equipped with electric heat require a 90-degree elbow below the unit supply duct connection.

Thru-the-curb service connections

Roof curb connections allow field power wires and control wires to enter through the roof curb opening.

Thermostat (CV only)

Use of a thermistor-type room sensor is recommended on all CCN or BACnet installations. A thermistor-type room sensor or a 2-stage heating/cooling thermostat may be used for all other units.

Heating-to-cooling changeover

All units are automatic changeover from heating to cooling.

Airflow

Units are draw-thru on cooling and blow-thru on heating.

Maximum airflow

To minimize the possibility of condensate blow-off from the evaporator, airflow through units should not exceed values shown in the Unit Design Airflow Limits table on page 10.

Minimum airflow

The minimum cooling airflow for units with standard compressors is 300 CFM/ton. Variable air volume (VAV) units with variable capacity compressors can operate down to 200 CFM/ton under most conditions. Contact application engineering for applications requiring lower airflow or non-standard conditions. Refer to Gas Heating Capacities and Electric Heating Capacities tables on pages 11 and 12 for minimum heating airflow.

Minimum ambient cooling operation temperature

All units may be equipped with factory-installed economizers to allow free cooling at any outdoor ambient. If mechanical cooling is required, the units are designed to operate with outdoor-air temperatures down to 32°F. Units equipped with the low ambient control option or with the Motormaster® V accessory can operate with outdoor temperatures down to -20°F. Outdoor-fan motor change out may be required for Motormaster V applications. Carrier recommends the installation of field-fabricated wind baffles when operating in environments with prevailing winds of

more than 5 mph and where outdoor-air temperatures drop below 32°F.

Maximum operating outdoor-air temperature

The maximum operating outdoor-air temperature is 115°F. High-efficiency models will operate up to 125°F.

High altitude (gas heat units only)

A change to the gas orifice may be required at high altitudes. Contact Carrier Application Engineering.

Minimum temperature

The minimum allowable temperature of mixed air entering the gas heat exchanger during low rate (first stage) operation is 50°F. There is no minimum mixture temperature during full-rate operation. Comfort conditioning may be compromised at mixed-air temperatures below 50°F. Below 50°F entering-air temperature (EAT), both stages of heat are engaged.

Internal unit design

Due to Carrier's internal unit design (draw-thru over the motor), air path, and specially designed motors, the full horsepower listed in the Physical Data table and Motor Limitations table can be utilized with extreme confidence. Using Carrier motors with the values listed in the Physical Data and Motor Limitations tables will not result in nuisance tripping or premature motor failure. The unit warranty will not be affected.

Electric heat

On vertical discharge units, a field-supplied 90-degree elbow must be installed in the supply ductwork below the unit discharge.

Hydronic heat

Application of hydronic coils and steam heating coils in outdoor located equipment should always be considered very carefully. The design of such systems should provide for low temperature protection in the event of a power failure to the unit.

Auxiliary coil

The 48/50N units with extended chassis are capable of accepting field-supplied and installed auxiliary coils (e.g., heat reclaim coils). These units include coil tracks and face framing to facilitate the installation of auxiliary coils. The figure below shows dimensions on coil track locations inside these units. The Auxiliary Coil Frame Dimensions table shows dimensions for the auxiliary coil.

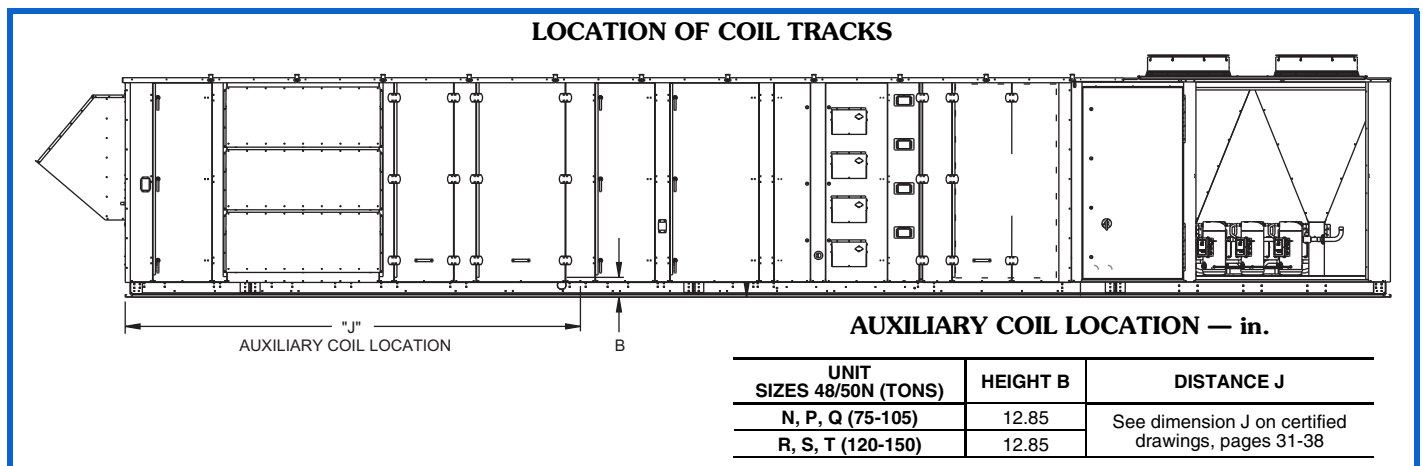

AUXILIARY COIL FRAME DIMENSIONS (in.)

UNIT SIZE 48/50N (TONS)	75-105	120-150
Casing Depth	12.0	12.0
Casing Height	64.4	74.4
Casing Length*	116.3	116.3
Overall Length†	133.5	133.5

* Longer casing lengths possible but modifications to face framing sheet metal will be required during installation.

† Represents the maximum overall length of the coil plus all piping and coil control devices located inside the air handler cabinet.

Application of hydronic coils and steam heating coils in outdoor located equipment should always be considered very carefully. Design such systems for low temperature protection in the event of power failure to the unit.

Steam coils are typically not recommended for installation in outdoor located equipment, due to added space required for fluid control and need to protect all piping and controls in the event of power failure to the building and/or the unit. Consider installing small steam-to-hydronic heat

exchangers with circulating pump to deliver hydronic fluids out to the auxiliary coil in the air conditioner unit.

Steel beam mounting

To offer additional flexibility for roof or grade level mounting, Carrier accepts mounting units on steel beams. This mounting style is commonly used to aid in vibration/acoustic isolation, minimize roof penetrations, or expand use of roof real estate.

To protect unit insulation on bottom, it is recommended for units to include "Double Wall on-the-bottom" special order. This special order will deliver a double wall floor design and encase the standard insulation in galvanized sheet metal.

NOTE: "Double Wall on-the-bottom" is not compatible with roof curbs.

Carrier requires structural I-beam style-supports along the entire length of a unit. Additionally, to aid in maintaining dimensions of the rails and providing increased weight distribution, Carrier prefers 2 end-cross rails, and intermediate cross rails evenly spaced every 6 to 8 ft.

48/50N STEEL BEAM MOUNTING

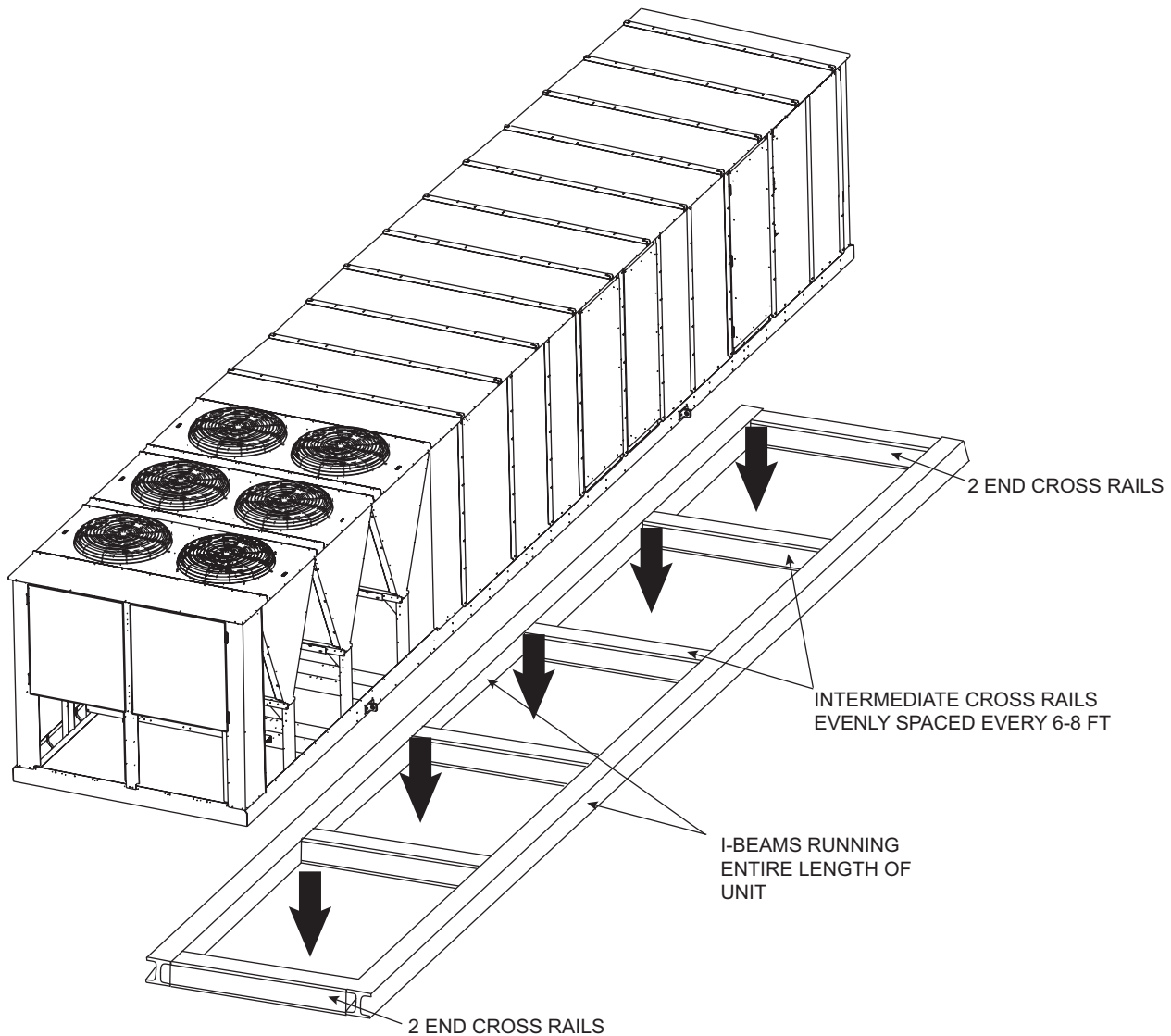

MULTIPLE UNIT MINIMUM SEPARATION

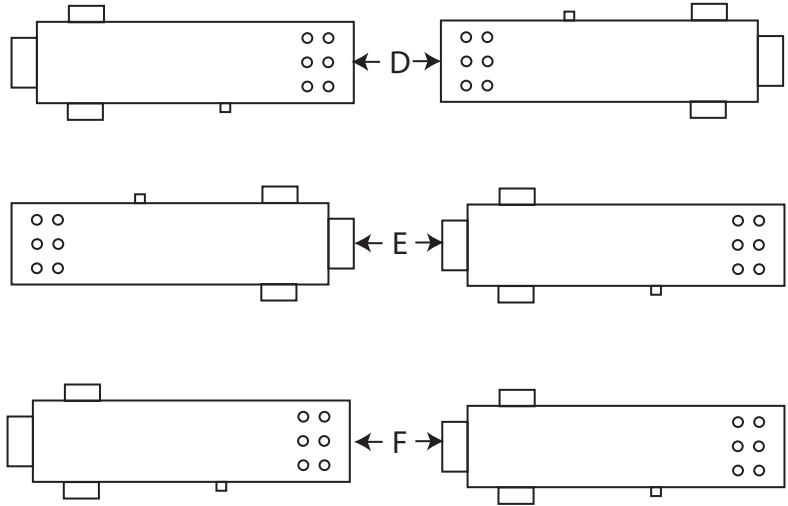
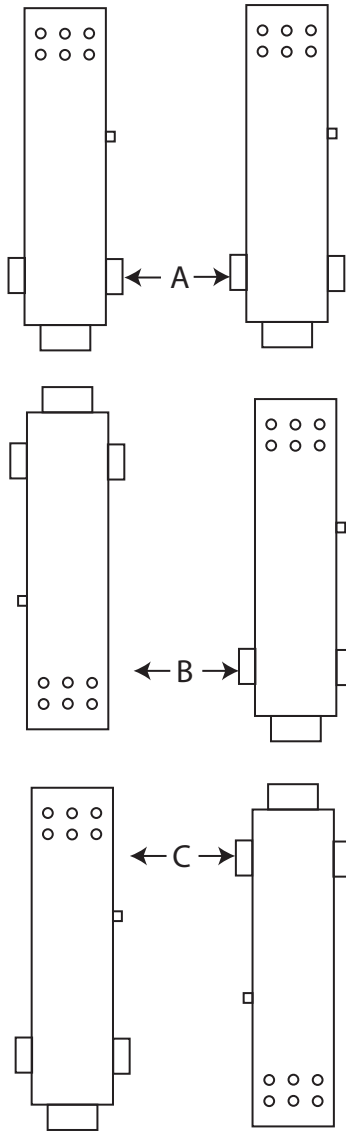

MINIMUM SPACING (ft)

UNIT	A	B	C	D	E	F
48 Series	12	8	12	10	10	10
50 Series	10	8	8	10	10	10

Acoustical considerations

To minimize sound transmitted to the space, please conform to the following recommendations:

Location

- Avoid locating the unit above sound-sensitive areas. Instead, locate the unit above restrooms, storage areas, corridors, or other noise-tolerant areas.
- Avoid mounting the unit in the middle of large roof expanses between vertical supports. This will minimize the phenomenon known as roof bounce.
- Install the units close to vertical roof supports (columns or load bearing walls).
- Locate the units at least 25 ft away from critical areas. If this is not possible, the ductwork and ceiling structure should be acoustically treated.
- Consider the use of vibration isolators or an acoustic curb.

Ductwork

- Utilize flexible connectors between the unit and the supply and return ducts.
- Supply and return air main trunk ducts should be located over hallways and/or public areas.
- Provide trailing edge turning vanes in ductwork elbows and tees to reduce air turbulence.
- Make the ductwork as stiff as possible.
- Use round duct wherever possible because it is less noisy.

- Seal all penetrations around ductwork entering the space.
- Make sure that ceiling and wall contractors do not attach hangers or supports to ductwork.
- Provide as smooth and gradual transition as possible when connecting the rooftop unit discharge to the supply duct.
- If a ceiling plenum return is utilized, provide a return elbow or tee to eliminate line-of-sight noise to the space. Face the entrance of the return duct away from other adjacent units.

Acoustic insulation

- Provide acoustic interior lining for the first 20 ft of supply and return duct or until the first elbow is encountered. The elbow prevents line-of-sight transmission in the supply and return ducts.
- Install a double layer of 2-in. low density quilted fiberglass acoustical pad with a 1/8-in. barium-loaded vinyl facing on top of the roof deck before building insulation and roofing installation occur. Place the material inside the curb and for 4 to 8 ft beyond the unit perimeter, dependent upon unit size (larger units require a wider apron outside the curb). Openings in the pad should only be large enough for the supply and return ducts. An alternate approach is to use two layers of gypsum board with staggered seams in addition to the acoustical pad.

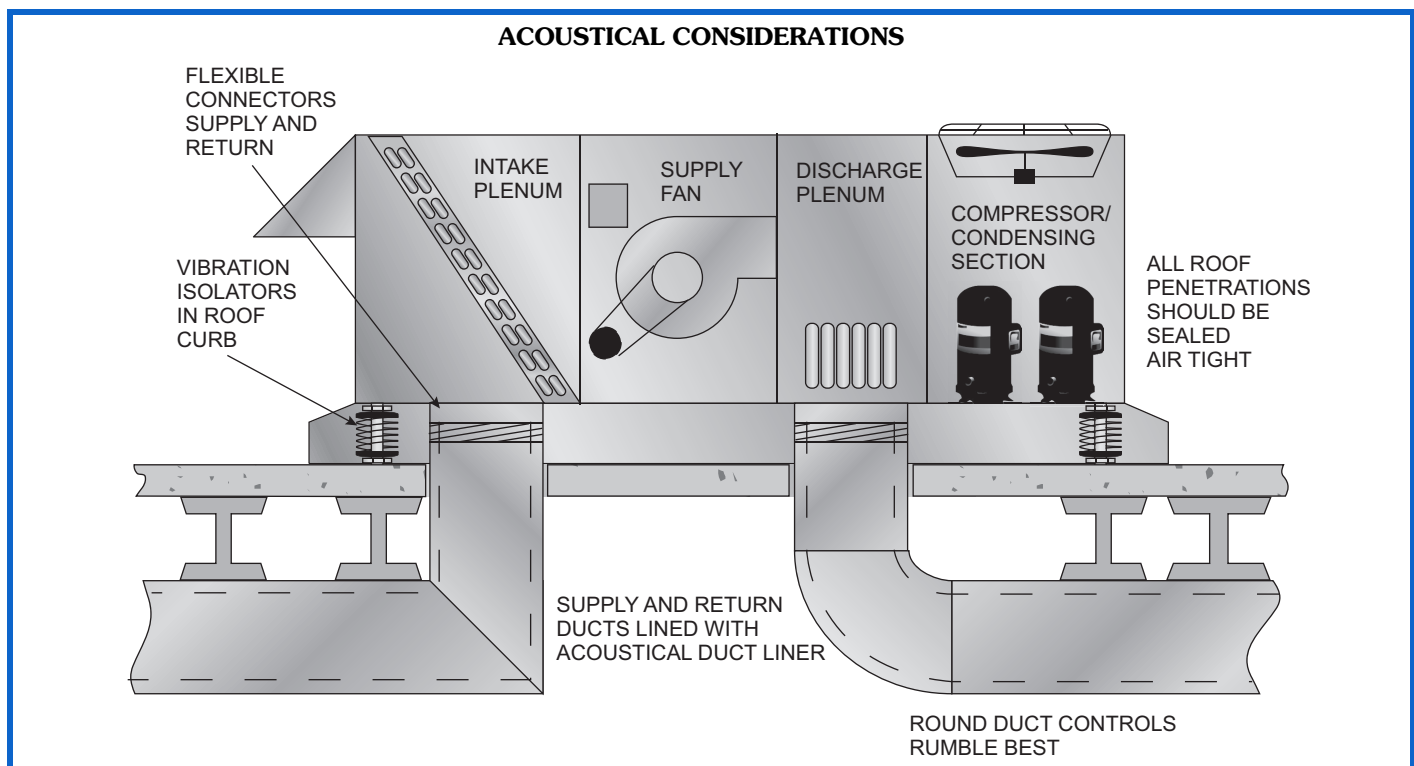

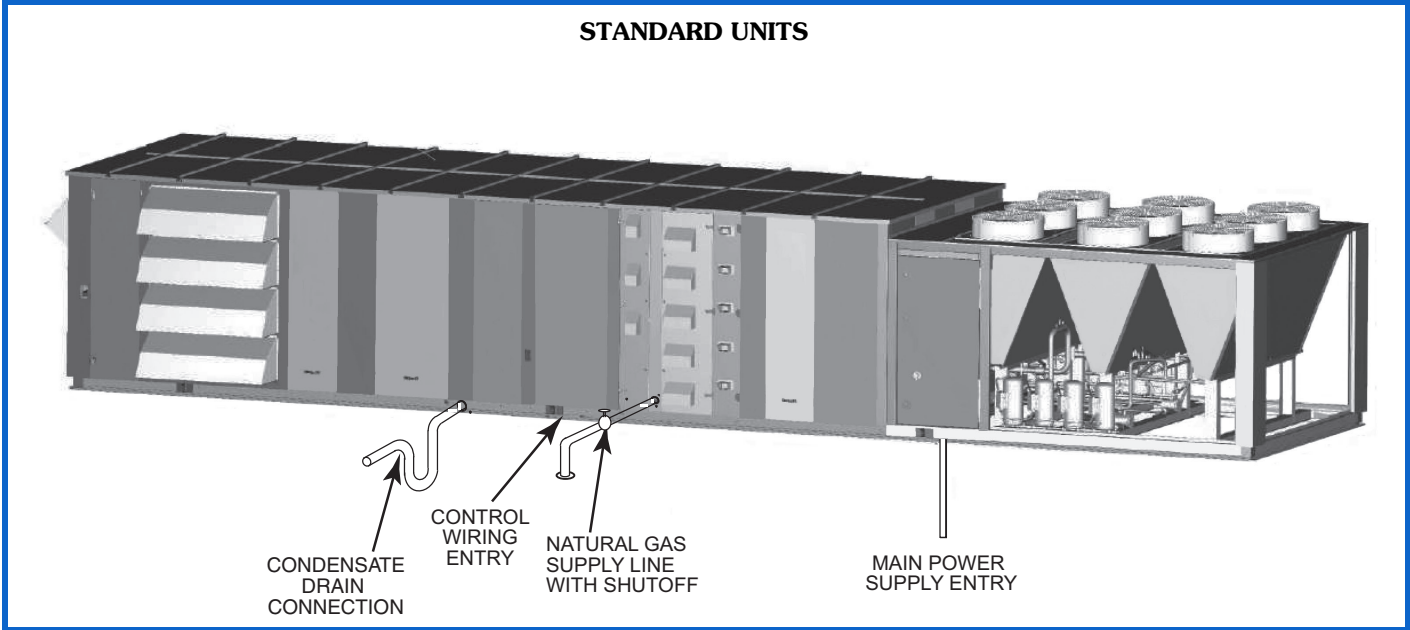

POWER SCHEMATIC — SIZE N SHOWN (75 TON NOMINAL CAPACITY)

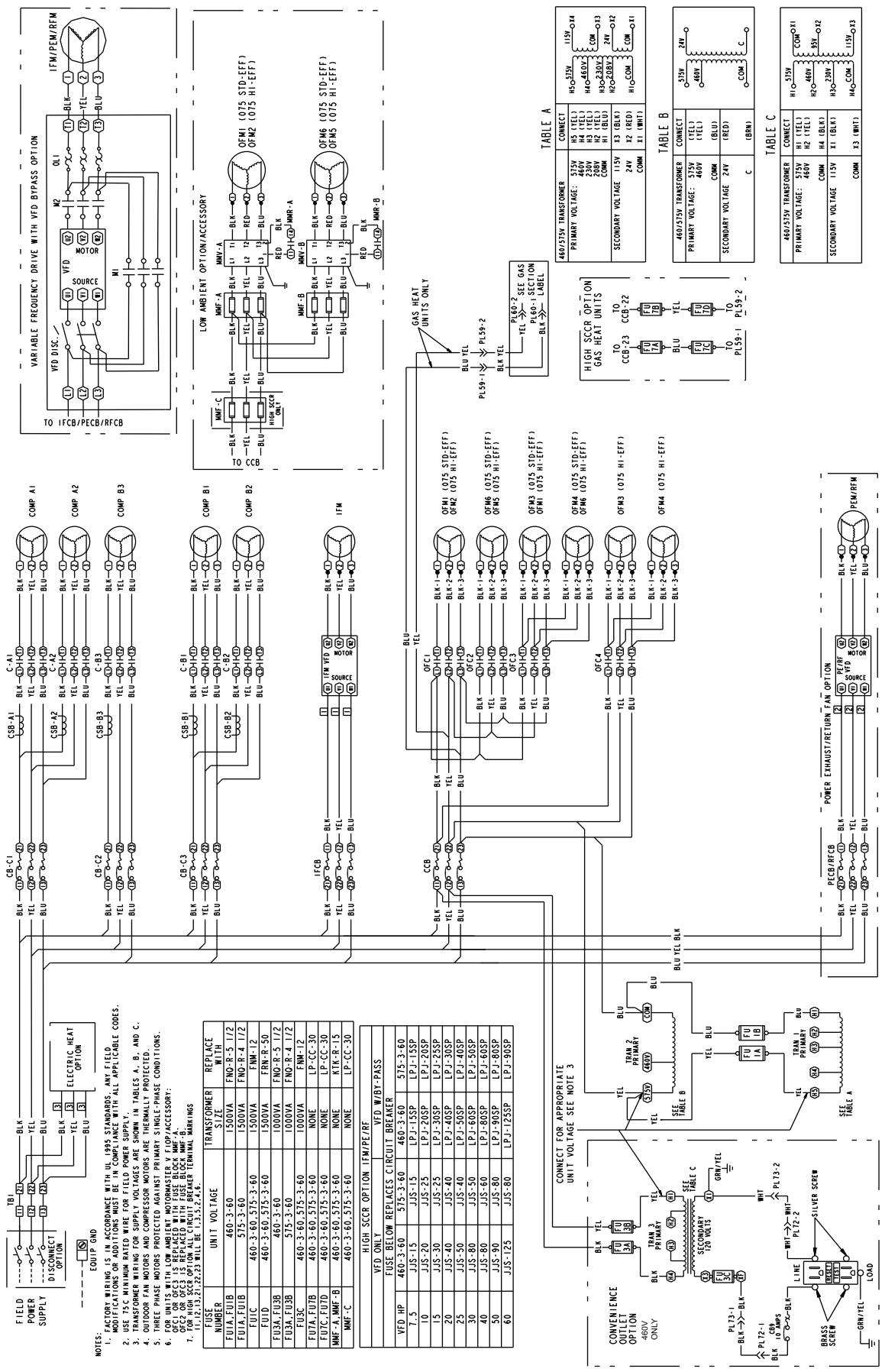

- NOTES:**
1. FACTORY WIRING IS IN ACCORDANCE WITH UL 1995 STANDARDS. ANY FIELD MODIFICATIONS OR ADDITIONS MUST BE IN COMPLIANCE WITH ALL APPLICABLE CODES.
 2. WIRING FOR SUPPLY VOLTAGES ARE SHOWN IN TABLES A, B, AND C.
 3. TRANSFORMER WIRING FOR SUPPLY VOLTAGES ARE SHOWN IN TABLES A, B, AND C.
 4. OUTDOOR FAN MOTORS AND COMPRESSOR MOTORS ARE THERMALLY PROTECTED.
 5. THREE PHASE MOTORS PROTECTED AGAINST PRIMARY SINGLE-PHASE CONDITIONS.
 6. FOR UNITS WITH LOW AMBIENT MOTOMASTER VFD/PT/ACCESSORY: OFC2 OR OFC3 IS REPLACED WITH FUSE BLOCK MMF-B.
 7. FOR HIGH SECTOR OPTION ALL CIRCUIT BREAKER TERMINAL MARKINGS (150, 151, 152, 153, 154, 155) WILL BE 152, 153, 154, 155.

FUSE NUMBER	UNIT VOLTAGE	TRANSFORMER SIZE	REPLACE WITH
FU1A, FU1B	460-3-60	1500VA	FNO-R-5 1/2Z
FU1A, FU1B	575-3-60	1500VA	FNO-R-4 1/2Z
FU1C	460-3-60, 575-3-60	1500VA	FNM-1Z
FU1D	460-3-60, 575-3-60	1500VA	FRN-R-50
FU3A, FU3B	460-3-60	1000VA	FNO-R-5 1/2Z
FU3A, FU3B	575-3-60	1000VA	FNO-R-4 1/2Z
FU3C	460-3-60, 575-3-60	1000VA	FNM-1Z
FU4A, FU4B	460-3-60, 575-3-60	NONE	LP-CC-30
FU4C, FU4D	460-3-60, 575-3-60	NONE	LP-CC-30
MMF-A, MMF-B	460-3-60, 575-3-60	NONE	RTK-R-15
MMF-C	460-3-60, 575-3-60	NONE	LP-CC-30

VFD ONLY	W/DBY-PASS
FUSE BELOW REPLACES CIRCUIT BREAKER	
VFD HP	460-3-60
7.5	JJS-15
10	JJS-20
15	JJS-30
20	JJS-40
25	JJS-50
30	JJS-60
40	JJS-80
50	JJS-90
60	JJS-125

CONNECT FOR APPROPRIATE UNIT VOLTAGE SEE NOTE 3
460/575V TRANSFORMER
PRIMARY VOLTAGE: 575V
480V (YEL)
480V (BLU)
208V (RED)
208V (WHT)
COMM
SECONDARY VOLTAGE 115V
X3 (BLK)
X2 (RED)
X1 (WHT)

CONNECT
460/575V TRANSFORMER
PRIMARY VOLTAGE: 575V
480V (YEL)
480V (BLU)
24V (RED)
24V (WHT)
COMM
SECONDARY VOLTAGE 24V
X3 (WHT)
X2 (RED)
X1 (BLU)

CONNECT
460/575V TRANSFORMER
PRIMARY VOLTAGE: 575V
480V (YEL)
480V (BLU)
24V (RED)
24V (WHT)
COMM
SECONDARY VOLTAGE 24V
X3 (WHT)
X2 (RED)
X1 (BLU)

CONNECT
460/575V TRANSFORMER
PRIMARY VOLTAGE: 575V
480V (YEL)
480V (BLU)
115V (WHT)
115V (BLK)
COMM
SECONDARY VOLTAGE 115V
X3 (WHT)
X2 (BLK)
X1 (BLU)

CONNECT
460/575V TRANSFORMER
PRIMARY VOLTAGE: 575V
480V (YEL)
480V (BLU)
115V (WHT)
115V (BLK)
COMM
SECONDARY VOLTAGE 115V
X3 (WHT)
X2 (BLK)
X1 (BLU)



POWER SCHEMATIC — SIZES P, Q, R, S, T SHOWN (90-150 TON NOMINAL CAPACITY)

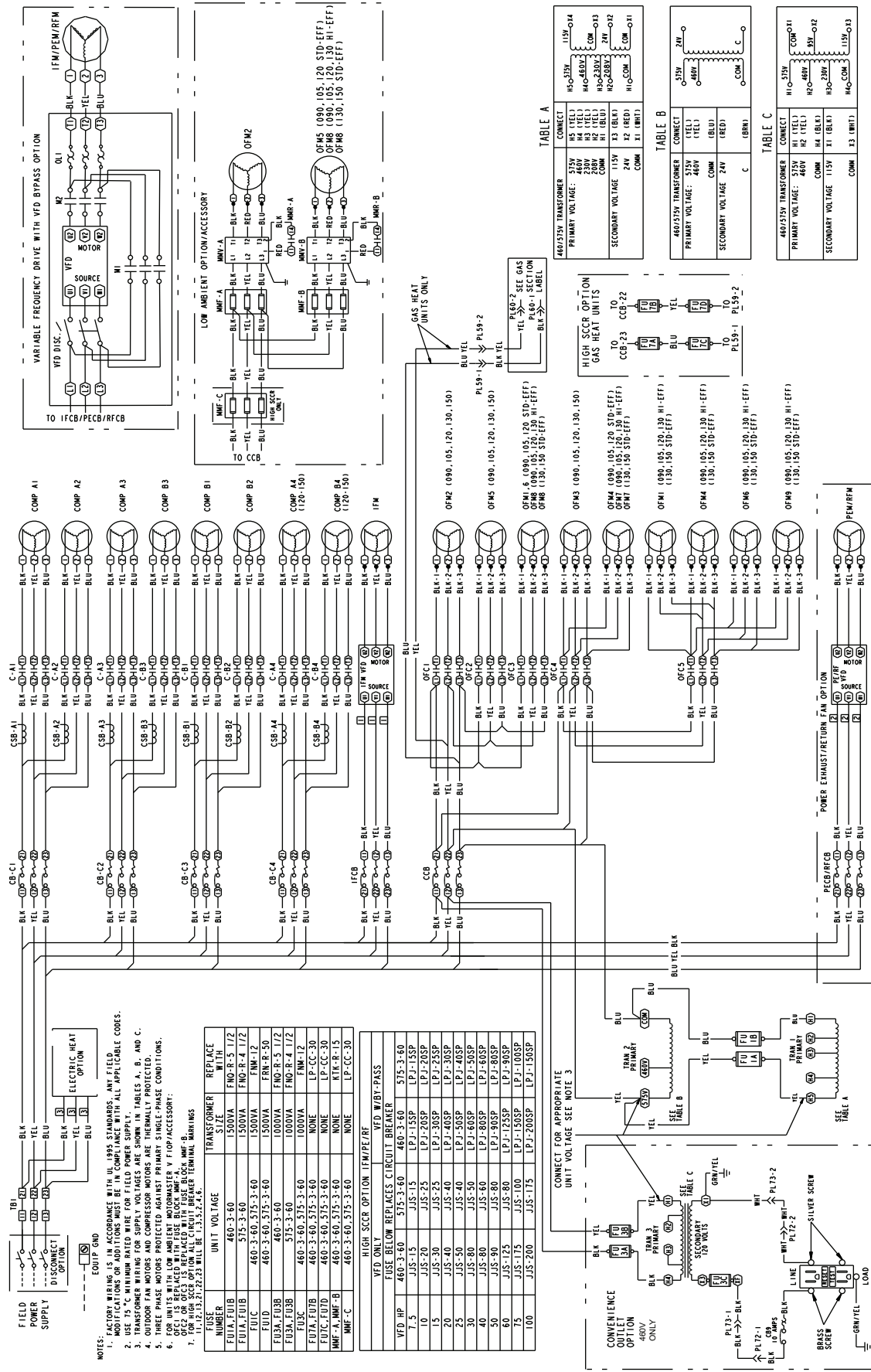

- NOTES:**
1. FACTORY WIRING IS IN ACCORDANCE WITH ALL APPLICABLE STANDARDS. ANY FIELD MODIFICATIONS OR ADDITIONS MUST BE IN COMPLIANCE WITH ALL APPLICABLE CODES.
 2. USE 75 °C WIRING RATED FOR WIRE FOR FIELD POWER SUPPLY.
 3. TRANSFORMER RATINGS FOR SUPPLY VOLTAGES ARE SHOWN IN TABLES A, B, AND C.
 4. OUTDOOR FAN MOTORS AND COMPRESSOR MOTORS ARE THERMALLY PROTECTED.
 5. REFER TO THE FOLLOWING PAGES FOR ELECTRICAL CONNECTIONS AND WIRING INSTRUCTIONS.
 6. ODFC IS REPLACED WITH IN FUSE BLOCK MMF-A, MMF-B, MMF-C.
 7. FOR HIGH SCCR OPTION ALL CIRCUIT BREAKER TERMINAL MARKINGS 1, 11, 12, 13, 21, 22, 23 WILL BE 1, 1.5, 2, 2.4, 6.

USER	UNIT VOLTAGE	TRANSFORMER	REPLACE
F1A, F1B	480-3-60	1500VA	FMO-R-5 1/2
F1A, F1B	575-3-60	1500VA	FMO-R-4 1/2
F1C	480-3-60, 575-3-60	1500VA	FMM-12
F1D	480-3-60, 575-3-60	1500VA	FRM-R-50
F13A, F13B	480-3-60	1000VA	FMO-R-5 1/2
F13C	575-3-60	1000VA	FMO-R-4 1/2
F17A, F17B	480-3-60, 575-3-60	NONE	FMM-12
F17C, F17D	480-3-60, 575-3-60	NONE	LP-CC-30
MMF-A, MMF-B	480-3-60, 575-3-60	NONE	RTK-R-15
MMF-C	480-3-60, 575-3-60	NONE	LP-CC-30

VFD ONLY		HIGH SCCR OPTION, IFM/PE/R	
FUSE BELOW REPLACES CIRCUIT BREAKER	W/B/Y/PASS	FUSE BELOW REPLACES CIRCUIT BREAKER	W/B/Y/PASS
VFD HP	480-3-60, 575-3-60	480-3-60	575-3-60
7.5	JJS-15	LPJ-15SP	LPJ-15SP
10	JJS-20	LPJ-20SP	LPJ-20SP
15	JJS-30	LPJ-30SP	LPJ-30SP
20	JJS-40	LPJ-40SP	LPJ-40SP
25	JJS-50	LPJ-50SP	LPJ-50SP
30	JJS-60	LPJ-60SP	LPJ-60SP
40	JJS-80	LPJ-80SP	LPJ-80SP
50	JJS-90	LPJ-90SP	LPJ-90SP
60	JJS-100	LPJ-100SP	LPJ-100SP
75	JJS-115	LPJ-115SP	LPJ-115SP
100	JJS-200	LPJ-200SP	LPJ-200SP

CONTROL SECTION — 48/50N UNITS

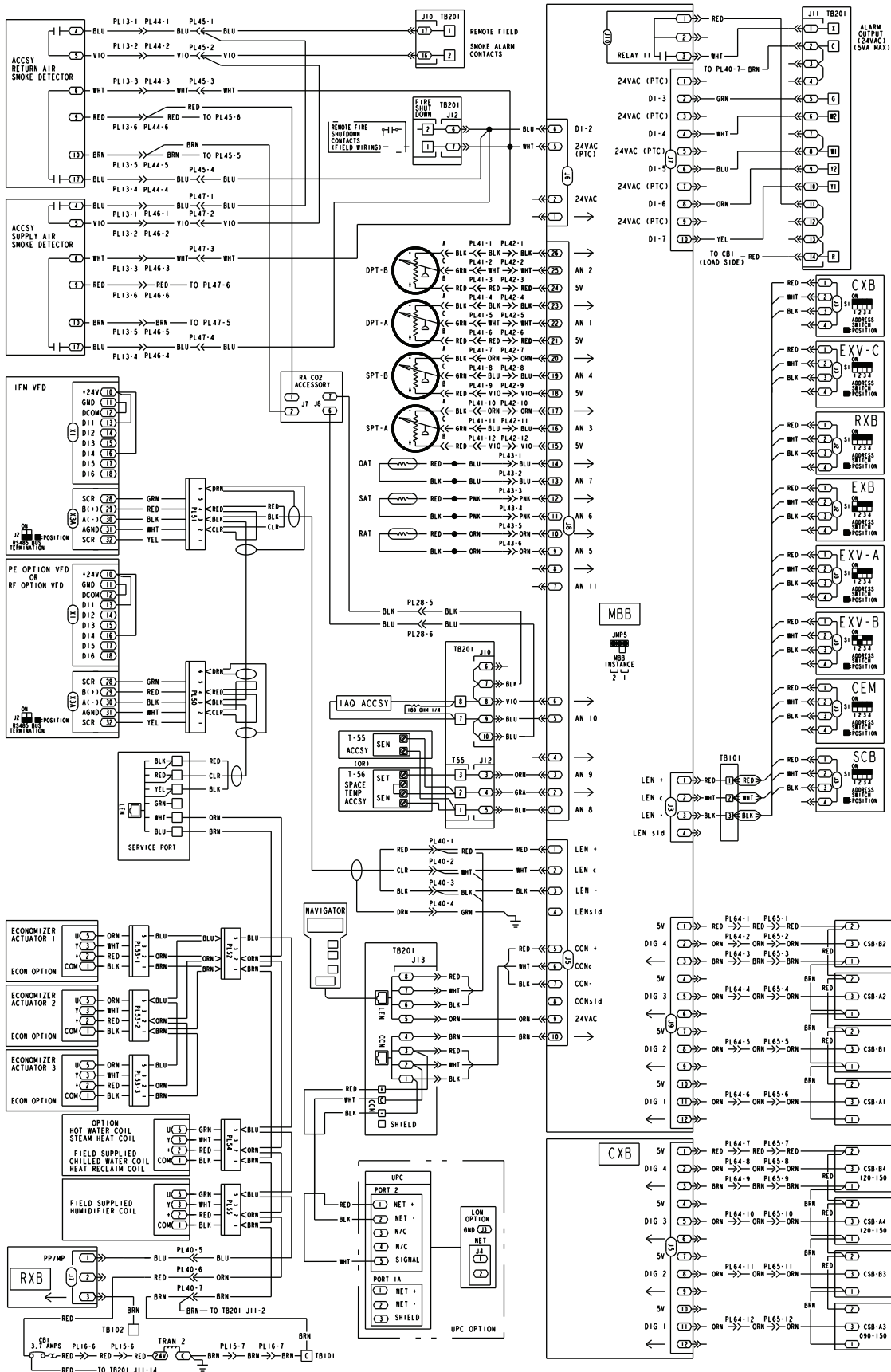

CONTROL SECTION — 48/50N UNITS (cont)

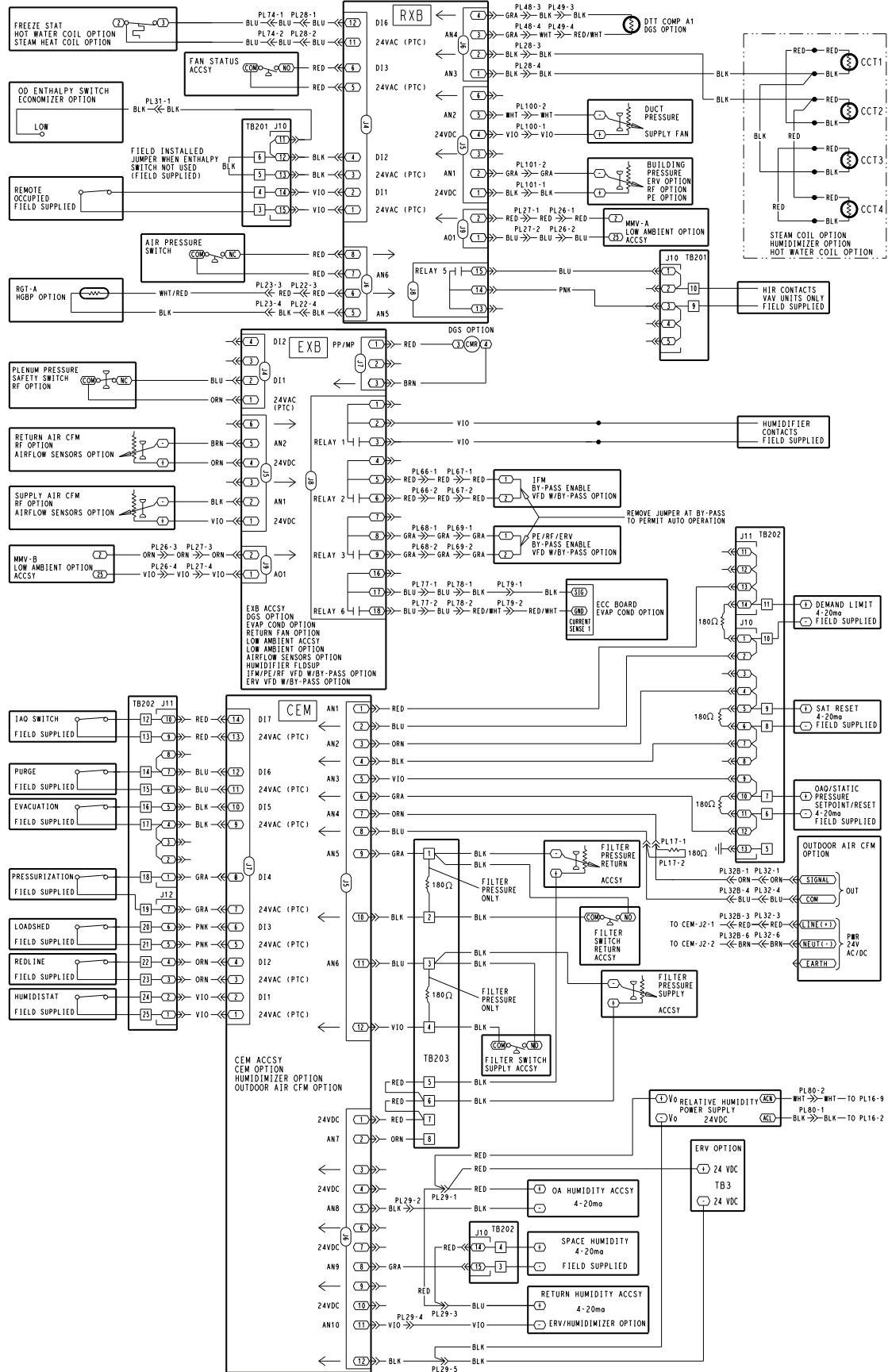

CONTROL SECTION — 48/50N UNITS (cont)

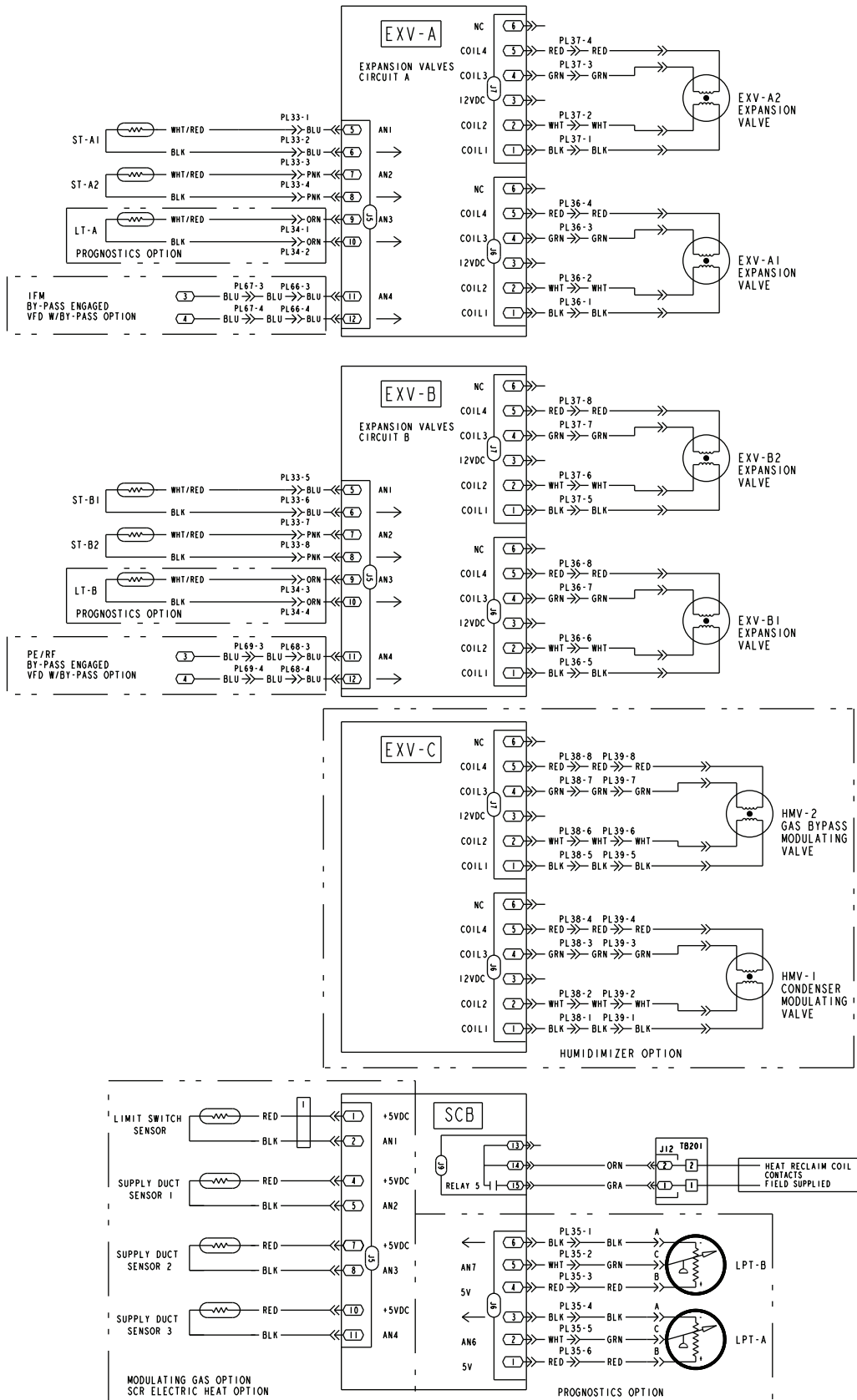

MODULATING GAS HEAT SCHEMATIC

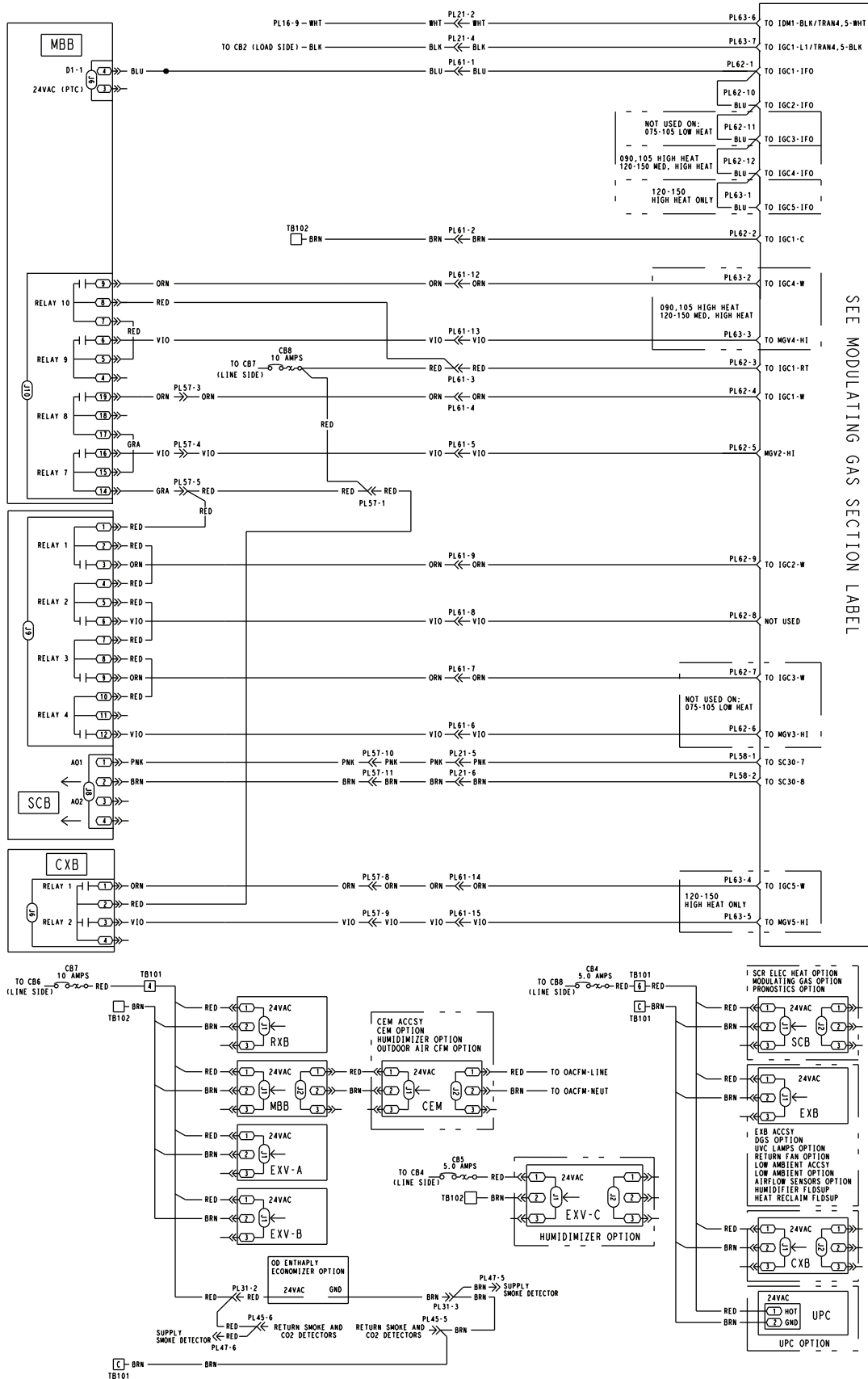

STANDARD GAS HEAT SCHEMATIC

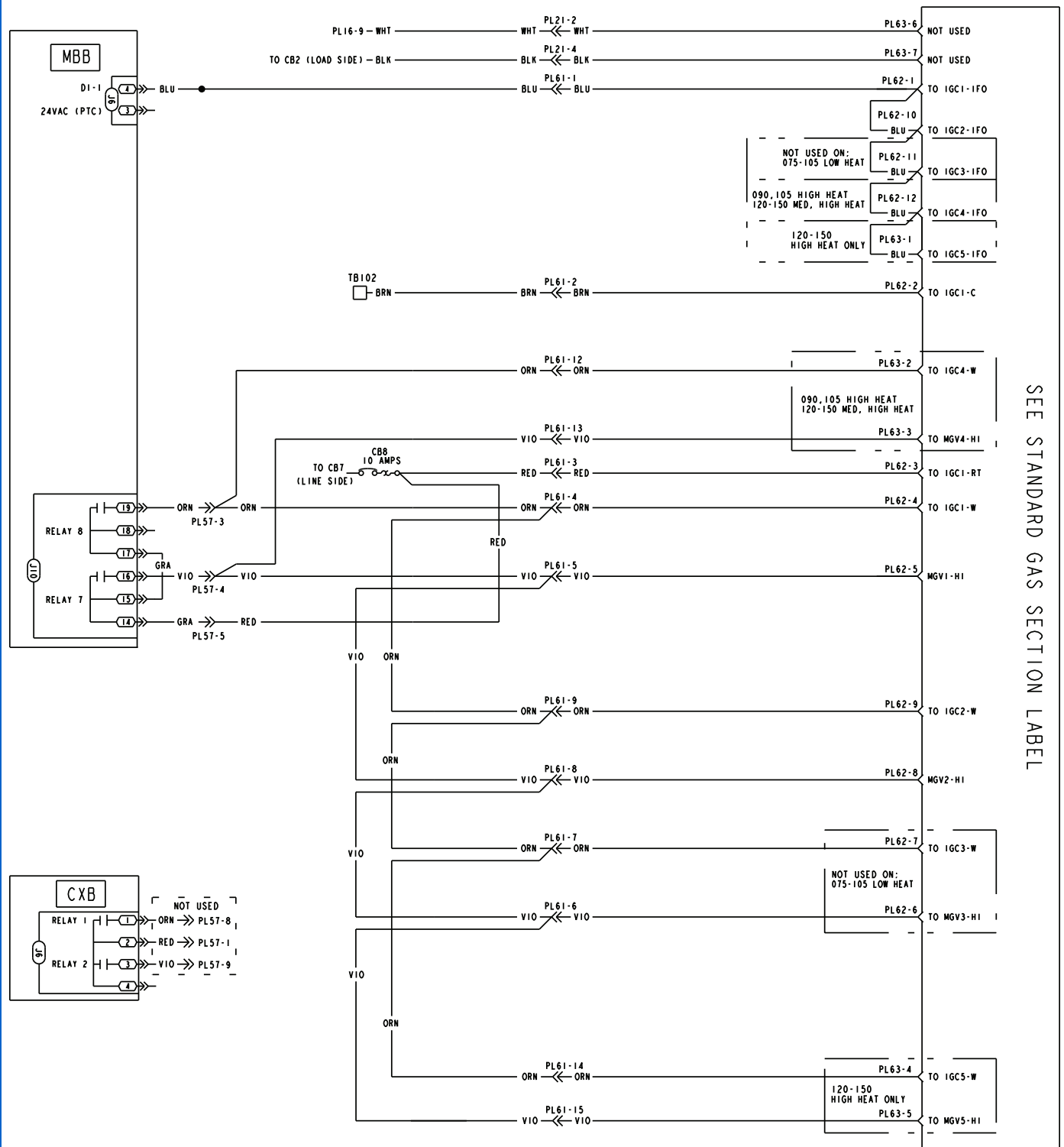

SEE STANDARD GAS SECTION LABEL

Typical wiring schematics (cont)



ELECTRIC HEAT SCHEMATIC

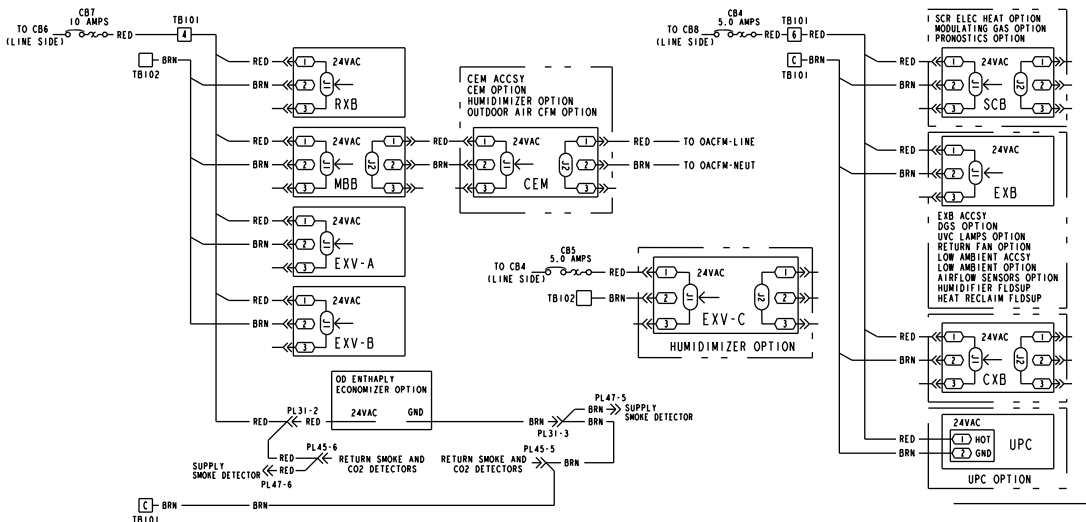
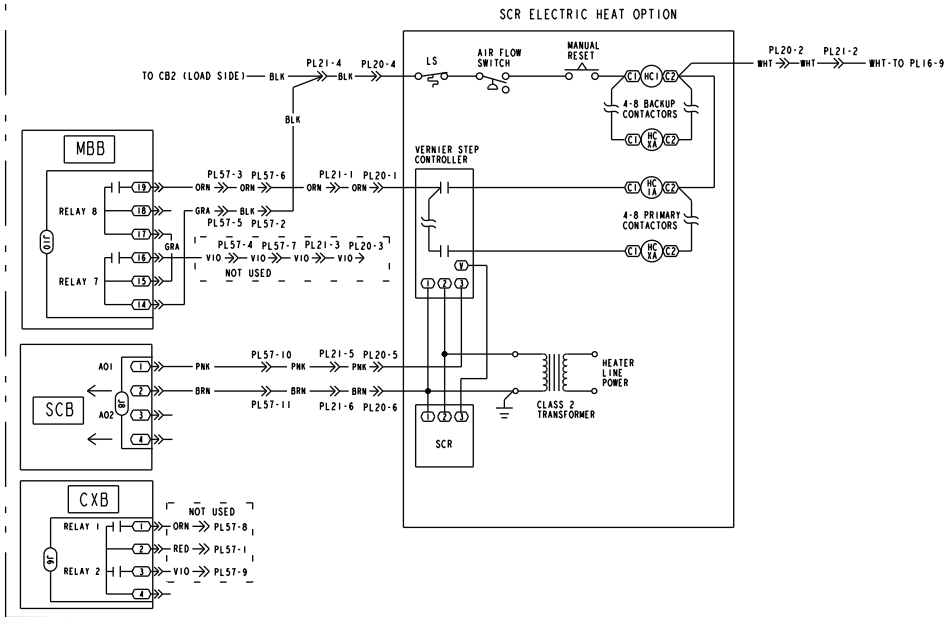
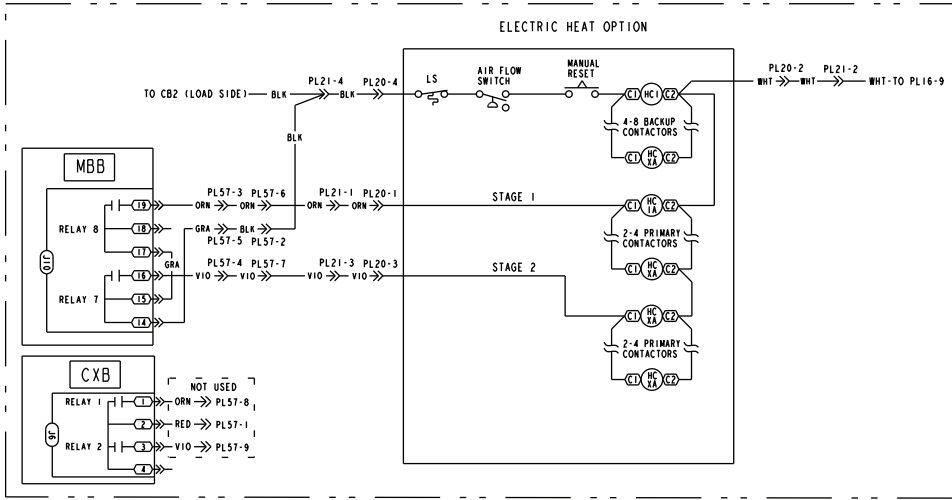

Typical wiring schematics (cont)



460-V, 24-V CONTROL SCHEMATIC

NOTES:
1. FOR UNITS WITH LOW AMBIENT OPTION/ACCST:

- 075-150 STD-EFF OFC1 IS REPLACED WITH MMR-A
- 075-130 HI-EFF OFC1 IS REPLACED WITH MMR-A
- 075 HI-EFF OFC2 IS REPLACED WITH MMR-B
- 075-120 STD-EFF OFC2 IS REPLACED WITH MMR-B
- 090-130 HI-EFF OFC3 IS REPLACED WITH MMR-B
- 130-150 STD-EFF OFC3 IS REPLACED WITH MMR-B
- 2. JUMPER PLUG REQUIRED WHEN MP NOT USED.

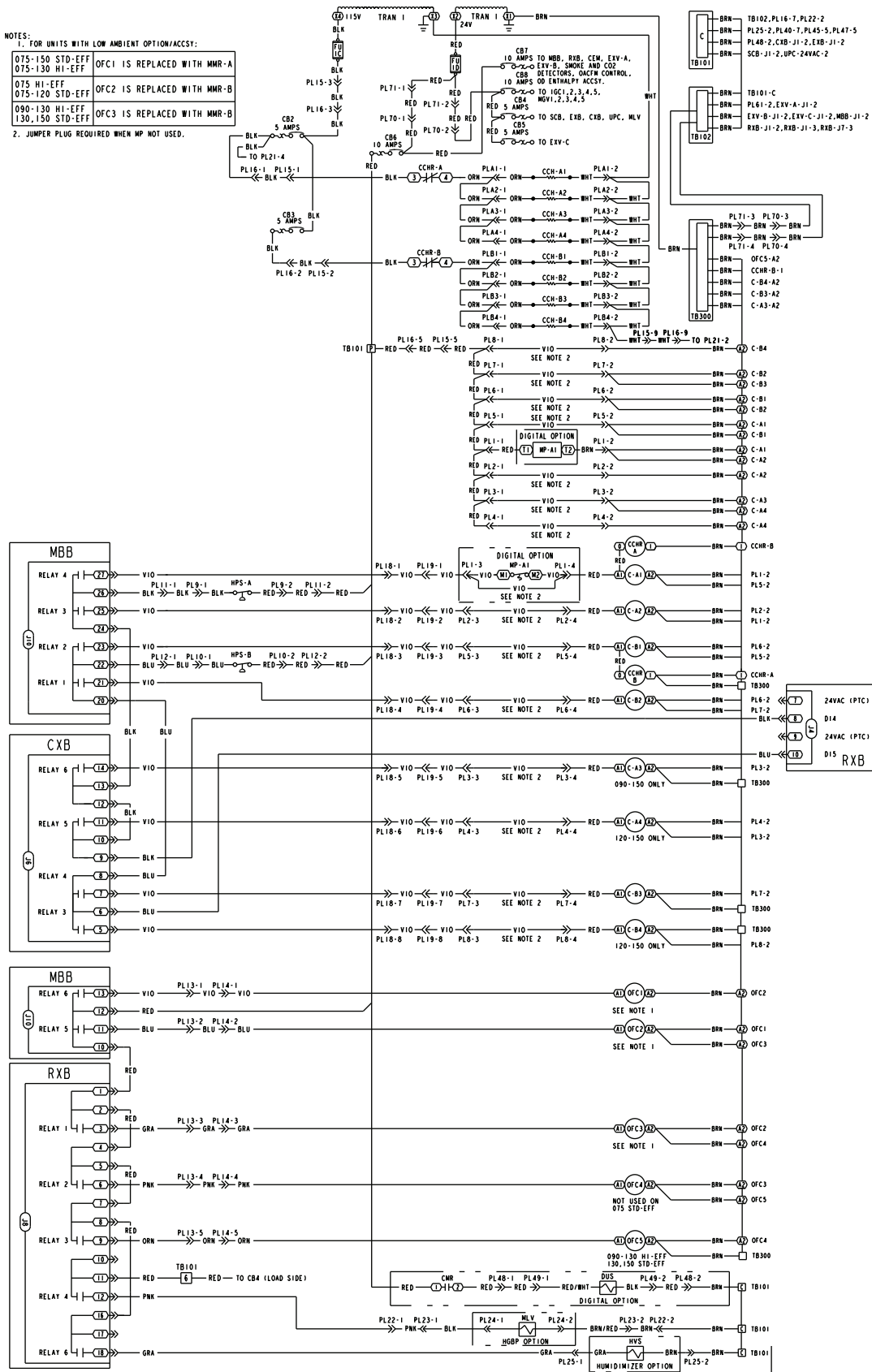

575-V, 24-V CONTROL SCHEMATIC

NOTES:

- MP-A3 NOT USED ON 075 UNIT
MP-A4 NOT USED ON 075, 090 UNITS
MP-B1 NOT USED ON 075 UNIT
MP-B2 NOT USED ON 075 UNIT
MP-B3 NOT USED ON 075 UNIT
MP-B4 NOT USED ON 075, 090 UNITS

2. FOR UNITS WITH LOW AMBIENT OPTION/ACCSY:

075-150 STD-EFF	075-130 HI-EFF	OFC1 IS REPLACED WITH MMR-A
075 HI-EFF	075-120 STD-EFF	OFC2 IS REPLACED WITH MMR-B
090-130 HI-EFF	130, 150 STD-EFF	OFC3 IS REPLACED WITH MMR-B

3. JUMPER PLUG REQUIRED WHEN MP NOT USED.

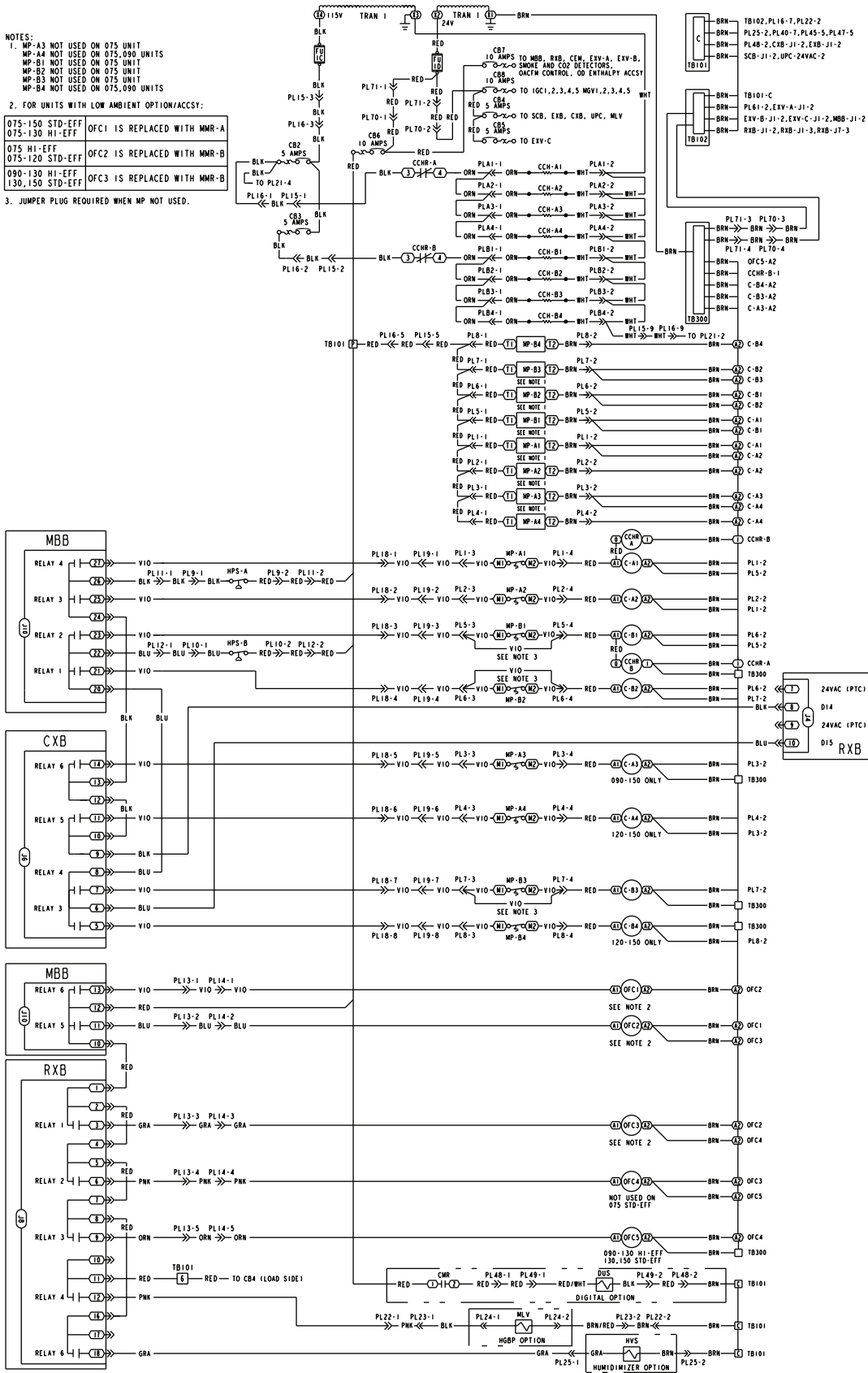

STANDARD GAS HEAT, 2 MODULE SCHEMATIC

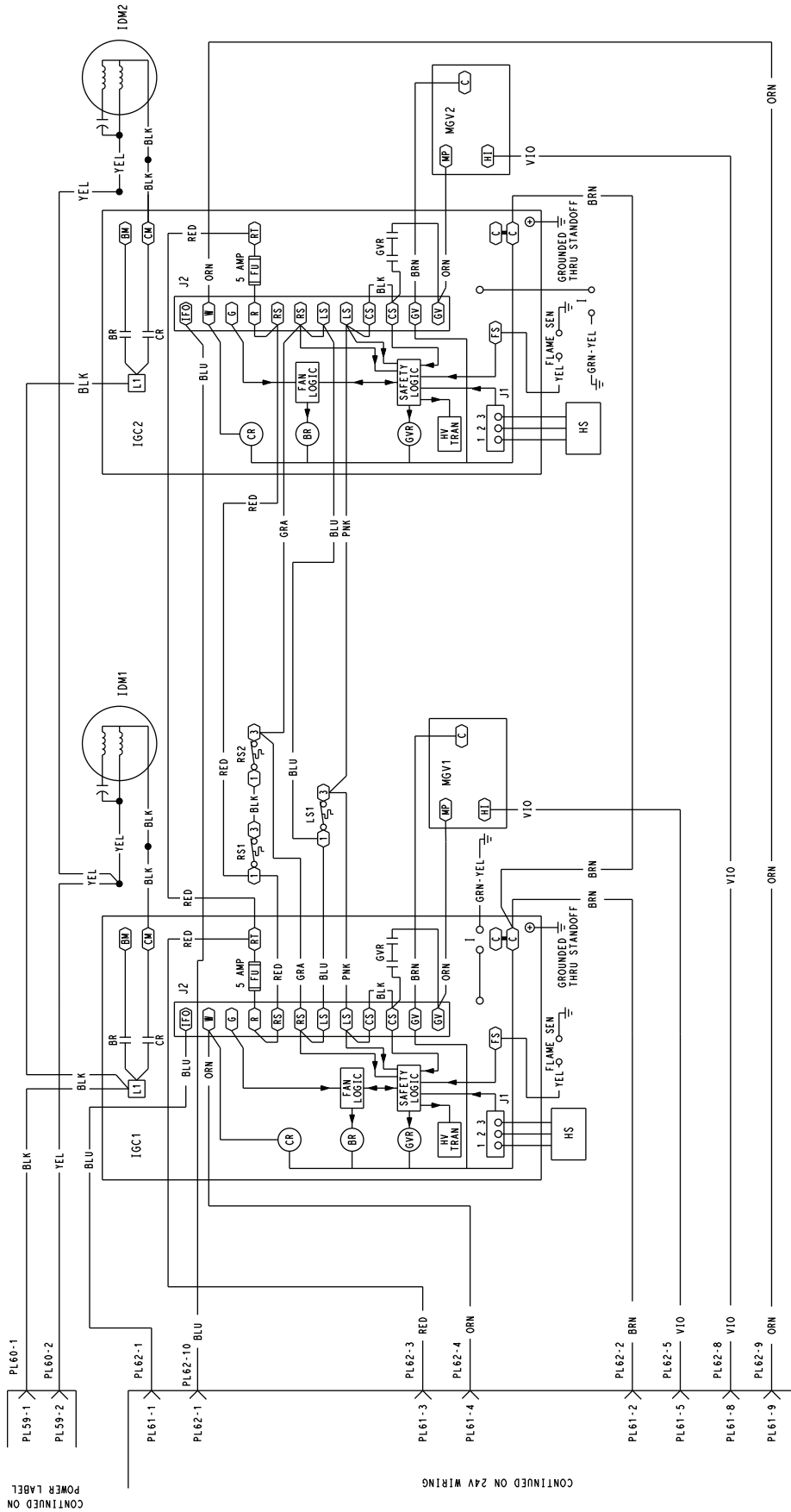

CONTINUED ON
POWER LABEL

CONTINUED ON 24V WIRING

STANDARD GAS HEAT, 3 MODULE SCHEMATIC

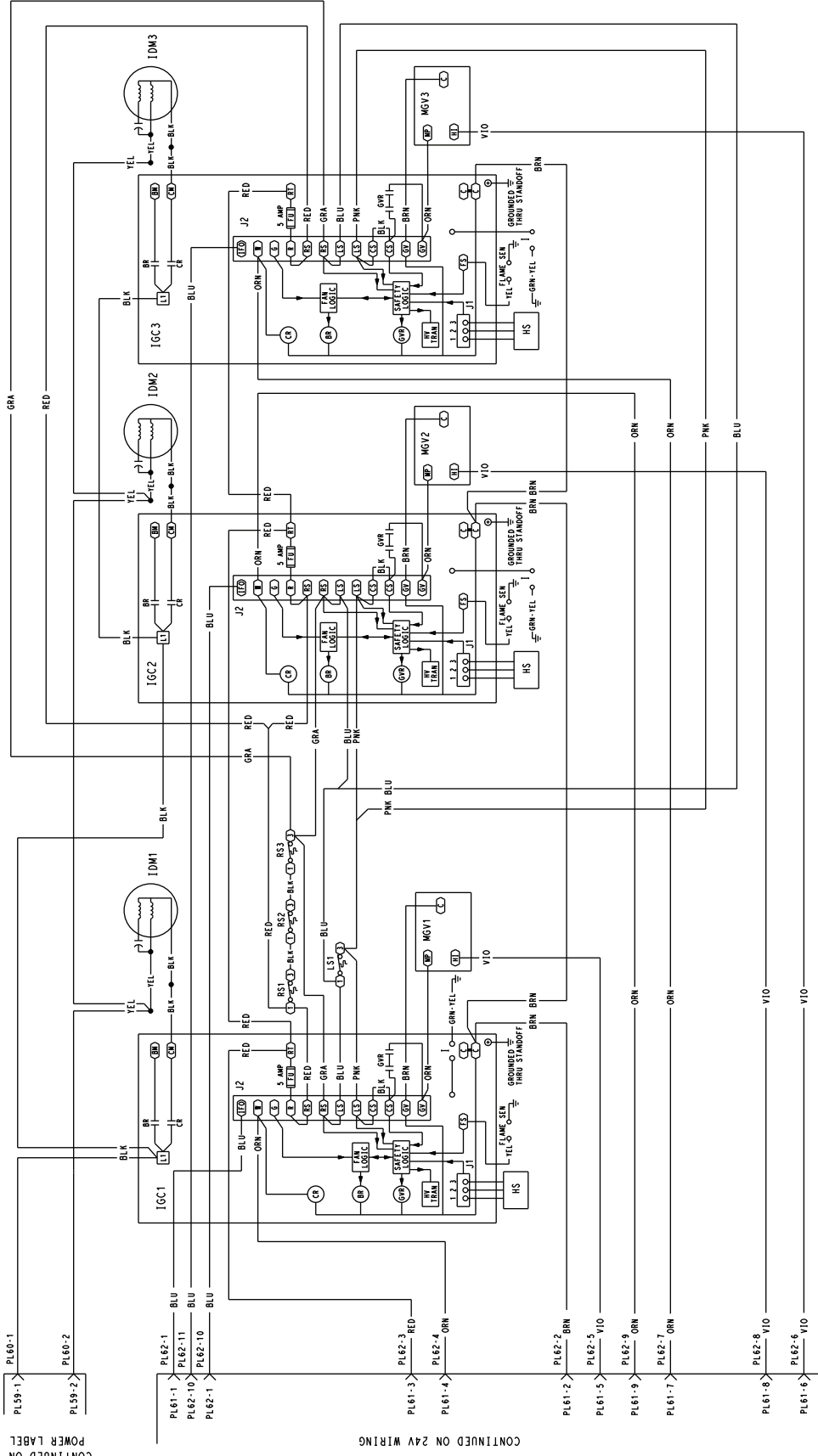

CONTINUED ON
POWER LABEL

CONTINUED ON 24V WIRING

STANDARD GAS HEAT, 5 MODULE SCHEMATIC

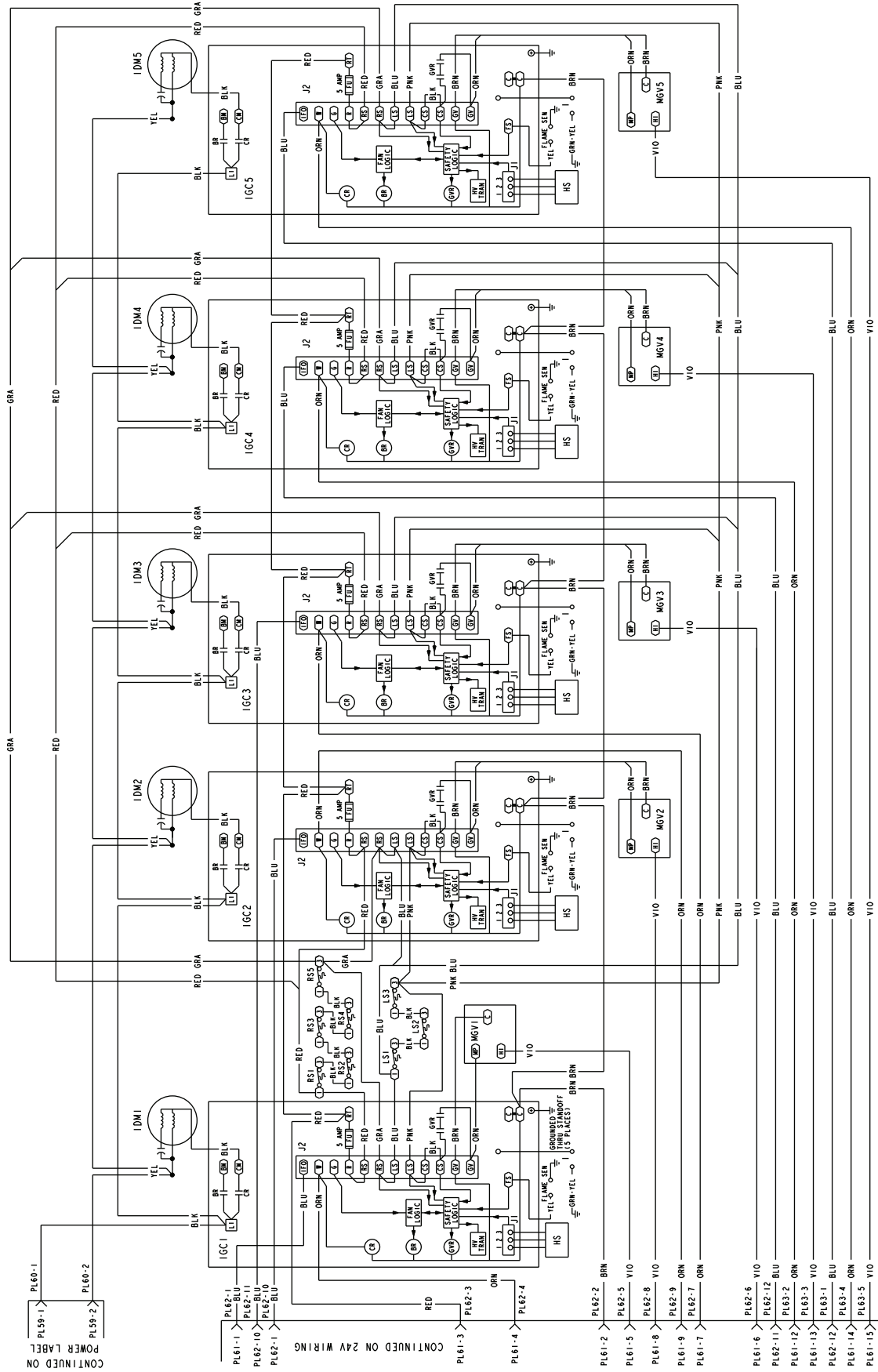

LEGEND FOR TYPICAL CONTROL WIRING SCHEMATICS

ACCSY — Accessory
ACCY — Accessory
AF — Air Foil
AN — Analog
AO — Analog Output
BR — Blower Relay
C — Compressor Contactor
CB — Compressor Circuit Breaker
CCB — Control Circuit Breaker
CCH — Crankcase Heater
CCHR — Crankcase Heater Relay
CCN — Carrier Comfort Network®
CCT — Cooling Coil Thermistor
CEM — Controls Expansion Module
CMR — Compressor Modulation Relay
COMP — Compressor
CR — Control Relay
CSB — Current Sensor Board
CXB — Compressor Expansion Board
DGS — Digital Scroll Compressor
DI — Digital Input
DPT — Discharge Pressure Transducer
DTT — Discharge Temperature Thermistor
DUS — Digital Unloader Solenoid
ECON — Economizer
EQUIP — Equipment
EVAP — Evaporator
EXB — Economizer Control Board
EXV — Expansion Valve Control Board
FU — Fuse
GND — Ground
GVR — Gas Valve Relay

HC — Heater Contactor
HGBP — Hot Gas Bypass
HIR — Heat Interlock Relay
HMV — Humidi-MiZer® Modulating Valve
HPS — High-Pressure Switch
HS — Hall Effect Switch
HVS — Humidi-MiZer Valve Solenoid
IAQ — Indoor Air Quality
IDM — Induced Draft Motor
IFCB — Indoor Fan Circuit Breaker
IFM — Indoor Fan Motor
IGC — Integrated Gas Controller
LEN — Local Equipment Network
LPT — Liquid Pressure Transducer
LS — Limit Switch
LT — Liquid Temperature
MBB — Main Base Board
MGV — Main Gas Valve
MLV — Minimum Load Valve
MM — Motormaster®
MP — Modular Motor Protector
OA — Outdoor Air
OAQ — Outdoor Air Quality
OD — Outdoor
OFC — Outdoor Fan Contactor
OFM — Outdoor Fan Motor
PE — Power Exhaust
PECB — Power Exhaust Circuit Breaker
PEM — Power Exhaust Motor
PL — Plug Assembly
PP — Plenum Pressure
PTC — Positive Temperature Coefficient Power Reference

RA — Return Air
RF — Return Fan
RFCB — Return Fan Circuit Breaker
RFM — Return Fan Motor
RGT — Return Gas Thermistor
RS — Rollout Switch
RXB — Rooftop Control Board
SAT — Supply Air Thermistor
SCB — Staged Gas Control Board
SCCR — Short Circuit Current Rating
SCR — Silicon-Controlled Rectifier
SPT — Suction Pressure Transducer
ST — Suction Temperature
TB — Terminal Block
TRAN — Transformer
UPC — Unitary Protocol Converter
UVC — Ultraviolet
VAV — Variable Air Volume
VFD — Variable Frequency Drive



Terminal Block



Terminal (Unmarked)



Terminal (Marked)



Splice



Factory Wiring



Field Wiring



To indicate common potential only, not to represent wiring.



To indicate FIOP or Accessory

Packaged Rooftop Cooling Unit with Gas Heat and *ComfortLink* Controls

HVAC Guide Specifications — Section 48N2,N3,N4,N5,N6,N7,N8,N9

Size Range: 75 to 150 Tons, Nominal

Carrier Model Number:

48N2 (Vertical Supply/Return, Constant Volume [CV] Application, Staged Air Volume [SAV™])

48N3 (Vertical Supply/Return, Variable Air Volume [VAV] Application)

48N4 (Horizontal Supply/Return, Constant Volume Application, Staged Air Volume)

48N5 (Horizontal Supply/Return, Variable Air Volume Application)

48N6 (Vertical Supply/Horizontal Return, Constant Volume Application, Staged Air Volume)

48N7 (Vertical Supply/Horizontal Return, Variable Air Volume Application)

48N8 (Horizontal Supply/Vertical Return, Constant Volume Application, Staged Air Volume)

48N9 (Horizontal Supply/Vertical Return, Variable Air Volume Application)

Part 1 — General

1.01 SYSTEM DESCRIPTION

Outdoor, roof-curb mounted, electronically controlled heating and cooling unit utilizing hermetic scroll compressors with crankcase heaters for cooling duty and gas combustion for heating duty. Units shall supply air vertically or horizontally and return air vertically or horizontally as shown on the contract drawings.

1.02 QUALITY ASSURANCE

- A. The management system governing the manufacture of this product is ISO (International Organization for Standardization) 9001:2015 certified.
- B. Unit shall be rated in accordance with AHRI (Air-Conditioning, Heating, and Refrigeration Institute) Standard 340/360, latest edition.
- C. Unit shall be designed to conform to ANSI (American National Standards Institute)/ASHRAE (American Society of Heating, Refrigeration and Air-Conditioning Engineers) 15 (latest edition), ASHRAE 62, and UL Standard 1995.
- D. Unit shall be listed by ETL and ETL, Canada, as a total package.
- E. Unit shall be designed to conform to ANSI Standard Z21.47 (U.S.A.)/CSA Standard 2.3 (Canada), Gas-Fired Central Furnaces.
- F. Roof curb shall be designed to NRCA (National Roofing Contractors Association) criteria per Guideline B-1986.
- G. Insulation and adhesive shall meet NFPA (National Fire Protection Association) 90A requirements for flame spread and smoke generation.

1.03 DELIVERY, STORAGE, AND HANDLING

- A. All units shall be completely shrink-wrapped from the factory for protection during shipment. Tarping of units is unacceptable.
- B. Inspect for transportation damage and store in clean dry place and protect from weather and construction traffic. Handle carefully to avoid damage to components, enclosures, and finish.

Part 2 — Products

2.01 EQUIPMENT

- A. Factory-assembled, single-piece heating and cooling unit. Contained within the unit enclosure shall be all factory wiring, piping, refrigerant charge (R-410A), operating oil charge, dual refrigerant circuits, micro-processor-based control system and associated hardware, and all special features required prior to field start-up.
- B. Unit Cabinet:
 1. Unit shall be double-wall construction with insulation sealed between the inner and outer panels. Panel assemblies shall not carry an R-value of less than 10. The panels shall be galvanized steel (designated G60 per ASTM [American Society for Testing and Materials] Standard A653 - minimum coating weight of 0.6 oz of zinc per square foot), bonderized and primer-coated on both sides and coated with a baked polyester thermosetting powder coating finish on the outer surface.
 2. Unit casing shall be capable of withstanding ASTM Standard B117 500-hour salt spray test.
 3. Casing shall be watertight at -7 in. wg of internal pressure when tested per the UL 1995 rain test requirements. Leakage rate shall be tested and documented on a routine basis on random production units.
 4. Sides shall have person-size hinged access doors for easy access to the control box and other areas requiring servicing. Each door shall seal against a rubber gasket to prevent air and water leakage. Access doors shall be one piece, double-wall construction with insulation sealed between the inner and outer panels. Panel assemblies shall not carry an R-value of less than 10. Access doors shall be equipped with tiebacks.
 5. Side panels shall be easily removable for access to unit and shall seal against a full perimeter automotive style gasket to ensure a tight seal.
 6. Interior cabinet surfaces within heat exchanger section shall be lined with sheet metal on all surfaces, insulated on the side opposite the airstream.
 7. Insulation shall be applied by means of adhesion using a water reducible adhesive sprayed onto interior surface. Adhesive shall maintain a satisfactory adhesion and cohesion within the temperature range of -20 to 180°F and have

excellent resistance to water and water vapor when cured.

8. Unit shall contain a double sloped drain pan, to prevent standing water from accumulating. Pan shall be fabricated of stainless steel. Unit shall contain a factory-installed nonferrous main condensate drain connection.
 9. Top cover of airside section to be sloped to prevent standing water.
 10. Units shall be equipped with lifting lugs to facilitate overhead rigging. Lifting lugs shall also be suitable as tie down points.
- C. Compressors:
1. Fully hermetic scroll type compressors with overload protection and short cycle protection with minimum on and off timers.
 2. Factory rubber-in-shear mounted for vibration isolation.
 3. Reverse rotation protection capability.
 4. Crankcase heaters shall only be activated during compressor off mode.
- D. Coils:
1. Evaporator Coil:
 - a. Intertwined circuiting constructed of aluminum fins mechanically bonded to seamless copper tubes.
 - b. Full-face active type during full and part load conditions.
 - c. Coils shall be leak tested at 150 psig and pressure tested at 650 psig.
 2. Condenser Coils:
 - a. Condenser coils shall be microchannel design. The coils shall have a series of flat tubes containing a series of multiple, parallel flow microchannels layered between the refrigerant manifolds. Microchannel coils shall consist of a two-pass arrangement. Coil construction shall consist of aluminum alloys for the fins, tubes and manifolds.
 - b. Air-cooled condenser coils shall be leak tested at 150 psig and pressure tested at 650 psig.
- E. Fans:
1. Supply Fan:
 - a. Unit shall have only one fan wheel, scroll, and motor.
 - b. Fan scroll, wheel, shaft, bearings, drive components and motor shall be mounted on a formed steel assembly which shall be isolated from the unit outer casing with factory-installed 2-in. deflection spring isolators and vibration-absorbent fan discharge seal.
 - c. Fan shall be double-width, double-inlet, centrifugal belt driven airfoil type with single outlet discharge.
 - d. Fan wheel shall be designed for continuous operation at the maximum rated fan speed and motor horsepower.
 - e. Fan wheel and shaft shall be selected to operate at 25% below the first critical speed and shall be statically and dynamically balanced as an assembly.
 - f. Fan shaft shall be solid steel, turned, ground and polished, and coated with rust preventative oil.
 - g. Fan shaft bearings shall be self-aligning, pillow-block, re-greasable ball or roller-type selected for a minimum average life of 200,000 hours at design operating conditions in accordance with ANSI B3.15.
 - h. A single motor shall be mounted within the fan section casing on slide rails equipped with adjusting screws. Motor shall be mounted on a horizontal flat surface and shall not be supported by the fan or its structural members. Motor speed shall be controlled by a variable frequency drive.
 - i. Fan drive shall be constant-speed fixed-pitch. All drives shall be factory-mounted, with belts aligned and tensioned.
 - j. Shall include a high static pressure safety switch installed into the supply air plenum.
 - k. A high-static supply fan option shall be available.
2. Condenser Fans:
 - a. Direct-driven propeller type.
 - b. Discharge air vertically upward.
 - c. Protected by PVC-coated steel wire safety guards.
 - d. Statically and dynamically balanced.
 - e. Three-phase, totally enclosed motors.
- F. Variable Frequency Drive:
- All supply fan (and power exhaust fan and/or return fan motors, if equipped) shall be equipped with variable frequency drive (VFD) inverter. The VFD shall be provided with a metal enclosure and shall be factory-mounted, wired, and tested. The variable speed drive shall include the following features:
1. Full digital control with direct control from the unit *ComfortLink* controls.
 2. Insulated gate bi-polar transistors (IGBT) used to produce the output pulse width modulated (PWM) waveform, allowing for quiet motor operation.
 3. Inverters capable of operation at a frequency of 8 kHz so no acoustic noise shall be produced by the motor.
 4. VFDs shall include EMI/RFI (electromagnetic / radio frequency interference) filters.
 5. Digital display keypad module, mounted on the VFD enclosure.

6. Local/Remote and Manual/Auto function keys on the keypad.
 7. UL-listed electronic overload protection.
 8. Critical frequency avoidance.
 9. Self diagnostics.
 10. On-board storage of unit manufacturer's customer user settings, retrievable from the keypad.
 11. RS485 communications capability (accessory card source required).
 12. Internal thermal overload protection.
 13. 5% swinging (non-linear) chokes for harmonic reduction and improved power factor.
 14. All printed circuit boards shall be conformal coated.
 15. Shall, through ABB, qualify for a 24-month warranty from date of commissioning or 30 months from date of sale, whichever comes first.
- G. Outdoor-Air Hood Assembly:
Factory-installed motorized outdoor-air damper shall allow intake of up to 100% nominal airflow (on units not equipped with optional economizer).
- H. Heating Section:
1. Induced-draft combustion type with energy saving direct spark ignition systems and redundant main gas valves.
 2. The heat exchanger shall be of the tubular section type constructed of a minimum of 20-gage steel coated with a nominal 1.4 mil aluminum-silicone alloy for corrosion resistance.
 3. Burners shall be of the in-shot type constructed of aluminized steel.
 4. Induced Draft Fans:
 - a. Direct-driven, single inlet, forward-curved centrifugal type.
 - b. Statically and dynamically balanced.
 - c. Made from steel with a corrosion-resistant finish.
 5. High-corrosion areas such as flue gas collection and exhaust areas shall be lined with corrosion-resistant material.
 6. All gas piping shall enter the unit cabinet at a single location.
- I. Refrigerant Components:
Unit shall be equipped with dual refrigerant circuits, each containing:
1. Filter drier.
 2. Moisture indicating sight glass.
 3. Two electronic expansion valves.
 4. Fusible plug.
- J. Filter Section:
1. Mixed air filter section shall consist of 2-in. thick, MERV (Minimum Efficiency Reporting Value) 7 disposable fiberglass filters of commercially available sizes. Optional pleated, bag and cartridge filters shall be available. (See special features section.)
 2. Factory 2-in. filter track shall allow easy field conversion to accept 4-in. thick, disposable fiberglass filters of commercially available sizes.
 3. Optional final filters with pre-filters shall be available. (See special features section.)
- K. Controls, Safeties, and Diagnostics:
1. Controls:
 - a. Control shall be accomplished through the use of a factory-installed, microprocessor-based control system and associated electronic and electrical hardware. Control system shall determine control sequences through monitoring the following operational variables:
 - 1) Day and Time.
 - 2) Schedule (Unoccupied/Occupied).
 - 3) Set points (Unoccupied/Occupied, Economizer, Duct Pressure, others).
 - 4) Space temperature.
 - 5) Outdoor-air temperature.
 - 6) Unit supply-air temperature.
 - 7) Unit return-air temperature.
 - 8) Supply-air fan status.
 - 9) Economizer position.
 - 10) Compressor suction and discharge pressure.
 - 11) Navigator™ display.
 - 12) Accessory and/or field-supplied sensors, function switches and/or signals.
 - b. Controls shall be capable of performing the following functions:
 - 1) Capacity control based on supply-air temperature and compensated by rate of change of return-air temperature (VAV) or room temperature (CV). Capacity control shall be accomplished through the use of compressor staging or optional variable output compressors.
 - 2) Perform a quick test to check the status of all input and output signals to the control system using the Navigator™ display.
 - 3) Control of integrated economizer operation, based on unit supply-air temperature.
 - 4) Supply fan volume control shall control output from a variable frequency drive to maintain duct static pressure at user-configured set point (VAV). Static pressure reset in conjunction with Carrier communicating terminals to reduce supply fan power requirements. Control system calculates the amount of supply static pressure reduction necessary to cause the most open damper in the system to open

- more than the minimum value (60%) but not more than the maximum value (90% or negligible static pressure drop).
- 5) Heating control shall provide space temperature control for unoccupied period heating, morning warm-up sequence and occupied period heating (when configured). Leaving air temperature control shall be provided when unit is equipped with modulating gas heat option.
 - 6) Adaptive optimal start shall determine the time unit will commence cooling (or heating or heating for morning warm-up) during the unoccupied mode to ensure occupied space reaches the set point in time for occupied mode.
 - 7) Adaptive optimal stop shall turn off the compressors a preset amount of time before the end of the occupied mode to conserve energy (CV only).
 - 8) Alerts and Alarms: Control shall continuously monitor all sensor inputs and control outputs to ensure safe and proper system operation. Alerts shall be generated whenever sensor conditions have gone outside criteria for acceptability. Alarms shall be initiated when unit control detects that a sensor input value is outside its valid range (indicating a defective device or connection that prevents full unit operation) or that an output has not functioned as expected or that a safety device has tripped. Current alarms shall be maintained in STATUS function; up to 9 (current or reset) shall be stored in HISTORY function for recall.
 - 9) Timed override function shall permit a system in unoccupied mode to be returned to occupied mode for a user-configured period of 1, 2, 3 or 4 hours by pressing the override button on the front of the space temperature sensor.
 - 10) Nighttime Free Cooling (NTFC) shall start the supply fan and open the economizer on cool nights to precool the building structure mass using only outdoor air. Function shall be restricted to operation above a user-configured low lockout temperature set point.
 - 11) Modulating power exhaust control shall utilize a VFD to modulate capacity of exhaust fan system. Capacity of exhaust air shall be modulated in response to building static pressure at user-configured set point. Power exhaust fan operation shall be interlocked with supply fan operation.
 - 12) Return fan control (on optional return fan equipped units only) shall measure supply fan cfm and shall utilize a VFD to modulate the return fan to maintain constant cfm differential between supply and return fan. Return fan operation shall be interlocked with supply fan operation. Capacity of exhaust air shall be modulated in response to building static pressure at user-configured set point.
 - 13) Smoke control functions: Control shall initiate any of four separate smoke control functions in response to closure of field switches. Functions shall include: Pressurization, Evacuation, Smoke Purge, and Fire Shutdown. Should two or more switches be closed simultaneously, Fire Shutdown shall be initiated.
 - 14) Support demand controlled ventilation through a reset of the economizer's minimum position. This reset based on differential CO₂ ppm (outdoor and indoor) can be chosen as linear or as fast or slow-acting exponential curves.
 - 15) Indoor air quality (IAQ) mode shall admit fresh outdoor air into the space whenever space air quality sensors detect unsuitable space conditions, by overriding economizer minimum damper position. IAQ shall be permitted only during occupied periods, unless configured to be allowed during unoccupied periods also.
 - 16) Provide control for reheat via auxiliary heating coil or gas heat during ventilation.
 - 17) IAQ pre-occupancy purge function shall provide complete exchange of indoor air with fresh air during unoccupied periods, when outdoor conditions permit. Function shall energize supply fan and open economizer two hours before next occupied period; duration of purge shall be user-configured (5 to 60 minutes).
 - 18) Outdoor Air Control (OAC) function shall maintain a minimum quantity of outdoor airflow into an occupied space. OAC mode shall be available only during an occupied period. Outdoor airflow shall be monitored by an airflow station and transducer. Economizer maximum damper opening position during OAC mode shall be user-configured.
 - 19) Dehumidification and Reheat: Dehumidification function shall override comfort condition set points to deliver cooler air into the space and satisfy a user-configured humidity set point at the space or return air humidity sensor. Reheat function shall energize an auxiliary heating device should dehumidification operation result in cooling of the space down to the occupied heating set point.

- 20) Supply Air Temperature Set Point Reset: Control shall automatically reset the unit supply air temperature set point on VAV models from either space temperature or return-air temperature, at user-configured rate and limit. Control shall also reset supply air temperature set point via external 2 to 10 vdc signal representing 0° to 20°F range of reset. Control shall respond to higher of either reset if both are active.
 - 21) Space Temperature Offset function shall permit occupants to adjust space temperature set point by $\pm 5^\circ\text{F}$ using T-56 space sensor (equipped with sliding scale adjuster).
 - 22) Lead-lag function shall distribute starts between the two refrigeration circuits in an effort to equalize the running time on the two circuits.
 - 23) Condenser-fan cycling control shall maintain correct head pressure down to 32°F.
 - 24) Refrigeration system pressures shall be monitored via pressure transducers. Alarms for low pressure, high pressure will be permitted.
 - 25) Timed Discrete Output function shall control an external function or device via user-configured activity schedule. This schedule shall be separate and different from the unit's occupied/unoccupied time schedule.
 - 26) Humidifier control shall provide control for either LEN (local equipment network) communicating control valve or discrete-type output, to maintain space humidity conditions at user-configured set points.
 - 27) Two-step demand limit control (when used in conjunction with CEM [controls expansion module]).
 - 28) Display in Metric units: Display may be configured to display data in Metric or English (Imperial) units of measure.
2. Safeties:

Unit components shall be equipped with the following protections:

 - a. Compressors:
 - 1) Overcurrent using calibrated circuit breakers (shuts down individual compressor).
 - 2) Crankcase heaters.
 - 3) High-pressure switch (shuts down individual circuit, automatic reset type).
 - 4) Low-pressure monitoring (shuts down individual circuit, automatic reset type).
 - b. Check filter switch.
 - c. Belt-Drive Fan Motors:

Overcurrent protection manual reset circuit breakers.
 - d. Supply Fan and Return Fan (when equipped):

High static pressure safety switch installed into the return air plenum.
 - e. Heating Section:
 - 1) Redundant gas valves.
 - 2) Flame proving controls.
 - 3) Induced-draft fan motor speed sensor.
 - 4) High-temperature limit switch.
 - 5) Flame rollout switch.
 3. Diagnostics and Prognostics:
 - a. The display shall be capable of indicating a safety lockout condition (alarm).
 - b. The display shall also be capable of indicating an alert condition which does not lock out the unit, but informs the system monitor of a condition which could be detrimental to either the unit or the comfort of the occupants if allowed to continue.
 - c. Test mode must also be capable of displaying outputs of microprocessor-controller and to verify operation of every thermistor, actuator motor, fan, and compressor before unit is started.
 4. Navigator™ Display Interface:

The Navigator display module shall be a portable hand-held display module with a minimum of 4 lines and 20 characters per line, of clear English language. Display menus shall provide clear language descriptions of all menu items, operating modes, configuration points and alarm diagnostics. Reference to factory codes shall not be accepted. An industrial grade coiled extension cord shall allow the display module to be moved around the chiller. Magnets shall hold the display module to any sheet metal panel to allow hands-free operation. Display module shall have NEMA (National Electrical Manufacturers Association) 4x housing suitable for use in outdoor environments. Display shall have back light and contrast adjustment for easy viewing in bright sunlight or night conditions. The display module shall have raised surface buttons with positive tactile response.
 - L. Operating Characteristics:
 1. Unit shall be capable of starting and running at 115°F (125°F for high-efficiency models) ambient outdoor temperature per maximum load criteria of AHRI Standard 340/360, latest edition.
 2. Unit shall be capable of mechanical cooling operation down to 32°F ambient outdoor temperature (-20°F with low ambient accessory).
 3. Provides multi-stage cooling capability.

4. Provides 2 stages of heating capability.

M. Motors:

1. Compressor motors shall be cooled by suction gas passing over motor windings.
2. Condenser-fan motors shall be 3-phase, totally enclosed type with permanently lubricated ball bearings and internal overtemperature protection.
3. Supply and exhaust fan motors shall be of the 3-phase, NEMA rated, open drip-proof (ODP), ball bearing type, with efficiencies per EISA (Energy Independence and Security Act) of 2007 (U.S.A.) requirements.

N. Electrical Requirements:

All unit power wiring shall enter unit cabinet at a single location.

O. Special Features:

1. Digital Compressor:

A digital compressor shall be available on the lead circuit for constant volume and variable air volume configurations. The *ComfortLink* control system shall be capable of unloading this compressor in an infinite number of steps from 100% of unit capacity down to 50% of compressor capacity.

2. Humidi-MiZer® Adaptive Dehumidification:

The Humidi-MiZer dehumidification system shall be factory installed with an e-coated reheat coil, and shall provide greater dehumidification of the occupied space by using two modes of dehumidification instead of the normal design cooling mode of the unit:

- a. Subcooling mode shall further sub-cool the hot liquid refrigerant leaving the condenser coil when both temperature and humidity in the space are not satisfied.
- b. Hot gas reheat mode shall mix a portion of the hot gas from the discharge of the compressor with the hot liquid refrigerant leaving the condenser coil to create a two-phase heat transfer in the system, resulting in a neutral leaving-air temperature.
- c. The system shall be equipped with modulating control valves to provide precise leaving air temperature control. On-off, cycling type control shall not be acceptable.

3. Condenser Coil Protective Coating - E-Coated Microchannel Coil:

E-coated aluminum microchannel coils shall have a flexible epoxy polymer coating uniformly applied to all coil external surface areas without material bridging between fins or louvers. Coating process shall ensure complete coil encapsulation, including all exposed fin edges. E-coat thickness of 0.8 to 1.2 mil with top coat having a uniform dry thickness from 1.0 to 2.0 mil on all external coil surface areas, including

fin edges, shall be provided. E-coated coils shall have superior hardness characteristics of 2H per ASTM D3363-00 and cross-hatch adhesion of 4B-5B per ASTM D3359-02. E-coated coils shall have superior impact resistance with no cracking, chipping, or peeling per NSF/ANSI 51-2002 Method 10.2.

4. Condenser Coil Louvered Guard:

Louvered panels complete with support retainers and fasteners shall be provided for protection of condenser coils.

5. Condenser Coil Grille Guard:

Welded wire grille complete with support retainers and fasteners shall be provided for protection of condenser coils.

6. Low Outdoor Sound:

Low sound fans for outdoor sound reduction shall be available as a factory-installed option for all units (except 90-ton high-efficiency, 105-ton, 120-ton high-efficiency, 130-ton high-efficiency, and 150-ton units).

7. Low Ambient Control:

- a. Control shall regulate fan motor speed in response to the saturated condensing temperature of the unit. The control shall be capable of operating with outdoor temperatures at -20°F.
- b. Motormaster® low ambient control shall be available as a factory-installed option or field-installed accessory for all units.

8. Service Valves:

Shall be equipped with ball type service valves in the suction, discharge, and liquid line for each circuit.

9. Replaceable Core Filter Drier:

Shall be equipped with a replaceable core filter drier with isolation valves in each liquid line.

10. Hot Gas Bypass:

Unit shall be factory-equipped with hot gas bypass valve and tubing to maintain capacity control at minimal cooling loads.

11. Evaporator Coil Options:

- a. Copper-fin coils shall be constructed of copper fins mechanically bonded to copper tubes and copper tube sheets. Galvanized steel tube sheets shall not be acceptable. A polymer strip shall prevent coil assembly from contacting the sheet metal coil pan to minimize potential for galvanic corrosion between coil and pan. All copper construction shall provide protection in moderate coastal environments.
- b. E-coated aluminum-fin coils shall have a flexible epoxy polymer coating uniformly applied to all coil surface areas without material bridging between fins. Coating process shall ensure complete coil encapsulation. Color

shall be high gloss black with gloss — 60 deg of 65 to 90% per ASTM D523-89. Uniform dry film thickness from 0.8 to 1.2 mil on all surface areas including fin edges. Superior hardness characteristics of 2H per ASTM D3363-92A and cross-hatch adhesion of 4B-5B per ASTM D3359-93. Impact resistance shall be up to 160 in./lb (ASTM D2794-93). Humidity and water immersion resistance shall be up to minimum 1000 and 250 hours respectively (ASTM D2247-92 and ASTM D870-92). Corrosion durability shall be confirmed through testing to be no less than 1000 hours salt spray per ASTM B117-90. Coil construction shall be aluminum fins mechanically bonded to copper tubes.

12. Motorized Outdoor Air Damper:

- a. Package consisting of dampers, actuator, and linkages in conjunction with control system to provide outdoor air.
- b. Dampers shall be an ultra low-leakage type with blade and edge seals. Dampers shall exhibit a maximum leakage rate of 4 cfm per square foot of area at 1 in. wg pressure differential when tested in accordance with AMCA Standard 500.
- c. Dampers shall function as intended after 100,000 cycles when tested in accordance with Section 8, UL standard 555S.

13. Ultra Low Leak Economizer:

Dry bulb, differential dry bulb temperature, enthalpy, or optional differential enthalpy controlled integrated type consisting of dampers, actuator, and linkages in conjunction with control system to provide primary cooling using outdoor air, enthalpy permitting, supplemented with mechanical cooling when necessary.

- a. Economizer shall meet the requirements of the California Energy Commission Title 24 economizer requirements.
- b. Dampers shall be a gear driven ultra low leakage type with blade and edge seals. Dampers shall exhibit a maximum leakage rate of 3 cfm per square foot of area at 1 in. wg pressure differential when tested in accordance with AMCA (Air Movement and Control Association) Standard 500.
- c. Dampers shall function as intended after 100,000 cycles when tested in accordance with Section 8, UL standard 555S.
- d. Actuator shall have a spring-return feature which shuts dampers upon a power interruption or unit shutdown. Actuators are capable of internal diagnostics.
- e. Equipped with a solid-state humidity sensor that is capable of sensing outdoor-air heat content (temperature and humidity) and

controlling economizer cut-in point at most economical level. The user can also configure dew point limiting.

14. Modulating Power Exhaust with VFD:

Package shall include a double-width, double-inlet centrifugal belt drive, forward-curved power exhaust fan with variable frequency drive control to maintain a field adjustable interior space pressure set point.

- a. Fan bearings shall be of the pillow block type with an average design life of 200,000 hours.
- b. Fans shall be statically and dynamically balanced.
- c. Installation:
 - 1) Site installation shall require supply and installation of building pressure (BP) sensing pick-up and tube to connect to BP transducer in unit.
 - 2) All other wiring and pressure tubing shall be factory-supplied and factory-installed.
- d. Bypass for the VFD shall be available as a factory-installed option.
- e. A high-static power exhaust option shall be available.

15. Return Fan/Building Pressure Control:

- a. Functions provided shall be:
 - 1) Airflow control for return duct path (dedicated to overcoming flow losses in return duct system).
 - 2) Modulate return airflow rate to track supply fan airflow rate and maintain a user set delta cfm between the supply and return airflow.
 - 3) Maintain building pressure by sensing building pressure and modulating fan motor speed.
- b. Option shall consist of following hardware:
 - 1) Plenum fan assembly, with welded steel airfoil blade fan.
 - 2) Spring isolation.
 - 3) Belt-drive fan system, fixed pitch for maximum belt life and reliability.
 - 4) Variable frequency drive (VFD) for return fan modulation control.
 - 5) Supply air cfm and return air cfm sensors to measure supply and return airflow.
 - 6) Exhaust damper with outlet hood.
 - 7) Building pressure transducer.
 - 8) High static pressure safety switch installed into the return air plenum.
- c. Installation:
 - 1) Site installation shall require supply and installation of building pressure (BP)

sensing pick-up and tube to connect to BP transducer in unit.

- 2) All other wiring and pressure tubing shall be factory-supplied and factory-installed.

- d. A high-static return fan option shall be available.

16. Extended Lube Lines:

Unit shall be equipped with extended lube lines to facilitate lubrication of fan bearings from one side of the unit.

17. Belt Guard:

Unit shall be equipped with belt guard on all belt-driven fans. The guard shall completely enclose the drive system and be removable for service.

18. Mixed Air Filters:

Unit shall be factory-equipped with:

- a. 4 in. MERV 8 pleated filters having the following characteristics: Efficiency of no less than 30% based on testing per ASHRAE Standard 52 and a minimum average arrestance of 95%.

- b. 4 in. MERV 14 pleated filters having the following characteristics: Efficiency of no less than 90% based on testing per ASHRAE Standard 52 and a minimum average arrestance of >98%.

- c. 12 in. MERV 14 bag filters having the following characteristics: Efficiency of no less than 90% based on testing per ASHRAE Standard 52 and a minimum average arrestance of >98%. This option shall be available with 2 in. or 4 in. pre-filters.

- d. 19 in. MERV 15 bag filters having the following characteristics: Efficiency of > 95% based on testing per ASHRAE Standard 52. This option shall be available with 2 in. or 4 in. pre-filters.

- e. 12 in. MERV 14 cartridge filters having the following characteristics: Efficiency of no less than 90% based on testing per ASHRAE Standard 52 and a minimum average arrestance of >98%. This option shall be available with 2 in. or 4 in. pre-filters.

- f. Field use filter section. The section shall be 4 ft in length and include 2 in. MERV 7 pleated filters.

19. Final Air Filters:

Unit shall be factory-equipped with:

- a. 12 in. MERV 14 cartridge filters having the following characteristics: Efficiency of no less than 90% based on testing per ASHRAE Standard 52 and a minimum average arrestance of >98%. This option shall be available with 2 in. or 4 in. pre-filters.

- b. 19 in. MERV 15 bag filters having the following characteristics: Efficiency of > 95% based on testing per ASHRAE Standard 52. This option shall be available with 2 in. or 4 in. pre-filters.

- c. 12 in. MERV 17 HEPA (high efficiency particulate air) filter. This option shall be available with 2 in. or 4 in. pre-filters.

20. Totally Enclosed fan-cooled (TEFC) Motors:

Unit shall be equipped with premium efficiency TEFC supply fan motor. Power exhaust or return fan motor (if equipped) shall also be TEFC type.

21. VFD Bypass:

- a. VFD Bypass shall be UL Listed by the drive manufacturer as a complete assembly and carry a UL 508 label.

- b. The VFD bypass shall be a complete factory-wired and tested bypass system consisting of an output contactor and bypass contactor. Overload protection and shall be provided in both drive and bypass modes.

- c. The following operators shall be provided:

- 1) Drive mode selector.
- 2) Bypass mode selector.

- d. When selector set to bypass, normally open contacts shall close to provide the bypass status to the unit's control system. While in bypass mode, the control system shall operate the supply fan using relay contacts to control the bypass contactor.

- e. Motor overload protection shall be included.

22. Supply Fan Static Pressure Control (VAV Units):

Variable air volume units shall be equipped with a supply fan VFD. The VFD shall control motor speed to maintain set point static pressure control at the supply duct sensor tube location. The supply fan drive shall be field-adjustable to maintain supply duct static pressure set point from 0.0-in. wg to 5-in. wg, adjusted via scrolling marquee display or Navigator™ display. A pressure transducer shall be factory-mounted and wired. (Control tubing from sensor tube location to transducer shall be field-supplied and installed.) Transducer shall provide a 4 to 20 mA signal to the unit control module; unit control module shall provide a 4 to 20 mA signal to the VFD indicating desired VFD output level.

23. Staged Air Volume (SAV)™ Units:

Staged air volume units shall be equipped with a supply fan VFD. The VFD shall control motor speed to user configurable speeds. High speed shall be a percentage of 60 Hz, and shall be user configurable. The range of adjustment for high speed shall be between 50 and 100% of 60 Hz. Low speed shall be a percentage of 60 Hz, and shall be user configurable. The range of adjustment for low speed shall be

- between 33 and 67% of 60 Hz. The control shall allow user-configurable fan speeds for cooling and heating modes.
24. Modulating Gas Heat:
- a. Modulating gas heat option shall monitor unit supply-air temperature and control the unit heat exchanger to provide the following sequences:
 - 1) First-stage demand heating control, with modulation to maintain user-configured heating supply air temperature set point. Turndown ratio to be at least 7:1 for the smallest low heat option, ranging up to 18:1 for the high heat options.
 - 2) Full-fire demand heating on heating control command.
 - 3) Tempering heat control, based on user-configured ventilation supply air temperature set point, to eliminate cold draft conditions with low mixed-air temperatures.
 - b. Modulating gas control option shall consist of:
 - 1) Modulating controller capable of ensuring the proper fuel air mixture at operating firing rates.
 - 2) Supply-air temperature thermistors with duct-mounting base.
 - 3) Limit switch temperature thermistor.
 - 4) Stainless steel heat exchanger tubes.
 - c. Field installation shall be limited to installing three supply air temperature thermistors in the supply duct. All other hardware, wiring and piping shall be factory-completed.
25. Stainless Steel Gas Heat Exchanger:
Heat exchanger shall be constructed of minimum 20-gage Type 409 Stainless Steel for corrosion resistance. Tubing material shall be suited for high temperature and corrosion resisting service. Tubing material shall comply with ASTM A268, Grade TP409. Tubing shall be welded and annealed.
26. Discharge Plenum:
Discharge plenum design shall contain added length module for bottom supply air discharge, as shown in contract drawings. Discharge plenum design shall provide horizontal discharge arrangement supply fan which shall discharge into insulated plenum. Interior cabinet surfaces within discharge plenum section shall be lined with sheet metal on all surfaces, insulated on the side opposite the airstream.
27. Blank section:
A 4 ft or 8 ft blank section shall be available for field installation of field-supplied devices.
28. Extended Chassis:
Extended chassis designs shall contain an added length module, after the evaporator section, as shown in the contract drawings. Module shall contain tracks to accept field-supplied and installed auxiliary heating coil.
29. Agion¹ Interior:
Interior panels shall be pre-coated with a silver zeolite antimicrobial material registered by the US EPA for use in HVAC applications.
30. Split Unit:
The unit shall be available for shipment in two sections dependent upon the options selected.
31. UV-C (Ultraviolet Band C) Germicidal Lamps:
Emitters and fixtures for UV-C lamps shall be designed for use inside an HVAC system and shall be covered by a 1-year warranty. Individual lamp output shall be measured in an ASME (American Society of Mechanical Engineers) nozzled test apparatus using a 45°F airstream moving at not less than 400 fpm. Lamp output at 253.7 nm shall not be less than 10 $\mu\text{W}/\text{cm}^2$ per inch of arc length measured at a distance of one meter.
- a. Power supplies for UV-C lamps shall be a high-efficiency electronic type which are matched to the emitters and are capable of producing the specified output intensity with an input power no more than 80 watts.
 - b. Fixtures for UV-C lamps shall be factory-installed and wired to a SPDT disconnect switch and door interlock switches in each door. Fixtures are wired for 120 v/single phase requiring a minimum circuit ampacity of 15 amps. Field power connections are made at the switch box mounted on the exterior of the unit. Lamps shall ship separately for field installation to minimize the chance for bulb damage.
 - c. Emitters and fixtures shall be installed in sufficient quantity and arranged so as to provide an equal distribution of UV-C energy on the coil and drain pan.
 - d. The minimum UV-C energy striking the leading edge of the coil pan shall be not less than 820 $\mu\text{W}/\text{cm}^2$ at the closest point and through placement, not less than 60% of that value at the farthest point. Equal amounts are to strike the drain pan, either directly or indirectly through reflection.
 - e. Emitters and fixtures shall be installed such that UV-C energy strikes all surfaces of the coil, drain pan, and the available line of sight airstream.
32. Marine Lights:
Marine Lights shall be:
- a. Cast, non-ferrous metal, weatherproof, fixture.

1. Agion is a trademark of Sciesent.

- b. Cast, non-ferrous metal, weatherproof, electrical junction box.
 - c. Gasketed, heat and shock resistant glass globe protects against moisture and debris.
 - d. Cast, non-ferrous metal lamp guard to protect glass globe.
 - e. UL listed.
 - f. 100 watt type “A” lamp maximum capacity.
 - g. Each fixture is equipped with a 75 watt, 130 volt, long life, vibration resistant, lamp (8000+ hour typical lamp life), factory-installed.
 - h. Metallic, single gang, electrical junction box, UL listed.
 - i. Factory-supplied and wired, SPST, UL listed toggle switch.
 - j. Each fixture is factory-wired to an externally mounted switch box. (Field power connections are made to the switch box mounted externally on the unit.)
 - k. All factory wiring penetrating through the panel is protected in “RIGID” type metal conduit.
33. Non-Fused Disconnect:
A non-fused electrical disconnect for main unit power shall be factory-installed. The disconnect shall be an interlocking through-the-door type.
34. Fused Disconnect:
A fused electrical disconnect for main unit power shall be factory-installed. The disconnect shall be an interlocking through-the-door type.
35. 115-Volt Convenience Outlet:
A duplex GFCI (ground fault circuit interrupt) receptacle shall be factory-mounted in a weatherproof enclosure and wired for a 10-amp load. It will remain powered when all unit circuit breakers have been turned off. The outlet will be deenergized by the unit disconnect.
36. Phase/Voltage Monitor:
Package shall include a device capable of detecting under/over voltage, phase loss or phase shift. The device shall take action to protect the unit if an abnormal condition is detected.
37. Short Circuit Current Rating (SCCR):
An optional SCCR of 65 kA shall be provided for 460-volt units. An optional of 25 kA shall be provided for 575-volt units.
38. Navigator™ Display Module Accessory:
The Navigator display module shall be a portable hand-held display module with a minimum of 4 lines and 20 characters per line, of clear English language. Display menus shall provide clear language descriptions of all menu items, operating modes, configuration points and alarm diagnostics. Reference to factory codes shall not be accepted. An industrial grade coiled extension cord shall allow the display module to be moved around the rooftop. Magnets shall hold the display module to any sheet metal panel to allow hands-free operation. Display module shall have NEMA 4x housing suitable for use in outdoor environments. Display shall have back light and contrast adjustment for easy viewing in bright sunlight or night conditions. The display module shall have raised surface buttons with positive tactile response.
39. Controls Expansion Module (CEM):
Factory-installed package shall include all hardware for additional control of base unit operation and product integrated controls features. The functions supported are:
- a. Building pressurization, evacuation, and smoke purge control.
 - b. Supply air reset from external 4 to 20 mA signal.
 - c. Two-step demand limit inputs (when used with the CCN [Carrier Comfort Network®] network).
 - d. Indoor air quality (IAQ) switch monitoring.
 - e. Outdoor airflow monitoring
 - f. Outdoor humidity monitoring.
 - g. Space humidity monitoring (required for dehumidification control, reheat and humidifier control).
 - h. Return air humidity monitoring.
 - i. Demand limiting from an external 4 to 20 mA signal.
 - j. Static pressure reset from an external 4 to 20 mA signal.
 - k. Pre and post filter switch monitoring.
40. Relative Humidity Sensors:
Package shall contain either duct-mounted or wall-mounted sensors to measure the relative humidity of the air within the occupied space (specify location) or return duct and/or outside air.
NOTE: For relative humidity sensor monitoring, the CEM must also be ordered.
41. Indoor Air Quality (CO₂) Sensor:
- a. Shall have the ability to provide demand ventilation indoor-air quality (IAQ) control through the economizer with an indoor air quality sensor.
 - b. The IAQ sensor shall be available in duct mount, wall mount, and wall mount with LED display of CO₂ in parts per million. The set point shall have adjustment capability.
42. Return Air Smoke Detector:
The smoke detector shall send input to the controller to shut down the unit in case smoke is detected.

43. Airflow Sensor:
Airflow sensor package shall contain a airflow station with airflow sensor, a transducer and all hardware required to measure the quantity of air. Optional economizer and CEM are required with this option. Sensor package shall be available for outdoor air, supply air, and exhaust air flows.
44. Differential Enthalpy Switch or Sensors (when equipped with both return air and outdoor air humidity sensors):
- For use with economizer only.
 - Capable of comparing heat content (temperature and humidity) of outdoor and return air and controlling economizer cut-in point at the most economical level.
45. Phase/Voltage Monitor:
Package shall include a device capable of detecting under/over voltage, phase loss or phase shift. The device shall take action to protect the unit if an abnormal condition is detected.
46. BACnet¹ Communication Option:
Shall provide factory-installed communication capability with a BACnet MS/TP network. Allows integration with i-Vu[®] Open control system or a BACnet Building Automation System.
47. Modbus² Protocol Translator:
A controller-based accessory module shall provide CCN (Carrier Comfort Network[®]) access to MODBUS Remote Terminal Unit (RTU) protocol conversion.
48. LonWorks³ Protocol Translator:
A controller-based accessory module shall provide CCN access to LON FT-10A ANSI/EIA- 709.1 protocol conversion.
49. Space Temperature Sensor (T-56):
The T-56 space temperature sensor (for CV applications) shall monitor space temperature. Device shall be suited for wall mounting in the occupied space. The T-56 sensor shall incorporate a front-panel located slider switch to effect a remote change in set point of $\pm 5^{\circ}\text{F}$. The T-56 sensor shall also include a button used to initiate Unoccupied Override function.
50. Space Temperature Sensor (T-56) with CO₂ Sensor:
This device shall incorporate interior space temperature sensing and interior space CO₂ level monitoring functions. Space temperature sensor shall sense the actual temperature in the conditioned space via 10,000-ohm thermistor. Temperature set point adjustment potentiometer via slide scale shall provide $\pm 5^{\circ}\text{F}$ adjustment. The CO₂ sensor shall provide CO₂ measurement range of 0 to 2000 ppm. IAQ signal to unit base board terminals shall be 4 to 20 mA. Sensor shall be equipped with an override button for timed override. Sensor must be powered by a separate field-supplied 24-v transformer.
51. Roof Curb:
Designed to comply with criteria established by NRCA Guideline B-1986. Formed 14-gage galvanized steel with wood nailer strip as perimeter curb supporting the air-handling portion of unit, and rail for supporting the condenser portion of the unit.
52. Roof Curb Condenser Section:
Formed 14-gage galvanized steel with wood nailer strip for supporting condenser section of the unit to complete a full perimeter curb under entire unit.
53. Low Compressor Sound Blanket:
Low compressor sound blanket accessory shall be available for field installation.

1. BACnet is a registered trademark of ASHRAE (American Society of Heating, Refrigerating, and Air-Conditioning Engineers).
2. Modbus is a registered trademark of Schneider Electric.
3. LonWorks is a registered trademark of Echelon Corporation.

Packaged Rooftop Cooling Unit with *ComfortLink* Controls and Optional Electric or Hydronic Heat

HVAC Guide Specifications — Section 50N2,N3,N4,N5,N6,N7,N8,N9

Size Range: 75 to 150 Tons, Nominal

Carrier Model Number:

50N2 (Vertical Supply/Return, Constant Volume [CV] Application, Staged Air Volume [SAV™])

50N3 (Vertical Supply/Return, Variable Air Volume [VAV] Application)

50N4 (Horizontal Supply/Return, Constant Volume Application, Staged Air Volume)

50N5 (Horizontal Supply/Return, Variable Air Volume Application)

50N6 (Vertical Supply/Horizontal Return, Constant Volume Application, Staged Air Volume)

50N7 (Vertical Supply/Horizontal Return, Variable Air Volume Application)

50N8 (Horizontal Supply/Vertical Return, Constant Volume Application, Staged Air Volume)

50N9 (Horizontal Supply/Vertical Return, Variable Air Volume Application)

NOTE: Items throughout the specification which apply only to units with electric or hydronic heat are indicated by single brackets [i.e.,].

Part 1 — General

1.01 SYSTEM DESCRIPTION

Outdoor, roof-curb mounted, electronically controlled cooling [and heating] unit utilizing hermetic scroll compressors with crankcase heaters for cooling duty [and utilizing electric resistance coils for heating duty]. Units shall supply air vertically or horizontally and return air vertically or horizontally as shown on the contract drawings.

1.02 QUALITY ASSURANCE

- A. The management system governing the manufacture of this product is ISO (International Organization for Standardization) 9001:2015 certified.
- B. Unit shall be rated in accordance with AHRI (Air-Conditioning, Heating, and Refrigeration Institute) Standard 340/360, latest edition.
- C. Unit shall be designed to conform to ANSI (American National Standards Institute)/ASHRAE (American Society of Heating, Refrigeration and Air-Conditioning Engineers) 15 (latest edition), ASHRAE 62, and UL Standard 1995.
- D. Unit shall be listed by ETL and ETL, Canada, as a total package.
- E. Roof curb shall be designed to NRCA (National Roofing Contractors Association) criteria per Guide-line B-1986.
- F. Insulation and adhesive shall meet NFPA (National Fire Protection Association) 90A requirements for flame spread and smoke generation.

1.03 DELIVERY, STORAGE, AND HANDLING

- A. All units shall be completely shrink-wrapped from the factory for protection during shipment. Tarping of units is unacceptable.
- B. Inspect for transportation damage and store in clean dry place and protect from weather and construction traffic. Handle carefully to avoid damage to components, enclosures, and finish.

Part 2 — Products

2.01 EQUIPMENT

- A. Factory-assembled, single-piece heating and cooling unit. Contained within the unit enclosure shall be all factory wiring, piping, refrigerant charge (R-410A), operating oil charge, dual refrigerant circuits, micro-processor-based control system and associated hardware, and all special features required prior to field start-up.
- B. Unit Cabinet:
 1. Unit shall be double-wall construction with insulation sealed between the inner and outer panels. Panel assemblies shall not carry an R-value of less than 10. The panels shall be galvanized steel (designated G60 per ASTM Standard A653 - minimum coating weight of 0.6 oz of zinc per square foot), bonderized and primer-coated on both sides and coated with a baked polyester thermosetting powder coating finish on the outer surface.
 2. Unit casing shall be capable of withstanding ASTM (American Society for Testing and Materials) Standard B117 500-hour salt spray test.
 3. Casing shall be watertight at negative 7 in. wg of internal pressure when tested per the UL 1995 rain test requirements. Leakage rate shall be tested and documented on a routine basis on random production units.
 4. Sides shall have person-size hinged access doors for easy access to the control box and other areas requiring servicing. Each door shall seal against a rubber gasket to prevent air and water leakage. Access doors shall be one piece, double-wall construction with insulation sealed between the inner and outer panels. Panel assemblies shall not carry an R-value of less than 10. Access doors shall be equipped with tiebacks.
 5. Side panels shall be easily removable for access to unit and shall seal against a full perimeter automotive style gasket to ensure a tight seal.
 6. Unit shall contain a double sloped drain pan, to prevent standing water from accumulating. Pan shall be fabricated of stainless steel. Unit shall contain a factory-installed nonferrous main condensate drain connection.
 7. Top cover of airside section to be sloped to prevent standing water.

8. Units shall be equipped with lifting lugs to facilitate overhead rigging. Lifting lugs shall also be suitable as tie down points.
- C. Compressors:
1. Fully hermetic scroll type compressors with overload protection and short cycle protection with minimum on and off timers.
 2. Factory rubber-in-shear mounted for vibration isolation.
 3. Reverse rotation protection capability.
 4. Crankcase heaters shall only be activated during compressor off mode.
- D. Coils:
1. Evaporator Coil:
 - a. Intertwined circuiting constructed of aluminum fins mechanically bonded to seamless copper tubes.
 - b. Full-face active type during full and part load conditions.
 - c. Coils shall be leak tested at 150 psig and pressure tested at 650 psig.
 2. Condenser Coils:
 - a. Condenser coils shall be microchannel design. The coils shall have a series of flat tubes containing a series of multiple, parallel flow microchannels layered between the refrigerant manifolds. Microchannel coils shall consist of a two-pass arrangement. Coil construction shall consist of aluminum alloys for the fins, tubes and manifolds.
 - b. Air-cooled condenser coils shall be leak tested at 150 psig and pressure tested at 650 psig.
- E. Fans:
1. Supply Fan:
 - a. Unit shall have only one fan wheel, scroll, and motor.
 - b. Fan scroll, wheel, shaft, bearings, drive components and motor shall be mounted on a formed steel assembly which shall be isolated from the unit outer casing with factory-installed 2-in. deflection spring isolators and vibration-absorbent fan discharge seal.
 - c. Fan shall be double-width, double-inlet, centrifugal belt-driven airfoil type with single outlet discharge.
 - d. Fan wheel shall be designed for continuous operation at the maximum rated fan speed and motor horsepower.
 - e. Fan wheel and shaft shall be selected to operate at 25% below the first critical speed and shall be statically and dynamically balanced as an assembly.
 - f. Fan shaft shall be solid steel, turned, ground and polished, and coated with rust preventative oil.
 - g. Fan shaft bearings shall be self-aligning, pillow-block, regreasable ball or roller-type selected for a minimum average life of 200,000 hours at design operating conditions in accordance with ANSI B3.15.
 - h. A single motor shall be mounted within the fan section casing on slide rails equipped with adjusting screws. Motor shall be mounted on a horizontal flat surface and shall not be supported by the fan or its structural members. Motor speed shall be controlled by a variable frequency drive.
 - i. Fan drive shall be constant-speed fixed-pitch. All drives shall be factory-mounted, with belts aligned and tensioned.
 - j. Shall include a high static pressure safety switch installed into the supply air plenum.
 - k. A high-static supply fan option shall be available.
2. Condenser Fans:
 - a. Direct-driven propeller type.
 - b. Discharge air vertically upward.
 - c. Protected by PVC-coated steel wire safety guards.
 - d. Statically and dynamically balanced.
 - e. Three-phase, totally enclosed motors.
- F. Variable Frequency Drive:
- All supply fan (and power exhaust fan and/or return fan motors, if equipped) shall be equipped with variable frequency drive (VFD) inverter. The VFD shall be provided with a metal enclosure and shall be factory-mounted, wired, and tested. The variable speed drive shall include the following features:
1. Full digital control with direct control from the unit *ComfortLink* controls.
 2. Insulated gate bi-polar transistors (IGBT) used to produce the output pulse width modulated (PWM) waveform, allowing for quiet motor operation.
 3. Inverters capable of operation at a frequency of 8 kHz so no acoustic noise shall be produced by the motor.
 4. VFDs shall include EMI/RFI (electromagnetic / radio frequency interference) filters.
 5. Digital display keypad module, mounted on the VFD enclosure.
 6. Local/Remote and Manual/Auto function keys on the keypad.
 7. UL-listed electronic overload protection.
 8. Critical frequency avoidance.
 9. Self diagnostics.
 10. On-board storage of unit manufacturer's customer user settings, retrievable from the keypad.

11. RS485 communications capability (accessory card source required).
 12. Internal thermal overload protection.
 13. 5% swinging (non-linear) chokes for harmonic reduction and improved power factor.
 14. All printed circuit boards shall be conformal coated.
 15. Shall, through ABB, qualify for a 24-month warranty from date of commissioning or 30 months from date of sale, whichever comes first.
- G. Outdoor-Air Hood Assembly:
Factory-installed motorized outdoor-air damper shall allow intake of up to 100% nominal airflow (on units not equipped with optional economizer).
- H. [Electric Heating Section:]
Electric resistance heaters shall be factory-installed, open wire nichrome element type, insulated with ceramic bushings, and shall include operating and safety controls.
- I. [Hydronic Heating Section:]
Hydronic heating option shall consist of factory-installed plate fin-tube coil assembly, installed in the extended length section. Coil assembly shall be supplied with die-formed casing and tube sheets of mill galvanized steel. Tubes shall be minimum 1/2-in. OD copper tubes mechanically expanded into aluminum plate fin coils with belled collars. Headers shall be constructed of steel with steel MPT connections. Headers shall have drain and vent connections. Coils shall be suitable for a design working pressure of 300 psig at 200°F. Coils shall be tested at 450 psig air pressure.
- J. [Steam Heating Section:]
Steam heating option shall consist of factory-installed plate fin-tube coil assembly, installed in the extended length section. The steam coil shall be non-freeze type heating coils:
1. Headers shall be steel with MPT connections.
 2. Inner steam distributing tubes shall be 5/8-in. OD, 0.020 in. wall thickness, located within 1 in. OD, 0.035 in. wall outer condensing tubes. Working pressure shall be 175 psig at 400°F.
- K. Refrigerant Components:
Unit shall be equipped with dual refrigerant circuits, each containing:
1. Filter drier.
 2. Moisture indicating sight glass.
 3. Two electronic expansion valves.
 4. Fusible plug.
- L. Filter Section:
1. Mixed air filter section shall consist of 2-in. thick, MERV (Minimum Efficiency Reporting Value) 5 disposable fiberglass filters of commercially available sizes. Optional pleated, bag and cartridge filters shall be available. (See special features section.)
 2. Factory 2-in. filter track shall allow easy field conversion to accept 4-in. thick, disposable fiberglass filters of commercially available sizes.
 3. Optional final filters with pre-filters shall be available. (See special features section.)
- M. Controls, Safeties, and Diagnostics:
1. Controls:
 - a. Control shall be accomplished through the use of a factory-installed, microprocessor-based control system and associated electronic and electrical hardware. Control system shall determine control sequences through monitoring the following operational variables:
 - 1) Day and Time.
 - 2) Schedule (Unoccupied/Occupied).
 - 3) Set points (Unoccupied/Occupied, Economizer, Duct Pressure, others).
 - 4) Space temperature.
 - 5) Outdoor-air temperature.
 - 6) Unit supply-air temperature.
 - 7) Unit return-air temperature.
 - 8) Supply-air fan status.
 - 9) Economizer position.
 - 10) Compressor suction and discharge pressure.
 - 11) Navigator display.
 - 12) Accessory and/or field-supplied sensors, function switches and/or signals.
 - b. Controls shall be capable of performing the following functions:
 - 1) Capacity control based on supply-air temperature and compensated by rate of change of return-air temperature (VAV) or room temperature (CV). Capacity control shall be accomplished through the use of compressor staging or optional variable output compressors.
 - 2) Perform a quick test to check the status of all input and output signals to the control system using the Navigator™ display.
 - 3) Control of integrated economizer operation, based on unit supply-air temperature.
 - 4) Supply fan volume control shall control output from a variable frequency drive to maintain duct static pressure at user-configured set point (VAV). Static pressure reset in conjunction with Carrier communicating terminals to reduce supply fan power requirements. Control system calculates the amount of supply static pressure reduction necessary to cause the most open damper in the system to open more than the minimum value (60%) but

- not more than the maximum value (90% or negligible static pressure drop).
- 5) Heating control shall provide space temperature control for unoccupied period heating, morning warm-up sequence and occupied period heating (when configured). Leaving-air temperature control shall be provided when unit is equipped with SCR controlled electric, hydronic or steam heat options.
 - 6) Adaptive optimal start shall determine the time unit will commence cooling (or heating or heating for morning warm-up) during the unoccupied mode to ensure occupied space reaches the set point in time for occupied mode.
 - 7) Adaptive optimal stop shall turn off the compressors a preset amount of time before the end of the occupied mode to conserve energy (CV only).
 - 8) Alerts and Alarms: Control shall continuously monitor all sensor inputs and control outputs to ensure safe and proper system operation. Alerts shall be generated whenever sensor conditions have gone outside criteria for acceptability. Alarms shall be initiated when unit control detects that a sensor input value is outside its valid range (indicating a defective device or connection that prevents full unit operation) or that an output has not functioned as expected or that a safety device has tripped. Current alarms shall be maintained in STATUS function; up to 9 (current or reset) shall be stored in HISTORY function for recall.
 - 9) Timed override function shall permit a system in unoccupied mode to be returned to occupied mode for a user-configured period of 1, 2, 3 or 4 hours by pressing the override button on the front of the space temperature sensor.
 - 10) Nighttime Free Cooling (NTFC) shall start the supply fan and open the economizer on cool nights to pre-cool the building structure mass using only outdoor air. Function shall be restricted to operation above a user-configured low lockout temperature set point.
 - 11) Modulating power exhaust control shall utilize a VFD to modulate capacity of exhaust fan system. Capacity of exhaust air shall be modulated in response to building static pressure at user-configured set point. Power exhaust fan operation shall be interlocked with supply fan operation.
 - 12) Return fan control (on optional return fan equipped units only) shall measure supply fan cfm and shall utilize a VFD to modulate the return fan to maintain constant cfm differential between supply and return fan. Return fan operation shall be interlocked with supply fan operation. Capacity of exhaust air shall be modulated in response to building static pressure at user-configured set point.
 - 13) Smoke control functions: Control shall initiate any of four separate smoke control functions in response to closure of field switches. Functions shall include: Pressurization, Evacuation, Smoke Purge, and Fire Shutdown. Should two or more switches be closed simultaneously, Fire Shutdown shall be initiated.
 - 14) Support demand controlled ventilation through a reset of the economizer's minimum position. This reset based on differential CO₂ ppm (outdoor and indoor) can be chosen as linear or as fast or slow-acting exponential curves.
 - 15) Indoor air quality (IAQ) mode shall admit fresh outdoor air into the space whenever space air quality sensors detect unsuitable space conditions, by overriding economizer minimum damper position. IAQ shall be permitted only during occupied periods, unless configured to be allowed during unoccupied periods also.
 - 16) Provide control for reheat via auxiliary heating coil during ventilation.
 - 17) IAQ pre-occupancy purge function shall provide complete exchange of indoor air with fresh air during unoccupied periods, when outdoor conditions permit. Function shall energize supply fan and open economizer two hours before next occupied period; duration of purge shall be user-configured (5 to 60 minutes).
 - 18) Outdoor Air Control (OAC) function shall maintain a minimum quantity of outdoor airflow into an occupied space. OAC mode shall be available only during an occupied period. Outdoor airflow shall be monitored by an airflow station and transducer. Economizer maximum damper opening position during OAC mode shall be user-configured.
 - 19) Dehumidification and Reheat: Dehumidification function shall override comfort condition set points to deliver cooler air into the space and satisfy a user-configured humidity set point at the space or return air humidity sensor. Reheat function shall energize an auxiliary heating device should dehumidification operation result in cooling of the space down to the occupied heating set point.

- 20) Supply Air Temperature Set Point Reset: Control shall automatically reset the unit supply air temperature set point on VAV models from either space temperature or return-air temperature, at user-configured rate and limit. Control shall also reset supply air temperature set point via external 2 to 10 vdc signal representing 0° to 20°F range of reset. Control shall respond to higher of either reset if both are active.
 - 21) Space Temperature Offset function shall permit occupants to adjust space temperature set point by $\pm 5^\circ\text{F}$ using T-56 space sensor (equipped with sliding scale adjuster).
 - 22) Lead-lag function shall distribute starts between the two refrigeration circuits in an effort to equalize the running time on the two circuits.
 - 23) Condenser-fan cycling control shall maintain correct head pressure down to 32°F.
 - 24) Refrigeration system pressures shall be monitored via pressure transducers. Alarms for low pressure, high pressure will be permitted.
 - 25) Timed Discrete Output function shall control an external function or device via user-configured activity schedule. This schedule shall be separate and different from the unit's occupied/unoccupied time schedule.
 - 26) Hydronic heating coil control shall modulate a control valve in a steam or hydronic heat system to maintain space temperature at user-configured set points. Control valve actuator shall communicate via LEN (Local Equipment Network) protocol.
 - 27) Humidifier control shall provide control for either LEN communicating control valve or discrete-type output, to maintain space humidity conditions at user-configured set points.
 - 28) Two-step demand limit control (when used in conjunction with CEM [controls expansion module]).
 - 29) Display in Metric units: Display may be configured to display data in Metric or English (Imperial) units of measure.
2. Safeties:
- Unit components shall be equipped with the following protections:
- a. Compressors:
 - 1) Overcurrent using calibrated circuit breakers (shuts down individual compressor).
 - 2) Crankcase heaters.
 - 3) High-pressure switch (shuts down individual circuit, automatic reset type).
 - 4) Low-pressure monitoring (shuts down individual circuit, automatic reset type).
 - b. Check filter switch.
 - c. Belt-Drive Fan Motors:

Overcurrent protection manual reset circuit breakers.
 - d. Supply Fan and Return Fan (when equipped):

High static pressure safety switch installed into the return air plenum.
 - e. [Electric Heating Section]:
 - 1) Automatic reset high-temperature limit switches.
 - 2) Manual reset high temperature limit switch.
 - 3) Primary and backup contactors.
 - 4) Branch circuit protection.
 - 5) Airflow proving switch.
3. Diagnostics:
- a. The display shall be capable of indicating a safety lockout condition (alarm).
 - b. The display shall also be capable of indicating an alert condition which does not lock out the unit, but informs the system monitor of a condition which could be detrimental to either the unit or the comfort of the occupants if allowed to continue.
 - c. Test mode must also be capable of displaying outputs of microprocessor-controller and to verify operation of every thermistor, actuator motor, fan, and compressor before unit is started.
4. Navigator™ Display Interface:
- The Navigator display module shall be a portable hand-held display module with a minimum of 4 lines and 20 characters per line, of clear English language. Display menus shall provide clear language descriptions of all menu items, operating modes, configuration points and alarm diagnostics. Reference to factory codes shall not be accepted. An industrial grade coiled extension cord shall allow the display module to be moved around the chiller. Magnets shall hold the display module to any sheet metal panel to allow hands-free operation. Display module shall have NEMA 4x housing suitable for use in outdoor environments. Display shall have back light and contrast adjustment for easy viewing in bright sunlight or night conditions. The display module shall have raised surface buttons with positive tactile response.
- N. Operating Characteristics:
1. Unit shall be capable of starting and running at 115°F (125°F for high-efficiency models) ambient

outdoor temperature per maximum load criteria of AHRI Standard 340/360, latest edition.

2. Unit shall be capable of mechanical cooling operation down to 32°F ambient outdoor temperature (–20°F with low ambient accessory).
3. Provides multi-stage cooling capability.
4. [Provides 2 stages of electric heating capability.]

O. Motors:

1. Compressor motors shall be cooled by suction gas passing over motor windings.
2. Condenser-fan motors shall be 3-phase, totally enclosed type with permanently lubricated ball bearings and internal overtemperature protection.
3. Supply and exhaust fan motors shall be of the 3-phase, NEMA (National Electrical Manufacturers Association) rated, open drip-proof (ODP), ball bearing type, with efficiencies per EISA (Energy Independence and Security Act) of 2007 (U.S.A.) requirements.

P. Electrical Requirements:

All unit power wiring shall enter unit cabinet at a single location.

Q. Special Features:

1. Digital Compressor:

A digital compressor shall be available on the lead circuit for constant volume and variable air volume configurations. The *ComfortLink* control system shall be capable of unloading this compressor in an infinite number of steps from 100% of unit capacity down to 50% of unit capacity.

2. Humidi-MiZer® Adaptive Dehumidification:

The Humidi-MiZer dehumidification system shall be factory installed with an e-coated reheat coil, and shall provide greater dehumidification of the occupied space by using two modes of dehumidification instead of the normal design cooling mode of the unit:

- a. Subcooling mode shall further sub-cool the hot liquid refrigerant leaving the condenser coil when both temperature and humidity in the space are not satisfied.
- b. Hot gas reheat mode shall mix a portion of the hot gas from the discharge of the compressor with the hot liquid refrigerant leaving the condenser coil to create a two-phase heat transfer in the system, resulting in a neutral leaving-air temperature.
- c. The system shall be equipped with modulating control valves to provide precise leaving-air temperature control. On-off, cycling type control shall not be acceptable.

3. Condenser Coil Protective Coating - E-Coated Microchannel Coil:

E-coated aluminum microchannel coils shall have a flexible epoxy polymer coating uniformly applied to all coil external surface areas without material bridging between fins or louvers. Coating process shall ensure complete coil encapsulation, including all exposed fin edges. E-coat thickness of 0.8 to 1.2 mil with top coat having a uniform dry thickness from 1.0 to 2.0 mil on all external coil surface areas, including fin edges, shall be provided. E-coated coils shall have superior hardness characteristics of 2H per ASTM D3363-00 and cross-hatch adhesion of 4B-5B per ASTM D3359-02. E-coated coils shall have superior impact resistance with no cracking, chipping, or peeling per NSF/ANSI 51-2002 Method 10.2.

4. Condenser Coil Louvered Guard:

Louvered panels complete with support retainers and fasteners shall be provided for protection of condenser coils.

5. Condenser Coil Grille Guard:

Welded wire grille complete with support retainers and fasteners shall be provided for protection of condenser coils.

6. Low Outdoor Sound:

Low sound fans for outdoor sound reduction shall be available as a factory-installed option for all units (except 90-ton high-efficiency, 105-ton, 120-ton high-efficiency, 130-ton high-efficiency, and 150-ton units).

7. Low Ambient Control:

- a. Control shall regulate fan motor speed in response to the saturated condensing temperature of the unit. The control shall be capable of operating with outdoor temperatures at –20°F.
- b. Motormaster® low ambient control shall be available as a factory-installed option or field-installed accessory for all units.

8. Service Valves:

Shall be equipped with ball type service valves in the suction, discharge, and liquid line for each circuit.

9. Replaceable Core Filter Drier:

Shall be equipped with a replaceable core filter drier with isolation valves in each liquid line.

10. Hot Gas Bypass:

Unit shall be factory-equipped with hot gas bypass valve, and tubing to maintain capacity control at minimal cooling loads.

11. Evaporator Coil Options:

- a. Copper-fin coils shall be constructed of copper fins mechanically bonded to copper tubes and copper tube sheets. Galvanized steel tube sheets shall not be acceptable. A

polymer strip shall prevent coil assembly from contacting the sheet metal coil pan to minimize potential for galvanic corrosion between coil and pan. All copper construction shall provide protection in moderate coastal environments.

- b. E-coated aluminum-fin coils shall have a flexible epoxy polymer coating uniformly applied to all coil surface areas without material bridging between fins. Coating process shall ensure complete coil encapsulation. Color shall be high gloss black with gloss - 60 deg of 65 to 90% per ASTM D523-89. Uniform dry film thickness from 0.8 to 1.2 mil on all surface areas including fin edges. Superior hardness characteristics of 2H per ASTM D3363-92A and cross-hatch adhesion of 4B-5B per ASTM D3359-93. Impact resistance shall be up to 160 in./lb (ASTM D2794-93). Humidity and water immersion resistance shall be up to minimum 1000 and 250 hours respectively (ASTM D2247-92 and ASTM D870-92). Corrosion durability shall be confirmed through testing to be no less than 1000 hours salt spray per ASTM B117-90. Coil construction shall be aluminum fins mechanically bonded to copper tubes.

12. Motorized Outdoor Air Damper:

- a. Package consisting of dampers, actuator, and linkages in conjunction with control system to provide outdoor air.
- b. Dampers shall be an ultra low-leakage type with blade and edge seals. Dampers shall exhibit a maximum leakage rate of 4 cfm per square foot of area at 1 in. wg pressure differential when tested in accordance with AMCA Standard 500.
- c. Dampers shall function as intended after 100,000 cycles when tested in accordance with Section 8, UL standard 555S.

13. Ultra Low Leak Economizer:

Dry bulb, differential dry bulb temperature, enthalpy, or optional differential enthalpy controlled integrated type consisting of dampers, actuator, and linkages in conjunction with control system to provide primary cooling using outdoor air, enthalpy permitting, supplemented with mechanical cooling when necessary.

- a. Economizer shall meet the requirements of the California Energy Commission Title 24 economizer requirements.
- b. Dampers shall be a gear driven ultra low leakage type with blade and edge seals. Dampers shall exhibit a maximum leakage rate of 3 cfm per square foot of area at 1 in. wg pressure differential when tested in

accordance with AMCA (Air Movement and Control Association) Standard 500.

- c. Dampers shall function as intended after 100,000 cycles when tested in accordance with Section 8, UL standard 555S.
 - d. Actuator shall have a spring-return feature which shuts dampers upon a power interruption or unit shutdown. Actuators are capable of internal diagnostics.
 - e. Equipped with a solid-state humidity sensor that is capable of sensing outdoor-air heat content (temperature and humidity) and controlling economizer cut-in point at most economical level. The user can also configure dew point limiting.
- ## 14. Modulating Power Exhaust with VFD:

Package shall include a double-width, double-inlet centrifugal belt drive, forward-curved power exhaust fan with variable frequency drive control to maintain a field adjustable interior space pressure set point.

- a. Fan bearings shall be of the pillow block type with an average design life of 200,000 hours.
- b. Fans shall be statically and dynamically balanced.
- c. Installation:
 - 1) Site installation shall require supply and installation of building pressure (BP) sensing pick-up and tube to connect to BP transducer in unit.
 - 2) All other wiring and pressure tubing shall be factory-supplied and factory-installed.
- d. Bypass for the VFD shall be available as a factory-installed option.
- e. A high-static power exhaust option shall be available.

15. Return Fan/Building Pressure Control:

- a. Functions provided shall be:
 - 1) Airflow control for return duct path (dedicated to overcoming flow losses in return duct system).
 - 2) Modulate return airflow rate to track supply fan airflow rate and maintain a user set delta cfm between the supply and return airflow.
 - 3) Maintain building pressure by sensing building pressure and modulating fan motor speed.
- b. Option shall consist of following hardware:
 - 1) Plenum fan assembly, with welded steel airfoil blade fan.
 - 2) Spring isolation.
 - 3) Belt-drive fan system, fixed pitch for maximum belt life and reliability.

- 4) Variable frequency drive (VFD) for return fan modulation control.
 - 5) Supply air cfm and return air cfm sensors to measure supply and return airflow.
 - 6) Exhaust damper with outlet hood.
 - 7) Building pressure transducer.
 - 8) High static pressure safety switch installed into the return air plenum.
- c. Installation:
- 1) Site installation shall require supply and installation of building pressure (BP) sensing pick-up and tube to connect to BP transducer in unit.
 - 2) All other wiring and pressure tubing shall be factory-supplied and factory-installed.
- d. A high-static return fan option shall be available.
16. Extended Lube Lines:
Unit shall be equipped with extended lube lines to facilitate lubrication of fan bearings from one side of the unit.
17. Belt Guard:
Unit shall be equipped with belt guard on all belt driven fans. The guard shall completely enclose the drive system and be removable for service.
18. Mixed Air Filters:
Unit shall be factory-equipped with:
- a. 4 in. MERV 8 pleated filters having the following characteristics: Efficiency of no less than 30% based on testing per ASHRAE Standard 52 and a minimum average arrestance of 95%.
 - b. 4 in. MERV 14 pleated filters having the following characteristics: Efficiency of no less than 90% based on testing per ASHRAE Standard 52 and a minimum average arrestance of >98%.
 - c. 12 in. MERV 14 bag filters having the following characteristics: Efficiency of no less than 90% based on testing per ASHRAE Standard 52 and a minimum average arrestance of >98%. This option shall be available with 2 in. or 4 in. pre-filters.
 - d. 19 in. MERV 15 bag filters having the following characteristics: Efficiency of > 95% based on testing per ASHRAE Standard 52. This option shall be available with 2 in. or 4 in. pre-filters.
 - e. 12 in. MERV 14 cartridge filters having the following characteristics: Efficiency of no less than 90% based on testing per ASHRAE Standard 52 and a minimum average arrestance of >98%. This option shall be available with 2 in. or 4 in. pre-filters.
 - f. Field use filter section. The section shall be 6 ft in length and include 2 in. MERV 7 filters.
19. Final Air Filters:
Unit shall be factory-equipped with:
- a. 12 in. MERV 14 cartridge filters having the following characteristics: Efficiency of no less than 90% based on testing per ASHRAE Standard 52 and a minimum average arrestance of >98%. This option shall be available with 2 in. or 4 in. pre-filters.
 - b. 19 in. MERV 15 bag filters having the following characteristics: Efficiency of > 95% based on testing per ASHRAE Standard 52. This option shall be available with 2 in. or 4 in. pre-filters.
 - c. 12 in. MERV 17 HEPA (high efficiency particulate air) filter. This option shall be available with 2 in. or 4 in. pre-filters.
20. Totally Enclosed fan-cooled (TEFC) Motors:
Unit shall be equipped with premium-efficiency TEFC supply fan motor. Power exhaust or return fan motor (if equipped) shall also be TEFC type.
21. VFD Bypass:
- a. VFD bypass shall be UL Listed by the drive manufacturer as a complete assembly and carry a UL 508 label.
 - b. The VFD bypass shall be a complete factory-wired and tested bypass system consisting of an output contactor and bypass contactor. Overload protection and shall be provided in both drive and bypass modes.
 - c. The following operators shall be provided:
 - 1) Drive mode selector
 - 2) Bypass mode selector
 - d. When selector set to bypass, normally open contacts shall close to provide the bypass status to the unit's control system. While in bypass mode, the control system shall operate the supply fan using relay contacts to control the bypass contactor.
 - e. Motor overload protection shall be included.
22. Supply Fan Static Pressure Control (VAV units):
Variable air volume units shall be equipped with a supply fan VFD. The VFD shall control motor speed to maintain set point static pressure control at the supply duct sensor tube location. The supply fan drive shall be field-adjustable to maintain supply duct static pressure set point from 0.0-in. wg to 5-in. wg, adjusted via scrolling marquee display or Navigator™ display. A pressure transducer shall be factory-mounted and wired. (Control tubing from sensor tube location to transducer shall be field-supplied and installed.) Transducer shall provide a 4 to 20 mA signal to the unit control module; unit control module

shall provide a 4 to 20 mA signal to the VFD indicating desired VFD output level.

23. Staged Air Volume (SAV™) units:

Staged air volume units shall be equipped with a supply fan VFD. The VFD shall control motor speed to user-configurable speeds. High speed shall be a percentage of 60 Hz, and shall be user configurable. The range of adjustment for high speed shall be between 50 and 100% of 60 Hz. Low speed shall be a percentage of 60 Hz, and shall be user configurable. The range of adjustment for low speed shall be between 33 and 67% of 60 Hz. The control shall allow user-configurable fan speeds for cooling and heating modes.

24. [SCR Controlled Electric Heat:]

a. SCR electric heat option shall monitor unit supply-air temperature and control the unit heater section to provide the following sequences:

- 1) Demand heating control, with modulation to maintain user-configured heating supply air temperature set point.
- 2) Full output heating on heating control command.
- 3) Tempering heat control, based on user-configured ventilation supply air temperature set point, to eliminate cold draft conditions with low mixed-air temperatures.

b. SCR heat control option shall consist of:

- 1) SCR controller capable of ensuring the proper heating rates.
- 2) Supply air temperature thermistors with duct-mounting base.
- 3) Limit switch temperature thermistors.

c. Field installation shall be limited to installing three supply air temperature thermistors in the supply duct. All other hardware and wiring shall be factory-completed.

25. Discharge Plenum:

Discharge plenum design shall contain added length module for bottom supply air discharge, as shown in contract drawings. Discharge plenum design shall provide horizontal discharge arrangement supply fan which shall discharge into insulated plenum. Interior cabinet surfaces within discharge plenum section shall be lined with sheet metal on all surfaces, insulated on the side opposite the airstream. Electric heat is not available with discharge plenum models.

26. Blank Section:

A 4 ft or 8 ft blank section shall be available for field installation of field-supplied devices.

27. Extended Chassis:

Extended chassis designs shall contain an added length module, after the evaporator section, as shown in the contract drawings. Module shall

contain tracks to accept field-supplied/installed auxiliary heating coil.

28. Agion¹ Interior:

Interior panels shall be pre-coated with a silver zeolite antimicrobial material registered by the US EPA for use in HVAC applications.

29. Split Unit:

The unit shall be available for shipment in two sections dependent upon the options selected.

30. UV-C (Ultraviolet Band C) Germicidal Lamps:

Emitters and fixtures for UV-C lamps shall be designed for use inside an HVAC system and shall be covered by a 1-year warranty. Individual lamp output shall be measured in an ASME (American Society of Mechanical Engineers) nozzled test apparatus using a 45°F airstream moving at not less than 400 fpm. Lamp output at 253.7 nm shall not be less than 10 μW/cm² per inch of arc length measured at a distance of one meter.

a. Power supplies for UV-C lamps shall be a high-efficiency electronic type which are matched to the emitters and are capable of producing the specified output intensity with an input power no more than 80 watts.

b. Fixtures for UV-C lamps shall be factory-installed and wired to a SPDT disconnect switch and door interlock switches in each door. Fixtures are wired for 120 v/single phase requiring a minimum circuit ampacity of 15 amps. Field power connections are made at the switch box mounted on the exterior of the unit. Lamps shall ship separately for field installation to minimize the chance for bulb damage.

c. Emitters and fixtures shall be installed in sufficient quantity and arranged so as to provide an equal distribution of UV-C energy on the coil and drain pan.

d. The minimum UV-C energy striking the leading edge of the coil pan shall be not less than 820 μW/cm² at the closest point and through placement, not less than 60% of that value at the farthest point. Equal amounts are to strike the drain pan, either directly or indirectly through reflection.

e. Emitters and fixtures shall be installed such that UV-C energy strikes all surfaces of the coil, drain pan, and the available line of sight airstream.

31. Marine Lamps:

Marine Lights shall be:

- a. Cast, non-ferrous metal, weatherproof, fixture.

1. Agion is a trademark of Sciessent.

- b. Cast, non-ferrous metal, weatherproof, electrical junction box.
 - c. Gasketed, heat and shock resistant glass globe protects against moisture and debris.
 - d. Cast, non-ferrous metal lamp guard to protect glass globe.
 - e. UL listed.
 - f. 100 watt type “A” lamp maximum capacity.
 - g. Each fixture is equipped with a 75 watt, 130 volt, long life, vibration resistant, lamp (8000+ hour typical lamp life), factory-installed.
 - h. Metallic, single gang, electrical junction box, UL listed.
 - i. Factory-supplied and wired, SPST, UL listed toggle switch.
 - j. Each fixture is factory-wired to an externally mounted switch box. (Field power connections are made to the switch box mounted externally on the unit.)
 - k. All factory wiring penetrating through the panel is protected in “RIGID” type metal conduit.
32. Non-Fused Disconnect:
A non-fused electrical disconnect for main unit power shall be factory-installed. The disconnect shall be an interlocking through-the-door type.
33. Fused Disconnect:
A fused electrical disconnect for main unit power shall be factory-installed. The disconnect shall be an interlocking through-the-door type.
34. 115-Volt Convenience Outlet:
A duplex GFCI (ground fault circuit interrupt) receptacle shall be factory-mounted in a weatherproof enclosure and wired for a 10-amp load. It will remain powered when all unit circuit breakers have been turned off. The outlet will be deenergized by the unit disconnect.
35. Phase/Voltage Monitor:
Package shall include a device capable of detecting under/over voltage, phase loss or phase shift. The device shall take action to protect the unit if an abnormal condition is detected.
36. Short Circuit Current Rating (SCCR):
An optional SCCR of 65 kA shall be provided for 460-volt units. An optional of 25 kA shall be provided for 575-volt units.
37. Navigator™ Display Module Accessory:
The Navigator display module shall be a portable hand-held display module with a minimum of 4 lines and 20 characters per line, of clear English language. Display menus shall provide clear language descriptions of all menu items, operating modes, configuration points and alarm diagnostics. Reference to factory codes shall not be accepted. An industrial grade coiled extension cord shall allow the display module to be moved around the rooftop. Magnets shall hold the display module to any sheet metal panel to allow hands-free operation. Display module shall have NEMA 4x housing suitable for use in outdoor environments. Display shall have back light and contrast adjustment for easy viewing in bright sunlight or night conditions. The display module shall have raised surface buttons with positive tactile response.
38. Controls Expansion Module (CEM):
Factory-installed package shall include all hardware for additional control of base unit operation and product integrated controls features. The functions supported are:
- a. Building pressurization, evacuation, and smoke purge control.
 - b. Supply air reset from external 4 to 20 mA signal.
 - c. Two-step demand limit inputs (when used with the CCN [Carrier Comfort Network®]).
 - d. Indoor air quality (IAQ) switch monitoring.
 - e. Outdoor airflow monitoring.
 - f. Outdoor humidity monitoring.
 - g. Space humidity monitoring (required for dehumidification control, reheat and humidifier control).
 - h. Return air humidity monitoring.
 - i. Demand limiting from an external 4 to 20 mA signal.
 - j. Static pressure reset from an external 4 to 20 mA signal.
 - k. Pre and post filter switch monitoring.
39. Relative Humidity Sensors:
Package shall contain either duct-mounted or wall-mounted sensors to measure the relative humidity of the air within the occupied space (specify location) or return duct and/or outside air.
NOTE: For relative humidity sensor monitoring, the CEM must also be ordered.
40. Indoor Air Quality (CO₂) Sensor:
a. Shall have the ability to provide demand ventilation indoor-air quality (IAQ) control through the economizer with an indoor air quality sensor.
b. The IAQ sensor shall be available in duct mount, wall mount, and wall mount with LED display of CO₂ in parts per million. The set point shall have adjustment capability.
41. Return Air Smoke Detector:
The smoke detector shall send input to the controller to shut down the unit in case smoke is detected.

Guide specifications — 50N units (cont)

42. Airflow Sensor:

Airflow sensor package shall contain a airflow station with airflow sensor, a transducer and all hardware required to measure the quantity of air. Optional economizer and CEM are required with this option. Sensor package shall be available for outdoor air, supply air, and exhaust airflows.

43. Differential Enthalpy Switch or Sensors (when equipped with both return air and outdoor air humidity sensors):

- a. For use with economizer only.
- b. Capable of comparing heat content (temperature and humidity) of outdoor and return air and controlling economizer cut-in point at the most economical level.

44. Phase/Voltage Monitor:

Package shall include a device capable of detecting under/over voltage, phase loss or phase shift. The device shall take action to protect the unit if an abnormal condition is detected.

45. BACnet¹ Communication Option:

Shall provide factory-installed communication capability with a BACnet MS/TP network. Allows integration with i-Vu[®] Open control system or a BACnet Building Automation System.

46. Modbus² Protocol Translator:

A controller-based accessory module shall provide CCN (Carrier Comfort Network[®]) access to MODBUS Remote Terminal Unit (RTU) protocol conversion.

47. LonWorks³ Protocol Translator:

A controller-based accessory module shall provide CCN access to LON FT-10A ANSI/EIA-709.1 protocol conversion.

48. Space Temperature Sensor (T-56):

The T-56 space temperature sensor (for CV applications) shall monitor space temperature. Device shall be suited for wall mounting in the occupied space. The T-56 sensor shall incorporate a front-panel located slider switch to effect a remote change in set point of $\pm 5^{\circ}\text{F}$. The T-56 sensor shall also include a button used to initiate Unoccupied Override function.

49. Space Temperature Sensor (T-56) with CO₂ Sensor:

This device shall incorporate interior space temperature sensing and interior space CO₂ level monitoring functions. Space temperature sensor shall sense the actual temperature in the conditioned space via 10,000-ohm thermistor. Temperature set point adjustment potentiometer via slide scale shall provide $\pm 5^{\circ}\text{F}$ adjustment. CO₂ sensor shall provide CO₂ measurement range of 0 to 2000 ppm. IAQ signal to unit base board terminals shall be 4 to 20 mA. Sensor shall be equipped with an override button for timed override. Sensor must be powered by a separate field-supplied 24-v transformer.

50. Roof Curb:

Designed to comply with criteria established by NRCA Guideline B-1986. Formed 14-gage galvanized steel with wood nailer strip as perimeter curb supporting the air-handling portion of unit, and rail for supporting the condenser portion of the unit.

51. Roof Curb Condenser Section:

Formed 14-gage galvanized steel with wood nailer strip for supporting condenser section of the unit to complete a full perimeter curb under entire unit.

52. Low Compressor Sound Blanket:

Low compressor sound blanket accessory shall be available for field installation.

1. BACnet is a registered trademark of ASHRAE (American Society of Heating, Refrigerating, and Air-Conditioning Engineers).
2. Modbus is a registered trademark of Schneider Electric.
3. LonWorks is a registered trademark of Echelon Corporation.