



# Installation, Start-Up and Service Instructions

## CONTENTS

	Page
<b>SAFETY CONSIDERATIONS</b> .....	1
<b>INSTALLATION GUIDELINES</b> .....	2
<b>Replacement/Retrofit —</b>	
<b>R-22 to Puron Refrigerant</b> .....	2
<b>Rated Indoor Airflow (cfm)</b> .....	2
<b>Identify Factory Options</b> .....	3
<b>Matching 38AU Model to Evaporator Coil</b> .....	3
<b>General</b> .....	3
<b>INSTALLATION</b> .....	7
<b>Jobsite Survey</b> .....	7
<b>Step 1 — Plan for Unit Location</b> .....	7
<b>Step 2 — Complete Pre-Installation Checks</b> .....	7
<b>Step 3 — Prepare Unit Mounting Support</b> .....	7
<b>Step 4 — Rig and Mount the Unit</b> .....	7
<b>Step 5 — Determine Refrigerant Line Sizes</b> .....	7
<b>Suction Riser</b> .....	11
<b>Step 6 — Complete Refrigerant Piping</b>	
<b>Connections</b> .....	11
<b>Step 7 — Install Accessories</b> .....	14
<b>Step 8 — Complete Electrical Connections</b> .....	15
<b>Step 9 — Wind Baffles for Low Ambient Control</b> ..	20
<b>PRE-START-UP</b> .....	20
<b>System Check</b> .....	20
<b>Turn On Crankcase Heater</b> .....	20
<b>Preliminary Charge</b> .....	20
<b>START-UP</b> .....	21
<b>Preliminary Checks</b> .....	21
<b>Start Unit</b> .....	21
<b>OPERATING SEQUENCE</b> .....	27
<b>Base Unit Controls</b> .....	27
<b>All Units</b> .....	27
<b>MAINTENANCE</b> .....	27
<b>Quarterly Inspection</b>	
<b>(and 30 days after initial start)</b> .....	27
<b>Seasonal Maintenance</b> .....	28
<b>SERVICE</b> .....	28
<b>Refrigeration System</b> .....	28
<b>Comfort Alert Diagnostic Module</b> .....	29
<b>Compressor Protection</b> .....	35
<b>Routine Cleaning of Round-Tube Plate Fin (RTPF)</b>	
<b>Coils</b> .....	35
<b>Fastener Torque Values</b> .....	36
<b>TROUBLESHOOTING</b> .....	36
<b>APPENDIX A — AIR CONDITIONER AND HEAT PUMP</b>	
<b>WITH PURON® — QUICK REFERENCE GUIDE</b> ..	38
<b>APPENDIX B — WIRING DIAGRAMS</b> .....	39
<b>APPENDIX C — LOW AMBIENT OPTION</b> .....	55

## START-UP CHECKLIST .....CL-1

### SAFETY CONSIDERATIONS

Improper installation, adjustment, alteration, service, maintenance, or use can cause explosion, fire, electrical shock or other conditions which may cause personal injury or property damage. Consult a qualified installer, service agency, or your distributor or branch for information or assistance. The qualified installer or agency must use factory-authorized kits or accessories when modifying this product. Refer to the individual instructions packaged with the kits or accessories when installing.

Follow all safety codes. Wear safety glasses and work gloves. Use quenching cloths for brazing operations and have a fire extinguisher available. Read these instructions thoroughly and follow all warnings or cautions attached to the unit. Consult local building codes and appropriate national electrical codes (in U.S.A., ANSI/NFPA70, National Electrical Code (NEC); in Canada, CSA C22.1) for special requirements.

It is important to recognize safety information. This is the safety-alert symbol . When you see this symbol on the unit and in instructions or manuals, be alert to the potential for personal injury.

Understand the signal words DANGER, WARNING, CAUTION, and NOTE. These words are used with the safety-alert symbol. DANGER identifies the most serious hazards which **will** result in severe personal injury or death. WARNING signifies hazards which **could** result in personal injury or death. CAUTION is used to identify unsafe practices, which **may** result in minor personal injury or product and property damage. NOTE is used to highlight suggestions which **will** result in enhanced installation, reliability, or operation.

** DANGER**

**ELECTRICAL SHOCK HAZARD**

Failure to follow this warning will result in personal injury or death.

Before performing service or maintenance operations on unit, turn off main power switch to unit and install lock(s) and lockout tag(s). Ensure electrical service to rooftop unit agrees with voltage and amperage listed on the unit rating plate. Unit may have more than one power switch.

** WARNING**

**UNIT OPERATION AND SAFETY HAZARD**

Failure to follow this warning could cause personal injury, death and/or equipment damage.

R-410A refrigerant systems operate at higher pressures than standard R-22 systems. Do not use R-22 service equipment or components on R-410A refrigerant equipment.

**⚠ WARNING**

**PERSONAL INJURY AND ENVIRONMENTAL HAZARD**

Failure to follow this warning could cause personal injury or death.

Relieve pressure and recover all refrigerant before system repair or final unit disposal.

Wear safety glasses and gloves when handling refrigerants. Keep torches and other ignition sources away from refrigerants and oils.

**⚠ CAUTION**

**PERSONAL INJURY HAZARD**

Failure to follow this caution may result in personal injury.

Sheet metal parts may have sharp edges or burrs. Use care and wear appropriate protective clothing, safety glasses and gloves when handling parts and servicing air conditioning equipment.

**INSTALLATION GUIDELINES**

**Replacement/Retrofit — R-22 to Puron Refrigerant**

Replacement/retrofit installations require change-out of outdoor unit, metering device, and filter driers. Change-out of indoor coil (evaporator) and interconnecting tubing is recommended.

**EXISTING EVAPORATOR COIL**

If the existing evaporator coil may be re-used, check with the coil manufacturer to verify the coil construction is suitable for operation with the higher pressures of Puron® refrigerant (R-410A). Also determine if the existing TXV valve is compatible with R-410A, replace if necessary. The minimum factory test pressure rating must be 250 psig (1725 kPa). Existing coil will need to be purged with Nitrogen to remove as much mineral oil as possible to eliminate cross contamination of oils.

**ACID TEST**

If the existing system is being replaced because of a compressor electrical failure, assume acid is in system. If system is being replaced for any other reason, use an approved acid test kit to determine acid level. If even low levels of acid are detected, install a 100 percent activated alumina suction-line filter drier in addition to the replacement liquid-line filter drier. Remove the suction line filter drier as soon as possible, with a maximum of 72 hr of operation. Recommendation: Install a ball valve in the liquid line at the filter drier location when installing a suction filter in the suction line.

**EXISTING REFRIGERATION PIPING**

Reuse of existing refrigerant piping involves three issues: quality (strength) of existing tubing, cleanliness and tube size. Inspect all tube segments and joints for signs of damage, corrosion or poor brazing. Flush the interconnecting piping system with dry Nitrogen to eliminate as much trace of mineral oil as possible.

Same tube sizes are capable of handling higher flowrates (expressed as tons of cooling capacity) with Puron refrigerant compared to R-22 at constant pressure drops. For example, a 1/2-inch OD liquid line is rated at 33% higher tons with Puron than with R-22 (at 5°F pressure drop). A 1-1/8 inch OD suction line is rated at 53% higher tons with Puron than with R-22 (at 2°F pressure drop). Refrigeration lines selected for R-22 use are

typically oversized for Puron applications. Carefully check the existing suction line size against the table for maximum size; replace vertical riser segments if necessary. Check existing liquid line size against sizing data in Tables 7 and 8 or; replace with smaller lines when feasible.

**INSTALLATION**

1. Remove the existing evaporator coil or fan coil and install the replacement coil when appropriate.
2. Drain oil from low points and traps in suction line tubing and evaporator if they were not replaced. Removing oil from evaporator coil may require purging of the tubing with dry nitrogen.
3. Unless indoor unit is equipped with a Puron approved metering device, change the metering device to a thermal expansion valve (TXV) designed for Puron refrigerant (R-410A).
4. Remove the existing outdoor unit. Install the new outdoor unit according to these installation instructions.
5. Install a new field-supplied liquid-line filter drier at the indoor coil just upstream of the TXV or fix orifice metering device.
6. If a suction line filter drier is also to be installed, install suction line drier downstream of suction line service valve at condensing unit.

**⚠ CAUTION**

**EQUIPMENT DAMAGE**

Failure to follow this caution can result in equipment damage.

Do not install a suction-line filter drier in liquid line. A liquid-line filter drier designed for use with R-410A refrigerant is required on every unit.

7. If required, install a 100% activated alumina suction line filter drier at the outdoor unit.
8. Evacuate and charge the system according to the instructions in this installation manual.
9. Operate the system for 10 hr. Monitor the pressure drop across the suction line filter drier. If pressure drop exceeds 3 psig (21 kPa), replace suction-line and liquid-line filter driers. Be sure to purge system with dry nitrogen and evacuate when replacing filter driers. Continue to monitor the pressure drop across suction-line filter drier. Repeat filter changes if necessary. Never leave suction-line filter drier in system longer than 72 hr (actual time).

**Rated Indoor Airflow (cfm)**

Tables 1 and 2 lists the rated indoor airflow used for the AHRI efficiency rating for the units covered in this document.

**Table 1 — 38AUZ with 40RUA**

MODEL NUMBERS	FULL LOAD AIRFLOW (CFM)
38AUZ16	6000
38AUZ25	8300

**Table 2 — 38AUD with 40RUA**

MODEL NUMBERS	FULL LOAD AIRFLOW (CFM)
38AUD16	5625
38AUD25	8000
38AUD28	9375

## Identify Factory Options

Factory options will affect 38AU unit pipe sizing selections.

Coil type impacts liquid lift limits; Check this unit's Model Number against the Model Number Nomenclature, Fig. 1. Determine the significance of this unit's values in Position 11 (Coil type). For date of unit manufacture see Serial Number Nomenclature, see Fig. 2.

## Matching 38AU Model to Evaporator Coil

The Model 38AUZ is a single-circuit unit design, requiring one set of refrigeration piping. This model can be connected to an evaporator coil with one circuit or with two circuits (by manifolding the evaporator connections into a single piping system).

The Model 38AUD is a dual-circuit unit design that requires two sets of refrigeration piping between the outdoor unit and the evaporator coil (or coils). This model can only be connected to an evaporator coil that has two refrigeration circuits (or to two separate evaporator coils). The Model 38AUD CANNOT be

connected to a single-circuit evaporator coil. The Model 38AUD CANNOT be field-converted to a single-circuit design. See Table 3.

**Table 3 — Evaporator Coil Connections**

EVAPORATOR COIL HAS	CONNECT TO MODEL	NOTES
Single Circuit	38AUZ ONLY	—
Two Circuits	38AUZ	Manifold evaporator circuits into single piping system.
	38AUD	Use two separate piping systems

Before unpacking this new 38AU model, compare the evaporator coil design to the 38AU model.

## General

For unit dimensions and corner weights see Fig. 3 and 4. For physical data see Tables 4 and 5.

1	2	3	4	5	6	7	8	9	10	11	12	13	14	15	16	17	18
3	8	A	U	D	T	2	5	A	0	A	6	-	0	A	0	A	0

**Model Type**  
38AU = Carrier Condensing Unit  
Puron® R-410A Refrigerant

---

**Type of Coil**  
Z = Single Circuit, A/C Scroll Compressor  
D = Dual Circuit, A/C Scroll Compressor

---

**Refrigerant Options**  
A = None<sup>1</sup>  
B = Low Ambient<sup>1</sup>  
T = Dual Circuit / Three Cooling Stages  
U = Dual Circuit / Three Cooling Stages with Low Ambient

---

**Nominal Tonnage**  
16 = 15 Tons  
25 = 20 Tons  
28 = 25 Tons<sup>2</sup>

---

**Not Used**  
A = Not Used

---

**Not Used**  
0 = Not Used

---

**Coil Options (RTPF)**  
A = Cu/Al  
B = Precoat (Cu/Al)  
C = E-Coat (Cu/Al)  
E = Cu/Cu  
M = Cu/Al with Louvered Hail Guard  
N = Precoat (Cu/Al) with Louvered Hail Guard  
P = E-Coat (Cu/Al) with Louvered Hail Guard  
R = Cu/Cu with Louvered Hail Guard

**Packaging**  
0 = Standard  
1 = LTL

---

**Electrical Options**  
A = None  
C = Non-Fused Disconnect

---

**Service Options**  
0 = None  
1 = Un-powered Convenience Outlet  
2 = Powered Convenience Outlet

---

**Not Used**  
A = Place Holder

---

**Base Unit Controls**  
0 = Electro-Mechanical Controls

---

**Design Rev**  
- = Initial Release

---

**Voltage**  
1 = 575/3/60  
5 = 208-230/3/60  
6 = 460/3/60

**Fig. 1 — Model Number Nomenclature**

POSITION NUMBER	1	2	3	4	5	6	7	8	9	10
TYPICAL	0	5	2	2	9	1	2	3	4	5

<p><b>POSITION</b></p> <p>1-2 3-4 5 6-10</p>	<p><b>DESIGNATES</b></p> <p>Week of manufacture (fiscal calendar) Year of manufacture ("23" = 2023) Manufacturing location Sequence number</p>
--	--

**Fig. 2 — Serial Number Nomenclature**

UNIT	ELECTRICAL CHARACTERISTICS	STD. UNIT WT.		CORNER A		CORNER B		CORNER C		CORNER D		CENTER OF GRAVITY			UNIT HEIGHT			
		LBS.	KG.	LBS.	KG.	LBS.	KG.	LBS.	KG.	LBS.	KG.	X	Y	Z	H			
38AUZ16 (RTPF)	208/230-3-60,460-3-60,575-3-60	731	332	237	107	172	78	135	61	186	84	38	[965.2]	19	[482.6]	17	[431.8]	50-3/8 [1279.2]
38AUD16 (RTPF)	208/230-3-60,460-3-60,575-3-60	731	332	237	107	172	78	135	61	186	84	38	[965.2]	19	[482.6]	17	[431.8]	50-3/8 [1279.2]



THIS DOCUMENT IS THE PROPERTY OF CARRIER CORPORATION AND IS DELIVERED UPON THE EXPRESS CONDITION THAT THE CONTENTS WILL NOT BE DISCLOSED OR USED WITHOUT CARRIER CORPORATION'S WRITTEN CONSENT.

SUBMISSION OF THESE DRAWINGS OR DOCUMENTS DOES NOT CONSTITUTE PART PERFORMANCE OR ACCEPTANCE OF CONTRACT.

- NOTES:
- MINIMUM CLEARANCE (LOCAL CODES OR JURISDICTION MAY PREVAIL):
    - BOTTOM TO COMBUSTIBLE SURFACES: 0 INCHES.
    - OUTDOOR COIL, FOR PROPER AIR FLOW: 36 INCHES ONE SIDE, 12 INCHES THE OTHER. THE SIDE GETTING THE GREATER CLEARANCE IS OPTIONAL.
    - OVERHEAD: 60 INCHES, TO ASSURE PROPER OUTDOOR FAN OPERATION.
    - BETWEEN UNITS: CONTROL BOX SIDE, 42 INCHES PER NEC.
    - BETWEEN UNIT AND UNGROUNDED SURFACES: CONTROL BOX SIDE: 36 INCHES PER NEC.
    - BETWEEN UNIT AND BLOCK OR CONCRETE WALLS AND OTHER GROUNDED SURFACES: CONTROL BOX SIDE, 42 INCHES PER NEC.
  - WITH EXCEPTION OF THE CLEARANCE FOR THE OUTDOOR COIL AS STATED IN NOTE 1B, A REMOVABLE FENCE OR BARRICADE REQUIRES NO CLEARANCE.
  - UNITS MAY BE INSTALLED ON COMBUSTIBLE FLOORS MADE FROM WOOD OR CLASS A, B OR C ROOF COVERING MATERIAL.

SERVICE VALVE CONNECTIONS			
UNIT	SUCTION	LIQUID	QTY
38AUZ16	1-3/8 [34.9]	5/8 [15.9]	1 EA
38AUD16	1-3/8 [34.9]	1/2 [12.7]	2 EA

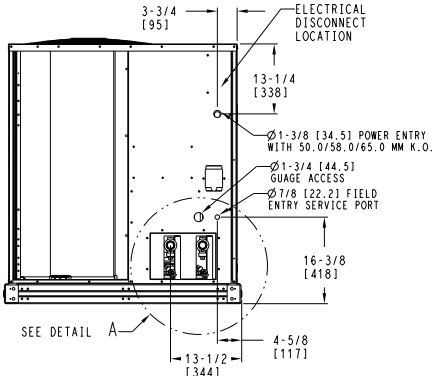
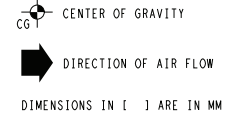

LEFT SIDE VIEW FOR 38AUD SYSTEMS

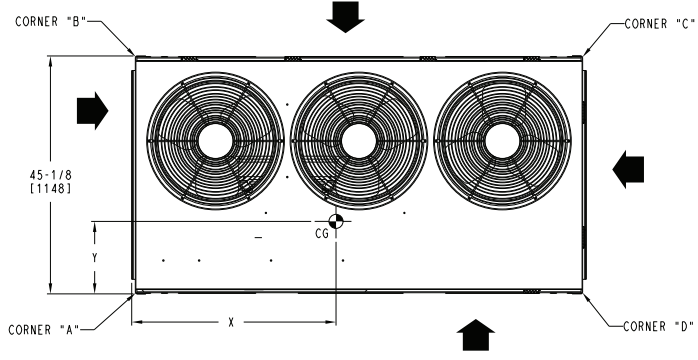

TOP VIEW

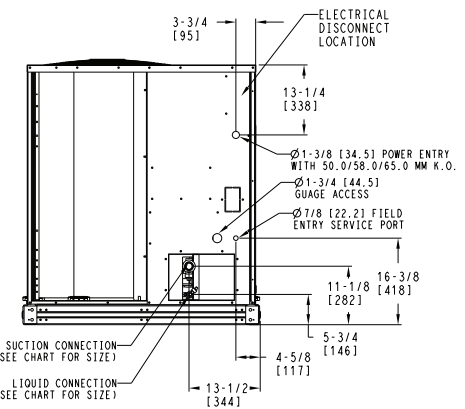

LEFT SIDE VIEW

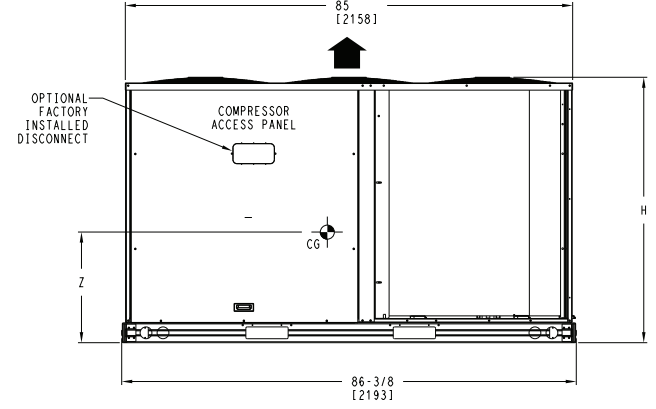

FRONT VIEW

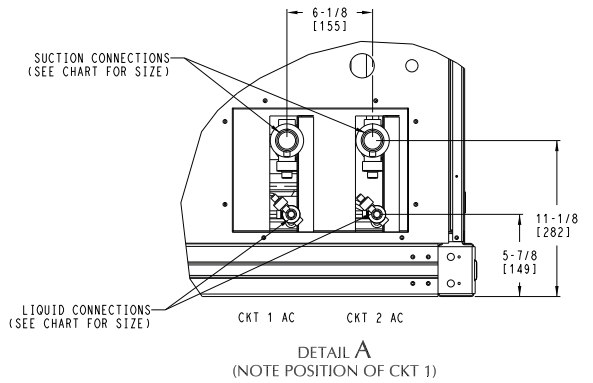

DETAIL A (NOTE POSITION OF CKT 1)

ITC CLASSIFICATION	SHEET	DATE	SUPERCEDES	38AUZ, 38AUD CONDENSING UNIT	38AU500503	REV
U.S. ECCN:NSR	1 OF 1	02/07/22	05/08/19			H

Fig. 3 — 38AUD/Z 16 Base Unit Dimensions

UNIT	ELECTRICAL CHARACTERISTICS	STD. UNIT WT.		CORNER A		CORNER B		CORNER C		CORNER D		CENTER OF GRAVITY			UNIT HEIGHT	
		LBS.	KG.	LBS.	KG.	LBS.	KG.	LBS.	KG.	LBS.	KG.	X	Y	Z	H	
38AUZ25 (RTPF)	208/230-3-60,460-3-60,575-3-60	978	444	360	163	188	85	147	67	283	128	38 [965.2]	23 [584.2]	17 [431.8]	50-3/8 [1279.2]	
38AUD25 (RTPF)	208/230-3-60,460-3-60,575-3-60	978	444	360	163	188	85	147	67	283	128	38 [965.2]	23 [584.2]	17 [431.8]	50-3/8 [1279.2]	
38AUD28 (RTPF)	208/230-3-60,460-3-60,575-3-60	978	444	327	148	210	95	173	78	269	122	39 [990.6]	26.25 [666.8]	17 [431.8]	50-3/8 [1279.2]	

**Carrier** THIS DOCUMENT IS THE PROPERTY OF CARRIER CORPORATION AND IS DELIVERED UPON THE EXPRESS CONDITION THAT THE CONTENTS WILL NOT BE DISCLOSED OR USED WITHOUT CARRIER CORPORATION'S WRITTEN CONSENT. SUBMISSION OF THESE DRAWINGS OR DOCUMENTS DOES NOT CONSTITUTE PART PERFORMANCE OR ACCEPTANCE OF CONTRACT.

- NOTES:
- MINIMUM CLEARANCE (LOCAL CODES OR JURISDICTION MAY PREVAIL):
    - BOTTOM TO COMBUSTIBLE SURFACES: 0 INCHES.
    - OUTDOOR COIL, FOR PROPER AIR FLOW: 36 INCHES ONE SIDE, 12 INCHES THE OTHER. THE SIDE GETTING THE GREATER CLEARANCE IS OPTIONAL.
    - OVERHEAD: 60 INCHES, TO ASSURE PROPER OUTDOOR FAN OPERATION.
    - BETWEEN UNITS: CONTROL BOX SIDE, 42 INCHES PER NEC.
    - BETWEEN UNIT AND UNGROUNDED SURFACES: CONTROL BOX SIDE, 36 INCHES PER NEC.
    - BETWEEN UNIT AND BLOCK OR CONCRETE WALLS AND OTHER GROUNDED SURFACES: CONTROL BOX SIDE, 42 INCHES PER NEC.
  - WITH EXCEPTION OF THE CLEARANCE FOR THE OUTDOOR COIL AS STATED IN NOTE 1B, A REMOVABLE FENCE OR BARRICADE REQUIRES NO CLEARANCE.
  - UNITS MAY BE INSTALLED ON COMBUSTIBLE FLOORS MADE FROM WOOD OR CLASS A, B OR C ROOF COVERING MATERIAL.

UNIT	SERVICE VALVE CONNECTIONS		QTY
	SUCTION	LIQUID	
38AUZ25	1-5/8 [41.3]	5/8 [15.9]	1 EA
38AUD25	1-3/8 [34.9]	1/2 [12.7]	2 EA

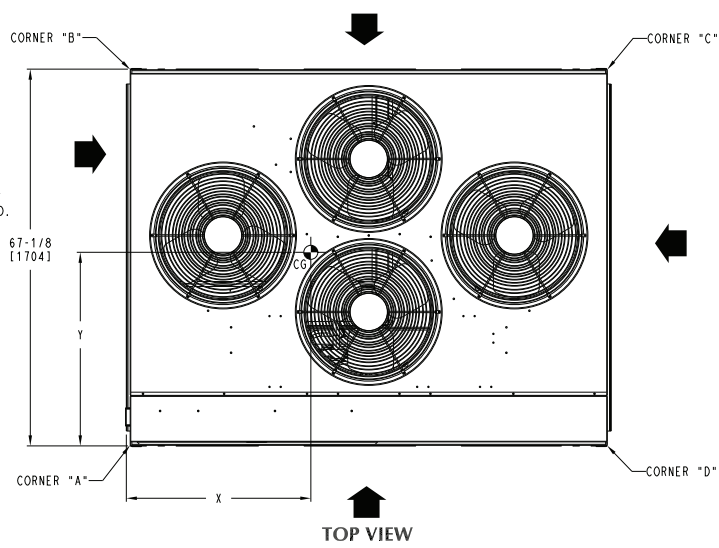
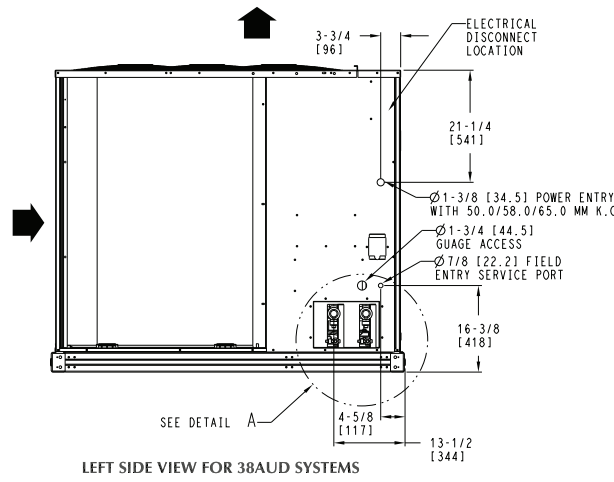

CG CENTER OF GRAVITY  
 → DIRECTION OF AIR FLOW  
 DIMENSIONS IN [ ] ARE IN MM

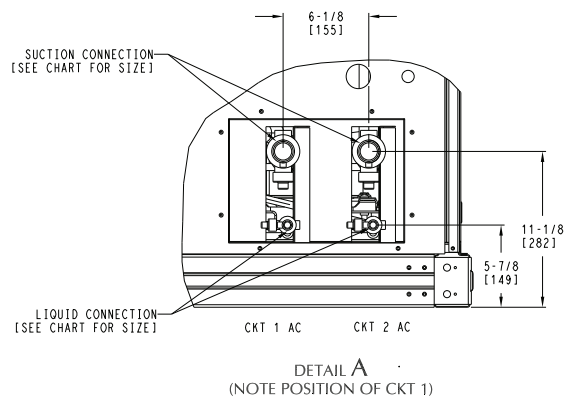
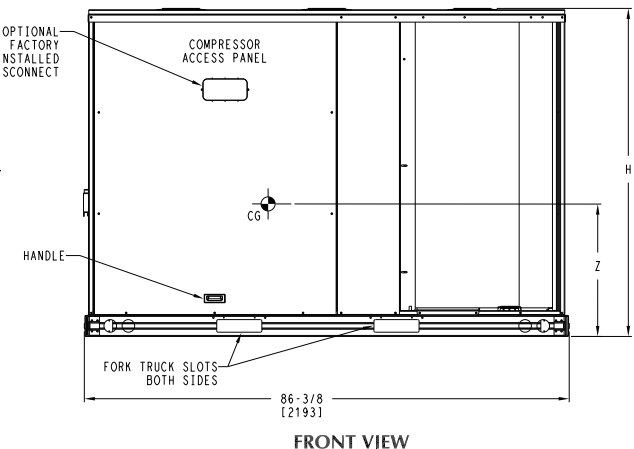
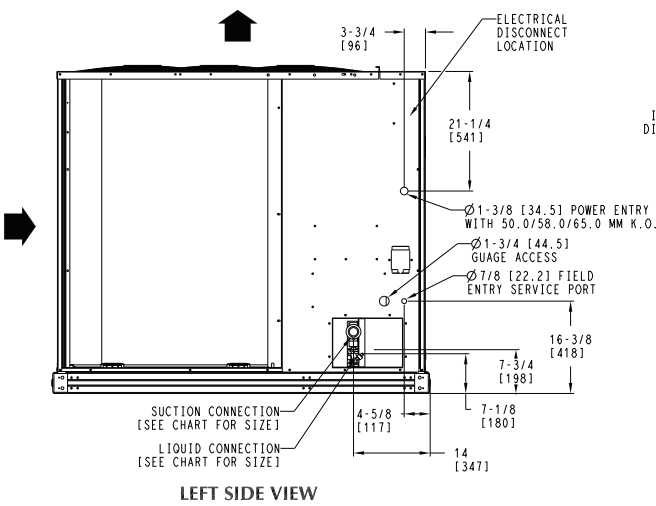

DATE 9/1/22	SUPERCEDES 11/17/10	38AUZ , 38AUD CONDENSING UNIT	38AU500370	F
----------------	------------------------	-------------------------------	------------	---

Fig. 4 — 38AUZ 25 / 38AUD 25-28 Base Unit Dimensions

**Table 4 — 38AUZ\*16-25 Physical Data**

UNIT	38AUZ(A,B)16	38AUZ(A,B)25
NOMINAL CAPACITY (TONS)	15	20
OPERATING WEIGHT (LB)	731	978
<b>REFRIGERATION SYSTEM</b>		
# Circuits / # Comp. / Type	1 / 2 / Scroll	1 / 2 / Scroll
Refrigerant Type	R-410A	R-410A
R-410A Shipping Charge A/B (lb)	9.0	9.0
System Charge w/ Fan Coil <sup>a</sup>	43.0	38.0
Metering Device	TXV	TXV
High-press. Trip / Reset (psig)	630 / 505	630 / 505
Low-press. Trip / Reset (psig)	54 / 117	54 / 117
<b>COMPRESSOR</b>		
Oil Charge A/B (oz)	60 / 60	110 / 110
Speed (rpm, 60/50 Hz)	3500	3500
<b>CONDENSER COIL</b>		
Material	Al/Cu	Al/Cu
Coil Type	RTPF	RTPF
Rows / FPI	2 / 17	2 / 17
Total Face Area (ft <sup>2</sup> )	23.5 x 2	25.0 x 2
<b>CONDENSER FAN / MOTOR</b>		
Qty / Motor Drive Type	3 / direct	4 / direct
Motor HP / RPM	1/4 / 1100	1/4 / 1100
Fan Diameter (in.)	22	22
Nominal Airflow (cfm)	9,000	12,000
Watts (total)	970	1150
<b>PIPING CONNECTIONS</b>		
Qty / Suction (in. ODS)	1 / 1-3/8	1 / 1-5/8
Qty / Liquid (in. ODS)	1 / 5/8	1 / 5/8

NOTE(S):

- a. Approximate system charge with about 25 ft piping of sizes indicated with matched 40RU.

**Table 5 — 38AUD\*16-28 Physical Data**

UNIT	38AUD(T,U)16	38AUD(T,U)25	38AUD(T,U)28
NOMINAL CAPACITY (TONS)	15	20	25
OPERATING WEIGHT (LB)	731	978	978
<b>REFRIGERATION SYSTEM</b>			
# Circuits / # Comp. / Type	2 / 2 / Scroll	2 / 2 / Scroll	2 / 2 / Scroll
Refrigerant Type	R-410A	R-410A	R-410A
R-410A Shipping Charge A/B (lb)	9.0 / 9.0	9.0 / 9.0	9.0 / 9.0
System Charge w/ Fan Coil <sup>a</sup>	20.4 / 22.4	20.90 / 20.55	24.17 / 25.80
Metering Device	TXV	TXV	TXV
High-press. Trip / Reset (psig)	630 / 505	630 / 505	630 / 505
Low-press. Trip / Reset (psig)	54 / 117	54 / 117	54 / 117
<b>COMPRESSOR</b>			
Oil Charge A/B (oz)	60 / 60	110 / 110	110 / 110
Speed (rpm, 60/50 Hz)	3500 / 2900	3500 / 2900	3500 / 2900
<b>CONDENSER COIL</b>			
Material	Al/Cu	Al/Cu	Al/Cu
Coil Type	RTPF	RTPF	RTPF
Rows / FPI	2 / 17	2 / 17	2 / 17
Total Face Area (ft <sup>2</sup> )	23.5 x 2	25.0 x 2	25.0 x 2
<b>CONDENSER FAN / MOTOR</b>			
Qty / Motor Drive Type	3 / direct	4 / direct	4 / direct
Motor HP / RPM	1/4 / 1100	1/4 / 1100	1/4 / 1100
Fan Diameter (in.)	22	22	22
Nominal Airflow (cfm)	9,000	12,000	12,000
Watts (total)	970	1150	1150
<b>PIPING CONNECTIONS</b>			
Qty / Suction (in. ODS)	2 / 1-3/8	2 / 1-3/8	2 / 1-3/8
Qty / Liquid (in. ODS)	2 / 1/2	2 / 1/2	2 / 1/2

NOTE(S):

- a. Approximate system charge with about 25 ft piping of sizes indicated with matched 40RU.



## INSTALLATION

### Jobsite Survey

Complete the following checks before installation.

1. Consult local building codes and the NEC (National Electrical Code) ANSI/NFPA 70 for special installation requirements.
2. Determine unit location (from project plans) or select unit location.
3. Check for possible overhead obstructions which may interfere with unit lifting or rigging.

### Step 1 — Plan for Unit Location

The 38AU units are designed and approved for outdoor installation only. Do not locate these units indoors. Do not add ducting to unit fan system.

Select a location for the unit and its support system (pad, rails or other) that provides for the minimum clearances required for safety. This includes the clearance to combustible surfaces, unit performance and service access below, around and above unit as specified in unit drawings. See Fig. 5.

NOTE: Local codes may require different clearances than specified in Fig. 5. It is the responsibility of installers to be knowledgeable in local codes and to modify the recommended clearances to satisfy local codes.

NOTE: Consider also the effect of adjacent units on airflow performance and control box safety clearance.

Do not install the outdoor unit in an area where fresh air supply to the outdoor coil may be restricted or when recirculation from the condenser fan discharge is possible. Do not locate the unit in a well or next to high walls.

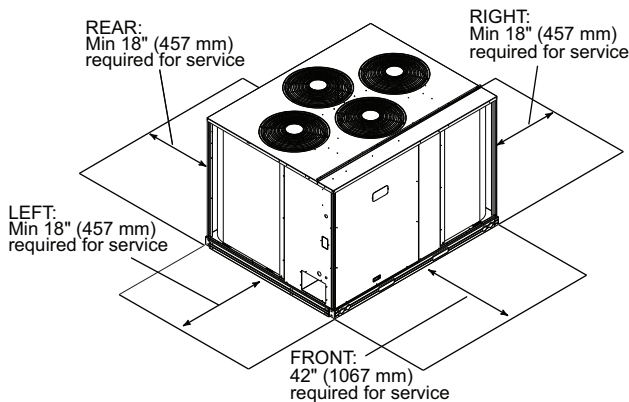

NOTE: Observe requirements for 39" (914 mm) operating clearance on either Left or Rear coil opening.

**Fig. 5 — Service Clearance Dimensional Drawing**

Evaluate the path and required line length for interconnecting refrigeration piping, including suction riser requirements (outdoor unit above indoor unit) and liquid line lift (outdoor unit below indoor unit) Relocate sections to minimize the length of interconnecting tubing.

**IMPORTANT: DO NOT BURY REFRIGERANT LINES.**

Although unit is weatherproof, avoid locations that permit water from higher level runoff and overhangs to fall onto the unit.

### Step 2 — Complete Pre-Installation Checks

#### CHECK UNIT ELECTRICAL CHARACTERISTICS

Confirm before installation of unit that voltage, amperage and circuit protection requirements listed on unit data plate agree with power supply provided.

### UN-CRATE UNIT

Remove unit packaging except for the top skid assembly, which should be left in place until after the unit is rigged into its final location.

### INSPECT SHIPMENT

File a claim with shipping company if the shipment is damaged or incomplete.

### CONSIDER SYSTEM REQUIREMENTS

Consult local building codes and National Electrical Code (NEC, U.S.A.) for special installation requirements.

Allow sufficient space for airflow clearance, wiring, refrigerant piping, and servicing unit. See Fig. 3 and 4 for unit dimensions and weight distribution data.

Locate the unit so that the outdoor coil (condenser) airflow is unrestricted on all sides and above.

The unit may be mounted on a level pad directly on the base channels or mounted on raised pads at support points. See Fig. 3 and 4 for weight distribution based on recommended support points.

NOTE: If vibration isolators are required for a particular installation, use the weight distribution data in Fig. 3 and 4 to make the proper selection.

### Step 3 — Prepare Unit Mounting Support

#### SLAB MOUNT

Provide a level concrete slab that extends a minimum of 6 in. (150 mm) beyond unit cabinet. Install a gravel apron in front of condenser coil air inlet to prevent grass and foliage from obstructing airflow.

### Step 4 — Rig and Mount the Unit

#### ⚠ CAUTION

#### UNIT DAMAGE HAZARD

Failure to follow this caution may result in equipment damage.

All panels must be in place when rigging. Unit is not designed for handling by fork truck when packaging is removed.

If using top crate as spreader bar, once unit is set, carefully lower wooden crate off building roof top to ground. Ensure that no people or obstructions are below prior to lowering the crate.

#### RIGGING

These units are designed for overhead rigging. Refer to the rigging label for preferred rigging method. Spreader bars are not required if top crating is left on the unit. All panels must be in place when rigging. As further protection for coil faces, plywood sheets may be placed against the sides of the unit, behind cables. Run cables to a central suspension point so that the angle from the horizontal is not less than 45 degrees. Raise and set the unit down carefully.

If it is necessary to roll the unit into position, mount the unit on longitudinal rails, using a minimum of 3 rollers. Apply force to the rails, not the unit. If the unit is to be skidded into position, place it on a large pad and drag it by the pad. Do not apply any force to the unit.

Raise from above to lift the unit from the rails or pad when unit is in its final position.

After the unit is in position, remove all shipping materials and top crating.

### Step 5 — Determine Refrigerant Line Sizes

Select the recommended line sizes for 38AUZ and 38AUD unit from the appropriate tables.

Determine the linear length of interconnecting piping required between the outdoor unit and indoor unit (evaporator). Consider and identify also the arrangement of the tubing path (quantity and type of elbows in both lines), liquid line solenoid size, filter drier and any other refrigeration specialties located in the liquid line. Refer to the indoor unit installation instructions for additional details on refrigeration specialties devices.

Determine equivalent line length adjustments for path and components and add to linear line lengths. See Table 6, Equivalent Lengths for Common Fittings, for usual fitting types. Also identify adjustments for refrigeration specialties. Refer to Part 3 of the Carrier System Design Manual for additional data and information on equivalent lengths.

**Table 6 — Equivalent Lengths for Common Fittings (ft)**

NOMINAL TUBE OD (in.)	ELBOWS				
	90° Std	90° Lrad	90° Street	90° Std	90° Street
3/8	1.3	0.8	2.2	0.6	1.0
1/2	1.4	0.9	2.3	0.7	1.1
5/8	1.6	1.0	2.5	0.8	1.3
3/4	1.8	1.2	2.9	0.9	1.5
7/8	2.0	1.4	3.2	0.9	1.6
1-1/8	2.6	1.7	4.1	1.3	2.1
1-3/8	3.3	2.3	5.6	1.7	3.0
1-5/8	4.0	2.6	6.3	2.1	3.4
2-1/8	5.0	3.3	8.2	2.6	4.5

NOMINAL TUBE OD (in.)	TEES			
	Branch Flow	Straight-Thru		
		No Reduct	Reduce 25%	Reduce 50%
3/8	2.6	0.8	1.1	1.3
1/2	2.7	0.9	1.2	1.4
5/8	3.0	1.0	1.4	1.6
3/4	3.5	1.2	1.7	1.8
7/8	4.0	1.4	1.9	2.0
1-1/8	5.0	1.7	2.3	2.6
1-3/8	7.0	2.3	3.1	3.3
1-5/8	8.0	2.6	3.7	4.0
2-1/8	10.0	3.3	4.7	5.0

NOTE: Equivalent line lengths will vary based on tube diameter. Calculate equivalent line length for each pipe by adding equivalent length adjustments to linear lengths for each pipe.

Enter the appropriate table to select the recommended line sizes.

MODEL NUMBER POSITION #6	TABLE	QUANTITY OF LINE SETS
38AUZ	7	1
38AUD	8	2

#### LIQUID LIFT

A liquid lift condition exists when the outdoor unit is located below the indoor (evaporator) unit and liquid flows vertically up in a portion of the liquid line. The vertical column of liquid reduces the available state point sub-cooling at the evaporator coil's thermal expansion valve. This effect reduces the length of liquid lift (feet of elevation) that a liquid line size can accommodate. Longer linear tube lengths will also reduce the amount of liquid lift possible.

Check Tables 7 (38AUZ) and 8 (38AUD), for maximum liquid lift capabilities for line sizes. Note for size 16 that condenser coil type also effects maximum liquid lift; ensure the lines for this unit's specific coil type are being used.

Reselect the liquid line tube size if necessary. If maximum available tube size cannot provide the required lift distance on this installation, relocate the outdoor unit to reduce the equivalent line length or the lift requirement.



**Table 7 — 38AUZ\_16-25 Piping Recommendations (Single-Circuit)**

MODEL & NOMINAL CAPACITY	LINEAR LINE (FT)	0 - 24	25 - 49	50 - 74	75 - 99	100 - 124	125 - 149	150 - 174	175 - 200						
	EQUIV. LINE (FT)	0 - 37	38 - 74	75 - 112	113 - 149	150 - 187	188 - 224	225 - 262	263 - 300						
38AUZ_16 TC 185.7, SC 18.4°F	Liquid Line Size (in.)	5/8	5/8	5/8	5/8	5/8	5/8	5/8	3/4	5/8	3/4				
	Liquid PD (F)	0.7	1.3	2.0	2.7	3.4	4.0	4.7	2.5	5.4	2.8				
	Max Lift (ft)	25	50	75	100	125	150	153	175	145	175				
	Max Lift PD (F)	2.8	5.65	8.5	11.3	14.1	16.9	17.9	17.5	17.9	17.9				
	Suction Line Size (in.)	1-3/8	1-3/8	1-3/8	1-3/8	1-3/8	1-5/8	1-3/8	1-5/8	1-3/8	1-5/8				
	Suction Line PD (F) (Cap Red)	1.4	1.0	1.5	2.0	2.5 (-0.9%)	1.1	3 (-1.8%)	1.3	3.5 (-2.7%)	1.5	4 (-3.6%)			
	Charge (lb)	35.1	38.1	41.2	44.2	47.3	48.4	50.4	51.7	53.4	63.7	56.5	68.3		
	#/TR	2.9	3.11	3.36	3.61	3.86	3.95	4.11	4.22	4.36	5.20	4.61	5.57		
	38AUZ_25 TC 233.3, SC 13.0°F	Liquid Line Size (in.)	5/8	5/8	5/8	5/8	5/8	3/4	5/8	3/4	5/8	3/4	5/8	3/4	
		Liquid PD (F)	1.1	2.1	3.2	4.3	5.4	2.8	6.4	3.3	7.5	3.9	8.6	4.4	
Max Lift (ft)		25	50	93	98	85	116	71	108	59	102	46	95		
Max Lift PD (F)		3.2	6.4	9.6	12.5	12.5	12.5	12.4	12.5	12.5	12.5	12.5	12.5		
Suction Line Size (in.)		1-3/8	1-3/8	1-3/8	1-5/8	1-3/8	1-5/8	1-3/8	1-5/8	1-5/8	2-1/8	1-5/8	2-1/8	1-5/8	2-1/8
Suction Line PD (F) (Cap Red)		0.8	1.6	2.4 (-0.8%)	1.0	3.3 (-2.2%)	1.4	4 (-3.6%)	1.7	2.0	0.4	2.4 (-0.7%)	0.5	2.7 (-1.2%)	0.6
Charge (lb)		31.1	34.1	37.2	37.9	40.2	41.1	43.3	50.7	47.7	58.5	51.0	63.6	54.3	68.7
#/TR		2.52	2.77	3.02	3.07	3.26	3.34	3.51	4.11	3.87	4.75	4.13	5.16	4.40	5.57

LEGEND

- #/TR — Charge to unit capacity ratio, lb per ton (at 45°F SST, 95°F OAT)
- Cap Red — Capacity reduction caused by suction line pressure drop > 2°F
- Liquid PD (F) — Liquid line pressure drop, saturated temperature, °F
- Max Lift — Maximum liquid lift (Indoor unit ABOVE outdoor unit only), at maximum permitted pressure drop.
- Max Lift PD (F) — Pressure drop including Maximum liquid lift value
- SC — Sub-cooling, °F (at liquid line valve)
- Suction Line PD (F) — Suction line pressure drop, saturated temperature, °F
- TC — Total Capacity, MBH (at 45°F Saturated suction, 95°F outdoor air temperature)

**Table 8 — 38AUD\_16-28 Piping Recommendations (Dual-Circuit)<sup>a</sup>**

MODEL & NOMINAL CAPACITY	LINEAR LINE (FT)	0 - 24	25 - 49	50 - 74		75 - 99		100 - 124		125 - 149		150 - 174		175 - 200		
	EQUIV. LINE (FT)	0 - 37	38 - 74	75 - 112		113 - 149		150 - 187		188 - 224		225 - 262		263 - 300		
38AUD_16 TC 92.9 Each, SC 15.1°F	Liquid Line Size (in.)	3/8	3/8	3/8	1/2	1/2		1/2		1/2	5/8	1/2	5/8	1/2	5/8	
	Liquid PD (F)	3.4	6.9	10.3	1.9	2.6		3.2		3.9	1.0	4.5	1.2	5.1	1.4	
	Max Lift (ft)	25	50	32	75	144		125		127	150	121	159	112	157	
	Max Lift PD (F)	5.5	11.1	13.0	8.2	10.9		13.7		14.5	13.6	14.5	14.5	14.5	14.5	
	Suction Line Size (in.)	1-3/8	1-3/8	1-1/8		1-1/8		1-1/8	1-3/8	1-1/8	1-3/8	1-1/8	1-3/8	1-1/8		
	Suction Line PD (F) (Cap Red)	0.5	0.1	1.2		1.6		2 (-0.1%)	0.7	2.5 (-0.8%)	0.8	2.9 (-1.5%)	1.0	3.3 (-2.2%)	1.1	
	Charge (lb)	22.6	23.9	19.5	21.8	23.7		25.7	26.6	27.6	34.4	29.5	37.4	31.5	40.5	
	#/TR	1.42	1.50	1.55	1.73	1.89		2.04	2.11	2.19	2.73	2.35	2.97	2.50	3.22	
38AUD_25 TC 121.2 Each, SC 10.6°F	Liquid Line Size (in.)	3/8	1/2	1/2	5/8	1/2	5/8	1/2	5/8	1/2	5/8	5/8		5/8	3/4	
	Liquid PD (F)	5.6	2.2	3.3	0.9	4.3	1.2	5.4	1.5	6.5	1.8	2.1		2.4	1.3	
	Max Lift (ft)	25	50	64	75	70	108	55	104	42	100	97		92	107	
	Max Lift PD (F)	7.7	6.3	8.5	7.1	10.0	9.4	9.9	10.0	10.0	10.0	10.0		9.9	10.0	
	Suction Line Size (in.)	1-1/8	1-1/8	1-1/8	1-3/8	1-1/8	1-3/8	1-1/8	1-3/8	1-3/8		1-3/8		1-3/8		
	Suction Line PD (F) (Cap Red)	0.7	1.3	2.0	0.7	2.7 (-1.2%)	1.0	3.4 (-2.4%)	1.2	1.4		1.7		1.9		
	Charge (lb)	15.2	17.9	19.8	23.2	21.7	26.2	23.7	29.3	26.7	32.4	35.4		38.5	48.5	
	#/TR	1.20	1.41	1.56	1.83	1.72	2.07	1.87	2.31	2.11	2.56	2.80		3.04	3.83	
38AUD_28 TC 281.9 Each, SC 13.9°F	Liquid Line Size (in.)	1/2	1/2	5/8	5/8	3/4	5/8	3/4	5/8	3/4	3/4	7/8	3/4	7/8	3/4	7/8
	Liquid PD (F)	4.2	8.5	3.0	4.6	2.4	6.1	3.2	7.7	4.0	4.8	1.5	5.6	1.8	6.4	2.1
	Max Lift (ft)	25	14	50	48	75	42	79	23	69	59	99	49	96	39	93
	Max Lift PD (F)	6.3	9.6	7.1	8.4	8.4	9.5	9.5	9.5	9.5	9.5	9.5	9.5	9.5	9.5	9.5
	Suction Line Size (in.)	1-1/8	1-3/8	1-5/8	1-3/8	1-5/8	1-5/8		1-5/8		1-5/8		1-5/8		2-1/8	
	Suction Line PD (F) (Cap Red)	4.2 (-4.0%)	2.8 (-1.6%)	1.2	4.3 (-4.2%)	1.8	2.4		3.0 (-1.9%)		3.6 (-2.9%)		4.2 (-4.0%)		1.9	
	Charge (lb)	25.8	28.1	30.4	33.7	39.1	39.2	44.2	43.1	49.3	54.4	63.3	59.5	69.8	64.6	76.4
	#/TR	1.10	1.20	1.30	1.44	1.67	1.67	1.88	1.83	2.10	2.32	2.69	2.53	2.97	2.75	3.25

NOTE(S):

a. 38AUD units require TWO sets of refrigeration piping.

LEGEND

- #/TR — Charge to unit capacity ratio, lb per ton (at 45°F SST, 95°F OAT)
- Cap Red — Capacity reduction caused by suction line pressure drop > 2°F
- Liquid PD (F) — Liquid line pressure drop, saturated temperature, °F
- Max Lift — Maximum liquid lift (Indoor unit ABOVE outdoor unit only), at maximum permitted pressure drop.
- Max Lift PD (F) — Pressure drop including Maximum liquid lift value
- SC — Sub-cooling, °F (at liquid line valve)
- Suction Line PD (F) — Suction line pressure drop, saturated temperature, °F
- TC — Total Capacity, MBH (at 45°F Saturated suction, 95°F outdoor air temperature)

## Suction Riser

A suction riser condition exists when the outdoor unit is located above the indoor (evaporator) unit and suction vapor must flow vertically up to return to the compressor. Oil return is a concern when the suction tube size is too large to produce the minimum refrigerant velocity to ensure oil return at minimum load conditions.

### 38AUZ AND 38AUD

Check Table 9 for maximum suction tube size for 38AU units at minimum load conditions. Consider suction speed riser (reduced tube size for vertical segment only) or double suction riser arrangement if the planned suction tube size does not provide necessary minimum flow-rates for this riser.

**Table 9 — 38AU Maximum Suction Pipe Size**

MODEL	UNIT SIZE	MAXIMUM TUBE SIZE (in.)
38AUZ	16-25	1-5/8
38AUD	16-28	1-5/8

### Outdoor Unit ABOVE Evaporator Coil

This installation will have at least one suction riser segment. If the vertical elevation difference is less than 20-ft (6.1 m) linear feet and requires only one or two segments, consider a speed riser selection for Circuit 1; use the line marked VAPOR RISER REQUIRED; NOT GREATER THAN 20 FT (6.1 M). See Fig. 6. Tube S is the horizontal line size; tube A is the reduced diameter riser size.

If the vertical elevation difference is greater than 20-ft (6.1-m) linear feet or requires more than two short lift segments, select the Circuit 1 suction line size from Double Suction Riser lines data under VAPOR RISER GREATER THAN 20 FT (6.1 M). See Fig. 7. Tube S is the horizontal line size. Tube A is the reduced diameter riser size without bottom trap; Tube B is the parallel riser size with bottom oil trap.

### Outdoor Unit BELOW Evaporator Coil and No Vertical Riser Segments

Select Circuit 1 suction line size from NO VAPOR RISER line.

### Circuit 2 Suction Line

No special riser selections are necessary.

### Vertical Separation (outdoor unit above indoor unit)

Vertical elevation difference of 200 ft (60 m) is permitted when the outdoor unit (38AUZ or 38AUD) is located above the indoor unit.

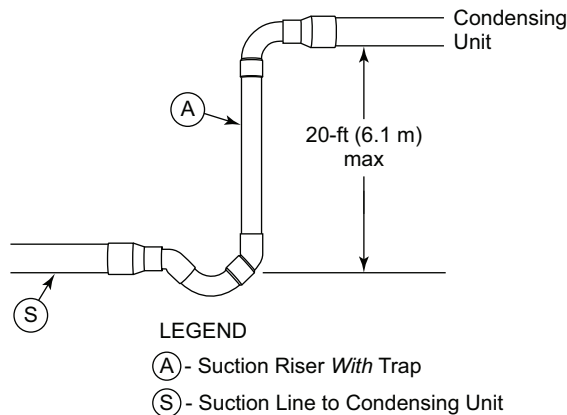

**Fig. 6 — Suction Line Piping - Speed Riser**

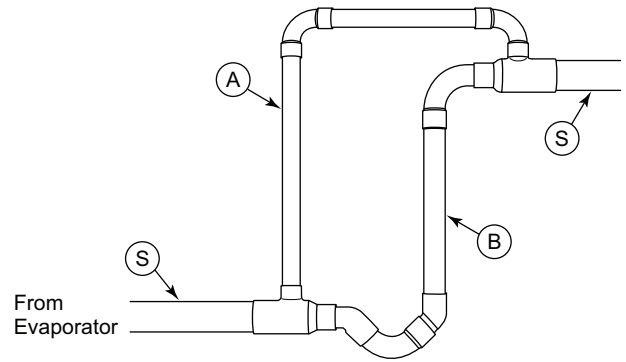

### LEGEND

- (A) - Suction Riser Without Trap
- (B) - Suction Riser With Trap
- (S) - Suction Line to Condensing Unit

**Fig. 7 — Suction Line Piping - Double Riser**

## Step 6 — Complete Refrigerant Piping Connections

**IMPORTANT: DO NOT BURY REFRIGERANT LINES.**

**IMPORTANT: A refrigerant receiver is not provided with the unit. Do not install a receiver.**

### PROVIDE SAFETY RELIEF

If local codes dictate an additional safety relief device, purchase locally and install locally. Installation will require the recovery of the factory shipping charge before the factory tubing can be cut and the supplemental relief device is installed.

Model 38AUD has two separate refrigeration systems. If required, each circuit will require a field-supplied/installed supplemental relief device.

### CHECK 38AU MODEL WITH EVAPORATOR COIL CONNECTIONS

Confirm before installation of unit that the evaporator coil connections are consistent with this 38AU model. See Table 3 on page 3.

### INSULATE SUCTION LINES

Apply closed-cell tubular insulation to all suction lines between evaporator coil connection and 38AU unit's suction service valve.

### 38AUD PIPING CONNECTIONS

The 38AUD unit's two circuits are designated Circuit 1 and Circuit 2. Circuit 1 is controlled by the thermostat's Y1 (or TC1) contact and will be the first circuit on and last circuit off. Circuit 2 is controlled by the thermostat's Y2 (or TC2) contact and this circuit is always the "lag" circuit.

See Fig. 8 for location of Circuit 1 and Circuit 2 service valves and field piping connections. Circuit 1 is on the right-hand side of the service valve compartment; Circuit 2 is on the left.

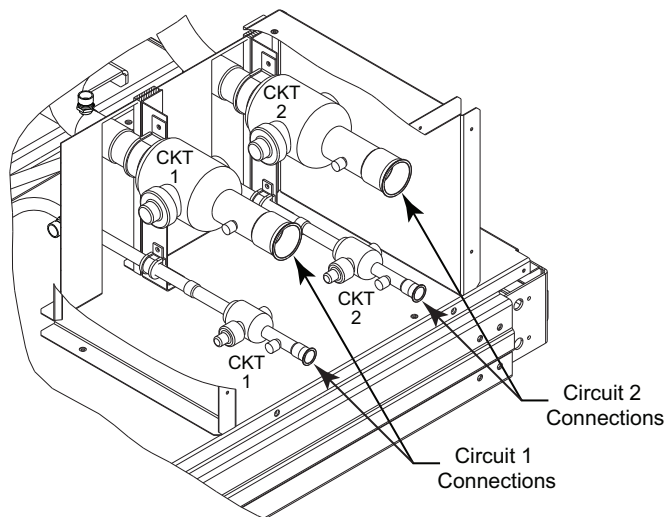

**Fig. 8 — 38AUD Service Valve Locations**

When a single piece evaporator coil with two separate circuits is connected to a 38AUD, the lower coil circuit should be connected to the 38AUD unit's Circuit 1 so that the evaporator's lower coil segment is first-on/last-off (to avoid re-evaporation of condensate on dry lower coil segments).

Plan the Circuit 1 and Circuit 2 tubing segments carefully, mark each segment and check constantly as piping systems are assembled to avoid piping errors.

The 38AUD unit cannot be field-piped as a single-circuit/tandem system.

**FINAL TUBING CHECK — 38AUD**

Before completing the field piping connections to the 38AUD unit service valves, confirm that the suction line to the indoor coil's first-on/last-off circuit (and its companion liquid line) are correctly identified as Circuit 1 use for the 38AUD unit. If a suction riser is required, it must be in Circuit 1.

**Connecting 40RU to 38AUD**

The 40RU fan coil in sizes 16, 25 and 28 is a face-split coil design that also has its circuits designated as 1 and 2. See Table 10 and Fig. 9. Note that the lower coil segment changes as the arrangement of the 40RU changes. In a vertical arrangement, the 40RU unit's lower coil segment is segment 2; this segment should be connected to the 38AUD unit's Circuit 1. In a horizontal arrangement, the 40RU unit's lower segment is now segment 1; this segment should be connected to the 38AUD unit's Circuit 1.

Note that refrigerant suction piping should be insulated.

**Table 10 — 40RU Arrangement Details**

40RU ARRANGEMENT	COOLING STAGE	40RU COIL SEGMENT	CONNECT TO 38AUD
Vertical	Y1	2	Circuit 1
	Y2	1	Circuit 2
Horizontal	Y1	1	Circuit 1
	Y2	2	Circuit 2

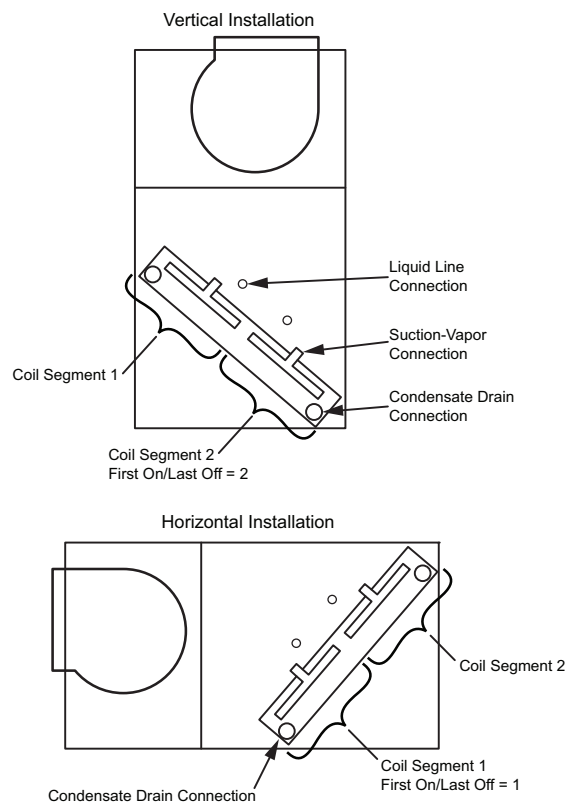

**Fig. 9 — Typical Evaporator Coil Connections (40RU)**

**INSTALL FILTER DRIER(S) AND MOISTURE INDICATOR(S)**

Every unit MUST have a filter drier in the liquid line. 38AUD models require two filter driers (one in each liquid line). Locate the filter drier(s) at the indoor unit, close to the evaporator coil's thermal expansion valve (TXV) inlets.

The 38AU units include one (38AUZ) or two (38AUD) Puron-duty filter drier(s), shipped in cartons attached to the unit basepan (see Table 11). Remove the filter drier(s) and prepare to install in the liquid line(s) at the evaporator coil. Do not remove connection fitting plugs until ready to connect and braze the filter drier into the liquid line position.

Installation of liquid line moisture indicating sight glass in each circuit is recommended. Locate the sight glass(es) between the outlet of the filter drier and the TXV inlet.

Refer to Table 12 for recommendations on refrigeration specialties.

**Table 11 — Puron-duty Filter Drier(s)**

MODEL SIZE	QTY	LIQUID LINE OD (in.)	DESICCANT VOLUME	PART NUMBER REF.
38AUZ*16	1	5/8	30 cu in.	KH43LS087
38AUZ*25	1	5/8	30 cu in.	KH43LS087
38AUD*16	2	1/2	8 cu in.	KH43LS085
38AUD*25	2	1/2	16 cu in.	KH43LS085
38AUD*28	1	1/2	16 cu in.	KH43LS085

**Table 12 — Refrigerant Specialties Part Numbers**

MODEL	SIZES	LIQUID LINE SIZE (in.)	LIQUID LINE SOLENOID VALVE (LLSV)	LLSV COIL	SIGHT GLASS	FILTER DRIER
38AUD <sup>a</sup>	16-28	1/2	EF680035	EF680037	KM680004	Provided with unit, see Table 11
		5/8	EF680036	EF680037	KM680005	
38AUZ	16-25	5/8	EF680036	EF680037	KM680005	

NOTE(S):

a. 38AUD units require TWO sets of parts.

In some applications, depending on space and convenience requirements, it may be desirable to install 2 filter driers and sight glasses in a single circuit application. One filter drier and sight glasses may be installed at A locations (see Fig. 10) or 2 filter driers and sight glasses may be installed at B locations (see Fig. 10 and 11).

Select the filter drier for maximum unit capacity and minimum pressure drop. Complete the refrigerant piping from the indoor unit to the outdoor unit before opening the liquid and suction lines at the outdoor unit.

### INSTALL LIQUID LINE SOLENOID VALVE

It is recommended that a solenoid valve be placed in the main liquid line (see Fig. 10 and 11) between the condensing unit and the evaporator coil. Locate the solenoid valve at the outlet end of the liquid line, near the evaporator coil connections, with flow direction arrow pointed at the evaporator coil. Refer to Table 12. (A liquid line solenoid valve is required when the liquid line length exceeds 75 ft [23 m].) This valve prevents refrigerant migration (which causes oil dilution) to the compressor during the off cycle, at low outdoor ambient temperatures. Wire the solenoid in parallel with the compressor contactor coil (see Fig. 10 and 11). This means of electrical control is referred to as solenoid drop control.

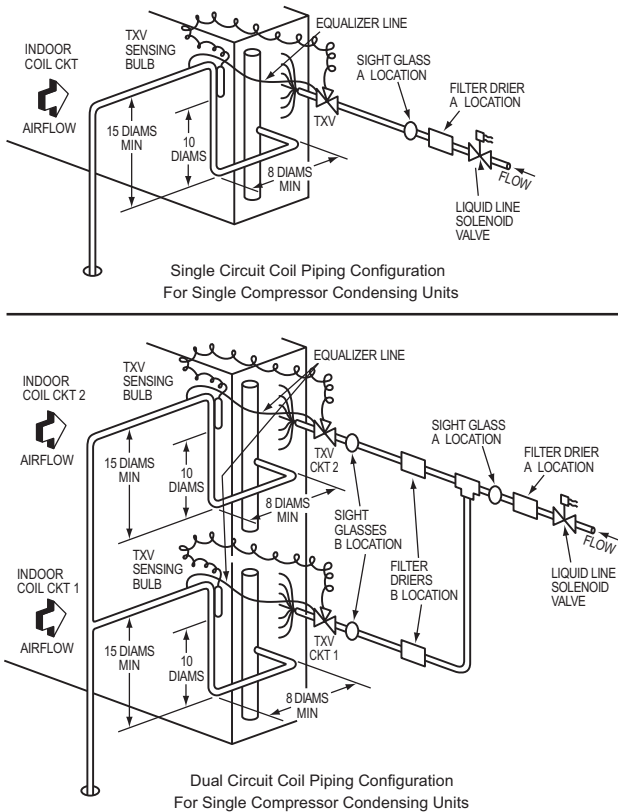

**Fig. 10 — Location of Sight Glass(es) and Filter Driers Typical 38AUZ Systems**

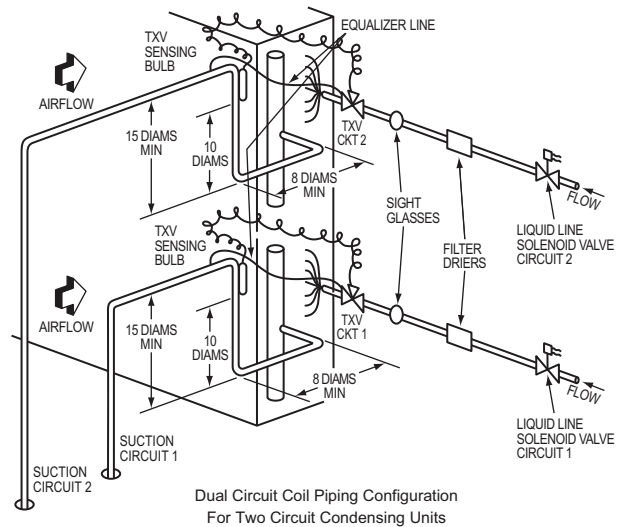

**Fig. 11 — Location of Sight Glasses and Filter Driers Typical 38AUD Systems**

### Solenoid Drop Control Wiring

Control the power to the liquid line solenoid through a Solenoid Valve Relay (SVR) in all units. Use part number HN61PC005 (field-supplied, installed). 38AUZ unit requires one SVR; 38AUD unit requires two relays.

A unit with two liquid line solenoid valves also requires a separate control power transformer for the liquid solenoid valve loads. Select TRAN3 transformer part number according to unit power supply.

MODEL	QTY LSV	RELAY SVR QTY - PART NUMBER	TRAN3 PRIMARY V: PART NUMBER
38AUZ	1	1 — HN61PC005	N/R
	2	2 — HN61PC005	208/230V: HT01BD202
38AUD	2	2 — HN61PC005	460V: HT01BD702
			575V: HT01BD902

### LEGEND

- LSV — Liquid Solenoid Valve
- SVR — Solenoid Valve Relay
- N/R — Not Required

Mount the SVR (and transformer TRAN3 when used) in unit control box. Connect per wiring schematic label on unit.

### Evaporator Capacity Control Liquid Line Solenoid Valve

Many older unit designs included automatic capacity controls that sensed changes in suction pressure and could increase or decrease compressor capacity automatically as the evaporator load changed. Control systems were used on these units that had the thermostat's second stage contacts control a capacity control liquid line solenoid valve to open or shutoff a portion of the evaporator surface without any direct connection to the compressor circuit.

This form of system capacity staging control is not possible with 38AU models. If this installation is a retrofit for a unit that included automatic pressure-operated unloading, check the existing thermostat and liquid solenoid valve. When found, convert the evaporator second stage solenoid control into a drop-solenoid control. Use the two SVR relays and transformer as required on 38AUD models (above); wire the SVRs and transformer per two solenoid valve systems.

## SELECTING AN ACCUMULATOR

Because all 38AU models use scroll compressors, an accumulator is not required. If an accumulator is to be added, check the accumulator manufacturer's literature carefully for indication of its suitability for use with R-410A; look for minimum working pressure of 200 psig (1380 kPa). Select the accumulator first on the basis of its cataloged minimum capacity (tons) to ensure oil return from the accumulator, then on tube size or holding capacity.

## MAKE PIPING CONNECTIONS

Piping connections at the 38AU unit are ball valves with stub tube extensions. Do not open the unit service valves until all interconnecting tube brazing has been completed. The stub tube connections include 1/4-in. SAE service fittings with Schrader valve cores (see Fig. 12). Before making any brazed connections to the unit service valves, remove both Schrader valve caps and cores and save for re-installation. Connect a source for nitrogen to one of these service fittings during tube brazing to prevent the formation of copper oxides inside the tubes at brazed joints.

When connecting the field tubing to the 38AU service valves, wrap the valves in wet rags to prevent overheating.

Pressure-test all joints from outdoor unit connections over to the evaporator coil, using nitrogen as pressure and with soap-and-bubbles.

When pressure-testing is completed, remove the nitrogen source at the outdoor unit service valves and re-install the two Schrader valve cores. Torque the cores to 2 to 3 in.-lb (23 to 34 N-cm).

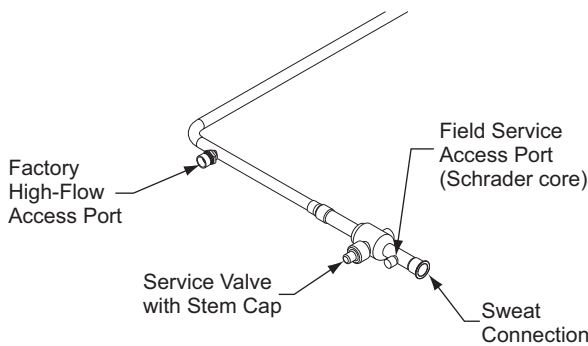

**Fig. 12 — Typical Piping Connection Assembly**

## EVACUATION/DEHYDRATION

Evacuate and dehydrate the connected refrigeration system(s) (excluding the 38AU unit) to 500 microns using a two-stage vacuum pump attached to the service ports outside the 38AU service valves, following description in GTAC II, Module 4, System Dehydration.

### **⚠ WARNING**

#### **UNIT OPERATION AND SAFETY HAZARD**

Failure to follow this warning could cause personal injury, death and/or equipment damage.

R-410A refrigerant systems operate at higher pressures than standard R-22 systems. Do not use R-22 service equipment or components on R-410A refrigerant equipment.

This unit is designed for use with Puron (R-410A) refrigerant. Do not use any other refrigerant in this system.

Puron (R-410A) refrigerant is provided in pink (rose) colored cylinders. These cylinders are available with and without dip tubes; cylinders with dip tubes will have a label indicating this feature. For a cylinder with a dip tube, place the cylinder in the upright position (access valve at the top) when removing liquid refrigerant for charging. For a cylinder without a dip tube, invert the cylinder (access valve on the bottom) when removing liquid refrigerant.

Because Puron (R-410A) refrigerant is a blend, it is strongly recommended that refrigerant always be removed from the cylinder as a liquid. Admit liquid refrigerant into the system in the discharge line. If adding refrigerant into the suction line, use a commercial metering/expansion device at the gauge manifold; remove liquid from the cylinder, pass it through the metering device at the gauge set and then pass it into the suction line as a vapor. Do not remove Puron (R-410A) refrigerant from the cylinder as a vapor.

## PRELIMINARY CHARGE

Before starting the unit, charge R-410A liquid refrigerant into the high side of each 38AU circuit through the liquid service valve(s). The amount of refrigerant added must be at least 80% of the operating charge listed in Tables 4 or 5 for LINEAR line length LESS the factory charge quantity (if factory shipping charge has not been removed). See example below.

NOTE: See "Adjust Refrigerant Charge" on page 21 for details on refrigerant charge adjustment. Be sure that all condenser fans are operating while charging the unit.

Allow high and low side pressures to equalize. If pressures do not equalize readily, charge R-410A vapor (using special service manifold with expansion device) into the suction line service port for the low side of system to assure charge in the evaporator. Refer to GTAC II, Module 5, Charging, Recover, Recycling, and Reclamation for liquid charging procedures.

Example:

38AUZ\*25

60-ft (18.3 m) linear line length

Equivalent line length 90-ft (27.4 m)

Liquid Lift: 20-ft (6.1 m)

Select line sizes from Table 8 (38AUD):

Liquid 1/2 in.

Suction 1-1/8 in.

Charge

Circuit 1: 23.1 lb (at 75-ft linear length)

Circuit 2: 22.0 lb

80% of Operating Charge:

Circuit 1:  $0.80 \times 23.0 = 18.4$  lb

Circuit 2:  $0.80 \times 22.0 = 17.6$  lb

Factory Shipping Charge: 15 lb

Field-Charge

Circuit 1:  $18.4 - 15.0 = 3.4$  lb

Circuit 2:  $17.6 - 15.0 = 2.6$  lb

For linear line lengths longer than 125 ft (38 m), contact your local Carrier representative for system charge value.

## Step 7 — Install Accessories

Accessories requiring modifications to unit wiring should be completed now. These accessories may include Winter Start controls and Low Ambient controls. Refer to the instructions shipped with the accessory.



## Step 8 — Complete Electrical Connections

### ⚠ WARNING

#### ELECTRIC SHOCK HAZARD

Failure to follow this warning could result in personal injury or death.

Unit cabinet must have an uninterrupted, unbroken electrical ground to minimize the possibility of personal injury if an electrical fault should occur. This ground may consist of electrical wire connected to unit ground lug in control compartment, or conduit approved for electrical ground when installed in accordance with NEC; ANSI/NFPA 70, latest edition (in Canada, Canadian Electrical Code CSA [Canadian Standards Association] C22.1), and local electrical codes.

**NOTE:** Check all factory and field electrical connections for tightness. Field-supplied wiring shall conform with the limitations of 63°F (33°C) rise.

#### FIELD POWER SUPPLY

If equipped with optional Powered Convenience Outlet: The power source leads to the convenience outlet's transformer primary are not factory connected. Installer must connect these leads according to required operation of the convenience outlet. If an always-energized convenience outlet operation is desired, connect the source leads to the line side of the unit-mounted disconnect. (Check with local codes to ensure this method is acceptable in your area.) If a de-energize via unit disconnect switch operation of the convenience outlet is desired, connect the source leads to the load side of the unit disconnect. On a unit without a unit-mounted disconnect, connect the source leads to compressor contactor C and indoor fan contactor IFC pressure lugs with unit field power leads.

Field power wires are connected to the unit at line-side pressure lugs on compressor contactor C and TB1 (see wiring diagram label for control box component arrangement) or at factory-installed option non-fused disconnect switch. Max wire size is #4 AWG (copper only).

**NOTE: TEST LEADS** — Unit may be equipped with short leads (pigtailed) on the field line connection points on contactor C or optional disconnect switch. These leads are for factory run-test purposes only; remove and discard before connecting field power wires to unit connection points. Make field power connections directly to line connection pressure lugs only.

### ⚠ WARNING

#### FIRE HAZARD

Failure to follow this warning could result in personal injury, death, or property damage.

Do not connect aluminum wire between disconnect switch and unit. Use only copper wire. (See Fig. 13.)

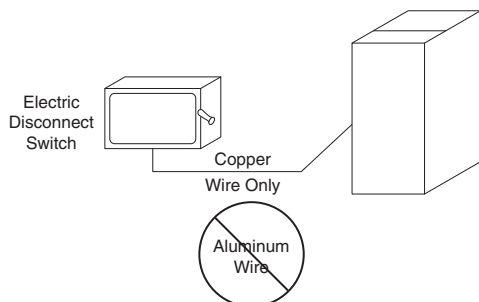

**Fig. 13 — Disconnect Switch and Unit**

## UNITS WITH FACTORY-INSTALLED NON-FUSED DISCONNECT

The factory-installed option disconnect switch is located in a weatherproof enclosure located under the main control box. The manual switch handle is accessible through an opening in the access panel.

## UNITS WITHOUT FACTORY-INSTALLED NON-FUSED DISCONNECT

When installing units, provide a disconnect switch per NEC (National Electrical Code) of adequate size. Disconnect sizing data is provided on the unit informative plate. Locate on unit cabinet or within sight of the unit per national or local codes. Do not cover unit informative plate if mounting the disconnect on the unit cabinet.

#### ALL UNITS

All field wiring must comply with NEC and all local codes. Size wire based on MCA (Minimum Circuit Amps) on the unit informative plate. See Fig. 14 for power wiring connections to the unit contactor and terminal block and equipment ground.

#### Units Without Disconnect Option

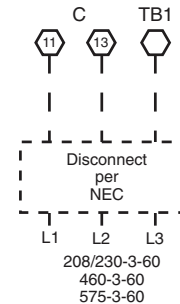

#### Units With Disconnect Option

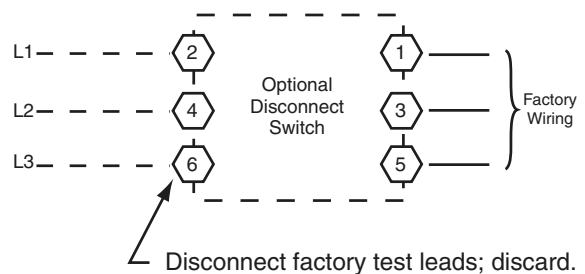

**Fig. 14 — Power Wiring Connections**

Provide a ground-fault and short-circuit over-current protection device (fuse or breaker) per NEC Article 440 (or local codes). Refer to unit informative data plate for MOCP (Maximum Over-current Protection) device size.

All units except 208/230-v units are factory wired for the voltage shown on the nameplate. If the 208/230-v unit is to be connected to a 208-v power supply, the control transformer must be rewired by moving the black wire with the 1/4-in. female spade connector from the 230-v connection and moving it to the 208-v 1/4-in. male terminal on the primary side of the transformer. Refer to unit label diagram for line-side information.

Affix the crankcase heater warning sticker to the unit disconnect switch.



**⚠ WARNING**

**ELECTRICAL OPERATION HAZARD**

Failure to follow this warning could result in personal injury or death.

Units with convenience outlet circuits may use multiple disconnects. Check convenience outlet for power status before opening unit for service. Locate its disconnect switch, if appropriate, and open it. Lock-out and tag-out this switch, if necessary.

Two types of convenience outlets are offered on 38AU models: Non-powered and unit-powered. Both types provide a 125-volt GFCI (ground-fault circuit-interrupter) duplex receptacle rated at 15-A behind a hinged waterproof access cover, located on the end panel of the unit. See Fig. 15.

**Non-Powered Type**

This type requires the field installation of a general-purpose 125-volt 15-A circuit powered from a source elsewhere in the building. Observe national and local codes when selecting wire size, fuse or breaker requirements and disconnect switch size and location. Route 125-v power supply conductors into the bottom of the utility box containing the duplex receptacle. Maximum continuous current for this type of convenience outlet (non-unit powered) must not exceed 8 Amps.

**Unit-Powered Type**

A unit-mounted transformer is factory-installed to step down the main power supply voltage to the unit to 115-v at the duplex receptacle. This option also includes a manual switch with fuse, located in a utility box and mounted on a bracket behind the convenience outlet; access is through the unit's control box access panel. See Fig. 15.

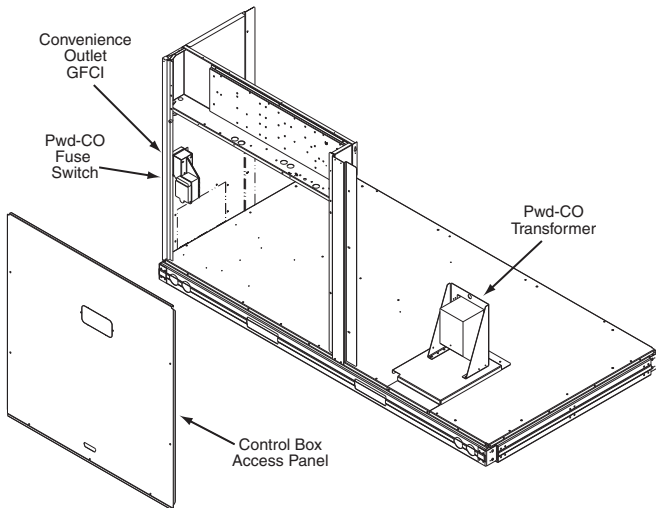

**Fig. 15 — Convenience Outlet Location**

The primary leads to the convenience outlet transformer are not factory-connected. Selection of primary power source is a customer-option. If local codes permit, the transformer primary leads can be connected at the line-side terminals on the unit-mounted non-fused disconnect switch; this will provide service power to the unit when the unit disconnect switch is open. Other connection methods will result in the convenience outlet circuit being de-energized when the unit disconnect switch is open. See Fig. 16.

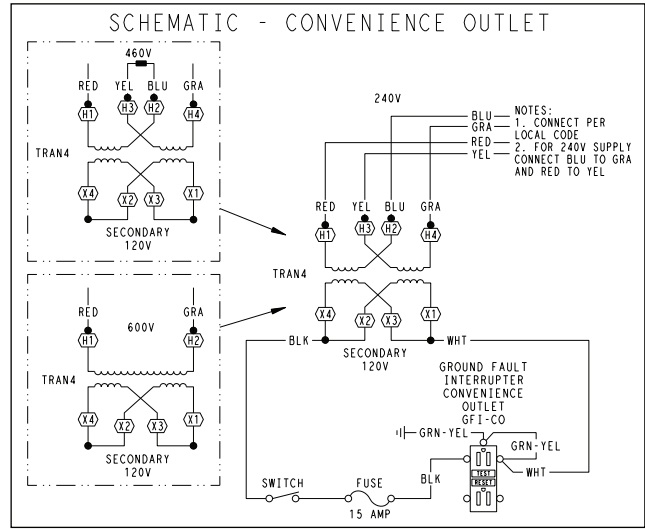

UNIT VOLTAGE	CONNECT AS	PRIMARY CONNECTIONS	TRANSFORMER TERMINALS
208, 230	240	L1: RED + YEL L2: BLU + GRA	H1 + H3 H2 + H4
460	480	L1: RED L2: Splice BLU + YEL L3: GRA	H1 H2 + H3 H4
575	600	L1: RED L2: GRA	H1 H2

**Fig. 16 — Powered Convenience Outlet Wiring**

The unit-powered convenience outlet has a 1000 VA rated transformer. Maximum continuous current must not exceed 8 Amps.

Test the GFCI receptacle by pressing the TEST button on the face of the receptacle to trip and open the receptacle. Check for proper grounding wires and power line phasing if the GFCI receptacle does not trip as required. Press the RESET button to clear the tripped condition.

Fuse on power type: The factory fuse is a Bussman<sup>1</sup> "Fusetron" T-15, non-renewable screw-in (Edison base) type plug fuse.

**⚠ WARNING**

**ELECTRICAL OPERATION HAZARD**

Failure to follow this warning could result in personal injury or death.

Using unit-mounted convenience outlets: Units with unit-mounted convenience outlet circuits will often require that two disconnects be opened to de-energize all power to the unit. Treat all units as electrically energized until the convenience outlet power is also checked and de-energization is confirmed. Observe National Electrical Code Article 210, Branch Circuits, for use of convenience outlets.

**Installing Weatherproof Cover**

A weatherproof while in use cover for the factory installed convenience outlets is now required by UL standards. This cover cannot be factory mounted due its depth; it must be installed at unit installation. For shipment, the convenience outlet is covered with a blank cover plate.

The weatherproof cover kit is shipped in the unit's control box. The kit includes the hinged cover, a backing plate and gasket.

**DISCONNECT ALL POWER TO UNIT AND CONVENIENCE OUTLET.**

1. Bussmann and Fusetron are trademarks of Eaton.

Remove the blank cover plate at the convenience outlet; discard the blank cover.

Loosen the two screws at the GFCI duplex outlet, until approximately 1/2-in. (13 mm) under screw heads are exposed. Press the gasket over the screw heads. Slip the backing plate over the screw heads at the keyhole slots and align with the gasket; tighten the two screws until snug (do not overtighten).

Mount the weatherproof cover to the backing plate as shown in Fig. 17. Remove two slot fillers in the bottom of the cover to permit service tool cords to exit the cover. Check for full closing and latching.

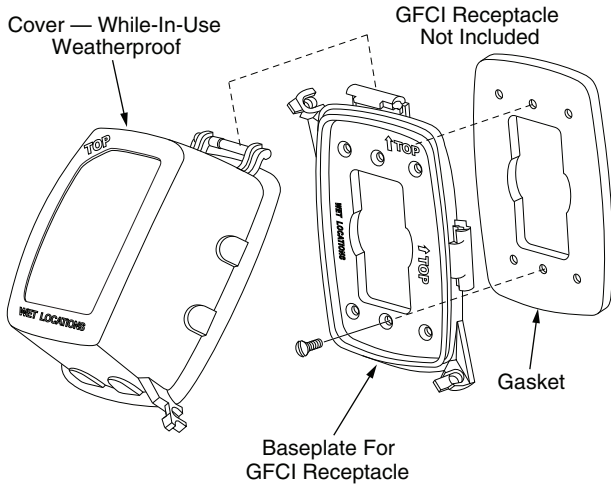

**Fig. 17 — Weatherproof Cover Installation**

**ALL UNITS**

Voltage to compressor terminals during operation must be within voltage range indicated on unit nameplate. See Tables 13 and 14 (on page 19). On 3-phase units, voltages between phases must be balanced within 2% and the current within 10%. Use the formula shown in the legend for Table 13, Note 5 (see page 20) to determine the percent of voltage imbalance. Operation on improper line voltage or excessive phase imbalance constitutes abuse and may cause damage to electrical components. Such operation would invalidate any applicable Carrier warranty.

**FIELD CONTROL WIRING**

The 38AU unit control voltage is 24 v. See Appendix B Wiring Diagrams (on pages 39-54) for typical field control connections and the unit's label diagram for field-supplied wiring details. Route control wires to the 38AU unit through the opening in unit's end panel to the connections terminal board in the unit's control box.

Remainder of the system controls connection will vary according to the specific construction details of the indoor section (air handler or packaged fan coil). Figures 18 (38AUZ) and 19 (38AUD) depict typical connections to a Carrier 40RU fan coil unit. Plan for field connections carefully and install control wiring correctly per the project plan. Additional components and supplemental transformer accessory may be required.

The 38AU unit requires an external temperature control device. This device can be a thermostat (field-supplied).

**THERMOSTAT**

Install a Carrier-approved accessory thermostat according to installation instructions included with the accessory. For typical thermostat connections see Figures 18 (38AUZ) and 19 (38AUD). Locate the thermostat accessory on a solid wall in the conditioned space to sense average temperature in accordance with the thermostat installation instructions.

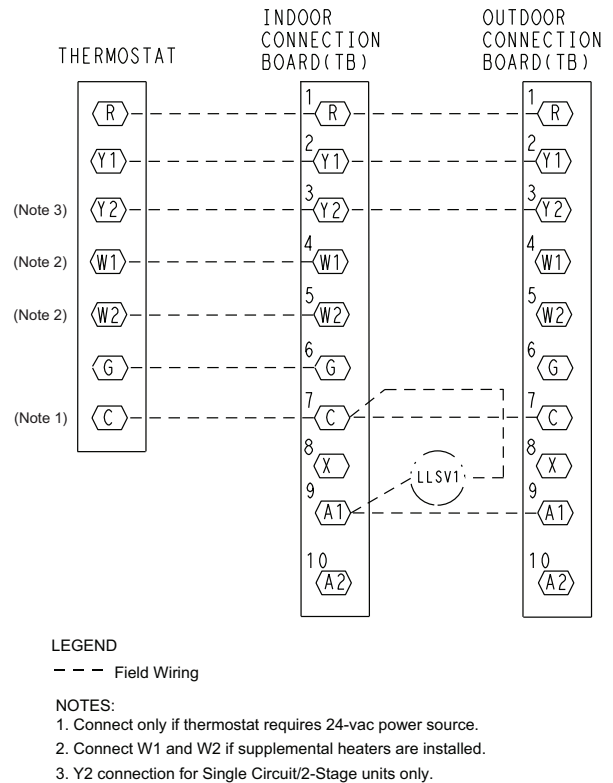

**Fig. 18 — Typical Remote Thermostat Connections - 38AUZ**

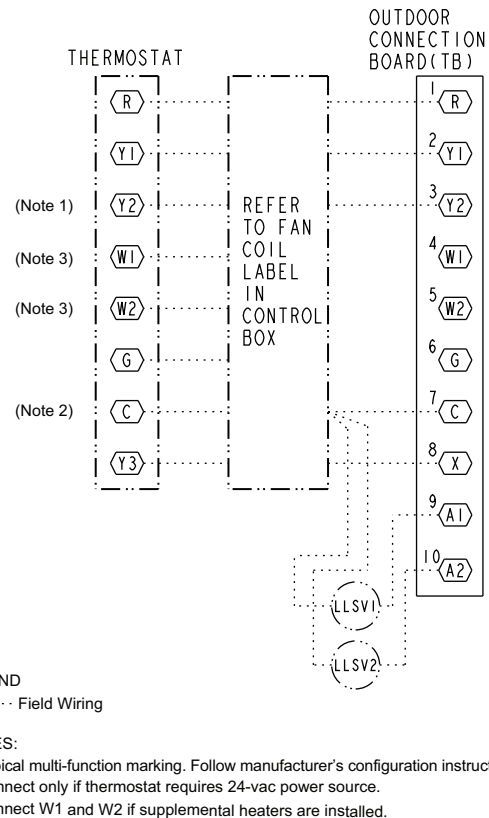

**Fig. 19 — Typical Remote Thermostat Connections - 38AUD**

The 38AUZ is a single-circuit, two-stage cooling unit. Select a two-stage cooling thermostat, with or without supplemental heating as needed.

The 38AUD is a dual-circuit, three-stage cooling unit. Select a three-stage cooling thermostat, with or without supplemental heating as needed.

Select a thermostat cable or equivalent single leads of different colors with minimum of five leads for 38AUZ or six leads for 38AUD unit. Check the thermostat installation instructions for additional features which might require additional conductors in the cable.

For wire runs up to 50 ft (15 m), use no. 18 AWG (American Wire Gage) insulated wire (35°C minimum). For 50 to 75 ft. (15 to 23 m), use no. 16 AWG insulated wire (35°C minimum). For over 75 ft (23 m), use no. 14 AWG insulated wire (35°C minimum). All wire sizes larger than no. 18 AWG cannot be directly connected to the thermostat and will require a junction box and splice at the thermostat.

**CONTROL CIRCUIT WIRING**

Control voltage is 24 v. See Fig. 14 and the unit’s label diagram for field-supplied wiring details. Route control wires through the opening in unit’s end panel to the connection in the unit’s control box.

**CONTROL TRANSFORMER WIRING**

On multi voltage units, check the transformer primary wiring connections. See Fig. 20 or refer to the unit’s label diagram.

If the unit will be operating at 208-3-60 power, remove the black wire (BLK) from the transformer primary connection labeled “230” and move it to the connection labeled “208”. See Fig. 20.

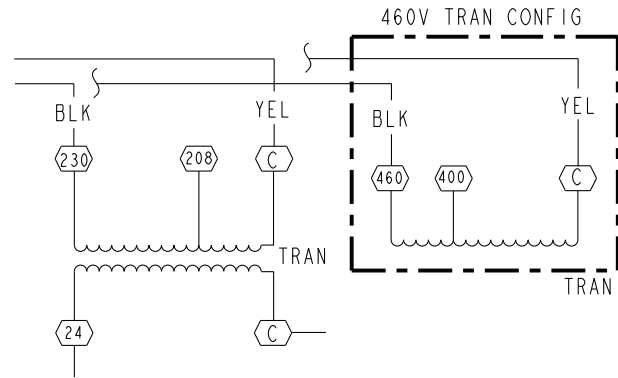

**Fig. 20 — Control Transformer Wiring**

**EXTERNAL DEVICES**

The 38AU control transformers provide 24-v NEC Class 2 power sources to energize external control devices. These devices will include the indoor fan motor contactor (or control relay). These devices may also include liquid line solenoid valve (two on 38AUD model), economizer control relay, supplemental electric heater contactors or control relays and other devices selected by system designer.

Control transformer TRAN1 provides control power through terminal R to C on the field connection terminal strip TB for supply fan motor interlock. This source may also be used to energize economizer control relay and electric heater contactors or relays. Maximum available power is 20 va. Check concurrent loadings by external control devices. If the maximum concurrent loading exceeds 20 va, purchase and install the accessory Transformer-Relay package (available for 208/230 and 460-v units).

**38AUD Only**

Control transformer TRAN3 provides control power through terminals A1 (9) and A2 (10) to C for liquid line solenoids. Maximum available power is 75 va. These outputs are switched ON/OFF by the Solenoid Valve Relays.

**Table 13 — 38AUZ Unit Wire/Fuse or HACR Breaker Sizing Data<sup>a</sup>**

UNIT SIZE 38AUZ	NUMBER OF STAGES	NOMINAL POWER SUPPLY V-Ph-Hz	VOLTAGE RANGE Min Max		COMPRESSOR				NO C.O. OR PWRD C.O.					
					No. 1		No. 2		OFM		Power Supply		Disconnect Size	
					RLA	LRA	RLA	LRA	Qty	FLA (ea)	MCA	Fuse or HACR Breaker	FLA	LRA
A16	2	208/230	187	253	25.0	164	25.0	164	3	1.5	60.8/60.8	80/80	63/63	337/337
		460	414	506	12.2	100	12.2	100	3	0.8	29.9	40	31	206
		575	518	633	9.0	78	9.0	78	3	0.7	22.4	30	23	162
A25	2	208/230	187	253	30.1	225	30.1	225	4	1.5	73.7/73.7	100/100	76/76	462/462
		460	414	506	16.7	114	16.7	114	4	0.8	40.8	50	42	236
		575	518	633	12.2	80	12.2	80	4	0.7	30.3	40	31	168

UNIT SIZE 38AUZ	NUMBER OF STAGES	NOMINAL POWER SUPPLY V-Ph-Hz	VOLTAGE RANGE Min Max		COMPRESSOR				WITH PWRD C.O.					
					No. 1		No. 2		OFM		Power Supply		Disconnect Size	
					RLA	LRA	RLA	LRA	Qty	FLA (ea)	MCA	Fuse or HACR Breaker	FLA	LRA
A16	2	208/230-3-60	187	253	25.0	164	25.0	164	3	1.5	60.8/60.8	80/80	63/63	337/337
		460-3-60	414	506	12.2	100	12.2	100	3	0.8	29.9	40	31	206
		575-3-60	518	633	9.0	78	9.0	78	3	0.7	22.4	30	23	162
A25	2	208/230-3-60	187	253	30.1	225	30.1	225	4	1.5	73.7/73.7	100/100	76/76	462/462
		460-3-60	414	506	16.7	114	16.7	114	4	0.8	40.8	50	42	236
		575-3-60	518	633	12.2	80	12.2	80	4	0.7	30.3	40	31	168

NOTE(S):

a. See Legend and Notes for Tables 13 and 14 on page 20.

**Table 14 — 38AUD Unit Wire/Fuse or HACR Breaker Sizing Data<sup>a</sup>**

UNIT SIZE 38AUD	NUMBER OF STAGES	NOMINAL POWER SUPPLY V-Ph-Hz	VOLTAGE RANGE Min Max		COMPRESSOR				NO C.O. OR PWRD C.O.					
					No. 1		No. 2		OFM		Power Supply		Disconnect Size	
					RLA	LRA	RLA	LRA	Qty	FLA (ea)	MCA	Fuse or HACR Breaker	FLA	LRA
T16	3	208/230-3-60	187	253	26.8	164	25.0	164	3	1.5	63/63	80/80	65/65	337/337
		460-3-60	414	506	12.0	94	12.2	100	3	0.8	29.7	40	31	200
		575-3-60	518	633	9.0	65	9.9	78	3	0.7	23.5	30	24	149
T25	3	208/230-3-60	187	253	32.5	240	28.2	240	4	1.5	74.8/74.8	100/100	77/77	492/492
		460-3-60	414	506	14.8	130	14.7	130	4	0.8	36.4	50	38	268
		575-3-60	518	633	11.1	94	11.3	94	4	0.7	28	35	29	196
T28	3	208/230-3-60	187	253	35.3	240	48.4	245	4	1.5	101.8/101.8	150/150	103/103	497/497
		460-3-60	414	506	17.0	140	19.0	125	4	0.8	44	60	45	273
		575-3-60	518	633	13.0	108	16.0	100	4	0.7	35.8	50	37	216

UNIT SIZE 38AUD	NUMBER OF STAGES	NOMINAL POWER SUPPLY V-Ph-Hz	VOLTAGE RANGE Min Max		COMPRESSOR				WITH PWRD C.O.					
					No. 1		No. 2		OFM		Power Supply		Disconnect Size	
					RLA	LRA	RLA	LRA	Qty	FLA (ea)	MCA	Fuse or HACR Breaker	FLA	LRA
T16	3	208/230-3-60	187	253	26.8	164	25.0	164	3	1.5	67.8/67.8	90/90	70/70	342/342
		460-3-60	414	506	12.0	94	12.2	100	3	0.8	31.9	40	33	202
		575-3-60	518	633	9.0	65	9.9	78	3	0.7	25.2	30	26	151
T25	3	208/230-3-60	187	253	32.5	240	28.2	240	4	1.5	79.6/79.6	100/100	82/82	497/497
		460-3-60	414	506	14.8	130	14.7	130	4	0.8	38.6	50	40	270
		575-3-60	518	633	11.1	94	11.3	94	4	0.7	29.7	40	31	198
T28	3	208/230-3-60	187	253	35.3	240	48.4	245	4	1.5	106.6/106.6	150/150	109/109	502/502
		460-3-60	414	506	17.0	140	19.0	125	4	0.8	46.2	60	48	275
		575-3-60	187	253	26.8	164	25.0	164	3	1.5	67.8/67.8	90/90	70/70	342/342

NOTE(S):

a. See Legend and Notes for Tables 13 and 14 on page 20.

## Legend and Notes for Tables 13-14

### LEGEND

- FLA** — Full Load Amps  
**LRA** — Locked Rotor Amps  
**MOCP** — Maximum Over Current Protection  
**NEC** — National Electrical Code  
**RLA** — Rated Load Amps

### NOTES

- In compliance with NEC requirements for multimotor and combination load equipment (refer to NEC Articles 430 and 440), the over-current protective device for the unit shall be fuse or HACR breaker. Canadian units may be fuse or circuit breaker.
- The MCA and Fuse values are calculated in accordance with the NEC Article 440.
- Motor RLA and LRA values are established in accordance with Underwriters Laboratories (UL) Standard 1995.
- The 575-v units are UL, Canada-listed only.
- Unbalanced 3-Phase Supply Voltage. Never operate a motor where a phase imbalance in supply voltage is greater than 2%. Use the following formula to determine the percentage of voltage imbalance.

$$\% \text{ Voltage Imbalance} = 100 \times \frac{\text{max voltage deviation from average voltage}}{\text{average voltage}}$$

Example: Supply voltage is 230-3-60

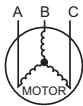

AB = 224 v  
 BC = 231 v  
 AC = 226 v

$$\text{Average Voltage} = \frac{(224 + 231 + 226)}{3} = \frac{681}{3} = 227$$

Determine maximum deviation from average voltage.

$$(AB) 227-224 = 3 \text{ v}$$

$$(BC) 231-227 = 4 \text{ v}$$

$$(AC) 227-226 = 1 \text{ v}$$

Maximum deviation is 4 v.

Determine percent of voltage imbalance.

$$\% \text{ Voltage Imbalance} = 100 \times \frac{4}{227} = 1.78\%$$

This amount of phase imbalance is satisfactory as it is below the maximum allowable 2%.

**IMPORTANT:** If the supply voltage phase imbalance is more than 2%, contact your local electric utility company immediately.

## Step 9 — Wind Baffles for Low Ambient Control

Models 38AUZB and 38AUDU include the factory installed 32LT Motormaster® Low Ambient Control.

Units with 32LT Motormaster control require the addition of wind baffles to ensure full range low ambient operation. Material data and dimensions for wind baffles are included in Appendix C, Low Ambient Control, starting on page 55. Fabricate the wind baffles and mount per instructions.

## PRE-START-UP

**IMPORTANT:** Before beginning Pre-Start-Up or Start-Up, review Start-Up Checklist at the back of this book. The Checklist assures proper start-up of a unit and provides a record of unit condition, application requirements, system information, and operation at initial start-up.

### ⚠ CAUTION

#### UNIT DAMAGE HAZARD

Failure to follow this caution may result in equipment damage. Do not attempt to start the condensing unit, even momentarily, until the following steps have been completed. Compressor damage may result.

## System Check

- The electrical power source must agree with the unit's name-plate rating.
- Check all air handler(s) and other equipment auxiliary components. Consult the manufacturer's instructions regarding any other equipment connected to the condensing unit. If the unit has field-installed accessories, be sure all are properly installed and correctly wired. If used, the airflow switch must be properly installed.
- Check tightness of all electrical connections.
- Be sure liquid line and low side of the system are properly leak checked and dehydrated.
- Be sure the unit is properly charged. See "Preliminary Charge", below.
- Open the liquid line and suction line service valves.
- The crankcase heater must be firmly attached to the compressor crankcase. Be sure the crankcase is warm (heater must be on for 24 hours before starting compressor).

## Turn On Crankcase Heater

Turn on the crankcase heater for 24 hours before starting the unit to be sure all the refrigerant is out of the oil. To energize the crankcase heater, proceed as follows:

- Set the space thermostat set point above the space temperature so there is no demand for cooling.
- Close the field disconnect.

## Preliminary Charge

Before starting the unit, charge liquid refrigerant into the high side of the system through the liquid service valve. The amount of refrigerant added must be at least 80% of the operating charge listed in the Physical Data table (Tables 4 and 5). Allow high and low side pressures to equalize before starting compressor. If pressure do not equalize readily, charge vapor on low side of system to assure charge in the evaporator. Refer to GTAC II, Module 5, Charging, Recover, Recycling, and Reclamation for liquid charging procedures.

### ⚠ CAUTION

#### UNIT DAMAGE HAZARD

Failure to follow this caution may result in equipment damage. Prior to starting compressor, a preliminary charge of refrigerant must be added to avoid possible compressor damage.



## START-UP

The compressor crankcase heater must be on for 24 hours before start-up. After the heater has been on for 24 hours, the unit can be started. If no time elapsed since the preliminary charge step was completed, it is unnecessary to wait the 24-hour period.

### Preliminary Checks

1. Check that electric power supply agrees with unit nameplate data.
2. Verify that the compressor crankcase heater is securely in place.
3. Check that the compressor crankcase heater has been on at least 24 hours.
4. Recheck for leaks using the procedure outlined in the Pre-Start-Up section, Leak Test and Dehydration. If any leaks are detected, repair as required. Evacuate and dehydrate as described in the Leak Test and Dehydration section.
5. Ensure that the preliminary charge has been added as described in the Pre-Start-Up section, Preliminary Charge.
6. All internal wiring connections must be tight, and all barriers and covers must be in place.

NOTE: The 38AU units are factory charged with the required amount of oil. If recharging is required, use Emkarate RL 32-3MAF for the 38AU units.

### COMPRESSOR ROTATION

On 3-phase units with scroll compressors, it is important to be certain that the compressor is rotating in the proper direction. 38AU units are equipped with a Comfort Alert Diagnostic Module (CADM). Alert Code 7 indicates reverse power phasing.

To correct phase order:

1. Turn off power to the unit, tag disconnect.
2. Reverse any two of the unit power leads.
3. Reapply power to the compressor, verify correct pressures.

To verify the compressor is rotating in the proper direction:

1. Connect service gages to the suction and liquid pressure fittings.
2. Energize the compressor.
3. The suction pressure should drop and the liquid pressure should rise, as is normal on any start-up.

### COMPRESSOR OVERLOAD

This overload interrupts power to the compressor when either the current or internal motor winding temperature becomes excessive, and automatically resets when the internal temperature drops to a safe level. This overload may require up to 60 minutes (or longer) to reset. If the internal overload is suspected of being open, disconnect the electrical power to the unit and check the circuit through the overload with an ohmmeter or continuity tester.

### ADVANCED SCROLL TEMPERATURE PROTECTION (ASTP)

A label located above the terminal box identifies Copeland<sup>1</sup> Scroll compressor models that contain this technology. See Fig. 21. Advanced Scroll Temperature Protection (ASTP) is a form of internal discharge temperature protection, that unloads the scroll compressor when the internal temperature reaches approximately 149°C (300°F). At this temperature, an internal bi-metal disk valve opens and causes the scroll elements to separate, which stops compression. Suction and discharge pressures balance while the motor continues to run. The longer

the compressor runs unloaded, the longer it must cool before the bi-metal disk resets. See Fig. 22.

To manually reset ASTP, the compressor should be stopped and allowed to cool. If the compressor is not stopped, the motor will run until the motor protector trips, which occurs up to 90 minutes later. Advanced Scroll Temperature Protection will reset automatically before the motor protector resets, which may take up to 2 hours.



Fig. 21 — Advanced Scroll Temperature Protection Label

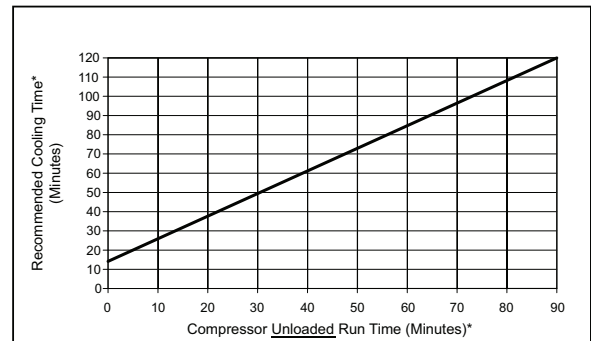

#### NOTES:

1. Various factors, including high humidity, high ambient temperature, and the presence of a sound blanket will increase cool-down times.

\*Times are approximate.

Fig. 22 — Recommended Minimum Cool-Down Time After Compressor is Stopped

### Start Unit

Set the space thermostat to a set point above space temperature so that there is no demand for cooling. Close the 38AU disconnect switch. Only the crankcase heater will be energized.

Reset the space thermostat below ambient so that a call for cooling is ensured.

**⚠ CAUTION**

**UNIT DAMAGE HAZARD**

Failure to follow this caution may result in equipment damage.

Never charge liquid into the low-pressure side of system. Do not overcharge. During charging or removal of refrigerant, be sure indoor-fan system is operating. Ensure both outdoor fan motors are running; bypass any Motormaster function.

### ADJUST REFRIGERANT CHARGE

Refer to Cooling Charging Charts, Fig. 24-28. For applications with line lengths greater than 125 ft (38 m), contact Carrier representative. Make sure that all condenser fans are operating before adjusting charge to the charging charts. Vary refrigerant until the conditions of the chart are met. Note that the charging charts are different from the type normally used. The charts are based on

1. Copeland is a trademark of Emerson Electric Co.

charging the units to the correct subcooling for the various operating conditions. Accurate pressure gage and temperature sensing device are required. Connect the pressure gage to the service port on the liquid line service valve. Mount the temperature sensing device on the liquid line close to the liquid line service valve, and insulate it so that outdoor ambient temperature does not affect the reading. Indoor airflow must be within the unit's normal operating range. Operate the unit for a minimum of 15 minutes. Ensure that pressure and temperature readings have stabilized. Plot the liquid pressure and temperature on chart and add or reduce the charge to meet the curve. see Table 15. Adjust the charge to conform with the charging chart, using the liquid pressure and temperature to read the chart.

**Table 15 — Using Plotted Operating Point**

IF PLOTTED OPERATING CONDITION IS	ADJUST CHARGE BY
BELOW the curve	REDUCE charge
ABOVE the curve	ADD charge

**38AUZ\*25 CHECK COMPRESSOR OIL LEVEL**

After adjusting the refrigerant charge, allow the unit to run fully loaded for 20 minutes. Stop the compressors and check the oil level. Oil level should be 1/3 to 1/2 up on the sight glass (see Fig. 23).

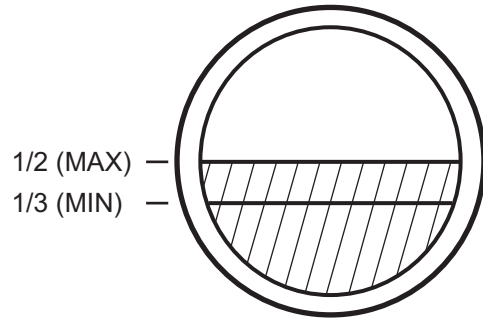
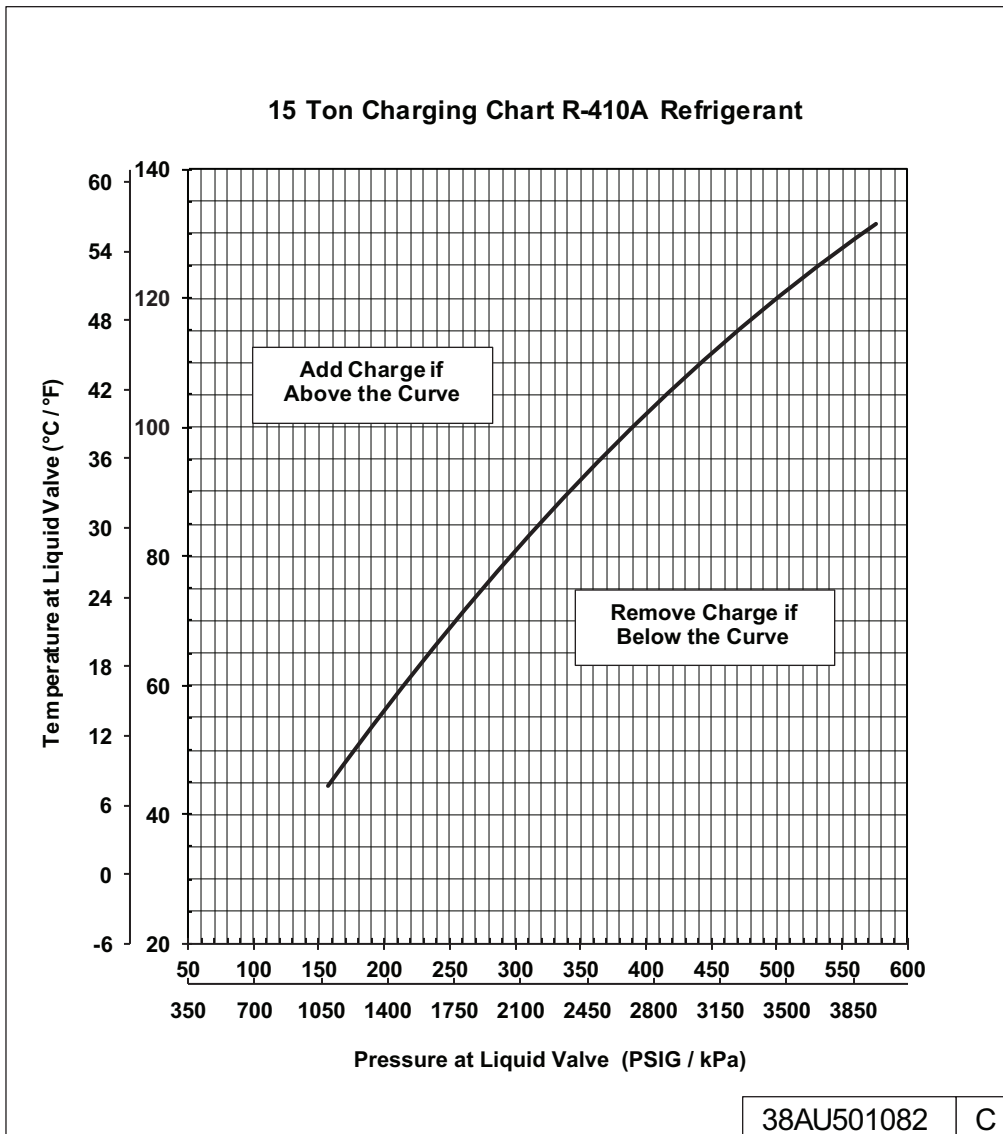

**Fig. 23 — Recommended Oil Level — 38AUZ\*25**

Add oil only if necessary to bring the oil into view in the sight glass. If oil is added, run the circuit for an additional 10 minutes, then stop and check oil level. If the level remains low, check the piping system for proper design for oil return; also, check the system for leaks. If checking the oil level with unit running in part load, let unit run one hour, then run at full load for 10 minutes. If oil does not return to acceptable sight glass levels, check for correct suction piping and line sizing.

**FINAL CHECKS**

Ensure that all safety controls are operating, control panel covers are on, and the service panels are in place.



**Fig. 24 — 38AUZ\*16 Charging Chart**



20 Ton Charging Chart R-410A Refrigerant

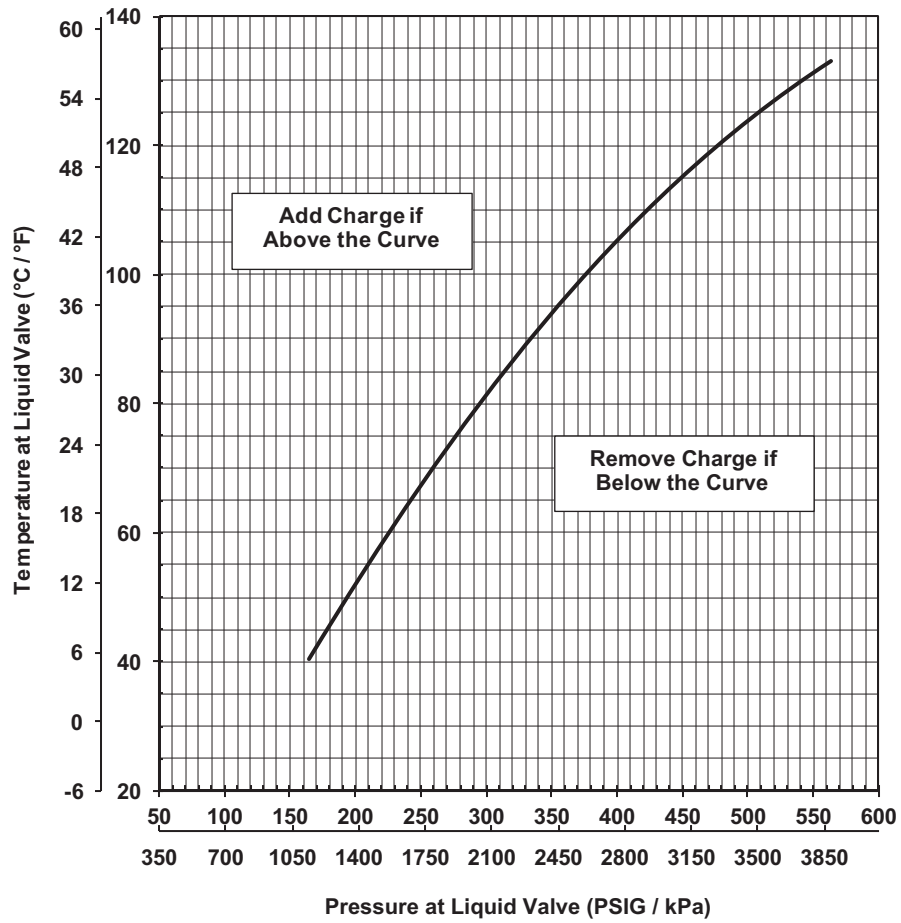

38AU500733

D

Fig. 25 — 38AUZ\*25 Charging Chart

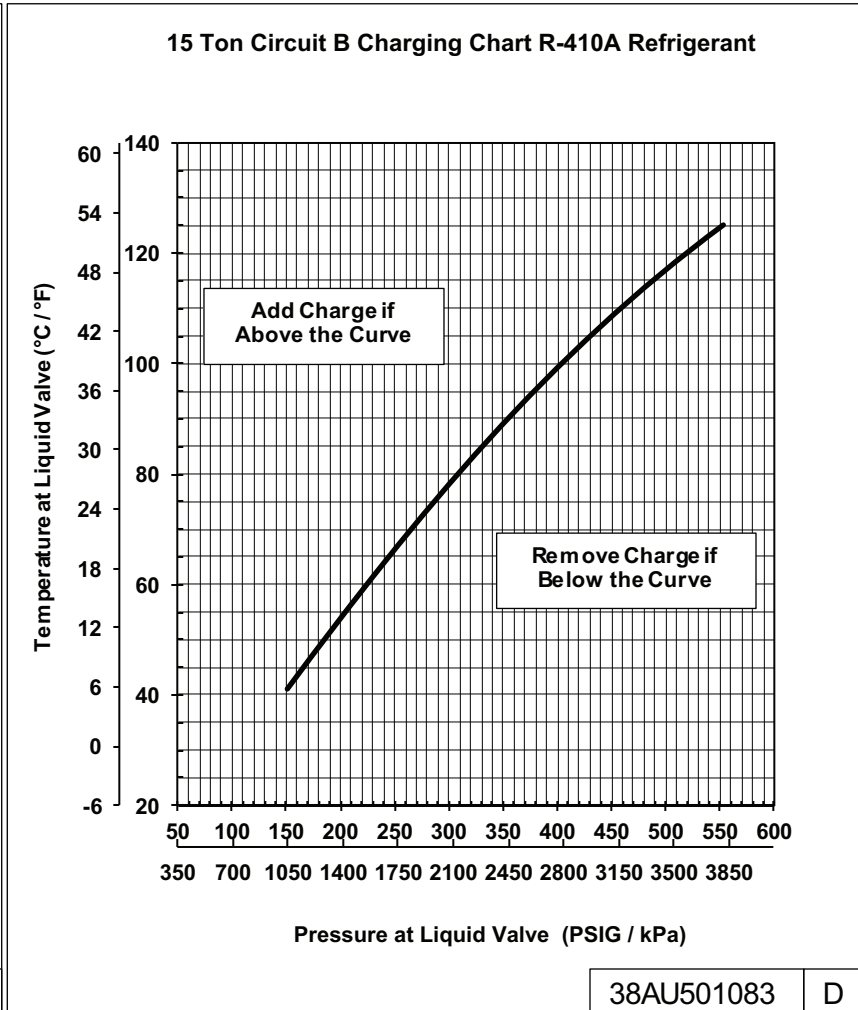
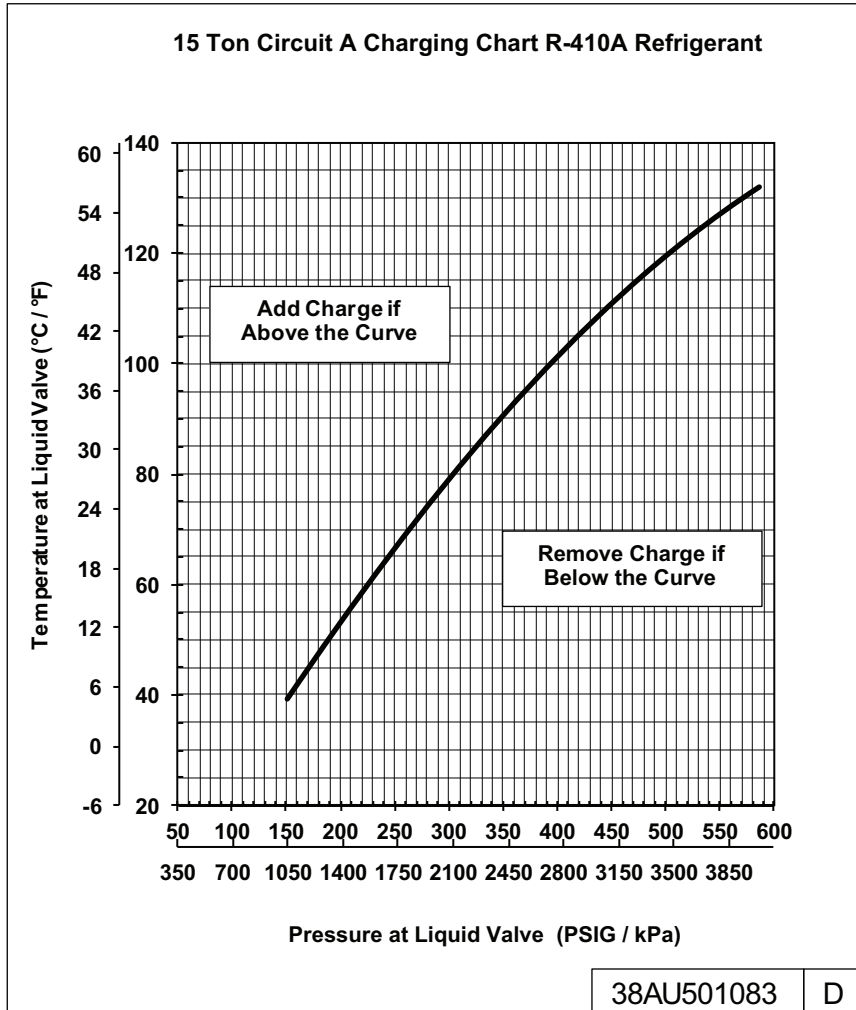
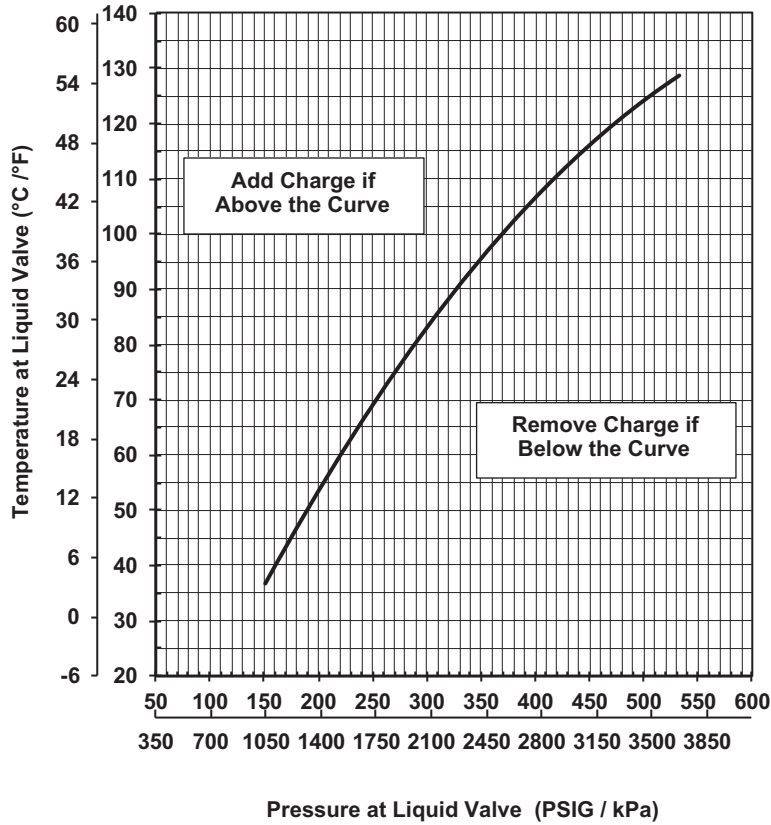

Fig. 26 — 38AUD\*16 Charging Chart

20 Ton Circuit A Charging Chart R-410A Refrigerant



38AU500734 D

20 Ton Circuit B Charging Chart R-410A Refrigerant

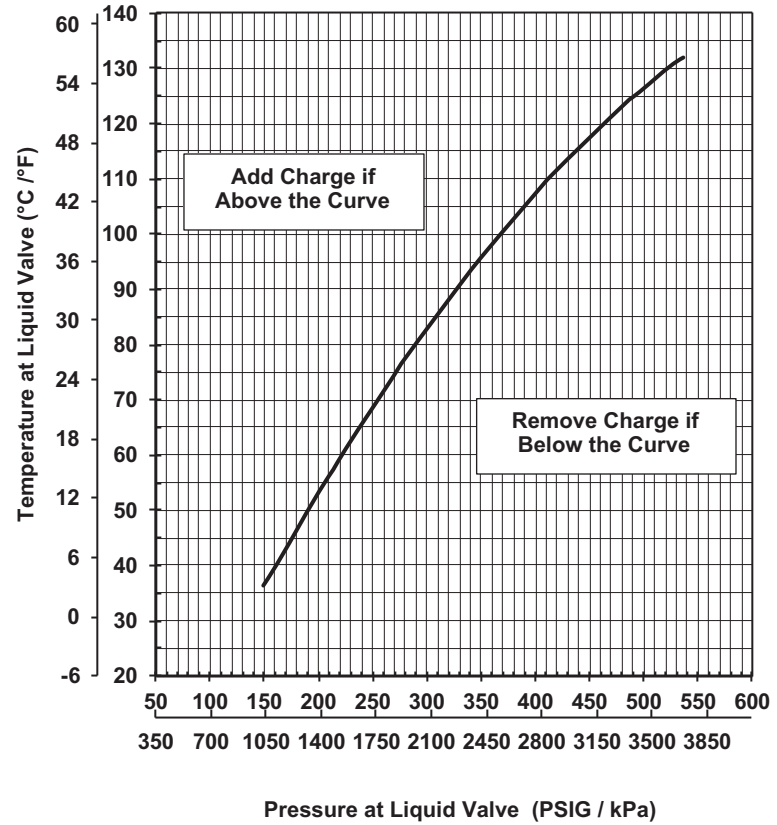

38AU500734 D

Fig. 27 — 38AUD\*25 Charging Chart

### 25 Tons Circuit A R-410A CHARGING CHART

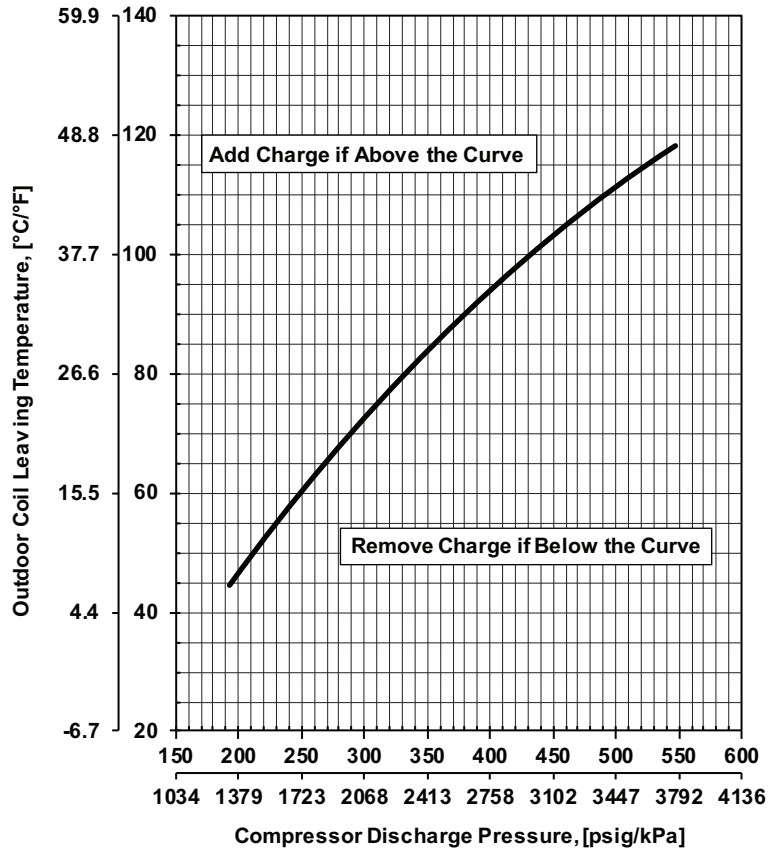

38AU001206 Rev. -

### 25 Tons Circuit B R-410A CHARGING CHART

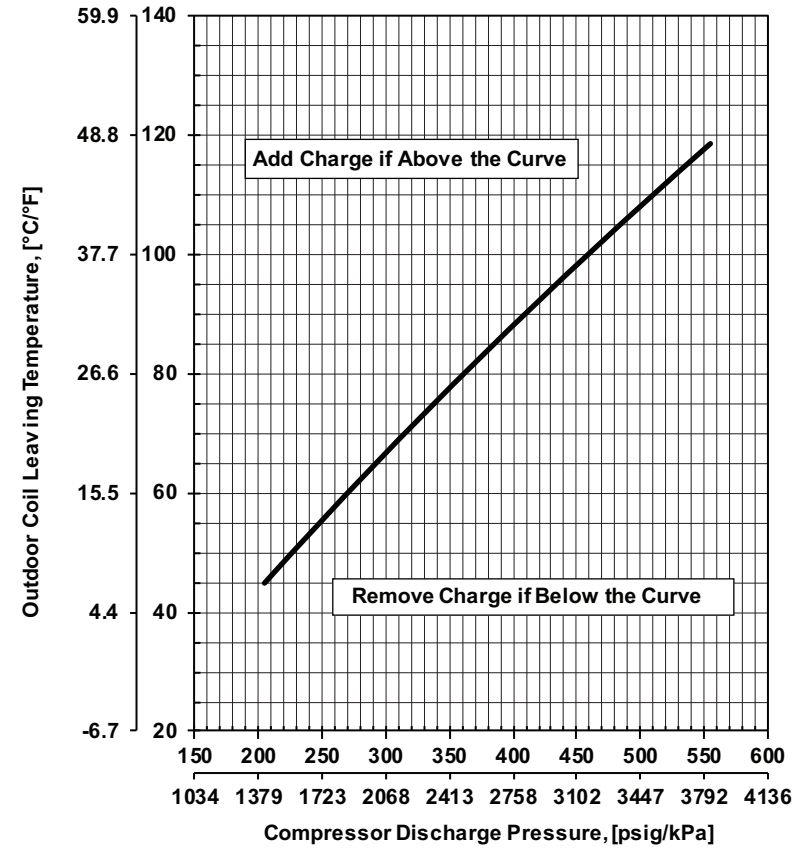

38AU001206 Rev. -

Fig. 28 — 38AUD\*28 Charging Chart

## OPERATING SEQUENCE

### Base Unit Controls

#### INDOOR (SUPPLY) FAN

If the thermostat fan operation is selected as Continuous the indoor (supply) fan motor runs continuously. If the thermostat fan operation is selected as Automatic, the indoor (supply) fan motor runs when there is a call for cooling, heating, or ventilation. When thermostat call for Cooling is satisfied the indoor (supply) fan motor stops. If there is a fan fault or shutdown condition in the fan coil, the indoor (supply) fan will not run if there is a call for ventilation, cooling, or heating, and the 38AU unit will act as if it is not receiving a cooling demand.

#### COOLING, UNIT WITHOUT ECONOMIZER

##### **38AUZ (Single Circuit)**

On a thermostat call for Cooling the indoor (supply) fan motor runs (subject to there being no fan fault or shutdown condition, see above section). Thermostat output Y1 is energized; terminal Y1 at 38AUZ unit receives 24-v. 24-v received at CADM1 terminal Y. If anti-recycle time delay period has not expired, CADM1 relay will remain open, de-energizing Solenoid Valve Relay (SVR) and preventing compressor start. When safety pressure switches are closed and CADM1 time delay expires, CADM1 relay closes, SVR and compressor contactor C1 are energized; liquid line solenoid valve LLSV opens, all outdoor fan motors start and Compressor 1 starts.

On a thermostat calling for Stage 2 Cooling, thermostat output Y2 is energized; terminal Y2 at 38AUZ unit receives 24-v. 24-v is received at CADM2 terminal Y. If anti-recycle time delay period has not expired, CADM2 relay will remain open, preventing Compressor 2 start. When safety pressure switches are closed and CADM2 time delay expires, CADM2 relay closes, compressor contactor C2 is energized; Compressor 2 starts.

As space cooling load is satisfied, thermostat outputs Y2 and Y1 are sequentially de-energized, removing 24-v at 38AUZ terminals Y2 and Y1. Compressor 2 stops on Y2 opening. CADM2 begins its three-minute anti-recycle time delay. On Y1 opening, Compressor 1 stops, all outdoor fan motors stop and SVR relay is de-energized. Liquid line solenoid valve is de-energized and valve closes. CADM1 begins its three-minute anti-recycle time

##### **38AUD(T,U) (Two Circuits/3-Stage Cooling)**

On a thermostat call for Cooling the indoor (supply) fan motor runs. Thermostat output Y1 is energized; terminal Y1 at 38AUD unit receives 24-v and the Compressor Lockout Relay (CLR) is energized (if there is a fan fault or shutdown condition in the fan coil unit, the CLR will not energize, preventing a Y1, Y2, or Y3 call from turning on the compressors). 24-v is received at CADM1 terminal Y1. If anti-recycle time delay period has not expired, CADM1 relay will remain open, de-energizing Solenoid Valve Relay 1 (SVR1) and preventing compressor start. When safety pressure switches are closed and CADM1 time delay expires, CADM1 relay closes, SVR1 and compressor contactor C1 are energized; liquid line solenoid valve LLSV1 opens and Circuit 1 compressor starts. All outdoor fan motors start if the outdoor temperature is above  $60^{\circ}\pm 1.5^{\circ}\text{F}$  or outdoor fan motor 2 starts if the outdoor temperature is below  $55^{\circ}\pm 1.5^{\circ}\text{F}$ .

On a thermostat calling for Stage 2 Cooling, thermostat output Y2 is energized; terminal Y2 at 38AUD unit receives 24-v. 24-v received at CADM2 terminal Y. If anti-recycle time delay period has not expired, CADM2 relay will remain open, de-energizing Solenoid Valve Relay 2 (SVR2) and preventing compressor start. When safety pressure switches are closed and CADM2 time delay expires, CADM2 relay closes, SVR2 and compressor contactor C2 are energized; liquid line solenoid valve LLSV2 opens and Circuit 2 compressor starts.

On a thermostat calling for Stage 3 Cooling, thermostat output Y3 is energized; terminal X at 38AUD unit receives 24-v. 24-v is

received at CADM1 terminal Y2. CADM1 DC SOL terminal outputs 24-vdc to the compressor loader plug (LDR) and the Compressor 1 operates at full load capacity.

As space cooling load is satisfied, thermostat outputs Y3, Y2 and Y1 are de-energized, removing 24-v at 38AUD terminals X (Y3), Y2 and Y1. Compressor 2 loader plug is de-energized on Y3 opening. Circuit 2 compressor stops on Y2 opening; SVR2 is de-energized and LLSV2 closes. CADM2 begins its three-minute anti-recycle time delay. On Y1 opening, Circuit 1 compressor stops, all outdoor fan motors stop and SVR1 relay is de-energized. Liquid line solenoid valve LLSV1 is de-energized and valve closes. Compressor Lockout Relay is also de-energized. CADM1 begins its three-minute anti-recycle time delay.

#### FAN CYCLING

38AUD(T,U)16-28 units are equipped with a temperature switch that will shut down Outdoor Fans 2 and 4 in cooling mode when the outdoor temperature falls below  $55^{\circ}\text{F}$  ( $13^{\circ}\text{C}$ ) to ensure continuous operation in both stages. The outdoor fan will turn back on when the temperature rises above  $60^{\circ}\text{F}$  ( $16^{\circ}\text{C}$ ). See Fig. 30 and 34 for outdoor fan labeling.

### All Units

If either the Low Pressure Switch or High Pressure Switch opens while thermostat output Y1 or Y2 remain energized, the compressor contactor is de-energized, the compressor stops and liquid line solenoid is de-energized (valve closes). CADM initiates a TRIP event (cooling demand sensed at CADM terminal Y but no current is measured at T1, T2, T3 motor sensors); CADM relay opens and RED LED is illuminated. TRIP condition maintains lockout of compressor operation until CADM is manually reset. Reset CADM by cycling unit main power.

Complete system shutdown may be caused by loss of main power, open compressor internal overload, open low-pressure or high-pressure switch, or a fault detected by the CADM logic. Compressor operation without cooling may indicate the compressor's ASTP feature is active; disconnect unit power and allow compressor to cool. See Service section for further details.

#### COOLING, UNIT WITH ECONOMIZER

Refer to fan coil unit installation instructions and economizer accessory installation instructions for operating sequences when system is equipped with accessory economizer.

#### HEATING

Refer to fan coil unit installation instructions and accessory heating device installation instructions for operating sequences in heating mode.

## MAINTENANCE

These items should be part of a routine maintenance program, to be checked every month or two, until a specific schedule for each can be identified for this installation:

### Quarterly Inspection (and 30 days after initial start)

#### INDOOR SECTION

- Condenser coil cleanliness checked.
- Return air filter replacement
- Outdoor hood inlet filters cleaned
- Belt tension checked
- Belt condition checked
- Pulley alignment checked
- Fan shaft bearing locking collar tightness checked
- Condensate drain checked

## Heating

- Power wire connections
- Fuses ready
- Manual-reset limit switch is closed

## Seasonal Maintenance

These items should be checked at the beginning of each season (or more often if local conditions and usage patterns dictate):

### AIR CONDITIONING

- Condenser fan motor mounting bolts tightness
- Compressor mounting bolts
- Condenser fan blade positioning
- Control box cleanliness and wiring condition
- Wire terminal tightness
- Refrigerant charge level
- Evaporator coil cleaning
- Evaporator blower motor amperage

### Economizer or Outside Air Damper

- Inlet filters condition
- Check damper travel (economizer)
- Check gear and dampers for debris and dirt

See Tables 16 and 17 for unit specific maintenance checklists.

**Table 16 — Outdoor Unit Maintenance Checklist**

MAINTENANCE CHECKLIST <sup>a</sup>	RECOMMENDED INTERVAL <sup>b</sup>	
	Monthly	Annual
<b>Outdoor unit specific:</b>		
Clear away debris and vegetation near unit.	X	
Inspect cabinet for damage. Replace components that are damaged or severely rusted.		X
Inspect electrical disconnect for proper function. Repair or replace as necessary.		X
Inspect electrical wiring and connections. Tighten loose connections. Inspect and perform functional test of equipment as needed to ensure proper function. Repair or replace damaged or overheated components and wiring.		X
Check refrigerant system subcooling and superheat.		X
Inspect inside of unit. Clean if debris is present.		X
Inspect condenser coil. Clean if dust, dirt, or debris is present. Rinse unit with fresh water. <sup>c</sup>		X <sup>d</sup>
Inspect motor and fan for damage. Make sure fans spin freely.		X

#### NOTE(S):

- The above list may not include all maintenance items. Inspection intervals may vary depending on climate and opening hours. Consult your Carrier dealer about a service contact for seasonal inspections
- Monthly maintenance items and outdoor unit rinsing may be performed by the customer. All other maintenance items and all service work must be performed by a qualified service technician. Read all warning labels.
- Do not use harsh chemicals or high pressure water on coils. More frequent rinsing is required near a sea coast.
- Monthly rinsing of the condenser coil is recommended if the unit is located in a corrosive climate.

**Table 17 — Indoor Unit Maintenance Checklist**

MAINTENANCE CHECKLIST <sup>a</sup>	RECOMMENDED INTERVAL <sup>b</sup>	
	Monthly	Annual
<b>Indoor unit specific: (for accessories refer to unit specific literature)</b>		
Inspect, clean, or replace air filter if dirty.	X	
Inspect and clean blower assembly (includes blower housing, wheel, and motor). Lubricate shaft bearings.		X
Inspect internal and external cabinet. Clean as needed.		X
Inspect electrical disconnect for proper function. Repair or replace as necessary.		X
Inspect electrical components, wiring, and connections. Tighten loose connections. Repair or replace damaged components and wiring.		X
Inspect evaporator coil. Clean if dust, dirt, or debris is present. <sup>c</sup>		X
Clean condensate pan, trap, and drain lines (more frequent maintenance may be required in humid climates - consult your local HVAC dealer).		X
Inspect motor and fan for damage. Make Inspect airflow system (ductwork). Check for leaks and repair as needed.		X

#### NOTE(S):

- The above list may not include all maintenance items. Inspection intervals may vary depending on climate and opening hours. Consult your Carrier dealer about a service contact for seasonal inspections
- Monthly maintenance items and outdoor unit rinsing may be performed by the customer. All other maintenance items and all service work must be performed by a qualified service technician. Read all warning labels.
- Do not use harsh chemicals or high pressure water on coils. More frequent rinsing is required near a sea coast.

## SERVICE

### Refrigeration System

#### WARNING

##### UNIT OPERATION AND SAFETY HAZARD

Failure to follow this warning could cause personal injury, death and/or equipment damage.

This system uses R-410A refrigerant, which has higher pressures than R-22 and other refrigerants. No other refrigerant may be used in this system. Gauge set, hoses, and recovery system must be designed to handle R-410A refrigerant. If unsure about equipment, consult the equipment manufacturer.

### COMPRESSOR OIL

#### CAUTION

##### UNIT DAMAGE HAZARD

Failure to follow this caution may result in damage to components.

The compressor is in a R-410A refrigerant system and uses a polyolester (POE) oil. This oil is extremely hygroscopic, meaning it absorbs water readily. POE oils can absorb 15 times as much water as other oils designed for HCFC and CFC refrigerants. Avoid exposure of the oil to the atmosphere.

### Servicing Systems on Roofs with Synthetic Materials

POE (polyolester) compressor lubricants are known to cause long term damage to some synthetic roofing materials. Exposure, even if immediately cleaned up, may cause embrittlement (leading to cracking) to occur in one year or more. When performing any service which may risk exposure of compressor oil to the roof, take

appropriate precautions to protect roofing. Procedures which risk oil leakage include but are not limited to compressor replacement, repairing refrigerants leaks, replacing refrigerant components such as filter drier, pressure switch, metering device, coil, accumulator, or reversing valve.

**Synthetic Roof Precautionary Procedure:**

1. Cover extended roof working area with an impermeable polyethylene (plastic) drop cloth or tarp. Cover an approximate 10 x 10 ft (3.3 x 3.3 m) area.
2. Cover area in front of the unit service panel with a terry cloth shop towel to absorb lubricant spills and prevent run-offs, and protect drop cloth from tears caused by tools or components.
3. Place terry cloth shop towel inside unit immediately under component(s) to be serviced and prevent lubricant run-offs through the louvered openings in the base pan.
4. Perform required service.
5. Remove and dispose of any oil contaminated material per local codes.

**LIQUID LINE FILTER DRIER**

The factory-provided filter drier is specifically designed to operate with Puron refrigerant. Replace the filter drier with factory-authorized components only with a filter drier with desiccant made from 100% molecular sieve grade XH-11. Filter drier must be replaced whenever the refrigerant system is opened.

When removing a filter drier, use a tubing cutter to cut the drier from the system. Do not unsweat a filter drier from the system. Heat from unsweating will release moisture and contaminants from drier into system.

**FIELD REFRIGERANT ACCESS PORTS**

Field service access to refrigerant pressures is through the access ports located at the service valves (see Fig. 30-37). These ports are 1/4-in. SAE Flare couplings with Schrader check valves and service caps. Use these ports to admit nitrogen to the field tubing during brazing, to evacuate the tubing and evaporator coil, to admit initial refrigerant charge into the low-side of the system and when checking and adjusting the system refrigerant charge. When service activities are completed, ensure the service caps are in place and secure; check for leaks. If the Schrader check valve must be removed and re-installed, tighten to 2 to 3 in.-lb (23 to 34 N-cm).

**FACTORY HIGH-FLOW ACCESS PORTS**

There are two additional access ports in the system - on the suction tube between the compressor and the suction service valve and on the liquid tube near the liquid service valve (see Fig. 31 and 35). These are brass fittings with black plastic caps. The hose connection fittings are standard 1/4-in. SAE Male Flare couplings.

The brass fittings are two-piece High Flow valves, with a receptacle base brazed to the tubing and an integral spring-closed check valve core screwed into the base. (See Fig. 31.) This check valve is permanently assembled into this core body and cannot be serviced separately; replace the entire core body if necessary. Service tools are available from RCD that allow the replacement of the check valve core without having to recover the entire system refrigerant charge. Apply compressor refrigerant oil to the check valve core's bottom o-ring. Install the fitting body with 96 ±10 in.-lb (1085 ±23 N-cm) of torque; do not overtighten.

**Comfort Alert Diagnostic Module**

The Comfort Alert Diagnostic Module (CADM) monitors and analyzes data from the Copeland Scroll three-phase compressor and the thermostat demand. The CADM also provides a 3-minute anti-recycle time delay to compressor cycling. Each compressor has a separate CADM module.

The CADM detects causes for electrical and system related failures without any sensors. Flashing LEDs communicate the Alert codes to guide service technicians in accurately and quickly troubleshooting the system and determining root cause for the failure.

Inputs to the CADM include 24-vac power, thermostat Y1 or Y2, compressor contactor coil (common side) and compressor power leads (from the compressor contactor). See Table 18.

Control of the compressor contactor coil is through a normally-closed (power on the module) contact between terminals P and C.

**Table 18 — Comfort Alert Diagnostic Module Inputs**

INPUT	TERMINAL	VOLTAGE
Control Power	R	24-v
Demand <sup>a</sup>	Y2	24-v
Control Common	C	24-v
Cooling	Y	24-v
Contractor Coil	P	24-v
Line A	T1	Line
Line B	T2	Line
Line C	T3	Line

NOTE(S):

a. Only applies to 38AUZ.

Communications of status and alert conditions is through three LEDs located on the top edge of the module housing (see Fig. 29): POWER (green), ALERT (yellow), and TRIP (red).

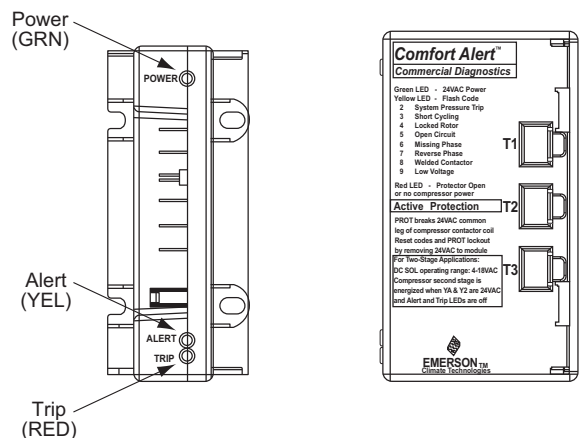

**Fig. 29 — CADM Housing/LED Locations**

The POWER LED indicates the presence of control power to the CADM.

The ALERT LED indicates an abnormal condition exists in the system through a flash code. The ALERT LED will blink a number of times consecutively, pause and the repeat the process. The number of blinks, defined in Table 19, correlates to a particular abnormal condition; troubleshooting tips are provided for each Alert code. Reset of the ALERT may be automatic or manual. If the fault condition causing the Alert is self-corrected, the Alert code will be removed and the CADM will automatically reset and allow the system to restart normally. Manual reset requires that main power to the 38AU unit be recycled after the cause for the Alert condition has been detected and corrected.

The TRIP LED indicates either a time-delay period is currently active (RED LED is blinking) or the module has locked out the compressor (RED LED is on steady). A lockout condition will occur when the CADM detects a thermostat demand at input Y but there is no power at the compressor line terminals T1 or T2 or T3. This lockout can occur due to a safety switch (LPS or HPS) opening and de-energizing the compressor contactor, the compressor-motor internal overload opens, or other internal power interruption has occurred. Reset of the TRIP LED requires that unit main power be recycled after the loss of power to the compressor condition has been detected and corrected.



Simultaneous blinking of YELLOW and RED LEDs indicates control power input to the CADM is low. Check control circuit transformer and wiring.

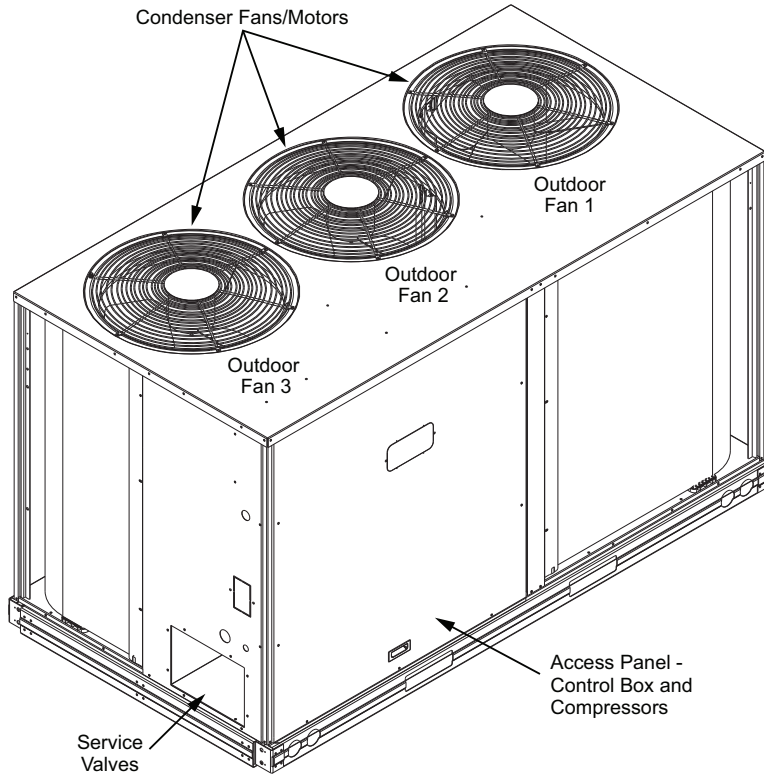

**Fig. 30 — 38AUD Size 16 Cabinet**

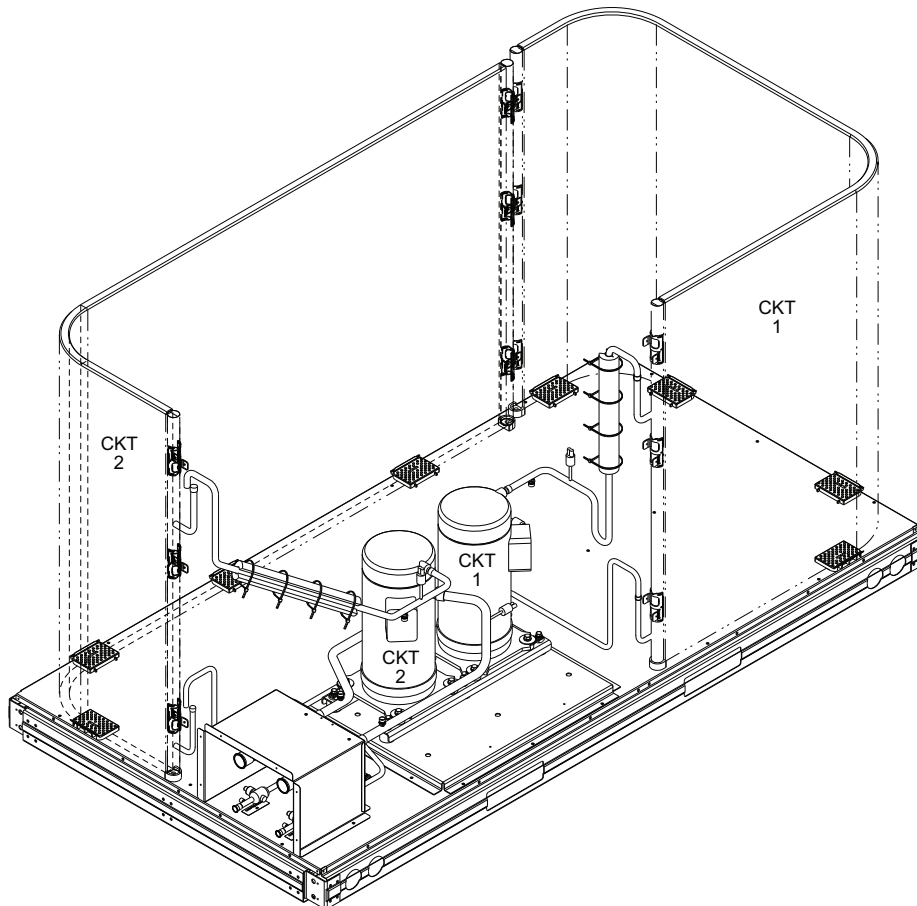

**Fig. 31 — 38AUD\*16 Piping**

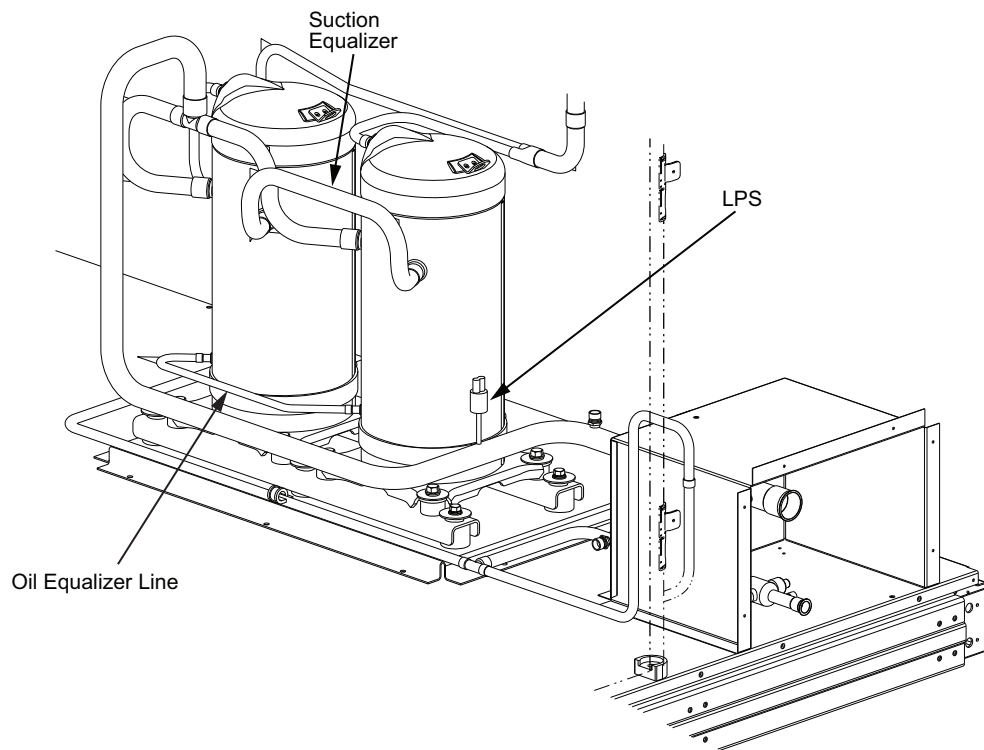

**Fig. 32 — 38AUZ\*16 Compressor Assembly (Rear View)**

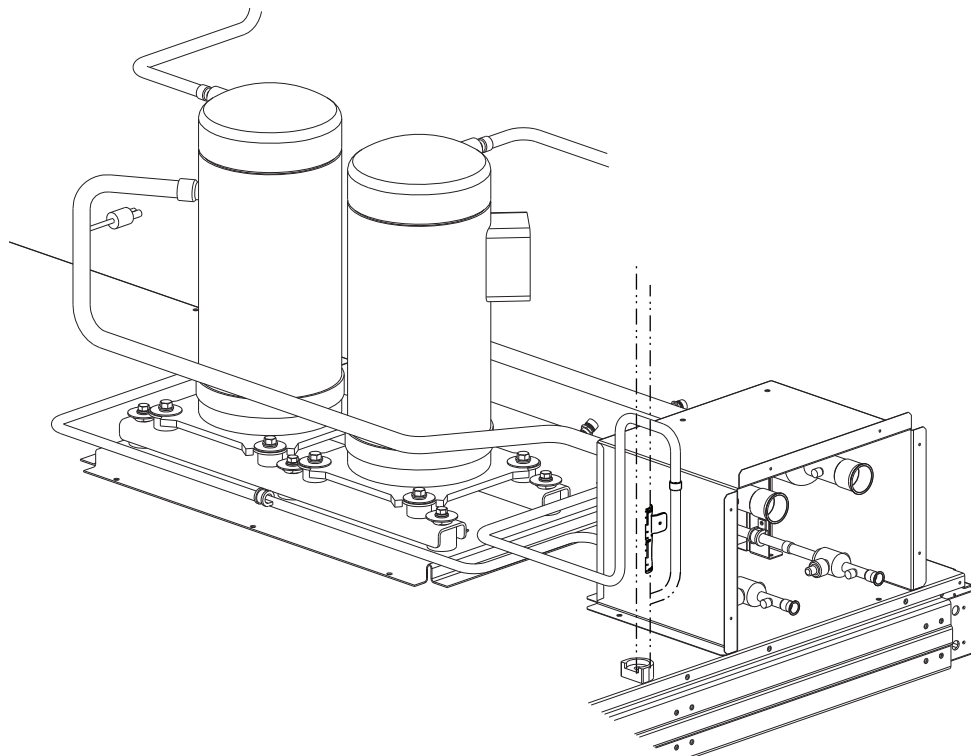

**Fig. 33 — 38AUD\*16 Compressor Assembly (Rear View)**

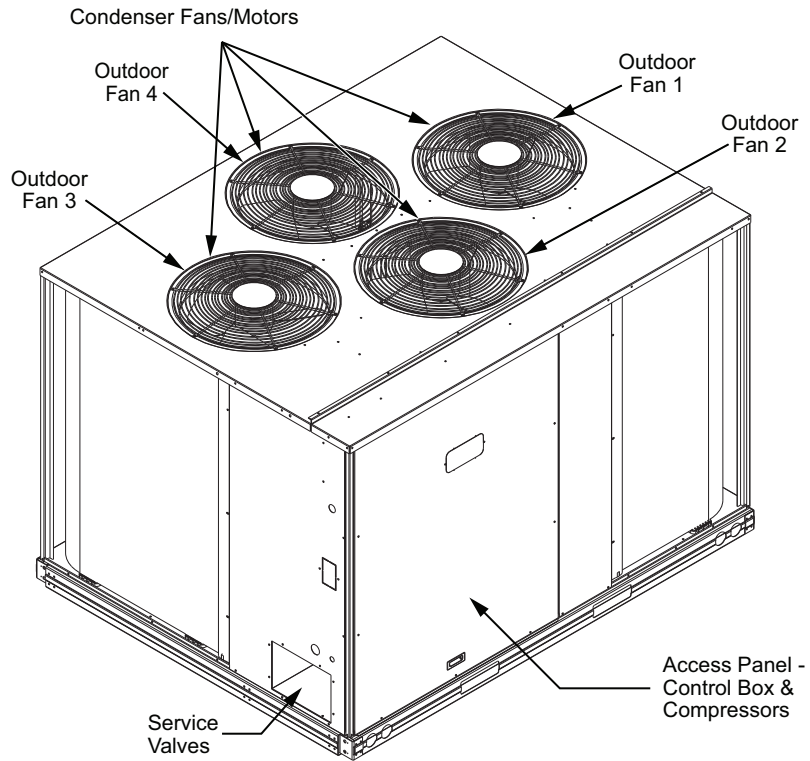

**Fig. 34 — 38AUZ,D Size 25 Cabinet**

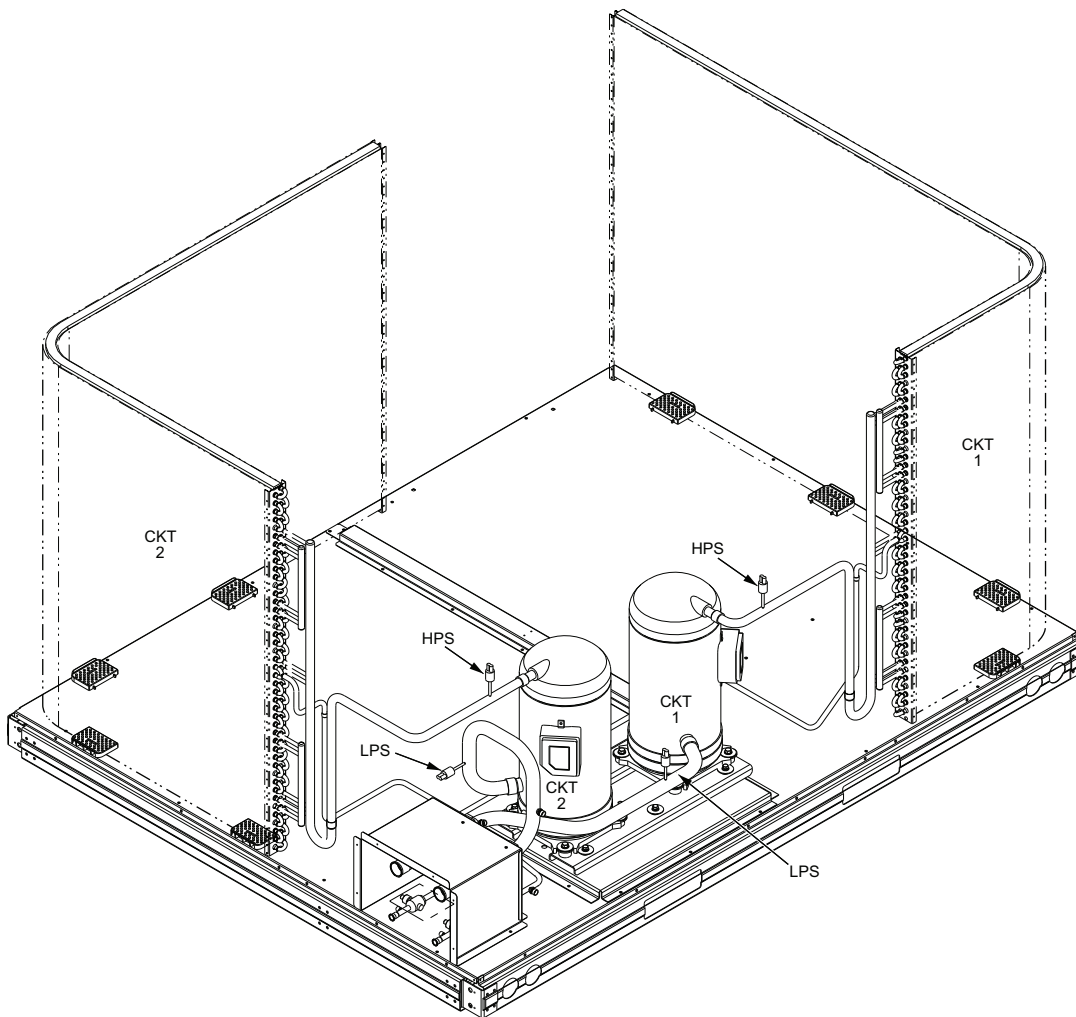

**Fig. 35 — 38AUD\*25 Piping**

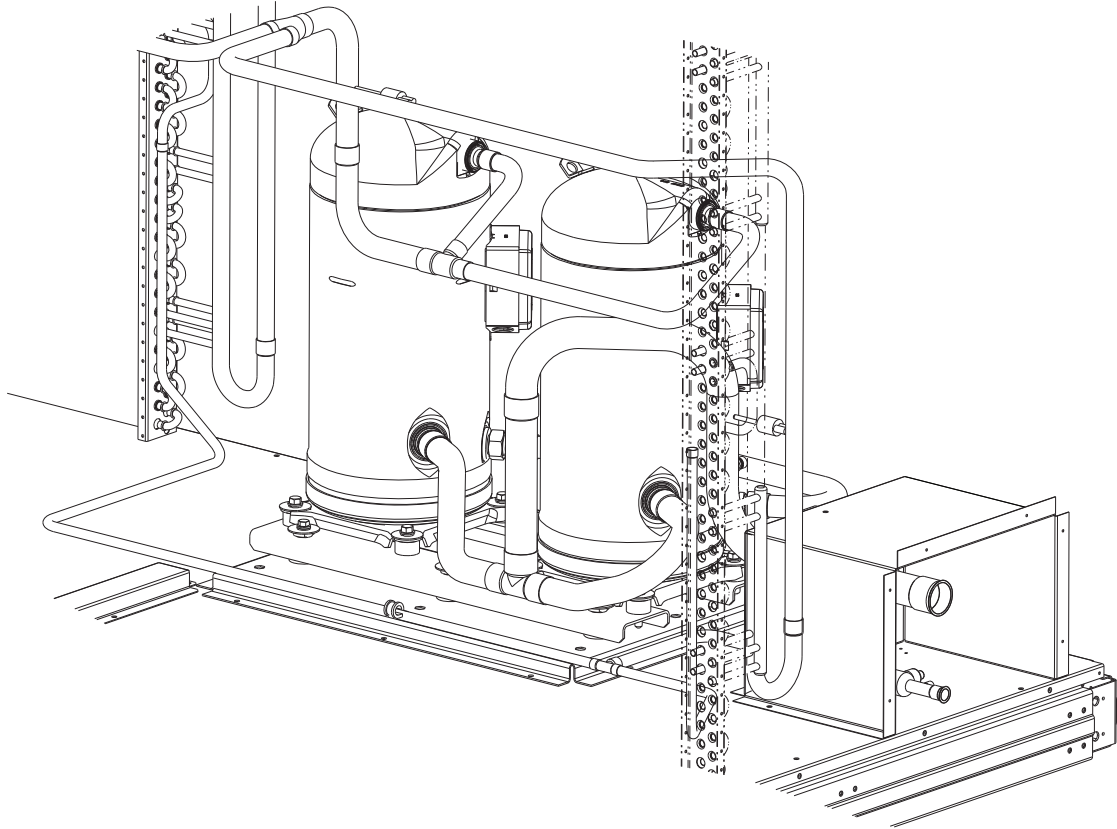

**Fig. 36 — 38AUZ\*25 Compressor Assembly (Rear View)**

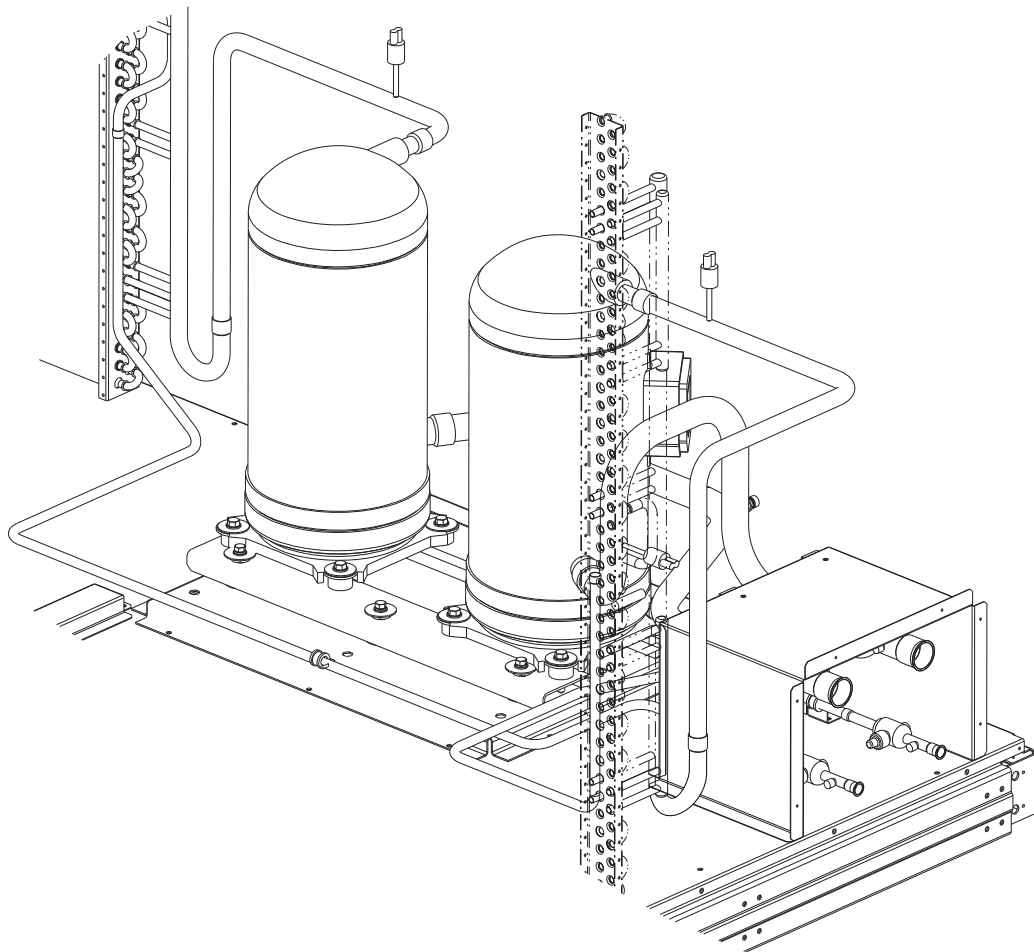

**Fig. 37 — 38AUD\*25 Compressor Assembly (Rear View)**

## TROUBLESHOOTING THE CADM WIRING

Flashing LEDs also indicate wiring problems to the CADM. See Tables 19 and 20 for discussion of additional LED flash codes and troubleshooting instructions.

**Table 19 — LED Status Codes**

STATUS LED	STATUS LED DESCRIPTION	STATUS LED TROUBLESHOOTING INFORMATION
Green "POWER"	Module has power	Supply voltage is present at module terminals
Red "TRIP" LED On Solid	Thermostat demand signal Y is present, but the compressor is not running.	<ol style="list-style-type: none"> <li>1. Compressor protector is open</li> <li>2. Condensing unit power disconnect is open</li> <li>3. Compressor circuit breaker or fuse(s) is open</li> <li>4. Broken supply wires or connector is not making contact</li> <li>5. Compressor power wires not routed through Comfort Alert</li> <li>6. Compressor contactor has failed open</li> </ol>
Red "TRIP" LED Flashing	The anti-short cycle timer (3 minutes) in module is preventing compressor restart.	
Module locks out compressor when compressor damaging ALERT code appears. Lockout ALERT codes are noted in the Status LED Description. During a compressor lock out, 24VAC power must be removed from module to manually reset.		
Yellow "ALERT" LED On Solid	A short circuit or over current condition exists on PROT terminal.	<ol style="list-style-type: none"> <li>1. Compressor contactor coil shorted</li> <li>2. Electrical load too high for PROT circuit (maximum 1 Amp)</li> <li>3. 24 V AC wired directly to PROT terminal</li> </ol>
Yellow "ALERT" Flash Code 2	System Pressure Trip Discharge pressure out of limits LOCKOUT	<ol style="list-style-type: none"> <li>1. High head pressure</li> <li>2. Condenser coil poor air circulation (dirty, blocked, damaged)</li> <li>3. Condenser fan is not running</li> <li>4. If low pressure switch is open:               <ol style="list-style-type: none"> <li>a. Low refrigerant charge</li> <li>b. Evaporator blower is not running</li> <li>c. Evaporator coil is frozen</li> <li>d. Faulty metering device</li> <li>e. Condenser coil is dirty</li> <li>f. Liquid line restriction (filter drier blocked if present)</li> </ol> </li> </ol>
Yellow "ALERT" Flash Code 3	Short Cycling Compressor is running only briefly (four consecutive cycles of less than three minutes each) LOCKOUT	<ol style="list-style-type: none"> <li>1. Loose connection between thermostat Y1 and CADM Y terminal.</li> <li>2. Unit short-cycling on thermostat</li> <li>3. System or control board defective</li> </ol>
Yellow "ALERT" Flash Code 4	Locked Rotor LOCKOUT	<ol style="list-style-type: none"> <li>1. Low line voltage to compressor</li> <li>2. Excessive liquid refrigerant in compressor</li> <li>3. Compressor bearings are seized</li> </ol>
Yellow "ALERT" Flash Code 5	Open Circuit	<ol style="list-style-type: none"> <li>1. Condensing unit power disconnect is open</li> <li>2. Compressor circuit breaker or fuses are open</li> <li>3. Compressor contactor has failed open</li> <li>4. High pressure switch is open and requires manual reset</li> <li>5. Broken supply wires or connector is not making contact</li> <li>6. Unusually long compressor protector reset time due to extreme ambient temperature</li> <li>7. Compressor windings are damaged</li> </ol>
Yellow "ALERT" Flash Code 6	Missing Phase LOCKOUT	<ol style="list-style-type: none"> <li>1. Compressor fuse is open on one phase</li> <li>2. Broken wire or connector on one phase</li> <li>3. Compressor motor winding is damaged</li> <li>4. Utility supply has dropped one phase</li> </ol>
Yellow "ALERT" Flash Code 7	Reverse Phase LOCKOUT	<ol style="list-style-type: none"> <li>1. Compressor running backward due to supply phase reversal</li> </ol>
Yellow "ALERT" Flash Code 8	Welded Contractor Compressor always runs	<ol style="list-style-type: none"> <li>1. Compressor contactor has failed closed</li> <li>2. Thermostat demand signal not connected to module</li> </ol>
Yellow "ALERT" Flash Code 9	Low Voltage Control circuit < 18VAC	<ol style="list-style-type: none"> <li>1. Control circuit transformer is overloaded</li> <li>2. Low line voltage to compressor</li> </ol>

**Table 20 — CADM Troubleshooting**

MISWIRED MODULE INDICATION	RECOMMENDED TROUBLESHOOTING ACTION
Green LED is not on, module does not power up	Determine if both R and C module terminals are connected. Verify voltage is present at module's R and C terminals. NOTE: The CADM requires a constant nominal 24VAC power supply. The wiring to the module's R and C terminals must be directly from the control transformer. The module cannot receive its power from another device that will interrupt the 24VAC power supply. See Appendix B Wiring Diagrams.
Green LED Intermittent, module powers up only when compressor runs	Determine if R and Y terminals are wired in reverse. Verify module's R and C terminals have a constant source. See "NOTE" above for details on R and C wiring.
TRIP LED is on but system and compressor check OK	Verify Y terminal is wired properly per the 38AU wiring diagram (see Appendix B Wiring Diagrams). Verify voltage at contactor coil falls below 0.5VAC when off. Verify 24VAC is present across Y and C when thermostat demand signal is present. If not, R and C are reverse wired.
TRIP LED and ALERT LED flashing together	Verify R and C terminals are supplied with 19-28VAC.
ALERT Flash Code 3 (Compressor Short Cycling) displayed incorrectly	Verify Y terminal is connected to 24VAC at contactor coil. Verify voltage at contactor coil falls below 0.5VAC when off.
ALERT Flash Code 5 or 6 (Open Circuit, Missing Phase) displayed incorrectly	Check that compressor T1 and T3 wires are through module's current sensing holes. Verify Y terminal is connected to 24VAC at contactor coil. Verify voltage at contactor coil falls below 0.5VAC when off.
Alert Flash Code 8 (Welded Contactor) displayed incorrectly	Determine if module's Y terminal is connected. Verify Y terminal is connected to 24VAC at contactor coil. Verify 24VAC is present across Y and C when thermostat demand signal is present. If not, R and C are reverse wired. Verify voltage at contactor coil falls below 0.5VAC when off.

## Compressor Protection

### COMPRESSOR OVER-TEMPERATURE PROTECTION (IP)

A thermostat installed on the compressor motor winding reacts to excessively high winding temperatures and shuts off the compressor.

### CRANKCASE HEATER

The heater minimizes absorption of liquid refrigerant by oil in the crankcase during brief or extended shutdown periods. The heater is wired to cycle with the compressor; the heater is off when compressor is running, and on when compressor is off.

The crankcase heater will operate as long as the power circuit is energized. The main disconnect must be on to energize the crankcase heater.

**IMPORTANT:** Never open any switch or disconnect that energizes the crankcase heater unless unit is being serviced or is to be shut down for a prolonged period. After a prolonged shutdown on a service job, energize the crankcase heater for 24 hours before starting the compressor.

### ADVANCED SCROLL TEMPERATURE PROTECTION (ASTP)

See "Advanced Scroll Temperature Protection (ASTP)" on page 21.

### LOW-PRESSURE SWITCH

The 38AU low-pressure switch is stem-mounted on the suction line. Switches are all fixed, non-adjustable type.

### HIGH-PRESSURE SWITCH

The high-pressure switch is stem mounted on the discharge line. The switch is a fixed, non-adjustable type.

### OUTDOOR FANS

Each fan is supported by a formed-wire mount bolted to the fan deck and covered with a wire guard. Fan motors have permanently lubricated bearings.

1. Shut off unit power supply. Install lockout tag.
2. Remove outdoor fan assembly (grille, motor, and fan).
3. Loosen fan hub setscrews.
4. Adjust fan height as shown in Fig. 38.
5. Tighten setscrews to 84 in.-lb (949 N-cm).

6. Replace outdoor fan assembly.

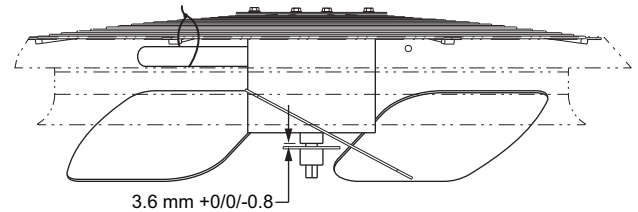

**Fig. 38 — Outdoor Fan Blade Position**

### LUBRICATION

#### Fan Motors

The fan motors have sealed bearings. No provisions are made for lubrication.

#### Compressor

The compressor has its own oil supply. Loss of oil due to a leak in the system should be the only reason for adding oil after the system has been in operation.

### Routine Cleaning of Round-Tube Plate Fin (RTPF) Coils

Periodic cleaning with Totaline® environmentally balanced coil cleaner is essential to extend the life of RTPF coils. This cleaner is available from Carrier Replacement parts division as part number P902-0301 for a one gallon container, and part number P902-0305 for a 5 gallon container. It is recommended that all RTPF coils be cleaned with the Totaline environmentally balanced coil cleaner as described below.

Coil cleaning should be part of the unit's regularly scheduled maintenance procedures to ensure long life of the coil. Failure to clean the coils may result in reduced durability in the environment.

Avoid the use of:

- coil brighteners
- acid cleaning prior to painting
- high pressure washers
- poor quality water for cleaning

Totaline environmentally sound coil cleaner is non-flammable, hypoallergenic, non-bacterial, and a USDA accepted biodegradable agent that will not harm the coil or surrounding components such as electrical wiring, painted metal surfaces, or insulation. Use of non-recommended coil cleaners is strongly discouraged since coil and unit durability could be affected.



## TOTALINE ENVIRONMENTALLY BALANCED COIL CLEANER APPLICATION EQUIPMENT

- 2-1/2 gallon garden sprayer
- water rinse with low velocity spray nozzle

### ⚠ CAUTION

#### UNIT DAMAGE HAZARD

Failure to follow this caution may result in accelerated corrosion of unit parts.

Harsh chemicals, household bleach or acid or basic cleaners should not be used to clean outdoor or indoor coils of any kind. These cleaners can be very difficult to rinse out of the coil and can accelerate corrosion at the fin/tube interface where dissimilar materials are in contact. If there is dirt below the surface of the coil, use the environmentally balanced coil cleaner.

**IMPORTANT:** High velocity water from a pressure washer, garden hose, or compressed air should never be used to clean a coil. The force of the water or air jet will bend the fin edges and increase airside pressure drop, resulting in reduced unit performance.

#### **Totaline Environmentally Sound Coil Cleaner Application Instructions:**

NOTE: Proper eye protection such as safety glasses is recommended during mixing and application.

1. Turn off unit power.
2. Remove screws holding rear corner post and top cover in place. Pivot top cover up 12 to 18 inches (305 to 457 mm) and support with a rigid support. See Fig. 39.

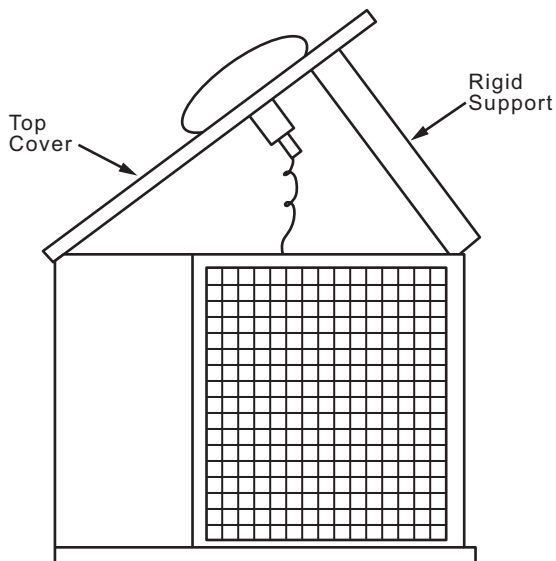

**Fig. 39 — Pivot and Support Top Cover**

3. Remove all surface loaded fibers and dirt with a vacuum cleaner. If a vacuum cleaner is not available, a soft non-metallic bristle brush may be used. In either case, the tool should be

applied in the direction of the fins. Coil surfaces can be easily damaged (fin edges can be easily bent over and damage to the coating of a protected coil) if the tool is applied across the fins.

NOTE: Use of a water stream, such as a garden hose, against surface loaded coil will drive the fibers and dirt into the coil, making cleaning efforts more difficult. Surface loaded fibers must be completely removed prior to using low velocity clean water rinse.

4. Using a low velocity garden hose thoroughly wet finned surfaces with clean water. Be careful not to bend the fins.
5. Mix Totaline environmentally balanced coil cleaner in a 2-1/2 gallon garden sprayer according to the instructions included with the cleaner. The optimum solution temperature is 100°F (38°C).

NOTE: Do NOT USE water in excess of 130°F (54°C), as the enzymatic activity will be destroyed.

6. Thoroughly apply Totaline environmentally balanced coil cleaner solution to all coil surfaces including the finned area, tube sheets and coil headers.
7. Hold garden sprayer nozzle close to finned areas and apply cleaner with a vertical, up-and-down motion. Avoid spraying in horizontal pattern to minimize potential for fin damage.
8. Ensure cleaner thoroughly penetrates deep into finned areas.
9. Interior and exterior finned areas must be thoroughly cleaned.
10. Finned surfaces should remain wet with cleaning solution for 10 minutes.
11. Ensure surfaces are not allowed to dry before rinsing. Reapply cleaner as needed to ensure 10-minute saturation is achieved.
12. Thoroughly rinse all surfaces with low velocity clean water using downward rinsing motion of water spray nozzle. Protect fins from damage from the spray nozzle.
13. Replace top cover and rear corner posts.

### Fastener Torque Values

See Table 21 for torque values.

**Table 21 — Torque Values**

ITEM	TORQUE VALUE
Compressor mounting bolts	65-75 in.-lb (734-847 N-cm)
Condenser fan motor mounting bolts	20 ± 2 in.-lb (226 ± 23 N-cm)
Condenser fan hub setscrew	84 ± 2 in.-lb (949 ± 136 N-cm)
High-flow service port	96 ± 10 in.-lb (1085 ± 23 N-cm)
Schrader-type service check valve	2-3 in.-lb (23-34 N-cm)
Compressor oil sight-glass thread	330 ± 31 in.-lb (23-34 N-cm)
Compressor to Compressor rail torque	120-168 in.-lb (1356-1898 N-cm)
Compressor rail to base pan torque	70 ± 5 in.-lb (791 ± 57 N-cm)

### TROUBLESHOOTING

See Table 22 for troubleshooting.



**Table 22 — Troubleshooting**

PROBLEM	SOLUTION
<p><b>COMPRESSOR DOES NOT RUN</b></p> <p><b>Contactors Open</b></p> <ol style="list-style-type: none"> <li>1. Power off.</li> <li>2. Fuses blown in field power circuit.</li> <li>3. No control power.</li> <li>4. Thermostat circuit open.</li> <li>5. Safety device lockout circuit active.</li> <li>6. Low-pressure switch open.</li> <li>7. High-pressure switch open</li> <li>8. Compressor over-temperature switch open.</li> <li>9. Loose electrical connections.</li> <li>10. Compressor stuck.</li> <li>11. Fan fault or shutdown condition in fan coil unit active, preventing thermostat signals passing from fan coil unit to 38AU.</li> </ol> <p><b>Contactors Closed</b></p> <ol style="list-style-type: none"> <li>1. Compressor leads loose.</li> <li>2. Motor windings open.</li> <li>3. Single phasing.</li> </ol>	<ol style="list-style-type: none"> <li>1. Restore power.</li> <li>2. After finding cause and correcting, replace with correct size fuse.</li> <li>3. Check control transformer primary connections and circuit breaker.</li> <li>4. Check thermostat setting.</li> <li>5. Reset lockout circuit.</li> <li>6. Check for refrigerant undercharge, obstruction of indoor airflow. Make sure liquid line solenoid valve(s) is open.</li> <li>7. Check for refrigerant overcharge, obstruction of outdoor airflow, air in system. Be sure outdoor fans are operating correctly</li> <li>8. Check for open condition. Allow for reset. Replace compressor if necessary.</li> <li>9. Tighten all connections.</li> <li>10. See compressor service literature.</li> <li>11. Reset fan limit switch (40RF) or address fault in VFD (40RU) or other shutdown condition.</li> </ol> <ol style="list-style-type: none"> <li>1. Check connections.</li> <li>2. See compressor service literature.</li> <li>3. Check for blown fuse. Check for loose connection at compressor terminal.</li> </ol>
<p><b>COMPRESSOR STOPS ON HIGH-PRESSURE SWITCH</b></p> <p><b>Outdoor Fan On</b></p> <ol style="list-style-type: none"> <li>1. High-pressure switch faulty.</li> <li>2. Reversed fan rotation.</li> <li>3. Airflow restricted.</li> <li>4. Air recirculating.</li> <li>5. Non-condensables in system.</li> <li>6. Refrigerant overcharge.</li> <li>7. Line voltage incorrect.</li> <li>8. Refrigerant system restrictions.</li> </ol> <p><b>Outdoor Fan Off</b></p> <ol style="list-style-type: none"> <li>1. Fan slips on shaft.</li> <li>2. Motor not running.</li> <li>3. Motor bearings stuck.</li> <li>4. Motor overload open.</li> <li>5. Motor burned out.</li> </ol>	<ol style="list-style-type: none"> <li>1. Replace switch.</li> <li>2. Confirm rotation, correct if necessary.</li> <li>3. Remove obstruction.</li> <li>4. Clear airflow area.</li> <li>5. Recover refrigerant and recharge as required.</li> <li>6. Recover refrigerant as required.</li> <li>7. Consult power company.</li> <li>8. Check or replace filter drier, expansion valve, etc.</li> </ol> <ol style="list-style-type: none"> <li>1. Tighten fan hub setscrews.</li> <li>2. Check power and capacitor.</li> <li>3. Replace bearings.</li> <li>4. Check overload rating. Check for fan blade obstruction.</li> <li>5. Replace motor.</li> </ol>
<p><b>COMPRESSOR CYCLES ON LOW-PRESSURE SWITCH</b></p> <p><b>Indoor-Air Fan Running</b></p> <ol style="list-style-type: none"> <li>1. Liquid line solenoid valve(s) fails to open.</li> <li>2. Filter drier plugged.</li> <li>3. Expansion valve power head defective.</li> <li>4. Low refrigerant charge.</li> </ol> <p><b>Airflow Restricted</b></p> <ol style="list-style-type: none"> <li>1. Coil iced up.</li> <li>2. Coil dirty.</li> <li>3. Air filters dirty.</li> <li>4. Dampers closed.</li> </ol> <p><b>Indoor-Air Fan Stopped</b></p> <ol style="list-style-type: none"> <li>1. Electrical connections loose.</li> <li>2. Fan relay defective.</li> <li>3. Motor overload open.</li> <li>4. Motor defective.</li> <li>5. Fan belt broken or slipping.</li> </ol>	<ol style="list-style-type: none"> <li>1. Check liquid line solenoid valve(s) for proper operation. Replace if necessary.</li> <li>2. Replace filter drier.</li> <li>3. Replace power head.</li> <li>4. Add charge. Check low-pressure switch setting.</li> </ol> <ol style="list-style-type: none"> <li>1. Check refrigerant charge.</li> <li>2. Clean coil fins.</li> <li>3. Clean or replace filters.</li> <li>4. Check damper operation and position.</li> </ol> <ol style="list-style-type: none"> <li>1. Tighten all connections.</li> <li>2. Replace relay.</li> <li>3. Power supply.</li> <li>4. Replace motor.</li> <li>5. Replace or tighten belt.</li> </ol>
<p><b>COMPRESSOR RUNNING BUT COOLING INSUFFICIENT</b></p> <p><b>Suction Pressure Low</b></p> <ol style="list-style-type: none"> <li>1. Refrigerant charge low.</li> <li>2. Head pressure low.</li> <li>3. Air filters dirty.</li> <li>4. Expansion valve power head defective.</li> <li>5. Indoor coil partially iced.</li> <li>6. Indoor airflow restricted.</li> </ol> <p><b>Suction Pressure High</b></p> <ol style="list-style-type: none"> <li>1. Heat load excessive.</li> </ol>	<ol style="list-style-type: none"> <li>1. Add refrigerant.</li> <li>2. Check refrigerant charge. Check outdoor-air fan thermostat settings.</li> <li>3. Clean or replace filters.</li> <li>4. Replace power head.</li> <li>5. Check low-pressure setting.</li> <li>6. Remove obstruction.</li> </ol> <ol style="list-style-type: none"> <li>1. Check for open doors or windows in vicinity of fan coil.</li> </ol>

**Table 22 — Troubleshooting (cont)**

<b>PROBLEM</b>	<b>SOLUTION</b>
<b>UNIT OPERATES TOO LONG OR CONTINUOUSLY</b> 1. Low refrigerant charge. 2. Control contacts fused. 3. Air in system. 4. Partially plugged expansion valve or filter drier.	1. Add refrigerant. 2. Replace control. 3. Purge and evacuate system. 4. Clean or replace.
<b>SYSTEM IS NOISY</b> 1. Piping vibration. 2. Compressor noisy.	1. Support piping as required. 2. Replace compressor if bearings are worn.
<b>COMPRESSOR LOSES OIL</b> 1. Leak in system. 2. Crankcase heaters not energized during shutdown. 3. Improper interconnecting piping design.	1. Repair leak. 2. Check wiring and relays. Check heater and replace if defective. 3. Check piping for oil return. Replace if necessary.
<b>FROSTED SUCTION LINE</b> 1. Expansion valve admitting excess refrigerant.	1. Adjust expansion valve.
<b>HOT LIQUID LINE</b> 1. Shortage of refrigerant due to leak. 2. Expansion valve opens too wide.	1. Repair leak and recharge. 2. Adjust expansion valve.
<b>FROSTED LIQUID LINE</b> 1. Restricted filter drier. 2. Liquid line solenoid valve partially closed.	1. Remove restriction or replace. 2. Replace valve.

NOTE(S):

a. On 38AUD 16-28 systems, Outdoor Fans 2 and 4 will be off in cooling mode below 55°F ±1.5°F outdoor temperature.

**APPENDIX A — AIR CONDITIONER AND HEAT PUMP WITH PURON® – QUICK REFERENCE GUIDE**

- Puron (R-410A) refrigerant operates at 50 percent to 70 percent higher pressures than R-22. Be sure that servicing equipment and replacement components are designed to operate with Puron refrigerant.
- Puron refrigerant cylinders are rose colored.
- Recovery cylinder service pressure rating must be 400 psig, DOT 4BA400 or DOT BW400.
- Puron systems should be charged with liquid refrigerant. Use a commercial type metering device in the manifold hose when charging into suction line with compressor operating.
- Manifold sets should be 700 psig high side and 180 psig low side with 550 psig low-side retard.
- Use hoses with 700 psig service pressure rating.
- Leak detectors should be designed to detect HFC refrigerant.
- Puron, as with other HFCs, is only compatible with POE oils.
- Vacuum pumps will not remove moisture from oil.
- Use only factory specified liquid-line filter driers with rated working pressures greater than 600 psig.
- Do not install a suction-line filter drier in liquid-line.
- POE oils absorb moisture rapidly. Do not expose oil to atmosphere.
- POE oils may cause damage to certain plastics and roofing materials.
- Wrap all filter driers and service valves with wet cloth when brazing.
- A factory approved, liquid-line filter drier is required on every unit.
- Do not use an R-22 TXV.
- If indoor unit is equipped with a TXV, it must be changed to a Puron TXV.
- Never open system to atmosphere while it is under a vacuum.
- When system must be opened for service, recover refrigerant, break vacuum with dry nitrogen before opening system.
- Always replace filter drier after opening system for service.
- Do not vent Puron refrigerant into the atmosphere.
- Do not use capillary tube coils.
- Observe all warnings, cautions, and bold text.
- All Puron heat pumps must have indoor TXV.
- Do not leave Puron suction line driers in place for more than 72 hours.

## APPENDIX B — WIRING DIAGRAMS

UNIT	ELECTRICAL CHARACTERISTICS	DIAGRAM NUMBER	PAGE NUMBER
<b>38AUD*16</b>	208/230-3-60	38AU501341	40
	460-3-60	38AU501340	41
	575-3-60	38AU501342	42
<b>38AUD*25</b>	208/230-3-60	38AU501337	43
	460-3-60	38AU501336	44
	575-3-60	38AU501338	45
<b>38AUD*28</b>	208/230-3-60	38AU501345	46
	460-3-60	38AU501344	47
	575-3-60	38AU501346	48
<b>38AUZ*16</b>	208/230-3-60	38AU500537	49
	460-3-60	38AU500538	50
	575-3-60	38AU500539	51
<b>38AUZ*25</b>	208/230-3-60	38AU500568	52
	460-3-60	38AU500569	53
	575-3-60	38AU500570	54

# APPENDIX B — WIRING DIAGRAMS (CONT)

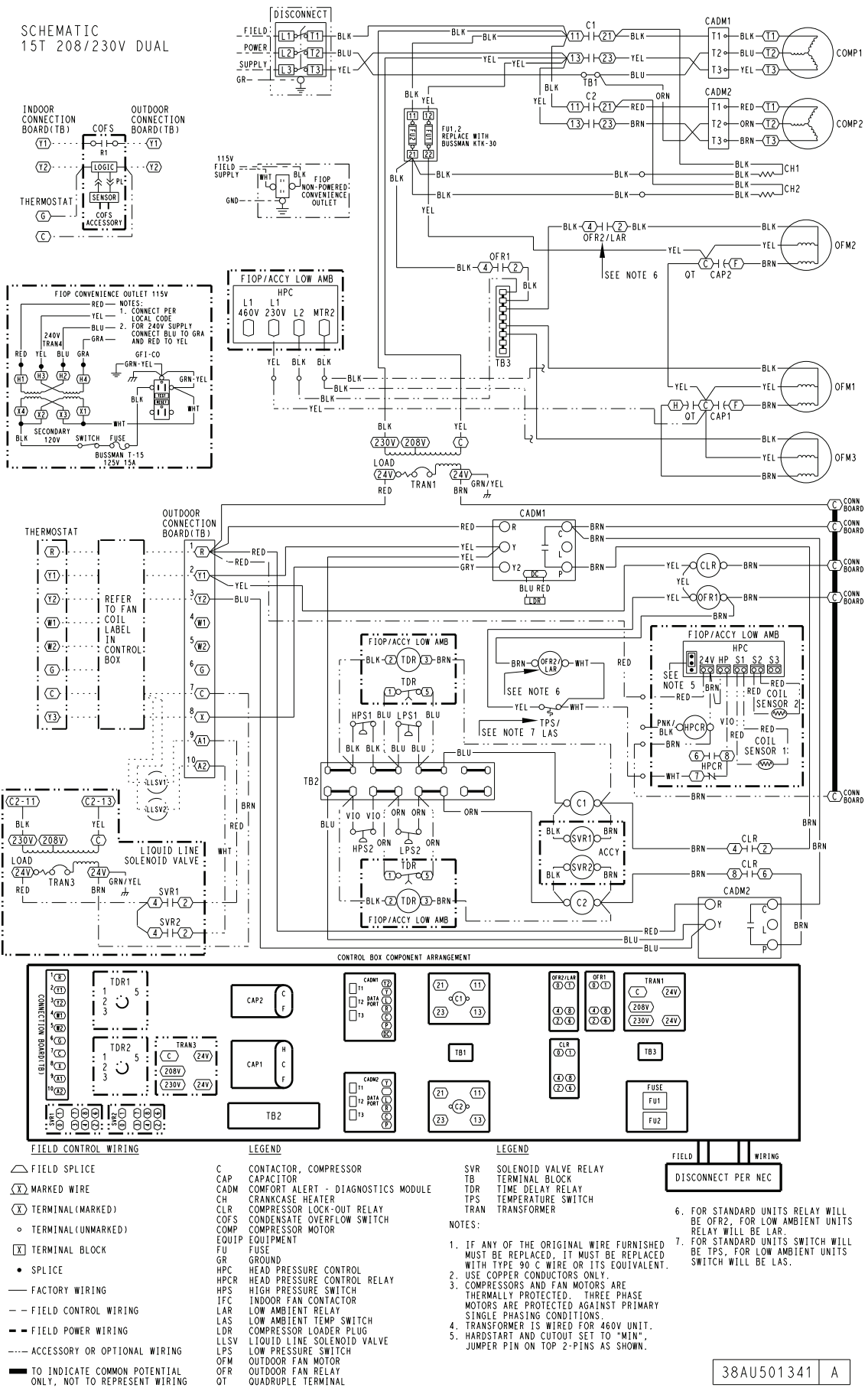

**Fig. A — Dual Circuit/Three Stage Wiring Diagram, 15 Ton — 208/230-3-60 Unit**

38AU501341 A

# APPENDIX B — WIRING DIAGRAMS (CONT)

SCHEMATIC  
15T 460V DUAL

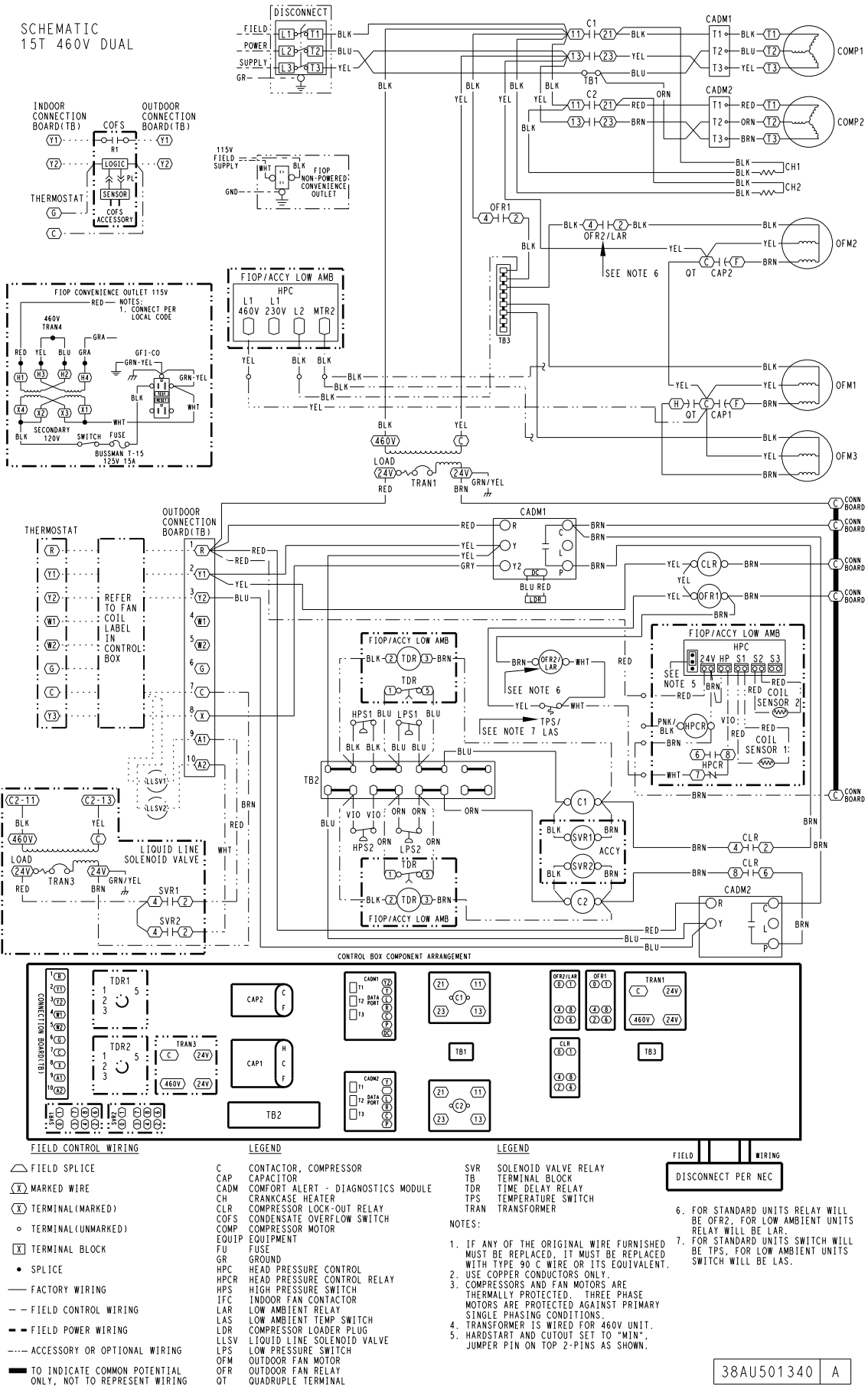
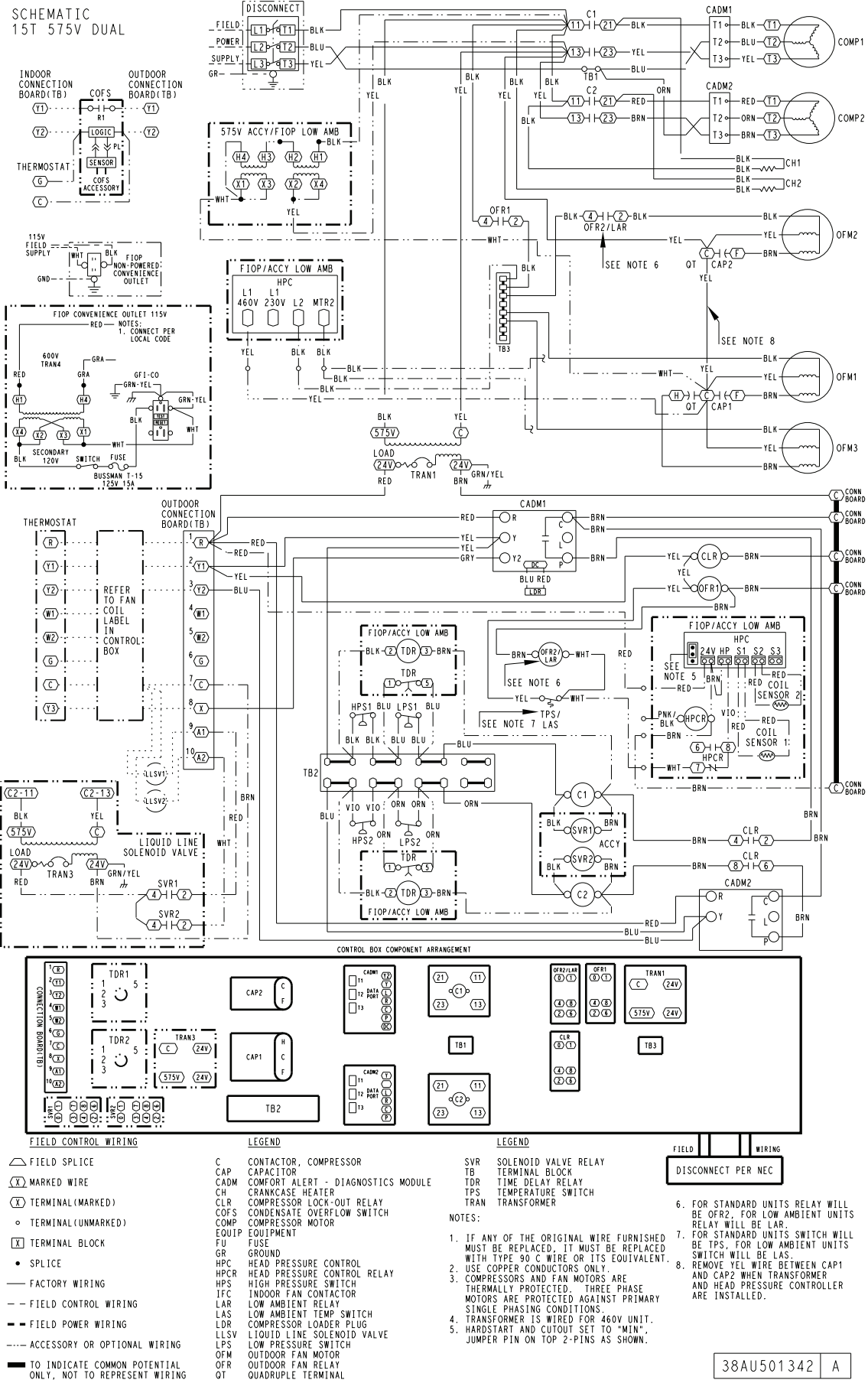

Fig. B — Dual Circuit/Three Stage Wiring Diagram, 15 Ton — 460-3-60 Unit

# APPENDIX B — WIRING DIAGRAMS (CONT)



**Fig. C — Dual Circuit/Three Stage Wiring Diagram, 15 Ton — 575-3-60 Unit**

# APPENDIX B — WIRING DIAGRAMS (CONT)

SCHEMATIC  
20T 208/230V DUAL

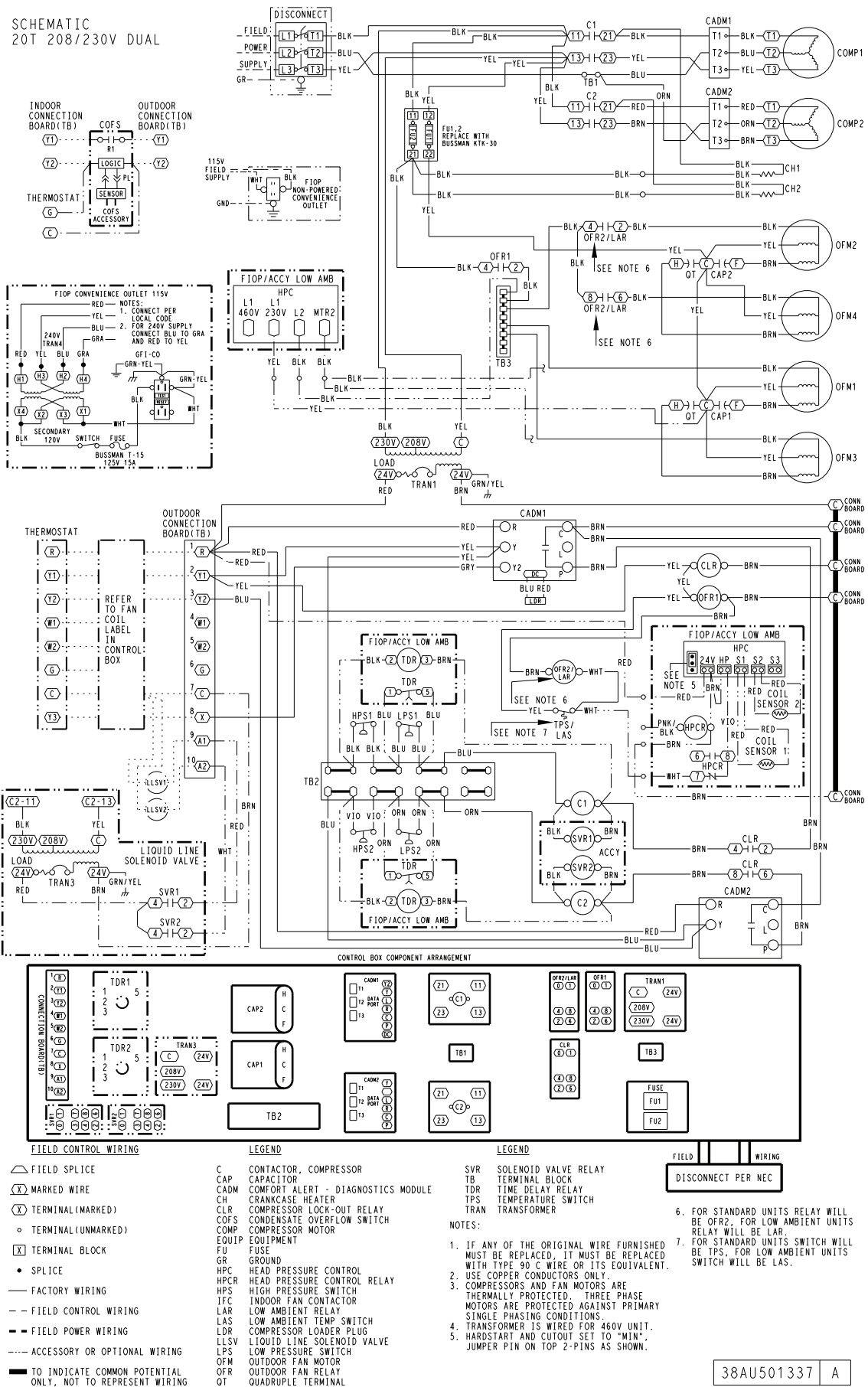

Fig. D — Dual Circuit/Three Stage Wiring Diagram, 20 Ton — 208/230-3-60 Unit



# APPENDIX B — WIRING DIAGRAMS (CONT)

SCHEMATIC  
20T 460V DUAL

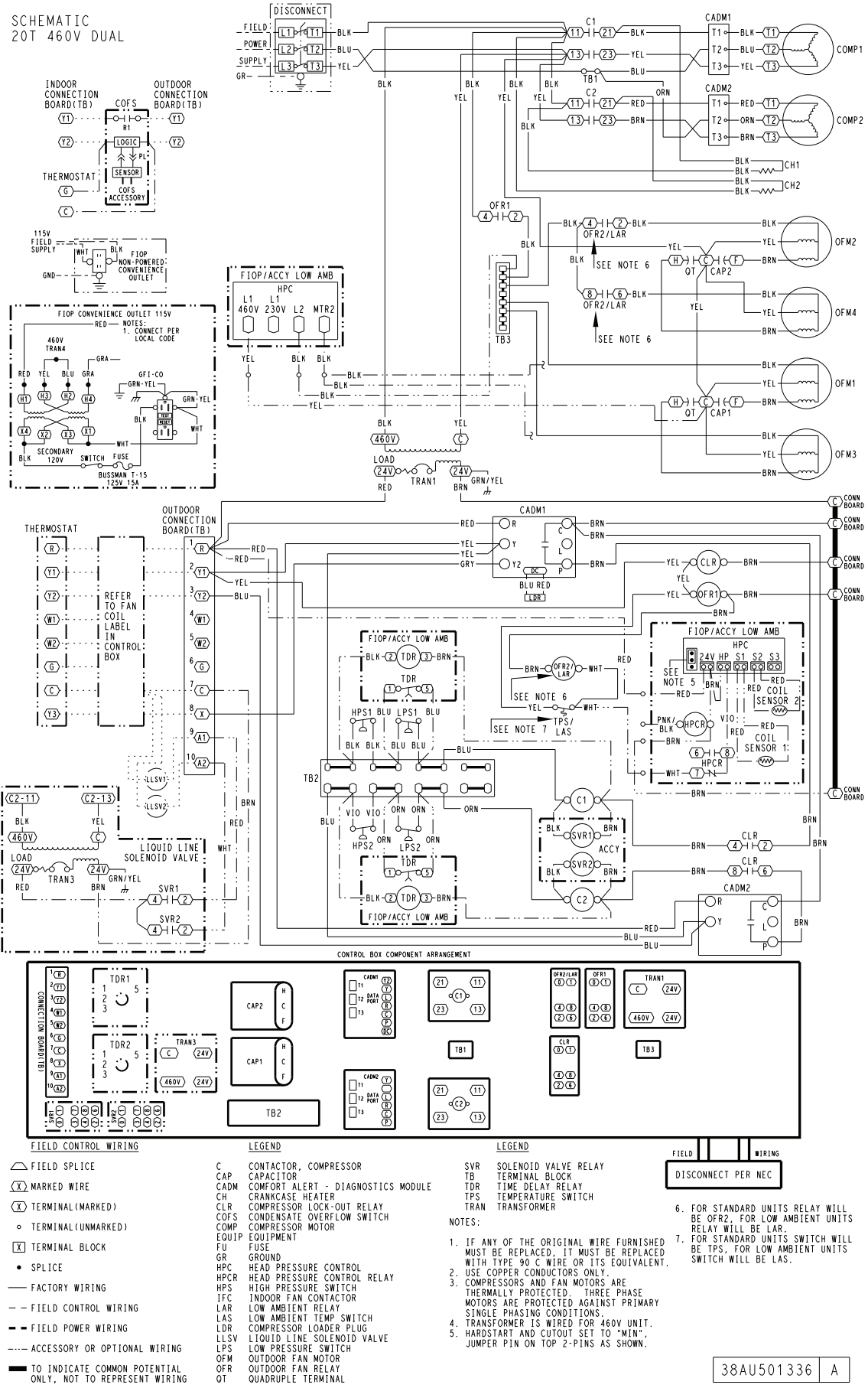

Fig. E — Dual Circuit/Three Stage Wiring Diagram, 20 Ton — 460-3-60 Unit

# APPENDIX B — WIRING DIAGRAMS (CONT)

SCHEMATIC  
20T 575V DUAL

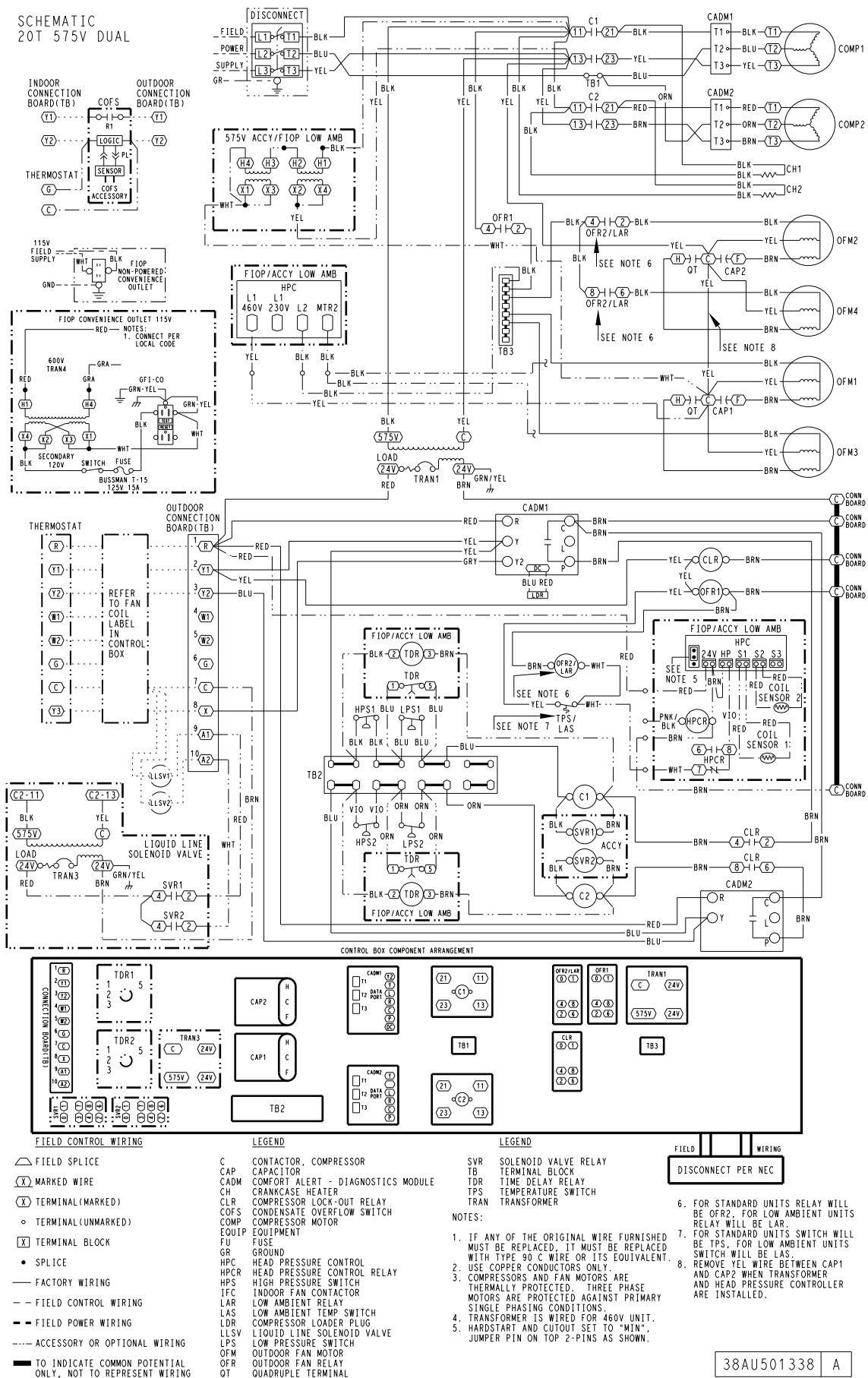
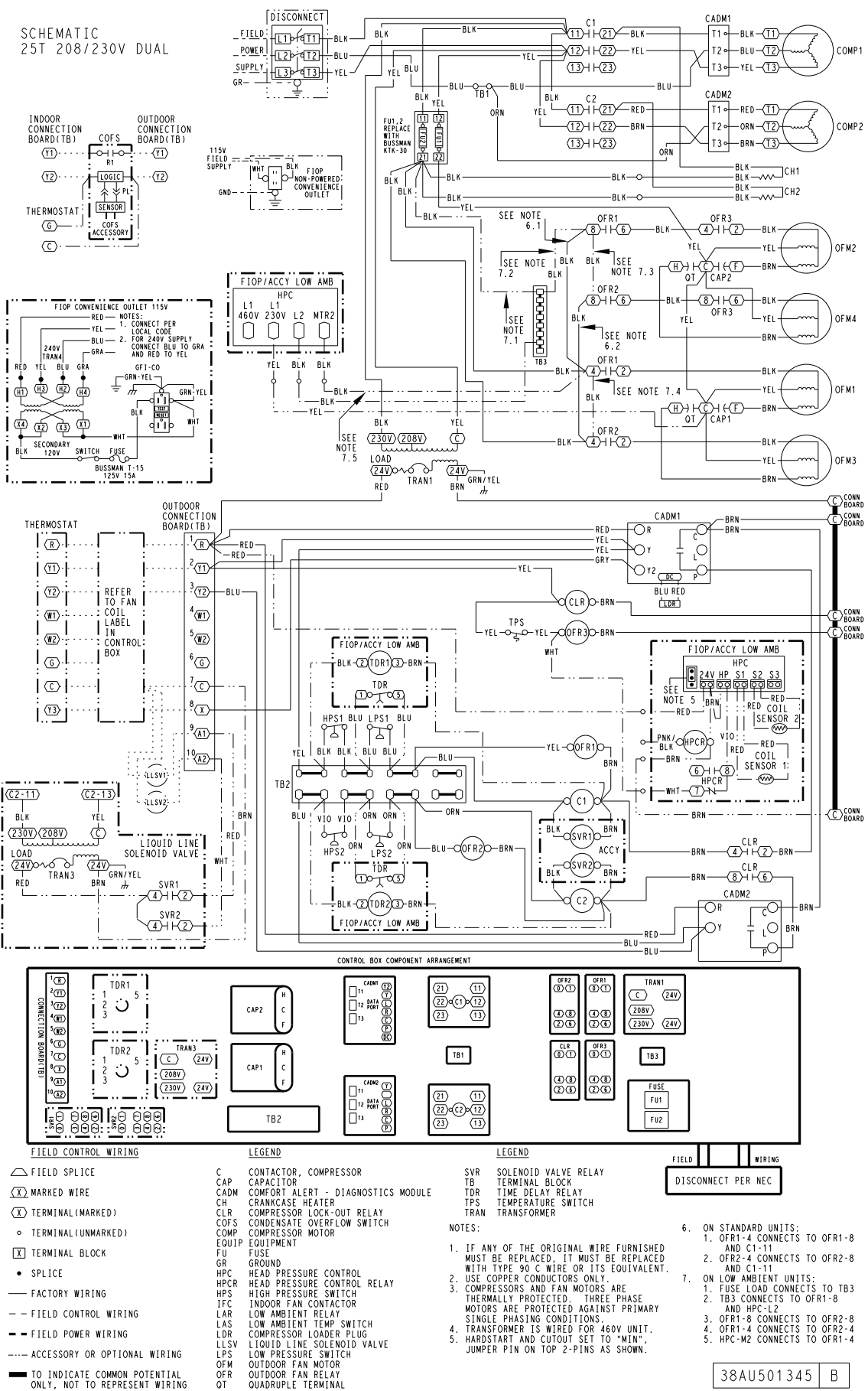

Fig. F — Dual Circuit/Three Stage Wiring Diagram, 20 Ton — 575-3-60 Unit

# APPENDIX B — WIRING DIAGRAMS (CONT)



**Fig. G — Dual Circuit/Three Stage Wiring Diagram, 25 Ton — 208/230-3-60 Unit**

# APPENDIX B — WIRING DIAGRAMS (CONT)

SCHEMATIC  
25T 460V DUAL

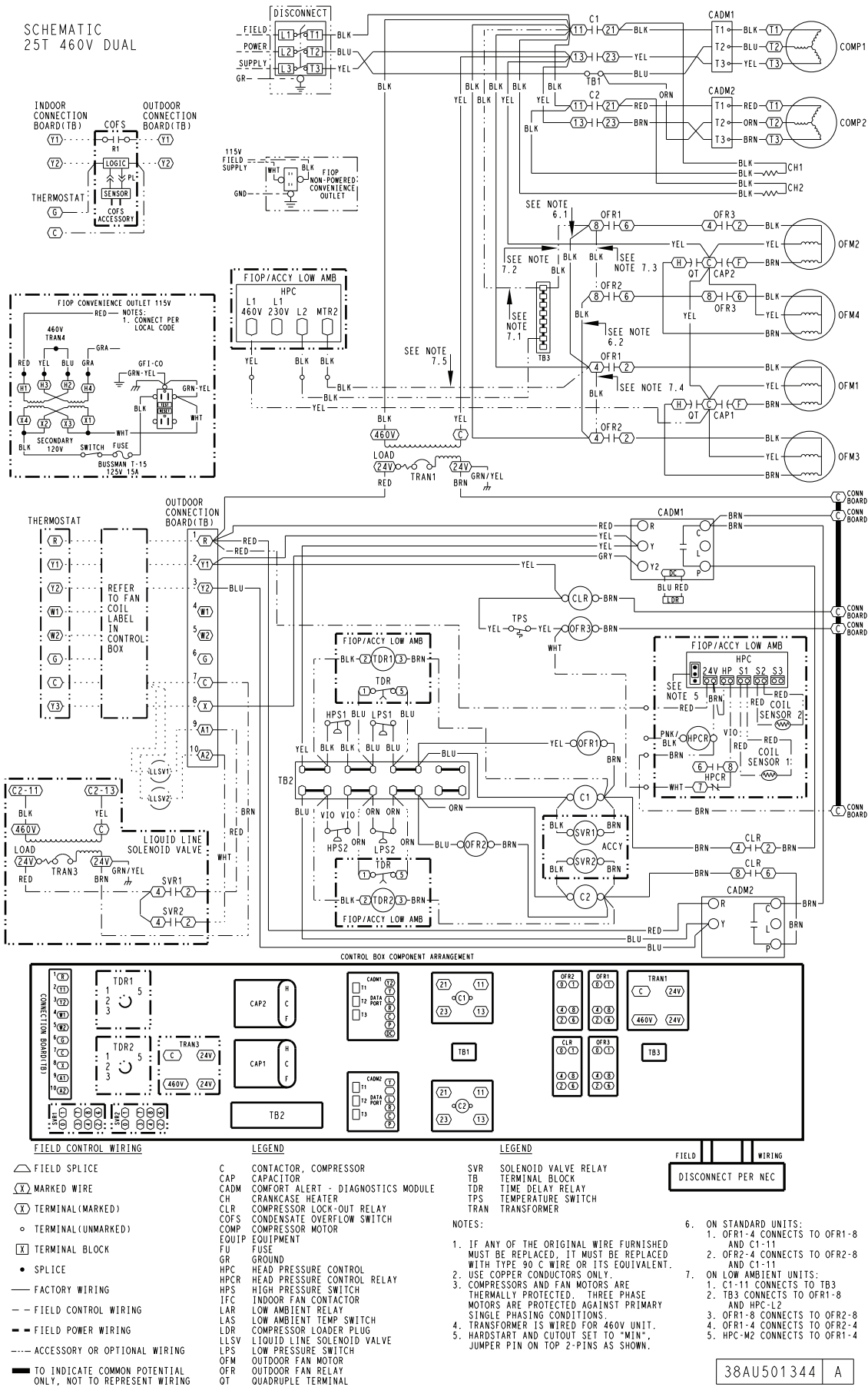

38AU501344 A

Fig. H — Dual Circuit/Three Stage Wiring Diagram, 25 Ton — 460-3-60 Unit

# APPENDIX B — WIRING DIAGRAMS (CONT)

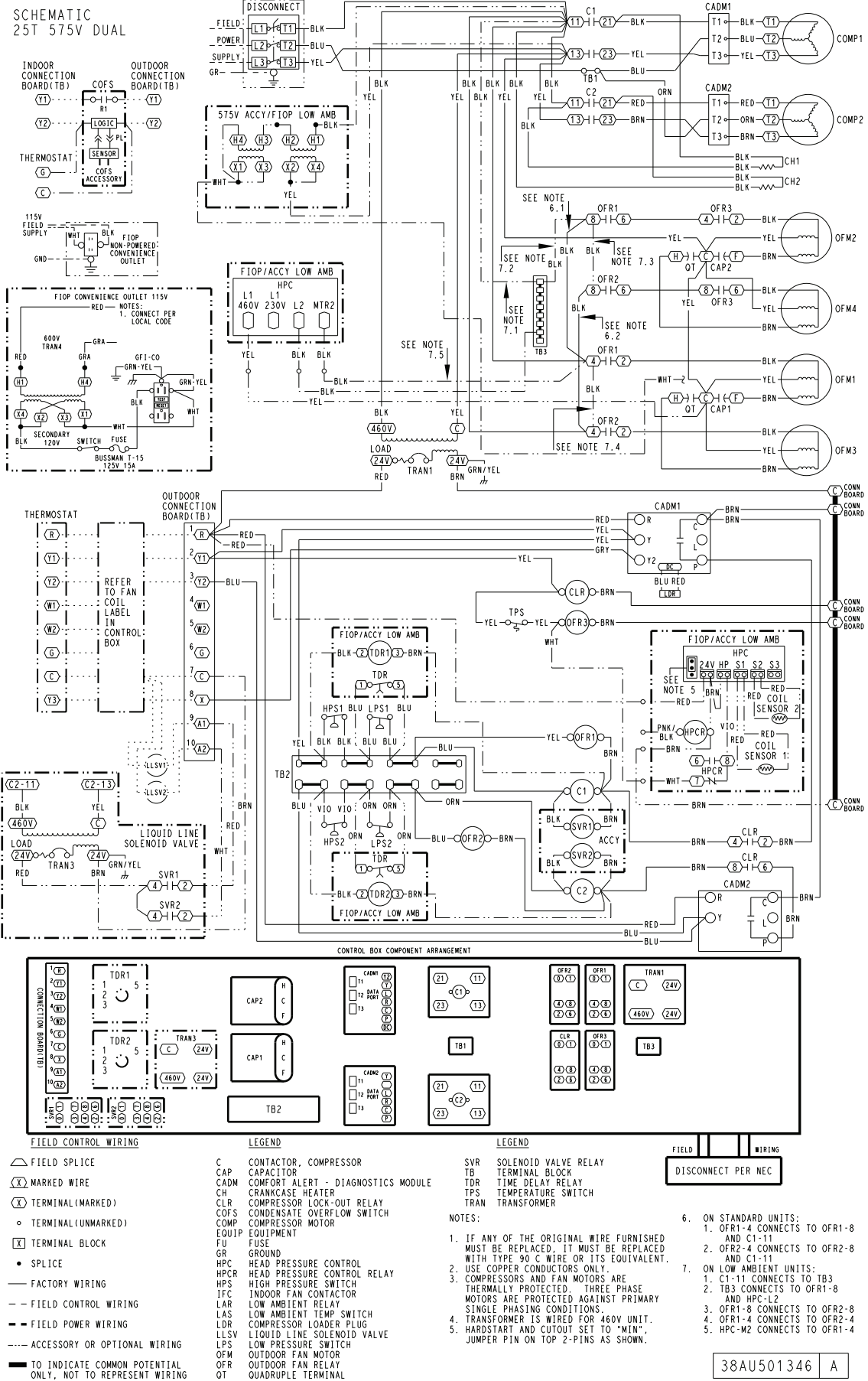
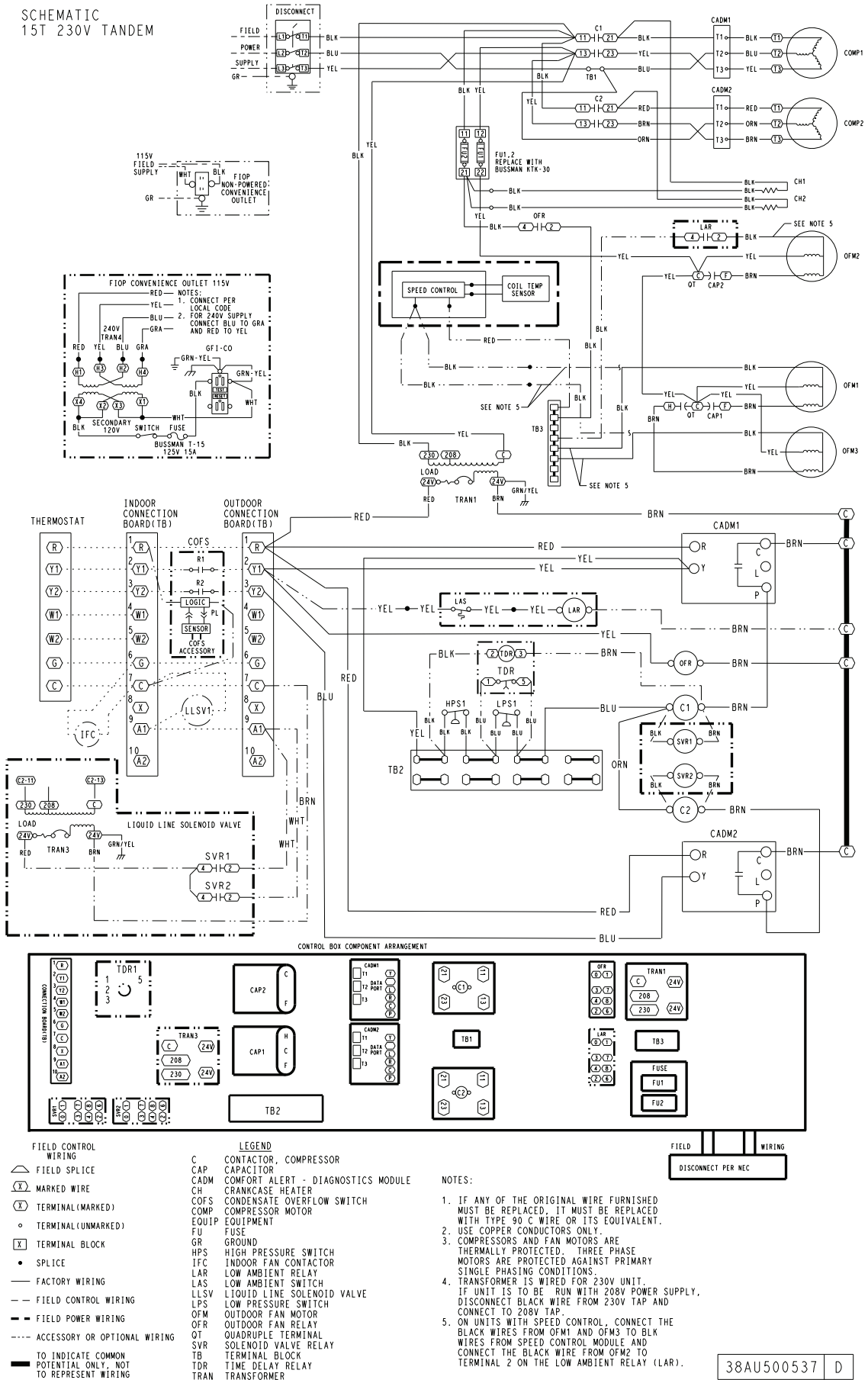

Fig. I — Dual Circuit/Three Stage Wiring Diagram, 25 Ton — 575-3-60 Unit

# APPENDIX B — WIRING DIAGRAMS (CONT)

SCHEMATIC  
15T 230V TANDEM



- FIELD CONTROL WIRING**
- △ FIELD SPLICE
  - (X) MARKED WIRE
  - (X) TERMINAL (MARKED)
  - TERMINAL (UNMARKED)
  - (X) TERMINAL BLOCK
  - SPLICE
  - FACTORY WIRING
  - - - FIELD CONTROL WIRING
  - - - FIELD POWER WIRING
  - - - ACCESSORY OR OPTIONAL WIRING
  - TO INDICATE COMMON POTENTIAL ONLY; NOT TO REPRESENT WIRING

- LEGEND**
- CAP CAPACITOR, COMPRESSOR
  - CADM1 COMFORT ALERT - DIAGNOSTICS MODULE
  - CHM CRANKCASE HEATER
  - COFS CONDENSATE OVERFLOW SWITCH
  - COMP COMPRESSOR MOTOR
  - EQUIP EQUIPMENT
  - FU FUSE
  - GRND GROUND
  - HPS HIGH PRESSURE SWITCH
  - IFC INDOOR FAN CONTACTOR
  - LAR LOW AMBIENT RELAY
  - LAS LOW AMBIENT SWITCH
  - LLSV LIQUID LINE SOLENOID VALVE
  - LPS LOW PRESSURE SWITCH
  - OFM OUTDOOR FAN MOTOR
  - OFR OUTDOOR FAN RELAY
  - QT QUADRUPLE TERMINAL
  - SVR SOLENOID VALVE RELAY
  - TB TERMINAL BLOCK
  - TDR TIME DELAY RELAY
  - TRAN TRANSFORMER

- NOTES:**
1. IF ANY OF THE ORIGINAL WIRE FURNISHED MUST BE REPLACED, IT MUST BE REPLACED WITH TYPE 90 C WIRE OR ITS EQUIVALENT.
  2. USE COPPER CONDUCTORS ONLY.
  3. COMPRESSORS AND FAN MOTORS ARE THERMALLY PROTECTED. THREE PHASE MOTORS ARE PROTECTED AGAINST PRIMARY SINGLE PHASING CONDITIONS.
  4. TRANSFORMER IS WIRED FOR 230V UNIT. IF UNIT IS TO BE RUN WITH 208V POWER SUPPLY, DISCONNECT BLACK WIRE FROM 230V TAP AND CONNECT TO 208V TAP.
  5. ON UNITS WITH SPEED CONTROL, CONNECT THE BLACK WIRES FROM OFM1 AND OFM3 TO BLK WIRE FROM SPEED CONTROL MODULE AND CONNECT THE BLACK WIRE FROM OFM2 TO TERMINAL 2 ON THE LOW AMBIENT RELAY (LAR).

38AU500537 D

Fig. J — Single Circuit/Two Stage Wiring Diagram, 15 Ton — 208/230-3-60 Unit



# APPENDIX B — WIRING DIAGRAMS (CONT)

SCHEMATIC  
15T 460V TANDEM

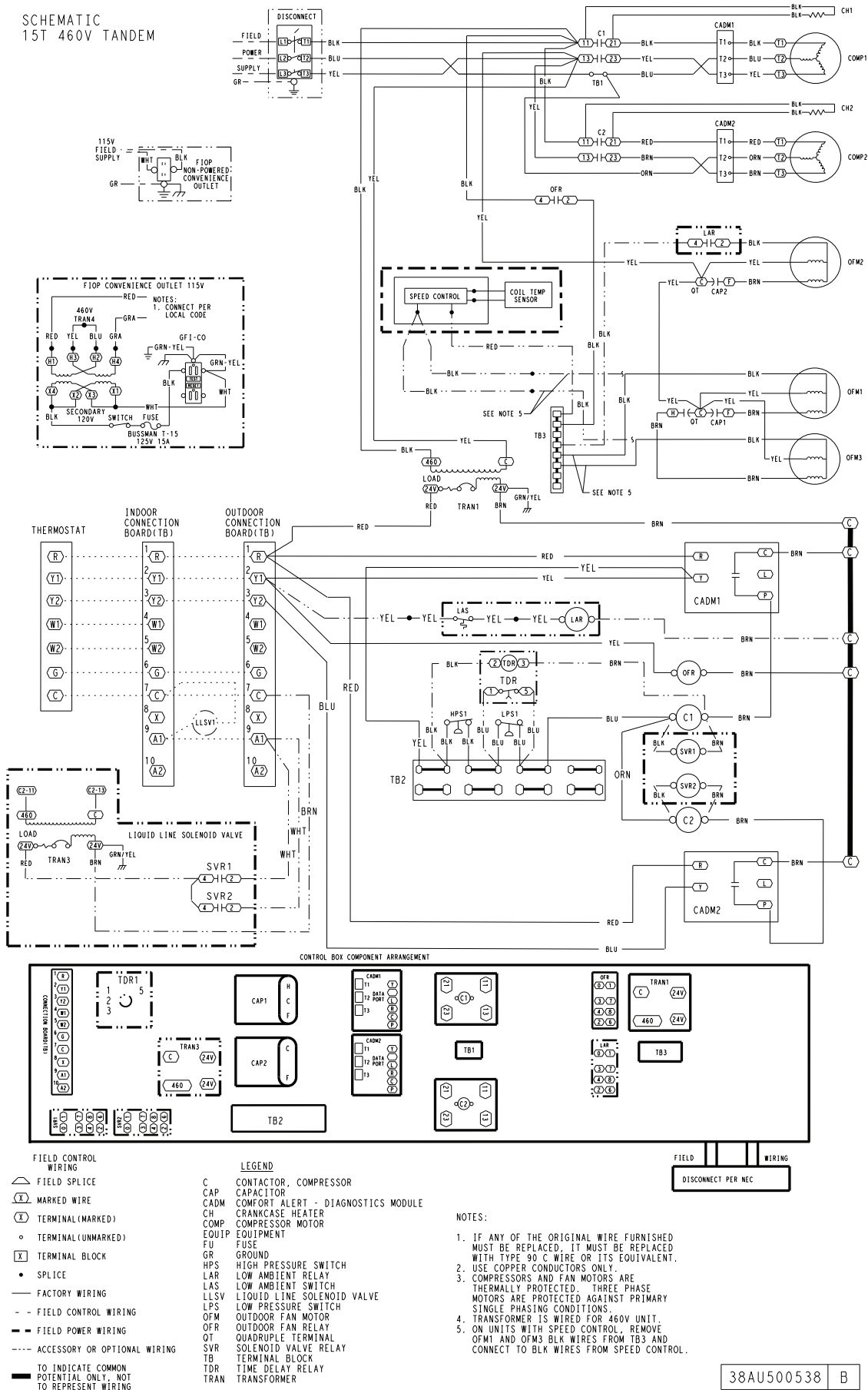
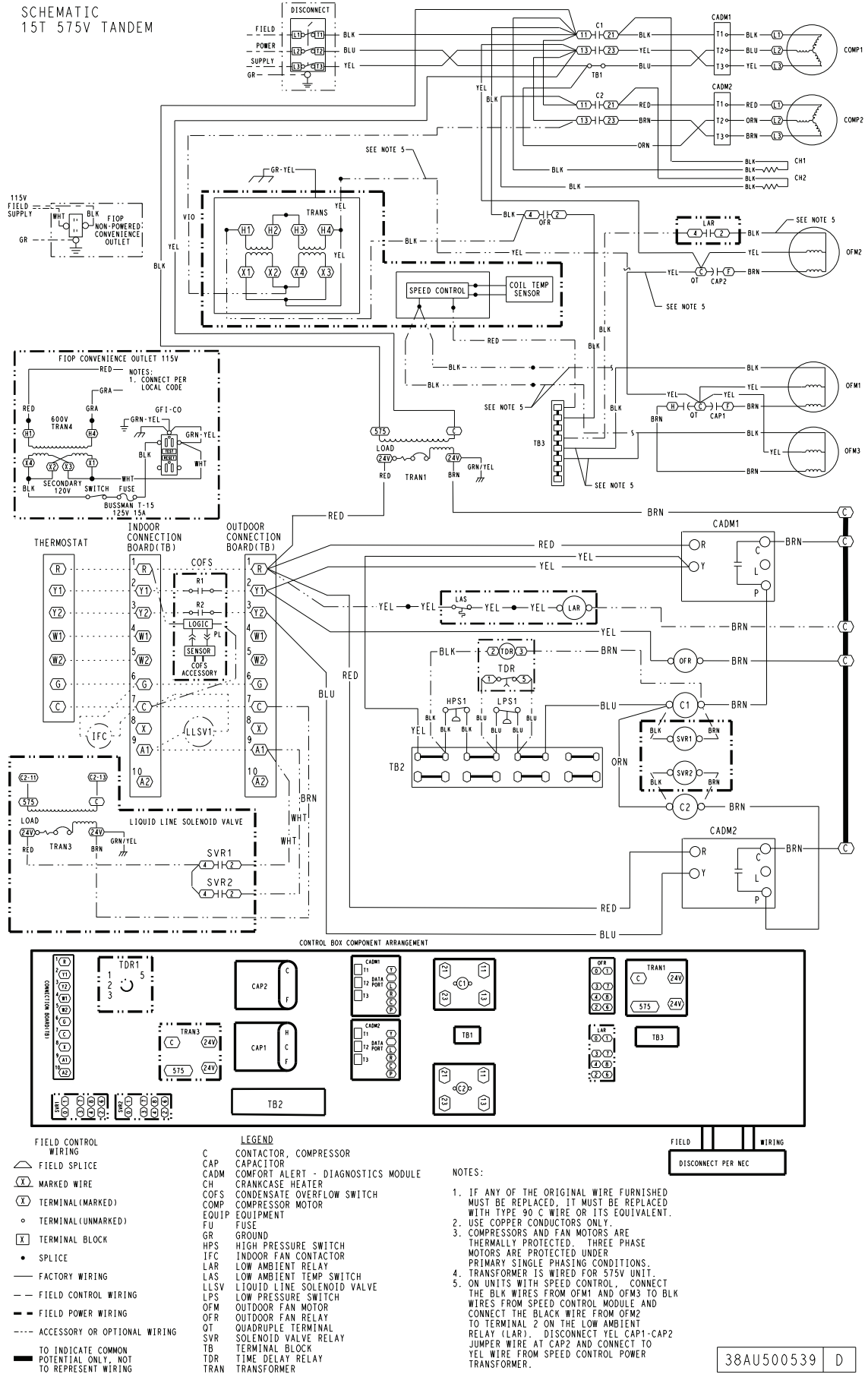

Fig. K — Single Circuit/Two Stage Wiring Diagram, 15 Ton — 460-3-60 Unit



# APPENDIX B — WIRING DIAGRAMS (CONT)



**Fig. L — Single Circuit/Two Stage Wiring Diagram, 15 Ton — 575-3-60 Unit**

# APPENDIX B — WIRING DIAGRAMS (CONT)

SCHEMATIC  
20T 230V TANDEM

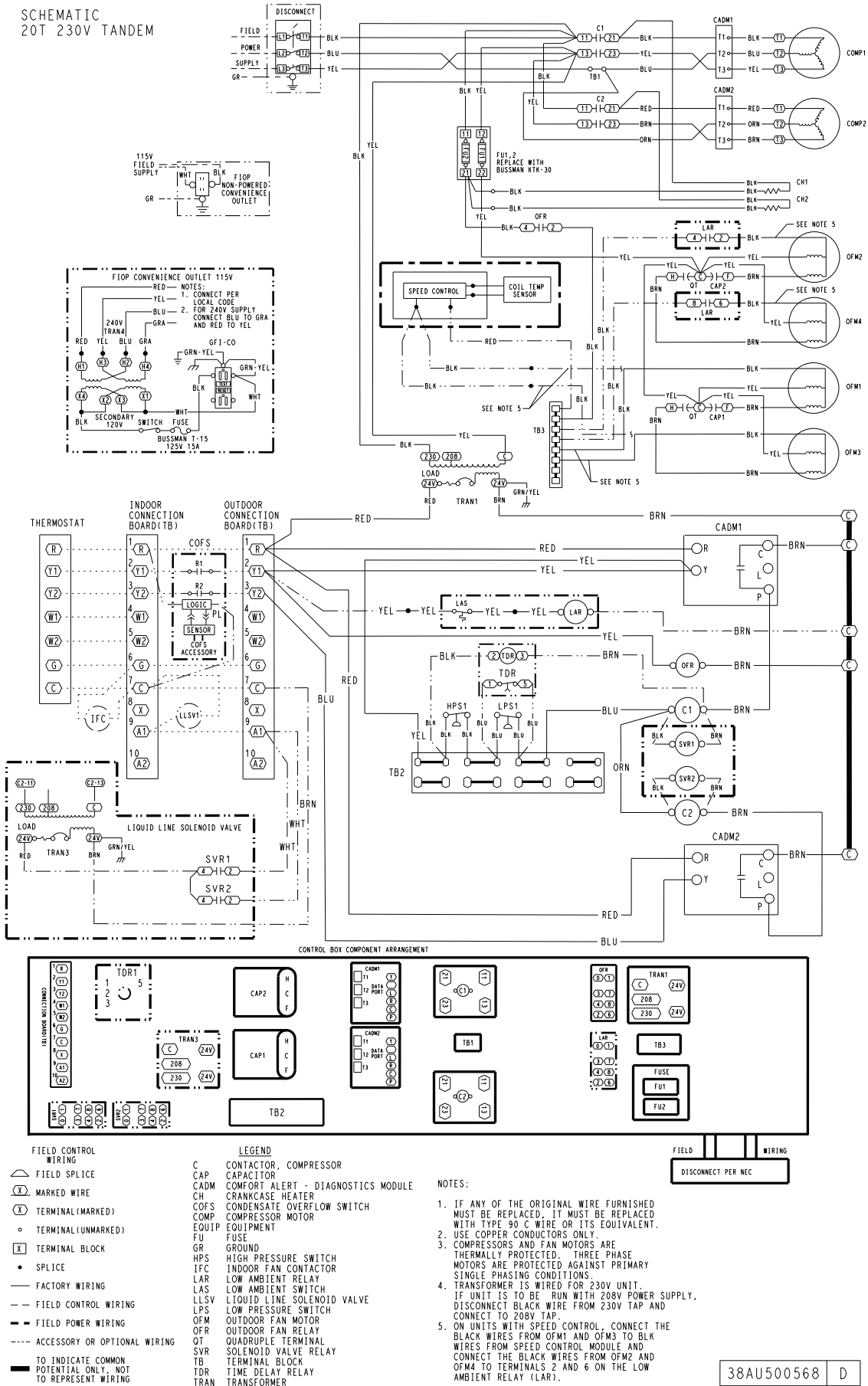

Fig. M — Single Circuit/Two Stage Wiring Diagram, 20 Ton — 208/230-3-60 Unit

# APPENDIX B — WIRING DIAGRAMS (CONT)

SCHEMATIC  
20T 460V TANDEM

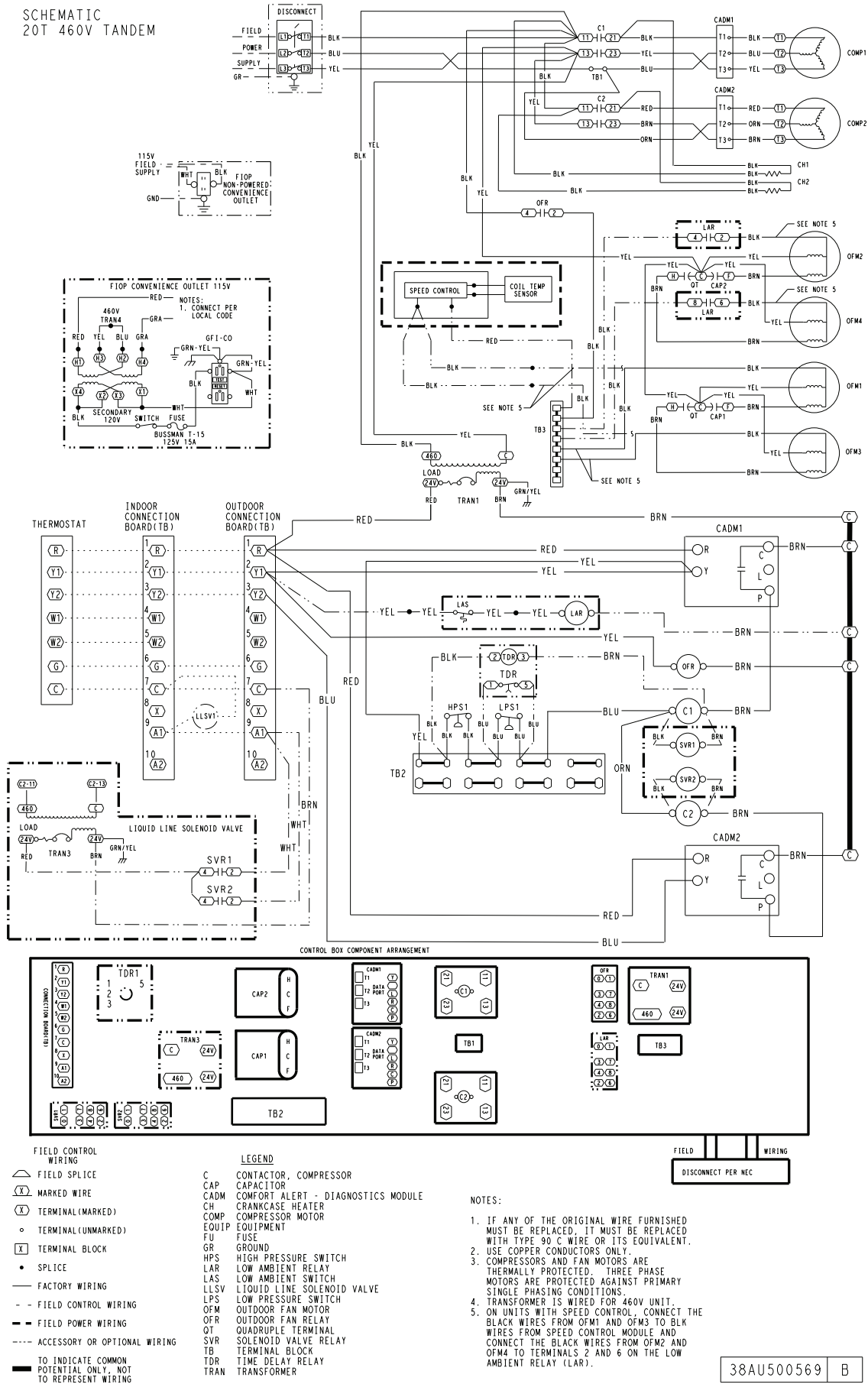
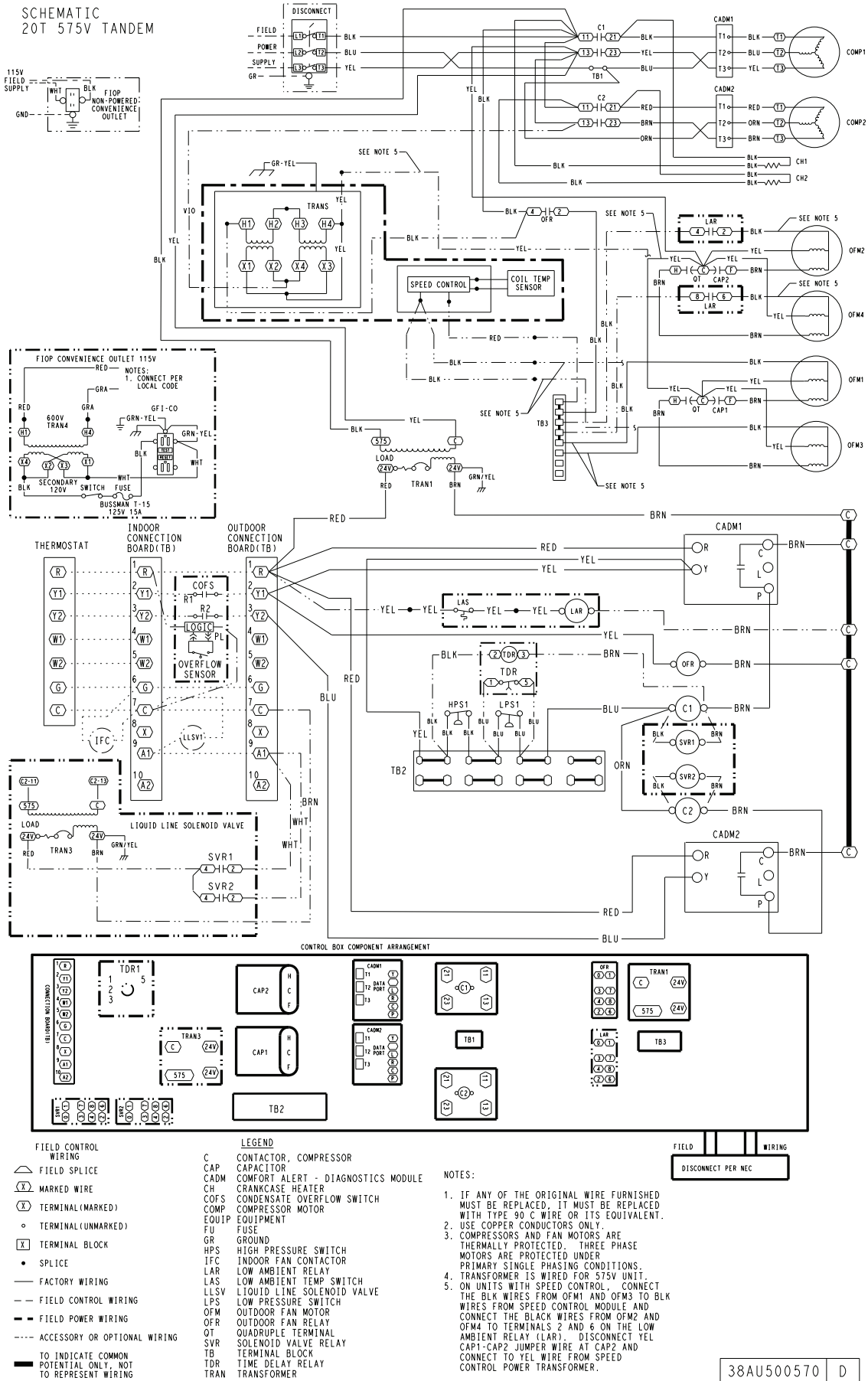

Fig. N — Single Circuit/Two Stage Wiring Diagram, 20 Ton — 460-3-60 Unit

# APPENDIX B — WIRING DIAGRAMS (CONT)



**Fig. O — Single Circuit/Two Stage Wiring Diagram, 20 Ton — 575-3-60 Unit**

## APPENDIX C — LOW AMBIENT OPTION

Units with the factory installed low ambient option are equipped with a solid-state head pressure control which regulates fan speed. A temperature sensor, mounted on either circuit 1 (38AUZ units) or both circuits 1 and 2 (38AUD units) of the outdoor coil controls the speed of approved outdoor fan motors in order to maintain a constant head pressure in the outdoor coil (see Fig. P-R). The control maintains the appropriate head pressure at low ambient temperatures down to  $-20^{\circ}\text{F}$  ( $-28^{\circ}\text{C}$ ).

Wind baffles are required to prevent wind cross currents from causing abnormally low condensing temperatures.

**IMPORTANT:** Wind baffles are field-fabricated; they are not included with the factory-installed Motormaster control option.

Use 20-gauge sheet metal to fabricate wind baffles (see Fig. S and Table A). See Fig. T-V for finished installation.

### OPERATION

Fan on/off control in cooling-only units (38AUZ, 38AUD) is provided by an outdoor fan relay (OFR) or two outdoor fan relays (OFR1 and OFR2) for 38AUD 28. In cooling mode, fan motor speed of outdoor motors OFM1 and OFM3 is regulated by the speed control temperature sensor on outdoor coil 1 for a minimum coil condensing temperature of approximately  $100^{\circ}\text{F}$  ( $38^{\circ}\text{C}$ ) at higher outdoor ambient temperature and  $80^{\circ}\text{F}$  ( $27^{\circ}\text{C}$ ) at lower ambient. Additionally, outdoor fan motor OFM2 and OFM4 are turned on/off by the low ambient temperature switch (LAS), operating the low ambient relay (LAR). The LAS control temperatures are open  $55^{\circ}\text{F} \pm 2.16^{\circ}\text{F}$ , close  $60^{\circ}\text{F} \pm 2.16^{\circ}\text{F}$  (open  $12.8^{\circ}\text{C} \pm 1.2^{\circ}\text{C}$ , close  $15.6^{\circ}\text{C} \pm 1.2^{\circ}\text{C}$ ).

To override the speed control for full fan speed operation during service or maintenance, either:

- a. remove sensor and place in hot water  $>120^{\circ}\text{F}$  ( $>49^{\circ}\text{C}$ ).
- or
- b. rewire to bypass control by connecting speed control input and output power wires.

### Troubleshooting

OBSERVATION	POSSIBLE REMEDY
Fans won't start.	All fans: Check power and wiring Check outdoor fan relay (OFR) OFM1, OFM3 only: Check speed control sensor location Check speed sensor resistance OFM2, OFM4 only: Check low ambient switch (LAS) Check low ambient relay (LAR)
Cooling — Center outdoor fans (OFM2, OFM4) off below approximately $55^{\circ}\text{F}$ ( $16^{\circ}\text{C}$ ) outdoor ambient.	Normal operation
Cooling — Center outdoor fans (OFM2, OFM4) not on above approximately $60^{\circ}\text{F}$ ( $12.8^{\circ}\text{C}$ ) outdoor ambient.	Check low ambient switch (LAS) Check low ambient relay (LAR)
Cooling — Slow fan speed for outer fans (OFM1, OFM3) at start or during low outdoor ambient	Normal operation
Cooling — Slow fan speed for outer fans (OFM1, OFM3) above $85^{\circ}\text{F}$ ( $29^{\circ}\text{F}$ ) outdoor ambient (should be full speed)	Check speed control sensor location Check speed control sensor resistance Check fan motor capacitor
Cooling — motor current into speed control is greater than motor nameplate FLA	Normal operation Up to 30% higher A at partial speed at low ambient

### Speed Control Sensor Resistance

TEMPERATURE		RESISTANCE
$^{\circ}\text{F} \pm -2^{\circ}\text{F}$	$^{\circ}\text{C} \pm -1^{\circ}\text{C}$	Ohms, nominal
-22	-30	88,350
-4	-20	48,485
14	-10	27,650
32	0	16,325
50	12	9,950
68	20	6,245
77	25	5,000
86	30	4,028
104	40	2,663
122	50	1,801
140	60	1,244
158	70	876

## APPENDIX C — LOW AMBIENT OPTION (CONT)

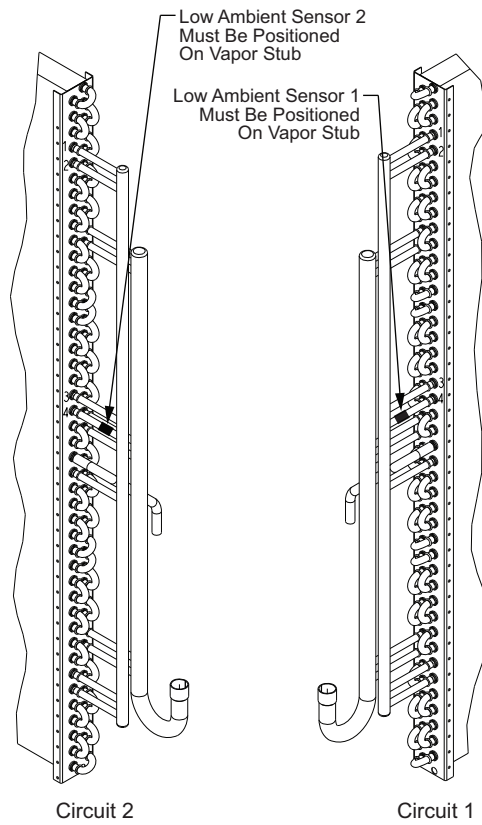

**Fig. P — 38AUD\*16 Low Ambient Sensor Locations**

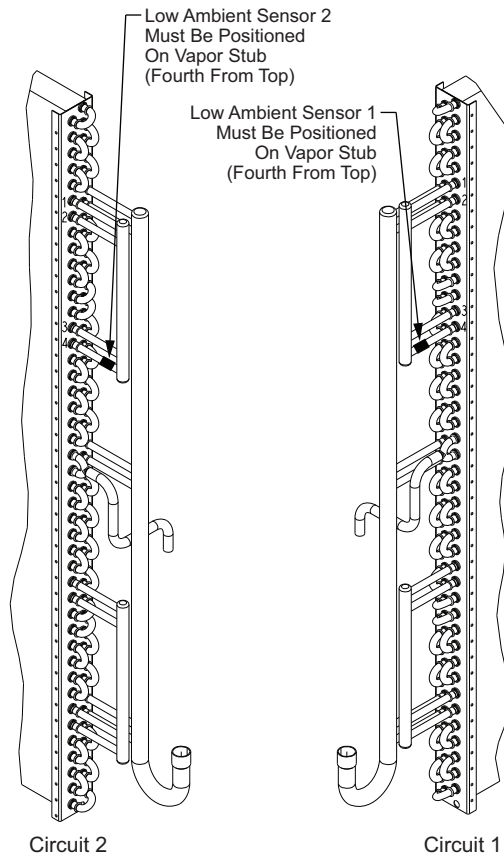

**Fig. Q — 38AUD825/28 Low Ambient Sensor Locations**

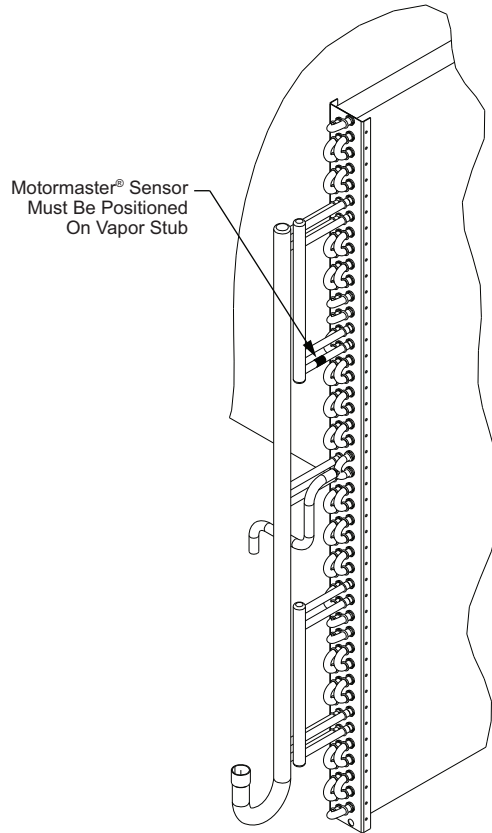

**Fig. R — 38AUZ\*16/25 Low Ambient Sensor Location**

**Table A — Wind Baffle Dimension**

DIMENSIONS (in.)										
UNIT	BAFFLE	A	B	C	D	E	F	G	H	J
<b>38AUZ*16 38AUD*16</b>	LEFT SIDE	10-3/4	11-1/2	12-1/4	43-1/8	4-1/4	13-1/4	22-1/4	31-1/4	40-1/4
	BACK	80-1/4	81	81-3/4	43-1/8	8-3/8	18	27-1/4	40	—
	RIGHT SIDE	38-3/4	39-1/2	40-1/4	43-1/8	8-3/8	18	27-1/4	40	—
	FRONT	27	27-3/4	28-1/2	43-1/8	8-3/8	18	27-1/4	40	—
<b>38AUZ*25 38AUD*25 38AUD*28</b>	LEFT SIDE	32-7/8	33-5/8	34-3/8	43-1/8	4-1/4	13-1/4	22-1/4	31-1/4	40-1/4
	BACK	47-3/4	48-1/2	49-1/4	43-1/8	4-1/4	13-1/4	22-1/4	31-1/4	40-1/4
	RIGHT SIDE	61-1/8	61-7/8	62-5/8	43-1/8	3-3/4	12-3/4	21-3/4	30-3/4	39-3/4
	FRONT	20-1/8	20-7/8	21-5/8	43-1/8	3-1/4	12-3/4	21-3/4	30-3/4	39-3/4
DIMENSIONS (mm)										
UNIT	BAFFLE	A	B	C	D	E	F	G	H	J
<b>38AUZ*16 38AUD*16</b>	LEFT SIDE	272	291	310	1095	108	337	656	794	1022
	BACK	2037	2056	2075	1095	212	457	694	1015	—
	RIGHT SIDE	983	1002	1021	1095	212	457	694	1015	—
	FRONT	684	704	723	1095	95	324	552	781	1010
<b>38AUZ*25 38AUD*25 38AUD*28</b>	LEFT SIDE	834	853	872	1095	108	337	656	794	1022
	BACK	1214	1233	1252	1095	108	337	565	794	1022
	RIGHT SIDE	1551	1570	1589	1095	95	324	552	781	1010
	FRONT	510	530	549	1095	95	324	552	781	1010



# APPENDIX C — LOW AMBIENT OPTION (CONT)

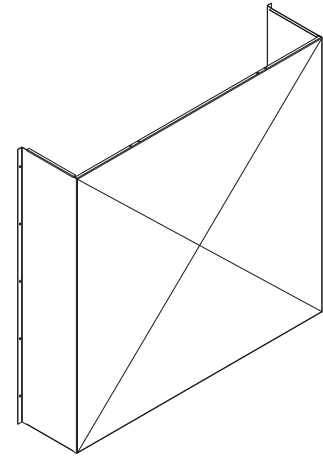
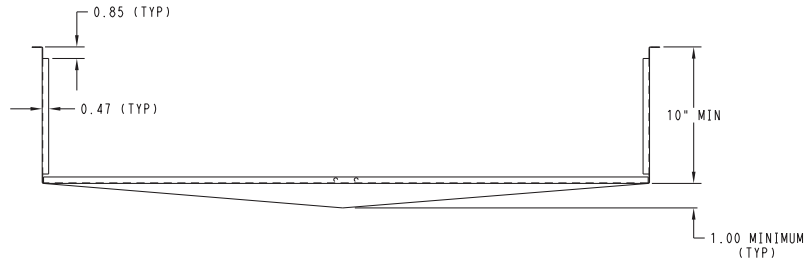

58

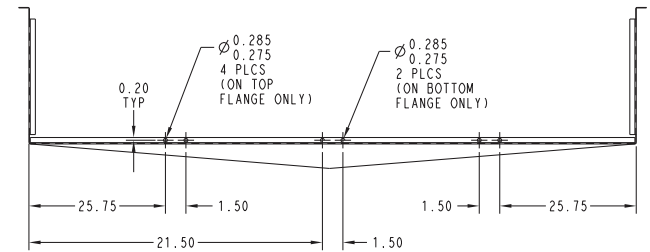
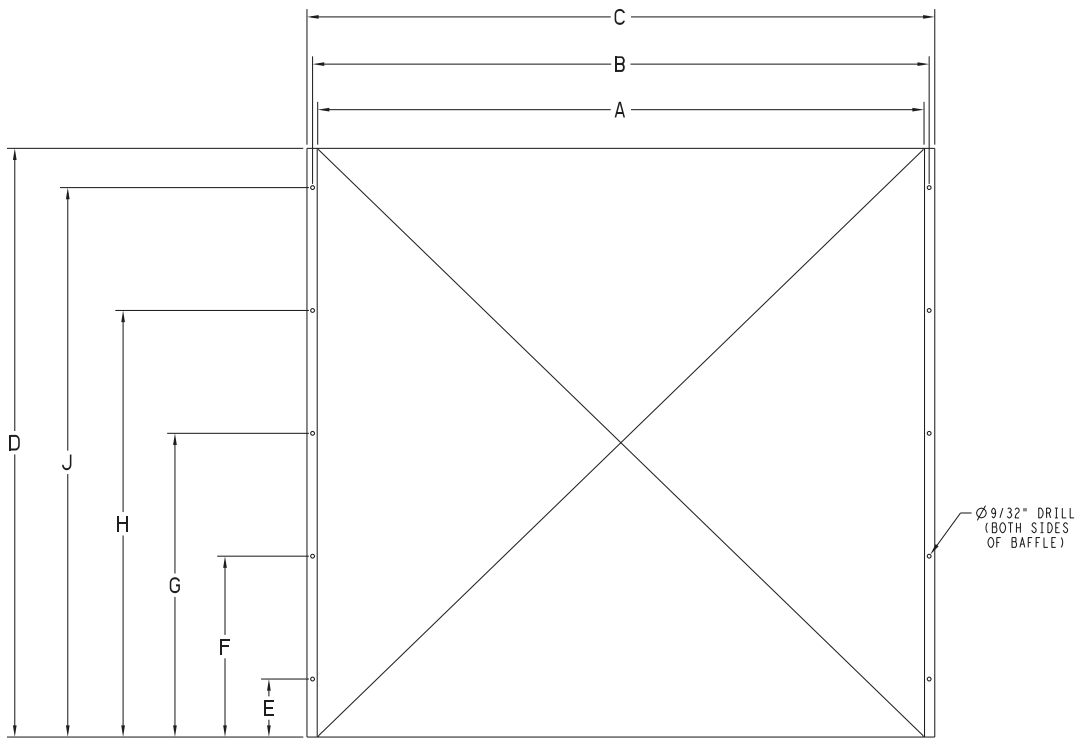

FOR 15 TON A/C AND HP  
BACK SIDE ONLY

Fig. S — Wind Baffles – Fabrication

APPENDIX C — LOW AMBIENT OPTION (CONT)

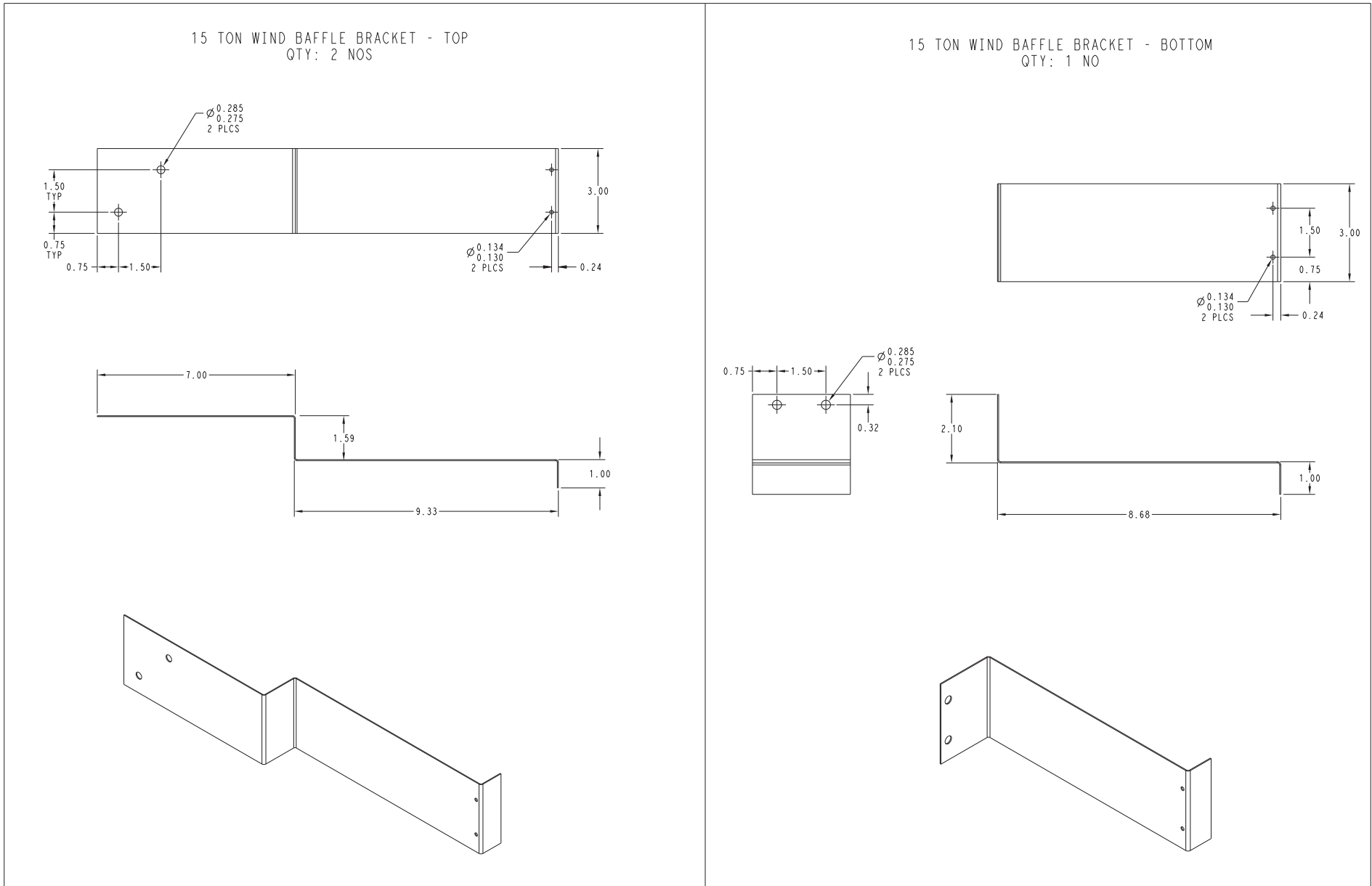

59

Fig. T — 15 Ton Wind Baffle Brackets – Fabrication

APPENDIX C — LOW AMBIENT OPTION (CONT)

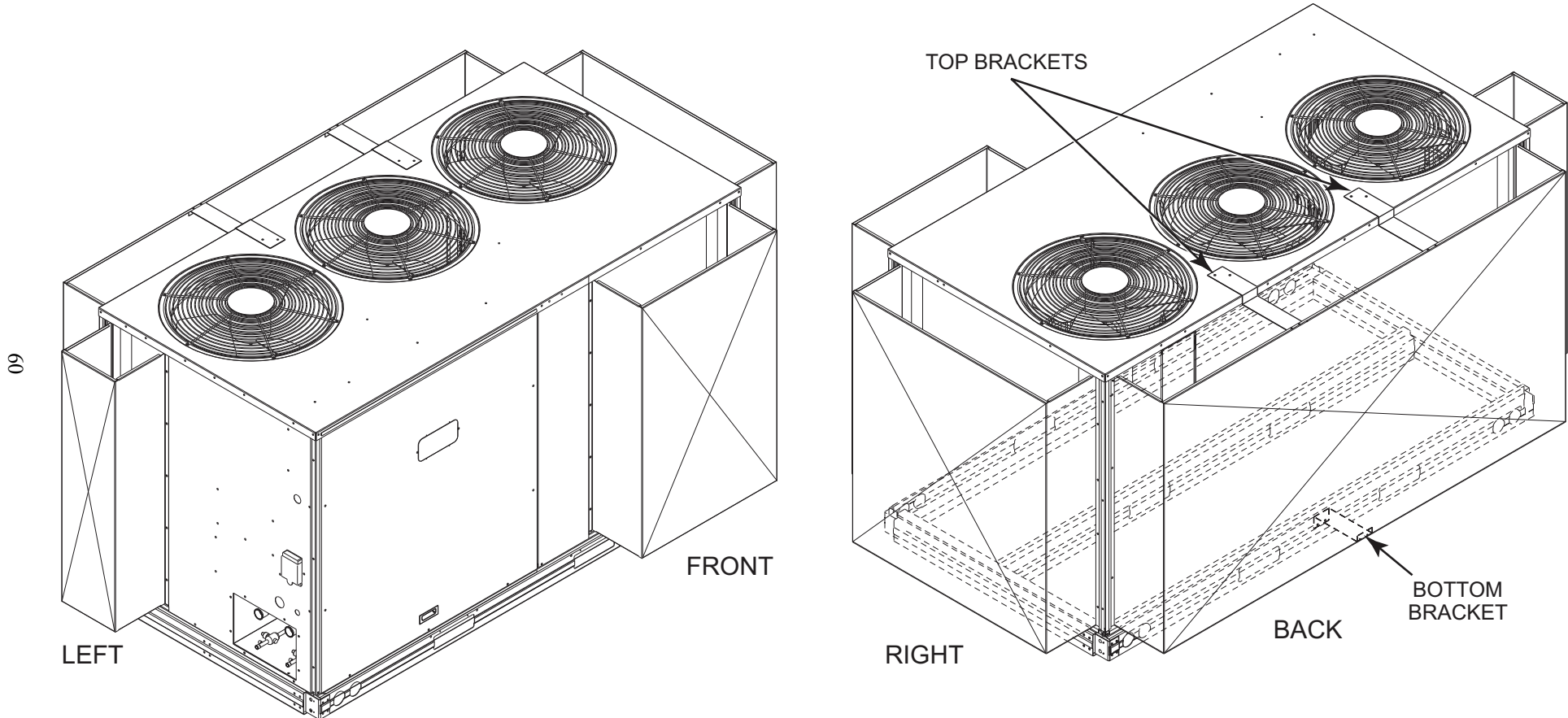
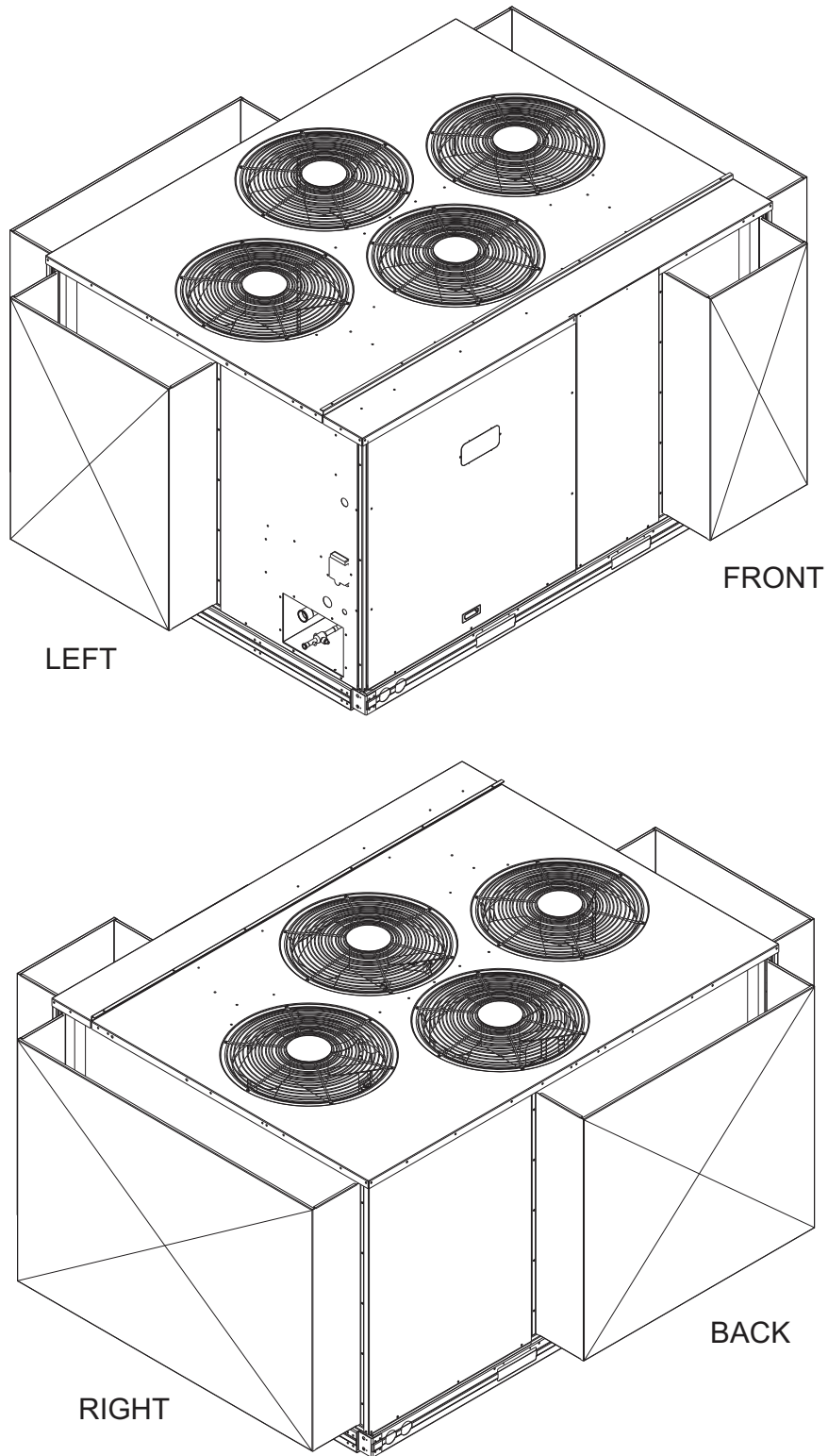

Fig. U — Wind Baffle Installation — 15 Ton Units

**APPENDIX C — LOW AMBIENT OPTION (CONT)**



**Fig. V — Wind Baffle Installation – 20 and 25 Ton Units**



**START-UP CHECKLIST**  
(Remove and use for Job File)

**NOTE: To avoid injury to personnel and damage to equipment or property when completing the procedures listed in this start-up checklist, use good judgment, follow safe practices, and adhere to the safety considerations/information as outlined in preceding sections of this Installation, Start-Up, and Service document.**

**I. PRELIMINARY INFORMATION**

OUTDOOR: MODEL NO. \_\_\_\_\_ SERIAL NO. \_\_\_\_\_  
INDOOR: AIR HANDLER MANUFACTURER \_\_\_\_\_  
MODEL NO. \_\_\_\_\_ SERIAL NO. \_\_\_\_\_  
ADDITIONAL ACCESSORIES \_\_\_\_\_

**II. PRE-START-UP**

OUTDOOR UNIT  
IS THERE ANY SHIPPING DAMAGE? (Y/N) \_\_\_\_\_  
IF SO, WHERE: \_\_\_\_\_  
\_\_\_\_\_  
WILL THIS DAMAGE PREVENT UNIT START-UP? (Y/N) \_\_\_\_\_  
CHECK POWER SUPPLY. DOES IT AGREE WITH UNIT? (Y/N) \_\_\_\_\_  
HAS THE GROUND WIRE BEEN CONNECTED? (Y/N) \_\_\_\_\_  
VERIFY GROUND INTEGRITY WITH CONTINUITY TEST? (Y/N) \_\_\_\_\_  
HAS THE CIRCUIT PROTECTION BEEN SIZED AND INSTALLED PROPERLY? (Y/N) \_\_\_\_\_  
ARE THE POWER WIRES TO THE UNIT SIZED AND INSTALLED PROPERLY? (Y/N) \_\_\_\_\_

**CONTROLS**

ARE THERMOSTAT AND INDOOR FAN CONTROL WIRING CONNECTIONS MADE AND CHECKED? (Y/N) \_\_\_\_\_  
(Thermostat wiring must be made directly to the fan coil unit)  
ARE ALL WIRING TERMINALS (including main power supply) TIGHT? (Y/N) \_\_\_\_\_  
HAS CRANKCASE HEATER BEEN ENERGIZED FOR 24 HOURS? (Y/N) \_\_\_\_\_

**INDOOR UNIT**

HAS WATER BEEN PLACED IN DRAIN PAN TO CONFIRM PROPER DRAINAGE? (Y/N) \_\_\_\_\_  
ARE PROPER AIR FILTERS IN PLACE? (Y/N) \_\_\_\_\_  
HAVE FAN AND MOTOR PULLEYS BEEN CHECKED FOR PROPER ALIGNMENT? (Y/N) \_\_\_\_\_  
DO THE FAN BELTS HAVE PROPER TENSION? (Y/N) \_\_\_\_\_  
HAS CORRECT FAN ROTATION BEEN CONFIRMED? (Y/N) \_\_\_\_\_

**PIPING**

ARE LIQUID LINE SOLENOID VALVES LOCATED AT THE INDOOR COILS AS REQUIRED? (Y/N) \_\_\_\_\_  
HAVE LEAK CHECKS BEEN MADE AT COMPRESSOR, OUTDOOR AND INDOOR COILS, TXVs  
(Thermostatic Expansion Valves), SOLENOID VALVES, FILTER DRIERS, AND FUSIBLE PLUGS WITH  
A LEAK DETECTOR? (Y/N) \_\_\_\_\_  
LOCATE, REPAIR, AND REPORT ANY LEAKS.  
HAVE LIQUID LINE SERVICE VALVES BEEN OPENED? (Y/N) \_\_\_\_\_  
HAVE SUCTION LINE SERVICE VALVES BEEN OPENED? (Y/N) \_\_\_\_\_

**CHECK VOLTAGE IMBALANCE**

LINE-TO-LINE VOLTS: AB \_\_\_\_\_ V AC \_\_\_\_\_ V BC \_\_\_\_\_ V

$(AB + AC + BC) / 3 = \text{AVERAGE VOLTAGE} = \text{_____ V}$

MAXIMUM DEVIATION FROM AVERAGE VOLTAGE = \_\_\_\_\_ V

VOLTAGE IMBALANCE =  $100 \times (\text{MAX DEVIATION}) / (\text{AVERAGE VOLTAGE}) = \text{_____}$

IF OVER 2% VOLTAGE IMBALANCE, DO NOT ATTEMPT TO START SYSTEM!

CALL LOCAL POWER COMPANY FOR ASSISTANCE.

CHECK INDOOR UNIT FAN SPEED AND RECORD \_\_\_\_\_

CHECK OUTDOOR UNIT FAN SPEED AND RECORD \_\_\_\_\_

AFTER AT LEAST 10 MINUTES RUNNING TIME, RECORD THE FOLLOWING MEASUREMENTS:

SUCTION PRESSURE CIR 1: \_\_\_\_\_ CIR 2: \_\_\_\_\_

SUCTION LINE TEMP CIR 1: \_\_\_\_\_ CIR 2: \_\_\_\_\_

LIQUID PRESSURE CIR 1: \_\_\_\_\_ CIR 2: \_\_\_\_\_

LIQUID LINE TEMP CIR 1: \_\_\_\_\_ CIR 2: \_\_\_\_\_

ENTERING OUTDOOR UNIT AIR TEMP \_\_\_\_\_

LEAVING OUTDOOR UNIT AIR TEMP \_\_\_\_\_

INDOOR UNIT ENTERING-AIR DB (dry bulb) TEMP \_\_\_\_\_

INDOOR UNIT ENTERING-AIR WB (wet bulb) TEMP \_\_\_\_\_

INDOOR UNIT LEAVING-AIR DB TEMP \_\_\_\_\_

INDOOR UNIT LEAVING-AIR WB TEMP \_\_\_\_\_

COMPRESSOR 1 AMPS (L1/L2/L3) \_\_\_\_\_ / \_\_\_\_\_ / \_\_\_\_\_

COMPRESSOR 2 AMPS (L1/L2/L3) \_\_\_\_\_ / \_\_\_\_\_ / \_\_\_\_\_

NOTES: \_\_\_\_\_  
\_\_\_\_\_  
\_\_\_\_\_  
\_\_\_\_\_  
\_\_\_\_\_  
\_\_\_\_\_  
\_\_\_\_\_  
\_\_\_\_\_  
\_\_\_\_\_  
\_\_\_\_\_  
\_\_\_\_\_  
\_\_\_\_\_  
\_\_\_\_\_  
\_\_\_\_\_  
\_\_\_\_\_  
\_\_\_\_\_  
\_\_\_\_\_  
\_\_\_\_\_  
\_\_\_\_\_  
\_\_\_\_\_  
\_\_\_\_\_

CUT ALONG DOTTED LINE

CUT ALONG DOTTED LINE