

DUCTLESS SPLIT & VRF ACCESSORIES



Replacement Components
Carrier

Table Of Contents

CONDENSATE REMOVAL PUMPS

MicroBlue Blue Diamond Condensate Pump	3
MaxiBlue Blue Diamond Condensate Pump	3
MegaBlue Blue Diamond Condensate Pump	4
MegaBlue Blue Diamond Condensate Pump	4
MicroBlue Blue Fascia Kit.....	5
Sauermann Si-20 Inline Mini Condensate Pump.....	6
Sauermann Si-30 Compact Mini Condensate Pump.....	7
Sauermann Omega Pack Mini Condensate Pump.....	8
Aspen Mini Aqua Univolt.....	9
Aspen Microv Mini-Split Condensate Pump	9
Aspen Mini-White Univolt Condensate Pump.....	10
Rectorseal Mini Pump Reservoir	10

LINESETS

Black Mini-Split Black Insulated Linesets	11
Black Mini-Split Black Insulated Linesets Plain and Flair Ends.....	12
Black Mini-Split Black Insulated Linesets with 14/4 Wire Plain and Flair Ends	13

INSTALLATION ACCESSORIES

Sauermann Easy Lineset Duct.....	14
Sauermann Wall Bracket with Bar	14
Rectorseal Fortress Lineset Kit	15
Rectorseal Polymer Riser.....	15
Rectorseal Fortress Series Lineset Covers	16
Rectorseal Fit-It-Foot Riser	17
Rectorseal Wall Condensor Bracket.....	18
Rectorseal Slab Condensor Bracket	18
Rectorseal Actabs™ Dmss.....	19
Rectorseal Waterless Trap	19
Rectorseal Aspen Installation Toolbox.....	20
Rectorseal Desolv Cleaning Kit for Mini-Splits	21
Rectorseal Mighty Bracket.....	21
Rectorseal NoKink Flexible Refrigerant Line Connector	22
Rectorseal Polymer Ivory 4” Riser End Cap.....	22
Rectorseal Mini-Split Safety Switch.....	23
Rectorseal 20’ Drain Hose.....	23
Rectorseal Telescoping Wall Sleeve.....	23

CONTROLLERS

Intesis BACnet 1:1 Communication Gateway.....	24
Intesis BACnet 4:1 Communication Gateway.....	25
Cielo Breez Plus Smart Wi-Fi Controller	26

COMPRESSOR OILS

Totaline Polyolvinyl Ether Refrigeration Oil (PVE).....	27
Toshiba Oil.....	27

Condensate Removal Pumps

MICROBLUE® Condensate Pump with 1.3gph

The MicroBlue® uses a revolutionary dynamic diaphragm control technology, allowing it to outperform other condensate pumps. The compact, anti-vibration design makes it suitable for conduit installations or similar discrete locations.



3
YEAR
WARRANTY

PERFORMANCE

- 1.3 gph max. flow
- 16 foot max. head
- 6 foot max. suction lift

INSTALLATION OPTIONS

The MicroBlue can be mounted in any orientation up to 6 ft. away from the air conditioning unit.

STD PK	PART	DESCRIPTION	DBA
30	X86-003	Condensate Pump MicroBlue 1.3gph flow; 115-230v	17

DIMENSIONS ("")

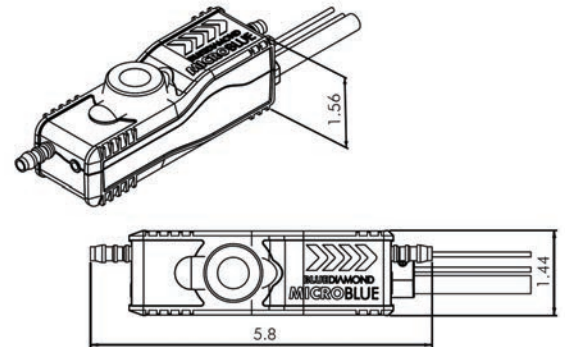

MAXIBLUE® Condensate Pump with 3.7gph

Designed for high humidity environments and with high performance, the MaxiBlue® is ideally suited for mid range air conditioning systems. Its exceptional reliability is backed by a multi year warranty and with class leading performance/suction lift, the MaxiBlue® is ideal for installations in environments that are both demanding and expensive to access for maintenance.



3
YEAR
WARRANTY

PERFORMANCE

- 3.7 gph max. flow
- 23 foot max. head
- 16.5 ft. max. suction lift

INSTALLATION OPTIONS

The MaxiBlue can be mounted in any orientation up to 23 ft. away from the air conditioning unit.

STD PK	PART	DESCRIPTION	DBA
25	X87-711	Condensate Pump MaxiBlue 3.7gph flow; 115v	21
25	X87-721	Condensate Pump MaxiBlue 3.7gph flow; 230v	

DIMENSIONS ("")

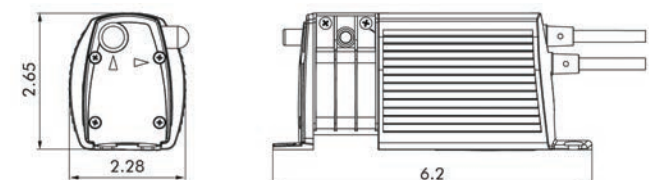

Condensate Removal Pumps

MEGABLUE® Condensate Pump with 13.2gph

The MEGABLUE® has a slimline, lightweight design and is whisper quiet, it also has the performance to overcome installation challenges and uses the BlueDiamond® revolutionary patented principle, making it inherently reliable. With the MEGABLUE® there's no cost penalty up front but big savings on installation and in service beyond.

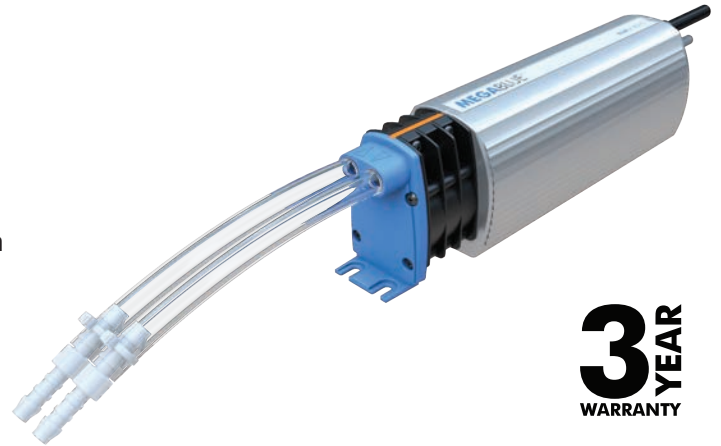

3
YEAR
WARRANTY

PERFORMANCE

- 13.2 gph max. flow
- 66.5 foot max. head
- 23 ft. max. suction lift

INSTALLATION OPTIONS

The MegaBlue can be mounted in any orientation up to 66.5 ft. away from the air conditioning unit.

DIMENSIONS (“)

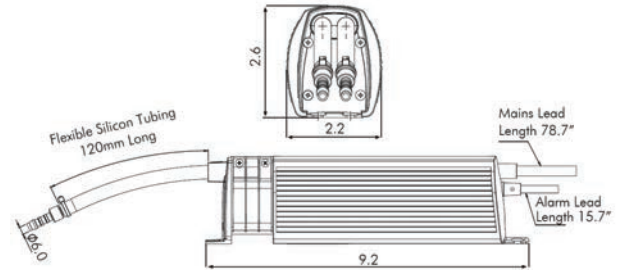

STD PK	PART	DESCRIPTION	DBA
10	X87-835	Condensate Pump MegaBlue 13.2gph flow; 230v	23

Accessories For Condensate Removal Pumps



Sensor Cable Extension



Alarm Cable Extension

STD PK	PART	DESCRIPTION
10	C13-103	16 ft. Sensor Cable Extension
12	C13-192	Alarm Extension Cable

MICROBLUE[®]

Fascia Kit

The BlueDiamond Fascia kit has been specially adapted to fit the MICROBLUE[®] condensate pump. It can accommodate the pump and the new clear reservoir with the ability to hide various cables and tubing at the same time. The Fascia kit has a easy to use detachable cover and sits nicely under any Air Conditioning Unit.

T18-016

PUMP NOT INCLUDED



3
YEAR
WARRANTY

DIMENSIONS (MM)

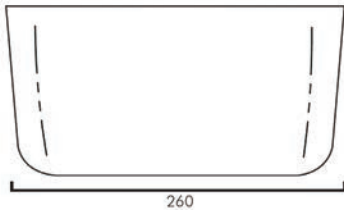
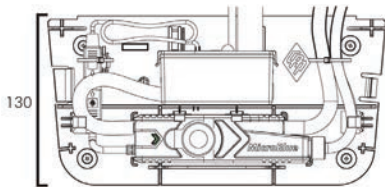

IN THE BOX

- A. Cover (x1)
- B. Base Plate (x1)
- C. Mounting screws (x4)
- D. Wall Plug (x4)
- E. Cable Tie (x1)
- F. A/C Outlet Tube 100mm (x1)
- G. Connector Tube 140mm (x1)

Si-20

Versatile Inline Mini Condensate Removal Pump

Slim design for a quick install inside the air conditioning unit.

SUITABLE FOR

- Up to 5.5 tons
- Wall mounted
- Ducted units
- Suspended ceiling units
- Floor mounted units

KEY FEATURES

- Slim design
- Rubber dampers
- Incredibly quiet
- Drain safe device

PERFORMANCE

- 5 gph max. flow
- 33 ft. max. discharge



STD PK	PART	DESCRIPTION
6	SI20UL01UN12	Si-20 Condensate Pump 120V
6	SI20UL01UN23	Si-20 Condensate Pump 230V

Si-20 Specifications

MAX. FLOW RATE: 5.0 gph	SAFETY SWITCH: NC 8A resistive - 250 V	
MAX. SUCTION HEAD: 10ft	THERMAL PROTECTION: 240°F auto-reset	
MAX. DISCHARGE HEAD: 33ft; flow rate = 1 gph	OPERATING CONDITIONS: 120V - 50%: 3s ON – 3s OFF 230V - 60%: 3s ON – 2s OFF	
MAX. PRESSURE: 46ft; flow rate = 0 gph	PUMP DIMENSIONS: L 5 ³ / ₈ " x W 1 ¹ / ₂ " x H 1 ¹ / ₂ "	
SOUND LEVEL AT 3.3FT: 22 dBA according to EN ISO 3744 (Measured at LNE lab, pump operating with water, out of application)	SAFETY STANDARDS: UL / CSA certified by Intertek	
POWER SUPPLY: 120 V ~ 60 Hz - 14 W (SI20UL01UN12) 230 V ~ 50/60 Hz - 14 W (SI20UL01UN23)	RoHS & WEEE DIRECTIVES: Compliant	
INSULATION CLASS: Double Insulation <input type="checkbox"/>	PACKAGING: 1.1 lbs - L 6 ³ / ₄ " x W 6 ³ / ₈ " x H 2 ⁷ / ₈ "	
DETECTION LEVELS: On: ⁵ / ₈ " • Off: ⁷ / ₁₆ " • Safety: ³ / ₄ "	MASTERPACK: 6 pieces	

ACTUAL FLOW RATES (GPH)

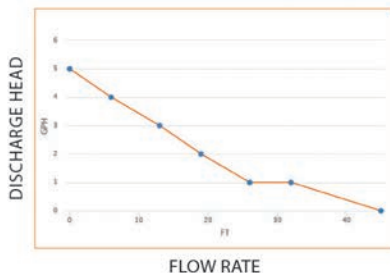

SOUND LEVEL

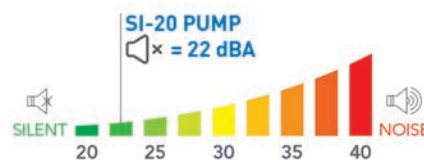

RECOMMENDED ACCESSORIES



- Clear PVC hose, 1/4" i.d.
- ACC 00105: 16ft roll
- ACC 00150: 164ft roll

Connects the pump to the discharge outlet

I.D.: 1/4"

PKG QTY: 16' / 164' roll



- Self-sealing fitting to connect discharge tube to drain pipe.
- 6 pcs, for 1/4" i.d.

STD PK	PART NO.	DESCRIPTION
1	ACC00105	1/4" PVC Tubing 16'
1	ACC00150	1/4" PVC TUBING 164'

Condensate Removal Pumps



Si-30 Compact Mini Condensate Removal Pump

Versatile installation Options, Remotely Above the unit.



SUITABLE FOR

- Up to 5.5 tons
- Wall mounted
- Ducted units
- Suspended ceiling units
- Floor mounted units

KEY FEATURES

- Mounting bracket
- Locking power cord
- Drain safe device
- Versatile installation options

STD PK	PART	DESCRIPTION
20	SI30UL01UN12	Si-30 Condensate Pump 120V
20	SI30UL01UN23	Si-30 Condensate Pump 230V

PERFORMANCE

- 5 gph max. flow
- 33 ft. max. discharge

Si-30 Specifications

MAX. FLOW RATE: 5.0 gph	DETECTION LEVELS: On: 5/8" • Off: 7/16" • Safety: 3/4"	
MAX. SUCTION HEAD: 10ft	SAFETY SWITCH: NC 8A resistive - 250 V	
MAX. DISCHARGE HEAD: 33ft; flow rate = 1 gph	THERMAL PROTECTION: 240°F auto-reset	
MAX. PRESSURE: 46ft; flow rate = 0 gph	OPERATING CONDITIONS: 70%: 3s ON – 1s OFF	
SOUND LEVEL AT 3.3FT: 20 dBA according to EN ISO 3744 (Measured at LNE lab, pump operating with water, out of application)	PUMP DIMENSIONS: L 2 5/8" x W 1 3/4" x H 2 3/8"	
POWER SUPPLY: 120 V ~ 60 Hz - 14 W (SI30UL01UN12) 230 V ~ 50/60 Hz - 14 W (SI30UL01UN23)	SAFETY STANDARDS: UL / CSA certified by Intertek	
INSULATION CLASS: Double Insulation <input type="checkbox"/>	RoHS & WEEE DIRECTIVES: Compliant	
	PACKAGING: 1.1 lbs - L 5 5/16" x W 5 5/16" x H 3 17/32"	
	MASTERPACK: 20 pieces	

SOUND LEVEL

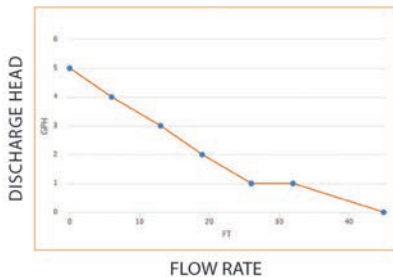

ACTUAL FLOW RATES (GPH)

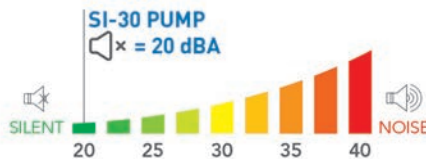

RECOMMENDED ACCESSORIES



- Clear PVC hose, 1/4" i.d.
- ACC 00105: 16ft roll
- ACC 00150: 164ft roll

Connects the pump to the discharge outlet

I.D.: 1/4"

PKG QTY: 16' / 164' roll



- Self-sealing fitting to connect discharge tube to drain pipe.
- 6 pcs, for 1/4" i.d.

STD PK	PART NO.	DESCRIPTION
1	ACC00105	1/4" PVC Tubing 16'
1	ACC00150	1/4" PVC TUBING 164'

Omega Pack

MINI CONDENSATE REMOVAL PUMP

The performance of our Si-20 with a sleek case for install under the air conditioning unit.



SUITABLE FOR

- Up to 5.5 tons
- Wall mounted units

KEY FEATURES

- Modern design
- Reversible mounting
- Rubber dampers
- Drain safe device

PERFORMANCE

- 5 gph max. flow
- 33 ft. max. discharge

STD PK	PART	DESCRIPTION
6	OP20UL01UN12	Omega Pack 120V
6	OP20UL01UN23	Omega Pack 230V

OMEGA PACK TECH SPECS

MAX. FLOW RATE: 5.0 gph	SAFETY SWITCH: NC 8A resistive - 250 V	
MAX. DISCHARGE HEAD: 33ft; flow rate = 1 gph	THERMAL PROTECTION: 240°F auto-reset	
MAX. PRESSURE: 46ft; flow rate = 0 gph	OPERATING CONDITIONS: 120V - 50%: 3s ON – 3s OFF 230V - 60%: 3s ON – 2s OFF	
SOUND LEVEL AT 3.3FT: 22 dBA according to EN ISO 3744 (Measured at LNE lab, pump operating with water, out of application)	COLOR: RAL 9010 – Pure white	
POWER SUPPLY: 120 V ~ 60 Hz - 14 W (OP20UL01UN12) 230 V ~ 50/60 Hz - 14 W (OP20UL01UN23)	COVER DIMENSIONS: L 12 ⁷ / ₈ " x W 2 ¹ / ₄ " x H 2 ¹ / ₂ "	
INSULATION CLASS: Double Insulation <input type="checkbox"/>	SAFETY STANDARDS: UL / CSA certified by Intertek	
DETECTION LEVELS: On: 5/8" • Off: 7/16" • Safety: 3/4"	RoHS & WEEE DIRECTIVES: Compliant	
	PACKAGING: 1.61 lbs - L 14 ¹ / ₈ " x W 3 ³ / ₈ " x H 4"	
	MASTERPACK: 6 pieces	

ACTUAL FLOW RATES (GPH)

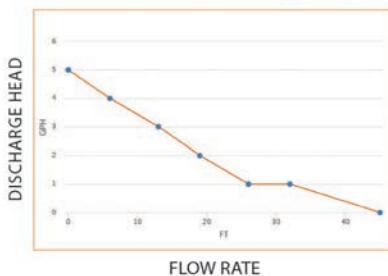

SOUND LEVEL

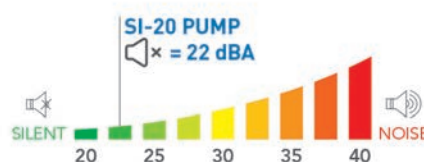

RECOMMENDED ACCESSORIES



- Clear PVC hose, 1/4" i.d.
- ACC 00105: 16ft roll
 - ACC 00150: 164ft roll



- Self-sealing fitting to connect discharge tube to drain pipe.
- 6 pcs, for 1/4" i.d.

Connects the pump to the discharge outlet

I.D.: 1/4"
PKG QTY: 16' / 164' roll

STD PK	PART NO.	DESCRIPTION
1	ACC00105	1/4" PVC Tubing 16'
1	ACC00150	1/4" PVC TUBING 164'

Condensate Removal Pumps



ASPEN MINI AQUA UNIVOLT



FEATURES

- Ultra-slim profile
- Self Priming
- Integral hanging loop and separate reservoir facilitates attachment in vertical applications
- 3A NO/NC dry contacts rated at 5A inductive at 230V AC
- Fully potted electronics

SPECIFICATIONS

Power Supply: 100-250 VAC
 Power Consumption: .07-.13A
 16W

- 50% duty cycle
- 5 mins on/5 mins off

Pump Dimensions:
 L-61/2" x H-11/8" x W-11/8"

Capacity:

- Up to 54,600 BTU/hr.
- 3.2 GPH at zero head
- 1.2 GPH at 33 ft. head

Maximum head: 33 ft.

Suction lift: 5 ft.

Sound level: Mini – 24dB(A)

STD PK	PART	DESCRIPTION
100	83809	Aspen Mini Aqua Univolt Condensate Pump

ASPEN MICROV MINI-SPLIT CONDENSATE PUMP

Ideal for mini-split condensate management application requiring compactness, high capacity/low noise.



FEATURES

- Compatible with all mini-split air conditioners brands/ models
- Silent+ Univolt technology Plug and Play connections
- 3A NC dry contacts rated at 5A inductive at 230V AC
- Self priming

SPECIFICATIONS

Duty Cycle:

- 50% duty cycle
- 5 mins on/5 mins off

Capacity:

- Up to 66,000 BTU/hr.
- 3.8 GPH @ zero head
- 1.2 GPH @ 33ft head

Maximum head: 33 ft.

Suction lift: 6.6 ft.

Sound level: Mini – 24dB(A)

Silent Plus: 21dB(A)

STD PK	PART	DESCRIPTION
100	83949	Aspen MicroV Univolt Silent+ Univolt Condensate Pump

Condensate Removal Pumps



ASPEN MINI WHITE UNIVOLT CONDENSATE PUMP



FEATURES

- Surface mounts below evaporator at either end
- Crisp white color and slim profile complement any evaporator. Additional colors available.
- Resilient mounting minimizes vibration & noise
- Accepts standard 5/8" drain hose from any mini-split
- Extra large reservoir capacity minimize pump operation
- All components clip apart for easy disassembly without tools
- Extra large reservoir capacity minimize pump operation
- Fully potted electronics
- No need to disturb evaporator to clean filter, reservoir clips out from front for easy removal and replacement
- 3A N/C dry contacts rated at 5A inductive at 230V AC

SPECIFICATIONS

Power Supply: 100-250 VAC

Power Consumption: 11-18A 16W

Duty Cycle: Continuous

n 5 mins on/5 mins off

Capacity:

• Up to 54,600 BTU/hr.

• 3.2 GPH at zero head

• 1.2 GPH at 33 ft. head

Maximum head: 33 ft.

Maximum Water Temp: 104° F

Sound level: Mini – 25dB(A)

STD PK	PART	DESCRIPTION
100	83939	Aspen Mini Aqua Univolt Condensate Pump

Mini Pump Reservoir

Install before the reservoir on Aspen pumps. Helps protect pump from damage due to dirt and debris in condensate water. Increases time intervals between maintenance visits.

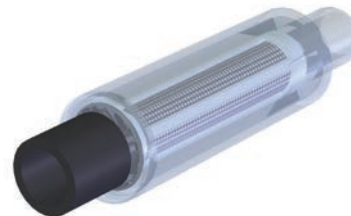

STD PK	PART	DESCRIPTION
1	83180	EZT-180 5/8" Waterless Trap



Linesets Inc. is an industry leader in custom linesets. Their ongoing commitment to listening and work with customers allows them to provide innovated solutions of the highest quality and value. Every product design they offer reflects their many years of industry insight and service excellence.

FAST SERVICE, SHIPMENTS MADE IN DAYS, NOT WEEKS!

- No minimums!
- Packaging design saves space and reduces cost
- No Master Carton Quantity Requirements
- Engineered and tested for use with R410A
- Quality tube for good flexibility/ reduced kinking
- Better processes provide for consistent product
- Multiple custom and value adding options available
- VRF Specialists
- E243 approved
- 75 line sets for FFA
- Made in USA

VALUE ADDED OPTIONS

- Custom lengths up to 100 ft. (1-1/8" up to 50')
- Wire and/or control cable pre-assembly
- Tear and UV resistant white InsulArmour 360 PE
- Dual tube or twin tube insulation for mini splits
- Flare and other end line fitting options
- Custom ends (90° bends or straight)
- Mix or match pallet packaging options

DIRECT SHIP FFA 75+ PCS. FREIGHT APPLIED ON LESS THAN 75 PCS.

Other special quotes are available upon request.

FULLY ASSEMBLED LINE SET



FULLY ASSEMBLED LINE SET



BLACK MINI-SPLIT LINESETS

PART	SIZE	DESCRIPTION	STD PK
MS-14383825	1/4 X 3/8 X 3/8 X 25' Blk	PLAIN END	1
MS-143838251	1/4 X 3/8 X 3/8 X 25' Flr Blk	FLARE	1
MS-14383850	1/4 X 3/8 X 3/8 X 50' Blk	PLAIN END	1
MS-143838501	1/4 X 3/8 X 3/8 X 50' Flr Blk	FLARE	1
MS-14123825	1/4 X 1/2 X 3/8 X 25' Blk	PLAIN END	1
MS-141238251	1/4 X 1/2 X 3/8 X 25' Flr Blk	FLARE	1
MS-14123850	1/4 X 1/2 X 3/8 X 50' Blk	PLAIN END	1
MS-141238501	1/4 X 1/2 X 3/8 X 50' Flr Blk	FLARE	1
MS-14381225	1/4 X 3/8 X 1/2 X 25' Blk	PLAIN END	1
MS-143812251	1/4 X 3/8 X 1/2 X 25' Flr Blk	FLARE	1
MS-14381250	1/4 X 3/8 X 1/2 X 50' Blk	PLAIN END	1
MS-143812501	1/4 X 3/8 X 1/2 X 50' Flr Blk	FLARE	1
MS-14121225	1/4 X 1/2 X 1/2 X 25' Blk	PLAIN END	1
MS-141212251	1/4 X 1/2 X 1/2 X 25' Flr Blk	FLARE	1
MS-14121250	1/4 X 1/2 X 1/2 X 50' Blk	PLAIN END	1
MS-141212501	1/4 X 1/2 X 1/2 X 50' Flr Blk	FLARE	1
MS-38581225	3/8 X 5/8 X 1/2 X 25' Blk	PLAIN END	1
MS-385812251	3/8 X 5/8 X 1/2 X 25' Flr Blk	FLARE	1
MS-38581250	3/8 X 5/8 X 1/2 X 50' Blk	PLAIN END	1
MS-385812501	3/8 X 5/8 X 1/2 X 50' Flr Blk	FLARE	1
MS-14383425	1/4 X 3/8 X 3/4 X 25' Blk	PLAIN END	1
MS-143834251	1/4 X 3/8 X 3/4 X 25' Flr Blk	FLARE	1
MS-14383450	1/4 X 3/8 X 3/4 X 50' Blk	PLAIN END	1
MS-143834501	1/4 X 3/8 X 3/4 X 50' Flr Blk	FLARE	1
MS-14123425	1/4 X 1/2 X 3/4 X 25' Blk	PLAIN END	1
MS-141234251	1/4 X 1/2 X 3/4 X 25' Flr Blk	FLARE	1
MS-14123450	1/4 X 1/2 X 3/4 X 50' Blk	PLAIN END	1
MS-141234501	1/4 X 1/2 X 3/4 X 50' Flr Blk	FLARE	1
MS-38583425	3/8 X 5/8 X 3/4 X 25' Blk	PLAIN END	1
MS-385834251	3/8 X 5/8 X 3/4 X 25' Flr Blk	FLARE	1
MS-38583450	3/8 X 5/8 X 3/4 X 50' Blk	PLAIN END	1
MS-385834501	3/8 X 5/8 X 3/4 X 50' Flr Blk	FLARE	1



NOTE: Linesets and copper are not available to ship outside of the Continental USA

BLACK MINI-SPLIT LINESETS WITH 14/4 WIRE

PALLET PACKAGING

PART	SIZE	DESCRIPTION	STD PK
MS-14383825T144	1/4 X 3/8 X 3/8 X 25' Blk	PLAIN END	1
MS-14383825T144	1/4 X 3/8 X 3/8 X 25' Flr Blk	FLARE	1
MS-14383850T144	1/4 X 3/8 X 3/8 X 50' Blk	PLAIN END	1
MS-14383850T144	1/4 X 3/8 X 3/8 X 50' Flr Blk	FLARE	1
MS-14123825T144	1/4 X 1/2 X 3/8 X 25' Blk	PLAIN END	1
MS-14123825T144	1/4 X 1/2 X 3/8 X 25' Flr Blk	FLARE	1
MS-14123850T144	1/4 X 1/2 X 3/8 X 50' Blk	PLAIN END	1
MS-14123850T144	1/4 X 1/2 X 3/8 X 50' Flr Blk	FLARE	1
MS-14381225T144	1/4 X 3/8 X 1/2 X 25' Blk	PLAIN END	1
MS-14381225T144	1/4 X 3/8 X 1/2 X 25' Flr Blk	FLARE	1
MS-14381250T144	1/4 X 3/8 X 1/2 X 50' Blk	PLAIN END	1
MS-14381250T144	1/4 X 3/8 X 1/2 X 50' Flr Blk	FLARE	1
MS-14121225T144	1/4 X 1/2 X 1/2 X 25' Blk	PLAIN END	1
MS-14121225T144	1/4 X 1/2 X 1/2 X 25' Flr Blk	FLARE	1
MS-14121250T144	1/4 X 1/2 X 1/2 X 50' Blk	PLAIN END	1
MS-14121250T144	1/4 X 1/2 X 1/2 X 50' Flr Blk	FLARE	1
MS-38581225T144	3/8 X 5/8 X 1/2 X 25' Blk	PLAIN END	1
MS-38581225T144	3/8 X 5/8 X 1/2 X 25' Flr Blk	FLARE	1
MS-38581250T144	3/8 X 5/8 X 1/2 X 50' Blk	PLAIN END	1
MS-38581250T144	3/8 X 5/8 X 1/2 X 50' Flr Blk	FLARE	1
MS-14383425T144	1/4 X 3/8 X 3/4 X 25' Blk	PLAIN END	1
MS-14383425T144	1/4 X 3/8 X 3/4 X 25' Flr Blk	FLARE	1
MS-14383450T144	1/4 X 3/8 X 3/4 X 50' Blk	PLAIN END	1
MS-14383450T144	1/4 X 3/8 X 3/4 X 50' Flr Blk	FLARE	1
MS-14123425T144	1/4 X 1/2 X 3/4 X 25' Blk	PLAIN END	1
MS-14123425T144	1/4 X 1/2 X 3/4 X 25' Flr Blk	FLARE	1
MS-14123450T144	1/4 X 1/2 X 3/4 X 50' Blk	PLAIN END	1
MS-14123450T144	1/4 X 1/2 X 3/4 X 50' Flr Blk	FLARE	1
MS-38583425T144	3/8 X 5/8 X 3/4 X 25' Blk	PLAIN END	1
MS-38583425T144	3/8 X 5/8 X 3/4 X 25' Flr Blk	FLARE	1
MS-38583450T144	3/8 X 5/8 X 3/4 X 50' Blk	PLAIN END	1
MS-38583450T144	3/8 X 5/8 X 3/4 X 50' Flr Blk	FLARE	1



NOTE: Linesets and copper are not available to ship outside of the Continental USA

Easy Lineset Duct

FOR MINI SPLITS AND CONVENTIONAL SPLIT SYSTEMS

Use our duct product to protect the linesets against deterioration due to climatic conditions. Everything you need for a typical job in one convenient kit!

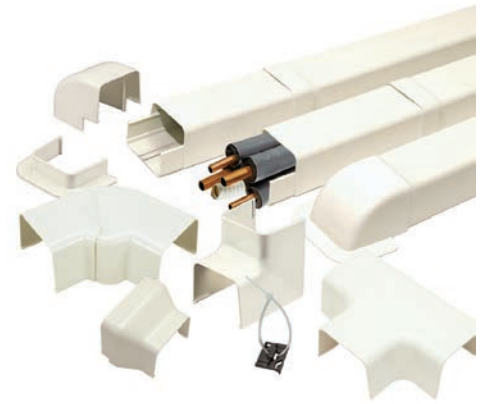

KEY FEATURES

- Impact resistant
- UV resistant
- Wide temperature range
- Snap together/Quick and easy
- Removable protective film
- Snap together/Quick and easy
- Less time & labor costs
 - One person can quickly & easily install
 - Unique clips & tie wraps keep tubing in place during installations

STD PK	PART	DESCRIPTION
6	ED3000SIUS00	Lineset Duct Kit 3"
6	ED4000SIUS00	Lineset Duct Kit 4"

EASY INSTALL

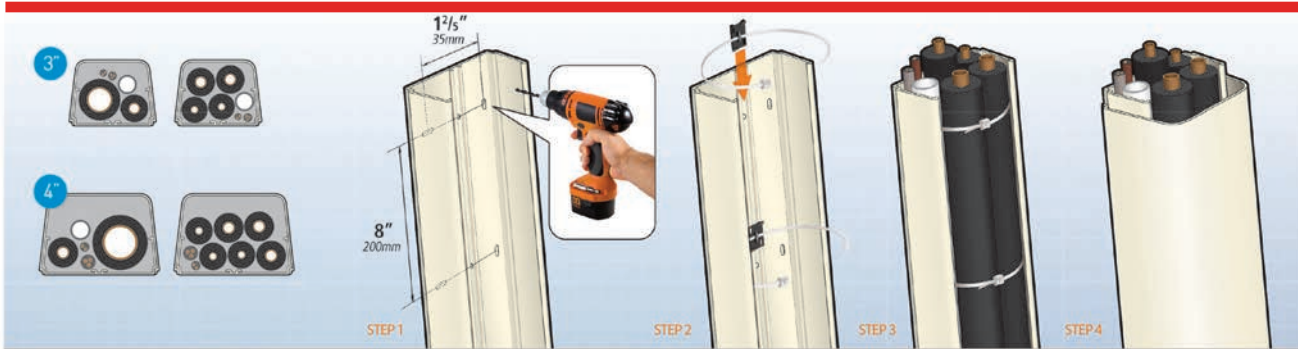

ADJUSTABLE WALL BRACKET WITH BAR

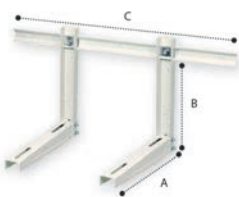

Adjustable wall bracket with bar. Supplied with screws, washers, & anchors.

CAPACITY: 660 lbs / 300 kg

Model	Material	Dimension (mm) (AxBxC)	Dimension (inch) (AxBxC)	Pallet/Ctn (pcs)
BS520HDFKDB	Gal. Steel	520x400x960	19 1/8"x15 1/4"x37 1/8"	117

STD PK	PART NO.	DESCRIPTION
1	BS520HDFKDB	Wall Bracket With Bar

FORTRESS LINESET KIT

Kit includes 12' of duct and fittings for a standard installation.



LDK KIT INCLUDES:

- LD - Ducting 4' Long (3)
- LJ - Couplers (2)
- LW - Wall Inlet (1)
- LEN - End Fitting (1)
- LK - 90° Flat Ell (1)

FEATURES

- Assures complete flexibility of installation
- Professional grade ducting, protects and hides unsightly mini-splits linesets in a snap
- Fortress is perfect for mini-split, high velocity and conventional split air conditioning systems
- Fortress protects lineset, wiring and drain hose from weather, vandalism, pet and pest damage
- Fortress installs quickly, and can be easily accessed for repairs or replacement of the lineset

STD PK	PART	DESCRIPTION
1	84005	Fortress Lineset Cover Kit - White 3.5"
1	84105	Fortress Lineset Cover Kit - White 4.5"

POLYMER RISER

Polymer Ivory 4" Riser - 14" or 18" Long, 308 lb. capacity

FEATURES

- Provides simple and secure mounting for small and large piping systems, ductwork runs, cable trays and smaller equipment such as condensers. Linear track offers adjustable mounting.
- Manufactured from exterior grade materials.



STD PK	PART	DESCRIPTION
20	87761	Polymer Riser 14"
20	87762	Polymer Riser 18"

Fortress Series Lineset Covers

Rectorseal Fortress® lineset cover series was specifically developed to bridge the gap between the lightweight and the more costly lineset cover products available on the market. Made in the USA, Fortress has a number of innovations to suit the USA conditions - such as 8' lengths of duct and a 12 month guarantee. Available in 2 sizes and 4 different colors. Fortress offers the strength and longevity at a moderate price point.

STD PK	PART	DESCRIPTION
6	84120	4 1/2" 45 Degree Inside Vert
6	84121	4 1/2" 45 Degree Outside Vert
6	84122	4 1/2" 90 Degree Inside Vert
6	84123	4 1/2" 90 Degree Outside Vert
6	84124	4 1/2" Ducting 8' Length 122
1	84125	12' Wall Duct Kit Ld 122
6	84127	4 1/2" End Fitting 122
6	84128	4 1/2" Flexible Ell 122
6	84129	4 1/2" Flexible Adapter 122
6	84130	4 1/2" Coupler 122
6	84131	4 1/2" 90 Degree Flat Ell 122
6	84132	4 1/2" 45 Degree Flat Ell 122
6	84133	4 1/2" 90 Degree Sweep Ell 122
6	84134	4 1/2" Soffit Inlet 122
6	84135	4 1/2" Tee 122
6	84136	4 1/2" Wall Inlet 122
6	84137	4 1/2" Wall Flange 122



84128



84130



84134



84129

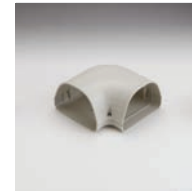

84131



84135



84120



84132



84136



84127



84133



84121



84124



84137



84132



84122



84125

FIT-IT-FOOT

Fix-It-Foot 4" Riser with Channel - 10", 16", 24" Long, 440 lb. capacity

FEATURES

- Ideal for rooftop support of equipment and systems. Similar to our low profile model, these risers have additional vibration isolation due to their increased height. Their extra weight will increase stability. Mounting is strong, secure, flexible, vibration absorbing and leak proof while keeping installation quick, practical and aesthetically pleasing. Aluminum linear track permits the use of standard strut hardware (not included). Underside has recessed area to permit easy leveling. Molded from recycled crumb rubber.

STD PK	PART	DESCRIPTION
1	87771	Fit-It-Foot 10"
1	87773	Fit-It-Foot 16"
1	87775	Fit-It-Foot 24"



WALL CONDENSOR BRACKET

Made from heavy duty steel with powdercoat finish. The WBB300 features a sliding cross bar for exceptional equipment width range and a level for added convenience.



300 LB. CAPACITY

SPECIFICATIONS

- Material: Steel
- Coating: Powdercoat
- Capacity: 300 lb.
- Length: 22"
- Width: 33.5"
- Height: 18"

500 LB. CAPACITY

SPECIFICATIONS

- Material: Steel
- Coating: Powdercoat
- Capacity: 500 lb.
- Length: 24"
- Width: 33.5"
- Height: 18"

STD PK	PART	DESCRIPTION
1	87733	Wall Bracket 300 lb.
1	87735	Wall Bracket 500 lb.

SLAB STAND CONDENSER BRACKET

Made from heavy duty steel with powdercoat finish. This stand raises the condenser up to 12" above a flat surface. Each leg is independently adjustable for uneven surfaces and has anti slip rubber feet.



176 LB. CAPACITY

SPECIFICATIONS

- Material: Steel
- Coating: Powdercoat
- Capacity: 176 lb.
- Length: 31.75"
- Width: 15"
- Height: 12.5"

STD PK	PART	DESCRIPTION
1	87743	Slab Stand

ACTABS™ DMSS

Actabs DMSS is an EPA registered biocide evaporator pan treatment specifically formulated for ductless mini-split evaporator units to eliminate or prevent most blockages in drain pans, reservoirs and drain pans due to the buildup of mold, bacterial slime, rust, scale, sludge, air-borne dust, silt and other solids. Compatible with all condensate pumps. Helps stop damage to floors, ceilings and equipment.



CHARACTERISTICS

- EPA Registered
- Prevents costly water overflow damage
- Easy to Use
- Eliminates the bacteria-caused bad odors

STD PK	PART	DESCRIPTION
12	68107	ACTABS DMSS (200)

Waterless Trap

Our Waterless Traps eliminate standing water curing your freezing problems. Being only 2.75" long it can be used in any Mini-split evaporator and while permitting free flow it will block odors, noise and insects.



STD PK	PART	DESCRIPTION
1	83180	EZT-180 5/8" Waterless Trap

Aspen Installation Toolbox

STD PK	PART	DESCRIPTION
1	83999	Aspen Xtra Cont. Installation Accy 39 pc. Toolbox



CODE	MODEL	DESCRIPTION	QTY
Mini Pump Rubber Adapter/Connector			
83970	FP2001	5/8" Mini Pump to 3/4" ducted drain (16mm-20mm)	2
83971	FP2002	5/8" mini pump to 1" ducted drain (16mm-25mm)	2
83972	FP2003	5/8" mini pump to 1-1/4" ducted drain (16mm-32mm)	2
Mini Pump 90° Long Arm Bend Connector			
83973	FP2006	1/2" to 5/8" (12mm-16mm) long arm	2
Pipe to Pipe Rubber Connector			
83977	FP2042	3/4" PVC to 5/8" (20mm-16mm)	2
83978	FP2044	3/4" PVC to 1" (20mm-25mm)	2
83979	FP2046	3/4" PVC to 1-1/4" (20mm-32mm)	2
Hose to Hose Connectors			
83984	FP2024	1/4" "T" connectors (6mm)	3
83985	FP2028	1/4" elbow connectors (6mm)	4
83986	FP2622	1/4" straight connectors (6mm)	3
83987	FP2030	3/8" "T" connectors (10mm)	3
83988	FP2032	3/8" elbow connectors (10mm)	3
83989	FP2624	3/8" straight connectors (10mm)	3
Tube Adapter/Fitting			
83990	FP2038	3/8" or 1/4" (10mm/6mm) self sealing soil pipe connector	2
Check Valves			
83982	FP2628	1/4" Non Return Valves (6mm)	2
83983	FP2630	3/8" Non Return Valves (10mm)	2

Desolv Cleaning Kit for Mini-Splits

Use to deep clean the indoor evaporator of mini-split A/C units that are located in areas where wall and floor protection are necessary. Kit is reusable. The replacement single-use funnel bags are for single-use only.

KIT CONTENTS

- Desolv Cleaning Solution (1 gal.)
- C-Band Frame Assembly
- Single-Use Replacement Bags (2)
- Wedge Sheets (2)
- Drain Pail (5 gal)
- Installations Instructions

STD PK	PART	DESCRIPTION
1	82560	Desolv Cleaning Kit



Mighty Bracket

RectorSeal Corp., Houston, a leading manufacturer of quality HAC/R products, introduces the Mighty Bracket, the HVAC industry's firm mini-split installation support tool. Mighty Bracket cuts jobsite labor costs by 50-percent because it reduces evaporator coil mounting and connecting to a hands-free, single-person task.

The contractor-grade yellow, patent-pending Mighty Bracket hooks onto both tabs of a mini-split wall mounting plate in less than a minute. The Mighty Bracket securely holds the mini-split evaporator coil for quick and easy connections of electrical, refrigeration line sets and condensate drain pumps/hoses. The 20-inch long support arms are roomy enough to allow evaporator coils to be temporarily angled away from the wall at 23 to 45-degrees for easy back panel access during installation or servicing.

FEATURES

- Soft gasket material on support feet and support arms protect wall surfaces and evaporator coil encasement finishes from scratches
- Flip-up gates at the end of both support arms helps to prevent slip off and damage to the evaporator or flooring below
- Horizontal leveling of support arms is accomplished by sliding an included cotter pin into four adjustment hole selections
- Pays for itself in labor savings after just one installation
- Four-color, fully-illustrated glossy packaging box can easily be displayed on wholesaler end caps, shelves or counters
- Rounded corners prevent worker injury from sharp edges



STD PK	PART	DESCRIPTION
1	97705	Mighty Bracket

NoKink Flexible Refrigerant Line Connector

NoKink is used when installing air conditioning units when connecting either the evaporator or condenser unit and is ideal for DMSS especially when connecting the evaporator unit.

It allows the contractor to easily install the refrigerant lines coming out of the wall to the DMSS evaporator. It prevents the refrigerant line from kinking and allows for an easier installation saving time and labor costs. Each NoKink has a 3" long copper end for easier flaring.



STD PK	PART	DESCRIPTION
4	66731	NoKink 1/4" dia. x 3' Length
4	66733	NoKink 3/8" dia. x 3' Length
4	66737	NoKink 1/2" dia. x 3' Length
4	66735	NoKink 5/8" dia. x 3' Length
4	66732	NoKink 3/4" dia. x 3' Length
4	66734	NoKink 7/8" dia. x 3' Length

Polymer Ivory 4" Riser End Cap

End Caps are the perfect detail to complete an install. One size fits all.

STD PK	PART	DESCRIPTION
1	87765	4" Polymer Riser End Caps (1 pair)

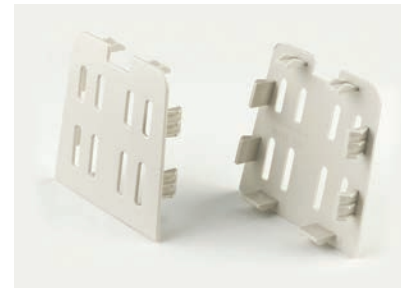

Mini-Split Safety Switch

FEATURES

- Sensor connects to indoor units
- Onboard LED indicator can be mounted to side of unit
- Univolt input 15-250 Vac 15-100 Vdc

APPLICATION

- Designed for mini-split systems
- For installation directly on primary drain pan or clipped to coils above primary drain pan
- Multi-voltage
- Can be wired in both normally open and normally closed systems
- No batteries required



STD PK	PART	DESCRIPTION
12	97622	SS610E Mini-Split Safety Switch

Standard Drain Hose

Non-Insulated Hose

16 mm (5/8"Ø Drain Hose 20' Retail Pack Standard weight drain hose in retail pack

STD PK	PART	DESCRIPTION
5	83003	5/8" Standard Drain Hose 20'



Telescoping Wall Sleeve

Telescoping Wall Sleeve 3"x 5" - 7 3/4" used to provide a seal when penetrating walls. ID - 3" PD - 2 7/8"

STD PK	PART	DESCRIPTION
1	83017	Telescoping Wall Sleeve



BACnet 1:1 MS/TP GATEWAY

The Intesis BACnet gateway connects a single Ductless Indoor Unit to a BACnet control system allowing bi-directional control and monitoring.

DIRECT CONNECTION TO INDOOR UNITS

The gateway is wired directly to the Ductless indoor unit. This allows not only the control of the main AC functions such as operating mode, fan speed, temperature setpoint, but the monitoring of errors, alarms and some internal variables.

FAST AND EASY TO SET UP BY DIP-SW

The product can be installed and set up in a really short time. It's only a matter of wiring the gateway to the AC unit, connect 12 VDC/AC power supply (field-supplied) and configure the DIP-SW accordingly. No configuration software is required.

Standard Features

- BTL mark ensures full interoperability with BACnet devices.
- Supports only BACnet MS/TP.
- Simultaneous control of the AC unit by Carrier Wired / IR remote (depending on type of unit) and BACnet MS/TP.
- Factory Wired/IR remotes can be disabled to only allow BACnet control.
- Occupancy function allows energy savings.
- Quick and easy installation (connect and set the DIP-Switches).
- Total control and monitoring of the AC unit from BACnet, including AC unit's internal variables, running hours counter (for filter maintenance control) and indoor unit error codes.



- Bidirectional communication of Air Conditioning unit properties and functionalities as BACnet Objects.
- 12 VDC/AC power supply required. (Field Procured)
- Mountable on DIN rail, wall, or Field Procured enclosure
- Reduced dimensions 93 x 53 x 58 mm
- Configured with on board DIP-Switches, no software required

Compatibility

Only specific Carrier DLS indoor product families are tested for compatibility with the Intesis BACnet MS/TP 1:1 gateway INBACMID0011100. Ductless indoor unit backward compatibility as well as future versions' compatibility is not guaranteed.

Carrier DLS Indoor Family	Compatibility
Entry Tier High Wall 40MHHQ(size 09-24)---3	Yes
High Tier High Wall 40MPHAQ(size 09-24)XA3	Yes
Mid Tier Cassette 40MBCQ(size09-24)---3	Yes
Mid Tier Ducted 40MBDQ(size09-24)---3	Yes
Mid Tier High Wall 40MAQB(size09-24)B---3	Yes* (see * note below)

*The current mid-tier Ductless High Wall 40MAQB**B---3 indoor unit will need to have the display and adaptor board to function with the Intesis BACnet MS/TP gateway. The 40MAQ Adapter Board, P/N 17222000A50275, and Display Board Assembly, P/N 17222000A17852, can be ordered from RC.

** Any third party product purchased from Carrier carries solely the warranty from the manufacturer of that product, if any. Carrier does not warrant performance of such product beyond the manufacturer's warranty, if applicable, to customers and end users of this product. Carrier disclaims all other warranties, express or implied, including with respect to security, and further disclaims all liability arising out of or in connection third party systems and equipment.

BACnet 4:1 IP/MSTP GATEWAY

The Intesis BACnet Gateway connects up to 4 Ductless Indoor Units to a BACnet control system allowing bidirectional control and monitoring.

DIRECT CONNECTION TO INDOOR UNITS

The gateway is wired directly to the X/Y/E bus of the Ductless indoor units. This allows control of the main AC functions such as operating mode, fan speed, temperature setpoint, plus the monitoring of errors and alarms.

FAST AND EASY TO SET UP WITH INTESIS MAPS

Site configurations can be completed quickly using Intesis MAPS (Freeware) tool. It's only a matter of wiring the gateway to the AC units, connecting a power supply and then connecting your laptop to the gateway.

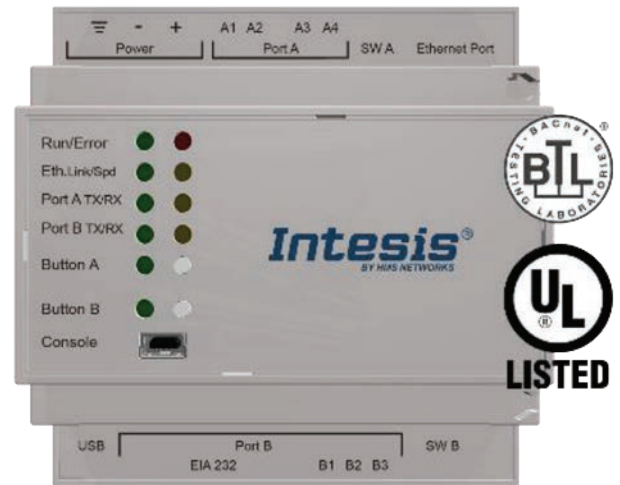

Standard Features

- UL Certified
- BTL Certified which ensures full interoperability with BACnet devices
- Supports both BACnet/IP and BACnet MSTP physical layers.
- Supports up to 4 Ductless indoor units with individual controls for each indoor unit.
- Simultaneous control of the AC unit by Carrier Wired/IR remote (depending on type of indoor unit) and BACnet.
- Factory Wired/IR remotes can be disabled to only allow BACnet control.
- Easy installation using Intesis MAPS (Freeware) Tool to auto scan network to identify connected
- Ductless Units for site configuration and includes advanced diagnostic tools.
- Total control and monitoring of the AC unit from BACnet, including AC unit's internal variables, running hours counter (for filter maintenance control) and indoor unit error codes.
- Bidirectional communication of Air Conditioning unit properties and functionalities as BACnet Objects.
- 9-36 vdc (140ma) or 24 vac (127ma) power supply required. (Field Procured)
- Mountable on DIN rail, wall, or enclosure (Field Procured)
- Dimensions 90 x 88 x 56 mm
- Configuration through IP or USB (Console) port.
- Front cover LEDs provide easy visual status of both the Ethernet and serial ports communication activity.
- Automatic updates for both Intesis MAPS and interface's firmware.

Compatibility

Only specific Carrier DLS indoor product families are tested for compatibility with the Intesis BACnet 4:1 gateway INBACMID004I000. Ductless indoor unit backward compatibility as well as future versions' compatibility is not guaranteed.

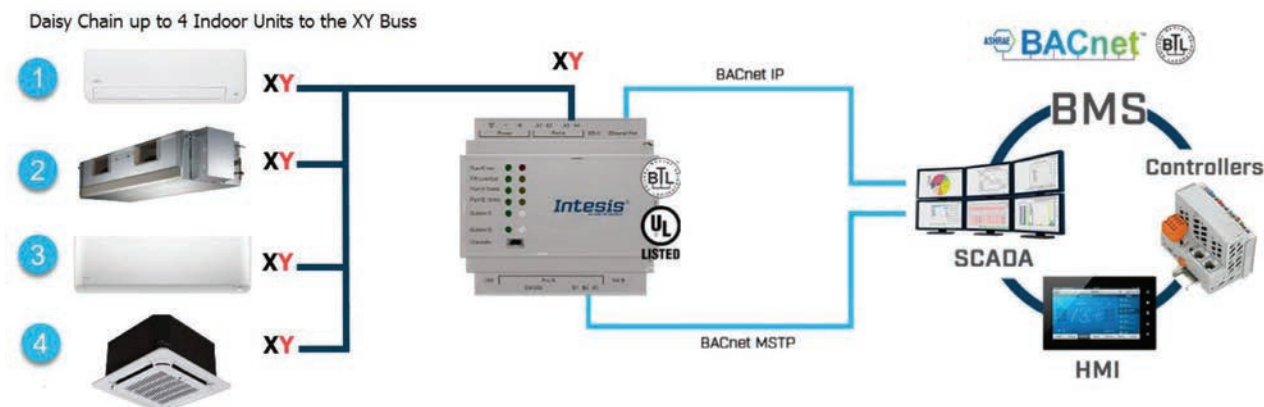

Cielo Breez Plus WiFi Controller BP101WA

Cielo Breez Plus Smart AC controller works with mini splits, portable ACs and window ACs that have a remote control. It connects to the Wi-Fi router and let you control your air conditioners with smart phone, Amazon Alexa or the Google Home from anywhere and anytime.

GO global or remain local - Choice is yours: Initially register the device using your Wi-Fi, afterwards you can also control your connected AC even without WiFi. Cielo Breez Plus helps you create zones for efficient heating or cooling, thus saves you on the AC's energy bills. It enhances your lifestyle, comfort, and convenience.



Applications

- ✓ Homes (Mobile apps and used as wireless controller)
- ✓ Vacation Rentals (Enterprise web app & option as wired controller)
- ✓ Hotels (Enterprise web app & option as wired controller)
- ✓ Warehouses (Enterprise web app & option as wired controller)
- ✓ Hospitals & Controls (Enterprise web app & option as wired controller)

FEATURES	
Power	5V Adapter OR 24/12V Hardwired
Installation	Wall Mount or Table Stand
Display Interface (On-Device, Local Control)	Power On / Off, Temperature Up/Down AC Modes (Cool, Heat, Dry, Fan, Auto) Room Temperature, Room Humidity, Set Point Temperature Fan Speed, Swing Position, Wi-Fi Signal Strength
Feature Set	Easy to configure; automatic detection of remote control Weekly Scheduling iOS, Android, Web, Alexa or Google Home compatible Location Based Controls - Geo-fencing Comfy Mode (Temperature or Humidity) Temperature Range Control Live AC Air Filter Status Usage History, Complete Action Timeline Turbo Mode for instant cooling (Consult your AC's remote user manual) Freeze Protection (FP) Mode (Consult your AC's remote user manual)
Dimensions	110 x 110 x 25.5 mm (L x W x H) max
Warranty	One Year Replacement

Compressor Oils

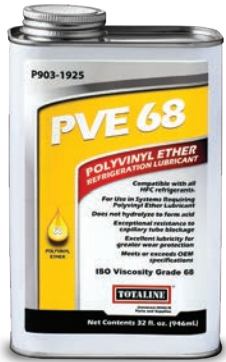

Polyolvinyl Ether Refrigeration Oil (PVE)

Totaline PVE is a new generation polyvinyl ether compressor lubricant for use with HFC refrigerants.

- Inherently resistant to Hydrolysis which provides superiority over polyolesters (POE)
- Use in systems requiring polyvinyl ether lubricant

Part Number	Size	Description	Replaces
P903-19251	Quart (946 ml)	PVE 68FVC	68D



Toshiba Oil

Lubrication oil base oil, lubrication oil additives

Part Number
PP23BZ071



Replacement Components

Carrier

Replacement Components • © Carrier Corporation 2022
Printed in the U.S.A. • Edition Date: 12/2022 Rev B • Lit. No.: 570-128

For promotional information visit www.rchvacparts.com
and for technical information visit www.hvacpartners.com