

**186CNV / 284ANV
Evolution™ Extreme
Variable Speed Air conditioner and Heat Pump
2 to 5 Nominal Tons**



Service Manual

Table of contents

	PAGE NO.		PAGE NO.
UNIT IDENTIFICATION	2	Defrost Mode	9
SAFETY CONSIDERATIONS	2	Defrost Interval.	10
General information	2	Defrost Process.	10
ELECTRICAL	3	PCM Indicators and Display Operation.	10
Aluminum Wire	3	Status Light	10
ELECTRICAL SYSTEM OVERVIEW	3	Comm Light	10
Terminal Block	3	VFD Comm Light.	10
Transformer	3	Matrix Display	10
Compressor / Fan Sub-System	3	Reprogrammability.	10
Variable Frequency Drive (VFD).	5	VFD LEDs	11
VFD Filter Board	5	Table 2 – VFD LED Indicator Functions	11
Reactors	5	TROUBLESHOOTING	12
High Pressure Switch (HPS).	5	TROUBLESHOOTING CONTROL FEATURES	12
Compressor Brushless Permanent Magnet Motor (BPM)	5	SYSTEM DIAGNOSTICS	12
VFD + Compressor BPM	5	Table 3 – Model Plug Information.	13
Fan Brushless Permanent Magnet Motor (BPM)	5	COMPONENT DIAGNOSTICS.	13
VFD + Fan BPM.	5	Table 4 – Variable Speed Compressor Resistances (ohm) (winding resistance at 68°F /20°C)	14
Crankcase Heater	5	Table 5 – DC Voltage and PWM Measurement	14
CONTROL SUB-SYSTEM.	5	Table 6 – Thermistor Resistance (k-ohms) vs. Temperature.	14
Primary Control Module (PCM).	5	DIAGNOSTIC CODES AND TROUBLESHOOTING	17
Control Connection (Communicating and Non-Communicating).	6	Table 7 – Fault Code Table	26
Communicating Evolution Control.	6	REFRIGERATION SYSTEM	35
Non-Communicating Control	6	Refrigerant	35
Table 1 – DIP Swtich Settings.	6	Compressor Oil	35
PCM Indicators and Matrix Display.	6	Servicing Systems on Roofs With Synthetic Materials	35
Model Plug	8	Synthetic Roof Precautionary Procedure	35
Thermistors	8	Brazing.	35
Pressure Sensors	8	Service Valves and Pumpdown	35
VFD Control Connection.	8	Pumpdown & Evacuation.	36
Pressure Equalization Valve (PEV)	8	Pump Down	36
Reversing Valve (RVS)	8	Evacuation and Recovery of Refrigerant from 284ANV	36
Heating Electronic Expansion Valve (EXV-H)	8	Reversing Valve (284ANV)	36
Bluetooth® Module	8	Liquid Line Filter Drier	37
Accessory Control Components.	8	Install Liquid-line Filter Drier Indoor.	37
Utility Curtailment	8	Suction Line Filter Drier	37
Liquid Line Solenoid Valve (LLS).	8	Thermostatic Expansion Valve (TXV)	37
CONTROL FEATURES AND OPERATION.	9	TXV Operation.	38
Equipment Configuration (Model Plug)	9	Accumulator.	38
Performance Mode.	9	Vapor Injection Operation (5 Ton Models).	38
Compressor Operation	9	Vapor Injection Electronic Exp. Valve (EXV VI) (5 Ton Models)	39
Compressor Protect Delay	9	REFRIGERATION SYSTEM REPAIR.	39
Starting	9	Leak Detection.	39
Running.	9	Coil Removal	39
Compressor Reliability Protection	9		
Sump Heat.	9		
Fan Operation	9		
Intermittent Low Fan Speed	9		
Fan Operating Exceptions.	9		
Cooling Control	9		
Heating Control.	9		
Super Heat Control	9		

UNIT IDENTIFICATION

The unit is identified using a 16 digit model number structure. It is recommended providing the complete 16 digit model number when ordering replacement parts to insure receiving the correct parts.

Model Number Nomenclature

1	2	3	4	5	6	7	8	9	10	11	12	13	14	15	16
N	N	N	A	A/N	N	N	N	N	A/N	A/N	N	A	A	A	A
1	8	6	C	N	V	0	3	6	0	0	0	F	A	A	A
Product Family	Tier	SEER	Major Series	Voltage	Variations	Cooling Capacity		Open	Open	Open	Parts Id	Minor Series	Minor Series	Open	
1 = AC 2 = HP	8=Evolution Series	4=24 SEER (HP) 6=26 SEER (AC)	Puron	N=208-230-1	V=Variable Speed	1,000 Nominal Btuh		0=Not Defined	0=Not Defined	0=Not Defined	E=VS Scroll F=VS Rotary	A=Original Series	A=Original Series	0=Not Defined	

SERIAL NUMBER NOMENCLATURE

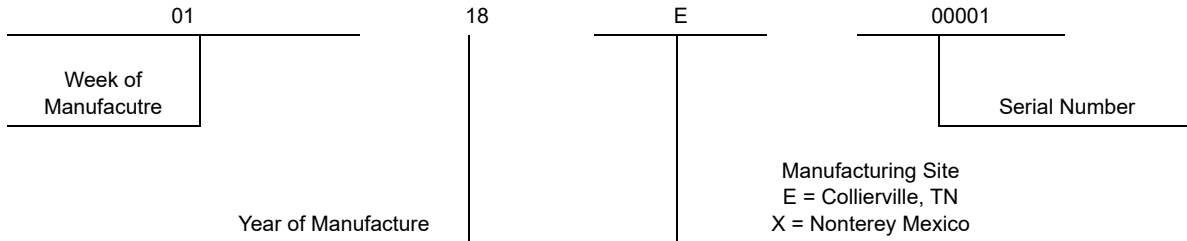

SAFETY CONSIDERATIONS

Installation, service, and repair of these units should be attempted only by trained service technicians familiar with standard service instruction and training material.

All equipment should be installed in accordance with accepted practices and unit Installation Instructions, and in compliance with all national and local codes. Power should be turned off when servicing or repairing electrical components. Extreme caution should be observed when troubleshooting electrical components with power on. Observe all warning notices posted on equipment and in instructions or manuals.

WARNING

ELECTRICAL SHOCK HAZARD

Failure to follow this warning could result in personal injury or death. Before installing, modifying, or servicing system, main electrical disconnect switch must be in the OFF position. There may be more than 1 disconnect switch. Lock out and tag switch with a suitable warning label.

WARNING

ELECTRICAL HAZARD - HIGH VOLTAGE!

Failure to follow this warning could result in personal injury or death. Electrical components may hold charge. DO NOT remove control box cover for 2 minutes after power has been removed from unit. PRIOR TO TOUCHING ELECTRICAL COMPONENTS: Verify less than zero (0) vdc voltage at VFD connections shown on cover.

CAUTION

CUT HAZARD

Failure to follow this caution may result in personal injury. Sheet metal parts may have sharp edges or burrs. Use care and wear appropriate protective clothing and gloves when handling parts.

WARNING

UNIT OPERATION AND SAFETY HAZARD

Failure to follow this warning could result in personal injury or equipment damage. Puron® (R-410A) systems operate at higher pressures than standard R-22 systems. Do not use R-22 service equipment or components on Puron equipment. Ensure service equipment is rated for Puron®.

Refrigeration systems contain refrigerant under pressure. Extreme caution should be observed when handling refrigerants. Wear safety glasses and gloves to prevent personal injury. During normal system operations, some components are hot and can cause burns. Rotating fan blades can cause personal injury. Appropriate safety considerations are posted throughout this manual where potentially dangerous techniques are addressed.

If you do not understand any of the warnings, contact your product distributor for better interpretation of the warnings.

General information

The Evolution Extreme heat pump and air conditioner features the latest variable speed technology. The heart of the system is the Samsung high side rotary or scroll variable speed compressor powered through the use of the Samsung variable frequency drive (VFD) control. By combining the Primary Control Module (PCM), an ECM outdoor fan, Samsung VFD, Samsung variable speed compressor and the Evolution Extreme outdoor cabinet, the HP unit achieves a Seasonal Energy Efficiency Ratio (SEER) of up to 24 and up to 13 Heating Seasonal Performance Factor (HSPF) and the AC achieves up to 26 SEER.

To ensure all of the above technology provides the ultimate in comfort, it is combined with either a fan coil or Variable Speed Gas furnace controlled with a two wire communication Evolution wall control.

ELECTRICAL

! WARNING

ELECTRICAL SHOCK HAZARD

Failure to follow this warning could result in personal injury or death. Exercise extreme caution when working on any electrical components. Shut off all power to system prior to troubleshooting. Some troubleshooting techniques require power to remain on. In these instances, exercise extreme caution to avoid danger of electrical shock. ONLY TRAINED SERVICE PERSONNEL SHOULD PERFORM ELECTRICAL TROUBLESHOOTING.

Aluminum Wire

! CAUTION

UNIT OPERATION AND SAFETY HAZARD

Failure to follow this caution may result in equipment damage or improper operation.

Aluminum wire may be used in the branch circuit (such as the circuit between the main and unit disconnect), but only copper wire may be used between the unit disconnect and the unit.

Whenever aluminum wire is used in branch circuit wiring with this unit, adhere to the following recommendations.

Connections must be made in accordance with the National Electrical Code (NEC), using connectors approved for aluminum wire. The connectors must be UL approved (marked Al/Cu with the UL symbol) for the application and wire size. The wire size selected must have a current capacity not less than that of the copper wire specified, and must not create a voltage drop between service panel and unit in excess of 2 of unit rated voltage. To prepare wire before installing connector, all aluminum wire must be “brush-scratched” and coated with a corrosion inhibitor such as Pentrox A. When it is suspected that connection will be exposed to moisture, it is very important to cover entire connection completely to prevent an electrochemical action that will cause connection to fail very quickly. Do not reduce effective size of wire, such as cutting off strands so that wire will fit a connector. Proper size connectors should be used. Check all factory and field electrical connections for tightness. This should also be done after unit has reached operating temperatures, especially if aluminum conductors are used.

ELECTRICAL SYSTEM OVERVIEW

The electrical system consists of four main primary components and sub-systems as listed below and shown in Fig. 1

- Terminal Block
- Transformer
- Compressor and Fan Sub-System
- Control Sub-System

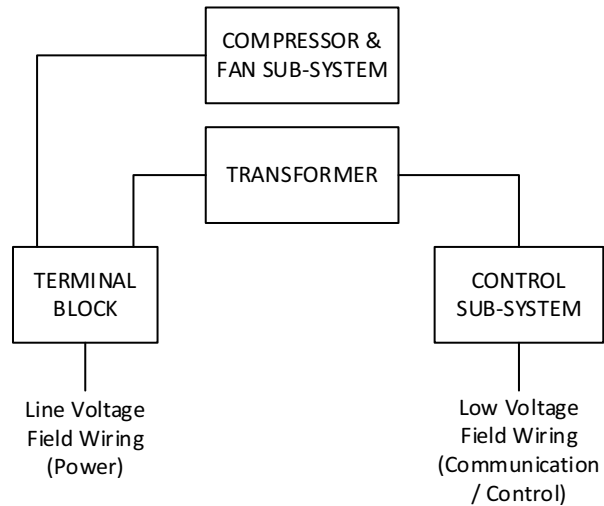

Fig. 1 – ELECTRICAL SYSTEM OVERVIEW

A200232

Terminal Block

The terminal block provides the connection point for high voltage field power wiring

Transformer

! CAUTION

Equipment Damage Hazard

Failure to follow this caution may result in equipment damage or improper operation.

Do not connect the equipment 24VAC supply (Rc) to the indoor equipment 24VAC supply (Rh).

IMPORTANT: The 24VAC power (Rc) in the PCM comes from the transformer in the equipment. The phase of this transformer connection is not controlled relative to the phase of the power provided by the transformer in the indoor equipment (Rh). Wiring requirements in this manual do not connect Rc and Rh together. For any non-standard wiring, care should be taken to make sure that Rc and Rh are not connected together. Doing so may result in destroying one or both of the transformers in this and the indoor equipment.

The transformer converts line voltage power to low voltage power required by the control system. The transformer also provides isolation between the line voltage and low voltage systems.

Compressor / Fan Sub-System

The compressor / fan subsystem consists of the following components:

- Variable speed compressor
- Variable speed fan
- Variable Frequency Drive (VFD) sub-system for driving the compressor and fan

The VFD sub-system consists of several components that are shown conceptually in Fig. 2 with detailed wiring shown in Fig. 3. The function of each component is described in further detail in the following section.

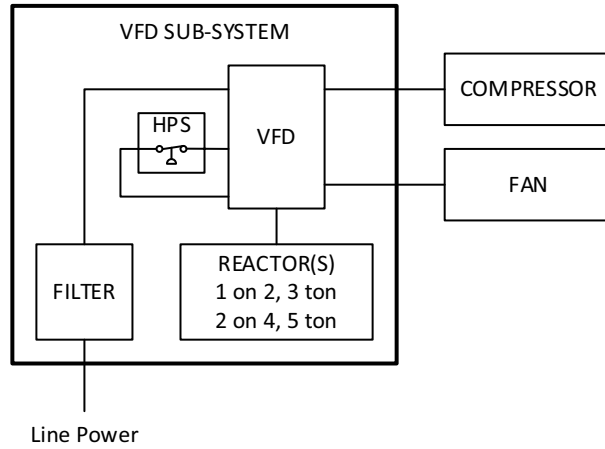

Fig. 2 – Compressor / Fan Sub-System Diagram

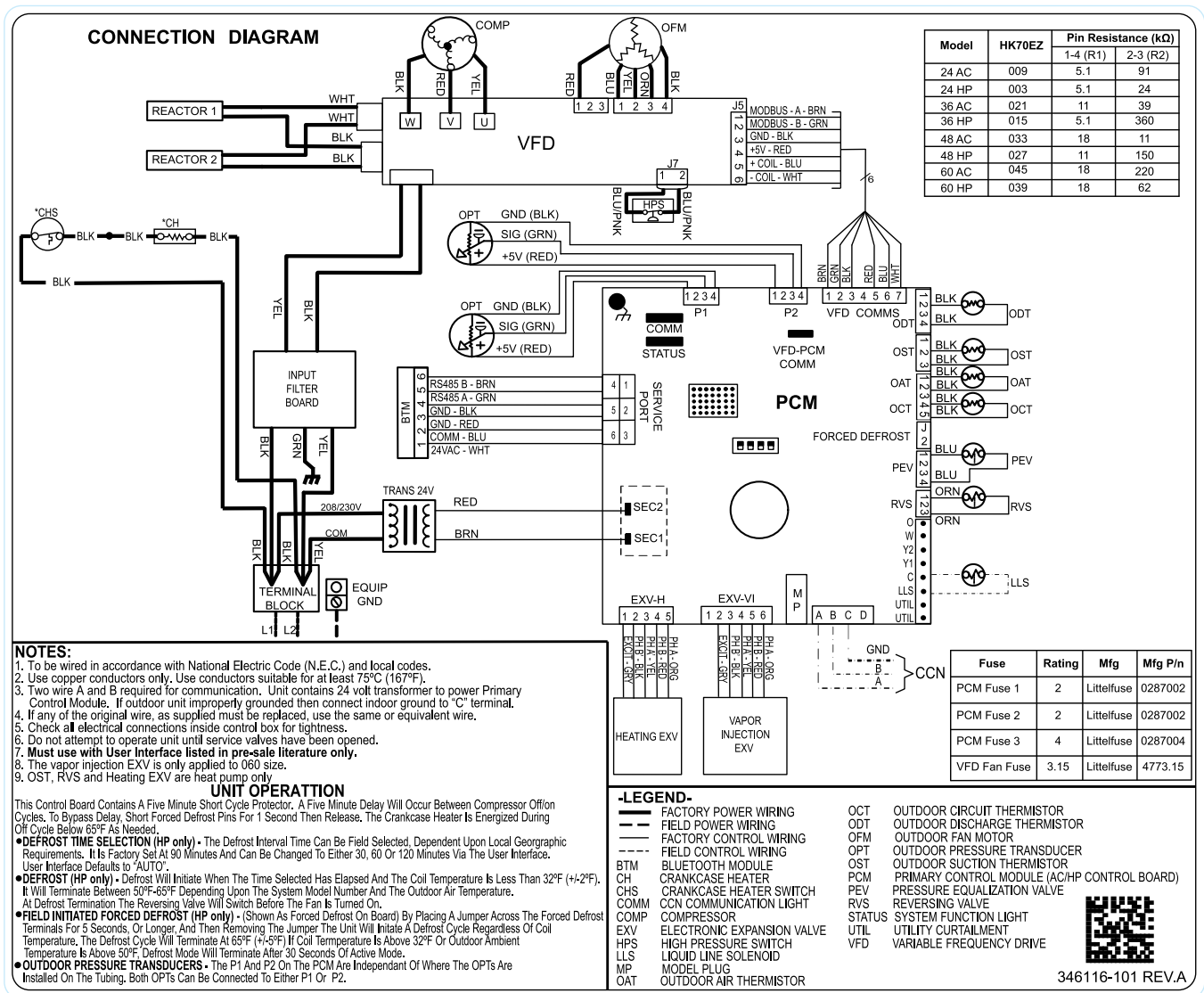

Fig. 3 – Wiring Diagram — 186CNV / 284ANV Model sizes 2 - 5 tons, 208/230-1

Variable Frequency Drive (VFD)

The VFD converts single phase 60 Hz line power into a variable frequency, variable voltage, 3-phase output to drive the compressor at the speed requested by the control system. This function is performed by first converting the incoming line power to an intermediate high voltage DC supply. The high voltage DC supply is then converted to a 3-phase output by a variable frequency inverter for driving the compressor. The VFD also provides high voltage DC supply power to the fan motor.

The VFD contains numerous protection modes for maximizing reliability and preventing faults in wiring or the compressor and fan components from causing failures within the VFD.

VFD Filter Board

The VFD filter board blocks electrical noise generated within the VFD from back-feeding onto the line power feed to the equipment. It contains non-replaceable fuses which will protect the VFD in the event of a severe power surge condition.

Reactors

Reactors are part of the VFD incoming power conversion circuit. The reactors enable boosting of incoming line power when necessary and also provide power factor correction.

High Pressure Switch (HPS)

The HPS is a normally closed switch connected to VFD control circuitry. The HPS opens when the compressor discharge pressure reaches 670 psig. When the switch opens, a control input to the VFD is disabled and causes the compressor and fan to shut down. When compressor discharge pressure decreases to 470 psig, the switch closes and allows equipment operation to resume.

Compressor Brushless Permanent Magnet Motor (BPM)

The compressor uses a highly efficient, brushless permanent magnet motor. Motor speed is synchronized to, and controlled by the frequency of the drive provided by the VFD.

VFD + Compressor BPM

Compressor runs at variable speeds controlled by the VFD.

The VFD controls acceleration and deceleration speeds of the compressor. Speed changes are typically limited to 60 rpm per second.

The VFD will automatically limit compressor speed if compressor load current reaches operating limits.

Fan Brushless Permanent Magnet Motor (BPM)

The fan uses a highly efficient, brushless permanent magnet motor. Motor speed is synchronized to, and controlled by an on-board variable frequency inverter (VFI) integrated with the motor and located within the motor housing. The VFI uses the high voltage DC supply provided by the VFD to drive the fan, and a low voltage control signal from the VFD to determine fan speed. The fan provides a feedback signal to the VFD indicating fan speed.

VFD + Fan BPM

The fan runs at a variable speed over a range of 200 rpm to 800 rpm depending on air movement requirements.

The fan on-board VFI will automatically limit fan speed if fan load current reaches operating limits.

Crankcase Heater

Some equipment has a crankcase heater band installed around the compressor case near the bottom of the compressor. The heater is energized when the outdoor ambient temperature drops below 65°F and is de-energized when the outdoor ambient temperature goes above 85°F. Heating the compressor prevents liquid refrigerant from accumulating in the compressor by ensuring that the compressor is not the coldest part of the system. The crankcase heater operates independently of indoor equipment and System Control and functions as needed any time the outdoor equipment is powered.

Some equipment has an internal stator heating function without a crankcase heater. The compressor windings will occasionally be energized during the OFF cycle to start the stator heat operation, thus maintaining a sump temperature that is essential for compressor reliability. The compressor will not run during this process. The equipment that utilizes the stator heating function does not include a crankcase heater, have PCM SW version 5.0 or higher, and utilizes new VFD hardware and software. The VFD part numbers HR46VP002, HR46VQ002, and HR46VR002 include the stator heating function.

With either crankcase heating or stator heating the system must be powered on for a minimum of 24 hours prior to starting the system to ensure that liquid refrigerant is not present in the compressor.

CONTROL SUB-SYSTEM

The control sub-system provides the connection point for low voltage field communication and control wiring. The control sub-system controls all operation of the equipment.

Primary Control Module (PCM)

The PCM is the heart of the equipment control system. The PCM is the connection point for all control components except for the high pressure switch and crankcase heater (when present).

The PCM receives equipment control requests from a communicating Evolution Control or from a non-communicating control (traditional thermostat) in an emergency operating mode.

The PCM receives signals from numerous sensors, including:

- 4 thermistors: OAT, OCT, OST, PDT
- 2 pressure transducers: SPT, DPT.

The PCM controls numerous actuators and signals, including:

- 3 control solenoids: PEV, RVS and LLS
- 2 electronic expansion valves: EXV-H, EXV-VI
- VFD Control Interface
- Emergency Mode 24VAC Control Signals: O and W

The PCM performs numerous diagnostics and supports 120 diagnostic codes. Each of these codes is described in the Troubleshooting section. Diagnostics cover the following:

- Line voltage and communication
- Equipment configuration (model plug, etc.)
- Compressor and fan operation
- Sensors
- Actuators

The PCM contains indicators and displays to provide operating status and conditions. The PCM also supports communication with the Bryant Service Tech App through the Bluetooth Module which provides detailed diagnostic information and reprogramming capability.

Control Connection (Communicating and Non-Communicating)

The primary system control interface for the PCM is the communicating Evolution Control. The PCM also supports traditional 24VAC discrete control signals in an emergency mode of operation when a communicating control is not available.

Communicating Evolution Control

The communicating Evolution Control uses a 2-wire connection as shown in Fig. 3 and Fig. 4. An optional 3rd wire can be added for a ground connection. The third wire is recommended for long communication runs or if there are problems encountered with consistent communication using a 2-wire setup. The Comm light indicates whether communication is being received from a system control.

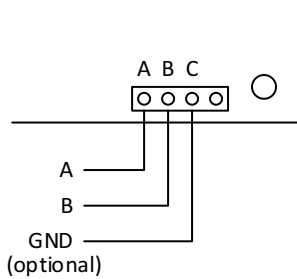

Fig. 4 – Evolution Control Connection

A200239

Non-Communicating Control

The non-communicating control connections are shown in Fig. 5. Specific connections depend on system configuration. Note that O and W are driven during Defrost for heat pump models.

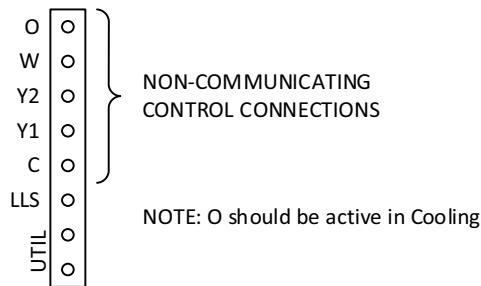

Fig. 5 – Non-Communicating Control Connection

A200240

In non-communicating mode, the Performance Mode and Defrost Interval are set using DIP switches. Switch assignments are shown in Fig. 6. Switch settings are shown in the Table 1

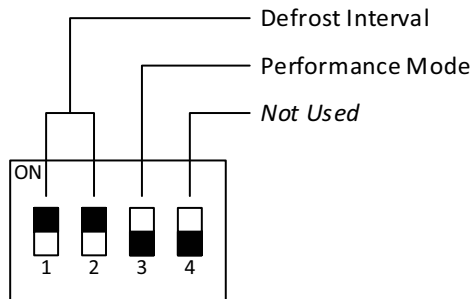

Fig. 6 – Non-Communicating DIP Switch Assignment

A200241

Table 1 – DIP Switch Settings

Switch 1	Switch 2	Defrost Interval
Up	Up	Auto
Up	Down	30 minutes
Down	Up	60 minutes
Down	Down	90 minutes

Switch 3	Performance Mode
Up	Efficiency
Down	Comfort

IMPORTANT: The R (Rc) signal on the PCM comes from the transformer in the equipment. The phase of this transformer connection is not controlled relative to the phase of the transformer in the indoor equipment (Rh). Wiring requirements in this manual do not connect Rc and Rh together. For any non-standard wiring, care should be taken to make sure that Rc and Rh are not connected together. Doing so may result in destroying one or both of the transformers in this and the internal equipment.

PCM Indicators and Matrix Display

The PCM contains three indicator lights (LEDs) and a dot matrix display. Indicator and display location is shown in Fig. 7. The indicators are described briefly below. Indicator operation and interpretation is described in the Control Features section.

Status Light

The status light is a single color amber LED that indicates equipment operating status and diagnostic conditions.

Comm Light

The Comm light is a single color green LED that indicates the communication state and system control state of the equipment.

VFD Comm Light

The VFD Comm Light is a bi-color red / green LED that indicates the communication with the VFD.

Matrix Display

The matrix display is a 5x7 dot matrix for displaying messages and diagnostic information.

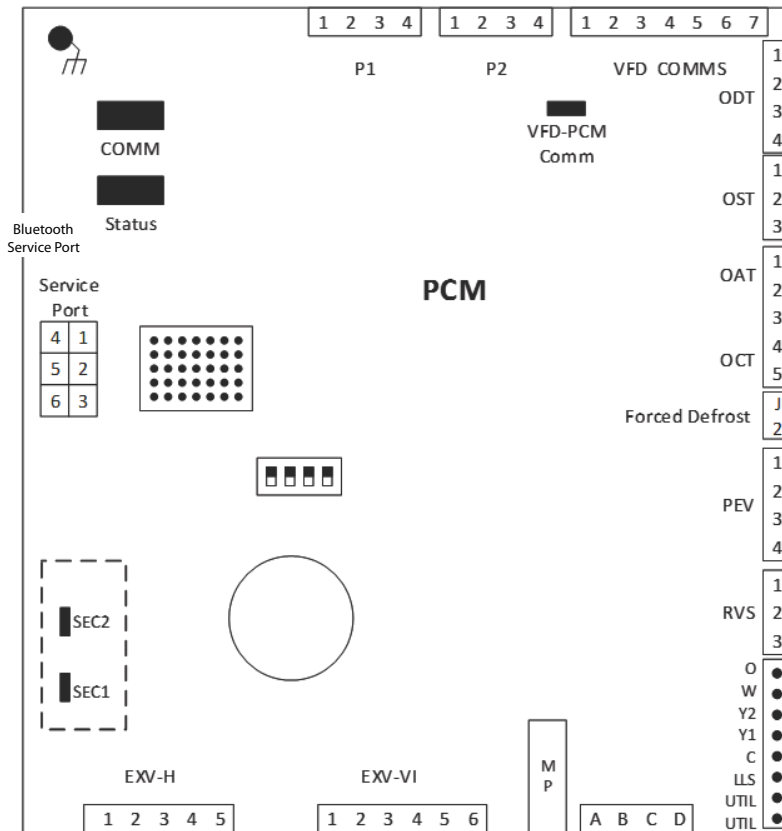

A200049

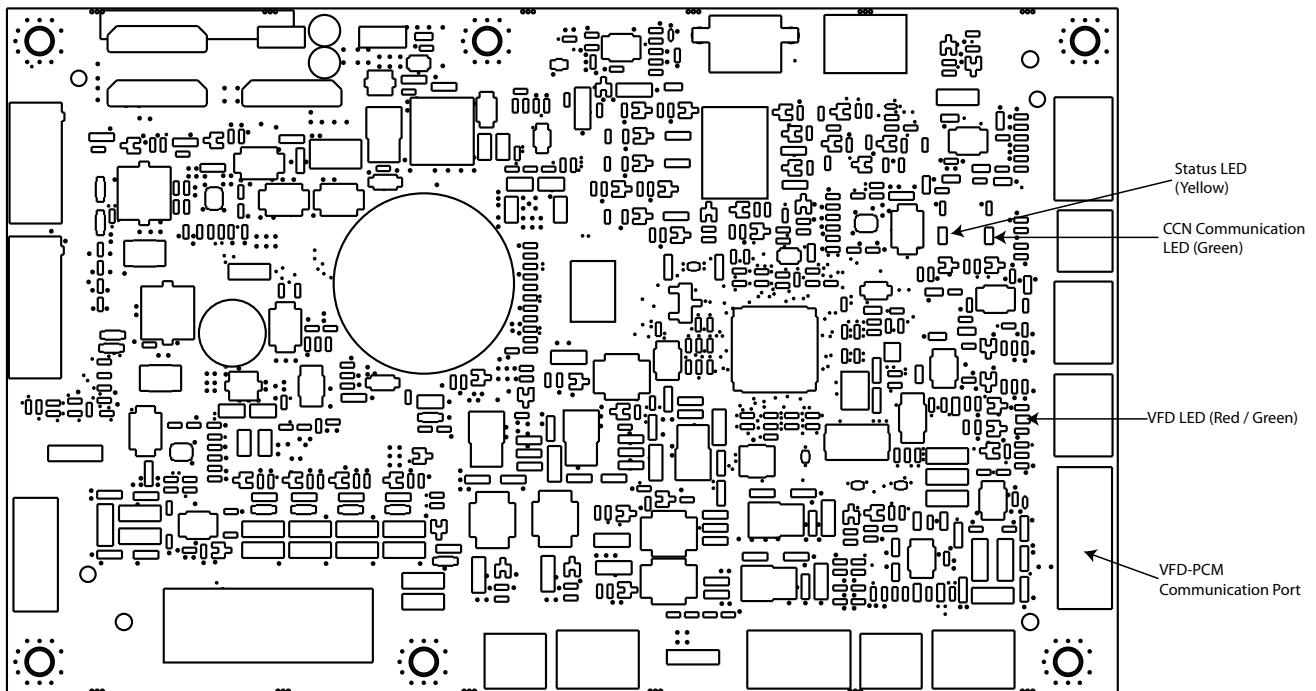

Fig. 7 – PCM Control Board

A200044

Model Plug

Each control board contains a model plug. The model plug is used to identify the type and size of equipment to the PCM.

Thermistors

The equipment contains 4 thermistors as described below.

- Outdoor Ambient Temperature (OAT)
- Outdoor Coil Temperature (OCT)
- Outdoor Suction Temperature (OST)
- Outdoor Discharge Temperature (ODT)

Pressure Sensors

The equipment contains two pressure transducers:

- Suction Pressure Transducer (SPT)
- Discharge Pressure Transducer (DPT)

The two transducers are identical parts installed on the suction inlet to the compressor and discharge outlet of the compressor respectively. The transducers have a sensing range of 0 to 620 psig. The connection points to the PCM are labeled P1 and P2. These two connection points are identical. Either pressure transducer can be connected to either input. The software in the PCM detects which transducer is connected to which input and assigns the signals accordingly.

VFD Control Connection

The VFD Control Connection consists of 6 wires as shown in Fig. 3. Two of the wires provide a control enable signal. Four of the wires are used for communication between the PCM and the VFD.

Pressure Equalization Valve (PEV)

The PEV is actuated by a 24VAC control solenoid. The PCM controls the PEV by providing a drive signal to the PEV control solenoid. The PEV is used to reduce the pressure differential between the compressor suction and discharge ports.

Reversing Valve (RVS)

(284ANV Only)

The RVS is actuated by a 24VAC control solenoid. The PCM controls the RVS by providing a drive signal to the RVS control solenoid. The RVS is used to reverse refrigerant flow between the Cooling and Heating modes in a heat pump. AC equipment does not contain an RVS. The RVS will be energized during Cooling operation and during the Defrost mode in Heating operation.

Heating Electronic Expansion Valve (EXV-H)

(284ANV Only)

The EXV-H is an electronically controlled needle valve for regulating refrigerant flow during heating operation. The EXV-H is driven by a 12VDC, 2-phase, uni-polar stepper motor. The EXV-H has a 475 step range between fully closed and fully open. The PCM drives the EXV at a rate of 77 steps per second. The PCM initializes the EXV-H to the closed position when power is applied to the equipment. This process takes approximately 7 seconds.

When the compressor is not running, the EXV-H is closed. When operating in Cooling or in Defrost mode of heating, the EXV-H will be fully open. When operating in Heating mode, the EXV-H is actively controlled to maintain suction super heat to the control target value.

Bluetooth® Module

The Bluetooth Module is a wireless service communication device allowing the equipment to communicate with the Bryant Service Tech App. The Bryant Service Tech App can be used to retrieve diagnostic information, equipment operating history, and reprogram the PCM or the VFD.

Accessory Control Components

Utility Curtailment

The Utility Curtailment feature is controlled by an optional external switch or relay wired to the two UTIL connections on the PCM as shown in Fig. 8. The UTIL connections are wired to the normally open switch contacts. This input allows a power utility device to interrupt equipment operation during peak load periods. When the utility sends a signal to shut the system down, the equipment sends a curtailment indication to the Evolution Control. The Evolution Control will command an equipment shutdown and may display a curtailment notification. See Evolution Control installation or service instructions for more detail.

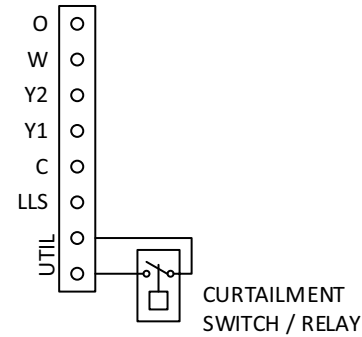

Fig. 8 – Curtailment Switch/Relay Connection

A200242

Liquid Line Solenoid Valve (LLS)

The LLS is an optional external normally closed valve that is installed in systems with large vertical distance offsets between the indoor equipment and outdoor equipment. The outdoor equipment will energize the valve when the compressor is running, and de-energize the valve when the compressor is not running to prevent gravity-induced migration of liquid refrigerant. The LLS is wired between the C and LLS contacts as shown in Fig. 9.

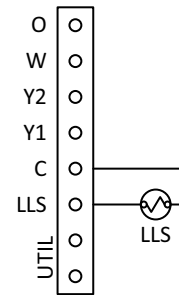

Fig. 9 – Curtailment Switch / Relay Connection (LLS)

A200243

CONTROL FEATURES AND OPERATION

Equipment Configuration (Model Plug)

The PCM detects the model plug value at power-up and configures operation of the equipment to the model identification specified by the model plug for the remainder of the power cycle. Model plug diagnostics will occur while the equipment is operating, but changes to a model plug will not affect equipment operation until power is cycled.

The PCM remembers the most recent valid model plug detected at power-up. If a model plug is lost or missing during equipment operation, the PCM will continue to operate the equipment based on the most recent valid model plug detected at power-up. Model plug memory is preserved across power cycles, so if a model plug becomes missing, proper equipment operation will continue even if power to the equipment is lost and then restored.

An installed model plug at power-up takes precedence over a model plug value stored in memory. If a new valid model plug value is detected at power-up, the model plug memory will be updated to that new value.

Performance Mode

The PCM supports equipment operation in two performance modes: Efficiency and Comfort. Efficiency mode provides maximum possible operating efficiency. Comfort mode modifies operation to provide optimal comfort to the home.

Compressor Operation

Compressor Protect Delay

The compressor is inhibited from running within 5 minutes of power being applied to the equipment or within 5 minutes of previous operation. The Compressor Protect Delay can be overridden as described in Overrides in the Troubleshooting section.

Starting

The compressor will not start if the differential pressure between suction and discharge is greater than 100 psi. When a capacity demand is received, the outdoor fan begins operating first. Once the fan begins operating, the compressor is started. The compressor will ramp to 2,700 rpm and dwell at that speed until the required amount of discharge super heat is developed.

Running

Once start-up super heat is reached, the compressor will ramp up or down to the appropriate continuous operating speed. Compressor operating speed depends on the capacity being requested by the Evolution Control, the Operating Mode (Cooling vs. Heating), the outdoor air temperature, and the Performance Mode setting.

Compressor Reliability Protection

During operation, the PCM monitors the operating point of the compressor relative to the reliability operating envelope. If operation attempts to exceed a reliability limit, system operation is modified to bring operation back within the envelope. Examples of modified operation include increasing fan speed and reducing compressor speed.

During extreme operating conditions, operation may not be able to be maintained within the reliability envelope. If this occurs, the PCM will shut down the system and set a diagnostic code indicating the type of limit being exceeded. Extreme operating conditions are usually partially or completely created by non-ideal operating conditions that can be corrected by equipment service. Examples of such conditions include blocked or partially blocked coil on the indoor or outdoor equipment, and under-charged or over-charged systems.

Sump Heat

When the compressor is not running, the compressor sump may need to be heated to prevent liquid refrigerant from collecting in the sump. This condition is most likely with reduced outdoor temperatures.

Some systems use an external Crankcase Heater installed around the bottom portion of the compressor. Other systems may use a stator heating function where the VFD flows a DC current through the motor windings. This stator current heats the motor. That heat is transferred to the compressor shell and heats the compressor sump.

Fan Operation

The fan generally runs when the compressor is running. When the equipment begins to operate, the fan will start first, then the compressor will start. Fan speed is adjusted based on the Operating Mode (Cooling vs. Heating), the outdoor air temperature and compressor speed.

Intermittent Low Fan Speed

In some operating conditions such as Low Ambient Cooling, airflow requirements are below the minimum fan speed. In these cases, the fan will operate intermittently. The fan on/off cycle during this operation is approximately 40 seconds.

Fan Operating Exceptions

There are some operating conditions where the fan will operate independently of the compressor. During the defrost cycle, the fan will not operate while the compressor is running. It is possible for the equipment to shut down during a defrost cycle. On the next operating cycle, the equipment will resume in defrost mode. In this case, the fan will run briefly at power-up and then shut down while the previously interrupted defrost cycle completes.

The fan may intermittently shut down during Low Ambient Cooling operation, especially at colder temperatures and if the wind is blowing during operation.

If the compressor is shut down due to a discharge pressure limit or VFD or compressor high discharge temperature limit, the fan will continue to run for a period of time after the compressor shuts down in order to alleviate the excessive temperature or pressure condition.

Cooling Control

Cooling mode will operate at any outdoor ambient temperature of 55°F (12.78°C) or higher. There is no upper limit of outdoor ambient temperature operation. Full cooling capacity is available up to at least 125°F (51.67°C) for properly installed and maintained equipment. If Low Ambient Cooling is enabled on the Evolution Control, the cooling mode will operate down to 0°F (-17.78°C).

Heating Control

(284ANV Only)

Heating mode will operate up to an outdoor ambient temperature of 75°F (23.9°C). Heating mode will start down to 0°F (-17.78°C). If the equipment is already operating when ambient temperature drops below 0°F (-17.78°C), the equipment will continue to operate until some limit is reached. Heating capability should be available down to -10°F (-23.3°C) or lower for properly installed and maintained equipment.

Super Heat Control

Super heat control is provided by the EXV-H. The PCM continuously adjusts the EXV-H to keep suction super heat operating at the target control value.

Defrost Mode

(284ANV Only)

Defrost mode is part of Heating Control. Because the outdoor coil operates at a temperature below ambient, it has the potential for condensing moisture from the air. When the coil temperature is at freezing conditions, that condensation will occur as frost. As frost builds on the coil, the frost acts as an insulator and reduces the heating capacity of the coil. Periodic defrost is required to remove frost and restore heating capacity.

Defrost Interval

The Defrost Interval is the amount of time that heating operation can occur in frost-accumulating conditions before a defrost cycle is required to clear the frost. Frost accumulating conditions are defined as operation with a coil temperature below 35°F. The Defrost Interval can be set to a fixed value, or it can be determined automatically by the control. Automatic operation is recommended for most systems.

The Defrost Interval is set in the Evolution Control and communicated to the outdoor equipment. In non-communicating systems, the Defrost Interval is set with DIP switches on the PCM. Available Defrost Interval settings are:

- 30 minutes
- 60 minutes
- 90 minutes
- 120 minutes (not available for non-communicating systems)
- Auto

Auto mode is recommended for all systems unless unusual application conditions indicate a fixed setting should be used. Auto mode will adjust the defrost interval dynamically and provide optimum system performance.

Auto mode adjusts the defrost interval time based on the previous defrost cycle time as shown in the following table.

Previous Defrost Duration	Next Defrost Interval
Less than 3 minutes	120 minutes
Greater than 3 but less than 5 minutes	90 minutes
Greater than 5 but less than 7 minutes	60 minutes
Greater than 7 minutes	30 minutes

Defrost Process

The defrost process begins when the defrost interval time is reached under frost-accumulating conditions. The defrost process ends when the coil reaches a temperature threshold - usually 60°F. Defrost may also terminate as a result of a time limit - usually 10 minutes. If Defrost is forced via the Forced Defrost input, defrost will be initiated regardless of frost accumulation time or outdoor temperature. A forced defrost will run at least 30 seconds, but may not run longer than 30 seconds if ambient temperature is well above freezing.

The Defrost Process proceeds as follows:

1. The compressor ramps to RVS transition speed
2. RVS is switched to defrost position (fan stays on)
3. Compressor ramps to defrost speed
4. Fan turns off when coil temperature increases to ambient temperature
5. Defrost completes when coil temperature reaches target or defrost timeout is reached.
6. The compressor ramps to RVS transition speed
7. RVS is switched to heating position (fan stays off)
8. Compressor ramps to heating speed
9. Fan turns on when coil temperature falls to ambient temperature

PCM Indicators and Display Operation

Operation and interpretation of each indicator and display is described.

Status Light

The operation modes and meaning for each mode of the status light is described in the table below for PCM SW versions 4.0 and above:

Mode	Meaning
Off	Power is removed from the PCM or there is a fundamental PCM fault.
On	Equipment is in standby with no diagnostic conditions preventing or limiting operation.
1 Slow Flash	Equipment is operating at low capacity (low stage in emergency mode).
2 Slow Flashes	Equipment is operating at high capacity (high stage in emergency mode).
Continuous Slow Flash	Equipment operation has been interrupted or is being limited.
Continuous Fast Flash	Equipment is in a lockout condition as a result of a diagnostic condition or is in Diagnostic Code Recall mode.

For PCM software versions older than 4.0, use the following table:

Mode	Meaning
Off	Equipment is in standby with no diagnostic conditions preventing or limiting operation.
On	N/A
1 Slow Flash	Equipment is operating at low capacity (low stage in emergency mode).
2 Slow Flashes	Equipment is operating at high capacity (high stage in emergency mode).
Flashing	A diagnostic code is present. The first digit of the fault base code can be determined by the short flashes and the second digit of the fault base code can be determined by the long flashes.
Continuous Fast Flash	N/A

Comm Light

The Comm light indicates communication received from a communicating control. If the Comm light is On, then communication has been received within the last 2 minutes and the equipment is operating in normal communication mode. If the Comm light is Off, then communication has not been received within the last 2 minutes, and the equipment is operating in emergency communicating mode.

VFD Comm Light

The VFD Comm light blinks every time there is a message received from the VFD. If a message is received with no errors, the light will flash green. If a message is received with an error, or if a message is expected and not received, the light will flash red. When the equipment is operating, communication is occurring very frequently. If communication is operating properly, the light will continuously flash while the equipment is operating.

Matrix Display

The matrix display will scroll a sequence of up to four active diagnostic codes. If more than four diagnostic codes are active at one time, then only the four highest priority codes are displayed. Codes are displayed in decreasing order of priority beginning with the highest priority code first. Scrolling repeats continuously with a brief pause between each sequence. If there are no codes active, then the display will remain blank. There are additional operating modes of the display associated with troubleshooting procedures described in the Troubleshooting section under Compressor Protection Delay Override and Diagnostic Code Recall.

Reprogrammability

The software in both the PCM and the VFD can be reprogrammed. Software updates are retrieved from the cloud by the Evolution Control and downloaded to the equipment. The equipment can operate normally during the download process. Once the homeowner or service tech approves the update, the equipment will shut down (if operating), update the software as necessary, and resume operation. The software update process usually takes no more than a few minutes.

The software can also be updated from the Bryant Service Tech App via the Bluetooth Module. This is the only software update method for equipment using non-communicating control systems.

VFD LEDs

The VFD is equipped with several LEDs that indicate different statuses.

WARNING

ELECTRICAL HAZARD - HIGH VOLTAGE!
 Failure to follow this warning could result in personal injury or death. Electrical components may hold charge. **DO NOT** remove control box cover for 2 minutes after power has been removed from unit.
PRIOR TO TOUCHING ELECTRICAL COMPONENTS:
 Verify less than zero (0) vdc voltage at VFD connections shown on cover.

Table 2 – VFD LED Indicator Functions

LED Identification	Color	Function
R1	Red	Used to indicate that high voltage is present in the DC capacitors. If this LED is lit then a DC voltage greater than 40V is present.
G1	Green	Blinks when the VFD receives a message from PCM.
G2	Green	On when VFD is in normal status. It is off when VFD is fault status.
G3	Green	On when the VFD microcontroller relay is closed. The signal of relay is controlled by PCM.
A1	Amber	On when 12V source is normal.
A2	Amber	On when the main relay is closed.

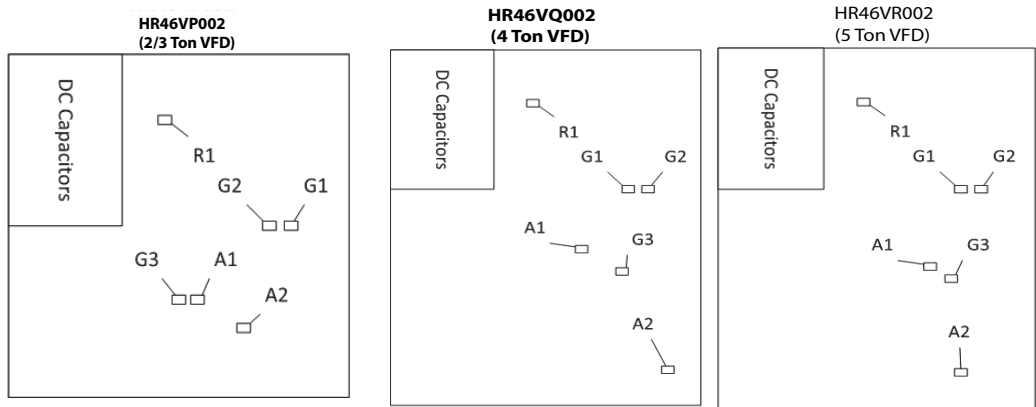

Fig. 10 – VFD LED Location for Each Tonnage

TROUBLESHOOTING

TROUBLESHOOTING CONTROL FEATURES

Diagnosics Display

Active diagnostics will be continuously displayed on the matrix display on the PCM. Active diagnostics can also be displayed on the system control (UI) screen. If the system control loses communication with the equipment after a diagnostic code is set by the PCM, the base code will be retained in the system control but the expansion code will show as "00", e.g. 38-18 will show as 38-00. The base code may be enough to troubleshoot the system, however, the complete diagnostic code can be retrieved from the equipment by using the service technician app or Diagnostic Code Recall mode at the PCM. Please refer to PCM Indicators and Display Operation in the Control Features and Operation section for further information.

Multi-Function Forced Defrost Input (J3)

The forced defrost pins are located near the right edge of the PCM slightly above center, between two connectors. The Forced Defrost input has the following functions:

- Forcing Defrost
- Overriding the Compressor Protect Delay
- Activating the Diagnostic Code Recall Function

These multiple functions are available at the PCM header only. The Forced Defrost function on the Evolution Control provides only the Defrost Forcing function. Each of these functions is described below.

Forced Defrost

A Forced Defrost event will begin when the Forced Defrost header pins are shorted for 5 seconds while the following conditions apply:

- The equipment is operating in Heating Mode (compressor is running)
- A defrost cycle is not already in progress

The defrost event will begin with a change in compressor speed followed by actuation of the reversing valve. For more information on the Defrost Process, refer to Defrost Mode under Control Features and Operation section.

Compressor Protect Delay Override

The Compressor Protect Delay will be overridden allowing immediate equipment start when the Forced Defrost header pins are shorted for 1 second while the equipment is not operating (compressor is off).

The override condition will be confirmed with the word **OVERRIDE** scrolled across the matrix display until the compressor starts. Note that the compressor will not attempt to start unless a demand is present, and until pressure equalization is complete (if necessary) and the fan has successfully started.

Diagnostic Code Recall

The Diagnostic Code Recall mode will be enabled if the Forced Defrost pins are shorted when power is applied to the equipment. It is not possible to enter Diagnostic Code Recall mode while power is applied to the equipment. The recommended procedure is to remove power from the equipment, apply a clip wire between the Forced Defrost header pins and then apply power to the equipment.

While in Diagnostic Code Recall mode, the Display Matrix will scroll the word **RECALL** followed by the most recent, highest priority diagnostic code if that code occurred with the last 240 hours of equipment operation. The display will repeat continuously while recall mode is active. No code will be displayed if the most recent, highest priority diagnostic code occurred more than 240 hours of equipment operating time before entering recall mode. No code will be displayed if there have never been any diagnostic codes active. If there is no code to display, then only the word **RECALL** will be scrolled across the display while the mode is active.

The equipment will not operate while the Diagnostic Code Recall mode is active.

The equipment will exit Diagnostic Code Recall mode when the short is removed from the Forced Defrost header pins, or 15 minutes after power is applied to the equipment if the short is still present. Upon exiting recall mode, the recall code display will stop, any active codes will begin to be displayed, and the equipment will resume normal operation.

SYSTEM DIAGNOSTICS

24VAC Power Distribution



CAUTION

EQUIPMENT DAMAGE HAZARD

Failure to follow this caution may result in equipment damage or improper operation.

Do not connect the equipment 24VAC supply (Rc) to the indoor equipment 24VAC supply (Rh).

IMPORTANT: The 24VAC power (Rc) in the PCM comes from the transformer in the equipment. The phase of this transformer connection is not controlled relative to the phase of the power provided by the transformer in the indoor equipment (Rh). Wiring requirements in this manual do not connect Rc and Rh together. For any non-standard wiring, care should be taken to make sure that Rc and Rh are not connected together. Doing so may result in destroying one or both of the transformers in this and the internal equipment.

The transformer in the equipment provides power to the PCM and numerous control components in the equipment. The power distribution and fuse connections for this power distribution are shown in [Fig. 11](#).

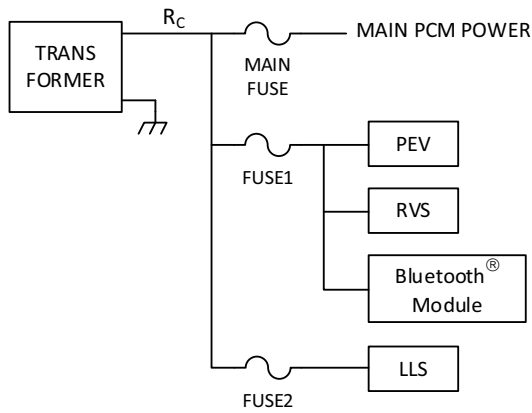

Fig. 11 – 24VAC Power Distribution Diagram

A200252

Communication

If communication with the Evolution Control is lost, this will be indicated by the Comm light being off. There is no diagnostic fault associated with this condition. When communication with the Evolution Control is lost, the equipment will default to the discrete control inputs for operation. Refer to Control Connection in the Control Sub-System section for further information.

Equipment Configuration (Model Plug)

CAUTION

EQUIPMENT DAMAGE HAZARD

Failure to follow this caution may result in equipment damage or improper operation.

Do not attempt to operate system with incorrect model plug as this could cause equipment damage.

Each control board contains a model plug. The model plug is used to identify the type and size of equipment to the control. The correct model plug must be installed for the system to operate properly (see Table 3). Refer to Equipment Configuration in the Control Features and Operation section for further information.

Table 3 – Model Plug Information

MODEL NUMBER	MODEL PLUG NUMBER	PIN RESISTANCE (K-ohms)	
		Pins 1-4	Pins 2-3
186CNV024	HK70EZ009	5.1K	91K
186CNV036	HK70EZ021	11K	39K
186CNV048	HK70EZ033	18K	11K
186CNV060	HK70EZ045	18K	220K
284ANV024	HK70EZ003	5.1K	24K
284ANV036	HK70EZ015	5.1K	360K
284ANV048	HK70EZ027	11K	150K
284ANV060	HK70EZ039	18K	62K

High Pressure Switch Protection

The outdoor unit is equipped with a high pressure switch. If the control senses the opening of a high pressure switch, it will respond as follows:

1. De-energize the VFD.
2. Display the appropriate fault code (See Table 7).
3. After discharge pressure drops below 425 PSIG, if there is a call for cooling or heating PCM and VFD will restart system.
4. High pressure switch trips do not escalate to a malfunction. Other system protections should reduce or stop unit operation before pressure switch opens.

5. Loose fitting connections or wire breaks will also simulate a high pressure switch trip if the discharge pressure is high. Otherwise, a loose fitting or wire break will simulate a VFD communication error.
6. Rapid increase of discharge pressure may not allow other system protections to take steps to reduce discharge pressure and may result in high pressure switch trip.

High Pressure Protection

The equipment monitors the discharge pressure relative to high pressure limits. High pressure limits are compressor speed and model dependent. If the control senses a high pressure, it will respond as follows:

- Increase outdoor fan speed and lower compressor speed to preempt a high pressure shutdown. Note: in cooling outdoor fan and compressor speeds are changed. In heating, suction superheat and compressor speeds are reduced.
- The control will attempt to compensate for exceeding high pressure limits. A shutdown will occur if the system is unable to bring pressure back below the desired limit. The control will shut the system down immediately if pressure exceeds 620 psig.
- If a high pressure shutdown occurs, a diagnostic code will be set to indicate the cause for shutdown.
- If high pressure shutdown occurs, the next operating cycle will operate at 25% less capacity. Each fault after that will reduce capacity by an additional 25%. Each hour of operation without a fault will increase the available capacity by 25%.
- If a high pressure fault occurs twice when system is operating at minimum capacity, the system will shut down with a 2 hour lockout.

In the event of a high pressure trip or high pressure lockout, check the refrigerant for an over charge. If the charge is found to be correct, check for outdoor coil blockage in cooling. In heating, check the indoor coil for blockage and indoor fan for proper operation.

Low Pressure Protection

The equipment monitors suction pressure relative to low pressure limits. Low pressure limits are compressor speed and model dependent. If the control senses a low pressure, it will respond as follows:

- Lower compressor speed and open EXV (heating only) to maintain suction pressure.
- The control will attempt to compensate for falling below the low pressure limit. A shutdown will occur if the system is unable to bring pressure back above the desired limit. The control will shut the system down immediately if pressure drops to 15 psig.
- If a low pressure shutdown occurs, a diagnostic code will be set to indicate the cause for shutdown.
- If a demand persists after the 5-minute compressor protection delay and the pressure has reached the operation level, then the system will resume operation.
- If a pressure drops below the instantaneous level four (4) times in 2 hours, then a 2 hour lockout will occur, and the system will display a malfunction code and communicate lockout status to the Wall Control.

In the event of a low pressure trip or low pressure lockout, check the refrigerant for an under charge. If the charge is found to be correct, check for low indoor airflow in cooling and the outdoor fan for proper operation in heating and outdoor coil in heating for airflow restrictions.

COMPONENT DIAGNOSTICS

Compressor

This compressor operates with a 3-phase variable frequency, variable voltage applied to the three fusite terminals. If compressor motor failure is suspected, check the phase resistances and the resistance between each phase and ground according to the parameters given in Table 4.

**Table 4 – Variable Speed Compressor Resistances (ohm)
(winding resistance at 68°F /20°C)**

WINDING	24	36	48	60
Between terminals T1, T2, and T3 (U,V,W)	.74	0.453	0.424	0.424
Between terminal & ground	>1 mega OHM			

Fan

CAUTION

EQUIPMENT DAMAGE HAZARD
 Failure to follow this caution may result in equipment damage or improper operation.
 Do not use Meggar for measuring the winding resistance.

If verification of proper operation is required for the ECM motor used in this unit, refer to [Fig. 12](#) and follow these steps:

1. Remove fan harness at VFD
2. Check the resistance between connector pins according to the expected resistances provided in [Table 5](#).

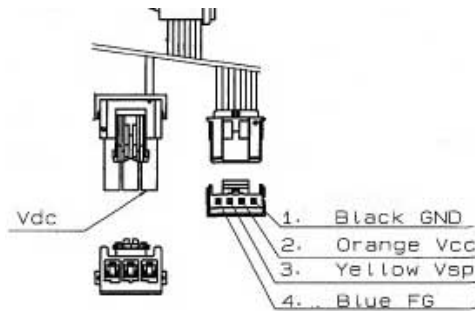

Fig. 12 – Fan Motor Connections

A200184

Table 5 – DC Voltage and PWM Measurement

Vdc-GND	Vcc-GND	Vsp-GND	FG-GND
Pin 1 (3 pin) & Pin 1 (4 pin)	Pin 2 (4 pin) & Pin 1 (4 pin)	Pin 3(4 pin) & Pin 1 (4 pin)	Pin 4 (4 pin) & Pin 1 (4 pin)
1.36 meg OHM	45.4 meg OHM	115k OHM	Open

Thermistors

The equipment uses four negative temperature coefficient (NTC) thermistors. As temperature of the sensor increases, its resistance decreases. The OAT, OCT and OST thermistors are nominally 10k-ohms at 77°F (25°C). The ODT thermistor is nominally 50k-ohms at 77°F (25°C). The PCM provides separate Open and Shorted diagnostics for each thermistor to indicate if the detected resistance goes outside of the normal sensing range.

[Table 6](#) provides a reference of resistance vs. temperature as a troubleshooting reference. Note that some of the thermistors may be at a temperature significantly different than ambient temperature if the equipment was recently operating. This is particularly true for ODT which could be much warmer than ambient and have a resistance reading lower than those shown in the table. The ODT thermistor will have a resistance as low as 2.2k-ohms if the discharge tube is near the compressor discharge operating limit at 240°F.

Table 6 – Thermistor Resistance (k-ohms) vs. Temperature

Temp (°F)	OAT-OCT-OST	ODT
0	85	430
10	62	310
20	46	230
30	35	170
40	26	130
50	20	99
60	15	77
70	11.9	59
80	9.3	46
90	7.3	37
100	5.8	29
110	4.7	23
120	3.8	19

Outdoor Ambient Temperature (OAT) Thermistor

The OAT thermistor is located at the bottom of the control box with the sensing element protruding through the bottom of the control box to be in contact with the outside air. The OAT thermistor location is illustrated in [Fig. 13](#).

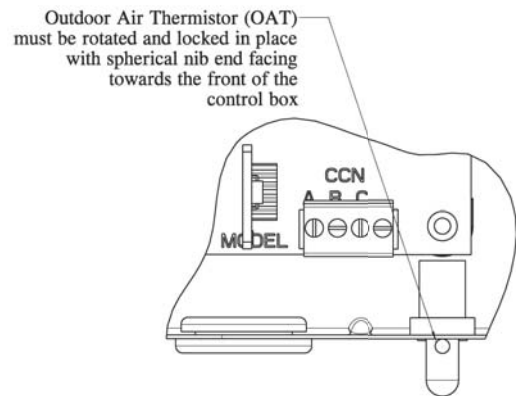

**Fig. 13 – Outdoor Air Thermistor (OAT) Attachment
(on control panel)**

A200045

If the OAT sensor fails, compressor operating speed may be limited to a reduced range of operation. When OAT is faulted and the equipment is running in heating mode, the reported value of OAT will be the same as OST. In all other conditions when OAT is faulted, the reported value of OAT will be the same as OCT.

Outdoor Coil Temperature (OCT) Thermistor

The OCT thermistor provides the coil/liquid line temperature to the PCM where it is used primarily for defrost control. The OCT thermistor is located on an extension tube on the outdoor coil. The sensor must be securely mounted to the location illustrated in [Fig. 14](#).

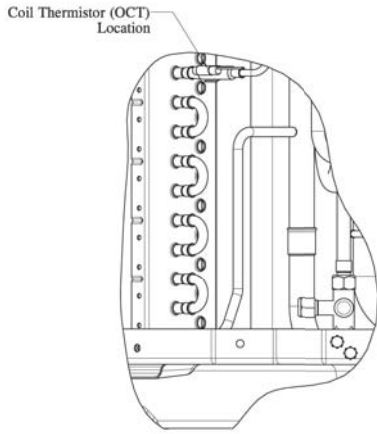

Fig. 14 – Outdoor Coil Thermistor (OCT) Attachment (On Coil Tube Extension)

A200046

If the OCT sensor fails, defrost will occur at a fixed 60-minute interval if operating in Auto mode, and the defrost cycle will run for the maximum allowable time. When OCT is faulted and the equipment is running in heating mode but defrost is not running, the reported value of OCT will be the saturated suction temperature. In all other conditions when OCT is faulted, the reported value of OCT will be the saturated discharge temperature.

Outdoor Discharge Temperature (ODT) Thermistor

⚠ CAUTION

EQUIPMENT DAMAGE HAZARD

Failure to follow this caution may result in equipment damage or improper operation.

In order to minimize the ambient influence, make sure the discharge thermistor curved surface hugs the pipe surface and is secured tight using the wire tie fished through the original slot insulating polymer body.

The ODT thermistor is used for determining discharge superheat and protecting the compressor from over-temperature operation. It must be secured tightly to the discharge tube and aligned parallel to the tube axis (see Fig. 15).

NOTE: ODT must be mounted inside of the sound blanket to reduce the influence of ambient temperature and provide accurate tube temperature.

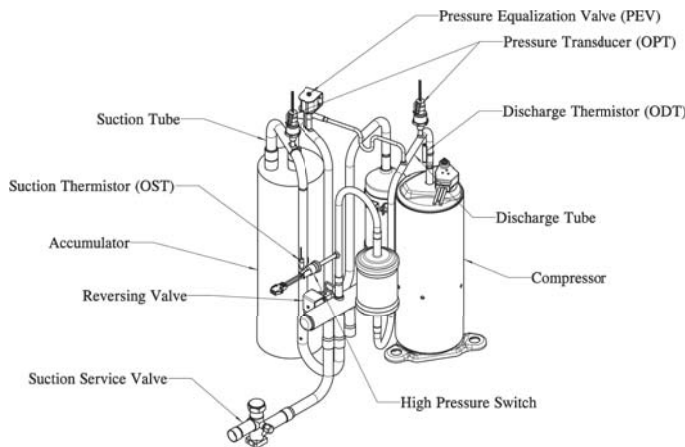

Fig. 15 – Suction Thermistor (OST) and Discharge Thermistor (ODT) Mounting Locations

A200047

If ODT sensor fails, compressor operation will be limited to 2700rpm. When ODT is faulted, the reported value of ODT will be 47°F.

Outdoor Suction Temperature (OST) Thermistor (284ANV Only)

The OST thermistor is used for calculating suction super heat during heating operation.. The OST thermistor must be secured tightly to the suction tube and aligned longitudinally to the vertical surface of the tube axis (see Fig. 15).

If OST sensor should fail, cooling operation will be unaffected, but heating operation will be disabled. OST faults are displayed as critical faults even during cooling operation so that service may be performed before heating is required..

Pressure Sensors

The equipment contains two pressure transducers:

- Suction Pressure Transducer (SPT)
- Discharge Pressure Transducer (DPT)

The two transducers are identical parts installed on the suction inlet to the compressor and discharge outlet of the compressor respectively. The transducers have a sensing range of 0 to 620 psig. The connection points to the PCM are labeled P1 and P2. These two connection points are identical. Either pressure transducer can be connected to either input. The software in the PCM detects which transducer is connected to which input and assigns the signals accordingly.

Signals used by control board for:

- Low pressure cut- out
- Loss of charge management,
- Compressor reliability management
- Discharge pressure cut-out
- Suction and Discharge super heat calculations

If the accuracy of either transducer is questioned, it can be checked while attached to the PCM. Connect a gauge manifold to the appropriate gauge port fitting and compare the gauge reading with the pressure reported by the PCM to the Evolution Control or to the Bryant Service Tech App. The connections at the PCM should be swapped to ensure the discrepancy is not related to PCM translation of transducer input signal. If suspect pressure measurement error follows transducer when connections are switched, replace transducer. If the suspect pressure measurement error changes to the other transducer when the connections are switched, replace the PCM.

Electronic Expansion Valves (EXV, Fig. 16)

While the EXV-H and EXV-VI valve bodies are different for different models, the stator for all valves have the same electrical properties. The EXV coil resistance should fall between 43 and 49 ohms when measured from common to remaining terminals. See Fig. 17 and Fig. 18.

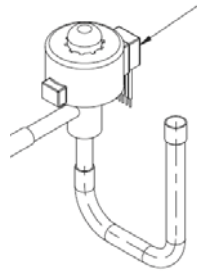
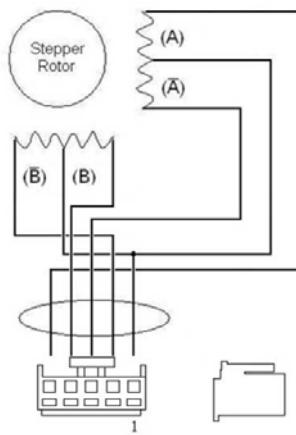

Fig. 16 – Electronic Expansion Valve (EXV)

A200182



TE P/N 1744498-5



TE P/N 1744498-5

Wire Color	Description	Pin Location
Gray	Excitation	Pin 1
Black	Phase B	Pin 2
Yellow	Phase A	Pin 3
Red	Phase B	Pin 4
Orange	Phase A	Pin 5

Fig. 17 – 284ANV EXV 5-wire Harness Heating EXV

A200215

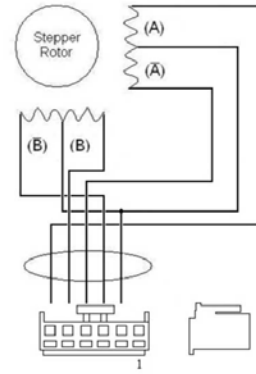

TE P/N 1744496-6



TE P/N 1744496-6

Wire Color	Description	Pin Location
n/a	(empty)	Pin 1
Gray	Excitation	Pin 2
Black	Phase B	Pin 3
Yellow	Phase A	Pin 4
Red	Phase B	Pin 5
Orange	Phase A	Pin 6

Fig. 18 – 186CNV060 / 284ANV060 EXV 6-wire Harness Vapor Injection EXV

A200216

Bluetooth Module

The Bluetooth module used with Bryant Service Tech App can collect recent fault codes, monitor system operation, and update software. The Bluetooth module is connected to the PCM via a wire harness mounted on the bottom horizontal section of control panel and is centered over the plastic insert to maximize transmission range of module. See appropriate fault code description for Bluetooth Module related faults. If unsuccessful with pairing while fault is not active, see service app for troubleshooting.

DIAGNOSTIC CODES AND TROUBLESHOOTING

Code 13-53 System Control Upgrade Strongly Recommended

Code 13-82 System Control Upgrade Recommended

Code 13-53 indicates that the system control is sufficiently out of date that the equipment will operate and that it is likely that the homeowner will take notice of sub-optimal behavior.

Code 13-82 indicates that the system control is out of date and should be upgraded to take full advantage of the features and functionality of the equipment system.

To correct codes 13-53 or 13-82, upgrade the system control to the latest version available.

Code 14-94 Line Voltage Low

Low line voltage may result in increased electronic component temperatures and shorten the life of VFD. Since control voltage is based on line voltage, solenoids and relays may not pull in and hold correctly as well. "Line Voltage Low" fault is set when incoming line voltage drops below 180V AC RMS at any time, or when line voltage drops below 185V AC RMS for more than 5 seconds. Once line voltage increases above 187V, the fault will clear. While fault is active unit will not operate or will shut down if already running. This fault does not escalate to a malfunction.

This measurement is taken at the secondary side of 24V transformer and a scaler value applied at the factory to correct for transformer variation.

Technician should first measure incoming line voltage at terminal block. Second, check tightness of all line voltage connections. Loose connections can cause excessive voltage drop and trigger this fault. If all connections are tight and line voltage is still low, additional steps involving the local power utility or addition of external power conditioner may be required.

Code 15-94 Line Voltage High

High line voltage may result in increased stress on electronic components and shorten the life of VFD. "Line Voltage High" fault is set when incoming line voltage rises above 285V AC RMS at any time, or when line voltage rises above 280V AC RMS for more than 5 seconds. Once line voltage drops below these thresholds the fault will clear. While fault is active unit will not operate or will shut down if already running. This fault does not escalate to a malfunction.

This measurement is taken at the secondary side of 24V transformer and a scaler value applied at the factory to correct for transformer variation. Technician should first measure incoming line voltage at terminal block using VOM. If voltage reading is below 285 VAC RMS, perform voltage calibration steps using service app. If VOM measured voltage is above 280VAC RMS, additional steps involving the local power utility or addition of external power conditioner may be required.

Code 17-06 Lost BTM Communication

The Bluetooth module used with Bryant Service Tech App can collect recent fault codes, monitor system operation, and update software. The Bluetooth module is connected to PCM via wire harness and is mounted on the bottom horizontal section of control panel and is centered over the plastic insert to maximize transmission range of module. After unit power up, the Bluetooth module will send periodic messages to PCM which confirm the status of module. If 2 consecutive minutes of messages are missing, code 17-06 will become active. Code 17-06 will clear when a single good message is received by PCM. If this fault is active, inspect PCM to Bluetooth module harness and ensure both ends are fully seated on board header. Also inspect and repair any wire

damage on harness. If no green or red led is present on the Bluetooth module, disconnect harness at the Bluetooth module and check for 18-30 VAC between pins 1 and 3 at the Bluetooth module connector end of harness. If voltage is present and code is active, replace Bluetooth module. An active code 17-06 will not affect system operation in any way except the service tool app will not connect to unit. If code is cleared and service app is not able to connect to Bluetooth module, follow troubleshooting steps in service app.

Code 18-11 Indoor Coil Freeze Protection

Code 18-11 indicates that the equipment is reducing compressor speed compared to the requested capacity demand in an effort to prevent ice accumulation on the indoor coil. The PCM monitors the saturated suction temperature at the compressor, and when the saturation temperature approaches 32°F, the compressor speed is reduced until the saturated suction temperature is above 32°F. If the compressor speed reduction is not able to achieve a saturated suction temperature above 32°F then it will continue to operate until either demand is removed or a 32-15 occurs.

Code 18-11 has been activated in PCM software versions 5.0 and above. This fault is not active in PCM software versions less than 5.0

Code 18-11 can be caused by insufficient airflow across the indoor coil due to a dirty filter or restrictive ductwork. Code 18-11 can also be caused by insufficient refrigerant charge in the system. Check the indoor equipment for excessive static air pressure and check refrigerant charge levels to correct this fault.

Code 24-58 5V PCM Power Out of Range Lockout

The PCM supplies 5V DC to VFD through the communication harness to power low voltage IC's (pin 4 of 6 pin wire harness). If this voltage is interrupted the VFD will cease to communicate with PCM. The PCM will continue to operate for a short period of time in case this interruption is intermittent, but if the voltage is not restored the system will shut down and declare code 24-58. The fault will clear once 5V DC is restored to VFD via PCM communication harness. The 5VDC on communication harness is shared with 5VDC powering pressure transducers.

When code 24-58 is active disconnect PCM to VFD communication harness and measure voltage between pin 3 (GND) and pin 4 (+5V DC) at the VFD connection end. If voltage is present, reconnect harness, power cycle, and check if fault is still present. If so, VFD will require replacement. If voltage is not present at VFD end of harness, check for voltage at the PCM header. If voltage is not present there, Disconnect all other sensors from PCM until fault is cleared. Whichever sensor is disconnected that makes fault disappear should be inspected for damage, likely a short exists in the harness. Once all sensors are disconnected and fault is present, confirm 5VDC is not present on PCM board, if not then replace PCM.

Code 25-22 Model Plug Missing

Code 25-62 Model Plug Missing Lockout

The Model Plug Missing Fault and Malfunction indicate that a model plug is not presently installed on the PCM or was not present when power was applied to the equipment. If a valid model plug has previously been installed, the PCM will have the most recently installed model plug value stored in memory.

Code 25-22 indicates that a valid model plug value is present in memory, but a model plug is not currently installed. If a Code 25-22 is active, the equipment will operate properly provided that the model plug value in memory corresponds to the equipment model. To clear Code 25-22, remove power from the equipment, install the model plug corresponding to the equipment model, and reapply power to the equipment.

Code 25-62 indicates that a valid model plug was not present when the equipment was powered up, and there is no valid model plug value stored in PCM memory. If a Code 25-62 is active, the equipment will not operate. The PCM will not acknowledge a new model plug installation while power is applied to the equipment. To clear Code 25-62, remove power from the equipment, install the model plug corresponding to the equipment model, and reapply power to the equipment. Code 25-62 can only be cleared by having a valid model plug installed when power is applied to the equipment.

Code 25-24 Model Plug Changed

Code 25-24 indicates that the model plug presently installed is different from the previously stored valid model plug value. Code 25-24 will be set when the equipment is powered up with a valid model plug value that is different from the stored model plug value in memory. A changed model plug will affect control configuration only if that model plug was present when power was applied to the equipment. Code 25-24 will be set if the model plug is changed to a different valid value or an invalid value while power is applied to the unit. If the model plug change is intentional, then no corrective action is required. Leave the new model plug in place and the code will clear on its own when power is removed and reapplied to the equipment. If the model plug change is not intentional, then remove power from the equipment, install the correct model plug, and reapply power to the equipment.

Code 25-61 Invalid Model Plug Lockout

Each system requires a model plug to be installed on the PCM. The model plug consists of two resistors in a unique combination. This model plug identifies the system size and type so PCM software can apply the relevant operating limits and reference correct operating tables. Code 25-61 designates the currently installed model plug is not valid and does not match any possible model in variable speed software. Consult unit installation instructions for model plug to unit model cross reference and replace model plug with correct part. While Code 25-61 is active, the unit will not be operable.

Code 25-63 VFD System Lockout - Model Mismatch

This code is generated when the sensed physical model plug is recognized but not compatible with the installed VFD. Check installed model plug against table in installation instructions for the model being serviced. Replace with correct VFD or model plug part.

Code 26-26 PCM MCU Old Version A

This fault is set when the PCM microcontroller on installed board is recognized as old. This board should not be used in the field and should be returned to Bryant for warranty replacement.

Code 26-27 PCM Reprogramming Failure

Code 26-27 indicates that an attempt for the PCM to reprogram itself failed. If this diagnostic is not recent, then a subsequent reprogramming attempt may have succeeded. The technician should check the current PCM software version against the latest software release. If the PCM software is not the most current, then the PCM should be reprogrammed manually using the Evolution Control or the Bryant Service Tech App.

Code 26-31 External EEPROM Write Failure

The PCM stores equipment configuration information in non-volatile EEPROM memory. An active Code 26-31 can be corrected only by replacing the PCM.

Code 28-71 Fuse 1 Open Lockout

This code will be set if fuse 1 is blown or missing on PCM board. Fuse 1 powers PEV, RVS, and Bluetooth module. When fuse 1 is open none of these components will function. AC units will operate if pressure differential is below the maximum allowable starting threshold (100psi), but HP units will not operate at all. The code will clear once short is removed and fuse is replaced with new, undamaged part. If fuse is blown there is a likely short in either the PEV, RVS, or Bluetooth module harnesses. If no physical damage is observed, begin by unplugging all components from PCM and make connections until replacement fuse opens. Harness should be repaired before replacing fuse. See wiring diagram for fuse size and location

Code 28-72 Fuse 2 Open Lockout

This code will be set if fuse 2 is blown or missing on PCM board. Fuse 2 only powers the LLS. When this fault is active the system will not operate. The code will clear once fuse is replaced with new, undamaged part. LLS are field installed accessories. Check LLS wiring for shorts. See wiring diagram for fuse size and location.

Code 31-11 Compressor High Pressure Limiting**Code 31-58 Compressor High Pressure Lockout**

This system contains a discharge pressure transducer to ensure compressor reliability. The high pressure limit is based on compressor model and varies with operating speed. When this fault occurs, the system will shut down and restart after 5 minute compressor protection time delay if demand is still present. Each time the fault occurs the maximum allowable compressor speed will be reduced by 25% until the minimum allowable compressor speed is reached. Each hour of compressor operation without fault re-occurrence will increase the compressor speed limit by 25%. This ensures that partial operation is still possible and system will self-correct if the issue causing fault is removed. Code 31-58 occurs when the compressor high pressure limit is reached while the compressor is at its minimum operating speed. System will "lock out" for 2 hours and attempt to resume normal operation afterwards. Multiple external factors may generate this fault: Dirty condenser, lack of airflow across condenser, condenser airflow recirculation, extreme high temperature and sun loading, refrigerant circuit blockage, faulty EXV/TXV, or overcharge.

Code 31-16 High Pressure Switch Shutdown

This system contains a 670psi high pressure switch as well as a discharge pressure transducer. This fault should not occur as the pressure transducer utilizes a separate high pressure limit at a lower setting. In the case of a fast transient this switch will safely disable system operation. This switch is connected directly to VFD and a break or short in wire harness during high pressure events will also generate fault. The high pressure switch quickly shuts down high voltage to VFD and additional communication faults may occur since the VFD will cease to communicate with PCM. The PCM/VFD will not attempt to resume system operation until discharge pressure has dropped below 425PSIG. Ensure HPS is closed and securely connected to VFD.

Code 31-19 High Pressure Disable

This fault is triggered when the discharge pressure is too high to start compressor (620psig). If refrigerant saturated pressure is high enough the system will be inoperable until pressures drop to acceptable range. Extreme high ambient temperatures may cause this fault to set and system will be inoperable during this time.

Code 32-15 Compressor Low Suction Shutdown**Code 32-55 Compressor Low Suction Lockout**

Exceeding soft and hard low pressure limits result in code 32-15. The soft low pressure limit can be exceeded for up to 2 minutes before code is generated, while exceeding the hard limit immediately results in code 32-15. Low pressure limits are compressor and rpm dependent, but 30psi and 15psi are typical. 4 occurrences of code 32-15 result in a 2hour lockout. Note: AEM will attempt to mitigate low pressure by adjusting system operation. This fault will only be set if system operation cannot be modified quickly enough to prevent exceeding hard and soft limits. A single occurrence of fault will result in 5 minute time delay followed by attempted restart if demand is still present.

Low pressure conditions can occur from multiple causes: Blockage in liquid line, stuck TXV or EXV, no airflow across evaporator, low system charge. Low ambient temperatures will increase diagnostic sensitivity to contributing factors above. Check pressure drop of liquid line at condenser and evaporator, confirm airflow across evaporator, and confirm system charge is correct. Replace EXV/TXV if necessary.

Code 32-59 Low Pressure Lockout

This fault is triggered when the suction pressure is too low to safely start the compressor. If refrigerant saturated pressure is low enough the system will be inoperable until pressures increase to acceptable range. System will be inoperable while this fault is active. The most likely cause of this fault is a leak in the refrigeration system.

Code 33-15 Compressor Low Discharge Shutdown**Code 33-55 Compressor Low Discharge Lockout**

Code 33-15 will become active if compressor is running and discharge pressure is below the lower safe operating boundary for a period of time. Discharge low pressure boundary only applies to the 5 ton model. Active envelope management will attempt to modify system operation to correct this condition before fault is set, but once time limit beyond the limit is exceeded the system will shutdown. 6 occurrences of code 33-15 within 2 hours will result in code 33-55 and 2 hour lockout.

Low discharge pressure can be caused by malfunctioning reversing valve, low charge, missing or stuck TXV/EXV, or compressor not operating properly.

Code 34-11 Compressor High Temp Limiting**Code 34-58 Compressor High Temp Lockout**

Code 34-11 will be set when discharge temperature exceeds 230F measured near the compressor. Low charge or very high superheat are contributors to this fault condition. For each occurrence of 34-11, the next startup will operate at a 25% reduction in capacity. Each hour of operation without additional faults will allow system to increase available capacity by 25%. Once the system is running at minimum capacity and discharge temperature exceeds 230F, code 34-58 will occur and shut down system for 2 hours.

Code 35-11 Compressor High Compression Limiting**Code 35-58 Compressor High Compression Lockout**

Code 35-11 occurs when the high compression boundary is crossed and AEM cannot adjust system operation to reduce compression ratio. For each occurrence of 35-11, the next startup will operate at a 25% reduction in capacity. Each hour of operation without additional faults will allow system to increase available capacity by 25%. Once the system is running at minimum capacity and the high compression boundary is crossed, code 35-58 will occur and shut down system for 2 hours. High compression ratio can be the result of overcharge or coil blockage/loss of airflow across heat exchanger.

Code 36-15 Compressor Low Compression Shutdown**Code 36-55 Compressor Low Compression Lockout**

Code 36-15 occurs when the low compression boundary is crossed and AEM cannot adjust system operation to increase compression ratio. Before this fault is set, AEM will automatically reduce outdoor fan speed (cooling only) to increase CR, then increase compressor speed. 4 occurrences of code 36-15 within 2 hours will result in code 36-55 and 2 hour lockout. Low compression ratio can be a result of compressor not increasing pressure adequately or low system charge.

Code 38-13 VFD Compressor Fault - Start Fail**Code 38-53 VFD Compressor Lockout - Start Fail**

Code 38-13 originates in VFD after additional compressor starting failures. While this code is active the unit opens PEV in an attempt to equalize pressure across compressor and continue start retries. After 3 consecutive code 38-13, malfunction 38-53 will be set with a 2 hour lockout

Check compressor wiring for secure connections, wire damage, and wire order. This code indicates that the VFD is not able to rotate the compressor rotor enough to complete starting process, indicating compressor damage or high pressure differential. If malfunctions continue to be generated and technician confirms pressure differential across compressor is <40psi, replace compressor.

Code 38-18 High Diff Pressure Start Disable

Attempting to start the compressor against a high pressure differential may result in start failures with an otherwise healthy compressor. The PEV is included to ensure compressor will never start against a high pressure differential. This fault will become active if a demand exists and the PEV is not successful in lowering pressure differential below

100psi. The fault will clear and unit will start normally once pressure differential is below 100psi and demand is still present.

The most likely cause of this fault is a non-functioning PEV. Possibly the PEV suffered a mechanical failure, or the coil is not mounted to PEV. Verify PEV coil is attached to PEV valve body. If coil is attached to body, replace PEV harness and coil first, and PEV body if problem is not fixed.

Code 38-31 VFD Compressor Fault - Estimator**Code 38-71 VFD Compressor Lockout - Estimator**

The VFD Estimator is used in the compressor starting process. While this fault is active the PEV will open and compressor will continue attempts at restarting. Three continuous code 38-31 will result in code 38-71 malfunction and 4 hour lockout. Repeated malfunctions indicate high starting torque and possible compressor damage. First, ensure the VFD model and compressor models are correct for unit being serviced as incorrect compressor motor parameters will not allow the VFD to complete the starting process correctly. If all parts are correct for the model being serviced, compressor damage exists and should be replaced.

Code 38-54 Compressor No Pump Lockout

This diagnostic checks to ensure the compressor is running in the correct direction and pumping properly. Once the compressor speed is >400rpm, the compressor has up to 30 seconds to increase the pressure differential (discharge pressure - suction pressure) by 20psi. If this pressure differential is not met, code 38-54 sets by locking operation for 30 minutes.

The most likely cause of this fault is the compressor leads being wired incorrectly. Check wire colors against wiring diagram to ensure UVW wires are attached to the correct terminals. Less likely but still possible is compressor motor shaft breakage allowing compressor motor to rotate but is disconnected from compression mechanism.

Fan Motor Faults General Info

The fan motor used on these models require 5 wires. 240~373 VDC is supplied through Pin 1 of 3 pin connector (VDC) and Pin 1 of 4 pin connector (GND). Pin 2 of 4 pin connector is Vcc signal for IC power supply (~15Vdc). Pin 3 of 4 pin connector is Vsp signal, which is 0-5VDC input speed control. Pin 4 of 4 pin is FG or feedback signal, sending rpm information back to VFD. The motor is controlled using a closed loop control where variable speed is increased or decreased by VFD depending on the RPM command from PCM to VFD along with actual RPM information read through FG pin. Use [Table 7](#) to confirm damaged electronics within fan motor. Note - winding resistance cannot be measured on fan motor due to embedded electronics. Note - resistances are approximate, temperature may affect measurements so only declare motor bad if results differ greatly from values in [Table 4](#). Though the fan motor has internal current protection, an external replaceable fuse is located on VFD for short circuit protection. See wiring diagram for fuse replacement specifications.

Code 39-13 Fan Start Failure**Code 39-53 Fan Start Failure Lockout**

When a demand startup begins a fan speed is commanded to VFD. After 25 seconds of FG (fan speed feedback signal) = 0, the PCM will reset the VFD and try to start fan again. After 3 VFD resets Code 39-13 will be set. PCM will continue to reset VFD a total of 6 times before declaring code 39-53 and locking out for 1 hour. A successful fan start will reset the fan start failed counter.

Inspect all wiring and connectors for damage and loose connections. Check for fan blade blockage and free spin. Check external fan fuse. If no physical blockage is present and fuse is not open, ohm motor and replace if necessary.

Code 39-14 Fan Speed Error

A code 39-14 is declared when the commanded speed is greater than 200rpm and differs from actual speed (as reported from fan to VFD) by more than 20%. This fault is also declared when the commanded speed is 0 and the VFD is receiving greater than 80rpm feedback from fan motor. The most likely scenario for this fault is a partial physical blockage of blade, ice buildup on fan blade, extreme coil blockage that loads blade heavily, or bearings with high resistance to spinning.

Code 39-15 Unexpected Fan Shutdown**Code 39-55 Unexpected Fan Lockout**

A code 39-15 is declared when VFD commanded speed is above 200rpm and actual speed is reduced to less than 80rpm as reported via VFD for 10 seconds consecutively after starting. The fault triggers compressor and fan shutdown, then VFD reset. If demand is still present the system will attempt to restart normally and run. An intermittent open connection on fan FG wire or a failing fan motor may create these faults.

Code 39-58 VFD System Lockout - Fan Motor Fail

Code 39-58 originates in the VFD control when fan motor feedback signal (FG) is not received while a Vsp value has been sent to fan motor for 30 seconds. The fault can also be set when speed error between feedback and command is greater than 100rpm. This fault should never occur because code 39-15 will be declared after 10 seconds. When fault is active, compressor and fan are shut down and lockout time is 30 minutes. Internal electrical damage is likely causing FG feedback to not be received by VFD. Replace fan motor 1st, then VFD.

Code 41-13 Defrost Timeout

This system operates using both a time and temperature requirement. After a predetermined length of time at a possible coil frosting condition (OCT below 35F) defrost will be initiated. OCT is monitored and will complete defrost cycle once it reaches a target value dependent on model and OAT value. Code 41-13 is triggered when defrost is terminated on maximum time and the target coil temperature has not been reached. This may indicate an extreme amount of ice formed on coil or the OCT sensor not being securely attached to butterfly tube. This fault may also trigger if high winds are present and are cooling the coil, not allowing heat to build and melt frost or ice.

Code 44-13 PEV Timeout

The PEV is used to equalize suction and discharge pressures and lessen the starting torque required from compressor and VFD. The PEV will open 2.5 minutes after compressor shutdown if pressure differential is between 200-300psi or if pressure differential is greater than 50psi and demand is present. In both cases PEV will open until differential pressure is less than 40psi. Code 44-13 will be set if PEV is open for 10 minutes and does not reduce pressure differential below 40psi. If this occurs it is likely the valve or coil has failed. Replace PEV coil and harness first and if fault persists open refrigeration system and replace PEV valve itself. This fault will not prevent system from starting, but will likely be accompanied by another fault.

Code 51-01 OAT Open

The outdoor air thermistor determines operating range of compressor and fan speeds in cooling and heating operating modes. When "OAT Open" fault is active, the OCT will be substituted in its place and compressor operating speed will be limited to 2700rpm. Fan speeds will be limited based on OCT value. The sensor is monitored continuously and if resistance is above 465kohm for 1 second this fault will occur. Once sensor value drops below 465kohm for 1 second the fault will clear. This fault does not escalate to a malfunction.

If the resistance value of OAT thermistor is higher than the electrical circuit is capable of measuring, this fault will be generated. Measure resistance value of thermistor at the PCM connector. If value is above 465kohm, look for a break in the wiring or at the connector itself. If no breaks are observed, replace sensor. If measured resistance is within allowable range, replace PCM.

Code 51-02 OAT Shorted

The outdoor air thermistor determines operating range of compressor and fan speeds in cooling and heating operating modes. When "OAT Shorted" fault is active the OCT value will be substituted in its place, and compressor operating speed will be limited to 2700rpm. Fan speeds will be limited based on OCT value. The sensor is monitored continuously and if resistance is below 1kohm for 1 second this fault will occur. Once sensor value increases above 1kohm for 1 second the fault will clear. This fault does not escalate to a malfunction.

If the resistance value of OAT thermistor is lower than the electrical circuit is capable of measuring, this fault will be generated. Measure resistance value of thermistor at the PCM connector. If value is below 1kohm, look for bare wire, short in the wiring, or at the connector itself. If no bare wires or shorts are observed, replace sensor. If measured resistance is within allowable range, replace PCM.

Code 52-01 OCT Open

The outdoor coil thermistor is used to determine when the outdoor coil is completely cleared during defrost. For this reason all defrosts performed when this fault is active will occur for the maximum time length allowed by software. The sensor is monitored continuously and if resistance is above 465kohm for 1 second this fault will occur. Once sensor value drops below 465kohm for 1 second the fault will clear. This fault does not escalate to a malfunction.

Measure resistance value of thermistor at the PCM connector. If value is above 465kohm, look for a break in the wiring or at the connector itself. If no breaks are observed, replace sensor. If measured resistance is within allowable range, replace PCM.

*Note if any combination of OAT and OCT shorted/open are present the system will limit operation based on each individual fault.

Code 52-02 OCT Shorted

The outdoor coil thermistor is used to determine when the outdoor coil is completely cleared during defrost. For this reason all defrosts performed when this fault is active will occur for the maximum time length allowed by software. The sensor is monitored continuously and if resistance is below 1kohm for 1 second this fault will occur. Once sensor value increases above 1kohm for 1 second the fault will clear. This fault does not escalate to a malfunction.

Measure resistance value of thermistor at the PCM connector. If value is below 1kohm, look for a short in the wiring or at the connector itself. If no shorts are observed, replace sensor. If measured resistance is within allowable range, replace PCM.

*Note if any combination of OAT and OCT shorted/open are present the system will limit operation based on each individual fault.

Code 53-41 OST Open - Backup Heat Only

The suction thermistor is required for control of the outdoor EXV in HP systems. For this reason, heating mode operation will be locked out if the OST is determined to be open or shorted. Cooling operation will be allowed if OST is not functional, though on HP systems the malfunction will be displayed on wall control screen. This will remind homeowner to repair the sensor before heating season. Open OST sensor value will default to "47" on status or checkout display. The sensor is monitored continuously and if resistance is above 465kohm for 1 second this fault will occur. Once sensor value drops below 465kohm for 1 second the fault will clear.

Measure resistance value of thermistor at the PCM connector. If value is above 465kohm, look for a break in the wiring or at the connector itself. If no breaks are observed, replace sensor. If measured resistance is within allowable range, replace PCM.

Code 53-42 OST Shorted - Backup Heat Only

The suction thermistor is required for control of the outdoor EXV in HP systems. Similar to "OST Open" fault, heating mode operation will be locked out if the OST is determined to be open or shorted. Cooling operation will be allowed if OST is not functional, though on HP systems the malfunction will be displayed on wall control screen. This will remind homeowner to repair the sensor before heating season. Shorted OST sensor value will default to "47" on status or check-out display. The sensor is monitored continuously and if resistance is below 1kohm for 1 second this fault will occur. Once sensor value rises above 1kohm for 1 second the fault will clear.

Measure resistance value of thermistor at the PCM connector. If value is below 1kohm, look for bare wire, short in the wiring, or at the connector itself. If no bare wires or shorts are observed, replace sensor. If measured resistance is within allowable range, replace PCM.

Code 54-01 ODT Open

The discharge thermistor is used to protect the compressor and ensure discharge superheat is present at all times. When "ODT Open" malfunction is active 47 will be substituted by default. The sensor is monitored continuously and if resistance is above 310kohm for 1 second this malfunction will occur. Once sensor value drops below 310kohm for 1 second the malfunction will clear. Since achieving discharge superheat is an integral requirement for startup, when this sensor does not read a valid value, the system will only run at startup speed. Normal operation will resume once valid ODT value is read by PCM.

Measure resistance value of thermistor at the PCM connector. If value is above 310kohm, and OAT and OCT measure above 25F, look for a break in the wiring or at the connector itself. If no breaks are observed, replace sensor. If measured resistance is within allowable range, replace PCM.

Code 54-02 ODT Shorted

The discharge thermistor is used to protect the compressor and ensure discharge superheat is present at all times. When "ODT Shorted" malfunction is active 47 will be substituted by default. The sensor is monitored continuously and if resistance is below 670 ohm for 1 second this malfunction will occur. Once sensor value rises above 670 ohm for 1 second the malfunction will clear. Since achieving discharge superheat is an integral requirement for startup, when this sensor does not read a valid value, the system will only run at startup speed. Normal operation will resume once valid ODT value is read by PCM.

Measure resistance value of thermistor at the PCM connector. If value is below 670 ohm, look for a short in the wiring or at the connector itself. If no shorts are observed, replace sensor. If measured resistance is within allowable range, replace PCM.

Code 57-01 P1 Open Fault**Code 57-41 P1 Open Lockout****Code 58-01 P2 Open Fault****Code 58-41 P2 Open Lockout**

Pressure transducers are dynamically assigned based on their relative values within PCM software. This feature allows the pressure transducers and harnesses to be interchangeable. Each pressure transducer requires 3 wires: Ground (BLK), Power (+5V DC, RED), and Signal (GRN). The ratio of voltage between power and signal wires is converted into a pressure value. If the signal is above or below the pressure transducers ability to measure it may be because the power wire is not supplying 5V DC or the signal wire is not returning a DC Voltage between 0.5-4.5 VDC. A base code of 57 or 58 is determined based on which PCM connection has the issue, P1 or P2. The expansion codes 01 and 41 explain the type of issue, in this case "open", meaning the signal wire is returning more than 4.5V DC. The most likely cause of this the sensor wire being disconnected and the PCM board "pulling" up the signal voltage to +5V DC.

Code 57-02 P1 Shorted Fault**Code 57-42 P1 Shorted Lockout****Code 58-02 P2 Shorted Fault****Code 58-42 P2 Shorted Lockout**

Pressure transducers are dynamically assigned based on their relative values within PCM software. This feature allows the pressure transducers and harnesses to be interchangeable. Each pressure transducer requires 3 wires: Ground (BLK), Power (+5V DC, RED), and Signal (GRN). The ratio of voltage between power and signal wires is converted into a pressure value. If the signal is above or below the pressure transducers ability to measure it may be because the power wire is not supplying 5V DC or the signal wire is not returning a DC Voltage between 0.5-4.5 VDC. A base code of 57 or 58 is determined based on which PCM connection has the issue, P1 or P2. The expansion codes 02 and 42 explain the type of issue, in this case "shorted", meaning the signal wire is returning less than 0.5V DC. The most likely cause of this the sensor wire being shorted to the metal chassis.

Code 57-43 P1 Sensor Lockout**Code 58-43 P2 Sensor Lockout**

Pressure transducers are dynamically assigned based on their relative values within PCM software. For this reason the pressure transducers and harnesses are interchangeable. Each pressure transducer requires 3 wires: Ground (BLK), Power (+5V DC, RED), and Signal (GRN). The ratio of voltage between power and signal wires is converted into a pressure value. The pressure transducer is capable of sending a value to PCM via sensor wire if it is not working correctly. A base code of 57 or 58 is determined based on which PCM connection has the issue, P1 or P2. When a DC V value of 4.84-4.95 is returned to PCM it will trigger 57-43 or 58-43 fault. The most likely cause of this is a failed transducer part. Switch the harnesses from P1 and P2 to see if the malfunction follows the transducer. If so, follow procedure to replace failed pressure transducer. Trace wires from PCM board connection to ensure correct transducer is being replaced.

Code 61-13 Reversing Valve Timeout Fault**Code 61-53 Reversing Valve Timeout Lockout**

Applies to HP only. The reversing valve is required to be energized for cooling operation and for defrosting during heating operation. The reversing valve will only actuate when the pressure difference between the suction and discharge of the compressor is above a minimum level. The 61-13 will be set whenever the minimum pressure condition prevents a reversing valve switch for 10 minutes. The 61-53 will be set when the 61-13 has been set 4 times in 2 hours. The 61-53 will result in a 2 hour lockout. When this fault occurs it may be due to the reversing valve being stuck between the heating and cooling positions, or the compressor is not pumping properly. If this lockout occurs repeatedly then a reversing valve or compressor replacement may be needed.

Code 61-41 RVS Open Lockout

Applies to HP only. Reversing valve is required to be energized for cooling operation, and for defrosting during heating operation, therefore the system will declare 61-41 when it senses the reversing valve coil is "open" or infinite resistance, and not operational. This check can only be performed when the reversing valve is not energized so it is possible that a reversing valve coil failure during the cooling season may not be identified since the reversing valve continues to be powered between cooling cycles. In this case the system will not declare a fault but the reversing valve will be in the heating position.

Remove RVS connector from PCM and measure continuity between pins 1 & 3. If open or shorted, inspect wire for damage and repair if necessary. If no damage is found, replace coil and harness.

Code 62-01 PEV Solenoid Open

PEV (pressure equalization valve) is used to equalize pressures across the compressor prior to starting in order to ensure the compressor can align itself and start with minimal effort. The system will declare 62-01 when it senses the PEV coil is "open" or infinite resistance. The system will continue to operate while this fault is active as long as the pressures are within acceptable range prior to start attempt. If not, the system will not start until pressure differential drops to acceptable range.

Remove PEV connector from PCM and measure continuity between pins 1 & 3. If open, inspect wire for damage and repair if necessary. If no damage is found, replace coil and harness.

Code 64-41 EXV-H Phase Open Lockout

Applies to HP only. EXV-H is required to control superheat in heating mode. Each time power is applied to outdoor unit the EXV-H will operate to a known position as the valve does not have the capability to feedback actual position. The PCM software must know the starting point and then count as EXV stepper motor is pulsed. At the end of each cycle the valve will close to help maintain pressure differential and optimize cyclic efficiency. HP units will not operate if this fault is active because the valve position at time of failure is unknown.

This code occurs when the PCM determines the resistance of the stepper motor coil circuit is above the maximum value to properly function. Inspection of the wire harness and plug should be performed, as well as using multimeter to confirm "open" continuity between pins. If nothing is found, replace coil and harness assembly.

Code 64-44 EXV-H Power Shorted Lockout

Applies to HP only. EXV-H is required to control superheat in heating mode. Each time power is applied to the unit, the EXV-H will operate to a known position as the valve does not have the capability to feedback actual position. The PCM software must know the starting point and then count when stepper motor is pulsed. At the end of each cycle the valve will close to help maintain pressure differential and optimize cyclic efficiency. HP units will not operate if this fault is active because the valve position at time of failure is unknown.

This code occurs when the PCM determines the EXV power supply is drawing excessive current. The most likely cause of this fault is the wire attached to pin 1 of EXV-H connector being shorted to ground. Inspection of the wire harness and plug should be performed, as well as using multimeter to confirm "short to ground" continuity. If nothing is found, replace coil and harness assembly.

Code 64-45 EXV-H Phase Shorted Lockout

Applies to HP only. EXV-H is required to control superheat in heating mode. Each time power is applied to the unit, the EXV-H will operate to a known position as the valve does not have the capability to feedback actual position. The PCM software must know the starting point and then count when stepper motor is pulsed. At the end of each cycle the valve will close to help maintain pressure differential and optimize cyclic efficiency. HP units will not operate if this fault is active because the valve position at time of failure is unknown.

This code occurs when the PCM determines the EXV power supply is drawing excessive current. The most likely cause of this fault is one or more wires attached to pins 2-5 of EXV-H connector being shorted to ground. Inspection of the wire harness and plug should be performed, as well as using multimeter to confirm "short to ground" continuity. If nothing is found, replace coil and harness assembly.

Code 65-41 EXV-VI Phase Open Lockout

Applies to 5T AC and HP only. EXV-VI is required to operate the vapor injection circuit which is used in high demand situations such as high ambient cooling or low ambient heating. Once per day the EXV-VI will test itself by operating to a known position as the valve does not have the capability to feedback actual position. The PCM software must know the starting point and then count when stepper motor is pulsed. The valve will remain closed until additional capacity is needed.

This code occurs when the PCM determines the resistance of the stepper motor coil circuit is above the maximum value to properly function. Inspection of the wire harness and plug should be performed, as well as using multimeter to confirm "open" continuity between pins. If nothing is found, replace coil and harness assembly.

Code 65-44 EXV-VI Power Shorted Lockout

Applies to 5T AC and HP only. EXV-VI is required to operate the vapor injection circuit which is used in high demand situations such as high ambient cooling or low ambient heating. Once per day the EXV-VI will

test itself by operating to a known position as the valve does not have the capability to feedback actual position. The PCM software must know the starting point and then count when stepper motor is pulsed. The valve will remain closed until additional capacity is needed.

This code occurs when the PCM determines the EXV power supply is drawing excessive current. The most likely cause of this fault is the wire attached to pin 1 of EXV-H connector being shorted to ground. Inspection of the wire harness and plug should be performed, as well as using multimeter to confirm "short to ground" continuity. If nothing is found, replace coil and harness assembly.

Code 65-45 EXV-VI Phase Shorted Lockout

Applies to 5T AC and HP only. EXV-VI is required to operate the vapor injection circuit which is used in high demand situations such as high ambient cooling or low ambient heating. Once per day the EXV-VI will test itself by operating to a known position as the valve does not have the capability to feedback actual position. The PCM software must know the starting point and then count when stepper motor is pulsed. The valve will remain closed until additional capacity is needed.

This code occurs when the PCM determines the EXV power supply is drawing excessive current. The most likely cause of this fault is one or more wires attached to pins 2-5 of EXV-H connector being shorted to ground. Inspection of the wire harness and plug should be performed, as well as using multimeter to confirm "short to ground" continuity. If nothing is found, replace coil and harness assembly.

Code 66-41 VFD Control Relay Open Lockout

The PCM commands the VFD to close a relay in the power circuit during VFD initialization. If PCM senses the VFD relay coil is open this code is set. While this code is active the VFD will not be powered and system is inoperable. 12VDC is fed from Pins 6&7 of the PCM into pins 5&6 of the VFD via communication cable as long as system is ready to run (other faults that stop system from operation are not active).

To troubleshoot this fault, remove the PCM-VFD harness from the PCM while leaving the other end connected to the VFD. Check the resistance between the pins 6 & 7 of the harness connector. The resistance should be approximately 720 ohms. If the resistance is much higher than 720 ohms, then remove the connector at the other end of the cable from the VFD. Check the resistance between pin 6 of the PCM connector and pin 5 of the VFD connector, then pin 7 of the PCM connector and pin 6 of the VFD connector. If either of these shows a resistance higher than just a few ohms, then the cable is the cause of the problem. If the cable checks OK, the problem may be with the VFD. Check the resistance between pins 5 and 6 of the VFD connector. If this resistance is significantly higher than 720 ohms, then the problem is within the VFD.

Code 66-42 VFD Control Relay Shorted Lockout

The PCM commands the VFD to close a relay in the power circuit during VFD initialization. If PCM senses the VFD relay coil is shorted to ground this code is set. While this code is active the VFD will not be powered and system is inoperable. 12VDC is fed from Pins 6&7 of the PCM connector into pins 5&6 of the VFD connector via communication cable as long as system is ready to run (other faults that stop system from operation are not active). Check to ensure comm harness is not damaged and shorting to ground or another wire.

To troubleshoot this fault, remove the PCM-VFD harness from the PCM while leaving the other end connected to the VFD. Check the resistance between the pins 6 & 7 of the harness connector. The resistance should be approximately 720 ohms. If the resistance is much lower than 720 ohms, then remove the connector at the other end of the cable from the VFD. Check the resistance between pins 5 and 6 of the comm cable connection at VFD. If this resistance is significantly lower than 720 ohms, then the problem is within the VFD.

VFD Related Faults General Info

Occasional VFD faults may occur that are caused by specific external circumstances. In these cases the VFD will self-recover and continue to operate normally. Once faults escalate to malfunctions permanent damage may be present. The service person should use judgement when replacing components to determine if occasional external conditions are present or if equipment is damaged and require replacement because system is not providing expected performance.

Code 81-13 VFD System Fault - PFC**Code 81-53 VFD System Lockout - PFC**

The power factor correction circuit (PFC) in VFD introduces an inductance which corrects the current phase shift inherent with powering motors. This in turn minimizes the reactive power transmitted back to input power cables. This fault is set when the PFC circuit exceeds a peak current limit when driving compressor. System will shut down and VFD will reset, if demand persists, system will attempt to resume normal operation. After 2 occurrences within 10 minutes, code 81-53 is set and system is locked out for 4 hours. A power cycle will clear malfunction lockout timer. Continued malfunctions indicate high current situation. This is likely due to VFD or compressor damage. Measure reactor(s) resistance. As reactor charges the resistance will be reduced to 0. If measurement is open, replace reactor. Otherwise replace VFD.

Code 81-14 VFD System Fault - Unbalanced PFCM**Code 81-54 VFD System Lockout - Unbalance PFCM**

Applicable to 4 and 5 ton models only with multiple reactors. This fault occurs when current in PFCM circuits is not balanced. It is most likely caused by a disconnected or faulty reactor. The VFD will shut down and attempt to restart after each occurrence of code 81-14. After 2 occurrences within 10 minutes, code 81-54 is set and system is locked out for 4 hours.

Disconnect and measure resistance of both reactors in system. As reactor charges the resistance will be reduced to 0. If measurement is open, replace reactor. Otherwise replace VFD.

Code 81-58 VFD System Lockout - Wiring Error

This fault occurs when the VFD senses that 1 or more of the compressor wires are not connected to VFD. While this fault is active the system is inoperable. Check compressor wire harness at each end and ensure connections are tight fitting and wires are undamaged. Perform continuity test on compressor harness with DMM. Check resistance of compressor windings at VFD end of compressor harness to ensure no windings are open. Refer to [Table 4](#) for compressor winding resistance by outdoor model.

Code 82-11 VFD System Fault - Line Current Lim

The VFD monitors input current and will limit or reduce compressor speed if the current rises above threshold. Current limits are model specific. While code 82-11 is active the VFD will continue to operate compressor at a reduced or limited speed, while fan operation will not be affected directly. This code will clear once VFD input current drops below threshold. Low input voltage combined with high load is the most likely cause of this code. Check system for overcharge and indoor/outdoor coil blockage as well as input voltage.

Code 82-13 VFD Reset with Power Dropout**Code 82-53 VFD Lockout - Reset with Power Drop**

This code indicates the VFD has reset itself due to a line voltage loss. When this code is set the PCM will complete a shutdown, reset the VFD, and restart if demand is still present. The system should resume operation after the 5 minute compressor protection time delay expires. 3 occurrences of code 82-13 within a 1 hour period will result in a code 82-53 and 2 hour lockout. Occasional occurrences of this code may happen due to momentary power loss or electrical noise from utility. Check tightness of all line voltage connections. Loose connections can cause momentary voltage drop due to vibration and trigger this fault. If all connections are tight, additional steps involving the local power utility or addition of external power conditioner may be required.

Code 82-15 VFD Fault with Power Dropout**Code 82-55 VFD Lockout - Fault with Power Drop**

This code indicates the VFD has shutdown due to a line voltage loss. When this code is set the PCM reset the VFD, and restart if demand is still present. The system should resume operation after 5 minute compressor protection time delay expires. 4 occurrences of code 82-15

within a 1 hour period will result in a code 82-55 and 2 hour lockout. Occasional occurrences of this code may happen due to momentary power loss or electrical noise from utility. This code can be paired with other codes if electrical noise is present. Check tightness of all line voltage connections. Loose connections can cause momentary voltage drop due to vibration and trigger this fault. If all connections are tight, additional steps involving the local power utility or addition of external power conditioner may be required.

Code 82-16 VFD System Fault - Low Line Volt**Code 82-56 VFD System Lockout - Low Line Volt**

The VFD monitors line voltage and will set code 82-16 if line voltage drops below 180VAC peak. When code 82-16 occurs the system will shut down and reset VFD. System will attempt to resume operation once 5 minute compressor protection timer expires. 4 occurrences of code 82-16 in a 1 hour period will result in code 82-56 and will shut down equipment for a 2 hour lockout. Measure input voltage with a power quality analyzer and contact power utility provider if necessary.

Code 82-17 VFD System Fault - High Line Volt**Code 82-57 VFD System Lockout - High Line Volt**

The VFD monitors line voltage and will set code 82-17 if line voltage rises above 410VAC peak. When code 82-17 is occurs the system will remain operating as it is likely caused by a momentary voltage spike that will not damage the VFD. If a long term unsafe high voltage event occurs, the PCM will generate a 15-94 and shut down equipment. 10 events of code 82-17 in a 1 hour period will result in code 82-57 and will shut down equipment for a 2 hour lockout. Measure input voltage with a power quality analyzer and contact power utility provider if necessary.

Code 83-11 VFD Compressor Fault - Current 1**Code 83-12 VFD Compressor Fault - Current 2**

The VFD monitors multiple compressor current conditions and will limit or reduce compressor speed if the current rises above threshold. Current limits are model specific. While codes are active the VFD will continue to operate compressor at a reduced or limited speed, and fan operation will not be affected directly. This code will clear once compressor current drops below threshold. This code indicates the compressor may have minor damage and requires slightly higher torque (current) to operate at desired rpm. If damage continues to worsen the compressor may cause code 83-15, 83-55, 83-16, and 83-56. Check system for overcharge and indoor/outdoor coil blockage as well as input voltage. Listen to compressor during operating for abnormal noise indicating physical damage. If code persists or compressor has abnormal noise, replace compressor.

Code 83-15 VFD Compressor Fault - Current 3**Code 83-55 VFD Compressor Lockout - Current 3****Code 83-16 VFD Compressor Fault - Current 4****Code 83-56 VFD Compressor Lockout - Current 4**

The VFD monitors multiple compressor current conditions and will limit or reduce compressor speed if the current rises above threshold. Current limits are model specific. Code 83-15, 83-16, 83-55, and 83-56 will result if the VFD is not capable of reducing compressor speed far enough or fast enough while running. This code will shut down system and attempt restart after 5 minute compressor protection timer has expired. 2 instances of code 83-15/83-16 in a 4 hour period will result in code 83-55/83-56 and a 2 hour lockout. These codes indicate the compressor requires higher torque (current) to operate at desired rpm. Check system for overcharge and indoor/outdoor coil blockage as well as input voltage. Check wiring from VFD to compressor for poor connections causing high current. Check compressor winding resistance against table. Listen to compressor during operating for abnormal noise indicating physical damage. VFD may have internal damage causing high current, or compressor may be damaged.

Code 83-57 VFD Compressor Lockout - Current I

This code will be set when any of the VFD compressor speed limiting codes are active and the compressor speed is reduced below the lowest allowable operating speed for a given OAT. Once 1 hour lockout timer expires the unit will attempt to resume operation. This code indicates the compressor requires higher torque (current) to operate at desired rpm and compressor is mechanically damaged. If code persists, replace compressor.

Code 84-11 VFD Heatsink Overtemp Fault**Code 84-58 VFD Heatsink Overtemp Malfunction**

The VFD has internal temperature sensors to monitor critical power components and take action if operating temperatures cross thresholds that may shorten the VFDs operating life. If the heat sink temperature sensor fails, it will no longer be capable of preventing critical power components from operation above the safe reliable temperature threshold. This fault will be set when the VFD IPM or PFCM temperatures are greater than or equal to 203°F.

If this fault is active, the VFD will shut down compressor but continue to operate fan to draw air across heat sink. Once heat sink temperature is acceptable, system will restart but reduce demand by 25% for each occurrence of 84-11. Once speed can no longer be reduced further, code 84-58 will be set and system locked out for 2 hours. Each hour of operation without additional code 84-11 will allow increased demand of 25%. The most likely cause is restricted airflow over heat sink. Inspect and clear heatsink of anything that may inhibit airflow or contact with air. A less likely possibility is inadequate contact of power components with heat sink, not allowing intended heat transfer between components and heat sink. If clearing heatsink of blockage does not eliminate codes, replace VFD.

Code 85-13 VFD System Fault - DC Under Voltage**Code 85-53 VFD System Lockout - DC Under Volt**

The VFD boosts line voltage and uses the PFC circuit to maintain DC voltage within an acceptable range. Code 85-13 is set when the DC voltage is lower than the acceptable lower limit of 180VDC. Attempting to operate VFD below minimum DC voltage can cause failed/reduced compressor or fan operation. 4 occurrences within 1 hours result in 85-53 malfunction which has a 2 hour lockout time. An instance of 85-13 will result in VFD shutdown and system restart once 5 minute compressor protection timer expires. Low AC line voltage, quickly loading the compressor, or a damaged PFC circuit in VFD may result in a code 85-14. Check to ensure reactors are plugged in securely. Manually power cycle outdoor unit with disconnect, if malfunction persists replace reactors, then VFD.

Code 85-14 VFD System Fault - DC Over Voltage**Code 85-54 VFD System Lockout - DC Over Volt**

The VFD boosts line voltage and uses the PFC circuit to maintain DC voltage within an acceptable range. Code 85-14 is set when the DC voltage exceeds the acceptable upper limit of 410VDC. Exceeding maximum DC voltage can damage electrical circuits or shorten VFD's operating life. 4 occurrences within 1 hours result in 85-54 malfunction which has a 2 hour lockout time. An instance of 85-14 will result in VFD shutdown and system restart once 5 minute compressor protection timer expires. High AC line voltage or quickly unloading the compressor may result in a code 85-14. Manually power cycle outdoor unit with disconnect, if malfunction persists replace VFD.

Code 86-06 VFD System Fault - Communication**Code 86-46 VFD System Lockout - Communication**

If communication between VFD and PCM does not occur for a continuous 15 seconds, code 86-06 is set by PCM. 3 occurrences within 15 minutes will result in 86-46 malfunction, which has a 1 hour lockout. When code 86-06 is set, VFD will shut down compressor and fan, and re-initialize in an attempt to re-establish communication between VFD and PCM. Inspect PCM to VFD communication harness for damage and

connectivity, replace if necessary. If this does not fix problem, the VFD communicating components have been damaged and PCM or VFD requires replacement.

Code 87-13 VFD Initialization Fault**Code 87-53 VFD System Lockout - Initialization**

The VFD communicates identification information to PCM when initializing to run. This information is used to identify the equipment and reference correct operating tables. When unrecognized information is received the PCM will set fault 87-13 and reset the VFD to restart the initialization process. After 3 instances of fault 87-13 within 4 hour period 87-53 malfunction is set and system is locked out for 4 hours. The most likely cause of this fault is an incorrect model plug. Check for correct model plug in model plug table.

Code 88-15 VFD Internal Fault - Unexpect Reset**Code 88-55 VFD Lockout - Unexpected Reset**

Communication between the VFD and PCM is monitored continuously. If communication fails, the PCM will initiate a VFD reset in an attempt to restart the communicating components of VFD. The system will shut down and restart after 5 minute compressor protection timer expires. Three occurrences of code 88-15 within a 1 hour period will result in 88-55 malfunction and 2 hour lockout. Inspect PCM to VFD communication harness for damage and connectivity, replace if necessary. If this does not fix problem, the VFD communicating components have been damaged and VFD requires replacement.

Code 88-27 VFD Reprogramming Failure

Code 88-27 indicates that an attempt to reprogram the VFD failed. If this diagnostic is not recent, then a subsequent reprogramming attempt may have succeeded. The technician should check the current VFD software version against the latest software release. If the VFD software is not the most current, then the VFD should be reprogrammed manually using the Evolution Control or the Bryant Service Tech App.

Code 88-31 VFD Internal Fault - Current Sensor**Code 88-71 VFD Lockout - Comp Current Sensor**

The VFD measures the compressor current value internally. If the compressor current measurement is not reported to VFD, it will shut down and attempt a restart after 5 minute compressor protection timer expires. Operating VFD without monitoring compressor current may result in compressor damage. Three occurrences of code 88-31 within a 4 hour period will result in 88-71 malfunction and 4 hour lockout. While this fault or malfunction is active the unit is inoperable. This malfunction, once set, is unlikely to go away and indicates VFD damage. Manually power cycle outdoor unit with disconnect, if malfunction persists replace VFD.

Code 88-32 VFD Internal Fault - IPM Temp Sens

The VFD has internal temperature sensors to monitor critical power components and take action if operating temperatures cross thresholds that may shorten the VFDs operating life. If the IPM temperature sensor fails it will no longer be capable of preventing the IPM module from operation above the safe reliable temperature threshold. If this fault is active the VFD will continue to operate normally, since the only way to correct this fault is to replace VFD.

Code 88-33 VFD Internal Fault - DC Link Sensor**Code 88-73 VFD Lockout - DC Link Sensor**

The VFD measures the DC voltage value internally. If the DC voltage measurement is not within acceptable operating parameters the VFD will shut down and attempt a restart after 5 minute compressor protection timer expires. Three occurrences of code 88-33 within a 4 hour period will result in 88-73 malfunction and 4 hour lockout. While this fault or malfunction is active the unit is inoperable. This malfunction, once set, is unlikely to go away and indicates VFD damage. Manually power cycle outdoor unit with disconnect, if malfunction persists replace VFD.

Code 88-34 VFD Internal Fault - PFCM Sensor A**Code 88-74 VFD Lockout - PFCM Sensor A**

The VFD has internal current measurement to protect PFC components from exceeding current thresholds that may shorten the VFDs operating life. If the PFCM Sensor A exceeds safe reliable value, the VFD will shut down immediately and attempt a restart after 5 minute compressor protection timer expires. Three occurrences of code 88-34 within a 4 hour period will result in 88-74 malfunction and 4 hour lockout. While this fault or malfunction is active the unit is inoperable. This malfunction, once set, is unlikely to go away and indicates VFD damage. Manually power cycle outdoor unit with disconnect, if malfunction persists replace VFD.

Code 88-35 VFD Internal Fault - PFCM Sensor B**Code 88-75 VFD Lockout - PFCM Sensor B**

The VFD has internal current measurement to protect PFC components from exceeding current thresholds that may shorten the VFDs operating life. If the PFCM Sensor B exceeds safe reliable value, the VFD will shut down immediately and attempt a restart after 5 minute compressor protection timer expires. Three occurrences of code 88-35 within a 4 hour period will result in 88-75 malfunction and 4 hour lockout. While this fault or malfunction is active the unit is inoperable. This malfunction, once set, is unlikely to go away and indicates VFD damage. Manually power cycle outdoor unit with disconnect, if malfunction persists replace VFD.

Code 88-36 VFD Internal Fault - Line Volt Sens**Code 88-76 VFD Lockout - Line Volt Sensor**

The VFD has internal voltage measurement to protect components from operating outside of voltage thresholds that may shorten the VFDs operating life. If the line volt sensor value is outside of safe reliable range, the VFD will shut down immediately and attempt a restart after 5 minute compressor protection timer expires. Three occurrences of code 88-36 within a 4 hour period will result in 88-76 malfunction and 4 hour lockout. While this fault or malfunction is active the unit is inoperable. This malfunction, once set, is unlikely to go away and indicates VFD damage. Manually power cycle outdoor unit with disconnect, if malfunction persists replace VFD.

Code 88-37 VFD Internal Fault - PFCM Temp Sens

The VFD has internal temperature sensors to monitor critical power components and take action if operating temperatures cross thresholds that may shorten the VFDs operating life. If the PFCM temperature sensor fails it will no longer be capable of preventing the PFC circuit from operation above the safe reliable temperature threshold. If this fault is active the VFD will continue to operate normally, since the only way to correct this fault is to replace VFD.

Code 88-38 VFD Internal Fault - DC Discharge**Code 88-78 VFD Lockout - Int DC Discharge**

The unit VFD converts boosts 230VAC line voltage and then converts to DC voltage before switching the DC voltage on and off rapidly to create a 3 phase waveform and operate compressor at varying speeds. This fault becomes active when the DC voltage is shorted to ground and the VFD will open the power relay. While this fault or malfunction is active the unit is inoperable. The VFD will attempt to reset itself automatically but if problem persists, the fault will escalate to 88-78 malfunction and lock out system for 4 hours. Manually power cycle outdoor unit with disconnect, if malfunction persists replace VFD.

Code 88-39 VFD Internal Fault - Microprocessor**Code 88-79 VFD Internal Lockout - Microprocessor**

This VFD has internal diagnostics to verify that the microprocessor is operating sufficiently to maintain safe compressor and fan operation. If the microprocessor detects any abnormal condition that could result in unsafe operation it will set a diagnostic code. If this occurs, the PCM will set 88-39 and reset the VFD to attempt to remedy the condition. If this attempt is unsuccessful, malfunction Code 88-79 will be set and the system will be locked out for 4 hours. Manually power cycle the outdoor system. If the diagnostic code persists replace the VFD.

Table 7 – Fault Code Table

Code*			Description
Base	Expansion		
	Fault**	Malfunction***	
13	82	53	System Control Software Upgrade Needed
14	94		Line Voltage Low
15	94		Line Voltage High
17	06		PCM-Bluetooth Module Communication Failure
18	11		Indoor Coil Freeze Protection
24		58	5V PCM External Power Out of Range
25		61	Invalid Model Plug
	22	62	Model Plug Missing
	24		Model Plug Changed
		63	VFD/Equipment Model Mismatch
26	26		PCM MCU Old Version
	27		PCM Reprogramming Failure
	31		EEPROM Write Failure
28		71	Fuse 1 Open (PEV / RVS)
		72	Fuse 2 Open (LLV)
31	11	58	Compressor High Pressure Limit
	16		High Pressure Switch Trip
	19		High Pressure Disable
32	15	55	Compressor Low Pressure Limit
		59	Low Pressure Disable
33	15	55	Compressor Low Discharge Limit
34	11	58	Compressor High Temperature Limit
35	11	58	Compressor High Compression Limit
36	15	55	Compressor Low Compression Limit
38	13	53	Compressor Starting Error
		54	Compressor No Pump
	18		High Differential Pressure Start Disable
	31	71	VFD Estimator Error
39	13	53	Fan Start Error
	14		Fan Speed Error
	15	55	Unexpected Fan Shutdown
		58	Fan Motor Error
41	13		Defrost Overrun
44	13		PEV Timeout
51	01		OAT (Outdoor Air Thermistor) Open/Low Temp
	02		OAT (Outdoor Air Thermistor) Shorted/High Temp
52	01		OCT (Outdoor Coil Thermistor) Open/Low Temp
	02		OCT (Outdoor Coil Thermistor) Shorted/High Temp
53		41	OST (Outdoor Suction Thermistor) Open/Low Temp
		42	OST (Outdoor Suction Thermistor) Shorted/High Temp
54	01		ODT (Outdoor Discharge Thermistor) Open/Low Temp
	02		ODT (Outdoor Discharge Thermistor) Shorted/High Temp
57	01	41	P1 Open
	02	42	P1 Shorted
		43	P1 Sensor Error
58	01	41	P2 Open
	02	42	P2 Shorted
		43	P2 Sensor Error
61		41	Reversing Valve Solenoid Open
61	13	53	Reversing Valve Timeout
62	01		PEV Solenoid Open

Manufacturer reserves the right to change, at any time, specifications and designs without notice and without obligations.

Table 7 – Fault Code Table (Continued)

Code*			Description
Base	Expansion		
	Fault**	Malfunction***	
64		41	EXV-H Phase Open
		44	EXV-H Power Short to Ground
		45	EXV-H Phase Short to Ground
65		41	EXV-VI Phase Open
		44	EXV-VI Power Short to Ground
		45	EXV-VI Phase Short to Ground
66		41	VFD Control Relay Coil Open
		42	VFD Control Relay Coil Shorted
81	13	53	PFC Error
	14	54	Unbalanced PFCM Error
		58	VFD System Wiring Error
82	11		VFD Line Current Speed Reduction
	13	53	VFD Reset with Power Dropout
	15	55	VFD Shutdown with Power Dropout
	16	56	Low Voltage Shutdown
	17	57	High Voltage Shutdown
83	11		Compressor Current Limit 1 Speed Reduction
	12		Compressor Current Limit 2 Speed Reduction
	15	55	Compressor Current Limit 3 Shutdown
	16	56	Compressor Current Limit 4 Shutdown
		57	Compressor Underspeed Shutdown
84	11	58	VFD Heat Sink Overtemp Shutdown
85	13	53	DC Under Voltage Shutdown
	14	54	DC Over Voltage Shutdown
86	06	46	VFD Communication Error
87	13	53	VFD Initialization Error
88	15	55	Unexpected VFD Reset
	27		VFD Reprogramming Failure
	31	71	VFD Internal Error - Current Sensor
	32		VFD Internal Error - IPM Temp Sensor
	33	73	VFD Internal Error - DC Link Sensor
	34	74	VFD Internal Error - PFCM Sensor A
	35	75	VFD Internal Error - PFCM Sensor B
	36	76	VFD Internal Error - Line Volt Sensor
	37		VFD Internal Error - PFCM Temp Sensor
	38	78	VFD Internal Error - DC Discharge Following
	39	79	VFD Internal Error - Microprocessor

*Code is reported by the thermostat



Fig. 19 – 2T/3T Control Box

A200187



Fig. 20 – 4T/5T Control Box

A200188

Note: 4T VFD similar, not exact. 5T reactors have additional chokes to meet FCC requirement

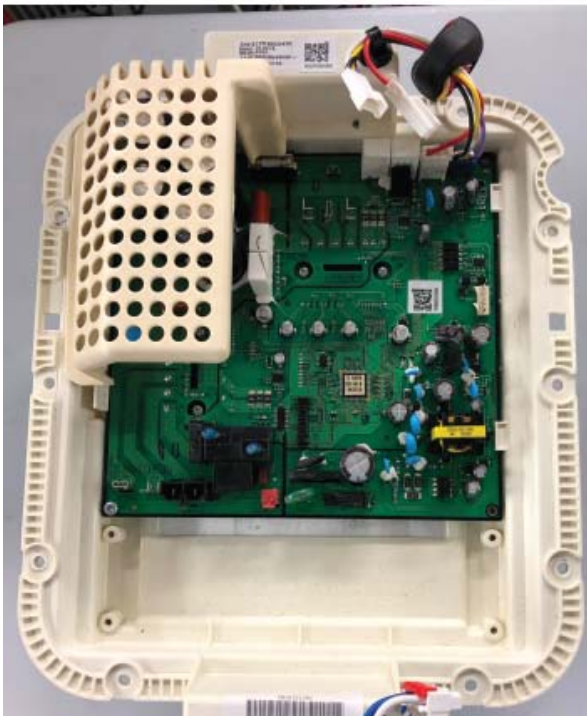

Fig. 21 – 2T/3T VFD

A200189



Fig. 22 – 4/5T VFD 5T VFD shown (4T VFD similar but not exact)

A200190

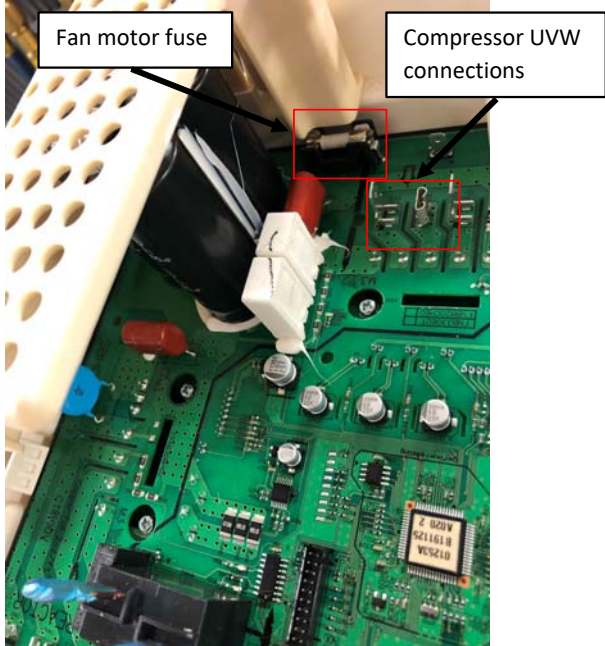
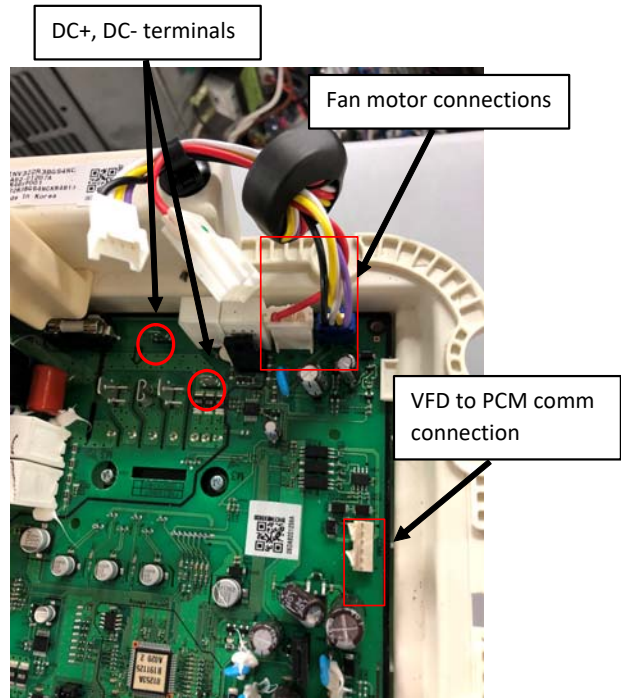
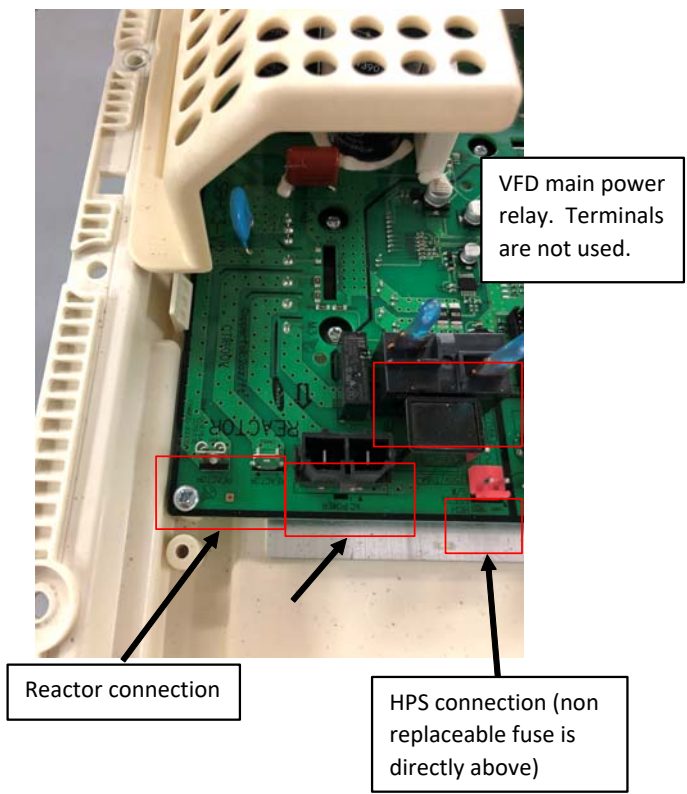

Fig. 23 – 2/3T VFD Connections

A200191

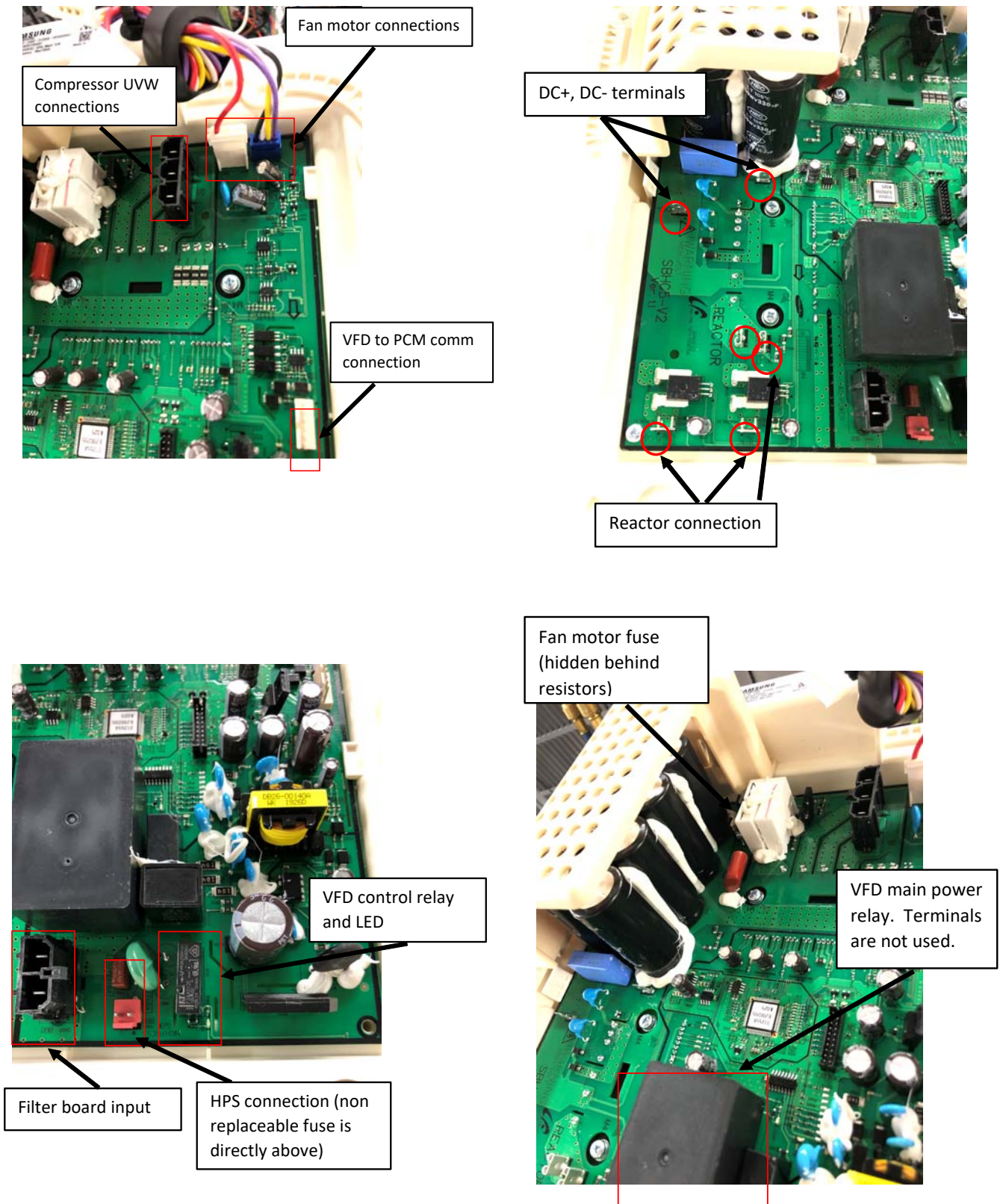

Fig. 24 – 4/5T VFD Connections
Note: 4T uses separate terminals

A200192

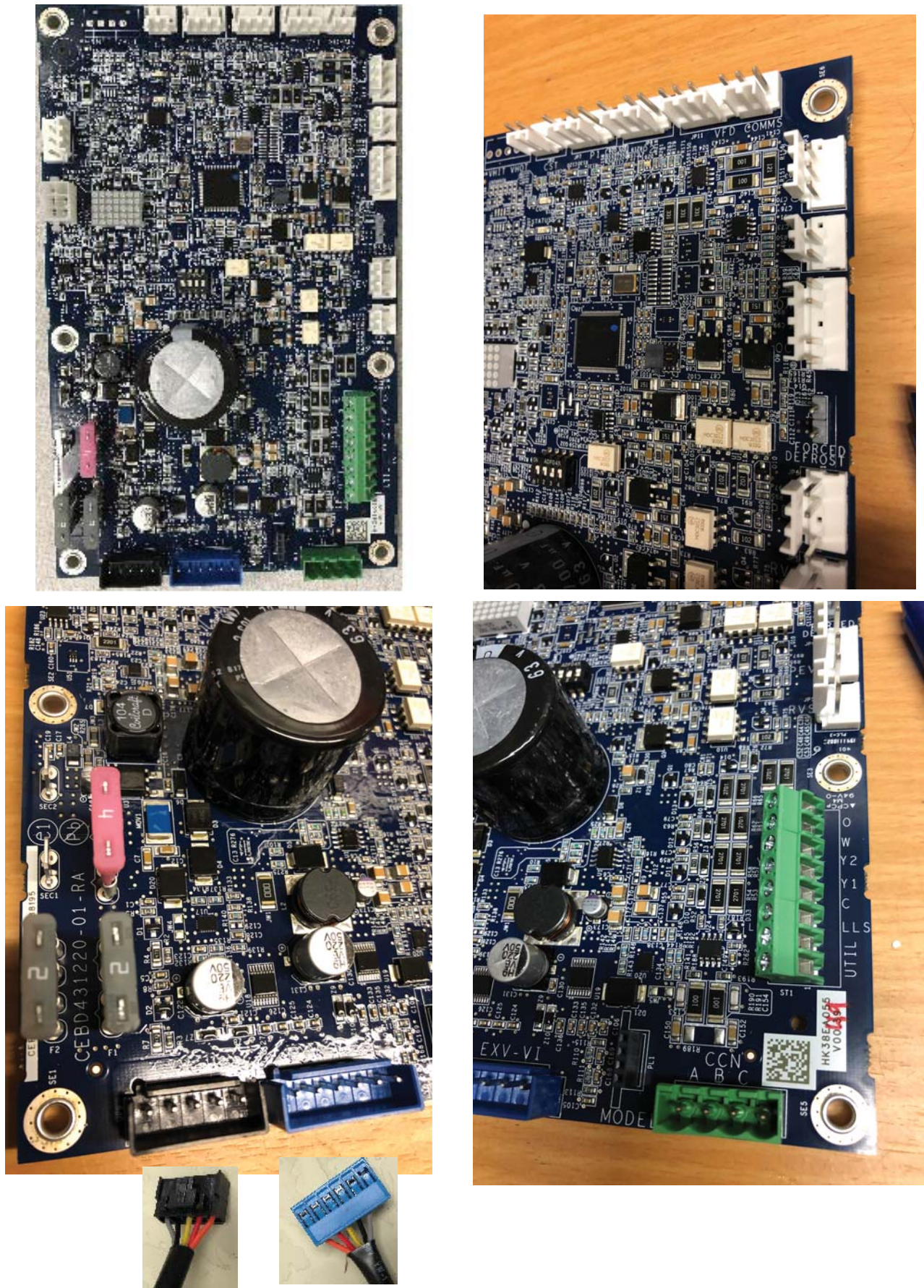

Fig. 25 – PCM (used on all models)

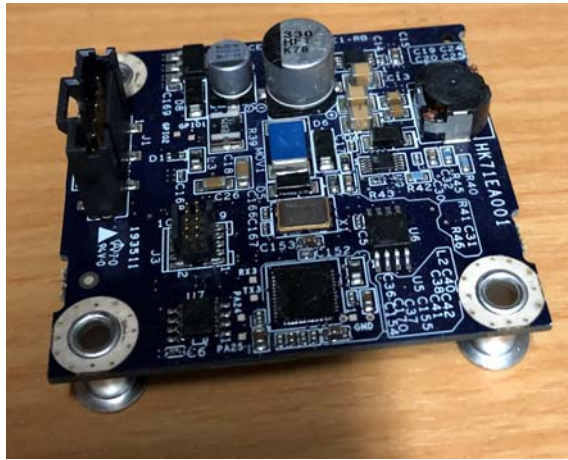

Fig. 26 – Bluetooth Module (used on all models)

A200194



Fig. 27 – Fan Motor (used on all models)

A200195



Fig. 29 – 5T Reactor (Note: 5T uses 2 reactors)

A200197

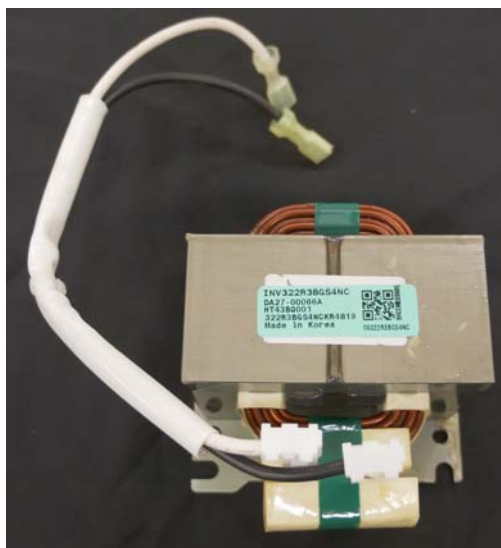

Fig. 28 – 2/3/4T Reactor
(Note: 4Tuses 2 reactors)

A200196

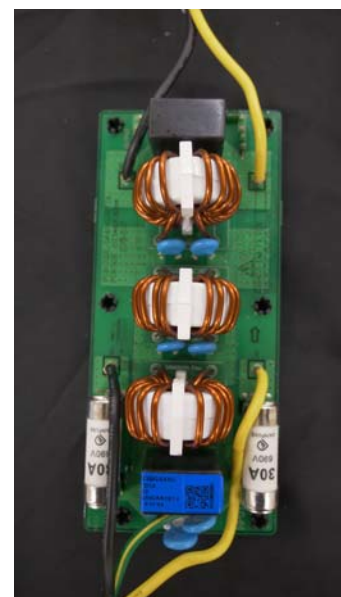

Fig. 30 – Filter Input Board (used on all models)

A200198

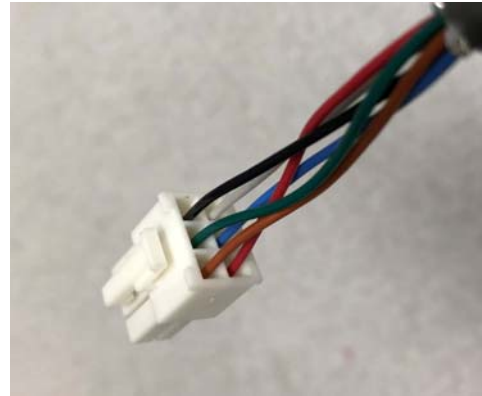
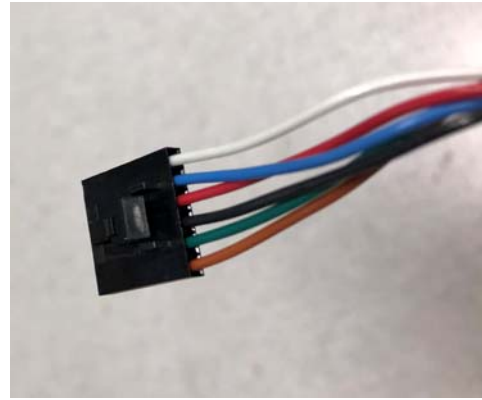

Fig. 31 – PCM to Bluetooth Module Comm Cable (used on all models)

A200199



Fig. 32 – VFD to PCM Comm Cable (used on all models)

A200200

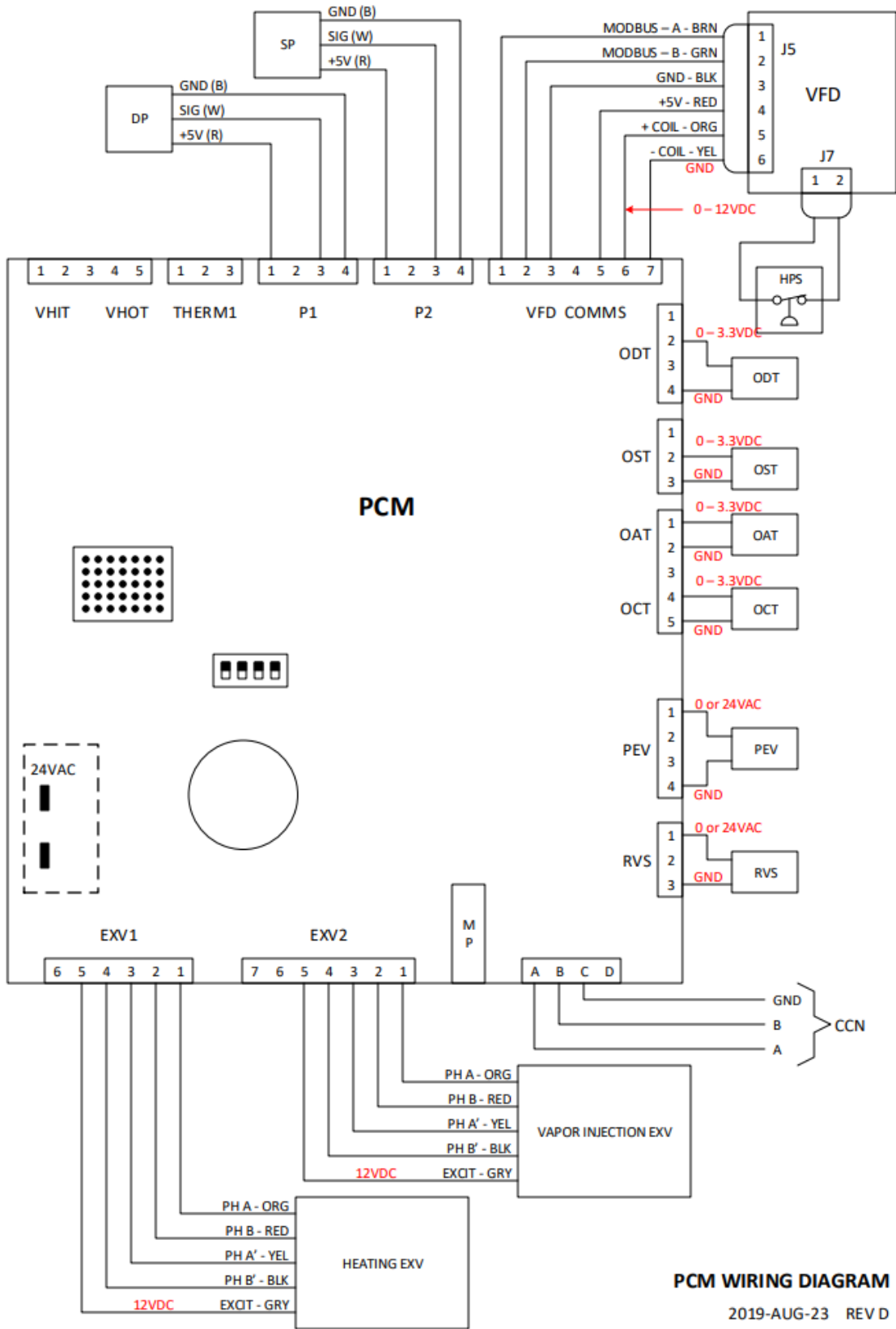

PCM WIRING DIAGRAM

2019-AUG-23 REV D

Fig. 33 – PCM Wiring Diagram

A200201

REFRIGERATION SYSTEM

Refrigerant

WARNING

UNIT OPERATION AND SAFETY HAZARD

Failure to follow this warning could result in personal injury or equipment damage.

Puron refrigerant which has higher pressures than R-22 and other refrigerants. No other refrigerant may be used in this system. Gauge set, hoses, and recovery system must be designed to handle Puron. If you are unsure consult the equipment manufacturer.

In an air conditioning and heat pump system, refrigerant transfers heat from one place to another. The condenser is the outdoor coil in the cooling mode and the evaporator is the indoor coil.

In a heat pump, the condenser is the indoor coil in the heating mode and the evaporator is the outdoor coil.

In the typical air conditioning mode, compressed hot gas leaves the compressor and enters the condensing coil. As gas passes through the condenser coil, it rejects heat and condenses into liquid. The liquid leaves condensing unit through liquid line and enters metering device at evaporator coil. As it passes through metering device, it becomes a gas-liquid mixture. As it passes through indoor coil, it absorbs heat and the refrigerant moves to the compressor and is again compressed to hot gas, and cycle repeats.

Compressor Oil

CAUTION

UNIT DAMAGE HAZARD

Failure to follow this caution may result in equipment damage or improper operation.

The compressor in a Puron system uses a polyvinyl ether (PVE) oil. This oil is extremely hygroscopic, meaning it absorbs water readily. PVE oils can absorb 15 times as much water as other oils designed for HCFC and CFC refrigerants. Take all necessary precautions to avoid exposure of the oil to the atmosphere.

Servicing Systems on Roofs With Synthetic Materials

Polyvinyl ether (PVE) compressor lubricants are known to cause long term damage to some synthetic roofing materials. Exposure, even if immediately cleaned up, may cause embrittlement (leading to cracking) to occur in one year or more. When performing any service which may risk exposure of compressor oil to the roof, take appropriate precautions to protect roofing. Procedures which risk oil leakage include but are not limited to compressor replacement, repairing refrigerants leaks, replacing refrigerant components such as filter drier, pressure switch, metering device, coil, accumulator, or reversing valve.

Synthetic Roof Precautionary Procedure

1. Cover extended roof working area with an impermeable polyethylene (plastic) drop cloth or tarp. Cover an approximate 10 x 10 ft area.
2. Cover area in front of the unit service panel with a terry cloth shop towel to absorb lubricant spills and prevent run-offs, and protect drop cloth from tears caused by tools or components.
3. Place terry cloth shop towel inside unit immediately under component(s) to be serviced and prevent lubricant run-offs through the louvered openings in the base pan.
4. Perform required service.
5. Remove and dispose of any oil contaminated material per local codes.

Brazing

This section on brazing is not intended to teach a technician how to braze. There are books and classes which teach and refine brazing techniques. The basic points below are listed only as a reminder.

Definition: The joining and sealing of metals using a nonferrous metal having a melting point over 800°F/426.6°C.

Flux: A cleaning solution applied to tubing or wire before it is brazed. Flux improves the strength of the brazed connection.

When brazing is required in the refrigeration system, certain basics should be remembered. The following are a few of the basic rules.

1. Clean joints make the best joints. To clean:
 - Remove all oxidation from surfaces to a shiny finish before brazing.
 - Remove all flux residue with brush and water while material is still hot.
2. Silver brazing alloy is used on copper-to-brass, copper-to-steel, or copper-to-copper. Flux is required when using silver brazing alloy. Do not use low temperature solder.
3. Fluxes should be used carefully. Avoid excessive application and do not allow fluxes to enter into the system.
4. Brazing temperature of copper is proper when it is heated to a minimum temperature of 800°F and it is a dull red color in appearance.

Service Valves and Pumpdown

WARNING

PERSONAL INJURY AND UNIT DAMAGE HAZARD

Failure to follow this warning could result in personal injury or equipment damage.

Never attempt to make repairs to existing service valves. Unit operates under high pressure. Damaged seats and o-rings should not be replaced. Replacement of entire service valve is required. Service valve must be replaced by properly trained service technician.

Service valves provide a means for holding original factory charge in outdoor unit prior to hookup to indoor coil. They also contain gauge ports for measuring system pressures and provide shutoff convenience for certain types of repairs.

The service valve is a front-seating valve, which has a service port that contains a Schrader fitting. The service port is always pressurized after the valve is moved off the front-seat position.

The service valves in the outdoor unit come from the factory front-seated. This means that the refrigerant charge is isolated from the line-set connection ports. The interconnecting tubing (line set) can be brazed to the service valves using industry accepted methods and materials. Consult local codes.

Before brazing the line set to the valve, the belled ends of the sweat connections on the service valves must be cleaned so that no brass plating remains on either the inside or outside of the bell joint. To prevent damage to the valve and/or cap "O" ring, use a wet cloth or other acceptable heat-sinking material on the valve before brazing. To prevent damage to the unit, use a metal barrier between brazing area and unit.

After the brazing operation and the refrigerant tubing and evaporator coil have been evacuated, the valve stem can be turned counterclockwise until back-seats, which releases refrigerant into tubing and evaporator coil. The system can now be operated.

The service valve-stem cap is tightened to 20 ± 2 ft/lb torque and the service-port caps to 9 ± 2 ft/lb torque. The seating surface of the valve stem has a knife-set edge against which the caps are tightened to attain a metal-to-metal seal.

The service valve cannot be field repaired; therefore, only a complete valve or valve stem and service-port caps are available for replacement. If the service valve is to be replaced, a metal barrier must be inserted between the valve and the unit to prevent damaging the unit exterior from the heat of the brazing operations.

! CAUTION

PERSONAL INJURY HAZARD

Failure to follow this caution may result in personal injury. Wear safety glasses, protective clothing, and gloves when handling refrigerant.

Pumpdown & Evacuation

If this system requires either a Pump Down or Evacuation for any reason, the procedures below must be followed:

Pump Down

Because this system has an inverter controlled, compressor, suction pressure transducer and EXV, conventional procedure cannot be used to "pump down" and isolate the refrigerant into the outdoor unit. The UI (User Interface) has provisions to assist in performing this function.

1. Connect gages to outdoor unit liquid and vapor or suction capillary service ports to monitor operating pressures during and at completion of the procedure.
2. In the "installation and service" menu of the wall control, go to "refrigerant charging" and then "pump down"
3. Select mode to pump down in (COOL or HEAT), COOL mode allows refrigerant to be isolated in outdoor unit. HEAT mode allows the refrigerant to be isolated in indoor coil and lineset. Set desired time period. Default time period for the procedure is 120 minutes.
4. Select "Start" on wall control to begin the pumpdown process. Unit will begin running in selected mode after a brief delay and a status screen will be displayed.
5. Close the liquid service valve.
6. The unit will run in selected mode with the low pressure protection set to indicate pumpdown is complete when the suction pressure drops below 20 psig. Compressor protections are still active to prevent damage to the compressor or inverter (high pressure, high current, etc.).
7. Once system indicates pumpdown complete or failure to complete shutdown, close vapor service valve.
8. A recovery system will be required to remove final quantity of refrigerant from indoor coil and line set.
9. Remove power from indoor and outdoor unit prior to servicing unit.

NOTE: A small quantity of charge remains in the OD unit that must be manually recovered if isolating refrigerant to indoor coil and lineset via HEAT mode PUMP DOWN.

Evacuation and Recovery of Refrigerant from 284ANV

! CAUTION

ENVIRONMENTAL HAZARD

Failure to follow this caution may result in environmental damage. Federal regulations require that you do not vent refrigerant to the atmosphere. Recover during system repair or final unit disposal.

NOTE: All outdoor unit coils will hold only factory-supplied amount of refrigerant. Excess refrigerant, such as in long-line applications, may cause unit to relieve pressure through internal pressure-relief valve (indicated by sudden rise of suction pressure) before suction pressure reaches 5 psig (35kPa). If this occurs, shut unit off immediately, front seat suction valve, and recover remaining pressure. connection to the suction port of the compressor.

Reversing Valve (284ANV)

In heat pumps, changeover between heating and cooling modes is accomplished with a valve that reverses flow of refrigerant in system. This reversing valve device is easy to troubleshoot and replace. The reversing valve solenoid can be checked with power off with an ohmmeter. Check for continuity and shorting to ground. With control circuit (24v) power on, check for correct voltage at solenoid coil. Check for overheated solenoid.

NOTE: Reversing valve diagnostic can only detect an open coil when reversing valve is not energized, thus a damaged coil during cooling operation will not trigger diagnostic. In this case the HP will operate in heating mode when wall controller is requesting cooling operation. Manual troubleshooting of coil will be required to confirm failure.

With unit operating, other items can be checked, such as frost or condensate water on refrigerant lines.

The sound made by a reversing valve as it begins or ends defrost is a "whooshing" sound, as the valve reverses and pressures in system equalize. An experienced service technician detects this sound and uses it as a valuable troubleshooting tool.

Using a remote measuring device, check inlet and outlet line temperatures. DO NOT touch lines. If reversing valve is operating normally, inlet and outlet temperatures on appropriate lines should be close to each other. Any difference would be due to heat loss or gain across valve body. Temperatures are best checked with a remote reading electronic-type thermometer with multiple probes. Route thermocouple leads to inside of coil area through service valve mounting plate area underneath coil. Fig. 34 and Fig. 35 show test points (TP) on reversing valve for recording temperatures. Insulate points for more accurate reading. If valve is defective:

1. Shut off all power to unit and remove charge from system.
2. Remove solenoid coil from valve body. Remove valve by cutting it from system with tubing cutter. Repair person should cut in such a way that stubs can be easily re-brazed back into system. Do not use hacksaw. This introduces chips into system that cause failure. After defective valve is removed, wrap it in wet rag and carefully unbrazed stubs. Save stubs for future use. Because defective valve is not overheated, it can be analyzed for cause of failure when it is returned.
3. Braze new valve onto used stubs. Keep stubs oriented correctly. Scratch corresponding matching marks on old valve and stubs and on new valve body to aid in lining up new valve properly. When brazing stubs into valve, protect valve body with wet rag to prevent overheating.
4. Use slip couplings to install new valve with stubs back into system. Even if stubs are long, wrap valve with a wet rag to prevent overheating.
5. After valve is brazed in, check for leaks. Evacuate and charge system. Operate system in both modes several times to be sure valve functions properly.

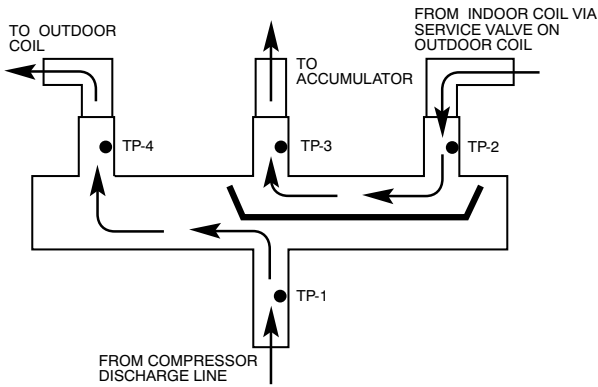

**Fig. 34 – Reversing Valve
(Cooling mode or defrost mode, solenoid energized)**

A88342

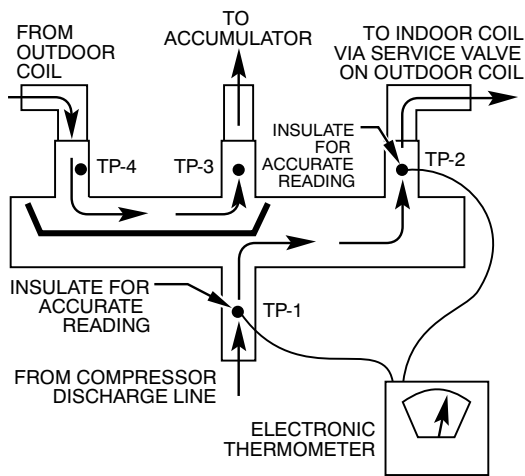

**Fig. 35 – Reversing Valve
(Heating Mode, solenoid de-energized)**

A88341

Liquid Line Filter Drier

Filter driers are specifically designed for R-22 or Puron refrigerant. Only operate with the appropriate drier using factory authorized components.

It is recommended that the liquid line drier be installed at the indoor unit for all models except 5 Ton. Since the potential of refrigerant line pulsations from vapor injection exists, install 5 Ton filter drier at outdoor unit. Not all applications will experience this pulsation.

! CAUTION

UNIT DAMAGE HAZARD

Failure to follow this caution may result in equipment damage or improper operation.

To avoid performance loss and compressor failure, installation of filter drier in liquid line is required.

! CAUTION

UNIT DAMAGE HAZARD

Failure to follow this caution may result in equipment damage or improper operation.

To avoid filter drier damage while brazing, filter drier must be wrapped in a heat-sinking material such as a wet cloth.

Install Liquid-line Filter Drier Indoor

Refer to Fig. 36 or Fig. 37 and install filter drier as follows:

1. Braze 5 in. liquid tube to the indoor coil.
2. Wrap filter drier with damp cloth.
3. Braze filter drier to 5 in. long liquid tube from step 1.
4. Connect and braze liquid refrigerant tube to the filter drier.

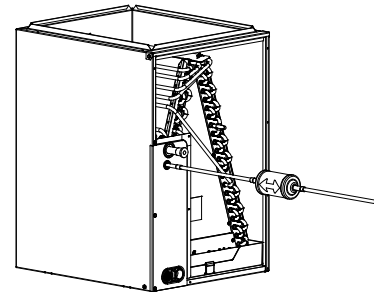

Fig. 36 – Liquid Line Filter Drier - 2/3/4T Applications

A05227

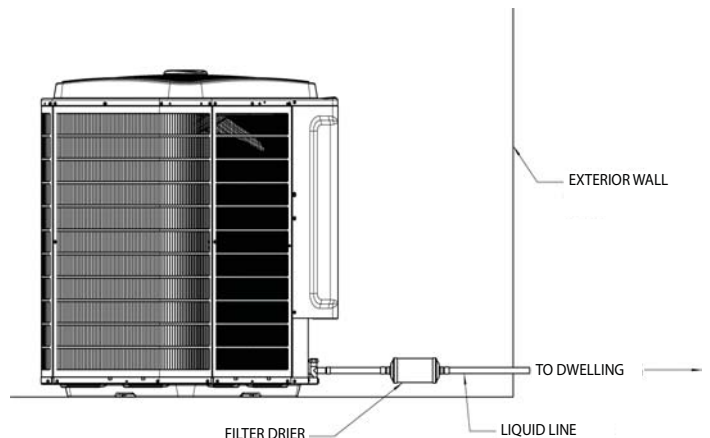

Fig. 37 – Liquid Line Filter Drier for 5 Ton Applications

A200082

Suction Line Filter Drier

The suction line drier is specifically designed to operate with Puron® Refrigerant, use only factory authorized components. Suction line filter drier is used in cases where acid might occur, such as burnout. Heat pump units must have the drier installed between the compressor and accumulator only. Remove after 10 hours of operation. Never leave suction line filter drier in a system longer than 72 hours (actual time).

Thermostatic Expansion Valve (TXV)

All fan coils and furnace coils will have a factory installed thermostatic expansion valve (TXV). The TXV will be a bi-flow, hard-shutoff with an external equalizer and a balance port pin. A hard shut-off TXV does not have a bleed port. Therefore, minimal equalization takes place after shutdown. TXVs are specifically designed to operate with Puron® or R-22 refrigerant, use only factory authorized TXV's. **Do not interchange Puron and R-22 TXVs.**

TXV Operation

The TXV is a metering device that is used in air conditioning and heat pump systems to adjust to changing load conditions by maintaining a preset superheat temperature at the outlet of the evaporator coil. The volume of refrigerant metered through the valve seat is dependent upon the following:

1. Superheat temperature is sensed by cap tube sensing bulb on suction tube at outlet of evaporator coil. This temperature is converted into pressure by refrigerant in the bulb pushing downward on the diaphragm which opens the valve via the push rods.
2. The suction pressure at the outlet of the evaporator coil is transferred via the external equalizer tube to the underside of the diaphragm. This is needed to account for the indoor coil pressure drop. Residential coils typically have a high pressure drop, which requires this valve feature.
3. The pin is spring loaded, which exerts pressure on the underside of the diaphragm. Therefore, the bulb pressure works against the spring pressure and evaporator suction pressure to open the valve. If the load increases, the temperature increases at the bulb, which increases the pressure on the top side of the diaphragm. This opens the valve and increases the flow of refrigerant. The increased refrigerant flow causes the leaving evaporator temperature to decrease. This lowers the pressure on the diaphragm and closes the pin. The refrigerant flow is effectively stabilized to the load demand with negligible change in superheat.

Accumulator

The accumulator is specifically designed to operate with Puron® or R22 respectfully; use only factory-authorized components. Under some light load conditions on indoor coils, liquid refrigerant is present in suction gas returning to compressor. The accumulator stores liquid and allows it to boil off into a vapor so it can be safely returned to compressor. Since a compressor is designed to pump refrigerant in its gaseous state, introduction of liquid into it could cause severe damage or total failure of compressor.

The accumulator is a passive device which seldom needs replacing. Occasionally its internal oil return orifice or bleed hole may become plugged. Some oil is contained in refrigerant returning to compressor. It cannot boil off in accumulator with liquid refrigerant. The bleed hole allows a small amount of oil and refrigerant to enter the return line where velocity of refrigerant returns it to compressor. If bleed hole plugs, oil is trapped in accumulator, and compressor will eventually fail from lack of lubrication. If bleed hole is plugged, accumulator must be changed. The accumulator has a fusible element located in the bottom end bell. (See Fig. 38.) This fusible element will melt at 430°F//221°C and vent the refrigerant if this temperature is reached either internal or external to the system. If fuse melts, the accumulator must be replaced.

To change accumulator:

1. Shut off all power to unit.
2. Recover all refrigerant from system.
3. Break vacuum with dry nitrogen. Do not exceed 5 psig.

NOTE: Coil may be removed for access to accumulator. Refer to appropriate sections of Service Manual for instructions.

! CAUTION

PERSONAL INJURY HAZARD

Failure to follow this caution may result in personal injury. Wear safety glasses, protective clothing, and gloves when handling refrigerant.

4. Remove accumulator from system with tubing cutter.
5. Tape ends of open tubing.

6. Scratch matching marks on tubing studs and old accumulator. Scratch matching marks on new accumulator. Unbraze stubs from old accumulator and braze into new accumulator.
7. Thoroughly rinse any flux residue from joints and paint with corrosion-resistant coating such as zinc-rich paint.
8. Install factory authorized accumulator into system with copper slip couplings.
9. Evacuate and charge system.

Pour and measure oil quantity (if any) from old accumulator. If more than 20 percent of oil charge is trapped in accumulator, add new PVE oil to compressor to make up for this loss.

! WARNING

ELECTRICAL SHOCK HAZARD

Failure to follow this warning could result in personal injury or death. Before installing, modifying, or servicing system, main electrical disconnect switch must be in the OFF position. There may be more than 1 disconnect switch. Lock out and tag switch with a suitable warning label.

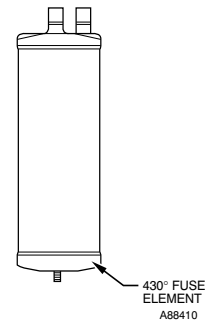

Fig. 38 – Accumulator

A88410

Vapor Injection Operation (5 Ton Models)

Some 284ANV and 186CNV models contain an additional refrigeration circuit known as a vapor injection circuit. When active this circuit will increase the capacity of the outdoor unit with a minimal increase in power consumption. The result is higher capacity at a higher efficiency. This circuit is only active at extreme heating and cooling temperatures and only in efficiency mode.

The vapor injection circuit routes a portion of the subcooled liquid from the condenser through a vapor injection EXV (EXV-VI) and into a brazed-plate heat exchanger (BPHX) The resulting superheated vapor will return to the compressor and be "injected" into the mid port. Meanwhile subcooled liquid leaving the condenser is routed through the other portion of the BPHX and is further subcooled before exiting to the evaporator section of system, thus improving the capacity.

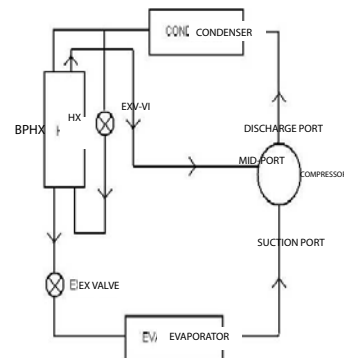

Fig. 39 – Vapor Injection Operation

A200183

Vapor Injection Electronic Exp. Valve (EXV VI) (5 Ton Models)

The EXV-VI is an electronically controlled needle valve for regulating refrigerant flow during heating operation. The EXV-VI is driven by a 12VDC, 2-phase, uni-polar stepper motor. The EXV-VI has a 475 step range between fully closed and fully open. The PCM drives the EXV at a rate of 77 steps per second. The PCM initializes the EXV-VI to the closed position when power is applied to the equipment. This process takes approximately 7 seconds.

When operating at full capacity in a cooling at high ambient temperatures or in heating at low ambient temperatures in efficiency mode, the EXV-VI is actively controlled to maintain discharge super heat to a control target value. When operating at a lower capacity, in comfort mode, at mild ambient temperatures, or not running, the EXV-VI is closed.

The brazed plate heat exchanger assembly is mounted to the base pan using a grommet and stud similar to the accumulator mounting. The BPHE assembly also contains a muffler either between the BPHE and the compressor or between the BPHE and the liquid service valve. Additionally, there are rubber dampers attached to the tube between the BPHE and the compressor.

If any part of the BPHE needs to be repaired then only a factory-authorized part shall be used to replace the entire vapor injection assembly. It is recommended that the coil be removed to replace the BPHE assembly. Upon replacement the grommet and clip used for mounting can be re-used and the dampers shall be re-attached to the BPHE assembly using a wire tie. Failure to re-attach the dampers could result in a premature tube failure."

REFRIGERATION SYSTEM REPAIR

Leak Detection

New installations should be checked for leaks prior to complete charging. If a system has lost all or most of its charge, system must be pressurized again to approximately 150 psi minimum and 375 psi maximum. This can be done by adding refrigerant using normal charging procedures or by pressurizing system with nitrogen (less expensive than refrigerant). Nitrogen also leaks faster than refrigerants. Nitrogen cannot, however, be detected by an electronic leak detector. (See Fig. 40.)

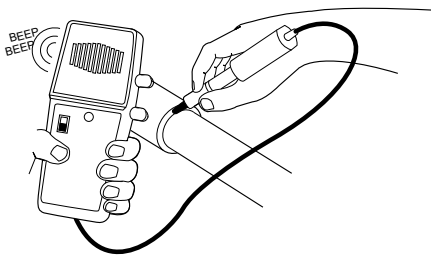

Fig. 40 – Electronic Leak Detection

A95422

! WARNING

PERSONAL INJURY AND UNIT DAMAGE HAZARD

Failure to follow this warning could result in personal injury or death. Due to the high pressure of nitrogen, it should never be used without a pressure regulator on the tank.

Assuming that a system is pressurized with either all refrigerant or a mixture of nitrogen and refrigerant, leaks in the system can be found with an electronic leak detector that is capable of detecting specific refrigerants.

If system has been operating for some time, first check for a leak visually. Since refrigerant carries a small quantity of oil, traces of oil at any joint or connection is an indication that refrigerant is leaking at that point.

A simple and inexpensive method of testing for leaks is to use soap bubbles. (See Fig. 41.) Any solution of water and soap may be used. Soap solution is applied to all joints and connections in system. A small pinhole leak is located by tracing bubbles in soap solution around leak. If the leak is very small, several minutes may pass before a bubble will form. Popular commercial leak detection solutions give better, longer-lasting bubbles and more accurate results than plain soapy water. The bubble solution must be removed from the tubing and fittings after checking for leaks as some solutions may corrode the metal.

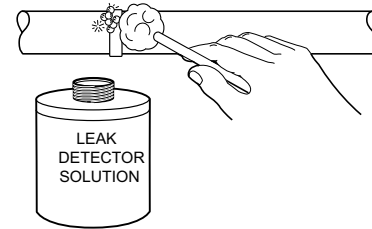

Fig. 41 – Bubble Leak Detection

A95423

You may use an electronic leak detector designed for specific refrigerant to check for leaks (See Fig. 40). This unquestionably is the most efficient and easiest method for checking leaks. There are various types of electronic leak detectors. Check with manufacturer of equipment for suitability. Generally speaking, they are portable, lightweight, and consist of a box with several switches and a probe or sniffer. Detector is turned on and probe is passed around all fittings and connections in system. Leak is detected by either the movement of a pointer on detector dial, a buzzing sound, or a light.

In all instances when a leak is found, system charge must be recovered and leak repaired before final charging and operation. After leak testing or leak is repaired, replace liquid line filter drier, evacuate system, and recharge with correct refrigerant quantity.

! WARNING

ELECTRICAL SHOCK HAZARD

Failure to follow this warning could result in personal injury or death. Before installing, modifying, or servicing system, main electrical disconnect switch must be in the OFF position. There may be more than 1 disconnect switch. Lock out and tag switch with a suitable warning label.

Coil Removal

Coils are easy to remove if required for compressor removal, or to replace coil.

1. Shut off all power to unit.
2. Recover refrigerant from system through service valves.
3. Break vacuum with nitrogen.
4. Remove top cover.
5. Remove screws in base pan to coil grille.
6. Remove coil grille from unit.
7. Remove screws on corner post holding coil tube sheet.

! WARNING

FIRE HAZARD

Failure to follow this warning could result in personal injury or equipment damage. Cut tubing to reduce possibility of personal injury and fire.

8. Use midget tubing cutter to cut liquid and vapor lines at both sides of coil. Cut in convenient location for easy reassembly with copper slip couplings.
9. Lift coil vertically from basepan and carefully place aside.
10. Reverse procedure to reinstall coil.
11. Replace filter drier, evacuate system, recharge, and check for normal systems operation.

Training

My Learning Center is your central location for professional residential HVAC training resources that help strengthen careers and businesses. We believe in providing high quality learning experiences both online and in the classroom.

Access My Learning Center with your HVACpartners credentials at www.mlctraining.com. Please contact us a mylearning@carrier.com with questions.

The Bluetooth® word mark and logos are registered trademarks owned by Bluetooth SIG, Inc. and any use of such marks by Bryant is under license. Other trademarks and trade names are those of their respective owners