

50ZPC, 50ZPD
Single-Packaged Air Conditioner System
with Puron® (R-410A) Refrigerant
Single Phase
2 to 5 Nominal Tons (Sizes 024-060)



Turn to the experts

Product Data

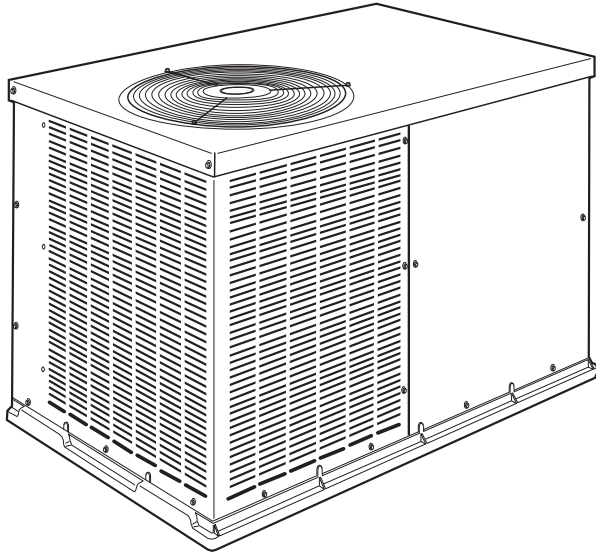

Fig. 1 – Unit 50ZPC, 50ZPD

A10165

This unit is a packaged air conditioner for manufactured housing, residential, and light commercial applications. The unit design is the result of our firm commitment to the development of the finest air conditioners that modern technology can offer.

The unit is built in one basic cabinet size and features a round or rectangular side-by-side duct configuration.

Features/Benefits

FACTORY-ASSEMBLED PACKAGE is a compact, fully self-contained, electric cooling unit with horizontal supply and return ducts. The unit is available in a variety of standard cooling sizes to meet residential and light commercial requirements. Unit installs easily on a ground level pad.

EASY TO INSTALL - The unit is small, compact, and easy to handle. Every unit has an identical 32 x 51-in. (813 x 1295 mm) footprint to make planning simple. The concise design uses less sheet metal and makes the unit lighter than other units. The unit can be easily positioned on the job site with the hand holds built into the unit basepan.

AERODYNAMIC FAN BLADE DESIGN reduces the overall sound now as low as 71dBA.

SERVICE ACCESS makes installation and maintenance quicker and easier. This unit is designed to be serviced from both the side and front. The design allows easy access for installation and maintenance procedures on the unit. Routine maintenance tasks such as coil cleaning are sped up with the multiple access side panels.

NO-RUST BASEPAN WITH INTEGRATED DRAIN PAN is standard on all units. The unit features a tough, hightech, composite material basepan with integrated drain pan. The composite material eliminates the potential problems of rust and premature replacement which are common with standard metal basepans.

DURABLE PRE-PAINTED STEEL CABINET protects against harsh weather. The watertight construction and corrosion-resistant finish will keep it looking like new for years. The paint treatment process ensures quality protection against the elements. A compact, low-profile design utilizes a louvered coil enclosure for protection against vandalism and hail damage.

INDOOR AIR QUALITY is designed into the unit. A sloped drain pan minimizes the amount of standing water inside the unit, which limits mold and mildew growth. The drain pan is made of a rust-proof material and will not deteriorate or release foreign matter into the airstream.

LIGHTWEIGHT, COMPACT CONSTRUCTION is ideal for manufactured housing and residential applications. This unit is one of the lightest, most compact packaged units ever designed. It's light weight (230 lb [104 kg] for the 024 size) makes the unit easier to handle. The low height keeps ductwork connections to a minimum and makes units less visible.

This unit utilizes a structural beam design to form the four sides of the cabinet. Only 12 different pieces of sheet metal are used in the unit construction to simplify the unit for greater reliability.

EFFICIENT, DEPENDABLE PERFORMANCE with durable compressors designed for efficiency. The unit offers up to 14.5 SEER (Seasonal Energy Efficiency Ratio) cooling performance efficiencies. This performance level can reduce cooling expenses by as much as 30% compared to older cooling equipment.

DURABLE, DEPENDABLE, COMPRESSORS are designed for high efficiency. Each compressor is hermetically sealed against contamination to help promote longer life and dependable operation. Vibration isolation provides quiet operation. Compressors have internal overcurrent protection.

DIRECT-DRIVE MULTISPEED, BLOWER MOTOR is standard on all models. It's high efficiency design ensures high performance with most duct systems.

DIRECT-DRIVE, PSC CONDENSER-FAN MOTORS are designed to help reduce energy consumption and provide for cooling operation down to 40°F (4.4°C).

REFRIGERANT SYSTEM is designed to provide dependability. Liquid refrigerant filter driers are used to promote clean, unrestricted operation. Each unit leaves the factory with a full refrigerant charge. Refrigerant service connections make checking operating pressures easier.

AIR HANDLING LEAKAGE—Cabinet air leakage less than 2.0% at 1.0 in. W.C. and cabinet air leakage less than 1.4% at 0.5 in W.C. when tested in accordance with ASHRAE standard 193

ACCESSORY ELECTRIC HEATERS — A variety of accessory electric heaters are available. These heaters are comprised of a separate heater module mounted on the blower inlet and remote mounted controls located in the unit control box. Single point electrical connections are available for powering both the heater and the unit.

Table of Contents

Features/Benefits	1	Selection Procedure	7
Model Number Nomenclature	2	Performance Data	8
Physical Data	3	Typical Connection Wiring Schematic.	13
Options and Accessories	4	Operating Sequence	17
Dimensional Drawing	5	Application Data	17
Dimensional Drawings	6	Guide Specifications.	18

Model Number Nomenclature

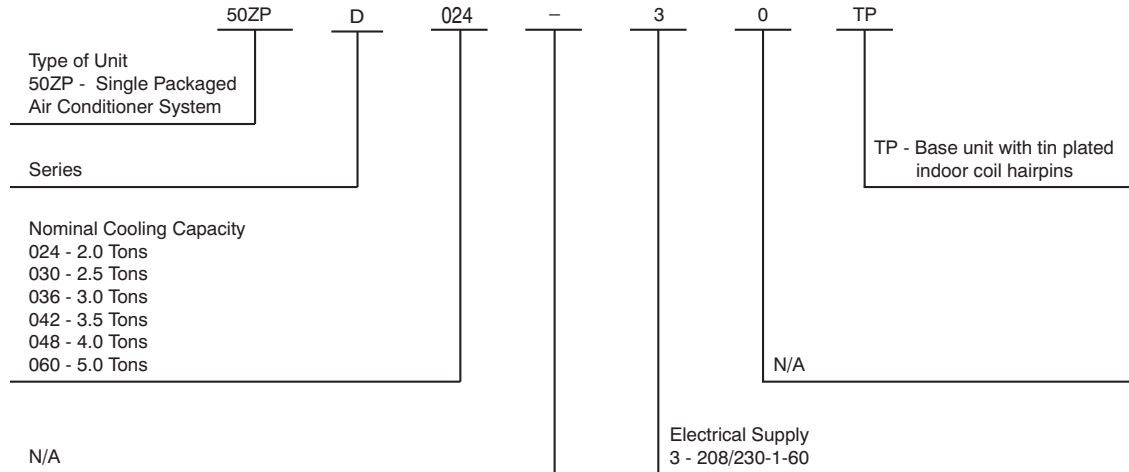

Use of the AHRI Certified TM Mark indicates a manufacturer's participation in the program. For verification of certification for individual products, go to www.ahridirectory.org.



AHRI* Capacity Ratings Cooling Capacities and Efficiencies

UNIT SIZE	NOMINAL TONS	STANDARD CFM	NET COOLING CAPACITY AT 95°F (35°C) (Btuh)	EER	SEER†
024	2	800	22400	11.5	14
030	2.5	1000	28600	11.5	14
036	3	1200	34200	11.5	14
042	3.5	1400	41000	11.5	14.5
048	4	1600	47000	11.5	14
060	5	1850	54000	11.3	14

*. Air Conditioning Heating & Refrigeration Institute

†. Rated in accordance with U.S. Government DOE Department of Energy) test procedures and/or AHRI Standards 210/240---08, 270-1995

LEGEND

SEER---Seasonal Energy Efficiency Ratio

COP---Coefficient of Performance

Notes:

1. Ratings are net values, reflecting the effects of circulating fan heat.
2. Before purchasing this appliance, read important energy cost and efficiency information available from your retailer.

A-Weighted Sound Power Level (dBA)

UNIT SIZE	STANDARD RATING (dBA*)	TYPICAL OCTAVE BAND SPECTRUM (dBA without tone adjustment)							
		125	250	500	1000	2000	4000	8000	
024	71	51.7	55.2	58.2	62.0	55.6	49.4	44.0	
030	73	60.4	56.6	61.7	64.0	57.4	54.9	46.4	
036	75	57.7	61.6	63.9	65.5	60.0	54.4	49.5	
042	77	64.8	68.3	72.9	72.2	68.2	62.6	53.1	
048	76	58.4	61.9	65.3	65.5	59.7	55.0	47.4	
060	80	72.9	65.4	68.8	70.5	65.2	60.5	50.9	

*. dBA - Sound Power Levels (decibels A-weighting)

NOTE: Tested in accordance with AHRI Standard 270-1995 (not listed in AHRI)

Physical Data

UNIT SIZE	024	030	036	042	048	060
NOMINAL CAPACITY (ton)	2	2.5	3	3.5	4	5
SHIPPING WEIGHT (lb)	286	298	329	352	368	402
(kg)	130	136	150	160	167	183
COMPRESSOR TYPE	SCROLL					
REFRIGERANT	R-410A					
REFRIGERANT QUANTITY (lb)	3.4	4.1	5.0	5.7	6.3	7.5
QUANTITY (kg)	1.54	1.86	2.27	2.59	2.86	3.4
METERING DEVICE ID	Piston					TXV
ORIFICE OD (in.)	0.057	0.063	0.073	0.076	0.080	N/A
(mm)	1.45	1.60	1.85	1.93	2.03	
OUTDOOR COIL						
ROWS...FINS/in.	1...20	1...20	2...20	2...20	2...20	2...20
FACE AREA (sq. ft)	9.1	9.1	9.1	10.2	13.0	15.5
OUTDOOR FAN						
NOMINAL AIRFLOW (CFM)	2400	2400	2700	2700	2700	3000
DIAMETER (in.)	20	20	20	20	20	20
DIAMETER (mm)	508	508	508	508	508	508
MOTOR HP (RPM)	1/8 (825)	1/8 (825)	1/4 (1100)	1/4 (1100)	1/4 (1100)	1/3 (1110)
INDOOR COIL						
ROWS...FINS/in.	2...12	3...12	3...12	3...12	3...15	3...15
FACE AREA (sq. ft)	4.3	4.3	4.3	4.9	4.9	6.1
INDOOR BLOWER						
NOMINAL COOLING AIRFLOW (CFM)	800	1000	1200	1400	1600	1850
NOMINAL SIZE W x D (in.)	8 x 11	8 x 11	9 x 12	9 x 12	11 x 12	11 x 12
(mm)	254 x 203	254 x 203	279 x 229	279 x 229	279 x 229	267 x 305
MOTOR (HP)	1/3	1/3	1/2	1/2	3/4	1
HIGH-PRESSURE SWITCH (psig)	650 +/- 15 420 +/- 25					
CUTOUT						
RESET (AUTO)						
RETURN-AIR FILTERS*						
THROWAWAY (in.)	20x20x1	20x24x1	24x30x1	24x36x1		
(mm)	508x508x25	508x610x25	610x762x25	610x914x25		

*. Required filter sizes shown are based on the AHRI (Air Conditioning, Heating and Refrigeration Institute) rated airflow at a velocity of 300 ft/min for throwaway type or 450 ft/min for high capacity type. Recommended filters are 1-in. (25.4 mm) thick

Options and Accessories

ITEM	DESCRIPTION	FIELD INSTALLED ACCESSORY
Compressor Start Kit	Compressor Start Kit assists compressor start-up by providing additional starting torque on single phase units only.	X
Corporate Thermostats	Thermostats provide control for the system heating and cooling functions.	X
Crankcase Heater	Crankcase Heater provides anti-floodback protection for low-load cooling applications.	X*
Electric Heaters	Electric Heat Supplement	X
Low Ambient Kit	Low Ambient Kit (Motormaster II Control) allows the use of mechanical cooling down to outdoor temperatures as low as 0°F (-18°C) when properly installed.	X
Time Guard II	Automatically prevents the compressor from restarting for at least 4 minutes and 45 seconds after shutdown of the compressor. Not required when a corporate programmable thermostat is applied.	X

*. Refer to Price Page for application detail.

Accessory Electric Heaters

CATALOG ORDERING NO.	NOMINAL CAPACITY (kW)	USED WITH SIZES							
		CIRCUIT BREAKER (Yes/No)	STAGES	024	030	036	042	048	060
ELECTRIC HEATERS (208/230-SINGLE PHASE-60Hz)									
CPHEATER125A0*	3.8 / 5.0	No	1	✓	✓	✓	✓	✓	✓
CPHEATER126A0*	3.8 / 5.0	Yes	1	✓	✓	✓	✓	✓	✓
CPHEATER127A0*	5.6 / 7.5	No	2	✓	✓	✓	✓	✓	✓
CPHEATER128A0*	5.6 / 7.5	Yes	2	✓	✓	✓	✓	✓	✓
CPHEATER129A0*	7.5 / 10.0	No	2	✓	✓	✓	✓	✓	
CPHEATER130A0*	7.5 / 10.0	Yes	2	✓	✓	✓	✓	✓	✓
CPHEATER131A0*	11.3 / 15.0	Yes	2			✓	✓	✓	✓
CPHEATER132A0*	15.0 / 20.0	Yes	2					✓	✓

✓=Approved combination

Multiplication Factors

HEATER kW RATING	VOLTAGE DISTRIBUTION	MULTIPLICATION FACTOR
240	200	.69
	208	.75
	230	.92
	240	1.00

Example: 15.0 kW (at 240v) heater on 208v
 = 15.0 (.75 mult factor)
 = 11.25 capacity at 208v

Dimensional Drawing

024-036

UNIT	ELECTRICAL CHARACTERISTICS	UNIT WT.		UNIT HEIGHT				CENTER OF GRAVITY IN (MM)			
		LEBS.	KG.	A.	X.	Y.	Z.	X.	Y.	Z.	
50ZPD024---30	208/230V-1-60	217	98	30-1/8 [765]	14 [356]	19 [483]	14 [356]	19 [483]	14 [356]	14 [356]	
50ZPD030---30	208/230V-1-60	234	106	30-1/8 [765]	14 [356]	19 [483]	14 [356]	19 [483]	14 [356]	14 [356]	
50ZPD036---30	208/230V-1-60	255	116	30-1/8 [765]	14 [356]	19 [483]	14 [356]	19 [483]	14 [356]	14 [356]	

REQUIRED CLEARANCES TO COMBUSTIBLE MATL.

TOP OF UNIT..... INCHES (MM)
 BOTTOM OF UNIT..... 0
 SIDE OF UNIT WITH DUCT OPENINGS..... 0
 SIDE OF UNIT OPPOSITE DUCT OPENINGS..... 0

NEC REQUIRED CLEARANCES.

BETWEEN UNITS, POWER ENTRY SIDE..... INCHES (MM)
 UNIT AND BLOCK OR CONCRETE WALLS AND OTHER GROUNDED SURFACES, POWER ENTRY SIDE..... 42.0 [1067]

REQUIRED CLEARANCE FOR SERVICING

TOP OF UNIT..... INCHES (MM)
 SIDE OF UNIT OPPOSITE DUCT OPENINGS..... 36.0 [914]
 SIDE OF UNIT WITH POWER ENTRY..... 30.0 [762]
 (EXCEPT FOR NEC REQUIREMENTS)

NOTE: CLEARANCES MUST BE MAINTAINED TO PREVENT RECIRCULATION OF AIR FROM OUTDOOR FAN DISCHARGE. A REMOVABLE FENCE OR BARRICADE REQUIRES NO CLEARANCE.

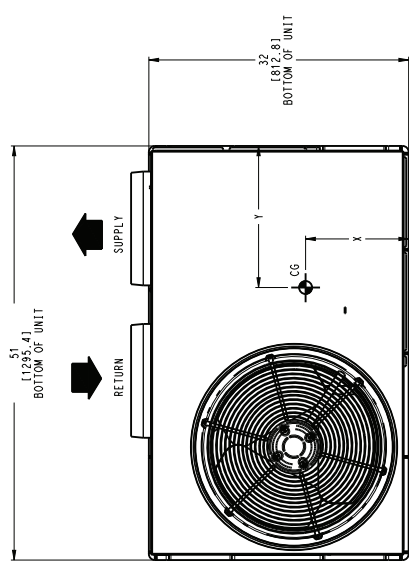

TOP VIEW

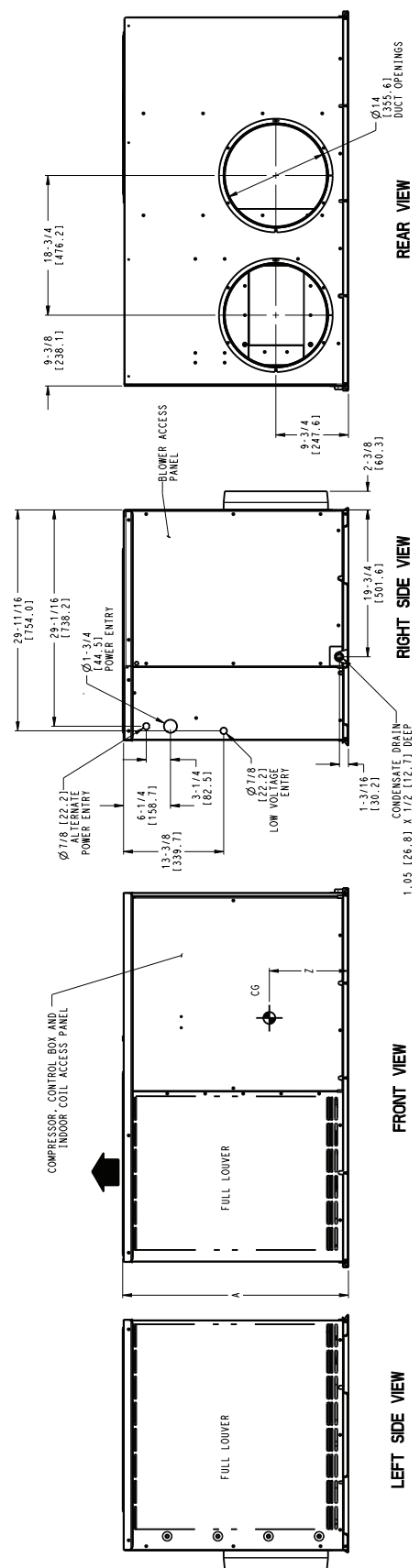

344647-4

Dimensional Drawings

042-060

UNIT	ELECTRICAL CHARACTERISTICS	UNIT WT.			UNIT HEIGHT			CENTER OF GRAVITY IN [MM]		
		LBS.	KG.	A	X	Y	Z			
50ZPC042---30	208/230-1-60	275	125	34-1/8 [867]	14 [356]	19 [483]	16 [406]			
50ZPC048---30	208/230-1-60	318	144	42-1/8 [1070]	14 [356]	19 [483]	19-3/4 [503]			
50ZPC060---30	208/230-1-60	344	156	42-1/8 [1070]	14 [356]	19 [483]	19-3/4 [503]			

REQUIRED CLEARANCES TO COMBUSTIBLE MATL

TOP OF UNIT..... INCHES [MM] 0
 BOTTOM OF UNIT..... 0
 SIDE OF UNIT WITH DUCT OPENINGS..... 0
 SIDE OF UNIT OPPOSITE DUCT OPENINGS..... 0

NEC. REQUIRED CLEARANCES

BETWEEN UNITS, POWER ENTRY SIDE..... INCHES [MM] 42.0 [1067]
 UNIT AND UNGROUNDED SURFACES, POWER ENTRY SIDE..... 42.0 [1067]
 UNIT AND BLOCK OR CONCRETE WALLS AND OTHER GROUNDED SURFACES, POWER ENTRY SIDE..... 36.0 [914]

REQUIRED CLEARANCE FOR SERVICING

TOP OF UNIT..... INCHES [MM] 36.0 [914]
 SIDE OF UNIT OPPOSITE DUCT OPENINGS..... 30.0 [762]
 SIDE OF UNIT WITH POWER ENTRY (EXCEPT FOR NEC REQUIREMENTS)..... 30.0 [762]

NOTE: CLEARANCES MUST BE MAINTAINED TO PREVENT RECIRCULATION OF AIR FROM OUTDOOR FAN DISCHARGE. A REMOVABLE FENCE OR BARRICADE REQUIRES NO CLEARANCE.

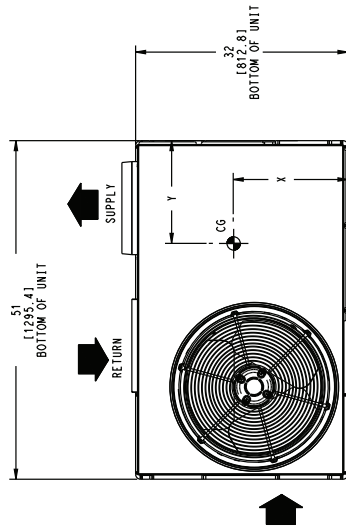

TOP VIEW

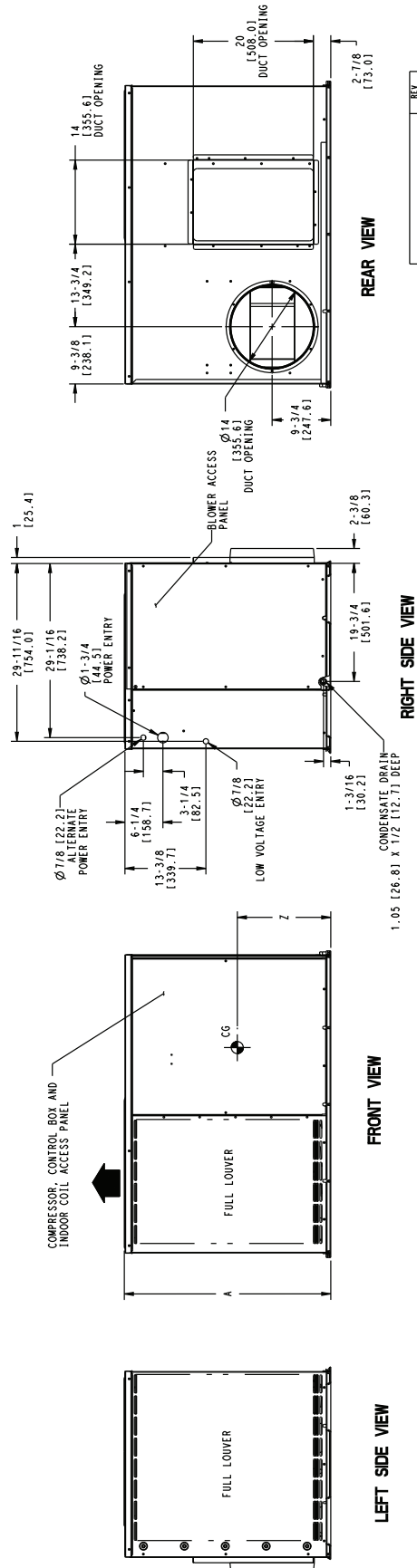

DIMENSIONS IN [] ARE IN MM

50ZP501042 REV -

Selection Procedure

DETERMINE COOLING AND HEATING REQUIREMENTS AT DESIGN CONDITIONS.

Given:

Required Cooling Capacity (TC)	34,000 Btuh
Sensible Heat Capacity (SHC).....	25,000 Btuh
Required Heating Capacity	15,000 Btuh
Outdoor Entering-Air Temperature.....	95°F (35°C)
Indoor Entering-Air Temperature	80°F edb (26.7°C); 67°F (19.4°C) ewb
Indoor-Air Quantity	1200 CFM
External Static Pressure	0.20 IN. W.C.
Electrical Characteristics (V-Ph-Hz).....	230-1-60
edb - Entering Dry Bulb	
CFM - Cubic Feet per Minute	

SELECT UNIT BASED ON REQUIRED COOLING CAPACITY (3-TON EXAMPLE)

Enter Cooling Capacities table at condenser entering temperature of 95°F (35°C), indoor air entering at 1200 CFM and 67°F (19.4°C) ewb. The 036 unit provides a total cooling capacity of 34,500 Btuh and a sensible heat capacity of 26,040 Btuh.

For indoor-air temperature other than 80°F (26.7°C) edb, calculate sensible heat capacity correction, as required, using the formula found following the Cooling Capacities tables.

NOTE: Unit ratings are net capacities.

SELECT ELECTRIC HEAT

The required heating capacity is 15,000 Btuh (given).

Determine the electric heat capacity in kW.

$$\frac{15,000 \text{ Btuh}}{3414 \text{ Btuh/kW}} = 3.8 \text{ kW of heat required}$$

Enter the Accessory Electric Heater table on page 4 for 208/230, single-phase, 036 unit. The 5-kW heater at 240v most closely satisfies the heating required. To calculate kW at 230 V, multiply the heater kW by multiplication factor 0.92 found in the Multiplication Factors table on page 4.

$$5 \text{ kW} \times 0.92 = 4.6 \text{ kW}$$

$$4.6 \text{ kW} \times 3414 \text{ Btuh/kW} = 15,704 \text{ Btuh}$$

DETERMINE FAN SPEED AND POWER REQUIREMENTS AT DESIGN CONDITIONS.

Before entering the air delivery tables, calculate the total static pressure required. From the given, Filter Pressure Drop table, and the Accessory Electric Heat Pressure Drop table find:

External static pressure	0.20 IN. W.C.
Filter	0.10 IN. W.C.
Electric Heat	<u>0.04 IN. W.C.</u>
Total static pressure	0.34 IN. W.C.

Enter the table for Dry Coil Air Delivery — Horizontal Discharge. At 0.4 IN. W.C. external static pressure and medium speed, the motor delivers 1236 CFM.

Performance Data

Cooling Capacities 024

EVAPORATOR AIR		CONDENSER ENTERING AIR TEMPERATURES °F (°C)														
		75 (23.9)			85 (29.4)			95 (35)			105 (40.6)			115 (46.1)		
		CFM	EWB °F (°C)	Capacity MBtuh		Total Sys KW*	Capacity MBtuh		Total Sys KW*	Capacity MBtuh		Total Sys KW*	Capacity MBtuh		Total Sys KW*	Capacity MBtuh
Total	Sens†			Total	Sens†		Total	Sens†		Total	Sens†		Total	Sens†		
700	57 (13.9)	21.11	21.11	1.61	20.33	20.33	1.80	19.44	19.44	2.00	18.39	18.39	2.22	16.99	16.99	2.45
	62 (16.7)	21.97	20.56	1.61	21.01	20.12	1.80	19.92	19.58	2.01	18.62	18.89	2.23	16.85	16.85	2.45
	63‡ (17.2)	22.40	16.82	1.61	21.41	16.39	1.80	20.31	15.89	2.01	18.95	15.25	2.23	17.10	14.40	2.45
	67 (19.4)	24.12	17.41	1.62	23.11	16.98	1.81	21.98	16.51	2.03	20.69	15.99	2.27	19.08	15.31	2.53
	71 (21.7)	25.87	14.83	1.64	24.84	14.43	1.83	23.69	13.97	2.04	22.40	13.46	2.29	20.92	12.89	2.56
800	57 (13.9)	22.00	22.00	1.62	21.20	21.20	1.81	20.32	20.32	2.03	19.24	19.24	2.26	17.84	17.84	2.49
	62 (16.7)	22.51	21.92	1.63	21.54	21.49	1.82	20.47	20.95	2.03	19.27	19.27	2.26	17.87	17.87	2.49
	63‡ (17.2)	22.88	17.76	1.63	21.86	17.34	1.82	20.73	16.85	2.03	19.36	16.24	2.26	17.53	15.41	2.48
	67 (19.4)	24.61	18.36	1.64	23.57	17.97	1.83	22.40	17.50	2.04	21.09	16.99	2.29	19.53	16.40	2.56
	71 (21.7)	26.33	15.46	1.65	25.29	15.08	1.84	24.10	14.63	2.06	22.78	14.13	2.31	21.28	13.57	2.58
900	57 (13.9)	22.74	22.74	1.64	21.92	21.92	1.83	21.01	21.01	2.05	19.95	19.95	2.29	18.58	18.58	2.54
	62 (16.7)	22.99	23.16	1.64	22.01	22.69	1.83	21.02	21.02	2.05	19.97	19.97	2.29	18.61	18.61	2.54
	63‡ (17.2)	23.26	18.63	1.64	22.21	18.21	1.83	21.06	17.74	2.05	19.70	17.18	2.29	17.88	16.36	2.51
	67 (19.4)	24.98	19.24	1.65	23.91	18.86	1.84	22.71	18.43	2.06	21.39	17.90	2.30	19.82	17.35	2.58
	71 (21.7)	26.69	16.04	1.67	25.63	15.67	1.86	24.42	15.24	2.08	23.06	14.74	2.32	21.55	14.19	2.60

See Legend and Notes on page 11.

030

EVAPORATOR AIR		CONDENSER ENTERING AIR TEMPERATURES °F (°C)														
		75 (23.9)			85 (29.4)			95 (35)			105 (40.6)			115 (46.1)		
		CFM	EWB °F (°C)	Capacity MBtuh		Total Sys KW*	Capacity MBtuh		Total Sys KW*	Capacity MBtuh		Total Sys KW*	Capacity MBtuh		Total Sys KW*	Capacity MBtuh
Total	Sens†			Total	Sens†		Total	Sens†		Total	Sens†		Total	Sens†		
875	57 (13.9)	27.60	27.60	1.98	26.50	26.50	2.19	25.24	25.24	2.42	23.71	23.71	2.67	21.76	21.76	2.93
	62 (16.7)	28.34	26.09	1.98	26.97	25.48	2.19	25.44	24.73	2.43	23.76	23.76	2.67	21.80	21.80	2.93
	63‡ (17.2)	28.82	21.14	1.99	27.42	20.55	2.20	25.85	19.89	2.44	23.90	19.03	2.67	21.30	17.92	2.91
	67 (19.4)	31.10	21.94	2.00	29.67	21.41	2.22	28.08	20.78	2.46	26.22	20.05	2.73	23.80	19.09	3.00
	71 (21.7)	33.50	18.60	2.03	32.03	18.06	2.24	30.40	17.48	2.48	28.60	16.81	2.77	26.45	16.02	3.08
1000	57 (13.9)	28.80	28.80	2.01	27.65	27.65	2.22	26.38	26.38	2.47	24.84	24.84	2.73	22.85	22.85	2.99
	62 (16.7)	29.07	27.98	2.01	27.73	27.50	2.22	26.42	26.42	2.47	24.88	24.88	2.73	22.89	22.89	2.99
	63‡ (17.2)	29.43	22.47	2.01	27.98	21.90	2.22	26.39	21.24	2.47	24.44	20.41	2.72	21.82	19.29	2.95
	67 (19.4)	31.71	23.32	2.03	30.24	22.82	2.24	28.60	22.20	2.49	26.75	21.50	2.76	24.35	20.58	3.05
	71 (21.7)	34.11	19.53	2.05	32.60	19.03	2.27	30.92	18.43	2.51	29.06	17.77	2.80	26.90	17.01	3.11
1125	57 (13.9)	29.76	29.76	2.04	28.59	28.59	2.25	27.28	27.28	2.50	25.75	25.75	2.77	23.78	23.78	3.05
	62 (16.7)	29.80	29.80	2.04	28.63	28.63	2.25	27.32	27.32	2.50	25.78	25.78	2.78	23.82	23.81	3.05
	63‡ (17.2)	29.89	23.71	2.04	28.42	23.16	2.25	26.81	22.52	2.49	24.85	21.71	2.75	22.25	20.59	2.99
	67 (19.4)	32.18	24.61	2.06	30.66	24.12	2.27	29.01	23.55	2.51	27.14	22.85	2.79	24.81	21.99	3.09
	71 (21.7)	34.59	20.40	2.08	33.04	19.89	2.29	31.31	19.33	2.54	29.40	18.68	2.82	27.22	17.94	3.14

See Legend and Notes on page 11.

Manufacturer reserves the right to change, at any time, specifications and designs without notice and without obligations.

Cooling Capacities (cont)

036

EVAPORATOR AIR		CONDENSER ENTERING AIR TEMPERATURES °F (°C)														
		75 (23.9)			85 (29.4)			95 (35)			105 (40.6)			115 (46.1)		
		CFM	EWB °F (°C)	Capacity MBtuh		Total Sys KW*	Capacity MBtuh		Total Sys KW*	Capacity MBtuh		Total Sys KW*	Capacity MBtuh		Total Sys KW*	Capacity MBtuh
Total	Sens†			Total	Sens†	Total	Sens†	Total	Sens†	Total	Sens†	Total	Sens†	Total	Sens†	
1050	57 (13.9)	33.44	33.44	2.35	31.96	31.96	2.59	29.97	29.97	2.84	27.67	27.67	3.12	25.22	25.22	3.45
	62 (16.7)	34.22	31.29	2.36	32.42	30.45	2.60	30.12	29.15	2.84	27.72	27.72	3.12	25.24	25.24	3.45
	63‡ (17.2)	34.84	25.34	2.36	32.94	24.51	2.60	30.42	23.42	2.85	27.34	22.11	3.11	24.16	20.79	3.42
	67 (19.4)	37.73	26.43	2.41	35.79	25.64	2.66	33.57	24.74	2.93	30.40	23.49	3.18	27.11	22.21	3.49
	71 (21.7)	40.85	22.45	2.44	38.88	21.72	2.71	36.70	20.91	3.00	33.78	19.82	3.27	30.28	18.55	3.57
1200	57 (13.9)	34.88	34.88	2.40	33.34	33.34	2.65	31.45	31.45	2.91	28.98	28.98	3.18	26.41	26.41	3.51
	62 (16.7)	35.12	33.55	2.40	33.20	33.20	2.64	31.51	31.51	2.91	29.02	29.02	3.18	26.46	26.46	3.51
	63‡ (17.2)	35.55	26.89	2.40	33.61	26.06	2.65	31.13	25.01	2.90	28.00	23.71	3.16	24.74	22.34	3.47
	67 (19.4)	38.47	28.10	2.45	36.47	27.30	2.70	34.20	26.40	2.97	31.08	25.20	3.23	27.68	23.88	3.54
	71 (21.7)	41.59	23.57	2.48	39.58	22.87	2.75	37.38	22.07	3.04	34.48	21.01	3.33	30.86	19.72	3.62
1350	57 (13.9)	36.08	36.08	2.45	34.48	34.48	2.70	32.64	32.64	2.97	30.06	30.06	3.24	27.39	27.39	3.56
	62 (16.7)	36.12	36.12	2.45	34.54	34.54	2.70	32.69	32.69	2.97	30.11	30.11	3.24	27.44	27.44	3.56
	63‡ (17.2)	36.10	28.35	2.44	34.12	27.53	2.69	31.76	26.55	2.95	28.50	25.18	3.20	25.21	23.76	3.51
	67 (19.4)	39.04	29.64	2.48	36.98	28.88	2.74	34.70	27.99	3.02	31.57	26.78	3.27	28.16	25.44	3.58
	71 (21.7)	42.15	24.61	2.51	40.11	23.92	2.78	37.87	23.13	3.08	35.02	22.12	3.38	31.28	20.82	3.67

See Legend and Notes on page 11.

042

EVAPORATOR AIR		CONDENSER ENTERING AIR TEMPERATURES °F (°C)														
		75 (24)			85 (29)			95 (35)			105 (41)			115 (46)		
		CFM	EWB °F (°C)	Capacity MBtuh		Total Sys KW*	Capacity MBtuh		Total Sys KW*	Capacity MBtuh		Total Sys KW*	Capacity MBtuh		Total Sys KW*	Capacity MBtuh
Total	Sens†			Total	Sens†	Total	Sens†	Total	Sens†	Total	Sens†	Total	Sens†	Total	Sens†	
1225	57 (14)	41.68	41.68	2.75	38.94	38.94	3.11	35.98	35.98	3.49	32.25	32.25	3.87	28.66	28.66	4.32
	62 (17)	42.95	38.93	2.75	39.78	36.79	3.12	36.43	34.57	3.50	32.28	32.28	3.87	28.71	28.71	4.32
	63‡ (17)	43.70	31.61	2.75	40.44	29.72	3.12	36.99	27.79	3.51	32.43	25.38	3.87	27.98	23.06	4.30
	67 (19)	47.16	32.78	2.77	43.74	30.91	3.13	40.27	29.04	3.52	36.10	26.97	3.96	31.37	24.61	4.39
	71 (22)	51.59	26.51	2.78	47.98	24.89	3.15	44.33	23.26	3.55	40.57	21.60	3.99	36.10	19.78	4.49
1400	57 (14)	43.43	43.43	2.79	40.56	40.56	3.15	37.56	37.56	3.55	33.84	33.84	3.94	30.06	30.06	4.39
	62 (17)	44.02	41.66	2.79	40.84	39.39	3.16	37.60	37.60	3.55	33.90	33.90	3.94	30.11	30.11	4.40
	63‡ (17)	44.60	33.50	2.79	41.26	31.57	3.16	37.77	29.61	3.55	33.24	27.21	3.92	28.66	24.78	4.36
	67 (19)	48.06	34.74	2.81	44.57	32.83	3.17	41.00	30.90	3.56	37.08	28.93	4.01	32.09	26.48	4.45
	71 (22)	52.46	27.65	2.82	48.78	26.00	3.19	45.03	24.35	3.59	41.21	22.67	4.03	36.86	20.91	4.53
1575	57 (14)	44.86	44.86	2.83	41.89	41.89	3.19	38.82	38.82	3.59	35.20	35.20	4.02	31.25	31.25	4.47
	62 (17)	45.00	44.04	2.83	41.94	41.94	3.20	38.88	38.88	3.59	35.25	35.25	4.02	31.28	31.28	4.47
	63‡ (17)	45.28	35.25	2.83	41.88	33.29	3.20	38.36	31.31	3.59	33.90	28.93	3.98	29.21	26.39	4.41
	67 (19)	48.74	36.57	2.84	45.17	34.62	3.21	41.56	32.62	3.60	37.71	30.65	4.05	32.66	28.22	4.50
	71 (22)	53.13	28.71	2.86	49.38	27.04	3.23	45.55	25.35	3.63	41.66	23.65	4.07	37.49	21.93	4.58

See Legend and Notes on page 11.

Manufacturer reserves the right to change, at any time, specifications and designs without notice and without obligations.

Cooling Capacities (cont)

048

EVAPORATOR AIR		CONDENSER ENTERING AIR TEMPERATURES °F (°C)														
CFM	EWB °F (°C)	75 (24)			85 (29)			95 (35)			105 (41)			115 (46)		
		Capacity MBtuh		Total Sys KW*	Capacity MBtuh		Total Sys KW*	Capacity MBtuh		Total Sys KW*	Capacity MBtuh		Total Sys KW*	Capacity MBtuh		Total Sys KW*
		Total	Sens†		Total	Sens†		Total	Sens†		Total	Sens†		Total	Sens†	
1400	57 (14)	46.69	46.69	3.18	43.96	43.96	3.55	41.20	41.20	3.97	38.15	38.15	4.45	34.26	34.26	4.96
	62 (17)	48.24	40.86	3.19	45.07	40.07	3.56	41.86	39.18	3.99	38.39	38.02	4.46	34.32	34.32	4.97
	63‡ (17)	49.13	33.18	3.19	45.86	32.38	3.57	42.55	31.50	4.00	38.89	30.43	4.47	34.04	28.78	4.95
	67 (19)	53.03	34.45	3.21	49.63	33.69	3.59	46.16	32.87	4.03	42.51	31.94	4.54	38.08	30.67	5.10
	71 (22)	58.07	27.87	3.25	54.53	27.15	3.63	50.89	26.37	4.07	47.09	25.48	4.58	43.08	24.48	5.17
1600	57 (14)	48.69	48.69	3.24	45.86	45.86	3.62	42.97	42.97	4.06	39.87	39.87	4.56	35.98	35.98	5.08
	62 (17)	49.45	43.78	3.24	46.24	42.96	3.62	43.08	42.83	4.06	39.93	39.93	4.56	36.04	36.04	5.08
	63‡ (17)	50.14	35.19	3.25	46.79	34.40	3.62	43.38	33.54	4.06	39.71	32.52	4.55	34.85	30.91	5.04
	67 (19)	54.04	36.51	3.27	50.57	35.78	3.65	47.00	35.00	4.09	43.31	34.10	4.60	39.07	33.00	5.18
1800	71 (22)	59.08	29.08	3.31	55.45	28.38	3.69	51.71	27.61	4.13	47.83	26.75	4.64	43.74	25.74	5.24
	57 (14)	50.32	50.32	3.30	47.39	47.39	3.68	44.38	44.38	4.12	41.24	41.24	4.63	37.45	37.45	5.19
	62 (17)	50.52	46.35	3.30	47.46	47.46	3.68	44.44	44.44	4.12	41.29	41.29	4.63	37.50	37.50	5.19
	63‡ (17)	50.90	37.05	3.30	47.50	36.30	3.68	44.02	35.46	4.12	40.35	34.49	4.62	35.52	32.90	5.12
	67 (19)	54.81	38.44	3.33	51.26	37.75	3.70	47.64	36.98	4.14	43.89	36.11	4.65	39.74	35.07	5.24
71 (22)	59.83	30.17	3.37	56.13	29.51	3.75	52.32	28.76	4.19	48.35	27.90	4.70	44.21	26.91	5.30	

See Legend and Notes on page 11

060

EVAPORATOR AIR		CONDENSER ENTERING AIR TEMPERATURES °F (°C)														
CFM	EWB °F (°C)	75 (24)			85 (29)			95 (35)			105 (41)			115 (46)		
		Capacity MBtuh		Total Sys KW*	Capacity MBtuh		Total Sys KW*	Capacity MBtuh		Total Sys KW*	Capacity MBtuh		Total Sys KW*	Capacity MBtuh		Total Sys KW*
		Total	Sens†		Total	Sens†		Total	Sens†		Total	Sens†		Total	Sens†	
1500	57 (14)	52.95	52.95	3.74	50.23	50.23	4.14	47.43	47.43	4.61	44.47	44.47	5.15	41.30	41.30	5.78
	62 (17)	55.05	45.97	3.75	51.84	44.39	4.16	48.53	42.78	4.62	45.08	41.06	5.16	41.48	39.18	5.78
	63‡ (17)	56.01	37.50	3.76	52.73	36.05	4.17	49.33	34.54	4.63	45.76	32.97	5.17	42.01	31.33	5.79
	67 (19)	59.99	38.77	3.80	56.43	37.29	4.20	52.75	35.77	4.67	48.90	34.18	5.21	44.88	32.53	5.83
	71 (22)	65.50	31.45	3.84	61.58	30.06	4.25	57.53	28.62	4.72	53.33	27.13	5.26	48.93	25.58	5.89
1700	57 (14)	54.98	54.98	3.81	52.11	52.11	4.21	49.12	49.12	4.68	45.98	45.98	5.23	42.63	42.63	5.85
	62 (17)	56.20	49.14	3.82	52.89	47.48	4.22	49.49	45.72	4.69	46.04	46.04	5.23	42.69	42.69	5.86
	63‡ (17)	57.05	39.66	3.83	53.64	38.16	4.23	50.11	36.61	4.70	46.43	34.99	5.23	42.56	33.29	5.85
	67 (19)	61.05	41.09	3.86	57.35	39.56	4.26	53.53	37.99	4.73	49.57	36.36	5.27	45.42	34.64	5.89
1850	71 (22)	66.61	32.86	3.91	62.53	31.43	4.31	58.37	29.96	4.78	54.02	28.44	5.33	49.49	26.85	5.95
	57 (14)	56.30	56.30	3.86	53.30	53.30	4.27	50.20	50.20	4.74	46.93	46.93	5.28	43.46	43.46	5.91
	62 (17)	56.95	51.37	3.87	53.60	49.58	4.27	50.27	50.27	4.74	46.99	46.99	5.28	43.52	43.52	5.91
	63‡ (17)	57.68	41.23	3.87	54.17	39.68	4.27	50.58	38.10	4.74	46.82	36.45	5.28	42.89	34.72	5.90
	67 (19)	61.67	42.77	3.90	57.88	41.20	4.31	54.00	39.60	4.78	49.95	37.93	5.32	45.73	36.18	5.94
71 (22)	67.25	33.87	3.95	63.10	32.42	4.36	58.84	30.93	4.83	54.41	29.38	5.37	49.81	27.77	6.00	

See Legend and Notes on page 11.

Manufacturer reserves the right to change, at any time, specifications and designs without notice and without obligations.

*System kW is total of indoor and outdoor unit kilowatts.

†Sensible capacities shown are based on 80°F (27°C) entering air at the indoor coil. For sensible capacities at other than 80°F (27°C), deduct 835 Btuh (245 kW) per 1000 CFM (480 L/S) of indoor coil air for each degree below 80°F (27°C), or add 835 Btuh (245 kW) per 1000 CFM (480L/S) of indoor coil air per degree above 80°F (27°C).

‡At TVA rating indoor condition (75°F edb/63°F ewb). All other indoor air temperatures are at 80°F (27°C) edb.

LEGEND

BF — Bypass Factor

CFM — Cubic Feet per Minute

edb — Entering Dry Bulb

ewb — Entering Wet-Bulb

^hewb — Enthalpy, entering wet bulb

^hlwb — Enthalpy, leaving wet bulb

kW — Total Unit Power Input

SHC — Sensible Heat Capacity (1000 Btuh)

^t = Temperature (°F)

^tedb — Entering Temperature, Dry Bulb (°F)

^tldb — Leaving Temperature, Dry Bulb (°F)

^tlwb — Leaving Temperature, Wet Bulb (°F)

TC — Total Capacity (1000 Btuh) (net)

NOTES:

1. Direct interpolation is permissible. Do not extrapolate.

2. The following formulas may be used:

$${}^t\text{ldb} = {}^t\text{edb} - \frac{\text{Sensible capacity (Btuh)}}{1.10 \times \text{CFM}}$$

$${}^h\text{lwb} = \text{Wet-bulb temperature corresponding to enthalpy air leaving evaporator coil } ({}^h\text{lwb})$$

$${}^h\text{lwb} = {}^h\text{ewb} - \frac{\text{total capacity (Btuh)}}{(4.5 \times \text{CFM})}$$

Where: ^hewb = Enthalpy of air entering evaporator coil

The SHC is based on 80°F (26.7°C) edb temperature of air entering indoor coil.

Below 80°F (25.7°C) edb, subtract (corr factor x CFM) from SHC.

Above 80°F (25.7°C) edb, add (corr factor x CFM) from SHC.

Correction Factor = 1.10 x (1 - BF) x (edb - 80)

Filter Pressure Drop (IN. W.C.)

FILTER SIZE in. (mm)	CFM																	
	500	600	700	800	900	1000	1100	1200	1300	1400	1500	1600	1700	1800	1900	2000	2100	2200
20X20X1 (508X508X25)	0.05	0.07	0.08	0.10	0.12	0.13	0.14	0.15	—	—	—	—	—	—	—	—	—	—
20X24X1 (508X610x25)	—	—	—	0.08	0.09	0.10	0.11	0.13	0.14	0.15	0.16	—	—	—	—	—	—	—
24X30X1 (610X762x25)	—	—	—	0.04	0.05	0.06	0.07	0.07	0.08	0.09	0.10	—	—	—	—	—	—	—
24X36X1 (610X914X25)	—	—	—	—	—	—	—	0.06	0.07	0.07	0.08	0.09	0.09	0.10	0.11	0.12	0.13	0.14

Accessory Electric Heat Pressure Drop (IN. W.C.)

HEATER kW	CFM							
	800	1000	1200	1400	1600	1800	2000	2200
5-20	0.033	0.037	0.042	0.047	0.052	0.060	0.067	0.075

Wet Coil Delivery* — (Deduct 10% for 208-Volt Operation)

UNIT SIZE	SPEED TAP	AIR DELIVERY†	EXTERNAL STATIC PRESSURE (in. W.C.)									
			0.1	0.2	0.3	0.4	0.5	0.6	0.7	0.8	0.9	1.0
024	1	SCFM	965	818	777	731	670	617	563	489	451	391
	2	SCFM	1003	921	890	850	809	756	700	659	597	539
	3	SCFM	1103	1068	1034	996	962	930	892	821	791	742
030	1	SCFM	1052	1018	984	943	914	879	833	795	732	678
	2	SCFM	1141	1107	1069	1036	1006	974	932	899	856	784
	3	SCFM	1246	1213	1181	1144	1108	1078	1043	1015	973	931
036	1	SCFM	1281	1225	1178	1142	1098	1053	1008	935	878	840
	2	SCFM	1359	1321	1278	1236	1201	1160	1109	1068	992	941
	3	SCFM	1476	1441	1403	1366	1323	1289	1245	1201	1159	1117
042	1	SCFM	1453	1408	1373	1337	1295	1255	1215	1177	1134	1068
	2	SCFM	1544	1507	1475	1436	1397	1359	1326	1290	1246	1201
	3	SCFM	1614	1575	1542	1509	1467	1430	1395	1358	1323	1267
048	1	SCFM	1657	1625	1590	1554	1517	1486	1448	1417	1381	1340
	2	SCFM	1707	1673	1644	1614	1586	1549	1515	1479	1449	1407
	3	SCFM	1931	1900	1870	1840	1809	1778	1749	1714	1683	1646
060	1	SCFM	1931	1881	1833	1787	1746	1698	1670	1622	1577	1514
	2	SCFM	2038	1994	1935	1894	1851	1811	1774	1738	1691	1648
	3	SCFM	2144	2113	2052	2001	1974	1928	1898	1860	1824	1773

*. Air delivery values are based on operating voltage of 230v, wet coil, without filter or electric heater. Deduct filter and electric heater pressure drops to obtain static pressure available for ducting.

†. Standard Cubic Feet per Minute.

NOTES:

1. Do not operate the unit at a cooling airflow that is less than 350 CFM for each 12,000 Btuh of rated cooling capacity. Evaporator coil frosting may occur at airflows below this point.

Typical Connection Wiring Schematic

208/230-1-60 024-060

CONNECTION WIRING DIAGRAM

DANGER: ELECTRICAL SHOCK HAZARD DISCONNECT POWER BEFORE SERVICING

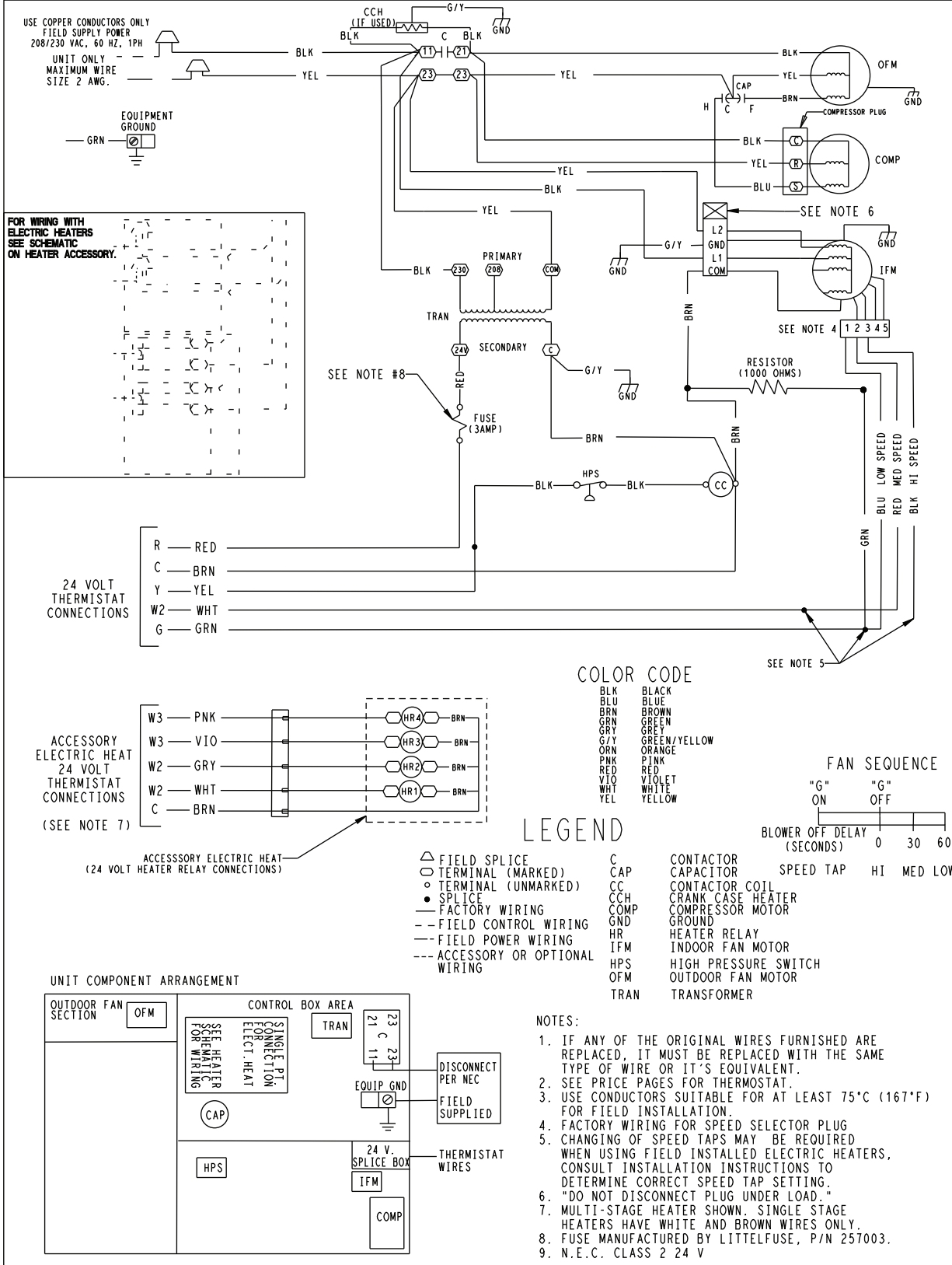

R — RED
C — BRN
Y — YEL
W2 — WHT
G — GRN

W3 — PNK
W3 — VIO
W2 — GRY
W2 — WHT
C — BRN

COLOR CODE

BLK BLACK
BLU BLUE
BRN BROWN
GRN GREEN
GRY GREY
G/Y GREEN/YELLOW
ORN ORANGE
PNK PINK
RED RED
VIO VIOLET
WHT WHITE
YEL YELLOW

FAN SEQUENCE

"G" ON "G" OFF

BLOWER OFF DELAY (SECONDS) 0 30 60

SPEED TAP HI MED LOW

LEGEND

- △ FIELD SPLICE
- TERMINAL (MARKED)
- TERMINAL (UNMARKED)
- SPLICE
- FACTORY WIRING
- - - FIELD CONTROL WIRING
- - - FIELD POWER WIRING
- - - ACCESSORY OR OPTIONAL WIRING
- C CONTACTOR
- CAP CAPACITOR
- CC CONTACTOR COIL
- CCH CRANK CASE HEATER
- COMP COMPRESSOR MOTOR
- GND GROUND
- HR HEATER RELAY
- IFM INDOOR FAN MOTOR
- HPS HIGH PRESSURE SWITCH
- OFM OUTDOOR FAN MOTOR
- TRAN TRANSFORMER

- NOTES:**
- IF ANY OF THE ORIGINAL WIRES FURNISHED ARE REPLACED, IT MUST BE REPLACED WITH THE SAME TYPE OF WIRE OR IT'S EQUIVALENT.
 - SEE PRICE PAGES FOR THERMOSTAT.
 - USE CONDUCTORS SUITABLE FOR AT LEAST 75°C (167°F) FOR FIELD INSTALLATION.
 - FACTORY WIRING FOR SPEED SELECTOR PLUG
 - CHANGING OF SPEED TAPS MAY BE REQUIRED WHEN USING FIELD INSTALLED ELECTRIC HEATERS, CONSULT INSTALLATION INSTRUCTIONS TO DETERMINE CORRECT SPEED TAP SETTING.
 - "DO NOT DISCONNECT PLUG UNDER LOAD."
 - MULTI-STAGE HEATER SHOWN. SINGLE STAGE HEATERS HAVE WHITE AND BROWN WIRES ONLY.
 - FUSE MANUFACTURED BY LITTELFUSE, P/N 257003.
 - N.E.C. CLASS 2 24 V

Typical Field Wiring

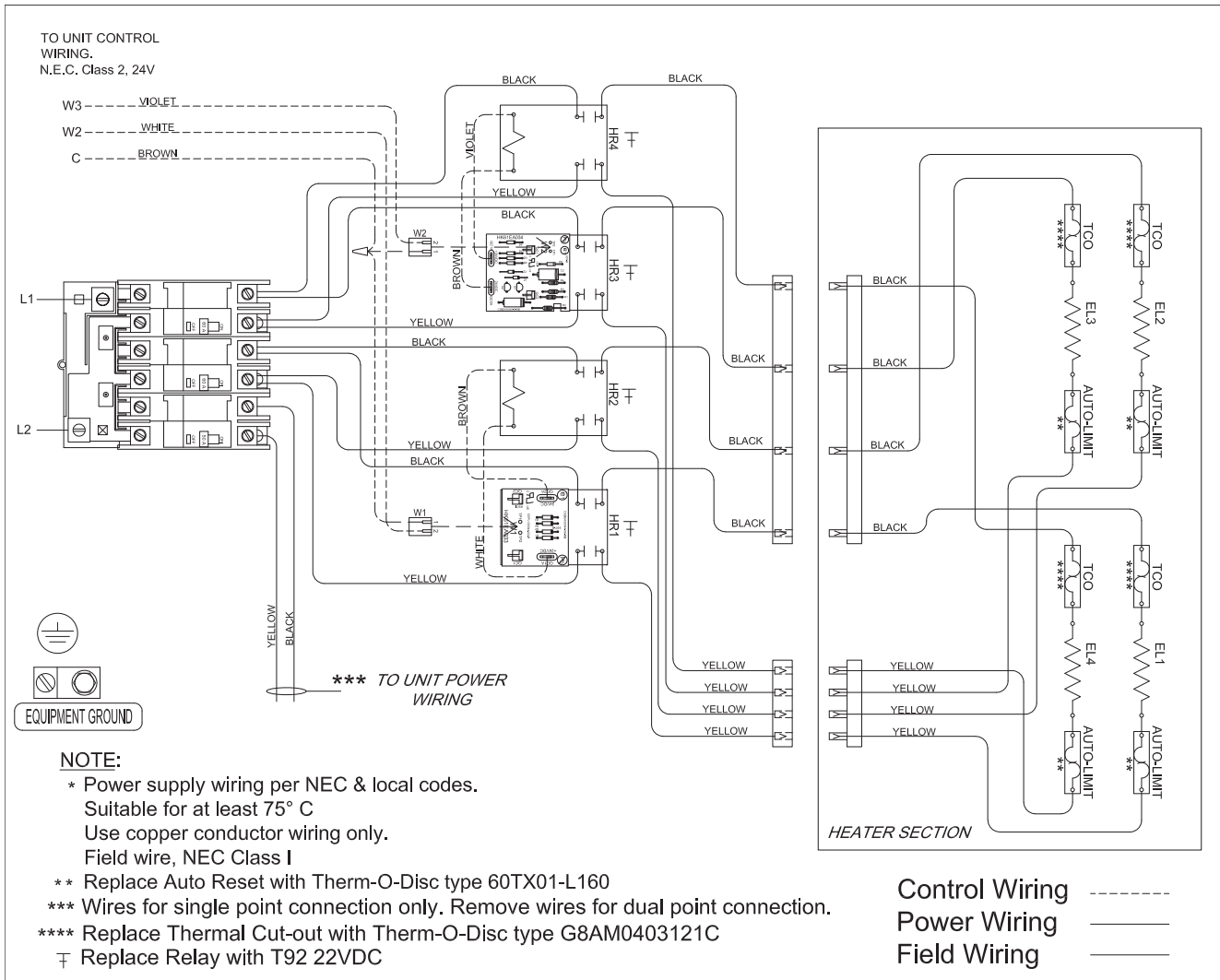

KILOWATTS	VOLTS	PHASE	HERTZ	CONTROL VOLTS	STEPS	HEATER AMPS	CIRCUIT BREAKER		
							C.B. # 1	C.B. # 2	C.B. # 3
15.0/20.0	208/240	1	60	24 AC	2	72.1/83.3	50A	60A	60A
CPHEATER132A03 (110070158)									

A190339

Single-Phase Accessory Electric Heater Wiring

Electrical Data

Model	Nominal V-PH-HZ	Voltage Range		Compressor		OFM	IFM	Nominal kW*	Heater FLA		MCA		MOCPT†
		Min	Max	RLA	LRA	FLA	FLA		208/240	208	240	208	230
024	208/230-1-60	197	253	10.3	61.6	0.9	2.8	-/-	-	-	16.6	16.6	25
								3.8/5	18.0	20.8	26.0	29.5	30/30
								5.6/7.5	27.0	31.3	37.3	42.6	40/45
								7.5/10	36.1	41.7	48.6	55.6	50/60
030	208/230-1-60	197	253	13.5	72.5	0.9	2.8	-/-	-	-	20.6	20.6	30
								3.8/5	18.0	20.8	26.0	29.5	30/30
								5.6/7.5	27.0	31.3	37.3	42.6	40/45
								7.5/10	36.1	41.7	48.6	55.6	50/60
036	208/230-1-60	197	253	14.1	77.0	1.5	4.1	-/-	-	-	23.2	23.2	35
								3.8/5	18.0	20.8	27.6	31.1	35/35
								5.6/7.5	27.0	31.3	38.9	44.3	40/45
								7.5/10	36.1	41.7	50.3	57.3	60/60
042	208/230-1-60	197	253	15.9	112.3	1.7	4.1	-/-	-	-	25.7	25.7	40
								3.8/5	18.0	20.8	27.6	31.1	40/40
								5.6/7.5	27.0	31.3	38.9	44.3	40/45
								7.5/10	36.1	41.7	50.3	57.3	60/60
048	208/230-1-60	197	253	19.6	130	1.7	6.0	-/-	-	-	32.2	32.2	50
								3.8/5	18.0	20.8	32.2	33.5	50/50
								5.6/7.5	27.0	31.3	41.3	46.6	50/50
								7.5/10	36.1	41.7	52.6	59.6	60/60
060	208/230-1-60	197	253	23.7	152.5	1.9	7.6	-/-	-	-	39.1	39.1	60
								3.8/5	18.0	20.8	39.1	39.1	60/60
								5.6/7.5	27.0	31.3	43.3	48.6	60/60
								7.5/10	36.1	41.7	54.6	61.6	60/70
								11.3/15	54.1	62.5	77.1	87.6	80/90
								15/20	72.1	83.3	99.6	113.6	100/125

*. Heater capacity (kW) based on heater voltage of 208v & 240v. If power distribution voltage to unit varies from rated heater voltage, heater kW will vary accordingly.

†. HACR Type Circuit breaker

LEGEND

FLA - Full Load Amps

LRA - Locked Rotor Amps

MCA - Minimum Circuit Amps

MOCPT - Maximum Overcurrent Protection

RLA - Rated Load Amps

NOTES:

- In compliance with NEC (National Electrical Code) requirements for multi motor and combination load equipment (refer to NEC Articles 430 and 440), the overcurrent protective device for the unit shall be Power Supply fuse or circuit breaker.
- Minimum wire size is based on 60°C copper wire. If other than 60°C wire is used, or if length exceeds wire length in table, determine size from NEC.

Operating Sequence

Cooling Operation

With a call for cooling (Y/G), the contactor is energized which brings on the compressor and outdoor fan. The indoor fan is also energized. When the cooling demand is met, Y and G are de-energized shutting off the contactor. The indoor fan stops after a 60 second delay.

Heating Operation

With a call for heating (W2), the auxiliary or electric heat energizes along with the indoor blower. In case of staged heating, W3 is energized if the demand is not met. The highest airflow selected is run while the electric heat is in operation. When heating demand is met, W3 and W2 sequentially de-energize shutting off the indoor fan and the electric heater.

Continuous Fan

With the continuous indoor fan option selected on the thermostat, G is continuously energized keeping the indoor fan running at all times.

Application Data

Condensate trap — A 2-in. (51 mm) condensate trap must be field supplied.

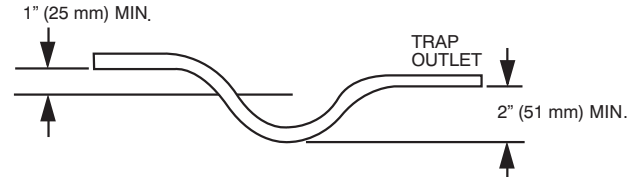

A08001

Maximum cooling airflow — To minimize the possibility of condensate blow-off from the evaporator, airflow through the units should not exceed 450 CFM/ton.

Minimum cooling airflow — The minimum cooling airflow is 350 CFM/ton.

Minimum cooling operating outdoor air temperature — All standard units have a minimum ambient operating temperature of 40°F (4.4°C). With accessory low ambient temperature kit, units can operate at temperatures down to 0°F (-17.8°C).

Maximum operating outdoor air temperature — Maximum outdoor operating air temperature for cooling is 125°F (51.7°C).

Typical Installation

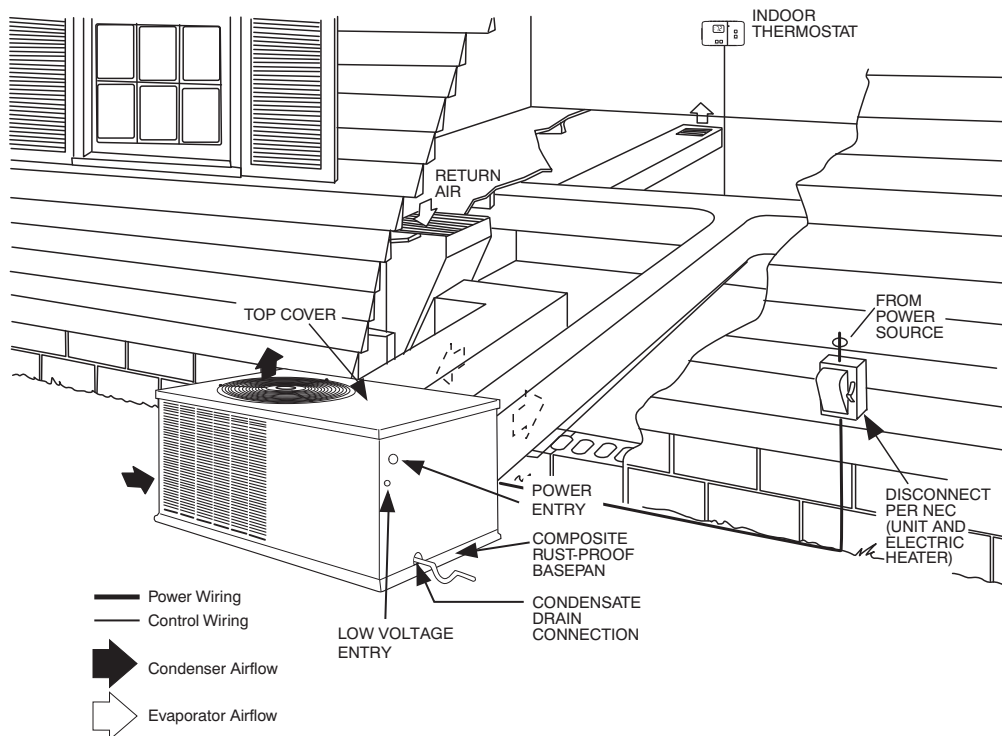

A10135

Guide Specifications

General

Furnish and install outdoor package, electrically controlled, air conditioner utilizing a reciprocating or scroll compressor for cooling duty. Unit shall discharge supply air horizontally as shown on contract drawings.

Nominal unit electrical characteristics shall be _____ v, _____ ph, 60 Hz. The unit shall be capable of satisfactory operation within voltage limits of _____ v to _____ v. Unit power wiring shall enter unit cabinet at a single location.

Separate power supply shall not be required for electric heat.

Cooling Capacity

Total cooling capacity of the unit shall be _____ Btuh or greater, and sensible capacity shall be _____ Btuh or greater at conditions of _____ CFM indoor air entering unit at _____ F dry bulb, _____ F wet bulb and outdoor entering air of _____ F dry bulb. Total design conditions shall be a minimum of _____ Btuh/Watt. The unit shall be capable of cooling operation down to 40°F (4.4°C) as shipped from the factory.

Cabinet

Unit cabinet shall be constructed of phosphated, bonderized, zinc-coated, prepainted steel. Basepan shall be made of a single-piece non-corrosive, composite material.

Evaporator-fan compartment interior cabinet surfaces shall be insulated with a minimum 1/2-in. (12.7 mm) thick, flexible fiberglass insulation, coated on the air side with aluminum foil.

Cabinet panels shall be easily removable for servicing.

Outdoor coil shall be protected by metal louvered panels.

Compressor

Compressor shall be fully hermetic type with external vibration isolation.

Condenser Section

Condenser fan shall be of the direct-driven propeller type blades, riveted to corrosion-resistant spiders, and shall be dynamically balanced and discharge air vertically upwards.

Condenser coils shall have aluminum-plate fins mechanically bonded to copper tubes with all joints brazed.

Tube sheet openings shall be belled to prevent tube wear.

Evaporator Section

Fan shall be multi-speed with direct drive motor as shown on the equipment drawings.

Fan wheel shall be made from steel, be double-inlet type with forward-curved blades with a corrosion-resistant finish and dynamically balanced.

Evaporator coils shall have aluminum-plate fins mechanically bonded to copper tubes with all joints brazed.

Tube sheet openings shall be belled to prevent tube wear.

Motors

Compressor motors shall be of the refrigerant cooled type with line break thermal and current overload protection.

All fan motors shall have permanently lubricated bearings, and inherent automatic reset thermal overload protection.

Condenser fan motor shall be totally enclosed.

Refrigerant System

Refrigerant system shall include fixed orifice or TXV metering system.

Controls

Unit shall be complete with self-contained low voltage control circuit.

Approvals

Unit shall be UL listed as a total package for safety requirements. All wiring shall be in accordance with NEC.

Unit shall be rated in accordance with AHRI Standards 210/240.

Cabinet insulation shall conform to ASHRAE Standard 62.2

Insulation and adhesive shall meet NFPA 90A requirements for flame spread and smoke generation.

Unit shall have a sloped drain pan that conforms to ASHRAE Standard 62.2.

Accessories

Field-installed accessories shall include solid-state compressor short-cycle device, outdoor thermostat, room thermostats, electric heaters with single-point connection, crankcase heater, and low-ambient kit.