



Installation, Start-Up and Service Instructions

CONTENTS

	Page
SAFETY CONSIDERATIONS	1
GENERAL	2
INSTALLATION	2
Step 1 — Check Jobsite	2
Step 2 — Check Unit	2
Step 3 — Mount Unit	13
Step 4 — Make Electrical Connections	13
Step 5 — Install Supply and Return Piping	18
Hose Kits	18
Step 6 — Install Condensate Piping	18
PRE-START-UP	18
System Cleaning and Flushing	18
System Checkout	19
START-UP	21
Antifreeze	21
Cooling Tower/Boiler Systems	21
Ground Coupled, Closed Loop and Plateframe Heat Exchanger Well Systems	21
OPERATION	24
Sequence of Operation of Units Without DDC Controller	24
Unit Protection Module (UPM)	24
UPM Standard Safeties and Alarms	26
Units with Options	28
Sequence of Operation for Units with TruVu DDC Controller	28
Indoor Air Quality and Demand Control Ventilation ..	30
UNIT-MOUNTED CONTROLLER	33
MAINTENANCE	33
TROUBLESHOOTING	35
START-UP CHECKLIST	CL-1

IMPORTANT: Read the entire instruction manual before starting installation.

SAFETY CONSIDERATIONS

Installation and servicing of air-conditioning equipment can be hazardous due to system pressure and electrical components. Only trained and qualified service personnel should install, repair, or service air-conditioning equipment.

Untrained personnel can perform basic maintenance functions of cleaning coils and filters and replacing filters. All other operations should be performed by trained service personnel. When working on air-conditioning equipment, observe precautions in the literature, tags and labels attached to the unit, and other safety precautions that may apply.

Improper installation, adjustment, alteration, service, maintenance, or use can cause explosion, fire, electrical shock or other conditions which may cause personal injury or property damage. Consult a qualified installer, service agency, or your distributor for information or assistance. The qualified installer or service agency must use factory-authorized kits or accessories when modifying this product. Refer to the individual instructions packaged with the kits or accessories when installing.

Follow all safety codes. Wear safety glasses and work gloves. Use quenching cloth for brazing operations. Have fire extinguisher available. Read these instructions thoroughly and follow all warnings or cautions attached to the unit. Consult local building codes and applicable electrical codes for special installation requirements.



Refrigerant Safety Group A2L



⚠ WARNING

RISK OF FIRE

Flammable Refrigerant Used — To be repaired only by trained service personnel. DO NOT puncture refrigerant tubing.

⚠ WARNING

RISK OF FIRE

The appliance shall be stored in a room without continuously operating ignition sources (for example: open flames, an operating gas appliance or an operating electric heater).

⚠ WARNING

RISK OF FIRE

Flammable Refrigerant Used — Dispose of properly in accordance with federal or local regulations.

⚠ WARNING

Electrical shock can cause personal injury or death. Before installing or servicing system, always turn off main power to system. There may be more than one disconnect switch. Turn off accessory heater power if applicable.

⚠ WARNING

DO NOT USE TORCH to remove any component. System contains oil and refrigerant under pressure.

To remove a component, wear protective gloves and goggles and proceed as follows:

- a. Shut off electrical power to unit.
- b. Recover refrigerant to relieve all pressure from system using both high-pressure and low pressure ports.
- c. Traces of vapor should be displaced with nitrogen and the work area should be well ventilated. Refrigerant in contact with an open flame produces toxic gases.
- d. Cut component connection tubing with tubing cutter and remove component from unit. Use a pan to catch any oil that may come out of the lines and as a gauge for how much oil to add to the system.
- e. Carefully un-sweat remaining tubing stubs when necessary. Oil can ignite when exposed to torch flame.

Failure to follow these procedures may result in personal injury or death.

⚠ CAUTION

DO NOT re-use compressor oil or any oil that has been exposed to the atmosphere. Dispose of oil per local codes and regulations. DO NOT leave refrigerant system open to air any longer than the actual time required to service the equipment. Seal circuits being serviced and charge with dry nitrogen to prevent oil contamination when timely repairs cannot be completed. Failure to follow these procedures may result in damage to equipment.

GENERAL

The 50PEC water source heat pump (WSHP) console unit is a decentralized room terminal designed for field connection to a closed-circuit piping loop. See Fig. 1 for model number nomenclature details.

Units are typically installed in perimeter zones, usually under windows. Supply air is discharged directly into the conditioned space through discharge grilles located in the top of the unit.

IMPORTANT: The installation of console water source heat pump units and all associated components, parts, and accessories which make up the installation shall be in accordance with the regulations of ALL authorities having jurisdiction and MUST conform to all applicable codes. It is the responsibility of the installing contractor to determine and comply with ALL applicable codes and regulations.

INSTALLATION

Step 1 – Check Jobsite

Units are typically installed along an outside wall of the room. Refer to Fig. 2-9 for unit dimensions. Install units with adequate clearance to allow maintenance and servicing. See Table 1 for physical data. Locate the console unit so that it provides adequate air circulation throughout the room.

Installation, operation and maintenance instructions are provided with each unit. Before unit start-up, read all manuals and become familiar with the unit and its operation. Thoroughly check out the system before operation. Complete the inspections and instructions listed below to prepare a unit for installation.

1. Compare the electrical data on the unit nameplate with ordering and shipping information to verify that the correct unit has been shipped.

2. Keep both the chassis and cabinet covered with the shipping carton until all plastering, painting, and finish work is complete and it is time to install the chassis and cabinet.
3. Verify that the refrigerant tubing is free of kinks or dents, and that it does not touch other unit components.
4. Inspect all electrical connections. Connections must be clean and tight at the terminals.

⚠ CAUTION

To avoid equipment damage, do not use these units as a source of heating or cooling during the construction process. The mechanical components and filters used in these units quickly become clogged with construction dirt and debris which may cause system damage.

⚠ CAUTION

To avoid the release of refrigerant into the atmosphere, the refrigerant circuit of this unit must only be serviced by technicians who meet local, regional, and national proficiency requirements.

⚠ CAUTION

All refrigerant discharged from this unit must be recovered without exception. Technicians must follow industry accepted guidelines and all local, regional, and national statutes for the recovery and disposal of refrigerants.

⚠ CAUTION

When a compressor is removed from this unit, system refrigerant circuit oil will remain in the compressor. To avoid leakage of compressor oil, the refrigerant lines of the compressor must be sealed after it is removed.

Step 2 – Check Unit

Upon receipt of shipment at the jobsite, carefully check the shipment against the bill of lading. Make sure all units have been received. Inspect the carton or crating of each unit, and inspect each unit for damage. Ensure the shipping company makes proper notation of any shortages or damage on all copies of the freight bill. Concealed damage not discovered during unloading must be reported to the shipping company within 5 days of receipt of shipment.

NOTE: It is the responsibility of the purchaser to file all necessary claims with the shipping company.

STORAGE

⚠ CAUTION

DO NOT store or install console units in corrosive environments or in locations subject to temperature or humidity extremes (e.g., attics, garages, rooftops, etc.). Corrosive conditions and high temperature or humidity can significantly reduce performance, reliability, and service life. Always move units in an upright position. Tilting units on their sides may cause equipment damage.

Upon the arrival of equipment at the jobsite, immediately store units in their shipping cartons in a clean, dry area.

CAUTION

DO NOT stack units. Take care when moving the unit. The unit's weight is located on the left (compressor) end. Always store and move unit in an upright position. Take care to protect the unit cabinet and sub-base when moving or storing. Never move or lift unit by its water connections. Units must be moved and stored in an upright position, never lay the unit on it's side.

UNIT PROTECTION

Cover console units on the jobsite with either shipping cartons, vinyl film, or an equivalent protective covering. Cap the open ends

5 0 P E C 1 2 X X A E 3 G 1 A 1

Model Series (Pos 1-5)

50PEC – AQUAZONE High Efficiency Console Water Source Heat Pump

Nominal Capacity (Pos 6-7)

09 – 3/4 Tons
12 – 1 Tons
15 – 1-1/4 Tons
18 – 1-1/2 Tons

Water Circuit Options (Pos 8)

X – Left Hand Water Connection, 5/8" sweat connection
A – Right Hand Water Connection, 5/8" sweat connection
T – Left Hand Water Connection, 1/2" FPT Fittings
H – Right Hand Water Connection, 1/2" FPT Fittings

Cabinet and Subbase Options (Pos 9)

X – Standard 48" Cabinet and Sub-base
A – 63" Cabinet and Sub-base
T – No Cabinet and Standard Sub-base for 48" Cabinet
W – No Cabinet and No Sub-base

Control/Transformer Options (Pos 10)

A – Unit Protection Module (UPM)/40VA^a
B – Unit Protection Module (UPM)/75VA
E – UPM + TV DDC/75VA
G – UPM + Compressor Status Relay (SR), 40VA xfer^a
H – UPM + Compressor Status Relay (SR), 75VA xfer
J – UPM + Pump Relay (PR), 40VA xfer^a
K – UPM + Pump Relay (PR), 75VA xfer
L – UPM + EMS Relay (EMS), 40VA xfer^a
M – UPM + EMS Relay (EMS), 75VA xfer
U – UPM + SR + PR, 40VA xfer^a
V – UPM + SR + PR, 75VA xfer
W – UPM + EMS + SR, 40VA xfer^a
X – UPM + EMS + SR, 75VA xfer
Y – UPM + EMS + PR, 40VA xfer^a
Z – UPM + EMS + PR, 75VA xfer
1 – UPM + EMS + SR + PR, 40VA xfer^a
2 – UPM + EMS + SR + PR, 75VA xfer

CAUTION

When installing unit in cold air climates, an outside air damper must be provided to prevent possible condenser freeze-up.

Factory Installed Options (Pos 16)

1 – Cleanable Mesh Filter with Unit Mounted Controller
A – OA Damper and Cleanable Mesh Filter with Unit Mounted Controller
R – Cleanable Mesh Filter with Remote Thermostat
S – OA Damper and Cleanable Mesh Filter with Remote Thermostat

Operating Range (Pos 15)

A – Extended Range

Packaging (Pos 14)

1 – Single Pack, Domestic

Revision (Pos 13)

G – R-454B Refrigerant

Voltage (Pos 12)

3 – 208/230-1-60
4 – 265-1-60
C – 208/230-1-60 with Disconnect
D – 265-1-60 with Disconnect

Refrigerant Circuit Options (Pos 11)

E – Copper, Coated Coil (Epoxy)
J – CuNi, Coated Coil (Epoxy)

NOTE(S):

a. Standard transformer on 265-v units is 50VA.

LEGEND

CuNi — CuproNickel
EMS — EMS Relay
FPT — Female Pipe Thread
OA — Outdoor Air
PR — Pump Relay
SR — Compressor Status Relay
TV DDC — TruVu Direct Digital Controller
UMC — Unit Mounted Controller
UPM — Unit Protection Module

Fig. 1 – Model Number Nomenclature

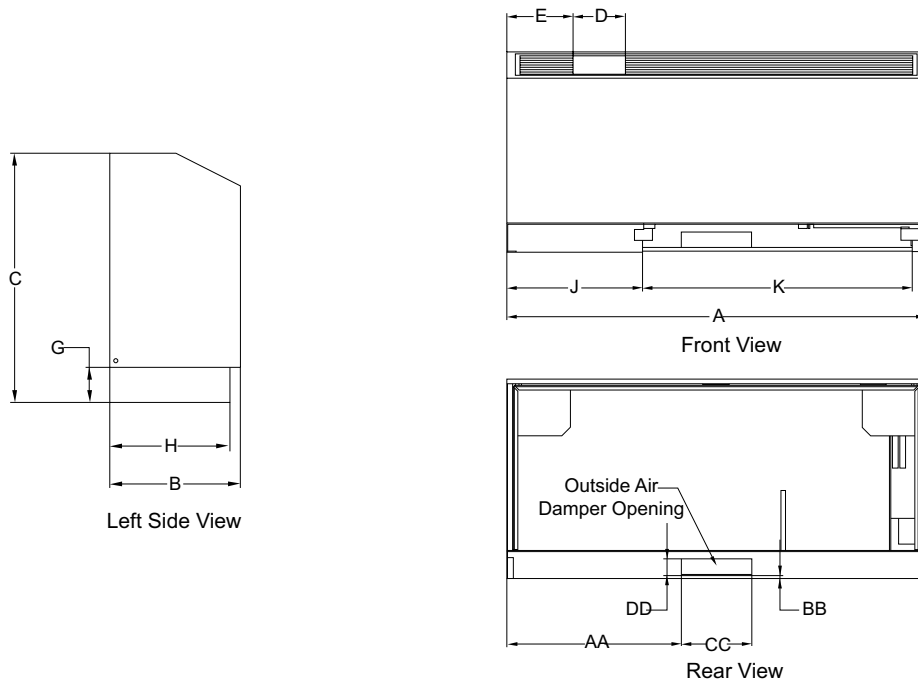

UNIT SIZE ^{a,b}	WATER CONNECTIONS	CABINET LENGTH	A	B	C	D	E	G	H	J	K
			Width	Depth	Height	Control Door Width	Cabinet End to Door	Clearance to Unit Bottom	Sub-Base Depth	Cabinet End to Return Air	Return Air Width
50PEC 009-018	LH	Std	48.00	12.00	24.00	6.00	7.13	3.50	11.00	15.50	30.75

UNIT SIZE	AA	BB	CC	DD	CONDENSER WATER CONNECTIONS (in.)	PERMANENT WASHABLE FILTER SIZE (in.)
	Cabinet End to Outside Air Damper Opening	Bottom to Outside Air Damper Opening	Outside Air Damper Opening Height	Outside Air Damper Opening Height		
50PEC 009-018	20.00	0.38	8.00	2.00	5/8 tube	30.25 x 7 x 0.375

NOTE(S):

- a. All dimensions in inches unless otherwise noted. All dimensions within ± 0.125 inch. Specifications subject to change without notice.
- b. Fresh air opening (in sub-base rear):
When installing unit in cold climates, an outside air damper must be provided to prevent possible condenser freeze-up.

Fig. 2 — 50PEC09-18 Unit Dimensions — Standard 48 in. Cabinet and Sub-base (Left Hand)

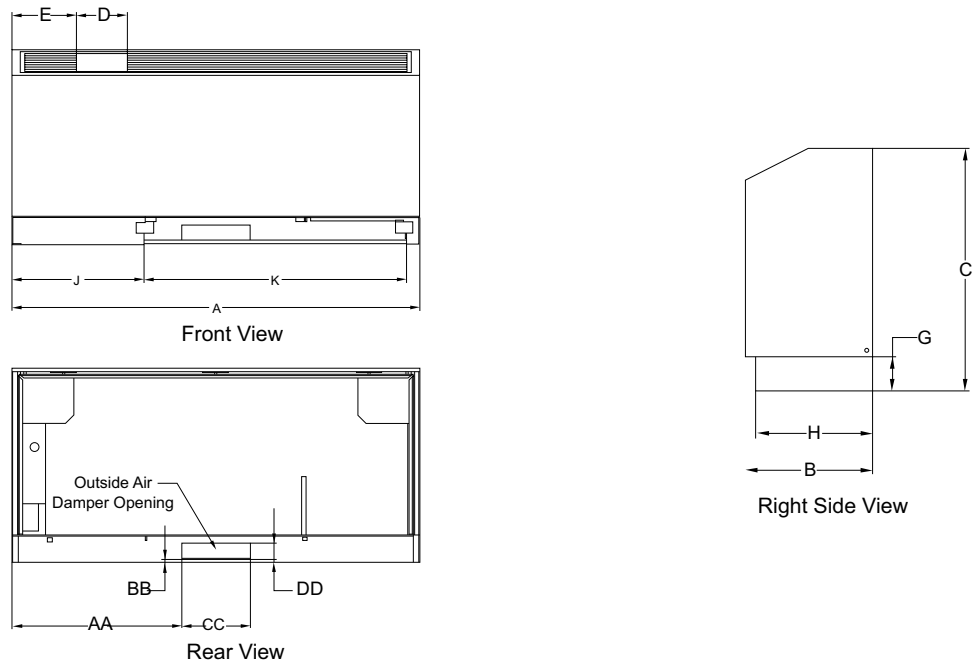

UNIT SIZE ^{a,b}	WATER CONNECTIONS	CABINET LENGTH	A	B	C	D	E	G	H	J	K
			Width	Depth	Height	Control Door Width	Cabinet End to Door	Clearance to Unit Bottom	Sub-Base Depth	Cabinet End to Return Air	Return Air Width
50PEC 009-018	RH	Std	48.00	12.00	24.00	6.00	3.88	3.50	11.00	13.25	30.75

UNIT SIZE	AA	BB	CC	DD	CONDENSER WATER CONNECTIONS (in.)	PERMANENT WASHABLE FILTER SIZE (in.)
	Cabinet End to Outside Air Damper Opening	Bottom to Outside Air Damper Opening	Outside Air Damper Opening Height	Outside Air Damper Opening Height		
50PEC 009-018	20.00	0.38	8.00	2.00	5/8 Tube	30.25 x 7 x 0.375

NOTE(S):

- a. All dimensions in inches unless otherwise noted. All dimensions within ± 0.125 inch. Specifications subject to change without notice.
- b. Fresh air opening (in sub-base rear):
When installing unit in cold climates, an outside air damper must be provided to prevent possible condenser freeze-up.

Fig. 3 — 50PEC09-18 Unit Dimensions — Standard 48 in. Cabinet and Sub-base (Right Hand)

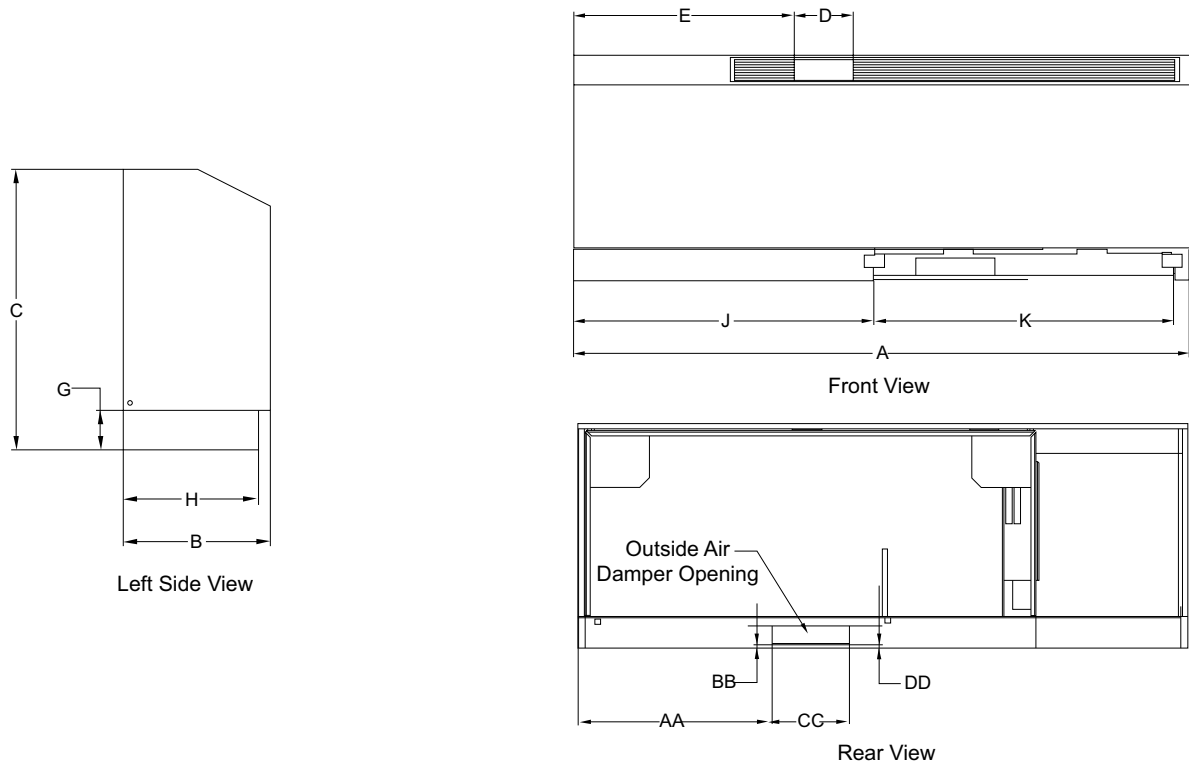

UNIT SIZE ^{a,b}	WATER CONNECTIONS	CABINET LENGTH	A	B	C	D	E	G	H	J	K
			Width	Depth	Height	Control Door Width	Cabinet End to Door	Clearance to Unit Bottom	Sub-Base Depth	Cabinet End to Return Air	Return Air Width
50PEC 009-018	LH	Ext	63.00	12.00	24.00	6.00	22.12	3.50	11.00	30.75	30.75

UNIT SIZE	AA	BB	CC	DD	CONDENSER WATER CONNECTIONS (in.)	PERMANENT WASHABLE FILTER SIZE (in.)
	Cabinet End to Outside Air Damper Opening	Bottom to Outside Air Damper Opening	Outside Air Damper Opening Height	Outside Air Damper Opening Height		
50PEC 009-018	20.00	0.38	8.00	2.00	5/8 tube	30.25 x 7 x 0.375

NOTE(S):

- a. All dimensions in inches unless otherwise noted. All dimensions within ± 0.125 inch. Specifications subject to change without notice.
- b. Fresh air opening (in sub-base rear):
When installing unit in cold climates, an outside air damper must be provided to prevent possible condenser freeze-up.

Fig. 4 – 50PEC09-18 Unit Dimensions – Extended 63 in. Cabinet and Sub-base (Left Hand)

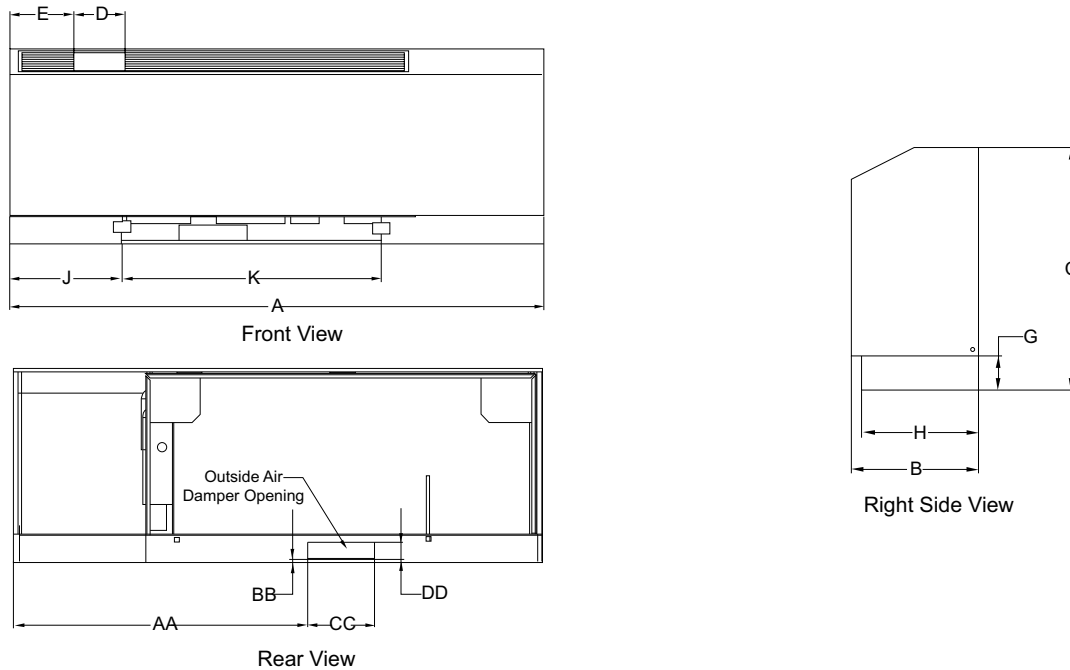

UNIT SIZE ^{a,b}	WATER CONNECTIONS	CABINET LENGTH	A	B	C	D	E	G	H	J	K
			Width	Depth	Height	Control Door Width	Cabinet End to Door	Clearance to Unit Bottom	Sub-Base Depth	Cabinet End to Return Air	Return Air Width
50PEC 009-018	RH	Ext	63.00	12.00	24.00	6.00	3.88	3.50	11.00	13.25	30.75

UNIT SIZE	AA	BB	CC	DD	CONDENSER WATER CONNECTIONS	PERMANENT WASHABLE FILTER SIZE
	Cabinet End to Outside Air Damper Opening	Bottom to Outside Air Damper Opening	Outside Air Damper Opening Height	Outside Air Damper Opening Height		
50PEC 009-018	35.00	0.38	8.00	2.00	5/8 in. tube	30.25 x 7 x 0.375

NOTE(S):

- All dimensions in inches unless otherwise noted. All dimensions within ± 0.125 inch. Specifications subject to change without notice.
- Fresh air opening (in sub-base rear):
When installing unit in cold climates, an outside air damper must be provided to prevent possible condenser freeze-up.

Fig. 5 — 50PEC09-18 Unit Dimensions — Extended 63 in. Cabinet and Sub-base (Right Hand)

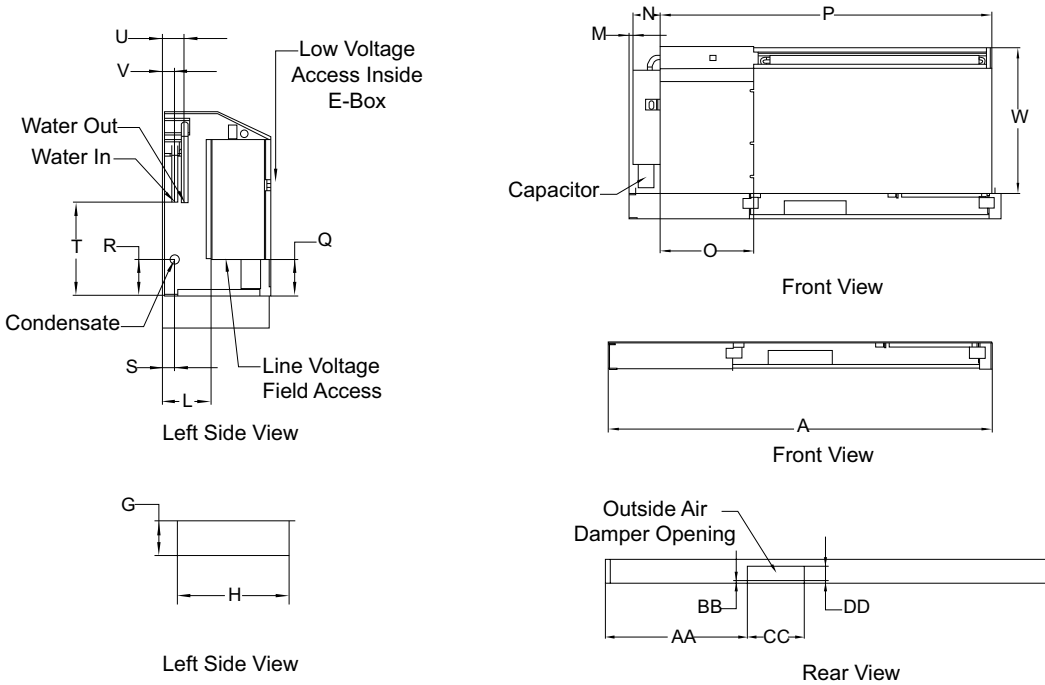

UNIT SIZE ^{a,b}	WATER CONNECTIONS	CABINET LENGTH	A	G	H	L	M	N	O	P	Q
			Width	Clearance to Unit Bottom	Sub-base Depth	Electrical Box to Back of Chassis	Sub-base End to Electrical Box	Electrical Box Width	Control Panel Width	Chassis Width	Electrical Box Height from Sub-base
50PEC 009-018	LH	Std	48.00	3.50	11.00	5.00	0.50	3.50	12.00	42.88	3.87

UNIT SIZE	R	S	T	U	V	W	AA	BB	CC	DD
	Condensate Height From Sub-base	Condensate Depth from Rear	Water Connection Height from Sub-base	Water Out Depth from Sub-base Rear	Water In Depth from Sub-base Rear	Chassis Height	Cabinet End to Outside Air Damper Opening	Bottom to Outside Air Damper Opening	Outside Air Damper Opening Width	Outside Air Damper Opening Height
50PEC 009-018	3.75	1.25	10.00	2.25	1.25	19.75	20.00	0.38	8.00	2.00

UNIT SIZE	CONDENSER WATER CONNECTIONS (in.)	PERMANENT WASHABLE FILTER SIZE (in.)
50PEC 009-018	5/8 tube	30.25 x 7 x 0.375

NOTE(S):

- a. All dimensions in inches unless otherwise noted. All dimensions within ± 0.125 inch. Specifications subject to change without notice.
- b. Fresh air opening (in sub-base rear):
When installing unit in cold climates, an outside air damper must be provided to prevent possible condenser freeze-up.

Fig. 6 — 50PEC09-18 Unit Dimensions — No Cabinet and Standard Sub-base for 48 in. Cabinet (Left Hand)

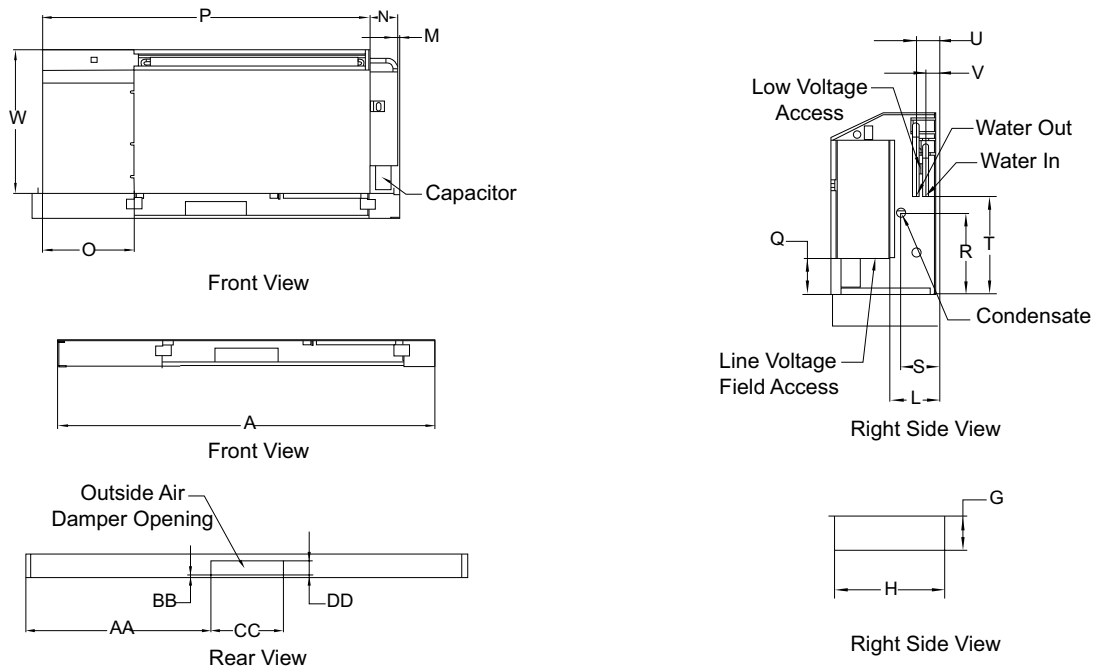

UNIT SIZE ^{a,b}	WATER CONNECTIONS	CABINET LENGTH	A	G	H	L	M	N	O	P	Q
			Width	Clearance to Unit Bottom	Sub-Base Depth	Electrical Box to Back of Chassis	Sub-base End to Electrical Box	Electrical Box Width	Control Panel Width	Chassis Width	Electrical Box Height from Sub-base
50PEC 009-018	RH	Std	48.00	3.50	11.00	5.00	0.38	3.50	12.00	42.88	3.87

UNIT SIZE	R	S	T	U	V	W	AA	BB	CC	DD
	Condensate Height from Sub-base	Condensate Depth from Rear	Water Connection Height from Sub-base	Water Out Depth from Sub-base Rear	Water In Depth from Sub-base Rear	Chassis Height	Cabinet End to Outside Air Damper Opening	Bottom to Outside Air Damper Opening	Outside Air Damper Opening Width	Outside Air Damper Opening Height
50PEC 009-018	8.75	4.00	10.00	2.25	1.25	19.75	20.00	0.38	8.00	2.00

UNIT SIZE	CONDENSER WATER CONNECTIONS (in.)	PERMANENT WASHABLE FILTER SIZE (in.)
50PEC 009-018	5/8 Tube	30.25 x 7 x 0.375

NOTE(S):

- a. All dimensions in inches unless otherwise noted. All dimensions within ± 0.125 inch. Specifications subject to change without notice.
- b. Fresh air opening (in sub-base rear):
When installing unit in cold climates, an outside air damper must be provided to prevent possible condenser freeze-up.

Fig. 7 — 50PEC09-18 Unit Dimensions — No Cabinet and Standard Sub-base for 48 in. Cabinet (Right Hand)

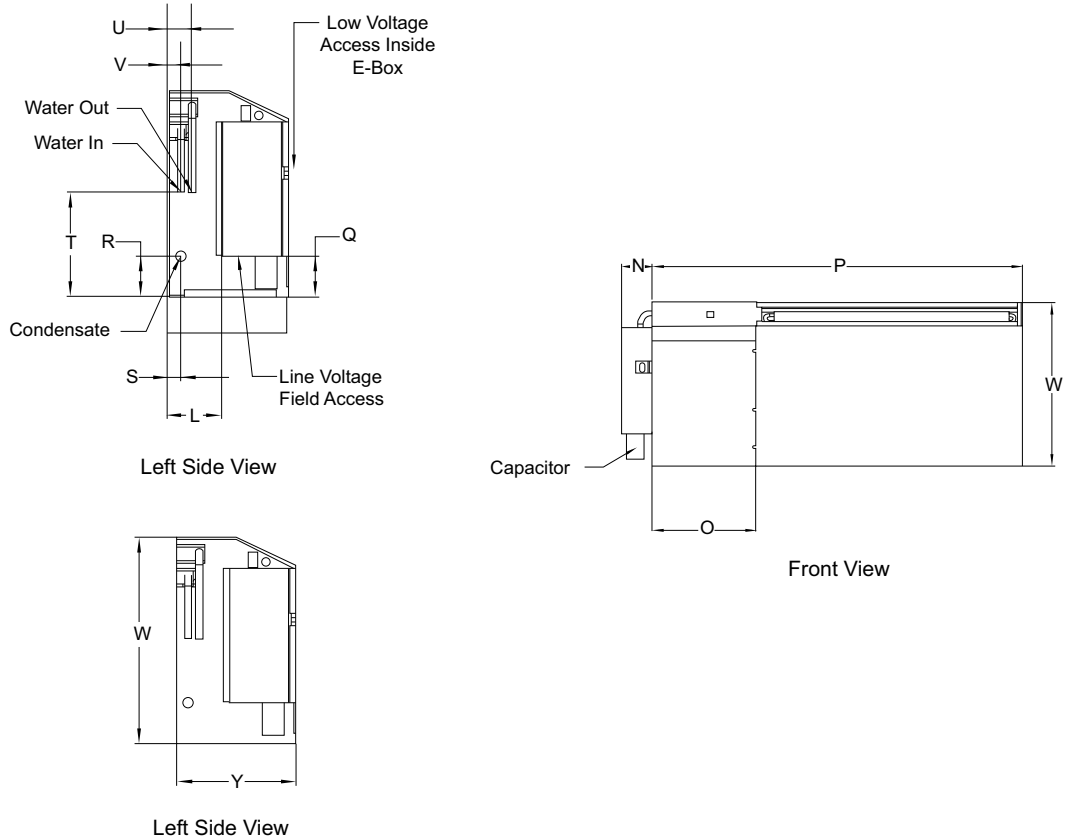

UNIT SIZE ^{a,b}	WATER CONNECTIONS	CABINET LENGTH	L	N	O	P	Q	R	S	T	U
			Width	Depth	Height	Control Door Width	Cabinet End to Door	Clearance to Unit Bottom	Sub-Base Depth	Cabinet End to Return Air	Return Air Width
50PEC 009-018	LH	—	5.00	3.50	12.00	42.88	3.87	3.75	1.25	10.00	2.25

UNIT SIZE	V	W	Y	CONDENSER WATER CONNECTIONS (in.)	PERMANENT WASHABLE FILTER SIZE (in.)
	Water In Depth from Sub-base Rear	Chassis Height	Chassis Depth		
50PEC 009-018	1.25	19.75	11.00	5/8 tube	—

NOTE(S):

- a. All dimensions in inches unless otherwise noted. All dimensions within ± 0.125 inch. Specifications subject to change without notice.
- b. When installing unit in cold climates, an outside air damper must be provided to prevent possible condenser freeze-up. Sub-base is not included.

Fig. 8 — 50PEC09-18 Unit Dimensions — No Cabinet and No Sub-base (Left Hand)

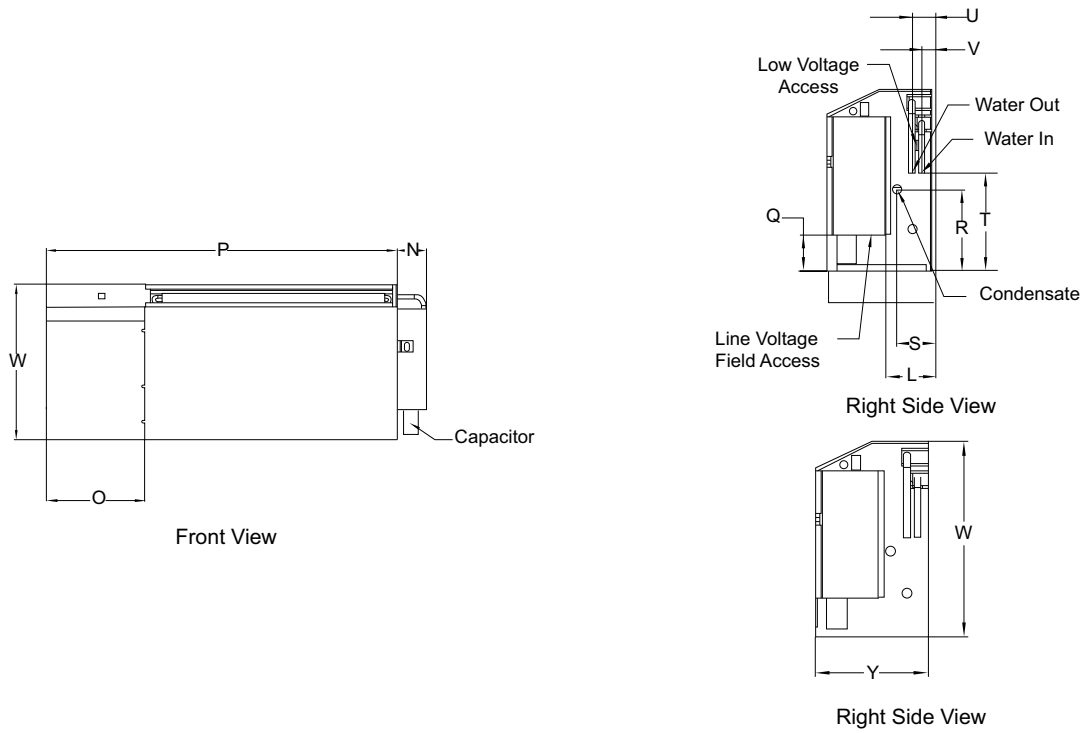

UNIT SIZE ^{a,b}	WATER CONNECTIONS	CABINET LENGTH	L	N	O	P	Q	R	S	T	U
			Electrical Box to Back of Chassis	Electrical Box Width	Control Panel Width	Chassis Width	Electrical Box Height from Sub-base	Condensate Height from Sub-base	Condensate Depth from Rear	Water Connection Height from Sub-base	Water Out Depth from Sub-base Rear
50PEC 009-018	RH	—	5.00	3.50	12.00	42.88	3.87	8.75	4.00	10.00	2.25

UNIT SIZE	V	W	Y	CONDENSER WATER CONNECTIONS (in.)	PERMANENT WASHABLE FILTER SIZE (in.)
	Water In Depth from Sub-base Rear	Chassis Height	Chassis Depth		
50PEC 009-018	1.25	19.75	11.00	5/8 Tube	—

NOTE(S):

- a. All dimensions in inches unless otherwise noted. All dimensions within ± 0.12 inch. Specifications subject to change without notice.
- b. When installing unit in cold climates, an outside air damper must be provided to prevent possible condenser freeze-up. Sub-base is not included.

Fig. 9 — 50PEC09-18 Unit Dimensions — No Cabinet and No Sub-base (Right Hand)

Table 1 — Physical Data

50PEC UNIT SIZE	009	012	015	018
COMPRESSOR TYPE (QTY 1)	Rotary	Rotary	Rotary	Rotary
Refrigeration Charge (oz)	21.5	23	26	24.5
Max Water Working Pressure (psig/kPa)	450 / 3100	450 / 3100	450 / 3100	450 / 3100
Number of Refrigeration Circuits	1	1	1	1
EVAPORATOR COIL				
Coil Type	Tube-Fin	Tube-Fin	Tube-Fin	Tube-Fin
Air Coil Dimensions (H x L)	10 x 27	10 x 27	10 x 27	10 x 27
Row(s)	2	2	3	3
MOTOR & BLOWER				
Fan Motor Type/Speeds	PSC/2	PSC/2	PSC/2	PSC/2
Fan Motor (HP)	1/10	1/4	1/4	1/4
Blower Wheel Size (Dia. x W)	5.5 x 8 (2)	5.5 x 8 (2)	5.5 x 8 (2)	5.5 x 8 (2)
WATER CONNECTION				
Type	Sweat / FPT Option	Sweat / FPT Option	Sweat / FPT Option	Sweat / FPT Option
Size (in.)	5/8 / 1/2	5/8 / 1/2	5/8 / 1/2	5/8 / 1/2
Water Coil Type	Coaxial	Coaxial	Coaxial	Coaxial
Coaxial Coil Water Volume (gal)	0.08	0.11	0.11	0.11
Condensate Connection (in.)	5/8	5/8	5/8	5/8
CABINET				
Standard Filter - 1/2 in. Washable Aluminum (H x L)	7 x 31-1/4 x 3/8	7 x 31-1/4 x 3/8	7 x 31-1/4 x 3/8	7 x 31-1/4 x 3/8
Weight - Operating (lb)	131	138	144	144
Weight - Shipping (lb)	151	158	164	164

LEGEND

FPT — Female Pipe Thread
PSC — Permanent Split Capacitor

Step 3 – Mount Unit

1. Before installing the unit, examine each pipe, fitting and valve; remove any dirt or debris found on or in these components. Use care when installing the system components to avoid damage to the cabinet finish or chassis.
2. After removing the console unit from its packaging remove the cabinet by removing the cabinet screws on either side of the unit and lifting the cabinet off the chassis. Set the cabinet aside and cover it (the console unit's packaging can be used for this purpose).
3. Position the sub-base directly on the finished floor. Make sure the sub-base is level (use shims if necessary). The sub-base has a frame that supports the cabinet and must be secured to wall or other structure.
4. Position the chassis onto the sub-base. Check and align electrical, water and condensate connections and secure to the sub-base with 4 screws.
5. Make sure the unit's washable filter is clean and installed in the sub-base. Also make sure that the filter clip is in place.
6. Reinstall the unit cabinet via locating pins at the top of the chassis and two screws in the unit sub-base.

Step 4 – Make Electrical Connections

⚠ WARNING

To avoid possible injury or death due to electrical shock, open the power supply disconnect switch and secure it in an open position during installation.

⚠ CAUTION

Use only copper conductors for field-installed electrical wiring. Unit terminals are not designed to accept other types of conductors.

Field wiring must comply with local and national fire, safety and electrical codes. Power to the unit must be within the operating voltage range indicated on the unit chassis nameplate or the performance data sheet. For electrical data see Table 2. Properly sized fuses or HACR (Heating, Air Conditioning and Refrigeration) breakers must be installed for branch circuit protection. See unit chassis nameplate for maximum size.

Each chassis is supplied with a 2 x 4 in. junction box for power connection. Inside this box there are 2 pigtail leads for power wiring. The field ground is to be connected to the ground connection on the junction box. On remote thermostat and primary/secondary units there are also 5-position terminal blocks for low voltage thermostat or secondary unit connection. On remote thermostat units, connect the thermostat wires to the low voltage terminal block. On primary/secondary units connect the thermostat to the "Primary" terminal block of the lead unit and the "Secondary" terminal block to the "Primary" terminal block of the next unit, daisy chaining the units together as required. Note that there is no limit to the number of units that can be connected together in this manner as each unit provides its own low voltage power supply. For wiring diagrams, see Fig. 10-13.

NOTE: All 208/230 volt (voltage code -1) units are factory wired to 230 volts unless ordered otherwise. In 208 volt applications the transformer wiring may need to be switched from the 230 volt tap to the 208 volt tap. Cap all unused leads.

Table 2 – Electrical Data – 50PEC Units With or Without Disconnect

50PEC MODELS	RATED VOLTAGE	VOLTAGE MIN/MAX	COMPRESSOR			BLOWER MOTOR		TOTAL UNIT FLA	MCA	MOP	COMPRESSOR SERVICE		
			Qty	RLA	LRA	FLA	Hp				Cold Winding Resistance (Ω)		Run Capacitor (µF/V)
											Single Phase: R-C	Single Phase: S-C	
009	208-230/1/60	197/253	1	3.2	22.2	0.9	0.10	4.1	4.9	15	2.95	7.35	15/370
	265-277/1/60	239/291	1	2.6	18.8	0.7	0.10	3.3	4.0	15	4.27	10.74	10/440
012	208-230/1/60	197/253	1	4.4	27.9	0.8	0.25	5.2	6.3	15	2.32	5.93	20/370
	265-277/1/60	239/291	1	3.5	22.2	0.8	0.25	4.3	5.2	15	3.47	8.69	15/440
015	208-230/1/60	197/253	1	5.2	29.0	0.8	0.25	6.0	7.3	15	2.31	5.45	25/450
	265-277/1/60	239/291	1	4.2	20.0	0.8	0.25	5.0	6.1	15	3.58	7.39	15/440
018	208-230/1/60	197/253	1	7.3	39.0	0.8	0.25	8.1	9.9	15	1.97	1.42	50/440
	265-277/1/60	239/291	1	5.8	31.0	0.8	0.25	6.6	8.1	15	2.54	1.87	30/440

LEGEND

- FLA — Full Load Amps
- Hp — Horsepower
- MCA — Minimum Circuit Amps
- MOP — Maximum Overcurrent Protection
- LRA — Locked Rotor Amps
- RLA — Rated Load Amps

FAN MOTOR SPEED TABS - 3 POLE MOTORS			
UNIT	HI	LO	CAPPED
009	BLU	RED	BLK
012	BLU	RED	BLK
015	BLU	RED	BLK
018	BLK	RED	BLU

FAN MOTOR SPEED TABS - 4 POLE MOTORS				
UNIT	HI	LO	CAPPED	CAPPED
009	ORG	RED	BLK	BLU
012	BLU	ORG	BLK	RED
015	BLK	ORG	BLU	RED
018	BLK	BLU	ORG	RED

FACTORY WIRE _____
FIELD WIRE - - - - -

STANDARD COMPONENTS LEGEND:

- BC - BLOWER MOTOR CAPACITOR
- BM - BLOWER MOTOR
- CAP - COMPRESSOR CAPACITOR
- CC - COMPRESSOR CAPACITOR
- CS - CONDENSATE SENSOR
- EOVD - EXTERNAL OVERLOAD
- FS - FREEZE SENSOR
- HPS - HIGH PRESSURE SWITCH
- HSR - HIGH PRESSURE RELAY
- HSR - HIGH SPEED RELAY (BLOWER MOTOR)
- LPS - LOW PRESSURE SWITCH
- LPR - LOW PRESSURE RELAY
- LSR - LOW SPEED RELAY (BLOWER MOTOR)
- RV - REVERSING VALVE (HEAT PUMPS)
- TS - TEMPERATURE SENSOR
- Y1R - Y1 CALL RELAY

OPTIONAL COMPONENTS LEGEND:

- [] AUX - AUXILIARY RELAY (FOR LOOP PUMP, ETC)
- [] CBR - 24 VAC CIRCUIT BREAKER
- [] CMR - COMPR. MONITOR RELAY
- [] DS - DISCONNECT SWITCH
- [] EMS - ENERGY MGMT SYSTEM RELAY
- [] OAD - OUTSIDE AIR DAMPER INCLUDES:
 - DAMPER MTR (OAD)
 - DAMPER SWITCH (DMS)

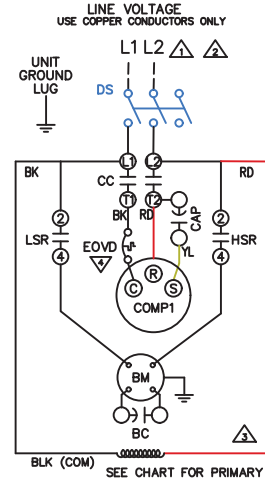

NOTES:

- SEE UNIT NAME PLATE FOR ELECTRICAL RATING
- ALL FIELD WIRING MUST BE IN ACCORDANCE WITH N.E.C.-N.F.P.A. #70, COPPER CONDUCTORS ONLY. CONDUCTEURS EN CUIVRE SEULEMENT.
- 208/230V UNITS ARE FACTORY WIRED FOR 230V OPERATION. FOR 208V OPERATION, REMOVE 240V LEAD AND CONNECT IT TO 208V. CAP ALL UNUSED LEADS.
- EXTERNAL OVERLOAD STANDARD ON ALL UNITS EQUIPPED WITH ROTARY COMPRESSORS.
- FOR ALTERNATE EMS COIL VOLTAGES CONSULT FACTORY.
- UPM-1 INCLUDES BUILT IN:
 - 270-300 SECOND RANDOM START
 - 300 SECOND DELAY ON BREAK
 - 120 SECOND LOW PRESSURE BYPASS
 - 120 SECOND FREEZE PROTECTION BYPASS
- "TEST" DIP SWITCH REDUCES DELAYS TO 10 SEC WHEN SET TO "YES". MUST BE SET TO "NO" FOR NORMAL OPERATION.
- "FREEZE SENSOR" ON CONDENSER WILL BE SET TO 25F BY DEFAULT. IF 15F OPERATION IS REQUIRED, MOVE DIP SWITCH SLIDER TO THE 15F POSITION.
- "ALARM OUTPUT" DIP SWITCH MUST BE SET TO "PULSE" IF BLINKING T-STAT SERVICE LIGHT IS DESIRED.
- DEFAULT SETTINGS FOR UPM BOARD FROM FACTORY SHOWN. ALSO SEE INSTALLATION MANUAL.
- ALARM OUTPUT IS NORMALLY OPEN (NO) DRY CONTACT. IF 24 VAC IS NEEDED, CONNECT R FROM TERMINAL BLOCK TO ALR-COM TERMINAL. 24VAC WILL BE SENSED ON THE ALR-OUT WHEN THE UNIT IS IN ALARM CONDITION. OUTPUT WILL BE PULSED IF PULSE IS SELECTED.
- SERVICE LIGHT WILL BLINK ONCE ON CONTROL PANEL FOR A HIGH PRESSURE LOCKOUT.
- SERVICE LIGHT WILL BLINK TWICE ON CONTROL PANEL FOR A LOW PRESSURE LOCKOUT.
- LOCKOUTS CAN BE RESET BY CYCLING THE CONTROLLER OFF WITH THE (MODE) BUTTON.
- IF POWER IS CYCLED TO THE UNIT, THE CONTROL PANEL MAY NEED TO BE REPROGRAMMED.
- "LOCKOUT" DIP SWITCH MUST BE SET TO "2" FOR PROPER SIMULTANEOUS UMC AND UPM OPERATION.

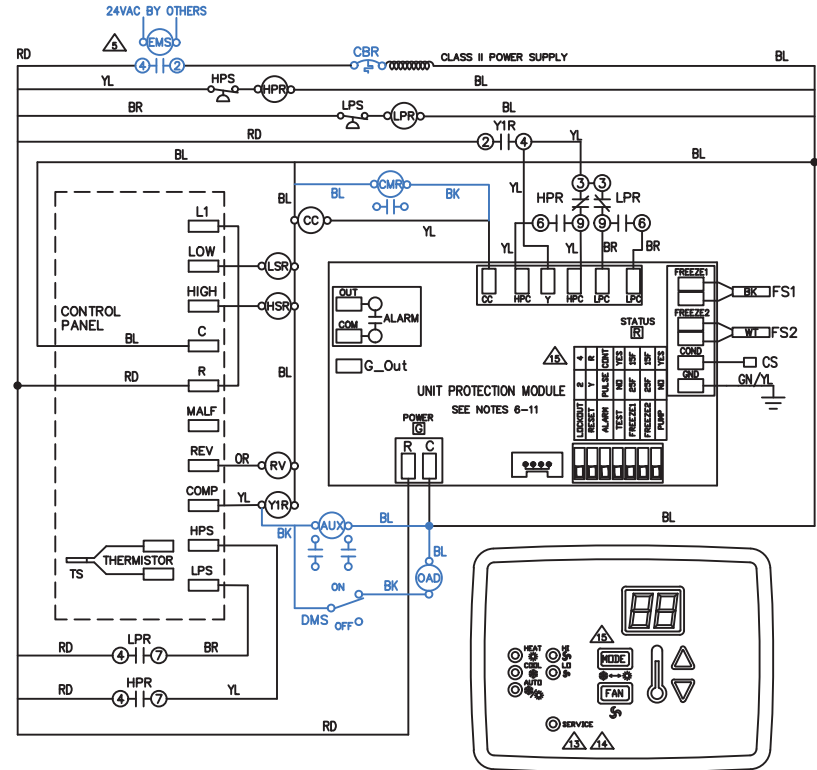

PROGRAMMING INSTRUCTIONS:
TO PROGRAM THE CONTROLLER'S USER CONFIGURABLE FEATURES PRESS THE TEMPERATURE UP AND DOWN ARROW BUTTONS SIMULTANEOUSLY AND HOLD FOR 5 SECONDS. THIS WILL PUT THE CONTROLLER IN THE CONFIGURATION MODE.

USE THE (MODE) BUTTON TO SELECT THE FEATURE TO BE CONFIGURED: FARENHEIT/CELCIUS (F/C), TEMPERATURE DIFFERENTIAL, TIME DELAY/NO TIME DELAY (dE/nd), CYCLING FAN/CONSTANT FAN (CY/CO).

ONCE THE DESIRED FEATURE IS SELECTED, USE THE ARROW BUTTONS TO ADJUST IT. THE CONTROLLER WILL REVERT TO NORMAL OPERATION AFTER 5 SECONDS OF NO ACTIVITY.

UPM STATUS LED - BLINK CODES	
1	HIGH PRESSURE FAULT
2	LOW PRESSURE FAULT
3	CONDENSER FREEZE CONDITION
4	CONDENSATE OVERFLOW FAULT
5	BROWN OUT FAULT
6	EVAPORATOR FREEZE CONDITION
7	REFRIGERANT LEAKAGE

COLOR CHART LEGEND	
ABBREVIATION	COLOR
BK	BLACK
BL	BLUE
BN	BROWN
GY	GRAY
GN	GREEN
OG	ORANGE
RD	RED
VT	VIOLET
WT	WHITE
YL	YELLOW

8 733 838 283 REV 2

Fig. 10 — Wiring Diagram with Unit Mounted Controller, Options (EMS, Pump Relay, OAD, Compressor Status Relay)

UPM STATUS LED - BLINK CODES	
1	HIGH PRESSURE FAULT
2	LOW PRESSURE FAULT
3	CONDENSER FREEZE CONDITION
4	CONDENSATE OVERFLOW FAULT
5	BROWN OUT FAULT
6	EVAPORATOR FREEZE CONDITION
7	REFRIGERANT LEAKAGE

COLOR CHART LEGEND	
ABBREVIATION	COLOR
BK	BLACK
BL	BLUE
BN	BROWN
GY	GRAY
GN	GREEN
OG	ORANGE
RD	RED
VT	VIOLET
WT	WHITE
YL	YELLOW

FACTORY WIRE _____
FIELD WIRE - - - - -

- STANDARD COMPONENTS LEGEND:**
- BC - BLOWER MOTOR CAPACITOR
 - BM - BLOWER MOTOR
 - CAP - COMPRESSOR CAPACITOR
 - CC - COMPRESSOR CONTACTOR
 - CS - CONDENSATE SENSOR (IN DRAIN PAN)
 - EOVD - EXTERNAL OVERLOAD
 - FS - FREEZE SENSOR
 - FSC - FAN SPEED CONTROL (SWITCH)
 - HPS - HIGH PRESSURE SWITCH
 - HSR - HIGH SPEED RELAY (BLOWER)
 - LPS - LOW PRESSURE SWITCH
 - LSR - LOW SPEED RELAY (BLOWER)
 - RV - REVERSING VALVE (HEAT PUMPS)

- OPTIONAL COMPONENTS LEGEND:**
- [] AUX - AUXILIARY RELAY (FOR LOOP PUMP, ETC)
 - [] CBR - 24V CIRCUIT BREAKER
 - [] CMR - COMPRESSOR MONITOR RELAY
 - [] DS - DISCONNECT SWITCH
 - [] EMS - ENERGY MGMT SYSTEM RELAY
 - [] OAD - OUTSIDE AIR DAMPER INCLUDES:
- DAMPER MTR (OAD)
- DAMPER SWITCH (DMS)

- NOTES:**
- SEE UNIT NAME PLATE FOR ELECTRICAL RATING.
 - ALL FIELD WIRING MUST BE IN ACCORDANCE WITH N.E.C.-N.F.P.A. #70, COPPER CONDUCTORS ONLY. - CONDUCTEURS EN CUIVRE SEULEMENT.
 - 208/230V UNITS ARE FACTORY WIRED FOR 230V OPERATION. FOR 208V OPERATION, REMOVE ORG LEAD AND REPLACE WITH RED LEAD. CAP ALL UNUSED LEADS.
 - EXTERNAL OVERLOAD STANDARD ON ALL UNITS EQUIPPED WITH ROTARY COMPRESSORS.
 - FOR ALTERNATE EMS COIL VOLTAGES CONSULT FACTORY.
 - UPM-I INCLUDES BUILT IN:
270-300 SECOND RANDOM START
300 SECOND DELAY ON BREAK
120 SECOND LOW PRESSURE BYPASS
120 SECOND FREEZE PROTECTION BYPASS
 - "TEST" DIP SWITCH REDUCES DELAYS TO 10 SEC WHEN SET TO YES. MUST BE SET TO "NO" FOR NORMAL OPERATION.
 - "FREEZE SENSOR" ON CONDENSER WILL BE SET TO 25°F BY DEFAULT. IF 15°F OPERATION IS REQUIRED, MOVE DIP SWITCH SLIDER TO THE 15°F POSITION. "ALARM OUTPUT" DIP SWITCH MUST BE SET TO "PULSE" IF BLINKING T-STAT SERVICE LIGHT IS DESIRED.
 - DEFAULT SETTINGS FOR UPM BOARD FROM FACTORY SHOWN. ALSO SEE INSTALLATION MANUAL.
 - ALARM OUTPUT IS NORMALLY OPEN (NO) DRY CONTACT. IF 24 VAC IS NEEDED, CONNECT R FROM THERMOSTAT TERMINAL BLOCK TO ALR-COM TERMINAL. 24VAC WILL BE SENSED ON THE ALR-OUT WHEN THE UNIT IS IN ALARM CONDITION. OUTPUT WILL BE PULSED IF PULSE IS SELECTED.

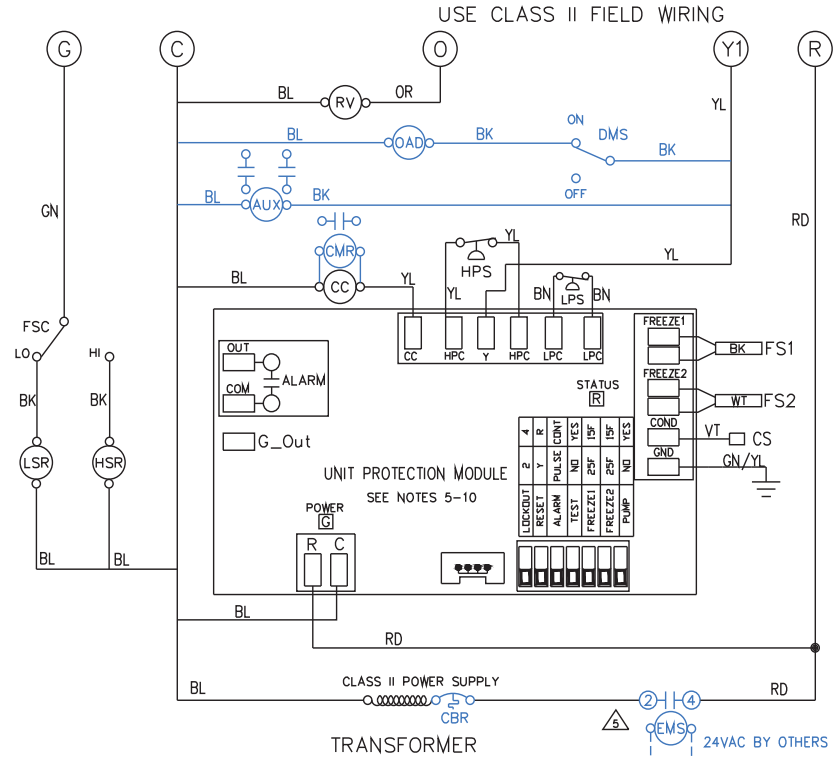
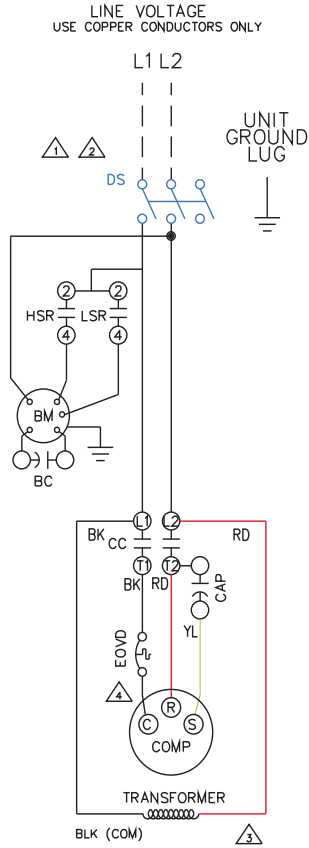

FAN MOTOR SPEED TABS - 4 POLE MOTORS				
UNIT	HI	LO	CAPPED	CAPPED
009	ORG	RED	BLK	BLU
012	BLU	ORG	BLK	RED
015	BLK	ORG	BLU	RED
018	BLK	BLU	ORG	RED

FAN MOTOR SPEED TABS - 3 POLE MOTORS			
UNIT	HI	LO	CAPPED
009	BLU	RED	BLK
012	BLU	RED	BLK
015	BLU	RED	BLK
018	BLK	RED	BLU

8 733 838 284 REV 2

Fig. 11 — PSC Motor, Single Phase/Single Stage and Options (EMS, Pump Relay, OAD, Compressor Status Relay)

UPM STATUS LED - BLINK CODES	
1	HIGH PRESSURE FAULT
2	LOW PRESSURE FAULT
3	CONDENSER FREEZE CONDITION
4	CONDENSATE OVERFLOW FAULT
5	BROWN OUT FAULT
6	EVAPORATOR FREEZE CONDITION
7	REFRIGERANT LEAKAGE

COLOR CHART LEGEND	
ABBREVIATION	COLOR
BK	BLACK
BL	BLUE
BN	BROWN
CY	GRAY
GN	GREEN
OG	ORANGE
RD	RED
VT	VIOLET
WT	WHITE
YL	YELLOW

FACTORY WIRE ———
FIELD WIRE - - - - -

STANDARD COMPONENTS LEGEND:

- BC - BLOWER MOTOR CAPACITOR
- BM - BLOWER MOTOR
- CAP - COMPRESSOR CAPACITOR
- CC - COMPRESSOR CONTACTOR
- CS - CONDENSATE SENSOR (IN DRAIN PAN)
- EOVD - EXTERNAL OVERLOAD
- FS - FREEZE SENSOR
- FSC - FAN SPEED CONTROL (SWITCH)
- HPS - HIGH PRESSURE SWITCH
- HSR - HIGH SPEED RELAY (BLOWER)
- LPS - LOW PRESSURE SWITCH
- LSR - LOW SPEED RELAY (BLOWER)
- RV - REVERSING VALVE (HEAT PUMPS)

OPTIONAL COMPONENTS LEGEND:

- [] CBR - 24V CIRCUIT BREAKER
- [] DS - DISCONNECT SWITCH
- [] OAD - OUTSIDE AIR DAMPER INCLUDES:
- DAMPER MTR (OAD)
- DAMPER SWITCH (DMS)

NOTES:

- SEE UNIT NAME PLATE FOR ELECTRICAL RATING.
- ALL FIELD WIRING MUST BE IN ACCORDANCE WITH N.E.C.-N.F.P.A. #70, COPPER CONDUCTORS ONLY. - CONDUCTEURS EN CUIVRE SEULEMENT.
- 208/230V UNITS ARE FACTORY WIRED FOR 230V OPERATION. FOR 208V OPERATION, REMOVE ORG LEAD AND REPLACE WITH RED LEAD. CAP ALL UNUSED LEADS.
- EXTERNAL OVERLOAD STANDARD ON ALL UNITS EQUIPPED WITH ROTARY COMPRESSORS.
- UPM-1 INCLUDES BUILT IN:
270-300 SECOND RANDOM START
300 SECOND DELAY ON BREAK
120 SECOND LOW PRESSURE BYPASS
120 SECOND FREEZE PROTECTION BYPASS
- "TEST" DIP SWITCH REDUCES DELAYS TO 10 SEC WHEN SET TO YES. MUST BE SET TO "NO" FOR NORMAL OPERATION.
- "FREEZE SENSOR" ON CONDENSER WILL BE SET TO 25°F BY DEFAULT. IF 15°F OPERATION IS REQUIRED, MOVE DIP SWITCH SLIDER TO THE 15°F POSITION. "ALARM OUTPUT" DIP SWITCH MUST BE SET TO "PULSE" IF BLINKING T-STAT SERVICE LIGHT IS DESIRED.
- DEFAULT SETTINGS FOR UPM BOARD FROM FACTORY SHOWN. ALSO SEE INSTALLATION MANUAL.
- ALARM OUTPUT IS NORMALLY OPEN (NO) DRY CONTACT. IF 24 VAC IS NEEDED, CONNECT R FROM THERMOSTAT TERMINAL BLOCK TO ALR-COM TERMINAL, 24VAC WILL BE SENSED ON THE ALR-OUT WHEN THE UNIT IS IN ALARM CONDITION. OUTPUT WILL BE PULSED IF PULSE IS SELECTED.

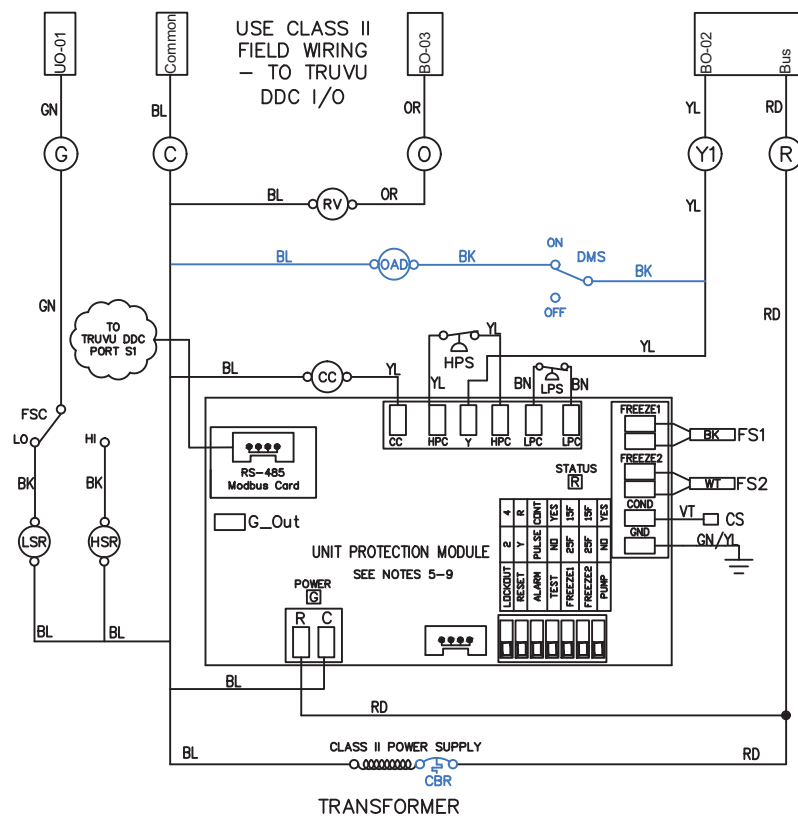
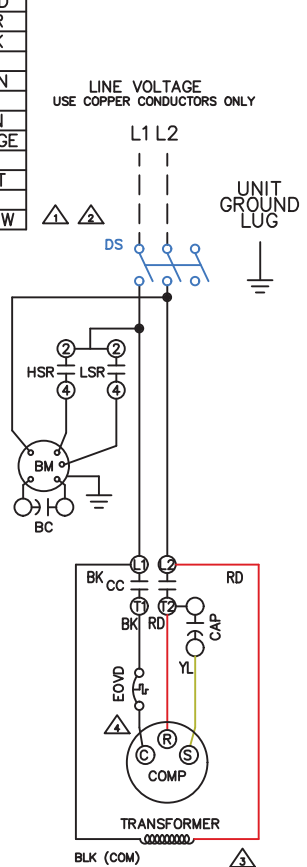

FAN MOTOR SPEED TABS - 4 POLE MOTORS				
UNIT	HI	LO	CAPPED	CAPPED
009	ORG	RED	BLK	BLU
012	BLU	ORG	BLK	RED
015	BLK	ORG	BLU	RED
018	BLK	BLU	ORG	RED

FAN MOTOR SPEED TABS - 3 POLE MOTORS			
UNIT	HI	LO	CAPPED
009	BLU	RED	BLK
012	BLU	RED	BLK
015	BLU	RED	BLK
018	BLK	RED	BLU

8 733 838 285 REV 3

Fig. 12 — PSC Motor, Single Phase/Single Stage, TruVu™ DDC

FACTORY INSTALLED COMPONENTS (OUTPUTS):

UO-1 - UNIVERSAL OUTPUT 1:
 G1 - FAN ON (PSC & CT ECM)
 ECM - FAN MODULATION (CA ECM PWM)
 VFD - FAN MODULATION (VFD 0-10VDC)

AO-2 - ANALOG OUTPUT 2:
 MRV - MODULATING REHEAT VALVE

BO-2 - BINARY OUTPUT 2:
 Y1 - COMPRESSOR

BO-3 - BINARY OUTPUT 3:
 O - REVERSING VALVE

BO-4 - BINARY OUTPUT 4:
 Y2 - COMPRESSOR (TWO STAGE/SPEED)
 WSE - WATER-SIDE ECONOMIZER VALVE (SINGLE STAGE)
 W1 - AUX HEAT 1ST STAGE (SINGLE STAGE)

BO-5 - BINARY OUTPUT 5:
 H - DEHUMIDIFICATION (HGRH)
 W1 - AUX HEAT 1ST STAGE (SINGLE OR TWO STAGE/SPEED)

BO-6 - BINARY OUTPUT 6:
 G2 - FAN ON (CT ECM)
 WSE - WATER-SIDE ECONOMIZER VALVE (TWO STAGE)
 W2 - AUX HEAT 2ND STAGE (TWO STAGE/SPEED)

BO-7 - BINARY OUTPUT 7:
 G3 - FAN ON (CT ECM)
 VFD - VFD ENABLE/DISABLE

STANDARD FACTORY INSTALLED COMPONENTS (INPUTS):

IN-2 - UNIVERSAL INPUT 2:
 LWTS - LEAVING WATER TEMPRATURE SENSOR

IN-3 - UNIVERSAL INPUT 3:
 EWTS - ENTERING WATER TEMPRATURE SENSOR

STANDARD FACTORY PROVIDED COMPONENTS (INPUTS):

IN-1 - UNIVERSAL INPUT 1:
 SATS - SUPPLY AIR TEMPRATURE SENSOR

IN-6 - UNIVERSAL INPUT 6:
 RATS - RETURN AIR TEMPRATURE SENSOR

OPTIONAL FACTORY INSTALLED COMPONENTS (INPUTS):

IN-7 - UNIVERSAL INPUT 7:
 DPS - DIFFERENTIAL PRESSURE SWITCH

OPTIONAL FIELD INSTALLED COMPONENTS (INPUTS):

IN-6 - UNIVERSAL INPUT 6:
 SPT - SPACE TEMPRETURE SENSOR

IN-7 OR 8 - UNIVERSAL INPUT 7 OR 8:

EMSD - EMERGENCY SHUTDOWN
 OCC - REMOTE OCCUPANCY
 SCO - SECONDARY CONDENSATE OVERFLOW
 FS - FLOW SWITCH
 FM - WATER FLOW METER

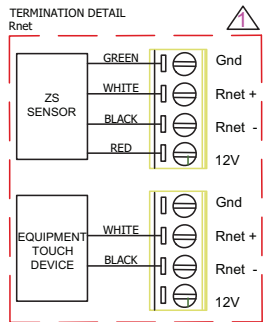
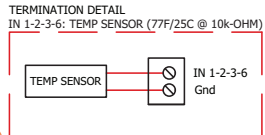
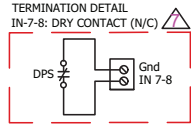

FACTORY WIRE _____
 FIELD WIRE - - - - -

- 1 EQUIPMENT TOUCH DEVICE OR OPTIONAL ZS COMBINATION WALL SENSOR CAPABLE OF TEMPERATURE, HUMIDITY, AND CO2 READINGS.
- 2 OPTIONAL MODULATING REHEAT VALVE (MRV)
- 3 **TWO STAGE/SPEED UNITS:** BO-4 IS ONLY AVAILABLE FOR OUTPUT SIGNAL (Y2)
SINGLE STAGE/SPEED UNITS: BO-4 IS AVAILABLE FOR WSE
- 4 H SIGNAL IS USED ON REHEAT APPLICATIONS
- 5 **TWO STAGE/SPEED UNITS:** BO-6 IS AVAILABLE FOR WSE OUTPUT SIGNAL
SINGLE STAGE/SPEED UNITS: BO-6 IS AVAILABLE FOR FAN ON G2 OUTPUT SIGNAL
- 6 IN-07 UTILIZED FOR OPTIONAL FACTORY INSTALLED DIFFERENTIAL PRESSURE FLOW SWITCH WHEN EQUIPPED

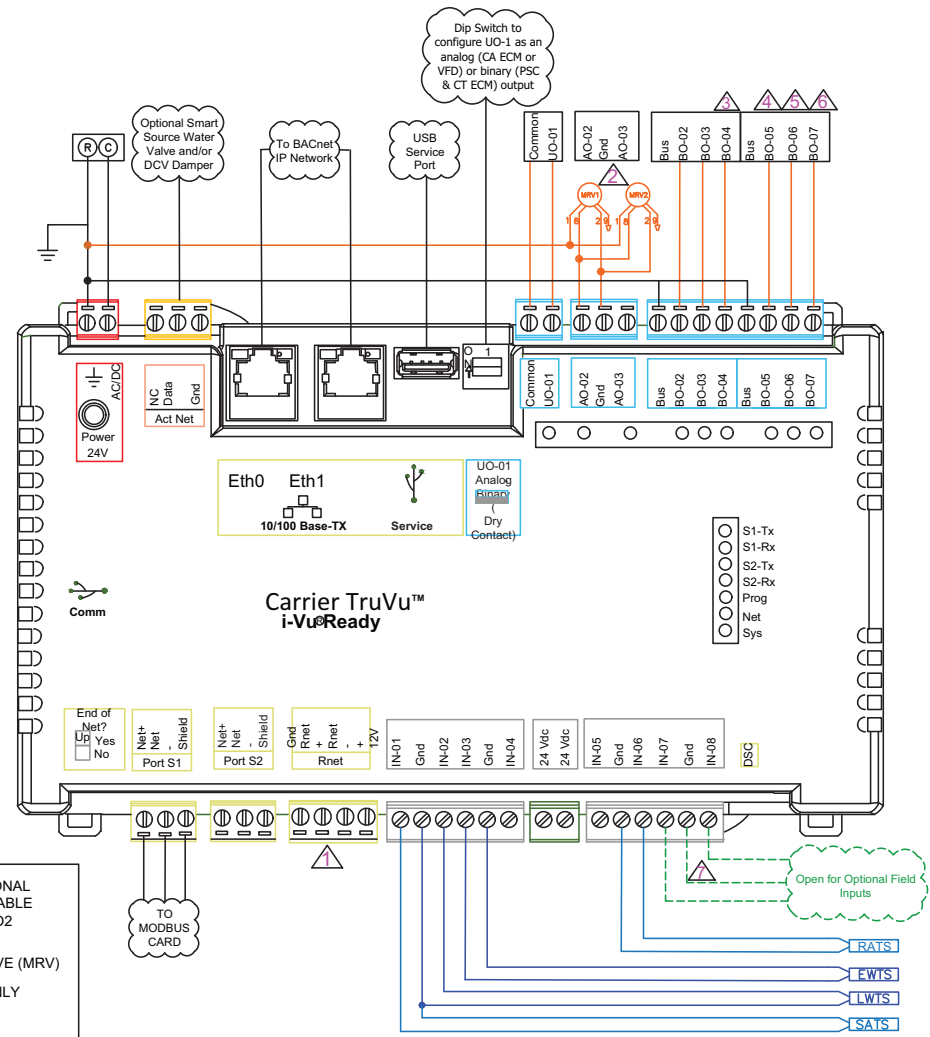

8 733 837 662 REV 1

Fig. 13 — TruVu™ DDC Wiring Diagram

Step 5 — Install Supply and Return Piping

The following items should be adhered to in addition to applicable piping codes.

- A drain valve at the base of each riser to enable proper flushing of the system at startup and during servicing.
- Shutoff/isolation ball valves at the supply and return connections and unions at each unit to permit proper flow balancing and unit servicing.
- Strainers at the inlet of each circulating pump. Use Teflon^{®1} tape on threaded pipe fittings to eliminate water leaks and ensure against air entering the system.
- Flexible hose connections between the unit and the rigid system to eliminate the possibility of vibration transmission through the piping.
- Insulation is not normally required on supply and return piping for boiler tower installations except in unheated sections or outdoor runs.
- Insulation is required for closed-loop Geothermal installations as loop temperatures may fall below the dew point and can even fall below the freezing point of water during heating season.

Hose Kits

When using optional hose kits follow the manufacturer's recommendations for installation. Never stretch or twist hoses and never use hoses that show external wear or damage or are suspected of having damage. Never exceed the manufacturer's maximum working pressure recommendations.

Step 6 — Install Condensate Piping

Console units are designed with a blow-through configuration in the air-handling section. This means that there is positive pressure at the unit drain pan and thus trapping is not required. Condensate is routed from the drain pan via a 5/8 in. non-pressure rated vinyl hose that is located below the supply and return water connections.

Though horizontal runs of condensate piping are usually too short to pose problems, horizontal runs should be pitched at least 1 in. for every 10 ft of piping. Avoid low spots or no sloped piping, as these areas can collect sediment and eventually block condensate flow. Always inspect both internal and external condensate piping for kinks that could block condensate flow.

PRE-START-UP

System Cleaning and Flushing

Cleaning and flushing the unit and system is the single most important step to ensure proper start-up and continued efficient operation of the system. See Table 3.

⚠ WARNING

To prevent injury or death due to electrical shock or contact with moving parts, open unit disconnect before servicing unit.

⚠ CAUTION

TO AVOID POSSIBLE DAMAGE DO NOT FLUSH SYSTEM THROUGH THE UNIT!

Follow the instructions below to properly clean and flush the system:

1. Verify that electrical power to the units is disconnected, and that the circulation pump is deenergized.
2. Connect the supply hose directly to the return riser valve. Use a single length of flexible hose.

NOTE: If the length of hose is too short (i.e., the resulting connection would exceed the minimum bend radius of the hose), substitute two lengths of flexible hose joined together with a field-supplied, standard NPT coupling and the flare-fitting-to-pipe adapters provided with the hose kit.

3. Open all air vents. Fill the system with water. Do not allow system to overflow. Bleed all air from the system. Check the system for leaks and repair appropriately.
4. Check and adjust the water and air level in the expansion tank.
5. Verify all strainers are in place. Start the pumps, and systematically check each vent to ensure all air is bled from the system.
6. Verify make-up water is available. Adjust make-up water appropriately to replace the air that was bled from the system. Pressure test and inspect the system for leaks and make any necessary repairs. Check and adjust the water and air level in the expansion tank.
7. Open a drain at the lowest point in the system. Adjust the make-up water replacement rate to equal the rate of bleed. Continue to bleed the system until the water appears clean or for at least three hours, whichever is longest; then, completely drain the system.
8. Refill the system with clean, chemically treated water. Since water varies for each locality, contact a local water treatment company for the correct treatment chemicals to use in the area. See Table 4 for water quality guidelines. Set the boiler to raise the loop temperature to approximately 85°F.

⚠ CAUTION

To avoid possible damage to piping systems constructed of plastic piping DO NOT allow loop temperature to exceed 110°F.

Circulate the solution for a minimum of 8 to 24 hours. At the end of this period, shut off the circulating pump and drain the solution. Repeat system cleaning as necessary.

9. When the cleaning process is complete, remove the short-circuited hoses. Connect the hoses to the proper supply and return connections on each unit. Refill the system and bleed off all air.
10. Test the system pH with litmus paper. The system water should be slightly alkaline (pH 7.0 to 8.5). Add chemicals, as appropriate, to maintain acidity levels.

⚠ CAUTION

DO NOT use "Stop-Leak" or any similar chemical agent in this system. Addition of these chemicals to the loop water will foul the system and will inhibit unit operation.

11. When the system is successfully cleaned, flushed, refilled and bled, check the main system panels, safety cutouts and alarms. Set the controls to properly maintain loop temperatures.

1. Third-party trademarks and logos are the property of their respective owners.

Table 3 – 50PEC Series WSHP Operating Limits

FLUID TYPE	LIMIT	COOLING	HEATING	
Air	Minimum Ambient (°F)	50	40	
	Maximum Ambient (°F)	100	85	
	Rated Ambient (°F)	80	68	
	Minimum Entering (°F db / wb)	65/57	45	
	Maximum Entering (°F db / wb)	95/85	80	
	Rated Entering (°F)	80/67	68/57	
Liquid	Minimum Entering (°F)	50	20	
	Max Entering (°F)	110	80	
	Rated Entering (°F)	Water Loop	86	68
		Ground Loop	77	32
		Ground Water	59	50
	Anti-Freeze Requirement (LWT / EWT °F)	<40 / <50		
	Maximum Operating Water Pressure (psi / kPa)	450 psi / 3100 kPa		
Minimum Operating Flow Rate (gpm / ton)	1.5			

LEGEND

- db** — Dry Bulb
- EWT** — Entering Water Temperature
- LWT** — Leaving Water Temperature
- wb** — Wet Bulb

System Checkout

After completing the installation, and before energizing the unit, the following system checks should be made:

- Verify that the supply voltage to the heat pump is in accordance with the nameplate ratings.
- Verify the control transformer is tapped for the correct voltage.
- Make sure that all electrical connections are tight and secure.
- Check the electrical fusing and wiring for the correct size.
- Verify that the water piping is complete and correct.
- Check that the water flow is correct, and adjust if necessary.
- Check for water leaks and correct as necessary.
- Check the blower for free rotation, and that it is secured to the shaft.
- Verify that the return air filter has been installed and is clean.
- Verify that vibration isolation has been provided.
- Be certain that all access panels are secured in place.

⚠ CAUTION

Ensure cabinet and electrical box are properly grounded. Failure to follow these procedures may result in damage to equipment.

- Verify that the low voltage wiring between the thermostat and the unit is correct.

⚠ CAUTION

To avoid equipment damage, DO NOT leave system filled in a building without heat during the winter unless antifreeze is added to system water. Condenser coils never fully drain by themselves and will freeze unless winterized with antifreeze.

Table 4 – Water Quality Guidelines^{a,b}

CONDITION	HX MATERIAL ^c	CLOSED RECIRCULATING ^d	OPEN LOOP AND RECIRCULATING WELL ^e		
Scaling Potential — Primary Measurement					
Above the given limits, scaling is likely to occur. Scaling indexes should be calculated using the limits below.					
pH/Calcium Hardness Method	All	N/A	pH < 7.5 and Ca Hardness, <100 ppm		
Index Limits for Probable Scaling Situations (Operation outside these limits is not recommended.)					
Scaling indexes should be calculated at 150 F for direct use and HWG applications, and at 90 F for indirect HX use. A monitoring plan should be implemented.					
Ryznar Stability Index	All	N/A	6.0 - 7.5 If >7.5 minimize steel pipe use.		
Langelier Saturation Index	All	N/A	-0.5 to +0.5 If <-0.5 minimize steel pipe use. Based upon 150 F HWG and direct well, 85 F indirect well HX.		
Iron Fouling					
Iron Fe ²⁺ (Ferrous) (Bacterial Iron Potential)	All	N/A	<0.2 ppm (Ferrous) If Fe ²⁺ (ferrous) >0.2 ppm with pH 6 - 8, O ₂ <5 ppm check for iron bacteria.		
Iron Fouling	All	N/A	<0.5 ppm of Oxygen Above this level deposition will occur.		
Corrosion Prevention^f					
pH	All	6 - 8.5 Monitor/treat as needed.	6 - 8.5 Minimize steel pipe below 7 and no open tanks with pH <8.		
Hydrogen Sulfide (H ₂ S)	All	N/A	<0.5 ppm At H ₂ S>0.2 ppm, avoid use of copper and cupronickel piping or HXs. Rotten egg smell appears at 0.5 ppm level. Copper alloy (bronze or brass) cast components are okay to <0.5 ppm.		
Ammonia Ion as Hydroxide, Chloride, Nitrate and Sulfate Compounds	All	N/A	<0.5 ppm		
Maximum Chloride Levels	Copper Cupronickel 304 SS 316 SS Titanium	N/A N/A N/A N/A N/A	Maximum allowable at maximum water temperature.		
			50°F (10°C)	75°F (24°C)	100°F (38°C)
			<20 ppm	NR	NR
			<150 ppm	NR	NR
			<400 ppm	<250 ppm	<150 ppm
<1000 ppm	<550 ppm	<375 ppm			
>1000 ppm	>550 ppm	>375 ppm			
Erosion and Clogging					
Particulate Size and Erosion	All	<10 ppm of particles and a maximum velocity of 6 fps. Filtered for maximum 800 micron size.	<10 ppm (<1 ppm "sandfree" for reinjection) of particles and a maximum velocity of 6 fps. Filtered for maximum 800 micron size. Any particulate that is not removed can potentially clog components.		
Brackish	All	N/A	Use cupronickel heat exchanger when concentrations of calcium or sodium chloride are greater than 125 ppm are present. (Seawater is approximately 25,000 ppm.)		

NOTE(S):

- Sulfides in the water quickly oxidize when exposed to air, requiring that no agitation occur as the sample is taken. Unless tested immediately at the site, the sample will require stabilization with a few drops of one Molar zinc acetate solution, allowing accurate sulfide determination up to 24 hours after sampling. A low pH and high alkalinity cause system problems, even when both values are within ranges shown. The term pH refers to the acidity, basicity, or neutrality of the water supply. Below 7.0, the water is considered to be acidic. Above 7.0, water is considered to be basic. Neutral water contains a pH of 7.0.
- To convert ppm to grains per gallon, divide by 17. Hardness in mg/l is equivalent to ppm.
- Heat exchanger materials considered are copper, cupronickel, 304 SS (stainless steel), 316 SS, titanium.
- Closed recirculating system is identified by a closed pressurized piping system.
- Recirculating open wells should observe the open recirculating design considerations.
- If the concentration of these corrosives exceeds the maximum allowable level, then the potential for serious corrosion problems exists.

LEGEND

- HWG** — Hot Water Generator
HX — Heat Exchanger
N/A — Design Limits Not Applicable Considering Recirculating Potable Water
NR — Application Not Recommended
SS — Stainless Steel

START-UP

NOTE: You must use the Start-Up Checklist provided on pages CL-1 and CL-2 of this document when performing unit start-up for the first time. See Table 5 and Fig. 14 for operating data.

1. Use the fan speed selector switch to set the fan to the desired speed (hi or lo).
2. Set the thermostat to the highest setting.
3. Set the thermostat system switch to “COOL” and the fan switch to the “AUTO” position. The reversing valve solenoid should energize. The compressor and fan should not run.
4. Reduce the thermostat setting approximately 5 degrees below the room temperature.
5. Verify the heat pump is operating in the cooling mode.
6. Turn the thermostat system switch to the “OFF” position. The unit should stop running and the reversing valve should de-energize.
7. Leave the unit off for approximately 5 minutes to allow for system equalization.
8. Turn the thermostat to the lowest setting.
9. Set the thermostat switch to “HEAT”.
10. Increase the thermostat setting approximately 5 degrees above the room temperature.
11. Verify the heat pump is operating in the heating mode.
12. Set the thermostat to maintain the desired space temperature.
13. Check for vibrations, leaks, etc.

Antifreeze

In areas where entering loop temperatures drop below 50°F or where piping will be routed through areas subject to freezing, antifreeze is needed.

Alcohols and glycols are commonly used as antifreeze agents. Freeze protection should be maintained to 15°F below the lowest

expected entering loop temperature. For example, if the lowest expected entering loop temperature is 30°F, the leaving loop temperature would be 22 to 25°F. Therefore, the freeze protection should be at 15°F (30°F – 15°F) = 15°F.

IMPORTANT: All alcohols should be pre-mixed and pumped from a reservoir outside of the building or introduced under water level to prevent alcohols from fuming.

Calculate the total volume of fluid in the piping system. See Table 6. Use the percentage by volume in Table 7 to determine the amount of antifreeze to use. Antifreeze concentration should be checked from a well mixed sample using a hydrometer to measure specific gravity.

FREEZE PROTECTION SELECTION

The 25°F FP1 factory setting (water) should be used to avoid freeze damage to the unit. Once antifreeze is selected, refer to the See Fig. 15 — on page 24 for FREEZE Protection settings on the UPM board.

Cooling Tower/Boiler Systems

These systems typically use a common loop maintained at 60 to 90°F. Carrier recommends using a closed circuit evaporative cooling tower with a secondary heat exchanger between the tower and the water loop. If an open type cooling tower is used continuously, chemical treatment and filtering will be necessary.

Ground Coupled, Closed Loop and Plateframe Heat Exchanger Well Systems

These systems allow water temperatures from 30 to 110°F. The external loop field is divided up into 2 in. polyethylene supply and return lines. Each line has valves connected in such a way that upon system start-up, each line can be isolated for flushing using only the system pumps. Air separation should be located in the piping system prior to the fluid re-entering the loop field.

Table 5 – Operating Temperatures and Pressures

50PEC UNIT SIZE	ENTER FLUID TEMP (°F)	WATER FLOW (GPM)	COOLING				HEATING				
			Suction Pressure (psig)	Discharge Pressure (psig)	Water Temp Rise °F	Air Temp Drop °F	Suction Pressure (psig)	Discharge Pressure (psig)	Water Temp Drop °F	Air Temp Rise °F	
009	30	1.25	—	—	—	—	82-92	261-281	6-7	14-18	
		2.50	—	—	—	—	86-96	265-285	3-4	15-19	
	40	1.25	130-147	189-207	16-19	18-22	96-106	274-294	8-9	17-21	
		2.50	129-146	171-189	8-11	18-22	102-112	279-299	4-5	18-22	
	50	1.25	132-149	217-235	16-19	18-22	110-120	288-308	9-10	20-24	
		2.50	132-149	199-217	7-10	18-22	118-128	296-316	5-6	21-25	
	60	1.25	133-150	248-266	15-18	17-21	125-135	303-323	11-12	22-26	
		2.50	134-151	231-249	7-10	18-22	135-145	313-333	6-7	24-28	
	70	1.25	136-153	283-301	14-17	17-21	141-151	319-339	12-13	25-29	
		2.50	135-152	265-283	7-10	17-21	154-164	333-353	7-8	28-32	
	80	1.25	141-158	323-341	14-17	18-22	158-168	338-358	14-15	28-32	
		2.50	140-157	305-323	7-10	18-22	174-184	356-376	8-9	31-35	
	90	1.25	144-161	364-382	13-16	18-22	177-187	359-379	16-17	32-36	
		2.50	143-160	348-366	6-9	18-22	198-208	383-403	9-10	36-40	
	100	1.25	146-163	410-428	12-15	17-21	—	—	—	—	
		2.50	145-162	396-414	6-9	17-21	—	—	—	—	
	012	30	1.50	—	—	—	—	81-91	275-295	7-8	13-17
			3.00	—	—	—	—	86-96	278-298	3-4	14-18
40		1.50	133-149	180-204	18-21	17-21	95-105	287-307	8-9	16-20	
		3.00	132-148	160-184	9-12	18-22	102-112	295-315	4-5	17-21	
50		1.50	135-151	206-230	18-21	17-21	110-120	304-324	10-11	18-22	
		3.00	134-150	184-208	9-12	18-22	118-128	313-333	5-6	19-23	
60		1.50	137-153	235-259	17-20	17-21	126-136	322-342	12-13	21-25	
		3.00	136-152	213-237	8-11	17-21	134-144	331-351	6-7	22-26	
70		1.50	139-155	267-291	17-20	17-21	139-149	336-356	14-15	23-27	
		3.00	138-154	247-271	8-11	17-21	152-162	352-372	7-8	25-29	
80		1.50	140-156	302-326	16-19	16-20	155-165	355-375	15-16	25-29	
		3.00	138-154	284-308	8-11	16-20	173-183	376-396	8-9	28-32	
90		1.50	141-157	339-363	15-18	16-20	174-184	377-397	17-18	28-32	
		3.00	141-157	325-349	7-10	16-20	196-206	404-424	10-11	32-36	
100		1.50	141-157	351-375	15-18	16-20	—	—	—	—	
		3.00	141-157	335-359	7-10	16-20	—	—	—	—	
015		30	2.00	—	—	—	—	76-96	264-284	6-7	17-21
			4.00	—	—	—	—	81-101	267-287	3-4	18-22
	40	2.00	126-142	178-198	16-19	20-24	89-109	276-296	8-9	20-24	
		4.00	126-142	161-181	8-11	20-24	95-115	282-302	4-5	21-25	
	50	2.00	129-145	205-225	16-19	20-24	104-124	291-311	9-10	23-27	
		4.00	127-143	184-204	8-11	20-24	110-130	298-318	5-6	24-28	
	60	2.00	131-147	234-254	15-18	20-24	116-136	305-325	11-12	25-29	
		4.00	130-146	214-234	7-10	20-24	127-147	316-336	6-7	27-31	
	70	2.00	134-150	267-287	15-18	20-24	132-152	322-342	12-13	28-32	
		4.00	132-148	247-267	7-10	20-24	145-165	336-356	7-8	31-35	
	80	2.00	137-153	302-322	14-17	20-24	150-170	342-362	14-15	32-36	
		4.00	136-152	284-304	7-10	20-24	166-186	360-380	8-9	35-39	
	90	2.00	139-155	341-361	14-17	20-24	169-189	363-383	16-17	36-40	
		4.00	137-153	326-346	6-9	19-23	190-210	387-407	9-10	40-44	
	100	2.00	140-156	383-403	13-16	19-23	—	—	—	—	
		4.00	140-156	372-392	6-9	19-23	—	—	—	—	

Table 5 – Operating Temperatures and Pressures (cont)

50PEC UNIT SIZE	ENTER FLUID TEMP (°F)	WATER FLOW (GPM)	COOLING				HEATING			
			Suction Pressure (psig)	Discharge Pressure (psig)	Water Temp Rise °F	Air Temp Drop °F	Suction Pressure (psig)	Discharge Pressure (psig)	Water Temp Drop °F	Air Temp Rise °F
018	30	2.25	—	—	—	—	71-87	267-324	8-10	23-27
		4.50	—	—	—	—	76-92	273-331	4-5	24-29
	40	2.25	106-131	186-225	17-23	23-27	81-99	279-341	9-10	26-30
		4.50	105-129	159-195	9-12	23-27	87-106	287-350	5-6	28-33
	50	2.25	107-133	200-246	17-23	22-26	92-113	293-359	11-12	29-34
		4.50	106-131	183-226	8-11	22-27	100-122	303-371	6-7	31-37
	60	2.25	108-135	227-280	16-22	21-26	105-128	308-379	12-14	32-38
		4.50	108-133	211-261	8-12	22-26	115-140	322-395	7-8	35-41
	70	2.25	110-137	256-317	16-22	21-25	118-145	325-401	14-16	36-42
		4.50	110-136	242-299	7-12	22-26	132-160	342-420	7-8	39-46
	80	2.25	112-140	290-358	15-21	21-25	134-163	344-424	15-18	39-46
		4.50	112-138	278-341	8-11	21-25	151-182	365-448	8-10	43-50
	90	2.25	114-142	326-402	14-20	21-25	152-184	364-450	16-19	43-51
		4.50	114-141	318-388	7-10	21-25	173-207	390-477	9-11	47-55
	100	2.25	116-145	368-451	14-19	20-24	—	—	—	—
		4.50	117-144	362-439	7-10	20-24	—	—	—	—

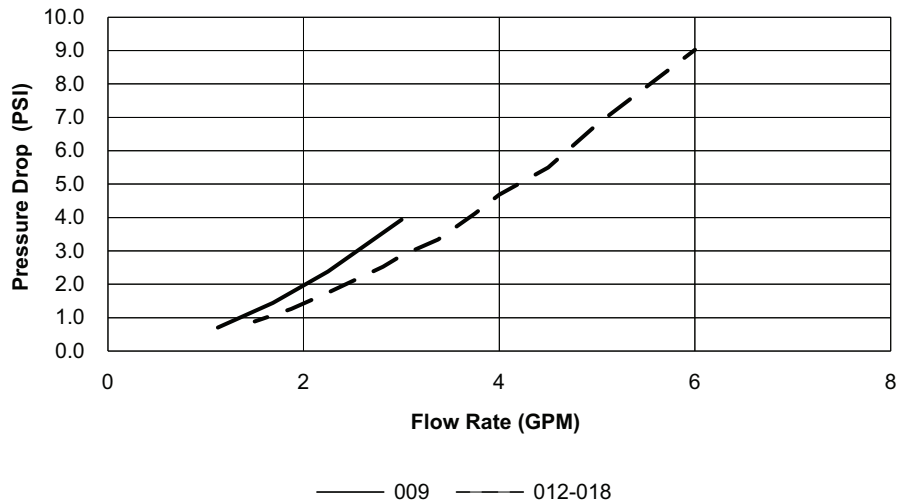

Fig. 14 – Water Pressure Drop Curve

OPERATION

Table 6 — Approximate Fluid Volume (gal.) per 100 ft of Pipe^a

PIPE	DIAMETER (in.)	VOLUME (gal.)
Copper	1.00	4.1
	1.25	6.4
	1.50	9.2
Rubber Hose	1.00	3.9
Polyethylene	3/4 IPS SDR11	2.8
	1 IPS SDR11	4.5
	1-1/4 IPS SDR11	8.0
	1/2 IPS SDR11	10.9
	2 IPS SDR11	18.0
	1-1/4 IPS SCH40	8.3
	1-1/2 IPS SCH40	10.9
	2 IPS SCH40	17.0

NOTE(S):

a. Volume of heat exchanger is approximately 1.0 gallon.

LEGEND

IPS — Internal Pipe Size
SCH — Schedule
SDR — Standard Dimensional Ratio

Table 7 — Antifreeze Percentages by Volume

ANTIFREEZE	MINIMUM TEMPERATURE FOR FREEZE PROTECTION (F)			
	10	15	20	25
Methanol (%)	25	21	16	10
100% USP Food Grade Propylene Glycol (%)	38	30	22	15

Sequence of Operation of Units Without DDC Controller

COOLING MODE

Energizing the “O” terminal energizes the unit reversing valve in the cooling mode. The fan motor starts when the “G” terminal is energized.

NOTE: The fan motor will take 30 seconds to ramp up to operating speed and will run at fan only rated air flow as long as there is no call for compressor or heater operation.

When the thermostat calls for cooling (Y+O) the loop pump or solenoid valve if present is energized and the capacity starts. The fan ramps up to cooling air flow.

Once the thermostat is satisfied, the compressor shuts down accordingly and the fan ramps down to either fan only mode or off over a span of 30 seconds.

NOTE: A fault condition initiating a lockout will de-energize the compressor irrespective of which stage is engaged.

HEATING MODE

The heating (Y) operates in the same manner as cooling, but with the reversing valve de-energized. Once the thermostat is satisfied, the compressor shuts down and the fan ramps down either fan only mode or off.

Unit Protection Module (UPM)

UNIT PROTECTION MODULE (UPM)

The Unit Protection Module (UPM) as shown in Fig. 15 is a printed circuit board (PCB) included in all units, that interfaces with the thermostat or the digital direct controller. The main purpose of this device is to protect the compressors by monitoring the different states of switches and sensors of each refrigerant circuit. This device provides time delays and protects the unit against freezing of the water and refrigerant heat exchangers as well as condensate overflow when the appropriate sensors are installed. Figure 16 shows the UPM sequence of operations for unit safeties.

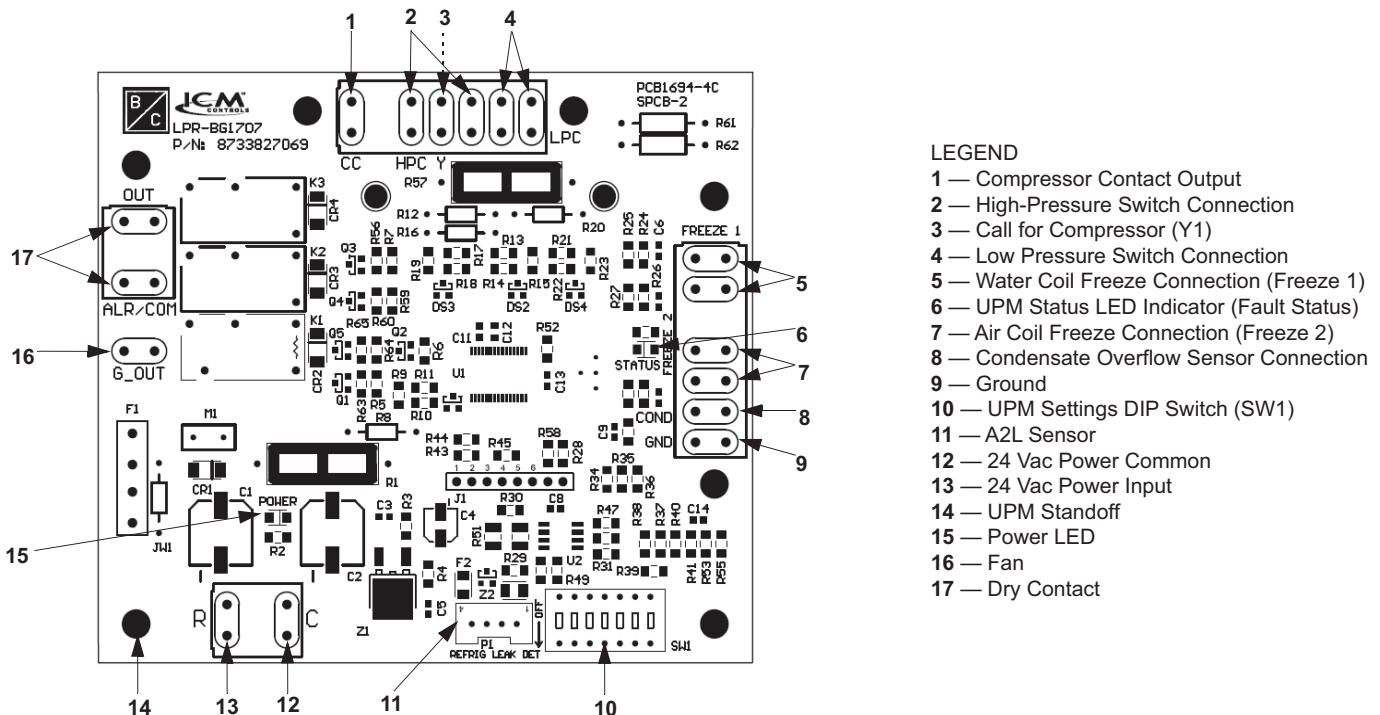

Fig. 15 — Unit Protection Module (UPM)

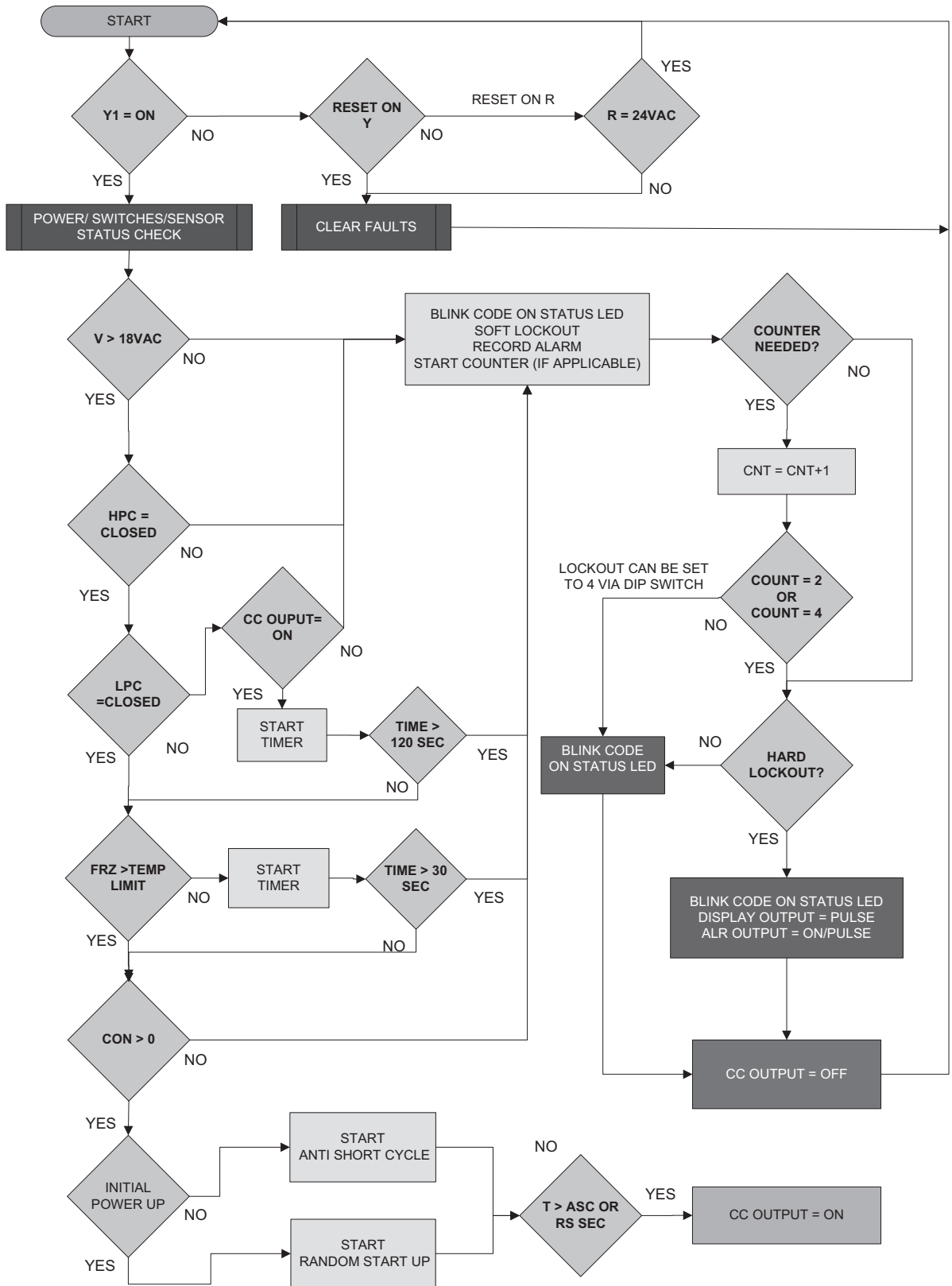

Fig. 16 – Sequence of Operations

UPM Standard Safeties and Alarms

HI AND LOW REFRIGERANT PRESSURE PROTECTION

- High-pressure switch located in the refrigerant discharge line and wired across the HPC (High-Pressure Switch Connection) terminals on the UPM.
- Low-pressure switch located in the unit refrigerant suction line and wired across the LPC (Low-Pressure Switch Connection) terminals (LPC1 and LPC2) on the UPM.

WATER COIL FREEZE PROTECTION

Waterside freeze protection sensor, mounted close to condensing water coil, monitors refrigerant temperature between condensing water coil and thermal expansion valve. See Fig. 17.

If temperature drops below or remains at freeze limit trip for 120 seconds, the controller will shut down the compressor and enter into a soft-lockout condition. The default freeze limit trip is 25°F; however, this can be changed to 15°F by flipping DIP switch SW1. (See Fig. 15, Item 10, Fig. 17, and Table 8.)

NOTE: The UPM Board Dry Contacts are Normally Open (NO).

IMPORTANT: The freeze sensor will not guard against the loss of water. A flow switch is recommended to prevent the unit from running if water flow is lost or reduced.

IMPORTANT: If the unit is employing a fresh water system (no anti-freeze protection), it is extremely important to have the Freeze 1 set to 25°F (DIP Switch SW1 set to Off) in order to shut down the unit at the appropriate leaving water temperature and protect your heat pump from freezing if a freeze sensor is included.

AIR COIL FREEZE PROTECTION

Air coil freeze protection sensor, mounted between the thermal expansion device and the evaporator, monitors refrigerant temperature between the evaporator coil and thermal expansion valve (see Fig. 19). If temperature drops below or remains at the freeze limit trip for 30 seconds, the controller will shut down the compressor and enter into a soft-lockout condition. The default freeze limit trip is 25°F, this can be changed to 15°F by flipping DIP switch SW1. (See Fig. 15, Item 10, Fig. 18, and Table 8.)

Table 8 – UPM DIP Switch Selectable Positions

TOGGLE	FUNCTION	ON	OFF	FACTORY DEFAULT
1	Lockout	4	2	2
2	Reset	R	Y	Y
3	Alarm	Cont	Pulse	Pulse
4	Test	Yes	No	No
5	Freeze 1	15°F	25°F	25°F
6	Freeze 2	15°F	25°F	25°F
7	Pump	ON	OFF	OFF

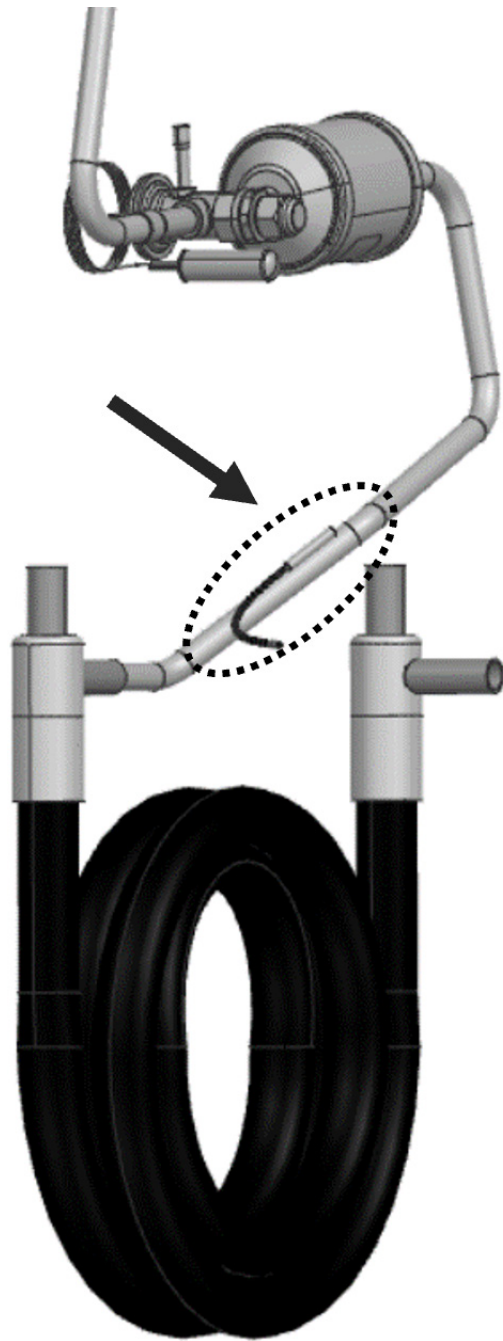

Fig. 17 – Waterside Freeze Sensor Location (FREEZE – Vertical Configuration Show)

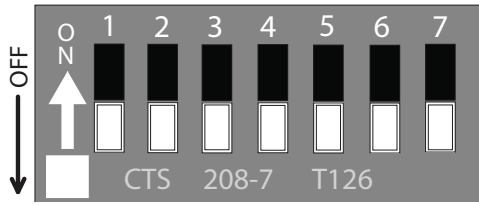

Fig. 18 — UPM Settings DIP Switch (SW1)

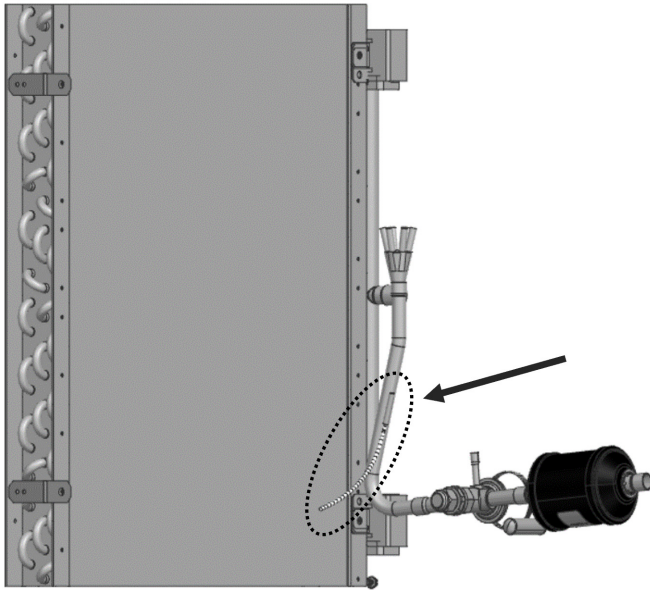

Fig. 19 — Air Coil Freeze Sensor Location (FREEZE 2) — Vertical Configuration Shown

HIGH CONDENSATE LEVEL SHUTDOWN

The condensate overflow protection sensor is located in the drain pan of the unit and connected to the “COND” terminal on the UPM board. See Fig. 15, Item 8.

Anti-Short Cycle Timer

Five minute delay on break timer to prevent compressor short cycling.

Random Start Time Delay

Each controller has an unique random start delay ranging from 270 to 300 seconds on initial power up to reduce the chance of multiple units simultaneously starting at the same time after power up or after a power interruption, in order to avoid creating a large electrical spike.

Low-Pressure Bypass Timer

If the compressor is running and the low pressure switch opens, the controller will keep the compressor On for 120 seconds. After two minutes if the low-pressure switch remains open, the controllers will shut down the compressor and enter a soft lockout. The compressor will not be energized until the low-pressure switch closes and the anti-short cycle time delay expires. If the low-pressure switch opens two or four times in one hour, the unit will enter a hard lockout. In order to exit hard lockout power to the unit would need to be reset. The reset signal is either a Y or R signal depending on the position of the DIP switch as shown in Table 8. If the reset is set to R, the board must be manually powered off and powered back on to exit the hard lock out.

Brownout/Surge/Power Interruption Protection

The brownout protection in the UPM board will shut down the compressor if the incoming power falls below 18 vac. The compressor will remain Off until the voltage is above 18 vac and Anti-Short Cycle Timer (300 seconds) times out. The unit will not go into a hard lockout.

Alarm Output

Alarm output is Normally Open (NO) dry contact. If pulse is selected the alarm output will be pulsed. The fault output will depend on the DIP switch setting for “Alarm”. If it is set to “CONST”, a constant signal will be produced to indicate a fault has occurred and the unit requires inspection to determine the type of fault. If it is set to “PULSE” a pulse signal is produced and a fault code is detected by a remote device indicating the fault. (For blink code explanation, see Table 9). The remote device must have a analog input with malfunction detection capability to interpret PULSE signal when the UPM board is set to “PULSE”.

IMPORTANT: If 24 VAC output is needed R must be wired to ALR-COM terminal; 24 VAC will be available to the ALR-OUT terminal when the unit is in the alarm condition.

Test Mode

A test DIP switch is provided to reduce all time delays settings to 10 seconds during troubleshooting or verification of unit operation.

IMPORTANT: Operation of unit in test mode can lead to accelerated wear and premature failure of components. The “TEST” switch must be set back to “NO” after troubleshooting/servicing.

INTELLIGENT ALARM RESET

If a fault condition is initiated, the five minute delay on break time period is initiated and the unit will restart after these delays expire. During this period the fault LED will indicate the cause of the fault. If the fault condition still exists or occurs two or four times (depending on “2” or “4” settings for Lockout DIP Switch) before 60 minutes, the unit will go into a hard lockout and requires a manual lockout reset. See Fig. 18.

HARD LOCKOUT RESET

A hard lockout can be reset by turning the unit thermostat off and then back on when the “RESET” DIP switch is set to “Y” or by shutting off unit power at the circuit breaker when the “RESET” DIP switch is set to “R”.

NOTE: The blower motor will remain active during a lockout condition.

Table 9 — UPM Fault Blink Codes

BLINKS	FAULT	FAULT CRITERIA
None	None	All fault conditions normal.
1	High Pressure	Refrigerant discharge pressure has exceeded 600 psig.
2	Low Pressure	Refrigerant suction pressure has fallen below 40 psig.
3	Water Coil Freeze Condition	Refrigerant temperature to the water coil has fallen below 25°F for 120 seconds.
4	Condensate Overflow	Condensate levels in the unit drain pan are too high.
5	Brown Out	Control voltage has fallen below 18 VAC
6	Air Coil Freeze Condition	Refrigerant temperature to the air coil has fallen below 25°F for 120 seconds.

Units with Options

UPM board can be ordered with additional following options:

ENERGY MANAGEMENT SWITCH

Enables 24 vac external signal to control the operation of the WSHP.

PUMP/VALVE RELAY

Provides a signal between an isolation valve and a secondary pump.

Sequence of Operation for Units with TruVu DDC Controller

Units with TruVu™ DDC controller still feature a UPM board for unit operation, so the operation will be similar to the sequence for units without DDC controller. TruVu™ controller does feature advanced functionality, such as automatic fan speed control and intelligent alarming, which will differ from the units with UPM board only. Below is an overview of the different features for the TruVu™ controls. See Fig. 20 for TruVu™ Control Board overview.

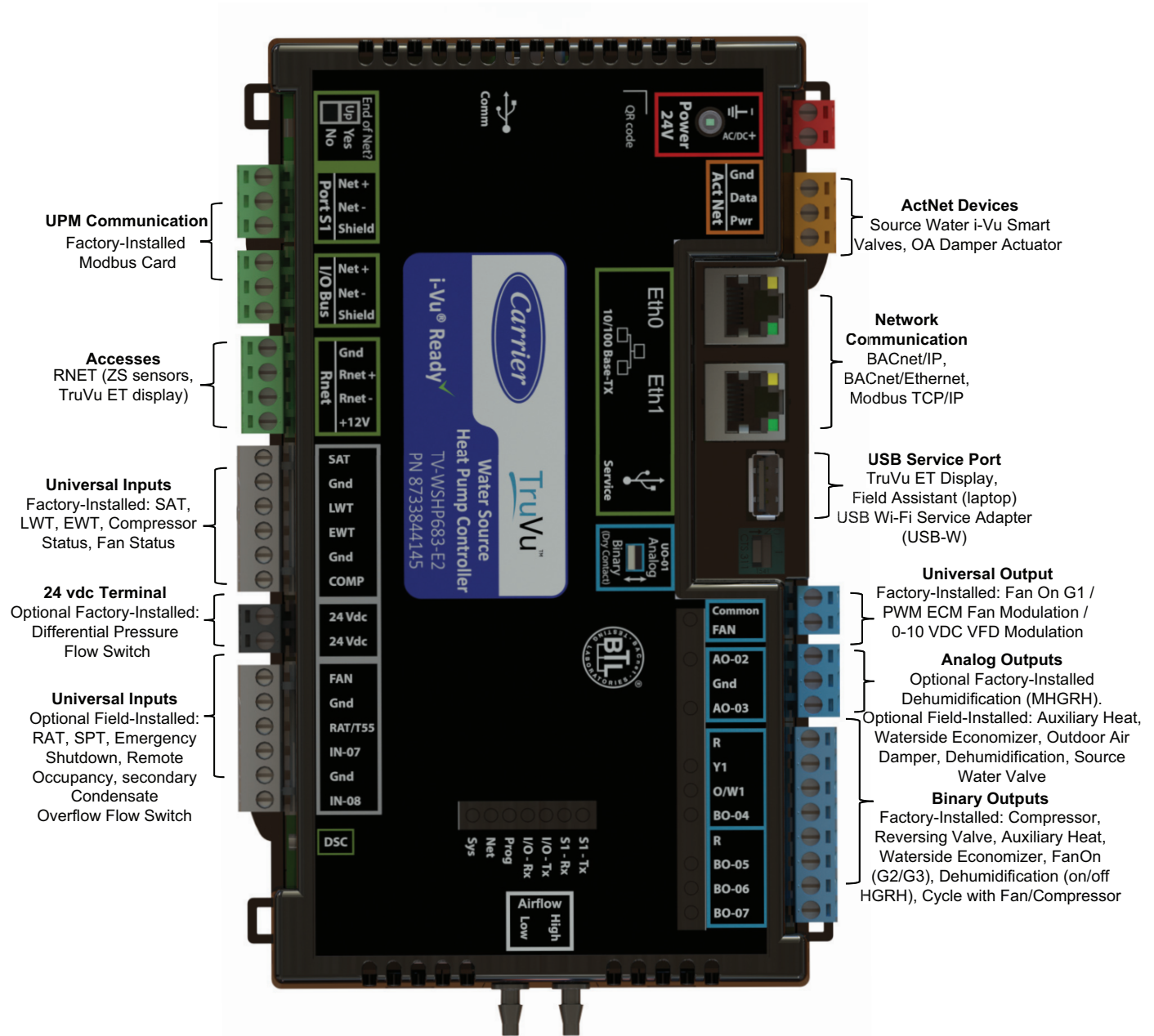

Fig. 20 – TruVu™ Control Board

SCHEDULING

Time periods can be configured to schedule the transitions from occupied to unoccupied operation. The time periods control the space temperature to occupied heating and cooling setpoints. The unit operates continuously in the Occupied mode until a time schedule is configured by using either the TruVu™ Equipment Touch, Field Assistant, the i-Vu® application, or a third-party control system enables/disables the BAS On/Off point. The local time and date for these functions must be set to operate properly.

The occupancy source can be changed to one of the following:

Occupancy Schedules

The controller is occupied 24/7 until you configure a time schedule using either the TruVu Equipment Touch, Field Assistant, the i-Vu® application, or a third party Enables/Disables the BAS On/Off point. You can disable this by going to Configuration > Unit Configuration > Occupancy Schedules, changing the point from Enable to Disable and clicking OK.

NOTE: You must Enable this point in order for the TruVu ET Touch, Field Assistant, or the i-Vu® application to assign a time schedule to the controller.

Schedule Schedule

The unit operates according to the schedule configured and stored in the unit. The schedule is accessible via the TruVu ET, the i-Vu® application, or Field Assistant. The daily schedule consists of a start and stop time (standard or 24-hour mode) and 7 days of the week, starting with Monday and ending on Sunday.

CAUTION

Scheduling can only be controlled from one source.

Occupancy Input Contact (Option)

If configured for remote occupancy control (default), the TruVu™ controller can use an external dry contact closure to determine the occupancy status of the unit. You must disable the Occupancy Schedules in order to use the occupancy contact input. The unit enters an occupied mode when it senses the abnormal input. After the input returns to its normal state, the unit stays in the occupied mode for the configured Occ Override Delay period (15 minutes default).

BAS (Building Automation System) On/Off

For use with a Building Automation System that supports network scheduling, you must disable the Occupancy Schedules so the BAS system can control the unit through a network communication and the BAS scheduling function.

Global Occupancy Scheduling

The TruVu™ controller can read the occupancy status from another unit so that a group of WSHPs can be controlled from a single occupancy schedule. The local Occupancy Schedules must be disabled in order to use the global occupancy input.

BACnet® Network Occupancy Input

The TruVu™ controller can accept an external BACnet®¹ Binary Network Input for occupancy control. This function is only compatible with units used in BACnet® systems. You need to configure the System Occupancy BACnet® network input point to locate the device and point name where the external occupancy point information resides. You must also disable Occupancy Schedules in order to use this input.

INDOOR FAN

Fan Modes

You can configure the indoor fan to operate in any one of 3 fan modes:

- Auto - intermittent operation during both occupied and unoccupied periods
- Continuous (default) - intermittent operation during unoccupied periods and continuous during occupied periods
- Always On - operates the fan continuously during both occupied and unoccupied periods

In the continuous default mode, the fan is turned on when any one of the following is true:

- It is in occupied mode, which is determined by the occupancy status.
- There is a demand for cooling or heating in unoccupied mode.
- There is a call for dehumidification (optional).

Fan Delay

When power is reapplied after a power outage, there is a configurable delay of 5 - 600 seconds (default 60) before starting the fan. You must configure the fan delay:

- The Fan On Delay defines the delay time (0 - 30 seconds, default 10) before the fan begins to operate after heating or cooling is started.
- The Fan Off Delay defines the delay time (0 - 180 seconds, default 45) the fan continues to operate after heating or cooling is stopped.

NOTE: The fan continues to run as long as the compressors, heating stages, or the dehumidification relays are on. If the SPT failure alarm, ZS Sensor failure alarm, or condensate overflow alarm is active, the fan is shutdown immediately, regardless of occupancy state or demand.

Fan Status

You can configure an optional input as either an occupancy input contact or a fan status input. If configured as fan status, the controller compares the status of the fan to the desired commanded state. When the fan is commanded to run (ON), the fan status is checked and verified to match the commanded state. If the fan status is not on, then a fan status alarm is generated after 1 minute and the equipment's compressor(s) and auxiliary heat is disabled and the optional OA damper closes.

COOLING OPERATION

Space Temperature Control

The TruVu™ controller operates 1 or 2 stages of compression to maintain the desired cooling setpoint. The compressor outputs are controlled by the PI (Proportional-integral) cooling loop and cooling stages capacity algorithm. The algorithm calculates the desired number of stages needed to satisfy the space by comparing the control temperature (return air or space) to the appropriate cooling setpoint.

NOTE: The waterside economizer, if applicable, is used for first stage cooling, in addition to the compressor(s). The following conditions must be true for the cooling algorithm to run:

- Cooling is set to Enable.
- The Fire/Smoke Input and Shutdown modes are inactive.
- Heat mode is not active and the compressor time guard(s) have expired.
- Condensate overflow alarm status is Normal.
- Fan Status is True (if option is enabled).
- If occupied, the control temperature is greater than the occupied cooling setpoint.
- Control temperature reading is valid.

1. Third-party trademarks and logos are the property of their respective owners.

- If unoccupied, the control temperature is greater than the unoccupied cooling setpoint.
- If economizer cooling is available and active, and the economizer alone is insufficient to provide enough cooling.
- OAT > Cooling Lockout Temperature if OAT is available.
- Source water pump is on (if source water linkage is active)
- Water Flow Switch Status is True (if option is enabled).

If all of the above conditions are met, the compressors' relays are energized as required. Otherwise, they will be de-energized. If cooling is active and if the SAT approaches the minimum SAT limit, the fan will be indexed to the next higher speed. If this is insufficient, and if the SAT falls further (equal to the minimum SAT limit), the fan will be indexed to the maximum speed. If the SAT still continues to fall 5°F below the minimum SAT limit, all cooling stages will be disabled.

During Cooling, the reversing valve output is held in the cooling position (either B or O type, as configured), even after the compressor is stopped. The valve does not switch position until the heating mode is required.

The configuration screens contain the Min SAT parameter as well as Cooling Lockout based on outdoor air temperature (OAT). Both can be adjusted to meet various specifications.

HEATING OPERATION

Space Temperature Control (Reverse Cycle Heating)

The TruVu™ controller operates 1 or 2 stages of compression to maintain the desired heating setpoint. The compressor outputs are controlled by the heating PI (Proportional-integral) loop and heating stages capacity algorithm. The algorithm calculates the desired number of stages needed to satisfy the space by comparing the control temperature (return air or space) to the appropriate heating setpoint.

The following conditions must be true for the heating algorithm to run:

- Heating is set to Enable.
- The Fire/Smoke Input and Shutdown modes are inactive.
- Cool mode is not active and the compressor time guard has expired.
- Condensate overflow alarm status is Normal.
- Fan Status is True (if option is enabled).
- If occupied, the control temperature is less than the occupied heating setpoint.
- Control temperature reading is valid.
- If unoccupied, the control temperature is less than the unoccupied heating setpoint.
- OAT > < Heating Lockout Temperature if OAT is available.
- Source Water Pump is on (if Source Water Linkage active).
- Water Flow Switch Status is True (if option is enabled).

If all the above conditions are met, the heating outputs are energized as required, otherwise they are de-energized. If heating is active and the SAT approaches the maximum SAT limit, the fan is indexed to the next higher speed. If this is insufficient, and if the SAT rises further and reaches the Maximum Heating SAT limit, the fan is indexed to the maximum speed. If the SAT still continues to rise 5°F above the maximum limit, all heating stages are disabled.

Space Temperature Control (Reverse Cycle Heating and Auxiliary Heat)

The TruVu™ controller can control a 2-position or modulating water or steam valve, connected to a coil on the discharge side of the unit and supplied by a boiler, or a single stage ducted electric heater, in order to maintain the desired heating setpoint. If the compressor capacity is insufficient, or a compressor failure occurs, the auxiliary heat is used. Unless the compressor fails, the auxiliary heat only operates to supplement the heat provided by

the compressor, if the space temperature falls more than 1°F below the desired heating setpoint. (This amount is configurable.) The heat is controlled so the SAT does not exceed the Maximum Heating SAT limit.

The same conditions required for Reverse Cycle Heating must be true in order for the Auxiliary Heat algorithm to run.

2-Position Hot Water / Steam Heating

The control can operate a 2-position, NO or NC, hot water or steam valve, connected to a coil on the discharge side of the unit and supplied by a boiler, in order to maintain the desired heating setpoint, if the compressor capacity is insufficient or a compressor failure occurs. Unless a compressor fault condition exists, the valve only opens to supplement the heat provided by the compressor, if the space temperature falls more than 1°F below the desired heating setpoint. The valve is controlled so the SAT does not exceed the Maximum Heating SAT limit and is subject to a 2-minute minimum OFF-time to prevent excessive valve cycling.

“Boilerless” Control (Auxiliary Heat)

The TruVu™ controller can be configured to control the auxiliary heat source for “boilerless” types of systems or system with no means for heat injection into the source water loop. Compressor will be disabled, and the auxiliary heat source will be enabled when the entering water temperature drops below the configurable boilers electric heat setpoint.

Indoor Air Quality and Demand Control Ventilation

If the optional hardwired indoor air quality sensor is installed, ZS CO₂ (IAQ), or the System Space AQ network input point is used, the TruVu™ controller maintains indoor air quality with a modulating OA damper, which provides demand controlled ventilation. The control operates the modulating OA damper during occupied periods, monitors the CO₂ level, compares it to the configured setpoints, and adjusts the ventilation rate, as required. The control provides proportional ventilation to meet the requirements of ASHRAE specifications by providing a base ventilation rate and then increasing the rate as the CO₂ level increases. The control proportionally increases ventilation when the CO₂ level rises above the start ventilation setpoint and reaches the full ventilation rate when the CO₂ level is at or above the maximum setpoint.

Configure the minimum damper position to ensure that proper base ventilation is delivered when occupants are not present. Access the IAQ configurations through the configuration screen.

The following conditions must be true in order for this algorithm to run:

- Damper Control is configured for DCV.
- The Fire/Smoke Input and Shutdown modes are inactive.
- Fan status is True (if option is enabled).
- The unit is in an occupied mode.
- IAQ sensor reading is greater than the DCV start CTRL setpoint.

The control has the following 4 adjustable setpoints:

- DCV Start Ctrl Setpoint
- DCV Max Ctrl Setpoint
- Minimum Damper Pos
- DCV Max Vent Damper Pos

NOTE: For the damper to maintain proper base ventilation, you must configure the fan as Continuous or Always On.

2-Position OA Damper

Alternatively, the controller can be configured to operate as a ventilation damper in a 2-position ventilation mode to provide the minimum ventilation requirements during occupied periods.

Differential Pressure Switch / Water Flow Switch

The flow switch monitors the pressure difference between two points on the waterside. An optional input can be configured as condenser water flow status input. If configured, the flow status must be ON for 3 seconds to enable the compressors.

COMPRESSOR STATUS

The TruVu™ controller provides a status input to monitor the compressor operation. The status is monitored to determine if the compressor status matches the commanded state. This input is used to determine if a refrigerant safety switch or other safety device has tripped and caused the compressor to stop operating normally. If this occurs, an alarm is generated to indicate the faulted compressor condition.

DEMAND LIMITING

The TruVu™ controller can accept 3 levels of demand limit from the BACnet®¹ network. In response to a demand limit, the unit decreases its heating setpoint and increases its cooling setpoint to widen the range, in order to immediately lower the electrical demand. You can configure the temperature adjustment for both heating and cooling and for each demand level. You can also set the response to a particular demand level to 0.

REMOTE DISABLE

Fire/Smoke Detector Input

The TruVu™ controller can read the status of a normally closed FSD contact input to determine if a fire or smoke detector alarm is present. If the controller determines an alarm condition is present, all heating, cooling, and the fan are disabled. The switch is factory-set to Normally Closed and cannot be changed.

Shutdown Input

The TruVu™ controller has a shutdown input (software point) which, when set to its Active mode causes the WSHP to safely shutdown in a controlled fashion. Heating and cooling is disabled after any minimum runtime conditions expire and the fan is disabled after the fan-off timer expires. All alarms are reset but any active alarm remains active. After the shutdown input transitions from Active mode to Inactive, the TruVu™ controller restarts after the configured power fail restart delay expires.

ALARMS

High Discharge Pressure (UPM Alarm)

The TruVu WSHP monitors the status of a high discharge pressure fault condition via the serial port (S1). The fault condition is determined by the Unit Protection Module (UPM) included on all WSHPs. The UPM monitors a high-pressure switch input and establishes a high-pressure fault when the discharge pressure exceeds 600 psig. Upon fault a 5-minute break is initiated (soft lockout) and the compressor is disabled. The unit will automatically restart after this time period. If the fault occurs 2 times (configurable on UPM) within 60 minutes the UPM will put the unit into hard lockout requiring manual reset. Manual reset can be accomplished remotely when the UPM is configured for the reset method “Y” by remotely disabling the unit via the TruVu WSHP.

Low Suction Pressure (UPM Alarm)

The TruVu WSHP monitors the status of a low suction pressure fault condition via the serial port (S1). The fault condition is determined by the Unit Protection Module (UPM) included on all WSHPs. The UPM monitors a low-pressure switch input and establishes a high-pressure fault when the discharge pressure drops below 40 psig. Upon fault a 5-minute break is initiated (soft lockout) and the compressor is disabled. The unit will automatically restart after this time period. If the fault occurs 2 times (configurable on UPM) within 60 minutes the UPM will put the unit into hard lockout requiring manual reset. Manual reset can be accomplished remotely when the UPM is configured for the

reset method “Y” by remotely disabling the unit via the TruVu WSHP.

Air Coil Freeze Alarm (UPM Alarm)

The TruVu WSHP monitors the status of an air coil freeze fault condition via the serial port (S1). The fault condition is determined by the Unit Protection Module (UPM) included on all WSHPs. The UPM monitors the heating liquid line refrigerant temperature and establishes a high-pressure fault if the temperature drops below 26°F (configurable on UPM) for 30 seconds. Upon fault a 5-minute break is initiated (soft lockout) and the compressor is disabled. The unit will automatically restart after this time period. If the fault occurs 2 times (configurable on UPM) within 60 minutes the UPM will put the unit into hard lockout requiring manual reset. Manual reset can be accomplished remotely when the UPM is configured for the reset method “Y” by remotely disabling the unit via the TruVu™ WSHP.

Water Coil Freeze Alarm (UPM Alarm)

The TruVu WSHP monitors the status of a water coil freeze fault condition via the serial port (S1). The fault condition is determined by the Unit Protection Module (UPM) included on all WSHPs. The UPM monitors the cooling liquid line refrigerant temperature and establishes a high-pressure fault if the temperature drops below 26°F (configurable on UPM) for 30 seconds. Upon fault a 5-minute break is initiated (soft lockout) and the compressor is disabled. The unit will automatically restart after this time period. If the fault occurs 2 times (configurable on UPM) within 60 minutes the UPM will put the unit into hard lockout requiring manual reset. Manual reset can be accomplished remotely when the UPM is configured for the reset method “Y” by remotely disabling the unit via the TruVu WSHP.

Condensate Overflow Alarm (UPM Alarm)

The TruVu WSHP monitors the status of a condensate overflow fault condition via the serial port (S1). The fault condition is determined by the Unit Protection Module (UPM) included on all WSHPs. The UPM monitors a condensate overflow switch and upon fault puts the unit in a hard lockout condition, disabling the compressor. The hard lockout condition requires manual reset. Manual reset can be accomplished remotely when the UPM is configured for the reset method “Y” by remotely disabling the unit via the TruVu WSHP.

Brownout Alarm (UPM Alarm)

The TruVu WSHP monitors the status of a brownout fault condition via the serial port (S1).

Fire/Smoke Detector Alarm

The control monitors the voltage input to J1-9 to detect if a smoke detector or fire detector NC contact has opened, indicating an alarm condition. The control verifies the presence of 24 vac on this input. If the input opens at any time, an alarm is generated after 3 seconds and the equipment (fan, compressor, aux heat, and damper) immediately shuts down.

Space Temperature Alarms

The control provides the ability to generate an alarm when the space temperature exceeds the alarm setpoint. A separate occupied hysteresis and fixed unoccupied high and low alarm setpoints are provided. The control provides a 5-minute alarm delay during unoccupied periods. During occupied periods, the control uses the occupied temperature setpoint and applies the hysteresis value to determine the alarm setpoints. When occupancy transitions from unoccupied to occupied or the occupied temperature setpoints are changed, causing an alarm condition to occur, the control automatically calculates an alarm delay (equivalent to the configured delay time in minutes/ °F, multiplied by the temperature error, + 15 minutes). This prevents nuisance alarms when an occupancy change occurs and allows time for the unit to correct an alarming temperature condition.

1. Third-party trademarks and logos are the property of their respective owners.

Source Water Temperature Alarm

The control has 4 configurable alarm limits for source water temperature. The control verifies that the water temperature is within operating range (between high and low limits) for the specific operating mode (heating or cooling) before energizing the compressor. Once the compressor is started, the source water temperature is further monitored to verify that it is within limits to insure sufficient water is flowing through the coil. If the leaving water temperature rises above or falls below the appropriate limits, and lasts for more than 15 seconds, an alarm is generated and the compressor shuts down.

Supply Air Temperature Alarm

The control has 2 configurable alarm limits for supply air temperature. The control verifies that the supply air temperature is within operating range (between high and low limits) when the compressor or auxiliary heat is operating. If the air temperature rises above or falls below the appropriate limits, and this lasts for more than 5 minutes, an alarm is generated.

Fan Status Alarm

The control generates a fan status alarm if the fan status input detects the fan is OFF after any fan speed output has been enabled. A 30-second alarm delay is used to allow the fan to start operation before an alarm condition is detected. The control monitors the fan output and if the fan is operating at any speed, the fan status must detect the fan is operating.

Compressor Status Alarm

The control generates a compressor failure alarm if the compressor status input detects the compressor is OFF after the compressor output has been energized. A 6-minute alarm delay is used to allow the compressor to start (prevents alarms due to timeguard operation) before an alarm condition is detected. The control monitors the compressor output and if the compressor output is energized, the compressor status input must detect the compressor operation.

Filter Status Alarm

The control provides the ability to generate a dirty filter alarm after the number of fan run hours exceeds a configurable filter alarm timer limit. The control monitors the fan output and if the fan is operating at any speed, it accumulates run time. If the fan run time hours exceed the configurable limit, an alarm is generated. To reset the alarm timer after the alarm has been generated, a Reset Filter Alarm input is provided. You can disable the filter alarm by setting the Filter Alarm Timer Delay to 0 (factory default).

Indoor Air Quality Alarm

The control provides the ability to generate a high CO₂ level alarm during occupied periods when the CO₂ sensor value exceeds the adjustable limit. When a transition from unoccupied to occupied occurs, or the occupied alarm limit is changed to a value that causes an alarm condition to occur, the control will automatically calculate an alarm delay (equivalent to the configured delay time in minutes/ppm, times the error that occurred, + 15 minutes). This prevents nuisance alarms from occurring when occupancy changes or the setpoint is changed. You can disable the IAQ alarm by setting Occupied High IAQ Alarm Limit to 0.

Relative Humidity Alarm

The control provides the ability to generate an alarm when the space relative humidity exceeds the alarm setpoint. Separate occupied and unoccupied high humidity alarm setpoints are provided. The control provides a 5-minute alarm delay during unoccupied periods. During occupied periods, the controller uses the occupied high RH alarm limit. When an occupancy transition from unoccupied to occupied occurs, or the occupied high alarm limit is lowered, causing an alarm condition to occur, the control automatically calculates an alarm delay (equivalent to the configured delay time in minutes/% RH, times the humidity error condition that occurred, + 15 minutes). This prevents nuisance alarms when an occupancy change occurs and allows time for the unit to correct an alarming humidity condition.

Source Water Linkage Failure Alarm (if Source Water Linkage was active)

The control generates a Source Water Linkage failure alarm if Linkage fails after once being active. The Linkage status is monitored and if it fails to be updated from the Loop controller, then a Source Water Linkage alarm is generated. There is a 6-minute alarm delay to prevent false alarms.

NOTE: You can reset this alarm only by re-establishing Linkage and correcting the condition that caused the Linkage failure, or by momentarily setting the Shutdown point to Active.

Airside Linkage Failure Alarm (if Airside Linkage was active)

The control generates an Airside Linkage failure alarm if Linkage fails after once being active. The Linkage status is monitored and if it fails to be updated from the master zone controller, then an Airside Linkage alarm is generated. There is a 6-minute alarm delay to prevent false alarms.

NOTE: You can reset this alarm only by re-establishing Linkage and correcting the condition that caused the Linkage failure, or by momentarily setting the Shutdown point to Active.

OAT Sensor Alarm (if Network OA Temperature was active)

The control generates an OAT Sensor failure alarm if the value of OAT fails to be updated through the network after once being active. The update status is monitored and if it fails to be updated, then an OAT sensor alarm is generated. There is an alarm delay (approximately 1 hour) to prevent false alarms, while minimizing the required update rate for OAT.

NOTE: You can reset this alarm by momentarily setting the Shutdown point to Active.

SPT Sensor Alarm (if SPT sensor was active)

The control generates an SPT sensor failure alarm if the SPT sensor fails to communicate with the control for 5 minutes or greater. The update status is monitored and if it fails to be updated, then an SPT sensor alarm is generated.

ZS Sensor Alarm (if ZS sensor was active)

The control generates a ZS sensor failure alarm if the ZS sensor fails to communicate with the control for 5 minutes or greater. The update status is monitored and if it fails to be updated, then a ZS sensor alarm is generated.

UPM Alarm - Hard lockout status

The control generates Alarm when Hard lockout Alarm is active on UPM board. Configurable 2 or 4 soft lockout alarms on UPM board before unit enters to hard lock out. Soft lockout alarm history is available via controller.

Low Water Flow Alarm

The control monitors differential pressure switch (water flow switch), and generates alarm if water flow is not met. This alarm is presented only if unit is provided with differential (flow) pressure switch option.

Air Side Delta T Alarm

The control has 4 configurable alarm limits for Air Side Delta T.

The control verifies that the calculates delta T based on Return and Supply Air temperatures reading and verifies if it operates within configured ranged (between high and low limits) for the specific operating mode (heating or cooling) before energizing the compressor.

Source Water Valve Alarm

The control generates alarm if communication with Act Net device is lost.

Water Side Delta T Alarm

The control has 4 configurable alarm limits for Source water Delta T.

The control verifies that the calculates delta T based on Entering and Leaving water temperatures reading and verifies if it operates

within configured range (between high and low limits) for the specific operating mode (heating or cooling) before energizing the compressor.

Entering Water Temperature Alarm

The control has 4 configurable alarm limits for Entering Water temperature.

The control verifies that the entering water temperature is within operating range (between high and low limits) for the specific operating mode (heating or cooling) before energizing the compressor. Once the compressor is started, the entering water temperature is further monitored to verify that it is within limits to insure sufficient water is flowing through the coil. If the entering water temperature rises above or falls below the appropriate limits, and lasts for more than 15 seconds, an alarm is generated and the compressor shuts down.

Return Air Temperature Alarm (if RAT sensor is field provided)

The control has 2 configurable alarm limits for return air temperature. The control verifies that the return air temperature is within operating range (between high and low limits) when unit is operating. If the air temperature rises above or falls below the appropriate limits, and this lasts for more than 5 minutes, an alarm is generated.

UNIT-MOUNTED CONTROLLER

Designed to enhance the unit operation with more flexibility, accurate control and operating modes the unit-mounted controller provides an increased level of comfort in the conditioned space together with solid-state reliability and ease of operation. See Fig. 21.

Units with Unit Mounted Controller (UMC) controller still feature a UPM board for unit operation and have all safety features included with UPM board. (See Fig. 15 — on page 24). Unit-mounted controllers are standard on all console units except for remote options.

- Tactile touch pad for temperature, fan and mode adjustment
- Digital display of temperature in either degrees Fahrenheit or Celsius
- LED display provides indication for unit operating mode as well as fan speed and fault indication for high or low pressure lockout
- Adjustable Temperature Set point from 60°F through 80°F (15.5°C through 26.7°C)
- Adjustable Temperature Differential between 1°F and 6°F (0.6°C and 3.3°C)
- Selectable options:
 - Manual/Automatic changeover
 - Fan speed – High or Low
 - Fan operation constant fan or cycling with compressor

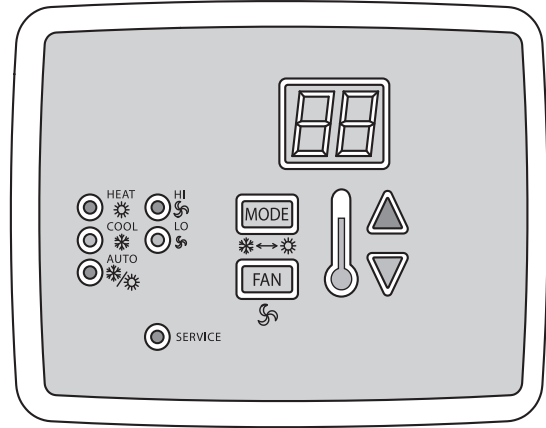

Fig. 21 — Unit Mounted Controller

MAINTENANCE

Filter changes or cleaning are required at regular intervals. See Fig. 22 for piping and schematic locations. The time period between filter changes will depend upon the type of environment the equipment is used in. In a single family home that is not under construction, changing or cleaning the filter every 60 days is sufficient. In other applications such as motels, where daily vacuuming produces a large amount of lint, filter changes may be need to be as frequent as biweekly.

NOTE: Equipment should never be used during construction due to likelihood of wall board dust accumulation in the air coil of the equipment, which permanently affects the performance and may shorten the life of the equipment.

An annual “checkup” is required by a licensed refrigeration technician. Recording the performance measurements of volts, amps, and water temperature differences (both heating and cooling) is recommended. This data should be compared to the information on the unit’s data plate and the data taken at the original start-up of the equipment.

The condensate drain must be checked annually by cleaning and flushing to ensure proper drainage.

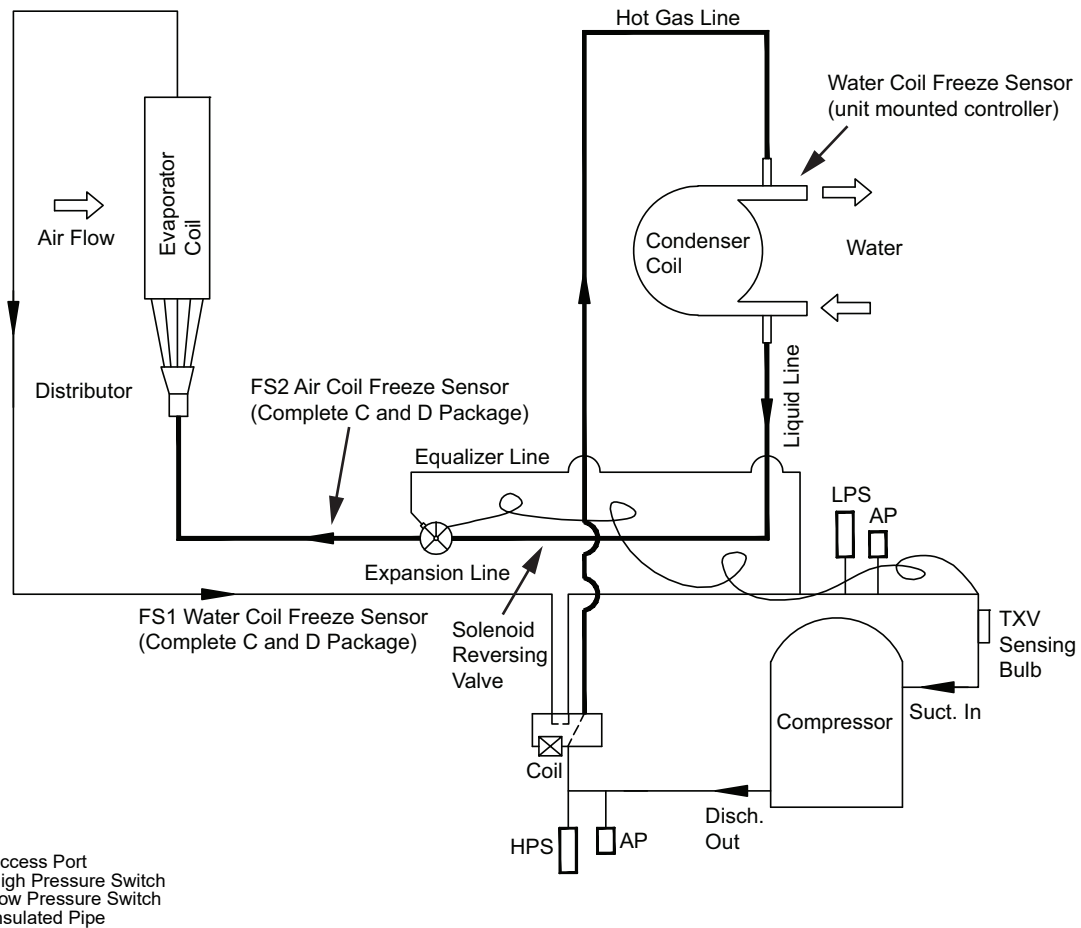

Fig. 22 — Piping and Sensor Schematic

TROUBLESHOOTING

Troubleshooting Checks and Correction column in Table 10 may reflect a possible fault that may be one of, or a combination of causes and solutions. Check each cause and adopt “process of elimination” and/or verification of each before making any conclusion.

Periodic lockouts almost always are caused by air or water flow problems. The lockout (shutdown) of the unit is a normal protective measure in the design of the equipment. If continual lockouts occur, call a technician immediately and have them check for: water flow problems, water temperature problems, air flow problems or air temperature problems. Use of the pressure and temperature charts for the unit may be required to properly determine the cause.

Table 10 – Troubleshooting

PROBLEM	POSSIBLE CAUSE	CHECKS AND CORRECTION
ENTIRE UNIT DOES NOT RUN	Power Supply Off	Apply power, close disconnect.
	Blown Fuse	Replace fuse or reset circuit breaker. Check for correct fuses
	Voltage Supply Low	If voltage is below minimum voltage specified on unit data plate, contact local power company.
	Thermostat	Set the fan to “ON”; the fan should run. Set thermostat to “COOL” and lowest temperature setting; the unit should run in the cooling mode (reversing valve energized). Set unit to “HEAT” and the highest temperature setting, the unit should run in the heating mode. If neither the blower nor the compressor run in all three cases, the thermostat could be miswired or unit-mounted controller faulty. To ensure miswired or faulty thermostat verify 24 volts is available on the condensing section low voltage terminal strip between “R” and “C,” “Y” and “C,” and “O” and “C.” If the blower does not operate, verify 24 volts between terminals “G” and “C” in the air handler. Replace the thermostat if defective.
BLOWER OPERATES BUT COMPRESSOR DOES NOT	Thermostat	Check setting, calibration, and wiring.
	Wiring	Check for loose or broken wires at compressor, capacitor, or contactor.
	Safety Controls	Check UPM board Alarm LED for blink code.
	Compressor Overload Open	If the compressor is cool and the overload will not reset, replace compressor.
	Compressor Motor Grounded	Internal winding grounded to the compressor shell. Replace compressor. If compressor burnout, install suction filter drier.
Compressor Windings Open	After compressor has cooled, check continuity of the compressor windings. If the windings are open, replace the compressor.	
UNIT OFF ON HIGH PRESSURE CONTROL	Discharge Pressure Too High	In “COOLING” mode: Lack of or inadequate water flow. Entering water temperature is too warm. Scaled or plugged condenser. In “HEATING” mode: Lack of or inadequate air flow. Blower inoperative, clogged filter or restrictions in duct work.
	Refrigerant Charge	The unit is overcharged with refrigerant. Recover refrigerant, evacuate and recharge with factory recommended charge.
	High Pressure Switch	Check for defective or improperly calibrated high pressure switch.
UNIT OFF ON LOW PRESSURE CONTROL	Suction Pressure Too Low	In “COOLING” mode: Lack of or inadequate air flow. Entering air temperature is too cold. Blower inoperative, clogged filter or restrictions in duct work. In “HEATING” mode: Lack of or inadequate water flow. Entering water temperature is too cold. Scaled or plugged condenser.
	Refrigerant Charge	The unit is low on refrigerant. Check for refrigerant leaks, repair, evacuate and recharge with factory recommended charge.
	Low Pressure Switch	Check for defective or improperly calibrated low pressure switch.
UNIT SHORT CYCLES	Unit Oversized	Recalculate heating and or cooling loads.
	Thermostat	Thermostat installed near a supply air grill; relocate thermostat. Readjust heat anticipator.
	Wiring and Controls	Check for defective or improperly calibrated low pressure switch.
INSUFFICIENT COOLING OR HEATING	Unit Undersized	Recalculate heating and or cooling loads. If excessive, possibly adding insulation and shading will rectify the problem.
	Loss of Conditioned Air By Leakage	Check for leaks in duct work or introduction of ambient air through doors or windows.
	Airflow	Lack of adequate air flow or improper distribution of air. Replace dirty filter.
	Refrigerant Charge	Low on refrigerant charge causing inefficient operation.
	Compressor	Check for defective compressor. If discharge is too low and suction pressure is too high, compressor is not pumping properly. Replace compressor.
	Reversing Valve	Defective reversing valve creating bypass of refrigerant from discharge of suction side of compressor. Replace reversing valve.
	Operating Pressures	Compare unit operation pressures to the pressure/temperature chart for the unit.
TXV	Check thermostatic expansion valve (TXV) for possible restriction or defect. Replace if necessary.	
Moisture, Non Condensable	The refrigerant system may be contaminated with moisture or non condensable. Recover refrigerant, replace filter dryer, evacuate the refrigerant system, and recharge with factory recommended charge.	

**50PEC UNIT
START-UP CHECKLIST**

NOTE: To avoid injury to personnel and damage to equipment or property when completing the procedures listed in this start-up checklist, use good judgment, follow safe practices, and adhere to the safety considerations/information as outlined in preceding sections of this Installation, Start-Up and Service document.

Customer: _____ Job Name: _____
 Model No.: _____ Serial No.: _____ Date: _____

I. PRE-START-UP

- Does the unit voltage correspond with the supply voltage available? (Y/N) _____
- Have the power and control wiring connections been made and terminals tight? (Y/N) _____
- Is the control transformer set to the correct voltage? (Y/N) _____
- Have water connections been made and is fluid available at heat exchanger? (Y/N) _____
- Has pump been turned on and are isolation valves open? (Y/N) _____
- Has condensate connection been made and is a trap installed? (Y/N) _____
- Is an air filter installed and cleaned? (Y/N) _____
- Has the fan speed selector switch been set to the desired setting? (Y/N) _____

II. START-UP

Is fan operating when compressor operates? (Y/N) _____

UNIT VOLTAGE — COOLING OPERATION

Phase AB volts _____
 Phase AB amps _____

CONTROL VOLTAGE

Is control voltage above 21.6 volts? (Y/N) _____.
 If not, check for proper transformer connection.

TEMPERATURES

Fill in the analysis chart attached.

COAXIAL HEAT EXCHANGER	COOLING CYCLE:	_____ F	WATER OUT	_____ F	_____ FT WG	_____ GPM
	HEATING CYCLE:	_____ F	WATER OUT	_____ F	_____ FT WG	_____ GPM
AIR COIL	COOLING CYCLE:	_____ F	AIR OUT	_____ F		
	HEATING CYCLE:	_____ F	AIR OUT	_____ F		

HEATING CYCLE ANALYSIS

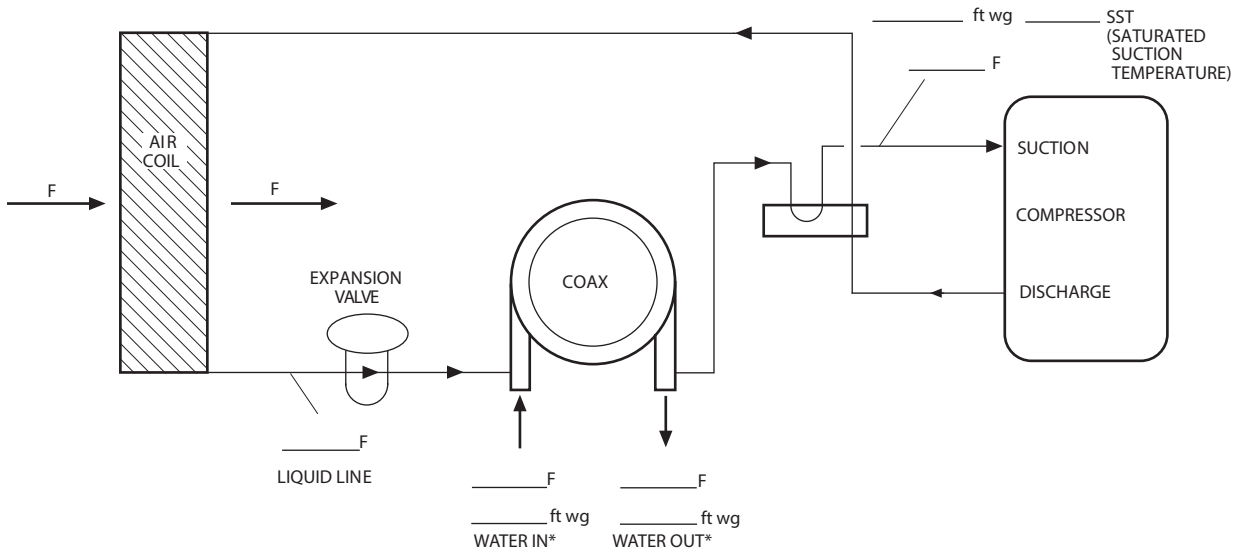

COOLING CYCLE ANALYSIS

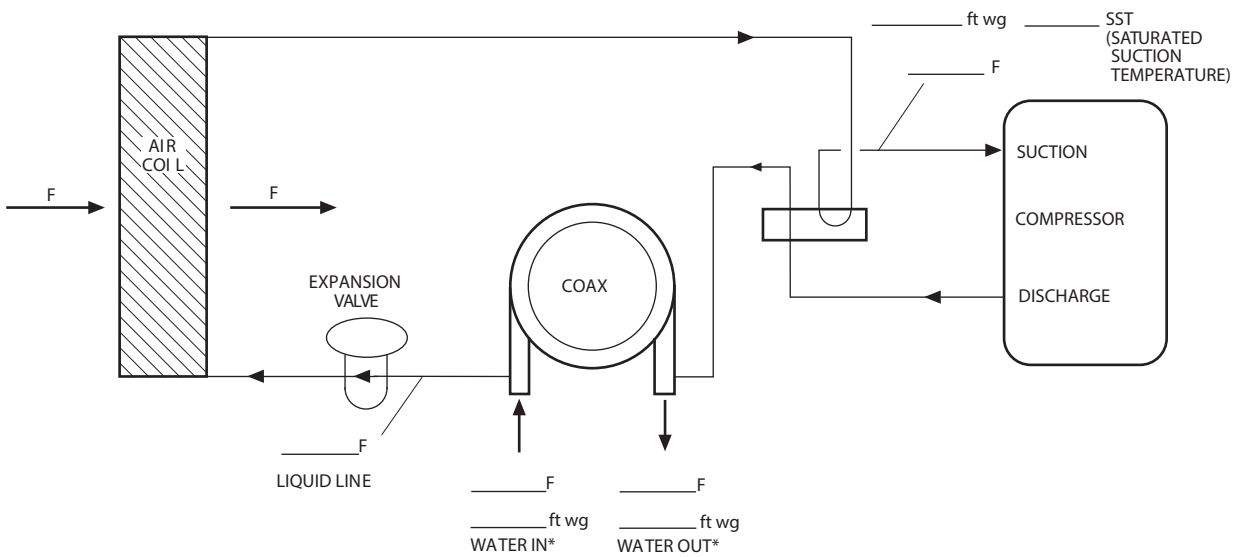

HEAT OF EXTRACTION (ABSORPTION) OR HEAT OF REJECTION =

$$\text{_____ FLOW RATE (gpm)} \times \text{_____ TEMP. DIFF. (DEG. F)} \times \text{_____ FLUID FACTOR} \dagger = \text{_____}$$

(Btu/hr)

$$\text{SUPERHEAT} = \text{SUCTION TEMPERATURE} - \text{SATURATED SUCTION TEMPERATURE}$$

$$= \text{_____ (DEG F)}$$

$$\text{SUBCOOLING} = \text{SATURATED CONDENSING TEMPERATURE} - \text{LIQUID LINE TEMPERATURE}$$

$$= \text{_____ (°F)}$$

*Look up pressure drop in Fig. 14 to determine flow rate.

†Use 500 for water, 485 for antifreeze.

CUT ALONG DOTTED LINE