



Controls, Operation, Start-Up and Troubleshooting

CONTENTS

	Page
SAFETY CONSIDERATIONS	3
A2L REFRIGERANT CONSIDERATIONS	3
Work Area	3
Leak Detection	3
A2L Refrigerant Leak Detection System Interlock	4
Unit Charge	4
Checks to Electrical Devices	5
GENERAL	5
Airflow Process	5
Refrigeration System	5
• EVAPORATOR (INDOOR COIL)	
• CONDENSER (OUTDOOR COIL)	
• REHEAT SYSTEM	
Heating System	6
• DX HEAT PUMP	
• GAS HEAT	
• ELECTRIC HEAT	
• HOT WATER HEAT	
Filtration System	10
Energy Recovery Ventilator	10
Exhaust Fan	10
Supply Fan	10
CONTROLS	10
Control Configuration	10
Controller Ports	10
• UNIVERSAL INPUTS	
Communication	13
• LOCAL RNET ACCESS PORT	
EQUIPMENT TOUCH™ DEVICE	14
General	14
Device Connection	14
Equipment Touch Usage	15
Access Control	15
• USER (REQUIRES NO PASSWORD)	
• ADMIN (REQUIRES PASSWORD 1111)	
• FACTORY (REQUIRES FACTORY PASSWORD)	
CONTROL NAVIGATION	16
General	16
Standby Screen	16
Home Screen	16
Status Screens	16
Damper Status	16
Set Points Screens	20
• SET POINTS SCREENS OVERVIEW	
Fan Set Points	20
ECW Set Points	20
Cooling 1 Set Points	20
• COOLING 1 ENABLE	
• COOLING 1 MOD	
• COOLING	
Cooling 2 Set Points	21
• COOLING 2 ENABLE	
Dehumidification Set Points	21
• DEHUM ENABLE	
• DEHUM	
• DEADBAND	
Heating Set Points	21
• HEATING 1 ENABLE	
• HEATING	
• DEADBAND	
Heat Pump Heating Set Points (62H, 62L and 62W Heat Pumps Only)	22
• HEAT PUMP 1 AND 2 ENABLE	
• HEATING	
• DEADBAND	
Limits/Safety Set Points	22
• CLG MODE LO LIMIT	
• DH MODE LO LIMIT	
• HTG MODE HI LIMIT	
• COMP 1 DISABLE/COMP 2 DISABLE	
• UPPER FREEZE	
• MIDDLE FREEZE	
• LOWER FREEZE	
• ECW DEFROST	
Unoccupied Set Points (Units with Night Setback ETO only)	23
• COOLING	
• DEHUMIDIFY	
• HEATING	
Tech Settings	23
Unit Control Configuration	23
• ZONE SENSOR OPTION	
• PUSH-BUTTON OVERRIDE	
• ZONE SET POINT ADJUST TECH SET UP	
• SET POINT ADJUST LIMIT (+/-)	
• NIGHT SET BACK (NSB) OPTION	
• MISC OPTIONS A	
• MISC OPTIONS B	
Tech Settings	24
• OCCUPANCY CONTROL	
• MANUAL OCC CONTROL	
• ENABLE UNIT OPERATION	
• EMERGENCY SHUTDOWN	
• EMERGENCY HEAT ENABLE (62H, 62L, AND 62W HEAT PUMPS ONLY)	
• SF MINIMUM SETTING	
• SF HP MINIMUM SETTING	

• ZAT/SAT RESET	• MANUAL RESET
• HWV MINIMUM OUTPUT	• ALARMS AFTER START-UP
• SUPPLY FAN OCCUPIED/UNOCCUPIED OPERATION	• SAFETY SWITCHES
• SCHEDULES	• SAFETY SHUTDOWN
• VIEWING LOCAL SCHEDULES	SENSORS 42
• ADDING NEW LOCAL SCHEDULES	Zone Air Temperature Sensor (Carrier ZS2) 43
• ADDING MULTIPLE PERIODS TO A SCHEDULE	• INSTALLATION
Sensor Calibration 26	Multiple ZS Sensors-Wiring and Set Up 44
• SUPPLY AIR TEMPERATURE (SAT) RESET	Supply Air Temperature and Relative Humidity Sensor (SAT/RH) 45
• SAT RESET OPERATION	SAT/RH SENSOR INSTALLATION 45
Manual Override 26	• SENSOR MOUNTING
Differential Pressure Transmitter Summary 27	• SENSOR WIRING AND CONFIGURATION
Airflow Monitor Station (AMS) Summary 27	• CONTROLLER WIRING AND CONFIGURATION
Supply Fan and Exhaust Fan AMS Settings 27	Differential Pressure Transmitter (DPT) 48
Miscellaneous Settings 27	• INSTALLATION
Building Automation System (BAS) Module Set Up .27	Clogged Filter Indicator 49
Set Time and Date 28	• SET UP
Communication 28	• RESET
• MAX MASTERS	Phase Monitor 49
• MAX INFO FRAMES	Energy Management Relay 49
Network Router 28	VFD Control 49
IP Settings 29	Hot Water Heating Control 53
Time Master 29	Inverter Driven Compressor 53
Module Status (Modstat) 29	Condenser Water Regulating Valves and Head Pressure Control 53
PID Settings 29	HEATING 56
Equipment Touch Set Up 29	Set Points 56
Equipment Configuration 29	Ignition Control 56
• SF OPTION	Flame Current Sensor 57
• EF OPTION	• SERVICE CHECKS
• HGRH OPTION	Staged Heat 58
• DEHUM OPTIONS	• CALL FOR HEAT
• HEATING OPTIONS	• IGNITION AND OPERATIONAL FAILURES DURING A CALL FOR HEAT RESULT IN “LOCKOUT” OF THE IGNITION CONTROL
• COOLING ENABLED BY	• RECOVERY FROM LOCKOUT
• HEATING ENABLED BY	• IC FAULT CONDITIONS AND LED KEY
• TEMP OPTIONS #1	Draft Fan Pressure Measurement HM Series Heat Module 61
• TEMP OPTIONS #2	Manifold Pressures 62
• HUMIDITY OPTIONS #1 AND #2	Modulating Gas Heat 62
• AIR PRESSURE OPTIONS	• MODULATING GAS VALVE
Archive Program 31	• SIGNAL CONDITIONER (SC30)
• RESTORING FROM ARCHIVE	• INDUCER FAN SPEED CONTROL
Test Mode 32	• TIMER RELAY CONTROL (TR1)
• SUPPLY FAN TEST MODE	• SEQUENCE OF OPERATION FOR ELECTRONIC MODULATION WITH INDUCER SPEED CONTROL
• EXHAUST FAN TEST MODE	• CALL FOR HEAT
• COOLING TEST MODE	• IGNITION AND OPERATIONAL FAILURES DURING A CALL FOR HEAT RESULT IN “LOCKOUT” OF THE IGNITION CONTROL
• DEHUMIDIFICATION TEST MODE	• RECOVERY FROM LOCKOUT
• HEATING TEST MODE	• FAULT CONDITIONS AND LED KEY
OPERATION 33	Electric Heat 66
General 33	SCR Controlled Electric Heat 68
Occupied Mode 34	ENERGY RECOVERY VENTILATOR CONTROL .. 70
• OUTDOOR AIR DAMPER (OD)	VFD Defrost 70
• SUPPLY FAN (SF)	ERV Maintenance 70
• EXHAUST FAN (EF)	ELECTRICAL DATA 70
• ZAT/SAT SET POINT RESET	Wiring Diagrams 70
• ENERGY CONSERVATION WHEEL (ECW)	62W Electrical Data 70
• COOLING MODE	Setting up AUTOBAUD 82
• DEHUMIDIFICATION MODE (FIELD ENABLED)	• TO SET A CUSTOM IP ADDRESS
• HEATING MODE	
• UNOCCUPIED MODE	
• SAFETY SWITCHES	
ALARMS 40	
Alarm Status 40	
• CLEARING ALARMS	
Alarm Matrix 40	
• AUTOMATIC RESET	

APPENDIX A — BAS COMMISSIONING 82
**APPENDIX B — OPERATING MODES AND
CONDITIONS 92**
**APPENDIX C — EQUIPMENT QUICK START-UP
GUIDANCE 93**
**APPENDIX D — CONTROL NAVIGATION
DIAGRAM 97**
APPENDIX E — AIR BALANCE INSTRUCTIONS . . 100
CHECKLISTS CL-1

SAFETY CONSIDERATIONS

Installation and servicing of air-conditioning equipment can be hazardous due to system pressure and electrical components. Only trained and qualified service personnel should install, repair, or service air-conditioning equipment. Untrained personnel can perform the basic maintenance functions of replacing filters. Trained service personnel should perform all other operations.

When working on air-conditioning equipment, observe precautions in the literature, tags and labels attached to the unit, and other safety precautions that may apply. Follow all safety codes. Wear safety glasses and work gloves. Use quenching cloth for unbrazing operations. Have fire extinguishers available for all brazing operations.

⚠ WARNING

Before performing service or maintenance operation on unit turn off and lock off main power switch to unit. Electrical shock can cause personal injury and death. Shut off all power to this equipment during installation and service. The unit may have an internal non-fused disconnect or a field-installed disconnect. **Note that the unit may also be equipped with a convenience outlet, if the outlet is wired to the line side of the unit-mounted disconnect (if equipped), or directly to the units incoming power, it will remain hot when the disconnect in the unit is off. There is a separate fuse/disconnect for the convenience outlet.**

⚠ CAUTION

This unit uses a microprocessor-based electronic control system. **Do not** use jumpers or other tools to short out components or to bypass or otherwise depart from recommended procedures. Any short-to-ground of the control board or accompanying wiring may destroy the electronic modules or electrical components.

⚠ WARNING

1. Improper installation, adjustment, alteration, service, or maintenance can cause property damage, personal injury, or loss of life. Refer to the User’s Information Manual provided with this unit for more details.
2. Do not store or use gasoline or other flammable vapors and liquids in the vicinity of this or any other appliance.

What to do if you smell gas:

1. DO NOT try to light any appliance.
2. DO NOT touch any electrical switch, or use any phone in your building.
3. IMMEDIATELY call your gas supplier from a neighbor’s phone. Follow the gas supplier’s instructions.

If you cannot reach your gas supplier call the fire department.

⚠ WARNING

DO NOT USE TORCH to remove any component. System contains oil and refrigerant under pressure.

To remove a component, wear protective gloves and goggles and proceed as follows:

- a. Shut off electrical power to unit.
- b. Recover refrigerant to relieve all pressure from system using both high-pressure and low pressure ports.
- c. Traces of vapor should be displaced with nitrogen and the work area should be well ventilated. Refrigerant in contact with an open flame produces toxic gases.
- d. Cut component connection tubing with tubing cutter and remove component from unit. Use a pan to catch any oil that may come out of the lines and as a gage for how much oil to add to the system.
- e. Carefully unsweat remaining tubing stubs when necessary. Oil can ignite when exposed to torch flame.

Failure to follow these procedures may result in personal injury or death.

⚠ CAUTION

DO NOT re-use compressor oil or any oil that has been exposed to the atmosphere. Dispose of oil per local codes and regulations. DO NOT leave refrigerant system open to air any longer than the actual time required to service the equipment. Seal circuits being serviced and charge with dry nitrogen to prevent oil contamination when timely repairs cannot be completed. Failure to follow these procedures may result in damage to equipment.

A2L REFRIGERANT CONSIDERATIONS

This equipment is supplied with R-454B, which is a low global warming potential, A2L refrigerant. All A2L refrigerants are considered “mildly flammable”, and extra precaution is required during installation and service.

Work Area

Before any service or installation to this equipment is performed, the immediate area around the equipment should be checked for any potential ignition sources. Any risks of ignition should be minimized or contained before work begins. Additionally, the area around the unit should be checked for the presence or concentrations of flammable refrigerant. All service staff around the unit must be instructed on the nature of the work being carried out. Work in confined spaces shall be avoided.

Ensure that the area is in the open or that it is adequately ventilated before breaking into the system or conducting any hot work. A degree of ventilation shall continue during the period that the work is carried out. The ventilation should safely disperse any released refrigerant and preferably expel it externally into the atmosphere.

Leak Detection

⚠ CAUTION

LEAK DETECTION SYSTEM installed. Unit must be powered at all times except for service.

This equipment is equipped from the factory with two leak detection sensors located in the compressor section, and next to the evaporator coil. These sensors will automatically shut down all ignition sources if the LFL (Lower Flammability Limit) is detected by either or both sensors, while keeping the supply fan active to

provide circulation airflow in accordance with UL 60335-2-40. The supply fan and exhaust fan (if equipped) will remain in circulation mode for five minutes after leak detection sensor has cleared the alarm below the concentration setpoint. Unit must be powered at all times except for service.

In the event of a leak detection sensor lockout, extra caution should be taken when approaching the unit, and opening any service access doors. Hand-held leak detection equipment should be utilized to evaluate the area around the unit for concentrations of refrigerant prior to any service work.

CAUTION
Should a leak detection sensor fail for any reason, it should only be replaced with a factory provided service part. Non-factory sensors should never be utilized in this equipment for any reason.

Verify functionality of leak detection sensors by disconnecting the harness plug located at the bottom of the leak detection sensor and ensuring that all sequences mentioned above take place.

The following leak detection methods are deemed acceptable for all refrigerant systems.

- Electronic leak detectors may be used to detect refrigerant leaks but, in the case of FLAMMABLE REFRIGERANTS, the sensitivity may not be adequate, or may need re-calibration. (Detection equipment shall be calibrated in a refrigerant-free area.)
- Ensure that the detector is not a potential source of ignition and is suitable for the refrigerant used.
- Leak detection equipment shall be set at a percentage of the LFL of the refrigerant and shall be calibrated to the refrigerant employed, and the appropriate percentage of gas (25% maximum) is confirmed.
- Leak detection fluids are also suitable for use with most refrigerants but the use of detergents containing chlorine shall be avoided as the chlorine may react with the refrigerant and corrode the copper pipework.
 - Under no circumstances shall potential sources of ignition be used in the searching for or detection of refrigerant leaks.
 - A halide torch (or any other detector using a naked flame) shall not be used.

A2L Refrigerant Leak Detection System Interlock

Certain applications may require interlocking the DOAS system to field devices that will need to open when the unit initiates A2L dissipation mode. Examples of these devices but not limited to are:

- Fire Dampers
- VAV Dampers

If the DOAS supply air ductwork is connected to the return or OA intake of a separate RTU or other HVAC system, the RTU or other HVAC system will need to be enabled.

When one or both A2L refrigerant leak sensors (A2LGS1 or A2LGS2 sensors) are activated due to a leak, the NO contact in the A2LR will close, therefore initiating A2L dissipation mode. Unit will automatically shut down and remove high-voltage power to major components. The supply fan and exhaust fan (if equipped) will continue running. See Fig. 1 for A2L input wiring. See Fig. 2 for relay wiring.

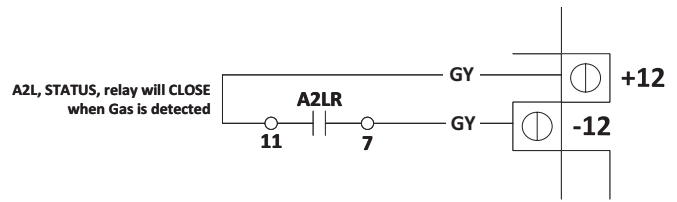

Fig. 1 — Unit Controller A2LR Input

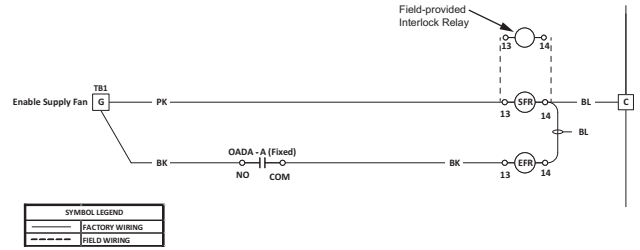

Fig. 2 — Field-provided A2L Interlock Relay Wiring

Unit Charge

All equipment is shipped from the factory pre-charged with refrigerant. Information related to the amount of charge present in each circuit of the unit is found on the unit data plate located either on the condenser section next to the control access door, or inside the control section bulkhead.

WARNING
This unit contains HFC (R-454B), an azeotropic mixture of R-32 (Difluoromethane) and R-1234YF (Tetrafluoropropane). DO NOT VENT R-454B to the atmosphere. The U. S. Clean Air Act requires the recovery of any residual refrigerant. Do not use service equipment or components that are not rated for R-454B equipped systems. R-454B may be odorless.

WARNING
This unit contains HFC (R-454B), which is classified as an A2L refrigerant. The refrigerant is classified as mildly flammable and may ignite in the proper concentrations and with potential ignition sources.

WARNING
Any additional accessories installed within the ductwork connected to this unit must not be a potential ignition source in the event of a refrigerant leak. This includes any item that produces a spark, flame, or has a potential hot surface temperature exceeding 1,290°F (699°C).

WARNING
Do not use means to accelerate the defrosting process or to clean, other than those recommended by the manufacturer.

WARNING
The appliance shall be stored in a room without continuously operating ignition sources (for example: open flames, an operating gas appliance or an operating electric heater).

⚠ WARNING

RISK OF FIRE: Do not pierce or have open flames near the refrigerant system. Failure to follow these procedures may result in personal injury or death.

⚠ WARNING

Be aware that refrigerants may not contain an odor. Exposure can cause serious harm or health conditions.

⚠ WARNING

REFRIGERANT SENSORS for REFRIGERANT DETECTION SYSTEMS shall only be replaced with sensors specified by the appliance manufacture.

Checks to Electrical Devices

Repair and maintenance to electrical components shall include initial safety checks and component inspection procedures. If a fault exists that could compromise safety, then no electrical supply shall be connected to the circuit until it is satisfactorily dealt with. If the fault cannot be corrected immediately but it is necessary to continue operation, an adequate temporary solution shall be used. This shall be reported to the owner of the equipment so all parties are advised.

Initial safety checks shall include:

1. Capacitors are discharged: this shall be done in a safe manner to avoid possibility of sparking.
2. That no live electrical components and wiring are exposed while charging, recovering, or purging the system.
3. That there is continuity of earth bonding.

Check that cabling will not be subject to wear, corrosion, excessive pressure, vibration, sharp edges or any other adverse environmental effects. The check shall also take into account the effects of aging or continual vibration from sources such as compressors or fans.

⚠ WARNING

A flame-producing device may be installed in the same space if the device is provided with an effective flame arrest.

⚠ WARNING

For appliances using A2L REFRIGERANTS connected via an air duct system to one or more rooms, only auxiliary devices approved by the appliance manufacturer or declared suitable with the refrigerant shall be installed in connecting ductwork.

Auxiliary devices must be approved by manufacturer before installation.

GENERAL

This book contains the Controls, Operation and Start-Up information for the Carrier 62W dedicated outdoor air units with Design Series (Revision K) controls. Use this guide in conjunction with the Installation, Start-Up, and Maintenance instructions that are packaged with the unit. Refer to the unit wiring diagrams, located inside the unit control cabinet, for detailed wiring information. See Fig. 3 and Tables 1-3 for unit model number nomenclature.

A factory-installed Equipment Touch™ device (Equipment Touch Device or Equipment Touch App and Field Assistant) is required to configure, modify, and diagnose many of the unit control functions. At least one user interface is recommended per job site.

The 62W unit is a packaged heating, ventilation, and air conditioning (HVAC) unit that specializes in conditioning and supplying 100% outdoor air, also known as dedicated outdoor air system (DOAS). The 62W unit is a packaged, air cooled unit with direct expansion (DX) cooling and optional heating.

The 62W unit is typically utilized as part of make-up air or ventilation systems to provide “neutral air” or air that is supplied near the space dry-bulb temperature, but with relative humidity below 60%. This allows the DOAS unit to handle the latent load of the outdoor air and potentially the space, while leaving remaining space sensible load for ancillary cooling/heating devices. In certain configurations, the DOAS unit may be set up to offset some space sensible loads, allowing it to act as a stage of cooling, but not completely replacing an ancillary device. See the DOAS Application Guide in the 62W product data for further application guidance.

Airflow Process

Outdoor air enters 62W units through the outdoor air intake hood. The outdoor air passes through a filtration device and is conditioned using direct expansion (DX) cooling (with optional liquid subcooling and/or hot gas reheat) or direct expansion (DX) heating or optional auxiliary heating (electric, gas, or steam (special order)/hot water). The conditioned outdoor air is discharged from the supply fan through a vertical or horizontal supply opening. There is no return air opening on 62W Series units with supply only configurations.

For 62W units without the energy recovery system, the outdoor air passes through a filtration device and is conditioned using either direct expansion (DX) cooling (with optional liquid subcooling and/or hot gas reheat), direct expansion (DX) heating or optional auxiliary heating (electric, gas, or steam (special order)/hot water). The conditioned outdoor air is discharged from the supply fan through a vertical or horizontal supply opening. Air can be returned to the unit through an optional vertical return air opening and can be exhausted from the unit by an optional exhaust fan. There is no recirculation of return air to the space.

For 62W units with the energy recovery ventilator, the outdoor air passes through a filtration device and enters the energy recovery device by transferring energy to or from the return air. The outdoor air is then conditioned using direct expansion (DX) cooling (with optional liquid subcooling and/or hot gas reheat) or direct expansion (DX) heating or optional auxiliary heating (electric, gas, or steam (special order)/hot water). The conditioned outdoor air is discharged from the supply fan through a vertical or horizontal supply opening. Air is returned to the unit through a vertical return air opening and passes through a filtration device (if equipped). The return air passes through the energy recovery wheel, where heat is transferred to or from the supply air, and is exhausted from the unit. There is no recirculation of return air to the space.

Refrigeration System

All Carrier dedicated outdoor air units utilize highly efficient scroll compressors that have been optimally designed for use with Puron Advance™ refrigerant (R-454B). All 62W units will have a variable capacity compressor on the lead circuit, which is inverter driven (3+ tons). Inverter driven compressors shall be capable of modulating from 58-100% of nominal compressor capacity. All circuits with inverter compressors shall be equipped with minimum load control valve.

A TXV (thermostatic expansion valve) metering device is used on all systems.

The refrigeration system includes a hot gas bypass valve with all standard scroll compressors and with inverter driven compressors.

EVAPORATOR (INDOOR COIL)

The 62W Series units utilize a 6-row aluminum/copper evaporator coil, with 12 fins per inch. Evaporator coils are available with optional harsh environment coating.

CONDENSER (OUTDOOR COIL)

The 62W Series units utilize a coaxial (tube in tube) condenser coil, with Copper or Cupronickel inner tube and steel outer tube. Condenser coils are not available with optional harsh environment coating. For applications with corrosive environments, the cupronickel (CuNi) coil option is recommended. All 62W units are equipped with one factory installed water regulator valve per refrigerant circuit for head pressure control.

REHEAT SYSTEM

The 62W Series units are standard with modulating hot gas reheat (HGRH) with an optional liquid subcooling. The HGRH system consists of a full faced coil that is fed hot refrigerant gas by lead circuit or by all circuits. The HGRH is a modulating type control.

The liquid subcooling and HGRH system features two full faced coils. The first coil is used for liquid subcooling, and is fed warm liquid gas by all available circuits. The liquid subcooling coil uses cycling (on/off) type control. The second coil is used for HGRH, and is fed hot refrigerant gas by the lead circuit. The HGRH is a modulating type control. Liquid subcooling or HGRH coils are available with optional harsh environment coating.

Heating System

The 62W Series units are available with optional electric, gas, hot water, or steam heating (special order).

DX HEAT PUMP

The standard DX heat pump system consists of a factory-installed highly efficient scroll compressors, a reversing valve per circuit, an Indoor Coil and Outdoor coils. DX heating is the default heat source for the 62W. The other optional AUX heat sources (Gas, Electric or Hot Water) may be enabled to supplement the DX Heating system.

GAS HEAT

The optional gas heating system consists of a factory-installed natural gas or liquefied petroleum (LP) heat insert with tubular, stainless steel heat exchangers and in-shot burners. All heaters are 81% efficient (at sea level) and are available in multiple input ratings, ranging from 75 to 1200 MBtuh. The heater can utilize either a 2-stage, 4-stage, or modulating gas control valve. Modulating valves can be 5:1 (20 to 100%) or 10:1 (10 to 100%) turn-down. Heat exchangers are available with optional harsh environment coating. The gas heater is natural gas or can have LP factory-installed.

ELECTRIC HEAT

The optional electric heating system consists of a factory-installed electric heat insert with low watt density coiled heating elements and stainless steel terminals. The electric heater is available in multiple output ratings, ranging from 5 to 120 kW (at 230/460V) or 3.8 to 90 kW (at 208V). The heater control is accomplished by staging (1, 2, or 4 stages) or by modulation silicon controlled rectifier (SCR).

HOT WATER HEAT

The optional hot water heating system consists of a factory-installed, four-row hot water coil. The hot water control valve must be field provided and installed. The hot water coil is available with optional harsh environmental coating.

62W – Dedicated Outdoor Air Unit^a

Cabinet, Supply, Discharge

- B – 100% OA WSHP / Cabinet B / Vertical Supply / No Exhaust
- C – 100% OA WSHP / Cabinet C / Vertical Supply / No Exhaust
- D – 100% OA WSHP / Cabinet D / Vertical Supply / No Exhaust
- F – 100% OA WSHP / Cabinet B / Horizontal Supply / No Exhaust
- G – 100% OA WSHP / Cabinet C / Horizontal Supply / No Exhaust
- H – 100% OA WSHP / Cabinet D / Horizontal Supply / No Exhaust
- K – 100% OA WSHP / Cabinet B / Vertical Supply / Vertical Exhaust
- L – 100% OA WSHP / Cabinet CL / Vertical Supply / Vertical Exhaust
- M – 100% OA WSHP / Cabinet C / Vertical Supply / Vertical Exhaust
- N – 100% OA WSHP / Cabinet D / Vertical Supply / Vertical Exhaust
- Q – 100% OA WSHP / Cabinet B / Horizontal Supply / Vertical Exhaust
- R – 100% OA WSHP / Cabinet C / Horizontal Supply / Vertical Exhaust
- S – 100% OA WSHP / Cabinet D / Horizontal Supply / Vertical Exhaust
- U – 100% OA WSHP / Cabinet CXL / Vertical Supply / No Exhaust
- V – 100% OA WSHP / Cabinet DXL / Vertical Supply / No Exhaust
- X – 100% OA WSHP / Cabinet CXL / Horizontal Supply / No Exhaust
- Y – 100% OA WSHP / Cabinet DXL / Horizontal Supply / No Exhaust
- 2 – 100% OA WSHP / Cabinet CXL / Vertical Supply / Vertical Exhaust
- 3 – 100% OA WSHP / Cabinet DXL / Vertical Supply / Vertical Exhaust
- 5 – 100% OA WSHP / Cabinet CXL / Horizontal Supply / Vertical Exhaust
- 6 – 100% OA WSHP / Cabinet DXL / Horizontal Supply / Vertical Exhaust
- 7 – 100% OA WSHP / Cabinet CL / Vertical Supply / No Exhaust
- 8 – 100% OA WSHP / Cabinet CL / Horizontal Supply / No Exhaust
- 9 – 100% OA WSHP / Cabinet CL / Horizontal Supply / Vertical Exhaust

Unit Size – Nominal Capacity (MBH)

03 – 36	12 – 150	40 – 480
04 – 48	15 – 180	45 – 540
05 – 60	18 – 210	50 – 600
06 – 72	20 – 240	55 – 660
07 – 84	25 – 300	
08 – 96	30 – 360	
10 – 120	35 – 420	

Energy Recovery Ventilator (ERV) Wheel

Wheel No.	Diameter (in.)	Thickness (mm)	Bypass
– None			
B – ERC-3022C	30	22	Yes
C – ERC-3628C	36	28	Yes
D – ERC-4136C	41	36	Yes
E – ERC-4646C	46	46	Yes
F – ERC-4650C	46	50	Yes
G – ERC-5262C	52	62	Yes
H – ERC-6488C	64	88	Yes
J – ERC-6495C	64	95	Yes
K – ERC-68100C	68	100	Yes
M – ERC-68110C	68	110	Yes
P – ERC-3022C	30	22	No
Q – ERC-3628C	36	28	No
R – ERC-4136C	41	36	No
S – ERC-4646C	46	46	No
T – ERC-4650C	46	50	No
U – ERC-5262C	52	62	No
V – ERC-6488C	64	88	No
W – ERC-6495C	64	95	No
X – ERC-68100C	68	100	No
Y – ERC-68110C	68	110	No

NOTE(S):

- ^a See latest version of Carrier's Dedicated Outdoor Air Systems Builder program for any size and option restrictions.
- ^b ECM supply and exhaust fan motors are not available in 575-v. See physical data tables for ECM motor availability per cabinet size.
- ^c Standard Temperature rise is 80/100°F for horizontal/vertical supply. High Temperature rise is 130/160°F for horizontal/vertical supply and requires an XL cabinet.

SEE NEXT PAGE
FOR REMAINDER
OF MODEL NUMBER
NOMENCLATURE

Supply Fan Motor Options

- A – 1 HP ODP with VFD
- B – 1-1/2 HP ODP with VFD
- C – 2 HP ODP with VFD
- D – 3 HP ODP with VFD
- E – 5 HP ODP with VFD
- F – 7-1/2 HP ODP with VFD
- G – 10 HP ODP with VFD
- H – 15 HP ODP with VFD
- J – 1 HP TEFC with VFD
- K – 1-1/2 HP TEFC with VFD
- M – 2 HP TEFC with VFD
- N – 3 HP TEFC with VFD
- P – 5 HP TEFC with VFD
- Q – 7-1/2 HP TEFC with VFD
- R – 10 HP TEFC with VFD
- S – 15 HP TEFC with VFD
- T – ECM^b
- U – Dual ECM^b

Coil and Reheat Options

Evaporator Coil Rows	HGRH	HGRH Circuit	Sub-Cooling	Condenser Fans
J – 6	Mod	Lead	—	Var Speed
K – 6	Mod	Dual	—	Var Speed
M – 6	Mod	Lead	SubCooling	Var Speed

Heat Options

– None	MBtuh input	Temperature Rise ^c	E-Heat kW
– None			
A – 75		Standard	N/A
B – 100		Standard	N/A
C – 150		Standard	N/A
D – 200		Standard	N/A
E – 250		Standard	N/A
F – 300		Standard	N/A
G – 350		Standard	N/A
H – 400		Standard	N/A
K – 400		High (XL)	N/A
L – 500		High (XL)	N/A
M – 600		High (XL)	N/A
N – 700		High (XL)	N/A
O – 800		High (XL)	N/A
P – 1000		High (XL)	N/A
Q – 1200		High (XL)	N/A
S – N/A		N/A	5
T – N/A		N/A	10
U – N/A		N/A	15
V – N/A		N/A	20
W – N/A		N/A	25
X – N/A		N/A	30
Y – N/A		N/A	35
Z – N/A		N/A	40
1 – N/A		N/A	50
2 – N/A		N/A	60
3 – N/A		N/A	70
4 – N/A		N/A	80
5 – N/A		N/A	100
6 – N/A		N/A	110
7 – N/A		N/A	120
8 – Hot Water Coil			

Fig. 3 – 62W Model Number Information

SEE PREVIOUS PAGE
FOR REMAINDER
OF MODEL NUMBER
NOMENCLATURE

Control Options and Filters

Control Option	Filter Thickness	MERV
- - None	2 in.	MERV 8
A - None	4 in.	MERV 8
B - None	4 in.	MERV 11
C - None	4 in.	MERV 13
D - Smoke detector	2 in.	MERV 8
E - Smoke detector	4 in.	MERV 8
F - Smoke detector	4 in.	MERV 11
G - Smoke detector	4 in.	MERV 13

Voltage Options, Compressor and Condenser Fans

Voltage	Compressor	Condenser Type
A - 208-3-60	VCC Lead Circuit	Copper
C - 208-3-60	VCC Lead Circuit	CuNi
E - 230-3-60	VCC Lead Circuit	Copper
G - 230-3-60	VCC Lead Circuit	CuNi
J - 460-3-60	VCC Lead Circuit	Copper
M - 460-3-60	VCC Lead Circuit	CuNi
P - 575-3-60	VCC Lead Circuit	Copper
R - 575-3-60	VCC Lead Circuit	CuNi

Design Series

K - Revision K Controls

NOTE(S):

- ^a See latest version of Carrier's Dedicated Outdoor Air Systems Builder program for any size and option restrictions.
- ^b ECM supply and exhaust fan motors are not available in 575-v. See physical data tables for ECM motor availability per cabinet size.
- ^c Standard Temperature rise is 80/100°F for horizontal/vertical supply. High Temperature rise is 130/160°F for horizontal/vertical supply and requires an XL cabinet.

Factory Installed Options
Refer to tables on page 9 for available options codes.

Exhaust Fan

- - None	J - 18 in., BI
2 - 350 mm, BI	K - 20 in., BI
4 - 450 mm (High), BI	M - 22 in., BI
5 - 500 mm (Low), BI	N - 25 in., BI
6 - 500 mm (High) 460V only, BI	P - 12 in., AF
7 - 560 mm 208,230V only, BI	Q - 14 in., AF
D - 10 in., BI	R - 16 in., AF
E - 11 in., BI	S - 18 in., AF
F - 12 in., BI	T - 20 in., AF
G - 14 in., BI	U - 22 in., AF
H - 16 in., BI	V - 25 in., AF

Power Exhaust Fan Motor Options

- - None
- A - 1 HP ODP with VFD
- B - 1 1/2 HP ODP with VFD
- C - 2 HP ODP with VFD
- D - 3 HP ODP with VFD
- E - 5 HP ODP with VFD
- F - 7 1/2 HP ODP with VFD
- G - 10 HP ODP with VFD
- H - 15 HP ODP with VFD
- J - 1 HP TEFC with VFD
- K - 1 1/2 HP TEFC with VFD
- M - 2 HP TEFC with VFD
- N - 3 HP TEFC with VFD
- P - 5 HP TEFC with VFD
- Q - 7 1/2 HP TEFC with VFD
- R - 10 HP TEFC with VFD
- S - 15 HP TEFC with VFD
- T - ECM^b
- U - Dual ECM^b

Supply Fan

2 - 350 mm, BI	J - 18 in., BI
4 - 450 mm (High), BI	K - 20 in., BI
5 - 500 mm (Low), BI	M - 22 in., BI
6 - 500 mm (High) 460V only, BI	N - 25 in., BI
7 - 560 mm 208,230V only, BI	P - 12 in., AF
D - 10 in., BI	Q - 14 in., AF
E - 11 in., BI	R - 16 in., AF
F - 12 in., BI	S - 18 in., AF
G - 14 in., BI	T - 20 in., AF
H - 16 in., BI	U - 22 in., AF
	V - 25 in., AF

LEGEND

- AF** - Airfoil
- BI** - Backward Inclined
- ECM** - Electronically Commutated Motor
- N/A** - Not Applicable
- ODP** - Open Drip Proof
- TEFC** - Totally Enclosed Fan Cooled
- VCC** - Variable Capacity Compressor
- VFD** - Variable Frequency Drive

Fig. 3 - 62W Model Number Information (cont)

Table 1 – FIOP Table

OPTION	DESCRIPTION
1	Air flow monitor control (supply only or supply and exhaust)
2	Spring type vibration isolation on Supply fan and Exhaust Fan (if exhaust fan selected)
3	Non-fused disconnect
4	Pressure control (supply duct pressure, exhaust space pressure)
5	115V GFI Convenience outlet w/15A breaker - Unit-Powered Type
6	5:1 turndown modulating gas heat or SCR controlled electric heat
7	10:1 turndown modulating gas heat
8	ERV VFD Defrost
9	Harsh environment coating- cabinet, evap coil, reheat coil, sub-cooling coil (if installed), Hot Water Coil (if installed)

Table 2 – Limitations

OPTION	DESCRIPTION
1	Not available with duct pressure control.
2	Spring vibration isolation not available on ECM.
3	Not applicable.
4	Not available with airflow monitor.
5	Not applicable.
6	5:1 not available on CXL or DXL. SCR not available on 5kW.
7	10:1 Modulating not available on 75MBH.
8	Not applicable.
9	Not available in ODP or ECM motors.

Table 3 – Digits 17 and 18

17 and 18	FIOPs	17 and 18	FIOPs	17 and 18	FIOPs	17 and 18	FIOPs	17 and 18	FIOPs
AA	1	CH	4,7	EP	2,8,9	HM	1,2,5,9	KW	3,4,5,8,9
AB	1,2	CI	5,7	EQ	2,9	HN	3,5,9	KY	2,3,4,5,8,9
AC	2	CJ	7	ER	3,4,5,6,8,9	HO	1,3,5,9	LL	1,2,6
AD	1,2,3	CN	1,5,6,8	ES	3,5,6,8,9	HP	2,3,5,9	LM	1,3,6
AE	2,3	CO	1,6,8	ET	3,6,8,9	HQ	1,2,3,5,9	LN	2,3,6
AF	1,3	CP	1,8	EU	3,8,9	HR	4,5,9	LO	1,2,3,6
AG	3	CQ	2,3,4,5,6,8	EV	3,9	HT	2,4,5,9	LQ	2,4,6
AH	1,3,5	CR	2,4,5,6,8	EW	4,5,6,8,9	HV	3,4,5,9	LS	3,4,6
AJ	2,3,4	CS	2,5,6,8	EX	4,6,8,9	HX	2,3,4,5,9	LU	2,3,4,6
AL	2,4	CT	2,6,8	EY	4,8,9	HZ	1,2,8	LW	5,6
AM	3,4	CU	2,8	EZ	4,9	II	1,3,8	LX	1,2,5,6
AN	4	CV	3,4,5,6,8	FF	5,6,8,9	IJ	2,3,8	LY	1,3,5,6
AS	1,5	CW	3,5,6,8	FG	5,8,9	IK	1,2,3,8	LZ	2,3,5,6
AT	2,3,4,5	CX	3,6,8	FH	5,9	IM	2,4,8	MM	1,2,3,5,6
AU	2,3,5	CY	3,8	FI	6,8,9	IO	3,4,8	MW	1,6,9
AV	2,4,5	CZ	4,5,6,8	FJ	6,9	IQ	2,3,4,8	MX	2,6,9
AW	2,5	DD	4,6,8	FK	8,9	IS	1,5,8	MY	1,2,6,9
AX	3,4,5	DE	4,8	FL	9	IT	2,5,8	MZ	3,6,9
AZ	3,5	DF	5,6,8	FP	1,5,7,8,9	IU	1,2,5,8	NN	1,3,6,9
BB	4,5	DG	5,8	FQ	1,7,8,9	IV	3,5,8	NO	2,3,6,9
BC	5	DH	6,8	FS	2,3,4,5,7,8,9	IW	1,3,5,8	NP	1,2,3,6,9
BG	1,5,6	DI	8	FT	2,4,5,7,8,9	IX	2,3,5,8	NQ	4,6,9
BH	1,6	DM	1,5,7,8	FU	2,5,7,8,9	IY	1,2,3,5,8	NS	2,4,6,9
BI	2,3,4,5,6	DN	1,7,8	FV	2,7,8,9	IZ	4,5,8	NU	3,4,6,9
BJ	2,4,5,6	DO	2,3,4,5,7,8	FX	3,4,5,7,8,9	JK	2,4,5,8	NW	2,3,4,6,9
BK	2,5,6	DP	2,4,5,7,8	FY	3,5,7,8,9	JM	3,4,5,8	NY	5,6,9
BL	2,6	DQ	2,5,7,8	FZ	3,7,8,9	JO	2,3,4,5,8	NZ	1,5,6,9
BM	3,4,5,6	DR	2,7,8	GH	4,5,7,8,9	JQ	1,2,8,9	OO	2,5,6,9
BN	3,5,6	DS	3,4,5,7,8	GI	4,7,8,9	JR	1,3,8,9	OP	1,2,5,6,9
BO	3,6	DT	3,5,7,8	GK	5,7,8,9	JS	2,3,8,9	OQ	3,5,6,9
BP	4,5,6	DU	3,7,8	GM	7,8,9	JT	1,2,3,8,9	OR	1,3,5,6,9
BQ	4,6	DV	4,5,7,8	GN	7,9	JV	2,4,8,9	OS	2,3,5,6,9
BR	6	DX	4,7,8	GP	1,2,5	JX	3,4,8,9	OT	1,2,3,5,6,9
BV	1,5,7	DY	5,7,8	GQ	1,2,3,5	JZ	2,3,4,8,9	OU	4,5,6,9
BW	1,7	DZ	7,8	GS	1,2,9	KL	1,5,8,9	OW	2,4,5,6,9
BX	2,3,4,5,7	EH	1,5,6,8,9	GT	1,3,9	KM	2,5,8,9	OY	3,4,5,6,9
BY	2,4,5,7	EI	1,6,8,9	GU	2,3,9	KN	1,2,5,8,9	PP	2,3,4,5,6,9
BZ	2,5,7	EJ	1,8,9	GV	1,2,3,9	KO	3,5,8,9	PR	1,2,6,8
CC	2,7	EK	1,9	GX	2,4,9	KP	1,3,5,8,9	PS	1,3,6,8
CD	3,4,5,7	EL	2,3,4,5,6,8,9	GZ	3,4,9	KQ	2,3,5,8,9	PT	2,3,6,8
CE	3,5,7	EM	2,4,5,6,8,9	HI	2,3,4,9	KR	1,2,3,5,8,9	PU	1,2,3,6,8
CF	3,7	EN	2,5,6,8,9	HK	1,5,9	KS	4,5,8,9	PW	2,4,6,8
CG	4,5,7	EO	2,6,8,9	HL	2,5,9	KU	2,4,5,8,9	PY	3,4,6,8

Table 3 — Digits 17 and 18 (cont)

17 and 18	FIOPs	17 and 18	FIOPs	17 and 18	FIOPs	17 and 18	FIOPs
QQ	2,3,4,6,8	SZ	1,2,3,7	YA	2,3,4,7,9	YZ	3,4,7,8
QS	1,2,5,6,8	TU	2,4,7	YC	5,7,9	ZB	2,3,4,7,8
QT	1,3,5,6,8	TW	3,4,7	YD	1,5,7,9	ZD	1,2,5,7,8
QU	2,3,5,6,8	TY	2,3,4,7	YE	2,5,7,9	ZE	1,3,5,7,8
QV	1,2,3,5,6,8	UU	1,2,5,7	YF	1,2,5,7,9	ZF	2,3,5,7,8
QX	1,2,6,8,9	UV	1,3,5,7	YG	3,5,7,9	ZG	1,2,3,5,7,8
QY	1,3,6,8,9	UW	2,3,5,7	YH	1,3,5,7,9	ZI	1,2,7,8,9
QZ	2,3,6,8,9	UX	1,2,3,5,7	YI	2,3,5,7,9	ZJ	1,3,7,8,9
RR	1,2,3,6,8,9	UZ	1,7,9	YJ	1,2,3,5,7,9	ZK	2,3,7,8,9
RV	3,4,6,8,9	VV	2,7,9	YK	4,5,7,9	ZL	1,2,3,7,8,9
RX	2,3,4,6,8,9	VW	1,2,7,9	YM	2,4,5,7,9	ZO	2,4,7,8,9
RZ	1,2,5,6,8,9	VX	3,7,9	YO	3,4,5,7,9	ZQ	3,4,7,8,9
SS	1,3,5,6,8,9	VY	1,3,7,9	YQ	2,3,4,5,7,9	ZS	2,3,4,7,8,9
ST	2,3,5,6,8,9	VZ	2,3,7,9	YS	1,2,7,8	ZU	1,2,5,7,8,9
SU	1,2,3,5,6,8,9	WW	1,2,3,7,9	YT	1,3,7,8	ZV	1,3,5,7,8,9
SW	1,2,7	WX	4,7,9	YU	2,3,7,8	ZW	2,3,5,7,8,9
SX	1,3,7	WZ	2,4,7,9	YV	1,2,3,7,8	ZX	1,2,3,5,7,8,9
SY	2,3,7	XY	3,4,7,9	YX	2,4,7,8	ZZ	—

Filtration System

The 62W Series units are equipped with either a 2-in. (MERV 8 pleated) filter or a 4-in. (MERV 8, 11 or 13 pleated) filter (located before the DX coil). A metal mesh screen is used on the outdoor air intake to prevent larger debris from entering the unit. For units equipped with the optional energy recovery ventilator (ERV), 2-in. MERV 8 pleated filters are located on the outdoor air and return air entrances of the wheel.

Energy Recovery Ventilator

The 62W units are available with an optional belt driven, rotary energy recovery ventilator (ERV). The ERV can have multiple diameters and thicknesses. The ERVs include VFD defrost and are available with optional wheel bypass.

Exhaust Fan

The 62W units with a return exhaust configuration are available with an optional factory-installed direct drive exhaust fan. Exhaust fans can be airfoil (AF) or backward inclined (BI) type and are available in multiple fan sizes. Exhaust fans are available with optional harsh environment coating. Fan motors range from 1/2 to 15 hp and are available in open drip proof (ODP), totally enclosed fan cooled (TEFC), or electronically commutated motors (ECM). TEFC and ODP motors have a factory-installed VFD as standard.

Supply Fan

All 62W units include a factory-installed direct drive supply fan. Supply fans can be airfoil (AF) or backward incline (BI) type and are available in multiple fan sizes. Supply fans are available with optional harsh environment coating. Fan motors range from 1/2 to 15 hp and are available in open drip proof (ODP), totally enclosed fan cooled (TEFC) or electronically commutated motors (ECM). TEFC and ODP motors have a factory-installed VFD as standard.

CONTROLS

Carrier 62W Series units are equipped with an OEMCtrl¹ OptiCORE¹ LS-1628u controller microprocessor-based controller that provides equipment control based on operating conditions and user configuration. The OptiCORE LS-1628u controller can directly control individual components (ex. supply fan, compressors, air damper, HGRH) or can enable optional components for individual control (condenser fans, ERV, etc.). Controller configuration, set point adjustment, status monitoring, and troubleshooting are achieved using a factory-installed Equipment Touch 2

display. See Fig. 4 for typical Equipment Touch wiring connection to unit controller.

NOTE: Equipment Touch 2 controls require external 24VDC power. Do not power the Equipment Touch from the unit controller.

Some of the features of the LS-1628u controller include:

- Easy access to set points, schedules, status, and unit configuration via local or remote interface
- Built-in password protection to prevent unauthorized access
- Built in timer for compressor protection
- Factory configured control program archive
- Service test and diagnostic mode
- Controller mounted on/off switch for easy power cycling
- Fully integrated webpage for easy communication port configuration via SERVICE PORT connection
- Integrated LEDs (light-emitting diodes) to display controller and I/O operation
- eMMC Flash memory back-up to maintain time and date in event of a power outage

NOTE: The OptiCORE controller has a 32-bit ARM Cortex-A8, 600MHz, processor with multi-level cache memory / 16 GBs eMMC Flash memory and 256 MB DDR3 DRAM.

Control Configuration

The OptiCORE controller is preprogrammed and prewired from the factory to reflect the factory configuration and factory installed options for each unit. Any field modifications of the unit must be updated in the unit control configuration.

Controller Ports

The OptiCORE controller has sixteen universal outputs (UO) and twenty-eight universal inputs (UI). All of the input and output (I/O) settings are pre-configured from the factory to reflect the factory unit configuration. A predetermined amount of the controller's I/O are field configurable to the factory configurations. See Fig. 5 for typical controller layout.

UNIVERSAL INPUTS

All universal inputs can be set to read voltage, amperage, resistance (temperature), and discrete contact. All inputs are configured via software (Factory Program.) See Table 4 for typical universal inputs.

1. Third-party trademarks and logos are the property of their respective owners.

NOTE: The universal inputs and analog outputs are pre-configured at the factory for each factory option package for the 62W Series. Inputs UI-2, UI-4, UI-10, and UI-11 are set to read 0 to 10 V. All other UIs are set to read resistance (temperature) and dry contacts. Outputs UO-01, UO-02, UO-04, UO-05, UO-06 and UO-07 are set to output voltage. See Tables 4 and 5 for default controller configuration.

NOTE: Always refer to the units wiring diagram for confirmation of the assigned inputs and outputs for each unit. Each unit may have different I/O's assigned based on configuration, options and date of manufacture.

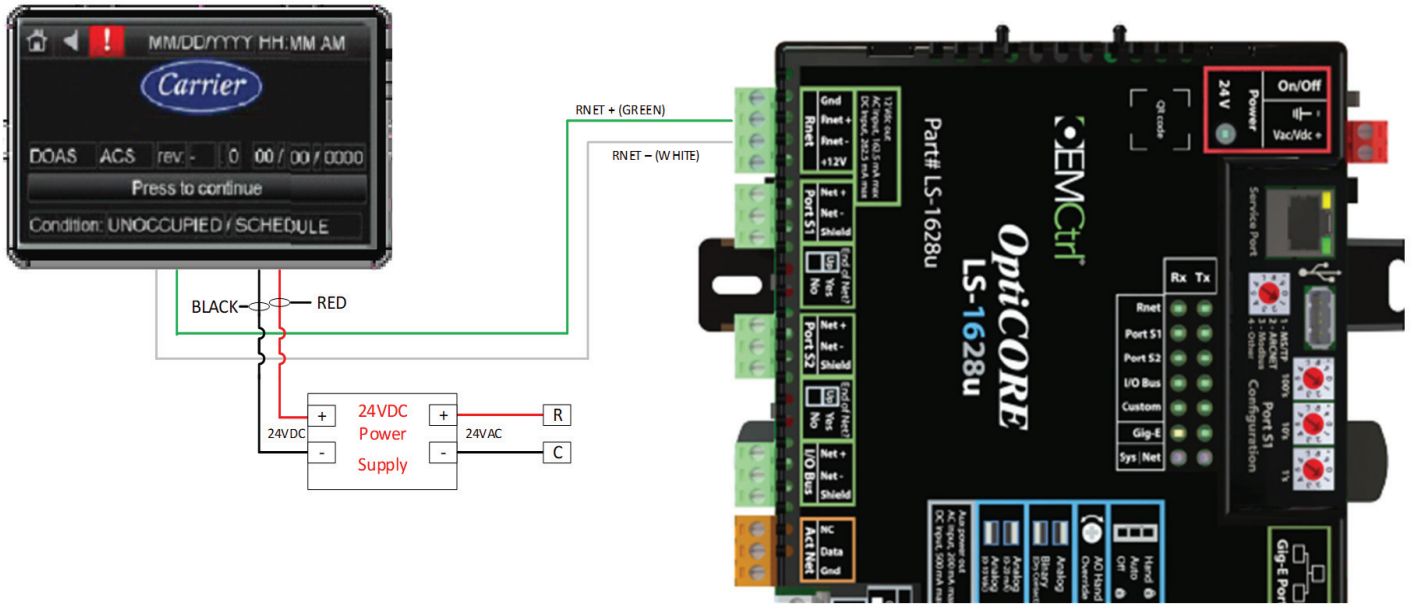

Fig. 4 – Equipment Touch 2 Connection to Unit Controller

Table 4 – Inputs

NUMBER	NAME	SENSOR TYPE	DESCRIPTION
OptiCORE LS-1628u CONTROLLER – UNIVERSAL INPUTS WITH ERV			
UI-01	ECA-T	Thermistor	Entering Coil Air Temperature
UI-02	ECA-RH	0-10 vdc	Entering Coil Relative Humidity
UI-03	SAT	Thermistor	Supply Air Temperature
UI-04	SA-RH	0-10 vdc	Supply Air Relative Humidity
UI-05	OAT	Thermistor	Outside Air Temperature
UI-06	RAT	Thermistor	Return Air Temperature
UI-07	WExAT	Thermistor	Wheel Exhaust Air Temperature
UI-08	DxLAT1	Thermistor	DX Coil Leaving Air Temperature 1
UI-09	DxLAT2	Thermistor	DX Coil Leaving Air Temperature 2
UI-10	SF-DPT or AMS	0-10 vdc	Supply Fan Duct Pressure Transducer or Airflow Monitoring Station
UI-11	ZN-DPT or AMS	0-10 vdc	Zone (Building)/Exhaust Pressure Transducer or Airflow Monitoring Station
UI-12	A2L, STATUS	Normally Open Contact	Relay will close when refrigerant leak is detected
UI-13	OADA-A	Normally Open Contact	Two Position Outdoor Air Damper
UI-14	WM-CS	Normally Open Contact	Wheel Motor Current Sensor
UI-15	EF-CS	Normally Open Contact	Exhaust Fan Current Sensor
UI-16	SF-CS	Normally Open Contact	Supply Fan Current Sensor
UI-17	CC1-CS	Normally Open Contact	Cooling Circuit 1 Current Sensor
UI-18	LPS1	Normally Open Contact	Low Pressure Switch Cooling Circuit 1
UI-19	HPS1	Normally Open Contact	High Pressure Switch Cooling Circuit 1
UI-20	CC2-CS	Normally Open Contact	Cooling Circuit 2 Current Sensor
UI-21	LPS2	Normally Open Contact	Low Pressure Switch Cooling Circuit 2
UI-22	HPS2	Normally Open Contact	High Pressure Switch Cooling Circuit 2
UI-23	FZT	Normally Closed Contact	Condenser Water Freeze Stat
UI-24	WFS	Normally Open Contact	Water Flow Switch
UI-25	CFI	Normally Open Contact	Clogged Filter Indicator
UI-26	COS	Normally Closed Contact	Condensate Overflow Switch
UI-27	EMR	Normally Closed Contact	Energy Management Relay
UI-28	SD	Normally Closed Contact	Smoke Detector

Table 4 – Inputs (cont)

NUMBER	NAME	SENSOR TYPE	DESCRIPTION
OptiCORE LS-1628u CONTROLLER – UNIVERSAL INPUTS WITHOUT ERV			
UI-01	OAT	Thermistor	Outside Air Temperature
UI-02	OA-RH	0-10 vdc	Outside Air Relative Humidity
UI-03	SAT	Thermistor	Supply Air Temperature
UI-04	SA-RH	0-10 vdc	Supply Air Relative Humidity
UI-05	—	—	—
UI-06	—	—	—
UI-07	—	—	—
UI-08	DxLAT1	Thermistor	DX Coil Leaving Air Temperature 1
UI-09	DxLAT2	Thermistor	DX Coil Leaving Air Temperature 2
UI-10	SF-DPT or AFS	0-10 vdc	Supply Fan Duct Pressure Transducer or Airflow Monitoring Station
UI-11	ZN-DPT or AFS	0-10 vdc	Zone / Exhaust Pressure Transducer or Airflow Monitoring Station
UI-12	A2L, STATUS	Normally Open Contact	Relay will close when refrigerant leak is detected
UI-13	OADA-A	Normally Open Contact	Two Position Outdoor Air Damper
UI-14	WM-CS	Normally Open Contact	Wheel Motor Current Sensor
UI-15	EF-CS	Normally Open Contact	Exhaust Fan Current Sensor
UI-16	SF-CS	Normally Open Contact	Supply Fan Current Sensor
UI-17	CC1-CS	Normally Open Contact	Cooling Circuit 1 Current Sensor
UI-18	LPS1	Normally Open Contact	Low Pressure Switch Cooling Circuit 1
UI-19	HPS1	Normally Open Contact	High Pressure Switch Cooling Circuit 1
UI-20	CC2-CS	Normally Open Contact	Cooling Circuit 2 Current Sensor
UI-21	LPS2	Normally Open Contact	Low Pressure Switch Cooling Circuit 2
UI-22	HPS2	Normally Open Contact	High Pressure Switch Cooling Circuit 2
UI-23	FZT	Normally Closed Contact	Condenser Water Freeze Stat
UI-24	WFS	Normally Open Contact	Water Flow Switch
UI-25	CFI	Normally Open Contact	Clogged Filter Indicator
UI-26	COS	Normally Closed Contact	Condensate Overflow Switch
UI-27	EMR	Normally Closed Contact	Energy Management Relay
UI-28	SD	Normally Closed Contact	Smoke Detector

LEGEND

UI — Universal Input
VFD — Variable Frequency Drive

Table 5 – Outputs

NUMBER	NAME	SENSOR TYPE	DESCRIPTION
OptiCORE LS-1628u CONTROLLER – UNIVERSAL OUTPUTS (LEAD CIRCUIT VARIABLE SPEED COMPRESSOR 3-55 TONS)			
UO-01	SF1VFD	0-10 vdc	Supply Fan VFD
UO-02	EF1VFD	0-10 vdc	Exhaust Fan VFD
UO-03	—	—	—
UO-04	MRC (RH)	0-10 vdc	Modulating Reheat Controller
UO-05	WMVFD	0-10 vdc	Wheel Motor VFD
UO-06	Mod. Heat / Staged Heat	0-10 vdc	Modulating / 2nd Stage Heat (Gas, Electric, Hot Water)
UO-07	CM1VFD	0-10 vdc	Lead Circuit Variable speed compressor VFD
UO-08	—	—	—
UO-09	SF/EF Enable / A2L Interlock	Relay/Triac	Supply Fan / Exhaust Fan Enable / A2L Interlock
UO-10	Comp. #1 Enable	Relay/Triac	Compressor 1 Enable
UO-11	Comp. #2 Enable	Relay/Triac	Compressor 2 Enable
UO-12	—	—	—
UO-13	RV Enable	Relay/Triac	Reversing Valve Enable
UO-14	OA Damper Enable	Relay/Triac	Outside Air Damper / ECW Bypass Enable
UO-15	ERV Enable	Relay/Triac	ERV Enable
UO-16	Sub-Cooling Coil Enable	Relay/Triac	Sub-Cooling Coil Enable

LEGEND

UO — Universal Output
VFD — Variable Frequency Drive

Communication

See Fig. 5 and 6 for typical controller configuration.

LOCAL RNET ACCESS PORT

The LS-1628u controller is equipped with a Local Service port and a Local Rnet Access port. Access to modify, configure, and diagnose the controller is achieved by attaching an Equipment Touch 2™ device to the Local Service port. The Local Service port provides communication to the Equipment Touch device. Power to the Equipment Touch 2 is supplied by an external 24VDC power supply. (See Fig. 6.) The Local Rnet Access port supports the Carrier ZS2 space temperature sensor (optional) to monitor space temperature.

BAS COMMUNICATION

The LS-1628u controller Port 2a is configurable for EIA-232 or EIA-485 (2-wire or 4-wire). The controller can be configured for BACnet™1 (MS/TP) with external Building Automation Systems (BAS). See “BAS COMMISSIONING” on page 82 for BAS integration guide.

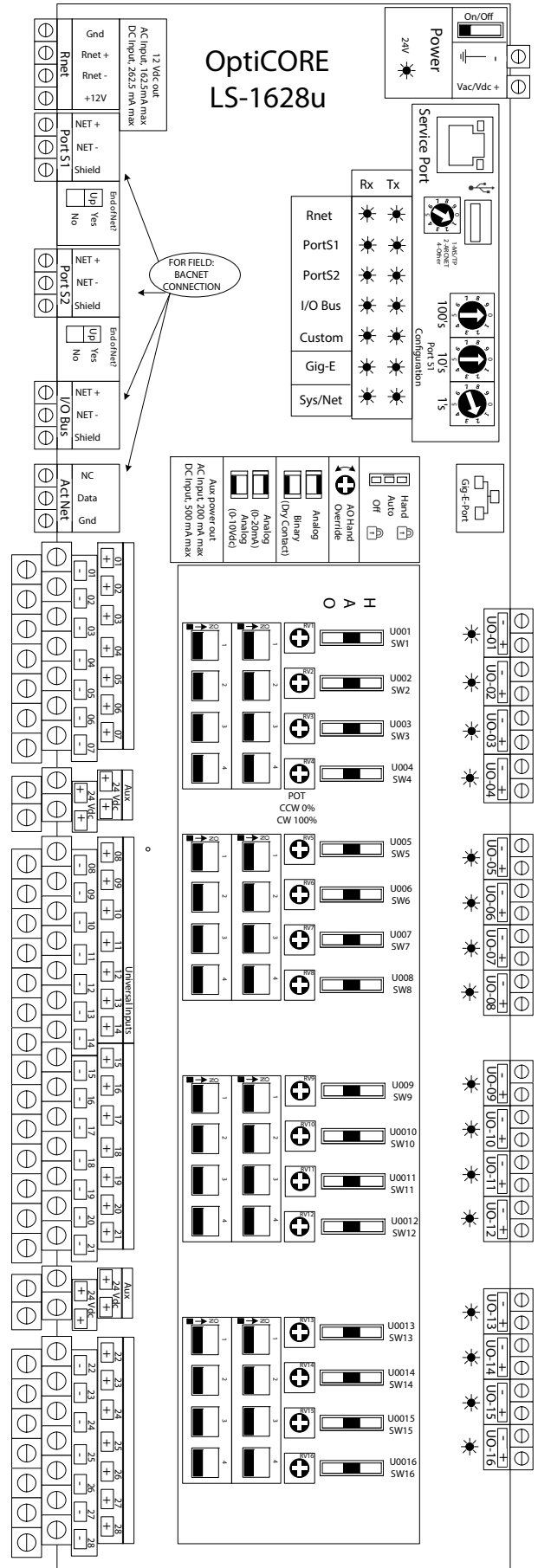

Fig. 5 — Unit Controller

1. Third-party trademarks and logos are the property of their respective owners.

EQUIPMENT TOUCH™ DEVICE

General

The factory installed Equipment Touch is a touchscreen device that you can attach to a controller to view or change its property values, schedule equipment, view trends, and more, without having to access the unit over a building automation system (BAS).

The Equipment Touch is the recommended start-up and user interface for the LS-1628u controller found in all 62W Series units, and can be used to configure, monitor, and control unit operation. The Equipment Touch 2 device features an illuminated, 4.3-in. color pixel touchscreen display and connects to a single open (BACnet) equipment controller. It provides building occupants, facility managers, and installers a powerful user interface for managing a single piece of HVAC equipment. See Fig. 7 for Equipment Touch layout.

The unit is also compatible with the Equipment Touch App and Field Assistant. The Equipment Touch App offers the same interfacing capabilities as the Equipment Touch Device. The App is available in the Google Play Store and is compatible with android devices. Field Assistant is a PC-based program that allows users to view the unit control properties and parameters. Equipment Touch App users will also need the USB link cable (available in the USB Tech Tools Kit, Part Number USB-TKIT) and a micro USB to USB adapter (Equipment Touch App only). Field Assistant users will also need the USB Link Cable and a network cable. Please refer to the Field Assistant guide for further details.

NOTE: Two Equipment Touch devices cannot be used on a single controller simultaneously.

NOTE: The 62W unit is not compatible with System Touch™ device.

NOTE: Revision K 62W units are compatible with the Equipment Touch 2 (P/N: EQT2) and not with the previous version Equipment Touch (P/N: EQT1). The 62W units with Rev. K and newer is also compatible with the EQT 3 in the 7 in. and 10 in. displays. See bulletin 111-22-13 for more information on EQT 3.

Device Connection

The Equipment Touch 2 requires 24VDC power. The 62W unit includes a 24VDC power supply in the control box to power the Equipment Touch 2.

NOTE: Do not power the Equipment Touch 2 from the controller power. The Equipment Touch 2 communication connection is made at the controller service port. See Fig. 6 for Equipment Touch wiring details.

The USB Link cable for Field Assistant can be attached at the local Rnet access port on the LS-1628u controller or on the bottom of the ZS zone temp sensor (if used). See Fig 5 for controller layout.

NOTE: The Equipment Touch 2 device requires the controller to be powered in order to communicate with the controller.

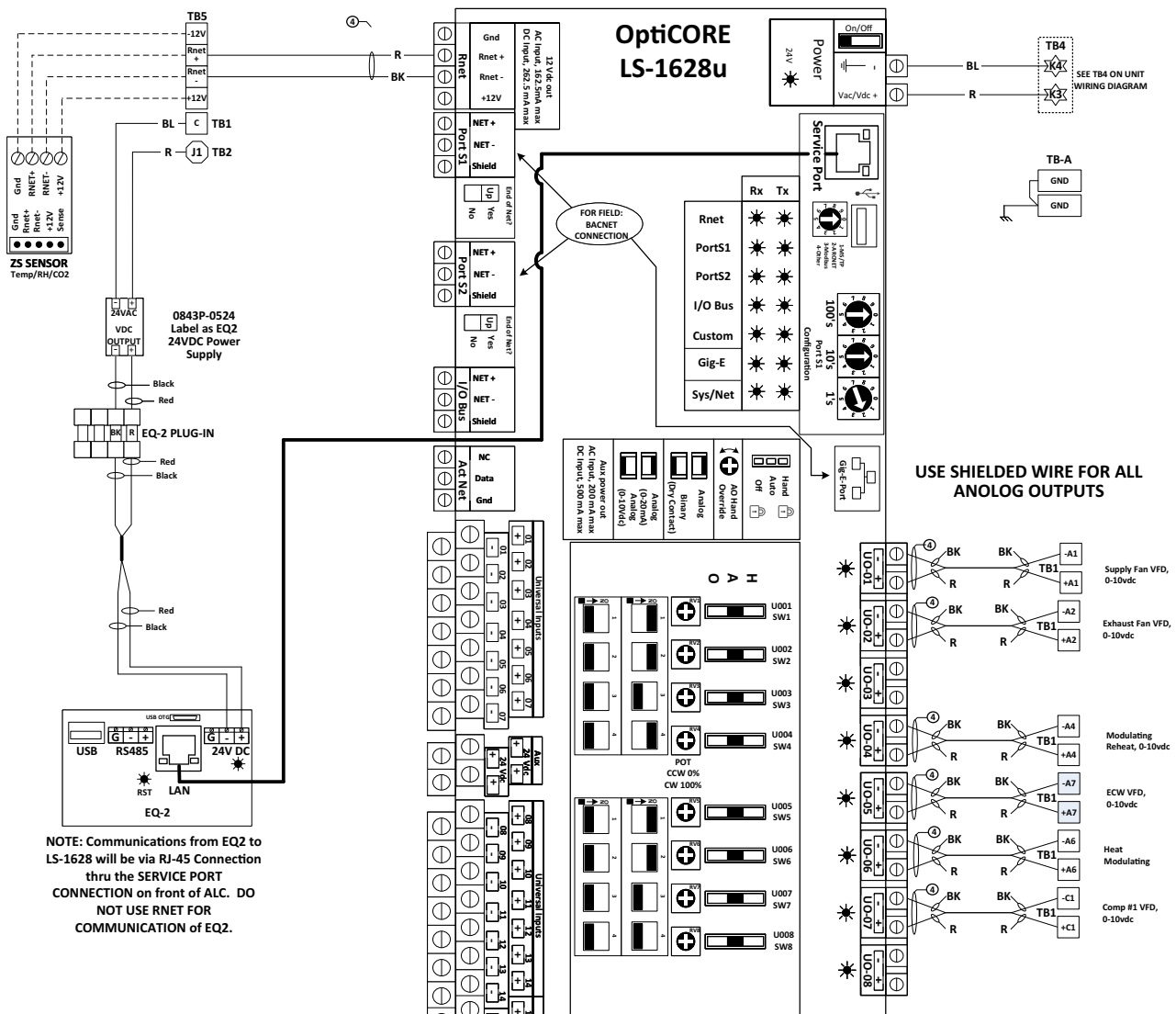

Fig. 6 – Typical Equipment Touch Wiring

Equipment Touch Usage

The Equipment Touch 2 features intuitive operation to make control navigation easy. See Fig. 7. See Table 6 for some tips on using and navigating through screens with the Equipment Touch. More information can be found in the EQT2 TruVu™ ET Display installation and start-up guide.

Access Control

When accessing a screen or trying to edit a setting or set point that may impact unit operation, the keypad will appear, and the user will be required to enter a password to indicate their access level. There are three user levels for accessing the Equipment Touch screens and changing information:

USER (REQUIRES NO PASSWORD)

Has access to only some screens and is not able to change or edit any critical information.

ADMIN (REQUIRES PASSWORD 1111)

Has access to most screens and can change and edit most information. Admin access should allow full start-up and operation of the equipment.

FACTORY (REQUIRES FACTORY PASSWORD)

Has access to all screens and can change and edit all information. Contact Carrier technical support if factory password is needed.



Fig. 7 — Equipment Touch 2

Table 6 — Navigation Buttons

	<p>Home Button</p> <p>Press the home button from any screen to be taken back to the home screen.</p>
	<p>Back Button</p> <p>Press the back button to be taken to the previous screen.</p>
	<p>Alarm Button</p> <p>Press the alarm button to be taken to the alarm screen. If the alarm button is shown in black, no alarms are active. If the alarm button is red, there is an active alarm.</p>
	<p>Link Button</p> <p>Press the link button to be taken to the screen indicated by the link.</p>
	<p>Slider</p> <p>A slider indicates that more information is available on a screen. Use the up or down arrows or drag the location button in the middle to scroll through the screen.</p>
	<p>Drop Down Menu</p> <p>A box with a white border and arrow on the right side indicates that more options are available. Press on the button to see the full option list.</p>
	<p>Non-Editable Field</p> <p>A box with a gray or no border and yellow texts indicates a non-editable field. This value may be a sensor reading or a set point on a status screen. This information may be editable on a different screen or with a different level of access.</p>
	<p>Editable Field</p> <p>A box with white border indicates an editable field. Press inside the box to edit the values in the field.</p>
	<p>Keypad</p> <p>When it is necessary to enter information, such as the login screen or an editable box, the keypad will be displayed. The text shown in white box at the top of the keypad will be entered into the screen. Use the cancel or done buttons on the bottom to exit out of the keypad and delete (cancel) or save (done) the entered value.</p>

CONTROL NAVIGATION

General

When using the Equipment Touch device to interface with the LS-1628u controller, the screens, text, and options displayed will be based upon the unit options and configuration for each unit. For example, if a unit does not have heat, the heating set point, heating status screen, heating PID screen, and heating related alarms will not be displayed. The unit will not perform any heating related tests during test mode.

Standby Screen

Standby screen is displayed when the Equipment Touch has been idle for a preset period. See Fig. 8.

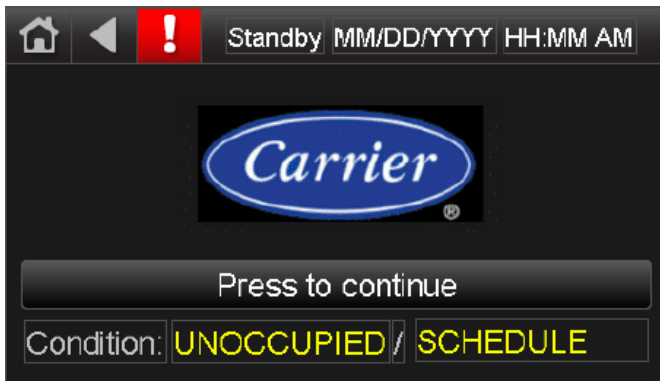

Fig. 8 — Standby Screen

The Standby screen will show the controller date and time (top right corner) and the current operating condition/mode (bottom of screen). Use the press to continue button or back button to exit the Standby screen and open the last screen viewed prior to standby. Use the home button to exit to the home screen.

Home Screen

The Home screen is the main access point to all additional screens and displays the current unit operating mode/condition. The Home screen can be accessed at any time by pressing the Home icon on the top bar. See Fig. 9.

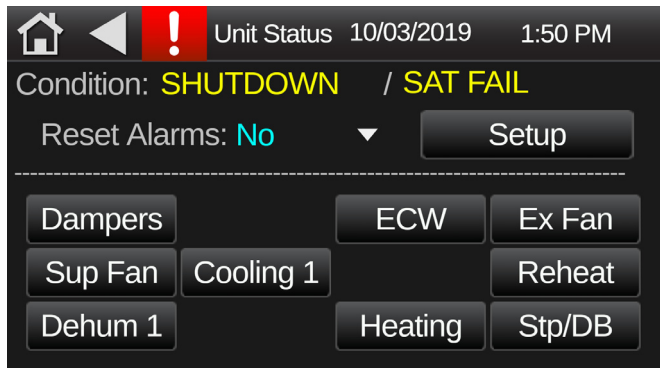

Fig. 9 — Home Screen

When an alarm is active, the top portion of the Home screen will show the Reset Alarm function. To reset all active alarms, click on the down arrow next to “No” and change the value to “Yes”. “Yes” will display for 5 seconds and then change back to “No”. After a 2-minute delay, the Reset Alarm function will disappear if no active alarms exist.

The main portion of the Home screen contains links to status screens for individual components or modes. Pressing any of the component names will bring you to the associated status screen.

The Home screen also contains a link to the Set Point screen (Stp/DB) and the Technical Settings (Set-Up) screen.

Status Screens

Status screens can be accessed from the Home screen and will show relevant information for the listed component or system, such as operating status, modulation status, alarm status, sensor readings, and set points. See Fig. 10.

Status screens do not allow for editing of information and do not require a password to access. The bottom of the status screen may contain links to other related screens, such as related components, set points, or tech settings screens.

Damper Status

The Damper Status screen shows the status of the outdoor air damper and the status of the smoke detector (if equipped) and the energy management or emergency management relay (if configured). See Fig. 10.

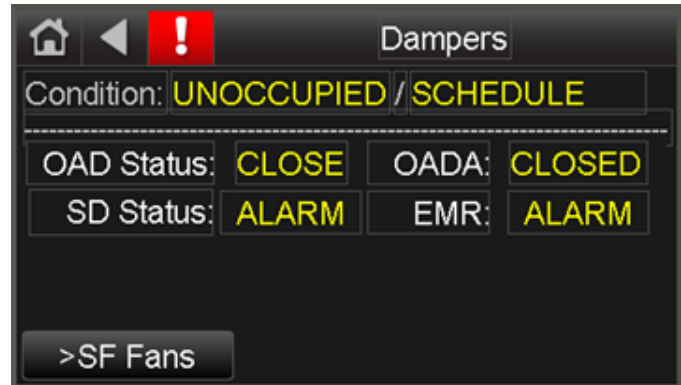

Fig. 10 — Damper Status Screen

The following statuses are available on the Damper status screen:

- OAD Status is the command of the Outside Air Damper (BO6) on the expansion board (CLOSE/OPEN).
- OADA is the status feedback from the OD auxiliary contact (CLOSED/OPENED), the Supply Fan will not start until this status is OPENED.
- SD Status will show either NORMAL (N.C.) or ALARM (N.O.).
- EMR is the status for an Emergency/Energy Management Relay (N.C.), which is field wired to UI-27 of the expander module. The EMR will show as ALARM when the relay is open or NORMAL when the relay is closed. See EMR on the Misc. Options B screen under Unit Control Config (*Home*→*Set Up*→*Unit Config*).

The Supply Fan Status screen shows the status and parameters for the supply fan (SF) and the clogged filter indicator (CFI). See Fig. 11.

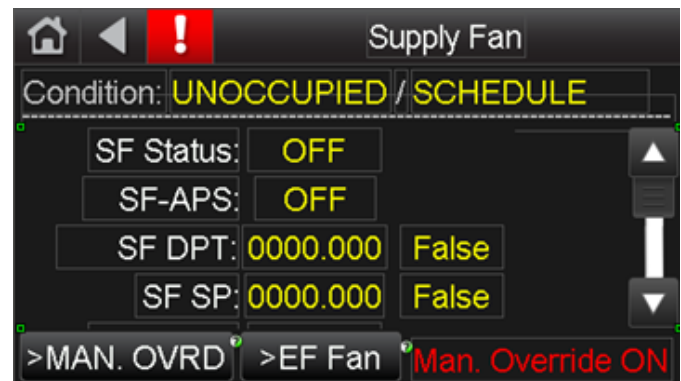

Fig. 11 — Supply Fan Status Screen

The following information may be shown on the on the Supply Fan status screen:

- SF Status is the command to start the supply fan (UO-09) on the LS-1628u controller.
- SF-APS is status feedback of the air proven switch or Supply Fan current sensor (UI-16) on the LS-1628u controller.
- The next parameter (shown as SF DPT above) will show the method of supply fan control (if equipped). The method of control will depend on the control configuration. Below are the common configurations:
 - SF DPT: The supply fan is set up for supply duct differential pressure transmitter (DPT) control and will control to the fan to the duct pressure set point (SF SP). The value next to the SF DPT is the current sensor reading in inches water gauge (in. wg). The value next to SF SP is the pressure set point (in. wg).
 - SF AMS: The supply fan is set up for airflow monitor station (AMS) control to the airflow set point (SF SP). The value next to SF AMS is the current AMS reading in cubic feet per minute (CFM). The value next to SF SP is the airflow set point in CFM.
 - ZN DPT: The supply fan is set up for zone differential pressure transmitter (DPT) control and will control to the zone pressure set point (SF SP). The value next to the ZN DPT is the current sensor reading (in. wg). The value next to SF SP is the pressure set point (in. wg).
- The SF Mod will display the percentage of the analog output (UO-01).
- Minimum is the minimum speed of the supply fan. The default minimum speed is 50% (adjustable)
- CFI Status will display the status of the Clogged Filter Indicator (CFI).
- OFF Timer reflects the 2 minutes (adjustable) delay for the supply fan shutdown.

The Exhaust Fan Status screen will be displayed if the unit has an exhaust fan and will show the status and parameters for the EF. See Fig. 12.

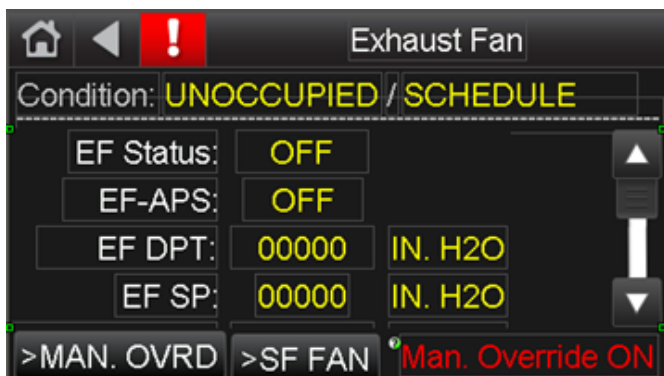

Fig. 12 — Exhaust Fan Status Screen

The following information may be shown on the Exhaust Fan status screen:

- EF Status is the command to start the exhaust fan (UO-09) on the LS-1628u controller.
- EF-APS is status feedback of the air proven switch or exhaust fan current sensor (UI-15) on the LS-1628u controller.
- The next parameter (shown as EF DPT above) will show the method of exhaust fan control (if equipped)
 - ZN DPT: The exhaust fan is set up for zone differential pressure transmitter (DPT) control and will control to the zone pressure set point (EF SP). The value next to the

- ZN DPT is the current sensor reading in in. wg. The value next to EF SP is the pressure set point in in. wg.
- EF AMS: The exhaust fan is set up for airflow monitor station (AMS) control to the airflow set point (EF SP). The value next to EF AMS is the current AMS reading in cubic feet per minute (CFM). The value next to EF SP is the airflow set point in CFM.
- EF DPT: The exhaust fan is set up for exhaust duct differential pressure transmitter (DPT) control and will control to the fan to the duct pressure set point (EF SP). The value next to the EF DPT is the current sensor reading in inches water gauge (in. wg). The value next to EF SP is the pressure set point (in. wg).
- The EF Mod will display the percentage of the analog output (UO-02).
- Minimum is the minimum speed of the exhaust fan. The default minimum speed is 25% (adjustable)
- OFF Timer reflects the 2 minutes (adjustable) delay for the exhaust fan shutdown.

The Energy Conservation Wheel (ECW) screen will be displayed if the unit has an ECW and will show the status and parameters for the ECW. See Fig. 13.

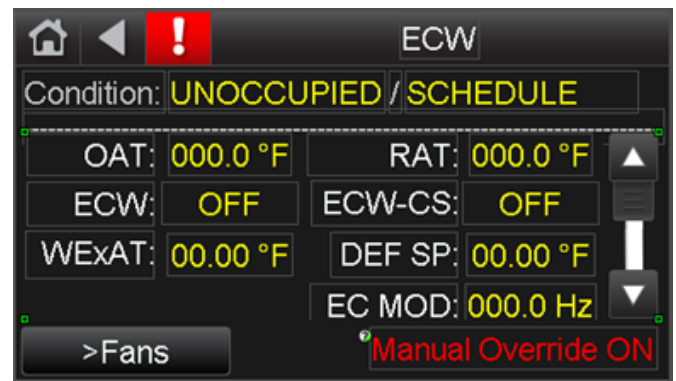

Fig. 13 — Energy Conservation Wheel Screen

The following information may be shown on the on the ECW screen:

- Outdoor air temperature (OAT) and return air temperature (RAT). The ECW will run when the difference of OAT and RAT is greater or less than 3°F. The ECW is the command to start the wheel (UO-15) on LS-1628u controller.
- ECW-CS is the status feedback from the current sensor. The CS will close once current is detected from the ECW motor.
- WExAT is the wheel exiting air temperature which controls the wheel's speed via the PID for defrost control (VFD defrost)
- DEF SP is the set point for the control of the ECW defrost control (Default is 25°F).
- EC MOD displays the speed of the ECW in hertz.

The Cooling 1 status screen shows the status and parameters for the first stage/circuit of cooling and the condensate overflow switch. For units with two refrigerant circuits (10+ tons), a Cooling 2 status screen will also be displayed with similar information. See Fig. 14.

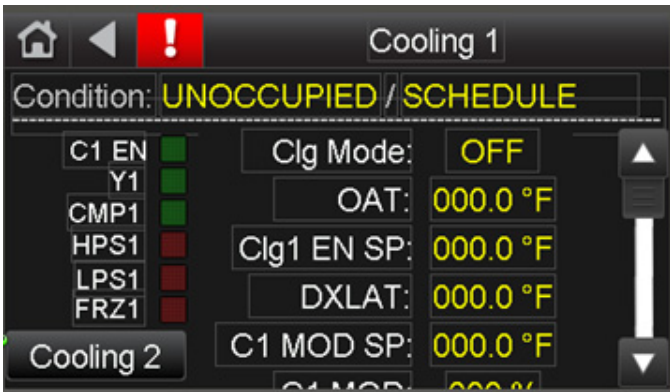

Fig. 14 – Cooling Status Screen

The following information may be shown on the on Cooling 1 status screen:

- Clg Mode status indicates that the conditions are met for cooling.
- The next parameter (shown as OAT above) indicates the sensor to enable compressor #1 or circuit #1. The type of sensor will change depending on control configuration. Common configurations include:
 - Outdoor air temperature (OAT)
 - Entering coil air temperature (ECAT, with ECW)
 - Outdoor air temperature vs supply air temperature (OAT vs SAT)
 - Outdoor air enthalpy (OAE)
- Clg1 En SP is the set point to enable circuit #1. The set point is adjustable on the Clg1 SP screen.
- DXLAT (DX coil leaving air temperature) indicates the sensor to modulate the compressor.
- Clg1 MOD SP is the set point for modulating the compressor. The set point is adjustable on the Clg1 SP screen.
- The C1 Mod will display the percentage of analog output (UO-07).
- COS Status will display the status of the condensate overflow switch (COS) for the condensate drain pan
- MIN OFF Timer reflects the 5 minutes the compressor must be off before restarting.
- MIN ON Timer reflects the 5 minutes the compressor must be on before shutdown.
- Heating to Cooling (Htg to Clg) Timer is a 10-minute timer for the heating mode to cooling mode switchover.
- RV Status will be displayed when the unit is a heat pump (62H ASHP, 62L HP, or 62W WSHP). The RV will display off when the unit is in cooling mode or on when the unit is in heat pump heating mode.
- Indicator Lights:
 - C1 EN will light when the enable conditions are met.
 - Y1 will light when the UO-10 or compressor #1 is commanded on.
 - CMP1 will light when the compressor #1 current sensor shows amperage.
 - HPS1 and LPS1 will be light in their normal state (N.C.). When they go into alarm the light will turn off.
 - FRZ1 will light when the freeze alarm is active for Compressor #1.

Units with two refrigerant circuits (size 10+ tons) will also have a Cooling 2 status screen. The above information will also be displayed for the second circuit (except for the COS).

The Reheat status screen shows the status and parameters for the liquid subcooling reheat (Sub-Cooling, if equipped) and hot gas reheat (ReHeat). See Fig. 15.

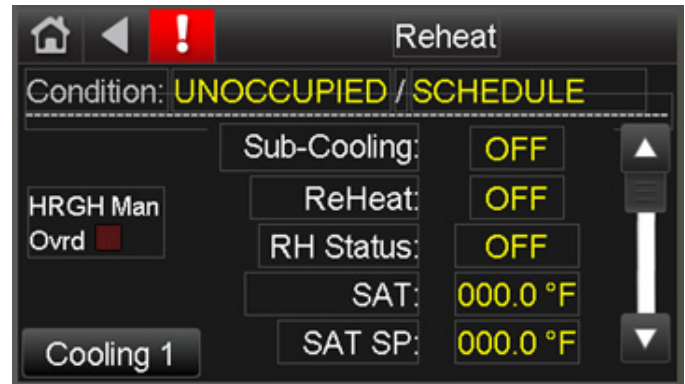

Fig. 15 – Reheat Status Screen

The following information may be shown on the on Reheat status screen:

- Sub-Cooling status will display the status of the liquid sub cooling coil (if equipped).
- Reheat Status will display the status of the hot gas reheat coil.
- Supply air temperature (SAT) indicates the sensor reading for the SAT sensor.
- SAT SP is the set point for modulating the reheat system. The set point is adjustable on the Clg 1 SP screen.
- RH Mod will display the percentage of analog output (UO-04).
- Indicator Lights:
 - HGRH Manual Override will light when placed in manual override

The Dehumidification 1 status screen shows the status and parameters for dehumidification mode for the first refrigerant circuit. For units with two refrigerant circuits (10+ tons), A Dehum 2 status screen will also be displayed with similar information. See Fig. 16.

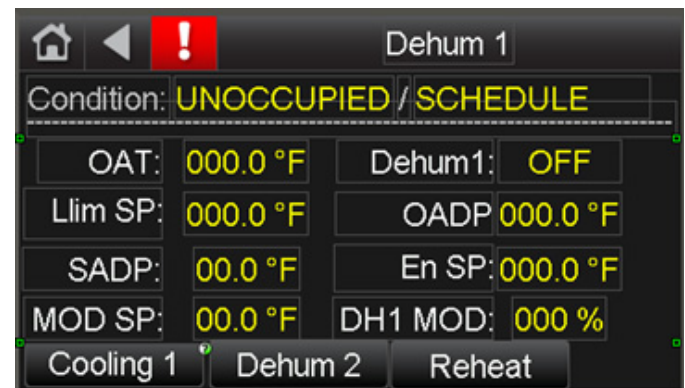

Fig. 16 – Dehumidification Status Screen

The following information may be shown on the on Dehum status screen:

- Outdoor air temperature (OAT)
- Dehum1 will display the status of the dehum mode.
- Lim SP is the low limit set point to enable the dehum mode (typically based on OAT).

- The next parameter (shown as OADP above) indicates the sensor to enable the dehum mode. The type of sensor will change depending on the unit configuration. Common configurations include:
 - Outdoor air dew point (OADP) vs supply air dew point (SADP)
 - Entering coil dew point (ECDP, with ECW) vs supply air dew point (SADP)
 - Supply air relative humidity (SARH)
- EN SP is the set point to enable dehumidification based on the configuration above.
- The next parameter (shown as SADP) status indicates the sensor to control cooling during dehum mode. The type of sensor will change depending on the unit configuration. Common configurations include:
 - Supply air dew point (SADP)
 - Supply air relative humidity (SARH)
- MOD SP is the set point to modulate the cooling system (lead compressor).
- DH1 Mod will display the percentage of analog output (UO-07) during dehumidification operation.

The Heating status screen shows the status and parameters the unit heat source (if equipped). See Fig. 17.

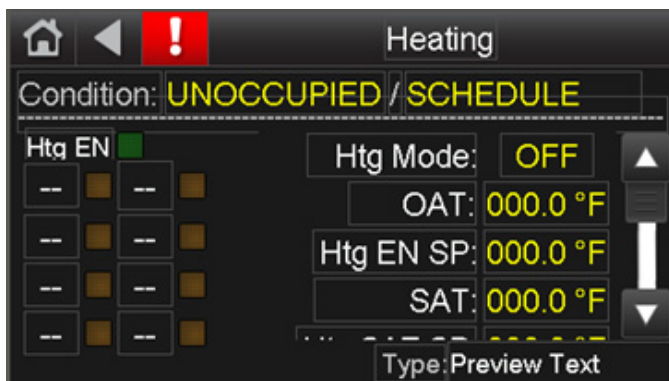

Fig. 17 — Heating Status Screen

The following information may be shown on the Heating status screen:

- Htg Mode status indicates that the conditions are met for heating.
- The next parameter (shown as OAT above) indicates the sensor to enable heating. The type of sensor will change depending on the unit configuration. Common configurations include:
 - Outdoor air temperature (OAT)
 - Entering coil air temperature (ECAT, with ECW)
- Htg En SP is the set point to enable heating. The set point is adjustable on the Htg SP screen.
- SAT indicates the unit supply air temperature sensor, which is used to modulate the heat source.
- Htg SAT SP is the supply air temperature set point for modulating the heat source. The set point is adjustable on the Htg SP screen.
- The Htg Mod will display the percentage of analog output (UO-06).
- Clg to Htg Timer is a 10-minute timer for the cooling mode to heating mode switchover.
- Indicator Lights:
 - Htg EN will light when the heating enable condition is met.

The Heat Pump 1 status screen shows the status and parameters the heat pump units (62H, 62L HP, and 62W only). Units with two refrigerant circuits (10+ tons) will also have a Heat Pump 2 status screen. See Fig. 18.

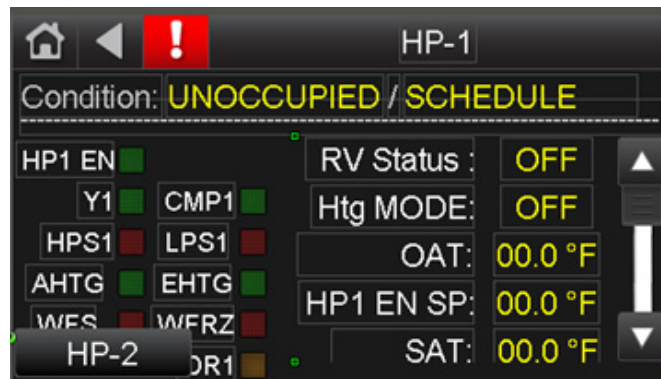

Fig. 18 — Heat Pump 1 Status Screen

The following information may be shown on the Heat Pump 1 status screen:

- RV Status will display Off when the heat pump unit is in cooling mode and ON when the unit is in heat pump heating mode.
- Htg Mode status indicates that the conditions are met for Heat pump heating.
- OAT indicates the sensor to enable compressor #1 or circuit #1.
- HP1 En SP is the set point to enable compressor #1 or circuit #1. The set point is adjustable on the HP1 SP screen.
- SAT indicates the sensor to modulate the compressor.
- MOD SP is the set point for modulating the compressor. The set point is adjustable on the HP1 SP screen.
- The C1 Mod will display the percentage of analog output (UO-07).
- MIN OFF Timer reflects the 5 minutes the compressor must be off before restarting.
- MIN ON Timer reflects the 5 minutes the compressor must be on before shutdown.
- Clg to Htg Timer is a 10-minute timer for the heating mode to cooling mode switchover.
- Indicator Lights:
 - HP1 EN will light when the enable conditions are met.
 - Y1 will light when the UO-10 or compressor #1 is commanded on.
 - CMP1 will light when the compressor #1 current sensor show amperage.
 - HPS1 and LPS1 will light in their normal state (N.C.). When they go into alarm the light will go off.
 - AHTG will light when the auxiliary heat is “on”, all compressors will shut down.
 - EHTG will light when the emergency heat is “on” and the heat pump 1 shut down.
 - WFS will light when there is water flow (used on 62L WSHP and 62W units only).
 - WFRZ will light when the water freeze stat is closed or normal state (used on 62L WSHP and 62W units only).
 - DR1 will light when the defrost relay is activated (used on 62H and 62L ASHP units only).

Set Points Screens

The set points screen can be accessed from Home screen (*Home*→*Stp/DB*) or Tech Setting screen (*Set Up*→*Set Point/DB*) and contains links to all available component, safety, and mode set point screens. See Fig. 19.



Fig. 19 – Set Points

Pressing a link will open the set point screen for the indicated component. Because set points can affect unit operation, an Admin (1111) or Factory password is required to access set point screens.

SET POINTS SCREENS OVERVIEW

Set point (SP) screens list the operating set points for the listed component or system. The SP screen will list the applicable devices (left side of the screen), the operating set point (right side of the screen) and the sensor that the set point is referencing (middle of the screen). The listed sensor could be a physical sensor or calculated value based on multiple sensors. The set point and the sensor will share the same units.

The availability of components, sensors, and set points are based on the unit configuration and control configuration. Refer to the Config screen under Tech Settings for available configurations.

Fan Set Points

The Fan set points screen (*Home*→*Stp/DB*→*Fan SP*) displays set points for the supply and exhaust (if equipped) fans. See Fig. 20.

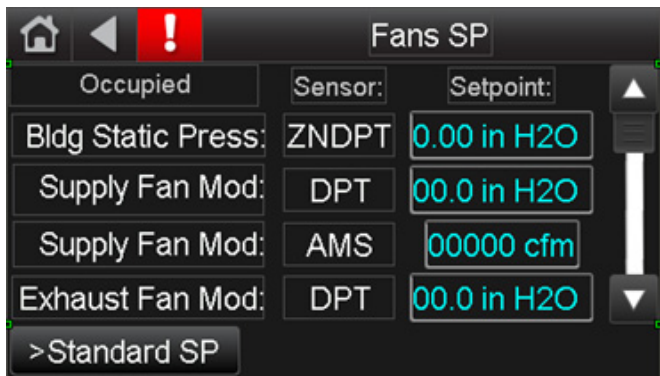

Fig. 20 – Fan SP

Each fan can only control to one set point, so the screen should only list one set point for each fan. The following set points may be displayed on the Fans SP screen:

Supply Fan or Exhaust Fan Mod:

- Airflow measuring (AMS) - fan will modulate to the CFM set point
- Duct pressure (DPT) - fan will modulate to the duct pressure set point (in. wg).
- Zone pressure (ZNDPT) - fan will modulate to maintain the building pressure set point (in. wg). Typical for units with exhaust fan. May also be used on supply only units for space pressure control.

ECW Set Points

The ECW set points screen (*Home*→*Stp/DB*→*ECW SP*) displays set points for the energy conversation wheel (if equipped). See Fig. 21.

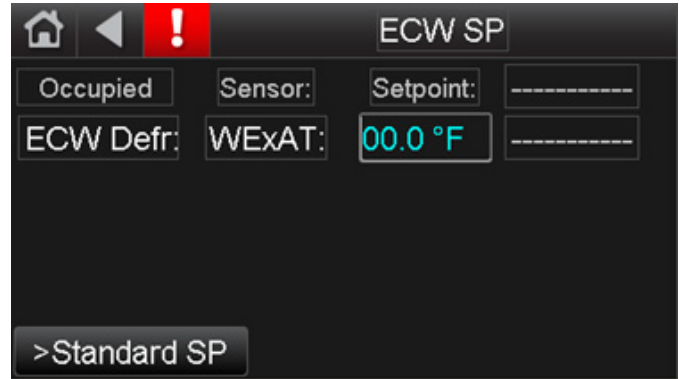

Fig. 21 – ECW SP

The following set points may be displayed on the ECW SP screen:
ECW Defrost:

- WExAT - when the wheel exhaust air temp drops below this temperature, the ECW slows to prevent frosting (default SP is 25°F, adjustable).

Cooling 1 Set Points

The Cooling 1 set points screen (*Home*→*Stp/DB*→*Clg1 SP*) displays the set points for the first stage of cooling (C1) and cooling mode. See Fig. 22.

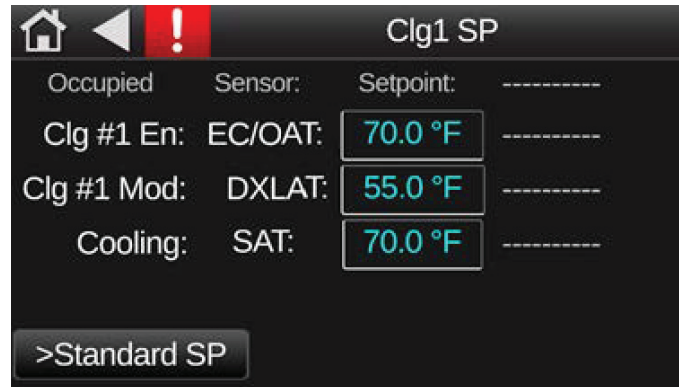

Fig. 22 – Clg 1 SP

Units 45 tons and above use tandem compressors, so C1 will be two compressors on the first circuit. The following set points may be displayed on the Clg 1 SP screen:

COOLING 1 ENABLE

- OAT - C1 is enabled when the outdoor air temp is above the set point
- OAE - C1 is enabled when the outdoor air enthalpy is above the set point. Enthalpy is calculated from outdoor air temp and RH%
- OAT and SAT - C1 is enabled when the outdoor air temp is above the supply air temp set point.
- ECAT - for units with ERV, C1 is enabled when the entering coil air temp (treated OA after ECW) is above the ECAT set point.

COOLING 1 MOD

- DXLAT - C1 will modulate to the evaporator (DX) coil leaving air temperature. All 62W units feature a modulating lead circuit compressor. The DX LAT is also used during dehumidification mode and should match the required supply air dew point.

COOLING

- SAT - In cooling mode, the unit will operate to maintain the cooling supply air temperature set point. If the unit SAT drops below set point, HGRH is enabled to reheat the SAT up to set point
- ZAT - Used for zone air temp override. When the ZAT is above set point, unit will enter ZAT/SAT override.

Cooling 2 Set Points

The Cooling 2 set points screen (*Home*→*Stp/DB*→*Clg2 SP*) displays the set points for the second stage of cooling (C2). Only available on units 10 tons and larger. See Fig. 23.

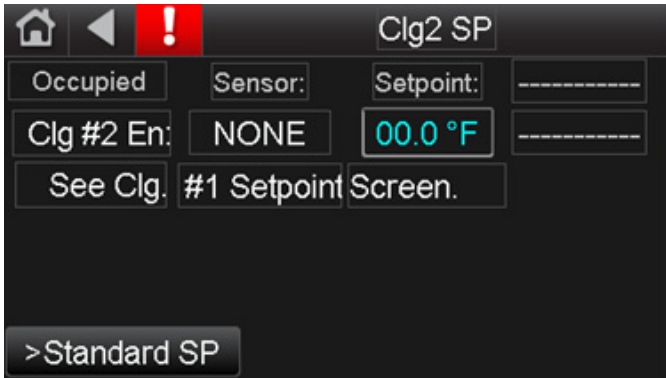

Fig. 23 — Clg 2 SP

Units 40 tons and above use tandem compressors, so C2 will be two compressors on the second circuit. The following set points may be displayed on the Clg 2 SP screen:

COOLING 2 ENABLE

- OAT - C1 is enabled when the outdoor air temp is above the set point
- OAE - C1 is enabled when the outdoor air enthalpy is above the set point. Enthalpy is calculated from outdoor air temp and RH%
- OAT vs. SAT - C1 is enabled when the outdoor air temp is above the supply air temp set point.
- ECAT/ECAE - for units with ERV. Operation is based upon entering coil (EC) conditions, which is the pre-treated outdoor air leaving the ECW and entering the evap coil.

Dehumidification Set Points

The Dehumidification set points screen (*Home*→*Stp/DB*→*DH SP/DB*) displays the set points and deadband for dehumidification mode. See Fig. 24.

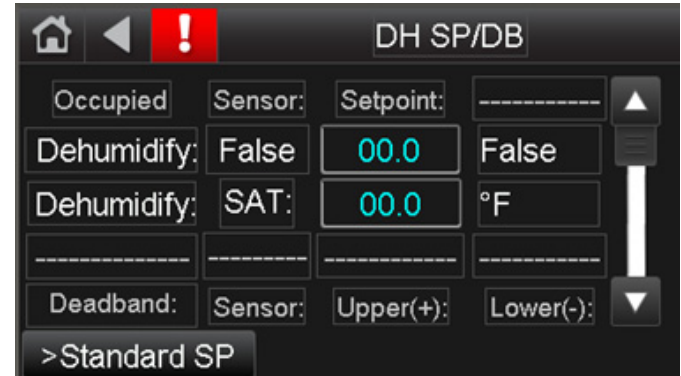

Fig. 24 — DH SP/DB

When dehumidification mode is enabled, the cooling circuit (compressors) are controlled to the DX LAT set point (Clg 1 SP) to dehumidify the hot/humid outdoor air. The cooled and dehumidified air then passes to through the reheat system, which heats the supply air up to the SAT set point. The SAT set point should be at or near the space temperature set point (68 to 72°F) to prevent overcooling the space. The following set points may be displayed on the Dehum SP/DB screen:

DEHUM ENABLE

- OADP vs SADP - Dehum mode is enabled when the outdoor air dew point is above the supply air dew point set point
- OADP - Dehum mode is enabled when the outdoor air dew point is above the set point
- OAE - Dehum mode is enabled when the outdoor air enthalpy is above the set point.
- SARH - Dehum mode is enabled when the supply air RH% is above set point.
- ECAT/ECAE - for units with ERV. Operation is based upon entering coil (EC) conditions, which is the pre-treated outdoor air.

DEHUM

- SAT - In dehumidification mode, the HGRH will operate to maintain the dehum supply air temperature by reheating the air leaving the evaporator coil to the SAT set point.

DEADBAND

SAT - The upper and lower deadband for the reheat supply air temperature.

Heating Set Points

The Heating set points screen (*Home*→*Stp/DB*→*Htg SP/DB*) displays the set points and deadbands for the heat source and heating mode (if equipped). See Fig. 25.

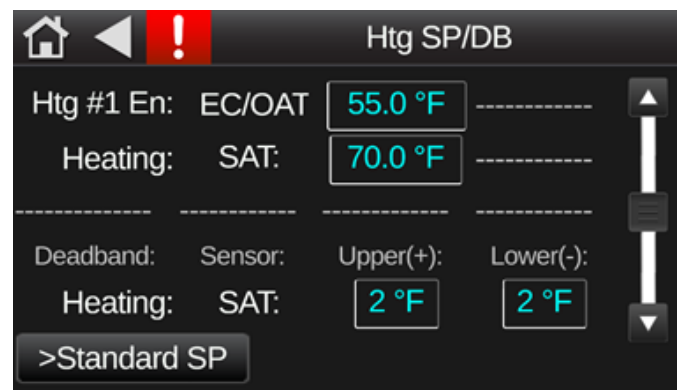

Fig. 25 — Htg SP/DB

The following set points may be displayed on the Htg SP/DB screen:

HEATING 1 ENABLE

- OAT - Heating mode is enabled when the outdoor air temp is below set point.
- OAT vs SAT - Heating is enabled when the outdoor air temp is below the heating supply air temp set point.
- ECAT - for units with ERV. Operation is based upon entering coil (EC) conditions, which is the pre-treated outdoor air

HEATING

- SAT - In heating mode, the unit will operate the heat source to maintain the heating supply air temperature set point.
- ZAT - Used for zone air temp override. When the ZAT is below set point, unit will enter ZAT/SAT override.

DEADBAND

SAT - The upper and lower deadband for the heating supply air temperature.

Heat Pump Heating Set Points (62H, 62L and 62W Heat Pumps Only)

The Heat Pump set points screen (*Home*→*Stp/DB*→*HP1 SP or HP2 SP*) displays the set points and for the heat pump and heat pump heating mode. See Fig. 26.

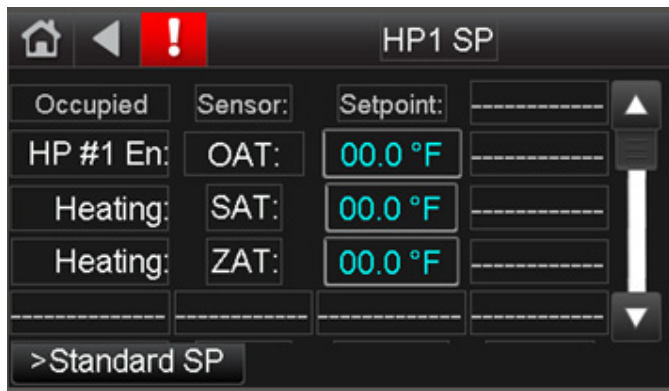

Fig. 26 — HP 1 SP

The following set points may be displayed on the HP SP/DB screen:

HEAT PUMP 1 AND 2 ENABLE

- OAT - Heat pump heating mode is enabled when the outdoor air temp is below set point.
- OAT vs SAT - Heat pump heating is enabled when the outdoor air temp is below the heating supply air temp set point.
- ECAT - for units with ERV. Operation is based upon entering coil (EC) conditions, which is the pre-treated outdoor air.

HEATING

- SAT - In heat pump heating mode, the unit will operate the compressors to maintain the heat pump heating supply air temperature set point.
- ZAT - Used for zone air temp override. When the ZAT is below set point, unit will enter ZAT/SAT override.

DEADBAND

SAT - The upper and lower deadband for the heating supply air temperature.

Limits/Safety Set Points

The Limits and Safeties set points screen (*Home*→*Stp/DB*→*Lim/Safety*) displays set points for unit safeties, including lockouts and freeze protection. See Fig. 27.

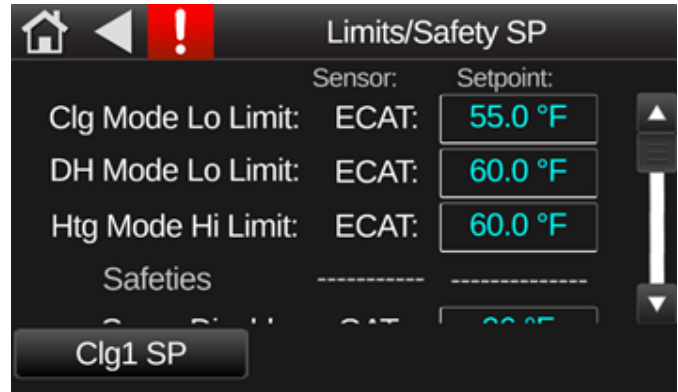

Fig. 27 — Limit/Safety SP/DB

The following set points may be displayed on the Limit/Safety SP screen:

CLG MODE LO LIMIT

- OAT - disables cooling mode when the outdoor air temp is below set point.
- ECAT - For units with ECW, disables cooling mode when the entering coil air temp (pre-treated outdoor air leaving ECW) is below set point.

DH MODE LO LIMIT

- OAT - disables dehum mode when the outdoor air temp is below set point.
- ECAT - For units with ECW, disables cooling mode when the entering coil air temp (pre-treated outdoor air leaving ECW) is below set point.

HTG MODE HI LIMIT

- OAT - disables heat mode when the outdoor air temp is above set point.
- ECAT - For units with ECW, disables heating mode when the entering coil air temp (pre-treated outdoor air leaving ECW) is above set point.

COMP 1 DISABLE/COMP 2 DISABLE

- OAT - disables compressor when the outdoor air temp is below set point.
- ECAT - For units with ECW, disables compressor when the entering coil air temp (pre-treated outdoor air leaving ECW) is below set point.
- OADP - disables compressors when outdoor air dew point is below set point.
- ECDP - For units with ECW, disables compressor when the entering coil air dew point (pre-treated outdoor air leaving ECW) is below set point.

UPPER FREEZE

- DX LAT - After a lower freeze trip and a 5 minute minimum off cycle, the unit will enable compressor operation after the DX LAT increases above the upper freeze set point. There is a 5 minute minimum off cycle.

MIDDLE FREEZE

- DX LAT - When the DX LAT drops below the middle freeze set point, the compressor will unload.

LOWER FREEZE

- DX LAT - When the DX LAT drops below the lower freeze set point for a period of 10 minutes, the compressor is disabled until the DX LAT rises above the upper freeze set point.

ECW DEFROST

- WExAT - when the wheel exhaust air temp drops below this temperature, the ECW slows to prevent frosting.

Unoccupied Set Points (Units with Night Setback ETO only)

The Unoccupied set points screen (*Home*→*Stp/DB*→*Unoc SP*) displays the set points for unoccupied operation. See Fig. 28.

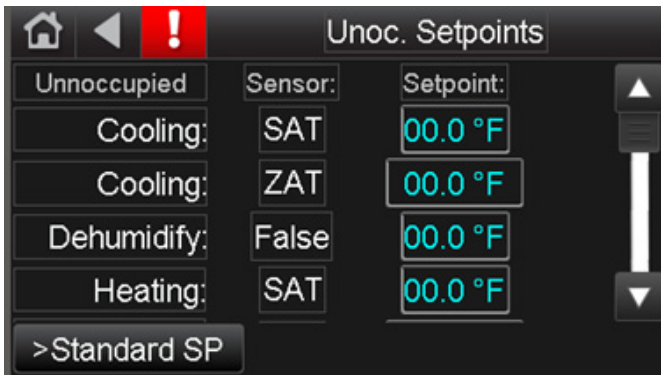

Fig. 28 — Unoc. SP

Unoccupied operation is only available on units with Night Setback ETO, which includes night setback mode and return air damper. Night Setback is not field installable. The following set points may be displayed on the unoccupied set points screen:

COOLING

- SAT - In unoccupied cooling mode, the unit will operate to maintain the cooling supply air temperature set point. If the unit SAT drops below set point, HGRH is enabled to reheat the SAT up to set point.
- ZAT - When the zone air temp rises above the set point, the unit enters unoccupied cooling mode.

DEHUMIDIFY

- ZRH - When the zone relative humidity rises above the set point, the unit enters unoccupied dehum mode.

HEATING

- SAT - In unoccupied heating mode, the unit will operate the heat source to maintain the heating supply air temperature set point.
- ZAT - When the zone air temp falls below the set point, the unit enters unoccupied heating mode.

Tech Settings

The Tech Settings screen can be accessed from the Home screen (*Home*→*Set Up*) and displays links to all technical settings for the unit. See Fig. 29.

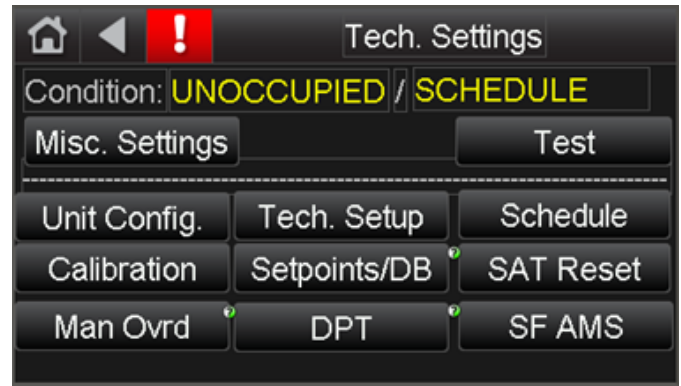

Fig. 29 — Tech Settings

Pressing a link will open the associated screen. Because tech settings can affect unit operation, an Admin (1111) or Factory password is required to access tech settings.

The availability of settings is based on the unit configuration and control configuration. Refer to the Config screen under Tech Settings for available configurations.

Unit Control Configuration

The unit configuration screen (*Home*→*Set Up*→*Unit Config.*) displays the unit control configuration information. See Fig. 30.

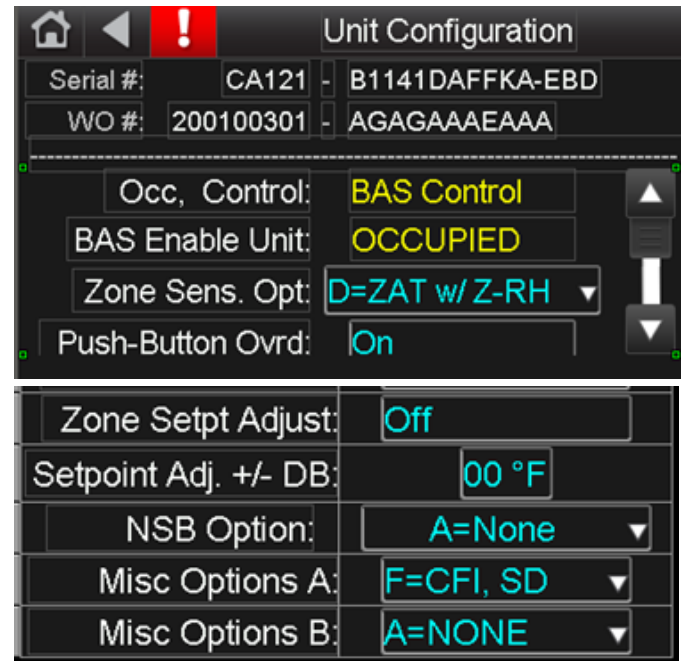

Fig. 30 — Unit Config

The top of the unit configuration screen shows the unit model and serial information. The factory work order number is also included. These numbers can be referenced when requesting support on the equipment.

Occ Controls lists the method of unit occupancy control (BAS, local schedule, 24/7, or start/stop switch). The method of occupancy control can be changed in the Tech Set Up screen (*Home*→*Set up*→*Tech. Set Up*). The BAS enable section shows the current unit status (disabled, enabled).

The following settings change be adjusted on the Unit Control Configuration screen:

ZONE SENSOR OPTION

NOTE: The 62W unit is not intended to maintain space conditions. The zone air sensor option is only intended for energy purposes (ZAT/SAT reset) and to help offset some of the space load (ZAT/SAT reset or Night Setback).

The zone sensor option is used only for ZAT/SAT reset or Night Setback operation (ETO). See the Tech Set Up screen (*Home*→*Set Up*→*Tech. Set Up*) for ZAT/SAT reset settings. See Misc. Options B below for Night Setback configuration. The following zone sensor options are available:

- None - no zone air temperature sensor.
- ZAT Only - zone air temp (Carrier ZS) sensor for use with ZAT reset or Night Setback (unoccupied cooling and heating).
- ZAT and Z-RH - zone air temp and RH (Carrier ZS-RH) sensor used for ZAT reset or Night Setback (unoccupied cooling and heating).
- CO₂ - not used with 62W units.

PUSH-BUTTON OVERRIDE

Allows a zone sensor with push-button occupancy override to override unoccupied mode and enter the unit into occupied mode for a set period. Each press of the push button override provides 30 minutes of occupied operation, up to 150 minutes. Requires a ZS plus or pro zone sensor. The following settings are available:

- Off - push button occupancy override disabled.
- On - push button occupancy override enabled.

ZONE SET POINT ADJUST TECH SET UP

Allows a zone sensor with set point adjustment to adjust the zone air temperature set point. Requires a zone sensor option to be selected.

- Off - zone set point adjustment disabled.
- On - zone set point adjustment enabled.

SET POINT ADJUST LIMIT (+/-)

Set a limit to how far above or below set point the set point override can adjust. The set point adjust range is $\pm 1^{\circ}\text{F}$ to $\pm 5^{\circ}\text{F}$.

NIGHT SET BACK (NSB) OPTION

Night Setback operation (ETO) allows a 62W unit to condition the space using recirculated air during unoccupied mode. Requires a return air damper. Used with systems like induction beams that require 62W units airflow for space conditioning. The following settings are available:

- None - night setback operation disabled.
- NSB Cooling - unit will perform unoccupied cooling operation using return air (requires zone air temp sensor).
- NSB Dehum - unit will perform unoccupied dehumidification operation using return air (requires zone air RH sensor).
- NSB Heating - unit will perform unoccupied heating operation using return air (requires zone air temp sensor).

MISC OPTIONS A

Used for safety control options, including:

- None - no options (not used on 62W units).
- CFI - clogged filter indicator (used on all 62W units).
- COS - condensate overflow switch (used on all 62W units).
- SD - smoke detector. Used on 62W units with the optional factory installed return air smoke detector or for field supplied smoke detectors.

MISC OPTIONS B

Used for shutdown/occupancy control options, including:

- None - no shutdown options.

- EMR - unit to have energy management relay (EMR) functionality. Normal occupancy control to be followed when the relay is closed (UI-27 of the controller). Unit to enter unoccupied mode when the relay is open, after normal shutdown procedure (typical 2-minute shutdown). Normal operation is restored when the relay closes. See below for wiring and relay requirements.
- EMSD - unit to have emergency shutdown relay and EMSD functionality. Normal occupancy control to be followed when the relay is closed (UI-27). Unit to enter emergency shutdown mode, shortly after the relay is open. Normal operation is restored when the relay closes. See below for wiring and relay requirements.

EMR/EMSD Wiring

Field provided EMR/EMSD relay must be wired to UI-27 of the expander module. When the relay is closed (contact closure), the unit operation is enabled. When the relay is open (contact open), the unit enters emergency shutdown mode and is disabled (EMSR) or the unit enters unoccupied mode (EMR) and goes through the typical shutdown process. See Fig. 31.

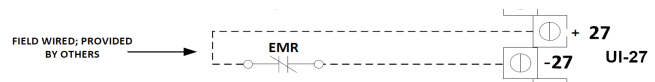

Fig. 31 — EMR Relay Wiring

Tech Settings

The tech settings screen (*Home*→*Set Up*→*Tech. Set Up*) displays technical settings information for the unit and contains set points related to control and component operation. See Fig. 32.

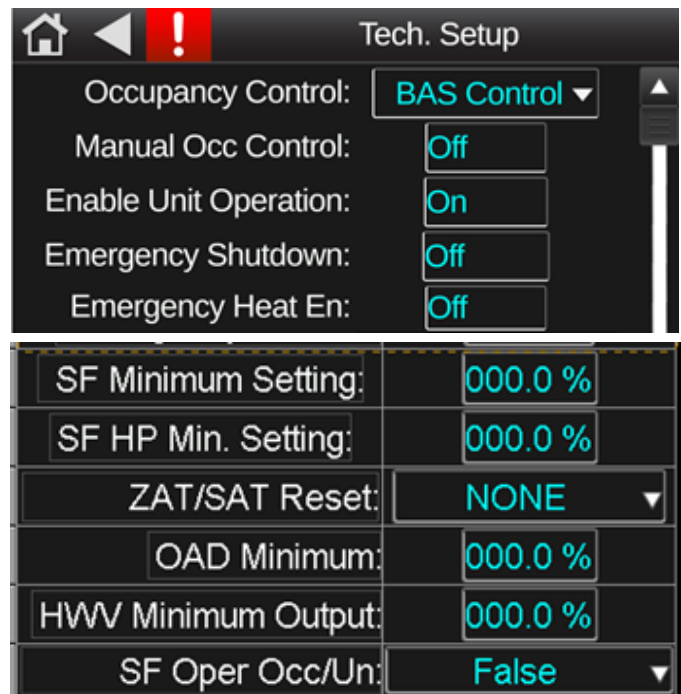

Fig. 32 — Tech Set Up

The following settings change be adjusted in the tech set up:

OCCUPANCY CONTROL

Determines the operation of the unit between occupied and unoccupied/disabled mode.

- BAS control - occupancy will be determined by an external building automation system and communicated to the unit.
- Local schedule - occupancy will be determined by a schedule set up in the local unit control.
- 24/7 operation - unit will operate in occupied mode continuously.

MANUAL OCC CONTROL

Manually overrides the current occupancy level. The Occupancy Control setting must be set to BAS control for manual occupancy control to function.

- Off - no occupancy override.
- Occupied - unit will be in occupied mode regardless of occupancy control command.
- Unoccupied - unit will be in unoccupied mode regardless of occupancy control command.

ENABLE UNIT OPERATION

Used to enable or disable unit operation.

- On - unit can enter occupied or unoccupied mode.
- Off - unit is disabled and will not enter any mode.

EMERGENCY SHUTDOWN

Used to force an emergency shutdown of the unit.

- Off - Unit operation is enabled.
- On - Unit is placed in emergency shutdown, all components will be disabled.

EMERGENCY HEAT ENABLE (62H, 62L, AND 62W HEAT PUMPS ONLY)

Allows an auxiliary heat source to be used an emergency heat if the heat pump heating is disabled.

- Off - emergency heat disabled.
- On - emergency heat enabled.

SF MINIMUM SETTING

Sets the minimum operating speed for the supply fan for all operating modes (except heat pump heating on 62H, 62L HP, and 62W units). The minimum speed is based on an operating range of 0-100%.

SF HP MINIMUM SETTING

Sets the minimum operating speed for the supply fan during heat pump heating mode (62H, 62L HP, and 62W units only). The minimum speed is based on an operating range of 0-100%. The default setting is 85%.

ZAT/SAT RESET

Allows the 62W unit to reset the supply air temperature set point based on an external temperature input. ZAT reset requires the use of a Carrier ZS sensor or other Rnet sensor. See SAT Reset screen (*Home*→*Set Up*→*SAT Reset*) for SAT reset set points. Below are the available configurations for SAT reset:

- None - SAT reset disabled.
- ZAT CLG - SAT reset is active for cooling mode based on zone air temp.
- ZAT HTG - SAT reset is active for heating mode based on zone air temp.
- ZAT DEH - SAT reset is active for dehum mode based on zone air temp.
- OAT CLG - SAT reset is active for cooling mode based on outdoor air temp.
- OAT HTG - SAT reset is active for heating mode based on outdoor air temp.
- OAT DEH - SAT reset is active for dehum mode based on outdoor air temp.

HWV MINIMUM OUTPUT

Sets the minimum output for the hot water valve during heating mode. The minimum output is based on an operating range of 0-100%. Setting a minimum output is recommended for preventing freezing of the hot water coil.

SUPPLY FAN OCCUPIED/UNOCCUPIED OPERATION

Determines how the supply fan will behave during occupied and unoccupied mode. Unoccupied mode is only with night setback ETO.

- 1 = Continuous/ Demand - the supply fan operates continuously during occupied mode, only on demand for cooling, heating, or dehum during unoccupied mode.
- 2 = Continuous/ Continuous - the supply fan operates continuously during occupied mode and unoccupied mode.
- 3 = Demand/ Demand - the supply fan only operates with demand for cooling, heating, or dehum during occupied or unoccupied mode (not used with 62W units).

SCHEDULES

The Schedules screen (*Home*→*Set Up*→*Schedule*) displays the active local schedule and allows a user to add new schedules. See Fig. 33 and 34.

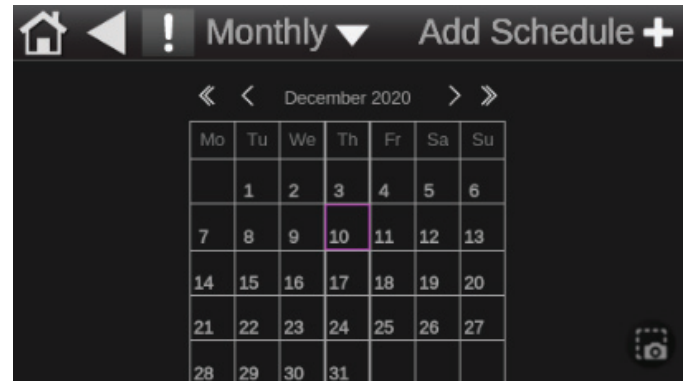

Fig. 33 — Monthly Schedule

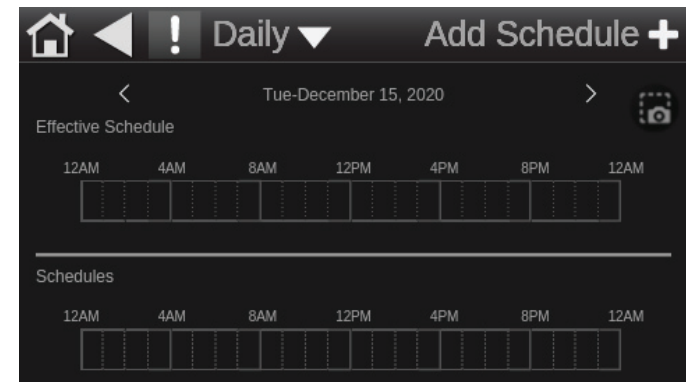

Fig. 34 — Daily Schedule

VIEWING LOCAL SCHEDULES

See Table 7.

Table 7 — Local Schedule Options

	Click on the View Schedule button to change between daily, weekly, or monthly view.
	Click on the forward and backwards arrow to change the date range of the schedule in view.
	Click on any day to view the effective schedule for the day

ADDING NEW LOCAL SCHEDULES

NOTE: Local schedules will only be effective if the unit occupancy control is configured for local schedule. See Tech Set Up screen for configuration options.

1. Click on the  button next to Add Schedule to add a new schedule.
2. Choose On Schedule (Occupied) or Off Schedule (Unoccupied).
3. Choose Schedule Priority Type: Normal or Override.
4. Choose Schedule Type: Dated, Weekly, or Continuous.
5. Determine Start and End Time and Date of Schedule.
6. Save the schedule. The system uploads the schedule to the controller.

ADDING MULTIPLE PERIODS TO A SCHEDULE

A weekly schedule can have multiple periods. For example, the first period could be every Monday through Friday, 8:00 am to 5:00 pm. The second periods could be every Monday through Wednesday 6:00 pm to 8:00 pm. You can create up to 4 period for a day, and up to 28 periods for a week.

1. Create a weekly schedule for the first period. See Adding New Local Schedule.
2. In the Schedules screen, touch the green bar for the schedule to which a period should be added.
3. In the Schedule (day View) screen, touch the schedule name or green bar (not the Effective Schedule bar) and press Next.
4. Press +Period.
5. Set the times and days for the new period; for example, Monday through Wednesday, 6:00 pm to 8:00 pm.
6. Save the period.

Sensor Calibration

The Sensor Calibration screen (*Home*→*Set Up*→*Calibration*) displays the calibration settings for unit sensors. See Fig. 35.

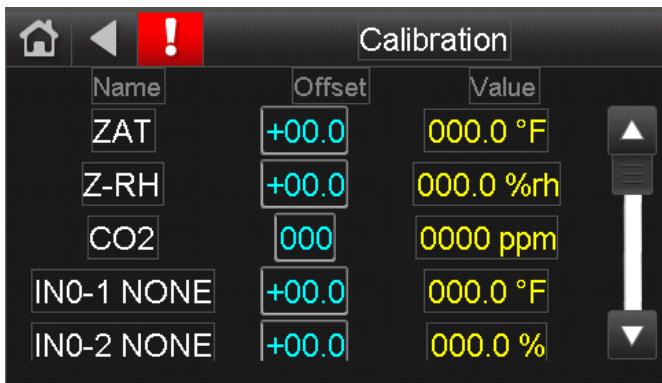

Fig. 35 — Calibration

The calibration screen can be used to adjust the effective sensor reading by a fixed off set (+ or -) if the unit sensor reading is different from a known reading source. Applying offsets can also be useful for unit troubleshooting to influence unit operation (force the unit into a mode) or to quickly determine a faulty sensor. Faulty temperature sensors will typically display a value of -60°F (open) or 296°F (short).

SUPPLY AIR TEMPERATURE (SAT) RESET

The SAT reset screen (*Home*→*Set Up*→*Calibration*) displays the set points for SAT reset operation. See Fig. 36.

The SAT reset functions operates based on user configured set points and a referenced temperature. See the Tech Settings screen

(*Home*→*Set Up*→*Tech Set Up*) to set and select the method of operation.

- ZAT/OAT Ratio - ratio that the ZAT/OAT deviation from set point has on the SAT.
- SAT Ratio - ratio that the SAT is reset based on the ZAT ratio.
- SAT Max Change - maximum reset amount.
- Clg ZAT/OAT SP - zone air temp or outdoor air temp set point for cooling operation.

Htg ZAT/OAT SP - zone air temp or outdoor air temp set point for heating operation.



Fig. 36 — SAT Reset Set Points

SAT RESET OPERATION

When SAT reset is enabled, the unit is in the appropriate mode based on the configuration (cooling, heating, or dehum), and the zone air temp is above or below the zone air temp set point, SAT reset is activated. The supply air temperature set point is reset by the SAT ratio based on the ZAT deviation from ZAT set point and the ZAT ratio.

Based on the settings in Fig. 36, if the unit was configured for SAT Reset - ZAT CLG and the zone air temp 72°F (2°F above the cooling ZAT set point of 70°F), the unit would enter SAT reset mode. Since the SAT ratio is 3°F SAT for every 1°F ZAT, the SAT would be reset down by 6°F, up to a maximum of 10°F.

Manual Override

The Manual Override screen (*Home*→*Set Up*→*Man Ovr*d) displays the settings for overriding modulating components. See Fig. 37.

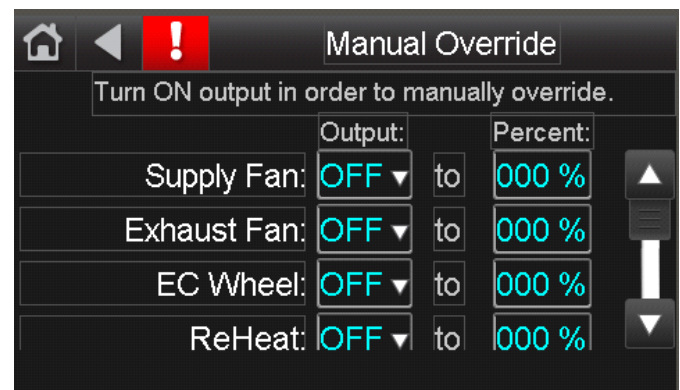

Fig. 37 — SAT Reset Set Points

The Manual Override screen can be used to override the modulation for a component when the component is operating. Manual overrides can be useful for troubleshooting or for unit start-up. It is common to use the supply fan and exhaust fan manual overrides for adjusting the fan speeds during air balancing.

For constant volume (CV) applications, the manual overrides can be set for the supply and exhaust fan. The supply fan exhaust fans will operate at the manual override speed when ever the fan is commanded to run.

To set a manual override:

1. Set the output value next to the desired component to On.
2. Set the percent operation to the desired operating set point of the component. The percent is based on an operating range of 0-100%.
3. The override will apply when the output is set to On.
4. To disable a manual override, set the output to Off.

Differential Pressure Transmitter Summary

The Differential Pressure Transmitter (DPT) Summary screen (*Home*→*Set Up*→*DPT*) displays the set points for differential pressure transmitter (DPT) for supply and exhaust fan control. This screen will only be displayed on units with DPT control, such as supply fan duct pressure control or exhaust fan building control. See Fig. 38.

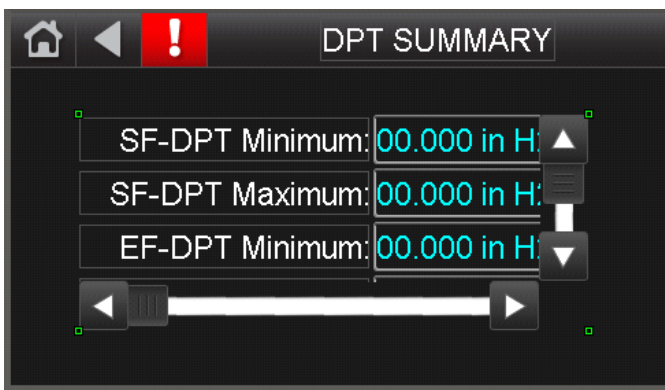

Fig. 38 – DPT Summary

After the DPT sensor is field installed and configured, the minimum reading and maximum reading settings from the sensor should be programmed into the DPT summary. For example, if the SF-DPT duct pressure sensor is configured for a range of 0-5 in., the SF-DPT minimum should be programmed for 0 in. and the maximum programmed for 5 inch.

Airflow Monitor Station (AMS) Summary

The AMS summary screen (*Home*→*Set Up*→*AMS Summary*) displays the status airflow monitor station (AMS) for supply and exhaust fan control. See Fig. 39.

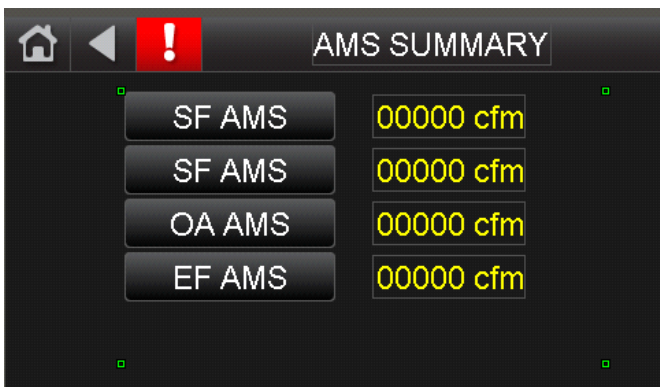

Fig. 39 – AMS Summary

The AMS summary screen contains links to the AMS settings screens.

Supply Fan and Exhaust Fan AMS Settings

The SF and EF AMS setting screen (*Home*→*Set Up*→*AMS Summary*→*SF* or *EF AMS*) displays the settings airflow monitor station (AMS) for supply and exhaust fan. This screen will only be displayed on units with factory installed building supply or exhaust airflow station. See Fig. 40.

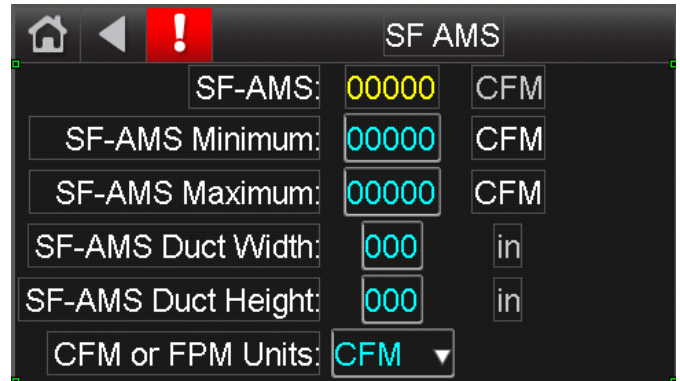

Fig. 40 – AMS Summary

The AMS summary screen contains links to the AMS settings screens.

Miscellaneous Settings

The miscellaneous settings screen (*Home*→*Set Up*→*Misc. Settings*) contains settings related to the unit controller, Equipment Touch, and other technical settings. See Fig. 41.

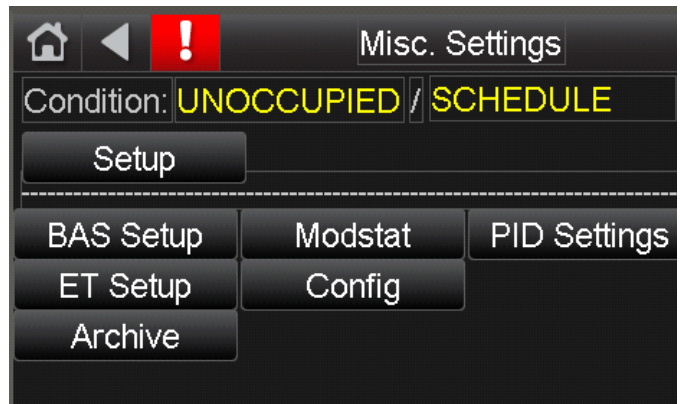

Fig. 41 – MISC Settings

Building Automation System (BAS) Module Set Up

The BAS module set-up screen (*Home*→*Set Up*→*Misc Settings*→*BAS Set Up*) contains links to screens that are needed for setting up network communication with the 62W controller. See Fig. 42.

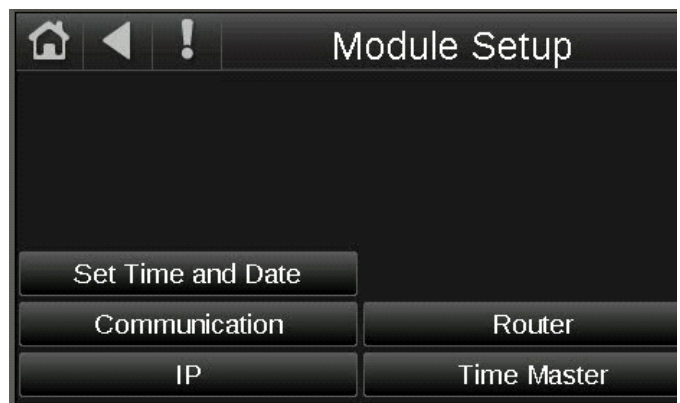

Fig. 42 – Misc Settings

Set Time and Date

The Set Time and Date screen (*Home*→*Set Up*→*Misc Settings*→*BAS Set Up*→*Set Time and Date*) allows the user to set the current time and date for the controller. Setting the time and date are required if a local schedule will be used. See Fig. 43.

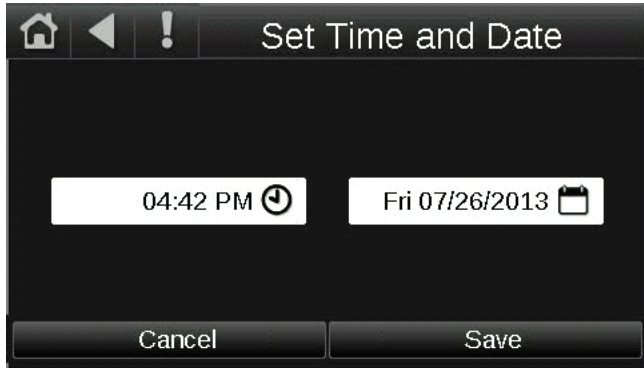

Fig. 43 – Misc Settings

The time and date will be kept current in the controller, if the controller has power and the battery back-up has sufficient voltage. To change the time or date:

1. Click on the clock icon to change the time.
2. Use the keypad or arrow keys to change the time.
3. Press done after changing the time.
4. Click on the calendar icon to change the date.
5. Use the keypad or arrow keys to change the date.
6. Press done after changing the date.
7. Press save on the Set Time and Date screen to save the changes.

Communication

The Communication screen (*Home*→*Set Up*→*Misc Settings*→*BAS Set Up*→*Communication*) allows the user to set the BACnet device ID and other related networking settings. See Fig. 44. See Appendix A - BAS Commissioning for more details on BAS set up.

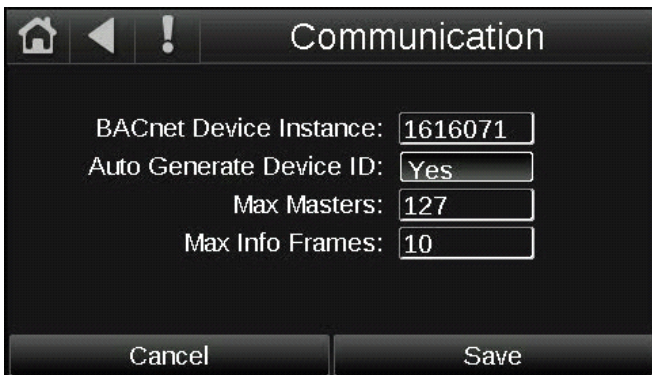

Fig. 44 – Communication

BACnet Device Instance - the unique device address. Must not match any other address, even if on a different bus on the same network. The default Carrier address 1602.

- Auto Generate Device ID:
 - No - the controller will use a user input BACnet ID or the default BACnet ID (1602). See below for manually changing the BACnet Device Instance.
 - Yes - the controller will use the device ID as set by the rotary dials on the controller. The rotary dial addresses will be added to the default BACnet ID (1602).

To manually change the BACnet ID:

1. Press on the box showing the device ID.
2. The keypad will pop up. Use the keypad to enter the new ID.
3. Press done.
4. Press save on the communication screen to save the change.

NOTE: You may need to power cycle the controller before the system will accept the new BACnet ID.

MAX MASTERS

Set this to the highest MAC address (up to 127) on the MS/TP network. If you later add a device with a higher address, this field must be changed to reflect the higher address.

MAX INFO FRAMES

Specifies the maximum number of information messages a controller may transmit before it must pass the token to the next controller.

CAUTION

Increasing this number allows the controller to transmit more messages while it has the token, but it also increases the overall time it takes for the token to pass through the network.

- For a router, set this value to a high number such as 200.
- In non-router controllers, use the following formula to calculate this value: $[2 - (\text{devices} * (.002 + (80/\text{baud})))] / [((600/\text{baud}) * \text{devices})] = \text{Max Info Frames}$ For example, if the network has 15 devices at 19200 baud, Max Info Frames would be 4.

NOTE: It may be necessary to increase the result of the formula for controllers that need to communicate many values to other devices.

Network Router

The network router screen (*Home*→*Set Up*→*Misc Settings*→*BAS Set Up*→*Router*) allows the selection of the communication type and the entry of the router address. See Fig. 45. See Appendix A - BAS Commissioning for more details on BAS set up.

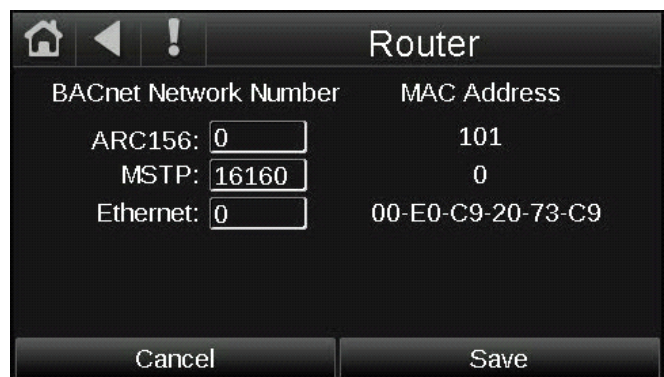

Fig. 45 – Network Router

NOTE: The router address must be box next to the network type being used. The router address next to the network types not being used must be 0.

To change the address:

1. Press on the box next to the network type being used.
2. The keypad will pop up. Use the keypad to enter the router address.
3. Press done.

4. Ensure the box next to the network types not being used is 0.
5. Press save on the router screen to save the change.

NOTE: You may need to power cycle the controller to get the controller to accept the new router address.

IP Settings

The Internet Protocol settings screen (*Home*→*Set Up*→*Misc Settings*→*BAS Set Up*→*IP*) allows the user to view and edit information related to BACnet IP. See Fig. 46. See Appendix A - BAS Commissioning for more details on BAS set up.

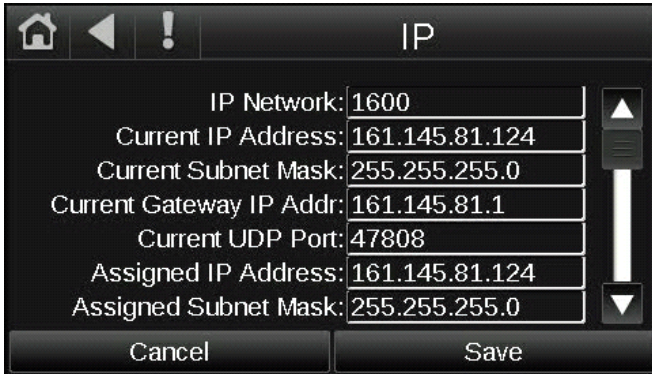

Fig. 46 – IP Settings

Time Master

The Time Master screen (*Home*→*Set Up*→*Misc Settings*→*BAS Set Up*→*Time Master*) allows the user to view and edit information related to a network time master. See Fig. 47. See Appendix A - BAS Commissioning for more details on BAS set up.



Fig. 47 – Time Master

Module Status (Modstat)

The Module Status screen (*Home*→*Set Up*→*Misc Settings*→*Modstat*) allows the user to view information related to the controller, such as program version, driver information, program installation date, and back-up date. See Fig. 48.

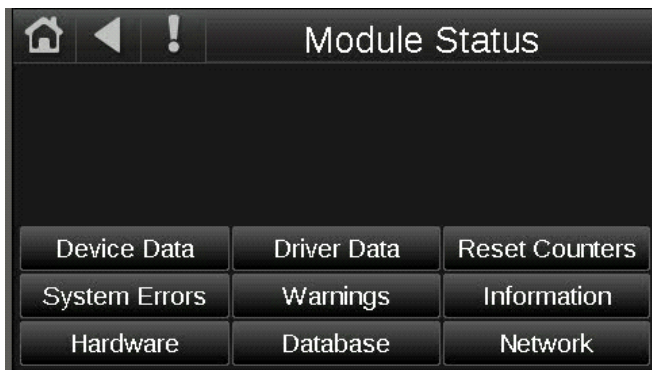

Fig. 48 – Module Status

Information on the modstat screen can be useful for troubleshooting controller or network issues. Contact Carrier technical support for further information when troubleshooting a controller using modstat.

PID Settings

The proportional-integral-derivative settings (*Home*→*Set Up*→*Misc Settings*→*PID settings*) allows the user to view information related to the PID functions that operate some of the modulating components. See Fig. 49.

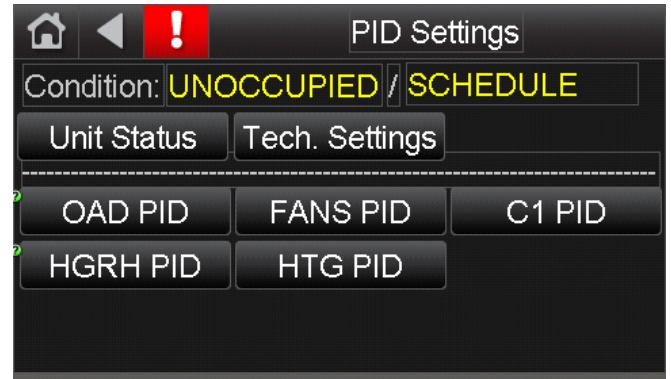

Fig. 49 – PID Settings

NOTE: Carrier does not recommend adjusting the PID settings unless directed to by Carrier technical support.

Equipment Touch Set Up

The touchscreen set up screen (*Home*→*Set Up*→*Misc Settings*→*ET Set Up*) allows the user to adjust settings related to the Equipment Touch operation. See Fig. 50.



Fig. 50 – Equipment Touch Set Up

Consult the Carrier Equipment Touch installation and user guide (11-808-687-01) for details on Equipment Touch settings.

Equipment Configuration

The equipment configuration screen (*Home*→*Set Up*→*Misc Settings*→*Config*) displays the configuration option for each component. See Fig. 51.

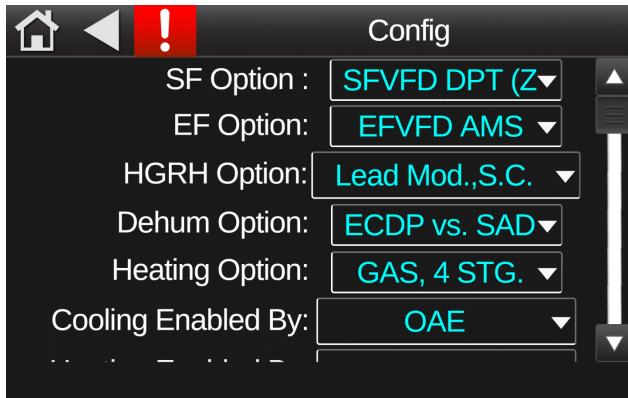

Fig. 51 — Equipment Configuration

The equipment configuration screen shows the configuration by component, which dictates how the unit will be controlled/operated. The parameters on this screen are set by the factory to match the unit order configuration.

NOTE: Changes to the equipment configurations should only be modified by factory trained personnel after consulting with Carrier technical support. Changes to the equipment configuration will affect unit operation and may cause equipment damage or performance issues. Additional components may be required for a change in equipment function to be made. Any changes in these settings will also change the associated set point for the changed component.

Table 8 shows a summary of all possible options. Below is an explanation of some the key options that may need to be field configured.

SF OPTION

Determines how the unit supply fan is controlled. Common configurations include:

- SFVFD AMS - unit has a supply fan airflow measuring station and will modulate the SF to maintain the SF AMS CFM set point.
- SFVFD CAV - SF will operate at constant air volume.
- SFVFD DPT (Zn,Bldg) - unit has zone (building) pressure sensor and will modulate the SF to maintain the zone pressure set point.
- SFVFD DPT (Duct) - unit has a duct pressure sensor and will operate the SF to maintain the duct pressure set point.
- SFVFD ZAT - Not used with 62W units.

EF OPTION

Determines how the unit exhaust fan is controlled. Common configurations include:

- None - no exhaust fan.
- EFVFD AMS - unit has an exhaust fan airflow measuring station and will modulate the EF to maintain the EF AMS CFM set point.
- EFVFD CAV - EF will operate at constant air volume.
- EFVFD DPT (Zn,Bldg) - unit has zone (building) pressure sensor and will modulate the EF to maintain the zone pressure set point.
- EFVFD DPT (Duct) - unit has a duct pressure sensor and will operate the EF to maintain the duct pressure set point.
- EFVFD ZAT - Not used with 62W units.

HGRH OPTION

Determines how the reheat system functions. Should match the unit configuration. Common configurations include:

- Lead - unit has HGRH on the lead circuit.
- Both - unit has HGRH on both circuits.

- Mod - unit has modulating HGRH.
- SC - unit has subcooling reheat before the HGRH.
- By Heating Only - use heat source for reheat. Not used with 62W units.

DEHUM OPTIONS

Determines how dehumidification mode functions (cooling and reheat). Common configurations include:

- OADP/ECDP vs SADP - enables dehum mode when the incoming air dew point is above the supply air dew point set point.
- OAE/ECAE - enables dehum mode when the incoming air enthalpy level is above set point.
- SARH - enables dehum mode when the supply air RH% is above set point.
- ZADP/ZARH - enables dehum mode when the zone air dew point or RH% is above set point.
- MADP/MAE/RARH - Not used with 62W units.

HEATING OPTIONS

Determines how the heating system functions. Should match the unit configuration, unless field installed heat is being added (duct heater).

COOLING ENABLED BY

Determines when cooling mode is enabled. Common configurations include:

- OAE/ECAE - cooling is enabled when the incoming air enthalpy is above set point.
- OAT/ECAT- cooling is enabled when the incoming air temp is above set point.
- OAT/ECAT vs SAT - cooling is enabled when the incoming air temp is above the supply air temp set point.
- RAT/ZAT/None - not for use with 62W units.

HEATING ENABLED BY

Determines when heating mode is enabled. Common configurations include:

- OAT/ECAT - heating mode is enabled when the incoming air is below the heating enable set point.
- OAT/ECAT vs SAT - heating mode is enabled when the incoming air is lower than the SAT set point.
- RAT/ZAT - not for used with 62W units.

TEMP OPTIONS #1

Determine what temperature sensors the 62W supply control will look for. Common configurations include:

- OAT, SAT - for units without ECW. Unit will have outdoor air and supply air temperature sensors.
- OAT, ECAT, SAT - for units with ECW. Unit will have outdoor air, entering coil air (after ECW), and supply air temperature sensors.
- All others - not used with 62W units.

TEMP OPTIONS #2

Determine what temperature sensors the 62W exhaust control will look for. Common configurations include:

- None - for units without ECW.
- WExAT, RAT - for units with ECW. Unit to have wheel exhaust air and return air temp sensors. Used for ECW defrost operation.
- All others - not used with 62W units.

Table 8 – Control Manual Graphics

OPTION	STATUS		OPTION	STATUS	
	VALUE	DISPLAY		VALUE	DISPLAY
SF Option	1	None	Cooling Enabled By	1	OAE
	2	Included		2	OAT
	3	SFVFD AMS		3	OAT and OADP
	4	SFVFD CAV		4	OAT or OAE
	5	SFVFD DPT (ZN, Bldg)		5	OAT/SAT vs SAT
	6	SFVFD DPT (Duct)		6	RAT
	7	SFVFD ZAT		7	ZAT
EF Option	1	None		8	None
	2	Included	Heating Enabled By	1	OAT
	3	EFVFD AMS		2	OAT/SAT vs SAT
	4	EFVFD CAV		3	RAT
	5	EFVFD DPT (ZN, Bldg)		4	ZAT
	6	EFVFD DPT (Duct)		5	None
	7	EFVFD ZAT	Temp Option #1	1	None
HGRH Option	1	Lead On-Off		2	ECAT
	2	Lead On-Off, SC		3	OAT
	3	Lead Mod.		4	SAT ECAT, OAT
	4	Lead Mod., SC		5	ECAT, SAT
	5	Both On-Off		6	OAT, SAT
	6	Both Mod.		7	ECAT, OAT, SAT
	7	By Heating Only	Temp Option #2	1	None
Dehum Option	1	None		2	RAT
	2	ECPD VS SADP SP		3	WExAT
	3	ECAE		4	RAT, WExAT
	4	MADP	Humidity Option #1	1	None
	5	MAE		2	ECRH
	6	OADP vs SADP SP		3	OARH
	7	OAE		4	SARH
	8	RARH		5	ECRH, OARH
	9	SARH		6	ECRH, SARH
	10	ZADP		7	OARH, SARH
	11	Z-RH		8	ECRH, OARH, SARH
Heating Option	1	None	Humidity Option #2	1	None
	2	Elec., 1 Stg		2	RARH
	3	Elec., 2 Stg	Air Pressure Options	1	None
	4	Elec., 3 Stg		2	EF-DPT
	5	Elec., 4 Stg		3	SF-DPT
	6	Elec., SCR		4	ZN-DPT
	7	Gas, 2 STG		5	EF-DPT, SF-DPT
	8	Gas, 4 Stg		6	EF-DPT, ZN-DPT
	9	Gas, 8 Stg		7	SF-DPT, ZN-DPT
	10	Gas, Mod		8	EF, SF, ZN-DPT
	11	Hot Water			
	12	Steam			

HUMIDITY OPTIONS #1 AND #2

Determine what humidity sensors the 62W supply control will look for. Common configurations include:

- OARH, SARH - for units without ECW. Unit will have outdoor air and supply air relative humidity sensors
- ECRH, SARH - for units with ECW. Unit will have entering coil (after ECW), and supply air relative humidity sensors
- All others - not used with 62W units.

AIR PRESSURE OPTIONS

Determine what DPT sensors the 62W control will look for. Common configurations include:

- SF DPT - supply fan differential pressure transmitter (duct)
- ZN DPT - zone (building) differential pressure transducer. Can be used with supply fan or exhaust fan (not both)

- EF DPT - exhaust fan differential pressure transmitter (duct), not used with 62W units.

Archive Program

The program archive screen (*Home*→*Set Up*→*Misc Settings*→*Archive*) displays the control program archive status, archive date, current time and date, and update archive option. See Fig. 52. The controller can store two program archives in memory. One slot is filled upon program installation, which usually occurs in the factory. The second can be filled by a field-initiated archive. Use the Archive screen to check current archive status, current archive date, current archive number, and to archive the program.

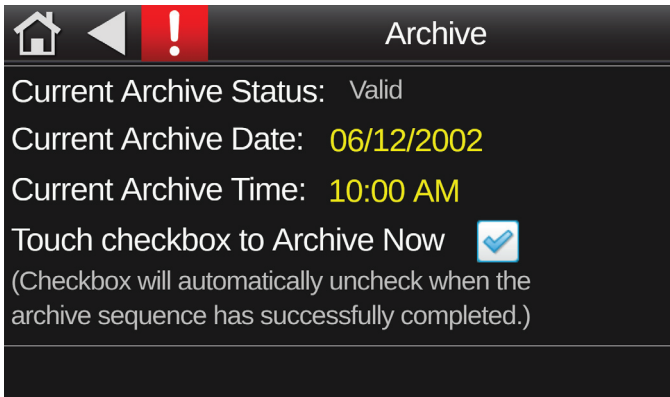

Fig. 52 — Archive Screen

Select the Archive Now checkbox to archive the program. A blue check mark appears in the box to indicate the process is running. The archiving process should take less than 30 seconds to complete. The blue check mark then disappears. Also, the red Archive Valid LED bar (located on the top right corner of the controller) will turn off, then light up when the archive process is complete.

RESTORING FROM ARCHIVE

The controller checks the memory configuration of the program during power up. If the program is identified as corrupt, the controller restores it from the last archive. The LS-1628u controller requires a backup of the current set up when changes are made. This is done through the Equipment Touch 2.

The factory or field archives can also be manually restored in the field.

Creating a Field Archive

To create a field archive (Factory Download File), follow these steps:

It is recommended doing this prior to any Restore and after any Change to controller settings.

1. From the Home screen on the Equipment Touch 2, press the Set Up button. (Factory password will be required.)
2. Press the Misc Set Up button on upper left of layout.
3. Press the Archive button.
4. There will be two check boxes on the Archive screen:
 - a. Backup Memory
 - b. Restore Memory
5. Select the check box on the Backup Memory. Once checked, the backup is automatic and will take about 30 seconds. You will see a date stamp below the check box once complete.
6. You have successfully created a Backup Archive.

Restore Factory Archive

⚠ CAUTION

RESTORING FACTORY ARCHIVE WILL REMOVE ANY/ALL CHANGES FROM CONTROLLER INCLUDING NETWORK/BAS COMMUNICATION SET UP. See Creating a Field Archive before doing a restore.

To restore the factory archive, follow these steps:

1. Power down the controller.
2. Turn the rotary address switches to 8-1-1 (LS-1628u controller has 3 rotary dials for address).
3. Turn on power.
4. SYS led will light blue/white, wait 10 seconds and turn power to controller back off (Communication to EQ2 might show “Loss of Communication” this is normal.)

5. Turn the rotary address back to 0-0-2 or whichever field address is required for communications.
6. Turn power back on. SYS light will flash blue for 30 seconds and then turn green. EQ2 communication will restore and might update depending on archive.

Restore Field Archive

To restore a Field archive (Factory Download File), follow these steps:

We recommend doing this prior to any restore and after any change to controller settings.

1. From the Home screen on the Equipment Touch 2, press the Set Up button. (Factory password will be required.)
2. Press the Misc Set Up button in upper left of layout.
3. Press the Archive button.
4. You will have two check boxes on the Archive screen:
 - a. Backup Memory
 - b. Restore Memory
5. Select the check box on the Restore Memory – once checked, the Restore is automatic and will take about 30 seconds. This can be verified on the SYS LED as it will blink blue. You will see a date stamp below the check box once completed.

NOTE: the first time the controller is restored using Restore check box, the date stamp will show XX/XX/1899, this is normal and will set to current date upon a second Restore.

Test Mode

The test mode screen (*Home*→*Set Up*→*Test*) is a feature that has been added to 62W units with Revision K controls. Test mode can be used during unit start up or troubleshooting. Using the Equipment Touch screen, the user can manually enable a combination of subsystems for a limited amount of time. Each subsystem has its own screen allowing for control and sensor feedback display. See Fig. 53 for the test mode dependency tree.

Test modes include:

- Outdoor Air Damper; Activated with Main Test Mode
- Supply Fan
- Energy Conservation Wheel (in the Test [Cooling] screen)
- Exhaust Fan
- Cooling (DX only)
- Heating (HP and Gas/Elec)
- Hot Gas Reheat
- Sub Cooling

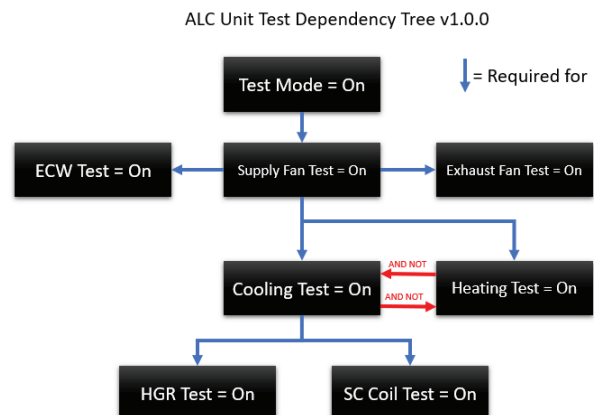

Fig. 53 — Test Mode-Dependency Tree

To access test mode, go to set up, enter user password (1111), and then select Test. Enabling the main test mode will override the occupancy of the unit to unoccupied. The occupancy will revert to the previous value when the main test mode is written OFF or times out. The test menu buttons will reflect the features of the available systems installed in the unit. If the unit model number does not include any given feature, it will not appear in the available test buttons. Once the main test mode is enabled, the outdoor air damper will open to 100% automatically. See Fig. 54.

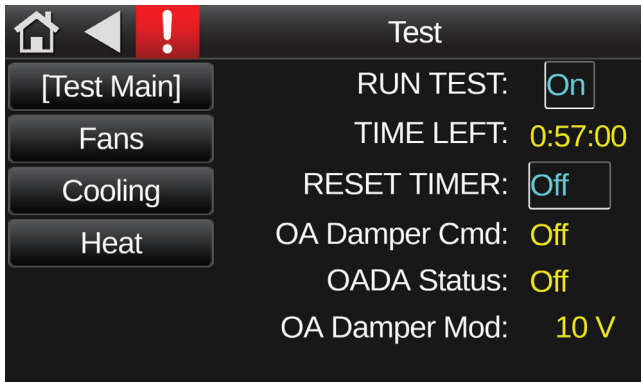

Fig. 54 — Test Mode — Home Screen

SUPPLY FAN TEST MODE

From any of the available test screens, press [Fans] to enter the Test [Fans] screen. The main supply fan can be commanded on by selecting the RUN SF TEST On/Off toggle text. The unit will attempt to turn on the supply fan and wait for confirmation of air proving using the SF-APS (SF-CS on the wiring diagram) input. If the supply fan is modulating, the control will set the speed based on the Supply Fan control variable. This setting is for equipment and property safety. See Fig. 55.

NOTE: If the supply fan fails to prove within 30 seconds of being commanded on, the Main Test Mode will be automatically disabled, and no other tests will be able to run.

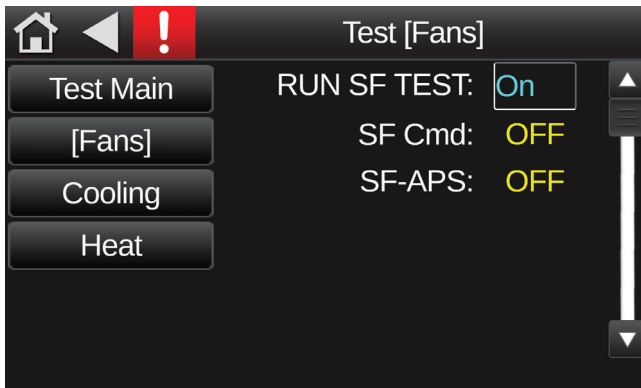

Fig. 55 — Test Mode — Fan Screen

EXHAUST FAN TEST MODE

From any of the available test screens, press [Fans] to enter the Test [Fans] screen. The exhaust fan can be commanded on by selecting the RUN EF TEST On/Off toggle text. The unit will attempt to turn on the exhaust fan and control it to the configured control variable (EF AMS or Zone DPT). The status of the Ex. Fan APS is also displayed.

COOLING TEST MODE

The compressors can be commanded on by selecting the RUN COOL TEST On/Off toggle text. The unit will attempt to turn on the first stage of cooling, then the second stage (dual circuit units only) after a 10 second inter-stage delay. The normal timing checks will be made for LPS, HPS, and HAND ALARM and can take the compressors offline as usual. The Equipment Touch will

display the current switch feedback status of either or both compressors. See Fig. 56.

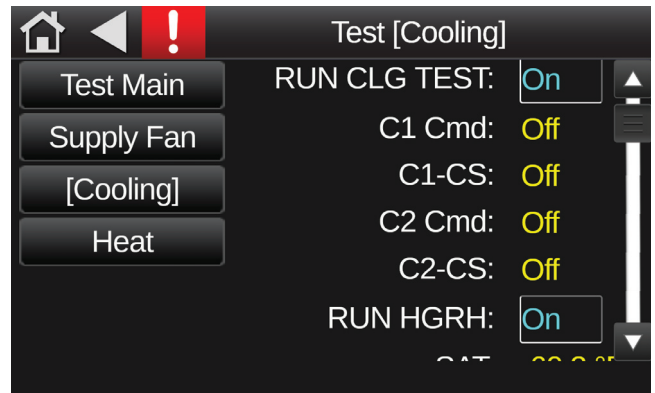

Fig. 56 — Test Mode — Cooling Screen

DEHUMIDIFICATION TEST MODE

Dehumidification test mode can be accessed through the test mode cooling screen. This screen has three dehumidification tests, if the controller indicates they are installed: the Hot Gas Reheat (HGRH) Coil, Subcooling Coil and Energy Conservation Wheel (ECW). Each can be commanded to run by selecting the On/Off toggle text. The unit will attempt to turn on the outputs for each system. The ECW current switch status is displayed for verification. Supply Air Temperature is displayed for HGRH verification.

HEATING TEST MODE

Any available stages of heat can be commanded on by selecting the RUN HEAT TEST On/Off toggle text. The unit will attempt to activate heating via a W1 call from BO-5 on the expansion I/O board. The modulating heat output will ramp to 100% in order to test all stages. If the unit is a heat pump, the reversing valve will be activated along with any modulating heat. After a 10 second delay, compressor 1 will be energized. Following an additional 10 second inter-stage delay, compressor 2 will be energized. The Equipment Touch display will show the Heat Pump commands (if installed) Heat Command, Modulating Heat Command and Supply Air Temperature, for verification of heating. See Fig. 57.

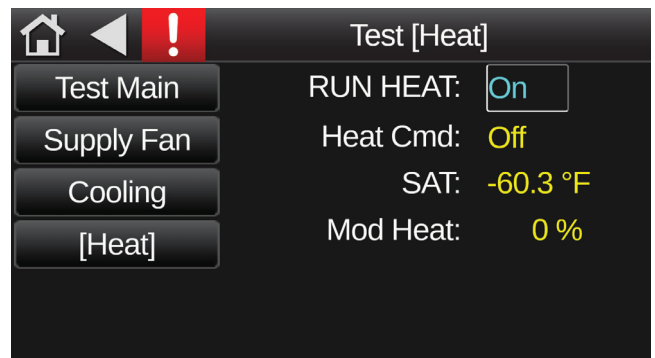

Fig. 57 — Test Mode — Heating Screen

OPERATION

General

See Fig. 58-61 for sequence of operation flow charts. Several options exist for scheduling unit operation, such as the scheduling program built in to the controller (Resident Program Scheduler) or a Building Automation System. The occupancy control source options can be selected from the Equipment Touch™ display pad on the Control Settings screen (requires User or Admin password). The Resident Program has an adjustable scheduler that uses the internal time clock to allow for separate Sequences for Occupied and unoccupied periods. This scheduling function can be accessed from the Equipment Touch display pad on the Schedules screen (requires User password).

NOTE: All temperature related events have an additional 10-second (fixed) delay on make to allow temperatures to settle.

Occupied Mode

- When the program control source calls for the start of the Occupied Mode, and the OEM controller has verified that there are no fault or shutdown conditions, a 30-second (fixed) delay timer begins.
- After the delay time expires, the unit goes into Occupied Mode and the following happens.

OUTDOOR AIR DAMPER (OD)

- After the unit goes into Occupied Mode, the Outdoor Air (OA) damper will open. As the OA damper opens, the OA damper actuator (OADA) auxiliary switches close.
- The OA damper stays open until the system reaches the end of the Occupied Mode period. It will remain open until the supply fan turns off. After the supply fan turns off, the OA damper will close.

SUPPLY FAN (SF)

- As the OA damper opens, the OADA auxiliary switch (adjustable) will close and the SF will turn on.
- The SF shall operate continuously while the unit is in Occupied Mode. When the system reaches the end of the Occupied Mode period, the SF will continue to run for an additional 2 minutes before turning off.
- SF-VSC (Supply Fan with Variable Speed Control): The SF-VSC will modulate its speed based on the SF Differential Pressure Transmitter (SF-DPT) signal to maintain the supply duct static pressure set point. (Optional) For constant air volume (CAV), select “Manual Override” in the Equipment Touch keypad and input the required speed (%) as determined in the field by Test and Balancing.

EXHAUST FAN (EF)

- At the same time the SF turns on, the EF will be enabled to run.
- The EF shall be enabled to run continuously while the unit is in Occupied Mode. When the system reaches the end of the Occupied Mode period, the EF will be enabled to run for an additional 2 minutes before turning off.
- EF-VSC (Exhaust Fan with Variable Speed Control) The EF-VSC will modulate its speed based upon the EFDPT to maintain the building static pressure set point:
 - If the EF-Differential Pressure Transmitter (EF-DPT) signal is above the building static pressure set point, the EF-VSC will modulate its speed based upon the EF-DPT to maintain the set point. If the EF-DPT signal is below the building static pressure set point, the EF will modulate down to 0% (adjustable) speed.
 - (Optional) For constant air volume (CAV), select “Manual Override” in the Equipment Touch keypad and input the required speed (%) as determined in the field by Test and Balancing.

ZAT/SAT SET POINT RESET

- ZAT/SAT Set Point Reset is selectable using the Equipment Touch display pad or Building Automation System (BAS) (default is “OFF”).
- As the ZAT goes above the ZAT cooling set point, the SAT cooling set point will decrease by a ratio (adjustable) in order to lower the ZAT. As the ZAT goes below the ZAT cooling set point, the SAT cooling set point will increase by a ratio (adjustable) in order to raise the ZAT. When the ZAT equals the ZAT cooling set point, the SAT cooling set point will return to the original value.
- As the ZAT goes below the ZAT heating set point, the SAT heating set point will increase by a ratio (adjustable) in order to raise the ZAT. As the ZAT goes above the ZAT heating set point, the SAT heating set point will decrease by a

ratio (adjustable) in order to lower the ZAT. When the ZAT equals the ZAT heating set point, the SAT heating set point will return to the original value.

- Example: A ZAT:SAT ratio of 1:3 means for every 1°F of ZAT increase the SAT set point will decrease by 3°F; maximum -15°F (ZAT = 73°F, SAT = 69°F; ZAT = 74°F, SAT = 66°F; ZAT = 75°F, SAT = 63°F; etc.).

ENERGY CONSERVATION WHEEL (ECW)

- After the OA damper opens and SF turns on, the ECW turns on.
- ECW Standard Operation:
 - When the OAT is 3°F (adjustable) above or below the RAT (return air temperature), the ECW will be on; otherwise it is off.
- ECW with VFD Controlled Defrost (WM-VFD):
 - When the OAT is 3°F (adjustable) above or below the RAT, the ECW will be on. It will be off if the OAT is less than 3°F (adjustable) above or below the RAT. It will decrease speed or stop as the WExAT goes below 25°F (adjustable) to allow for wheel defrosting. It will start back up and increase speed when the WExAT rises toward 25°F (adjustable) or more.

COOLING MODE

- Cooling Mode is available when the Entering Coil Air Temperature (ECAT) is above the ECAT cooling lower limit (55°F, adjustable) and there is a demand for cooling.
- When the Entering Coil Air Temperature (ECAT) is 1°F (adjustable) or more above the Supply Air Temperature (SAT) cooling set point (72°F, adjustable), compressor #1 turns on.
- When the SAT is 2°F (adjustable) or more above the SAT cooling set point (72°F, adjustable), compressor #2 turns on — not less than 10 minutes (adjustable) after compressor #1 turned on.
- When the SAT is 2°F (adjustable) or more below the SAT cooling set point (72°F, adjustable), compressor #2 turns off.
- When the ECAT is 1°F (adjustable) or more below the Supply Air Temperature (SAT) cooling set point (72°F, adjustable), compressor #1 turns off.
- Optional: When enabled, if there is a call for first stage cooling, second stage cooling will be enabled after a 10-minute (adjustable) delay. Both compressors modulate to maintain the cooling set point. Default is OFF.
- Compressor enabling logic includes a 5-minute (fixed) minimum run-time and a 5-minute (fixed) minimum time-off delay to prevent compressor short cycling.
- Variable Speed Compressor (Size 03-55):
 - The controller regulates the capacity of the variable speed lead compressor with a 0-10VDC output signal that controls the VFD’s output to the compressor, resulting in an increase or decrease of the compressor’s motor speed.
 - The variable speed compressor will modulate based upon the Supply Air Temperature (SAT) sensor and set point (70°F, adjustable). The compressor will ramp up to 100% once an hour, for 60 seconds, to push oil back to the compressor.
 - The hot gas reheat circuit and subcooling circuits (if present), will be enabled for the duration of the oil purge.
 - If the DX LAT drops to 38°F or less for 10 minutes, the controller will issue an alarm and the compressor stops. When the DX LAT warms back to 55°F or more, the compressor turns on. If there is a current call for first stage cooling and compressor no. 1 is shut down due to an alarm (HPS1, LPS1, or DX LAT1), compressor no. 2 will be turned on to take its place until it returns.

- Hot Gas Reheat (HGRH) — Modulating:
 - When the SAT is 1°F (adjustable) or more below the SAT cooling set point, HGRH turns on and modulates to maintain the SAT cooling set point.
 - When SAT is 2°F (adjustable) or more above the SAT cooling set point, HGRH turns off.
- Switchable Sub-Cooling:
 - When either of the compressors are enabled during dehumidification mode, the subcooling coil is enabled. When the compressors are disabled, the subcooling coil is disabled.

DEHUMIDIFICATION MODE (FIELD ENABLED)

- Dehumidification Mode is available if the ECAT is 1°F (fixed) above the dehumidification lower limit of 60°F (adjustable) and there is no call for heating.
- When the Entering Coil Air Dew Point (ECDP) is 1°F (adjustable) or more above the Supply Air Dew Point (SADP) set point (55°F, adjustable), Dehumidification Mode is enabled. After the minimum time-off delay, compressor #1 turns on.
- When the ECDP is 2°F (adjustable) or more below the SADP set point, compressor #1 turns off and Dehumidification Mode is disabled.
- HGRH is enabled to operate as necessary to maintain the SAT cooling set point (72°F, adjustable).
- When the SADP is 1°F (adjustable) or more below SADP set point, compressor #2 turns off.
- When ECDP is 2°F (adjustable) or more below the SADP set point, compressor #1 turns off and Dehumidification Mode is disabled.
- Hot Gas Reheat (HGRH) — Modulating:
 - When the SAT is 1°F (adjustable) or more below the SAT cooling set point, HGRH turns on and modulates to maintain the SAT cooling set point.
 - When SAT is 2°F (adjustable) or more above the SAT cooling set point, HGRH turns off.
- Switchable Sub-Cooling:
 - When either of the compressors are enabled and the SAT is equal to or below the SAT cooling set point (72°F, adjustable), the subcooling coil is enabled.
 - When the SAT is 1°F (adjustable) or more above the SAT cooling set point (72°F, adjustable), the subcooling coil is disabled.

HEATING MODE

- Heating Mode is available when the ECAT is below the ECAT heating upper limit (60°F, adjustable) and there is a demand for heating.
- When the ECAT is 1°F (adjustable) or more below the ECAT heating set point (55°F, adjustable), heating is enabled and operates to maintain SAT heating set point (70°F, adjustable).
- When ECAT is 1°F (adjustable) or more above ECAT heating set point (55°F, adjustable), heating is disabled.
- Staged Heat (Electric Heat):
 - 2-Stage Heat: Terminal W1 turning on enables first-stage heating. As SAT goes further below the SAT heating set point (70°F, adjustable), terminal W2 energizes and second-stage heating is enabled. As SAT rises, terminal W2 turns off and second-stage heating turns off. As the SAT goes 1°F (adjustable) or more above the SAT heating set point (70°F, adjustable), terminal W1 turns off and first-stage heating turns off.
 - 4-Stage Heat: Terminal W1 turning on enables the Heating Analog Relay Module (HARM) on the control panel which activates the different stages of heating. As the

SAT goes further below the SAT heating set point (70°F, adjustable), the different stages will turn on. As the SAT goes further above the SAT heating set point (70°F, adjustable), the different stages will turn off.

- Gas Furnace: Terminal W1 turning on energizes the gas furnace controller and first-stage auxiliary heating is enabled. If the SAT is 1°F (adjustable) or more above the SAT heating set point (70°F, adjustable), terminal W1 turns off which de-energizes the gas furnace controller, and first-stage auxiliary heating is turned off. All other stages operate as above.
- Modulated Heat:
 - SCR Electric Heat: On demand for heating, the OEM controller modulates the electric heating SCR in order to maintain the SAT heating set point (70°F, adjustable).
 - Modulating Gas Furnace: On demand for heating, the OEM controller modulates the gas furnace controller to control the gas flow in order to maintain the SAT heating set point (70°F, adjustable).
 - Modulating Hot Water Heat: On demand for heating, the OEM controller modulates the hot water valve to control the hot water flow in order to maintain the SAT heating set point (70°F, adjustable).
 - Modulating Steam Heat: On demand for heating, the OEM controller modulates the steam valve to control the flow of steam in order to maintain the SAT heating set point (70°F, adjustable).

UNOCCUPIED MODE

- When the Occupancy Control indicates the end of the Occupied Mode, the compressor(s) and outdoor fan(s) will turn off (subject to minimum run-time) or the heating system will turn off. The SF and EF will continue to run for 2 minutes before turning off.
- After this, the ECW will turn off and the OA damper will close. The unit is now off.

SAFETY SWITCHES

- High Pressure Switch (HPS1): If HPS1 is open, compressor #1 will turn off and the OEM controller will issue an alarm. After manually resetting HPS1, the HPS1 alarm will reset. Following a minimum time off delay, compressor #1 will turn on. If the OEM controller records 3 high pressure start/restart failure incidents within 1 hour, compressor #1 is locked out and the OEM controller will issue an alarm. The compressor lock-out can be reset in the Equipment Touch display pad or by cycling the power of the OEM controller.
 - This sequence is the same for compressor #2, Y2, and HPS2.
- Low Pressure Switch (LPS1): If LPS1 is open after the LPS1 bypass time, the OEM controller will issue an alarm and compressor #1 turns off. After 30 seconds (fixed), the LPS1 alarm will reset. Following a minimum time off delay, compressor #1 will turn on. If the OEM controller records 3 low pressure start/restart failure incidents within 1 hour, compressor #1 is locked out and the OEM controller will issue an alarm. The compressor lock-out can be reset in the Equipment Touch display pad or by cycling the power of the OEM controller.
 - This sequence is the same for compressor #2, Y2, and LPS2.

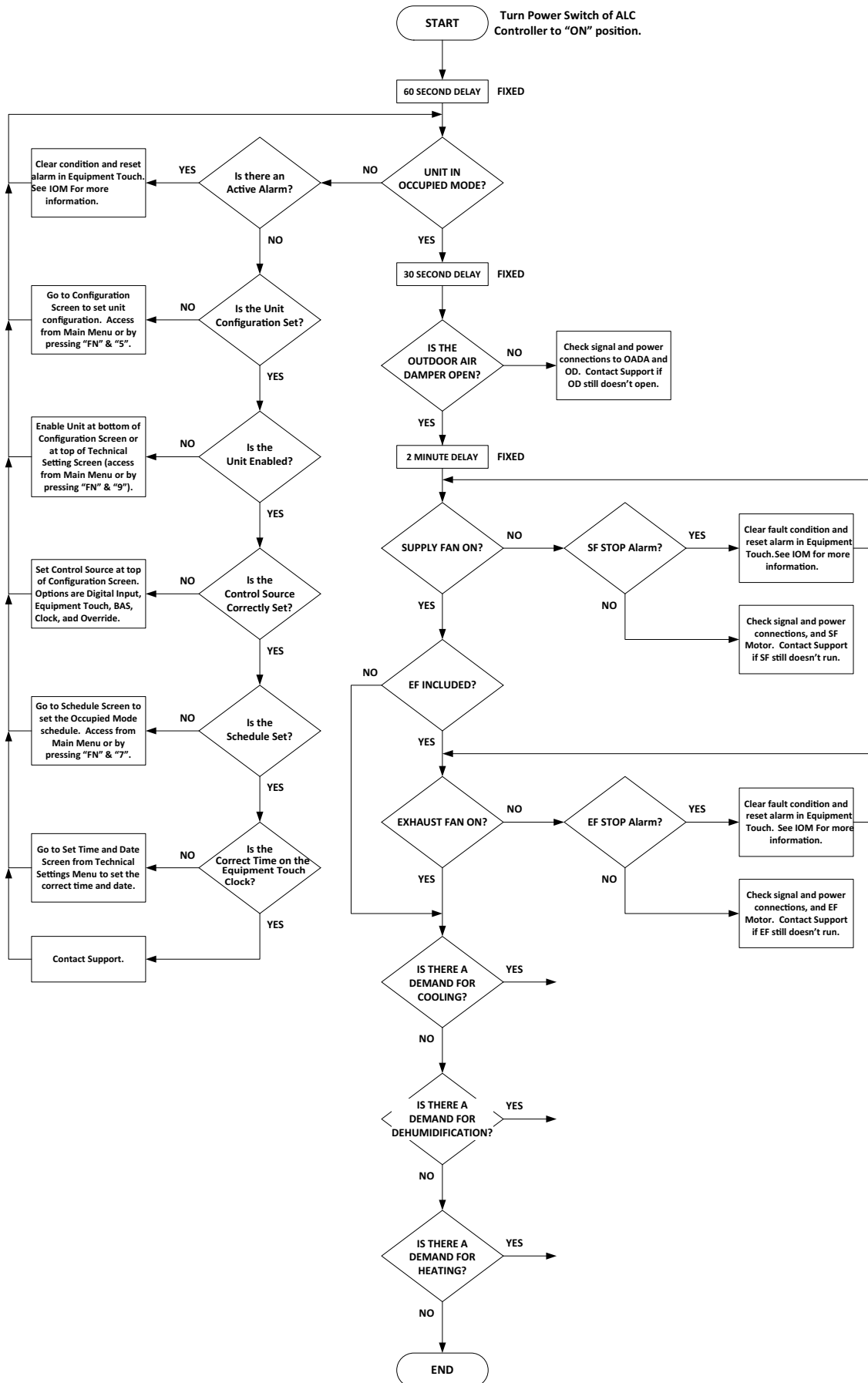

Fig. 58 — 62W Sequence of Operations Flow Chart

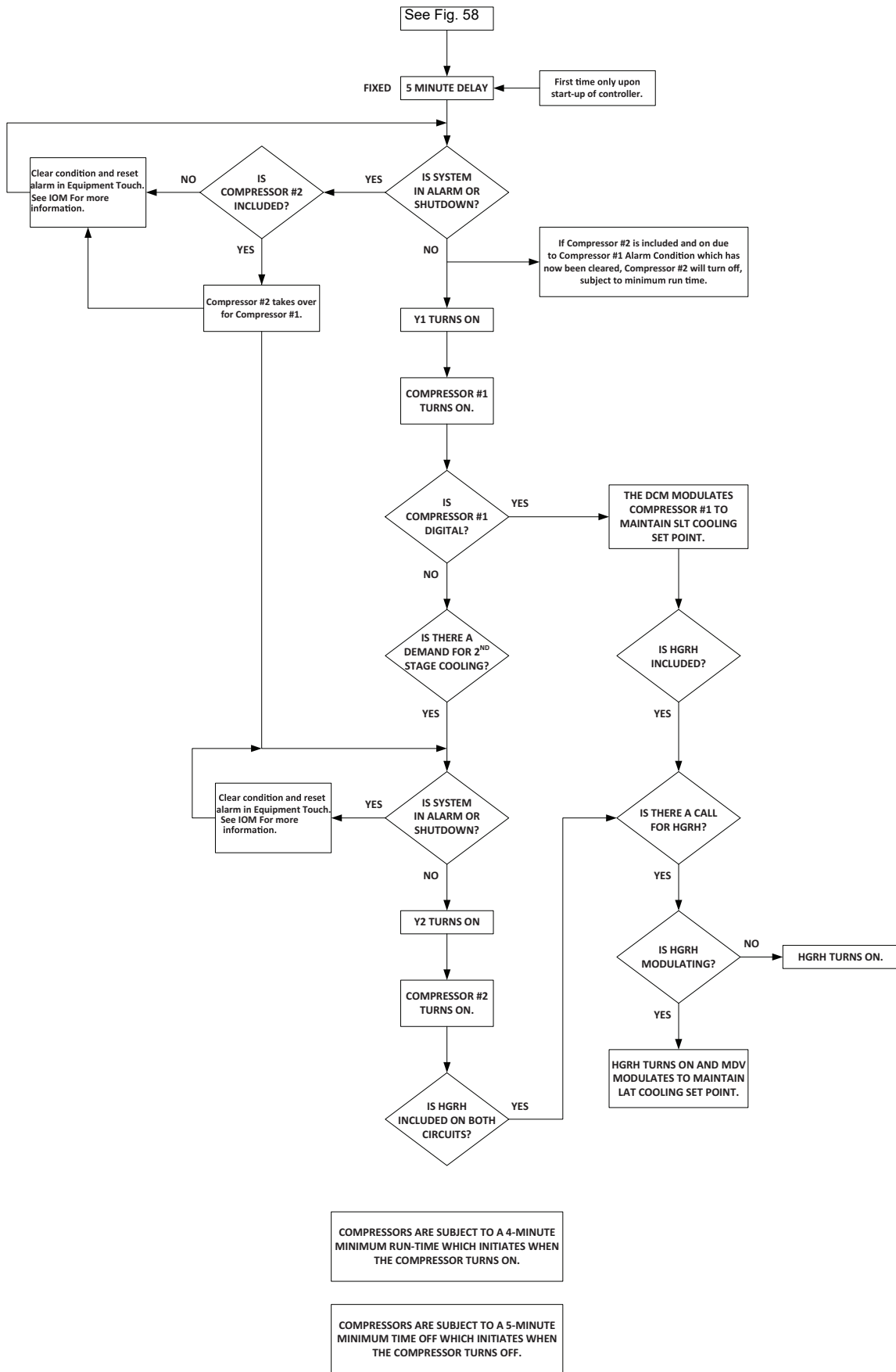

Fig. 59 — 62W Sequence of Operations Flow Chart, Cooling Mode

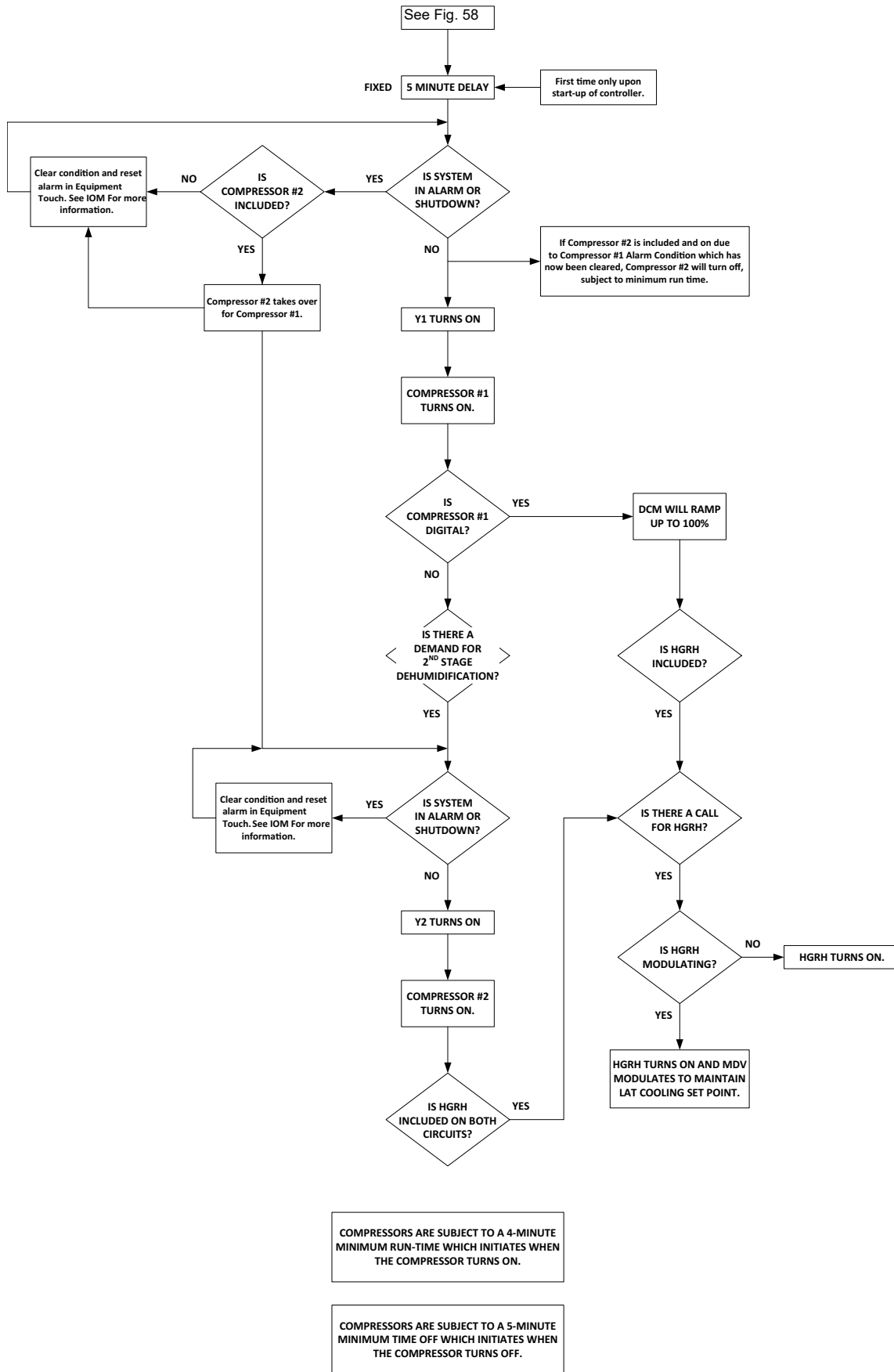

Fig. 60 – 62W Sequence of Operations Flow Chart, Dehumidification Mode

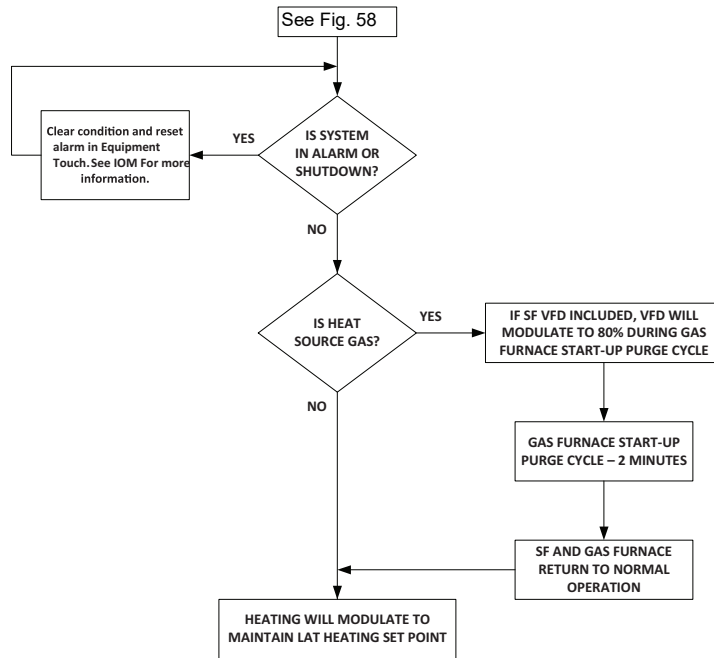

Fig. 61 — 62W Sequence of Operations Flow Chart, Heating Mode

LEGEND FOR FIG. 58-61

- DCM** — Digital Compressor Module
- EF** — Exhaust Fan
- HGRH** — Hot Gas Reheat
- IOM** — Installation and Operation Manual
- LAT** — Leaving Air Temperature
- MDV** — Modulating Discharge Valve
- OADA** — Outdoor Air Damper/Actuator
- OD** — Outside Air Damper
- SF** — Supply Fan
- SLT** — Suction Line Temperature
- VFD** — Variable Frequency Drive

ALARMS

Alarms inform the user that there is an operational problem with the unit. Some alarms will result in the unit shutting down, some will shut down only the affected equipment, and some are informational only. The 100 most recent alarms (active or cleared) can be viewed on the Alarm Status screen on the Equipment Touch device.

Alarm Status

When an alarm is active, the alarm icon (exclamation mark) background on the Home screen is red to indicate an alarm condition. See Fig. 62.

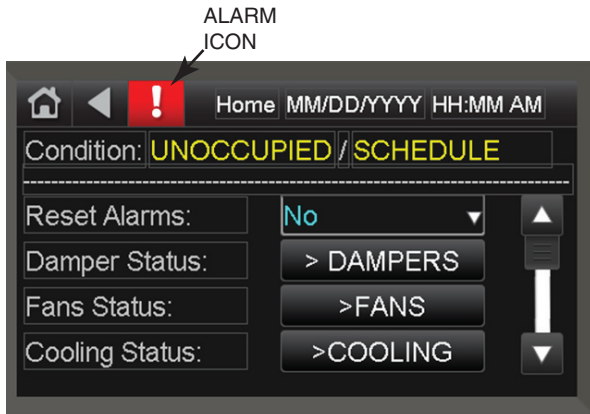

Fig. 62 — Alarm Icon

To access the alarm information, press the red alarm icon on the Home page touchscreen. Press the alarm icon twice to access the Alarms Screen options. See Fig. 63.



Fig. 63 — Alarms Screen

CLEARING ALARMS

When an alarm event occurs, an audible alarm (touchscreen set up option) will sound and the Equipment Touch will log the event on the Active Alarms. Press the alarm icon to display the active alarms list. To access the menu page, press the alarm icon again. Press Clear Active alarms to reset alarms. See Fig. 63.

The alarm will remain active until it is cleared. If the alarm is an automatically re-settable alarm, it will be cleared as soon as the condition which initiated it is corrected. To clear an active alarm press Clear Active.

If an alarm is automatically cleared, it will be removed from the Active Alarms section and moved to the Returned-to-Normal section. If the alarm is manually cleared it will be moved to the Manually Cleared section. Refresh the screen by pressing the Reset Alarms button on the Home screen.

Alarm Matrix

Table 9 lists the possible alarm events which can be displayed in the Alarm Status screen of the Equipment Touch and Table 10 lists the condition/mode statuses which might be displayed to indicate

the Alarm condition/mode of the unit. These are classified as automatically and manually re-settable alarms.

AUTOMATIC RESET

These alarms are reset automatically after the condition which initiated the alarm is corrected. Then they will show up under the Return-to-Normal section of the history. Refresh the screen to see the change. If the condition which initiated the alarm is not corrected, the alarm will be reissued. Table 9 lists the automatic reset alarms.

MANUAL RESET

These alarms are reset manually from the Equipment Touch (see “Clearing Alarms”) or after cycling the power on the OEM. Then they will show up under the “Returned-to-Normal” section of the history. In which case they will show up under the “Manually Cleared” section of the history. If the condition which initiated the alarm is not corrected, the alarm will be reissued. Table 10 lists the manual reset alarms.

ALARMS AFTER START-UP

Alarms may occur after start-up due to a variety of factors. Always check that all sensors and inputs are properly connected.

SAFETY SWITCHES

- High Pressure Switch (HPS1): If HPS1 is open, compressor #1 will turn off and the OEM controller will issue an alarm. After manually resetting HPS1, the HPS1 alarm will reset. Following a minimum time off delay, compressor #1 will turn on. If the OEM controller records 3 high pressure start/restart failure incidents within 1 hour, compressor #1 is locked out and the OEM controller will issue an alarm. The compressor lock-out can be reset in the Equipment Touch or by cycling the power of the OEM controller. Refer to the Installation, Operation and Maintenance (IOM) Instructions for more information.
NOTE: For systems with two circuits, this is the same for compressor #2, Y2 and HPS2.
- Low Pressure Switch (LPS1): If LPS1 is open after the LPS1 bypass time, the OEM controller will issue an alarm and compressor #1 turns off. After 30 seconds (fixed), the LPS1 alarm will reset. Following the minimum time-off delay, the compressor #1 will turn on. If the OEM controller records 3 low pressure start/restart failure incidents within 1 hour, compressor #1 is locked out and the OEM controller will issue an alarm. The compressor lock-out can be reset in the Equipment Touch or by cycling the power of the OEM controller. Refer to the IOM for more information.
NOTE: For systems with two circuits, this is the same for compressor #2, Y2 and LPS2.

SAFETY SHUTDOWN

- Smoke Detector (Optional): When a smoke detector (SD) is provided, it is wired directly to the OEM controller. If smoke is detected, the OEM controller will shut down the unit. The alarm can be reset in the Equipment Touch or by cycling the power of the OEM controller.
- High pressure switch lockout: A compressor fails to start 3 times in an hour due to high pressure switch lock out. The alarm can be reset in the Equipment Touch or by cycling the power of the OEM controller.
- Low pressure switch lockout: A compressor fails to start 3 times in an hour due to low pressure switch lock out. The alarm can be reset in the Equipment Touch or by cycling the power of the OEM controller.
- DX LAT or suction line temperature lock out: A compressor fails to start 3 times in an hour due to DX LAT or suction line temperature lock out. The alarm can be reset in the Equipment Touch or by cycling the power of the OEM controller.
- SAT sensor failure: The OEM controller detects an SAT sensor failure. The alarm can be reset in the Equipment Touch or by cycling the power of the OEM controller.

Table 9 – Automatic Reset Alarm List

ALARM NAME (ALARM STATUS SCREEN)	CONDITION/MODE	DESCRIPTION
Compressor #1 Alarm	Alarm/C1 Alarm	Compressor #1 shut down; CC1-CS shows "Off" but Y1 is "On".
High Pressure Switch #1 Alarm	Alarm/HPS1 Alarm	HPS1 switch open; head pressure high in Comp. #1 circuit.
Low Pressure Switch #1 Alarm	Alarm/LPS1 Alarm	LPS1 switch open; refrigerant pressure low in Comp. #1 circuit
Freeze Protection #1 Alarm	Alarm/FP1 Alarm	DX LAT #1/SLT #1 below the lower freeze set point.
Compressor #2 Alarm	Alarm/C2 Alarm	Compressor #2 shut down; CC2-CS shows "Off" but Y2 is "On".
High Pressure Switch #2 Alarm	Alarm/HPS2 Alarm	HPS1 switch open; head pressure high in Comp. #2 circuit.
Low Pressure Switch #2 Alarm	Alarm/LPS2 Alarm	LPS1 switch open; refrigerant pressure low in Comp. #2 circuit
Freeze Protection #2 Alarm	Alarm/FP2 Alarm	DX LAT #2/SLT #2 below the lower freeze set point.
BAS Comm. Lost Alarm	None	Communication with the BAS has been lost.
Clogged Filter Alarm	Alarm/Cldg Fltr	Clogged filter needs to be changed.
Condensate Overflow Switch Alarm	Alarm/COS Alarm	Condensate overflow switch is open.
Emergency Shutdown Alarm	Alarm/Emer Shtdn	Emergency Shutdown switch (N.C.) is open. Resets when closed.
Freeze Stat Alarm	Alarm/FZT Alarm	Water line freeze stat (N.C.) is open.
Water Flow Switch Alarm	Alarm/WFS Alarm	Water flow switch is open.
Heat Failure	Alarm/Heat Fail	SAT below Heat Fail set point of 50°F after 10 minutes.
High SAT Alarm	Alarm/High SAT	SAT above High SAT Limit set point of 120°F for electric heat or 130°F for gas heat.
Smoke Detector Alarm	Shutdown/SD Stop	Unit shutdown due to Smoke Detector (N.C.) alarm. Resets when Smoke Detector is reset.
DXLAT #1 Sensor Failure	Alarm/Sensr Fail	DX LAT #1 sensor value of -60.2°F or 296°F.
DXLAT #2 Sensor Failure	Alarm/Sensr Fail	DX LAT #2 sensor value of -60.2°F or 296°F.
ECAT Sensor Failure	Alarm/Sensr Fail	ECAT sensor value of -60.2°F or 296°F.
EC-RH Sensor Failure	Alarm/Sensr Fail	EC-RH sensor value of less than 1% or greater than 100%.
MAT Sensor Failure	Alarm/Sensr Fail	MAT sensor value of -60.2°F or 296°F.
MA-RH Sensor Failure	Alarm/Sensr Fail	MA-RH sensor value of less than 1% or greater than 100%.
OAT Sensor Failure	Alarm/Sensr Fail	OAT sensor value of -60.2°F or 296°F.
OA-RH Sensor Failure	Alarm/Sensr Fail	OA-RH sensor value of less than 1% or greater than 100%.
RAT Sensor Failure	Alarm/Sensr Fail	RAT sensor value of -60.2°F or 296°F.
RA-RH Sensor Failure	Alarm/Sensr Fail	RA-RH sensor value of less than 1% or greater than 100%.
SAT Sensor Failure	Alarm/Sensr Fail	Unit shutdown due to SAT sensor value of -60.2°F or 296°F.
SA-RH Sensor Failure	Alarm/Sensr Fail	S A-RH sensor value of less than 1% or greater than 100%.
SLT #1 Sensor Failure	Alarm/Sensr Fail	SLT #1 sensor value of -60.2°F or 296°F.
SLT #2 Sensor Failure	Alarm/Sensr Fail	SLT #2 sensor value of -60.2°F or 296°F.
WExAT Sensor Failure	Alarm/Sensr Fail	WExAT sensor value of -60.2°F or 296°F.
WEx-RH Sensor Failure	Alarm/Sensr Fail	WEx-RH sensor value of less than 1% or greater than 100%.
ZAT Sensor Failure	Alarm/Sensr Fail	Temperature communication fails from the ZS sensor.
Z-RH Sensor Failure	Alarm/Sensr Fail	Humidity communication fails from the ZS sensor.

Table 10 — Manual Reset Alarm List

ALARM NAME (ALARM STATUS SCREEN)	CONDITION/MODE	DESCRIPTION
Compressor #1 Stop	Alarm/C1 Stop	Compressor #1 shut down due to CC1-CS lock out.
High Pressure Switch #1 Stop	Alarm/HPS1 Stop	Compressor #1 shut down due to HPS1 lock out.
Low Pressure Switch #1 Stop	Alarm/LPS1 Stop	Compressor #1 shut down due to LPS1 lock out.
Freeze Protection #1 Stop	Alarm/FP1 Stop	Compressor #1 shut down due to FP1 lock out.
Compressor #1 in HAND Alarm	Alarm/C1 Hand	Comp. #1 in Hand: C1 current sensor shows "On" but Y1 is "Off".
Compressor #2 Stop	Alarm/C2 Stop	Compressor #2 shut down due to CC2-CS lock out.
High Pressure Switch #2 Stop	Alarm/HPS2 Stop	Compressor #2 shut down due to HPS2 lock out.
Low Pressure Switch #2 Stop	Alarm/LPS2 Stop	Compressor #2 shut down due to LPS2 lock out.
Freeze Protection #2 Stop	Alarm/FP2 Stop	Compressor #2 shut down due to FP2 lock out.
Compressor #2 in HAND Alarm	Alarm/C2 Hand	Comp. #2 in Hand: C2 current sensor shows "On" but Y2 is "Off".
Exhaust Fan Alarm	Alarm/EF Stop	Exhaust Fan Failure; EF commanded on and EF-APS/CS shows no airflow or current.
Exhaust Fan in HAND Alarm	Alarm/EF Hand	Exhaust Fan in Hand; EF commanded off and EF-APS/CS shows airflow or current.
Supply Fan Alarm	Shutdown/SF Stop	Unit shutdown due to Supply Fan failure; SF commanded on and SF-APS/CS shows no airflow or current.
Supply Fan in HAND Alarm	Shutdown/SF Hand	Supply Fan in Hand; SF commanded off and SF-APS/CS shows airflow or current.
High Supply Duct Pressure Stop	Shutdown/High SFDPT	Unit shutdown; SF-DPT indicates supply duct static pressure over limit.
Low SAT Alarm	Shutdown/Low SAT	Unit shutdown due to SAT below low limit set point 40°F.
SAT Sensor Failure	Shutdown/SAT Stop	Unit shutdown due to SAT sensor value of -60.2°F or 296°F.

SENSORS

See Table 11 for a list of all sensors.

Table 11 — Sensor List

NAME	DESCRIPTION	FACTORY INSTALLED	REPLACEMENT COMPONENT PART NUMBER
OAT/RH	Outside air temperature and RH Sensor (when ERV not included)	Yes	0843P-0587
ECAT/RH	Entering coil air temperature and RH sensor (used in place of OAT/RH when ERV ordered)	Yes	0843P-0587
SAT/RH	Supply air temperature and RH sensor	No (Yes on units with no heat)	0843P-0586
OAT/RH	Outside air and return air temperature and RH Sensor (when ERV included)	Yes	0843P-0583
WExAT	Wheel exhaust air temperature sensor (when ERV with VFD defrost included)	Yes	0843P-0583
ZS	Zone air temperature sensor (optional)	No	ZS2-CAR
DX LAT1	DX coil leaving air temperature (single stage)	Yes	0843P-0619
DX LAT2	DX coil leaving air temperature (dual stage)	Yes	0843P-0619
SF-DPT	Supply duct pressure transducer (optional)	No	0844P-0153
EF-DPT	Exhaust space pressure transducer (optional)	No	0844P-0154
AMS	Air monitoring station (optional)	Yes	0843P-0593
SF-APS	Supply fan air proving switch	Yes	844P-0155
EF-APS	Exhaust fan air proving switch	Yes	0844P-0155
WM-CS	Wheel motor current switch	Yes	0874P-0187
CC1-CS	Cooling circuit current sensor first stage	Yes	0874P-0187
HPS1	High pressure switch first stage	Yes	0844P-0177
LPS1	Low pressure switch first stage	Yes	0844P-0178
CC2-CS	Cooling circuit current sensor second stage	Yes	0874P-0187
HPS2	High pressure switch second stage	Yes	0844P-0146
LPS2	Low pressure switch second stage	Yes	0844P-0151
CFI	Clogged filter indicator	Yes	0334N-0001A
AMS	Airflow monitoring station	Yes	0843P-0593
SD	Smoke Detector (Duct Mount)	No	0845P-0057
COS	Condensate Overflow Switch	Yes	0843P-0558
CO2	CO ₂ Sensor (Duct Mount)	No	0844N-0049A
A2LGS1	A2L refrigerant leak detection sensor (compressor compartment)	Yes	Consult Factory
A2LGS2	A2L refrigerant leak detection sensor (DX indoor coil compartment)	Yes	Consult Factory

Zone Air Temperature Sensor (Carrier ZS2)

The Carrier ZS2 Rnet zone air temperature sensor is used for applications requiring SAT reset based on ZAT. See SAT Reset for details. A ZAT sensor is not required for 62W operation. If a ZAT sensor is required, it must be field-supplied and installed. The Rnet communication wire (4 conductor) should be wired to the Rnet Communication Port on the OEMCtrl OptiCORE LS-1628u controller. The shield wire and ground wire should be inserted into the controller's GND terminal. Do not mount the sensor in the same electrical box with line voltage devices. Mount the sensor 5 ft from the floor. Do not mount the sensor near any doors, windows, supply air diffusers, or other air disturbances. See Table 12 for ZAT specifications. See Fig. 64 for ZAT mounting specifications.

Table 12 — Zone Air Temperature Sensor

SENSOR NAME	ZS2 Space Temperature Sensor (same as Carrier ZS sensor)
SENSOR TYPE	Precision Thermistor. Standard accuracy $\pm 0.45^\circ\text{F}$ (0.25°C). Less than $\pm 0.18^\circ\text{F}$ (0.1°C) drift over a 10-year period
SENSOR RANGE	$50^\circ\text{F} - 95^\circ\text{F}$ ($10^\circ\text{C} - 35^\circ\text{C}$).
POWER	Supplied by the 4-conductor cable (+12 vdc at 210 mA) from the controller.
COMMUNICATION	115 kbps
ACCESS PORT	Local Rnet Port, for local access to start up and troubleshoot system
OPERATING RANGE	$32-122^\circ\text{F}$ ($0-50^\circ\text{C}$), 10-90% relative humidity, non-condensing
MOUNTING	Standard 4 x 2-in. electrical box using provided 6-32 by 1/2 in. mounting screws.
WIRE	Shielded 4 conductor plenum rated, CMP, 18-22 AWG. Maximum 500 ft
DIMENSIONS	Width: 2-3/4 in. Height: 4-3/4 in. Depth: 5/8 in.

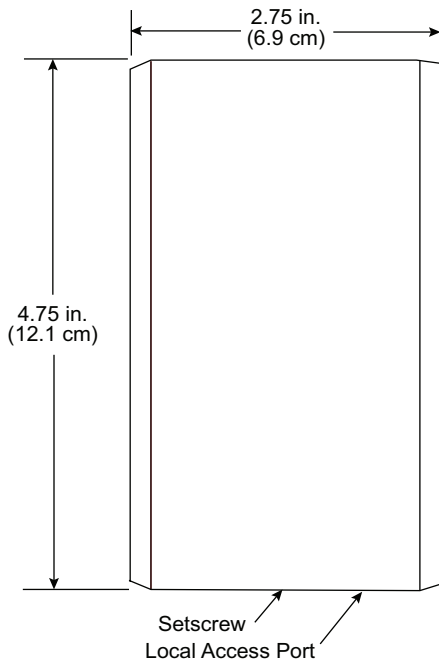

Fig. 64 — Zone Air Temperature Sensor Details

INSTALLATION

1. Verify wall or outlet box has been installed.
2. Turn off controller power.
3. Pull the back plate off the ZS sensor. The setscrew in the bottom of the sensor may need to be turned clockwise until the back plate can be removed.

4. Pull the Rnet communication cable through the wire guide in the back plate.
5. Use 2 screws to mount the back plate to the wall or outlet box. See Fig. 65.

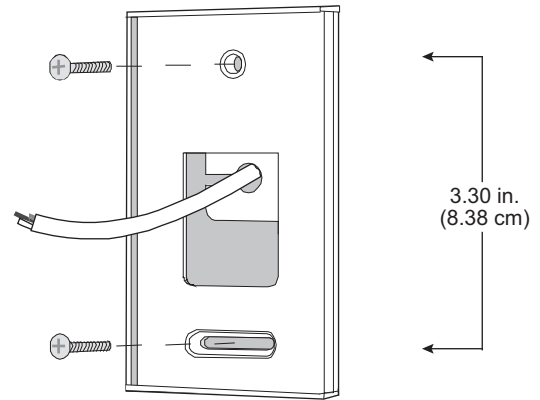

Fig. 65 — Rnet Cable Installation

6. Partially cut, then bend and pull off the outer jacket of the Rnet cable(s). Do not nick the inner insulation.
7. Strip about 0.25 in. (0.6 cm) of the inner insulation from each wire. See Fig. 66.

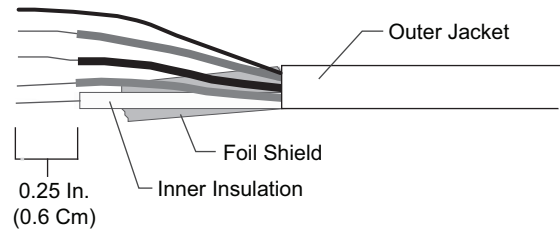
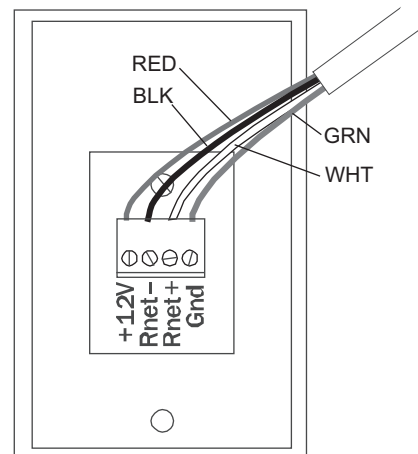

Fig. 66 — Rnet Cable

8. Cut the shield wire off at the outer jacket and then wrap the cable with tape at the outer jacket to cover the end of the shield wire.
9. Insert the other 4 wires into the ZS sensor's screw terminal connector. See Fig. 67.



THE FOLLOWING WIRE SCHEME IS RECOMMENDED:

CONNECT THIS WIRE...	TO THIS TERMINAL...
Red	+12V
Black	Rnet-
White	Rnet+
Green	Gnd

Fig. 67 — Rnet Terminal Connections

CAUTION

Allow no more than 0.06 in. (1.5 mm) bare communication wire to protrude. If bare communication wire contacts the cable's foil shield, shield wire, or a metal surface other than the terminal block, the sensor may not communicate correctly which could cause unit damage. See Fig. 68.

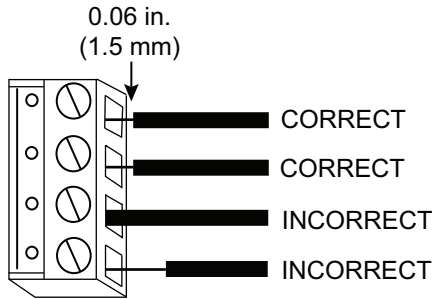

Fig. 68 – Proper Wire Positioning

10. Attach the sensor's cover and circuit board to the mounted back plate, inserting the top first.
11. Turn the setscrew one full turn counterclockwise so that the cover cannot be removed.

NOTE: Use the same polarity throughout the Rnet communication port on the controller. See Table 13 for troubleshooting.

Table 13 – ZAT Troubleshooting

IF THE LED ON THE BACK OF THE CIRCUIT BOARD...	THEN THE SENSOR...
IS NOT LIT	Has no power
BLINKS 1 TIME PER SECOND	Has no communication.
BLINKS 2.5 TIMES PER SECOND	Is communicating properly

Multiple ZS Sensors-Wiring and Set Up

See Fig. 69.

- Standard programming can accept up to (5) ZS sensors.
- Room Sensors must be wired in a “daisy chain” configuration. See Fig. 69.
- It is necessary to set up a unique address for each sensor between 0 and 4.
- The first sensor should be set at address “0” by leaving all dip switches off.
- The second sensor should be set at address “1” by turning dip switch “1” on.
- The third sensor should be set at address “2” by turning dip switch “2” on.
- The fourth sensor should be set at address “3” by turning dip switches “1” and “2” on.

NOTE: Use #18g shielded 4-wire on all ZS sensor connections. terminate shielded wire at “gnd” terminal block located on the electrical panel.

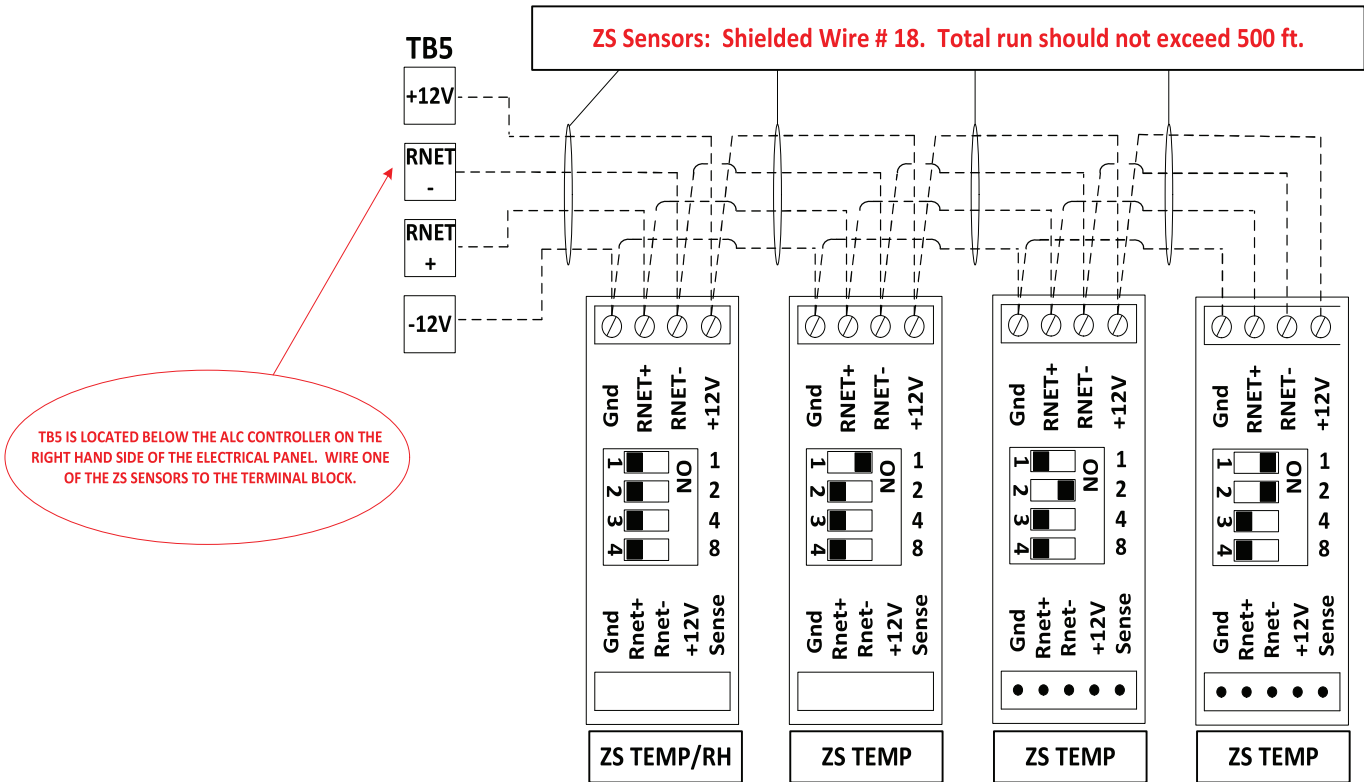

Fig. 69 – ZS Sensors –Wiring and Set Up

Supply Air Temperature and Relative Humidity Sensor (SAT/RH)

All 62W units require a SAT/RH sensor for operation. See Table 14 for sensor details. On 62W units with a factory installed heater, the SAT/RH sensor ships in the control enclosure for field mounting, wiring, and installation on the supply duct work. See below for installation instructions and see Fig. 70 for sensor dimensions. The SAT/RH sensor should be installed at least 10 feet away from the unit, to ensure a proper reading.

On units without factory installed heat, the SAT/RH sensor is factory installed.

NOTE: If a field provided duct heat source is used, the factory SAT/RH sensor must be located to at least 10 feet downstream of the heat source.

The SAT/RH sensor requires four conductors. Two conductors are connected to UI-3 for the SAT sensor input. See Table 15 for thermistor resistance readings. The other two conductors are used to for the SARH sensor power (24V can be taken from TB-A) and the output, which is connected to the UI-4 input on the OEMCtrl OptiCORE LS-1628u controller. See Fig. 70 for SAT/RH sensor and controller wiring details.

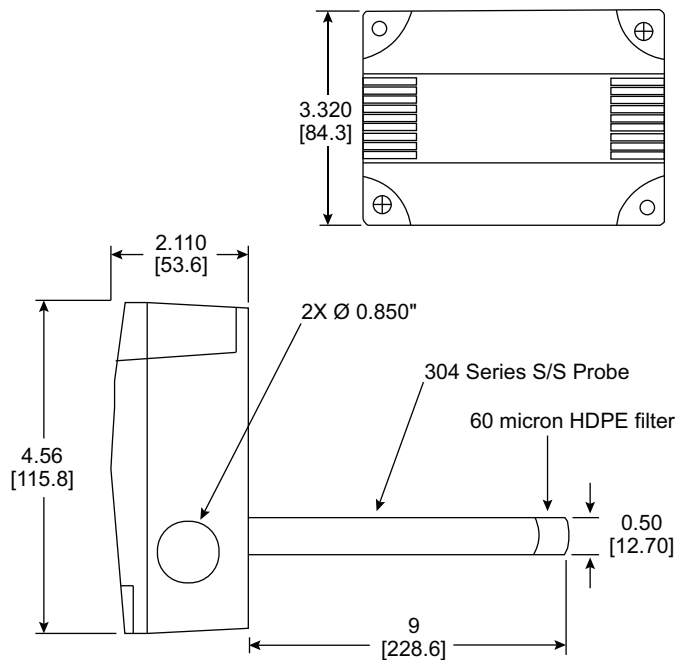

NOTE(S):
Dimensions in in. [mm]

Fig. 70 — SAT/RH Sensor Dimensions

Table 14 — Sensor

SENSOR NAME	Greystone/ACI RH200A Duct Temperature and Relative Humidity Transmitter
FACTORY PART NUMBER	0843P-0586
SENSOR TYPE	Temperature: Thermistor, 10KΩ (at 77°F) Humidity: Thermoset Polymer Capacitive
SENSOR RANGE	Temperature: -4 to 221°F Humidity: 0 to 100%
OPERATING RANGE	-40 to 185°F
OUTPUT SIGNAL	Temperature: Resistive Humidity: 0 to 10V
POWER SUPPLY	18 to 30 VDC, 15 to 26 VAC
PROBE DIMENSIONS	9 in. long, 5 in. diameter
WIRE SIZE	14-22 AWG

SAT/RH SENSOR INSTALLATION

SENSOR MOUNTING

- The transmitter installs directly into any air duct with a minimum width/diameter of 10 inches.
- Select a suitable installation area in the middle of the duct wall.
 - To achieve the best reading, do not place in an area where air stratification may be present.
 - Mount the sensor at least 5 foot in either direction from elbows, dampers, filters or other duct restrictions.
 - Avoid areas where the transmitter is exposed to vibrations or rapid temperature changes.
- Once a suitable spot is selected, drill a 0.6 in. to 0.75 in. hole for the probe.
- Slide the probe in the drilled hole until the enclosure is flush against the duct.
 - The airflow direction is not important.
 - A foam gasket on the back of the enclosure provides a seal against air leaks.
- Secure the enclosure to the duct with (2) #10 x 1 in. self-tapping screws (Not provided).
- Tighten screws until the enclosure is tight against the duct and that there is no movement of the enclosure

SENSOR WIRING AND CONFIGURATION

- Using a Phillips screwdriver, remove the (2) screws holding the cover on the sensor
- Remove cover and set aside with screws for re-installing after wiring and set up.
- Two 0.8125 in. holes are provided for connection of either 0.5 in. EMT or a cable gland style connector
- Insert the EMT or cable gland connector through the hole and securely fasten using a locknut.
 - If only one connection hole is required, use the included hole cap to cap the unused opening.
- Special care must be taken not to damage any internal components during installation.
- Deactivate the 24 VAC/DC power supply until all connections are made to the device to prevent electrical shock or equipment
- Use 14-22 AWG shielded wiring for all wiring connections
 - Do not locate the device wires in the same conduit with wiring used to supply inductive loads such as motors.
 - The humidity and temperature connections can be made using a single, multi conductor, shielded cable if desired.
 - Make all connections in accordance with national and local codes.
- Pull at least six inches of wire into the enclosure, then complete the wiring connection per Fig. 71.
- Connect the DC positive or the AC voltage hot side to the PWR terminal.
 - For voltage output or AC power, the supply Common is connected to the COM terminal.
 - The device is reverse voltage protected and will not operate if connected backwards.
- The analog output is available on the OUT terminal. Check the controller Analog Input to determine the proper connection before applying power as shown in Fig. 71.
- The resistance temperature output is available on the two terminals labeled TEMPERATURE SENSOR as shown in Fig. 71.

- A jumper may be used between the TEMPERATURE SENSOR and COM to reduce the number of needed conductors.

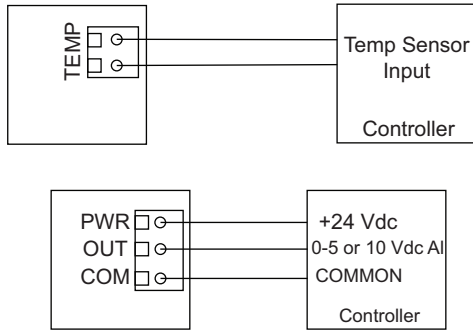

Fig. 71 – SAT/RH Sensor Wiring

- Verify that the sensor is set to provide a voltage output and the output voltage is set for 10V. See Fig. 72.

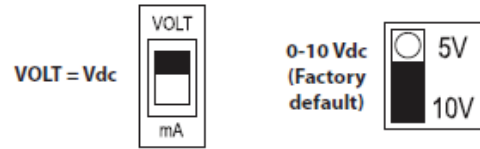

Fig. 72 – SAT/RH Configuration

- Once wiring and set up are complete, re-install cover and tighten the (2) screws using a Phillips screwdriver.

CONTROLLER WIRING AND CONFIGURATION

- Verify that the controller power and 24V power are disabled
- Make the appropriate wiring connections at the controller. See Fig. 73.
- The setting for the inputs are done in the program, no jumpers or settings on board are required

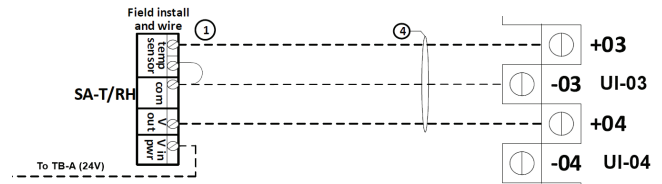

Fig. 73 – SAT/RH Controller Wiring

Table 15 — Thermistor Resistance vs. Temperature

TEMP (°C)	RESISTANCE (Ohms)	TEMP (°F)	TEMP (°C)	RESISTANCE (Ohms)	TEMP (°F)	TEMP (°C)	RESISTANCE (Ohms)	TEMP (°F)
-40.0	337,200	-40.0	14.0	16,470	57.2	68.0	1,878	154.4
-39.0	315,500	-38.2	15.0	15,710	59.0	69.0	1,814	156.2
-38.0	295,400	-36.4	16.0	15,000	60.8	70.0	1,753	158.0
-37.0	276,700	-34.6	17.0	14,320	62.6	71.0	1,695	159.8
-36.0	259,300	-32.8	18.0	13,680	64.4	72.0	1,638	161.6
-35.0	243,100	-31.0	19.0	13,070	66.2	73.0	1,584	163.4
-34.0	228,000	-29.2	20.0	12,490	68.0	74.0	1,532	165.2
-33.0	213,900	-27.4	21.0	11,940	69.8	75.0	1,482	167.0
-32.0	200,800	-25.6	22.0	11,420	71.6	76.0	1,433	168.8
-31.0	188,600	-23.8	23.0	10,920	73.4	77.0	1,387	170.6
-30.0	177,200	-22.0	24.0	10,450	75.2	78.0	1,342	172.4
-29.0	166,500	-20.2	25.0	10,000	77.0	79.0	1,299	174.2
-28.0	156,600	-18.4	26.0	9,572	78.8	80.0	1,258	176.0
-27.0	147,300	-16.6	27.0	9,165	80.6	81.0	1,218	177.8
-26.0	138,600	-14.8	28.0	8,777	82.4	82.0	1,179	179.6
-25.0	130,500	-13.0	29.0	8,408	84.2	83.0	1,142	181.4
-24.0	122,900	-11.2	30.0	8,056	86.0	84.0	1,106	183.2
-23.0	115,800	-9.4	31.0	7,721	87.8	85.0	1,072	185.0
-22.0	109,200	-7.6	32.0	7,402	89.6	86.0	1,039	186.8
-21.0	103,000	-5.8	33.0	7,098	91.4	87.0	1,007	188.6
-20.0	97,130	-4.0	34.0	6,808	93.2	88.0	975.9	190.4
-19.0	91,660	-2.2	35.0	6,531	95.0	89.0	946.1	192.2
-18.0	86,540	-0.4	36.0	6,267	96.8	90.0	917.4	194.0
-17.0	81,730	1.4	37.0	6,015	98.6	91.0	889.7	195.8
-16.0	77,220	3.2	38.0	5,774	100.4	92.0	863.0	197.6
-15.0	72,980	5.0	39.0	5,545	102.2	93.0	837.2	199.4
-14.0	69,000	6.8	40.0	5,326	104.0	94.0	812.3	201.2
-13.0	65,260	8.6	41.0	5,116	105.8	95.0	788.2	203.0
-12.0	61,750	10.4	42.0	4,916	107.6	96.0	765.0	204.8
-11.0	58,450	12.2	43.0	4,725	109.4	97.0	742.6	206.6
-10.0	55,340	14.0	44.0	4,543	111.2	98.0	720.9	208.4
-9.0	52,420	15.8	45.0	4,368	113.0	99.0	700.0	210.2
-8.0	49,670	17.6	46.0	4,201	114.8	100.0	679.8	212.0
-7.0	47,080	19.4	47.0	4,041	116.6	101.0	660.2	213.8
-6.0	44,640	21.2	48.0	3,888	118.4	102.0	641.3	215.6
-5.0	42,340	23.0	49.0	3,742	120.2	103.0	623.1	217.4
-4.0	40,170	24.8	50.0	3,602	122.0	104.0	605.4	219.2
-3.0	38,120	26.6	51.0	3,468	123.8	105.0	588.4	221.0
-2.0	36,200	28.4	52.0	3,340	125.6	106.0	571.9	222.8
-1.0	34,380	30.2	53.0	3,217	127.4	107.0	555.9	224.6
0.0	32,660	32.0	54.0	3,099	129.2	108.0	540.4	226.4
1.0	31,040	33.8	55.0	2,987	131.0	109.0	525.5	228.2
2.0	29,510	35.6	56.0	2,878	132.8	110.0	511.0	230.0
3.0	28,060	37.4	57.0	2,775	134.6	111.0	497.0	231.8
4.0	26,690	39.2	58.0	2,675	136.4	112.0	483.5	233.6
5.0	25,400	41.0	59.0	2,580	138.2	113.0	470.4	235.4
6.0	24,180	42.8	60.0	2,489	140.0	114.0	457.7	237.2
7.0	23,020	44.6	61.0	2,401	141.8	115.0	445.4	239.0
8.0	21,920	46.4	62.0	2,317	143.6	116.0	433.5	240.8
9.0	20,890	48.2	63.0	2,236	145.4	117.0	421.9	242.6
10.0	19,900	50.0	64.0	2,158	147.2	118.0	410.8	244.4
11.0	18,970	51.8	65.0	2,084	149.0	119.0	399.9	246.2
12.0	18,090	53.6	66.0	2,012	150.8	120.0	389.4	248.0
13.0	17,260	55.4	67.0	1,944	152.6			

Differential Pressure Transmitter (DPT)

Units with the factory installed pressure control option will include one (units without exhaust fan) or two (units with exhaust fans) DPTs to allow variable speed fan control. The supply fan DPT is typically used for duct pressure control and the exhaust fan DPT is typically used for space pressure control.

The DPT are factory supplied for units with the pressure control option (ship in control box) and require field installation. The DPTs can be installed in the control box with pneumatic tubing run to the pressure pick up location or can be installed at the pick-up location with wiring run back to the unit. A field supplied pressure pick up probe is recommended. See Fig. 74 and Table 16 for DPT details. See the following installation details.

Table 16 – Differential Pressure Transmitter

SENSOR NAME	ACI DPT
POWER	16-36 VDC
OUTPUT	0-5/0-10 VDC Field Selectable
PRESSURE RANGE	0-10 in. (supply), 0-1 in. (exhaust)
OPERATING TEMPERATURE RANGE	32 to 122°F (0 to 50°C)
ACCURACY	± .5%
OPERATING RH	10-95%, non-condensing
WIRE	Finger Pushbutton (spring) Terminal Blocks; accepts 16-24 AWG wires
PRESSURE FITTING	Nickel plated brass or stainless steel; 1/4 in. OD x.17 in. ID poly tubing
OVERALL DIMENSIONS	Width: 4.25 in. Height: 6.125 in. Depth: 2.25 in.

INSTALLATION

1. Turn off controller power.
2. Connect the DPT wiring to the controller. See Fig. 75.

- a. Connect the com wire to controller terminal 10 (ground) on UI-10 (Supply Pressure) or terminal 11 (ground) on UI-11 (Exhaust Pressure).
- b. Connect the power wire (EXC) wire to the controller +24VDC power supply.
- c. Connect the out wire to controller terminal 10 (positive) on UI-10 (Supply Pressure) or controller terminal 11 (positive) on UI-11 (Exhaust Pressure).
3. Mount the DPT sensor in the desired location, using 2 field-provided screws. The unit must be in the vertical position.
4. Open the side panel of the DPT sensor.
5. Pull the wire through the wire guide on the bottom of the sensor.
6. Remove the terminal block from the sensor, and attach the wires to the corresponding terminals.
7. Reinstall the terminal block.
8. Verify the adjustment switches are in the correct position:
 - a. Range Switch: 0-2 in. is recommended for duct pressure control, 0-.1in. for space pressure control.
 - b. Directional Jumper: unidirectional for supply, bidirectional for return
 - c. Output Switch: Voltage
 - d. Output Range Jumper: 10V
9. Restore power to the controller and DPT sensor.
10. Leaving the pressure tubing disconnect, press the Zero button for 5 seconds to zero the sensor.
11. Install the pressure tubing to the Hi side of the sensor (for supply) or low side of the sensor (for exhaust).
12. Install the other end of the pressure tubing to the ductwork, using an approved probe device.



Fig. 74 – 62W DPT Dimensions

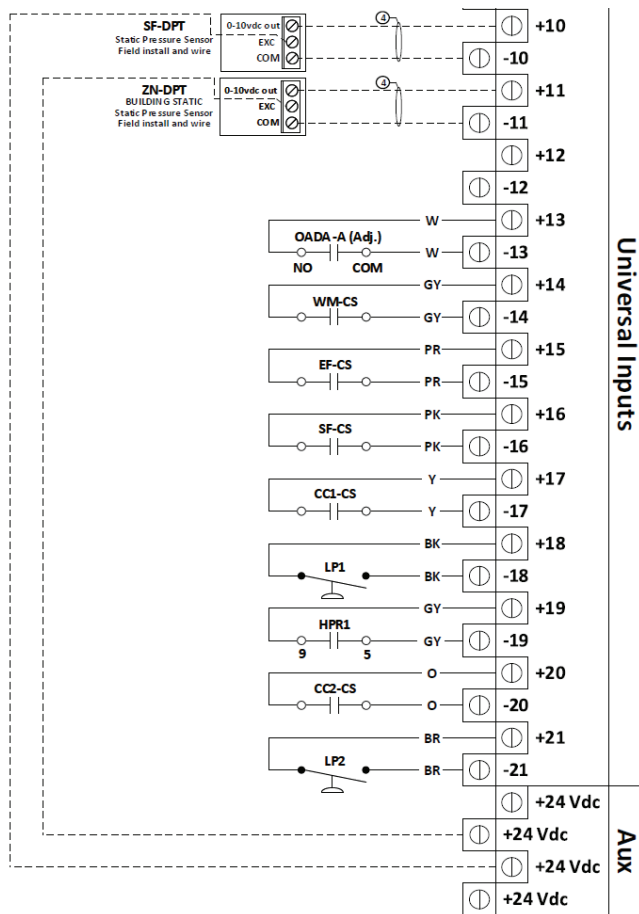

Fig. 75 — DPT Wiring

Clogged Filter Indicator

The clogged filter indicator (CFI) is factory mounted and wired, and is located inside the control cabinet. The CFI switch is wired to terminals + and - of UI-25 on the LS-1628u controller. The CFI is only included on the final filter section, and not on the ERV filter section. See Table 17 for CFI specifications.

Table 17 — Clogged Filter Indicator

SENSOR NAME	Honeywell S830A1062
POWER	1.5A at 24 VAC (7.5 LRA)
PRESSURE SETTING	Adjustable
RESET	Manual
OPERATING TEMPERATURE RANGE	-40 to 149°F (-40 to 65°C)
OPERATING RH	0 to 95%, non-condensing
OVERALL DIMENSIONS	Width: 2.25 in. Height: 3.25 in. Depth: 2 in.

SET UP

- Turn the adjusting screw on the front clockwise until tight (do not strip threads).
- Turn the fan on at high speed.
- Reset the flag, if showing.
- Turn the screw counter-clockwise, until the flag shows.
- Turn the screw clockwise 1-1/2 turns and reset the flag.

RESET

Turn the red knob on the front of the switch, until the flag disappears.

Phase Monitor

A phase monitor is included on all 62W units with Revision K controls. The phase monitor is used to monitor the input power for phasing, balance, over/under voltage, and power loss to protect the unit components from damage. If any of the above conditions are detected by the phase monitor, unit control power will be interrupted and the unit will be unable to operate. When the power state returns to normal, the power monitor will allow control operation. The power monitor features adjustable delay on make, delay on break, and voltage unbalance dials on the top of the monitor. See Table 18 and Fig. 77 for power monitor specifications.

Table 18 — Phase Monitor

SENSOR NAME	R-K Electronics DPM
LINE VOLTAGES MONITORED	200 to 240VAC, 1Ø, 50/60Hz 200 to 600VAC, 3Ø, 50/60Hz
FREQUENCY RANGE	45 to 65 Hertz for all voltages
PHASE ROTATION	A-B-C
FAULTS	Overvoltage
	Undervoltage
	Phase Loss
	Phase Rotation
	Phase Imbalance
	Frequency Out of Range
OVER/UNDERVOLTAGE%	7 to 15%
TRIP TIME DELAY	2 to 10 seconds
RE-START TIME DELAY	Manual reset to 4 minutes
PHASE IMBALANCE %	3 to 10%
PHASE LOSS	≥30% low voltage in any one phase
DIMENSIONS	Width: 3 in.
	Height: 5 in.
	Depth: 2in.

Energy Management Relay

The 62W units have Emergency Relay (EMR) functionality built in to the unit controller. The EMR can act as an emergency shut-down. Use of the emergency relay requires a field provided and installed relay. For Emergency Shutdown applications, a normally closed (N.C.) relay is recommended. The typical wiring connection for the relay is from UI-27 on the LS-1628u controller. See the Tech Settings screen for Emergency Shutdown (EMR) settings. Consult the unit wiring diagram for specific wiring locations. See Fig. 76.

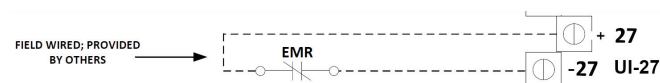

Fig. 76 — EMR Wiring

VFD Control

SUPPLY/EXHAUST

The DC1 VFD may be used to control the speed of various motors. See Fig. 77 and 78. The VFD can be controlled in three ways:

- No duct pressure transducer (DPT) or airflow monitoring station selected** — The VFD, which is standard on the 62W unit, or ECM will be used to balance the airflow and the unit will be treated as a constant volume unit.
- DPT option** — The ECM or the VFD will be controlled by a duct pressure sensor (refer to Fig. 75) to maintain a specific set duct pressure. The supply fan is controlled to the duct pressure and the exhaust fan (if the unit has exhaust) is controlled to the space pressure.
- Airflow monitoring station option** — The unit will adjust the fans to maintain a specific CFM required.

P-10 must be set first on supply and exhaust fans as this changes P-01 and P-02 from Hz to RPM.

P-14 must be set to access the higher parameters.

See Tables 19-21.

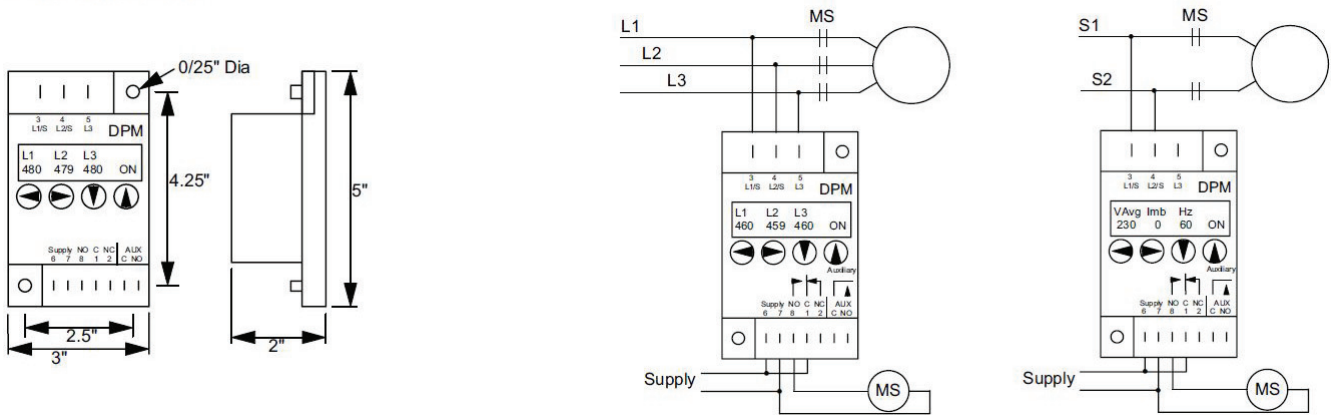

Fig. 77 — Phase Monitor Details

Commands	Description
	Press the OK button and hold it down for two seconds in order to access the parameter interface → The display will show the parameter that was last used.
	Use the ▲ and ▼ buttons to select a parameter
	Press the OK button.
	Use the ▲ and ▼ buttons to change the parameter's value
	Press the OK button to confirm the parameter value change.
	Press the OK button and hold it down for two seconds in order to exit the parameter interface
Navigating between parameter groups	
	The parameters are in sequential order. This means that moving forward from the last parameter in a parameter group will take you to the first parameter in the next parameter group and the other way around.



Fig. 78 — DC1 VFD Control

Table 19 – Supply Fan Parameters 0-10V Control

ID	VALUE	DESCRIPTION
P-01	Set to 1800 for belt driven blowers. Set per work order for direct drive.	f-max
P-02	Set to half of P-01	f-min
P-03	20 s	t-acc
P-04	20 s	t-dec
P-05	0: Ramp to stop	Stop Mode
P-08	Set per serial tag	Motor Nom Current
P-09	60 Hz	Motor Nom Frequency
P-10	1800/3600 Set per motor	Motor Nom Speed
P-14	101	Password
P-15	4	D1 Config Select
P-35	200.0%	AI1 Gain
P-39	50.0%	AI1 Offset

Table 20 – Exhaust Fan Parameters 0-10V Control

ID	VALUE	DESCRIPTION
P-01	Set to 1800 for belt driven blowers. Set per work order for direct drive.	f-max
P-03	20 s	t-acc
P-04	20 s	t-dec
P-05	0: Ramp to stop	Stop Mode
P-08	Set per serial tag	Motor Nom Current
P-09	60 Hz	Motor Nom Frequency
P-10	1800 set per motor	Motor Nom Speed
P-14	101	Password
P-15	4	Di Config Select

Table 21 – Energy Conservation Wheel Parameters 0-10V Control

ID	VALUE	DESCRIPTION
P-03	20 s	t-acc
P-04	20 s	t-dec
P-08	Set per serial tag	Motor Nom Current
P-09	60 Hz	Motor Nom Frequency
P-14	101	Password
P-15	4	Di Config Select

The basic instructions for setting up a Comefri®¹ Electronic Cometer to display the correct CFM and output are as follows:

0-10VDC to OEM controller (See Fig. 79 and 80.)

1. Set Dip Switch #3 in on Position enables flow monitoring.
2. Look up the type and size of the specific blower in Fig. 80.
3. Please note that PR series units use ANPA blowers for “Air-foil” blowers and ANPL blowers for backwards inclined “BI” blowers.
4. Press the “OK” switch to access the “Flow Rate”. Using the “UP” and “DOWN” buttons set the “Flow Rate” to 1000, 3000, 5000, 9999, or 30.00 based on the CFM of the blower. Press “OK”. This figure must match maximum AMS range on the “AMS SETTINGS” screen of the OEM.
5. Use the “Up” and “Down” buttons to set the first digit of the Blower Types K-factor. Press “OK”.
6. Use the “Up” and “Down” buttons to set the second digit of the Blower Types K-factor. Press “OK”.
7. Use the “Up” and “Down” buttons to set the third digit of the Blower Types K-factor. Press “OK”.
8. Use the “Up” and “Down” buttons to set the fourth digit of the Blower Types K-factor. Press “OK”.
9. Use the “Up” and “Down” buttons to set the place value of the “.”. Press “OK”.
10. The Cometer should now be set.
11. Place label near Cometer that states “K-factor may require adjustment during test and balance.”
12. Field calibration can be achieved by adjusting the K-factor upwards or downwards as needed to match test and balance.

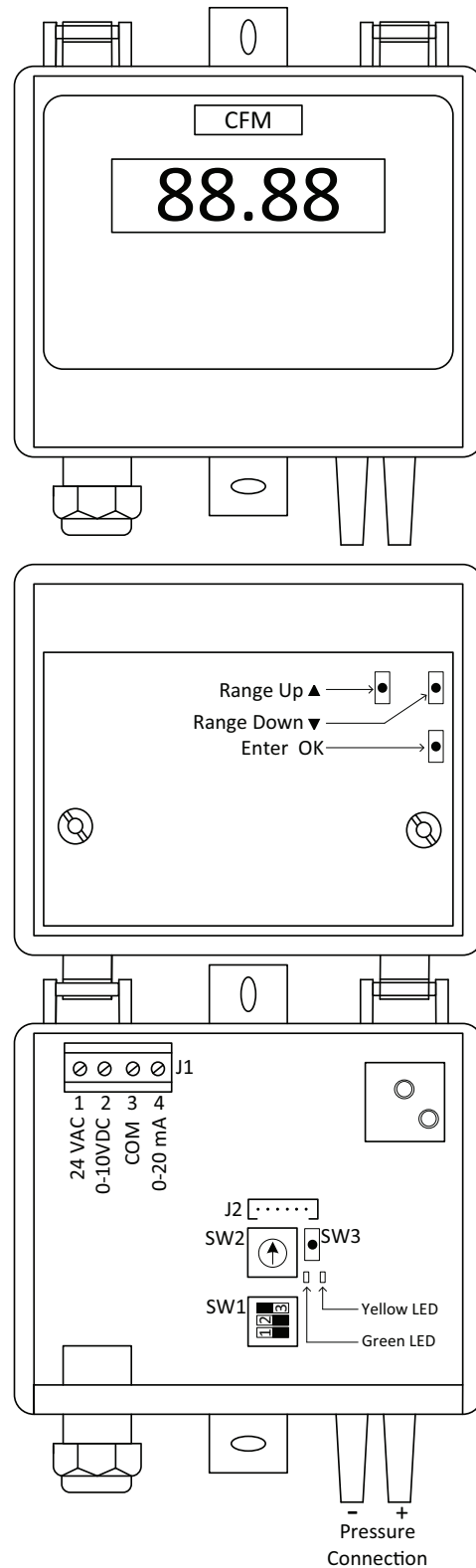

Fig. 79 – Comefri Electronic Cometer

1. Third-party trademarks and logos are the property of their respective owners.

5000

-Factor Example for a THLZ 250 Blower with Comfri supplied
K-Factor of 173.75

173.3

0962I-4912 Rev.D
Cometer Setup
06/26/2017
Page 1 of 3
DWGLWF CHK JW

ANPA BLOWERS ARE USED AS BACKWARDS INCLINED "BI" BLOWERS ON PR UNITS

ANPA Blowers	K-Factor
ANPA 12	76.74
ANPA14	101.82
ANPA 16	131.45
ANPA 18	145.89
ANPA 20	196.80
ANPA 22	249.99
ANPA 25	313.82
ANPA 28	423.99
ANPA 32	518.98
ANPA 36	667.15
ANPA 40	864.71
ANPA 44	974.88
ANPA 49	1271.22
ANPA 55	1594.92

ANPL Blowers	K-Factor
ANPL 10	37.30
ANPL 11	45.48
ANPL 12	56.28
ANPL 14	75.91
ANPL 16	105.36
ANPL 18	135.13
ANPL 20	165.56
ANPL 22	203.52
ANPL 25	264.70
ANPL 28	345.20
ANPL 32	429.61
ANPL 36	531.05
ANPL 40	651.78
ANPL 44	814.89
ANPL 49	941.62
ANPL 55	1180.64

Fig. 80 — Blower K-Factors

Hot Water Heating Control

The control valve for units equipped with hot water coils is to be field provided and installed. The control valve will also require field provided power (not from unit). The control signal for the control valve will be provided by the OEM controller by wiring the valve input signal to UO-6 (0 to 10V signal). Valve selection is to be determined by power requirements, pipe size, and water flow and temperature.

Inverter Driven Compressor

62W units, 3 through 55 tons, will have a standard lead circuit inverter driven compressor. The lag circuit will have a standard scroll with hot gas bypass. Inverter driven compressors shall be capable of modulating from 58-100% of nominal compressor capacity. All circuits with inverter compressors shall be equipped with a minimum load control valve.

Condenser Water Regulating Valves and Head Pressure Control

The 62W unit is equipped with head pressure (discharge pressure) control. All 62W units are equipped with one factory installed water regulator valve per refrigerant circuit for head pressure control.

Water regulating vales operate independently from the controller. In cooling mode, water regulating valves will modulate (never more than 80% closed) for operating at low entering condenser water temperatures.

In heating mode, valves will remain open 100% of the time. See Fig. 81-82 for wiring.

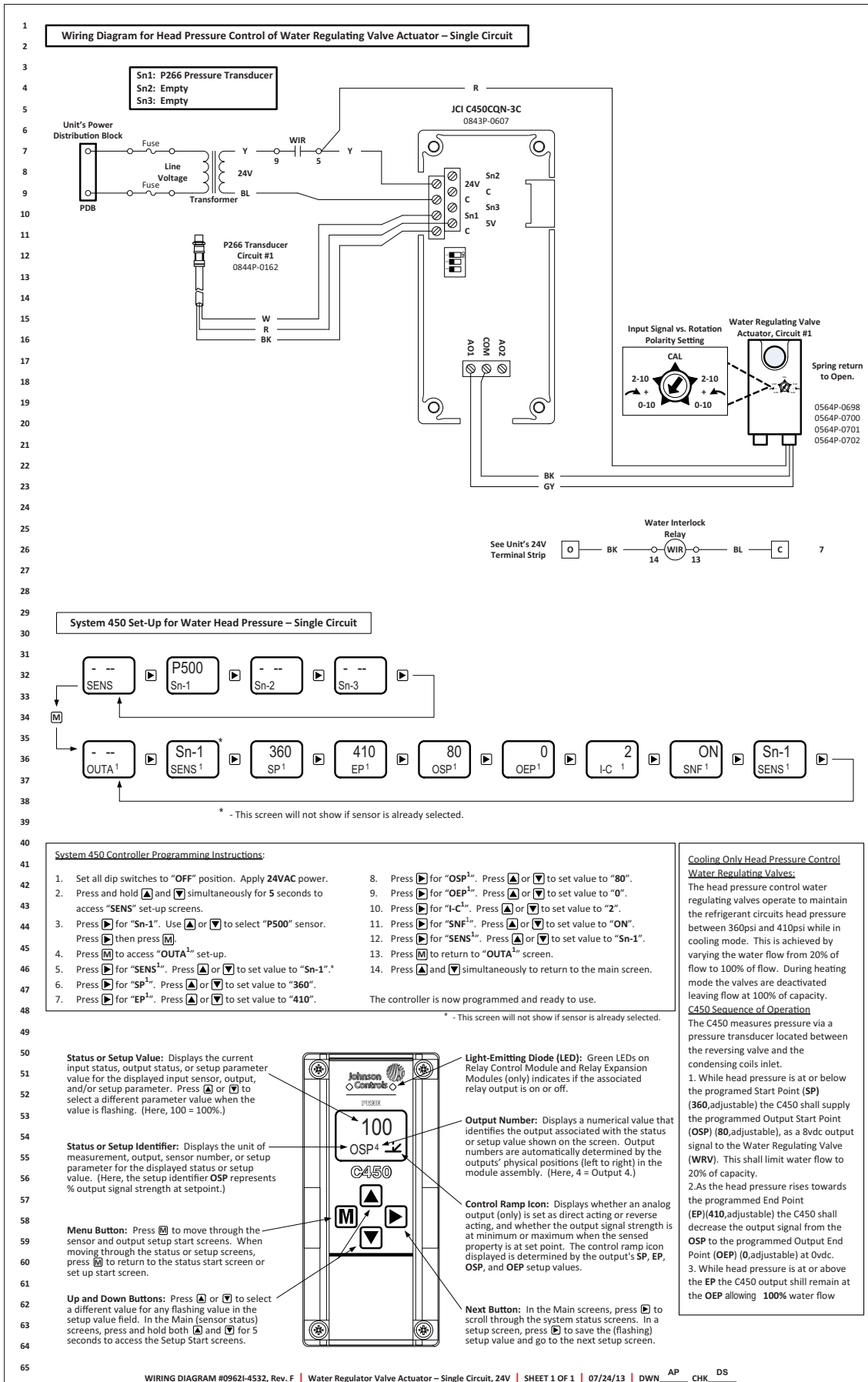

Fig. 81 – Wiring Diagram for Head Pressure Control of Water Regulating Valve - Single Circuit

HEATING

The 62W units may be equipped with gas or electric heat. The gas heat may be staged or modulating control. The electric heat may be staged or SCR (Silicon Controlled Rectifier) control.

Set Points

The control set points are the same for gas or electric heat.

Heating mode will be initiated based upon the outdoor air temperature (OAT) heating set point (default is 55°F).

If the unit has modulating gas heat or SCR controlled electric heat, the control will modulate to maintain a SAT (default is 70°F).

If the supply fan is set to enable only for cooling or heating, it will continue to operate for two minutes after a heating mode.

Ignition Control

Units equipped with gas heat have an electronic ignition control. The control is equipped with an LED for diagnostics and service. See controller diagram Fig. 83.

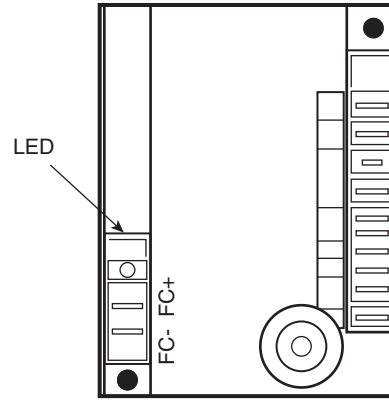

SERIES 35-61 IGNITION CONTROL MODULE

Fault Conditions and LED Key

LED Steady On	System Control Fault
1 Flash	Combustion Air Flow Fault
2 Flash	Flame with No Call for Heat
3 Flash	Ignition Lockout

NOTE: LED flashes on for 1/4 second, and off for 1/4 second during default condition. Pause between fault codes is 3 seconds.

Fig. 83 — Controller Diagram

Flame Current Sensor

The flame current sensor may be tested by the following procedure:

SERVICE CHECKS

Flame current is the current which passes through the flame from the sensor to ground. The minimum flame current necessary to keep the system from lockout is 0.7 microamps. To measure flame current, connect analog DC microamp meter to the FC- and FC+ terminals per Fig. 84. Meter should read 0.7 μ A or higher. If the meter reads below "0" on scale, meter leads are reversed. Disconnect power and reconnect meter leads for proper polarity. See Fig. 84.

See Table 22 for a detailed explanation of the LED codes.

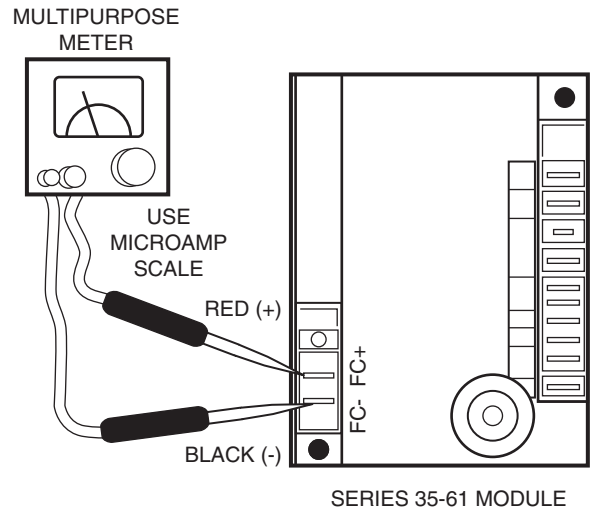

Fig. 84 – Flame Current Detection

Table 22 – LED Codes

LED CODE	SYSTEM	DESCRIPTION	ACTIONS
None	No Power to T1	On call for heat nothing happens.	<ol style="list-style-type: none"> 1. Check for open fuse or circuit breaker. 2. Check for poor wiring connection. 3. Check for failed 24V transformer.
Steady On	No Operation	24 VAC across terminal 24 VAC/V2-Gnd when thermostat calling for heat.	<ol style="list-style-type: none"> 1. System fault. Repeated lockouts (5) during continuous call for heat. 2. Check input voltage and inlet gas pressure during system operation. 3. Check for condensate or blockage in air tube or pressure switch. 4. Check for blocked vent condition or obstruction in heat exchanger tube. 5. If sequencer is used check delay time setting. 6. Control fault. Replace control.
None	Open Limit Switch	Thermostat call for heat. No power across terminals V1/V2 on control.	<ol style="list-style-type: none"> 1. Check for proper operation of circulating air supply system and for air filter blockage. 2. Check manifold pressure when limit cools and closes. Natural gas 3.5 in. wg / LP gas 10.0 in. wg Low combustion blower air output. Flue gas temp exceeds 550°F. Inspect for debris accumulation, proper wheel attachment, proper voltage to blower.
1 Flash	Air Flow Fault	Pressure switch contacts in closed position for 30 seconds with no output to combustion blower. Remains in this mode with combustion blower off. Open pressure switch or flame rollout switch when inducer (IND terminal) is energized. If switch remains open for more than 30 seconds after combustion blower is energized, control will remain in this mode with IND terminal (blower) energized.	<ol style="list-style-type: none"> 1. Check for short in wiring to pressure switch. 2. Check pressure switch for closed contacts (with leads disconnected). 3. Replace pressure switch. 1. Failed combustion blower. 2. Check connections and air tube from draft inducer to air switch for leaks. 3. Check rollout switch manual reset - depress reset. 4. Check supply tube from draft inducer housing to pressure switches for condensate - drain line and reconnect. 5. Check pressure switch for condensate accumulation. 6. Replace pressure switch.
2 Flash	Flame Fault	Flame sense failure/flame present with no call for heat.	<ol style="list-style-type: none"> 1. Check for voltage to gas valve with thermostat in off position. Valve should not be powered. 2. If valve is not energized, check for gas flow (manifold pressure reading greater than 0). If gas flow, turn off main shut-off valve or replace gas valve.
3 Flash	Lockout	Failure to light and or carryover, loss of flame or flame signal during ignition or operating cycle. Control will initiate up to 3 ignition re-trials before lockout.	<ol style="list-style-type: none"> 1. Verify gas supply available and operation of gas valve - manifold pressure at start of ignition cycle. Check for power to valve terminals LO and COM while spark is energized. 2. Is spark present? If not check igniter for debris between electrodes, cracked ceramic and check ignition wire for short to ground. 3. Check flame sensor wiring connections to electrode and control and for any abrasions. 4. Check for cracked ceramic on flame sensor or grounded sensor rod. 5. Verify that ample air supply and proper venting of flue gases occurs during operating cycle. 6. Check for circulating air leaks into burner compartment during operation. 7. Check for re-circulation of flue gases into combustion air supply. 8. If all conditions satisfactory - replace ignition control.

Staged Heat

If the ECAT is below ECAT heating set point, first stage heating will be initiated. If the leaving air temperature (LAT) is below the LAT set point (default is 70°F), the second stage of heating will be initiated.

When system is powered up 24 VAC will be applied to the ignition control (IC) terminals 24VAC / R and to the Timer Relay Control (TR1). The ignition control will reset, perform a self check routine, initiate full time flame sensing, flash the diagnostic LED for up to four seconds and enter the thermostat scan standby state. The amber light on the TR1 will be lit indicating it is in the ready position.

See Fig. 85-88 for staged heat wiring diagram and typical horizontal and vertical installation.

CALL FOR HEAT

1. Controller (first stage or first and second stage) closes on call for heat.
2. 24 VAC to is supplied to IC terminal TH, provided limit switch is in closed position.
3. The control will check that pressure switch contacts are open (IC terminal PSW is not powered).
4. Combustion blower is then energized at high speed.
5. When the Air Switch (APS1) closes, a 15-second pre-purge period begins.
6. At end of pre-purge period, the spark commences and the first and second stage gas valves are energized for the trial for ignition period.
7. Burners ignite and cross light, operating at maximum input rate (manifold pressure 3.5 in. wg).
8. The TR1 is powered (terminal 7) simultaneously (SR LED lit) and begins timing a 90-second warm-up period while maintaining the combustion blower at high speed (FR LED lit). The TR1 will maintain this mode of operation, regardless of status of thermostat second stage.
9. When flame is detected by flame sensor, the spark is shut-off immediately and gas valves and combustion blower remain energized.
10. When the initial timer in TR1 times out, it defaults the gas valve to low fire and the combustion blower to low speed and returns control of the operating mode to the temperature controller. The SR LED turns off and the MR LED is lit.
11. If the controller is calling for second stage heat TR1 terminal 6 is powered. After a short time delay (approximately 15 seconds), the system switches the combustion blower to high speed (FR LED lit) and the second stage gas valve at 3.5 in. wg manifold pressure (CR LED lit), provided the High Air Pressure Switch (APS2) is proved.
12. During heating operation, the thermostat, pressure switch and main burner flame are constantly monitored by the IC to assure proper system operation.
13. Operation continues on High fire until the second stage thermostat is satisfied, opening the second stage contact and de-energizes terminal 6 on the TR1, turning off the second stage gas valve and returning the combustion blower to low speed.
14. When the thermostat (controller) is satisfied and the demand for heat ends, the first stage valve is de-energized immediately, the control senses loss of flame and a 30-second post-purge occurs (at high speed) before de-energizing the combustion blower.

IGNITION AND OPERATIONAL FAILURES DURING A CALL FOR HEAT RESULT IN "LOCKOUT" OF THE IGNITION CONTROL

1. If flame is lost during an operational cycle, the control will respond within 0.8 seconds. The spark will be energized for a trial for ignition period to attempt to relight burners and prove flame sensor. If flame is re-established, normal operation resumes.
2. If the burners fail to light or carryover during a trial for ignition, the control will attempt two additional ignition trials. If no flame is present at the flame sensor within 10 seconds, the spark and gas valve will be de-energized. A 15-second inter-purge period begins and the combustion blower continues to run. After the inter-purge period another ignition trial will take place.
3. If burner fails to light or prove the flame sensor following the two additional trials the control will go into lockout. The valve relay in the IC will be de-energized, shutting of the gas valve immediately and the combustion blower following a 30-second post-purge period.

RECOVERY FROM LOCKOUT

1. If the thermostat (controller) is still calling for heat one hour after a lockout occurs, the control will automatically reset and initiate a call for heat sequence.
2. The ignition control may also be manually reset, by turning the thermostat (controller) down and back up to previous temperature setting or removing power (24V) to IC terminal 24VAC.

IC FAULT CONDITIONS AND LED KEY

Table 23 lists LED flashing codes and their meanings.

Table 23 — LED Codes

LED	MEANING
LED Steady On	Internal Control Fault
1 Flash	Combustion Air Flow Fault
2 Flash	Flame with No Call for Heat
3 Flash	Ignition Lockout

NOTE: LED flashes on for 1/4 second, and off for 1/4 second during fault condition. Pause between fault codes is 3 seconds.

1. If during the initial call for heat the air switch contacts are closed for 30 seconds without an output to the combustion blower, an airflow fault occurs (one LED flash) and control will remain in this mode.
2. If the airflow switch remains open (or a rollout switch is open) for more than 30 seconds after the combustion blower output (IND) is energized, an airflow fault occurs (one LED flash), and control will stay in this mode with combustion blower on, waiting for airflow switch (or rollout) to close.
3. If the airflow signal is lost during operation, the control immediately de-energizes the gas valve and maintains blower operation. If the call for heat remains and proper airflow is not detected, and airflow fault occurs (one LED flash). If proper airflow is detected at any time, the normal sequence will begin with pre-purge.
4. If the main valve fails to close properly at the end of a heating cycle and a flame is maintained, the combustion blower will continue in operation. If the valve does close completely later removing the flame signal, the blower will run for the post purge period and shut off.

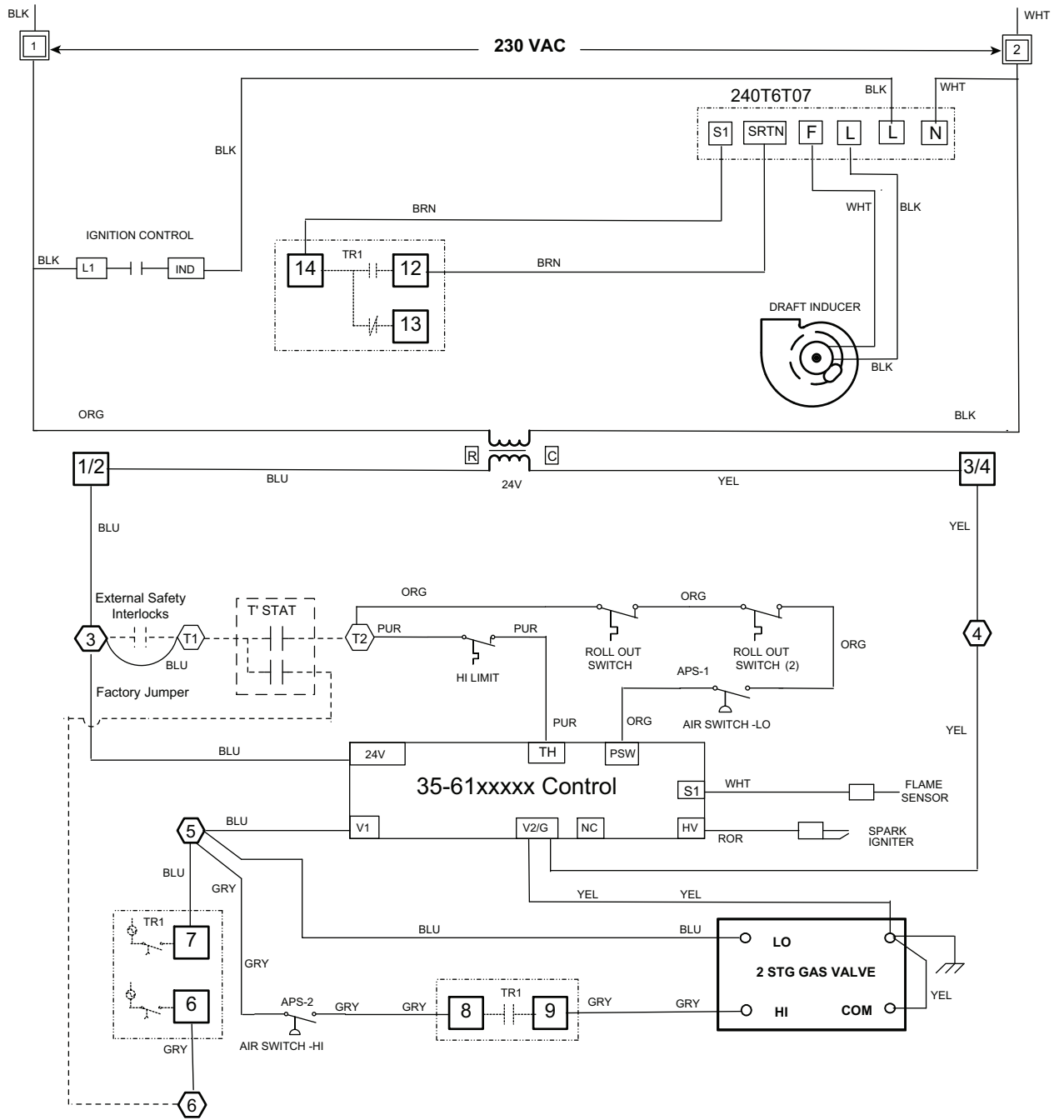

[---] CUSTOMER PROVIDED COMPONENT

----- CUSTOMER / FIELD WIRING

[1] INTERNAL TERMINAL CONNECTION

[3] EXTERNAL TERMINAL CONNECTION

(2) 2nd ROLLOUT SWITCH ON HORIZONTAL BURNER TRAY ONLY

[---] TIMER RELAY - TR1-090HH15

[1/2] TR1 TIMER RELAY TERMINAL CONNECTION

Fig. 85 — Staged Heat Wiring Diagram

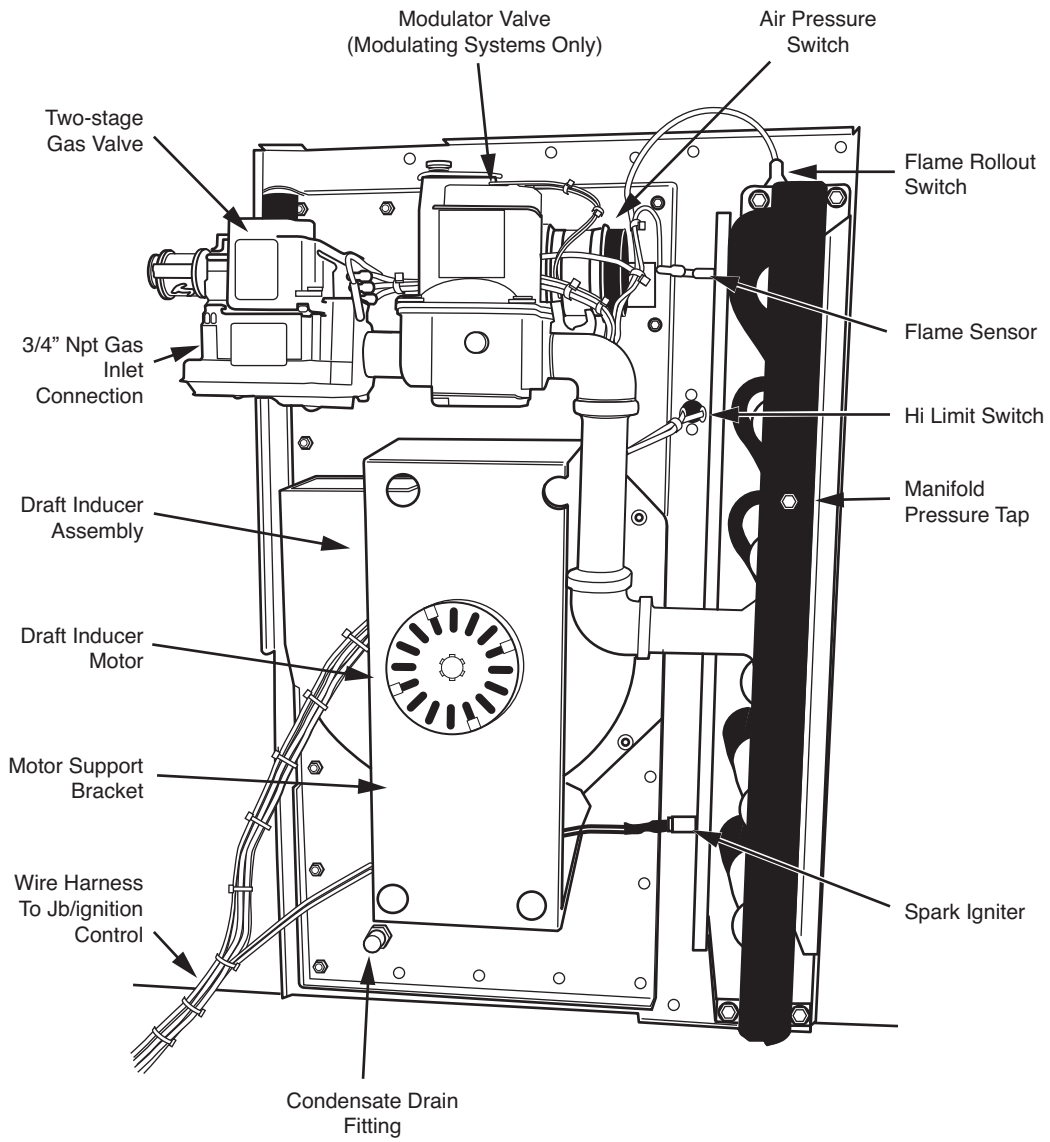

Fig. 86 — Horizontal Unit with Modulating Gas Heat

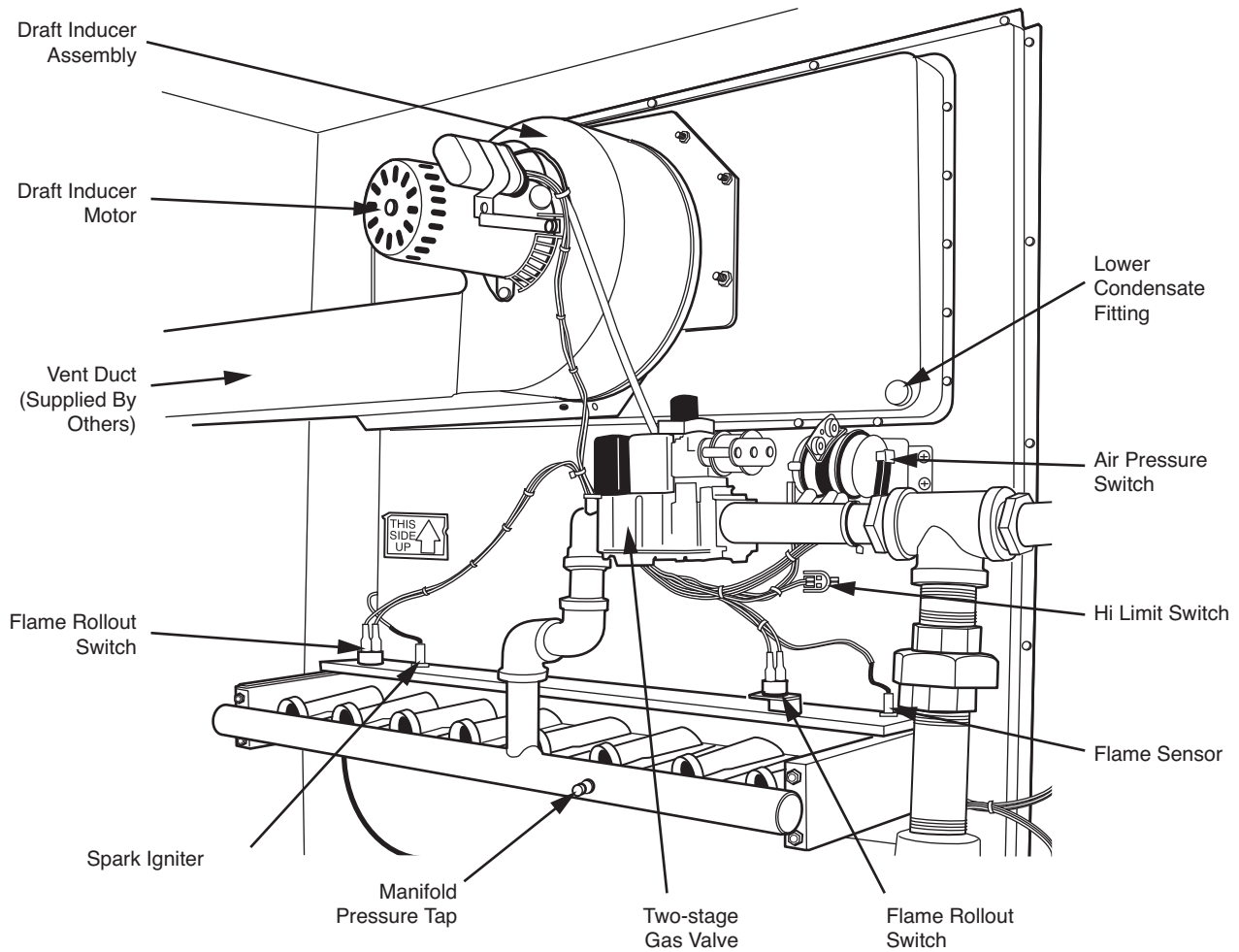

Fig. 87 — Vertical Unit with Staged Gas Heat

Draft Fan Pressure Measurement HM Series Heat Module

1. Remove air pressure supply tube from fan at pressure switch connection. See Fig. 88, A.
2. Insert “T” into supply tube. See Fig. 88, B.
3. Attach additional piece of tubing from “T” to pressure switch. See Fig. 88, C.
4. Connect remaining leg of “T” to pressure measuring device (measure in. wg). See Fig. 88, D.
NOTE: Connect to “low” side of digital monometer as combustion blower pressure is negative at test point.
5. Place system in operation and observe pressure reading. Check chart below to ensure that pressure is greater than noted for ambient operation.
6. After heater fires, allow unit to operate for 10 to 15 minutes. Observe pressure reading and check Table 24 to verify pressure is greater than noted for “steady state.”

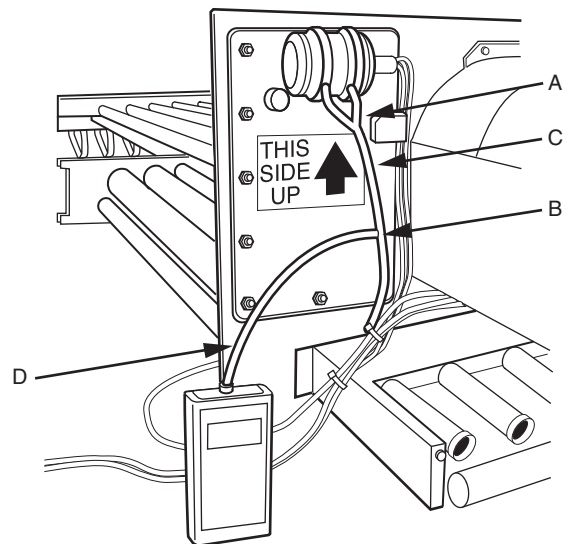

Fig. 88 — Draft Fan Pressure Measurement

Table 24 — Pressure Reading

SERIES	AMBIENT (Min. in. wg)	HIGH FIRE STEADY STATE (Min. in. wg)
HMA	-3.50	-1.70
HMB	-3.50	-1.90
HMG	-2.80	-1.70

NOTE: Readings below those noted indicate a potential problem with the installation and may be the result of low voltage to combustion blower motor, a loose or damaged blower wheel, restriction in the vent piping, inadequate vent system, or negative pressure in the building (indoor applications only).

Manifold Pressures

The gas valve manifold pressures may be measured at the gas valve test ports, see Fig. 89. See Tables 25 and 26 for typical gas heat data points and modulating gas heat data points.

Modulating Gas Heat

If the OAT is below OAT heating set point, heating will be initiated. The modulating heat valve(s) will control to a LAT of 72°F. Units with modulating gas heat may also have ‘Override’ control. Override control (sometimes called high fire override) is used to quickly raise the space temperature. For example, if the space is cold early in the morning, the unit will sense the low space temperature and go into high fire override even if the outdoor temperature is not that cold. After the space temperature is in the normal range, the unit will then go back to the modulating output mode.

Units equipped with the optional modulating gas heat control will have several components in addition to the standard gas valve. These components includes the following:

MODULATING GAS VALVE

For an example of a modulating gas valve, see Fig. 90.

SIGNAL CONDITIONER (SC30)

See Fig. 91. The signal conditioner has three functions:

1. Convert the 62W controller’s DC output signal of 0 to 10 VDC to a 0 to 20 VDC signal to provide compatibility with the modulating gas valve.
2. Controls the normally open relay used to switch inducer speed and gas valve stage. Closes or opens the relay based on the 62W controller’s DC output to the SC30. Relay closes at approximately 5.3 VDC input. Relay opens at approximately 4.7 VDC input.

3. Provides an adjustable timer (0 to 30 secs) and adjustable VDC (5 to 15 VDC) output to the modulating gas valve at start up (powering of the SC30). Adjustment potentiometers:
 - R18 - 0 to 30 sec timer
 - R22 - 5 to 15 VDC output voltage

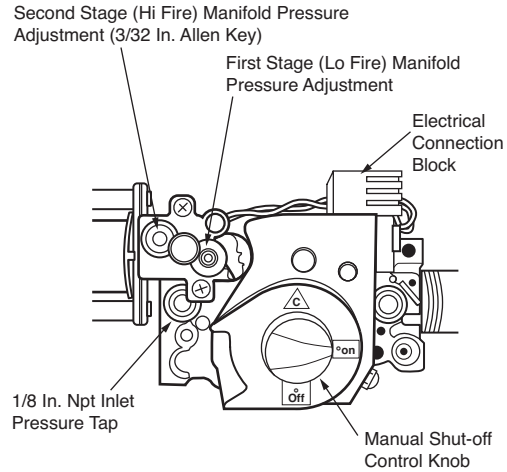

Fig. 89 — Gas Valve Manifold Pressure Ports

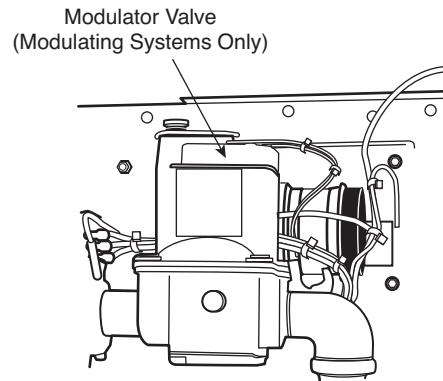

Fig. 90 — Modulating Gas Valve

Table 25 — Typical Gas Heat Data Points

Type of Gas: Natural Gas Pressure at Inlet (burner off): 13.5 in. wg max. Supply voltage at JB: Marked VAC ± 5%

HEATER OPERATING DATA	LOW FIRE	HIGH FIRE
Gas Pressure at Train Inlet	13.3 in. wg	13.0 in. wg (See rating plate for minimum)
Gas Pressure at Burner Manifold	1.1 to 1.3 in. wg	3.3 to 3.5 in. wg
Gas Input Rate	25 to 35% Maximum Input	Rated input less 5% Max.
CO ₂ in Flue Gas	1.8 to 3.2%	6.2 to 7.2%
CO in Flue Gas	<300 ppm	<50 ppm
Flue Gas Temperature at Discharge	>200°F	420 to 520°F Ambient Temperature: -40 to 70°F
Draft Fan at Discharge	-0.80 to -2.00 in. wg	-1.75 to -2.40 in. wg

Table 26 — Additional Data Points for Modulating Gas Heat

MODULATING SYSTEM OPERATION (if applicable)	ANALOG SIGNAL TO SC30	VDC TO MOD VALVE	MANIFOLD PRESSURE
Modulating Gas Heat Option Only	Initial Call for Heat 0 VDC 5 VDC 10 VDC	12.5 to 13.0 VDC 0.5 to 1.0 VDC 9.5 to 10.0 VDC 18.0 to 19.0 VDC	1.1 to 1.4 in. wg 0.4 to 0.6 in. wg 0.9 to 1.2 in. wg 3.2 to 3.5 in. wg

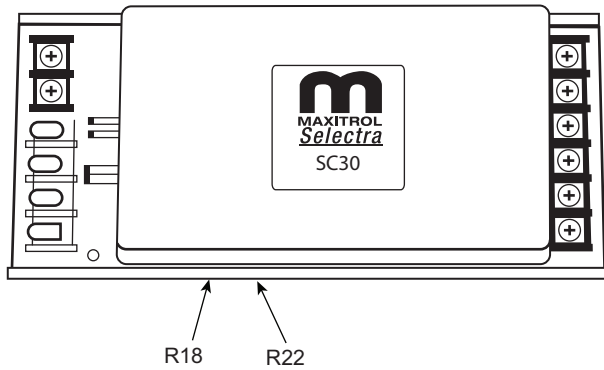

Fig. 91 — Signal Conditioner SC30

IMPORTANT: To avoid internal damage to the SC30 Signal Conditioner the transformer's secondary must not be grounded in any portion of the circuit external to the SC30 Signal Conditioner. If existing transformer is grounded, a separate isolated transformer must be used.

INDUCER FAN SPEED CONTROL

For an example of an inducer fan speed control, see Fig. 92.

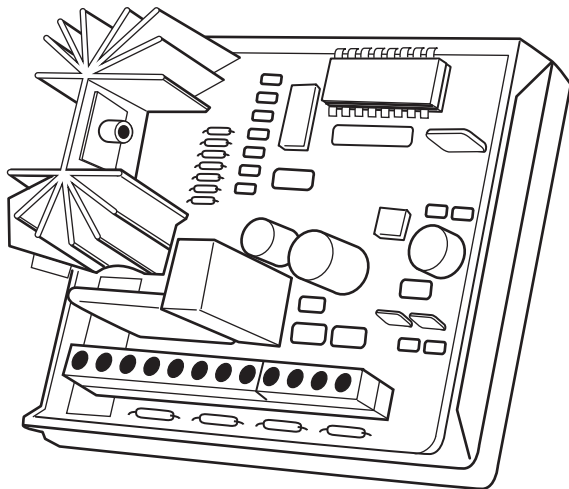

Fig. 92 — Inducer Fan Speed Control

TIMER RELAY CONTROL (TR1)

See Fig. 93. The timer function is as follows:

1. The TR1 receives a 24 vac signal (terminal 7), normally from the ignition control MV gas valve output or the thermostat circuit (see Note 1). Upon receiving the signal the TR1 begins multiple tasks. It starts Timer No. 1, lights the SR LED, places the 2-stage gas valve in either the high or low pressure stage (terminal 9), places the inducer in either the high or low speed (terminal 12, 13) and powers the Series 3 or SC30 (terminal 10).

The TR1 maintains this mode throughout Timer No. 1's duration, regardless of the temperature controller input (it is ignoring terminal 6). The initial gas valve stage, initial inducer stage, and length of time are customer specified and programmed into the TR1. Specifying these factors can eliminate problems associated with lighting the burner at an undesirable input and condensation occurring at start-up. (When using the Maxitrol modulating system, the SC30 and Series 3 controllers output a constant voltage to the modulating gas valve thereby fixing an approximate input rate during the set time after power up. The time, which is often set equal to the TR1 Timer No.1 duration, and the output voltage are fixed or adjustable. See SC30 and Series 3 literature.)

2. When Timer No. 1 expires, the TR1 defaults the gas valve and inducer to low pressure/speed mode and hands control of the required mode, high or low, to the temperature control system. The MR LED lights and the SR LED goes out. The terminal 6 input signal (0 to 24 VAC) now determines if the gas valve and inducer will remain in the low pressure/speed mode or switch over to the high pressure/speed mode.

When the terminal 6 input signals the TR1 to switch to the high output mode, it starts Timer No. 2. Timer No. 2 is programmed to a customer specified time and is used to buffer the low to high switch point. When Timer No. 2 expires, the system switches from low output mode to high output mode (see Note 2).

3. The FR LED lights when the inducer operates in high speed.
4. The CR LED lights when the gas valve operates in the high pressure stage.
5. Use terminal 8 to accept a "made" inducer high air flow switch (HAFS) signal. If the 24 VAC signal is not received, the TR1 keeps the gas valve in the low pressure stage, regardless of the terminal 6 input signal.

NOTE 1: Timer No. 1 resets each time power is removed from terminal 7. **Tip:** By resetting each time power is removed from terminal 7, the fan purge setting and time do not need to be considered, and the start time duration will be the same, even after failed ignition attempt(s).

NOTE 2: Immediate low mode to high mode changeover after Timer No. 1 expiration, or upon receiving required terminal 6 signal, can be accomplished by specifying Timer No. 2 to zero seconds.

CAUTION

To avoid internal damage to the TR1, Transformer No. 2 (see Fig. 94) secondary must not be grounded in any portion of the circuit external to the A1093/SC30. A separate, independent transformer is recommended.

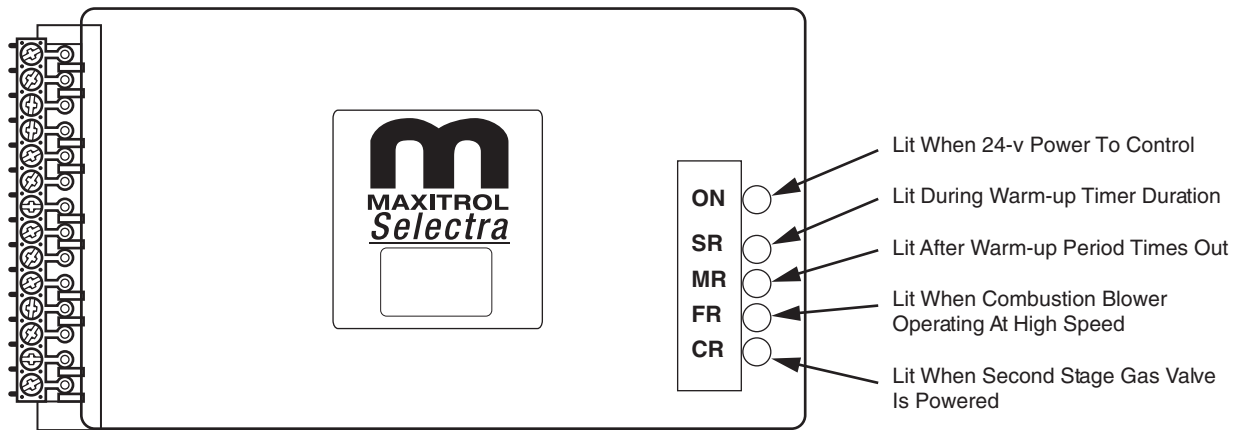

Fig. 93 — Timer Relay Control (TR1)

SEQUENCE OF OPERATION FOR ELECTRONIC MODULATION WITH INDUCER SPEED CONTROL

When the system is powered up 24 VAC will be applied to the ignition control (IC) terminals 24VAC/R and to the Timer Relay Control (TR1). The ignition control will reset, perform a self check routine, initiate full time flame sensing, flash the diagnostics LED for up to four seconds and enter the thermostat scan standby state. The amber light on the TR1 will be lit indicating it is in the ready position. See Fig. 94.

CALL FOR HEAT

1. Thermostat (heat enable) closes on call for heat.
2. 24 VAC is supplied to IC terminal TH, provided limit switch is in closed position.
3. The control will check that pressure switch contacts are open (IC terminal PSW is not powered).
4. Combustion blower is then energized at high speed.
5. When the Air Switch (APS1) closes, a 15-second pre-purge period begins.
6. At end of pre-purge period, the spark commences and the first stage gas valve is energized for the trial for ignition period.
7. TR1 is powered (terminal 7) simultaneously (SR LED lit) and begins timing a 90-second warm-up period while maintaining the combustion blower at high speed (FR LED lit) and powers the SC30. The SC30 will output 12 to 13 VDC to the modulating control valve during the timing duration (90 seconds) of TR1, regardless of the analog input signal to SC30 terminals 7 and 8.
8. Burners ignite and cross light, operating at the adjusted mid-fire input rate (manifold pressure set at 1.2 to 1.5 in. wg).
9. When flame is detected by flame sensor, the spark is shutoff immediately and gas valve(s) and combustion blower remain energized.
10. When the initial timer in TR1 times out, it defaults the gas valve to low fire and the combustion blower to low speed and returns control of the operating mode to the building temperature controller. The SR LED turns off and the MR LED is lit.
11. If the controller is providing an analog signal between 0.5 and 5.3 VDC to the SC30 control, the system will continue to run at low speed combustion blower and with only the first stage valve open. The modulating valve will be powered proportional to the input voltage signal from the controller, and will open or close changing the gas manifold pressure. Manifold pressure will vary from 0.3 to 1.2 in. wg operating in this mode.

12. If the signal increases above 5.3 VDC, the SC30 relay closes powering terminal 6 on the TR1, and starts a second time delay of 15 seconds. At the end of this time delay the fan switches to high speed (FR LED lit) and the second stage gas valve opens (CR LED lit) through the TR1 (terminal 9) provided the High Air Switch contacts are closed. The manifold pressure will vary from 1.4 to 3.5 in. wg in this mode.
13. During heating operation, the thermostat, pressure switch and main burner flame are constantly monitored by the IC to assure proper system operation.
14. Operation continues in the high fire mode until the controller input signal to the SC30 control drops to 4.7 VDC. At this point the SC30 relay circuit opens (SC30 terminal 5 has no output) de-energizing the second stage valve and the TR1 switches the combustion blower to low speed operation. Low-fire modulation will continue as in Step 11.
15. When the thermostat (temperature controller) is satisfied and the demand for heat ends, the heat enable contact opens and the first stage valve is de-energized immediately, the control senses loss of flame and a 30-second post-purge occurs (at high speed) before de-energizing the combustion blower.

IGNITION AND OPERATIONAL FAILURES DURING A CALL FOR HEAT RESULT IN "LOCKOUT" OF THE IGNITION CONTROL

1. If flame is lost during an operational cycle, the control will respond within 0.8 seconds. The spark will be energized for a trial for ignition period to attempt to relight burners and prove flame sensor. If flame is re-established, normal operation resumes.
2. If the burners fail to light or carryover during a trial for ignition, the control will attempt two additional ignition trials. If no flame is present at the flame sensor within 10 seconds, the spark and gas valve will be de-energized. A 15-second inter-purge period begins and the combustion blower continues to run. After the inter-purge period another ignition trial will take place.
3. If burner fails to light or prove the flame sensor following the two additional trials the control will go into lockout. The valve relay in the IC will be de-energized shutting of the gas valve immediately and the combustion blower following a 30-second post-purge period.

RECOVERY FROM LOCKOUT

1. If the thermostat (controller) is still calling for heat one hour after a lockout occurs, the control will automatically reset and initiate a call for heat sequence.

Electric Heat

The 62W units may be equipped with electric heat. The electric heat control may be staged or SCR control. Staged electric heat units with nominal heater capacity of 10 to 25 kW are two stages,

30 kW and larger staged heaters are four stage. SCR control is available on all heater sizes. See Fig. 95-99 for electric heater wiring diagrams.

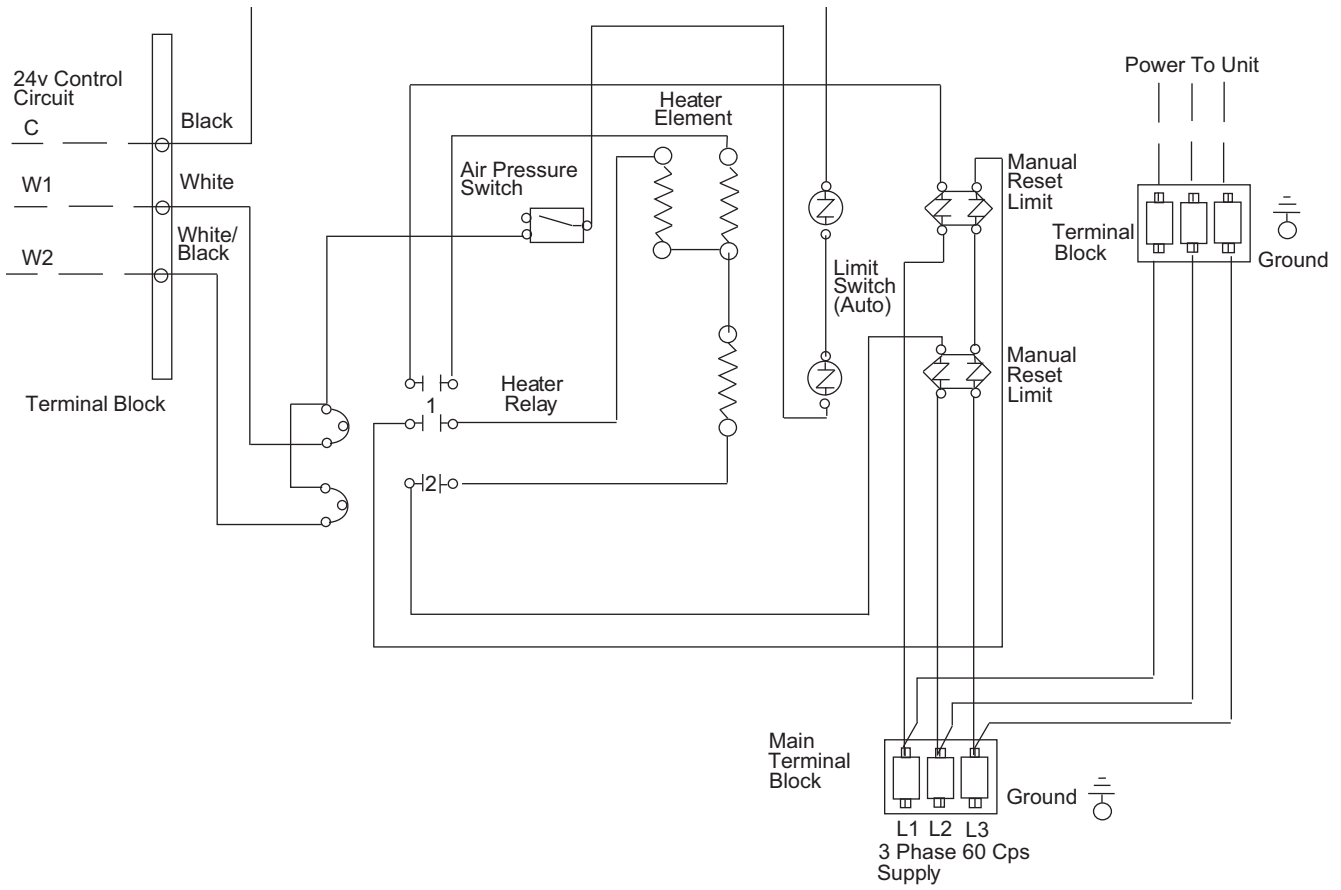

Fig. 95 — Two-Stage, 3-Element Electric Heat

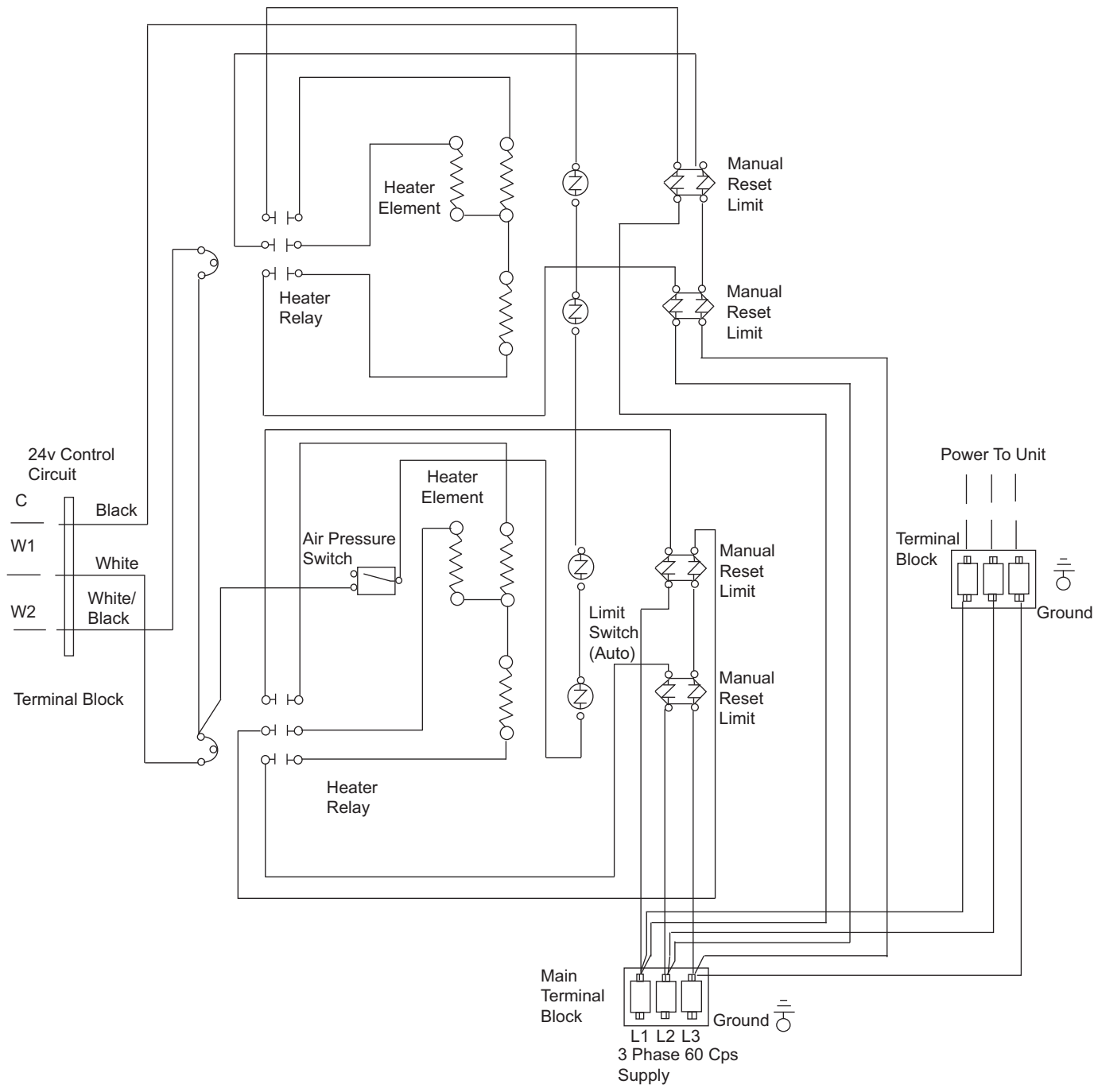

Fig. 96 — Two-Stage, 6-Element Electric Heat

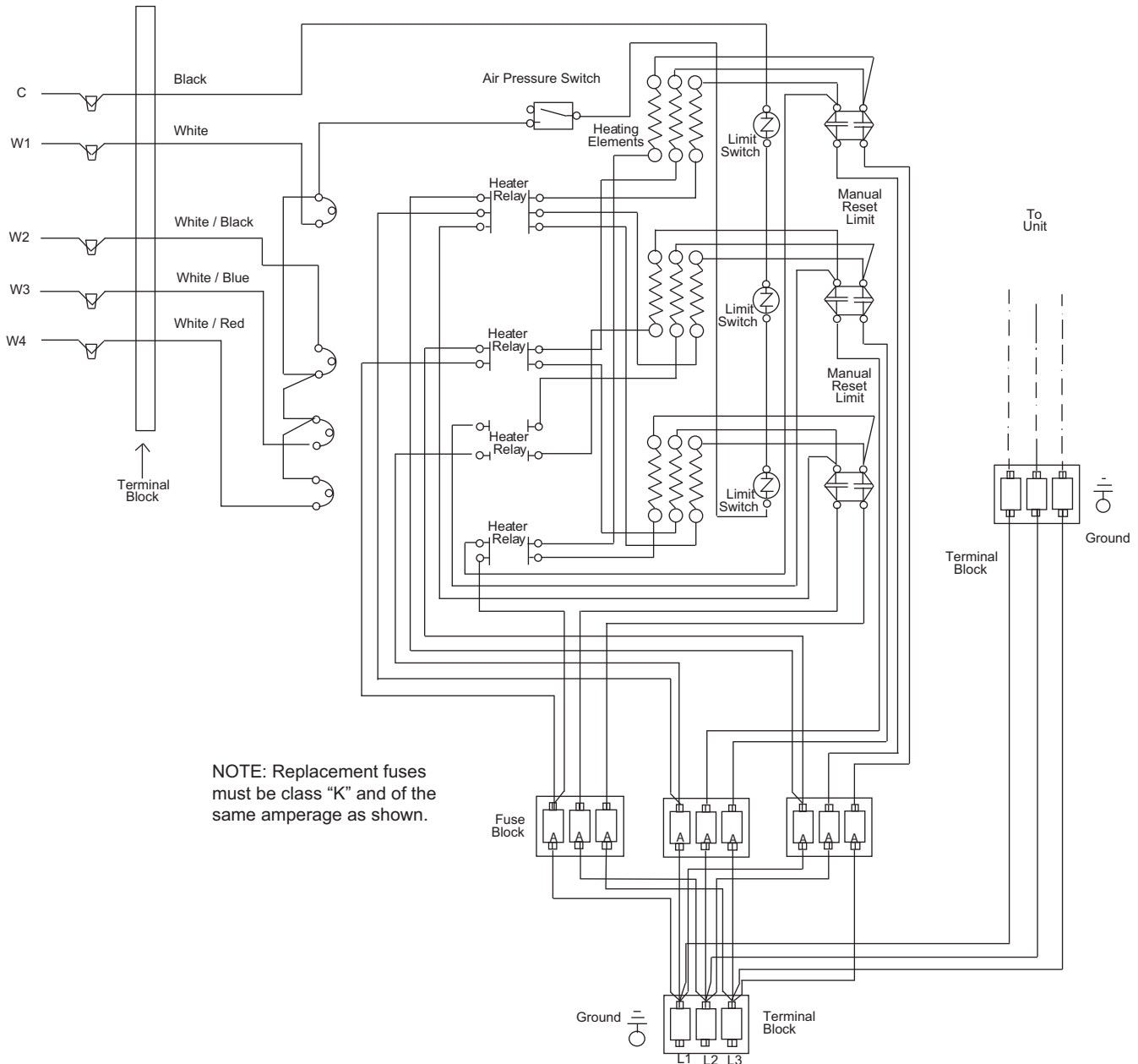

Fig. 97 — Four-Stage, Nine-Element Electric Heat

SCR Controlled Electric Heat

If the OAT is below OAT heating set point, heating will be initiated. The SCRs will control to a LAT of 72°F.

Units equipped the optional SCR controlled electric heat will utilize a SCR power control, see Fig. 98 and 99. This power control will convert a 0 to 10 Vdc input signal from the 62W controller to vary the heater output to maintain the desired leaving-air temperature (LAT). The power control has a DIP switch configuration for the type of input signal. See Table 28 for proper switch settings.

Table 28 — Power Switch Settings

INPUT SIGNAL	SWITCH #1	SWITCH #2	SWITCH #3	SWITCH #4
0 to 10 Vdc Control Signal (2 to 10 Vdc Control Range)	Off	Off	Off	On

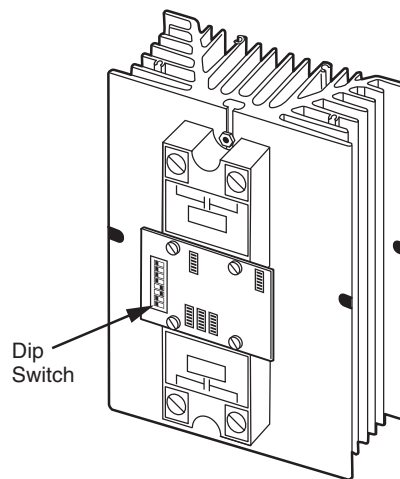

Fig. 98 — SCR Power Control

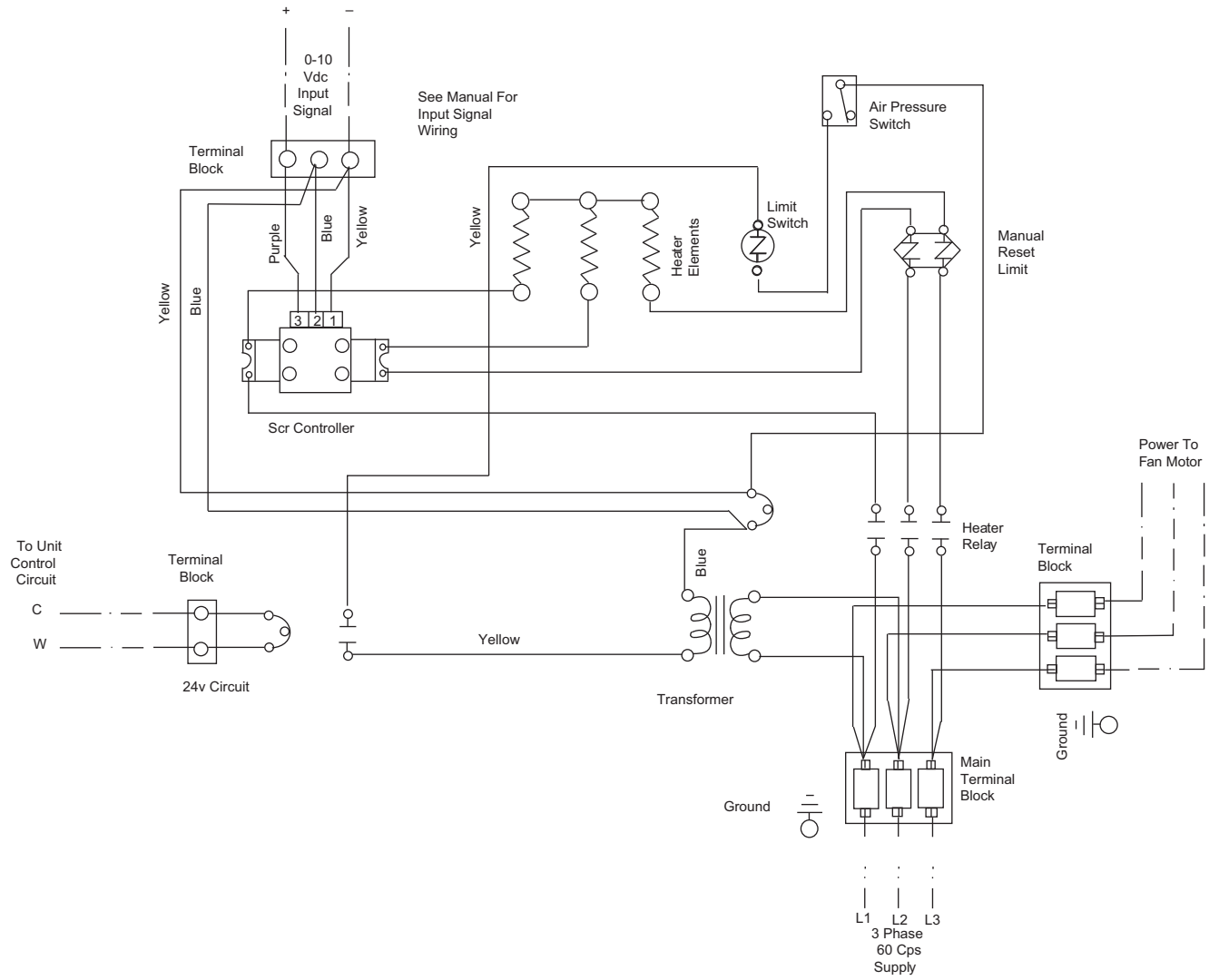

Fig. 99 — SCR Control Electric Heat

ENERGY RECOVERY VENTILATOR CONTROL

The 62W units can be equipped with an optional Synthetic Polymer type Energy Recovery Ventilator (ERV). ERV operation is enabled whenever the unit is in occupied mode. See the Operation section of this manual for ERV operating sequence.

VFD Defrost

The ERV may be equipped with a VFD for frost control. The VFD will slow the rotating speed (45 RPM) to the configured minimum speed (10 RPM) when the temperature of the return air coming off the wheel (WExAT) is equal to or less than 25°F (configurable in the VFD controller). Slowing the wheel will inhibit the formation of frost. Refer to the VFD section for additional information on the VFD.

NOTE: The variable speed defrost control slows down the speed of the wheel to reduce its effectiveness and keeping the return air from getting fully saturated which can lead in condensation of the wheel and possible frosting.

The 25°F default set point does not cover the whole range of applications where frosting may occur. Under certain conditions (high R.H. % from the return air and very low OA DB temperatures) frosting may occur even below the default set point.

This set point **MUST** be adjusted to ensure that the return air when cooled down by the ERV does not reach its dew point temperature.

The Heat source must be sized accordingly to account for reduction in capacity for applications where the unit will enter in defrost mode.

ERV Maintenance

Refer to the most current version of the Dedicated Outdoor Air Installation Instructions for ERV information and maintenance.

ELECTRICAL DATA

Wiring Diagrams

See Fig. 100 for typical wiring information.

62W Electrical Data

Refer to the most current version of the dedicated outdoor air builder for unit electrical data.

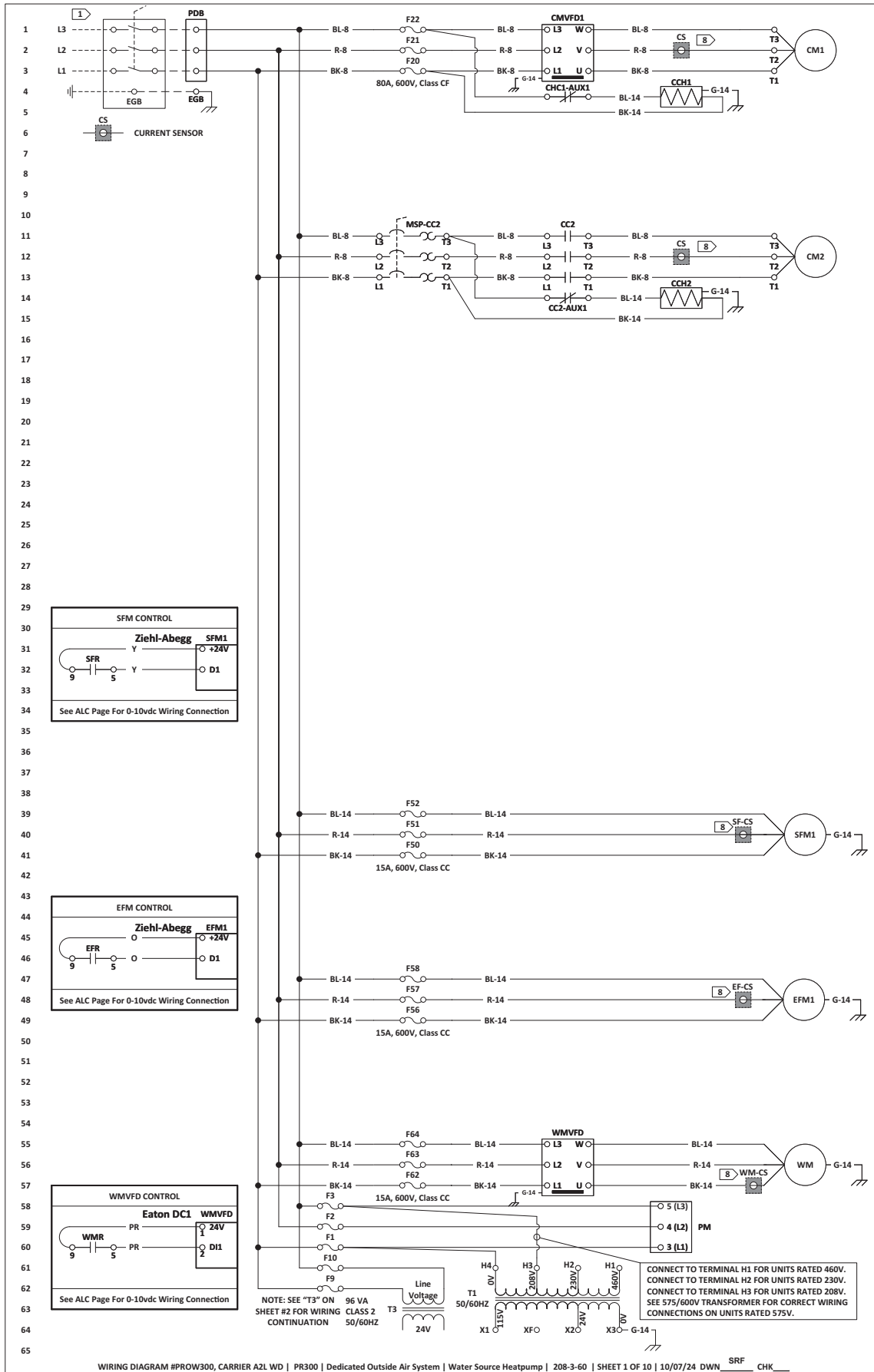

Fig. 100 – Typical Wiring Diagram

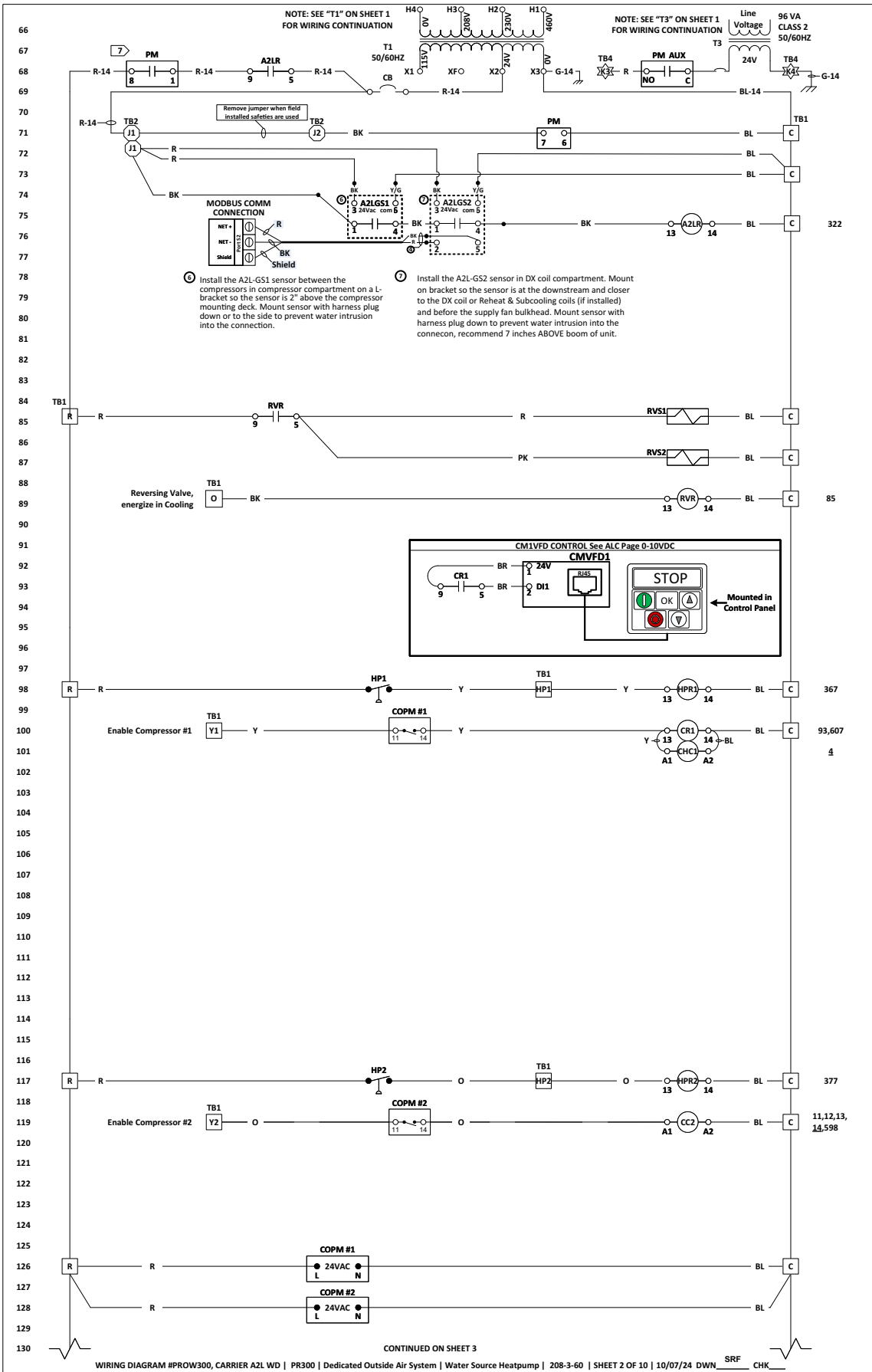

Fig. 100 – Typical Wiring Diagram (cont)

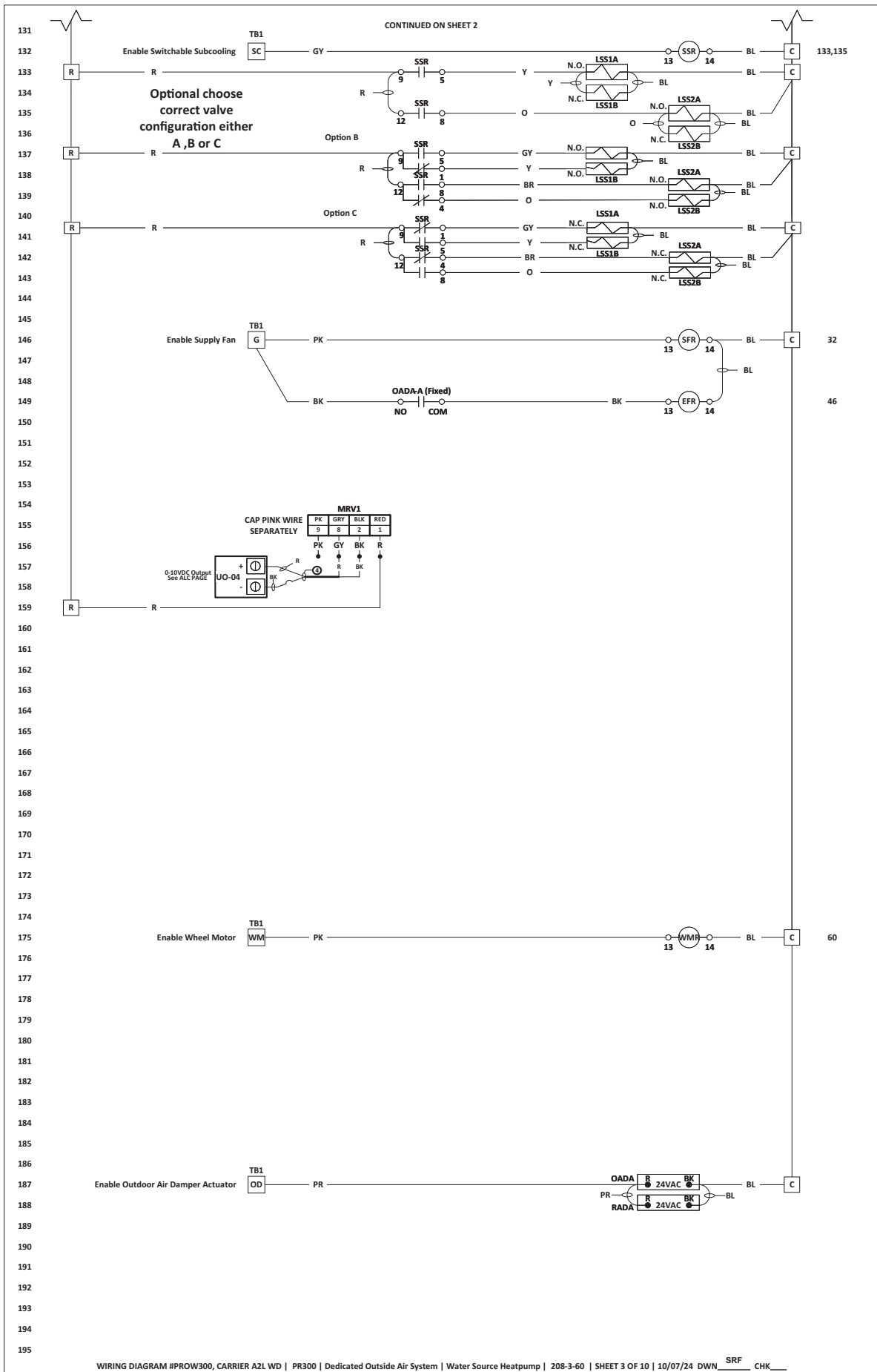

Fig. 100 – Typical Wiring Diagram (cont)

196
197
198
199
200
201
202
203
204
205
206
207
208
209
210
211
212
213
214
215
216
217
218
219
220
221
222
223
224
225
226
227
228
229
230
231
232
233
234
235
236
237
238
239
240
241
242
243
244
245
246
247
248
249
250
251
252
253
254
255
256
257
258
259
260

WIRING DIAGRAM FOR MOD. GAS FURNACE (HEAT PUMP)

Calibration and Setup

- Set the INPUT RANGE jumper to the correct position for the signal to be used (0-15 V).
- Set the deadband jumper to the desired value (3%). This can be changed at any time with the power on.
- Connect the power supply and the input signal to the correct terminals.
- Turn on the power and the POWER LED will light.
- Apply an input signal equal to the R1 setpoint (0.5V).
- Adjust the R1 pot clockwise until the RELAY1 LED goes out, then slowly adjust the R1 pot counterclockwise until the LED just lights.
- Test the operation by increasing the input signal and watch as R1 turn on at the selected setpoints. Then decrease the signal and watch as the relays turn off at the selected setpoints minus the deadband.

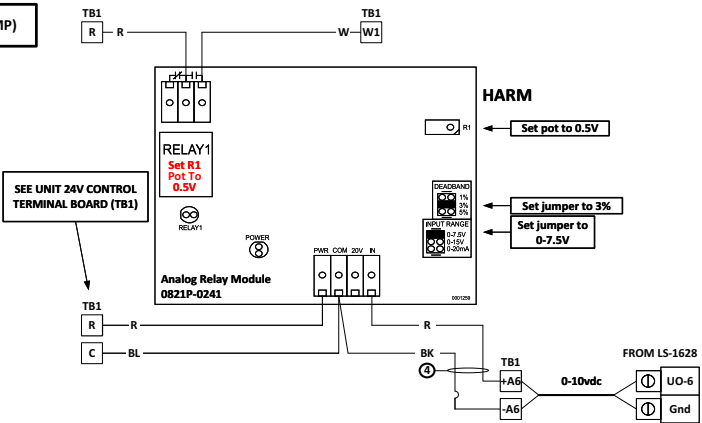

Fig. 100 — Typical Wiring Diagram (cont)

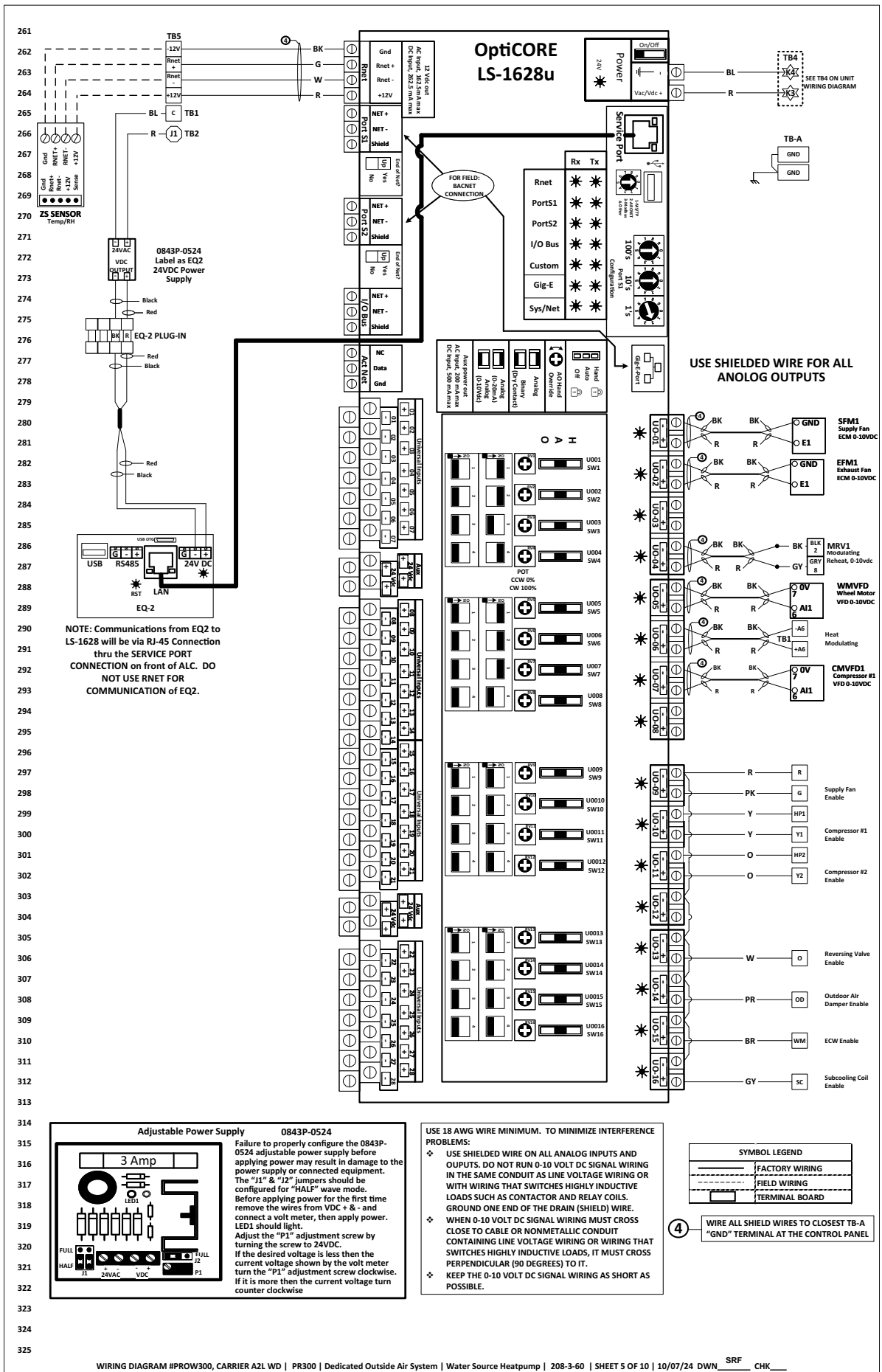

Fig. 100 – Typical Wiring Diagram (cont)

SENSORS	Line #	DESCRIPTION
CFI	383	Clogged Filter Indicator
COS	385	Condensate Overflow Switch
DXLAT1, DXLAT2	345, 347	Dx Leaving Air Temperature #1, #2
ECA-T/RH	327	Entering Coil Air - Temperature & Humidity
EF-AMS	351	Exhaust Fan - Air Monitoring Station
OAT	335	Outside Air Temperature
RAT	337	Return Air Temperature
SA-T/RH	331	Supply Air - Temperature & Humidity
SD-S	387	Field Installed Smoke Detector
SF-AMS	349	Supply Fan - Air Monitoring Station
WEXAT	339	Wheel Exhaust Air Temperature
ZS SENSOR	268	ZS Room Sensor

1 Note: THE SUPPLY/DISCHARGE AIR TEMPERATURE/RELATIVE HUMIDITY (SA-T/RH) IS FACTORY SUPPLIED FOR FIELD INSTALLATION IN SUPPLY AIR DUCT. SENSOR MUST BE INSTALLED DOWNSTREAM OF HEATER WHERE IT CANNOT "SEE" ANY HEATING ELEMENTS AND WHERE SUFFICIENT MIXING OF DISCHARGE AIR OCCURS. USE 18 AWG SHIELDED WIRE. DO NOT RUN SENSOR WIRING IN THE SAME CONDUIT AS LINE VOLTAGE WIRING OR WITH WIRING THAT SWITCHES HIGHLY INDUCTIVE LOADS SUCH AS CONTACTOR AND RELAY COILS.

2 Install OAT under the OA hood, sensing the ambient temp.
 3 Install ECA-T/RH after the ECW, sensing the modified temp/humidity.

4 WIRE ALL SHIELD WIRES TO CLOSEST TB-A or TB-D "GND" TERMINAL AT THE CONTROL PANEL

ALL FIELD INSTALLED SENSORS SHOULD BE WIRED TO THE CONTROLLER FOR FACTORY TESTING WITH TEMPORARY WIRING AND LEFT IN THE UNIT AFTER TEST. TEMPORARY WIRING SHOULD BE REMOVED FOR PERMANENT INSTALLATION DURING UNIT INSTALLATION. LABEL SENSORS PER THE WIRING DIAGRAM.

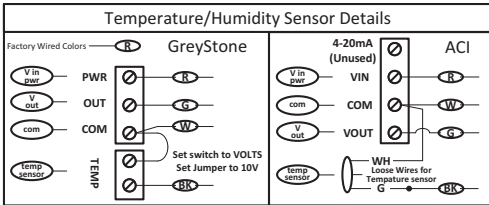

Adjustable Current Switch Adjustment

ECM Motors
 With the ALC off (power must be supplied to the motor), turn the potentiometer clockwise until the "RED LED" is lit. Turn the potentiometer counter-clockwise until the "RED LED" turns off and the "BLUE LED" is lit. Please note that with very small loads the "BLUE LED" will be very dim.

AC Motors and Compressors
 With the motor or compressor on and at its lowest speed turn the potentiometer clockwise until the "RED LED" is lit.

If the "RED LED" fails to turn on while the motor is in operation and the current switch is at its lowest adjustment additional wraps of wire may be needed.

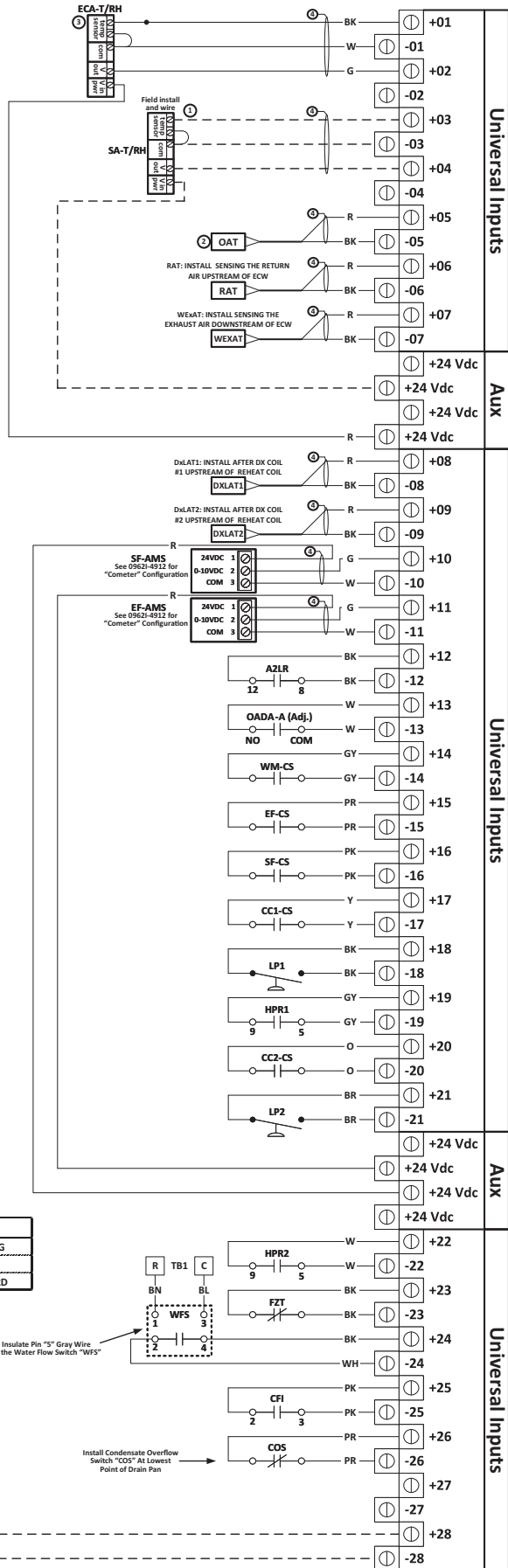
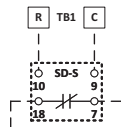
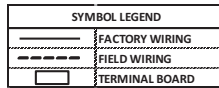

Fig. 100 – Typical Wiring Diagram (cont)

LEGEND - ITEMS INSIDE CONTROL PANEL			
ITEM	FUNCTIONAL DESIGNATION	LINE NUMBER	DESCRIPTION
101	CC1-CS	363	Compressor #1 - Current Switch
102	CC2	119	Compressor Contactor no. 2
103	CC2-AUX1	#	CC2 - Auxiliary Contact no. 1
104	CC2-CS	369	Compressor #2 - Current Switch
105	CHC1	101	Crankcase Heater Contactor #1
106	CHC1-AUX1	#	CHC1 - Auxiliary Contact no. 1
107	CMVFD1	1,92,292	Compressor #1 VFD
108	CR1	100	A2L Relay#1
109	EF-CS	359	Exhaust Fan - Current Switch
110	EFR	149	Exhaust Fan Relay
111	EGB	4	Equipment Grounding Bar
112	HARM	247	Heat Analog Relay Module
113	HPR1, HPR2	98, 117	High Pressure Relay #1, #2
114	HR		Heat Relay
115	MSP-CC2	11	Motor Starter Protection - CC2
116	PDB	1,456	Power Distribution Block
117	PM	59,68,68,71	Power/Phase Monitor
118	RVR	89	Reversing Valve Relay
119	SF-CS	361	Supply Fan - Current Switch
120	SFR	146	Supply Fan Motor Relay
121	SSR	132	Switchable Subcooling relay
122	WIR	611	Water Interlock Relay
123	WM-CS	357	Wheel Motor - Current Sensor
124	WMR	175	Wheel Motor Relay
125	WVFD	55,55,288	Wheel Motor Variable Frequency Drive

SEE LINE NUMBER TO THE RIGHT OF CONTACTOR COIL ON WIRING DIAGRAM.

LEGEND - ITEMS OUTSIDE CONTROL PANEL			
ITEM	FUNCTIONAL DESIGNATION	LINE NUMBER	DESCRIPTION
101	CCH1	4	Crankcase Heater #1
102	CCH2	14	Crank Case Heater #2
103	CM1	2	Compressor Motor No.1
104	CM2	12	Compressor Motor No.2
105	COPM #1	100,126	Compressor Overload Protection Module #1
106	COPM #2	119,128	Compressor Overload Protection Module #2
107	EFM1	45,48,282	Exhaust Fan Motor #1
108	FZT	379	Condensor Water Freezestat
109	HP1	98	High Pressure Switch #1
110	HP2	117	High Pressure Switch #2
111	LP1	365	Low Pressure Switch #1
112	LP2	371	Low Pressure Switch #2
113	LSS1A, LSS1B	133,134	Liquid Sub-Cooling Solenoid no. 1A, 1B
114	LSS2A, LSS2B	135,136	Liquid Sub-Cooling Solenoid no. 2A, 2B
115	MRV1	155	Modulating Reheat Valve #1
116	OADA	149,187,355	Outside Air Damper Actuator
117	RADA	188	Return Air Damper Actuator
118	RVS1, RVS2	89,87	Reversing Valve #1, #2
119	SFM1	31,40,280	Supply Fan Motor #1
120	WFS	380	Water Flow Switch
121	WM	56	Wheel Motor

SYMBOL LEGEND	
	FACTORY WIRING
	FIELD WIRING
	EARTH GROUND
	CHASSIS (PANEL) GROUND
	COIL
	NORMALLY OPEN CONTACTS
	NORMALLY CLOSED CONTACTS
	IDENTIFIABLE TERMINAL
	NON-IDENTIFIABLE TERMINAL, OTHER WIRE JUNCTIONS, INCLUDING SCHEMATIC

WIRE COLOR LEGEND	
ABBREVIATION	COLOR
BK	BLACK
BL	BLUE
BR	BROWN
G	GREEN
O	ORANGE
PK	PINK
PR	PURPLE
R	RED
W	WHITE
Y	YELLOW

NOTE: NUMBER PLACED AFTER DASH FOLLOWING COLOR CODE INDICATES WIRE GAGE. EX. - BK-12 IS A BLACK, 12 AWG WIRE.
NO NUMBER AFTER COLOR CODE INDICATES 18 AWG WIRE. EX. - BK IS A BLACK 18 AWG WIRE.

FUSE TABLE						
FUSE NO.	CLASS	VAC	AMPS-208/230V	AMPS-460V	XFMR	TIME DELAY
F1, F3	CC	600	3	2	350VA	YES
	CC	600	2	1.5	250VA	YES
	CC	600	2	1.5	200VA	YES
	CC	600	1.5	3/4	150VA	YES
F2, F9, F10	CC	600	1	1	N/A	YES
	CC	600	16	16	350VA	YES
	CC	600	10	10	250VA	YES
	CC	600	10	10	200VA	YES
	CC	600	6	6	150VA	YES

- 1) FIELD POWER SUPPLY 208/230/460/575-3-60. MINIMUM CIRCUIT AMPACITY AND MAXIMUM SIZE AND TYPE OF BRANCH-CIRCUIT SHORT-CIRCUIT AND GROUND-FAULT PROTECTION PER UNIT RATING PLATE. PROVIDE DISCONNECTING MEANS AS REQUIRED.
- 2) TYPICAL MOTORS AND COMPRESSORS SHOWN. SEE CONNECTION DIAGRAM ON MOTOR OR COMPRESSOR FOR ACTUAL WIRING DETAIL.

5) SET TIME DELAY PERIOD TO 5-MINUTES. UPON INITIAL APPLICATION OF POWER TO "TD", CONTACTOR "CC" IS ENERGIZES AFTER A 5-MINUTE START DELAY. WHEN POWER IS REMOVED, A LOCKOUT CONDITION AND 5-MINUTE TIME DELAY PERIOD (ADJUSTABLE) IS INITIATED. DURING THIS PERIOD, CONTACTOR "CC" CANNOT BE ENERGIZED.

8) WRAP WIRE THREE TIMES THRU CURRENT SENSOR IF WIRE IS 14 GAUGE. WRAP WIRE TWO TIMES THRU CURRENT SENSRO IF WIRE IS 12 GAUGE.

Fig. 100 — Typical Wiring Diagram (cont)

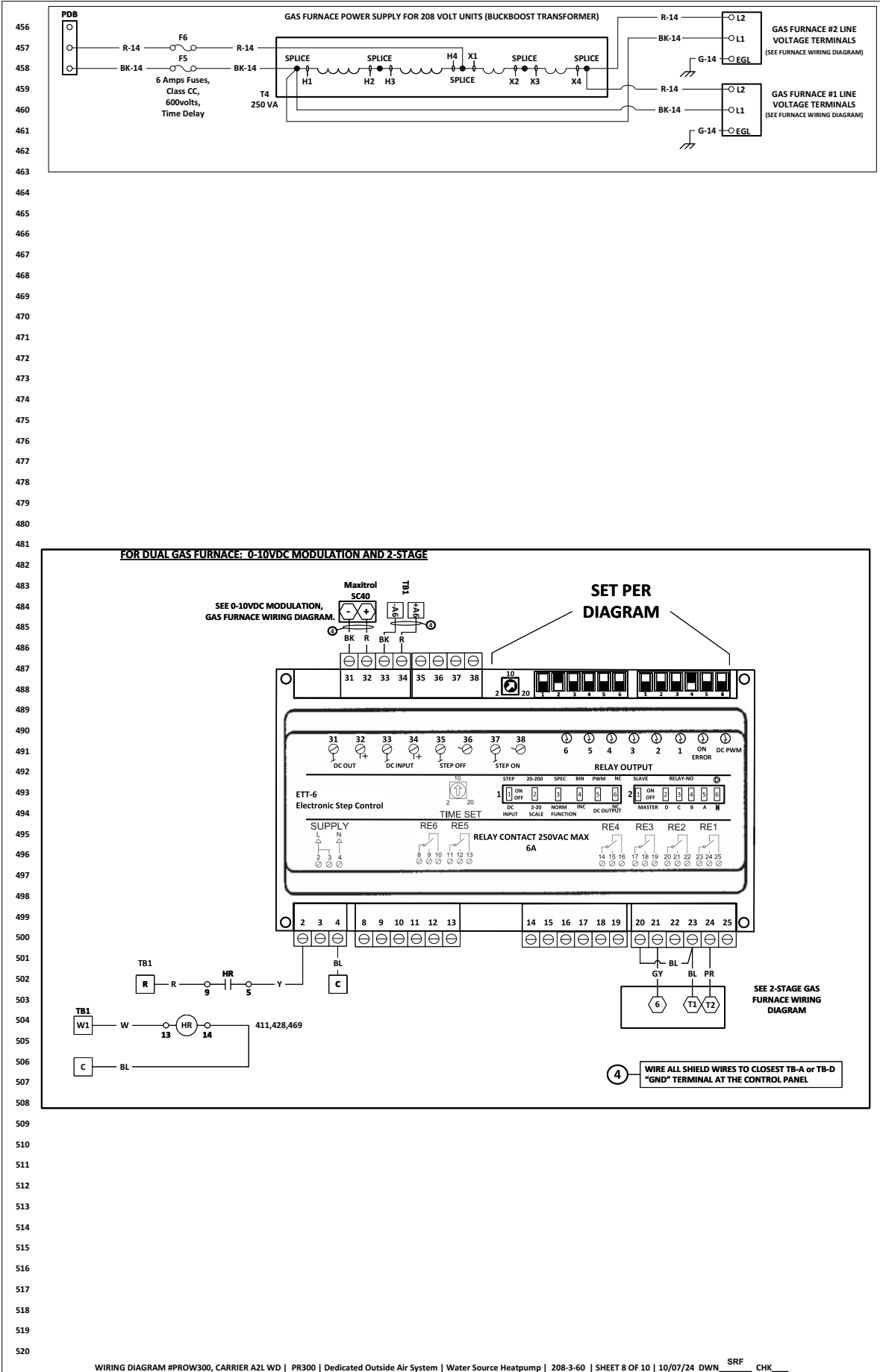
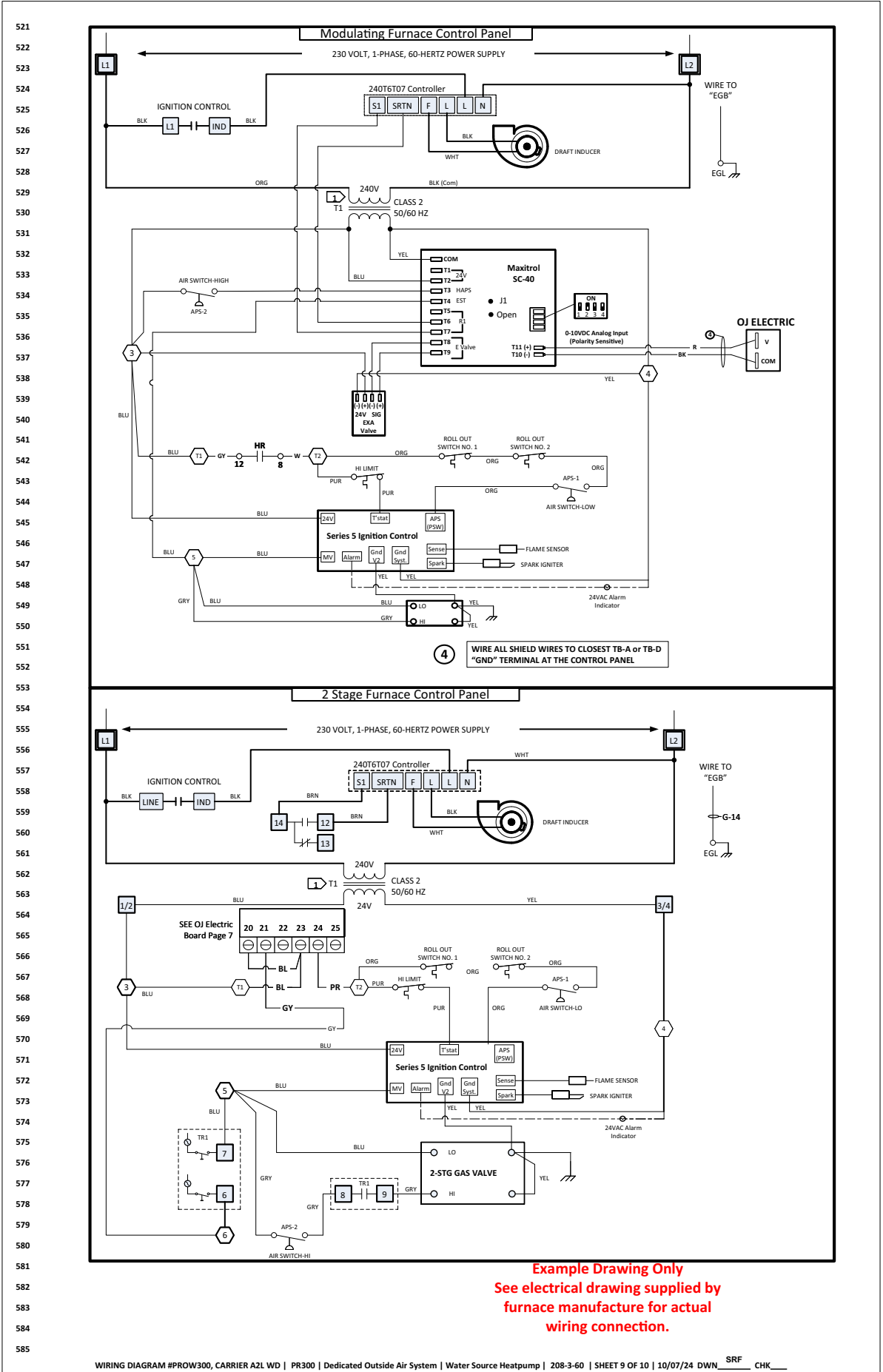

Fig. 100 — Typical Wiring Diagram (cont)



Example Drawing Only
See electrical drawing supplied by
furnace manufacturer for actual
wiring connection.

Fig. 100 — Typical Wiring Diagram (cont)

586
587
588
589
590
591
592
593
594
595
596
597
598
599
600
601
602
603
604
605
606
607
608
609
610
611
612
613
614
615
616
617
618
619
620
621
622
623
624
625
626
627
628
629
630
631
632
633
634
635
636
637
638
639
640
641
642
643
644
645
646
647
648
649
650

Wiring Diagram for Head Pressure Control of Water Regulating Valve Actuator – Dual Circuit

WIRING DIAGRAM #09621-4532, Rev. F | Water Regulator Valve Actuator – Dual Circuit, 24V | 07/24/13

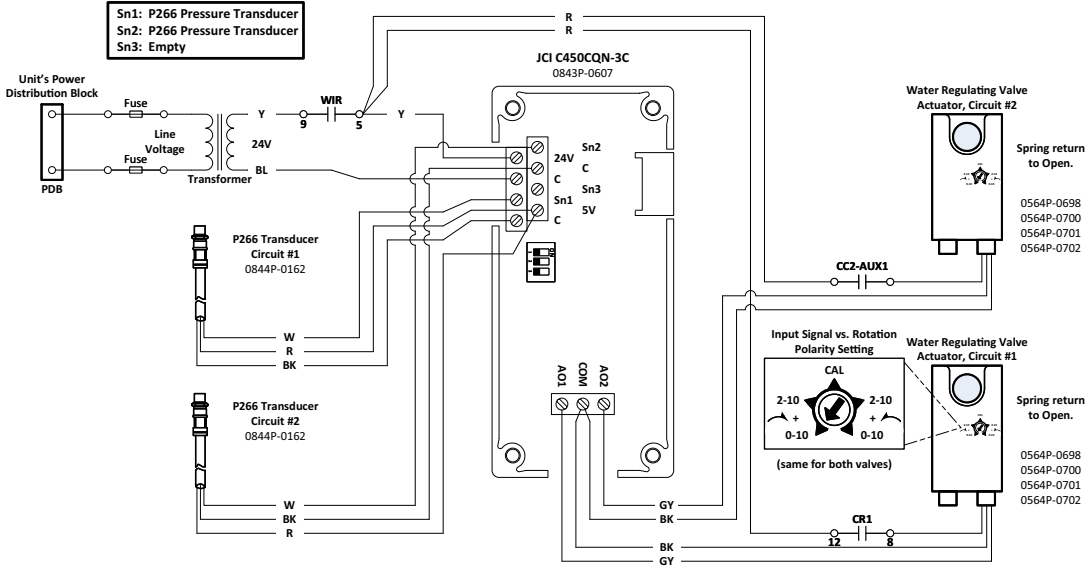

System 450 Set-Up for Water Head Pressure – Dual Circuit

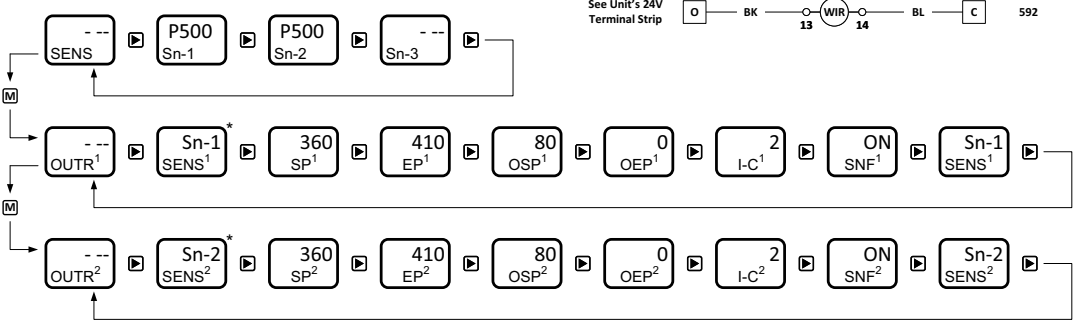

* - This screen will not show if sensor is already selected.

- System 450 Controller Programming Instructions:**
- Set all dip switches to "OFF" position. Apply 24VAC power.
 - Press and hold [▲] and [▼] simultaneously for 5 seconds to access "SENS" set-up screens.
 - Press [▶] for "Sn-1". Use [▲] or [▼] to select "P500" sensor. Press [▶] for "Sn-2". Use [▲] or [▼] to select "P500" sensor. Press [▶] then press [M].
 - Press [M] to access "OUTA" set-up.
 - Press [▶] for "SENS¹". Press [▲] or [▼] to set value to "Sn-1".*
 - Press [▶] for "SP¹". Press [▲] or [▼] to set value to "360".
 - Press [▶] for "EP¹". Press [▲] or [▼] to set value to "410".
 - Press [▶] for "OSP¹". Press [▲] or [▼] to set value to "80".
 - Press [▶] for "OEP¹". Press [▲] or [▼] to set value to "0".
 - Press [▶] for "I-C¹". Press [▲] or [▼] to set value to "2".
 - Press [▶] for "SNF¹". Press [▲] or [▼] to set value to "ON".
 - Press [▶] for "SENS²". Press [▲] or [▼] to set value to "Sn-1".
 - Press [M] to return to "OUTA" screen.
 - Press [▶] to access "OUTA²" set-up.
 - Press [▶] for "SENS²". Press [▲] or [▼] to set value to "Sn-2".
 - Repeat steps 6 thru 11 for the "OUTA" settings.
 - Press [▶] for "SENS²". Press [▲] or [▼] to set value to "Sn-2".
 - Press [M] to return to "OUTA" screen.
 - Press [▲] and [▼] simultaneously to return to the main screen.
- The controller is now programmed and ready to use.

* - This screen will not show if sensor is already selected.

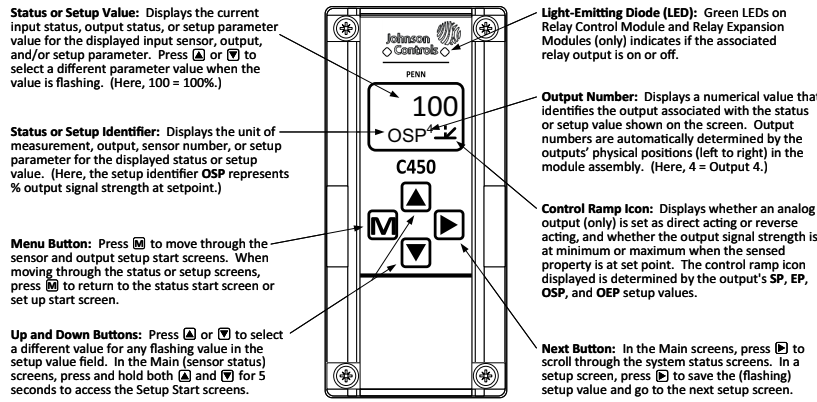

Fig. 100 – Typical Wiring Diagram (cont)

LEGEND FOR FIG. 100

APS	— Supply Air Differential Pressure Switch
BCTL	— Blower Compartment High Temperature Limit
BOS1	— Bleed off Solenoid #1 for HGRH
C450	— Johnson Control C450
CB	— Circuit Breaker
CC1	— Compressor Contactor No. 1
CC1-A	— Compressor Contactor No. 1 Auxiliary Contact
CC2	— Compressor Contactor No. 2
CC2-A	— Compressor Contactor No. 2 Auxiliary Contact
CCH	— Compressor Crankcase Heater
CM1	— Compressor No. 1
CM2	— Compressor No. 2
COPM	— Compressor Overcurrent Protection Module
CS	— Compressor Current Sensor Board
DCM	— Digital Compressor Module
DPT-260	— Differential Pressure Transmitter 260
ERV	— Energy Recovery Ventilator
EFC	— Exhaust Fan Contactor
EFM	— Exhaust Fan Motor
EFR	— Exhaust Fan Motor Relay
EGB	— Equipment Grounding Bar
EGL	— Earth Ground Loop
F	— Fusing
FS	— Flow Switch
HAR	— Heating Analog Relay
HARM	— Heating Analog Relay Mode
HF	— High Fire
HR	— Heat Relay
HP	— High Pressure Cutout
LA	— Low Ambient Fan Cycling Control
LP	— Low Pressure Cutout
LSS	— Liquid Sub-Cooling Solenoid
MDC	— Modulating Discharge - Line Controller
MDV	— Modulating Discharge Valve
MRC	— Modulating Reheat Temperature Control Board
MRV	— Modulating Hot Gas Reheat Valve
MSP-CC	— Motor Starter Protection - Compressor Contactor
MSP-EF	— Exhaust Blower Motor Starter Protector
MSP-OF	— Motor Starter Protection - Outdoor Fan
MSP-SF	— Motor Starter Protection - Supply Fan
MSP-WM	— Motor Starter Protection - Wheel Motor
OADA	— Two Position Outdoor Air Damper Actuator
OAT	— Outdoor Air Temperature Sensor
OFC	— Outdoor Fan Contactor
OFM	— Outdoor Fan Motor
PDB	— Power Distribution Block
PM	— Power Monitor
RAT	— Return Air Temperature Sensor
RHLGP	— High/Low Gas Pressure Switch
RHR	— Reheat Relay
RHS	— Hot Gas Reheat Solenoid Valve
SCR	— Silicon Controlled Rectifier
SFC	— Supply Fan Motor Contactor
SFM	— Supply Fan Motor
SFR	— Supply Fan Motor Relay
T	— Control Transformer
TB	— Terminal Board
VFD	— Variable Frequency Drive
WBDA	— Wheel Bypass Damper Actuator
WMC	— Wheel Motor Contactor
WM	— EC Wheel Motor
WMC	— Wheel Motor Contactor

APPENDIX A — BAS COMMISSIONING

The OEM controller in the 62W unit can communicate with most building automation systems (BAS) using BACnet. Follow the guide below for integration instructions.

NOTE: The 62W unit utilizes an OEM controller and is considered a third party device when integrating with Carrier's i-Vu® Open system. In order for the 62W unit to communicate with the i-Vu Open system, the 62W unit must be connected to an i-Vu Link and the i-Vu server must be an i-Vu Open Plus.

BACnet

BACnet, which stands for Building Automation and Controls network, is a protocol developed by ASHRAE (American Society of Heating, Refrigerating, and Air-Conditioning Engineers). BACnet was developed as a response to industry concerns about increased networking of BMS (building management system) components using proprietary communications methods. In the past, these proprietary communications severely limited the building owners' choices for system expansion, upgrade, and replacement. Every major controls vendor in North America, as well as academics, end users, consulting engineers, and government groups participated in its development.

BACnet has been accepted as an open standard by the American National Standards Institute (ANSI) and the European CEN standards. It is also being adopted as an international ISO standard.

BACnet is designed to include all building systems, lighting, security, fire, heating, ventilation, and air conditioning. Its purpose is to promote interoperability - sharing data between systems made by different vendors.

It provides the necessary tools to develop a specification for systems that are interoperable. BACnet provides methods and standards for representing information, for requesting and interpreting information, and for transporting information.

Addressing the LS-1628u Controller

1. Connect an Ethernet cable from a computer to the controller's Service Port, as shown below.
NOTE: Be sure NOT to plug the cable into the Gig-E Port.
2. Turn off the computer's Wi-Fi if it is on.
3. If your computer uses a static IP address, use the following settings:
 - a. Address: 169.254.1.x, where x is 2 to 7
 - b. Subnet Mask: 255.255.255.248
 - c. Default Gateway: 169.254.1.1If it uses a DHCP address, leave the address as it is.
4. Open a web browser on the computer.
5. Navigate to <http://local.access> or <http://169.254.1.1> to see the controller set-up pages.

Setting up AUTOBAUD

The LS-1628u controller does not use any dip switches or jumpers as previous ALC controllers have to set baud rate and comm configuration.

The LS-1628u controller can automatically receive or establish the baud rate on a serial network. When you configure a device on the network for autobaud and then power it up, the device detects the incoming baud rate on the network and sets its baud to match.

Autobaud does not work unless there is a device on the network, whether OEMCtrl or third-party, that has the baud rate already set. You can manually set the baud rate on more than one device, as long as the rate is the same for every device. See Fig. A for configuration options.

NOTE: The received baud rate stays intact during power cycles. It is recommended to set the baud rate manually on the router for the network.

MS/TP

MS/TP Autobaud can be configured in either the:

1. Service Port Controller set-up pages > BACnet Tab > Port S1 or Port S2 or
2. The WebCTRL interface, on the Network tree, select your LS-1628u > Driver > BACnet Router Properties > MS/TP Configuration on Port S1 or on Port S2.

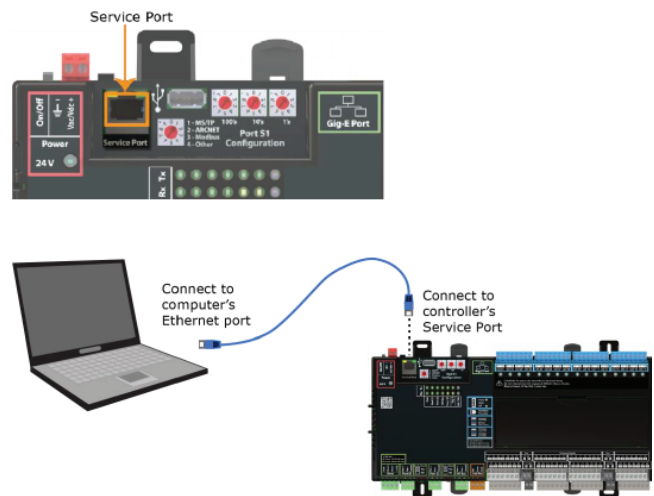

Fig. A — Autobaud Configuration Options

APPENDIX A — BAS COMMISSIONING (cont)

BACnet MS/TP

BACnet MS/TP is used for communicating BACnet over a sub-network of BACnet-only controllers. Each controller on the network has the ability to hear the broadcast of any other device on the network. The speed of an MS/TP network ranges from 9600 baud to 76.8k baud.

CONFIGURING THE LS-1628U CONTROLLER FOR BACNET MS/TP

1. Turn off the LS-1628u controller's power.
2. Check the communications wiring for shorts and grounds.
3. Connect the communications wiring to the Port S1 or Port S2 screw terminals labeled Net +, Net -, and Shield.
NOTE: Use the same polarity throughout the network segment.
4. If you are using Port S1, set the Port S1 Configuration rotary switch to 1. If using port S2, you will do set up through the Service Port Page Set Up, under ports tab.
NOTE: If Port S1 is not being used for nay network, set this rotary switch to 0.
5. If the LS-1628u controller is at either end of a network segment, set the port's End of Net? switch to Yes.
NOTE: The controller's End of Net switch applies network termination and bias. If the controller is at the end of a network segment that includes a DIAG485 that has its Bias jumper in the ON position, set the End of Net? switch to No and connect a 120 ohm termination resistor to the Net+ and Net- terminals. See *DIAG485 Technical Instructions* for more information.
6. Turn on the controller's power.
7. To verify communication with the network, get a Module Status report in the WebCTRL interface for a controller on the MS/TP network.
NOTE: This step requires that you have set up the router in the SiteBuilder and downloaded it from the WebCTRL interface.

SETTING UP THE IP ADDRESS ON LS-1628U CONTROLLER

You must define the LS-1628u controller's IP addressing (IP address, subnet mask, and default gateway) in the controller set up pages so that the controller can communicate with the WebCTRL Server on the IP network. This IP addressing must match the IP addressing defined in SiteBuilder in the controller's Properties dialog box.

Use one of the IP addressing schemes described below with the associated instructions that follow.

Use a...	If...
DHCP IP Address generated by a DHCP server	The IP network uses a DHCP server for IP addressing
Custom Static IP Address from your network administrator	You do not use a DHCP server and the answer to any of the following questions is yes. Will the WebCTRL system: <ul style="list-style-type: none"> • Share a facility's existing IP data network? • Have 254 or more devices with static IP addresses? • Be connected to the Internet? • Have at least one device located on the other side of an IP router? • Have any third-party IP devices?
Default IP Address that your system creates	The answers to all of the above questions is no

SETTING A DHCP IP ADDRESS

1. On the controller set up Modstat tab, find the controller's Ethernet MAC address and write it down.
2. On the Ports tab under IP Port, select DHCP.
3. Click Save.
4. Write down the IP Address.
5. Give the DHCP network administrator the IP address and Ethernet MAC address and ask him to reserve that IP address for the controller so that it always receives the same IP address from the DHCP server.

TO SET A CUSTOM IP ADDRESS

1. Obtain the IP address, subnet mask, and default gateway address for the controller from the facility network administrator.
2. On the controller set up Ports tab under IP Port, select Custom Static.
3. Enter the IP Address, Subnet Mask, and Default Gateway addresses that the network administrator gave you.
4. Click Save.

TO SET A DEFAULT IP ADDRESS

Default IP addressing assigns the following to the controller:
 IP Address = 192.168.168.x where x is the setting on the rotary switches in the range from 1 to 253
 Subnet Mask = 255.255.255.0
 Default Gateway = 192.168.168.254

1. Set the controller's three rotary switches to a unique address on the network. Set the left rotary switch to the hundreds digit, the middle switch to the tens digit, and the right switch to the ones digit.

EXAMPLE The switches below are set to 125

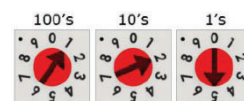

2. On the controller set up Ports tab under IP Port, select Default IP Address.
3. Click Save.

APPENDIX A – BAS COMMISSIONING (cont)

CAUTION

If you are using Port S1, the rotary switches also determine that network's address. Although the ARCNET address range is 1 to 255, the Default IP address range is 1 to 253. Setting the rotary switches to 0 will set the Default IP address to 1. Setting the switches to 255 will set the Default IP to 253. Do not set the switches to 254.

If you set the default IP address on the controller set up Ports tab, and then change the rotary switches, you must do one of the following to correct the IP address on the controller:

- Go to the controller set up Ports tab and click the Update IP Address.
- Cycle the controller's power.

You will then need to correct the IP address in SiteBuilder.

NOTE: The default address is an intranet address. Data packets from this address are not routable to the Internet.

TO SET THE PORT S2 ADDRESS AND BAUD RATE

The address should be in one of the following ranges based on the port's use.

- For MS/TP, the range is 0 to 127.

You set this address on the LS-1628u controller's three rotary switches. Set the left rotary switch to the hundreds digit, the middle switch to the tens digit, and the right switch to the ones digit.

FOR MS/TP, SET UP AUTOBAUD OR THE PORT'S BAUD RATE

1. On the controller set up BACnet tab under Port S1, select the MSTP Baud Rate or select Yes for MSTP Autobaud. The default is 76,800 bps.

NOTE: See "Setting up AUTOBAUD" on page 82 for set up details.

If not using autobaud, enter the identical baud rate for all devices on the same MS/TP network segment.

2. Click Save.

TO SET THE PORT S2 AND BAUD RATE

For MS/TP, set up autobaud or the port's baud rate.

1. On the controller set up BACnet tab under Port S2, type the address in the MS/TP Address field. The address must be in the range 0 to 127.
2. Select the MSTP Baud Rate or select Yes for MSTP Autobaud. The default is 76,800 bps.
NOTE: See "Setting up AUTOBAUD" on page 82 for set up details.
If not using autobaud, enter the same baud rate for all services on the MS/TP network.
3. Click Save.

Table A – Wiring Specifications for Communications

Ethernet	Cat5e or higher Ethernet cable	Max length: 328 ft (100m)
----------	--------------------------------	---------------------------

TO CONNECT THE LS-1628U CONTROLLER TO THE ETHERNET

Connect an Ethernet cable to the Gig-E Ethernet port located on the top of the LS-1628u controller. Be careful NOT to plug your cable into the Service Port (located on front of Controller).

NOTE: If your system has controllers on different IP subnets separated by an IP router, you must configure one controller on each subnet as a BACnet Broadcast Management Device (BBMD). Do not configure more than one BBMD per subnet as this may cause circular routes. See "Setting up BACnet Broadcast Management Devices (BBMDs)" in SiteBuilder or WebCTRL Help. See Fig. for Gig-E port location.



Fig. B – Gig-E Port Location

Table B – Wiring for Communications: LS-1628u Controller

PORT	PROTOCOL	PORT TYPE(S)	SPEED(S)
GIG-E	BACnet/IP BACnet/Ethernet	Ethernet	10, 100, or 1000 Mbps (1Gbps)
PORT S1 1 OR PORT S2	BACnet/MSTP	RS485	9.6 to 115.2 kbps 2
SERVICE PORT 3	HTTP/IP	Ethernet	10 Mbps or 100 Mbps
USB PORT	USB2.0	USB	—
RNET PORT	<i>Wiring devices to the LS-1628u controller's Rnet port</i>		
I/O BUS PORT	<i>To attach LS-XP expanders</i>		

NOTE: Set the Port S1 Configuration rotary switch to:

0 if port is not used

1 for MS/TP

4 is for future use.

Default baud rate for MS/TP is 76.8 kbps.

APPENDIX A — BAS COMMISSIONING (cont)

TO WIRE TO A BACNET MS/TP NETWORK

An MS/TP network can be wired to either Port S1 or Port S2.

1. Turn off the LS-1628u controller's power.
2. Check the communication wiring for shorts and grounds.
3. Connect the communications wiring to the Port S1 or Port S2 screw terminals labeled Net+, Net-, and Shield.

NOTE: Use the same polarity throughout the network segment.

4. If you are using Port S1, set the Port S1 Configuration to switch to 1.

NOTE: If Port S1 is not being used for any network, set this rotary switch to 0.

5. If the LS-1628u controller is at either end of a network segment, set the port's End of Net? switch to Yes.

NOTE: The controller's End of Net switch applies network termination and bias. If the controller is at the end of a network segment that includes a DIAG485 that has its Bias jumper in the ON position, set the End of Net? switch to No and connect a 120 ohm termination resistor to the Net+ and Net- terminals. See DIAG485 Technical Instructions for more information.

6. Turn on the controller's power.

7. To verify communication with the network, get a Module Status report in the WebCTRL interface for a controller on the MS/TP network.

NOTE: This step requires that you have set up the router in SiteBuilder and downloaded it from the WebCTRL interface.

APPENDIX A – BAS COMMISSIONING (cont)

Table C – Mapping Points - Carrier 62W Rev. K - 100% Outdoor Air

DISPLAY NAME	READ/ WRITE	BACNET			DESCRIPTION
		REFERENCE NAME	TYPE	ID	
Alarm Reset	R/W	alarm_reset	BV	900	Read/write point to Reset Alarms.
Alarm Status	R	alarm_status	BV	851	The current Alarm Status of Unit.
Allow Compressor Disable	R/W	comp_dis	BV	539	Read/write point that Allows Compressor Disable on Low Supply Fan % or Low OAT.
Allow Zone Set Point Adjust	R/W	zat_sp_adj_en	BV	202	This point will enable the Zone set point adjustment on the zone sensor (Default is plus or minus 5°F).
Aux. Htg. Enable	R	ahtg_en	BV	580	The current Auxiliary Heating Enable Status.
BAS Com Lost OAT/OARH Status	R	bas_com_lost_on	BV	1102	BAS communication lost code. This point displays the status of the lost of communication for the OAT/OARH option.
BAS Comm. Lost Delay	R/W	bas_comm_lost_delay	AV	103	BAS communication lost code. Delay on Make timer (Default 60 seconds). The input must change state within time period.
BAS Communication Lost	R	bas_comm_lost	BV	107	BAS communication lost code. This point displays the status of the lost of communication for the schedule option.
BAS LOST	R	bas_comm_lost_alarm	BV	899	The current BAS Lost Alarm for Schedule Option.
BAS Manual Occ Control	R/W	occ_en	BV	101	Read/write point will place the unit into unoccupied/occupied mode with Occupancy Control Option is set to BAS Control.
C1 ALARM	R	c1_alarm	BV	863	The current Compressor #1 Alarm Status.
C1 Command	R	c1_cmd	BV	243	Compressor #1 Start Command (BO-2).
C1 Freeze Status	R	c1_freeze_stat	BV	555	The current Compressor #1 Freeze Status.
C1 HAND	R	c1_hand_alarm	BV	873	The current Compressor #1 Hand Alarm Status.
C1 STOP	R	c1_stop_alarm	BV	864	The current Compressor #1 Stop Alarm Status.
C1/C2 Stop Disables Unit	R/W	c1c2_stop_disables_unit	BV	847	Read/write to Enable the Unit to shutdown if compressors in Stop Alarm.
C1DIG Percentage Before C2 SP	R/W	dig1_pct_c2_sp	AV	6402	Read/write point for Compressor #1 demand for Compressor #2 Start (Default is 95%).
C2 ALARM	R	c2_alarm	BV	877	The current Compressor #2 Alarm Status.
C2 Command	R	c2_cmd	BV	244	Compressor #1 Start Command (BO-3).
C2 Freeze Status	R	c2_freeze_stat	BV	556	The current Compressor #2 Freeze Status.
C2 HAND	R	c2_hand_alarm	BV	887	The current Compressor #2 Hand Alarm Status.
C2 STOP	R	c2_stop_alarm	BV	878	The current Compressor #2 Stop Alarm Status.
CFI ALARM	R	cfi_alarm	BV	893	The current Clogged Filter Indicator Alarm Status.
CFI Status	R	cfi_stat	BV	232	Clogged Filter Indicator Switch Status (N.O.).
Clg #1 Enable SP	R/W	clg1_en_sp	AV	307	The set point for Cooling #1 Enable (Default varies).
Clg #2 Enable SP	R/W	clg2_en_sp	AV	327	The set point for Cooling #1 Enable. (Default varies).
Clg Modulation SP Occ	R/W	clg_mod_sp_o	AV	375	The set point for Occupied Cooling Modulation. (Default is 55°F).
Clg SAT SP Occ	R/W	clg_sat_sp_o	AV	313	The set point for Occupied Cooling Supply Air Temperature (Default varies).
Clg SAT SP Unocc	R/W	clg_sat_sp_u	AV	314	The set point for Unoccupied Cooling Supply Air Temperature (Default varies).
CO2 Dead Band	R/W	co2_db	AV	217	The CO ₂ Upper Deadband for High CO ₂ Alarm (Default 200 ppm)
CO2 FAIL	R	co2_failure	BV	854	The current CO ₂ Sensor Alarm status.
CO2 From BAS	R/W	co2_bas	AV	213	The current Carbon Dioxide reading (CO ₂) written to the controller by the BAS system.
CO2 Occupancy Status	R	co2_occ_stat	BV	203	This point will display the status for the CO ₂ enable for schedule control for the CO ₂ option.
CO2 Set Point #1	R/W	co2_sp1	AV	215	The CO ₂ set point for Occupancy Control. (Default 300ppm).
CO2 Set Point #2	R/W	co2_sp2	AV	216	The CO ₂ set point for High CO ₂ Alarm (Default 1200ppm).
CO2 Status	R	co2_stat	AV	214	The current Zone Carbon Dioxide reading (CO ₂) from the Zs sensor.
Comp #1 CS Status	R	cc1_cs_stat	BV	224	Compressor #1 Current Sensor Status.
Comp #2 CS Status	R	cc2_cs_stat	BV	227	Compressor #2 Current Sensor Status.
Compressor Disable SP	R/W	comp_dis_sp	AV	541	The set point for Outside Air Temperature Compressor Disable (Default is 32°F).
Compressor Disabled by OAT	R	comp_dis_oat	BV	540	The current Compressor Disabled Status.
Condensate Overflow Switch	R	cos_stat	BV	233	Condensate Overflow Switch Status (N.C.).
Cooling #1 Enable	R	clg1_en	BV	551	The current Cooling #1 Enable Status.
Cooling #2 Enable	R	clg2_en	BV	552	The current Cooling #2 Enable Status.
COS ALARM	R	cos_alarm	BV	894	The current Condensate Overflow Switch Alarm Status.
CWV Action	R/W	cwv_action	BV	640	Read/write to set type of Chilled Water Valve (Default is N.O.)
CWV Percentage	R	cwv_pct	AV	288	The current Chilled Water Valve Modulation Status (UO-7 Percentage).
Dehumid. #1 Enable	R	dh1_en	BV	565	The current Dehumidification #1 Enable Status.
Dehumid. #2 Enable	R	dh2_en	BV	566	The current Dehumidification #2 Enable Status.
DH Mod. SP	R/W	dh_mod_sp	AV	346	The set point for Dehumidification Modulation (53°F or 53%)
DH Mode Low Limit	R/W	dh_llim	AV	344	The set point for Occupied Low Limit Dehumidification Temperature (Default is 60°F).
DH SAT SP Occ	R/W	dh_sat_sp_o	AV	341	The set point for Occupied Dehumidification Supply Air Temperature (Default is 70°F).

APPENDIX A – BAS COMMISSIONING (cont)

Table C – Mapping Points - Carrier 62W Rev. K - 100% Outdoor Air (cont)

DISPLAY NAME	READ/ WRITE	BACNET			DESCRIPTION
		REFERENCE NAME	TYPE	ID	
DH SAT SP Unocc	R/W	dh_sat_sp_u	AV	342	The set point for Unoccupied Dehumidification Supply Air Temperature (Default is 75°).
DH SP Occ	R/W	dh_sp_o	AV	337	The set point for Occupied Dehumidification #1 (Default is 55).
DH SP Unocc	R/W	dh_sp_u	AV	338	The set point for Unoccupied Dehumidification #1 (Default is 65).
DH1 Sensor Status	R	dh1_stat	AV	345	The current Dehumidification Sensor #1 Status
DH2 Sensor Status	R	dh2_sens_stat	AV	349	The current Dehumidification Sensor #2 Status
—	—	—	—	—	—
—	—	—	—	—	—
—	—	—	—	—	—
DR1 Status	R	dr1_stat	BV	256	Defrost Relay #1 Status in ASHP
DR2 Status	R	dr2_stat	BV	257	Defrost Relay #2 Status in ASHP
DX LAT #2 Status	R	dx_lat2_stat	AV	245	The current Leaving Air Temperature for Dx coil #2 (DXLAT2).
DX LAT Status	R	dx_lat_stat	AV	243	The current Leaving Air Temperature for Dx coil #1 (DXLAT).
DXLAT FAIL	R	dx_lat_failure	BV	843	The current DXLAT Sensor Alarm Status.
DXLAT2 FAIL	R	dx_lat2_failure	BV	844	The current DXLAT2 Sensor Alarm Status.
ECAT FAIL	R	ecat_failure	BV	831	The current ECAT Sensor Alarm Status.
ECAT Status	R	ecat_stat	AV	219	The current Entering Coil Air Temperature (ECAT).
ECON NOT	R	econ_not_fdd	BV	962	The current FDD Alarm is Economizing when it should not.
Econ. MAT SP	R/W	econ_mat_sp	AV	600	The set point for Economizer Mixed Air Temperature (Default is 65°F).
Econ. OAE SP	R/W	econ_oea_sp	AV	549	The set point for Economizer Outside Air Enthalpy (default is 22btu/lb).
Econ. OAT Upper SP	R/W	econ_oat_usp	AV	550	The set point for Economizer Outside Air Temperature (Default is 59°F).
ECRH FAIL	R	ecrh_failure	BV	832	The current ECAT Sensor Alarm Status.
ECRH Status	R	ecrh_stat	AV	221	Entering Coil Relative Humidity Sensor Status (ECRH).
ECW ALARM	R	ecw_alarm	BV	952	The current Energy Conservation Wheel Alarm Status.
ECW Command	R	ecw_cmd	BV	247	Energy Conservation Wheel Start Command (BO-7)
ECW CS Status	R	ecw_cs_stat	BV	222	Energy Conservation Wheel Current Sensor Status.
ECW Defrost ON	R	ecw_def_on	BV	514	The current Energy Conservation Wheel Defrost Status
ECW Enable	R	ecw_en	BV	513	The current Energy Conservation Wheel Enable Status (Default is 25°F).
ECW HAND	R	ecw_hand_alarm	BV	953	The current Energy Conservation Wheel Hand Alarm Status.
ECW VFD Frequency	R	ecwvfd_freq	AV	284	The current Energy Conservation Wheel VFD Status (UO-5 Frequency)
EF ALARM	R	ef_alarm	BV	860	The current Exhaust Fan Alarm Status.
EF AMS SP	R/W	ef_ams_sp	AV	305	The set point for Exhaust Fan Air Monitoring Station (Default is 2000cfm)
EF DPT SP	R/W	ef_dpt_sp	AV	302	The set point for Exhaust Fan Duct Pressure Transducer (Default is 1 in. of H ₂ O)
EF HAND	R	ef_hand_alarm	BV	861	The current Exhaust Fan Hand Alarm Status.
EF Modulation	R	efmod_pct	AV	287	The current Exhaust Fan Modulation Status (UO-2 Percentage).
EF OA AMS Status	R	ef_oea_ams_stat	AV	259	The current exhaust Fan, Supply Fan, or Outdoor Air Monitoring Station Status (UI-11).
EF PID Output Override	R/W	ef_pid_ovrd	AV	639	Read/write Exhaust Fan PID Output for CAV (Percentage).
EF PID Output Override Lock	R/W	ef_pid_ovrd_lock	BV	631	Read/write Exhaust Fan PID Output in Constant Air Volume (CAV) Status.
EF-APS or CS Status	R	ef_aps_stat	BV	221	Exhaust Fan Air Proving Switch or Current Sensor Status.
EM SHTDN	R	em_shtdn_alarm	BV	895	The current Emergency Shutdown Alarm Status.
Em. Htg. Enable	R	ehtg_en	BV	579	The current Emergency Heating Enable Status.
Emerg. Shutdown Enable	R/W	emsd_en	BV	821	The current Emergency Shutdown Enable Status.
Emergency Shutdown Status	R	emsd_status	BV	822	The current Emergency Shutdown Status.
EMR/EMSD Status	R	emrsd_stat	BV	234	Emergency Relay/ Emergency Shutdown Switch Status (N.C.).
Enable BAS Mon OAT/OARH	R/W	en_bas_mon_oea	BV	1100	Read/write point will Enables BAS Monitoring of OAT/OARH Sensors.
Enable BAS Monitor Schedule	R/W	en_bas_mon	BV	106	BAS communication lost code. Enables the code to allow the BAS control to change to the local schedule in the controller.
Enable FDD Alarms	R/W	fdd_alarm_en	BV	960	Read/write point to Enable FDD Alarms.
Entering Coil Air Dew Point	R	eca_dewpoint	AV	262	The current Entering Coil Air Dew Point Status
Entering coil Air Enthalpy	R	ec_enthalpy	AV	263	The current Entering Coil Air Enthalpy Status
EXCESS OA	R	excess_oea_fdd	BV	964	The current FDD Alarm is allow to much OA.
Field BAS Comm. Status	R/W	bas_comm_status	BV	110	BAS communication lost code. Read/write point must change state before BAS lost delay timer expires.
FP1 ALARM	R	fp1_alarm	BV	871	The current Freeze Protection #1 Alarm Status.
FP1 STOP	R	fp1_stop_alarm	BV	872	The current Freeze Protection #1 Stop Alarm Status.

APPENDIX A – BAS COMMISSIONING (cont)

Table C – Mapping Points - Carrier 62W Rev. K - 100% Outdoor Air (cont)

DISPLAY NAME	READ/ WRITE	BACNET			DESCRIPTION
		REFERENCE NAME	TYPE	ID	
FP2 ALARM	R	fp2_alarm	BV	885	The current Freeze Protection #2 Alarm Status.
FP2 STOP	R	fp2_stop_alarm	BV	886	The current Freeze Protection #2 Stop Alarm Status.
Freeze Protection LSP	R/W	fp_lsp	AV	323	The set point for Lower Compressor Freeze Lockout Protection (Default is 38°F).
Freeze Protection MSP	R/W	fp_msp	AV	322	The set point for Middle Compressor Freeze Lockout Protection (Default is 45°F).
Freeze Protection USP	R/W	fp_usp	AV	321	The set point for Upper Compressor Freeze Lockout Protection (Default is 55°F).
FRZ Status	R	frz_stat	BV	231	Freezestat Status in WSHP (N.C.).
FZT ALARM	R	fzt_alarm	BV	830	The current Water Freezestat Alarm status.
Heat Mod. Minimum Output	R/W	htg_mod_min	AV	677	Read/write Heating Minimum Output (Default is 0%)
Heat Modulation	R	htg_mod	AV	286	The current Heat Modulation Status (UO-6 Percentage)
Heat PID Output Override	R/W	htg_pid_ovrd	AV	678	Read/write Heating PID Output for CAV (Percentage).
Heat PID Output Override Lock	R/W	htg_pid_ovrd_lock	BV	671	Read/write Heating PID Output in Constant Air Volume (CAV) Status.
Heat Pump #1 Enable	R	hp1_en	BV	571	The current Heat Pump #1 Enable Status.
Heat Pump #2 Enable	R	hp2_en	BV	572	The current Heat Pump #2 Enable Status
Heating Supports Reheat	R/W	htg_rh_en	BV	563	Read/write point Enables heating to support HGRH.
HGRH Mod. Minimum Output	R/W	hgrh_mod_min	AV	668	Read/write HGRH Minimum Output (Default is 0%)
HGRH Modulation	R	hgrh_mod	AV	285	The current Hot Gas Reheat Modulation Status (UO-4 Percentage)
HGRH PID Output Override	R/W	hgrh_pid_ovrd	AV	669	Read/write HGRH PID Output for CAV (Percentage).
HGRH PID Output Override Lock	R/W	hgrh_pid_ovrd_lock	BV	661	Read/write HGRH PID Output in Constant Air Volume (CAV) Status.
HIGH CO2	R	high_co2_alarm	BV	826	The current High CO ₂ Alarm status.
High Supply DPT SP	R/W	high_sfdpt_sp	AV	804	The set point for High Supply Fan Duct Pressure Transducer Alarm (Default is 5 in. of H ₂ O).
HPS #1 Status	R	hps1_stat	BV	226	High Pressure Switch #1 Status.
HPS #2 Status	R	hps2_stat	BV	229	High Pressure Switch #2 Status.
HPS1 ALARM	R	hps1_alarm	BV	867	The current High Pressure Switch #1 Alarm Status.
HPS1 STOP	R	hps1_stop_alarm	BV	868	The current High Pressure Switch #1 Stop Alarm.
HPS2 ALARM	R	hps2_alarm	BV	881	The current High Pressure Switch #2 Alarm Status.
HPS2 STOP	R	hps2_stop_alarm	BV	882	The current High Pressure Switch #2 Stop Alarm.
HSAT ALARM	R	hsat_alarm	BV	892	The current High Supply Air Temperature Alarm Status.
HSDP ALARM	R	hsdp_alarm	BV	858	The current High Supply Duct Pressure Alarm Status.
HSDP STOP	R	hsdp_stop_alarm	BV	859	The current High Supply Duct Pressure Stop Alarm Status.
HT FAIL	R	heat_failure	BV	891	The current Heat Failure Alarm Status.
Htg Enable SP	R/W	htg_en_sp	AV	351	The set point for Heating #1 Enable. (Default is 55°F).
Htg Mode High Limit Set Point	R/W	htg_hlim	AV	360	The set point for Occupied High Limit Dehumidification Temperature (Default is 60°F).
Htg SAT SP Occ	R/W	htg_sat_sp_o	AV	354	The set point for Occupied Heating Supply Air Temperature (Default is 70°F or 90°F Recirc).
Htg SAT SP Unocc	R/W	htg_sat_sp_u	AV	355	The set point for Unoccupied Heating Supply Air Temperature (Default is 90°F).
IN0/11_ZN/EFdpt Status	R	zn_ef_dpt11_stat	AV	253	The current Zone or Exhaust Fan Duct Pressure Transducer Status (UI-11).
Local OAT/OARH Sensor Enabled	R/W	local_oa_sens_en	BV	1115	Read/write to Enable the Local OAT/OARH sensor.
LPS #1 Status	R	lps1_stat	BV	225	Low Pressure Switch #1 Status.
LPS #2 Status	R	lps2_stat	BV	228	Low Pressure Switch #2 Status.
LPS1 ALARM	R	lps1_alarm	BV	869	The current Low Pressure Switch #1 Alarm Status.
LPS1 STOP	R	lps1_stop_alarm	BV	870	The current Low Pressure Switch #1 Stop Alarm Status.
LPS2 ALARM	R	lps2_alarm	BV	883	The current Low Pressure Switch #2 Alarm Status.
LPS2 STOP	R	lps2_stop_alarm	BV	884	The current Low Pressure Switch #2 Stop Alarm Status.
LSAT ALARM	R	low_sat_alarm	BV	898	The current Low Supply Air Temperature Alarm Status.
MARH FAIL	R	marh_failure	BV	828	The current MARH Sensor Alarm Status.
MA-RH Status	R	marh_stat	AV	224	The Current Mixed Air Relative Humidity Status (MARH).
MAT FAIL	R	mat_failure	BV	827	The current MAT Sensor Alarm Status.
MAT Status	R	mat_stat	AV	223	The current Mixed Air Temperature (MAT).
Mixed Air Dew Point	R	ma_dewpoint	AV	264	The current Mixed Air Dew Point Status
Mixed Air Enthalpy	R	ma_enthalpy	AV	265	The current Mixed Air Enthalpy Status
Night Setback Mode ON	R	nsb_on	BV	219	This point displays the status of the Night Set Point Mode.
NOT ECON	R	not_econ_fdd	BV	961	The current FDD Alarm is not Economizing when it should.
OA AMS SP	R/W	oa_ams_sp	AV	306	The set point for Outdoor Air Monitoring Station (Default is 800 cfm)
OA Damper Enable	R	oada_en	BV	242	Outdoor Air Damper Enable Code Status

APPENDIX A – BAS COMMISSIONING (cont)

Table C – Mapping Points - Carrier 62W Rev. K - 100% Outdoor Air (cont)

DISPLAY NAME	READ/ WRITE	BACNET			DESCRIPTION
		REFERENCE NAME	TYPE	ID	
OADA ALARM	R	oada_alarm	BV	950	The current Outside Air Damper Actuator Alarm Status.
OADA HAND	R	oada_hand_alarm	BV	951	The current Outside Air Damper Actuator Hand Alarm Status.
OADA Minimum Position	R/W	oada_min_pos_cmd	AV	607	Read/write Outside Air Damper Minimum Position.
OADA PID Output Override	R/W	oada_pid_ovrd	AV	609	Read/write OADA PID Output for CAV (Percentage)
OADA PID Output Override Lock	R/W	oada_pid_ovrd_lock	BV	601	Read/write Outside Air Damper PID Output in Constant Air Volume (CAV) Status.
OADA Position	R	oada_pos	AV	204	The current Outside Air Damper Position Feedback.
OADA Status	R	oada_stat	BV	220	Outdoor Air Damper Actuator Auxiliary Status.
OARH FAIL	R	oarh_failure	BV	836	The current MAT Sensor Alarm Status.
OARH from BAS	R/W	bas_oarh	AV	1106	Read/write Outside Air Relative Humidity Supplied By BAS.
OA-RH Status	R	oarh_stat	AV	229	The Current Outdoor Air Relative Humidity Sensor Status (OARH).
OAT FAIL	R	oat_failure	BV	835	The current OAT Sensor Alarm Status.
OAT from BAS	R/W	bas_oat	AV	1104	Read/write Outside Air Temperature Supplied by BAS.
OAT Status	R	oat_stat	AV	227	The Current Outside Air Temperature Status (RAT).
Occupancy Control Options	R/W	occ_ctrl_opts	MSV	101	Read/write point will set the unoccupied/occupied control to local,BAS,24/7, CO ₂ mode.
Occupancy Status	R	occ_status	BV	105	This point gives you the unoccupied/occupied status of the unit.
Occupied Cooling Mode Low Limit	R/W	clg_llim	AV	319	The set point for Occupied Low Limit Cooling Temperature. (Default is 55°F)
OD Command	R	od_cmd	BV	1120	Outside Damper Start Command (BO-6).
Operating Condition	R	op_cond	AV	111	This point is a multistat and Table D must be used to cross reference the number to Condition.
Operating Mode	R	op_mode	AV	112	This point is a multistat and Table E must be used to cross reference the number to Operating Mode.
Optimal Start On	R	opt_start_on	BV	902	The current Optimal Start Status.
Outside Air Dew Point	R	oa_dewpoint	AV	266	The current Outside Air Dew Point Status
Outside Air Enthalpy	R	oa_enthalpy	AV	267	The current Outside Air Enthalpy Status
RADA NOT	R	rada_not_mod_fdd	BV	963	The current FDD Alarm the Dampers are Mechanically Disconnected.
RADA Position	R	rada_pos	AV	601	The current Return Air Damper Actuator Position.
RADA Status	R	rada_stat	AV	283	The current Return Air Damper Actuator Position Status
RARH FAIL	R	rarh_failure	BV	834	The current RARH Sensor Alarm Status.
RA-RH Status	R	rarh_stat	AV	226	The current Return Air Humidity (RARH).
RAT FAIL	R	rat_failure	BV	833	The current RAT Sensor Alarm Status.
RAT Status	R	rat_stat	AV	225	The current Return Air Temperature Sensor Status (RAT).
Return Air Damper Status	R	rada_cmd	BV	503	The current Return Air Damper Status
Return Air Dew Point	R	ra_dewpoint	AV	268	The current Return Air Dew Point Status
Return Air Enthalpy	R	ra_enthalpy	AV	269	The current Return Air Enthalpy Status
RH CMD	R	rh_cmd	BV	564	HGRH Start Command (BO-4).
RH in Cooling	R/W	rh_clg_mode	BV	561	Read/write point Enables Reheat in Cooling Mode.
RV CMD	R	rv_cmd	BV	550	The Reversing Valve Start Command (BO-5).
SARH FAIL	R	sarh_failure	BV	840	The current SARH Sensor Alarm Status.
SARH Status	R	sarh_stat	AV	237	The current Supply Air Relative Humidity Sensor Status (SARH).
SAT FAIL	R	sat_failure	BV	839	The current SAT Sensor Alarm status.
SAT Heat Fail SP	R/W	sat_heat_fail_sp	AV	361	The set point for Supply Air Temperature Heat Failure Alarm (Default is 50°F).
SAT High Limit SP	R/W	sat_high_limit_sp	AV	362	The set point High Supply Air Temperature alarm (Default is 120°F).
SAT Low Limit SP	R/W	sat_low_limit_sp	AV	808	The set point for Low Supply Air Temperature Alarm (Default is 40°F).
SAT Maximum Reset	R/W	sat_max_reset	AV	326	Read/write for the SAT Maximum for the ZAT/SAT reset Option (Default is 15).
SAT Ratio	R/W	sat_ratio	AV	325	Read/write for the SAT ratio for the ZAT/SAT reset Option (Default is 3).
SAT Status	R	sat_stat	AV	235	The current Supply Air Temperature (SAT).
SC ZAT DISA	R/W	sc_zat_disa	BV	1110	Read/write to Enable the ZAT control of the SC.
SD ALARM	R	sd_alarm	BV	896	The current Smoke Detector Alarm Status.
SD Status	R	sd_stat	BV	235	Smoke Detector Switch Status (N.C.).
SF ALARM	R	sf_alarm	BV	855	The current Supply Fan Alarm Status.
SF AMS SP	R/W	sf_ams_sp	AV	304	The set point for Supply Fan Air Monitoring Station (Default is 3900 cfm)
SF AMS Status	R	sf_ams_stat	AV	261	The current Supply Fan Air Monitoring Station Status
SF Command	R	sf_cmd	BV	241	Supply Fan Start Command (BO-1).
SF DPT SP	R/W	sf_dpt_sp	AV	301	The set point for Supply Fan Duct Pressure Transducer (Default 1 in. of H ₂ O).
SF DPT Status	R	sf_dpt_stat	AV	255	The current Supply Fan Duct Pressure Transducer Status (Default 5 in. of H ₂ O).

APPENDIX A – BAS COMMISSIONING (cont)

Table C – Mapping Points - Carrier 62W Rev. K - 100% Outdoor Air (cont)

DISPLAY NAME	READ/ WRITE	BACNET			DESCRIPTION
		REFERENCE NAME	TYPE	ID	
SF HAND	R	sf_hand_alarm	BV	856	The current Supply Fan Hand Alarm Status.
SF Mod. CLG Min. Output	R/W	sf_clg_min_out	AV	630	Read/write point for Supply Fan Modulation Minimum % for Cooling Operation (Default is 50%).
SF Mod. HP Min. Output	R/W	sf_hp_min_out	AV	629	Read/write point for Supply Fan Modulation Minimum % for Heat Pump Operation (Default is 85%).
SF Modulation	R	sfmod_pct	AV	282	The current Supply Fan Modulation Status (UO-1 Percentage).
SF Operation	R/W	sf_oper	MSV	931	Read/write point to set Occupied/unoccupied for the Supply Fan Operation (1=Continuous/Demand, 2=Con/Con, and 3= Dem/Dem).
SF PID Output Override	R/W	sf_pid_ovrd	AV	628	Read/write Supply Fan PID Output for CAV (Default is 90%).
SF PID Output Override Lock	R/W	sf_pid_ovrd_lock	BV	621	Read/write Supply Fan PID Output in Constant Air Volume (CAV) Status.
SF-APS or CS Status	R	sf_aps_stat	BV	223	Supply Fan Air Proven or Current Sensor Status.
SF Minimum Output	R	sf_min_out	AV	627	The set point for Supply Fan Minimum Output (50%).
SLT #1 Status	R	slt_stat	AV	250	The current Suction Line Temperature for circuit #1 (SLT1).
SLT #2 Status	R	slt2_stat	AV	251	The current Suction Line Temperature for circuit #2 (SLT2).
SLT FAIL	R	slt_failure	BV	845	The current SLT Sensor Alarm status.
SLT2 FAIL	R	slt2_failure	BV	846	The current SLT2 Sensor Alarm status.
Sub-Cooling Command	R	sc_cmd	BV	248	Sub-Cooling Start Command (BO-8)
Supply Air Dew Point	R	sa_dewpoint	AV	270	The current Supply Air Dew Point Status
Supply Air Enthalpy	R	sa_enthalpy	AV	271	The current Supply Air Enthalpy Status
Unit Stop	R	unit_stop	BV	819	The current Unit Stop Status.
Unoccupied Cooling Mode Low Limit	R/W	clg_llim_u	AV	320	The set point for Unoccupied Low Limit Cooling Temperature.
W1 Command	R	w1_cmd	BV	240	The Heating #1 Start Command (BO-5).
W1 Enable	R	w1_en	BV	578	The current Heating #1 Enable Status.
W2 Command	R	w2_cmd	BV	239	The Heating #2 Start Command (UO-6).
WExAT FAIL	R	wexat_failure	BV	837	The current WExAT Sensor Alarm Status.
WExAT Status	R	wexat_stat	AV	238	The current Wheel Exiting Air Temperature (WExAT).
WExRH FAIL	R	wexrh_failure	BV	838	The current WexRH Sensor Alarm Status.
WExRH Status	R	wexrh_stat	AV	239	The current Wheel Exiting Air Humidity (WExRH).
WFS ALARM	R	wfs_alarm	BV	829	The current Water Flow Switch Alarm Status.
WFS Status	R	wfs_stat	BV	230	Water Flow Switch Status in WSHF (N.O.).
ZAT FAIL	R	zat_failure	BV	852	The current ZAT Sensor Alarm Status.
ZAT From BAS	R/W	zat_bas	AV	208	The current Zone Air Temperature (ZAT) written to the controller by the BAS system.
ZAT Ratio	R/W	zat_ratio	AV	324	Read/write for the ZAT ratio for the ZAT/SAT reset Option (Default is 1).
ZAT Status	R	zat_stat	AV	209	The current Zone Air Temperature (ZAT) from the Zs sensor.
ZAT/SAT Set Point Reset Enable	R/W	rs_sat_en	BV	301	Read/writable point to enable ZAT/SAT Temperature Reset Option.
ZN DPT SP	R/W	zn_dpt_sp	AV	303	The set point for Zone Duct Pressure Transducer (Default is 0.020 in. of H ₂ O).
Zone Air Dew Point	R	za_dewpoint	AV	274	The current Zone Air Dew Point Status
Zone Air Enthalpy	R	za_enthalpy	AV	275	The current Zone Air Enthalpy Status
Zone Set Points	R/W	clg_zat_sp_o	AV	200	The set point for Zone Temperature Set Point for occupied cooling resides in the Set Point Microblock (Default is 74°F).
Zone Set Points	R/W	htg_zat_sp_o	AV	201	The set point for Zone Temperature Set Point for occupied heating resides in the Set Point Microblock (Default is 68°F).
Zone Set Points	R/W	clg_zat_sp_u	AV	202	The set point for Zone Temperature Set Point for unoccupied cooling resides in the Set Point Microblock (Default is 80°F).
Zone Set Points	R/W	htg_zat_sp_u	AV	203	The Zone Temperature Set Point for unoccupied heating resides in the Set Point Microblock (Default is 60).
ZRH FAIL	R	zrh_failure	BV	853	The current ZRH Sensor Alarm Status.
Z-RH From BAS	R/W	zrh_bas	AV	211	The current Zone Air Humidity (Z-RH) written to the controller by the BAS system.
Z-RH Status	R	zrh_stat	AV	212	The current Zone Air Humidity (Z-RH) from the ZS sensor.

APPENDIX A — BAS COMMISSIONING (cont)

LEGEND FOR PAGES 86-90

APS	— Air Pressure Switch	MDC	— Modulating Discharge Controller
BAS	— Building Automation System	MDV	— Modulating Discharge Valve
CCS	— Compressor Current Switch	MRC	— Modulating Reheat Controller
CFI	— Clogged Filter Indicator	MRV	— Modulating Reheat Valve
CM1A	— Compressor #1	NC	— Normally Closed Contact
CC1A	— Compressor #1 Contactor Coil	NO	— Normally Opened Contact
CC1A-A1	— Compressor #1 Auxiliary Contact	OA	— Outside Air; prior to any conditioning
CFM	— Cubic Feet per Minute (volumetric flow rate)	OD	— Outside Air Damper
CPM	— Compressor Protection Module	OA-RH	— Outside Air Relative Humidity (real), measured before air enters the ERV, if existing
CM2A	— Compressor #2	OAT	— Outside Air Temperature (real), measured before air enters the ERV, if existing
CC2A	— Compressor #2 Contactor Coil	OEM	— Automated Logic Incorporated, a division of Carrier
CC2A-A1	— Compressor #2 Auxiliary Contact	OFM1	— Outdoor Fan #1 Motor
DCM	— Digital Compressor Module	OF1C	— Outdoor Fan #1 Contactor Coil
DPT	— Differential Pressure Transmitter	OF1-VFD	— Outdoor Fan #1 Variable Frequency Drive
DOAU	— Dedicated Outdoor Air Unit	OFM2	— Outdoor Fan #2 Motor
DOM	— Delay-On-Make	OF2C	— Outdoor Fan #2 Contactor Coil
EC-RH	— Entering Coil Relative Humidity, measured before entering the DX coil and after the ERV	OF2-VFD	— Outdoor Fan #2 Variable Frequency Drive
ECAT	— Entering Coil Air Temperature, measured before entering the DX coil and after the ERV	RHR	— Reheat Relay
ERV	— Energy Recovery Ventilator	RHS	— Reheat Valve Solenoid
EMR	— Energy Management Relay; normally closed contact	RTHO	— Room Temperature Heating Override
EF	— Exhaust Fan	RTRHO	— Room Temperature Reheat Override
EF-APS	— Exhaust Fan Air Pressure Switch	SD	— Smoke Detector; normally closed contact
EF-DPT	— Differential Pressure Transmitter	SF	— Supply Fan
EF-VFD	— Exhaust Fan Variable Frequency Drive	SF-APS	— Supply Fan Air Pressure Switch
FPM	— Feet per Minutes (velocity)	SF-DPT	— Differential Pressure Transmitter
FSC	— Fan Speed Control	SF-VFD	— Supply Fan Variable Frequency Drive
HAR	— Heating Analog Relay	SLT	— Suction Line Temperature, attached to the suction line near the suction header of the DX coil
HARM	— Heating Analog Relay Module	VFD	— Variable Frequency Drive
HGRH	— Hot Gas Reheat	WM	— Wheel Motor
HPS	— High Pressure Switch	WMC	— Wheel Motor Contactor
HP1	— High Pressure Switch #1	WM-VFD	— Wheel Motor Variable Frequency Drive
HP2	— High Pressure Switch #2	ZAT	— Zone Air Temperature
LA	— Low Ambient Pressure Sensor	Z-RH	— Zone Relative Humidity
LAT	— Leaving Air Temperature		
LP1	— Low Pressure Switch #1		
LP2	— Low Pressure Switch #2		

APPENDIX B – OPERATING MODES AND CONDITIONS

Table D – Operating Conditions

VALUE	DISPLAY	VALUE	DISPLAY
0	SCHEDULE	27	C1 HAND
1	OA DAMPER	28	C2 ALARM
2	FAN ONLY	29	C2 STOP
3	ECONOMIZER	30	HPS2 ALARM
4	COOLING	31	HPS2 STOP
5	CLG and REHEAT	32	LPS2 ALARM
6	DEHUMID	33	LPS2 STOP
7	HEATING	34	FP2 ALARM
8	HEAT PUMP	35	FP2 STOP
9	AUX HEAT	36	C2 HAND
10	EMER HEAT	37	HEAT FAIL
11	DEFROST ON	38	HIGH SAT
12	PURGE #1	39	WFS ALARM
13	PURGE#2	40	FZT ALARM
14	FDD ALARM	41	RUN TIME
15	SF FAIL	42	SP OVERLAP
16	SF HAND	43	SENSOR FAIL
17	EF FAIL	44	CLGD FLTR
18	EF HAND	45	COS ALARM
19	C1 ALARM	46	HIGH CO2
20	C1 STOP	47	HIGH SFDPT
21	HPS1 ALARM	48	SD STOP
22	APS2 STOP	49	SAT FAIL
23	LPS1 ALARM	50	LOW SAT
24	LPS1 STOP	51	DISABLED
25	FP1 ALARM	52	ENERGY MGT
26	FP1 STOP	53	EMERSHTDN

Table E – Operating Modes

VALUE	DISPLAY
0	UNOCCUPIED
1	NIGHT STBK
2	OPT START
3	OCCUPIED
4	TESTING
5	ALARM
6	SHUTDOWN

APPENDIX C — EQUIPMENT QUICK START-UP GUIDANCE

Unit Preparation

Check that unit has been installed in accordance with the installation instructions, applicable codes and recommended service clearances.

Verify Unit Installation

Verify the unit is installed using the correct power and heat source as per the model tag (Fig. C).

- Verify installation voltage
- Verify installation MCA and MOCP
- Verify installation heat source (gas, electric, hot water, steam)
- Verify installation heat fuel (natural gas or propane)

Unit Set Up

Make sure that all hoods have been installed, shipping brackets removed, and that the final filters, ERV filter (if equipped), and air intake screen filters are properly installed. Verify curbs and ductwork have been installed and are free from obstruction.

Condensate Traps

Units will have a drain pan under the evaporator and gas heat units will have an additional condensate drain in the gas heat section. Make sure both traps are installed properly and drain properly. Gas heat can generate condensation during low ambient conditions, so trap may need to be freeze protected.

Internal Wiring

Ensure that all electrical connections in the control box are tightened as required. Verify that all sensors are reading properly (see Calibration screen).

Field Installed Sensors

Verify that the SAT/RH sensor has been installed, wired, and configured for voltage output. Verify that the DPT sensors (if equipped) have been installed, wired and configured for voltage output. Verify that the ZAT sensor (if required) is installed. Sensors may have configurable ranges and outputs. Verify sensor range and output match wiring diagram and control program.

Crankcase Heaters

All units are equipped with crankcase heaters. Verify that they are operational. The heaters must operate 24 hours before starting up the unit for cooling operation. The crankcase heaters will be on whenever the unit has power and the compressors are off.

Supply Fan

Make sure that fans rotate in the proper direction and are free from obstruction. Make sure the spring isolation (if equipped) allows for fan movement. Verify design airflow from submittal. For pressure control, verify the DPT has been installed and verify the DPT set point. For AMS control, verify the airflow CFM set point.

Exhaust Fan (If Equipped)

Make sure that fans rotate in the proper direction and are free from obstruction. Make sure the spring isolation (if equipped) allows for fan movement. Verify design airflow from submittal. For pressure control, verify the DPT has been installed and verify the DPT set point. For AMS control, verify the airflow CFM set point.

Energy Conservation Wheel (If Equipped)

Verify the ECW wheel rotates freely and in the correct direction. Verify ECW belt tension. Check to make sure the ECW filters are installed and clean.

Condenser

Make sure that the condenser fans rotate in the proper direction. Check fans for obstructions. Verify that the condenser coil is free from damage.

Unit Clearance

Verify unit clearance from other objects as per installation instructions.

Gas Heating (If Equipped)

Check gas piping for leaks, verify installation as per local code. Verify gas pressure as supply tap. Verify gas shut off valve. Verify manifold pressure. Verify gas condensate trap has been installed.

Hot Water Heating (If Equipped)

Units with hot water ship with a hot water coil. Piping, piping penetrations, and control valve and actuator are field provided. Actuator control can come from unit controller. HW heat can operate during low ambient conditions, so ensure antifreeze is used in cold climates.

CONTROL

Verify that the unit and the controller have power and that the controller power is enabled. Verify that a control interface (Equipment Touch, Equipment Touch app, Field Assistant) is available and installed.

SET POINTS

The unit has multiple methods of control and multiple set points. The unit will ship factory configured for a basic control method (OAT vs SAT control) and default set points. Confirm with the customer if adjustments to the control and set points are needed.

OCCUPANCY

Verify how the unit occupancy will be controlled (BAS, 24/7, or local schedule). Verify that the occupancy control has been provided or unit schedule has been added.

NETWORKING

Verify if the unit will be stand alone or networked with a BAS. If the unit will be networked, verify that the appropriate wiring and networking equipment (router) has been installed. Also verify that the unit has been configured for networked control.

Equipment Touch Start-up Tips

Use the following instructions to start up the unit using the Equipment Touch or the Equipment Touch App.

BASICS/SET UP

Each 62W controller will come pre-configured from the factory to match the options of the unit. Some set points and settings may need to be modified in the field by the installing contractor or Carrier Commercial Service, to meet the requirements of the application.

The recommended interface for start-up of the 62W unit is the Carrier Equipment Touch (E-Touch) display or the Equipment Touch App. The E-Touch display is wired to the 62W controller at the Service port. An external 24VDC is needed to power the E-Touch. Please refer to the Equipment Touch Installation and Set Up Guide for more details.

The E-Touch App can be used on Android phones or tablets and requires the USB Link Cable, which connects to the 62W unit at the Rnet Access Port and the USB port of the Android device. Please refer to the Equipment Touch App User Guide for further details.

Throughout start-up, various passwords will be needed to set up E-Touch.

- 1111 is the Admin password and should allow full equipment start-up.
- 1602: Carrier default BACnet device instance number

APPENDIX C — EQUIPMENT QUICK START-UP GUIDANCE (cont)

FAN CONTROL

The supply and exhaust fans for the 62W units can be controlled by one of three methods, constant speed, pressure control, or air flow control. The fan control method is determined based on the unit configuration. It may be necessary to force the fan speed to full in order to perform start-up on a 62W unit or when air balancing a 62W unit.

AIR BALANCING (FORCING FAN SPEEDS)

The manual override function can be used to set a fixed fan speed for start-up or air balancing. The manual override can be set by going into “Set Up” (see Fig. D and E), “Man Ovr”, enabling the SF or EF manual override and setting the fan speed (%). Please note, when the manual override is enabled, the unit will continue to operate at the set fan speed, whenever the unit is in occupied mode. This can be used to lock in constant speed units to a set speed. **For duct pressure control or airflow control units, be sure to disable the manual override after start-up is completed.**

For duct pressure control or airflow monitor control units, it may be necessary to set a minimum supply fan or exhaust fan speed during balancing. A minimum fan speed can be set by going into “Set Up”, “Tech Set Up” (see Fig. D-F), and then adjusting the SF or EF minimum fan speed set points. The supply or exhaust fan speed will not drop below the set minimum fan speed during operation.

START-UP CHECKLIST: OPERATION MODES

Prior to performing start-up, verify that the unit operation is enabled on the Tech Set Up screen (Home →Set Up→Tech Set Up). This setting can be set back to disabled to prevent unit operation.

When going through the unit start-up checklist, it will be necessary to test the unit in cooling/dehumidification and heating modes to obtain the start-up information.

Revision K units are equipped with a test mode that can be used during unit start up. See the Test Mode section on page 32. Figure C shows a Revision K nameplate.

If the unit is not equipped with the Test Mode feature, use the following instructions below.

The unit can be forced into heating/cooling/dehumidification mode by tricking the unit to read a different outdoor air temperature (OAT) by using the sensor offset function. From the Home screen, go to “Set Up”, “Calibration” (see Fig. D, E, and G) to access the sensor offset screen. See Fig. F.

To test a unit in cooling/dehumidification mode, the OAT sensor reading must be higher than the cooling OAT enable set point (70°F, default). For example, if the OAT sensor is reading 65°F with no offset, the offset can be set to +15°F so that the sensor reads 80°F and enable cooling mode. Upon changing the sensor offset, wait ~5 minutes before checking the cooling status. Once operation is confirmed, **be sure to set the sensor offset back to 0 or the desired value.**

For units with multiple stages of cooling, it may be necessary to apply an offset to either the DX LAT or the SAT set point to force on additional stages of compression. For units in cooling mode, the unit SAT reading must be 3°F or greater than the cooling SAT set point for the second stage to be enabled. For units in dehumidification mode, the DX LAT reading must be 3°F or greater than the DX LAT set point for the second stage to be enabled.

For units with variable capacity compressors, the manual override function can be used to force the compressor to full capacity. The manual override function can be accessed by going to “Set Up”, “Man Ovr”, enabling the manual override for the compressor and setting the required compressor capacity (%). **Be sure to disable the manual override to restore normal compressor control.**

To put the unit into heating mode, the OAT sensor reading must be below the heating OAT enable set point (55°F, default). For example, if the OAT sensor is reading 65°F with no offset, the OAT sensor can be offset by -35°F to read 30°F and enable heating mode. Upon changing the sensor offset, wait ~5 minutes before checking the heating status. Once operation is confirmed, **be sure to set the sensor offset back to 0 or the desired value.**

For units with modulating gas or electric heat, the manual override function can be used to force the heat to full capacity. The manual override function can be accessed by going to “Set Up”, “Man Ovr”, enabling the manual override for the heat source and setting the required capacity (%). **Be sure to disable the manual override to restore normal heat control.**

APPENDIX C – EQUIPMENT QUICK START-UP GUIDANCE (cont)

SET TIME AND DATE

The 62W controller has a built in time clock that must be set for proper operation. The Time and Date screen can be accessed from the BAS Set Up screen (*Home*→*Set Up*→*Misc Settings* →*BAS Set Up*→*Set Time and Date*).



Fig. D – Home Screen

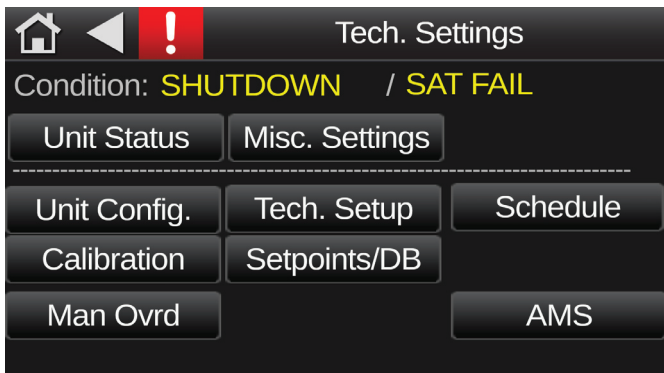

Fig. E – Home Screen→Set Up

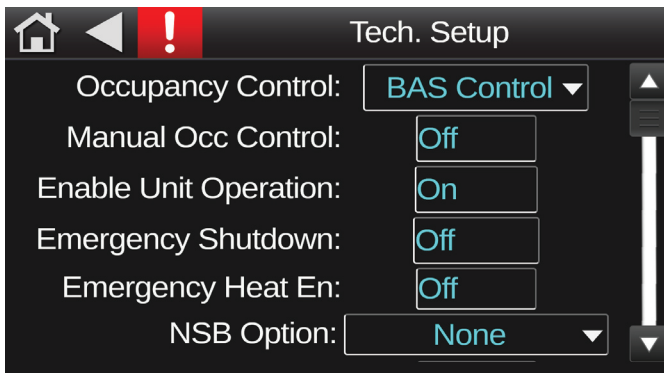

Fig. F – Home Screen→Setup→Tech. Setup



Fig. G – Home Screen→Setup→Calibration

OCCUPANCY CONTROL

The 62W unit can be configured for multiple occupancy control methods, including BAS control, 24/7 occupancy, or local schedule. See Fig. F. Set the appropriate occupancy control method and ensure occupancy control devices (BAS) have been provided.

SCHEDULES

If a local schedule is being used, a schedule must be set in the unit controller. The Schedule screen can be accessed through the Controls page. Access to the schedules may require the user password “1111”. To add a schedule, click on the “Add Schedule” button (see Fig. H) and follow the steps below.

1. Create a Schedule Name.
2. Choose: On Schedule (Occupied) or Off Schedule (Unoccupied)
3. Choose Schedule Priority Type: Normal or Override
4. Choose Schedule Type: Dated, Weekly, or Continuous
5. Determine Start and End Time and Date of Schedule
6. Save your schedule. System will upload to OEM controller box.

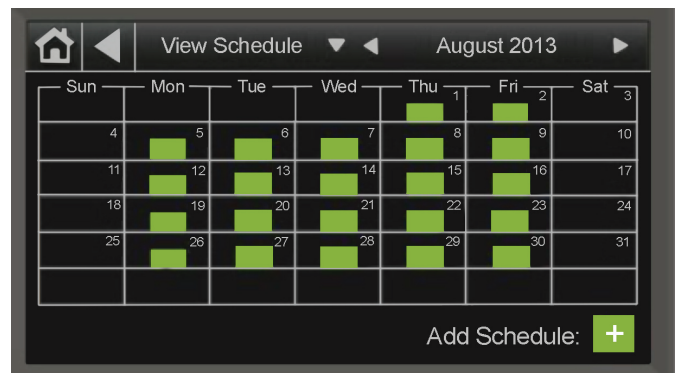

Fig. H – Home Screen→Setup→Schedules

Application Limitations

Verify the following application limitations are not being exceeded. If an application requires exceeding a limitation, please contact service or application engineering.

ELECTRIC HEAT

Minimum 50 CFM airflow per every kW of heat across the electric heating coil.

GAS HEAT

Standard Maximum Temperature rise is 80°F/100°F for horizontal/vertical supply. Maximum High Temperature rise is 130°F/160°F for horizontal/vertical supply and requires an XL cabinet.

EVAPORATOR

Maximum face velocity of 550 FPM and minimum face velocity of 150 FPM.

ENTERING AIR TEMPERATURE

Maximum Cooling EAT: 115°F; Minimum Cooling EAT: 35°F; Minimum Auxiliary Heating EAT: -20°F; Minimum Heat Pump Heating EAT: 35°F.

ERV

Maximum pressure drop of 1.75 in. wg.

APPENDIX D – CONTROL NAVIGATION DIAGRAM

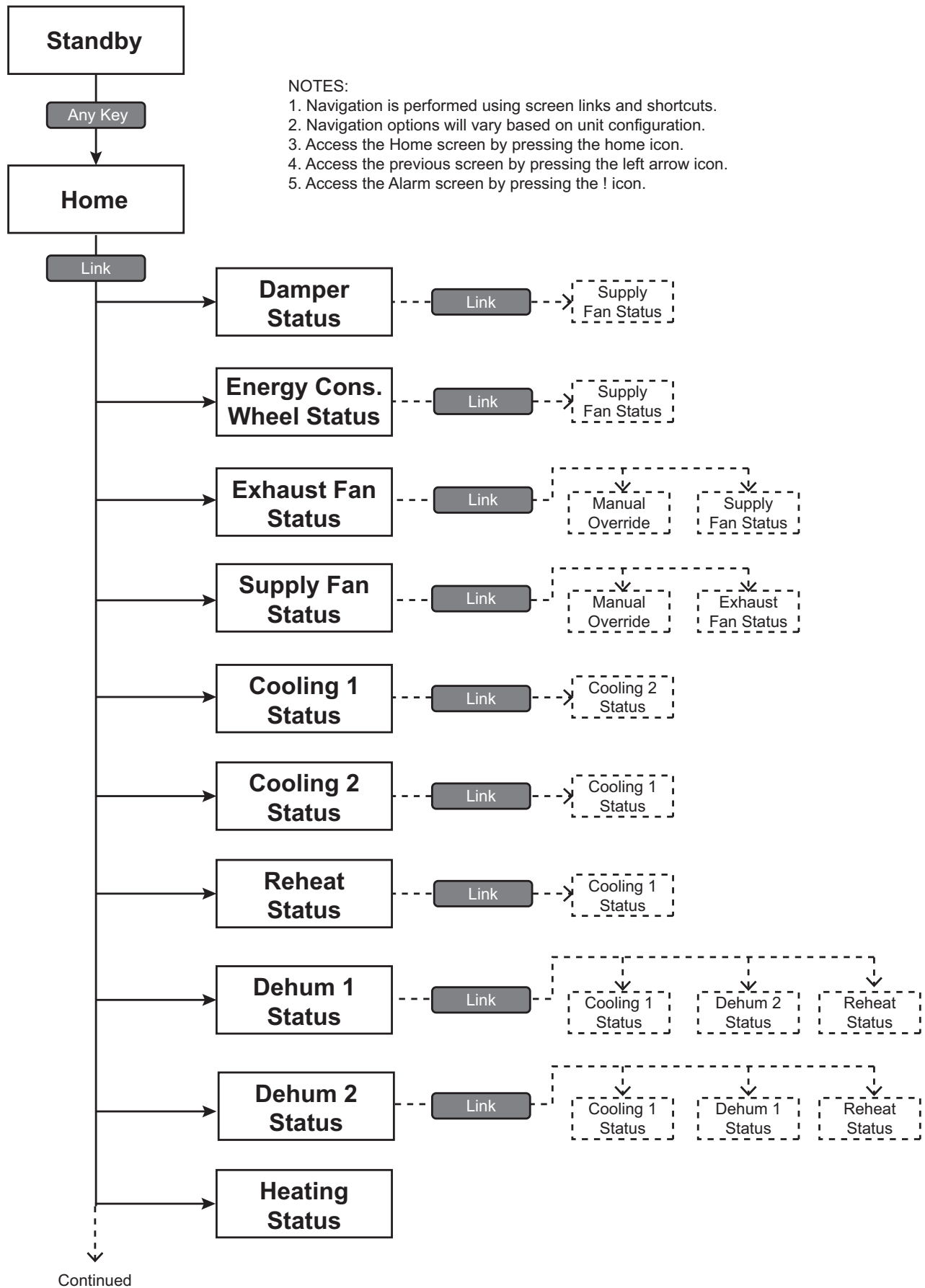

Fig. I – 62W Control Navigation

APPENDIX D – CONTROL NAVIGATION DIAGRAM (cont)

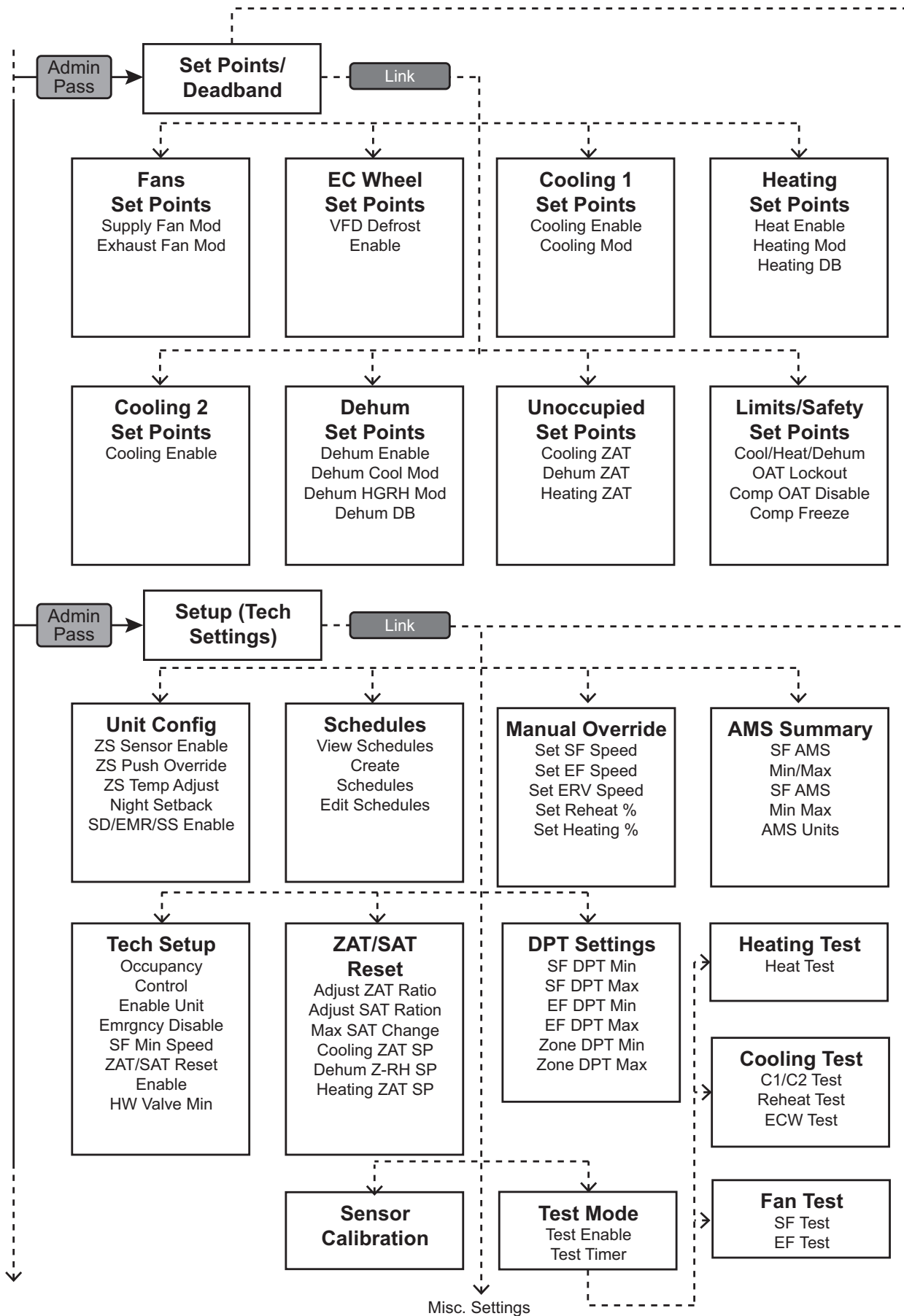

Fig. I – 62W Control Navigation (cont)

APPENDIX D – CONTROL NAVIGATION DIAGRAM (cont)

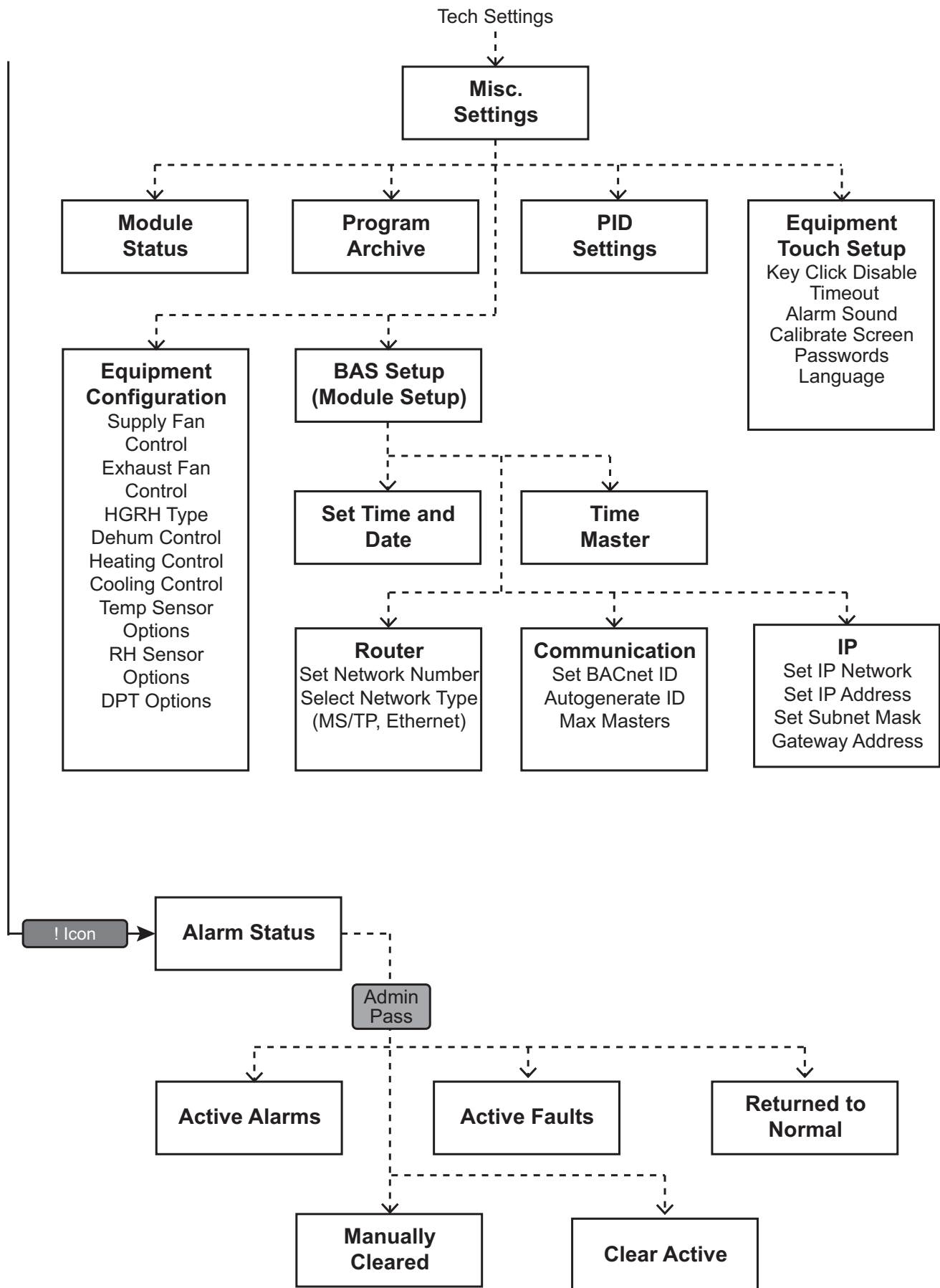

Fig. I – 62W Control Navigation (cont)

APPENDIX E – AIR BALANCE INSTRUCTIONS

(An Equipment Touch Device or Equipment Touch App will be required for air balance.)

INSTRUCTIONS

Check the box to verify the activity has been completed. If the activity does not apply, write N/A in the box. The admin password (1111) will be required for control configuration.

SUBMITTAL REVIEW

1. Review the unit submittal (see Fig. J.) and record the following information for the supply fan and exhaust fan (if equipped):
 - Design airflow, design external static (duct static, not including unit options)
 - Fan RPM
 - Motor BHP, Motor FLA
2. Review the factory installed options from the unit model number (last 2 digits) to confirm the supply fan and exhaust fan (if equipped) control method (see Table 1 and Table 3). Available options include:
 - Constant speed (no airflow option).
 - Pressure control (duct pressure for supply fan [SF-DPT], space pressure for exhaust fan [Zn-DPT], if equipped).
 - Airflow monitor control for supply fan and exhaust fan (if equipped).
 - Blanket quote ETO for supply fan space pressure control is also available and would show on the unit submittal.

NOTE: the supply and exhaust fans cannot be controlled to the same sensor.

3. Review fan control methodology with customer to confirm operation.

AIR BALANCE PRE-CHECK

- All fire dampers and VAV dampers are verified to be open at the maximum position.
- Verify all filters are installed and are clean.
- For units with pressure control (duct only or duct and space), review the DPT range settings.
- Verify that the unit has power and that the unit controller has power and is on.
- Verify that the Equipment Touch has power and is communicating with the unit controller.
- For units with pressure control, navigate to the DPT summary screen (*Home*→*Setup*→*DPT*) and verify that the SF-DPT (supply duct) and Zn-DPT (building exhaust) min and max settings match the DPT range.

AIR BALANCE SETUP

1. Using the Equipment Touch, navigate to the Test screen (*Home*→*Setup*→*Test*) and enable test mode by changing Run Test to “On”.
2. For units with ECW, navigate to the Cooling Test screen (*Home*→*Setup*→*Test*→*Cooling*) and enable the ECW by changing Run ECW to “On”.
3. Navigate to the Fans Test screen (*Home*→*Setup*→*Test*→*Fans*) and enable the supply fan by changing Run SF Test to “On” and enable the exhaust fan (if equipped) by changing the Run EF Test to “On”.

Cooling/Dehumidification Performance

Cooling Airflow:.....	1500	CFM	
Ambient Air Temp:.....	95.0	F	
Ent. Coil Air Dry Bulb:.....	95.0	F	
Ent. Coil Air Wet Bulb:.....	78.0	F	
Evap Lvg. Air Dry Bulb:.....	53.6	F	
Evap Lvg. Air Wet Bulb:.....	53.2	F	
Lvg. Air Dry Bulb (Max. Reheat):.....	99.8	F	
Lvg. Air Wet Bulb (Max. Reheat):.....	69.6	F	
Gross Cooling Capacity:.....	128.80	MBH	
Gross Sensible Clg. Cap:.....	68.40	MBH	
Compressor Power:.....	8.78	KW	

Supply Fan Performance:

Ext. Static Pressure:.....	1.00	in wg	
Total Static Pressure:.....	1.34	in wg	
Supply Fan Type:.....	Backward Inclined Supply Fan		
Supply Fan Size:.....	12" Backward Inclined Supply Fan, Direct Drive		
Supply Fan Motor Type:.....	ODP Supply Fan Motor		
Supply Fan Motor Size:.....	1 HP Supply Fan Motor		
Supply Fan RPM:.....	1893		
Supply Fan BHP:.....	0.50	BHP	

Electrical Data

Unit Voltage:.....	230-3-60		
Unit Amps - FLA:.....	44.82		
Min. Circuit Ampacity - MCA:.....	49.3		
Maximum Fuse Size - MFS:.....	60		
Compressor RLA (ea.):.....	17.9		
Compressor LRA (ea.):.....	110		
Supply Fan FLA:.....	3.02		
Condenser FLA (ea.):.....	3		

Fig. J – Unit Submittal Example

APPENDIX E – AIR BALANCE INSTRUCTIONS (cont)

CONSTANT SPEED BALANCING

1. Navigate to the Manual Override screen (**Home**→**Setup**→**Man Ovr**) and set the Supply Fan and Exhaust Fan (if equipped) output to “On”.
2. Change the percent value to change the fan speed (0-100%) to achieve the design airflow.

NOTE: allow time between changing the fan speeds for the system to balance out.

3. Once the proper fan speeds have been identified to achieve the design airflow, leave the manual override “On” and the percent set to the needed speed.

NOTE: Whenever the unit fan(s) are commanded on, they will run in the override mode at the set percent speeds. The fan(s) will turn off when commanded off by the controller (unoccupied mode).

VARIABLE SPEED BALANCING - PRESSURE CONTROL

1. Navigate to the Manual Override screen (**Home**→**Setup**→**Man Ovr**) and set the Supply Fan and Exhaust Fan (if equipped) output to “On”.
2. Change the percent value to change the fan speed (0-100%) to achieve the design airflow.

NOTE: allow time between changing the fan speeds for the system to balance out.

3. Once the proper fan speeds have been identified to achieve the design airflow, navigate to the Supply Fan Status screen (**Home**→**Sup Fan**) and record the supply fan pressure reading (SF-DPT).
4. For units with exhaust fan, navigate to the Exhaust Fan Status screen (**Home**→**Ex Fan**) and record the building pressure reading (Zn-DPT).

5. Navigate to the Fan Set Points screen (**Home**→**Stp/DB**→**Fans**) and set the following parameters to match the recorded values.

- Supply Fan Mod: DPT (for supply fan duct pressure control) or ZNDPT (for supply fan space pressure control ETP).
- Bldg Static Press ZNDPT (for exhaust fan space pressure control, if equipped).

Navigate to the Manual Override screen (**Home**→**Setup**→**Man Ovr**) and set the Supply Fan and Exhaust Fan (if equipped) output to “Off”. The fans will now operate to the DPT set points.

6. For duct pressure control applications, it's also recommended to set a minimum supply fan speed of no lower than 50%. If the minimum airflow requirement is known, use the Manual Override (**Home**→**Setup**→**Man Ovr**) function to find the required minimum fan speed. Once identified, navigate to the Tech Settings screen (**Home**→**Setup Tech.**→**Setup**) screen and set the SF Minimum Setting to the identified minimum speed. Remove the Manual Override function to restore normal operation.

VARIABLE SPEED BALANCING - AIRFLOW MONITOR CONTROL

Navigate to the Fan Set Points screen (**Home**→**Stp/DB**→**Fans**) and set the following parameters to match design airflow:

- Supply Fan Mod: CFM
- Exhaust Fan Mod: CFM

The fans will now operate to the set CFM when enabled.

AIR BALANCE CHECKOUT

Verify Test Mode has been disabled (**Home**→**Setup**→**Test**) by changing Run Test to “Off”.

PRE-START-UP CHECKLIST

Pre-Start-Up Checklist must be completed by installing contractor and submitted to the Carrier start-up team or the start-up contractor.

PROJECT INFORMATION

Project Name _____
Address _____
City _____
State/Province _____ Zip Code _____
Installer _____
Contact Name _____
Contact Phone _____
Contact Email _____

UNIT INFORMATION

Model Number _____
Serial Number _____
ERV Model Number (if equipped): _____
ERV Serial Number (if equipped): _____

INSTRUCTIONS

Check the box to verify the activity has been completed. If the activity does not apply, write N/A in the box. Refer to the unit submittal for airflow, static, and leaving air temperature conditions.

Installation

- All packing materials have been removed from the unit.
- The unit is free of damage. If damage exists, contact your local Carrier representative.
- The unit has been installed in accordance with required service clearances and required access.
- The unit is within level tolerances to promote proper condensate drainage.
- All required field installed unit components (hoods, filters, sensors, etc.) have been installed.
- Space cooling and heating units exist to control space conditions (temperature and humidity).

Electrical

- The unit power feed is installed.
- The unit voltage and frequency have been verified to match the incoming power and phasing.
- The power feed phasing is correct.
- The power feed meets the MCA requirements as indicated on the unit label.
- The fuses or circuit breaker safeties meet the MOCP requirements as indicated on the unit label.
- All electrical connections and terminals are tight; all terminals are free from corrosion.

Supply Fan

- The supply fan(s) are free from obstruction and rotate properly.
- The design supply fan airflow is _____ CFM.
- The supply fan will be controlled by (circle one): constant speed / duct pressure / space pressure / airflow station.
- For duct pressure control, the design duct static pressure is _____ in. wg
- For space pressure control, the design building static pressure is _____ in. wg
- The outdoor air screens are installed and are clean.
- The evaporator filters are installed and are clean.

Filter Status Switch (in filter section)

- Verify that the adjustment screw on the front of the switch is fully clockwise (do not strip threads).

Cooling

- The air-cooled condenser coil(s) is clean and free from obstructions and defects.
- The evaporator coils are clean and free from obstructions and defects.
- The refrigeration circuit is free from leaks.
- The condensate drain trap has been installed per installation instructions and is draining freely.
- The crank case heaters verified to be operational and will operate 24 hours prior to cooling start-up.

Manufacturer reserves the right to discontinue, or change at any time, specifications or designs without notice and without incurring obligations.

- Cooling mode will be enabled by (circle one): OAE / OAT / OAT and OADP / OAT and OAE / OAT vs. SAT
- The cooling circuit 1 should be enabled above: _____
- The design cooling coil leaving air temperature is: _____ (default is 55°F).
- The design cooling supply air temperature (SAT) is: _____ (default is 70°F).
- For dual circuit units, the cooling circuit 2 should be enabled above: _____
- Dehumidification (dehum) mode will be enabled by (circle one): OADP vs SADP / OAE / SARH
- Dehum mode will be enabled above: _____
- The dehum design supply air temperature is: _____ (default is 70°F)

Gas Heat (if equipped)

- The gas piping has been connected per the installation instructions and has no leaks.
- Gas shutoff valves and gas regulator have been installed and have been verified to operate properly.
- The inlet gas pressure and gas quality are enough for proper unit operation.
- The gas heat condensate trap has been installed per the installation instructions and freeze protected.
- Heating will be enabled by (circle one): OAT / OAT vs SAT
- Heating shall be enabled below: _____
- The design heating supply air temperature is: _____ (default is 70°F)

Hot Water Heat (if equipped)

- The hot water piping has been installed and is free from leaks.
- The hot water loop is protected against freezing using antifreeze. Verify concentration and protection.
- The hot water control valve has been installed and is wired to the unit controller (UO-6).
- Heating will be enabled by (circle one): OAT / OAT vs SAT
- Heating shall be enabled below: _____
- The design heating supply air temperature is: _____ (default is 70°F)
- The minimum hot water valve position to protect against freezing should be: _____%

Field Provided Heat (if equipped)

- The field provide heat control has been installed and is wired to the unit controller (UO-6).
- Select the heating type (circle one): gas / electric / hot water / steam
- Select the heating stages (circle one): 1 / 2 / 3 / 4 / modulating
- Heating will be enabled by (circle one): OAT / OAT vs SAT
- The heating enable set point shall be: _____
- The heating SAT set point shall be: _____ (default is 70°F)

Exhaust Fan (if equipped)

- The exhaust fan(s) are free from obstruction and rotate properly.
- The design exhaust fan airflow is _____ CFM
- The exhaust fan will be controlled by (circle one): constant speed / space pressure / airflow station
- For space pressure control, the design building static pressure is _____ in. wg.

Energy Conservation Wheel (if equipped)

- The ECW belt is installed with the proper tension and the wheel can rotate properly.
- The ECW outdoor air and exhaust air filters have been installed and are clean
- For units with VFD defrost, the WExAT shall be _____ (default is 25°F)
- All pre-start-up procedures listed in the installation instructions have been completed.

Occupancy

- The occupancy will be controlled by (circle one): BAS / unit schedule / 24/7 occupied
- For start/stop switch control, a normally open relay has been installed and wired back to the unit (UI-12)
- For local unit schedule, the following schedule type is needed (circle one): weekly / continuous
- For schedule 1, the unit shall be occupied on (circle any): Mon / Tues / Weds / Thur / Fri / Sat / Sun
- For schedule 1, the unit shall be occupied from: _____ AM/PM to _____ AM/PM
- For schedule 2, the unit shall be occupied on (circle any): Mon / Tues / Weds / Thur / Fri / Sat / Sun
- For schedule 2, the unit shall be occupied from: _____ AM/PM to _____ AM/PM

CUT ALONG DOTTED LINE

CUT ALONG DOTTED LINE

Shutdown Control

- The following EMR functionality is needed (circle one): EMSD (disable unit) / EMR (force unocc mode)
- For emergency shutdown or energy management control, a normally closed relay has been installed and wired back to the unit (UI-15)
- For field provided smoke detector, a normally closed smoke detector has been installed and wired back to the unit (UI-16)

Sensors

- The supply air temperature and relative humidity (SAT/RH) sensor has been installed in the supply ductwork a minimum of 10 feet away from the heat source and has been wired back to the unit controller (UI-3 for temperature and UI-4 for humidity)
- For units with the pressure control option, the supply duct pressure sensor has been installed and wired back to the unit controller (UI-10). The sensor has been zeroed out prior to operation.
- For units with exhaust fan and the pressure control option, the space pressure sensor has been installed and wired back to the unit controller (UI-11). The sensor has been zeroed out prior to operation.
- The sensor calibration screen has been reviewed and all sensors are verified to have correct readings. If any sensor reads -60°F (open) or 296°F (short), check the sensor and sensor wiring. If the problem persists, contact your Carrier sales representative.

SAT Reset (if equipped)

- Supply air temperature (SAT) reset based on zone air temperature (ZAT) is required.
- A zone air temperature sensor (ZAT) sensor has been installed and wired to the controller (Rnet port).
- Select the ZAT sensor operation (circle all that apply): temp / occ override / set point adjust
- For set point adjust from the ZAT sensor, the max adjustment amount is \pm _____ $^{\circ}\text{F}$ (default is 5°F).
- For units with multiple ZAT sensors, the ZAT sensors have been individually addressed.
- The design occupied cooling zone air temperature is _____ (default is 70°F).
- The design occupied heating zone air temperature is _____ (default is 70°F).

Night Setback (NSB, if equipped with ETO return air damper)

- NSB operation with return air based on zone air temperature (ZAT) is required.
- Select the NSB modes as required (circle all that apply): unocc cooling / unocc heating / unocc dehum
- A zone air temperature sensor (ZAT) sensor has been installed and wired to the controller (Rnet port).
- Select the ZAT sensor operation (circle all that apply): temp / humidity / occ override / set point adjust
- For set point adjust from the ZAT sensor, the max adjustment amount is \pm _____ $^{\circ}\text{F}$ (default is 5°F).
- For units with multiple ZAT sensors, the ZAT sensors have been individually addressed.
- The design unoccupied cooling zone air temperature is _____ (default is 80°F).
- The design unoccupied heating zone air temperature is _____ (default is 60°F).
- The design unoccupied zone relative humidity is _____ (default is 60%).
- Select the supply fan operation during unoccupied mode (circle one): continuous / on demand

Building Automation System (BAS, if equipped)

See Appendix A for communication set up and wiring information.

- The following network protocol will be used (circle one): BACnet MS/TP
- For BACnet communication wiring has been connected to the unit (Port 1 or Port 2A).
- The controller dip switches, rotary dials, and jumpers have been properly configured (address, baud rate, network type, etc.).
- The network router number shall be: _____
- The controller's address (BACnet ID) shall be: _____
- The controller is properly communicating with the network.
- The controller is not communicating with the network and has been disconnected.

Control Interface

- The Equipment Touch control interface has been installed, powered, wired to the Rnet port on the unit controller, and verified to be communicating with the unit controller.
- The Equipment Touch will not be installed, and the start-up team has been notified that a separate control interface (Equipment Touch, Equipment Touch App, or Field Assistant) will be required for start-up.

CONTROL CONFIGURATION

An Equipment Touch, Equipment Touch App, or Field Assistant will be required for control configuration. The unit control configuration must be completed by installing contractor or start-up contractor prior to equipment start-up. If completed by the installing contractor, provide to the Carrier start-up team.

PROJECT INFORMATION

Project Name _____
Address _____
City _____
State/Province _____ Zip Code _____

Installer _____
Contact Name _____
Contact Phone _____
Contact Email _____

UNIT INFORMATION

Model Number _____

Serial Number _____

INSTRUCTIONS

Check the box to verify the activity has been completed. If the activity does not apply, write N/A in the box. The admin password (1111) will be required for control configuration.

Record the control and set point configurations on the included tables

UNIT SETUP

Equipment Configuration (*Home*→*Setup*→*Misc Settings*→*Config*)

- Verify that the SF Option matches the supply fan operating mode from the pre-start-up checklist.
- Verify that the EF Option matches the exhaust fan operating mode from the pre-start-up checklist.
- Verify that the HGRH Option matches the unit model number.
- Configure the Dehum Option to match the dehum enabled by condition from the pre-start-up checklist.
- Verify the Heating Option matches the unit model number or configure to match the field provided heat from the pre-start-up checklist.
- Configure the Cooling Enabled By to match the cooling enabled by condition from the pre-start-up checklist.
- Configure the Heating Enabled By to match the heating enabled by condition from the pre-start-up checklist.
- Verify the Temp Option #1 configuration matches the unit configuration (OAT, SAT for units without ECW, ECAT, OAT, SAT for units with ECW).
- Verify the Temp Option #2 configuration matches the unit configuration (None for units without ECW, RAT, WExAT for units with ECW).
- Verify the Humidity Option #1 configuration matches the unit configuration (OARH, SARH for units without ECW, ECRH, SARH for units with ECW).
- Verify the Humidity Option #2 configuration matches the unit configuration (None for units without ECW, RAT, WExAT for units with ECW).
- Verify the Air Pressure Options configuration matches the unit configuration (None for units without pressure control option, SF-DPT for units with pressure control option and supply fan only, SF-DPT and ZN-DPT for units with pressure control option and supply and exhaust fan). ZN-DPT for supply fan only pressure control available as ETO for field enabled.

Tech Settings (*Home*→*Setup*→*Tech. Setup*)

- Configure the Occupancy Control to match the occupancy control from the pre-start-up checklist.
- Verify Manual Occ Control is set to "OFF" (unless needed for temporary operation).
- Verify Enable Unit Operation is set to "OFF" (until equipment start up has been completed).
- Verify Emergency Shutdown is set to "OFF" .
- Verify Emergency Heat Enable is set to "OFF" .
- Set the SF Minimum Setting to 50% (unless value has been set by air balance contractor).
- Configure ZAT/SAT Reset (if required) based on the pre-start-up checklist.
- Configure HW Valve Minimum % (if required) based on the pre-start-up checklist.
- Configure SF Occ/Unocc based on unoccupied supply fan operation on the pre-start-up checklist.

CUT ALONG DOTTED LINE

CUT ALONG DOTTED LINE

Unit Control Configuration (Home→Setup→Unit Config)

- Configured the Zone Sensor Option, Push-Button Override, and Zone Set Point Adjust based on the ZAT sensor operation from the SAT Reset or NSB sections of the pre-start-up checklist (if needed).
- Adjust the Set Point Adjust ± set point based on the max set point adjustment from the SAT Reset or NSB sections of the pre-start-up checklist (if required).
- Verify the NSB Option is set to “None” for units without the night setback ETO or indicate the type of operation that’s needed from the NSB operation section of the pre-start-up checklist (if required).
- Verify the Misc Options A is configured for clogged filter indicator (CFI) and condensate overflow switch (COS) for units without a factory or field installed smoke detector (SD) or configured for CFI, COS, SD for units with a factory or field installed smoke detector.
- Verify the Misc Options B is configured for either “None”, “EMSD” (emergency shutdown), or “EMR” (energy management relay) as indicated in the occupancy or shutdown control sections of the pre-start-up checklist.

SAT Reset (if equipped) (Home→Setup→SAT Reset)

- Adjust the ZAT ratio as needed (default is 1°F). Increase the ratio reduce the reset amount.
- Adjust the SAT ratio as needed (default is 3°F). Increase the ratio to increase the reset amount.
- Adjust the Max Change as needed (default is 15°F).
- Adjust the Clg ZAT SP to match the design occupied cooling zone air temperature from the SAT reset section of the pre-start-up checklist.
- Adjust the Htg ZAT SP to match the design occupied heating zone air temperature from the SAT reset section of the pre-start-up checklist.

DPT Summary (if equipped) (Home→Setup→DPT)

- Review the range for the duct pressure transmitter (if exists). Enter the range minimum for the SF-DPT Minimum and the range maximum for the SF-DPT Maximum.
- Review the range for the space pressure transmitter (if exists). Enter the range minimum for the Zn-DPT Minimum and the range maximum for the Zn-DPT Maximum.

Manual Override (Home→Setup→Man Ovr)

- Verify all manual override outputs are set to “Off” (unless supply and exhaust fan values have been set by air balance contractor).

Calibration (Home→Setup→Calibration)

- Verify all offsets are set to “0.00” (unless adjustments have been made by a professional calibrator).

Set Time and Date (Home→Setup→Misc. Settings→BAS Setup→ Set Time and Date)

- The current time and date has been set in the controller.

Equipment Configuration	
PARAMETER	CONFIGURATION
SF Option	
EF Option	
HGRH Option	
Dehum Option	
Heating Option	
Cooling Enabled By	
Heating Enabled By	
Temp Option #1	
Temp Option #2	
Humidity Option #1	
Humidity Option #2	
Air Pressure Option	

Tech Settings	
PARAMETER	CONFIGURATION
Occupancy Control	
Manual Occ Control	
Enable Operation	
Emergency Shutdown	
Emergency Heat	
Supply Fan Min %	
Supply Fan Min HP	
ZAT Reset	
Ht Water Vlv Min %	
SF Occ/Unocc	

Unit Control Configuration	
PARAMETER	CONFIGURATION
Zone Sensor Type	
ZS Button Override	
ZS Set Point Adjust	
ZS Adjust +/-	
Night Setback	
Misc. Options A	
Misc. Options B	

Manual Override		
PARAMETER	OUTPUT	PERCENT
Supply Fan		
Exhaust Fan		
EC Wheel		
Reheat		
Heating		

SAT Reset	
PARAMETER	CONFIGURATION
ZAT Ratio	
SAT Ratio	
Max Change	
Cooling ZAT	
Heating ZAT	

DPT Summary	
PARAMETER	CONFIGURATION
SF DPT Min	
SF DPT Max	
Building DPT Min	
Building DPT Max	

SET POINTS

Fans Set Points

- Set the Bldg Static Press set point (if equipped) to match the design building static pressure from the pre-start-up checklist.
- Set the Supply Fan Mod DPT set point (if equipped) to match the design duct static pressure from the pre-start-up checklist.
- Set the Supply Fan Mod AMS set point (if equipped) to match the design supply fan airflow from the pre-start-up checklist.
- Set the Exhaust Fan Mod AMS set point (if equipped) to match the design exhaust fan airflow from the pre-start-up checklist.

ECW Set Points (if equipped)

- Set the ECW defrost set point to match the WExAT from the pre-start-up checklist.

Cooling 1 Set Points

- Set the Clg #1 enable set point to match the cooling 1 enable above point from the pre-start-up checklist.
- Set the Clg #1 Mod DXLAT set point to match the design cooling coil leaving air temperature from the pre-start-up checklist.
- Set the Cooling SAT set point to match the design cooling supply air temp from the pre-start-up checklist

Cooling 2 Set Points (if equipped)

- Set the Clg #2 enable set point to match the cooling 2 enable above point from the pre-start-up checklist.

Dehum Set Points

- Set the Dehum enable set point to match the dehum enable above point from the pre-start-up checklist.
- Set the Dehum SAT set point to the dehum design supply air temperature from the pre-start-up checklist.

Heating Set Points (if equipped)

- Set the heating enable set point to match the dehum enable above point from the pre-start-up checklist.
- Set the heating SAT set point to the heating design supply air temp from the pre-start-up checklist.

Limits/Safety SP

- Adjust the cooling, dehumidification low limits and the heating high limits as necessary.
- Adjust the compressor 1 and 2 disable set points as needed.

Unoccupied Set Points (if equipped with NSB ETO only)

- Adjust the cooling and heating ZAT set points and dehum ZRH set points as indicated on the pre-start-up checklist.

CUT ALONG DOTTED LINE

CUT ALONG DOTTED LINE

PARAMETER	SENSOR	SET POINT	UNITS
Fans SP			
Building Static Press			in. wg
Supply Fan Mod	AMS / DPT		cfm/in. wg
Exhaust Fan Mod	AMS / DPT		cfm/in. wg
ECW SP			
ECW Defrost	WE _x AT		°F
Cooling 1 (Clg1) SP			
Clg #1 Enable	OA/ECAT / OA/ECE / LAT		
Clg #1 Mod	DX LAT		°F
Cooling SAT	SAT		°F
Cooling ZAT	ZAT		°F
Cooling 2 (Clg2) SP			
Clg #2 Enable	OA/ECAT / OA/ECE / LAT		
Dehumidify (DH) SP			
Dehumidify Enable	OA/ECDP / SADP		
Dehumidify SAT	SAT		°F
Reheat Upper SAT DB	SAT		°F
Reheat Lower SAT DB	SAT		°F
Heating (Htg1) SP			
Htg #1 En	OA/ECAT		°F
Heating SAT	SAT		°F
Heating Upper SAT DB	SAT		°F
Heating Lower SAT DB	SAT		°F
Heating ZAT	ZAT		°F
Heat Pump 1 (HP1) SP			
HP #1 Enable	OA/ECAT		°F
HP #1 Enable	SAT		°F
Heating SAT	SAT		°F
Heating Upper SAT DB	SAT		°F
Heating Lower SAT DB	ZAT		°F
Heating ZAT	OA/ECAT		°F
Heat Pump 2 (HP2) SP			
HP #2 Enable	OA/ECAT		°F
HP #2 Enable	SAT		°F
Heating SAT	SAT		°F
Heating Upper SAT DB	SAT		°F
Heating Lower SAT DB	ZAT		°F
Heating ZAT	OA/ECAT		°F
Unoccupied			
Cooling SAT	SAT		°F
Cooling ZAT	ZAT		°F
Dehumidify	ZARH		%RH
Heating SAT	SAT		°F
Heating ZAT	ZAT		°F

UNIT SCHEDULE (if required)

Local Schedule (Home→Setup→Schedule)

Configure the local weekly or continuous occupied schedule per the pre-start-up checklist.

WEEKLY SCHEDULE														
Weekday	MON		TUE		WED		THU		FRI		SAT		SUN	
Occ/Unocc	On	Off	On	Off	On	Off	On	Off	On	Off	On	Off	On	Off
Period 1														
Period 2														
Period 3														
Period 4														

Dated Schedule		Start Date						End Date						
Weekday	MON		TUE		WED		THU		FRI		SAT		SUN	
Occ/Unocc	On	Off	On	Off	On	Off	On	Off	On	Off	On	Off	On	Off
Period 1														
Period 2														
Period 3														
Period 4														

Dated Schedule		Start Date						End Date						
Weekday	MON		TUE		WED		THU		FRI		SAT		SUN	
Occ/Unocc	On	Off	On	Off	On	Off	On	Off	On	Off	On	Off	On	Off
Period 1														
Period 2														
Period 3														
Period 4														

BAS COMMUNICATION (if required)

Communication (if required for BAS) (Home→Setup→Misc. Settings→BAS Setup→Communication)

Verify the BACnet ID matches the BACnet ID provided from the pre-start-up checklist.

Router (if required for BAS) (Home→Setup→Misc. Settings→BAS Setup→Router)

Enter the BACnet network number next to the box for the selected communication protocol.

Verify that there is a 0 next to the unused network protocols.

COMMUNICATION	
Parameter	Configuration
BACnet Device Instance	
Autogenerate ID	
Max Masters	
Max Info Frames	

ROUTER	
Parameter	Configuration
MS/TP	
Ethernet	

PROGRAM ARCHIVE

After the control program has been configured and all set points set up, it's recommended to save the control program within the controller.

Archive (Home→Setup→Misc. Settings→Archive)

The control program archive has been saved as confirmed by the current archive date.

CUT ALONG DOTTED LINE

START-UP CHECKLIST

Copy to be provided to the customer and sales office.

NOTE: To avoid injury to personnel and damage to equipment or property when completing the procedures listed in this start-up checklist, use good judgment, follow safe practices, and adhere to the safety considerations/information as outlined in preceding sections of this Controls, Operation, Start-Up and Troubleshooting guide.

Prior to performing start-up, the crank case heaters must operate for 24 hours.

Cooling start-up can only be performed when the outdoor air temperature is above 55°F.

An Equipment Touch, Equipment Touch App, or Field Assistant is required to perform start-up.

PROJECT INFORMATION

Project Name _____

Installer _____

Address _____

Contact Name _____

City _____

Contact Phone _____

State/Province _____ Zip Code _____

Contact Email _____

UNIT INFORMATION

Model Number _____

Serial Number _____

INSTRUCTIONS

Check the box to verify the activity is completed. If the activity does not apply, write N/A in the box.

PRE-START-UP CHECKLIST

Installation

- All packing materials have been removed from the unit.
- The unit is free of damage. If damage exists, contact your local Carrier representative.
- The unit has been installed in accordance with required service clearances and required access.
- The unit is within level tolerances to promote proper condensate drainage.
- All required field installed unit components (hoods, filters, sensors, etc.) have been installed.
- Space cooling and heating units exist to control space conditions (temperature and humidity).

Electrical

- The unit power feed is installed.
- The unit voltage and frequency have been verified to match the incoming power and phasing.
- The power feed phasing is correct.
- The power feed meets the MCA requirements as indicated on the unit label.
- The fuses or circuit breaker safeties meet the MOCP requirements as indicated on the unit label.
- All electrical connections and terminals are tight; all terminals are free from corrosion.
- Measure the voltage between each power feed and record the measured voltage on the start-up log.
- The power voltage is within 10% of nameplate voltage and the voltage imbalance is less than $\pm 2\%$.

Supply Fan

- The outdoor air damper is closed.
- The supply fan(s) are free from obstruction and rotate properly.
- The outdoor air screens are installed and are clean.
- The evaporator filters are installed and are clean.
- All fire dampers or VAV dampers are open to allow free airflow.

Cooling

- The air-cooled condenser coil(s) is clean and free from obstructions and defects.
- The evaporator coils are clean and free from obstructions and defects.
- The refrigeration circuit is free from leaks and contains a refrigerant charge.
- The scroll compressors are rotating in the correct direction and the compressor oil level is acceptable.
- The condenser fan(s) rotation direction is correct, and rotation is not obstructed.
- The condensate drain trap has been installed per installation instructions and is draining freely.

- The crank case heaters are verified to be operational and will operate 24 hours prior to cooling start-up (if equipped).

Gas Heat (if equipped)

- The gas piping has been connected per the installation instructions and has no leaks.
- Gas shutoff valves and gas regulator have been installed and have been verified to operate properly.
- The inlet gas pressure and gas quality are enough for proper unit operation.
- The gas heat condensate trap has been installed per the installation instructions and freeze protected.

Hot Water Heat (if equipped)

- The hot water piping has been installed and is free from leaks.
- The hot water control valve has been installed and is wired to the unit controller (UO-6).
- The hot water loop has been protected against freezing using antifreeze.
- Verify the antifreeze concentration and low ambient freeze protection limits.

Field Provided Heat (if equipped)

- The hot water control valve has been installed and is wired to the unit controller (UO-6).

Exhaust Fan (if equipped)

- The barometric outdoor air damper is closed and freely moves.
- The exhaust fan(s) are free from obstruction and rotate properly.
- All fire dampers or VAV dampers are open to allow free airflow.

Energy Conservation Wheel (if equipped)

- The ECW belt has been verified per guidelines listed in the installation instructions.
- The ECW outdoor air and exhaust air filters have been installed and are clean.
- The ECW bypass damper (if equipped) is open when the wheel is off.

Filter Status Switch (in filter section)

- Verify that the adjustment screw on the front of the switch is fully clockwise (do not strip threads).

Sensors

- The supply air temperature and relative humidity (SAT/RH) sensor has been installed in the supply ductwork a minimum of 10 feet away from the heat source and has been wired back to the unit controller (UI-3 for temperature and UI-4 for relative humidity).
- For units with the pressure control option, the supply duct pressure sensor has been installed and wired back to the unit controller (UI-10). The sensor has been zeroed out prior to operation.
- For units with exhaust fan and the pressure control option, the space pressure sensor has been installed and wired back to the unit controller (UI-11). The sensor has been zeroed out prior to operation.
- The sensor calibration screen has been reviewed and all sensors are verified to have correct readings. If any sensor reads -60°F (open) or 296°F (short), check the sensor and sensor wiring.

Controls

- The controller power switch is on and the controller battery is installed.
- A control interface is available (Equipment Touch, Equipment Touch App, or Field Assistant) and functional.

START-UP

Functional Check

Use the test mode function (**Home**→**Setup**→**Test**) to verify the function and record the operation of unit components. The admin password (1111) will be required for the run test. To enable Test Mode, change the Run Test parameter from “Off” to “On”. Use the test mode screens to run individual components tests by turning the run function from “Off” to “On”. See the Test Mode Section for more details.

For modulating components, use the Manual Override function (**Home**→**Setup**→**Misc. Settings**→**Man Ovr**) to force the component to 100% operation by setting the output to “On” and setting the percent to “100”). See the Manual Override section for more details.

Outdoor Air Damper

- The outdoor air damper opens to 100% position when commanded

Supply Fan

- The supply fan is rotating in the correct direction.
- The supply fan is operating without vibration or other issue.
- Force the supply fan to 100% operation or the maximum air balanced speed and record the amp draw on the start-up log.

Filter Status (in filter section)

- With the fan operating at high speed, turn the adjustment screw counterclockwise until the flag drops.

CUT ALONG DOTTED LINE

CUT ALONG DOTTED LINE

- Turn the adjustment screw 1-1/2 turns clockwise and reset the flag.

Exhaust Fan (if equipped)

- The exhaust fan is rotating in the correct direction.
- The exhaust fan is operating without vibration or other issue.
- The barometric exhaust damper is open and moves freely.
- Force the exhaust fan to 100% operation and record the amp draw on the start-up log.

Cooling

NOTE: Cooling and dehumidification can only be performed when the outdoor air temperature is above 55°F.

- Verify all condenser fans are rotating and rotation direction is correct.
- Verify all condenser fans are rotating without vibration or other issue.
- Verify the compressor(s) are operating and compressor rotation is correct.
- Verify the compressor(s) are operating without vibration or other issue. NOTE: Size 03-018 units have a lead circuit digital compressor that will unload/load during operation, leading to some vibration and noise.
- Verify the outdoor air temperature on the start-up log, if above 55°F proceed with cooling start-up.
- (62W only) verify entering water flow and entering water temperature above 55°F.
- With the compressor(s) operating, subcooling reheat operating (if equipped), and hot gas reheat (HGRH) operating at 100%, record the following information in the start-up log:
 - Compressor amp draw (all compressor)
 - Evaporator coil leaving air temperature (DXLAT)
 - Unit supply air temperature (SAT)
 - (62W only) entering condenser water temperature (EWT) and condenser water flow rate
- With the compressor(s) operating, subcooling reheat operating (if equipped), and hot gas reheat (HGRH) **disabled**, record the following information in the start-up log:
 - Suction line temperature (all circuits)
 - Suction line pressure (all circuits)
 - Discharge line temperature (all circuits)
 - Discharge line pressure (all circuits)
 - Record the compressor oil level (where available)

Energy Recovery Wheel (if equipped)

- The exhaust fan is rotating without vibration or other issue.
- The ECW bypass damper (if equipped) is closed when the ECW is rotating.
- Force the ECW to 100% operation and record the amp draw on the start-up log.
- Test the ECW Defrost for 10% speed and verify if the wheel slows down.
- All post-start-up procedures listed in the Installation Instructions have been completed.

Gas Heat (if equipped)

- Verify inducer fan operation.
- Verify spark and ignition.
- With the supply fan operation at 100% speed or the balanced speed and the gas heat operating at high fire (100% capacity), record the following information in the start-up log:
 - Outdoor air temperature (OAT)
 - Unit supply air temperature (SAT)
 - Inlet pressure (all furnaces)
 - Manifold pressure (all furnaces)
 - Flue gas CO and CO₂ levels (all furnaces)
 - Inducer draft fan pressure (all furnaces)
- With the supply fan operation at 100% speed or the balanced speed and the gas heat operating at low fire (50% capacity for 2 stage units, 25% capacity for 4 stage units, 20% capacity for 5:1 modulating units, and 10% capacity for 10:1 modulating units), record the following information in the start-up log:
 - Outdoor air temperature (OAT)
 - Unit supply air temperature (SAT)
 - Inlet pressure (single furnace)
 - Manifold pressure (single furnace)
 - Flue gas CO and CO₂ levels (single furnace)
 - Inducer draft fan pressure (single furnace)

Electric Heat (if equipped)

- With the supply fan operation at 100% speed or the balanced speed and the electric heater operating at 100% capacity, record the following information in the start-up log:
 - Outdoor air temperature (OAT)
 - Unit supply air temperature (SAT)
 - Heater amp draw
- With the supply fan operation at 100% speed or the balanced speed and the electric heater operating at 50% capacity, record the following information in the start-up log:
 - Outdoor air temperature (OAT)
 - Unit supply air temperature (SAT)
 - Heater amp draw

Hot Water Heat (if equipped)

- With the supply fan operation at 100% speed or the balanced speed and the electric heater operating at 50% capacity, record the following information in the start-up log:
 - Outdoor air temperature (OAT)
 - Unit supply air temperature (SAT)
 - Heater amp draw

Field Installed Heat (if equipped)

- With the supply fan operation at 100% speed or the balanced speed and the electric heater operating at 100% capacity, record the following information in the start-up log:
 - Heater operation and signal response
- With the supply fan operation at 100% speed or the balanced speed and the electric heater operating at 50% capacity, record the following information in the start-up log:
 - Heater operation and signal response

START-UP CHECKOUT

- Verify Test Mode has been disabled (**Home**→**Setup**→**Test**) by changing Run Test to “Off”.
- Verify all manual overrides have been turned off, unless set by air balance (**Home**→**Setup**→**Misc. Settings**→**Man Ovr**).
- Verify all sensor offsets have been turned off, unless set by calibration (**Home**→**Setup**→**Calibration**).
- Verify that the current time and date has been set in the controller (**Home**→**Setup**→**Misc. Settings**→**BAS**). **Setup**→**Set Time and Date**).
- Verify emergency shutdown is set to “Off” (**Home**→**Setup**→**Tech. Setup**).
- Verify manual occupancy control is set to “Off” (**Home**→**Setup**→**Tech. Setup**).
- Verify configured occupancy control is set to the last known setting (**Home**→**Setup**→**Tech. Setup**).
- Set Enable Unit Operation to “On” (**Home**→**Setup**→**Tech. Setup**).
- Verify no alarms are displayed (**Home**→**Alarms**).

The unit should now restore normal operation.

CUT ALONG DOTTED LINE

CUT ALONG DOTTED LINE

START-UP LOG

Prior to performing start-up, the crank case heaters must operate for 24 hours.

Power Supply

L1-L2 Voltage _____ L1-L3 Voltage _____ L2-L3 Voltage _____

Average Voltage _____ (L1-L2 + L1-L3 + L2-L3)/3

Voltage Tolerance _____ (Average Voltage-Nameplate Voltage)/Nameplate Voltage

Voltage Imbalance _____ (Maximum Deviation Voltage/Average Voltage) x 100

The Maximum Deviation Voltage is the voltage that is furthest away from the Average Voltage.

Supply Fan, Exhaust Fan, and ECW

NOTE: Motor amp readings should be taken at full airflow (100%) and full ECW speed (100%).

Supply Fan Amps Motor 1 _____ Motor 2 _____

Exhaust Fan Amps Motor 1 _____ Motor 2 _____

Energy Wheel Motor Amps Motor 1 _____

Supply Fan Airflow (if known) _____ CFM Static _____ in. wg

Exhaust Fan Airflow (if known) _____ CFM Static _____ in. wg

Cooling and Dehumidification

NOTE: Cooling start-up can only occur when the outdoor air temperature is above 55°F.

Outdoor Air Temperature (OAT) _____ °F DB _____ °F WB

Evaporator Coil LAT (DXLAT) _____ °F DB

Unit Supply Air Temperature (DXLAT) _____ °F DB _____ °F WB

Condenser Entering Water Temp (62W Only) _____ °F

Entering Water Flow Rate (62W Only) _____ GPM

Circuit 1 Compressor A Amps _____ Amps

Circuit 1 Compressor B Amps _____ Amps

Circuit 2 Compressor A Amps _____ Amps

Circuit 2 Compressor B Amps _____ Amps

NOTE: DX temperatures and pressures should be measured with subcooling on (if equipped) and HGRH (reheat) off.

Suction Line Temperature Circuit No. 1 _____ °F Circuit No. 2 _____ °F

Suction Line Pressure Circuit No. 1 _____ Circuit No. 2 _____

Discharge Line Temperature Circuit No. 1 _____ °F Circuit No. 2 _____ °F

Discharge Line Pressure Circuit No. 1 _____ Circuit No. 2 _____

Compressor Oil Level

Fill in the circle to indicate sight glass oil level.

Circuit 1 Compressor A

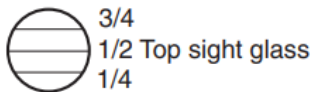

Circuit 1 Compressor B



Circuit 2 Compressor A

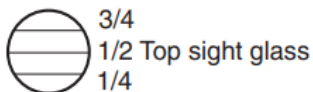

Circuit 2 Compressor B



Gas Heat (if equipped)

Outdoor Air Temperature (OAT) _____ °F DB

Unit Supply Air Temperature (SAT) _____ °F DB at High Fire (100% capacity and airflow)

Furnace 1

Inlet Pressure _____ in. wg

Manifold Pressure Low Fire _____ in. wg High Fire _____ in. wg

CO₂ In Flue Gas Low Fire _____ % High Fire _____ %

CO In Flue Gas Low Fire _____ Ppm High Fire _____ Ppm

Draft Fan Pressure Low Fire _____ in. wg High Fire _____ in. wg

Furnace 2 (XL units only)

Inlet Pressure _____ in. wg

Manifold Pressure Low Fire _____ in. wg High Fire _____ in. wg

CO₂ In Flue Gas Low Fire _____ % High Fire _____ %

CO In Flue Gas Low Fire _____ Ppm High Fire _____ Ppm

Draft Fan Pressure Low Fire _____ in. wg High Fire _____ in. wg

Electric Heat (if equipped)

Outdoor Air Temperature (OAT) _____ °F DB

Unit Supply Air Temperature (SAT) _____ °F DB at 100% capacity and airflow

Electric Heater Amp Draw _____ Amps at 100% capacity and airflow

Unit Supply Air Temperature (SAT) _____ °F DB at 50% capacity and 100% airflow

Electric Heater Amp Draw _____ Amps at 50% capacity and 100% airflow

Hot Water Heat (if equipped)

Hot Water Fluid Type _____ Concentration _____

Outdoor Air Temperature (OAT) _____ °F DB

Unit Supply Air Temperature (SAT) _____ °F DB at 100% capacity and airflow

Hot Water Entering Water Temp _____ °F

Hot Water Leaving Water Temp _____ °F at 100% capacity and airflow

Hot Water Fluid Flow Rate _____ GPM at 100% capacity

Unit Supply Air Temperature (SAT) _____ °F DB at 50% capacity and 100% airflow

Hot Water Entering Water Temp _____ °F

Hot Water Leaving Water Temp _____ °F at 50% capacity and 100% airflow

Hot Water Fluid Flow Rate _____ GPM at 50% capacity

CUT ALONG DOTTED LINE

CUT ALONG DOTTED LINE