

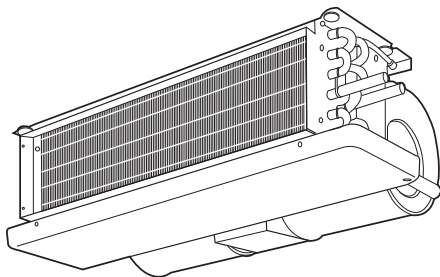

# Product Data

## 42C,D,S,V Series Fan Coil Air Conditioners

150 to 2000 cfm



**42CA HORIZONTAL**

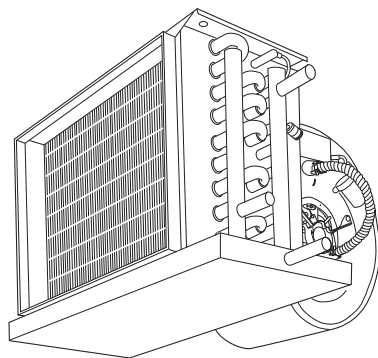

**42DA DUCTED**

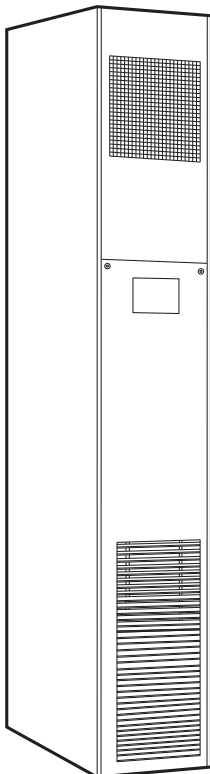

**42SH STACK**

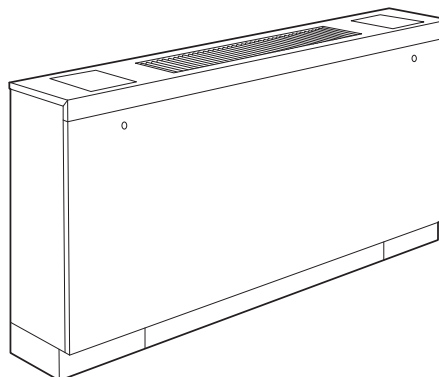

**42VBC VERTICAL**

Carrier's 42C,D,S,V Series fan coil units offer:

- Design flexibility, occupying minimum space
- Easy, low-cost installation
- Permanent split capacitor or electronically commutated motors deliver peak operating efficiency
- High performance, low cost
- Greater zone comfort control

### Features/Benefits

**Carrier's extensive range of superior fan-coil units combine design flexibility with easy, low-cost installation.**

#### Versatility

With Carrier's 42 Series fan coils, you can select from 4 horizontal, 6 vertical, 5 ducted or 5 stacked models; furred-in or cabinet style, slant top or low silhouette, in 150 through 2000 cfm capacities. Coils are available with up to 5 rows (depending on model), to satisfy a variety of application requirements. The units are ideal for installation in motels, apartments, and other multi-room buildings. Many optional control packages are available to facilitate the following modes of operation: 2-pipe heating and cooling, 2-pipe heating and cooling with auxiliary electric heat, 2-pipe cooling with total electric heat, and 4-pipe heating and cooling. The control package offering includes 24-v or line voltage thermostats and BACnet\* communicating controls.

Casings and frame are fabricated from tough, heavy gage galvanized steel. Custom decorative colors allow the unit to blend with any interior design.

# Features/Benefits (cont)



## Low-cost installation and operation

Each unit is designed to occupy a minimum space. No complex system controls are required for Carrier fan coil units. Piping, drain, and wiring connections are readily accessible and mounting holes and slots are pre-drilled to save installation time and field labor expense.

## 42 Series quality reduces service and maintenance expenses

All coils are factory leak tested at 300 psig air pressure with coil

submerged in water. Condensate drain pans are available in stainless steel or heavy gage galvanized steel constructions, along with optional condensate overflow switches complying to the latest building codes. A variety of insulation types are available for energy savings, sound absorption and indoor air quality (IAQ) preservation.

## Efficient operation

Blower wheels are centrifugal-type, forward curved, double width, and double inlet sized for maximum efficiency.

## Quiet, dependable performance

All units are built to operate unobtrusively with quiet motors and fans. In addition, 1/2-in. thick sound-absorbing, insulation is used to line the cabinet.

## 42C Series horizontal, 42V Series vertical units

Carrier room fan coil units are constructed with insulation that absorbs operating sound. The rugged construction reduces vibration during operation.

Economical, three-speed fans deliver just the right amount of conditioned air for your comfort needs at any load, and each unit can be shut off when not in use. Optional electronically commutated motors deliver peak operating efficiency. By choosing Carrier units, you can match your application with a wide range of custom-designed options and accessories, including electric heat. Filters are cleanable or throwaway type.

Carrier room fan-coil units provide year-round comfort.

# Table of contents

	Page
Features/Benefits . . . . .	1-7
Options . . . . .	8-12
Controls . . . . .	13-16
Selection Procedure . . . . .	17
Application Data . . . . .	17-33
<b>42C</b>	
Model Number Nomenclature . . . . .	34
AHRI Capacity Ratings . . . . .	35
Physical Data . . . . .	36
Base Unit Dimensions . . . . .	37-52
Accessory Dimensions . . . . .	53
Performance Data . . . . .	54-57
Electrical Data . . . . .	58, 59
<b>42V</b>	
Model Number Nomenclature . . . . .	60
AHRI Capacity Ratings . . . . .	61
Physical Data . . . . .	62
Base Unit Dimensions . . . . .	63-75
Accessory Dimensions . . . . .	76, 77
Electrical Data . . . . .	78-80
<b>42D</b>	
Model Number Nomenclature . . . . .	81
AHRI Capacity Ratings . . . . .	81
Physical Data . . . . .	82
Base Unit Dimensions . . . . .	83-87
Electrical Data . . . . .	88-90
<b>42S</b>	
Model Number Nomenclature . . . . .	91
AHRI Capacity Ratings . . . . .	92
Physical Data . . . . .	92
Base Unit Dimensions . . . . .	93-100
Accessory Dimensions . . . . .	101-105
Performance Data . . . . .	106-111
Electrical Data . . . . .	112,113
Guide Specifications . . . . .	114-125
Index . . . . .	126

\*BACnet is a Registered trademark of ASHRAE (American Society of Heating, Refrigerating, and Air-Conditioning Engineers).

## 42D ducted units

A drip lip (removable drain pan extension) is available for field installation on ceiling models 42DA,DC,DE and DF. The drip lip is recommended for all ceiling models when a valve package is installed.

Motor/blower assembly can be easily removed from the unit for ease of service. Removing this assembly provides clear access to the entering air face of the coil, making coil cleaning a relatively simple matter. Removable panels make access to components and connections easy.

## 42S stacked units

Carrier units can be factory equipped with insulated supply, return, and drain risers. The design of the 42S units allows them to be set one on top of the other in a vertical column rising floor to floor up the building. Each riser has a 3-in. belled section at the top, so the riser piping can be connected by only one sweat connection per riser. Field-installed couplings or internal pipe connections are not needed.

Each stack unit is constructed of heavy gage galvanized steel and factory pre-wired with all control, motor, and optional electric heat wiring conveniently terminating in a single, accessible junction box. Each stack unit requires only one field power connection.

Field-mounted accessories, such as the 3-speed switch/thermostat package for furred-in units, are equipped with a pre-wired quick disconnect plug for easy installation.

The riser size for the stack units can be specified to match building requirements so that cutting, sorting, and handling of the risers is not necessary. All units arrive tagged as specified by the customer for efficient delivery to the correct building location.

Units can be loaded onto delivery trucks so that they can be off-loaded in the proper installation sequence.

The 42SG furred-in-stack is a single unit, designed for concealed applications in corners or along room walls. The return-air grille is removable to allow access for servicing major components.

The 42SG is also available in master/slave unit pairs, shipped individually installed and piped together in the field. The master unit includes risers with stub out for field piping connections to the slave unit which has no risers of its own.

The 42SJ back-to-back furred-in stack is designed for installation in the separation wall between 2 rooms. The unit consists of 2 units factory assembled together with a common riser chase, piped to a set of common risers. Each unit has its own valves and controls.

The return-air grille is removable to allow access for servicing major components.

The 42SH cabinet stack unit is designed for applications where concealed installations are not possible or practical. This model features a powder coat painted cabinet with a double-deflection supply-air grille and an integral return-air grille access panel. Controls are normally mounted on the unit but may also be remote wall mounted.

The 42SU universal furred-in stack is designed for easy field configuration utilizing laser cut knockouts. Riser, drain, supply, and outside-air knockouts have been strategically located on the unit for field configuration. Prior to unit installation, all risers are shipped separately from the units for pre-installation and testing purposes.

The 42SM mega furred-in stack unit is designed for applications requiring units with increased capacity. The 42SM is designed to deliver 1400 to 2000 CFM at 0.5 in. ESP (external static pressure). Although usually installed in a small mechanical closet, the unit also features an optional decorative return air panel to allow for a classic high-rise type application. The unit's high static capability will easily handle high-efficiency air filters and decorative supply grilles, while the modular design provides quiet operation.

\* Registered trademark of ASHRAE (American Society of Heating, Refrigerating, and Air-Conditioning Engineers).

# Features/Benefits (cont)

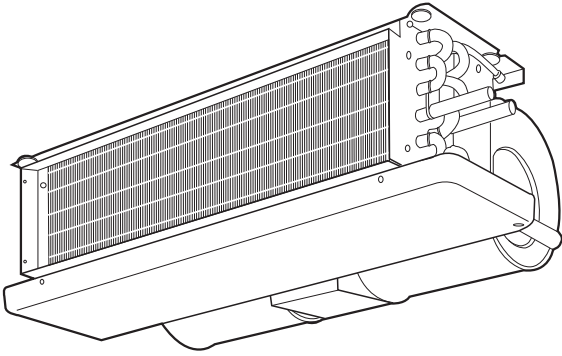

**42CA**  
Furred-in ceiling model with low silhouette.  
(200-1200 cfm)

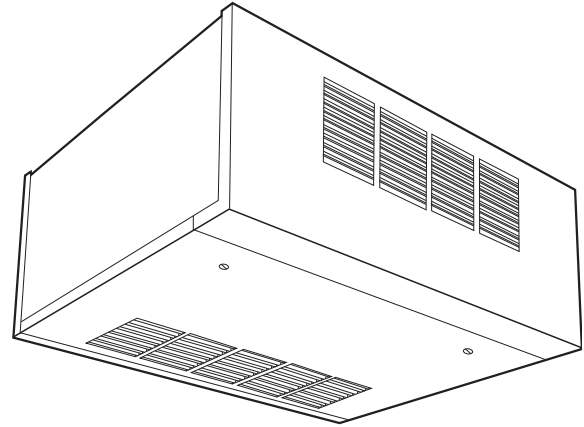

**42CG**  
Cabinet model for under-ceiling mount with  
bottom or rear stamped louver return air grille.  
(200-1200 cfm)

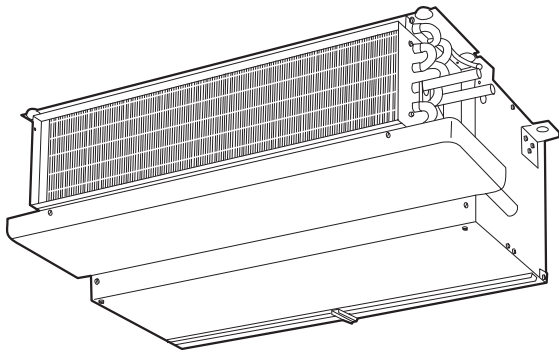

**42CE**  
Furred-in ceiling model with factory-installed  
plenum.  
(200-1200 cfm)

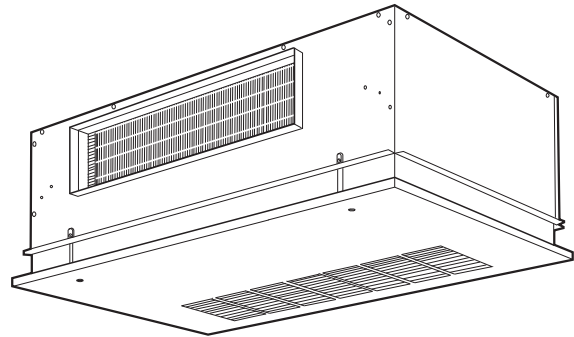

**42CK**  
Cabinet model with telescoping flip-down panel  
and stamped louver bottom return or duct  
collar rear return.  
(200-1200 cfm)

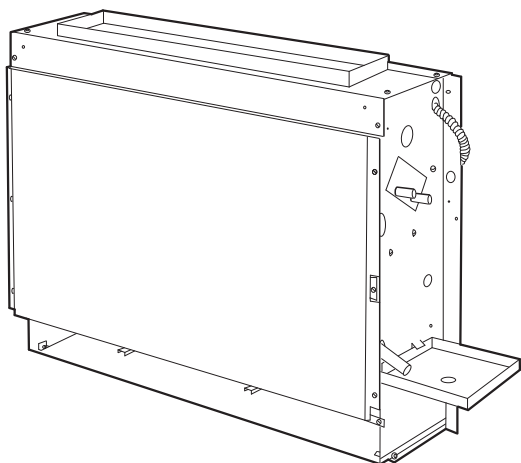

**42VAC**

Furred-in model for concealed applications, typically along the building perimeter, with top or front discharge.  
(200-1200 cfm)

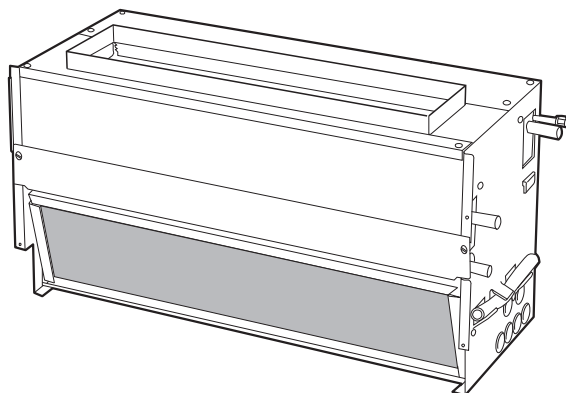

**42VCA**

Furred-in lowboy model for concealed under-the-window applications.  
(200-600 cfm)

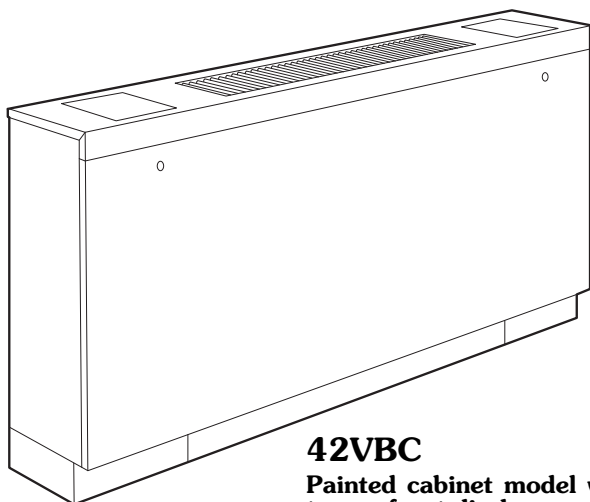

**42VBC**

Painted cabinet model with top or front discharge.  
(200-1200 cfm)

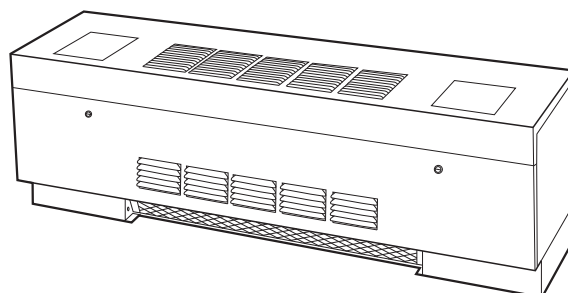

**42VEA**

Cabinet lowboy model with stamped lower discharge grille and 2 control access doors.  
(200-600 cfm)

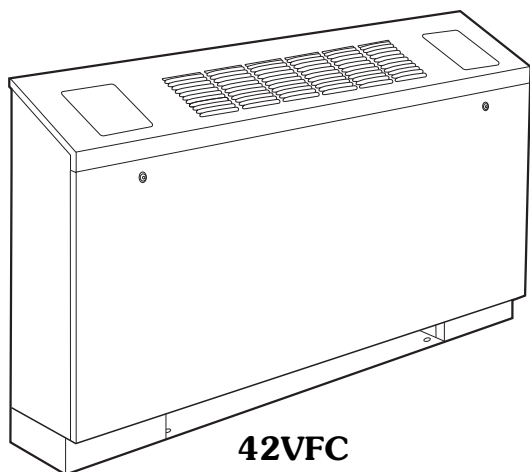

**42VFC**

Painted cabinet model with slant top and top or front discharge.  
(200-1200 cfm)

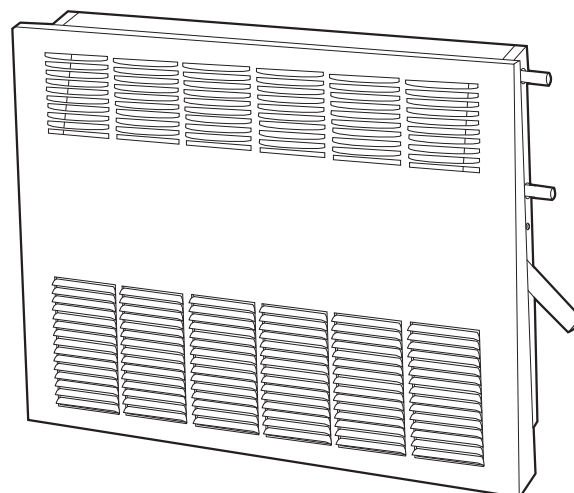

**42VGA**

Furred-in wall model. Available with a 10-in. valve compartment extension.  
(150 and 300 cfm)

# Features/Benefits (cont)

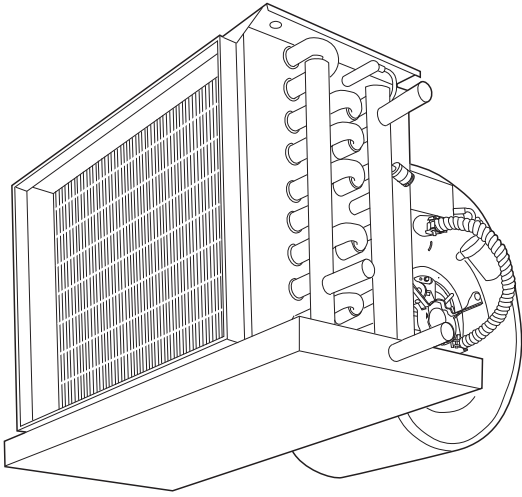

**42DA**  
Furred-in model for installation in the ceiling for high static applications.  
(600-2000 cfm)

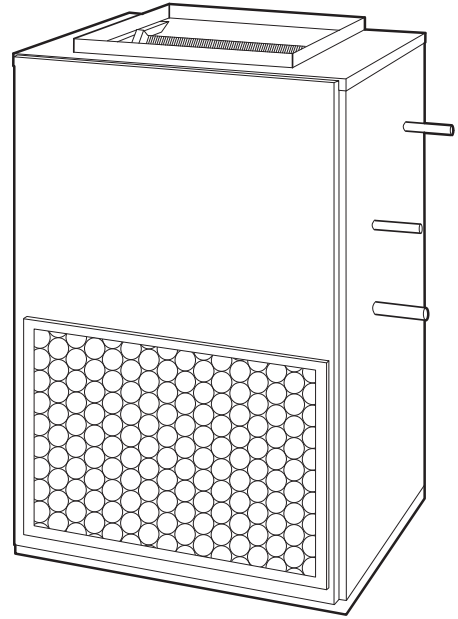

**42DD**  
Vertical model with galvanized casing. Commonly for closet installation.  
(600-2000 cfm)

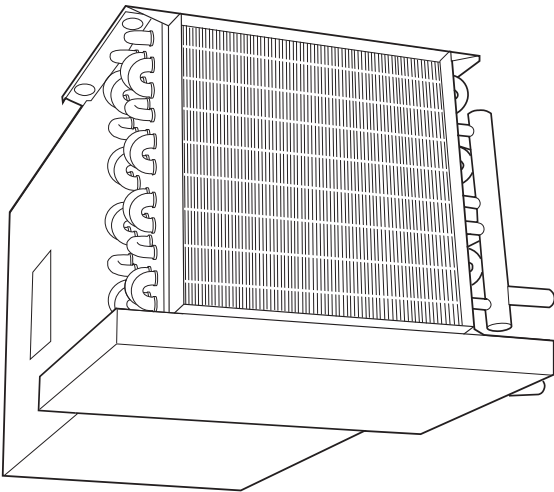

**42DC**  
Furred-in ceiling model with factory-installed insulated plenum.  
(600-2000 cfm)

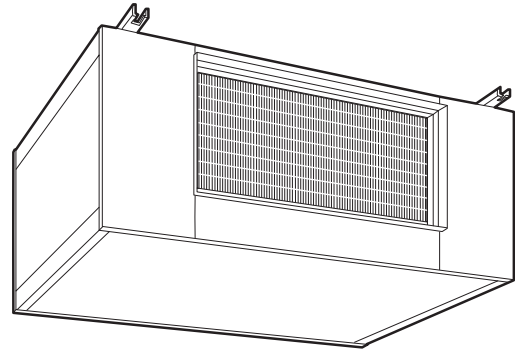

**42DE**  
Ceiling model with galvanized casing for ducted applications.  
(600-2000 cfm)

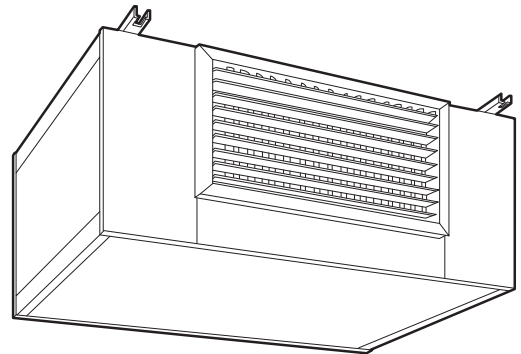

**42DF**  
Exposed-ceiling painted cabinet model with integral double-deflection discharge grille and a bar-type return-air grille for non-ducted applications  
(600-2000 cfm)

**42SG — Furred-in-stack**  
(300-1200 cfm)

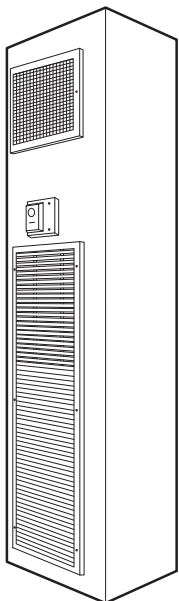

**42SJ — Back-to-back furred-in stack**  
(300-1200 cfm)

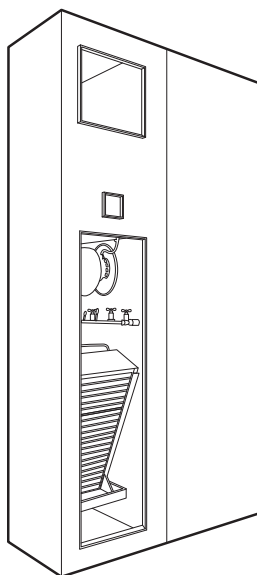

**42SH — Cabinet stack**  
(300-1200 cfm)

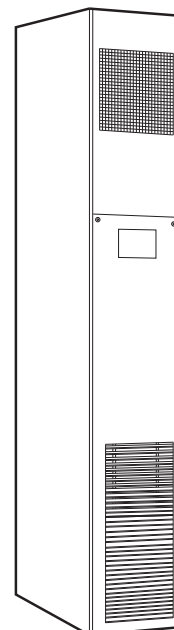

**42SU — Universal furred-in-stack**  
(300-1200 cfm)

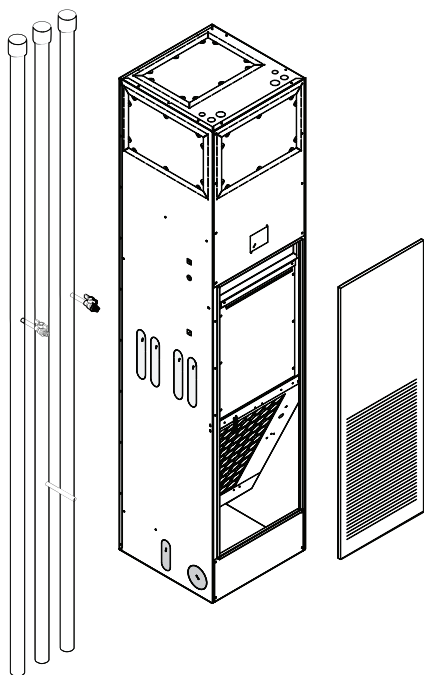

**42SM — Mega furred-in-stack**  
(1400-2000 cfm)

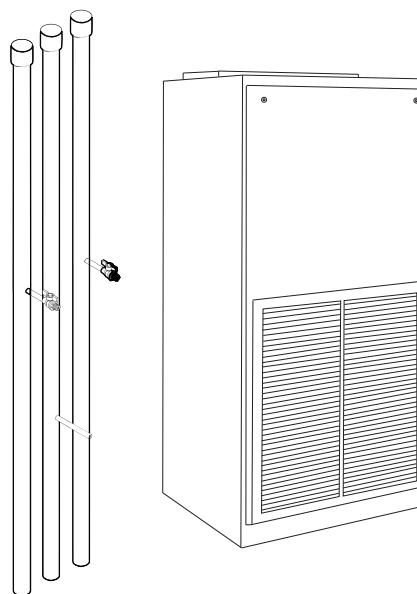

## AVAILABLE OPTIONS

OPTIONS OR STANDARD FEATURES*	UNIT SERIES — 42																			
	Ceiling — Horizontal				Vertical Floor						Ducted — Horizontal						Stack — Vertical			
	CA	CE	CG	CK	VA	VB	VF	VC	VE	VG	DA	DC	DE	DF	DD	SG	SH	SJ	SU	SM
<b>AIR VENT</b>																				
Automatic Air Vent	X	X	X	X	X	X	X	X	X	X	X	X	X	X	X	X	X	X	X	X
Manual Air Vent	Std	Std	Std	Std	Std	Std	Std	Std	Std	Std	Std	Std	Std	Std	Std	Std	Std	Std	Std	Std
<b>CABINET CHANGES</b>																				
Extended Cabinet Height								X	X											
Valve Compartment Extension, 10 in.										X										
<b>COILS</b>																				
2-Row (Cooling Only)	X	X	X	X				Std	Std	Std										
3-Row (2-Row Cooling, 1-Row Heating)								X	X											
3-Row (Cooling/Heating Only)	Std	Std	Std	Std	Std	Std	Std	X	X		X	X	X	X	Std	Std	Std	Std	X	
4-Row (3-Row Cooling, 1-Row Heating)	X	X	X	X	X	X	X				X	X	X	X	X	X	X	X	X	X
4-Row (Cooling/Heating Only)	X	X	X	X	X	X	X				Std	Std	Std	Std	Std	X	X	X	X	Std
5-Row (Cooling/Heating Only)																				X
5-Row (4-Row Cooling, 1-Row Heating)	X	X	X	X	X	X	X				X	X	X	X	X	X	X	X	X	X
5-Row (3-Row Cooling, 2-Row Heating)	X	X	X	X	X	X	X				X	X	X	X	X	X	X	X	X	X
6-Row (4-Row Cooling, 2-Row Heating)											X	X	X	X	X					
6-Row (Cooling/Heating Only)											X	X	X	X	X					
7-Row (6-Row Cooling, 1-Row Heating)											X	X	X	X						
8-Row (6-Row Cooling, 2-Row Heating)											X	X	X	X						
Stainless Steel Coil Wrapper	X	X	X	X	X	X	X	X	X	X	X	X	X	X	X	X	X	X		
<b>OUTSIDE AIR OPTIONS</b>																				
Motorized Damper					X	X	X									ETO	ETO	ETO		ETO
Manual Damper					X	X	X	X	X							X	X	X		X
Outside-Air Knockouts																				Std
Outdoor-Air Connection		ETO	ETO	ETO				X	X			ETO	ETO	ETO	ETO					
<b>DECORATIVE COLORS</b>																				
Custom Colors Available Upon Request			ETO	ETO		ETO	ETO		ETO	ETO				ETO			ETO			
Arctic White Powder Coat Paint			Std	Std		Std	Std		Std	Std				Std			Std			
<b>DISCHARGE OPTIONS</b>																				
Stamped Discharge Grille			Std		Std	Std	Std		Std	Std										
Double Deflection Grille, Factory-Installed†			X		X	X	X		X					Std						
Double Deflection Grille, Shipped Loose†			X					X							Std	Std	Std	X	X	
Discharge Duct Collar	Std	Std		Std				Std			Std	Std	Std		Std	Std	Std		Std	
Discharge Knockouts																				Std
<b>DRAIN PANS</b>																				
Galvanized Drain Pan	Std	Std	Std	Std	Std	Std	Std	Std	Std	Std	Std	Std	Std	Std	Std	Std	Std	Std	Std	
Extended Drain Pan	X	X									X	X								
Stainless Steel Standard Drain Pan	X	X	X	X	X	X	X	X	X	X	X	X	X	X	X	X	X	X	X	Std
Stainless Steel Extended Drain Pan	X	X									X	X								
Tell-Tale Only	X	X	X	X							X	X	X	X						
Drip Lip Only	X	X	X	X							X	X	X	X						
Tell-Tell and Drip Lip	X	X	X	X							X	X	X	X						
<b>HEATING OPTIONS</b>																				
Electric Heater	X	X	X	X	X	X	X	X	X		X	X	X	X	X	X	X	X	X	X
Hot Water	X	X	X	X	X	X	X	X	X		X	X	X	X	X	X	X	X	X	X
Steam	ETO	ETO	ETO	ETO				ETO	ETO		ETO	ETO	ETO	ETO	ETO					

**LEGEND**

- EC — Electronically Commutated
- ETO — Engineered to Order
- PSC — Permanent Split Capacitor
- Std — Standard
- X — Available as Options

\*All options are factory-installed unless noted as shipped loose.  
 †Standard grille is steel; option is available as steel or aluminum.



**AVAILABLE OPTIONS (cont)**

OPTIONS OR STANDARD FEATURES*	UNIT SERIES — 42																			
	Ceiling — Horizontal				Vertical Floor						Ducted — Horizontal					Stack — Vertical				
	CA	CE	CG	CK	VA	VB	VF	VC	VE	VG	DA	DC	DE	DF	DD	SG	SH	SJ	SU	SM
<b>FILTERS</b>																				
1-in. Permanent Filters		X	X	X	X	X	X	X	X			X	X		X	X	X			
1-in. Throwaway Filters		Std	Std	Std	Std	Std	Std	Std	Std	Std		Std	Std	Std	Std	Std	Std	Std	Std	Std
1-in. MERV 7 Pleated												X	X		X					
1-in. MERV 8 Pleated		X	X	X	X	X	X									X	X	X	X	X
1-in. MERV 13 Pleated					X	X	X													X
2-in. MERV 8 Pleated					X	X	X													
2-in. MERV 13 Pleated					X	X	X													
<b>LEVELING LEGS</b>					X	X	X	X	X						X					
<b>INSULATION</b>																				
Foil Faced Insulation	X	X	X	X	X	X	X	X	X	X	X	X	X	X	X	X	X	X		X
Fiberglass Insulation	Std	Std	Std	Std	Std	Std	Std	Std	Std	Std	Std	Std	Std	Std	Std	Std	Std	Std	Std	Std
Closed Cell Insulation		X	X	X	X	X	X	X	X	X										
Premium IAQ Fiberglass	ETO	ETO	ETO	ETO				ETO	ETO	ETO	ETO	ETO	ETO	ETO	ETO	ETO	ETO	ETO		ETO
<b>MOTORS - PSC</b>																				
115-1-60, 3-Speed	Std	Std	Std	Std	Std	Std	Std	Std	Std	Std	Std	Std	Std	Std	Std	Std	Std	Std	Std	Std
208-1-60, 3-Speed	X	X	X	X	X	X	X	X	X		X	X	X	X	X	X	X	X	X	X
230-1-60, 3-Speed	X	X	X	X	X	X	X	X	X		X	X	X	X	X	X	X	X	X	X
277-1-60, 3-Speed	X	X	X	X	X	X	X	X	X		X	X	X	X	X	X	X	X	X	X
220-1-50, 3-Speed	X	X	X	X	X	X	X	X	X		X	X	X	X	X	X	X	X		
<b>MOTORS - EC</b>																				
115-1-60	X	X	X	X	X	X	X	X	X		X	X	X	X	X	X	X	X	X	X
208-1-60	X	X	X	X	X	X	X	X	X		X	X	X	X	X	X	X	X	X	X
230-1-60	X	X	X	X	X	X	X	X	X		X	X	X	X	X	X	X	X	X	X
277-1-60	X	X	X	X	X	X	X	X	X		X	X	X	X	X	X	X	X	X	X
220-1-50	X	X	X	X	X	X	X	X	X		X	X	X	X	X	X	X	X	X	X
<b>MOTOR QUICK-DISCONNECT PLUG</b>	Std	Std	Std	Std	Std	Std	Std	Std	Std		Std	Std	Std	Std	Std	Std	Std	Std	Std	Std
<b>INTEGRAL THERMAL OVERLOAD PROTECTION</b>	Std	Std	Std	Std	Std	Std	Std	Std	Std	Std	Std	Std	Std	Std	Std	Std	Std	Std	Std	Std
<b>RETURN AIR GRILLE, Shipped Loose</b>																				
Stamped Return Grille				Std	Std		X	X		Std	Std					Std	Std	Std	Std	X
Hinged Panel														Std						
<b>TAMPERPROOF LOCKS</b>																				
Access Panels				Std	Std		Std	Std		Std				Std	Std		Std	Std	Std	Std
Control Access Doors							X	X		X										
<b>VALVE PACKAGES</b>	X	X	X	X	X	X	X	X	X	X	X	X	X	X	X	X	X	X	X	X
<b>WIRING PACKAGES</b>	X	X	X	X	X	X	X	X	X	X	X	X	X	X	X	X	X	X	X	X

**LEGEND**

- EC — Electronically Commutated
- ETO — Engineered to Order
- PSC — Permanent Split Capacitor
- Std — Standard
- X — Available as Options

\*All options are factory-installed unless noted as shipped loose.  
 †Standard grille is steel; option is available as steel or aluminum.

# Options (cont)



## Factory-installed options

**Coils** — Choice of a 2-pipe or 4-pipe system with the following chilled/hot water coil configurations:

COIL CONFIGURATION	UNIT			
	42C	42D	42S	42V
<b>2-Row Coil</b>	•	ETO	ETO	—
<b>3-Row Coil</b>	•	•	•	42VAC, VBC, VCA, VEA, VFC only
<b>4-Row Coil</b>	•	•	•	42VAC, VBC, VFC only
<b>5-Row Coil</b>	—	—	42SM only	—
<b>6-Row Coil</b>	—	•	—	—
<b>8-Row Coil*</b>	—	ETO	—	—
<b>Opposite End Coil Connections</b>				
<b>3/1</b>	•	•	•	42VAC, VBC, VFC only
<b>3/2</b>	•	•	•	42VAC, VBC, VFC only
<b>4/1</b>	•	•	•	42VAC, VBC, VFC only
<b>4/2</b>	—	•	—	—
<b>6/1</b>	—	42DA,DC, DE,DF only	—	—
<b>6/2</b>	—	42DA,DC, DE,DF only	—	—
<b>Same End Coil Connections</b>				
<b>2/1</b>	—	—	—	42VCA, VEA only
<b>3/1</b>	•	•	•	42VAC, VBC, VFC only
<b>3/2</b>	•	•	•	42VAC, VBC, VFC only
<b>4/1</b>	•	•	•	42VAC, VBC, VFC only
<b>4/2</b>	—	•	—	—
<b>6/1</b>	—	42DA,DC, DE,DF only	—	—
<b>6/2</b>	—	42DA,DC, DE,DF only	—	—
<b>Cu/Cu Coil Special Option*</b>	ETO	ETO	ETO	ETO

### LEGEND

- Available
- Not Available
- ETO Engineer to Order

\*Needs quote control.

**Seismic compliance options** — Several models have been tested and approved for installations requiring IBC or OSHPD seismic certification. Submit special quote for verification of unit compliance.

**Condensate overflow switch** — This switch shuts down the unit when the water level in the drain pan reaches an unsafe level. Building code changes in many locales now require this type of device.

**Decorative colors** — Standard color is Arctic White. Custom colors may be provided when matched with a provided paint chip. Special quote required for custom colors.

Decorative colors may be applied to:

- Cabinet of 42VBC, VFC, VEA, VCA

- Cabinet of 42CG
- Panels of 42SH
- Bottom panels of 42CK
- Cabinet of 42DF

**Electric heaters** — Coils are of high grade single-phase, nichrome resistance wire, insulated by ceramic insulators in plated steel brackets. Heater sizes available are shown in the application data section for the respective units. Not available on 42VGA units.

**Filters** — Each unit (except the 42CA, DA units) includes a non-woven synthetic throwaway filter sized for low velocity and maximum efficiency. The standard option will filter both return and outside air. For optional filters, please refer to available option table on pages 8 and 9.

**Fusing** — Incoming power fusing, as well as blower motor and control sub-fusing for units that use electric heat. The blower motor and control sub-fusing (single power source wiring) is required when single source power with electric heat is specified.

**Manual air vents** — Each standard coil includes a manual air vent to allow venting at the coil if necessary for quick, complete air elimination.

**Motors** — Three-speed PSC (permanent split capacitor) motors are offered as standard, providing the ability to adjust airflow to meet varying load conditions. High-static PSC motors are available as an option for applications requiring higher external static capability. ECM (electronically commutated) motors are optional on all units except 42VG. ECM motors offer programmable features, low sound, and increased energy efficiency. Refer to the application data section for more information on ECM control methods.

**Outside-air opening/damper** — Damper is adjustable from 0 to 25% and provides ventilation air to unit. (Manual/motorized damper available on 42SG, SH, SJ, SM units.)

**Service switches** — Concealed service switches are available for use by maintenance and service personnel to shut off the power while working on the unit.

**Single power source connection** — Factory-installed junction box allows use of single power source for motor and heater when they are of the same voltage.

**Stamped toe space return-air grille** — The return-air grille is available as a factory-installed option for 42VBC and 42VFC units.

**Tamperproof fasteners (Allen head)** — Tamperproof fasteners are installed on the access panels and are available for all cabinet model units.

**Thermostat control packages** — We offer a variety of control devices to meet the most basic to the most demanding operating logic. All of our control schemes utilize 3-speed fan control to modulate cooling output, maximize the percentage of latent heat removal, and to further reduce the sound level when maximum cooling and heating performance is not required. The standard thermostat control option is line voltage except on 42SU and 42SM, which include a low voltage control package as standard. Unit-mounted line voltage and 24-v thermostats

are available on the 42V Series units. For thermostat control package options refer to pages 13-15.

### Field-installed accessories

**Automatic air vents** — Automatic air vents have fiber washers which allow air in the pipes to pass through, automatically bleeding the system, and eliminating the need to manually remove air from the system. When wet, washers swell and seal the system.

**Drip lips (removable drain extension)** — Drip lips are frequently used when valves are added after unit installation and space limitations will not permit use of an extended drain pan. The drip lip is placed on the end of the drain pan and is pitched toward the pan to ensure proper drainage. The drip lip gives positive control of condensate from valves and controls.

**Panels, frames, and grilles** — Panels, frames, and grilles on the 42S Series units can be chosen in a wide variety of combinations to suit room decorating requirements and allow access to the unit for maintenance. Discharge grilles are double deflection type, aluminum finish or painted. Return-air access panels containing return-air grilles are available in five different types as illustrated on pages 102 and 103.

#### PANELS, FRAMES AND GRILLES

PANEL NO.	DESCRIPTION
1	Standard, heavy gage galvanized steel. Coated with powder-coat Arctic White finish. Attached to unit with 1/4 turn fasteners.
2	Heavy gage galvanized steel. Coated with powder-coat Arctic White finish. Includes access door for concealed unit-mounted controls.
3	Bar-type extruded aluminum with frame matching double deflection supply grille. Fastens to wall and unit with 1 1/2 in. long screws.
4 and 5	Heavy gage galvanized steel. Coated with powder-coat Arctic White finish. Frame mounted on sheetrock with screws. Panel mounted in frame with 1/4 turn fasteners.
All	Each panel provides access to all internal components.

**Return-air grilles** — Stamped-type return-air grilles are standard on 42CG,CK,VE,VG,SG,SH,SJ,SU units and optional on 42VBC,VFC,SM units. Anodized aluminum hinged bar-type grilles are installed on 42DF units.

**Risers** — The 42S Series units can accommodate 3/4-in. (supply and return) and 1-in. (drain) to 2 1/2-in. riser sizes in 2-pipe systems. For other applications, such as reverse return risers or 4-pipe systems, it may be necessary to accommodate the additional risers.

Condensate drains are available in sizes down to 1-in. for greater cost economy. Riser size-reducers are factory-installed on 42SG, SJ, and SH. For risers over 119-in. long, extension pieces can be furnished for field installation.

NOTE: Risers for the 42SU,SM units are shipped separately for field installation and testing before the unit is installed.

**Riser expansion** — The 42S Series units are built to accommodate modest expansion of the external riser. This only allows for expansion between the unit and the riser. This allowance for movement within the unit is not intended to replace necessary riser expansion compensation devices that the consulting engineer may deem advisable for the external riser system. External riser expansion/contraction compensation and anchoring are the responsibility of the consulting engineer and the installing contractor.

**Risers material and insulation** — The 42S Series unit supply, return, and drain risers can be furnished in type M or L copper. All factory-furnished risers are insulated with flexible closed foam insulation in 1/2-in. or 3/4-in. thickness.

**Discharge grilles** — Two types of double deflection discharge grilles are available for 42CG, VBC, VFC, VEA units; an integral steel grille painted to match the unit or a separate unpainted anodized aluminum grille. Optional discharge air grilles for 42S Series units are suitable for side-wall application, and available in clear anodized aluminum or Arctic White finish. The aluminum discharge grilles are suitable for air dry field painting. The discharge grille frame and blades are 6063 extruded aluminum alloy with 200-R1 satin anodized finish. The frame has a typical wall thickness of 0.050-in. and is separated from the blades with injection-molded nylon bushings. This method of assembly minimizes corrosion and vibration. The frame mounting holes are dimpled, allowing for a counter-sunk fastener head appearance. All blades are airfoil in design, individually adjustable and spaced 3/4-in. on center. At the outer edge of the frame is a specifically engineered channel which retains an extruded flexible vinyl bulb gasket that produces a positive air seal at the mounting surface, minimizing smudging. An optional opposed blade damper is screwdriver operated through the face of the unit and has the same extruded aluminum construction and injection-molded nylon bushings. The unit achieves an effective area of 80% with the blades set at a 0 degree pattern, thus eliminating high velocity and pressure drop at the grille face. Wider deflection with reduced throw may be achieved at the 22 and 45 degree blade settings with slightly increased sound levels.

**Tell-tale drain pan** — A secondary drain connection is located above the primary drain to act as a “tell-tale” in the event that the primary drain becomes obstructed. They can be applied to either the main drain pan or an extended main drain pan. This option is only available on the 42C and 42DA, DC, DE, DF units.

**Thermostats control packages** — Wall-mounted line voltage and 24-v thermostats are available on the 42 Series fan coil units. For thermostat control packages options refer to pages 13-15.

# Options (cont)

**DRIP LIP**  
(Horizontal Unit)

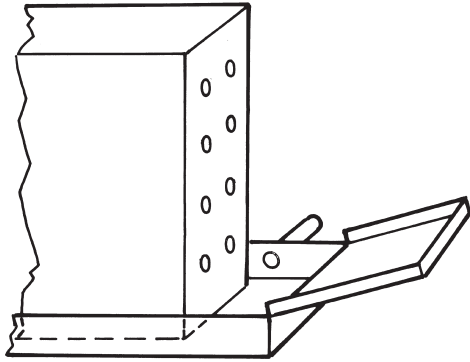

**"TELL-TALE" DRAIN PAN**  
(Horizontal Unit)

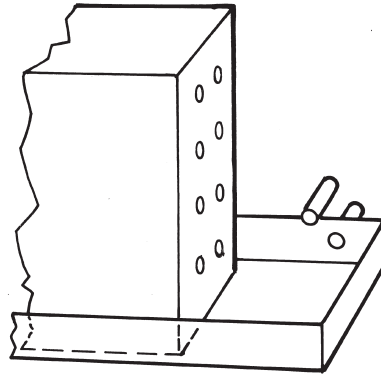

# Controls



Use the Control Selection Guide table to make sure that all necessary components are provided for and that the components are compatible with the required control system.

NOTE: When thermostatic fan control is selected or when unit outside-air dampers are used, unit-mounted thermostats are not recommended as their use will result in poor room temperature sensing.

## CONTROL SELECTION GUIDE

SYSTEM		DESCRIPTION	THERMOSTAT	CHANGEOVER ON SUPPLY PIPE	VALVE	FAN SWITCH	NOTES
2-PIPE HEATING-COOLING*	Fan Control (2-pipe)	Fan manually cycled	None	None	None	3-Speed switch	Not recommended for high humidity application
	Two-Position Electric Valves (2-pipe)	Thermostat cycles valve open or closed.	Wall or unit mounted includes heat-cool switch.	None	Motorized (N.C.) 3-way or 2-way, no bypass required.	Thermostat has integral 3-speed switch	Valve packages with belled end(s) for field soldering to coil.
		Thermostat cycles valve open or closed. Mode automatically switched by changeover sensing water temp.	Wall or unit mounted. Heating/cooling Thermostat	Yes	Motorized (N.C.) 3-way or 2-way	Thermostat has integral 3-speed switch	
ELECTRIC HEAT	Two-Position Electric Valve with Auxiliary Electric Heat (2-pipe)	Thermostat cycles valve open or closed. Thermostat activates electric heater. Heater cannot turn on if hot water is in coil.	Wall or unit mounted. Sequenced heating and cooling.	Yes. Two Required.	Motorized 3-way or 2-way	Thermostat has integral 3-speed switch	Valve packages with belled end(s) for field soldering to coil.
	Two-Position Electric Valve with Total Electric Heat (2-pipe)	Thermostat cycles valve open or closed. Thermostat activates electric heater.	Wall or unit mounted. Sequenced heating and cooling.	None	Motorized (N.C.) 3-way or 2-way, no bypass required	Thermostat has integral 3-speed switch	Valve packages with belled end(s) for field soldering to coil.
4-PIPE	Two-Position Electric Valves (4-pipe)	Thermostat cycles cooling valve open or closed. Thermostat cycles heating valve open or closed.	Wall or unit mounted. Sequenced heating and cooling.	None	Motorized (N.C.) 3-way or 2-way (requires 2 valves)	Thermostat has integral 3-speed switch	Valve packages with belled end(s) for field soldering to coil.

### LEGEND

N.C. — Normally Closed

\*If system is HEATING-ONLY or COOLING-ONLY, no changeover or bypass is required.

NOTE: Unit-mounted thermostats are not recommended with either fan-cycle control or applications with outside-air dampers.

# Controls (cont)



## Remote-mounted controls

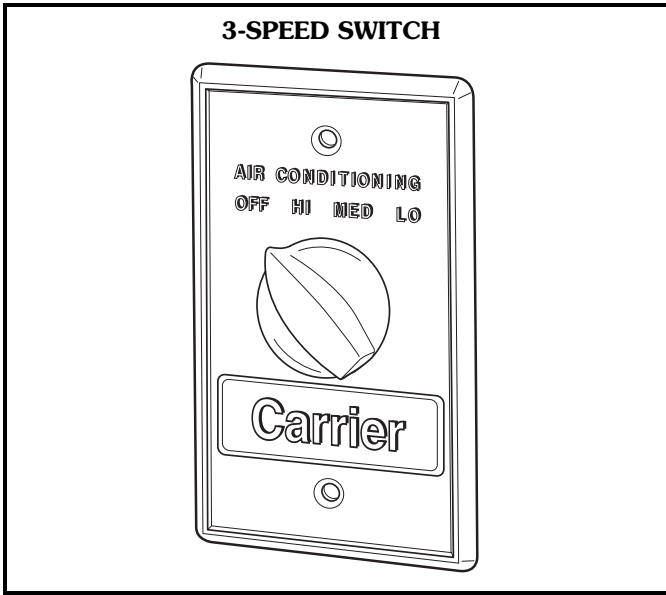

**Wall mounted 3-speed switch** — This switch has 4 positions: OFF, HIGH, MEDIUM, and LOW. Switch has auxiliary contact that is energized when switch is in HIGH, MEDIUM or LOW position.

Some of the options common with the 3-speed switch are:

1. Unit-mounted switch on furred-in vertical model. (Available as special order on horizontal models.)
2. Switch without OFF position.

## Optional remote-mounted thermostat or unit-mounted 24-v thermostat

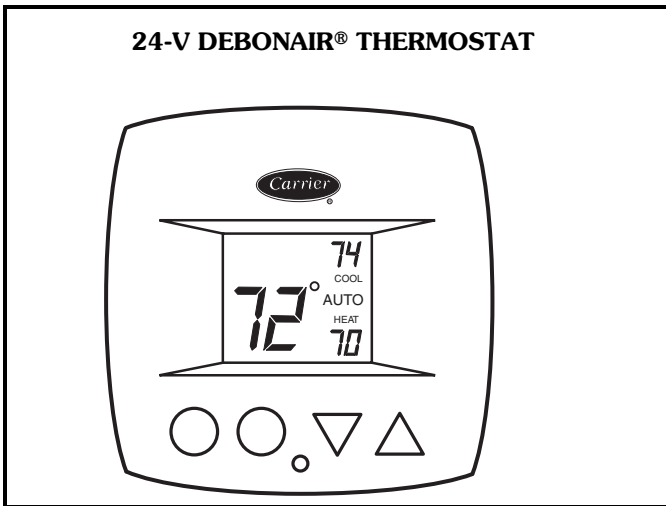

**24-v Debonair thermostat** — Features large Thermo-glow™ display, Neverlost™ memory, Smart Fan™ dynamic fan speed control, 4-pipe, 2-pipe automatic changeover applications with adjustable dead band. Programmable and non-programmable models available.

## Optional remote-mounted line-voltage thermostat

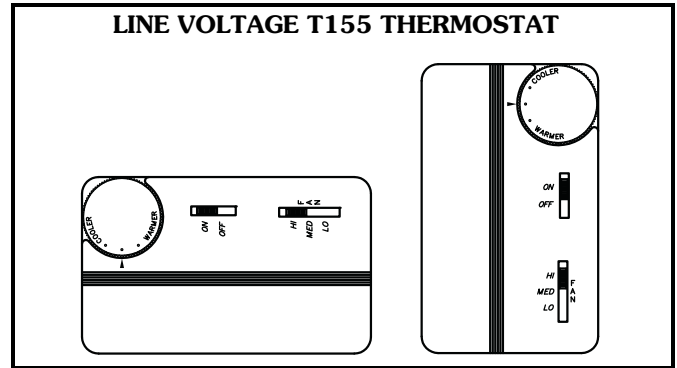

**Line voltage T155 thermostat** — Features 50 to 90 F temperature range, manual 3-speed fan control, mount is a standard 2 x 4 in. box, 4-pipe, 2-pipe and autochangeover applications. Available in vertical or horizontal styles.

## Unit-mounted controls

**Line voltage controls by others** — Unit supplied with wiring for valve cycle operation, including changeover sensors (as required) for use with field-installed line voltage thermostats.

**24-v controls by others** — Unit supplied with factory-installed 24-v transformer, 3-speed relay board, and aquastat (as required) for use with field-installed low voltage controls.

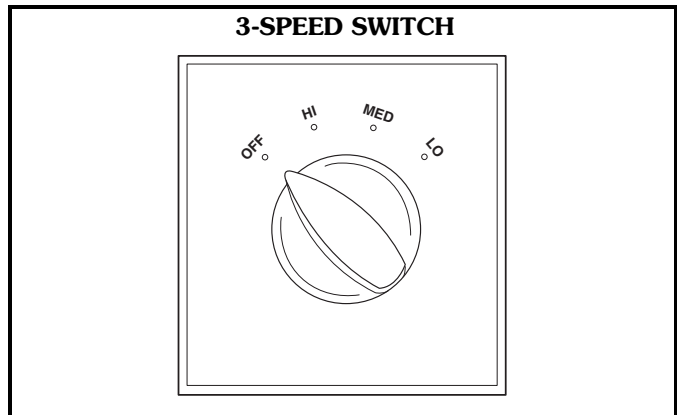

**Unit-mounted 3-speed switch** — Switch has OFF, HIGH, MED and LOW positions. Switch is also equipped with auxiliary connection energized when switch is in HIGH, MED or LOW position.

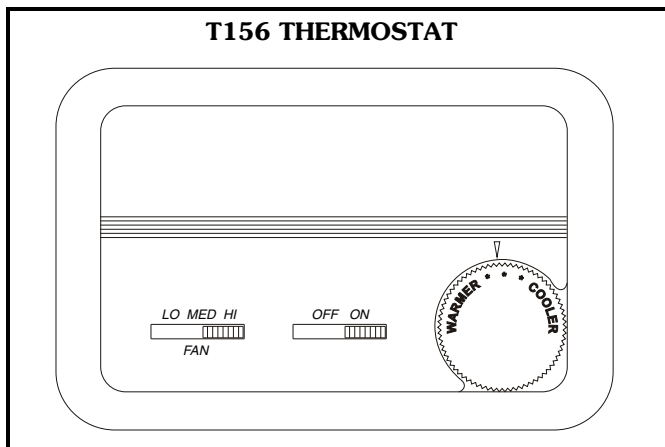

**Line voltage T156 thermostat** — Includes thermostat for 2-pipe or 4-pipe system and manual 3-speed fan control. The special combination allows for the fan coil unit to have control for the valve cycle only. This thermostat is only available for unit-mounted line voltage applications.

**Integrated Direct Digital Controls (DDC)**

**Fan Coil Open controller** — The factory-mounted controller continuously monitors and regulates the fan coil operation with reliability and precision. This advanced controller features a sophisticated, factory engineered control program that helps provide optimum performance and energy efficiency. The fan coil open controller also features plug-and-play connectivity to Carrier’s i-Vu® Open control system. For added flexibility, the fan coil controller is capable of stand alone operation, or can be integrated with any Building Automation System (BAS) utilizing BACnet protocol. Application features include built-in advance control routines for zone level humidity control, zone level demand ventilation (ASHRAE 62) and automatic fan speed control based on demand. System benefits include demand limiting for maximum energy saving, and compatibility with i-Vu control system tenant billing for tracking tenants after hours energy usage. Hardware features include onboard hardware clock, remote occupancy input, and support for space temperature thermistor sensor for stand alone operation.

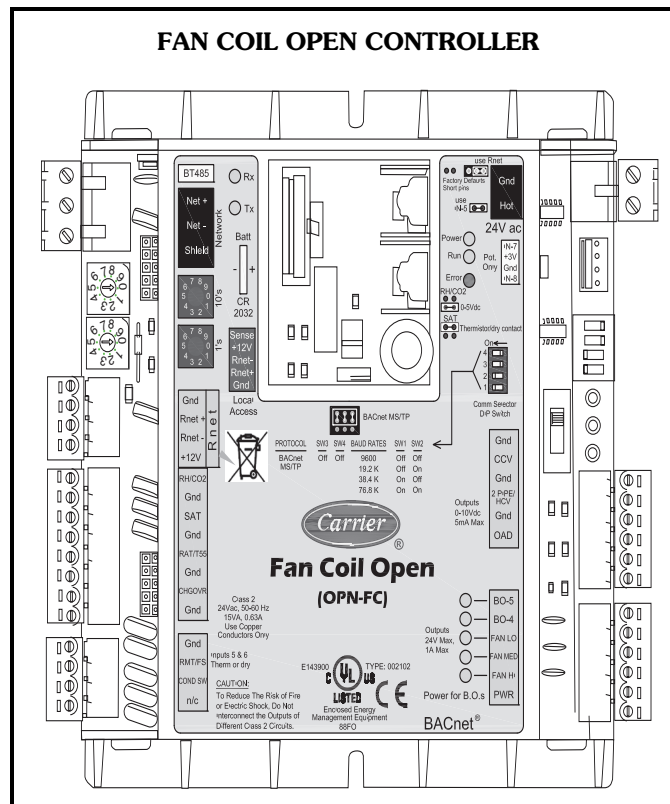

# Controls (cont)

## Automatic changeover (Summer-Winter switch) —

The automatic-changeover thermostat sensor is a 10,000-ohm thermistor (33ZCSENCHG) in a moistureproof and dust-proof enclosure. Cable and temperature sensing element are hermetically sealed in a polypropylene enclosure with epoxy resin. Device clamps on coil supply pipe with end snap-on clip.

The set point temperatures are factory set. When water temperature rises above 80 F (approximately), the sensor switches to the winter cycle. When water temperature drops below approximately 70 F, the sensor switches to the summer cycle. Switch reset is automatic.

**Fan coil control relay board —** The fan coil relay board is used in conjunction with the Debonair thermostat or a controller or the Fan Coil Open controller to regulate a single-speed or multi-speed fan. The fan coil relay board can also be used to connect the fan coil controller to a line voltage valve actuator.

The fan coil relay board is factory shipped as a PC board with four 1/2-in. stand-offs attached for field mounting.

NOTE: One fan coil relay board is used for each application. Fan coils with two or more fan motors use a fan coil relay board for each fan motor. A maximum of three fan coil relay boards can be wired to one fan coil control.

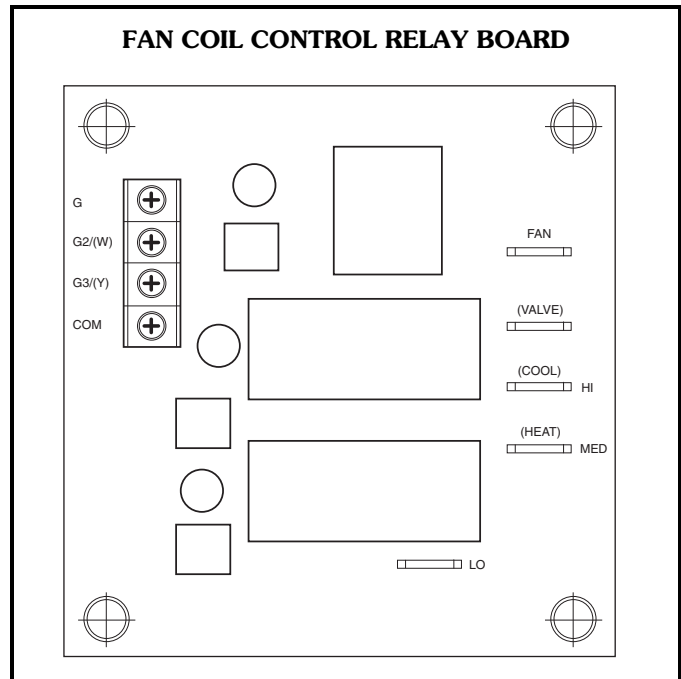



# Selection procedure

Refer to the Carrier Electronic Selection Program for information to determine unit sizing for your needs.

## Application data

### Basic definitions

**Unit hand** — When facing the supply air outlet from the front of the unit (air blowing in your face), your right hand will be the right hand side of the unit and your left hand the left hand side of the unit.

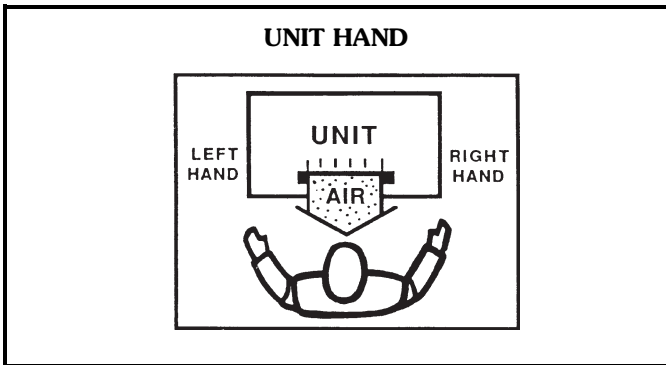

**Same end connection (2 pipe or 4 pipe)** — All piping connections are on the same end (side) of the unit. Controls and electrical connection will be on the end (side) opposite the piping connection.

Standard 2-pipe units will be the same end connection.

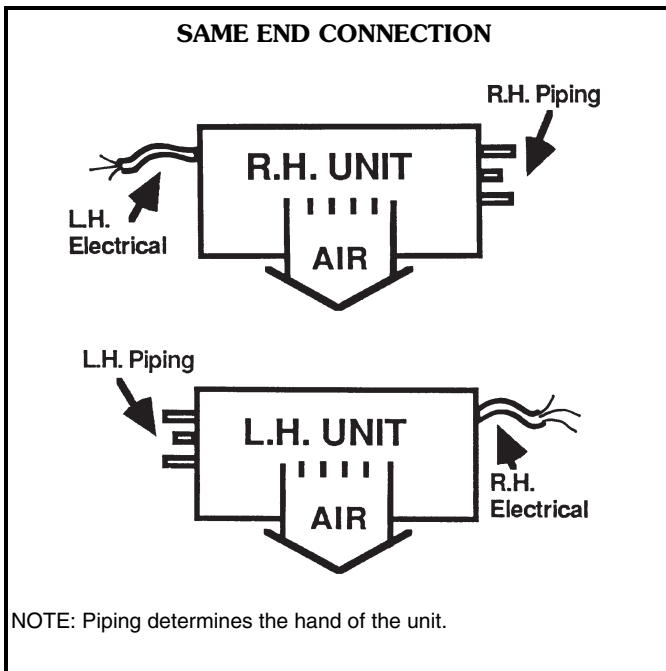

**Opposite end connection (4-pipe option)** — Hot water (HW) piping connections and electrical will be on the end (side) opposite the chilled water (CW) and drain connections.

**4-Pipe coil arrangement** — For 4-pipe coil combination chilled water/hot water coils, the hot water coil is in the reheat position. For 4-pipe combination DX (direct expansion)/hot water coils, the hot water is in the preheat position. The opposite hot water coil position is available through quote control.

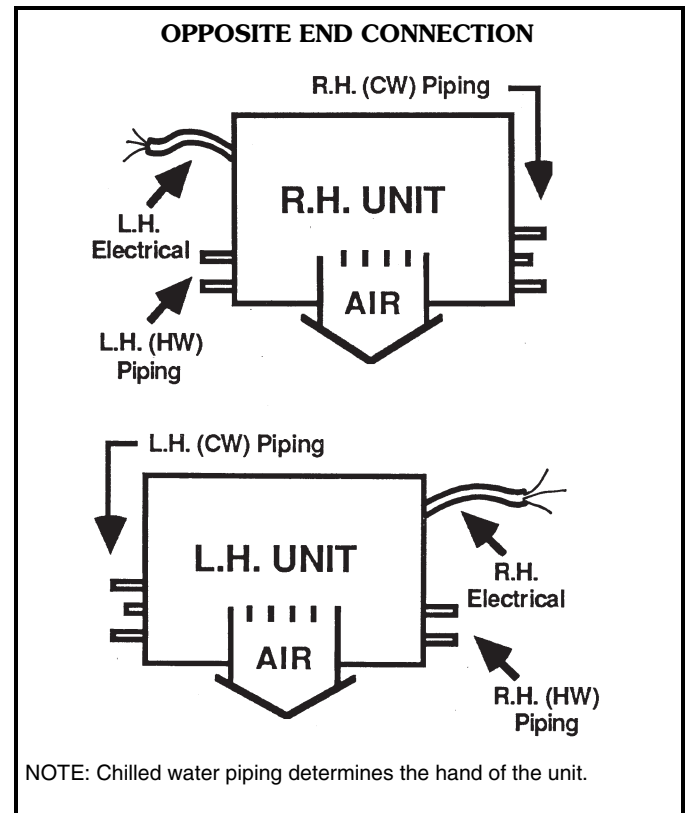

# Application data (cont)

## System piping

The following diagrams show some common methods used to pipe the 42S Series units. Only the 2-pipe systems are shown; however, the methods would be the same for 4-pipe systems.

System 1, the “direct return” system, is the most common. It is economical to install since it supplies and returns the water for a riser column from the same location, at the top or the bottom of a building. This type of riser arrangement does require more attention to individual unit water flow balancing. The risers are normally capped at the end as shown in the diagrams.

System 2, the “reverse return” system, is used to minimize the requirement for individual unit balancing. This system is usually referred to as the self-balancing system. The arrangement of the risers allows the water flow for each unit in a column to be equalized. In the reverse return system both the supply and return mains are located at the top or the bottom of a building requiring an additional return riser to be furnished in the units.

System 3, the “common reverse return” system, typically has the supply and return mains located remotely from each other — such as one at the top and one at the bottom of a building. This eliminates the need for a reverse return riser in the units.

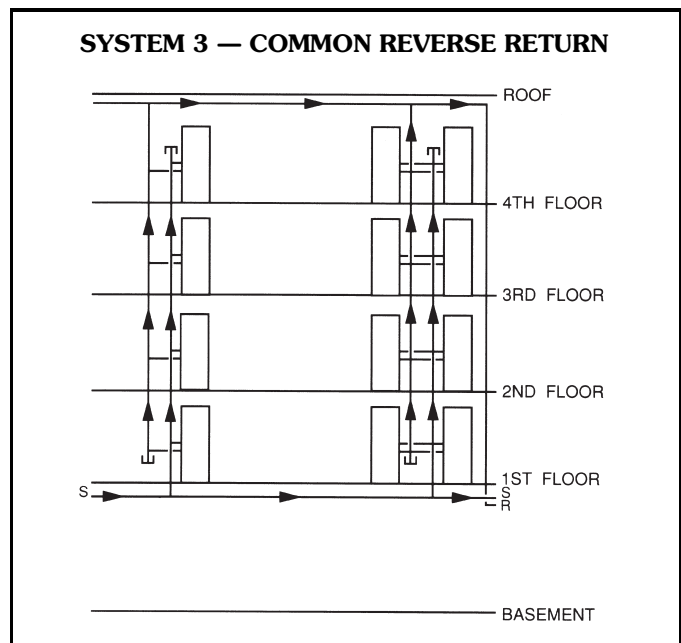
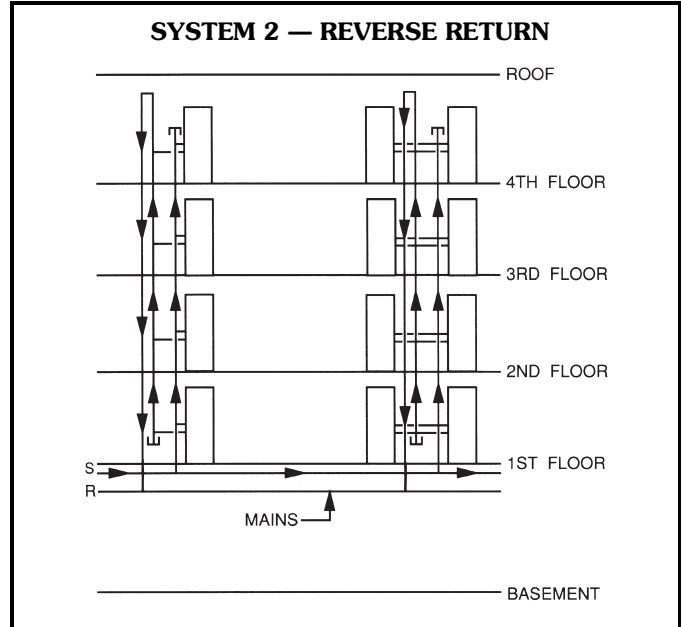
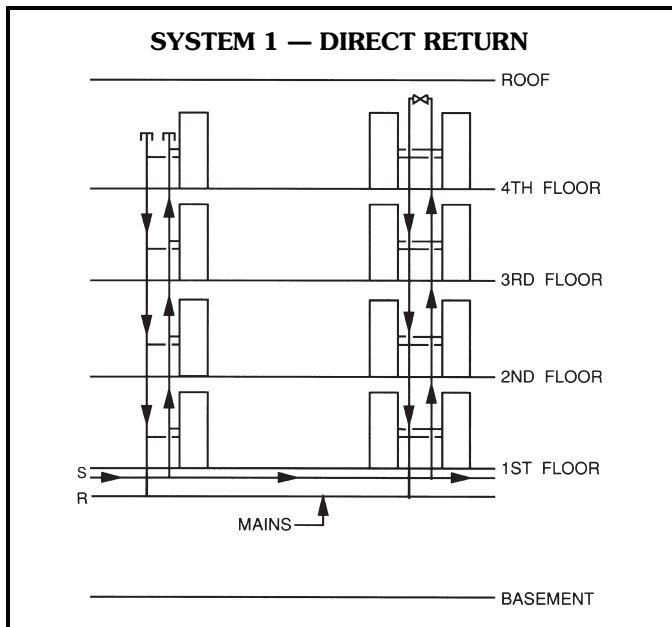

## Risers (42S units)

Riser diameter is an important consideration in the design of stack series systems. Standard units can accommodate  $\frac{3}{4}$ -in. to  $2\frac{1}{2}$ -in. riser sizes in 2-pipe systems. For other applications, such as reverse return risers or 4-pipe systems, it may be necessary to accommodate the additional risers.

Riser size is based on the water flow needed for a given tier of units. Unit risers are sized according to the diameter and length requirements as specified by the customer. To determine riser size, water velocity should be limited to 5 to 8 ft per second. Thus, if 10 units are to be stacked vertically with each unit requiring 3 gpm, the maximum flow in the risers is 30 gpm. Through  $1\frac{1}{4}$  in. risers, this is a velocity of 7.5 ft per second. The maximum flow rate of 30 gpm occurs only at the supply and return points. As the water moves upward, the flow in the supply riser is reduced

by 3 gpm per floor, so that after 3 floors, the total flow is 21 gpm and riser size can be reduced to one inch. See the Main Riser Pressure Drops chart on page 111.

Condensate drains are available in sizes down to 1 in. for greater first cost economy.

Riser size-reducers are factory installed and caps are provided at customer request except for 42SU units.

For risers of over 119 in. length, extension pieces can be furnished for field installation.

## Typical arrangements

Typical arrangement applications for each model type are shown on page 20. The fan coil units feature almost an unlimited number of arrangements to meet the needs of new construction, renovation, or reconstruction. Consult the factory for the arrangement (standard or special) to meet your particular need.

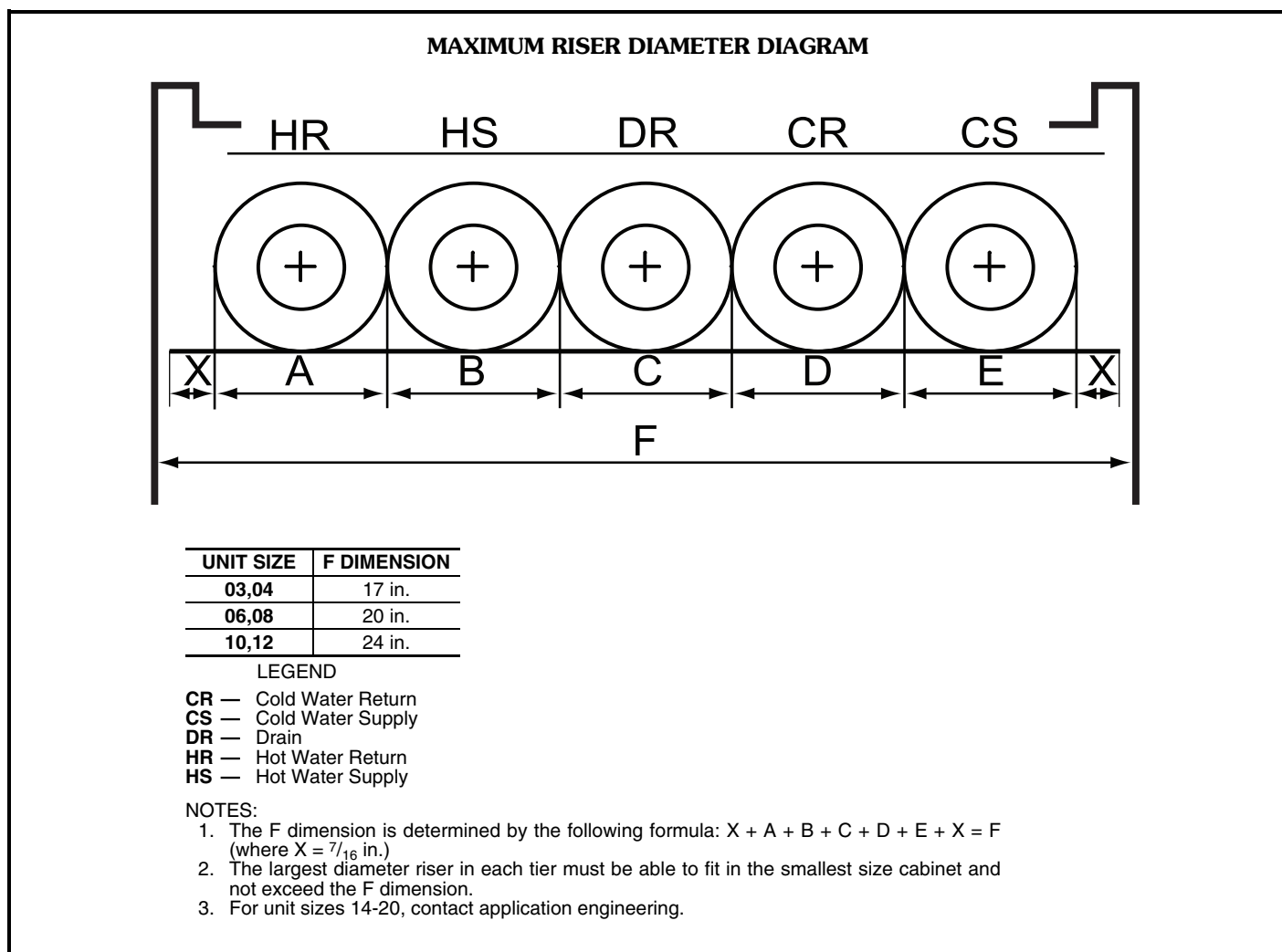

## TYPICAL ARRANGEMENT APPLICATIONS

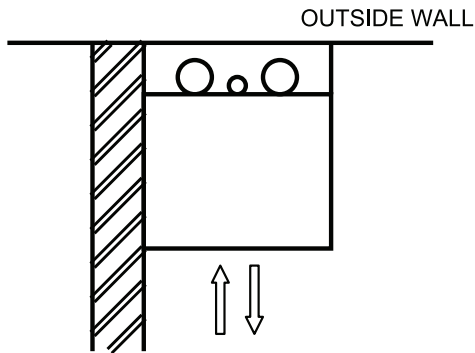

**42SH - EXPOSED CABINET**

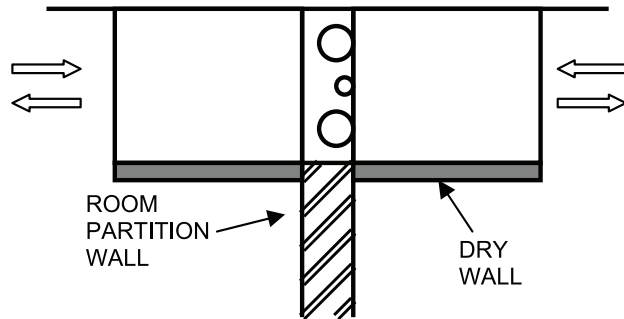

**42SJ - BACK-TO-BACK FURRED-IN STACK**

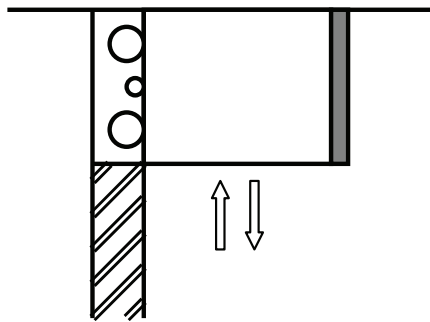

**42SG - FURRED-IN STACK**

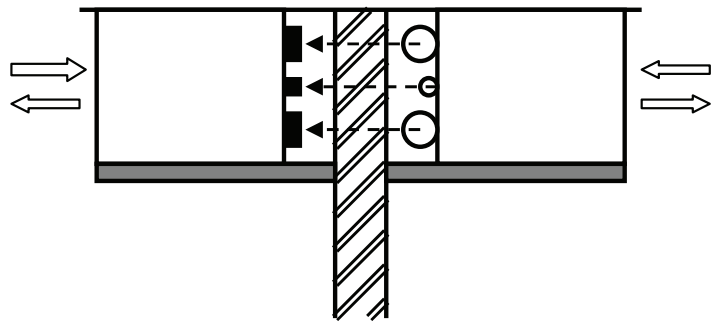

**42SG - FURRED-IN STACK MASTER/SLAVE**

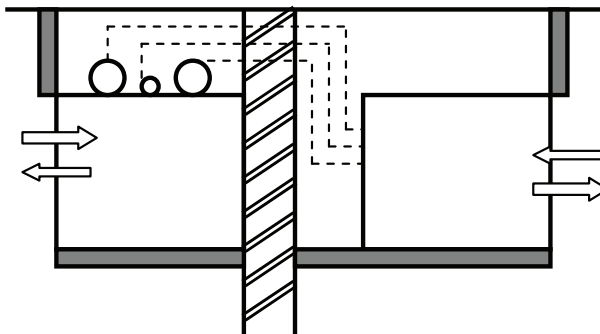

**42SG - FURRED-IN-STACK X-MASTER**

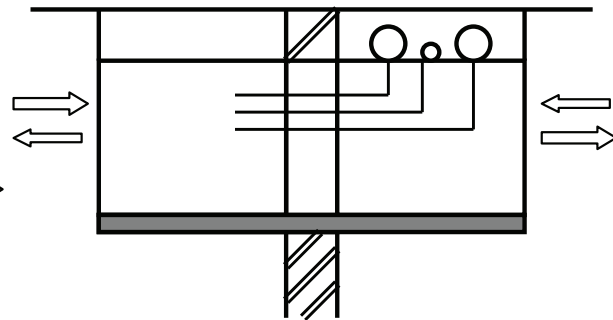

**42SG - FURRED-IN-STACK SIAMESE**

### 42SU ARRANGEMENT OPTIONS

One of the unique traits of the Universal Stack (42SU) is the variety of possible unit arrangements. The best unit design configuration can be selected by choosing from numerous unit arrangement options that utilize knockout designs while conserving floor space and reducing installation costs.

Below are just a few pictorials of the many arrangement possibilities of the 42SU fan coil system.

NOTE: Risers ship separately. Units are field connected to risers using factory furnished flex hoses.

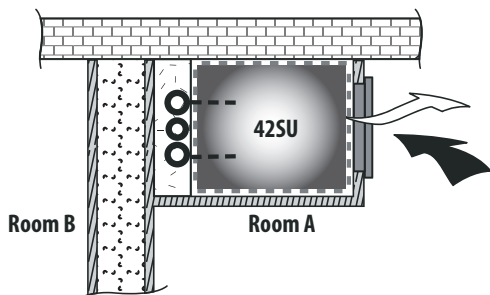
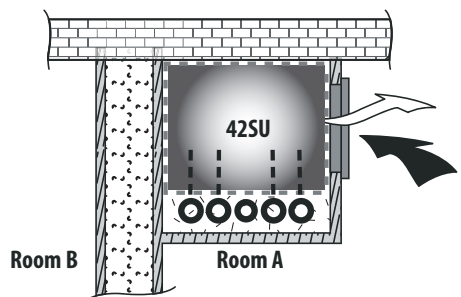
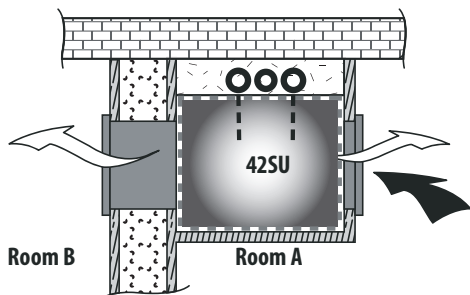
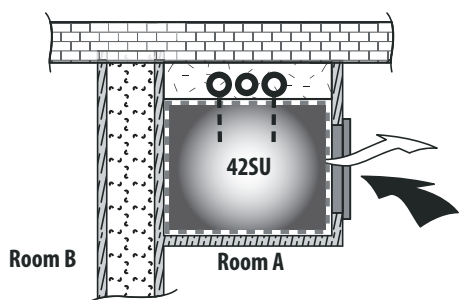

#### LEGEND

- Exterior Wall
- Field Sheetrock
- Separation or Utility Chase
- Universal Stack Unit
- Partition (or Separation) Wall
- Hoses for Field Installation
- Supply Air
- Return Air

The Supply, Return, and Drain risers (2-pipe or 4-pipe applications) can be oriented on any of three sides of the unit.

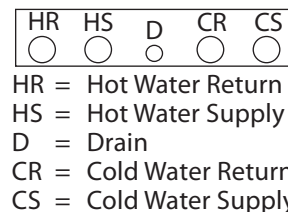
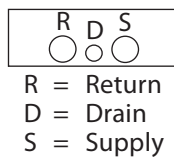
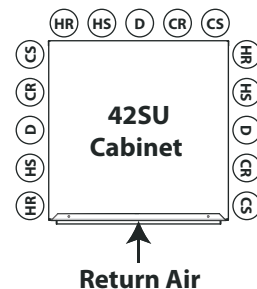

2-pipe

4-pipe

## 42SM UNIT CONFIGURATION OPTIONS

Mega Stack units (42SM) are designed to be installed either in a small mechanical closet or furred in with drywall adhered directly to the cabinet. One of the unique traits of the 42SM unit is its optional discharge plenum. The discharge plenum is a factory-installed option that adds 22-in. to the unit height and provides multiple air duct or supply-air grille connections.

The designer is afforded the luxury of specifying a single unit, which can duct to multiple spaces, direct discharge to a single space, or provide a combination of the two. If necessary, the plenum is added or removed in the field to accommodate design changes.

Below are a few of the many arrangement possibilities of the 42SM fan coil system.

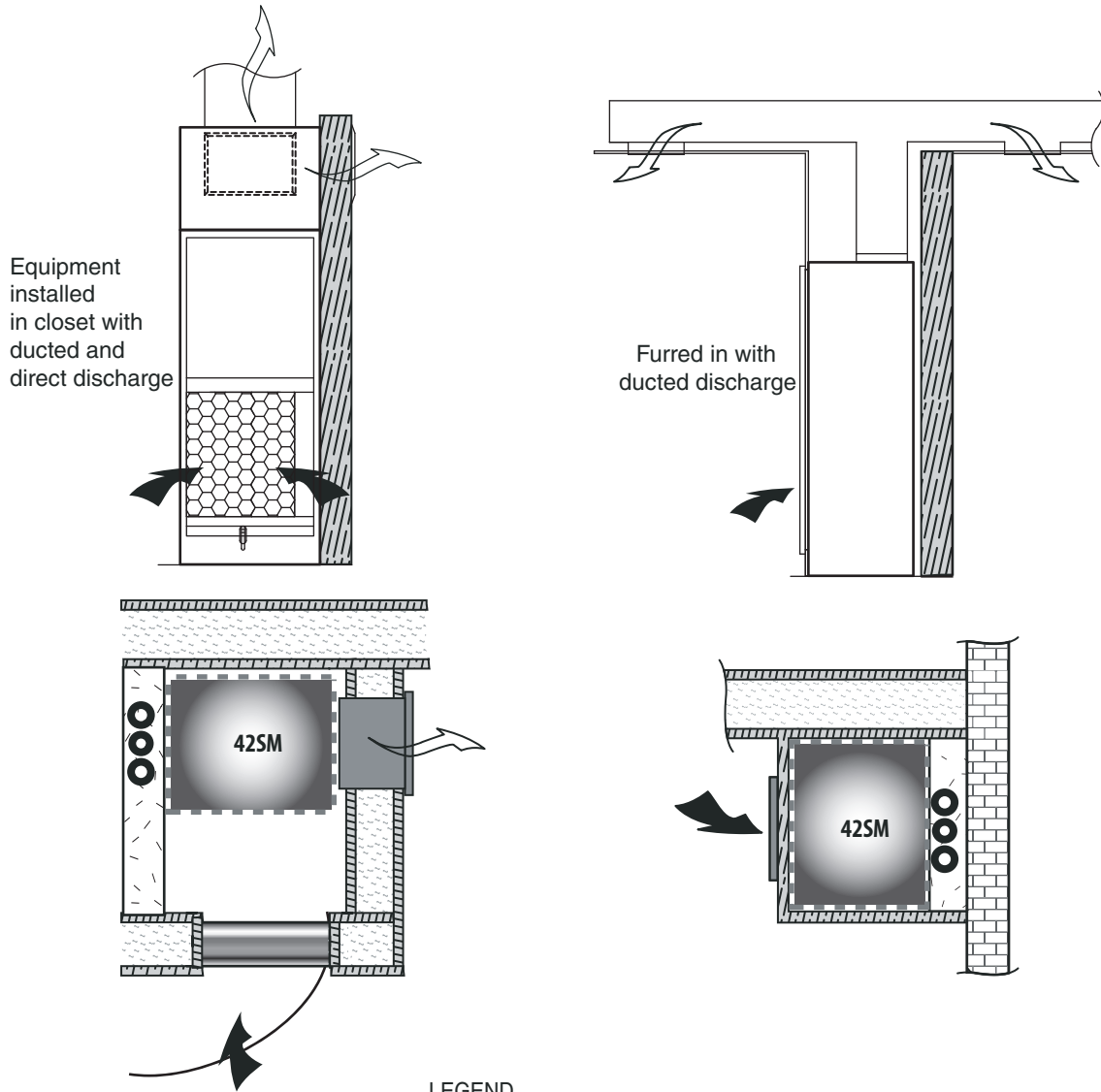



### LEGEND

- |                             |                                |
|-----------------------------|--------------------------------|
| Exterior Wall               | Partition (or Separation) Wall |
| Field Sheetrock             | Supply Air                     |
| Separation or Utility Chase | Return Air                     |
| Mega Stack Unit             | Field Installed Risers         |

NOTE: Risers ship separately. Units should be field connected using factory furnished flex hoses.

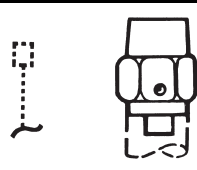
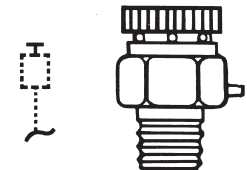
### PIPING COMPONENTS

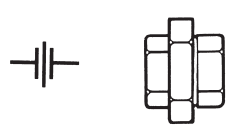
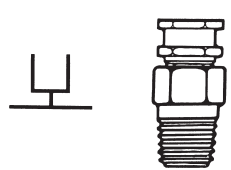
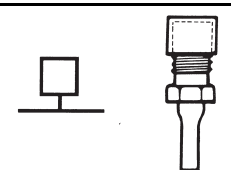
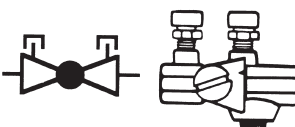
SYMBOL/SKETCH	DESCRIPTION	C <sub>v</sub> FACTOR		RATING*		STEAM USE
		1/2	3/4	PSI	F	
	<p><b>MANUAL AIR VENT:</b> Threaded brass needle valve with screwdriver slot for adjustment.</p> <p>Application — Body brazed into high point of heating and cooling coils for bleeding air from coil. Standard item on all hydronic coils (not used on steam or DX coils). Should not be used in lieu of main system air vents.</p>	N/A	N/A	400	100	NO
	<p><b>AUTOMATIC AIR VENT:</b> Nickel plated brass valve, fiber-disc type, with positive shut-off ball-check and quick vent feature via knurled vent screw.</p> <p>Application — Optional replacement for manual air vent. Automatically passes minute quantities of air through the fiber discs which expand upon contact with water, completely sealing the valve. As air accumulates, the fiber discs dry and shrink, repeating the cycle. Not recommended for removing large quantities of air encountered during initial start-up or subsequent draining and refilling. Should not be used in lieu of main system air vents.</p>	N/A	N/A	125	240	NO
	<p><b>SWAGE:</b> Copper tube end expanded to accept a copper tube of the same size for factory or field brazing.</p> <p>Application — Used where possible for all tubing joints for best joint integrity.</p>	N/A	N/A	300	200	YES
	<p><b>UNION:</b> Combination wrought copper/cast brass union assembly, solder by solder.</p> <p>Application — Used for quick connect (and disconnect) of valve package components to minimize field labor and facilitate servicing of unit.</p>	N/A	N/A	300	200	YES
	<p><b>INSERTION TEST PORT:</b> Brass body valve for acceptance of test probe (up to 1/8 in. diameter).</p> <p>Application — Installed on one (or both) sides of the coil to allow for temperature or pressure sensing. Used for close tolerance water balancing and service analysis.</p>	N/A	N/A	250	250	NO
	<p><b>PRESSURE TEST PORT:</b> Brass body 1/4 service access fitting with removable depressor type core.</p> <p>Application — Installed on both sides of the coil to allow for pressure sensing. Attach pressure gages to facilitate close tolerance water balancing.</p>	N/A	N/A	400	210	NO
	<p><b>CIRCUIT SETTER:</b> Variable water flow balancing valve with manual adjustment knob, pointer, percent-open scale, memory stop and integral pressure read-out ports.</p> <p>Application — Used for close tolerance water flow balancing. Positive shut-off ball valve feature allows usage as combination balancing and shut-off valve.</p>	2.12	3.9	300	250	NO

**LEGEND**



- C<sub>v</sub>** — Coefficient of Velocity
- DX** — Direct Expansion
- ETO** — Engineering to Order

\*Check all system component pressure ratings (coils, valves, pumps, etc.) with manufacturer and any applicable local or national piping codes prior to specifying system pressure rating.

# Application data (cont)

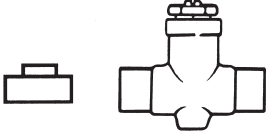
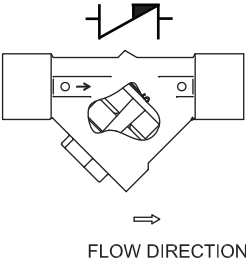

## PIPING COMPONENTS (cont)

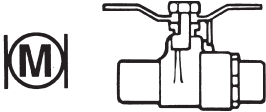
SYMBOL/SKETCH	DESCRIPTION	C <sub>v</sub> FACTOR		RATING*		STEAM USE
		1/2	3/4	PSI	F	
	<p><b>BALANCE VALVE:</b> Variable water flow manual balancing valve with screwdriver slot adjustment screw.</p> <p>Application — Often used in conjunction with test port fittings for water flow balancing. Balance by temperature differential or coil pressure drop (check specifications for service fittings required if balancing by pressure drop). May be used in 3-way valve bypass line to permit equal flow balancing.</p>	4	14	300	250	NO
 <p style="text-align: center;">FLOW DIRECTION →</p>	<p><b>FIXED FLOW VALVE:</b> Flexible orifice type (non-adjustable).</p> <p>Application — Used for water flow balancing. Valve automatically adjusts the flow to within 10% of set point.</p>	Valve orifice size determines C <sub>v</sub> factor. The orifice of these fixed flow valves changes as flow is regulated. As the water pressure increases, the orifice size decreases, thereby automatically limiting the flow rate to the specified gpm (±10%).		600	220	NO
	<p><b>STRAINER:</b> Y-type body with 20 mesh stainless steel screen.</p> <p>Application — Used for removal of small particles from system water during normal system operation. Should not be used in lieu of main system strainers. Strainer screen may have to be removed during initial high pressure system flushing during start-up. Screen should be removed and cleaned per normal maintenance schedule (provisions for strainer blow-down not provided).</p>	9.0 Clean	19.0 Clean	400	150	N/A
	<p><b>BALL VALVE WITH MEMORY STOP:</b> Manual balance and shut-off valve.</p> <p>Application — Used for unit isolation and water flow balancing. The adjustable memory stop feature allows return to the balance point after shut-off. Check specifications for service fittings required when used for water balancing.</p>	17	40	600	325	N/A







### LEGEND

- C<sub>v</sub>** — Coefficient of Velocity
- DX** — Direct Expansion
- ETO** — Engineering to Order

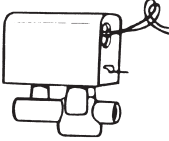
\*Check all system component pressure ratings (coils, valves, pumps, etc.) with manufacturer and any applicable local or national piping codes prior to specifying system pressure rating.

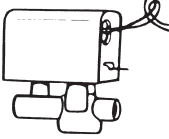

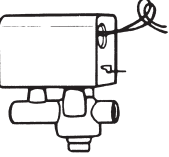
**PIPING COMPONENTS (cont)**

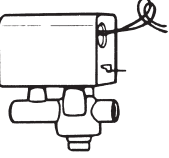
SYMBOL/SKETCH	DESCRIPTION	C <sub>v</sub> FACTOR		RATING*		STEAM USE
		1/2	3/4	PSI	F	
 	<p><b>2-WAY MOTORIZED VALVE (25 PSI close off differential pressure):</b> Electric 2-position flow control valve (open/closed). Normally closed body with manual override lever. Installed in supply line to unit.</p> <p>Application — All standard control and valve packages are based upon normally closed valves (valve electrically powered open and closed by spring return when electric power removed). Manual override lever allows valve to be placed in the open position for secondary (unit) flushing, constant water flow prior to start-up, etc. Manual override is automatically disengaged when valve is electrically activated. <b>Consult factory for normally open valve applications.</b></p>	3.5	3.5	300	200	YES 15 PSI MAX.
 	<p><b>2-WAY MOTORIZED VALVE (150 PSI close off differential pressure):</b> Electric 2-position flow control valve (open/closed). Normally closed body with manual override lever. Installed in supply line to unit.</p> <p>Application — All standard control and valve packages are based upon normally closed valves (valve electrically powered open and closed by spring return when electric power removed). Manual override lever allows valve to be placed in the open position for secondary (unit) flushing, constant water flow prior to start-up, etc. Manual override is automatically disengaged when valve is electrically activated. <b>Consult factory for normally open valve applications.</b></p>	4.9	10.3	300	240	NO
 	<p><b>3-WAY MOTORIZED VALVE (25 PSI close off differential pressure):</b> Electric 2-position flow control valve (closed to coil/ open to bypass or open to coil/closed to bypass). Normally closed with manual override lever. Installed in supply line to unit.</p> <p>Application — Same comments as 2-way motorized valve except with manual override lever engaged the valve is open to both ports and water flow will take the path of least resistance through the valve package (not necessarily 100% through the coil).</p>	4.0	4.0	300	200	N/A
 	<p><b>3-WAY MOTORIZED VALVE (150 PSI close off differential pressure):</b> Electric 2-position flow control valve (closed to coil/ open to bypass or open to coil/closed to bypass). Normally closed with manual override lever. Installed in supply line to unit.</p> <p>Application — Same comments as 2-way motorized valve except with manual override lever engaged the valve is open to both ports and water flow will take the path of least resistance through the valve package (not necessarily 100% through the coil).</p>	4.9	4.9	300	240	N/A

**LEGEND**



- Cv** — Coefficient of Velocity
- DX** — Direct Expansion
- ETO** — Engineering to Order

\*Check all system component pressure ratings (coils, valves, pumps, etc.) with manufacturer and any applicable local or national piping codes prior to specifying system pressure rating.

# Application data (cont)

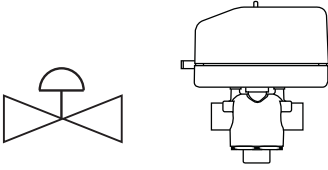
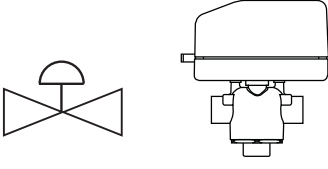
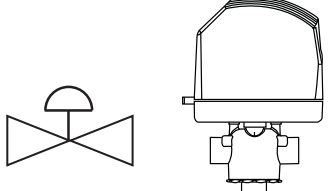
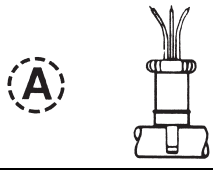

## PIPING COMPONENTS (cont)

SYMBOL/SKETCH	DESCRIPTION	C <sub>v</sub> FACTOR		RATING*		STEAM USE
		1/2	3/4	PSI	F	
	<p><b>MODULATING VALVE (Optional) (Non-Spring Return, Floating Point Actuator):</b> Modulating valves are designed to control the flow in the circuit by making incremental adjustments to the flow path within the valve.</p> <p>Application — To control fluid flow in fan coil units.</p> <p>On the 42DD,SG,SJ,SH commercial fan coil models, the factory provided modulating valve has application restrictions. In these models, the valve packages are located in the air-stream, downstream of the coil. Due to the ambient temperature limitations of the modulating valves, the valves can only be used in the units listed above with 2-pipe cooling only systems.</p>	4.0		300	200	N/A
	<p><b>MODULATING VALVE (Optional) (Non-Spring Return, Proportional Type Actuator):</b> Modulating valves are designed to control the flow in the circuit by making incremental adjustments to the flow path within the valve.</p> <p>Application — To control fluid flow in fan coil units.</p> <p>On the 42DD,SG,SJ,SH commercial fan coil models, the factory provided modulating valve has application restrictions. In these models, the valve packages are located in the air-stream, downstream of the coil. Due to the ambient temperature limitations of the modulating valves, the valves can only be used in the units listed above with 2-pipe cooling only systems.</p>	4.0		300	200	N/A
	<p><b>MODULATING VALVE (Requires ETO) (Spring Return):</b> Modulating valves are designed to control the flow in the circuit by making incremental adjustments to the flow path within the valve.</p> <p>Application — Same comments as non-spring return except when powered, the actuator moves to the desired position, at the same time tensing the spring return system. When power is removed for more than two minutes the spring returns the actuator to the normal position.</p>	4.0		300	200	N/A
	<p><b>AQUASTAT:</b> Water temperature sensing electrical switch. (Line Voltage Controls)</p> <p>Application — Clips directly on nominal size 1/2 in. or 3/4 in. copper tubing for water temperature sensing. Must be correctly located for proper control operation.</p>					
	<p><b>CHANGEOVER SENSOR:</b> Water temperature sensor thermistor.</p> <p>Application — Sensor shall clamp on the outside diameter of the pipe. Sensor plate shall bend to allow its radius to be adjusted to fit the pipe. Sensor shall be secured to the pipe with mounting clamp. Insulate the mounting location of sensor on the pipe.</p>					

### LEGEND

- C<sub>v</sub>** — Coefficient of Velocity
- DX** — Direct Expansion
- ETO** — Engineering to Order

\*Check all system component pressure ratings (coils, valves, pumps, etc.) with manufacturer and any applicable local or national piping codes prior to specifying system pressure rating.

## Valve packages

There are limitations on physical size of pneumatic valves, quantity and type of matching components, and required control interface. See Symbols and Placement of Valves diagram.

Consult factory before ordering any special valve package components that are not covered in this book.

Valve packages are shipped with the units or in unit cartons. Valve packages include belled ends for field soldering to coil connections.

All factory-furnished cooling valve packages are arranged to position as much of the package as possible over an auxiliary drain pan or drip lip. This helps minimize field piping insulation requirements.

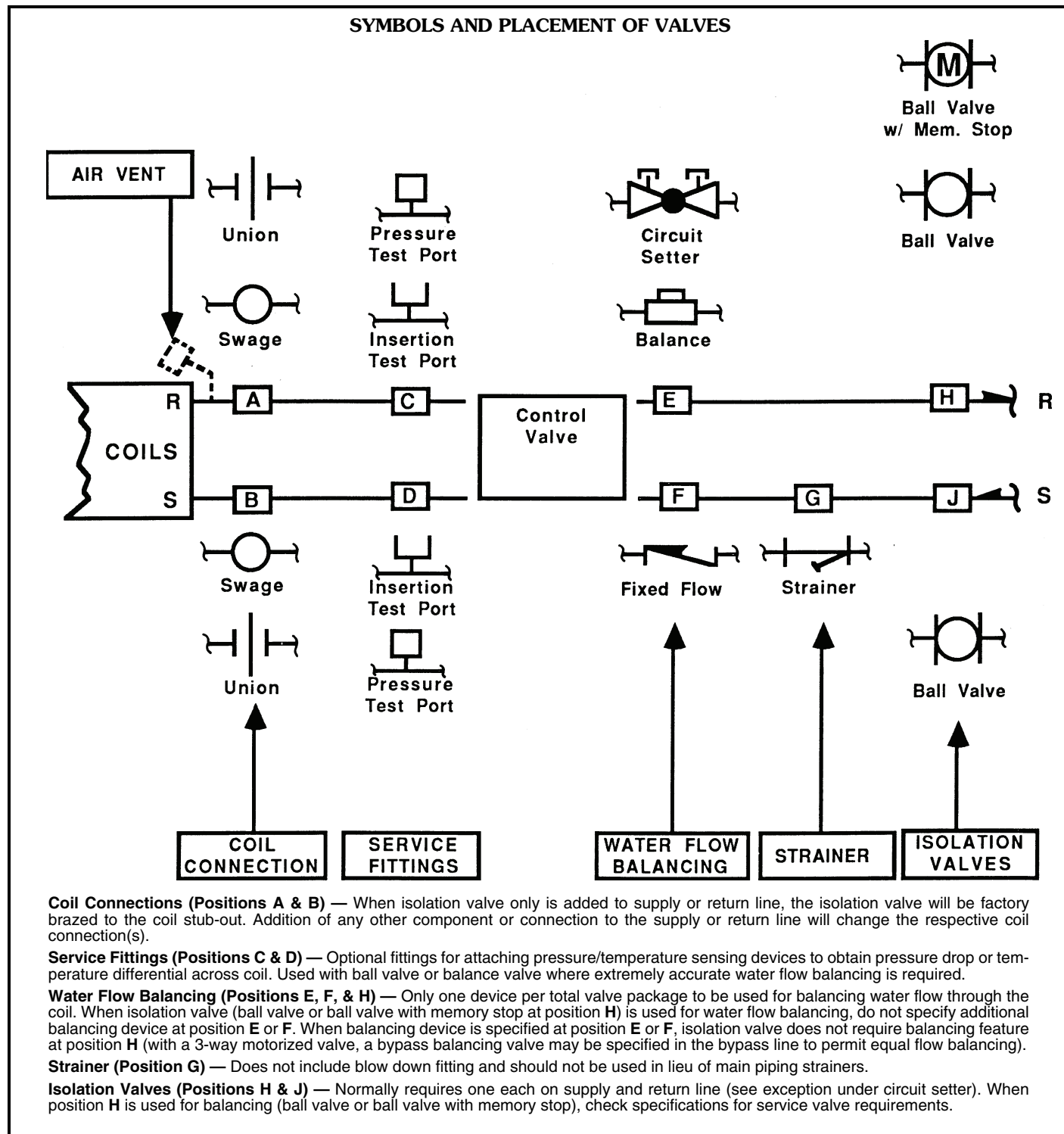

## VALVE PACKAGE SPACING RECOMMENDATIONS

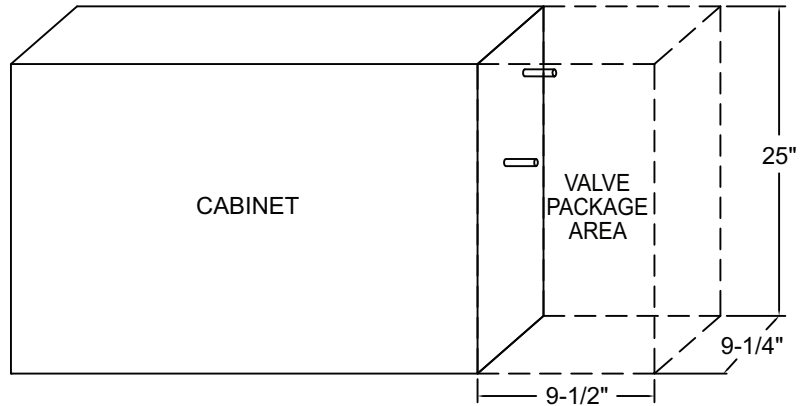

**42VAA (SEE NOTE 3)**

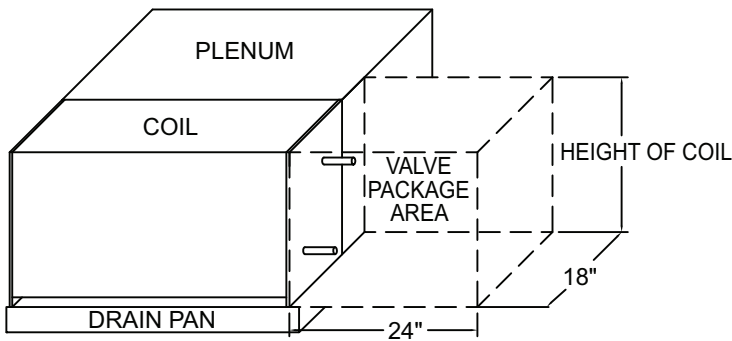

**42CEA, DCA (SEE NOTES 1, 2)**

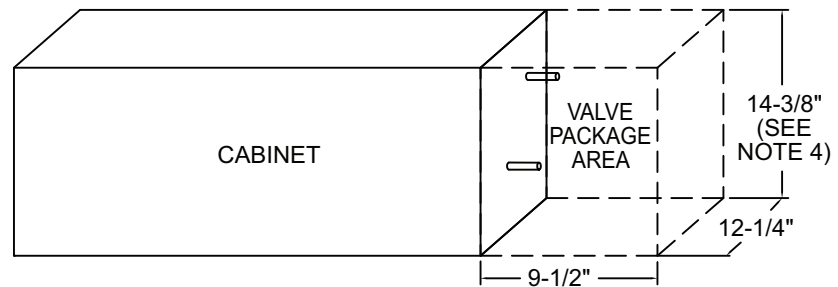

**42VCA (SEE NOTES 3, 4)**

**NOTES:**

1. Valve package dimensions on ceiling models are based on a 4-pipe unit with (1) 3-way control valve, (1) ball valve, and (1) circuit setter.
2. Coil height dimensions on 42CEA and 42DCA are provided in the physical data section of the product data.
3. Valve package dimensions on floor units are based on the valve package space provided on the exposed floor models.
4. Height of the 42VCA is  $16 \frac{3}{8}$  in. depending on coil and electric heat selection.

### C<sub>v</sub> FACTOR VS WATER PRESSURE DROP

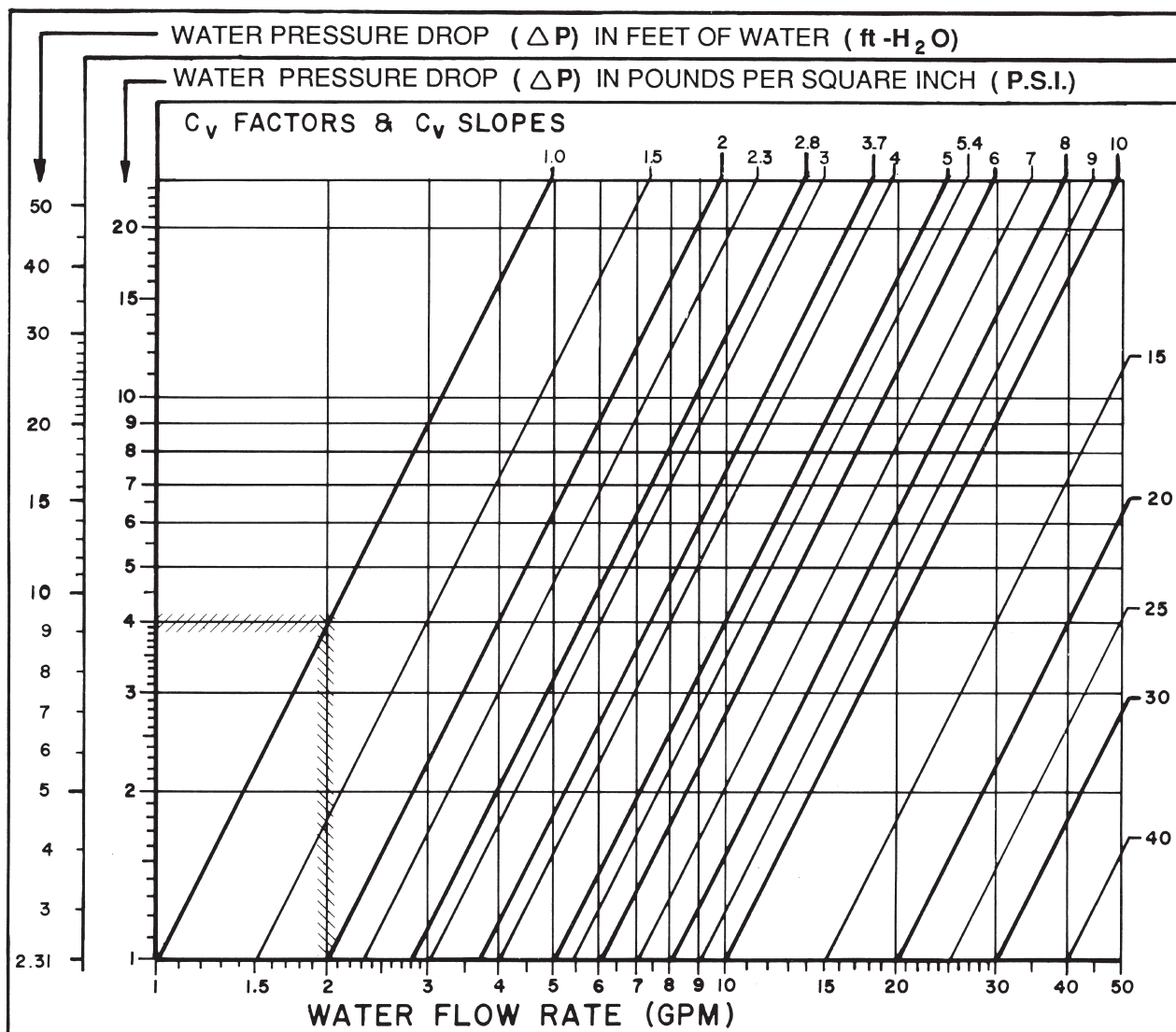

**C<sub>v</sub> FACTOR:**

The flow rate in gallons per minute (gpm) through a piping component when the pressure drop (ΔP) in pounds per square inch (psi) across the component is 1.0 (psi).

$$\text{Pressure drop (ft-H}_2\text{O)} = 2.31 \times \text{psi (pressure drop)}$$

**GRAPH EXAMPLE:**

ΔP for 2.0 gpm through a component with a C<sub>v</sub> of 1.0 is 4.0 psi x 2.31 = 9.24 ft-H<sub>2</sub>O

**FORMULA EXAMPLE:**

$$\Delta P \text{ (ft-H}_2\text{O)} = \frac{(\text{gpm})^2}{(\text{C}_v)^2} \times 2.31 = \frac{(2.0)^2}{(1.0)^2} \times 2.31 = 9.24 \text{ ft-H}_2\text{O}$$

**TOTAL PRESSURE DROP** is the **Sum** of the pressure drop of all piping and components in the water flow path.

# Application data (cont)



## ENTHALPY AT SATURATION

TEMPERATURE (F)	ENTHALPY AT SATURATION (Btu per lb of dry air)
40	15.230
41	15.697
42	16.172
43	16.657
44	17.149
45	17.650
46	18.161
47	18.680
48	19.211
49	19.751
50	20.301
51	20.862
52	21.436
53	22.020
54	22.615
55	23.22
56	23.84
57	24.48
58	25.12
59	25.78

TEMPERATURE (F)	ENTHALPY AT SATURATION (Btu per lb of dry air)
60	26.46
61	27.15
62	27.85
63	28.57
64	29.31
65	30.06
66	30.83
67	31.62
68	32.42
69	33.25
70	34.09
71	34.95
72	35.83
73	36.74
74	37.66
75	38.61
76	39.57
77	40.57
78	41.58
79	42.62
80	43.69

## ALTITUDE COOLING CORRECTION FACTORS

ELEVATION (ft)	TOTAL HEAT	SENSIBLE HEAT
Sea Level	1.00	1.00
1000	.990	.960
2000	.980	.930
3000	.970	.896
4000	.960	.864
5000	.940	.830
6000	.930	.800
7000	.920	.770
8000	.910	.750
9000	.900	.730

## AIRFLOW CORRECTION FACTORS

CFM RATIO (Actual/Base)	TOTAL (Ct)	SENSIBLE (Cs)
1.40	1.25	1.26
1.35	1.22	1.23
1.30	1.19	1.20
1.25	1.16	1.17
1.20	1.13	1.14
1.15	1.10	1.11
1.10	1.07	1.08
1.05	1.04	1.04
1.00	1.00	1.00
0.95	0.97	0.97
0.90	0.94	0.93
0.85	0.90	0.89
0.80	0.86	0.85
0.75	0.82	0.81
0.70	0.78	0.77
0.65	0.74	0.72
0.60	0.70	0.67
0.55	0.66	0.62
0.50	0.62	0.57
0.45	0.58	0.52
0.40	0.53	0.47
0.35	0.48	0.42
0.30	0.43	0.38
0.25	0.38	0.33

### LEGEND

- CFM — Cubic Feet per Minute
- Cs — Sensible Airflow Correction Factor
- Ct — Total Airflow Correction Factor

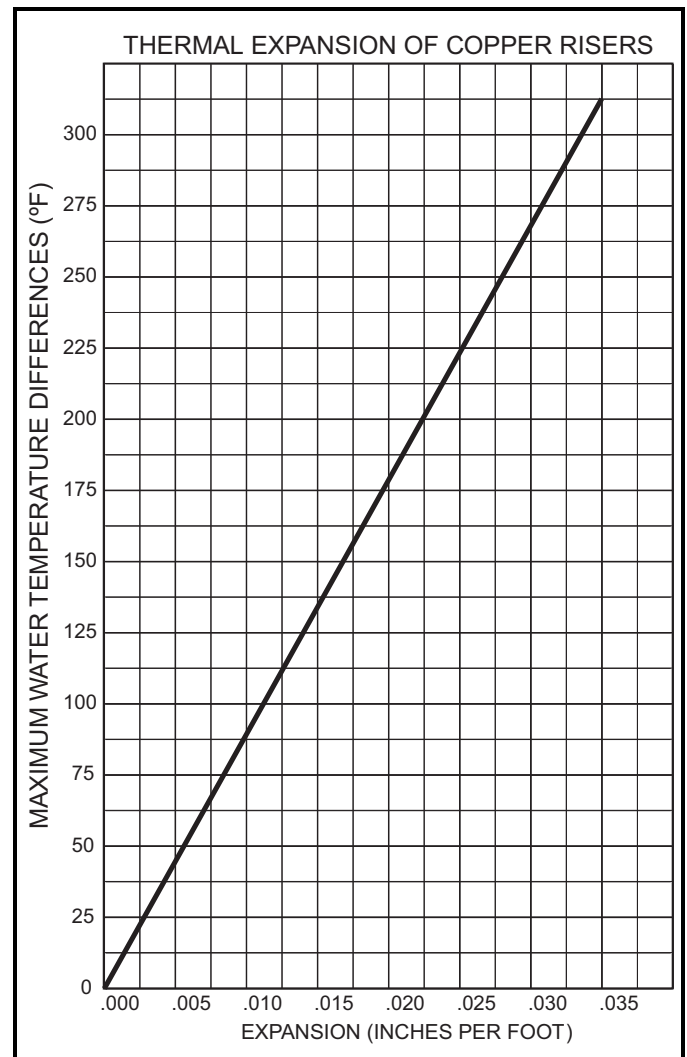

## Electric heat

Electric heaters are available for installation on Carrier fan coil units in the following applications.

**Total electric heat** — This system provides complete heating during the heating season; no boiler is required. Heating and cooling are now available on an individual basis throughout the year with a 2-pipe system.

Chilled water is used for cooling and the electric heater is used for heating. Individual room controls can be supplied for either manual or automatic changeover.

**Auxiliary electric heat** — This system is used for heating between seasons or during the cooling season when chilled water is being circulated. Individual room controls are supplied to provide electric heat only when chilled water is being circulated through the system. Water flow through the unit is shut off when the heater is turned on.

During the winter heating season, heating is provided by hot water circulated through the system. A changeover device locks out the electric heat when the hot water is circulated.

## Heater construction

**Strip heaters** are used with Model 42C ceiling units, Model 42D ducted units, Model 42S stack units and Model 42V (except 42VCA and VEA).

These heaters consist of coils of high grade resistance wire, insulated by ceramic insulators on plated steel brackets. High limit thermal cutouts protect the unit in the event of airflow loss.

All heaters except those used in 42S stack units are positioned on the incoming (preheat) side of the unit coil. On 42S stack units, the strip heater is located in the fan discharge on the leaving side of the coil.

**Sheath heaters** are used with Model 42VCA and 42VEA vertical units. These heaters consist of high grade resistance wire, centered in a 1/2 in. diameter copper plated steel sheath. The wire is insulated from the sheath by magnesium oxide powder packed around it. To increase the heater surface exposed to air, a 1 1/4 in. OD fin of copper plated steel is wound around the sheath in a spiral that makes 5 turns per linear inch. Sheath and fin are permanently bound together by copper brazing. The heaters are positioned on the leaving (reheat) side of the unit coil.

## Heater electrical data

1. Load voltage may be 120, 208, 240 or 277 volts. For unit size and kW limitations, refer to the specific unit catalogs.
2. All heaters are single stage and single phase except for 42SM, which offers 2-stage electric heaters.
3. Unless a single power-source option is selected, the electric heat units require 2 separate power sources. With the single power-source option, only one line circuit need be brought into the unit. Fuse protection is added to the motor/control circuit to protect these components. This is separate from the field-furnished total unit overcurrent protection.

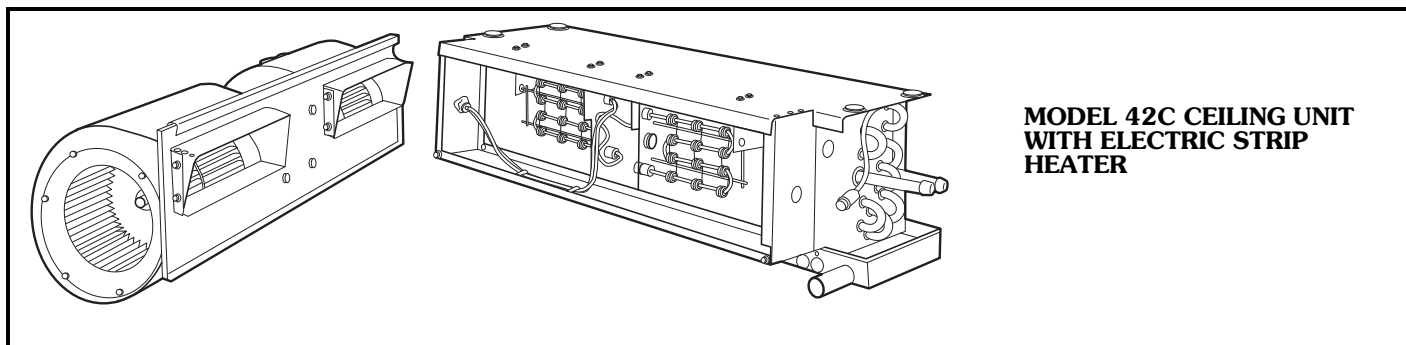

**MODEL 42C CEILING UNIT  
WITH ELECTRIC STRIP  
HEATER**

# Application data (cont)



## HEATER ELECTRICAL DATA

### 42C SERIES

HEATER VOLTAGE	kW	CAPACITY (Btuh)	UNIT SIZE							
			02	03	04	06	08	10	12	
120	0.5	1,708	*	*						
	1.0	3,415	*	*	*	*	*			
	1.5	5,123	*	*	*	*	*			
	2.0	6,830	*	*	*	*	*	*	*	
	3.0	10,245	*	*	*	*	*	*	*	*
208	0.5	1,708	*	*						
	1.0	3,415	*	*	*	*	*			
	1.5	5,123	*	*	*	*	*			
	2.0	6,830	*	*	*	*	*	*	*	
	3.0	10,245		*	*	*	*	*	*	*
	4.0	13,660				*	*	*	*	*
	5.0	17,075				*	*	*	*	*
	6.0	20,490				*	*	*	*	*
8.0	27,320						*	*	*	
240,277	0.5	1,708	*	*						
	1.0	3,415	*	*	*	*	*			
	1.5	5,123	*	*	*	*	*			
	2.0	6,830	*	*	*	*	*	*	*	
	3.0	10,245		*	*	*	*	*	*	*
	4.0	13,660				*	*	*	*	*
	5.0	17,075				*	*	*	*	*
6.0	20,490				*	*	*	*	*	
8.0	27,320						*	*	*	
10.0	34,150							*	*	

### 42V SERIES

HEATER VOLTAGE	kW	CAPACITY (Btuh)	UNIT SIZE							
			02	03	04	05	06	08	10	12
120	1.0	3,415	*	*	*	*	*			
	1.5	5,123		*	*	*	*			
	2.0	6,830			*	*	*	*		
	3.0	10,245				*	*	*	*	*
208, 240	1.0	3,415	*	*	*	*	*			
	1.5	5,123		*	*	*	*			
	2.0	6,830			*	*	*	*		
	3.0	10,245				*	*	*	*	*
4.0	13,660						*	*	*	
277	1.0	3,415	*	*	*	*	*			
	1.5	5,123		*	*	*	*			
	2.0	6,830			*	*	*	*		
	3.0	10,245				*	*	*	*	*
	4.0	13,660						*	*	*
	5.0	17,075							*	*
6.0	20,490								*	

NOTE: All heaters are single-stage and single-phase. Contact your Carrier representative for heater availability for 220-1-50 units.

### 42D SERIES

HEATER VOLTAGE	kW	CAPACITY (Btuh)	UNIT SIZE							
			06	08	10	12	14	16	18	20
120	2.0	6,830	*	*	*					
	3.0	10,245	*	*	*					
208, 240, 277	2.0	6,830	*	*	*					
	3.0	10,245	*	*	*					
	4.0	13,660	*	*	*	*	*	*	*	*
	5.0	17,075		*	*	*	*	*	*	*
	6.0	20,490		*	*	*	*	*	*	*
	7.0	23,905			*	*	*	*	*	*
	8.0	27,320				*	*	*	*	*
	9.0	30,735					*	*	*	*
	10.0	34,150						*	*	*
	12.0	40,980							*	*
	14.0	47,810								*

NOTE: All heaters are single-stage and single-phase.

### 42S SERIES

HEATER VOLTAGE	kW	UNIT SIZE								
		03	04	06	08	10	12	14	16	20
120	1.0	*	*	*	*	*	*			
	1.5	*	*	*	*	*	*			
	2.0	*	*	*	*	*	*			
	3.0	*	*	*	*	*	*			
208	1.0	*	*	*	*	*	*			
	1.5	*	*	*	*	*	*			
	2.0	*	*	*	*	*	*			
	3.0	*	*	*	*	*	*			
	4.0		*	*	*	*	*	*	*	*
	5.0			*	*	*	*			
	6.0			*	*	*	*	*	*	*
8.0				*	*	*	*	*	*	
240	1.0	*	*	*	*	*	*			
	1.5	*	*	*	*	*	*			
	2.0	*	*	*	*	*	*			
	3.0	*	*	*	*	*	*			
	4.0		*	*	*	*	*	*	*	*
	5.0			*	*	*	*			
	6.0			*	*	*	*	*	*	*
8.0				*	*	*	*	*	*	
10.0					*	*	*	*	*	
277	1.0	*	*	*	*	*	*			
	1.5	*	*	*	*	*	*			
	2.0	*	*	*	*	*	*			
	3.0	*	*	*	*	*	*			
	4.0		*	*	*	*	*	*	*	*
	5.0			*	*	*	*			
	6.0			*	*	*	*	*	*	*
	8.0				*	*	*	*	*	*
	10.0					*	*	*	*	*
	12.0							*	*	*

#### NOTES:

- Contact your Carrier representative for heater availability on 42SU unit quick ship program.
- 12 kW heater only available with 277V heater voltage.



## ECM motor control methods

There are three main control methods to control the speed of electronically commutated motor (ECM) for desirable air-flow for a given application.

**3-discrete speed input, potentiometer field speed adjustment** — This method uses the ECM with potentiometer field adjustment. The relay board will have three main circuits for HI, MEDIUM, and LOW speed. Each of these speeds can be adjusted by potentiometer to any value in the motor's operating range. This will allow the customization of air flow on each speed of the fan coil unit to better suit any requirements.

**4-discrete speed input, potentiometer field speed adjustment, solid state (only with 24-v controls by other option)** — This is the same as 3-discrete speed input but with additional fourth speed. All 4 speeds can be adjusted by potentiometer to any value in the motor's operating range.

**Control method no. 3 — ECM variable speed (only with 24-v controls by other option)** — This method requires 0 to 10-v signal for fan speed. It has no predetermined fan speeds and will ramp the motor fan speed according to the controller used on the fan coil unit. All ECM motor packages use a constant torque operating mode. An ETO request is required for pricing and availability of constant airflow operation.

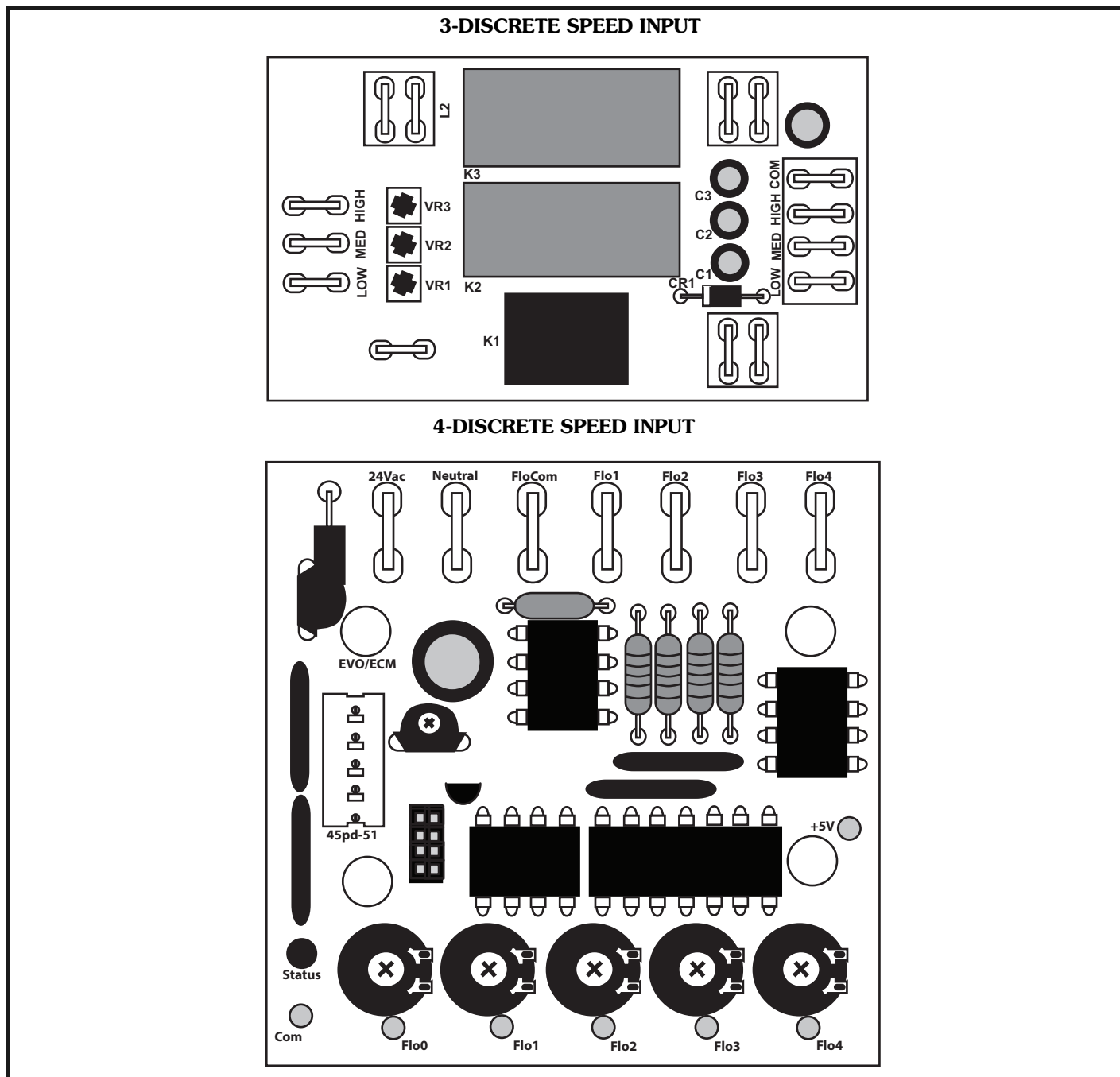

# Model number nomenclature



**42C Series Units**

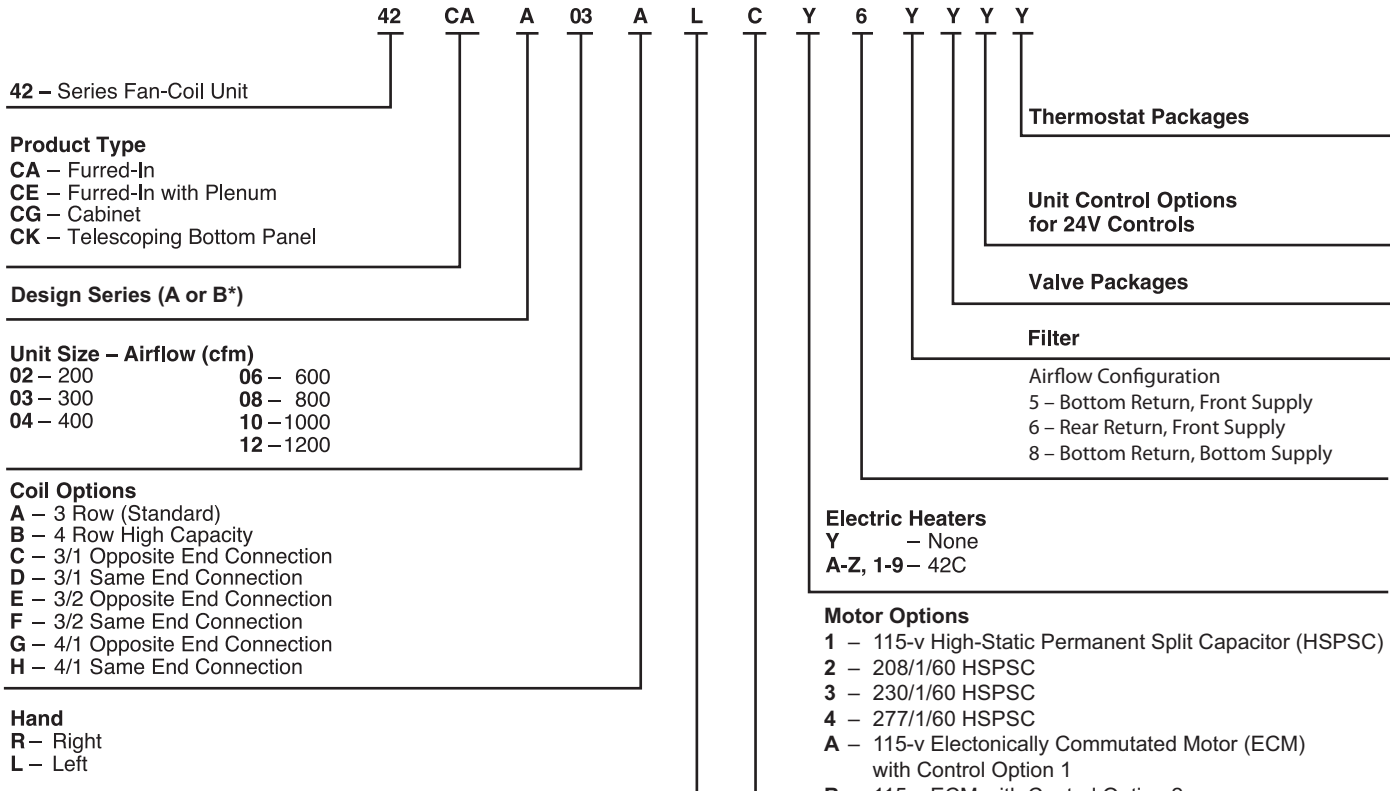

\* Model 42CG only.  
 † Contact Application Engineering for data on the 50 Hz motor.

- Motor Options**
- 1** – 115-v High-Static Permanent Split Capacitor (HSPSC)
  - 2** – 208/1/60 HSPSC
  - 3** – 230/1/60 HSPSC
  - 4** – 277/1/60 HSPSC
  - A** – 115-v Electronically Commutated Motor (ECM) with Control Option 1
  - B** – 115-v ECM with Control Option 2
  - C** – 115-v Permanent Split Capacitor (PSC) (Standard)
  - D** – 208/1/60 PSC
  - E** – 230/1/60 PSC
  - F** – 277/1/60 PSC
  - G** – 115-v ECM with Control Option 3
  - H** – 208-v ECM with Control Option 1
  - J** – 208-v ECM with Control Option 2
  - K** – 208-v ECM with Control Option 3
  - L** – 230-v ECM with Control Option 1
  - M** – 230-v ECM with Control Option 2
  - N** – 230-v ECM with Control Option 3
  - P** – 277-v ECM with Control Option 1
  - Q** – 277-v ECM with Control Option 3
  - R** – 277-v ECM with Control Option 2
  - V** – 220/1/50 PSC†
- Control Option 1 – 3-Discrete Potentiometer  
 Field Speed Adjustment
- Control Option 2 – Variable Flow 0-10 VDC  
 or 4-20 mA
- Control Option 3 – 4-Discrete Potentiometer  
 Field Speed Adjustment

# AHRI capacity ratings



The 42C Series fan coil units are certified in compliance with the Air-Conditioning, Heating and Refrigeration Institute (AHRI) Industry Standard 440 for room fan coil units. Approved standard ratings are tabulated below.



42C Series Units

## AHRI APPROVED STANDARD RATINGS\*

UNIT	UNIT SIZE	COIL ROWS	NOMINAL CFM	COOLING CAPACITY		POWER INPUT (WATTS)†
				Total MBtuh	Sensible MBtuh	
42CA,CE,CG,CK	02	3	200	6.0	4.4	87
	03		300	9.0	6.3	85
	04		400	12.1	8.8	165
	06		600	17.3	13.0	225
	08		800	22.6	16.2	235
	10		1000	27.5	21.0	305
	12		1200	32.8	25.0	435
	02	4	200	6.9	4.3	87
	03		300	9.8	6.5	85
	04		400	13.8	9.8	145
	06		600	19.6	14.3	220
	08		800	25.5	18.8	235
	10		1000	31.0	22.0	300
	12		1200	37.2	27.7	425

### LEGEND

**MBtuh** — Capacity (Btuh in thousands)

\*Ratings based on motor at high fan speed, standard air and dry coil operation, 10° F water temperature rise; entering-air temperature 67 F wb; 80 F db; entering water temperature 45 F.

†Motor type permanent split capacitor operating at 115-1-60 voltage.

# Physical data



**42C Series Units**

UNIT SIZE 42C	02	03	04	06	08	10	12
<b>NOMINAL AIRFLOW (cfm)</b>	200	300	400	600	800	1000	1200
<b>SHIPPING WEIGHT (lb)*</b>							
42CA	36	39	49	59	64	95	107
42CE	55	60	70	82	95	135	154
42CG	98	118	126	168	176	215	245
42CK	115	120	135	150	155	227	241
<b>COIL WATER WEIGHT (Approx lb per row of coil)</b>							
42CA, CE, CG, CK	0.7	0.8	1.0	1.4	1.7	2.3	2.7
<b>COILS</b>							
FPI				10 fins/inch			
Coil Face Area (sq ft)	0.8	1.1	1.4	1.9	2.3	3.2	3.7
<b>MOTOR (qty)</b>							
42C Series	1	1	1	1	1	2	2
<b>BLOWER (qty)</b>							
42CA, CE, CG, CK	1	1	2	2	2	4	4
<b>FILTERS</b>							
Nominal Size (in.) (1-in. thick)							
42CA	NA	NA	NA	NA	NA	NA	NA
42CE†	10 x 18	10 x 22	10 x 28	10 x 33	10 x 40	10 x 54	10 x 62
42CG							
Bottom Return	10 x 23 <sup>1</sup> / <sub>2</sub>	10 x 28	10 x 32 <sup>1</sup> / <sub>2</sub>	10 x 37	10 x 41	10 x 54 <sup>1</sup> / <sub>2</sub>	10 x 63
Rear Return	8 x 23 <sup>1</sup> / <sub>2</sub>	8 x 28	8 x 32 <sup>1</sup> / <sub>2</sub>	8 x 37	8 x 41	8 x 54 <sup>1</sup> / <sub>2</sub>	8 x 63
42CK							
Bottom Return	10 x 28	10 x 28	10 x 33	10 x 45	10 x 45	10 x 62	10 x 62
Rear Return	7 x 21	7 x 21	7 x 27	7 x 38	7 x 38	7 x 52	7 x 52
Qty	1	1	1	1	1	1	1
<b>SUPPLY DUCT COLLAR</b>	1-in.						
<b>PIPING CONNECTIONS (Sweat) (in.)</b>							
Drain Connection	7/8 OD						
Tell-Tale Drain	5/8 OD						

\*Calculate operating weight of unit: shipping weight + coil water weight x number of coil rows. Electric heating coils add 2 lb.  
 †Filter size if located in return-air plenum.

# Base unit dimensions

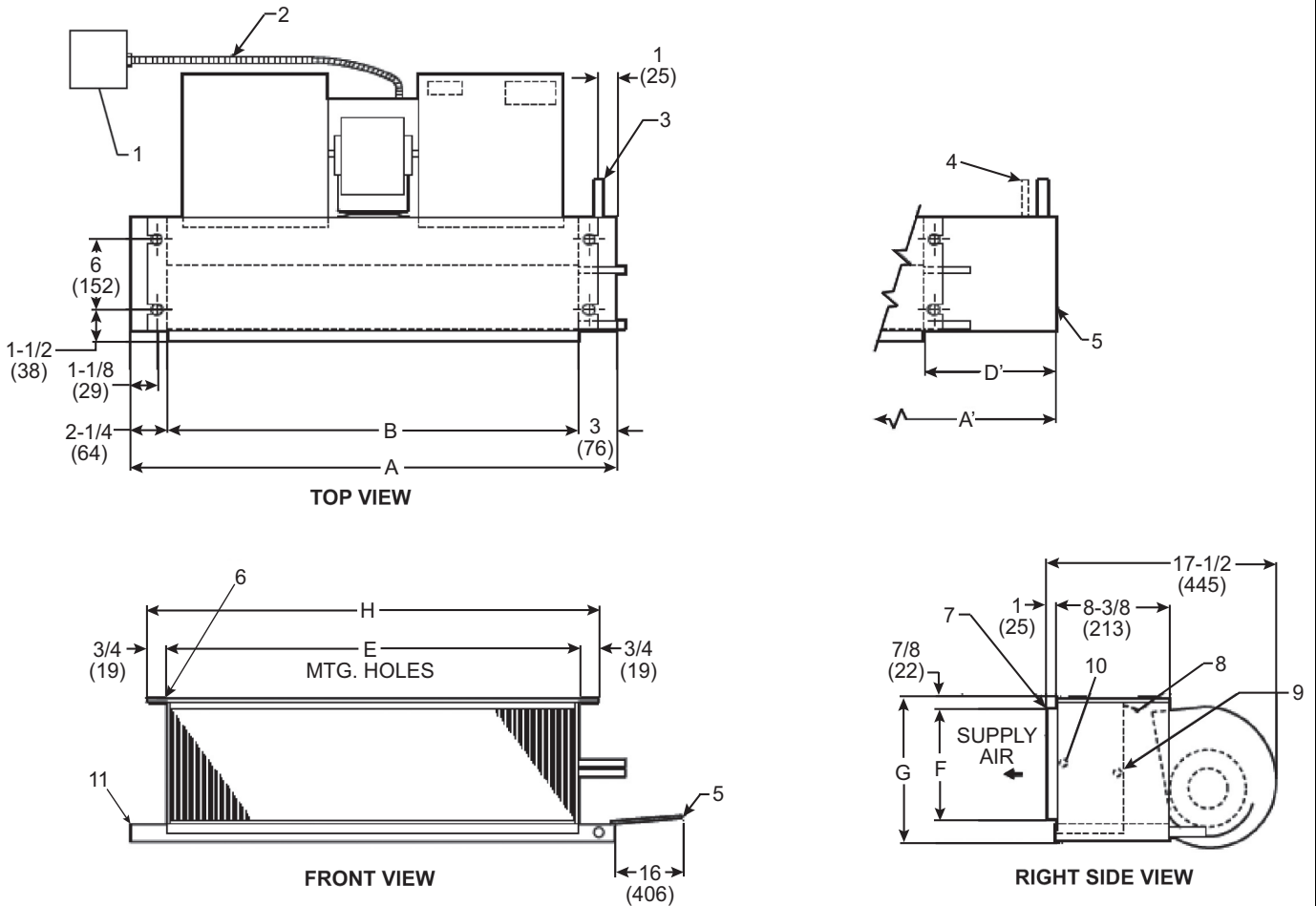
## 42CA FURRED-IN HORIZONTAL UNIT



- LEGEND**
- 1 — Junction Box (remote mount)
  - 2 — Flexible Metal Conduit
  - 3 — Drain Conn, 7/8-in. OD
  - 4 — Tell-Tale Drain Conn, 5/8-in. OD (optional)
  - 5 — Drip Lip (optional)
  - 6 — Hanger Slots (4), Rubber Grommet has 3/8-in. Diameter Hole
  - 7 — Supply Duct Collar, 1-in.
  - 8 — Air Vent, 1/8-in. MPT
  - 9 — Return Conn
  - 10 — Supply Conn
  - 11 — Drain Pan

- NOTES:**
1. Right hand unit shown; left hand unit opposite. Coil connection locations are  $\pm 5/8$ -inches.
  2. Unit sizes 02 and 03 have one motor, one blower; sizes 04 through 08 have one motor, 2 blowers; sizes 10 and 12 have 2 motors, 4 blowers.
  3. Standard 3-row coil shown.
  4. Overall unit dimension increases by 4 in. with optional electric heat.
  5. Not shown: 3-speed fan switch; wall plate, closed cell foam on main drain pan.
  6. Units have galvanized finish.
  7. See 42CA-203-1 for optional coil connections.
  8. Dimensions shown in inches (mm).

UNIT SIZE	NOM AIRFLOW (Cfm)	DIMENSIONS (in.)								QTY/UNIT		FACE AREA (sq ft)	UNIT WEIGHT* (lb)
		A	A'	B	D'	E	F	G	H	Blower	Motor		
02	200	21 1/4	31 1/4	16	13	18 1/4	6 1/4	8 3/4	19 3/4	1	1	0.83	36
03	300	25 1/4	36 1/4	20	14	22 1/4	6 1/4	8 3/4	23 3/4	1	1	1.08	39
04	400	31 1/4	43 1/4	26	15	28 1/4	6 1/4	8 3/4	29 3/4	2	1	1.35	49
06	600	36 1/4	43 1/4	31	10	33 1/4	7 1/2	10	34 3/4	2	1	1.88	59
08	800	43 1/4	57 1/4	38	17	40 1/4	7 1/2	10	41 3/4	2	1	2.31	64
10	1000	57 1/4	65 1/4	52	11	54 1/4	7 1/2	10	55 3/4	4	2	3.16	95
12	1200	65 1/4	75 1/4	60	13	62 1/4	7 1/2	10	63 3/4	4	2	3.65	107

\*Unit weights are based on dry coils and minimum rows. Weights exclude packaging, valves, and other components.

# Base unit dimensions (cont)

42C Series Units

## 42CA FURRED-IN HORIZONTAL UNIT WITH ELECTRIC HEAT

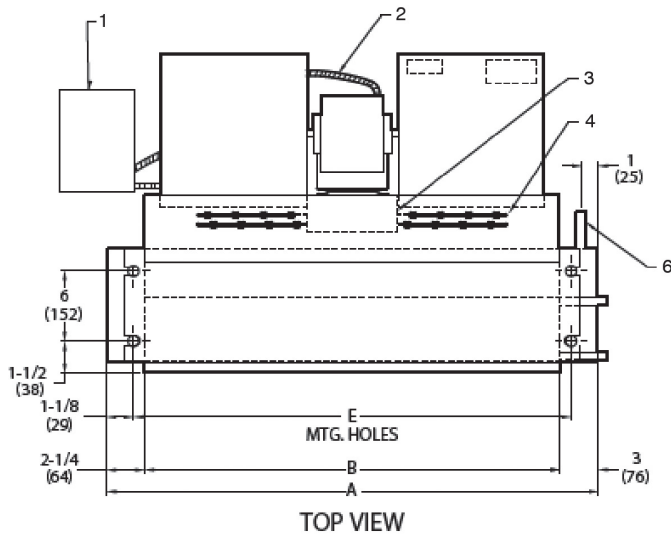

TOP VIEW

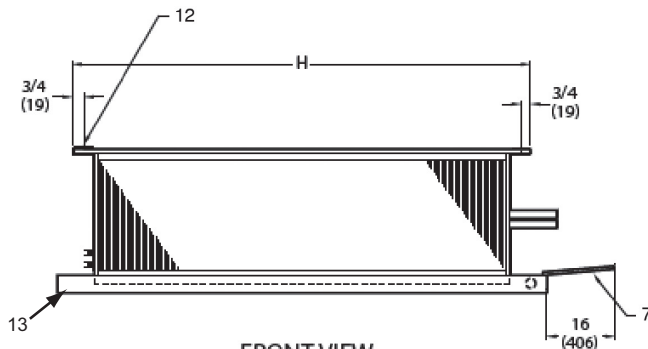
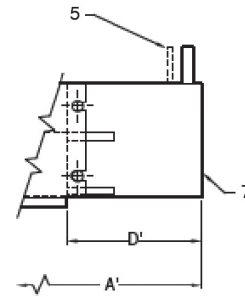

FRONT VIEW

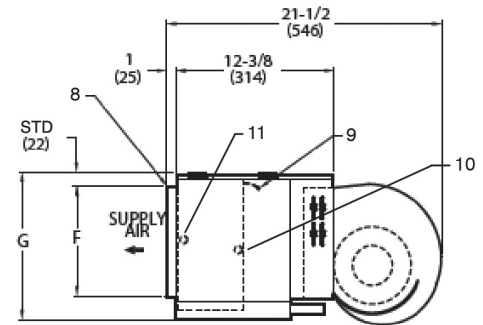

RIGHT SIDE VIEW

**LEGEND**

- 1 — Junction Box (remote mount)
- 2 — Flexible Metal Conduit
- 3 — Strip Heater High Limit
- 4 — Electric Strip Heater Element
- 5 — Tell-Tale Drain Conn, 5/8-in. OD (optional)
- 6 — Drain Conn, 7/8-in. OD
- 7 — Drip Lip (optional)
- 8 — Supply Duct Collar, 1-in.
- 9 — Air Vent, 1/8-in. MPT
- 10 — Return Conn
- 11 — Supply Conn
- 12 — Hanger Slots (4), Rubber Grommet has 3/8-in. Diameter Hole
- 13 — Drain Pan

**NOTES:**

- 1. Right hand unit shown; left hand unit opposite. Coil connection locations are  $\pm 5/8$ -inches.
- 2. Unit sizes 02 and 03 have one motor, one blower; sizes 04 through 08 have one motor, 2 blowers; sizes 10 and 12 have 2 motors, 4 blowers.
- 3. Standard 3-row coil shown.
- 4. Overall unit dimension increases by 4 in. with optional electric heat.
- 5. Not shown: 3-speed fan switch; wall plate, closed cell foam on main drain pan.
- 6. Units have galvanized finish.
- 7. See 42CA-203-1 for optional coil connections.
- 8. Dimensions shown in inches (mm).

UNIT SIZE	NOM AIRFLOW (Cfm)	DIMENSIONS (in.)								QTY/UNIT		FACE AREA (sq ft)	UNIT WEIGHT* (lb)
		A	A'	B	D'	E	F	G	H	Blower	Motor		
02	200	21 <sup>1</sup> / <sub>4</sub>	31 <sup>1</sup> / <sub>4</sub>	16	13	18 <sup>1</sup> / <sub>4</sub>	6 <sup>1</sup> / <sub>4</sub>	8 <sup>3</sup> / <sub>4</sub>	19 <sup>3</sup> / <sub>4</sub>	1	1	0.83	38
03	300	25 <sup>1</sup> / <sub>4</sub>	36 <sup>1</sup> / <sub>4</sub>	20	14	22 <sup>1</sup> / <sub>4</sub>	6 <sup>1</sup> / <sub>4</sub>	8 <sup>3</sup> / <sub>4</sub>	23 <sup>3</sup> / <sub>4</sub>	1	1	1.08	41
04	400	31 <sup>1</sup> / <sub>4</sub>	43 <sup>1</sup> / <sub>4</sub>	26	15	28 <sup>1</sup> / <sub>4</sub>	6 <sup>1</sup> / <sub>4</sub>	8 <sup>3</sup> / <sub>4</sub>	29 <sup>3</sup> / <sub>4</sub>	2	1	1.35	51
06	600	36 <sup>1</sup> / <sub>4</sub>	43 <sup>1</sup> / <sub>4</sub>	31	10	33 <sup>1</sup> / <sub>4</sub>	7 <sup>1</sup> / <sub>2</sub>	10	34 <sup>3</sup> / <sub>4</sub>	2	1	1.88	61
08	800	43 <sup>1</sup> / <sub>4</sub>	57 <sup>1</sup> / <sub>4</sub>	38	17	40 <sup>1</sup> / <sub>4</sub>	7 <sup>1</sup> / <sub>2</sub>	10	41 <sup>3</sup> / <sub>4</sub>	2	1	2.31	66
10	1000	57 <sup>1</sup> / <sub>4</sub>	65 <sup>1</sup> / <sub>4</sub>	52	11	54 <sup>1</sup> / <sub>4</sub>	7 <sup>1</sup> / <sub>2</sub>	10	55 <sup>3</sup> / <sub>4</sub>	4	2	3.16	97
12	1200	65 <sup>1</sup> / <sub>4</sub>	75 <sup>1</sup> / <sub>4</sub>	60	13	62 <sup>1</sup> / <sub>4</sub>	7 <sup>1</sup> / <sub>2</sub>	10	63 <sup>3</sup> / <sub>4</sub>	4	2	3.65	109

\*Unit weights are based on dry coils and minimum rows. Weights exclude packaging, valves, and other components.

**42CE FURRED-IN HORIZONTAL UNIT WITH PLENUM**

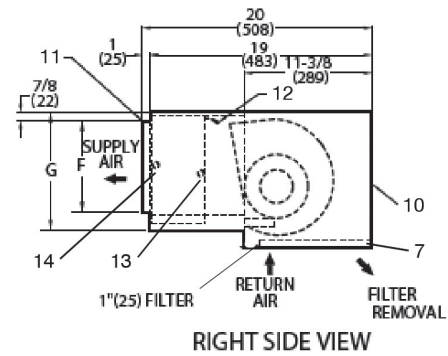
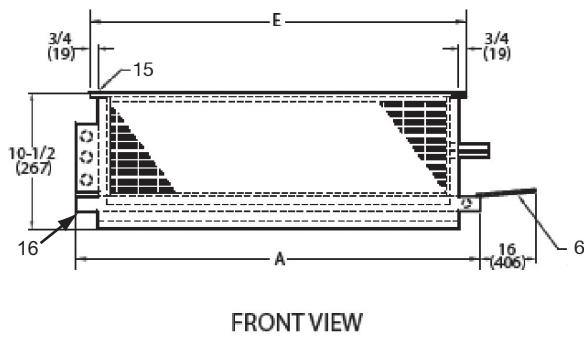
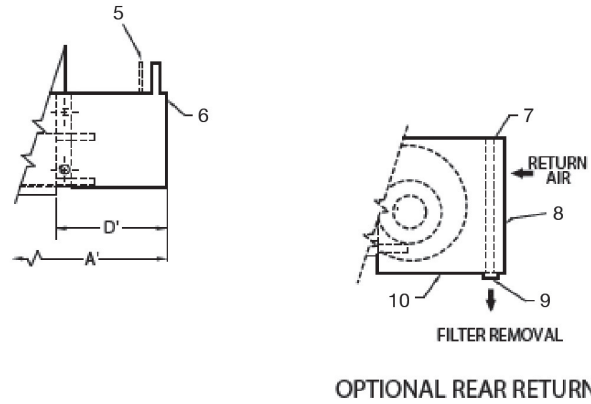
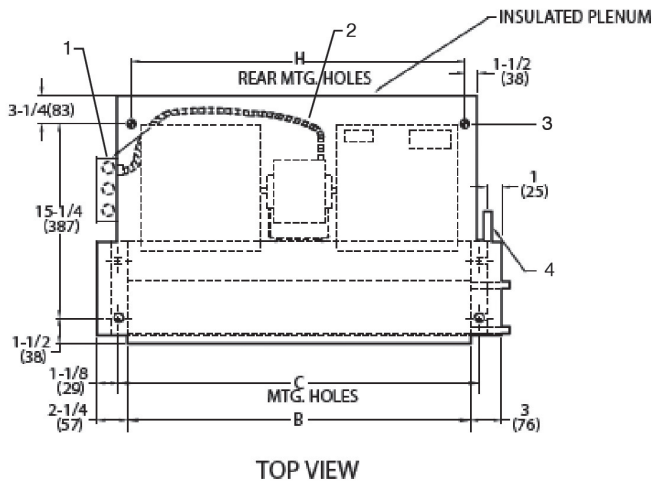

- LEGEND**
- 1 — Junction Box, 4 in. x 4 in.
  - 2 — Flexible Metal Conduit
  - 3 — Mounting Bracket
  - 4 — Drain Conn, 7/8-in. OD
  - 5 — Tell-Tale Drain Conn, 5/8-in. OD (optional)
  - 6 — Drip Lip (optional, shipped loose)
  - 7 — Filter
  - 8 — Return Duct Collar, 1-in.
  - 9 — Filter Access Panel
  - 10 — Access Panel
  - 11 — Supply Duct Collar, 1-in.
  - 12 — Air Vent, 1/8-in. MPT
  - 13 — Return Conn
  - 14 — Supply Conn
  - 15 — Hanger Slots (4), Rubber Grommet has 3/8-in. Diameter Hole
  - 16 — Drain Pan

- NOTES:**
1. Right hand unit with standard 3-row coil shown; left hand unit opposite. Coil connection locations are  $\pm 5/8$ -inches.
  2. Unit sizes 02 and 03 have one motor, one blower; sizes 04 through 08 have one motor, 2 blowers; sizes 10 and 12 have 2 motors, 4 blowers.
  3. Standard 3-row coil shown.
  4. Unit available with bottom or rear return air.
  5. Dimension increases by 4 in. with optional electric heat.
  6. Not shown: 3-speed fan switch; wall plate, 1/2-in. fiberglass insulation on inside of plenum, closed cell foam on main drain pan.
  7. Units have galvanized finish.
  8. See 42CA-203-1 for optional coil connections.
  9. Dimensions shown in inches (mm).

UNIT SIZE	NOM AIRFLOW (Cfm)	DIMENSIONS (in.)									QTY/UNIT		FACE AREA (sq ft)	UNIT WEIGHT* (lb)
		A	A'	B	C	D'	E	F	G	H	Blower	Motor		
02	200	21 <sup>1</sup> / <sub>4</sub>	31 <sup>1</sup> / <sub>4</sub>	16	18 <sup>3</sup> / <sub>4</sub>	13	19 <sup>3</sup> / <sub>4</sub>	6 <sup>1</sup> / <sub>4</sub>	8 <sup>3</sup> / <sub>4</sub>	15 <sup>3</sup> / <sub>8</sub>	1	1	0.83	55
03	300	25 <sup>1</sup> / <sub>4</sub>	36 <sup>1</sup> / <sub>4</sub>	20	22 <sup>1</sup> / <sub>4</sub>	14	23 <sup>3</sup> / <sub>4</sub>	6 <sup>1</sup> / <sub>4</sub>	8 <sup>3</sup> / <sub>4</sub>	19 <sup>3</sup> / <sub>8</sub>	1	1	1.08	60
04	400	31 <sup>1</sup> / <sub>4</sub>	43 <sup>1</sup> / <sub>4</sub>	26	28 <sup>1</sup> / <sub>4</sub>	15	29 <sup>3</sup> / <sub>4</sub>	6 <sup>1</sup> / <sub>4</sub>	8 <sup>3</sup> / <sub>4</sub>	25 <sup>3</sup> / <sub>8</sub>	2	1	1.35	70
06	600	36 <sup>1</sup> / <sub>4</sub>	43 <sup>1</sup> / <sub>4</sub>	31	33 <sup>1</sup> / <sub>4</sub>	10	34 <sup>3</sup> / <sub>4</sub>	7 <sup>1</sup> / <sub>2</sub>	10	30 <sup>3</sup> / <sub>8</sub>	2	1	1.88	82
08	800	43 <sup>1</sup> / <sub>4</sub>	57 <sup>1</sup> / <sub>4</sub>	38	40 <sup>1</sup> / <sub>4</sub>	17	41 <sup>3</sup> / <sub>4</sub>	7 <sup>1</sup> / <sub>2</sub>	10	37 <sup>3</sup> / <sub>8</sub>	2	1	2.31	95
10	1000	57 <sup>1</sup> / <sub>4</sub>	65 <sup>1</sup> / <sub>4</sub>	52	54 <sup>1</sup> / <sub>4</sub>	11	55 <sup>3</sup> / <sub>4</sub>	7 <sup>1</sup> / <sub>2</sub>	10	51 <sup>3</sup> / <sub>8</sub>	4	2	3.16	135
12	1200	65 <sup>1</sup> / <sub>4</sub>	75 <sup>1</sup> / <sub>4</sub>	60	62 <sup>1</sup> / <sub>4</sub>	13	63 <sup>3</sup> / <sub>4</sub>	7 <sup>1</sup> / <sub>2</sub>	10	59 <sup>3</sup> / <sub>8</sub>	4	2	3.65	154

\*Unit weights are based on dry coils and minimum rows. Weights exclude packaging, valves, and other components.

# Base unit dimensions (cont)

42C Series Units

## 42CE FURRED-IN HORIZONTAL UNIT WITH PLENUM AND ELECTRIC HEAT

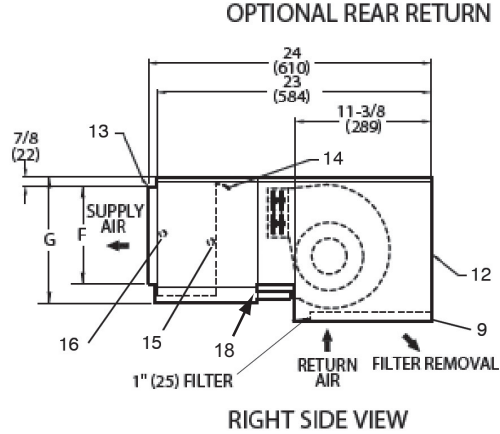
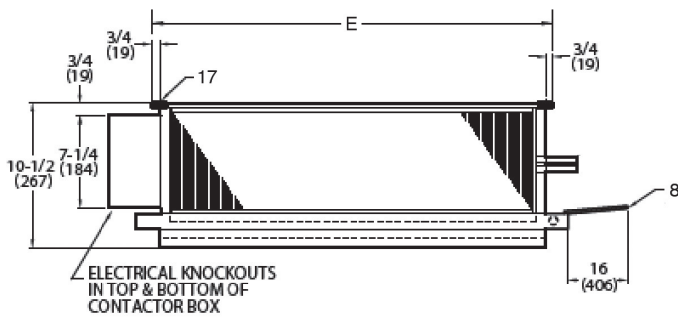
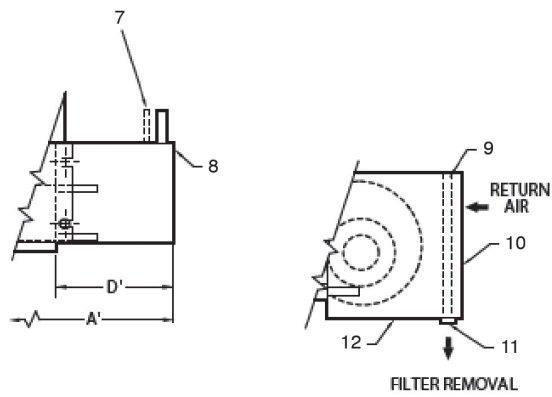
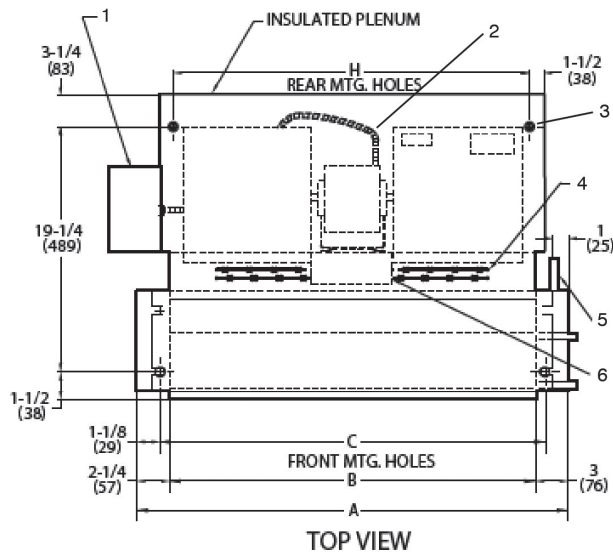

### LEGEND

- 1 — Junction Box, 4 in. x 4 in.
- 2 — Flexible Metal Conduit
- 3 — Mounting Bracket
- 4 — Electric Strip Heater Element
- 5 — Drain Conn, 7/8-in. OD
- 6 — Strip Heater High Limit
- 7 — Tell-Tale Drain Conn, 5/8-in. OD (optional)
- 8 — Drip Lip (optional, shipped loose)
- 9 — Filter
- 10 — Return Duct Collar, 1-in.
- 11 — Filter Access Panel
- 12 — Access Panel
- 13 — Supply Duct Collar, 1-in.
- 14 — Air Vent, 1/8-in. MPT
- 15 — Return Conn
- 16 — Supply Conn
- 17 — Hanger Slots (4), Rubber Grommet has 3/8-in. Diameter Hole
- 18 — Drain Pan

### NOTES:

- 1. Right hand unit with standard 3-row coil shown; left hand unit opposite. Coil connection locations are  $\pm 5/8$ -inches.
- 2. Unit sizes 02 and 03 have one motor, one blower; sizes 04 through 08 have one motor, 2 blowers; sizes 10 and 12 have 2 motors, 4 blowers.
- 3. Standard 3-row coil shown.
- 4. Unit available with bottom or rear return air.
- 5. Dimension increases by 4 in. with optional electric heat.
- 6. Not shown: 3-speed fan switch; wall plate, 1/2-in. fiberglass insulation on inside of plenum, closed cell foam on main drain pan.
- 7. Units have galvanized finish.
- 8. See 42CA-203-1 for optional coil connections.
- 9. Dimensions shown in inches (mm).

UNIT SIZE	NOM AIRFLOW (Cfm)	DIMENSIONS (in.)										QTY/UNIT		FACE AREA (sq ft)	UNIT WEIGHT* (lb)
		A	A'	B	C	D'	E	F	G	H	Blower	Motor			
02	200	21 1/4	31 1/4	16	18 1/4	13	19 3/4	6 1/4	8 3/4	15 3/8	1	1	0.83	57	
03	300	25 1/4	36 1/4	20	22 1/4	14	23 3/4	6 1/4	8 3/4	19 3/8	1	1	1.08	62	
04	400	31 1/4	43 1/4	26	28 1/4	15	29 3/4	6 1/4	8 3/4	25 3/8	2	1	1.35	72	
06	600	36 1/4	43 1/4	31	33 1/4	10	34 3/4	7 1/2	10	30 3/8	2	1	1.88	84	
08	800	43 1/4	57 1/4	38	40 1/4	17	41 3/4	7 1/2	10	37 3/8	2	1	2.31	97	
10	1000	57 1/4	65 1/4	52	54 1/4	11	55 3/4	7 1/2	10	51 3/8	4	2	3.16	137	
12	1200	65 1/4	75 1/4	60	62 1/4	13	63 3/4	7 1/2	10	59 3/8	4	2	3.65	156	

\*Unit weights are based on dry coils and minimum rows. Weights exclude packaging, valves, and other components.



### 42CG HORIZONTAL CABINET UNIT

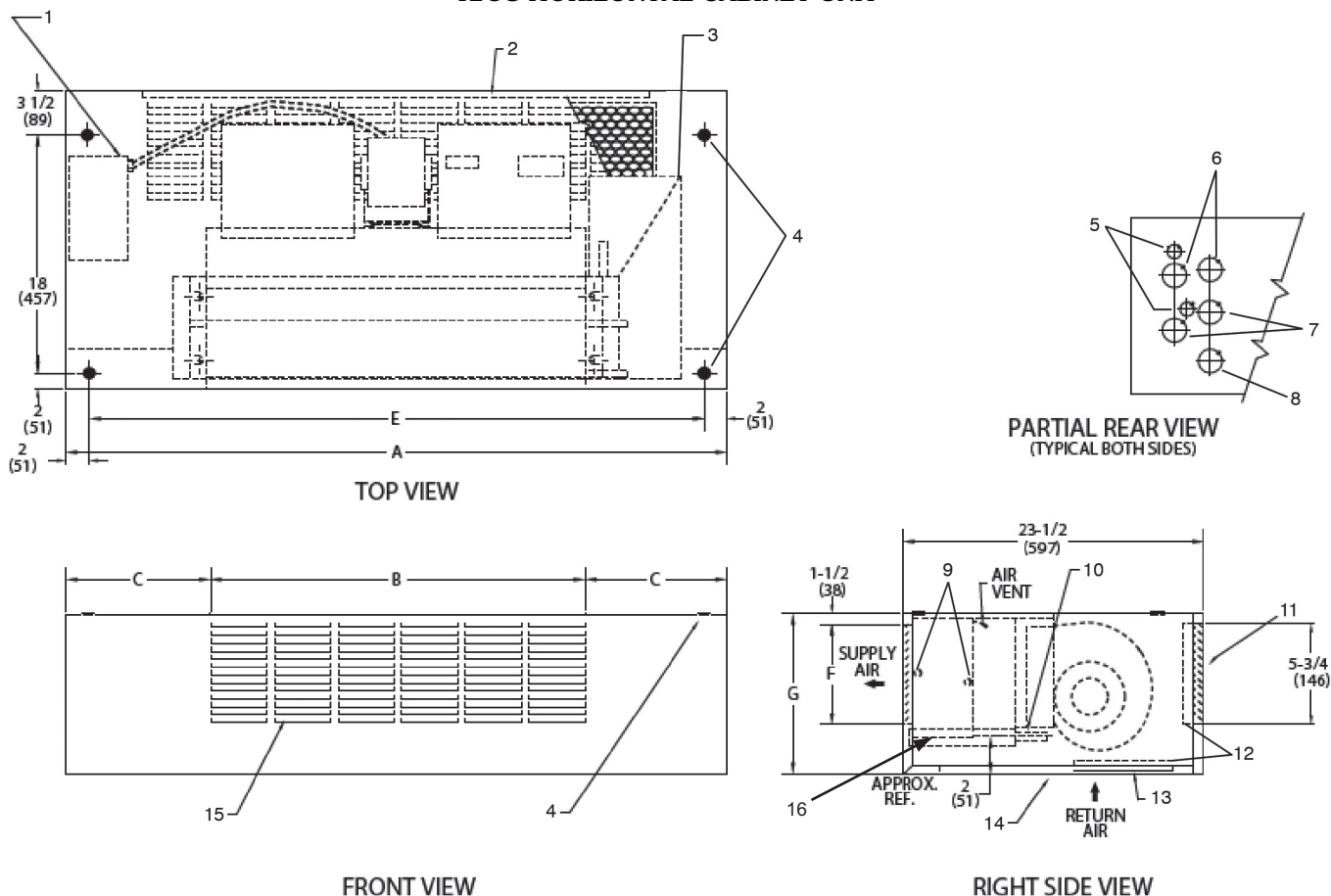

#### LEGEND

- 1 — Junction Box, 4 in. x 4 in.
- 2 — Optional Return Air Location
- 3 — Optional Drip Lip, shipped loose
- 4 — Mounting Holes (4), Rubber Grommets have 3/8-in. Diameter Hole
- 5 — Electrical Knockout, 7/8-in. Diameter
- 6 — Return Knockout, 1-in. Diameter
- 7 — Supply Knockout, 1 1/2-in. Diameter
- 8 — Drain Knockout, 1 1/2-in. Diameter
- 9 — Supply, Return Connections
- 10 — Drain Connection, 7/8-in. OD
- 11 — Optional Valve Package (inside cabinet)
- 12 — Filter
- 13 — Standard Stamped-Return Air Grille
- 14 — Removeable Hinged Access Panel
- 15 — Supply Grille, Stamped, Standard
- 16 — Drain Pan

#### NOTES:

- 1. Right hand unit shown; left hand unit opposite. Coil connection locations are  $\pm 5/8$ -inches.
- 2. Unit sizes 02 and 03 have one motor, one blower; sizes 04 through 08 have one motor, 2 blowers; sizes 10 and 12 have 2 motors, 4 blowers.
- 3. Cabinet has an Arctic White baked finish.
- 4. Refer to supply and return connections above for coil stub-out locations.
- 5. Not shown: optional drip lip, 3-speed fan switch; wall plate, 1/2-in. fiberglass insulation on inside of casing, closed cell foam on main drain pan.
- 6. See 42CA-203-1 for optional coil connections.
- 7. Valve package is factory-installed inside the cabinet when ordered with the unit (based on component size).
- 8. Dimensions shown in inches (mm).

UNIT SIZE	NOM AIRFLOW (Cfm)	DIMENSIONS (in.)						QTY/UNIT		FACE AREA (sq ft)	UNIT WEIGHT* (lb)
		A	B	C	E	F	G	Blower	Motor		
02	200	38	17 1/8	10 7/16	34	5 3/4	11	1	1	0.83	98
03	300	42	21 1/2	10 1/4	38	5 3/4	11	1	1	1.08	118
04	400	48	25 7/8	11 1/16	44	5 3/4	11	2	1	1.35	126
06	600	53	34 5/8	9 3/16	49	6 3/4	12	2	1	1.88	168
08	800	60	39	10 1/2	56	6 3/4	12	2	1	2.31	176
10	1000	74	52 1/8	10 15/16	70	6 3/4	12	4	2	3.16	215
12	1200	82	60 7/8	10 9/16	78	6 3/4	12	4	2	3.65	245

\*Unit weights are based on dry coils and minimum rows. Weights exclude packaging, valves, and other components.

# Base unit dimensions (cont)

42C Series Units

## 42CG HORIZONTAL CABINET WITH ELECTRIC HEAT

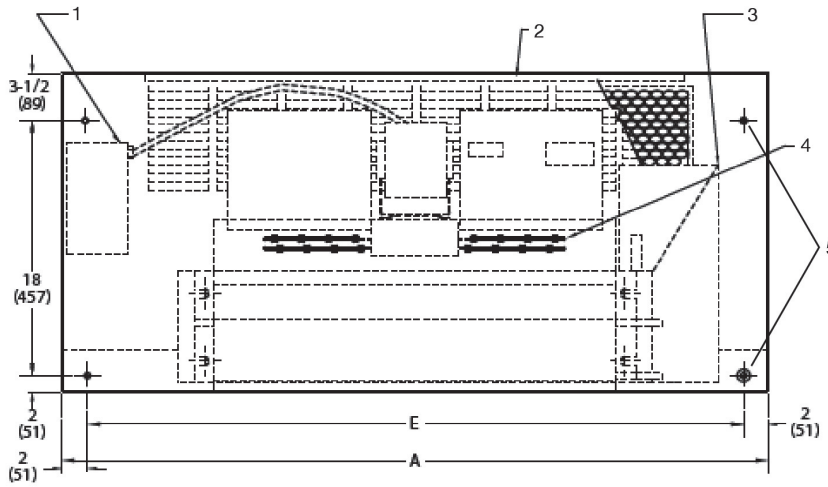

TOP VIEW

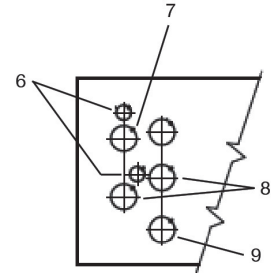

PARTIAL REAR VIEW  
(TYPICAL BOTH SIDES)

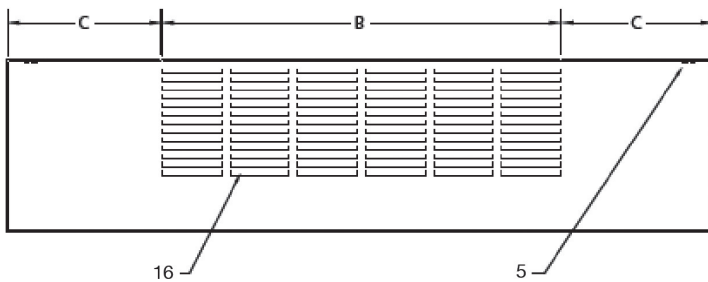

FRONT VIEW

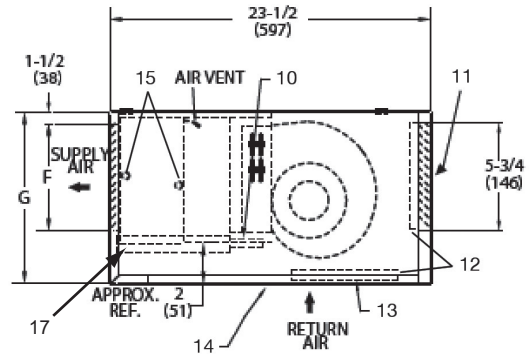

RIGHT SIDE VIEW

LEGEND

- 1 — Junction Box, 4 in. x 4 in.
- 2 — Optional Stamped Rear Return Grille
- 3 — Optional Drip Lip, shipped loose
- 4 — Electric Strip Heater Element
- 5 — Mounting Holes (4), Rubber Grommets have 3/8-in. Diameter Hole
- 6 — Electrical Knockout, 7/8-in. Diameter
- 7 — Return Knockout, 1-in. Diameter
- 8 — Supply Knockout, 1 1/2-in. Diameter
- 9 — Drain Knockout, 1 1/2-in. Diameter
- 10 — Drain Connection, 7/8-in. OD
- 11 — Optional Valve Package (inside cabinet)
- 12 — Filter
- 13 — Standard Stamped-Return Air Grille
- 14 — Removeable Hinged Access Panel
- 15 — Supply, Return Connections
- 16 — Supply Grille, Stamped, Standard
- 17 — Drain Pan

NOTES:

1. Right hand unit shown; left hand unit opposite. Coil connection locations are ±5/8-inches.
2. Unit sizes 02 and 03 have one motor, one blower; sizes 04 through 08 have one motor, 2 blowers; sizes 10 and 12 have 2 motors, 4 blowers.
3. Cabinet has an Arctic White baked finish.
4. Refer to supply and return connections above for coil stub-out locations.
5. Not shown: optional drip lip, 3-speed fan switch; wall plate, 1/2-in. fiberglass insulation on inside of casing, closed cell foam on main drain pan.
6. See 42CA-203-1 for optional coil connections.
7. Valve package is factory-installed inside the cabinet when ordered with the unit (based on component size).
8. Dimensions shown in inches (mm).

UNIT SIZE	NOM AIRFLOW (Cfm)	DIMENSIONS (in.)						QTY/UNIT		FACE AREA (sq ft)	UNIT WEIGHT* (lb)
		A	B	C	E	F	G	Blower	Motor		
02	200	38	17 1/8	10 7/16	34	5 3/4	11	1	1	0.83	98
03	300	42	21 1/2	10 1/4	38	5 3/4	11	1	1	1.08	118
04	400	48	25 7/8	11 1/16	44	5 3/4	11	2	1	1.35	126
06	600	53	34 5/8	9 3/16	49	6 3/4	12	2	1	1.88	168
08	800	60	39	10 1/2	56	6 3/4	12	2	1	2.31	176
10	1000	74	52 1/8	10 15/16	70	6 3/4	12	4	2	3.16	215
12	1200	82	60 7/8	10 9/16	78	6 3/4	12	4	2	3.65	245

\*Unit weights are based on dry coils and minimum rows. Weights exclude packaging, valves, and other components.

**42CG HORIZONTAL CABINET WITH DOUBLE DEFLECTOR SUPPLY AIR GRILLE AND DUCT REAR RETURN**

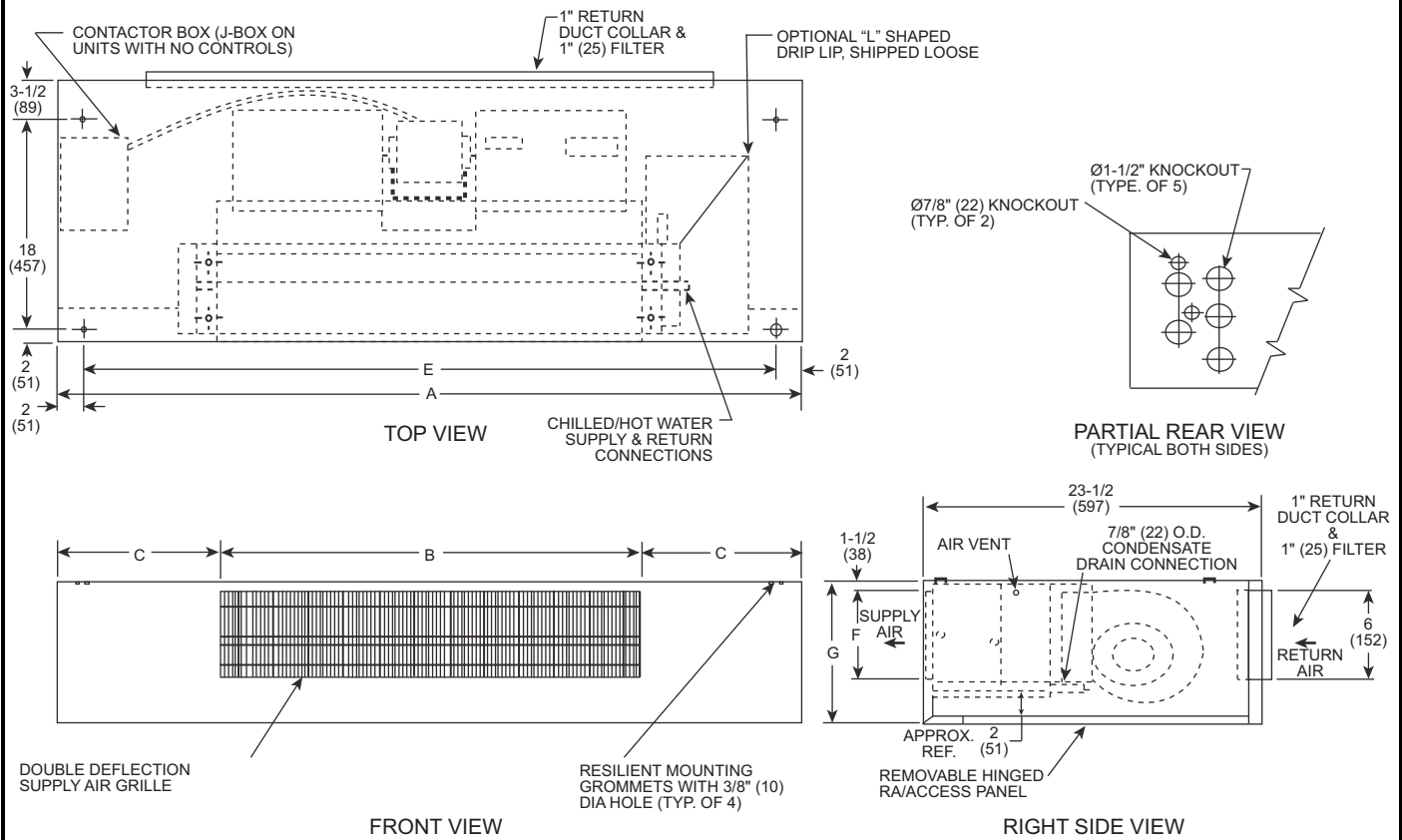

- NOTES:**
1. Right hand unit shown; left hand unit opposite.
  2. Internal factory valve package and drains may not align with cabinet knockouts.
  3. All dimensions  $\pm 1/4$ -in.
  4. Cabinet is Arctic White polyester powder coat paint.

UNIT SIZE	NOM AIRFLOW (Cfm)	DIMENSIONS (in.)						DUCTED REAR RETURN SIZE (in.)	FILTER SIZE (in.)	QTY/UNIT	
		A	B	C	E	F	G			Blower	Motor
02	200	38	17 <sup>1</sup> / <sub>8</sub>	10 <sup>7</sup> / <sub>16</sub>	34	5 <sup>3</sup> / <sub>4</sub>	11	6 x 21 <sup>1</sup> / <sub>2</sub>	8 x 23 <sup>1</sup> / <sub>2</sub>	1	1
03	300	42	21 <sup>1</sup> / <sub>2</sub>	10 <sup>1</sup> / <sub>4</sub>	38	5 <sup>3</sup> / <sub>4</sub>	11	6 x 25 <sup>3</sup> / <sub>4</sub>	8 x 28	1	1
04	400	48	25 <sup>7</sup> / <sub>8</sub>	11 <sup>1</sup> / <sub>16</sub>	44	5 <sup>3</sup> / <sub>4</sub>	11	6 x 30 <sup>1</sup> / <sub>4</sub>	8 x 32 <sup>1</sup> / <sub>2</sub>	2	1
06	600	53	34 <sup>5</sup> / <sub>8</sub>	9 <sup>9</sup> / <sub>16</sub>	49	6 <sup>3</sup> / <sub>4</sub>	12	6 x 34 <sup>1</sup> / <sub>2</sub>	8 x 37	2	1
08	800	60	39	10 <sup>1</sup> / <sub>2</sub>	56	6 <sup>3</sup> / <sub>4</sub>	12	6 x 39	8 x 41	2	1
10	1000	74	52 <sup>1</sup> / <sub>8</sub>	10 <sup>15</sup> / <sub>16</sub>	70	6 <sup>3</sup> / <sub>4</sub>	12	6 x 52	8 x 54 <sup>1</sup> / <sub>2</sub>	4	2
12	1200	82	60 <sup>7</sup> / <sub>8</sub>	10 <sup>9</sup> / <sub>16</sub>	78	6 <sup>3</sup> / <sub>4</sub>	12	6 x 60 <sup>3</sup> / <sub>4</sub>	8 x 63	4	2

# Base unit dimensions (cont)

42C Series Units

## 42CG HORIZONTAL CABINET WITH DOUBLE DEFLECTOR SUPPLY AIR GRILLE, DUCT REAR RETURN AND HEATER

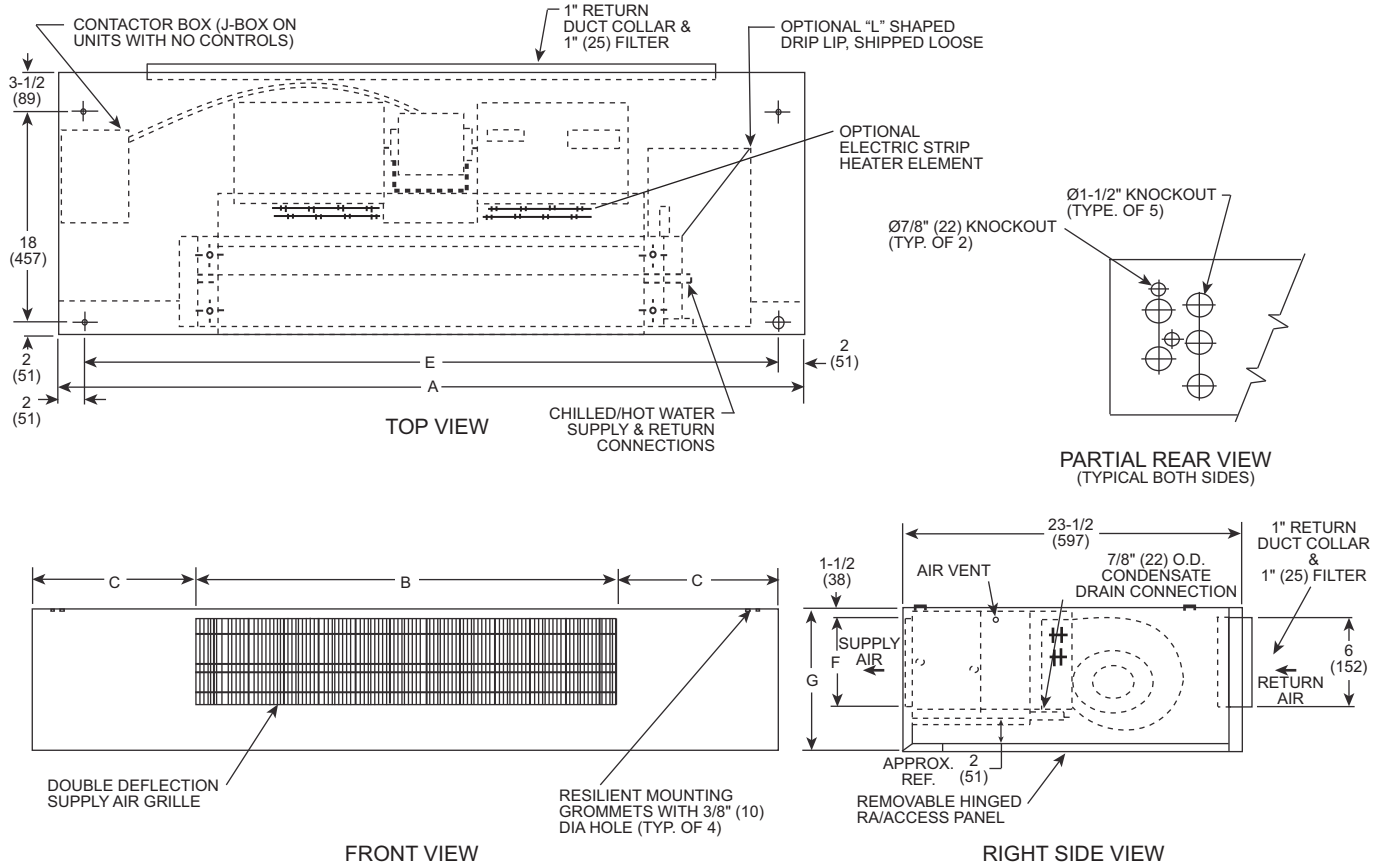

- NOTES:**
1. Right hand unit shown; left hand unit opposite.
  2. Internal factory valve package and drains may not align with cabinet knockouts.
  3. All dimensions  $\pm 1/4$ -in.
  4. Cabinet is Arctic White polyester powder coat paint.

UNIT SIZE	NOM AIRFLOW (Cfm)	DIMENSIONS (in.)						DUCTED REAR RETURN SIZE (in.)	FILTER SIZE (in.)	QTY/UNIT	
		A	B	C	E	F	G			Blower	Motor
02	200	38	17 <sup>1</sup> / <sub>8</sub>	10 <sup>7</sup> / <sub>16</sub>	34	5 <sup>3</sup> / <sub>4</sub>	11	6 x 21 <sup>1</sup> / <sub>2</sub>	8 x 23 <sup>1</sup> / <sub>2</sub>	1	1
03	300	42	21 <sup>1</sup> / <sub>2</sub>	10 <sup>1</sup> / <sub>4</sub>	38	5 <sup>3</sup> / <sub>4</sub>	11	6 x 25 <sup>3</sup> / <sub>4</sub>	8 x 28	1	1
04	400	48	25 <sup>7</sup> / <sub>8</sub>	11 <sup>1</sup> / <sub>16</sub>	44	5 <sup>3</sup> / <sub>4</sub>	11	6 x 30 <sup>1</sup> / <sub>4</sub>	8 x 32 <sup>1</sup> / <sub>2</sub>	2	1
06	600	53	34 <sup>5</sup> / <sub>8</sub>	9 <sup>3</sup> / <sub>16</sub>	49	6 <sup>3</sup> / <sub>4</sub>	12	6 x 34 <sup>1</sup> / <sub>2</sub>	8 x 37	2	1
08	800	60	39	10 <sup>1</sup> / <sub>2</sub>	56	6 <sup>3</sup> / <sub>4</sub>	12	6 x 39	8 x 41	2	1
10	1000	74	52 <sup>1</sup> / <sub>8</sub>	10 <sup>15</sup> / <sub>16</sub>	70	6 <sup>3</sup> / <sub>4</sub>	12	6 x 52	8 x 54 <sup>1</sup> / <sub>2</sub>	4	2
12	1200	82	60 <sup>7</sup> / <sub>8</sub>	10 <sup>9</sup> / <sub>16</sub>	78	6 <sup>3</sup> / <sub>4</sub>	12	6 x 60 <sup>3</sup> / <sub>4</sub>	8 x 63	4	2

### 42CG HORIZONTAL CABINET WITH STAMPED SUPPLY AIR GRILLE AND DUCT REAR RETURN

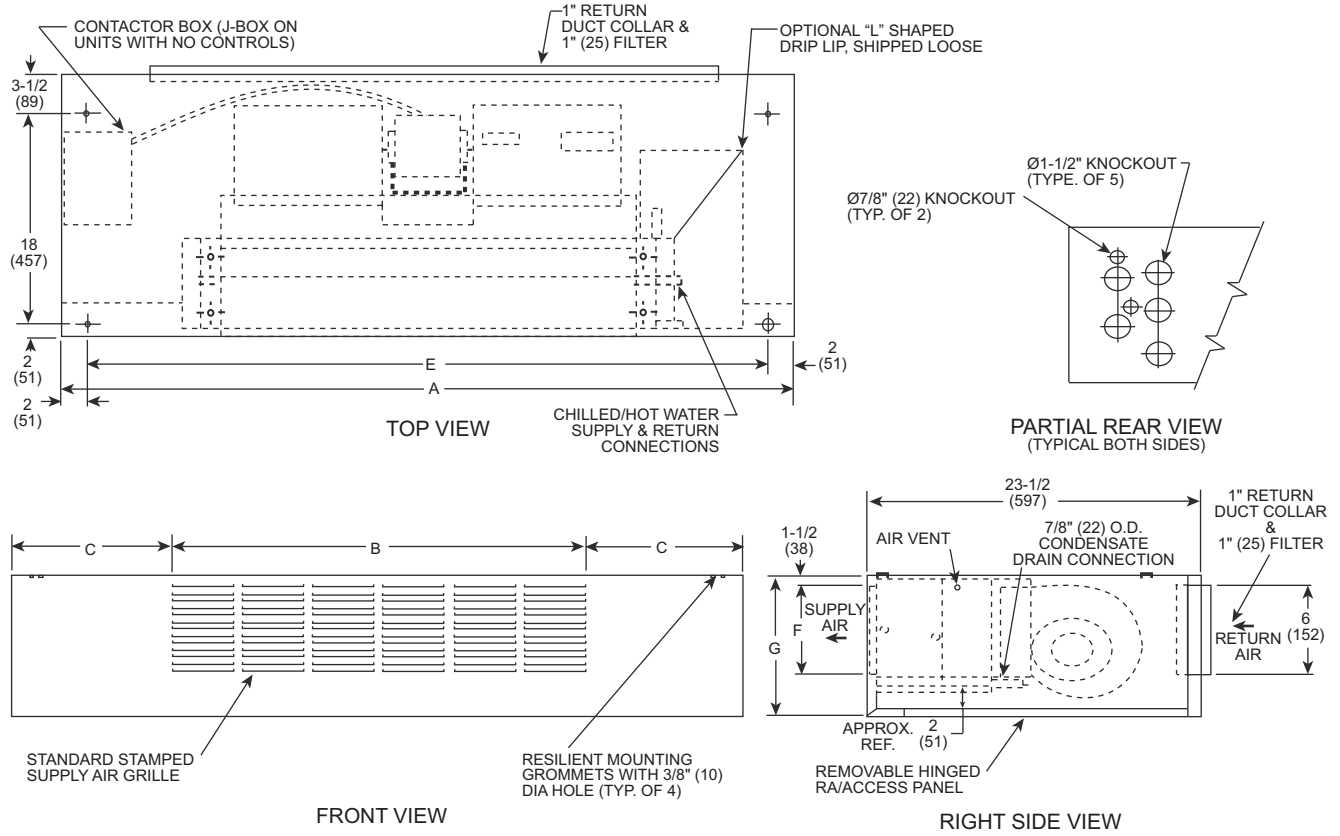

- NOTES:**
1. Right hand unit shown; left hand unit opposite.
  2. Internal factory valve package and drains may not align with cabinet knockouts.
  3. All dimensions  $\pm 1/4$ -in.
  4. Cabinet is Arctic White polyester powder coat paint.

UNIT SIZE	NOM AIRFLOW (Cfm)	DIMENSIONS (in.)						DUCTED REAR RETURN SIZE (in.)	FILTER SIZE (in.)	QTY/UNIT	
		A	B	C	E	F	G			Blower	Motor
02	200	38	17 <sup>1</sup> / <sub>8</sub>	10 <sup>7</sup> / <sub>16</sub>	34	5 <sup>3</sup> / <sub>4</sub>	11	6 x 21 <sup>1</sup> / <sub>2</sub>	8 x 23 <sup>1</sup> / <sub>2</sub>	1	1
03	300	42	21 <sup>1</sup> / <sub>2</sub>	10 <sup>1</sup> / <sub>4</sub>	38	5 <sup>3</sup> / <sub>4</sub>	11	6 x 25 <sup>3</sup> / <sub>4</sub>	8 x 28	1	1
04	400	48	25 <sup>7</sup> / <sub>8</sub>	11 <sup>1</sup> / <sub>16</sub>	44	5 <sup>3</sup> / <sub>4</sub>	11	6 x 30 <sup>1</sup> / <sub>4</sub>	8 x 32 <sup>1</sup> / <sub>2</sub>	2	1
06	600	53	34 <sup>5</sup> / <sub>8</sub>	9 <sup>3</sup> / <sub>16</sub>	49	6 <sup>3</sup> / <sub>4</sub>	12	6 x 34 <sup>1</sup> / <sub>2</sub>	8 x 37	2	1
08	800	60	39	10 <sup>1</sup> / <sub>2</sub>	56	6 <sup>3</sup> / <sub>4</sub>	12	6 x 39	8 x 41	2	1
10	1000	74	52 <sup>1</sup> / <sub>8</sub>	10 <sup>15</sup> / <sub>16</sub>	70	6 <sup>3</sup> / <sub>4</sub>	12	6 x 52	8 x 54 <sup>1</sup> / <sub>2</sub>	4	2
12	1200	82	60 <sup>7</sup> / <sub>8</sub>	10 <sup>9</sup> / <sub>16</sub>	78	6 <sup>3</sup> / <sub>4</sub>	12	6 x 60 <sup>3</sup> / <sub>4</sub>	8 x 63	4	2

# Base unit dimensions (cont)

42C Series Units

## 42CG HORIZONTAL CABINET WITH STAMPED SUPPLY AIR GRILLE, DUCTED REAR RETURN AND HEATER

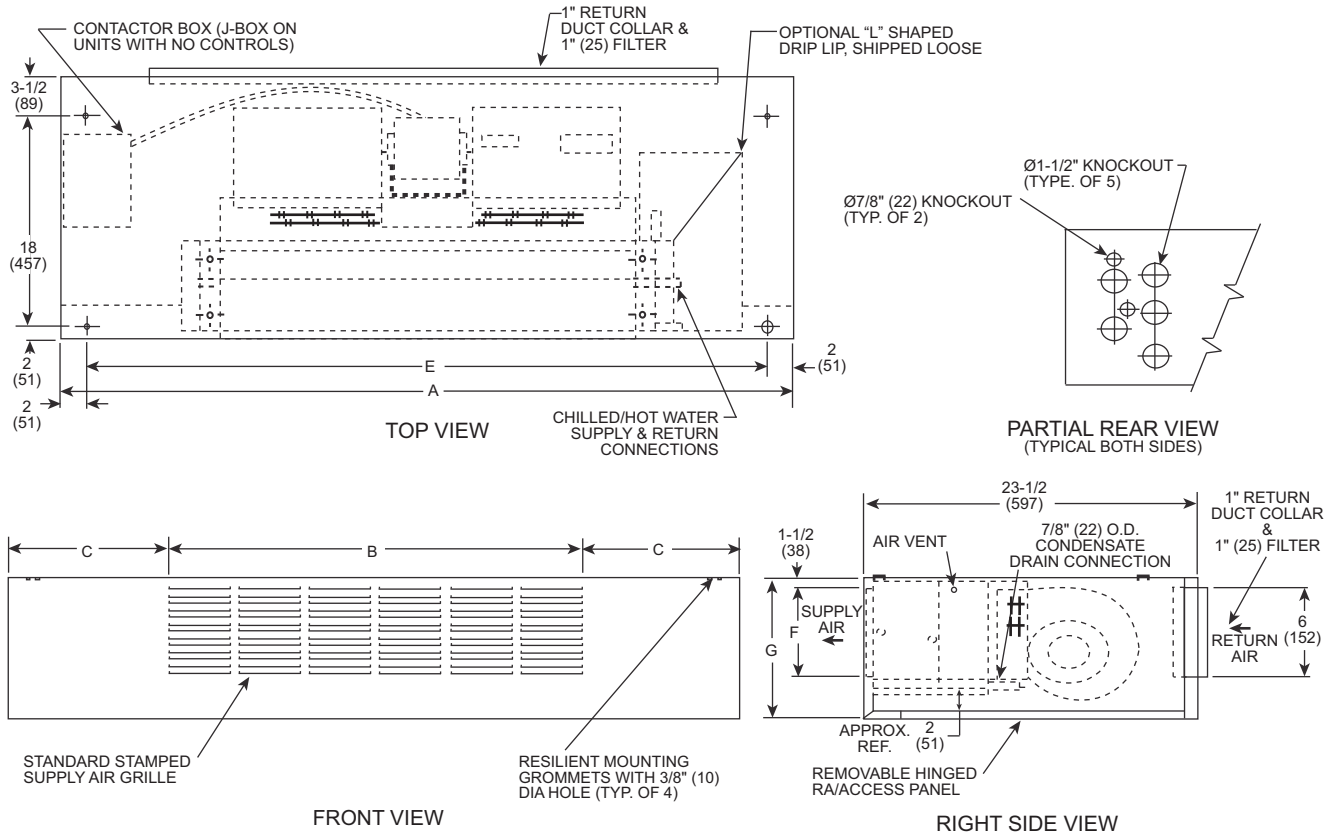

**NOTES:**

1. Right hand unit shown; left hand unit opposite.
2. Internal factory valve package and drains may not align with cabinet knockouts.
3. All dimensions  $\pm 1/4$ -in.
4. Cabinet is Arctic White polyester powder coat paint.

UNIT SIZE	NOM AIRFLOW (Cfm)	DIMENSIONS (in.)						DUCTED REAR RETURN SIZE (in.)	FILTER SIZE (in.)	QTY/UNIT	
		A	B	C	E	F	G			Blower	Motor
02	200	38	17 <sup>1</sup> / <sub>8</sub>	10 <sup>7</sup> / <sub>16</sub>	34	5 <sup>3</sup> / <sub>4</sub>	11	6 x 21 <sup>1</sup> / <sub>2</sub>	8 x 23 <sup>1</sup> / <sub>2</sub>	1	1
03	300	42	21 <sup>1</sup> / <sub>2</sub>	10 <sup>1</sup> / <sub>4</sub>	38	5 <sup>3</sup> / <sub>4</sub>	11	6 x 25 <sup>3</sup> / <sub>4</sub>	8 x 28	1	1
04	400	48	25 <sup>7</sup> / <sub>8</sub>	11 <sup>1</sup> / <sub>16</sub>	44	5 <sup>3</sup> / <sub>4</sub>	11	6 x 30 <sup>1</sup> / <sub>4</sub>	8 x 32 <sup>1</sup> / <sub>2</sub>	2	1
06	600	53	34 <sup>5</sup> / <sub>8</sub>	9 <sup>3</sup> / <sub>16</sub>	49	6 <sup>3</sup> / <sub>4</sub>	12	6 x 34 <sup>1</sup> / <sub>2</sub>	8 x 37	2	1
08	800	60	39	10 <sup>1</sup> / <sub>2</sub>	56	6 <sup>3</sup> / <sub>4</sub>	12	6 x 39	8 x 41	2	1
10	1000	74	52 <sup>1</sup> / <sub>8</sub>	10 <sup>15</sup> / <sub>16</sub>	70	6 <sup>3</sup> / <sub>4</sub>	12	6 x 52	8 x 54 <sup>1</sup> / <sub>2</sub>	4	2
12	1200	82	60 <sup>7</sup> / <sub>8</sub>	10 <sup>9</sup> / <sub>16</sub>	78	6 <sup>3</sup> / <sub>4</sub>	12	6 x 60 <sup>3</sup> / <sub>4</sub>	8 x 63	4	2

### 42CK HORIZONTAL CABINET UNIT WITH TELESCOPIC ACCESS PANEL, FRONT SUPPLY, AND BOTTOM RETURN

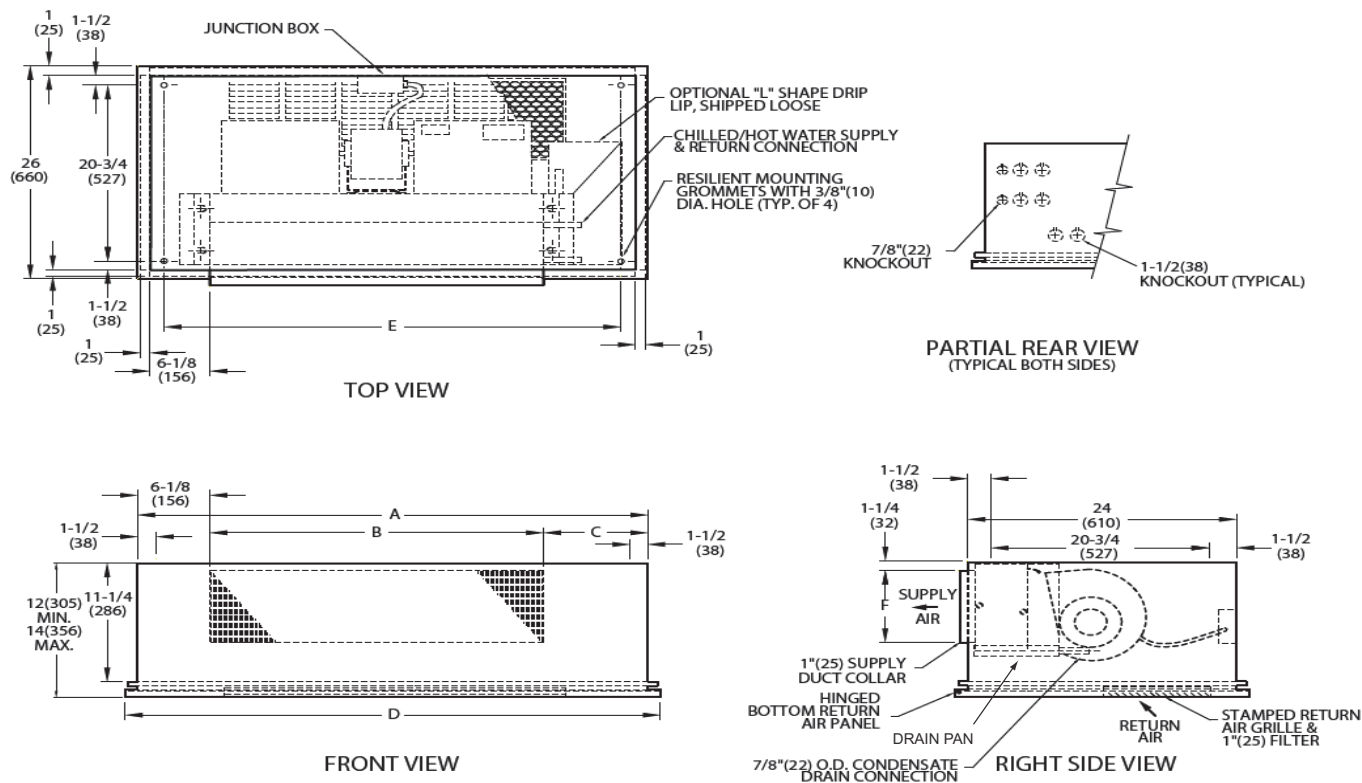

**NOTES:**

1. Right hand unit shown; left hand unit opposite.
2. Internal factory valve package and drains may not align with cabinet knockouts.
3. Dimensions shown in inches (mm). All dimensions are  $\pm 1/4$  inches.
4. Bottom panel is Arctic White polyester powder coat paint.

UNIT SIZE	NOM AIRFLOW (Cfm)	DIMENSIONS (in.)						QTY/UNIT		BOTTOM RETURN FILTER SIZE (in.)	UNIT WEIGHT* (lb)
		A	B	C	D	E	F	Blower	Motor		
02	200	35	16	12 <sup>3/4</sup>	37	32	6	1	1	10 x 21	115
03	300	35	20	8 <sup>3/4</sup>	37	32	6	1	1	10 x 21	120
04	400	41	26	8 <sup>3/4</sup>	43	38	6	2	1	10 x 27	135
06	600	53	31	15 <sup>3/4</sup>	55	50	7	2	1	10 x 38	150
08	800	53	38	8 <sup>3/4</sup>	55	50	7	2	1	10 x 38	155
10	1000	75	52	16 <sup>3/4</sup>	77	72	7	4	2	10 x 52	227
12	1200	75	60	8 <sup>3/4</sup>	77	72	7	4	2	10 x 52	241

\*Unit weights are based on dry coils and minimum rows. Weights exclude packaging, valves, and other components.

# Base unit dimensions (cont)

42C Series Units

## 42CK HORIZONTAL CABINET UNIT WITH TELESCOPIC ACCESS PANEL, FRONT SUPPLY, BOTTOM RETURN, AND HEATER

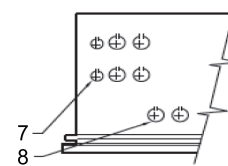
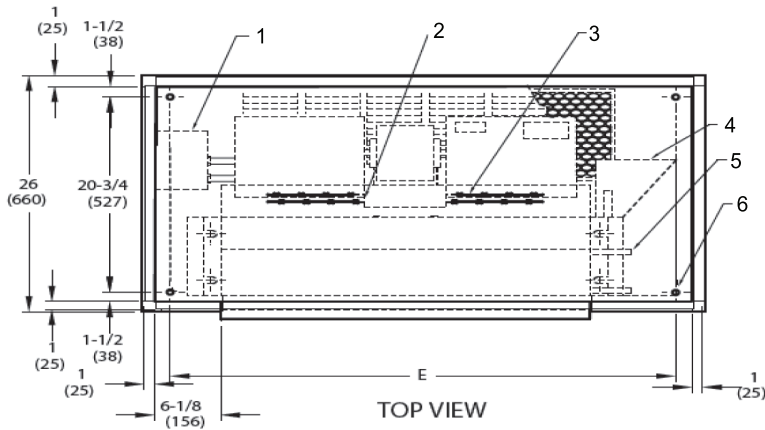

PARTIAL REAR VIEW  
(TYPICAL BOTH SIDES)

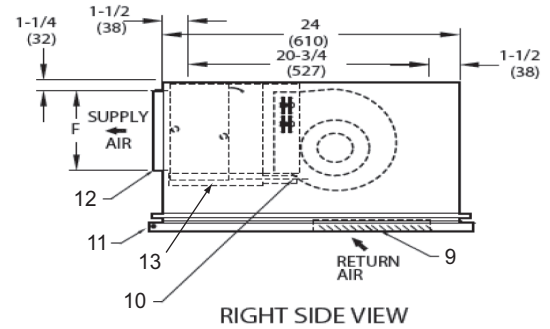
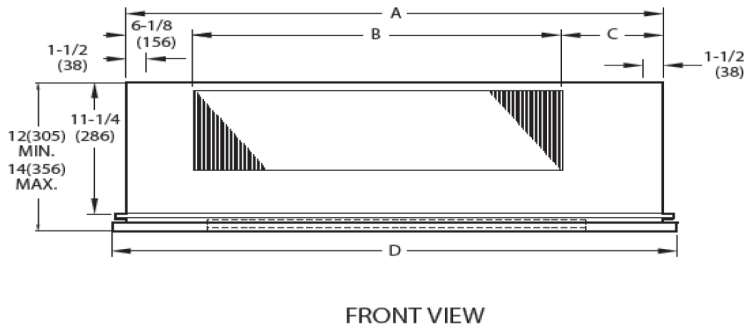

### LEGEND

- 1 — Contactor Box
- 2 — Strip Heater High Limit
- 3 — Electric Strip Heater Element
- 4 — Optimal L-shape Drip Lip, shipped loose
- 5 — Chilled/Hot Water Supply and Return Connection
- 6 — Resilient Mounting Grommets with  $\frac{3}{8}$ -in. Diameter Hole (typically 4)
- 7 — Electrical Knockout,  $\frac{7}{8}$ -in. Diameter
- 8 — Drain Knockout,  $1\frac{1}{2}$ -in. Diameter
- 9 — Stamped Return Air Grille and 1-in. Filter
- 10 — Condensate Drain Connection,  $\frac{7}{8}$ -in. OD
- 11 — Hinged Bottom Return Air Panel
- 12 — Supply Duct Collar, 1-in. OD
- 13 — Drain Pan

### NOTES:

- 1. Right hand unit shown; left hand unit opposite.
- 2. Internal factory valve package and drains may not align with cabinet knockouts.
- 3. Dimensions shown in inches (mm). All dimensions are  $\pm\frac{1}{4}$  inches.
- 4. Bottom panel is Arctic White polyester powder coat paint.

UNIT SIZE	NOM AIRFLOW (Cfm)	DIMENSIONS (in.)						QTY/UNIT		BOTTOM RETURN FILTER SIZE (in.)	UNIT WEIGHT* (lb)
		A	B	C	D	E	F	Blower	Motor		
02	200	35	16	12 <sup>3</sup> / <sub>4</sub>	37	32	6	1	1	10 x 21	117
03	300	35	20	8 <sup>3</sup> / <sub>4</sub>	37	32	6	1	1	10 x 21	122
04	400	41	26	8 <sup>3</sup> / <sub>4</sub>	43	38	6	2	1	10 x 27	137
06	600	53	31	15 <sup>3</sup> / <sub>4</sub>	55	50	7	2	1	10 x 38	152
08	800	53	38	8 <sup>3</sup> / <sub>4</sub>	55	50	7	2	1	10 x 38	157
10	1000	75	52	16 <sup>3</sup> / <sub>4</sub>	77	72	7	4	2	10 x 52	229
12	1200	75	60	8 <sup>3</sup> / <sub>4</sub>	77	72	7	4	2	10 x 52	243

\*Unit weights are based on dry coils and minimum rows. Weights exclude packaging, valves, and other components.



**42CK HORIZONTAL CABINET UNIT WITH TELESCOPIC ACCESS PANEL, FRONT SUPPLY, AND REAR RETURN**

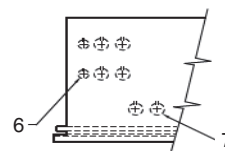
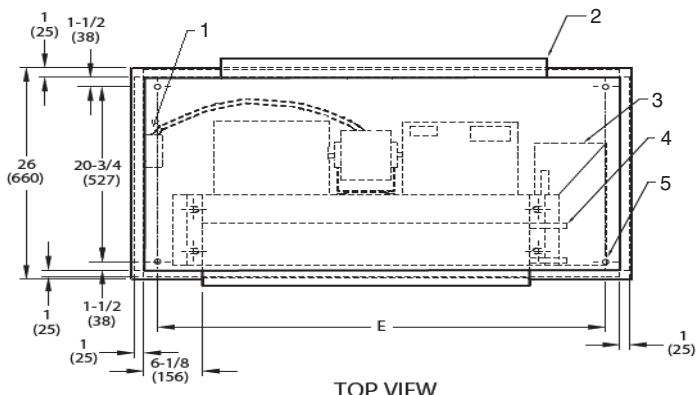

PARTIAL REAR VIEW  
(TYPICAL BOTH SIDES)

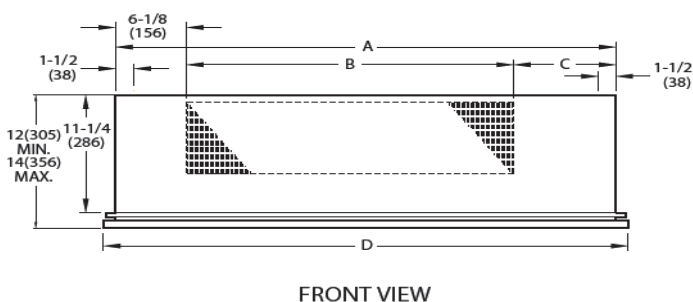

FRONT VIEW

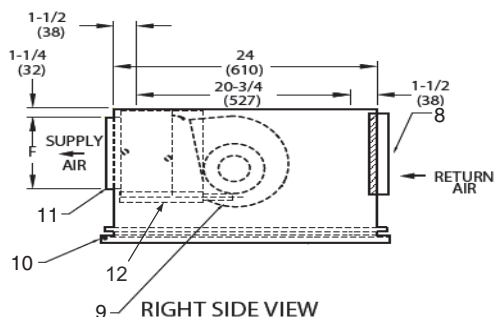

RIGHT SIDE VIEW

**LEGEND**

- 1 — Junction Box
- 2 — 1-in. Ducted Rear Return and 1-in. Filter
- 3 — Optimal L-shape Drip Lip, shipped loose
- 4 — Chilled/Hot Water Supply and Return Connection
- 5 — Resilient Mounting Grommets with 3/8-in. Diameter Hole (typically 4)
- 6 — Electrical Knockout, 7/8-in. Diameter
- 7 — Drain Knockout, 1 1/2-in. Diameter
- 8 — 1-in. Ducted Rear Return and 1-in. Filter
- 9 — Condensate Drain Connection, 7/8-in. OD
- 10 — Hinged Bottom Return Air Panel
- 11 — Supply Duct Collar, 1-in. OD
- 12 — Drain Pan

**NOTES:**

- 1. Right hand unit shown; left hand unit opposite.
- 2. Internal factory valve package and drains may not align with cabinet knockouts.
- 3. Dimensions shown in inches (mm). All dimensions are ±1/4 inches.
- 4. Bottom panel is Arctic White polyester powder coat paint.

UNIT SIZE	NOM AIRFLOW (Cfm)	DIMENSIONS (in.)						QTY/UNIT		REAR RETURN FILTER SIZE (in.)	UNIT WEIGHT* (lb)
		A	B	C	D	E	F	Blower	Motor		
02	200	35	16	12 <sup>3</sup> / <sub>4</sub>	37	32	6	1	1	7 x 21	115
03	300	35	20	8 <sup>3</sup> / <sub>4</sub>	37	32	6	1	1	7 x 21	120
04	400	41	26	8 <sup>3</sup> / <sub>4</sub>	43	38	6	2	1	7 x 27	135
06	600	53	31	15 <sup>3</sup> / <sub>4</sub>	55	50	7	2	1	7 x 38	150
08	800	53	38	8 <sup>3</sup> / <sub>4</sub>	55	50	7	2	1	7 x 38	155
10	1000	75	52	16 <sup>3</sup> / <sub>4</sub>	77	72	7	4	2	7 x 52	227
12	1200	75	60	8 <sup>3</sup> / <sub>4</sub>	77	72	7	4	2	7 x 52	241

\*Unit weights are based on dry coils and minimum rows. Weights exclude packaging, valves, and other components.

# Base unit dimensions (cont)

42C Series Units

## 42CK HORIZONTAL CABINET UNIT WITH TELESCOPIC ACCESS PANEL, FRONT SUPPLY, REAR RETURN, AND HEATER

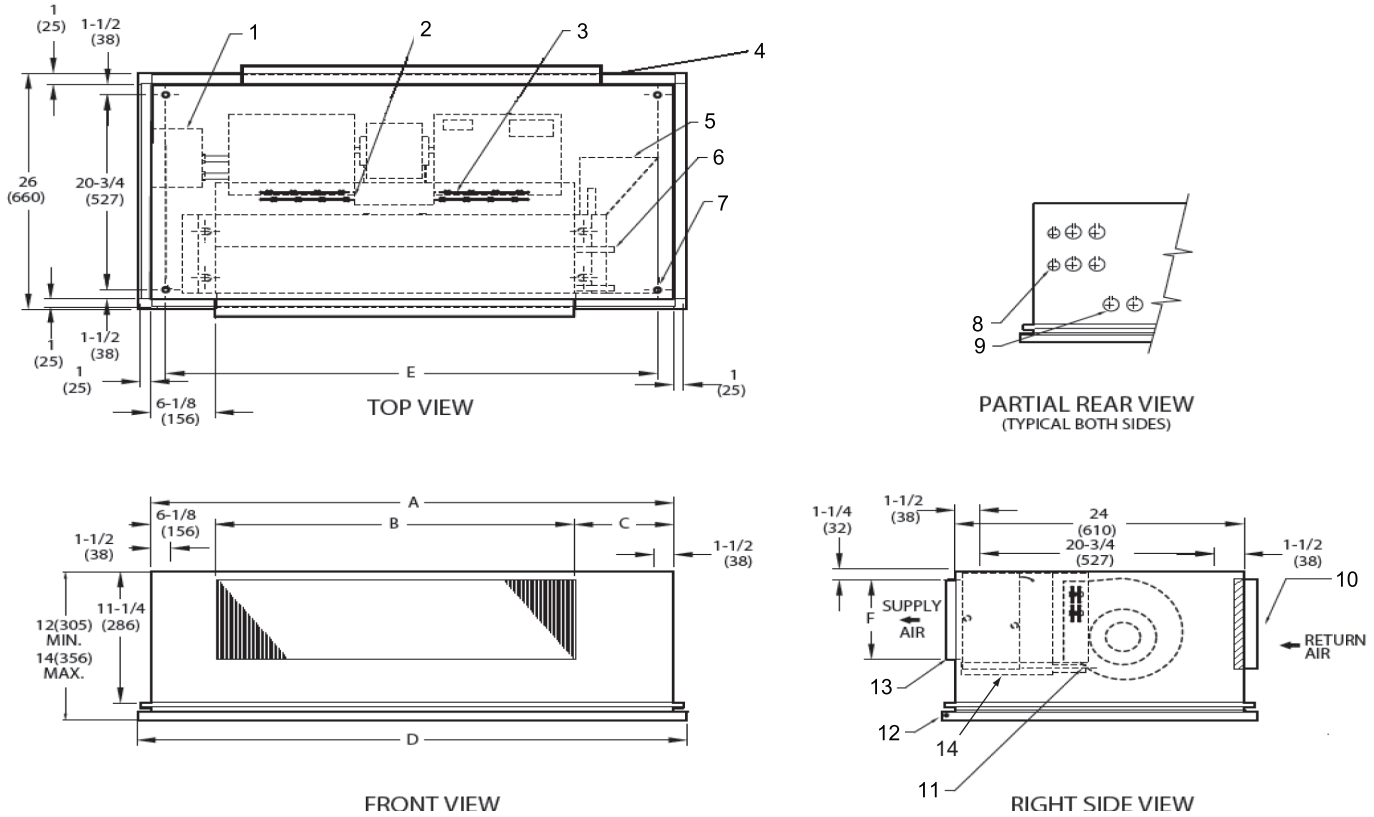

### LEGEND

- 1 — Contactor Box
- 2 — Strip Heater High Limit
- 3 — Electric Strip Heater Element
- 4 — 1-in. Ducted Rear Return and 1-in. Filter
- 5 — Optimal L-shape Drip Lip, shipped loose
- 6 — Chilled/Hot Water Supply and Return Connection
- 7 — Resilient Mounting Grommets with 3/8-in. Diameter Hole (typically 4)
- 8 — Electrical Knockout, 7/8-in. Diameter
- 9 — Drain Knockout, 1 1/2-in. Diameter
- 10 — 1-in. Ducted Rear Return and 1-in. Filter
- 11 — Condensate Drain Connection, 7/8-in. OD
- 12 — Hinged Bottom Return Air Panel
- 13 — Supply Duct Collar, 1-in. OD
- 14 — Drain Pan

### NOTES:

- 1. Right hand unit shown; left hand unit opposite.
- 2. Internal factory valve package and drains may not align with cabinet knockouts.
- 3. Dimensions shown in inches (mm). All dimensions are ±1/4 inches.
- 4. Bottom panel is Arctic White polyester powder coat paint.

UNIT SIZE	NOM AIRFLOW (Cfm)	DIMENSIONS (in.)						QTY/UNIT		REAR RETURN FILTER SIZE (in.)	UNIT WEIGHT* (lb)
		A	B	C	D	E	F	Blower	Motor		
02	200	35	16	12 <sup>3</sup> / <sub>4</sub>	37	32	6	1	1	7 x 21	117
03	300	35	20	8 <sup>3</sup> / <sub>4</sub>	37	32	6	1	1	7 x 21	122
04	400	41	26	8 <sup>3</sup> / <sub>4</sub>	43	38	6	2	1	7 x 27	137
06	600	53	31	15 <sup>3</sup> / <sub>4</sub>	55	50	7	2	1	7 x 38	152
08	800	53	38	8 <sup>3</sup> / <sub>4</sub>	55	50	7	2	1	7 x 38	157
10	1000	75	52	16 <sup>3</sup> / <sub>4</sub>	77	72	7	4	2	7 x 52	229
12	1200	75	60	8 <sup>3</sup> / <sub>4</sub>	77	72	7	4	2	7 x 52	243

\*Unit weights are based on dry coils and minimum rows. Weights exclude packaging, valves, and other components.

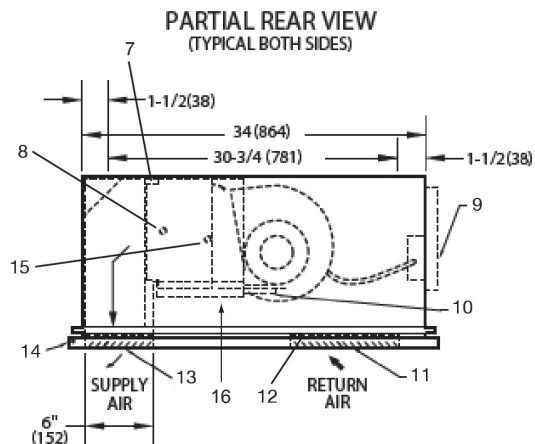
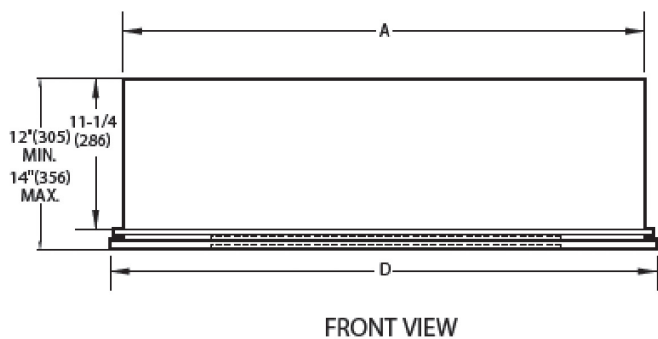
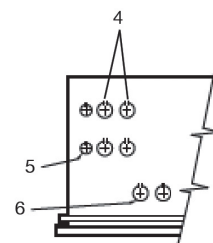
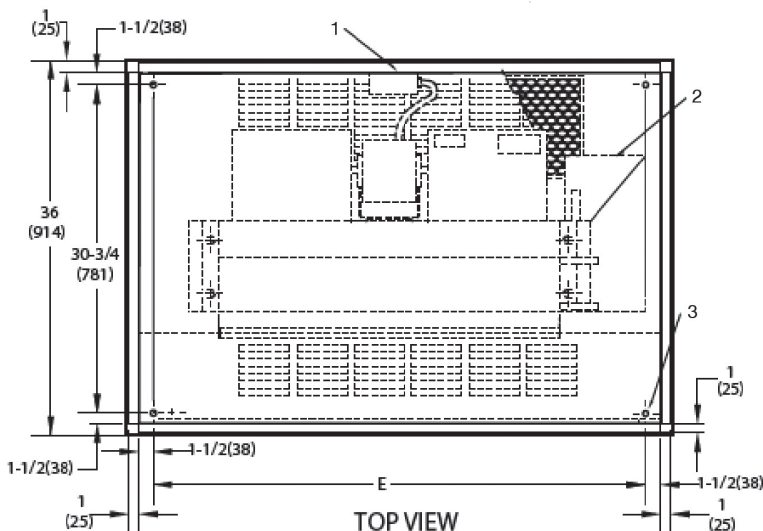
**42CK HORIZONTAL CABINET UNIT WITH TELESCOPIC ACCESS PANEL, BOTTOM SUPPLY, BOTTOM RETURN\***

**LEGEND**

- 1 — Junction Box, 4 in. x 4 in.
- 2 — Optional Drip Lip, shipped loose
- 3 — Mounting Holes (4), Rubber Grommets have 3/8-in. Diameter Hole
- 4 — Piping Knockout, 1 1/2-in. Diameter
- 5 — Electrical Knockout, 7/8-in. Diameter
- 6 — Drain Knockout, 1 1/2-in. Diameter
- 7 — Supply Duct Collar
- 8 — Return Connection
- 9 — Optional Rear Return. Consult factory for collar dimensions.
- 10 — Drain, 7/8-in. OD.
- 11 — Stamped Bottom Return Air Grille
- 12 — Filter
- 13 — Stamped Air Supply Grille
- 14 — Hinged Bottom Access Panel
- 15 — Supply Connection
- 16 — Drain Pan

\* ETO — Engineered to Order.

**NOTES:**

1. Right hand unit shown; left hand unit opposite. Coil connection locations are  $\pm 5/8$ -inches.
2. Unit sizes 02 and 03 have one motor, one blower; sizes 04 through 08 have one motor, 2 blowers; sizes 10 and 12 have 2 motors, 4 blowers.
3. Bottom access panel has an Arctic White baked finish.
4. Refer to supply and return connections above for coil stub-out locations.
5. Not shown: optional drip lip, 3-speed fan switch; wall plate, 1/2-in. fiberglass insulation on inside of casing, closed cell foam on main drain pan.
6. See 42CA-203-1 for optional coil connections.
7. Valve package is factory-installed inside the cabinet when ordered with the unit (based on component size).
8. Bottom return or bottom supply is an ETO (engineering to order) request.
9. Dimensions shown in inches (mm).

UNIT SIZE	NOM AIRFLOW (Cfm)	DIMENSIONS (in.)			QTY/UNIT		FACE AREA (sq ft)	UNIT WEIGHT† (lb)
		A	D	E	Blower	Motor		
02	200	35	37	32	1	1	0.83	115
03	300	35	37	32	1	1	1.08	120
04	400	41	43	38	2	1	1.35	135
06	600	53	55	50	2	1	1.88	150
08	800	53	55	50	2	1	2.31	155
10	1000	75	77	72	4	2	3.16	227
12	1200	75	77	72	4	2	3.65	241

†Unit weights are based on dry coils and minimum rows. Weights exclude packaging, valves, and other components.

# Base unit dimensions (cont)

42C Series Units

## 42CK HORIZONTAL CABINET WITH TELESCOPIC ACCESS PANEL BOTTOM SUPPLY, BOTTOM RETURN, AND ELECTRIC HEAT\*

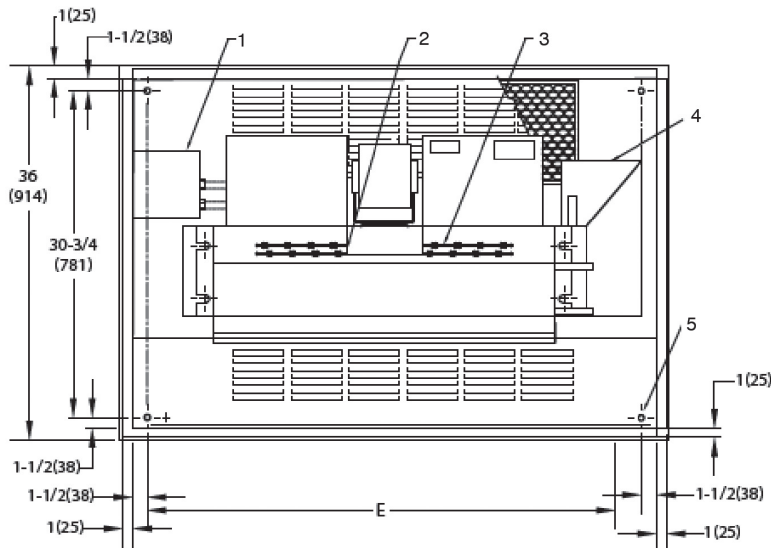

TOP VIEW

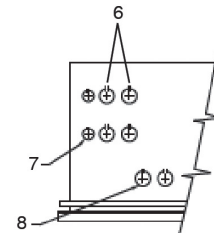

PARTIAL REAR VIEW  
(TYPICAL BOTH SIDES)

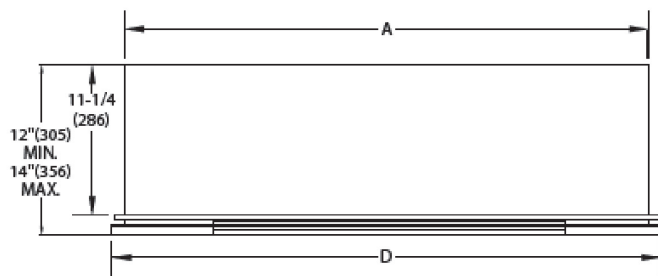

FRONT VIEW

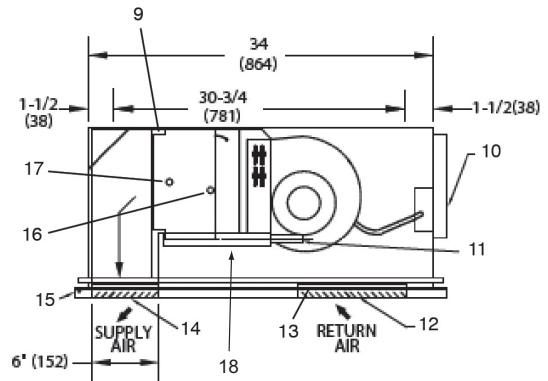

RIGHT SIDE VIEW

LEGEND

- 1 — Junction Box, 4 in. x 4 in.
- 2 — Strip Heater High Limit
- 3 — Electric Strip Heater Element
- 4 — Optional Drip Lip, shipped loose
- 5 — Mounting Holes (4), Rubber Grommets have 3/8-in. Diameter Hole
- 6 — Piping Knockout, 1 1/2-in. Diameter
- 7 — Electrical Knockout, 7/8-in. Diameter
- 8 — Drain Knockout, 1 1/2-in. Diameter
- 9 — Supply Duct Collar
- 10 — Optional Rear Return. Consult factory for collar dimensions.
- 11 — Drain, 7/8-in. OD.
- 12 — Stamped Bottom Return Air Grille
- 13 — Filter
- 14 — Stamped Air Supply Grille
- 15 — Hinged Bottom Access Panel
- 16 — Supply Connection
- 17 — Return Connection
- 18 — Drain Pan

\* ETO — Engineered to Order.

NOTES:

- 1. Right hand unit shown; left hand unit opposite. Coil connection locations are ±5/8-inches.
- 2. Unit sizes 02 and 03 have one motor, one blower; sizes 04 through 08 have one motor, 2 blowers; sizes 10 and 12 have 2 motors, 4 blowers.
- 3. Bottom access panel has an Arctic White baked finish.
- 4. Refer to supply and return connections above for coil stub-out locations.
- 5. Not shown: optional drip lip, 3-speed fan switch; wall plate, 1/2-in. fiberglass insulation on inside of casing, closed cell foam on main drain pan.
- 6. See 42CA-203-1 for optional coil connections.
- 7. Valve package is factory-installed inside the cabinet when ordered with the unit (based on component size).
- 8. Bottom return or bottom supply is an ETO (engineering to order) request.
- 9. Dimensions shown in inches (mm).

UNIT SIZE	NOM AIRFLOW (Cfm)	DIMENSIONS (in.)			QTY/UNIT		FACE AREA (sq ft)	UNIT WEIGHT† (lb)
		A	D	E	Blower	Motor		
02	200	35	37	32	1	1	0.83	117
03	300	35	37	32	1	1	1.08	122
04	400	41	43	38	2	1	1.35	137
06	600	53	55	50	2	1	1.88	152
08	800	53	55	50	2	1	2.31	157
10	1000	75	77	72	4	2	3.16	229
12	1200	75	77	72	4	2	3.65	243

†Unit weights are based on dry coils and minimum rows. Weights exclude packaging, valves, and other components.

# Accessory dimensions

## DISCHARGE AIR GRILLES

DISCHARGE GRILLES		
Unit Size	Nominal Airflow (Cfm)	Recommended Grille Sizes (in.)
		Unit 42C*
02	200	16 x 6
03	300	20 x 6
04	400	26 x 6
06	600	30 x 6
08	800	38 x 6
10	1000	52 x 6
12	1200	60 x 6

\*Refer to unit dimensions to size field transitions.

## INTEGRAL DOUBLE-DEFLECTION GRILLE FOR HORIZONTAL UNITS (Installed on 42CG Unit as Shown)

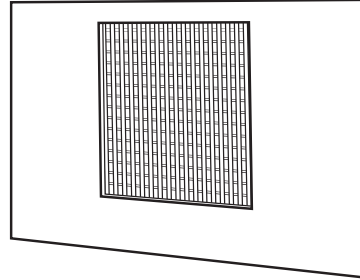

# Performance data



42C Series Units

**AIR DELIVERY FAN CURVES**  
42CE SERIES — 02 UNIT SIZE

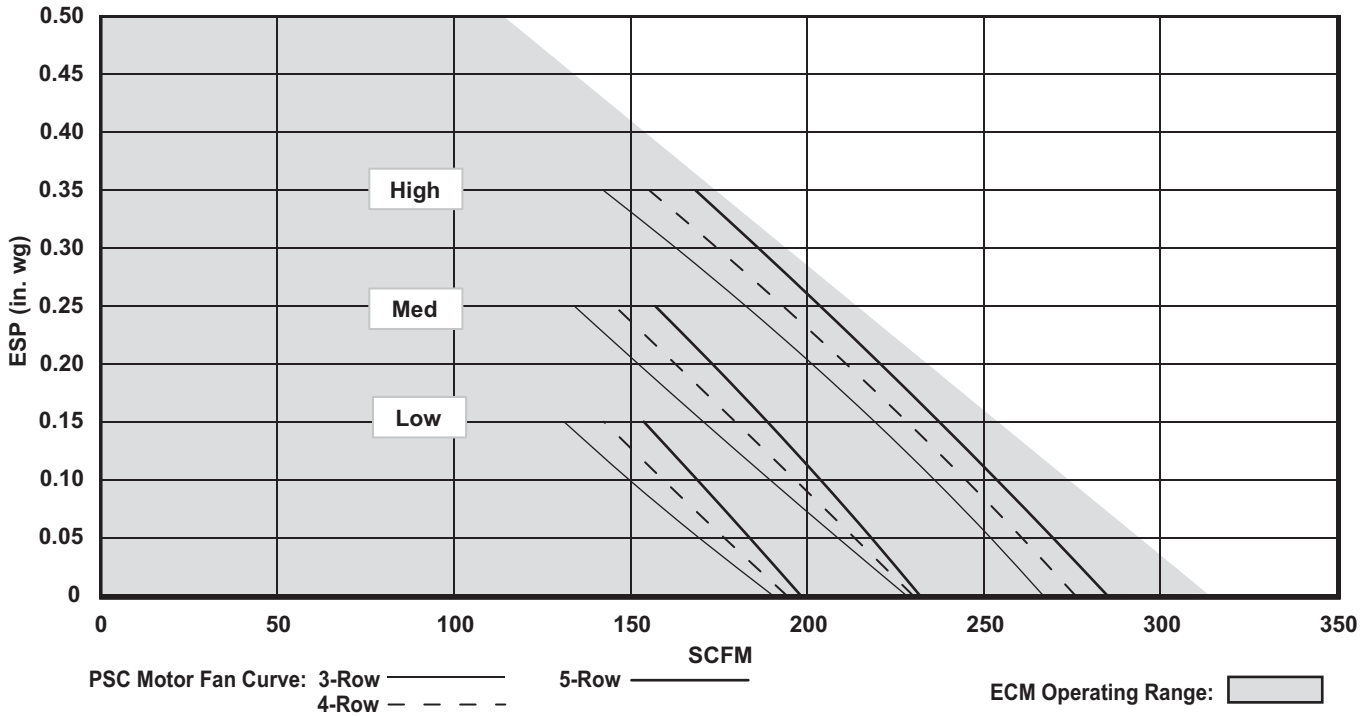

**42CE SERIES — 03 UNIT SIZE**

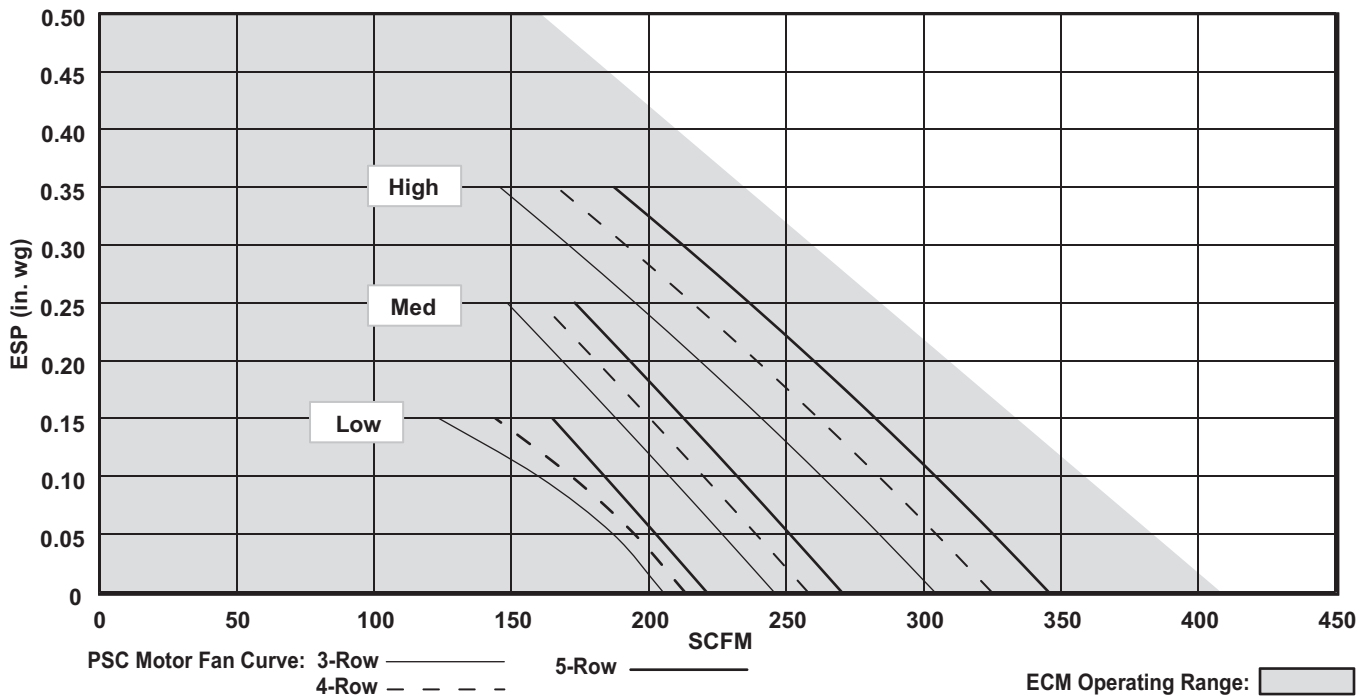

**LEGEND**

- ECM** — Electronically Commutated Motor
- ESP** — External Static Pressure
- PSC** — Permanent Split Capacitor
- SCFM** — Square Cubic Feet per Minute

**AIR DELIVERY FAN CURVES (cont)**  
**42CE SERIES — 04 UNIT SIZE**

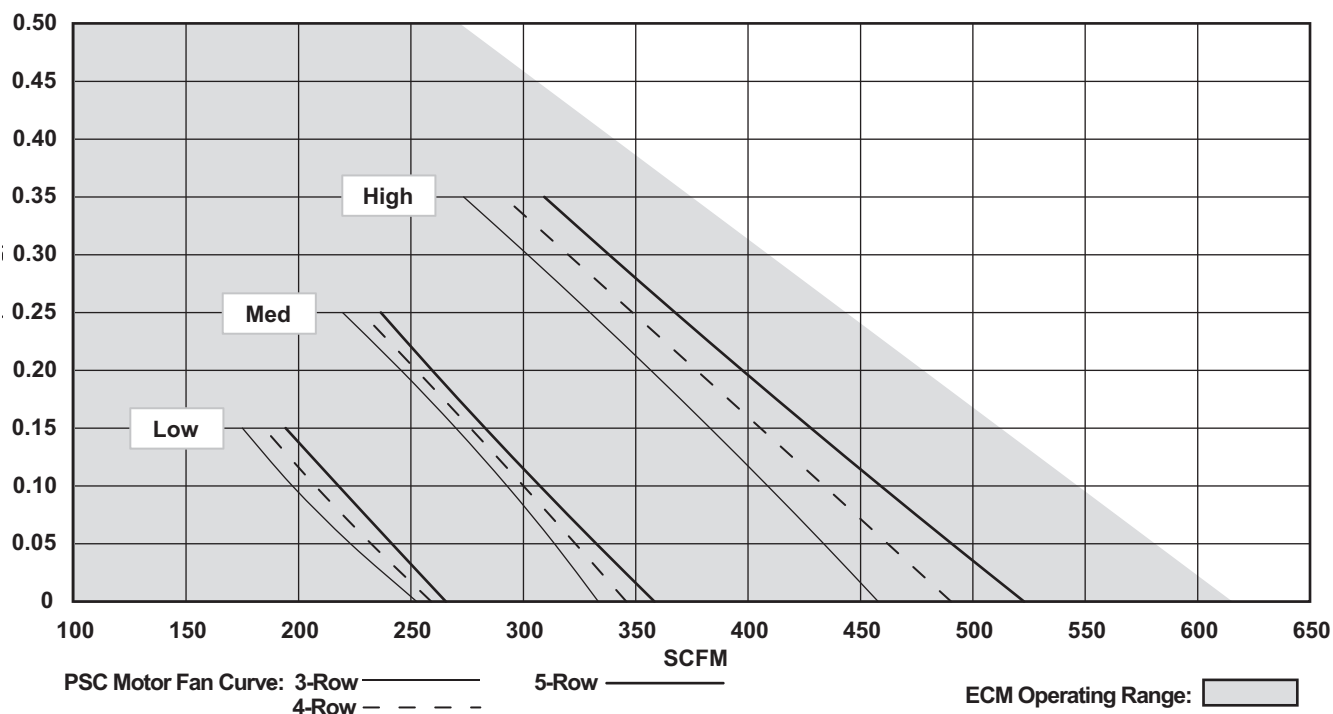

**42CE SERIES — 06 UNIT SIZE**

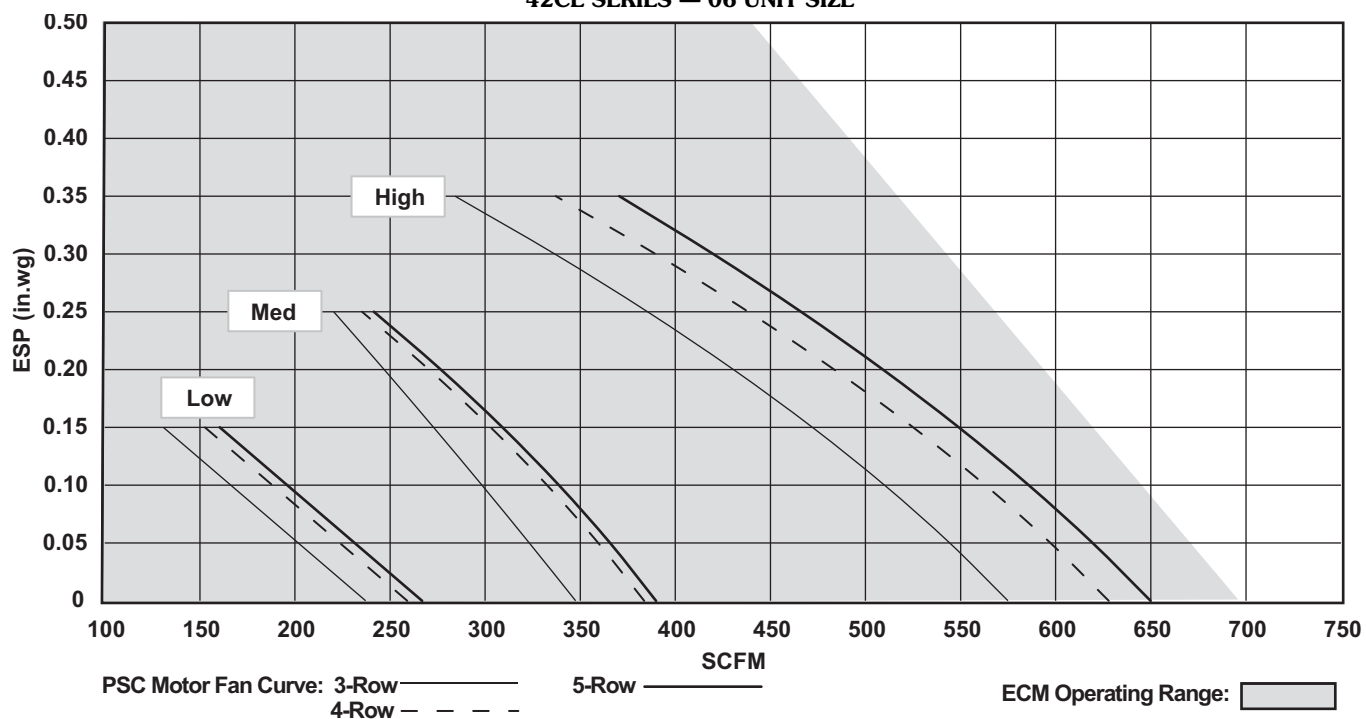

**LEGEND**

- ECM** — Electronically Commutated Motor
- ESP** — External Static Pressure
- PSC** — Permanent Split Capacitor
- SCFM** — Square Cubic Feet per Minute

# Performance data (cont)



42C Series Units

**AIR DELIVERY FAN CURVES (cont)**  
**42CE SERIES — 08 UNIT SIZE**

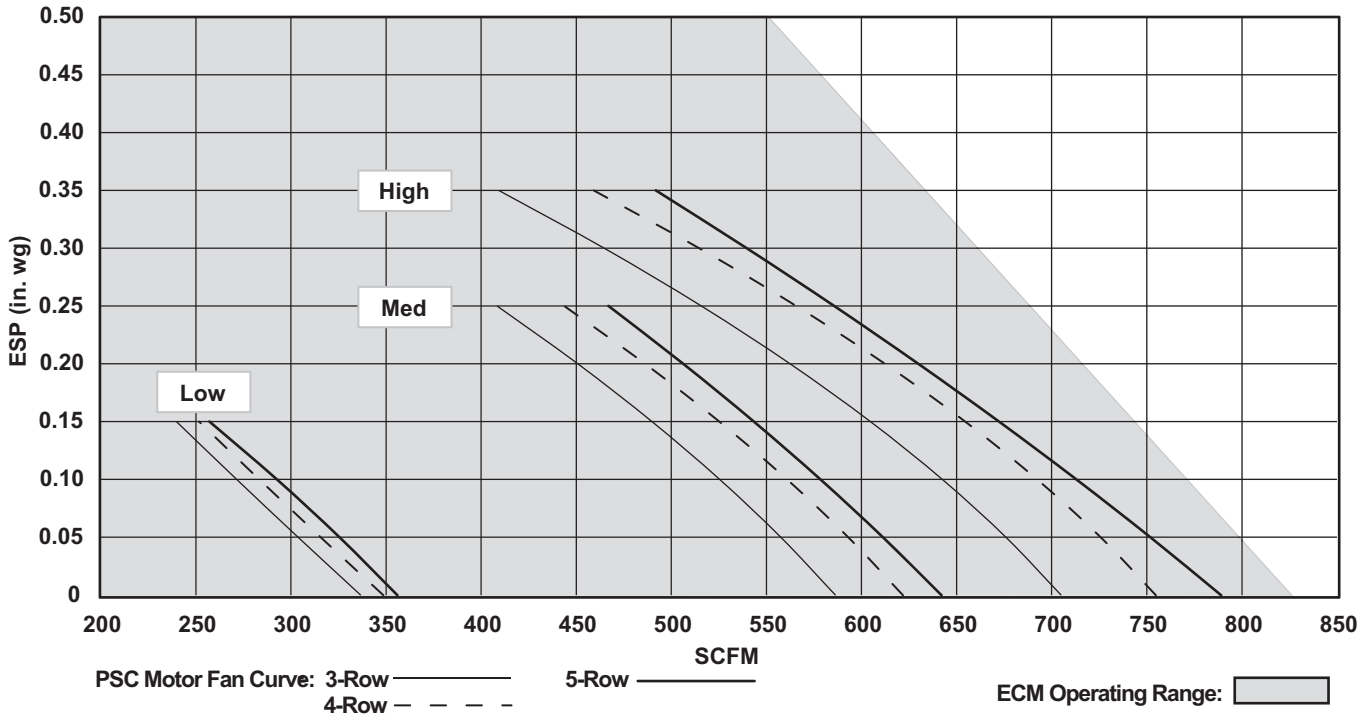

**42CE SERIES — 10 UNIT SIZE**

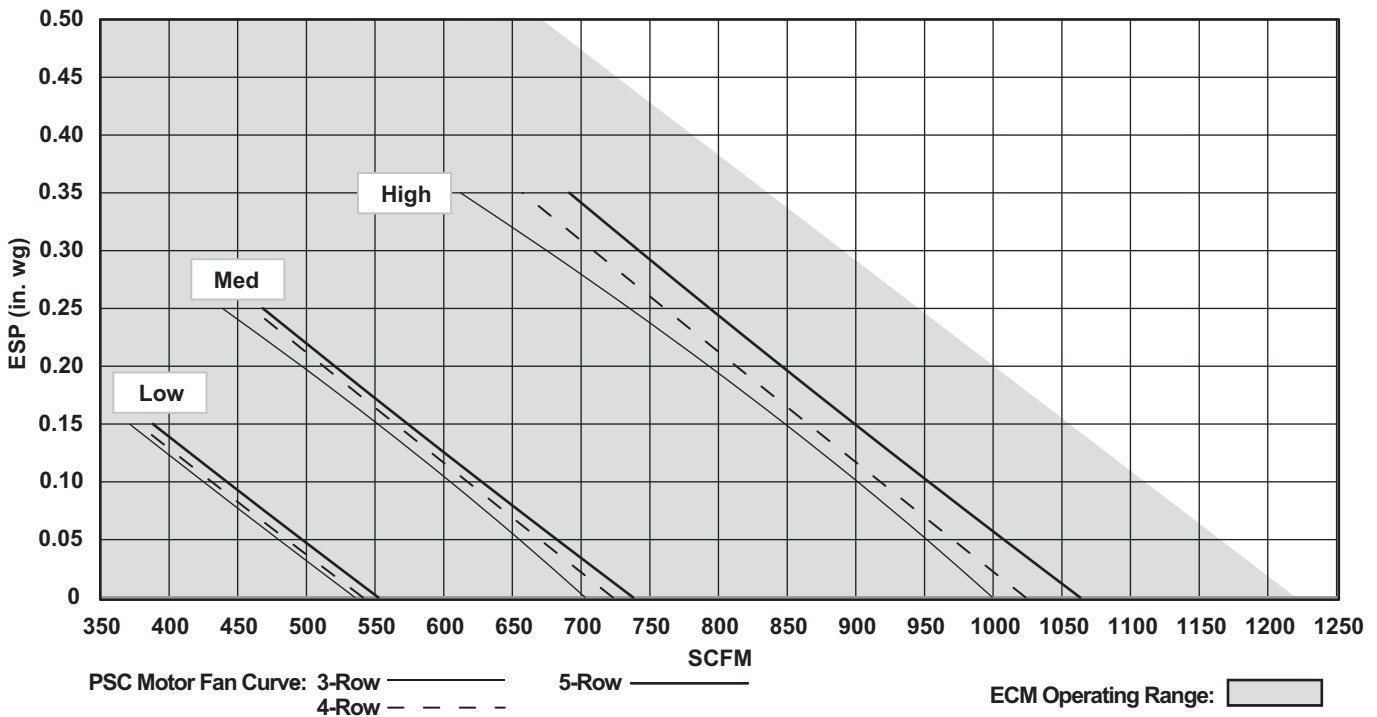

**LEGEND**

- ECM — Electronically Commutated Motor
- ESP — External Static Pressure
- PSC — Permanent Split Capacitor
- SCFM — Square Cubic Feet per Minute



**AIR DELIVERY FAN CURVES (cont)**  
**42CE SERIES — 12 UNIT SIZE**

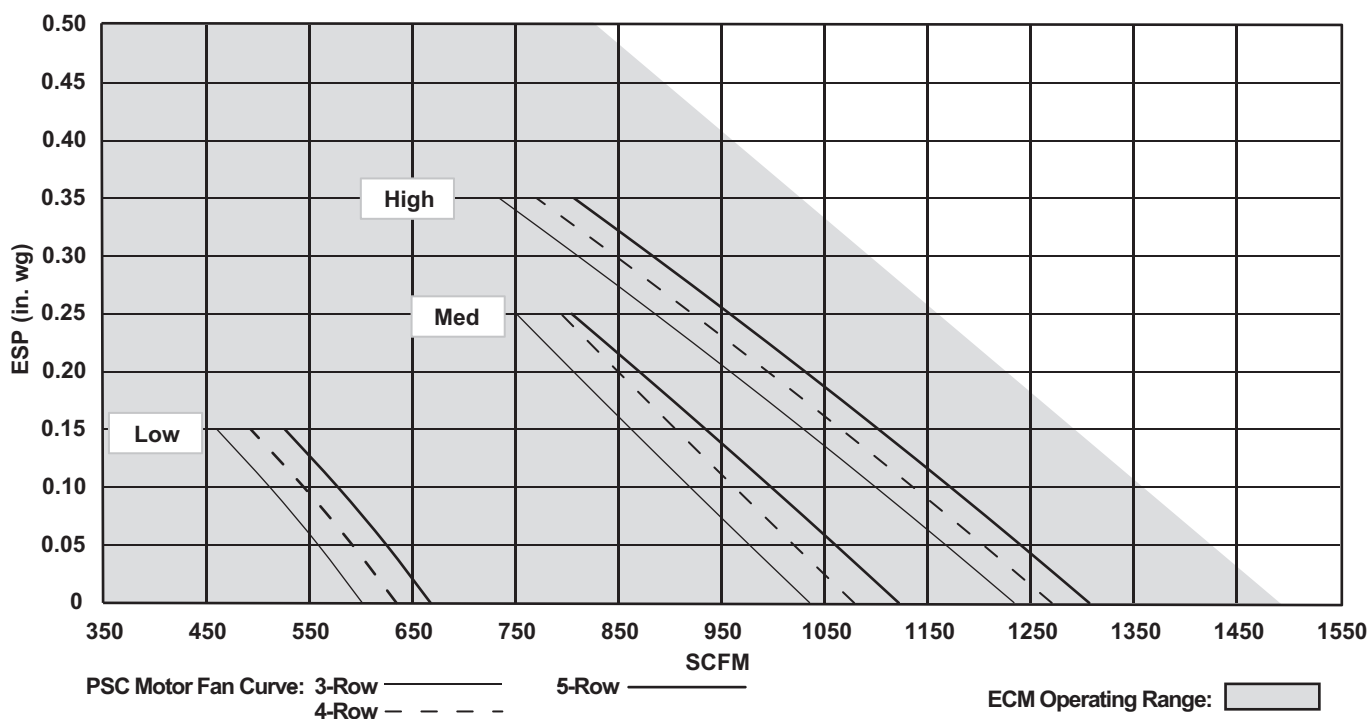

PSC Motor Fan Curve: 3-Row ——— 5-Row ———  
4-Row - - - -

ECM Operating Range:

LEGEND

- ECM — Electronically Commutated Motor
- ESP — External Static Pressure
- PSC — Permanent Split Capacitor
- SCFM — Square Cubic Feet per Minute

# Electrical data



## ELECTRIC HEATER DATA

HEATER VOLTAGE	HEATER kW									
	0.5	1.0	1.5	2.0	3.0	4.0	5.0	6.0	8.0	10.0
	FLA									
120	4.2	8.3	12.5	16.7	25.0	—	—	—	—	—
208	2.4	4.8	7.2	9.6	14.4	19.2	24.0	28.8	38.5	—
240	2.1	4.2	6.3	8.3	12.5	16.7	20.8	25.0	33.3	41.7
277	1.8	3.6	5.4	7.2	10.8	14.4	18.05	21.7	28.9	36.1

**LEGEND**

FLA — Full Load Amps

NOTE: All heaters are single-stage and single-phase.

## 42CA,CE,CG AND CK PSC MOTOR DATA

V-Ph-Hz	FAN SPEED	UNIT SIZE											
		02			03			04			06		
		Nominal Hp	Watts	Amps	Nominal Hp	Watts	Amps	Nominal Hp	Watts	Amps	Nominal Hp	Watts	Amps
115-1-60	H	1/30	78	0.53	1/30	89	0.83	1/12	144	1.40	1/12	151	1.40
	M		58	0.31		62	0.50		91	0.70		86	0.72
	L		44	0.27		47	0.34		68	0.45		60	0.45
208-1-60	H	1/30	98	0.48	1/30	99	0.48	1/12	120	0.69	1/12	132	0.69
	M		75	0.29		75	0.29		88	0.43		92	0.47
	L		49	0.15		49	0.15		54	0.22		55	0.24
230-1-60	H	1/30	114	0.48	1/30	112	0.48	1/12	137	0.69	1/12	150	0.69
	M		87	0.31		86	0.32		104	0.45		111	0.52
	L		57	0.15		57	0.15		62	0.24		65	0.28
277-1-60	H	1/30	104	0.35	1/30	112	0.35	1/12	143	0.69	1/12	155	0.69
	M		86	0.26		91	0.26		107	0.43		112	0.43
	L		55	0.16		57	0.16		65	0.25		67	0.35

V-Ph-Hz	FAN SPEED	UNIT SIZE								
		08			10*			12*		
		Nominal Hp	Watts	Amps	Nominal Hp	Watts	Amps	Nominal Hp	Watts	Amps
115-1-60	H	1/6	223	2.50	1/12 (2)	286	2.80	1/6 (2)	399	5.00
	M		166	1.50		184	1.40		307	2.80
	L		83	1.20		134	0.90		166	1.20
208-1-60	H	1/6	189	1.30	1/12 (2)	245	1.38	1/6 (2)	325	2.60
	M		109	0.69		182	0.94		208	1.33
	L		60	0.47		109	0.46		120	0.94
230-1-60	H	1/6	206	1.30	1/12 (2)	281	1.38	1/6 (2)	356	2.60
	M		128	0.70		210	1.00		241	1.34
	L		72	0.50		130	0.50		143	1.00
277-1-60	H	1/6	245	0.91	1/12 (2)	288	1.38	1/6 (2)	426	1.82
	M		152	0.62		219	0.80		293	1.20
	L		120	0.35		132	0.25		234	0.66

\*Total motor amps and watts shown for units with 2 motors.

**NOTES:**

- Motor nameplate amps may vary.
- Fan coil units comply with ETL, Canadian Standards Association (CSA), and ETL of Canada standards.



## 42C HIGH-STATIC PSC MOTOR DATA

SIZE	NOMINAL HP	AMPS	WATTS
42C*02	1/12	1.4	59
42C*03	1/12	1.4	100
42C*04	1/6	2.5	195
42C*06	1/6	2.5	195
42C*08	1/5	3.6	277
42C*10	1/6	5.0	360
42C*12	1/5	7.2	513

**NOTES:**

- High-static PSC motors are available on 42CA,CE,CK for 60 Hz voltages with a special quote.

- Motor amps and watts based on 115V motors.

### 42C ECM MOTOR DATA

SIZE	NOMINAL HP	AMPS			
		120V	208V	230V	277V
42C*02	1/7	2.4	1.4	1.3	1.2
42C*03	1/7				
42C*04	1/6				
42C*06	1/6				
42C*08	1/6				
42C*10	1/6 (2)				
42C*12	1/6 (2)			3.2	3.0

42C Series Units

# Model number nomenclature



42V Series Units

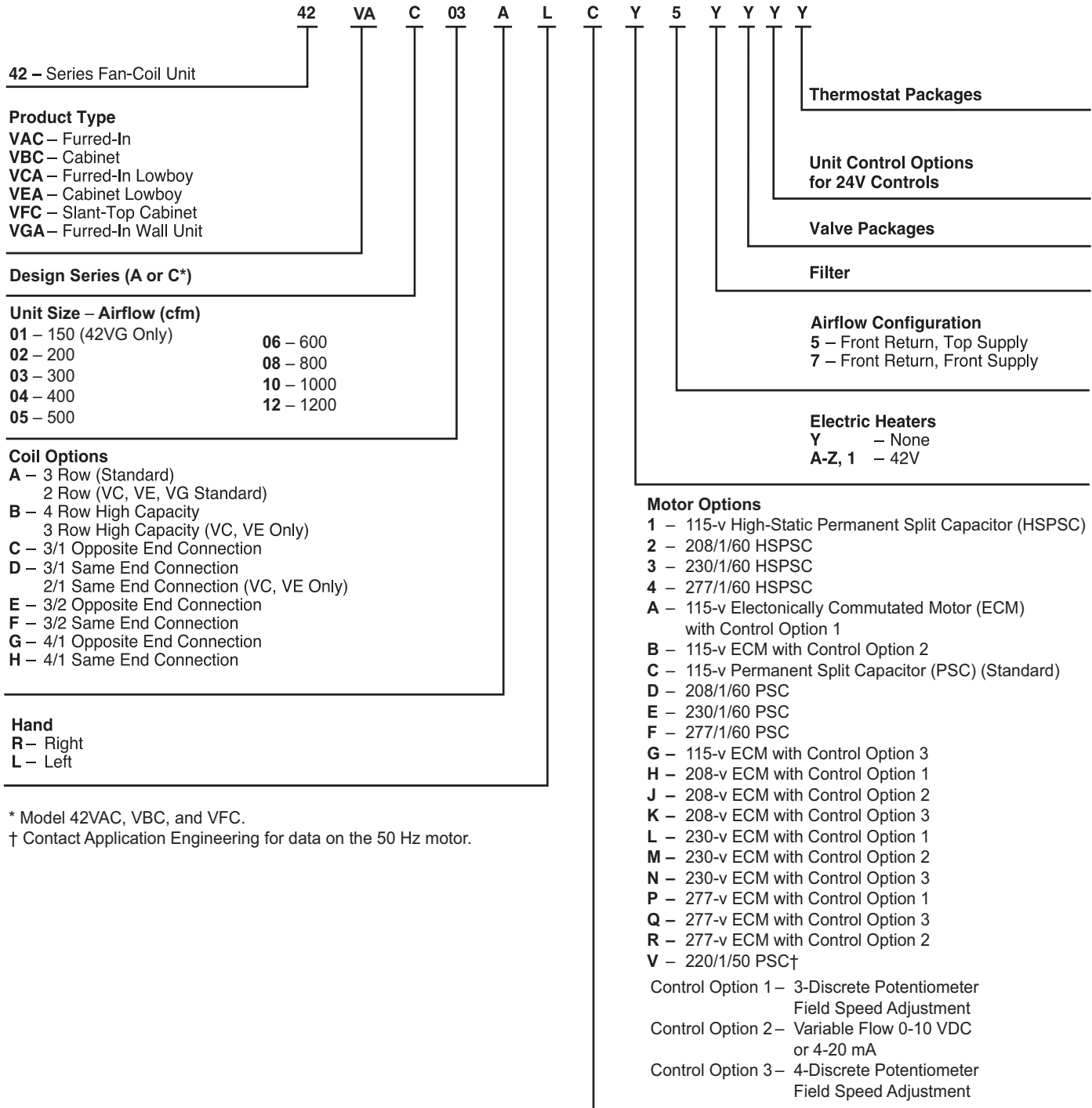

\* Model 42VAC, VBC, and VFC.  
 † Contact Application Engineering for data on the 50 Hz motor.

# AHRI capacity ratings



The 42V Series fan coil units are certified in compliance with the Air-Conditioning, Heating and Refrigeration Institute (AHRI) Industry Standard 440 for room fan coil units. Approved standard ratings are tabulated below:



## AHRI APPROVED STANDARD RATINGS\*

UNIT	UNIT SIZE	COIL ROWS	NOMINAL CFM	COOLING CAPACITY		POWER INPUT (WATTS)†
				Total MBtuh	Sensible MBtuh	
42VAC, VBC, VFC	02	3	200	6.9	4.7	65
	03		300	8.1	5.9	80
	04		400	11.6	8.8	135
	05		500	15.4	10.5	180
	06		600	18.7	13.4	190
	08		800	20.8	14.4	200
	10		1000	31.7	21.1	275
	12		1200	34.1	23.9	355
	02	4	200	8.1	5.2	65
	03		300	9.2	6.5	80
	04		400	12.7	9.1	135
	05		500	17.5	11.8	230
	06		600	20.6	14.2	190
	08		800	21.7	14.3	200
	10		1000	30.7	19.9	275
	12		1200	38.9	25.6	350
42VGA	01	2	130	1.8	1.6	135**
	03		275	5.2	4.7	270**
42VCA, VEA	02	2	200	5.1	3.6	68
	03		300	8.6	6.7	135
	04		400	12.3	8.3	150
	06		600	18.3	13.2	260
	02	3	220	5.5	3.8	72
	03		300	10.9	7.1	130
	04		400	13.4	8.8	145
	06		600	21.1	14.6	250

### LEGEND

**MBtuh** — Capacity (Btuh in thousands)

\*Ratings based on motor at high fan speed, standard air and dry coil operation, 10° F water temperature rise; entering-air temperature 67 F wb; 80 F db; entering water temperature 45 F.

†Motor type permanent split capacitor operating at 115-1-60 voltage.

\*\*Shaded pole motor.

42V Series Units

# Physical data



UNIT SIZE 42V	01	02	03	04	05	06	08	10	12
<b>NOMINAL AIRFLOW (cfm)</b>	150	200	300	400	500	600	800	1000	1200
<b>SHIPPING WEIGHT (lb)*</b>									
42VAC	—	42	47	57	60	77	79	108	127
42VBC	—	63	68	82	85	99	101	133	154
42VCA	—	50	60	72	—	110	—	—	—
42VEA	—	72	100	108	—	154	—	—	—
42VFC	—	64	69	83	86	100	102	135	156
42VGA	40	—	74	—	—	—	—	—	—
<b>COILS</b>									
FPI (42VAC, VBC, VFC)	12 fins/inch								
FPI (42VCA, VEA, VGA)	10 fins/inch								
<b>MOTOR (qty)</b>									
42VAC, VBC, VFC	—	1	1	1	1	1	1	2	2
42VCA, VEA	—	1	1	1	—	2	—	—	—
42VGA	1	—	2	—	—	—	—	—	—
<b>BLOWER (qty)</b>									
42VAC, VBC, VFC	—	1	1	2	2	2	2	4	4
42VCA, VEA	—	2	2	2	—	4	—	—	—
42VGA	1	—	2	—	—	—	—	—	—
<b>FILTERS</b>									
Nominal Size (in.) (1-in. thick)									
42VAC, VBC, VFC	—	7 <sup>3</sup> / <sub>4</sub> x 21 <sup>3</sup> / <sub>4</sub>	7 <sup>3</sup> / <sub>4</sub> x 21 <sup>3</sup> / <sub>4</sub>	7 <sup>3</sup> / <sub>4</sub> x 31 <sup>3</sup> / <sub>4</sub>	7 <sup>3</sup> / <sub>4</sub> x 31 <sup>3</sup> / <sub>4</sub>	7 <sup>3</sup> / <sub>4</sub> x 41 <sup>3</sup> / <sub>4</sub>	7 <sup>3</sup> / <sub>4</sub> x 43 <sup>3</sup> / <sub>4</sub>	7 <sup>3</sup> / <sub>4</sub> x 57 <sup>3</sup> / <sub>4</sub>	7 <sup>3</sup> / <sub>4</sub> x 65 <sup>3</sup> / <sub>4</sub>
42VCA, VEA	—	7 x 21 <sup>3</sup> / <sub>4</sub>	7 x 26 <sup>3</sup> / <sub>4</sub>	7 x 34 <sup>3</sup> / <sub>4</sub>	—	7 x 48 <sup>3</sup> / <sub>4</sub>	—	—	—
42VGA	10 x 14 <sup>1</sup> / <sub>2</sub>	—	10 x 28	—	—	—	—	—	—
Qty	1	1	1	1	1	1	1	1	1
<b>SUPPLY DUCT COLLAR</b>	1-in.								
<b>PIPING CONNECTIONS (Sweat) (in.)</b>									
Coil Outlet and Inlet	5/8 OD								
Drain Connection	3/4 MPT								

\*Calculate operating weight of unit: shipping weight + coil water weight x number of coil rows.

# Base unit dimensions



## 42VAC FURRED-IN VERTICAL UNIT

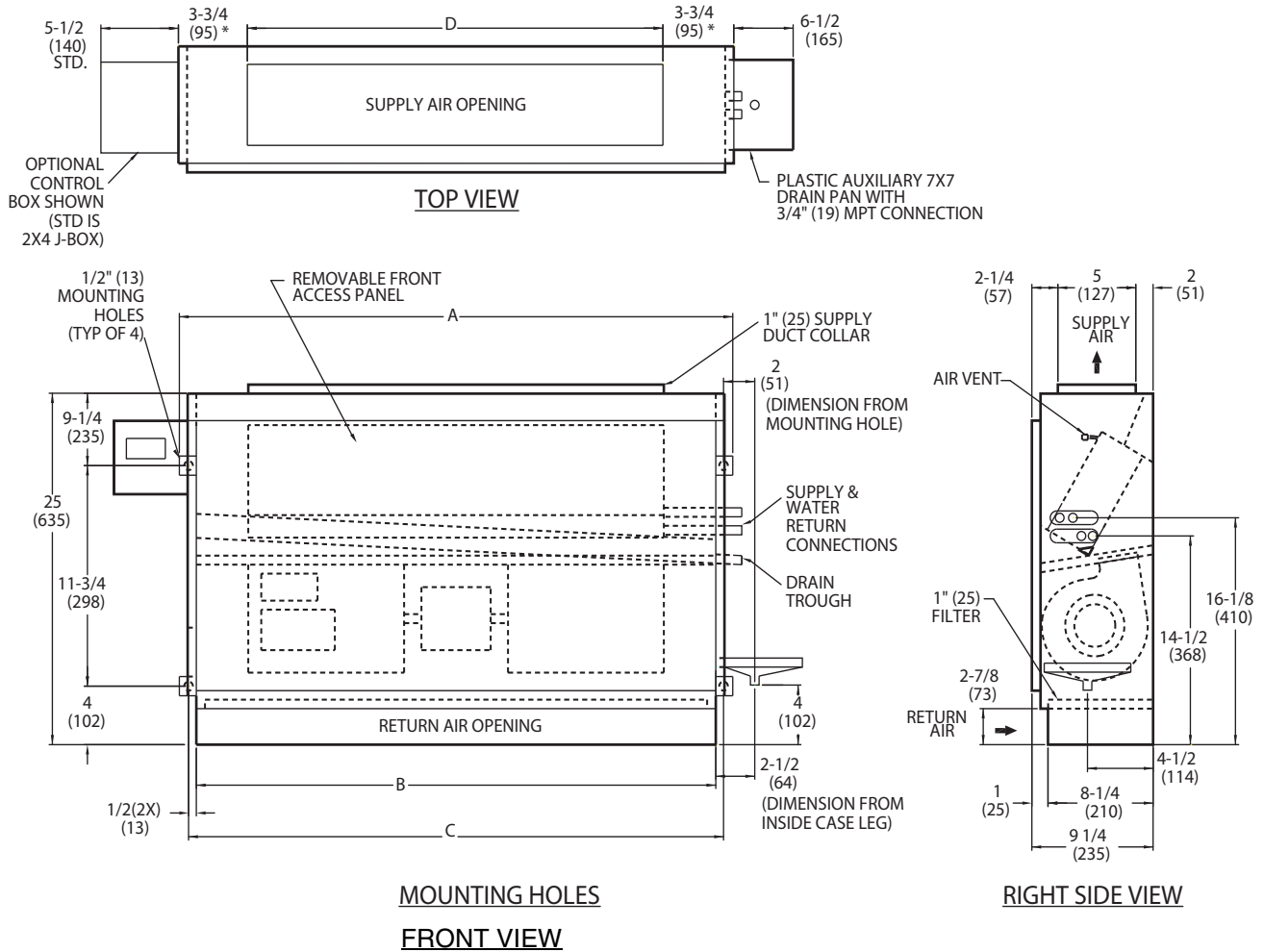

- NOTES:
1. All dimensions are  $\pm 1/4$ -in. (6).
  2. Standard 3-row coil shown.
  3. Right hand unit shown, left hand unit is opposite.
  4. Dimensions shown in inches (mm).

UNIT SIZE	DIMENSIONS (in.)				QTY/UNIT		UNIT WEIGHT* (lb)
	A	B	C	D	Blower	Motor	
02	24 <sup>3</sup> / <sub>16</sub>	22	23	16	1	1	42
03	24 <sup>3</sup> / <sub>16</sub>	22	23	18	1	1	47
04	34 <sup>3</sup> / <sub>16</sub>	32	33	26	2	1	57
05	34 <sup>3</sup> / <sub>16</sub>	32	33	26	2	1	60
06	44 <sup>3</sup> / <sub>16</sub>	42	43	36	2	1	77
08	46 <sup>3</sup> / <sub>16</sub>	44	45	38	2	1	79
10	60 <sup>3</sup> / <sub>16</sub>	58	59	52	4	2	108
12	68 <sup>3</sup> / <sub>16</sub>	66	67	60	4	2	127

\*Unit weights are based on dry coils and minimum rows. Weights exclude packaging, valves, and other components.

42V Series Units

# Base unit dimensions (cont)



## 42VAC FURRED-IN VERTICAL UNIT WITH ELECTRIC HEATER AND TOP SUPPLY

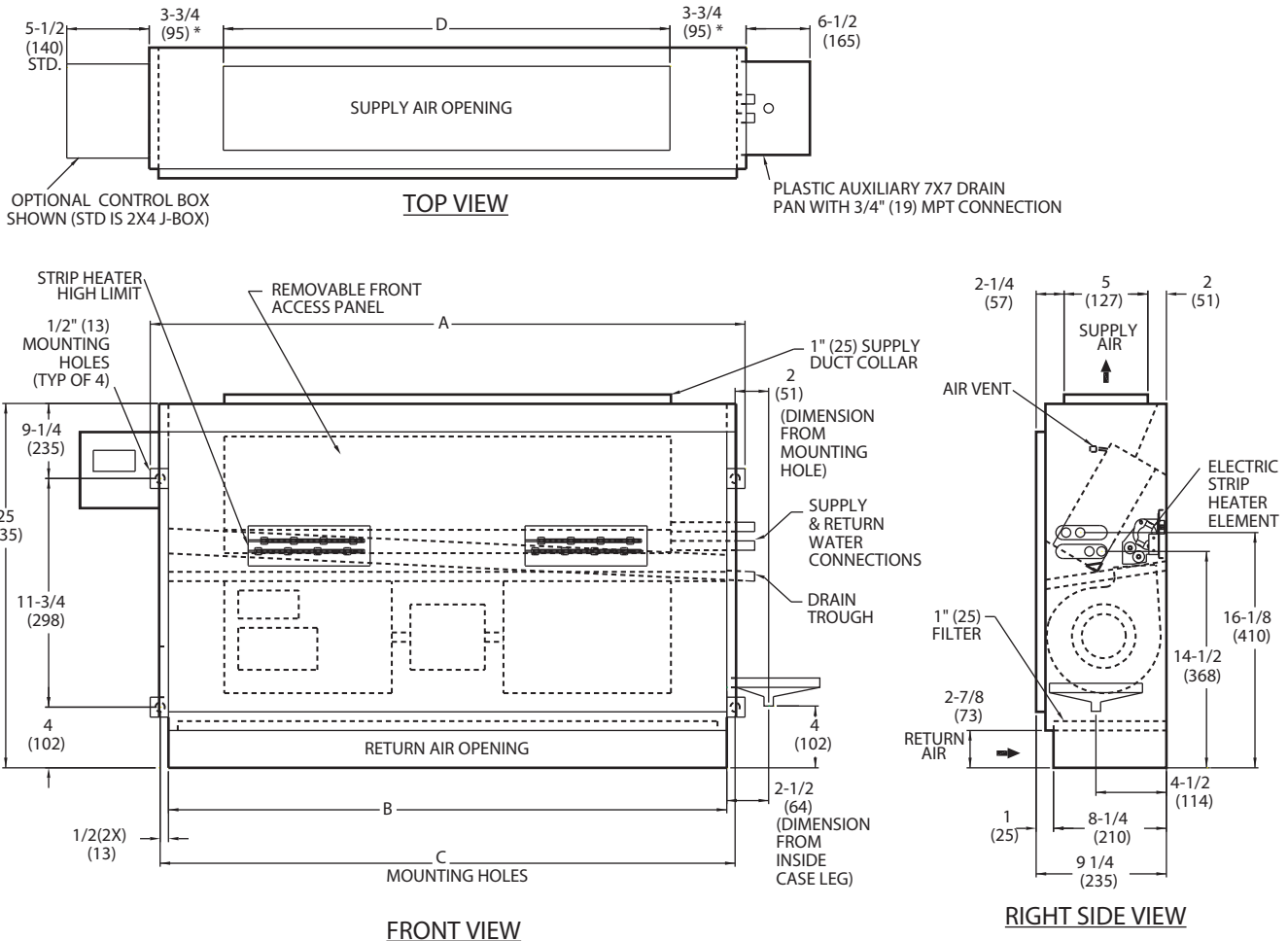

- NOTES:
1. All dimensions are  $\pm 1/4$ -in. (6).
  2. Standard 3-row coil shown.
  3. Right hand unit shown, left hand unit is opposite.
  4. Dimensions shown in inches (mm).

UNIT SIZE	DIMENSIONS (in.)				QTY/UNIT		UNIT WEIGHT* (lb)
	A	B	C	D	Blower	Motor	
02	24 <sup>3</sup> / <sub>16</sub>	22	23	16	1	1	44
03	24 <sup>3</sup> / <sub>16</sub>	22	23	18	1	1	49
04	34 <sup>3</sup> / <sub>16</sub>	32	33	26	2	1	59
05	34 <sup>3</sup> / <sub>16</sub>	32	33	26	2	1	62
06	44 <sup>3</sup> / <sub>16</sub>	42	43	36	2	1	80
08	46 <sup>3</sup> / <sub>16</sub>	44	45	38	2	1	82
10	60 <sup>3</sup> / <sub>16</sub>	58	59	52	4	2	111
12	68 <sup>3</sup> / <sub>16</sub>	66	67	60	4	2	130

\*Unit weights are based on dry coils and minimum rows. Weights exclude packaging, valves, and other components.

42V Series Units



### 42VAC FURRED-IN VERTICAL UNIT WITH ELECTRIC HEATER AND FRONT SUPPLY

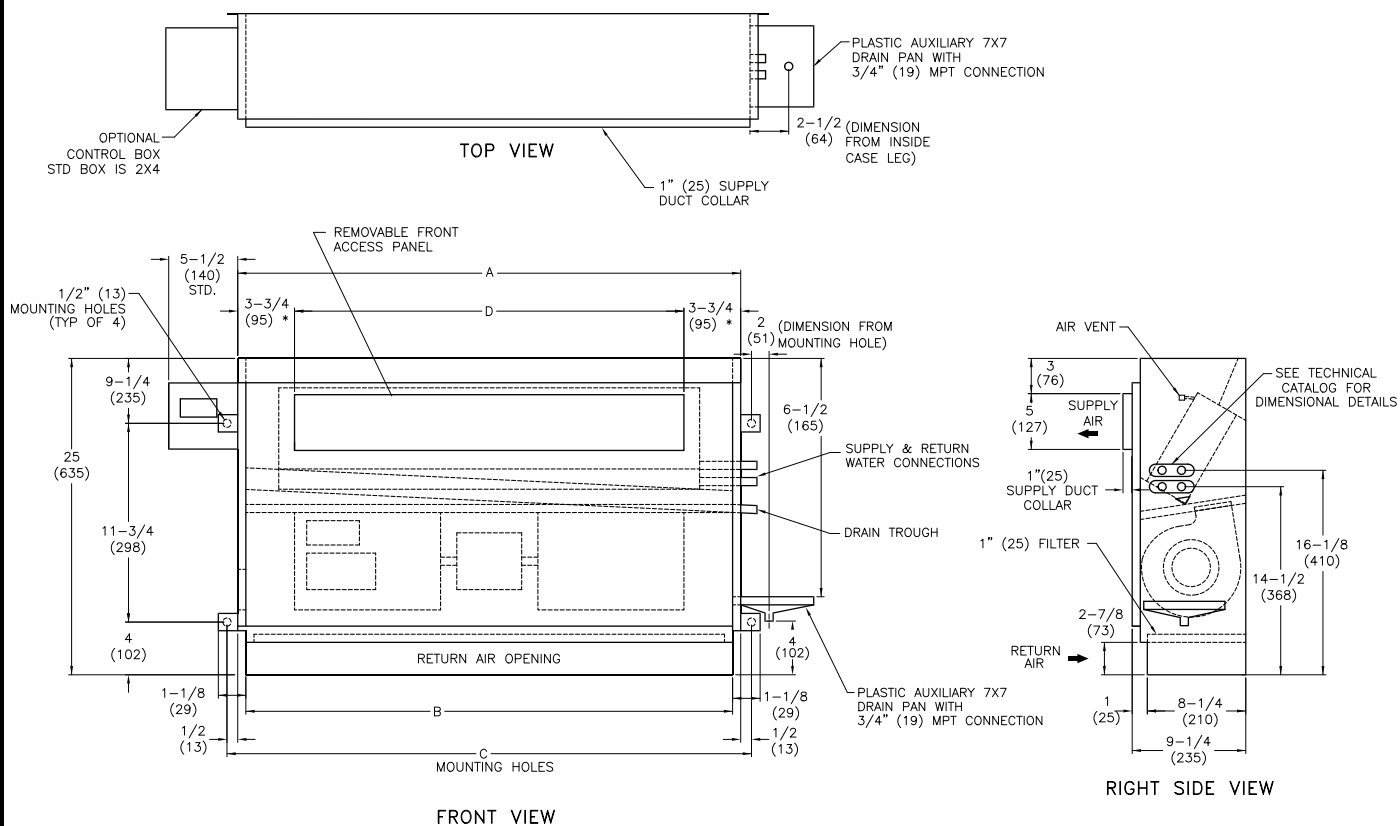

- NOTES:**
1. All dimensions are  $\pm 1/4$ -in. (6).
  2. Standard 3-row coil shown.
  3. Right hand unit shown, left hand unit is opposite.
  4. Dimensions shown in inches (mm).

UNIT SIZE	DIMENSIONS (in.)				QTY/UNIT		UNIT WEIGHT* (lb)
	A	B	C	D	Blower	Motor	
02	24 <sup>3</sup> / <sub>16</sub>	22	23	16	1	1	44
03	24 <sup>3</sup> / <sub>16</sub>	22	23	18	1	1	49
04	34 <sup>3</sup> / <sub>16</sub>	32	33	26	2	1	59
05	34 <sup>3</sup> / <sub>16</sub>	32	33	26	2	1	62
06	44 <sup>3</sup> / <sub>16</sub>	42	43	36	2	1	80
08	46 <sup>3</sup> / <sub>16</sub>	44	45	38	2	1	82
10	60 <sup>3</sup> / <sub>16</sub>	58	59	52	4	2	111
12	68 <sup>3</sup> / <sub>16</sub>	66	67	60	4	2	130

\*Unit weights are based on dry coils and minimum rows. Weights exclude packaging, valves, and other components.

# Base unit dimensions (cont)

## 42VBC VERTICAL CABINET UNIT WITH TOP SUPPLY

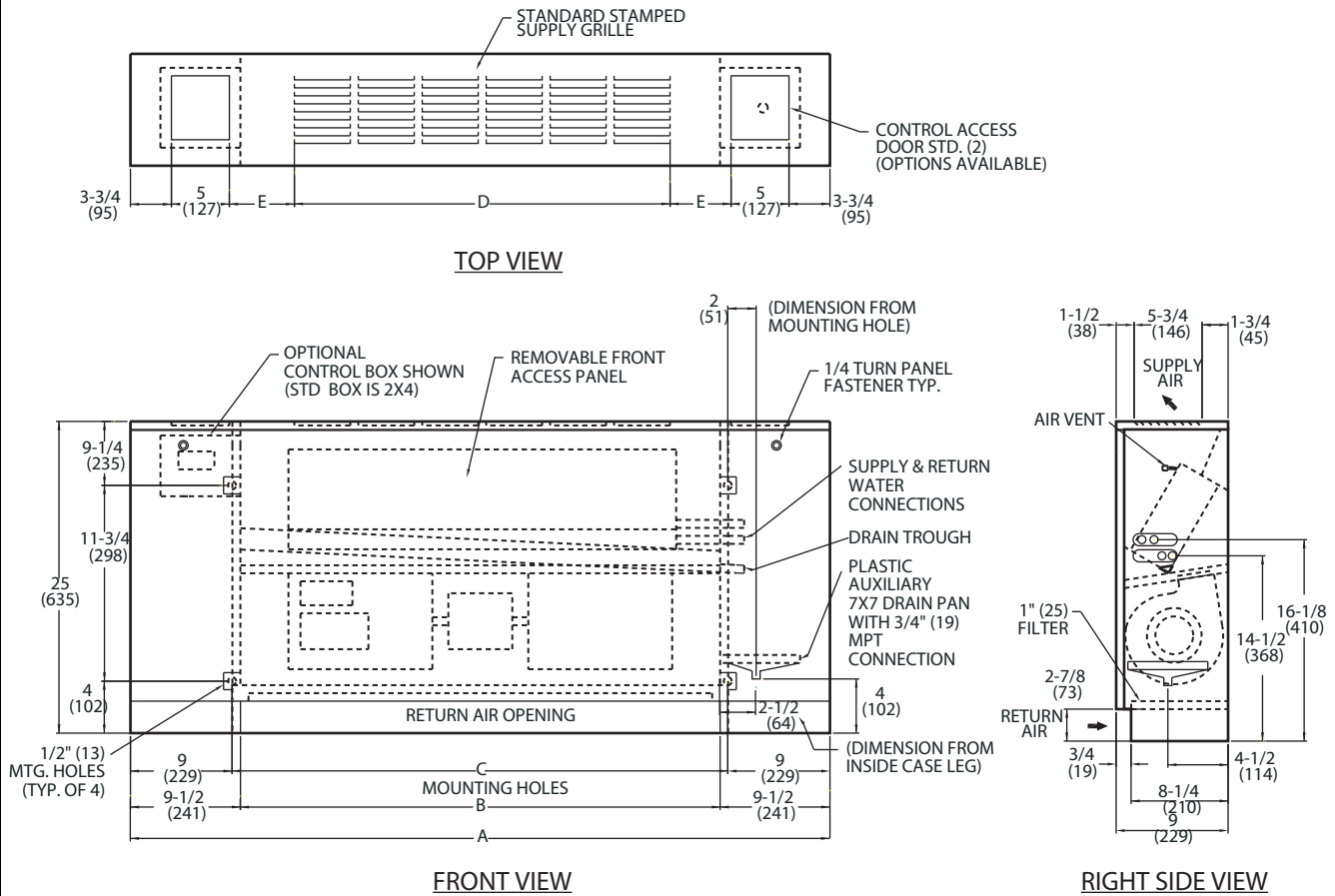

### NOTES:

1. All dimensions are  $\pm 1/4$ -in. (6).
2. Standard 3-row coil shown.
3. Right hand unit shown, left hand unit is opposite.
4. Dimensions shown in inches (mm).

UNIT SIZE	DIMENSIONS (in.)					QTY/UNIT		UNIT WEIGHT* (lb)
	A	B	C	D	E	Blower	Motor	
02	41	22	23	17 1/4	3 1/8	1	1	63
03	41	22	23	17 1/4	3 1/8	1	1	68
04	51	32	33	26	3 3/4	2	1	82
05	51	32	33	26	3 3/4	2	1	85
06	61	42	43	39	2 1/4	2	1	99
08	63	44	45	39	3 1/4	2	1	101
10	77	58	59	52 1/8	3 5/8	4	2	133
12	85	66	67	61	3 1/4	4	2	154

\*Unit weights are based on dry coils and minimum rows. Weights exclude packaging, valves, and other components.

### 42VBC VERTICAL CABINET UNIT WITH ELECTRIC HEATER WITH TOP SUPPLY

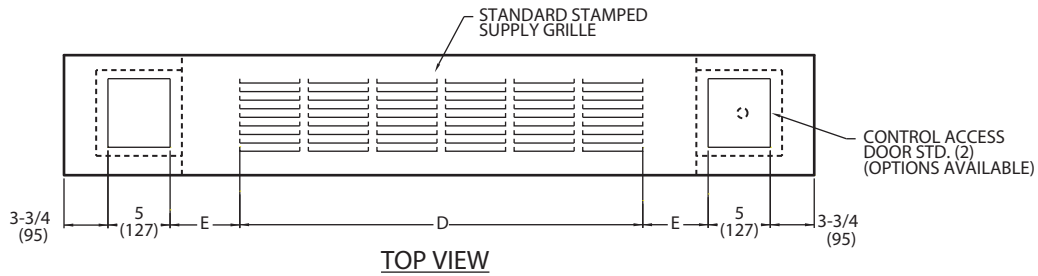

TOP VIEW

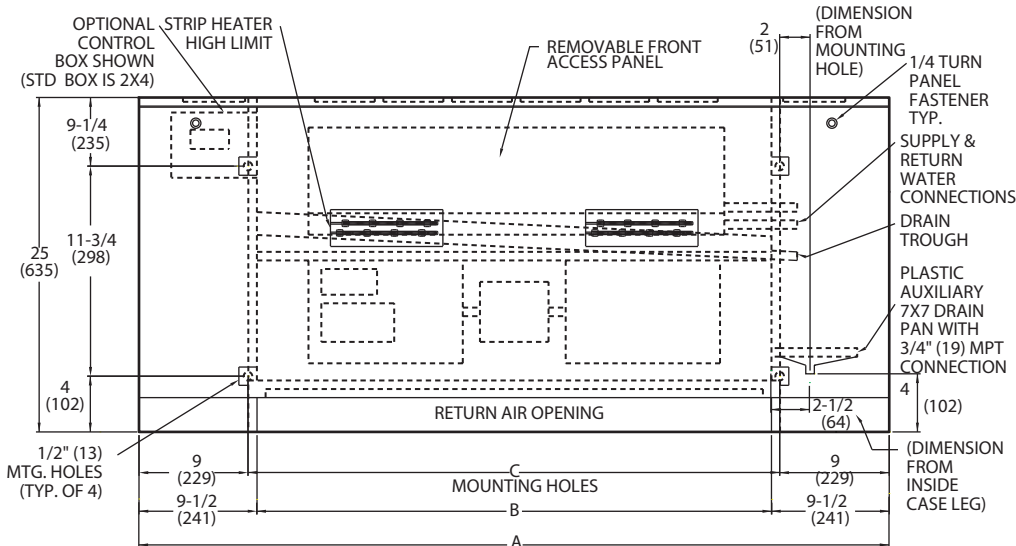

FRONT VIEW

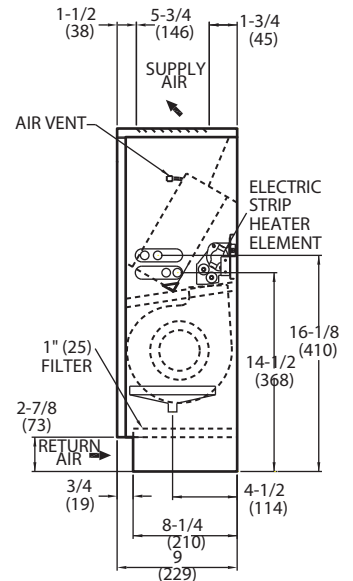

RIGHT SIDE VIEW

- NOTES:
1. All dimensions are  $\pm 1/4$ -in. (6).
  2. Standard 3-row coil shown.
  3. Right hand unit shown, left hand unit is opposite.
  4. Dimensions shown in inches (mm).

UNIT SIZE	DIMENSIONS (in.)					QTY/UNIT		UNIT WEIGHT* (lb)
	A	B	C	D	E	Blower	Motor	
02	41	22	23	17 1/4	3 1/8	1	1	65
03	41	22	23	17 1/4	3 1/8	1	1	70
04	51	32	33	26	3 3/4	2	1	84
05	51	32	33	26	3 3/4	2	1	87
06	61	42	43	39	2 1/4	2	1	102
08	63	44	45	39	3 1/4	2	1	104
10	77	58	59	52 1/8	3 5/8	4	2	136
12	85	66	67	61	3 1/4	4	2	157

\*Unit weights are based on dry coils and minimum rows. Weights exclude packaging, valves, and other components.

# Base unit dimensions (cont)

42V Series Units

## 42VBC VERTICAL CABINET UNIT WITH ELECTRIC HEATER WITH FRONT SUPPLY

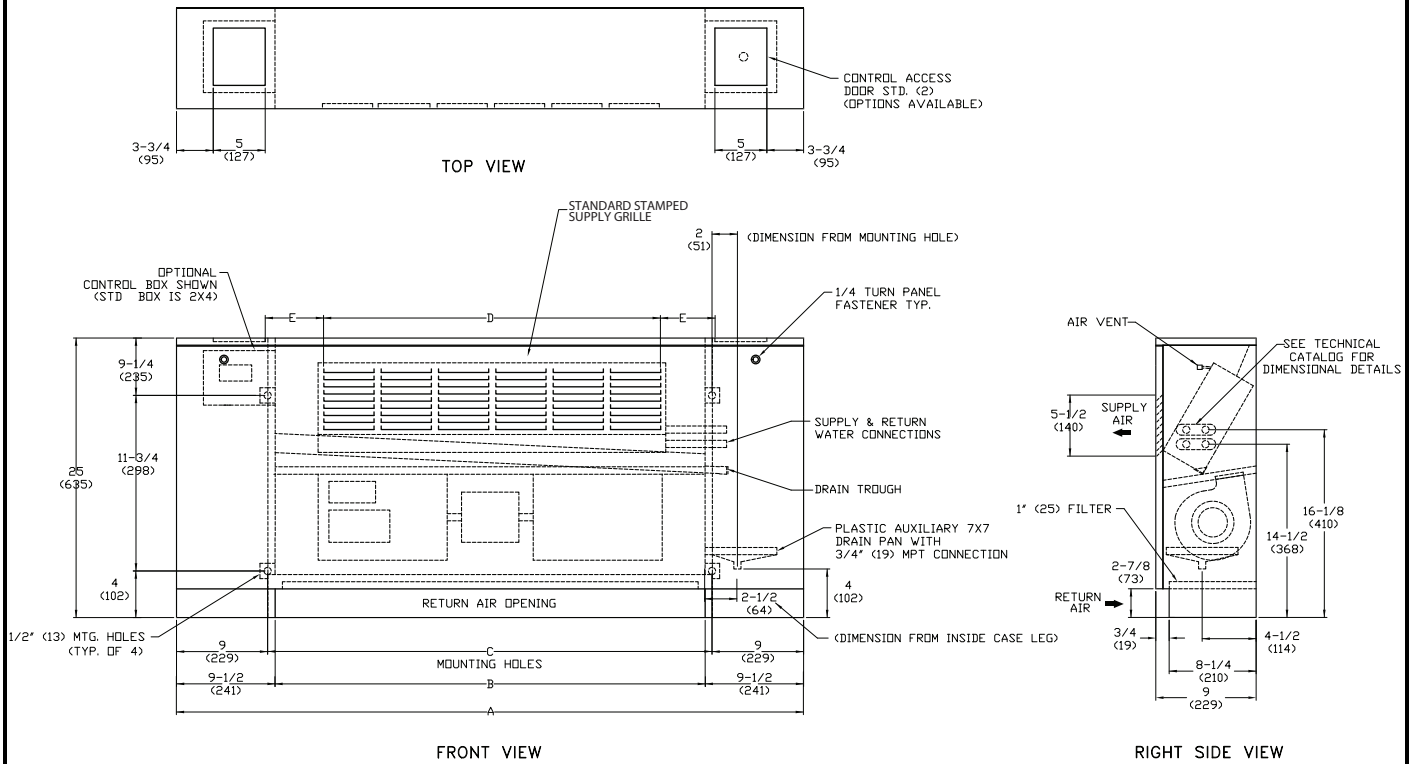

**NOTES:**

1. All dimensions are ± 1/4-in. (6).
2. Standard 3-row coil shown.
3. Right hand unit shown, left hand unit is opposite.
4. Dimensions shown in inches (mm).

UNIT SIZE	DIMENSIONS (in.)					QTY/UNIT		UNIT WEIGHT* (lb)
	A	B	C	D	E	Blower	Motor	
02	41	22	23	17 1/4	3 1/8	1	1	65
03	41	22	23	17 1/4	3 1/8	1	1	70
04	51	32	33	26	3 3/4	2	1	84
05	51	32	33	26	3 3/4	2	1	87
06	61	42	43	39	2 1/4	2	1	102
08	63	44	45	39	3 1/4	2	1	104
10	77	58	59	52 1/8	3 5/8	4	2	136
12	85	66	67	61	3 1/4	4	2	157

\*Unit weights are based on dry coils and minimum rows. Weights exclude packaging, valves, and other components.

### 42VFC VERTICAL CABINET UNIT WITH SLANT TOP

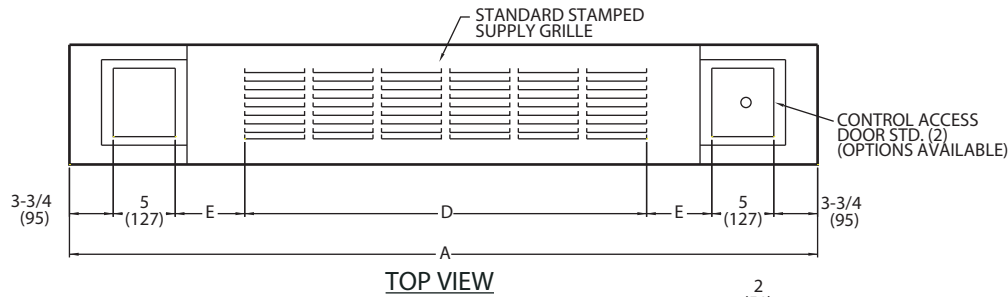

TOP VIEW

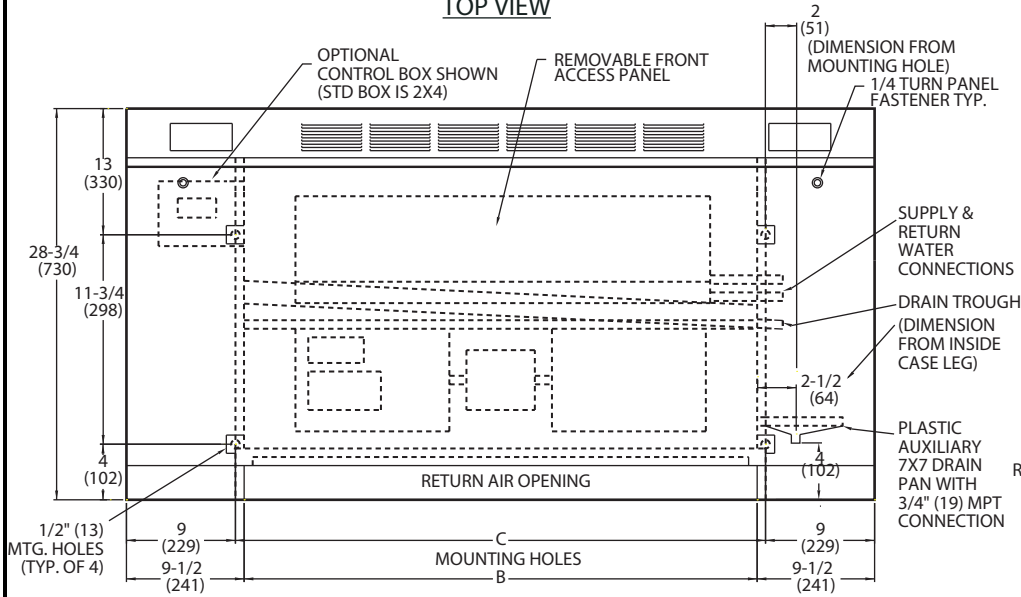

FRONT VIEW

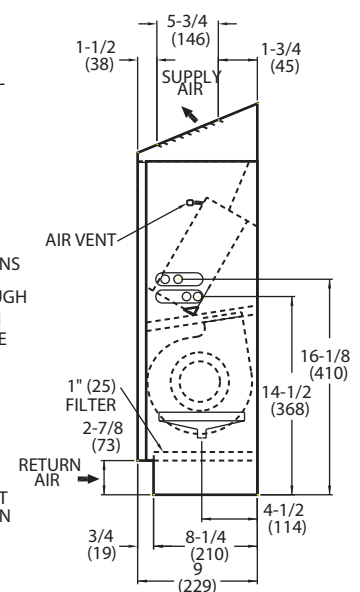

RIGHT SIDE VIEW

- NOTES:
1. All dimensions are  $\pm 1/4$ -in. (6).
  2. Standard 3-row coil shown.
  3. Right hand unit shown, left hand unit is opposite.
  4. Dimensions shown in inches (mm).

UNIT SIZE	DIMENSIONS (in.)					QTY/UNIT		UNIT WEIGHT* (lb)
	A	B	C	D	E	Blower	Motor	
02	41	22	23	17 1/4	3 1/8	1	1	64
03	41	22	23	17 1/4	3 1/8	1	1	69
04	51	32	33	26	3 3/4	2	1	83
05	51	32	33	26	3 3/4	2	1	86
06	61	42	43	39	2 1/4	2	1	100
08	63	44	45	39	3 1/4	2	1	102
10	77	58	59	52 1/8	3 5/8	4	2	135
12	85	66	67	61	3 1/4	4	2	156

\*Unit weights are based on dry coils and minimum rows. Weights exclude packaging, valves, and other components.

42V Series Units

# Base unit dimensions (cont)

## 42VFC VERTICAL CABINET UNIT WITH SLANT TOP AND ELECTRIC HEATER

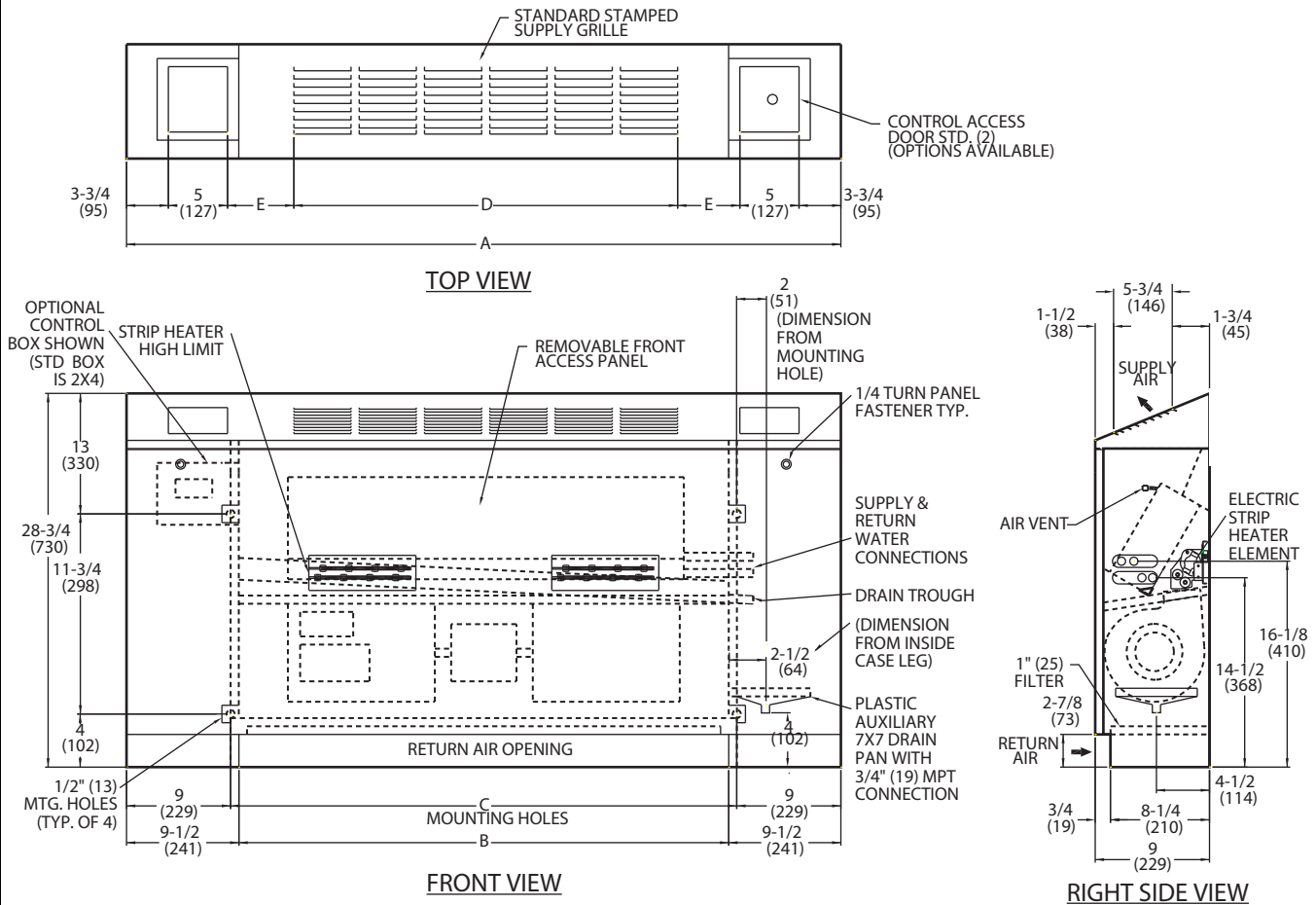

- NOTES:**
1. All dimensions are  $\pm 1/4$ -in. (6).
  2. Standard 3-row coil shown.
  3. Right hand unit shown, left hand unit is opposite.
  4. Dimensions shown in inches (mm).

UNIT SIZE	DIMENSIONS (in.)					QTY/UNIT		UNIT WEIGHT* (lb)
	A	B	C	D	E	Blower	Motor	
02	41	22	23	17 1/4	3 1/8	1	1	66
03	41	22	23	17 1/4	3 1/8	1	1	71
04	51	32	33	26	3 3/4	2	1	85
05	51	32	33	26	3 3/4	2	1	88
06	61	42	43	39	2 1/4	2	1	103
08	63	44	45	39	3 1/4	2	1	105
10	77	58	59	52 1/8	3 5/8	4	2	138
12	85	66	67	61	3 1/4	4	2	159

\*Unit weights are based on dry coils and minimum rows. Weights exclude packaging, valves, and other components.

### 42VCA FURRED-IN LOWBOY UNIT

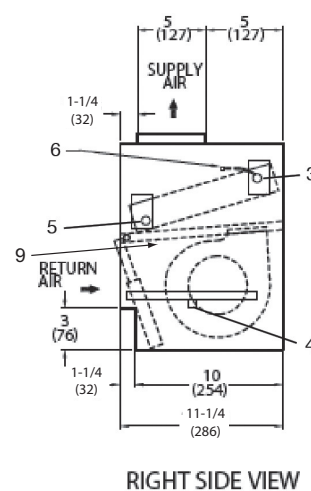
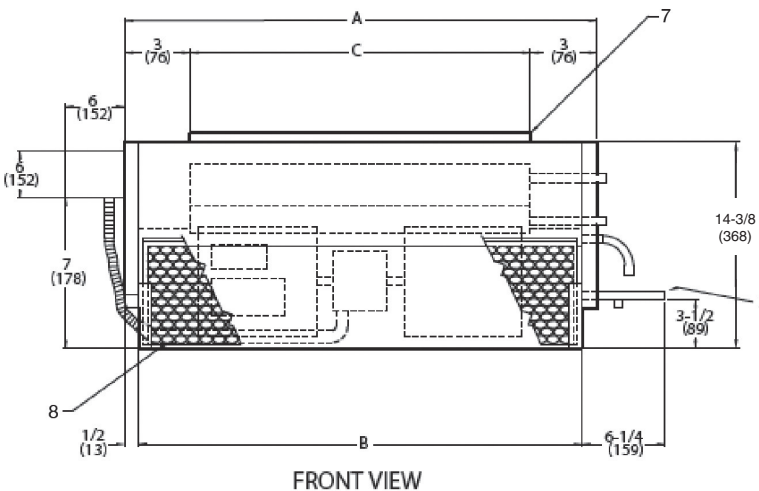
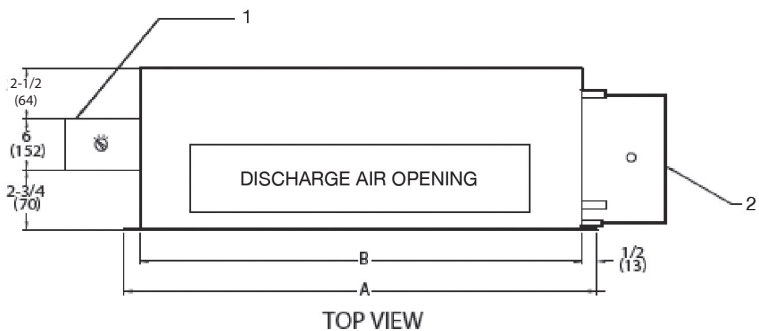

#### LEGEND

- 1 — Optional Unit Mounted Control Box
- 2 — Drain Pan, Auxiliary, Shipped Loose
- 3 — Supply Conn, 5/8-in. OD
- 4 — Drain, 3/4-in. MPT
- 5 — Return Conn, 5/8-in. OD
- 6 — Air Vent, 1/8-in. MPT
- 7 — Discharge Opening
- 8 — Filter
- 9 — Drain Pan

#### NOTES:

1. Right hand unit shown; left hand unit opposite. Coil connection locations are  $\pm 5/8$ -inches.
2. Unit sizes 02 through 04 have one motor, 2 blowers; size 06 has 2 motors, 4 blowers.
3. Standard 2-row coil shown.
4. Optional unit-mounted switch box and controls, when specified, are installed on opposite side from cooling connections.
5. Height increases by 2 in. with electric heat.
6. Not shown: 3-speed fan switch, 1/2-in. fiberglass insulation on inside of casing, closed cell foam on main drain pan.
7. Units have galvanized finish.
8. See 42VCA-203-1 for optional coil connections.
9. Dimensions shown in inches (mm).

UNIT SIZE	NOM AIRFLOW (Cfm)	DIMENSIONS (in.)			QTY/UNIT		UNIT WEIGHT* (lb)
		A	B	C	Blower	Motor	
02	200	23	22	17	2	1	50
03	300	28	27	22	2	1	60
04	400	36	35	30	2	1	72
06	600	50	49	44	4	2	110

\*Unit weights are based on dry coils and minimum rows. Weights exclude packaging, valves, and other components.

42V Series Units

# Base unit dimensions (cont)

## 42VCA FURRED-IN LOWBOY UNIT WITH ELECTRIC HEAT

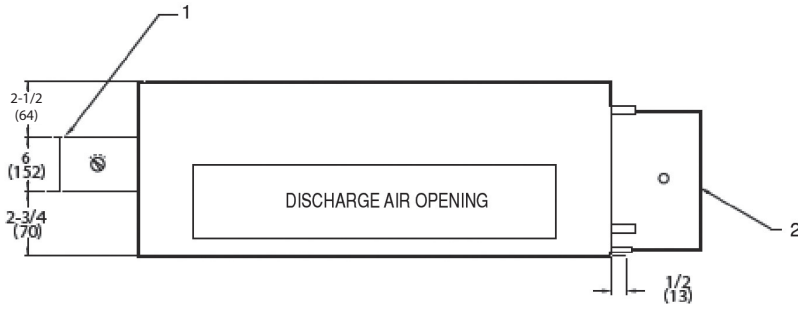

TOP VIEW

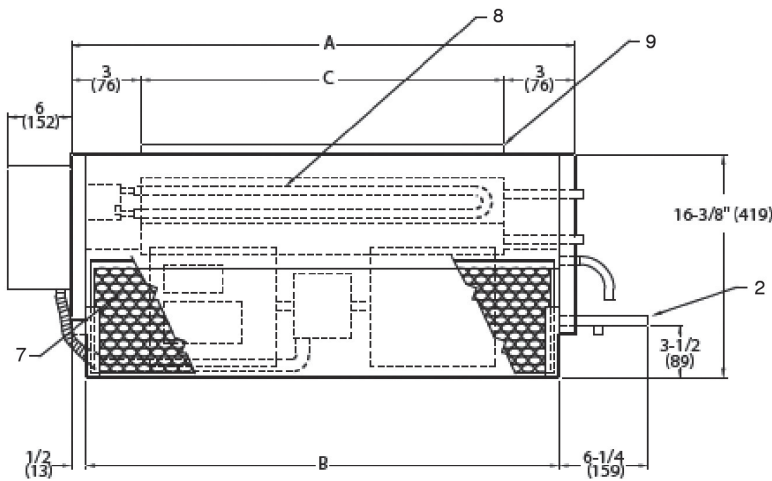

FRONT VIEW

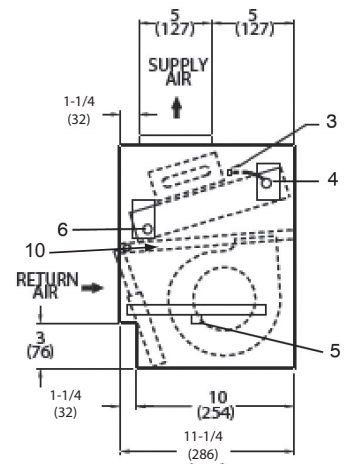

RIGHT SIDE VIEW

**LEGEND**

- 1 — Unit-Mounted Control Box (Optional)
- 2 — Drain Pan, Auxiliary, Shipped Loose
- 3 — Air Vent, 1/8-in. MPT
- 4 — Supply Conn, 5/8-in. OD
- 5 — Drain, 3/4-in. MPT
- 6 — Return Conn, 5/8-in. OD
- 7 — Filter
- 8 — Electrical Sheath Heater Element
- 9 — Discharge Opening
- 10 — Drain Pan

**NOTES:**

- 1. Right hand unit shown; left hand unit opposite. Coil connection locations are  $\pm 5/8$ -inches.
- 2. Unit sizes 02 through 04 have one motor, 2 blowers; size 06 has 2 motors, 4 blowers.
- 3. Standard 2-row coil shown.
- 4. Optional unit-mounted switch box and controls, when specified, are installed on opposite side from cooling connections.
- 5. Height increases by 2 in. with electric heat.
- 6. Not shown: 3-speed fan switch, 1/2-in. fiberglass insulation on inside of casing, closed cell foam on main drain pan.
- 7. Units have galvanized finish.
- 8. See 42VCA-203-1 for optional coil connections.
- 9. Dimensions shown in inches (mm).

UNIT SIZE	NOM AIRFLOW (Cfm)	DIMENSIONS (in.)			QTY/UNIT		UNIT WEIGHT* (lb)
		A	B	C	Blower	Motor	
02	200	23	22	17	2	1	50
03	300	28	27	22	2	1	60
04	400	36	35	30	2	1	72
06	600	50	49	44	4	2	110

\*Unit weights are based on dry coils and minimum rows. Weights exclude packaging, valves, and other components.

42V Series Units



### 42VEA CABINET LOWBOY UNIT

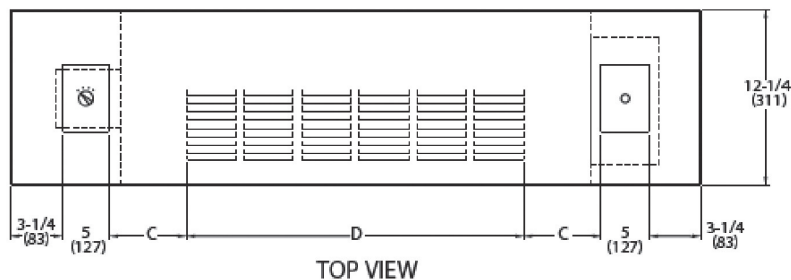

TOP VIEW

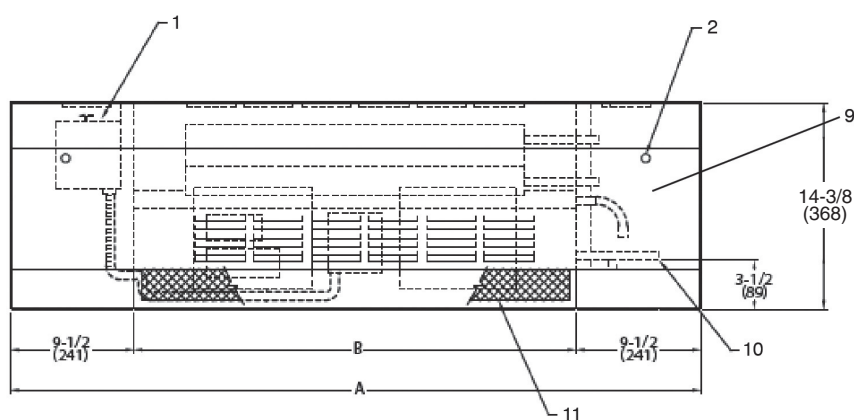

FRONT VIEW

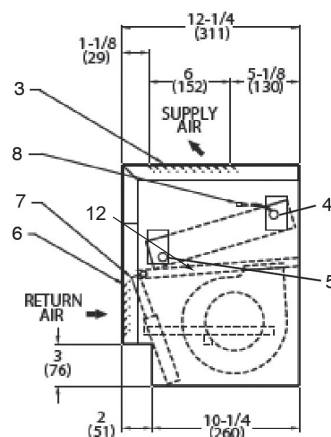

RIGHT SIDE VIEW

**LEGEND**

- 1 — Fan Switch, 3-Speed, behind Access Door
- 2 — Front Panel Fastener
- 3 — Stamped Supply Grille
- 4 — Supply Conn, 5/8-in. OD
- 5 — Return Conn, 5/8-in. OD
- 6 — Stamped Return Grille
- 7 — Filter
- 8 — Air Vent, 1/8-in. MPT
- 9 — Optional Valve Package (inside cabinet)
- 10 — Drain Pan, Auxiliary, with 3/4-in. MPT Drain Connection
- 11 — Return Air Grille
- 12 — Drain Pan

**NOTES:**

- 1. Right hand unit shown; left hand unit opposite. Coil connection locations are  $\pm 5/8$ -inches.
- 2. Unit sizes 02 through 04 have one motor, 2 blowers; size 06 has 2 motors, 4 blowers.
- 3. Cabinet has an Arctic White baked finish.
- 4. Height increases by 2 in. with electric heat.
- 5. Standard 2-row coil shown.
- 6. Not shown: 1/2-in. fiberglass insulation on inside of casing, closed cell foam on main drain pan.
- 7. See 42VCA-203-1 for optional coil connections.
- 8. Valve package is factory-installed inside the cabinet when ordered with the unit (based on component size).
- 9. Dimensions shown in inches (mm).

UNIT SIZE	NOM AIRFLOW (Cfm)	DIMENSIONS (in.)				QTY/UNIT		UNIT WEIGHT* (lb)
		A	B	C	D	Blower	Motor	
02	200	41	22	3 <sup>3</sup> / <sub>4</sub>	17	2	1	72
03	300	46	27	4	21 <sup>1</sup> / <sub>2</sub>	2	1	100
04	400	54	35	3 <sup>5</sup> / <sub>8</sub>	30 <sup>1</sup> / <sub>4</sub>	2	1	108
06	600	68	49	4 <sup>1</sup> / <sub>16</sub>	43 <sup>3</sup> / <sub>8</sub>	4	2	154

\*Unit weights are based on dry coils and minimum rows. Weights exclude packaging, valves, and other components.

42V Series Units

# Base unit dimensions (cont)

## 42VEA CABINET LOWBOY UNIT WITH ELECTRIC HEAT

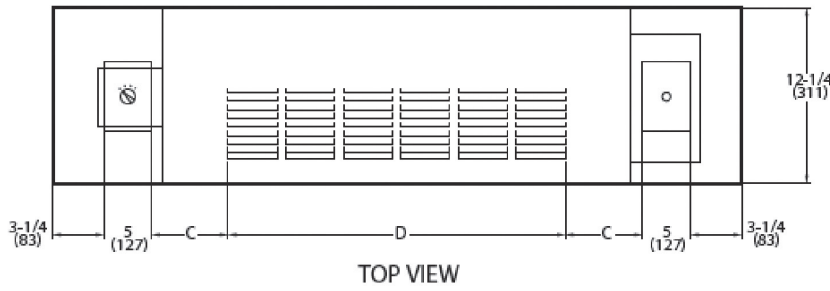

TOP VIEW

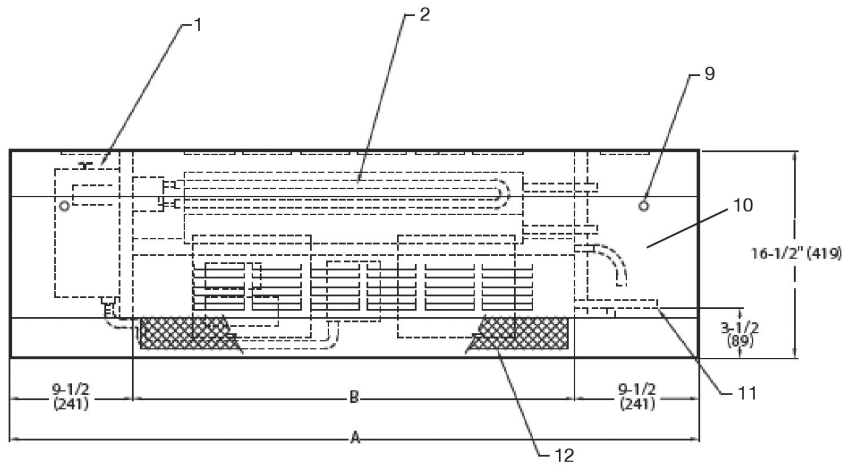

FRONT VIEW

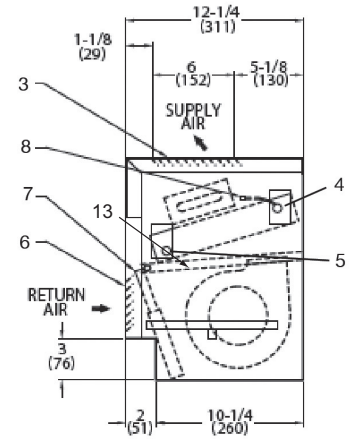

RIGHT SIDE VIEW

**LEGEND**

- 1 — Fan Switch, 3-Speed, behind Access Door
- 2 — Electrical Sheath Heater Element
- 3 — Stamped Supply Grille
- 4 — Supply Conn, 5/8-in. OD
- 5 — Return Conn, 5/8-in. OD
- 6 — Stamped Return Grille
- 7 — Filter
- 8 — Air Vent, 1/8-in. MPT
- 9 — Front Panel Fastener
- 10 — Optional Valve Package (inside cabinet)
- 11 — Drain Pan, Auxiliary, with 3/4-in. MPT Drain Connection
- 12 — Return Air Grille
- 13 — Drain Pan

**NOTES:**

- 1. Right hand unit shown; left hand unit opposite. Coil connection locations are  $\pm 5/8$ -inches.
- 2. Unit sizes 02 through 04 have one motor, 2 blowers; size 06 has 2 motors, 4 blowers.
- 3. Cabinet has an Arctic White baked finish.
- 4. Height increases by 2 in. with electric heat.
- 5. Standard 2-row coil shown.
- 6. Not shown: 1/2-in. fiberglass insulation on inside of casing, closed cell foam on main drain pan.
- 7. See 42VCA-203-1 for optional coil connections.
- 8. Valve package is factory-installed inside the cabinet when ordered with the unit (based on component size).
- 9. Dimensions shown in inches (mm).

UNIT SIZE	NOM AIRFLOW (Cfm)	DIMENSIONS (in.)				QTY/UNIT		UNIT WEIGHT* (lb)
		A	B	C	D	Blower	Motor	
02	200	41	22	3 <sup>3</sup> / <sub>4</sub>	17	2	1	72
03	300	46	27	4	21 <sup>1</sup> / <sub>2</sub>	2	1	100
04	400	54	35	3 <sup>5</sup> / <sub>8</sub>	30 <sup>1</sup> / <sub>4</sub>	2	1	108
06	600	68	49	4 <sup>1</sup> / <sub>16</sub>	43 <sup>3</sup> / <sub>8</sub>	4	2	154

\*Unit weights are based on dry coils and minimum rows. Weights exclude packaging, valves, and other components.

42V Series Units

### 42VGA FURRED-IN WALL UNIT

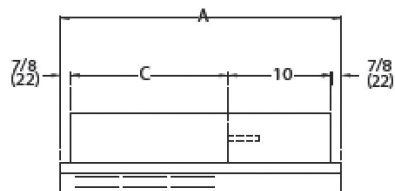

**TOP VIEW**  
(EXTENDED MODEL)  
STW

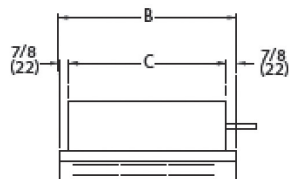

**TOP VIEW**  
(STANDARD MODEL)  
STY

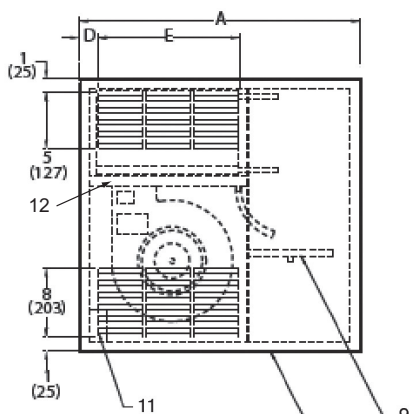

**FRONT VIEW**

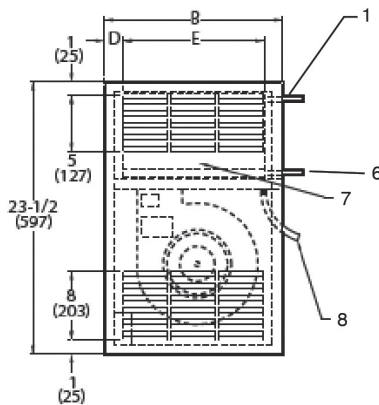

**FRONT VIEW**

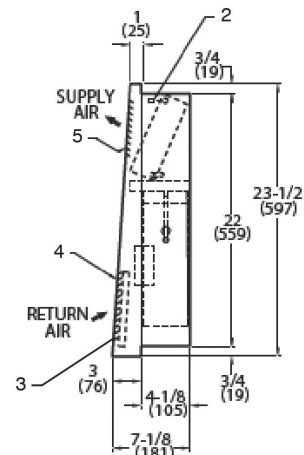

**RIGHT SIDE VIEW**

**LEGEND**

- 1 — Supply Conn, 5/8-in. OD
- 2 — Air Vent, 1/8-in. MPT
- 3 — Filter
- 4 — Return Air Grille, Stamped
- 5 — Stamped Supply Grille
- 6 — Return Conn, 5/8-in. OD
- 7 — Removable Front Panel
- 8 — Drain Conn, 7/8-in. OD
- 9 — Auxiliary Drain Pan
- 10 — Valve Compartment - (Optional)
- 11 — Junction Box
- 12 — Drain Pan

**NOTES:**

- 1. Right hand unit shown; left hand unit opposite. Coil connection locations are  $\pm 5/8$ -inches.
- 2. Front panel has an Arctic White baked finish.
- 3. Standard 2-row coil shown.
- 4. Unit size 01 has one motor, one blower; size 03 has 2 motors, 2 blowers.
- 5. Unit has 1/2-in. flanges for mounting to wall surface.
- 6. Front panel hooks at top of unit, swing down and snap in at bottom against a spring clip.
- 7. Not shown: 3-speed fan switch, wall plate, 1/2-in. fiberglass insulation on inside of casing, closed cell foam on main drain pan.
- 8. Dimensions shown in inches (mm).

UNIT SIZE	NOM AIRFLOW (Cfm)	DIMENSIONS (in.)					QTY/UNIT		UNIT WEIGHT* (lb)
		A	B	C	D	E	Blower	Motor	
01	150	25 <sup>3</sup> / <sub>4</sub>	15 <sup>3</sup> / <sub>4</sub>	14	1 <sup>1</sup> / <sub>2</sub>	12 <sup>3</sup> / <sub>4</sub>	1	1	40
03	300	39 <sup>3</sup> / <sub>4</sub>	29 <sup>3</sup> / <sub>4</sub>	28	1 <sup>15</sup> / <sub>16</sub>	25 <sup>7</sup> / <sub>8</sub>	2	2	74

\*Unit weights are based on dry coils and minimum rows. Weights exclude packaging, valves, and other components.

42V Series Units

# Accessory dimensions

## 42VAC,VBC,VFC OPTIONAL COIL CONNECTION LOCATION SIZES 02-12

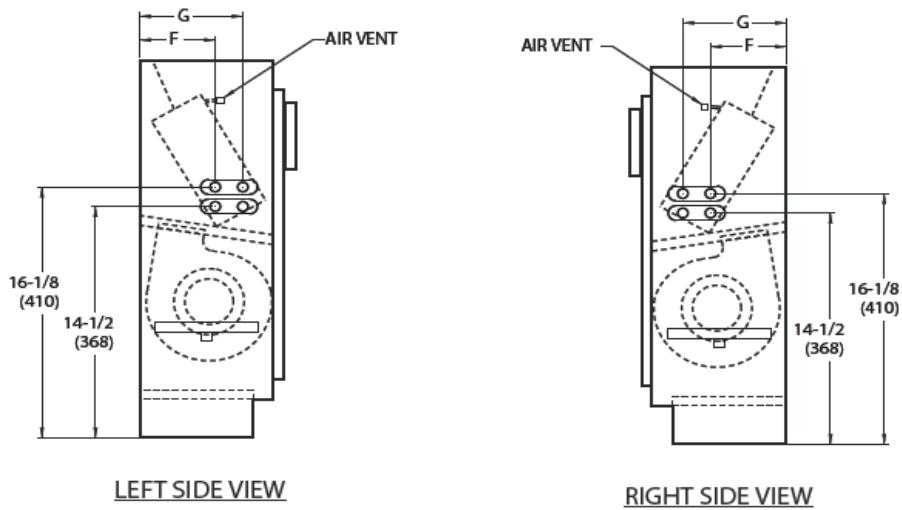

### COIL CONNECTION DIMENSIONS (in.)

UNIT SIZE	3-ROW COIL		4-ROW COIL		1-ROW HEAT WITH 3-ROW COOL		1-ROW HEAT WITH 4-ROW COOL		2-ROW HEAT WITH 3-ROW COOL		QUANTITY/UNIT	
	F SUPPLY	F RETURN	F SUPPLY	F RETURN	G SUPPLY	G RETURN	G SUPPLY	G RETURN	G SUPPLY	G RETURN	BLOWER	MOTOR
02	4 1/4	4 1/4	4 1/4	4 1/4	7 3/8	7 3/8	7 3/8	7 3/8	7 3/8	7 3/8	1	1
03	4 1/4	4 1/4	4 1/4	4 1/4	7 3/8	7 3/8	7 3/8	7 3/8	7 3/8	7 3/8	1	1
04	4 1/4	4 1/4	4 1/4	4 1/4	7 3/8	7 3/8	7 3/8	7 3/8	7 3/8	7 3/8	2	1
05	4 1/4	4 1/4	4 1/4	4 1/4	7 3/8	7 3/8	7 3/8	7 3/8	7 3/8	7 3/8	2	1
06	4 1/4	4 1/4	4 1/4	4 1/4	7 3/8	7 3/8	7 3/8	7 3/8	7 3/8	7 3/8	2	1
08	4 1/4	4 1/4	4 1/4	4 1/4	7 3/8	7 3/8	7 3/8	7 3/8	7 3/8	7 3/8	2	1
10	4 1/4	4 1/4	4 1/4	4 1/4	7 3/8	7 3/8	7 3/8	7 3/8	7 3/8	7 3/8	4	2
12	4 1/4	4 1/4	4 1/4	4 1/4	7 3/8	7 3/8	7 3/8	7 3/8	7 3/8	7 3/8	4	2

**NOTES:**

1. All dimensions are  $\pm 1/4$  inches.
2. Product specifications are subject to change without notice.
3. Same end dimensions are shown.

## DISCHARGE AIR GRILLES

DISCHARGE GRILLES					
Unit Size	Nominal Airflow (Cfm)	Recommended Grille Sizes (in.)			
		Unit			
		42VAC	42VBC,VFC	42VCA*	42VEA
02	200	16 x 5	16 x 6	16 x 5	16 x 6
03	300	18 x 5	16 x 6	22 x 5	22 x 6
04	400	26 x 5	26 x 6	30 x 5	30 x 6
05	500	26 x 5	26 x 6	—	—
06	600	36 x 5	36 x 6	44 x 5	44 x 6
08	800	38 x 5	38 x 6	—	—
10	1000	52 x 5	52 x 6	—	—
12	1200	60 x 5	60 x 6	—	—

\*Refer to unit dimensions to size field transitions.

### ANODIZED ALUMINUM DOUBLE-DEFLECTION GRILLE (With Frame)

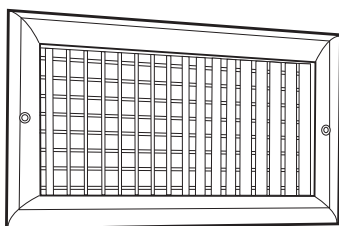

### INTEGRAL DOUBLE-DEFLECTION GRILLE FOR VERTICAL UNITS

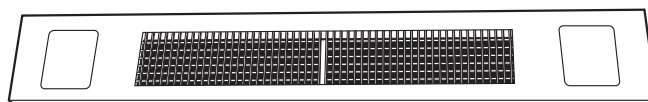

# Electrical data



## ELECTRIC HEATER DATA

HEATER VOLTAGE	HEATER kW						
	1.0	1.5	2.0	3.0	4.0	5.0	6.0
	FLA						
120	8.3	12.5	16.7	25.0	—	—	—
208	4.8	7.2	9.6	14.4	19.2	—	—
240	4.2	6.3	8.3	12.5	16.7	—	—
277	3.6	5.4	7.2	10.8	14.4	18.05	21.7

**LEGEND**

FLA — Full Load Amps

NOTE: All heaters are single-stage and single-phase.

## 42VAC, VBC, AND VFC PSC MOTOR DATA

42V Series Units

V-Ph-Hz	FAN SPEED	FAN SPEED (RPM)	UNIT SIZE								
			02			03			04		
			Nominal Hp	Watts	Amps	Nominal Hp	Watts	Amps	Nominal Hp	Watts	Amps
115-1-60	H	1200	1/40	60	0.39	1/30	80	0.69	1/12	125	1.20
	M	980		50	0.35		60	0.51		85	0.73
	L	790		45	0.28		50	0.42		60	0.56
208-1-60	H	1200	1/40	70	0.26	1/30	95	0.45	1/12	115	0.54
	M	980		65	0.24		70	0.35		85	0.41
	L	790		60	0.22		50	0.24		55	0.26
230-1-60	H	1200	1/40	75	0.28	1/30	110	0.47	1/12	130	0.56
	M	980		70	0.26		85	0.36		100	0.43
	L	790		65	0.24		60	0.25		60	0.28
277-1-60	H	1200	1/40	70	0.16	1/30	105	0.52	1/12	130	0.57
	M	980		60	0.13		85	0.37		105	0.41
	L	790		55	0.10		55	0.21		65	0.24

V-Ph-Hz	FAN SPEED	FAN SPEED	UNIT SIZE								
			05			06			08		
			Nominal Hp	Watts	Amps	Nominal Hp	Watts	Amps	Nominal Hp	Watts	Amps
115-1-60	H	1200	1/6	210	1.84	1/6	180	1.94	1/6	195	1.92
	M	980		125	1.22		140	1.30		150	1.35
	L	790		75	0.75		85	0.76		80	0.72
208-1-60	H	1200	1/6	180	0.90	1/6	145	0.74	1/6	155	0.79
	M	980		85	0.49		100	0.51		100	0.52
	L	790		65	0.037		60	0.31		55	0.30
230-1-60	H	1200	1/6	235	1.05	1/6	160	0.72	1/6	170	0.80
	M	980		95	0.49		115	0.51		115	0.54
	L	790		70	0.38		70	0.33		65	0.33
277-1-60	H	1200	1/6	100	0.63	1/6	185	0.68	1/6	195	0.74
	M	980		70	0.43		135	0.49		135	0.53
	L	790		70	0.38		110	0.41		110	0.43

V-Ph-Hz	FAN SPEED	FAN SPEED	UNIT SIZE					
			10*			12*		
			Nominal Hp	Watts	Amps	Nominal Hp	Watts	Amps
115-1-60	H	1200	1/12 (2)	260	2.54	1/6 (2)	335	3.75
	M	980		175	1.54		255	2.43
	L	790		135	1.18		160	1.47
208-1-60	H	1200	1/12 (2)	225	1.06	1/6 (2)	270	1.36
	M	980		175	0.81		190	0.97
	L	790		110	0.51		120	0.62
230-1-60	H	1200	1/12 (2)	260	1.10	1/6 (2)	295	1.37
	M	980		200	0.84		210	0.97
	L	790		130	0.54		140	0.66
277-1-60	H	1200	1/12 (2)	275	1.14	1/6 (2)	295	1.37
	M	980		215	0.80		250	0.91
	L	790		140	0.47		215	0.79

\*Total motor amps and watts shown for units with 2 motors.

**NOTES:**

- Motor nameplate amps may vary.
- Fan coil units comply with ETL, Canadian Standards Association (CSA), and ETL of Canada standards.



### 42VC,VEA PSC MOTOR DATA

V-Ph-Hz	FAN SPEED	FAN SPEED (RPM)	UNIT SIZE					
			02			03		
			Nominal Hp	Watts	Amps	Nominal Hp	Watts	Amps
115-1-60	H	1200	1/20	68	0.60	1/12	135	1.60
	M	980		45	0.30		65	0.60
	L	790		25	0.20		40	0.30
208-1-60	H	1200	1/20	56	0.50	1/12	109	0.66
	L	790		35	0.20		55	0.30
230-1-60	H	1200	1/20	64	0.50	1/12	128	0.66
	L	790		42	0.22		65	0.28
277-1-60	H	1200	1/20	85	0.30	1/12	135	0.50
	M	980		45	0.12		85	0.33
	L	790		35	0.07		55	0.22

V-Ph-Hz	FAN SPEED	FAN SPEED	UNIT SIZE					
			04			06*		
			Nominal Hp	Watts	Amps	Nominal Hp	Watts	Amps
115-1-60	H	1200	1/12	150	1.60	1/12 (2)	260	3.20
	M	980		65	0.60		125	1.20
	L	790		40	0.30		85	0.80
208-1-60	H	1200	1/12	116	0.66	1/12 (2)	232	1.32
	L	790		58	0.30		103	0.50
230-1-60	H	1200	1/12	138	0.66	1/12 (2)	245	1.32
	L	790		67	0.30		120	0.52
277-1-60	H	1200	1/12	140	0.50	1/12 (2)	260	1.00
	M	980		88	0.34		155	0.65
	L	790		57	0.22		100	0.40

\*Total motor amps and watts shown for units with 2 motors.

NOTES:

- Motor nameplate amps may vary.
- Fan coil units comply with ETL, Canadian Standards Association (CSA), and ETL of Canada standards.



42V Series Units

### 42VGA PSC MOTOR DATA

V-Ph-Hz	FAN SPEED	FAN SPEED (RPM)	UNIT SIZE					
			01			03*		
			Nominal Hp	Watts	Amps	Nominal Hp	Watts	Amps
115-1-60	H	1200	1/20	135	1.60	1/20 (2)	270	3.20
	M	980		83	1.00		167	1.91
	L	790		69	0.80		138	1.54

\*Total motor amps and watts shown for units with 2 motors.

NOTES:

- Motor nameplate amps may vary.
- Fan coil units comply with ETL, Canadian Standards Association (CSA), and ETL of Canada standards.



# Electrical data (cont)



## 42VAC, VBC, VCA, VEA, VFC ECM MOTOR DATA

SIZE	NOMINAL HP	AMPS				
		120V	208V	230V	277V	
42V**02	1/7	2.4	1.4	1.3	1.2	
42V**03	1/7					
42V**04	1/6					
42V**06	1/6			1.6	1.5	1.0
42V**08	1/6					
42V**10	1/6 (2)			3.2	3.0	2.0
42V**12	1/6 (2)					

42V Series Units



# Model number nomenclature

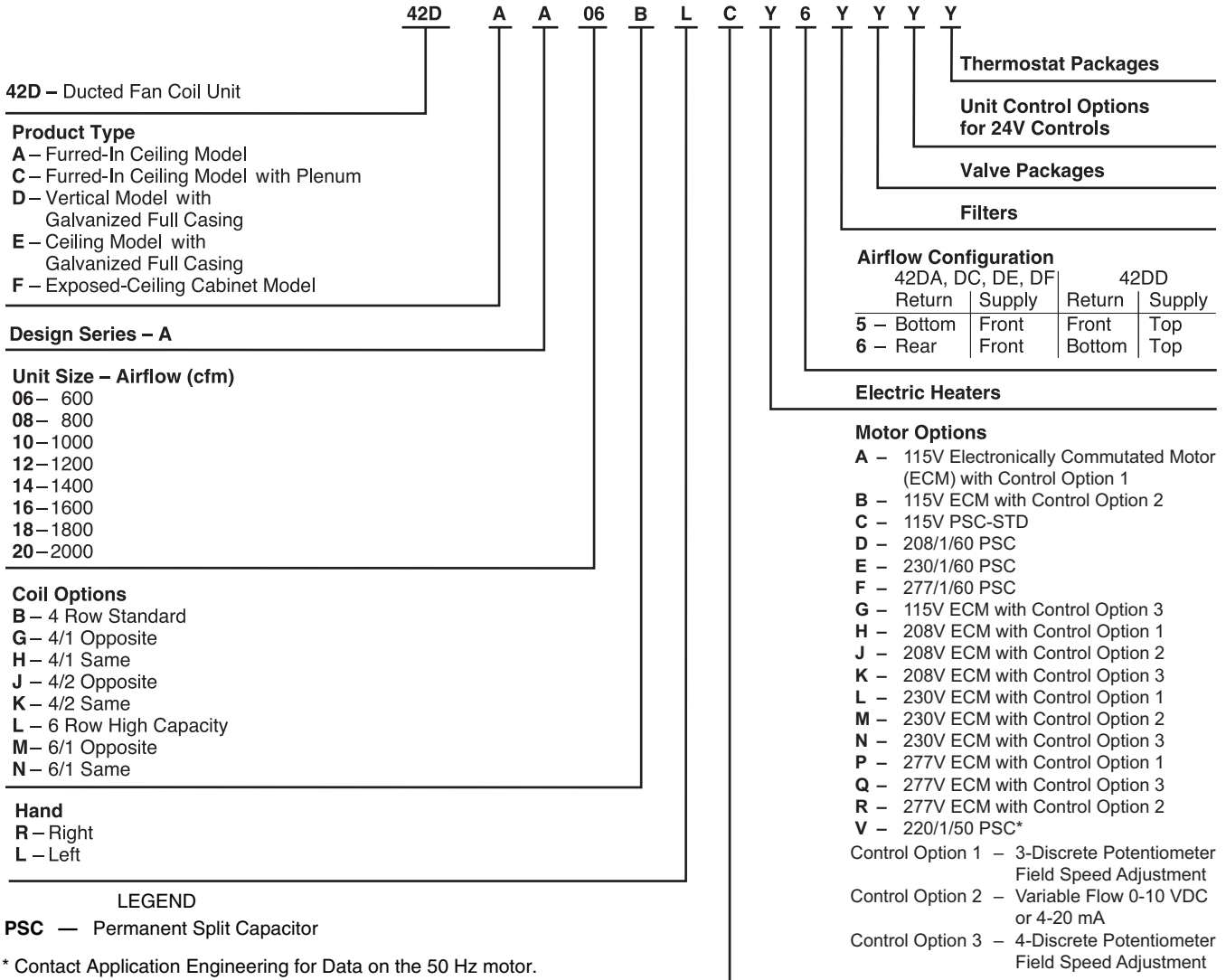

42D Series Units

## AHRI capacity ratings

The 42D Series fan coil units are certified in compliance with the Air-Conditioning, Heating and Refrigeration Institute (AHRI) Industry Standard 440 for room fan coil units. Approved standard ratings are tabulated below:



### AHRI APPROVED STANDARD RATINGS\*

UNIT TYPE	UNIT SIZE†	NOMINAL CFM	GPM	COOLING CAPACITY		POWER INPUT (WATTS)**
				Total Heat Btuh	Sensible Heat Btuh	
<b>42DF</b>	06	600	3.7	18,100	13,700	225
	08	800	5.0	23,400	17,600	275
	10	1000	6.9	33,300	24,000	400
	12	1200	8.7	41,800	30,200	450
	14	1400	10.0	48,900	34,000	470

\*Ratings based on motor at high fan speed, standard air and dry coil operation, 10°F water temperature rise; entering-air temperatures of 80 F db, 67 F wb; entering-water temperature 45 F.

\*\*Motor type, permanent split capacitor, operating at 115-1-60 voltage.

†With standard 4-row coil.

# Physical data



UNIT SIZE 42D	06	08	10	12	14	16	18	20
<b>NOMINAL AIRFLOW (cfm)</b>	600	800	1000	1200	1400	1600	1800	2000
<b>SHIPPING WEIGHT (lb)*</b>								
42DA	64	79	90	108	119	124	141	151
42DC	94	107	150	169	174	178	195	220
42DD	135	145	155	180	190	200	215	230
42DE	150	160	170	195	205	215	230	235
42DF	157	167	177	202	215	225	240	255
<b>COIL WATER WEIGHT (Approx lb per row of coil)</b>	1.3	1.6	1.9	2.3	2.7	3.0	3.4	3.7
<b>COILS</b>								
FPI	10 fins/inch							
Coil Face Area (sq ft)	1.6	2.1	2.5	3.0	3.5	4.1	4.6	5.0
<b>MOTOR (qty)</b>	1	1	1	2	2	2	2	2
<b>BLOWER (qty)</b>	1	1	1	2	2	2	2	2
<b>FILTERS</b>								
Nominal Size (in.) (1-in. thick)								
42DA	NA							
42DC	14 x 21	14 x 26	14 x 30	14 x 35	14 x 40	14 x 45	14 x 50	14 x 54
42DD								
(Front Return)	12 <sup>3</sup> / <sub>4</sub> x 21	12 <sup>3</sup> / <sub>4</sub> x 26	12 <sup>3</sup> / <sub>4</sub> x 30	12 <sup>3</sup> / <sub>4</sub> x 35	12 <sup>3</sup> / <sub>4</sub> x 40	12 <sup>3</sup> / <sub>4</sub> x 45	12 <sup>3</sup> / <sub>4</sub> x 50	12 <sup>3</sup> / <sub>4</sub> x 54
(Bottom Return)	12 <sup>3</sup> / <sub>4</sub> x 20	12 <sup>3</sup> / <sub>4</sub> x 25	12 <sup>3</sup> / <sub>4</sub> x 29	12 <sup>3</sup> / <sub>4</sub> x 34	12 <sup>3</sup> / <sub>4</sub> x 39	12 <sup>3</sup> / <sub>4</sub> x 44	12 <sup>3</sup> / <sub>4</sub> x 49	12 <sup>3</sup> / <sub>4</sub> x 53
42DE	14 x 14 <sup>3</sup> / <sub>4</sub>	14 x 19 <sup>3</sup> / <sub>4</sub>	14 x 23 <sup>3</sup> / <sub>4</sub>	14 x 28 <sup>3</sup> / <sub>4</sub>	14 x 33 <sup>3</sup> / <sub>4</sub>	14 x 38 <sup>3</sup> / <sub>4</sub>	14 x 43 <sup>3</sup> / <sub>4</sub>	14 x 47 <sup>3</sup> / <sub>4</sub>
42DF	14 x 14	14 x 20	14 x 24	14 x 28	14 x 34	14 x 38	14 x 44	14 x 48
Qty	1							
<b>SUPPLY DUCT COLLAR</b>	1-in.							
<b>PIPING CONNECTIONS</b>								
Coil Inlet/Outlet (in. OD)								
1 and 2 Row	5/8	5/8	5/8	5/8	5/8	5/8	5/8	5/8
3 Row	5/8	5/8	7/8	7/8	7/8	7/8	7/8	7/8
4 Row	7/8	7/8	7/8	7/8	7/8	1 1/8	1 1/8	1 1/8
5 Row	7/8	7/8	7/8	7/8	1 1/8	1 1/8	1 1/8	1 1/8
6 Row	7/8	7/8	7/8	7/8	1 1/8	1 1/8	1 1/8	1 1/8
8 Row	1 1/8	1 1/8	1 1/8	1 1/8	1 5/8	1 5/8	1 5/8	1 5/8

\*Calculate Operating Weight of unit: Shipping Weight + Coil Water Weight x Number of Coil Rows.

# Base unit dimensions

## 42DA FURRED-IN CEILING UNIT WITH ELECTRIC HEAT

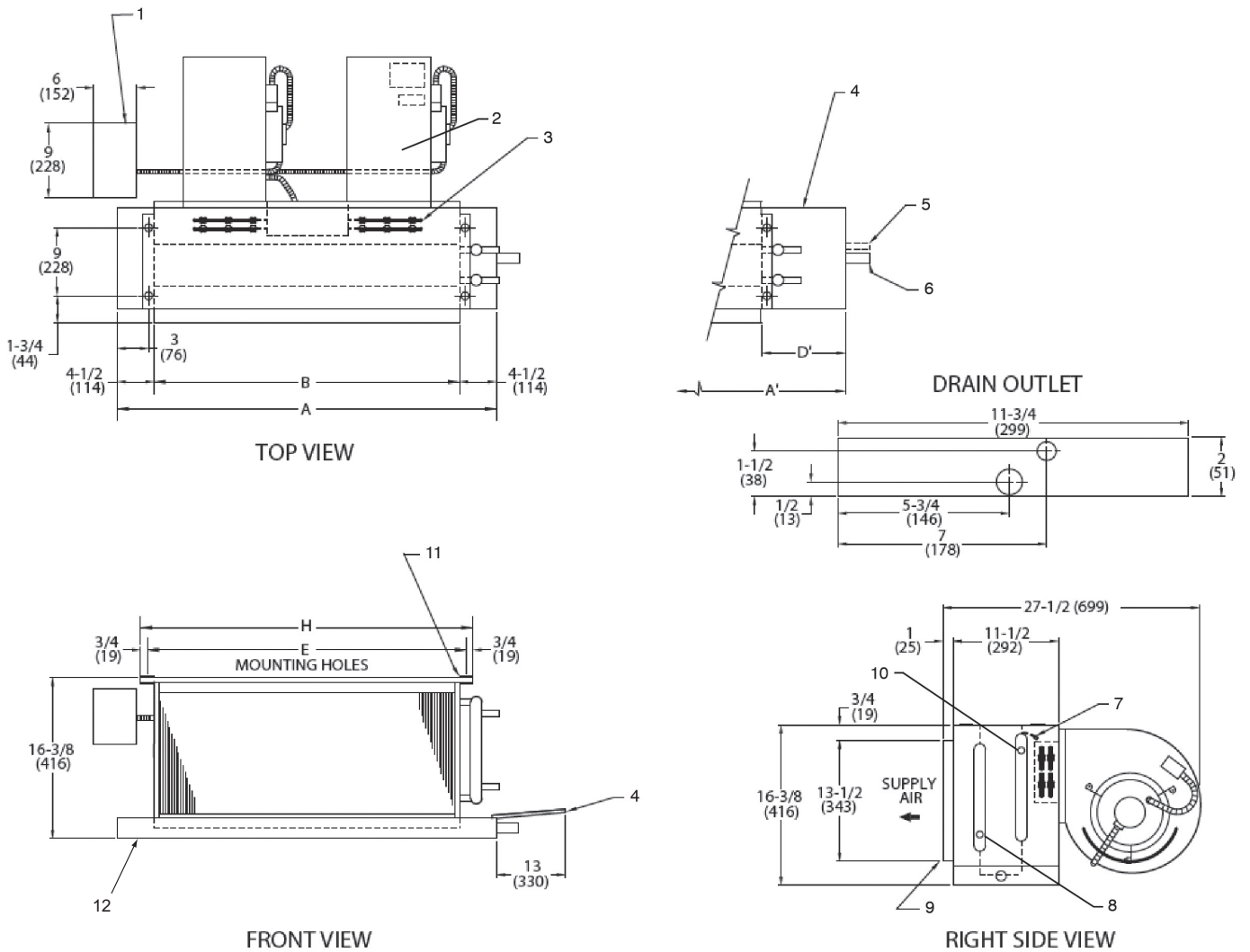

UNIT SIZE	NOM AIRFLOW (Cfm)	DIMENSIONS (in. ± 1/8)						QTY/UNIT		UNIT WEIGHT* (lb)
		A	A'	B	D'	E	H	Blower	Motor	
06	600	23	32	14	13 1/2	17	18 3/4	1	1	64
08	800	28	37	19	13 1/2	22	23 3/4	1	1	79
10	1000	32	42	23	14 1/2	26	27 3/4	1	1	90
12	1200	37	47	28	14 1/2	31	32 3/4	2	2	108
14	1400	42	52	33	14 1/2	36	37 3/4	2	2	119
16	1600	47	56	38	13 1/2	41	42 3/4	2	2	124
18	1800	52	62	43	14 1/2	46	47 3/4	2	2	141
20	2000	56	66	47	14 1/2	50	51 3/4	2	2	151

- LEGEND
- 1 — Motor Junction Box
  - 2 — Motor-Blower Assembly
  - 3 — Electric Strip Heater Element (optional)
  - 4 — Auxiliary Drip Lip (Optional, Shipped Loose)
  - 5 — Tell-Tale Drain (optional)
  - 6 — Drain Connection, 7/8-in. OD
  - 7 — Air Vent, 1/8-in. MPT
  - 8 — Supply Connection
  - 9 — Supply Duct Collar, 1 inch
  - 10 — Return Connection
  - 11 — Mounting Holes (four, 3/4-in. diameter) have Rubber Grommets with 3/8-in. holes.
  - 12 — Drain Pan

\*Unit weights are based on dry coils and minimum rows. Weights exclude packaging, valves, and other components.

NOTES:

1. Right hand unit shown; left hand unit opposite. Coil connection locations are ± 5/8 inches.
2. Sizes 06, 08 and 10 have one motor, one blower; sizes 12 through 20 have 2 motors, 2 blowers.
3. Standard 4-row coil shown. Other coil option dimensional data available on request.
4. See 42DA-203-1 for optional coil connections.
5. Fan switch, wall plate not shown.
6. Galvanized finish provided as standard.
7. Dimensions are in inches (mm).

42D Series Units

# Base unit dimensions (cont)

## 42DC FURRED-IN CEILING UNIT WITH PLENUM AND ELECTRIC HEAT

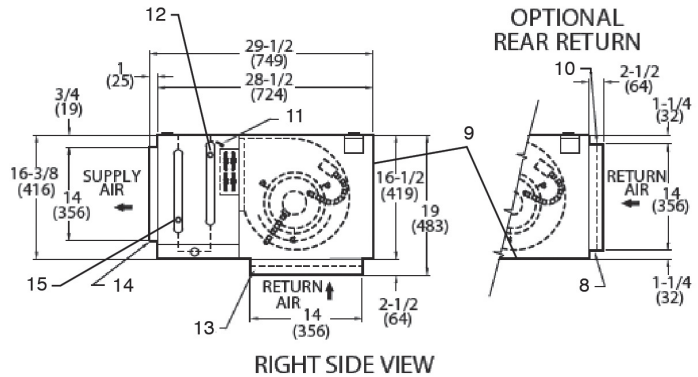
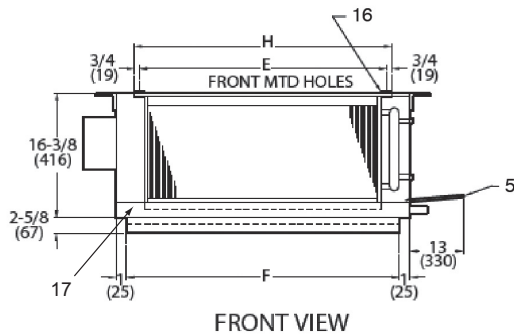
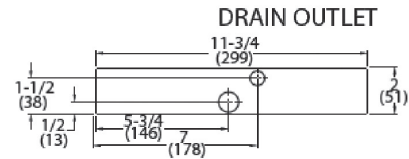
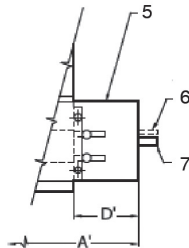
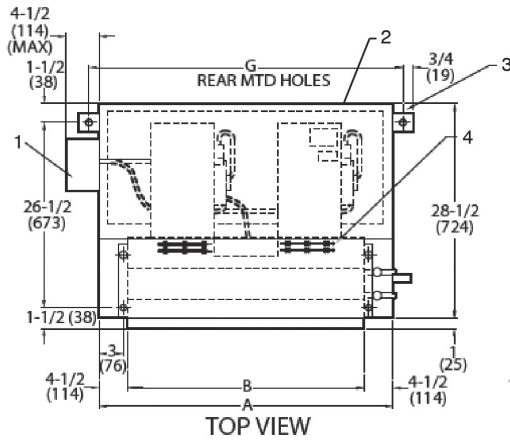

UNIT SIZE	NOM AIRFLOW (Cfm)	DIMENSIONS (in. ± 1/8)								QTY/UNIT		UNIT WEIGHT* (lb)
		A	A'	B	D'	E	F	G	H	Blower	Motor	
06	600	23	32	14	13 1/2	17	21	25 1/4	18 3/4	1	1	94
08	800	28	37	19	13 1/2	22	26	30 1/4	23 3/4	1	1	107
10	1000	32	42	23	14 1/2	26	30	34 1/4	27 3/4	1	1	150
12	1200	37	47	28	14 1/2	31	35	39 1/4	32 3/4	2	2	169
14	1400	42	52	33	14 1/2	36	40	44 1/4	37 3/4	2	2	174
16	1600	47	56	38	13 1/2	41	45	49 1/4	42 3/4	2	2	178
18	1800	52	62	43	14 1/2	46	50	54 1/4	47 3/4	2	2	195
20	2000	56	66	47	14 1/2	50	54	58 1/4	51 3/4	2	2	220

\*Unit weights are based on dry coils and minimum rows. Weights exclude packaging, valves, and other components.

**NOTES:**

1. Right hand unit shown; left hand unit opposite. Coil connection locations are ± 5/8 inches.
2. Sizes 06, 08 and 10 have one motor, one blower. Sizes 12 through 20 have 2 motors, 2 blowers.
3. Filter and filter rack are standard.
4. Standard 4-row coil shown. Other coil option dimensional data available on request.
5. See 42DA-203-1 for optional coil connections.
6. Fan switch, wall plate not shown.
7. Galvanized finish provided as standard.
8. Dimensions are in inches (mm).

**LEGEND**

- 1 — Motor Junction Box Opposite Piping
- 2 — Insulated Return Air Plenum
- 3 — Mounting Clips (Shipped Loose)
- 4 — Electrical Strip Heater Element (optional)
- 5 — Auxiliary Drip Lip (Shipped Loose) with 3/8-in. Hole
- 6 — Tell-Tale Drain (optional)
- 7 — Drain Connection, 7/8-in. OD
- 8 — Filter Retainer Angle
- 9 — Access Panel
- 10 — Return Duct Collar, 2 1/2 inches
- 11 — Air Vent, 1/8-in. MPT
- 12 — Return Connection
- 13 — Filter, 1-in.
- 14 — Supply Duct Collar, 1 inch
- 15 — Supply Connection
- 16 — Mounting Holes (four, 3/4-in. diameter) with Rubber Grommet
- 17 — Drain Pan

42D Series Units

### 42DD VERTICAL UNIT WITH FULL CASING AND ELECTRIC HEAT

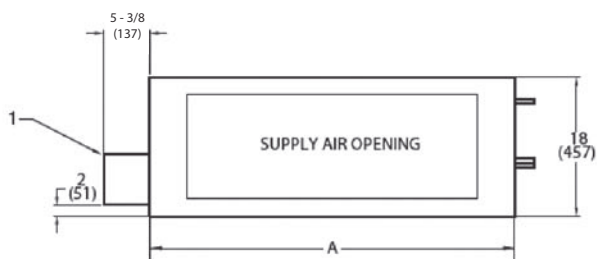

TOP VIEW

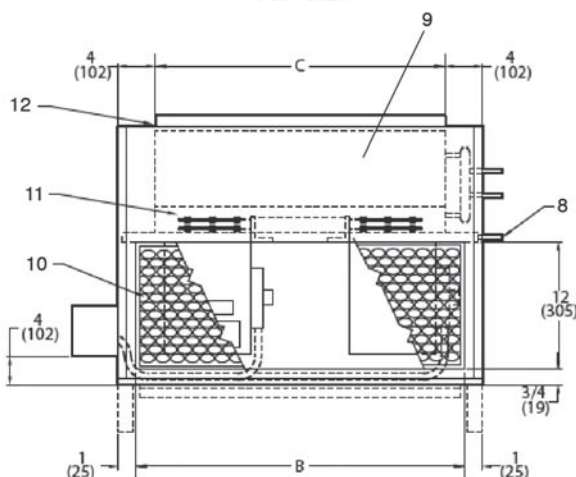

FRONT VIEW

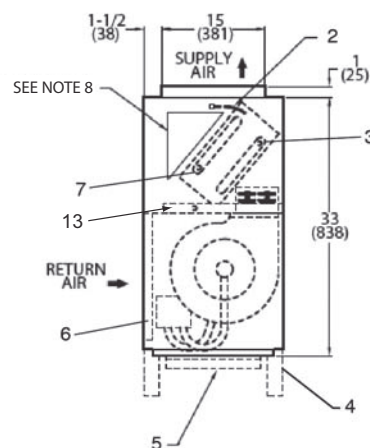

RIGHT SIDE VIEW

UNIT SIZE	NOM AIRFLOW (Cfm)	DIMENSIONS (in. ± 1/8)			QTY/UNIT		UNIT WEIGHT* (lb)
		A	B	C	Blower	Motor	
06	600	23	21	15	1	1	135
08	800	28	26	20	1	1	145
10	1000	32	30	24	1	1	155
12	1200	37	35	29	2	2	180
14	1400	42	40	34	2	2	190
16	1600	47	45	39	2	2	200
18	1800	52	50	44	2	2	215
20	2000	56	54	48	2	2	230

LEGEND

- 1 — Motor Junction Box
- 2 — Air Vent, 1/8-in. MPT
- 3 — Return Connection
- 4 — Optional 6-in. Legs
- 5 — Bottom Return (optional)
- 6 — Return Air Opening
- 7 — Supply Connection
- 8 — Drain Connection, 7/8-in. OD
- 9 — Front Access Panel
- 10 — Filter, Throwaway
- 11 — Electric Strip Heater Element (optional)
- 12 — Supply Duct Connection, 1-in.
- 13 — Drain Pan

\*Unit weights are based on dry coils and minimum rows. Weights exclude packaging, valves, and other components.

NOTES:

1. Right hand unit shown; left hand unit opposite. Coil connection locations are ± 5/8 inches.
2. Standard 4-row coil shown. Other coil option dimensional data available on request.
3. Sizes 06, 08 and 10 have one motor, one blower. Sizes 12 through 20 have 2 motors, 2 blowers.
4. Supply and return connections terminate within unit when valves are factory installed.
5. See 42DD-203-1 for optional coil connections.
6. Fan switch and wall plate are not shown.
7. Galvanized finish provided as standard.
8. Units with internal factory valve packages have external connections located in triangular section above coil.
9. Consult Carrier for ducted front return air and external filter rack with 1-in. duct collar and throwaway filters.
10. Units with electric heat require additional access on the side of unit for servicing contactor box.
11. With bottom return, access to filter is through the front access panel.
12. Dimensions are in inches (mm).

42D Series Units

# Base unit dimensions (cont)

## 42DE CEILING UNIT WITH FULL CASING AND ELECTRIC HEAT

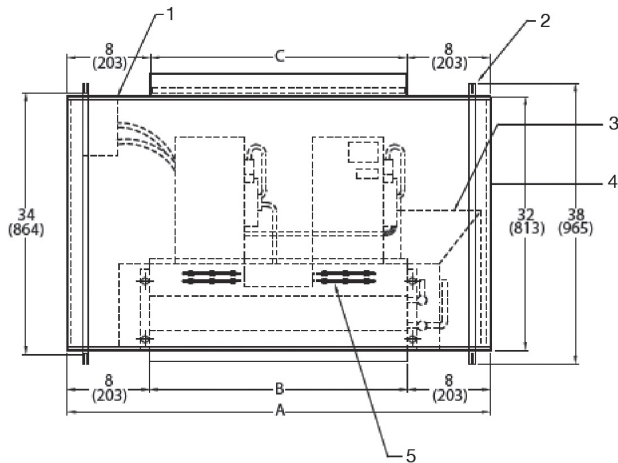

TOP VIEW

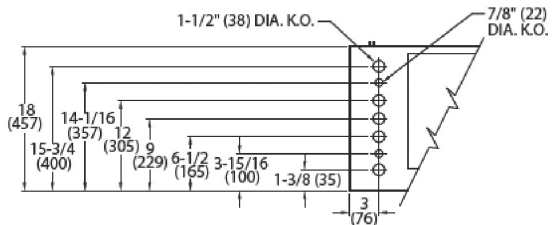

PARTIAL REAR VIEW (TYP. BOTH SIDES)

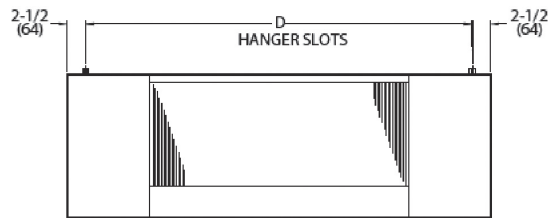

FRONT VIEW

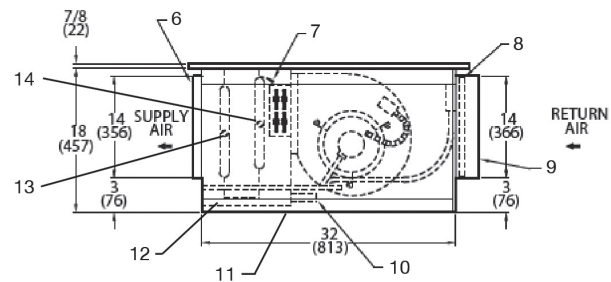

RIGHT SIDE VIEW

42D Series Units

UNIT SIZE	NOM AIRFLOW (Cfm)	DIMENSIONS (in. ± 1/8)				QTY/UNIT		UNIT WEIGHT* (lb)
		A	B	C	D	Blower	Motor	
06	600	31	15	15	26	1	1	150
08	800	36	20	20	31	1	1	160
10	1000	40	24	24	35	1	1	170
12	1200	45	29	29	40	2	2	195
14	1400	50	34	34	45	2	2	205
16	1600	55	39	39	50	2	2	215
18	1800	60	44	44	55	2	2	230
20	2000	64	48	48	59	2	2	235

\*Unit weights are based on dry coils and minimum rows. Weights exclude packaging, valves, and other components.

**NOTES:**

1. Right hand unit shown; left hand unit opposite.
2. Coil stub-out location data available on request.
3. Unit fabricated of galvanized steel.
4. Internal parts fabricated of galvanized steel.
5. Sizes 06, 08 and 10 have one motor, one blower. Sizes 12 through 20 have 2 motors, 2 blowers.
6. Units must have drain line pitched and trapped externally.
7. See 42DA-203-1 for optional coil connections.
8. Fan switch, wall plate not shown.
9. Galvanized finished provided as standard.
10. Dimensions are in inches (mm).

**LEGEND**

- 1 — Motor Junction Box
- 2 — Unit Mounting Channel (2), 14-gage; 4 Mounting Slots, 1/2-in. x 2-in.
- 3 — Auxiliary Drip Lip (optional, shipped loose)
- 4 — Side Access Panels
- 5 — Electrical Strip Heater Element (optional)
- 6 — Supply Air Duct Connection, 1 in.
- 7 — Manual Air Vent
- 8 — Filter, Throwaway, 1-in.
- 9 — Return Air Duct Connection, 2 1/2 in.
- 10 — Drain, 7/8-in. OD
- 11 — Bottom Access Panel
- 12 — Drain Pan
- 13 — Coil Inlet, Copper Sweat Connection
- 14 — Coil Outlet, Copper Sweat Connection

### 42DF EXPOSED CEILING UNIT WITH DISCHARGE AND RETURN GRILLE AND ELECTRIC HEAT

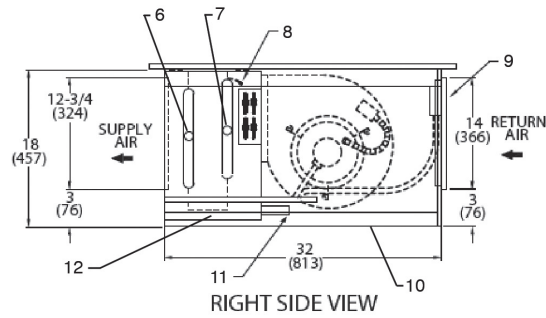
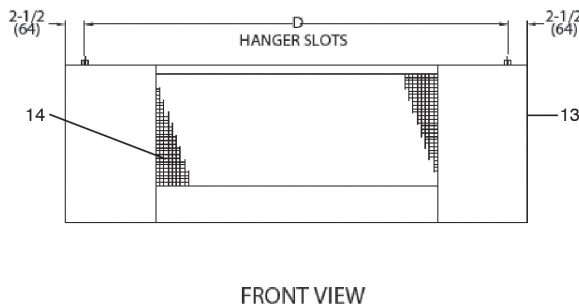
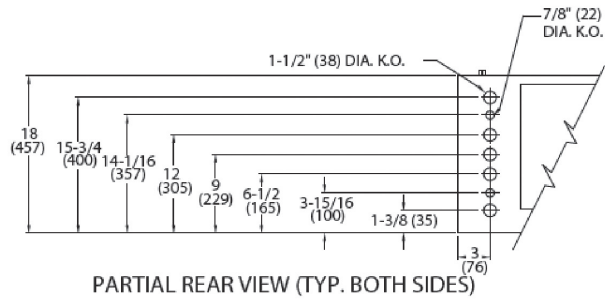
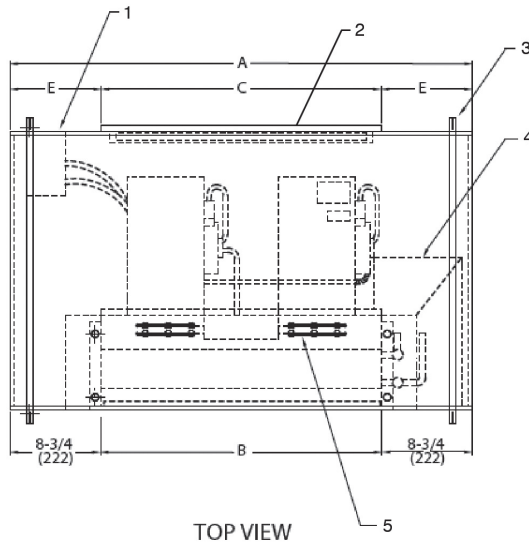

UNIT SIZE	NOM AIRFLOW (Cfm)	DIMENSIONS (in. ± 1/8)					QTY/UNIT		UNIT WEIGHT* (lb)
		A	B	C	D	E	Blower	Motor	
06	600	31	13	14	26	8 1/2	1	1	157
08	800	36	18	20	31	8	1	1	167
10	1000	40	22	24	35	8	1	1	177
12	1200	45	27	28	40	8 1/2	2	2	202
14	1400	50	32	34	45	8	2	2	215
16	1600	55	37	38	50	8 1/2	2	2	225
18	1800	60	42	44	55	8	2	2	240
20	2000	64	46	48	59	8	2	2	255

#### LEGEND

- 1 — Junction Box
- 2 — Return Air Grille, Hinged, Bar Type, with Filter Frame (Anodized Aluminum Only)
- 3 — Unit Mounting Channel (2), 14-gage; 4 Mounting Slots, 1/2 in. x 2-in.
- 4 — Auxiliary Drip Lip
- 5 — Electric Strip Heater Element (optional)
- 6 — Coil Inlet, Copper Sweat Connection
- 7 — Coil Outlet, Copper Sweat Connection
- 8 — Manual Air Vent
- 9 — Filter, Throwaway
- 10 — Bottom Access Panel
- 11 — Drain, 7/8-in. OD
- 12 — Drain Pan Insulated with Styrofoam
- 13 — Side Access Panel (2)
- 14 — Discharge Air Grille (Double Deflection)

\*Unit weights are based on dry coils and minimum rows. Weights exclude packaging, valves, and other components.

#### NOTES:

1. Right hand unit shown; left hand unit opposite.
2. Coil stub-out connection data available on request.
3. Units fabricated of galvanized steel with an Arctic White baked finish.
4. Internal parts fabricated of galvanized steel.
5. Sizes 06, 08 and 10 have one motor, one blower. Sizes 12 through 20 have 2 motors, 2 blowers.
6. Units must have drain line pitched and trapped externally.
7. Stamped supply and return grilles are not available.
8. Bottom return air is not available.
9. See 42DA-203-1 for optional coil connections.
10. Fan switch and wall plate are not shown.
11. Dimensions are in inches (mm).

42D Series Units

# Electrical data



## 42D ELECTRIC HEATER DATA

HEATER VOLTAGE	HEATER kW										
	2.0	3.0	4.0	5.0	6.0	7.0	8.0	9.0	10.0	12.0	14.0
	FLA										
120	16.7	25.0	—	—	—	—	—	—	—	—	—
208	9.6	14.4	19.2	24.0	28.8	33.7	38.5	43.3	48.1	57.7	67.3
240	8.3	12.5	16.7	20.8	25.0	29.2	33.3	37.5	41.7	50.0	58.3
277	7.2	10.8	14.4	18.0	21.7	25.3	28.9	32.5	36.1	43.3	50.5

### LEGEND

FLA — Full Load Amps

### NOTES:

- All heaters are single-stage and single-phase.
- In all units using over 48 amps, the heating elements are sub-divided and protected. Additional cost is incurred because of added components.

- A separate power source is required for motor and heaters except when motors and heaters of same voltage are ordered in conjunction with a single power source wiring option. This option, which meets NEC (National Electric Code) requirements, consists of a factory-furnished and installed junction box and fuse for 6.25 amp (max) fan and control circuit connection to a single power source. Power supply circuit to unit must be field furnished and installed in accordance with applicable codes.

## 42DA PSC MOTOR DATA

V-Ph-Hz	FAN SPEED	FAN SPEED (RPM)	UNIT SIZE											
			06			08			10			12*		
			Nominal Hp	Watts	Amps	Nominal Hp	Watts	Amps	Nominal Hp	Watts	Amps	Nominal Hp	Watts	Amps
115-1-60	H	1200		280	2.70		330	3.10		470	5.60		550	5.30
	M	980	1/8	200	2.00	1/5	225	2.25	1/4	360	3.70	1/10 (2)	305	2.92
	L	790		140	1.50		135	1.44		240	2.60		205	1.93
208/230-1-60	H	1200		240	1.10		420	1.80		430	2.00		450	2.10
	M	980	1/10	175	0.74	1/5	280	1.26	1/4	260	1.20	1/10 (2)	325	1.45
	L	790		110	0.50		155	0.73		165	0.80		215	1.00
277-1-60	H	1200		275	1.15		275	1.21		425	1.62		550	2.40
	M	980	1/5	175	0.69	1/5	175	0.69	1/4	260	1.04	1/5 (2)	355	1.38
	L	790		90	0.33		90	0.34		155	0.65		175	0.67

V-Ph-Hz	FAN SPEED	FAN SPEED (RPM)	UNIT SIZE											
			14*			16*			18*			20*		
			Nominal Hp	Watts	Amps	Nominal Hp	Watts	Amps	Nominal Hp	Watts	Amps	Nominal Hp	Watts	Amps
115-1-60	H	1200		650	6.40		900	8.80		1180	11.80		1180	11.80
	M	980	1/5 (2)	440	4.60	1/5 (2)	705	6.90	1/4 (2)	770	8.30	1/4 (2)	770	8.30
	L	790		280	3.00		430	4.20		460	5.30		460	5.30
208/230-1-60	H	1200		465	2.10		740	3.60		925	4.10		925	4.10
	M	980	1/10 (2)	325	1.45	1/5 (2)	360	1.80	1/4 (2)	5.45	2.48	1/4 (2)	545	2.48
	L	790		220	1.00		220	1.20		330	1.60		330	1.60
277-1-60	H	1200		735	2.70		940	3.60		980	3.72		980	3.72
	M	980	1/4 (2)	510	1.90	1/4 (2)	560	2.20	1/4 (2)	550	2.20	1/4 (2)	550	2.20
	L	790		330	1.30		335	1.40		320	1.40		320	1.40

\*Total motor amps and watts shown for units with 2 motors (size 12 through 20).

### NOTES:

- Motor nameplate amps may vary.
- Fan coil units comply with ETL, Canadian Standards Association (CSA), and ETL of Canada standards.





### 42DC, DD AND DE PSC MOTOR DATA

V-Ph-Hz	FAN SPEED	FAN SPEED (RPM)	UNIT SIZE											
			06			08			10			12*		
			Nominal Hp	Watts	Amps	Nominal Hp	Watts	Amps	Nominal Hp	Watts	Amps	Nominal Hp	Watts	Amps
115-1-60	H	1200		265	2.60		310	3.00		440	4.50		550	5.40
	M	980	1/8	195	1.95	1/5	220	2.30	1/4	330	3.40	1/8 (2)	390	3.90
	L	790		155	1.54		140	1.50		225	2.50		305	3.10
208/230-1-60	H	1200		235	1.00		325	1.45		410	1.80		700	3.20
	M	980	1/10	165	0.72	1/5	210	0.95	1/4	250	1.10	1/5 (2)	430	2.00
	L	790		110	0.49		135	0.62		160	0.76		305	1.48
277-1-60	H	1200		275	1.10		275	1.40		395	1.51		535	2.40
	M	980	1/5	175	0.70	1/5	175	0.69	1/4	260	1.10	1/5 (2)	360	1.40
	L	790		90	0.33		90	0.34		155	0.65		190	0.70

V-Ph-Hz	FAN SPEED	FAN SPEED (RPM)	UNIT SIZE											
			14*			16*			18*			20*		
			Nominal Hp	Watts	Amps	Nominal Hp	Watts	Amps	Nominal Hp	Watts	Amps	Nominal Hp	Watts	Amps
115-1-60	H	1200		690	6.80		900	9.80		1015	10.20		1020	10.20
	M	980	1/5 (2)	560	5.40	1/4 (2)	725	7.70	1/4 (2)	745	7.80	1/4 (2)	750	7.80
	L	790		280	3.50		450	5.24		450	5.30		460	5.30
208/230-1-60	H	1200		720	3.30		680	3.00		820	3.70		820	3.70
	M	980	1/5 (2)	440	2.00	1/5 (2)	445	2.00	1/4 (2)	500	2.20	1/4 (2)	510	2.20
	L	790		310	1.48		285	1.33		330	1.50		330	1.50
277-1-60	H	1200		700	2.65		830	3.20		900	3.50		925	3.52
	M	980	1/4 (2)	495	1.96	1/4 (2)	510	2.00	1/4 (2)	550	2.23	1/4 (2)	550	2.23
	L	790		300	1.30		300	1.30		320	1.36		320	1.36

\*Total motor amps and watts shown for units with 2 motors (size 12-20).

NOTES:

- Motor nameplate amps may vary.
- Fan coil units comply with ETL, Canadian Standards Association (CSA), and ETL of Canada standards.



### 42DF PSC MOTOR DATA

V-Ph-Hz	FAN SPEED	FAN SPEED (RPM)	UNIT SIZE											
			06			08			10			12*		
			Nominal Hp	Watts	Amps	Nominal Hp	Watts	Amps	Nominal Hp	Watts	Amps	Nominal Hp	Watts	Amps
115-1-60	H	1200		260	2.40		275	3.10		380	3.70		490	4.40
	M	980	1/10	195	1.70	1/8	205	2.10	1/5	300	3.00	1/10 (2)	310	3.00
	L	790		125	1.15		155	1.58		210	2.00		210	2.10
208/230-1-60	H	1200		235	1.00		230	1.05		410	1.80		450	2.00
	M	980	1/10	165	0.72	1/8	145	0.65	1/4	220	1.05	1/10 (2)	300	1.40
	L	790		105	0.48		105	0.48		160	0.75		224	1.05
277-1-60	H	1200		205	0.72		270	0.90		285	1.27		370	1.44
	M	980	1/10	140	0.51	1/10	190	0.71	1/5	180	0.73	1/10 (2)	235	0.89
	L	790		90	0.31		155	0.57		95	0.37		165	0.63

V-Ph-Hz	FAN SPEED	FAN SPEED (RPM)	UNIT SIZE											
			14*			16*			18*			20*		
			Nominal Hp	Watts	Amps	Nominal Hp	Watts	Amps	Nominal Hp	Watts	Amps	Nominal Hp	Watts	Amps
115-1-60	H	1200		520	5.00		670	6.50		800	7.40		840	8.20
	M	980	1/10 (2)	320	3.00	1/5 (2)	470	4.80	1/5 (2)	670	6.60	1/5 (2)	685	6.60
	L	790		210	2.10		300	3.10		420	4.10		435	4.20
208/230-1-60	H	1200		470	2.10		590	2.90		705	3.20		810	3.44
	M	980	1/10 (2)	340	1.50	1/8 (2)	440	2.10	1/5 (2)	420	2.00	1/4 (2)	495	2.20
	L	790		230	1.10		300	1.45		315	1.55		320	1.50
277-1-60	H	1200		450	1.60		470	1.70		620	2.80		870	3.30
	M	980	1/10 (2)	330	1.28	1/10 (2)	350	1.20	1/5 (2)	420	1.65	1/4 (2)	545	2.20
	L	790		250	0.90		250	0.90		230	0.95		320	1.36

\*Total motor amps and watts shown for units with 2 motors (size 12-20).

NOTES:

- Motor nameplate amps may vary.
- Fan coil units comply with ETL, Canadian Standards Association (CSA), and ETL of Canada standards.



42D Series Units

# Electrical data (cont)



## 42D ECM MOTOR DATA

SIZE	NOMINAL HP	AMPS			
		120V	208V	230V	277V
42D*06	1/2	8.4	4	4	3.3
42D*08	1/2				
42D*10	1/2				
42D*12	1/2 (2)	16.8	8	8	6.6
42D*14	1/2 (2)				
42D*16	1/2 (2)				
42D*18	1/2 (2)				
42D*20	1/2 (2)				

# Model number nomenclature



42S GA 06 B F Y A A F Y YY

42S – Vertical Stack Unit

**Product Type**

- GA – Furred-In Single
- GM – Furred-In Master
- GS – Furred-In Slave
- HA – Cabinet/Exposed
- JA – Furred-In Back-to-Back Master
- JB – Furred-In Back-to-Back Slave
- MA – Furred-In Mega
- UB – Furred-In Universal

**Unit Size – Airflow (cfm)**

- |           |           |
|-----------|-----------|
| 03 – 300  | 12 – 1200 |
| 04 – 400  | 14 – 1400 |
| 06 – 600  | 16 – 1600 |
| 08 – 800  | 20 – 2000 |
| 10 – 1000 |           |

**Coil**

- A – 3 Row (Std)
- B – 4 Row
- C – 5 Row
- D – 3/1 Same End
- F – 3/2 Same End
- H – 4/1 Same End

**Motors**

- A – 277V ECM with Control Option 1
- C – 115/1/60 PSC 3-Speed
- D – 208/1/60 PSC 3-Speed
- E – 230/1/60 PSC 3-Speed
- F – 277/1/60 PSC 3-Speed
- G – 115/1/60 High Static PSC 3-Speed
- H – 208/1/60 High Static PSC 3-Speed
- I – 230/1/60 High Static PSC 3-Speed
- J – 277/1/60 High Static PSC 3-Speed
- K – 115V ECM with Control Option 1
- L – 208V ECM with Control Option 1
- M – 230V ECM with Control Option 1
- O – 115V ECM with Control Option 3
- P – 208V ECM with Control Option 3
- Q – 230V ECM with Control Option 3
- R – 277V ECM with Rheostat Field Speed Adjustment
- S – 115V ECM with Control Option 2
- T – 208V ECM with Control Option 2
- U – 230V ECM with Control Option 2
- W – 277V ECM with Control Option 3
- Z – 277V ECM with Control Option 2
- 4 – 115V ECM with Rheostat Field Speed Adjustment
- 5 – 208V ECM with Rheostat Field Speed Adjustment
- 6 – 230V ECM with Rheostat Field Speed Adjustment
- Control Option 1 – 3-Discrete Potentiometer  
Field Speed Adjustment
- Control Option 2 – Variable Flow 0-10 VDC  
or 4-20 mA
- Control Option 3 – 4-Discrete Potentiometer  
Field Speed Adjustment

**Thermostat Package\***

YY – No Controls

**Riser Piping, Cabinet Height and Upsizing†**

- A – Std Riser Piping, 1-Cabinet Upsize, Std Cabinet Height
- B – Std Riser Piping, 2-Cabinet Upsize, Std Cabinet Height
- C – Std Riser Piping, Std Cabinet Size, Short Cabinet Height
- D – Std Riser Piping, 1-Cabinet Upsize, Short Cabinet Height
- E – Std Riser Piping, 2-Cabinet Upsize, Short Cabinet Height
- R – Reverse Riser Piping, Std Cabinet Size, Std Cabinet Height
- S – Reverse Riser Piping, 1-Cabinet Upsize, Std Cabinet Height
- T – Reverse Riser Piping, 2-Cabinet Upsize, Std Cabinet Height
- U – Reverse Riser Piping, Std Cabinet Size, Short Cabinet Height
- V – Reverse Riser Piping, 1-Cabinet Upsize, Short Cabinet Height
- W – Reverse Riser Piping, 2-Cabinet Upsize, Short Cabinet Height
- Y – Std Riser Piping, Std Cabinet Size, Std Cabinet Height

**Cabinet Insulation**

- F – ½ in. Foil Face
- P – ½ in. Closed Cell (Unit)
- Y – ½ in. Fiberglass (Std)

**Filters**

- A – 1 in. Throwaway (Std)
- B – 1 in. Permanent
- C – 1 in. Pleated (MERV 8)
- D – 1 in. Pleated (MERV 13)

**Arrangement\***

**Heaters\***

Y – None

**LEGEND**

- ECM – Electronically Commutated Motor
- PSC – Permanent Split Capacitor

\*Contact your local Carrier representative for further options.  
†An upsized cabinet is one size bigger than the standard cabinet.

# AHRI capacity ratings



The 42S Series fan coil units are certified in compliance with the Air-Conditioning, Heating and Refrigeration Institute (AHRI) Industry Standard 440 for room fan coil units. Approved standard ratings are tabulated below:



## AHRI APPROVED STANDARD RATINGS — STANDARD CAPACITY COIL

UNIT TYPE*	UNIT SIZE	COIL	NOMINAL CFM	GPM	COOLING CAPACITY		POWER INPUT (Watts)†
					Total Heat Btuh	Sensible Heat Btuh	
42S	03	3-Row	300	2.7	11,500	7,000	85
		4-Row	300	3.2	12,200	7,300	85
	04	3-Row	400	2.8	13,600	9,000	115
		4-Row	400	3.5	15,600	9,600	115
	06	3-Row	600	4.1	21,900	14,000	135
		4-Row	600	5.1	26,000	15,300	135
	08	3-Row	800	4.4	27,500	17,800	250
		4-Row	800	5.6	31,400	19,500	250
	10	3-Row	1000	6.3	37,700	24,500	325
		4-Row	1000	7.5	42,200	25,600	325
	12	3-Row	1200	6.7	43,100	28,400	440
		4-Row	1200	8.0	46,500	30,500	440
	14**	3-Row	1400	7.7	38,300	27,900	670
		4-Row	1400	9.0	45,200	32,400	630

\*Table values are listed for each half of 42SJ units and master/slave.  
 †Motor type, permanent split capacitor, operating at 115-1-60 voltage.  
 \*\*Size 14 only available with 42SM unit.

### NOTES:

- Ratings based on motor at high fan speed, standard air and dry coil operation, 10° F water temperature rise; entering-air temperatures of 80 F db, 67 F wb; entering-water temperature 45 F.
- Nominal airflow for Mega Stack unit sizes 16 and 20 fall outside the performance range covered by standard AHRI 440 for room fan coils.

## Physical data

UNIT SIZE 42S	03	04	06	08	10	12	14	16	20
NOMINAL AIRFLOW (cfm)	300	400	600	800	1000	1200	1400	1600	2000
SHIPPING WEIGHT (lb)*									
42SGA,SGM,SU	180	225	240	260	280	305	—	—	—
42SH	202	247	262	286	311	336	—	—	—
42SJ	360	450	480	520	560	610	—	—	—
42SGS	162	203	216	234	252	275	—	—	—
42SM	—	—	—	—	—	—	390	390	390
COIL WATER WEIGHT (Approx lb per row of coil)	1.79		2.63		3.45		4.09	4.09	4.39
COILS FPI	14 fins/inch								
BLOWER (qty)									
42SGA,SH,SU,SGM,SGS,SM	1	1	1	1	1	1	1	1	1
42SJ	2	2	2	2	2	2	—	—	—
FILTERS									
Nominal Size (in.) (1-in. thick)	12 <sup>1</sup> / <sub>2</sub> x 24 <sup>1</sup> / <sub>4</sub>		16 <sup>1</sup> / <sub>4</sub> x 26 <sup>3</sup> / <sub>4</sub>		20 <sup>1</sup> / <sub>2</sub> x 29 <sup>1</sup> / <sub>4</sub>		24 <sup>1</sup> / <sub>2</sub> x 29 <sup>1</sup> / <sub>2</sub>		26 <sup>1</sup> / <sub>2</sub> x 29 <sup>1</sup> / <sub>2</sub>
Qty	1†								
PIPING CONNECTIONS Inlet (in. OD)	1/2, unless larger size valve package is selected								

\*Calculate Operating Weight of Unit: Shipping Weight + Coil Water Weight x Number of Coil Rows.

†42SJ units require two filters.

# Base unit dimensions

## 42SGA FURRED-IN STACK UNIT WITHOUT RISER CHASE

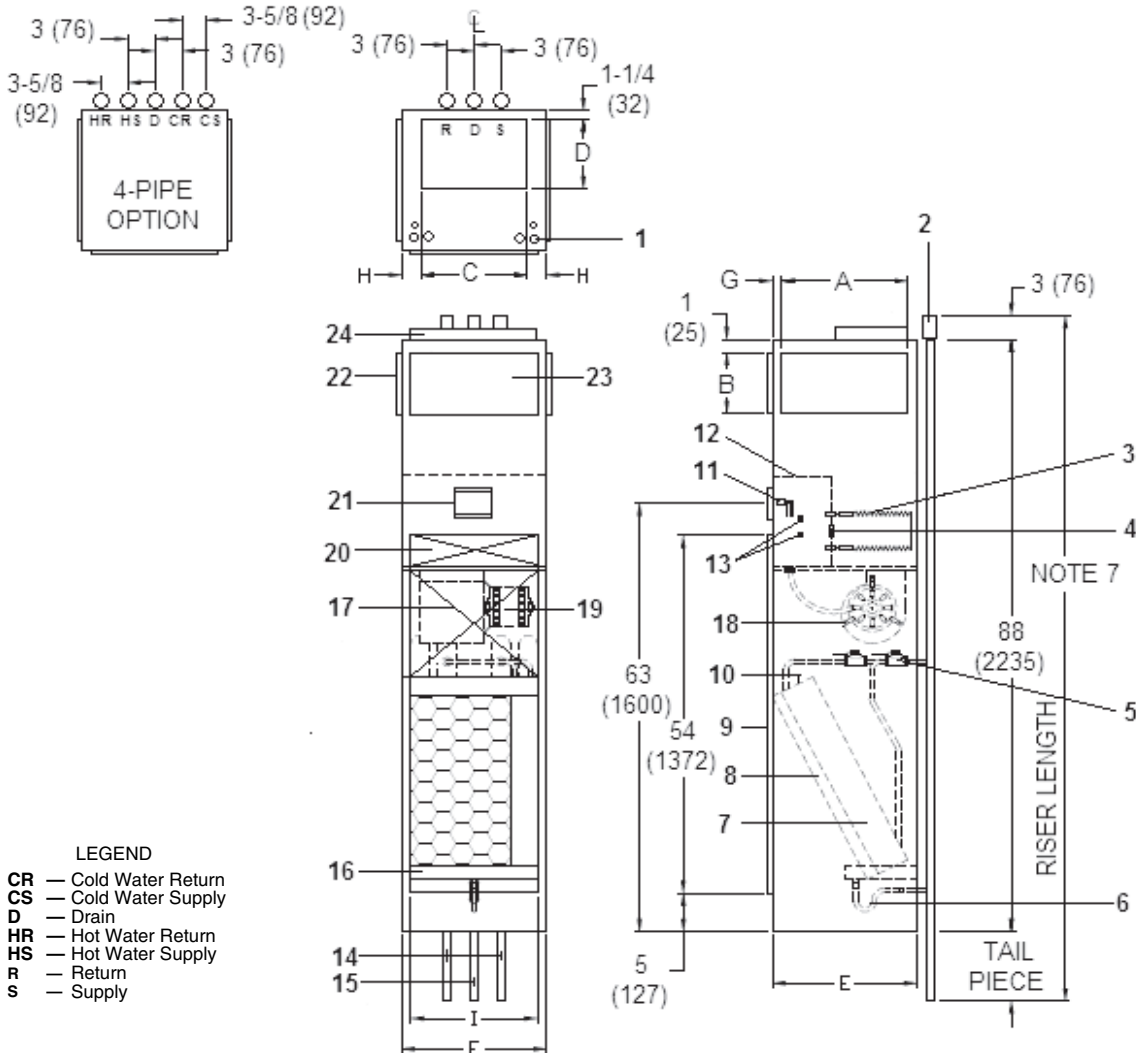

**LEGEND**  
**CR** — Cold Water Return  
**CS** — Cold Water Supply  
**D** — Drain  
**HR** — Hot Water Return  
**HS** — Hot Water Supply  
**R** — Return  
**S** — Supply

ITEM	DESCRIPTION	QTY
1	Electrical Knockouts	1
2	3-in. Expanded Section of Riser	3/5
3	Strip Heater (Optional)	1
4	Limit Switch (Optional)	1
5	1/2-in. Isolation Ball Valve	2/4
6	Flexible Drain Tube/P-Trap	1
7	Coil 1/2-in. OD Copper Tube	1
8	Filter, Throwaway, 1-in.	1
9	Return Air Opening	1
10	Air Vent, Manual	1
11	Molex Connector for Field-Installed Tstat	1
12	Control Box	1
13	Knockout (For Optional Remote Mounting)/ Side	2
14	Riser, Supply and Return (Copper)	2/4
15	Riser, Drain (Copper)	1
16	Drain Pan	1
17	Acoustical Bypass Panel	1
18	Blower	1
19	Motor, 3-Speed, PSC, with Quick Connect	1
20	Access Panel (Control Box)	1
21	Control Opening (Surface Mount Tstat)	1
22	Duct Collar, 1/2-in. Extension	1/2/3
23	Supply Air Opening(s)	1/2/3
24	Top Supply Duct Collar 1-in. Extension (Optional)	1

**NOTES:**

- Units are fabricated of galvanized steel with a 16-gage galvanized fan deck.
- All risers are insulated with (1/2-in. or 3/4-in. thick) closed cell insulation.
- Thermostat shipped loose for field installation when ordered with the unit.
- Risers are factory piped to coil with valve package as specified.
- Blower, motor, coil, valves, and filter are accessible through the return air opening.
- Unit and control box are insulated.
- Riser length = [(floor to floor) + 2 in.], maximum riser length = 119 inches.
- Maximum riser size is 2 1/2-in. diameter. If larger size is required, please consult the factory.
- Expansion loops in hot water heating circuits as required.
- Dimensions are in inches. Dimensions in ( ) are in millimeters.
- Drawing is pictorial (see unit arrangements for actual supply and return air orientation).
- A 9-in. x 2 1/4-in. slot is provided in the inside back panel for coil connection penetration to permit expansion and contraction of riser. Care must be taken to position the riser so that coil connection is at center of slot.

UNIT MODEL	SINGLE SUPPLY			DOUBLE SUPPLY			TOP SUPPLY			DIMENSIONS - INCHES				FILTER SIZE
	A	B	SIZE	A	B	SIZE	C	D	SIZE	E	G	H	I	
42SGA03	14	8	14 X 8	14	6	14 X 6	14	10	14 x 10	17	1 1/2	1 1/2	14	12 1/2 X 24 1/4 X 1
42SGA04	14	12	14 X 12	14	6	14 X 6	14	10	14 x 10	17	1 1/2	1 1/2	14	12 1/2 X 24 1/4 X 1
42SGA06	18	10	18 X 10	18	6	18 X 6	16	12	16 x 12	20	1	2	18	16 1/4 X 26 3/4 X 1
42SGA08	18	12	18 X 12	18	6	18 X 6	16	12	16 x 12	20	1	2	18	16 1/4 X 26 3/4 X 1
42SGA10	—	—	—	22	8	22 X 8	18	16	18 x 16	24	1	3	22	20 1/2 X 29 1/4 X 1
42SGA12	—	—	—	22	8	22 X 8	18	16	18 x 16	24	1	3	22	20 1/2 X 29 1/4 X 1

# Base unit dimensions (cont)

## 42SHA CABINET STACK UNIT

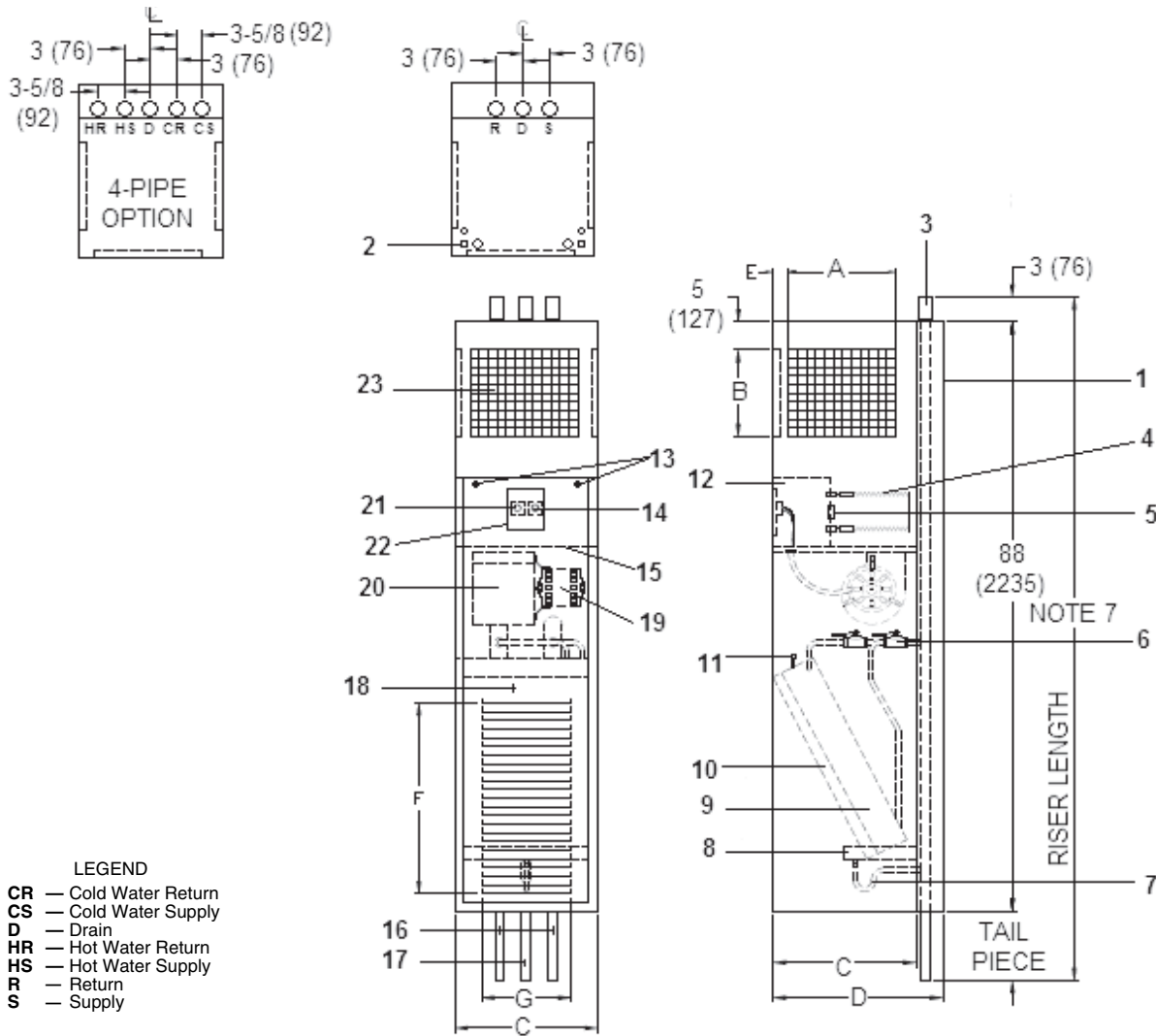

- LEGEND**
- CR — Cold Water Return
  - CS — Cold Water Supply
  - D — Drain
  - HR — Hot Water Return
  - HS — Hot Water Supply
  - R — Return
  - S — Supply

\*Drawing provided for reference only. Dimensions may vary with options ordered.

**NOTES:**

1. Units are fabricated of galvanized steel with a 16-gage galvanized fan deck.
2. All risers are insulated with (1/2-in. or 3/4-in. thick) closed cell insulation.
3. Risers are piped to coil with valve package as specified.
4. Blower, motor, coil, valves, and filter are accessible through the return air opening.
5. Unit and control box are insulated.
6. Maximum riser size is 2 1/2-in. diameter. If larger sizes are required, please consult the factory.
7. Riser length = [(floor to floor) +2 in.], maximum riser length = 119 inches.
8. Expansion loops in hot water heating circuits as required.
9. Drawing is pictorial (see unit arrangements for actual supply and return air orientation).
10. Unit is available in front return only.
11. Dimensions are in inches. Dimensions are in millimeters.
12. A 9-in. x 2 1/4-in. slot is provided in the inside back panel for coil connection penetration to permit expansion and contraction of risers. Care must be taken to position the risers so that coil connection is at center of slot.

ITEM	DESCRIPTION	QTY
1	Full Riser Chase	1
2	Electrical Knockouts	1
3	3-in. Expansion Section of Riser	3/5
4	Strip Heater (Optional)	1
5	Limit Switch (Optional)	1
6	1/2-in. Isolation Ball Valve	2/4
7	Flexible Drain Tube/P-Trap	1
8	Drain Pan	1
9	Coil 1/2-in. OD Copper Tube	1
10	Filter, Throwaway, 1-in.	1
11	Air Vent, Manual	1
12	Control Box	1
13	Cabinet Camloc Fastener	2
14	3-Speed Switch (Optional)	1
15	Electrical Access Panel	1
16	Riser, Supply and Return (Copper)	2/4
17	Riser, Drain (Copper)	1
18	Return Air Panel	1
19	Motor, 3-Speed, PSC with Quick Connect	1
20	Blower	1
21	Thermostat (Optional)	1
22	Hinged Control Access Door	1
23	Double Deflection Steel Core Grille Assembly	1

UNIT MODEL	SINGLE SUPPLY			DOUBLE SUPPLY			DIMENSIONS - INCHES					FILTER SIZE
	A	B	SIZE	A	B	SIZE	C	D	E	F	G	
42SHA03	14	8	14 X 8	14	6	14 X 6	17	22 3/8	2 1/2	22 1/8	14 3/4	12 1/2 X 24 1/4 X 1
42SHA04	14	12	14 X 12	14	8	14 X 8	17	22 3/8	2 1/2	22 1/8	14 3/4	12 1/2 X 24 1/4 X 1
42SHA06	14	12	14 X 12	14	8	14 X 8	20	25 3/8	2 1/2	26 5/8	17 3/4	16 1/4 X 26 3/4 X 1
42SHA08	14	16	14 X 16	14	10	14 X 10	20	25 3/8	2 1/2	26 5/8	17 3/4	16 1/4 X 26 3/4 X 1
42SHA10	18	16	18 X 16	14	12	14 X 12	24	29 3/8	2 1/2	31 1/8	17 3/4	20 1/2 X 29 1/4 X 1
42SHA12	18	16	18 X 16	14	12	14 X 12	24	29 3/8	2 1/2	31 1/8	17 3/4	20 1/2 X 29 1/4 X 1

### 42SJA/42SJB FURRED-IN STACK BACK TO BACK UNIT

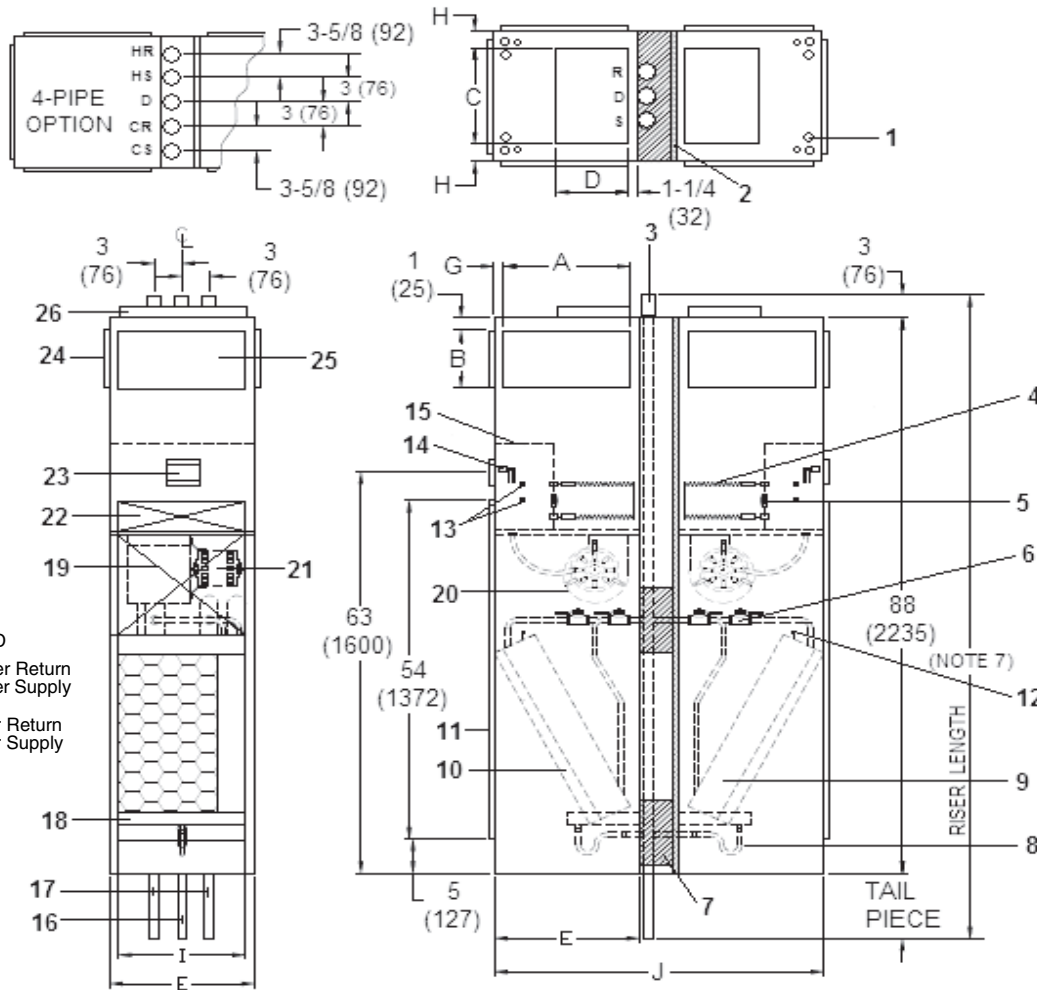

**LEGEND**

- CR — Cold Water Return
- CS — Cold Water Supply
- D — Drain
- HR — Hot Water Return
- HS — Hot Water Supply
- R — Return
- S — Supply

ITEM	DESCRIPTION	QTY
1	Electrical Knockouts	6
2	Gypsum Board 5/8" Type X	1
3	3-in. Expanded Section of Riser	3/5
4	Strip Heater (Optional)	2
5	Limit Switch (Optional)	2
6	1/2-in. Isolation Ball Valve	2/4
7	Thermafiber Insulation	—
8	Flexible Drain Tube/P-Trap	2
9	Coil 1/2-in. OD Copper Tube	2
10	Filter, Throwaway, 1-in.	2
11	Return Air Opening	2
12	Air Vent, Manual	2
13	Knockout (For Optional Remote Mounting/ Side)	2
14	Molex Connector for Field-Installed Tstat	2
15	Control Box	2
16	Riser, Drain (Copper)	1
17	Riser, Supply and Return (Copper)	2/4
18	Drain Pan	2
19	Acoustical Bypass Panel	2
20	Blower	2
21	Motor, 3-Speed, PSC, with Quick Connect	2
22	Access Panel (Control Box)	2
23	Control Opening (Surface Mount Tstat)	2
24	Duct Collar, 1/2-in. Extension (Typical)	1/2/3
25	Supply Air Opening(s)	1/2/3
26	Top Supply Duct Collar, 1-in. Extension (Optional)	1

**NOTES:**

1. Units are fabricated of galvanized steel with a 16-gage galvanized fan deck.
2. All risers are insulated with (1/2-in. or 3/4-in. thick) closed cell insulation.
3. Thermostat shipped loose for field installation when ordered with the unit.
4. Risers are piped to coil with valve package as specified.
5. Blower, motor, coil, valves, and filter are accessible through the return air opening.
6. Unit and control box are insulated.
7. Riser length = [(floor to floor) + 2 in.], maximum riser length = 119 inches.
8. Maximum riser size is 2 1/2-in. diameter. If larger size is required, please consult the factory.
9. Expansion loops in hot water heating circuits as required.
10. Drawing is pictorial (see unit arrangements for actual supply and return air orientation).
11. Dimensions are in inches. Dimensions in ( ) are in millimeters.
12. A 9-in. x 2 1/4-in. slot is provided in the inside back panel for coil connection penetration to permit expansion and contraction of riser. Care must be taken to position the riser so that coil connection is at center of slot.

UNIT MODEL	SINGLE SUPPLY			DOUBLE SUPPLY			TOP SUPPLY			DIMENSIONS - INCHES					FILTER SIZE
	A	B	SIZE	A	B	SIZE	C	D	SIZE	E	G	H	I	J	
42SJA03	14	8	14 X 8	14	6	14 X 6	14	10	14 x 10	17	1 1/2	1 1/2	14	39 5/8	12 1/2 X 24 1/4 X 1
42SJA04	14	12	14 X 12	14	6	14 X 6	14	10	14 x 10	17	1 1/2	1 1/2	14	39 5/8	12 1/2 X 24 1/4 X 1
42SJA06	18	10	18 X 10	18	6	18 X 6	16	12	16 x 12	20	1	2	18	45 5/8	16 1/4 X 26 3/4 X 1
42SJA08	18	12	18 X 12	18	6	18 X 6	16	12	16 x 12	20	1	2	18	45 5/8	16 1/4 X 26 3/4 X 1
42SJA10	—	—	—	22	8	22 X 8	18	16	18 x 16	24	1	3	22	53 5/8	20 1/2 X 29 1/4 X 1
42SJA12	—	—	—	22	8	22 X 8	18	16	18 x 16	24	1	3	22	53 5/8	20 1/2 X 29 1/4 X 1

42S Series Units

# Base unit dimensions (cont)

## 42SGM FURRED-IN STACK MASTER UNIT

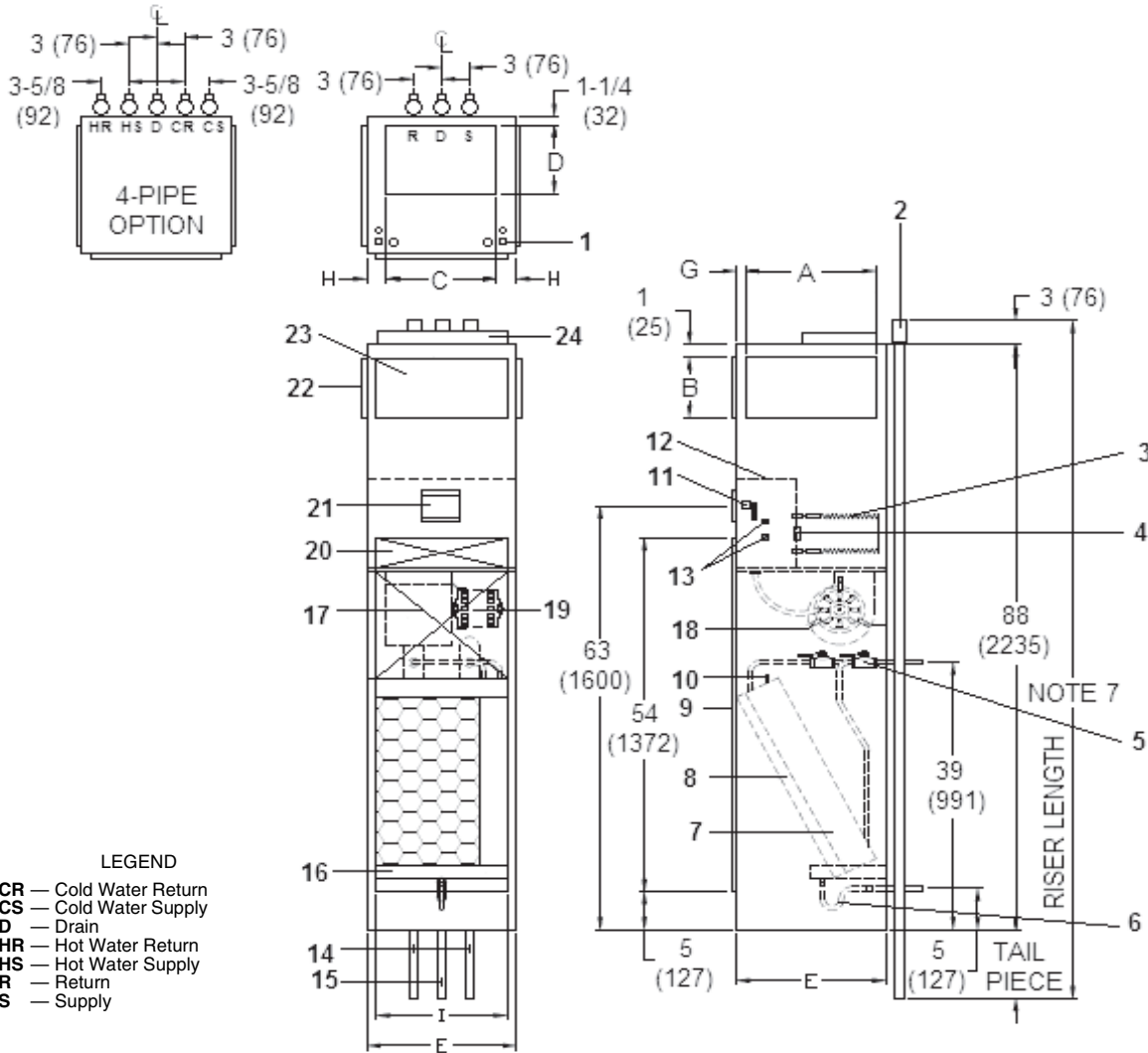

- LEGEND**
- CR — Cold Water Return
  - CS — Cold Water Supply
  - D — Drain
  - HR — Hot Water Return
  - HS — Hot Water Supply
  - R — Return
  - S — Supply

ITEM	DESCRIPTION	QTY
1	Electrical Knockouts	1
2	3-in. Expanded Section of Riser	3/5
3	Strip Heater (Optional)	1
4	Limit Switch (Optional)	1
5	1/2-in. Isolation Ball Valve	2/4
6	Flexible Drain Tube/P-Trap	1
7	Coil 1/2-in. OD Copper Tube	1
8	Filter, Throwaway, 1-in.	1
9	Return Air Opening	1
10	Air Vent, Manual	1
11	Molex Connector for Field-Installed Tstat	1
12	Control Box	1
13	Knockout (For Optional Remote Mounting)/ Side	2
14	Riser, Supply and Return (Copper)	2/4
15	Riser, Drain (Copper)	1
16	Drain Pan	1
17	Acoustical Bypass Panel	1
18	Blower	1
19	Motor, 3-Speed, PSC, with Quick Connect	1
20	Access Panel (Control Box)	1
21	Control Opening (Surface Mount Tstat)	1
22	Duct Collar, 1/2-in. Extension (Typical)	1/2/3
23	Supply Air Opening(s)	1/2/3
24	Top Supply Duct Collar, 1-in. Extension (Optional)	1

**NOTES:**

1. Units are fabricated of galvanized steel with a 16-gage galvanized fan deck.
2. All risers are insulated with (1/2-in. or 3/4-in. thick) closed cell insulation.
3. Thermostat shipped loose for field installation when ordered with the unit.
4. Risers are piped to coil with valve package as specified.
5. Blower, motor, coil, valves, and filter are accessible through the return air opening.
6. Unit and control box are insulated.
7. Riser length = [(floor to floor) + 2 in.], maximum riser length = 119 inches.
8. Maximum riser size is 2 1/2-in. diameter. If larger size is required, please consult the factory.
9. Expansion loops in hot water heating circuits as required.
10. Drawing is pictorial (see unit arrangements for actual supply and return air orientation).
11. Dimensions are in inches. Dimensions in ( ) are in millimeters.
12. A 9-in. x 2 1/4-in. slot is provided in the inside back panel for coil connection penetration to permit expansion and contraction of riser. Care must be taken to position the riser so that coil connection is at center of slot.

UNIT MODEL	SINGLE SUPPLY			DOUBLE SUPPLY			TOP SUPPLY			DIMENSIONS - INCHES				FILTER SIZE
	A	B	SIZE	A	B	SIZE	C	D	SIZE	E	G	H	I	
42SGM03	14	8	14 X 8	14	6	14 X 6	14	10	14 x 10	17	1 1/2	1 1/2	14	12 1/2 X 24 1/4 X 1
42SGM04	14	12	14 X 12	14	6	14 X 6	14	10	14 x 10	17	1 1/2	1 1/2	14	12 1/2 X 24 1/4 X 1
42SGM06	18	10	18 X 10	18	6	18 X 6	16	12	16 x 12	20	1	2	18	16 1/4 X 26 3/4 X 1
42SGM08	18	12	18 X 12	18	6	18 X 6	16	12	16 x 12	20	1	2	18	16 1/4 X 26 3/4 X 1
42SGM10	—	—	—	22	8	22 X 8	18	16	18 x 16	24	1	3	22	20 1/2 X 29 1/4 X 1
42SGM12	—	—	—	22	8	22 X 8	18	16	18 x 16	24	1	3	22	20 1/2 X 29 1/4 X 1



### 42SGS FURRED-IN SLAVE UNIT

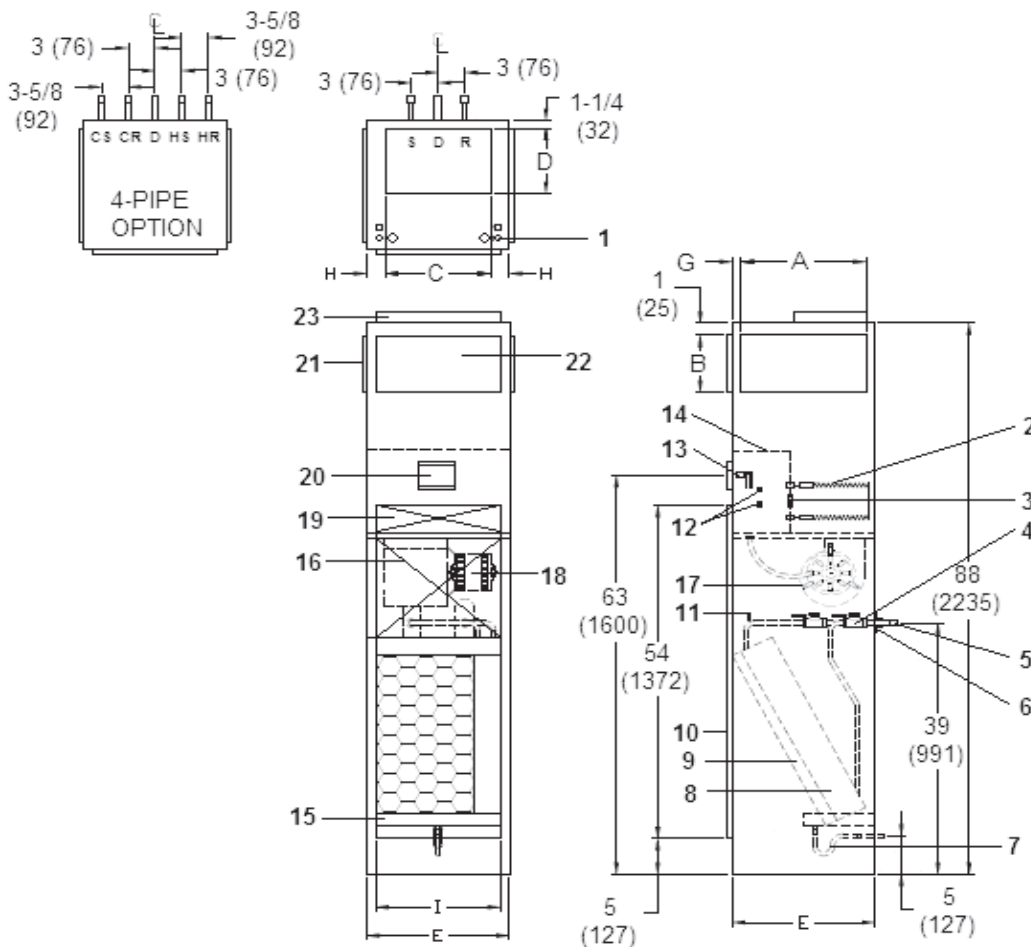

- LEGEND**
- CR — Cold Water Return
  - CS — Cold Water Supply
  - D — Drain
  - HR — Hot Water Return
  - HS — Hot Water Supply
  - R — Return
  - S — Supply

ITEM	DESCRIPTION	QTY
1	Electrical Knockouts	1
2	Strip Heater (Optional)	1
3	Limit Switch (Optional)	1
4	1/2-in. Isolation Ball Valve	2/4
5	Coil Stub Outs	2/4
6	Shipping Brace	2/4
7	Flexible Drain Tube/P-Trap	1
8	Coil 1/2-in. OD Copper Tube	1
9	Filter, Throwaway, 1-in.	1
10	Return Air Opening	1
11	Air Vent, Manual	1
12	Knockout (For Optional Remote Mounting)/ Side	2
13	Molex Connector for Field-Installed Tstat	1
14	Control Box	1
15	Drain Pan	1
16	Acoustical Bypass Panel	1
17	Blower	1
18	Motor, 3-Speed, PSC, with Quick Connect	1
19	Access Panel (Control Box)	1
20	Control Opening (Surface Mount Tstat)	1
21	Duct Collar, 1/2-in. Extension (Typical)	1/2/3
22	Supply Air Opening(s)	1/2/3
23	Top Supply Duct Collar 1-in. Extension (Optional)	1

- NOTES:**
- Units are fabricated of galvanized steel with a 16-gage galvanized fan deck.
  - Coil with valves as specified.
  - Thermostats shipped loose for field connection when ordered with unit.
  - Blower, motor, coil, valves, and filter are accessible through the return air opening.
  - Unit and control box are insulated.
  - Expansion loops in hot water heating circuits as required.
  - All dimensions are in inches. Dimensions in ( ) are in millimeters.
  - Drawing is pictorial (see unit arrangements for actual supply and return air orientation)
  - A 9-in. x 2 1/4-in. slot is provided in the inside back panel for coil connection penetration to permit expansion and contraction of risers. Care must be taken to position the risers so that coil connection is at center of slot.

UNIT MODEL	SINGLE SUPPLY			DOUBLE SUPPLY			TOP SUPPLY			DIMENSIONS - INCHES				FILTER SIZE
	A	B	SIZE	A	B	SIZE	C	D	SIZE	E	G	H	I	
42SGS03	14	8	14 X 8	14	6	14 X 6	14	10	14 x 10	17	1 1/2	1 1/2	14	12 1/2 X 24 1/4 X 1
42SGS04	14	12	14 X 12	14	6	14 X 6	14	10	14 x 10	17	1 1/2	1 1/2	14	12 1/2 X 24 1/4 X 1
42SGS06	18	10	18 X 10	18	6	18 X 6	16	12	16 x 12	20	1	2	18	16 1/4 X 26 3/4 X 1
42SGS08	18	12	18 X 12	18	6	18 X 6	16	12	16 x 12	20	1	2	18	16 1/4 X 26 3/4 X 1
42SGS10	—	—	—	22	8	22 X 8	18	16	18 x 16	24	1	3	22	20 1/2 X 29 1/4 X 1
42SGS12	—	—	—	22	8	22 X 8	18	16	18 x 16	24	1	3	22	20 1/2 X 29 1/4 X 1

42S Series Units

# Base unit dimensions (cont)



## 42SU UNIVERSAL FURRED-IN STACK

ITEM	DESCRIPTION	QTY
1	Float Switch (Optional)	1
2	Drain Pan	1
3	Flexible Drain Tube/P-Trap	1
4	Drain Knockout (3 Sides)	1 each side
5	Blower	1
6	Riser Knockouts (3 Sides)	2/4
7	1/2 in. Flare Adaptor (SWT x 37.5)	2/4
8	Coil, 1/2 in. OD Copper Tube	1
9	1 in. Filter (Factory Installed)	1
10	Manual Air Vent	1
11	Return Air Opening	1
12	Knockout (For Optional Thermostat Remote Mounting)	3
13	Molex Connector for Field-Installed Thermostat	1
14	Control Box	1
15	Duct Collar Extension (1/2 in. Side, 1 in. Top)	1/2/3
16	Outside Air Knockout (On Each Side Panel)	1
17	Electrical Knockouts (Near Each Side)	1
18	Service Switch (Optional)	1
19	Motor, 3-Speed, PSC, with Quick Connect Std	1
20	Access Panel for Motor and Blower Assembly	1
21	Access Panel (Control Box)	1
22	Control Opening Knockout (Surface Mount Thermostat)	1
23	Supply Air Knockouts (4 Sides and Top, Stitch Cut)	1/2/3

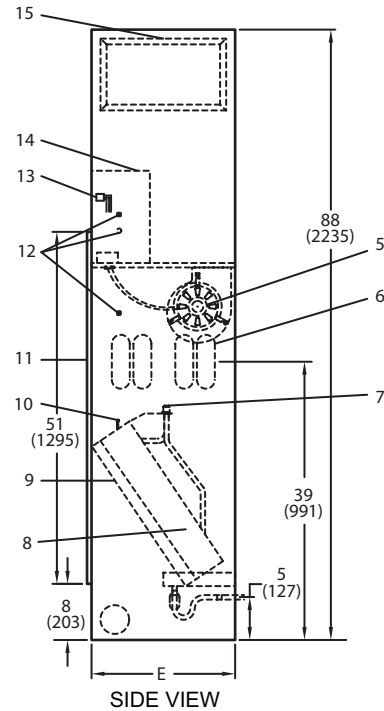
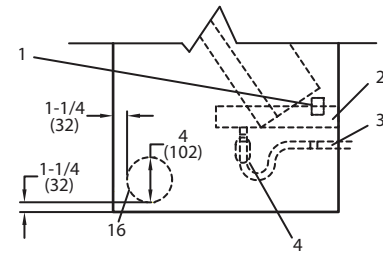
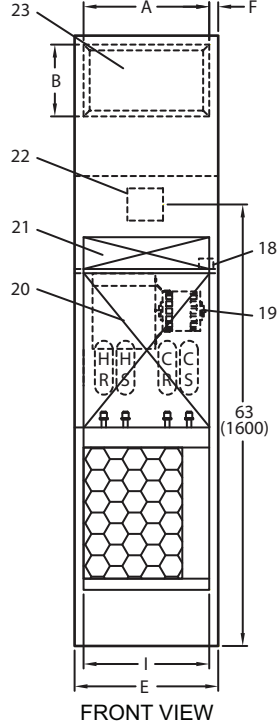
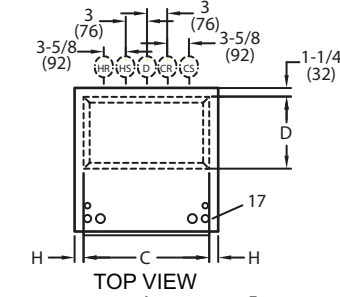

### LEGEND

- CR — Cold Water Return
- CS — Cold Water Supply
- D — Drain
- HR — Hot Water Return
- HS — Hot Water Supply
- PSC — Permanent Split Capacitor
- SWT — Sweat

### NOTES:

1. Units are fabricated of galvanized steel with a 16-gage galvanized fan deck.
2. Thermostats shipped loose for field connection.
3. Blower, motor, valves, coil, and filter are accessible through the return air opening.
4. Unit and control box are insulated with 1/2-in. (13 mm) coated fiberglass insulation.
5. All risers will ship separately from units. Riser dimensions are measured from centerline of knockout.
6. Drain knockouts on three sides of cabinet.
7. Flex hoses ship with unit.
8. Thread fittings on both ends of flex hoses must be field tightened and leak tested.
9. Return air panel not shown.
10. All dimensions are in inches (mm).

UNIT SIZE	UNIT WEIGHT* lb (kg)	DIMENSIONS, in. (mm)										FILTER SIZE in. (mm)
		Side Supply			Top Supply			E	F	H	I	
		A	B	Size	C	D	Size					
03	180 (82)	14 (356)	12 (305)	14 x 12 (356 x 305)	14 (356)	10 (254)	14 x 10 (356 x 254)	17 (432)	3 (76)	1 1/2 (38)	14 (356)	12 1/2 x 24 1/4 x 1 (318 x 616 x 25)
04	225 (102)			14 x 12 (356 x 305)	14 (356)	10 (254)	14 x 10 (356 x 254)	17 (432)	3 (76)	1 1/2 (38)	14 (356)	12 1/2 x 24 1/4 x 1 (318 x 616 x 25)
06	240 (109)	18 (457)	12 (305)	18 x 12 (457 x 305)	16 (406)	12 (305)	16 x 12 (406 x 305)	20 (508)	1 (25)	2 (51)	18 (457)	16 1/4 x 26 3/4 x 1 (413 x 679 x 25)
08	260 (118)			18 x 12 (457 x 305)	16 (406)	12 (305)	16 x 12 (406 x 305)	20 (508)	1 (25)	2 (51)	18 (457)	16 1/4 x 26 3/4 x 1 (413 x 679 x 25)
10	280 (127)	22 (559)	16 (406)	22 x 16 (559 x 406)	18 (457)	16 (406)	18 x 16 (457 x 406)	24 (610)	1 (25)	3 (76)	22 (559)	20 1/2 x 29 1/4 x 1 (521 x 743 x 25)
12	305 (138)			22 x 16 (559 x 406)	18 (457)	16 (406)	18 x 16 (457 x 406)	24 (610)	1 (25)	3 (76)	22 (559)	20 1/2 x 29 1/4 x 1 (521 x 743 x 25)

\*Unit weights are based on dry coils and minimum rows. Weights exclude packaging, valves, and other components.

### 42SU UNIVERSAL FURRED-IN STACK WITH HEATER

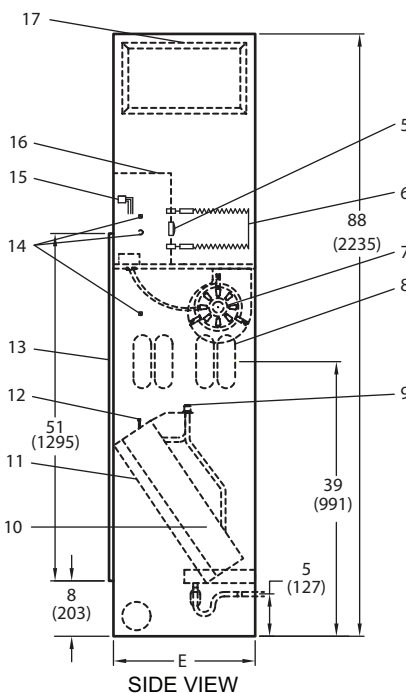
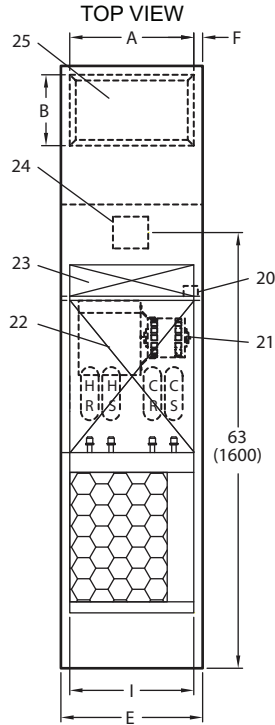
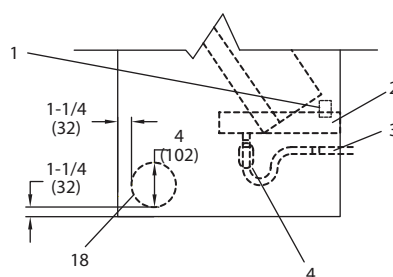
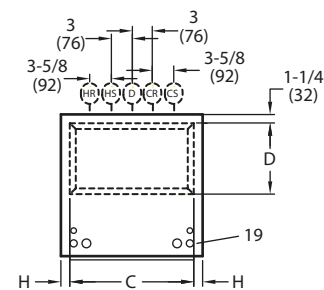

ITEM	DESCRIPTION	QTY
1	Float Switch (Optional)	1
2	Drain Pan	1
3	Flexible Drain Tube/P-Trap	1
4	Drain Knockout (3 Sides)	1 each side
5	Limit Switch (Factory Installed)	1
6	Strip Heater	1
7	Blower	1
8	Riser Knockouts (3 Sides)	2/4
9	1/2 in. Flare Adaptor (SWT x 37.5)	2/4
10	Coil, 1/2 in. OD Copper Tube	1
11	1 in. Filter (Factory Installed)	1
12	Manual Air Vent	1
13	Return Air Opening	1
14	Knockout (For Optional Thermostat Remote Mounting)	3
15	Molex Connector for Field-Installed Thermostat	1
16	Control Box	1
17	Duct Collar Extension (1/2 in. Side, 1 in. Top)	1/2/3
18	Outside Air Knockout (On Each Side Panel)	1
19	Electrical Knockouts (Near Each Side)	1
20	Service Switch (Optional)	1
21	Motor, 3-Speed, PSC, with Quick Connect Std	1
22	Access Panel for Motor and Blower Assembly	1
23	Access Panel (Control Box)	1
24	Control Opening Knockout (Surface Mount Thermostat)	1
25	Supply Air Knockouts (4 Sides and Top, Stitch Cut)	1/2/3

- LEGEND**
- CR — Cold Water Return
  - CS — Cold Water Supply
  - D — Drain
  - HR — Hot Water Return
  - HS — Hot Water Supply
  - PSC — Permanent Split Capacitor
  - SWT — Sweat

- NOTES:**
1. Units are fabricated of galvanized steel with a 16-gage galvanized fan deck.
  2. Thermostats shipped loose for field connection.
  3. Blower, motor, valves, coil, and filter are accessible through the return air opening.
  4. Unit and control box are insulated with 1/2-in. (13 mm) coated fiberglass insulation.
  5. All risers will ship separately from units. Riser dimensions are measured from centerline of knockout.
  6. Drain knockouts on three sides of cabinet.
  7. Flex hoses ship with unit.
  8. Thread fittings on both ends of flex hoses must be field tightened and leak tested.
  9. Return air panel not shown.
  10. All dimensions are in inches (mm).

UNIT SIZE	UNIT WEIGHT* lb (kg)	DIMENSIONS, in. (mm)										FILTER SIZE in. (mm)
		Side Supply			Top Supply			E	F	H	I	
		A	B	Size	C	D	Size					
03	182 (83)	14 (356)	12 (305)	14 x 12 (356 x 305)	14 (356)	10 (254)	14 x 10 (356 x 254)	17 (432)	3 (76)	1 1/2 (38)	14 (356)	12 1/2 x 24 1/4 x 1 (318 x 616 x 25)
04	227 (103)			16 x 12 (406 x 305)			16 x 12 (406 x 305)					
06	242 (110)	18 (457)	12 (305)	18 x 12 (457 x 305)	16 (406)	12 (305)	16 x 12 (406 x 305)	20 (508)	1 (25)	2 (51)	18 (457)	16 1/4 x 26 3/4 x 1 (413 x 679 x 25)
08	262 (119)			22 x 16 (559 x 406)			18 x 16 (457 x 406)					
10	282 (128)	22 (559)	16 (406)	22 x 16 (559 x 406)	18 (457)	16 (406)	18 x 16 (457 x 406)	24 (610)	1 (25)	3 (76)	22 (559)	20 1/2 x 29 1/4 x 1 (521 x 743 x 25)
12	307 (139)											

\*Unit weights are based on dry coils and minimum rows. Weights exclude packaging, valves, and other components.

42S Series Units

# Base unit dimensions (cont)

## 42SM MEGA FURRED-IN STACK

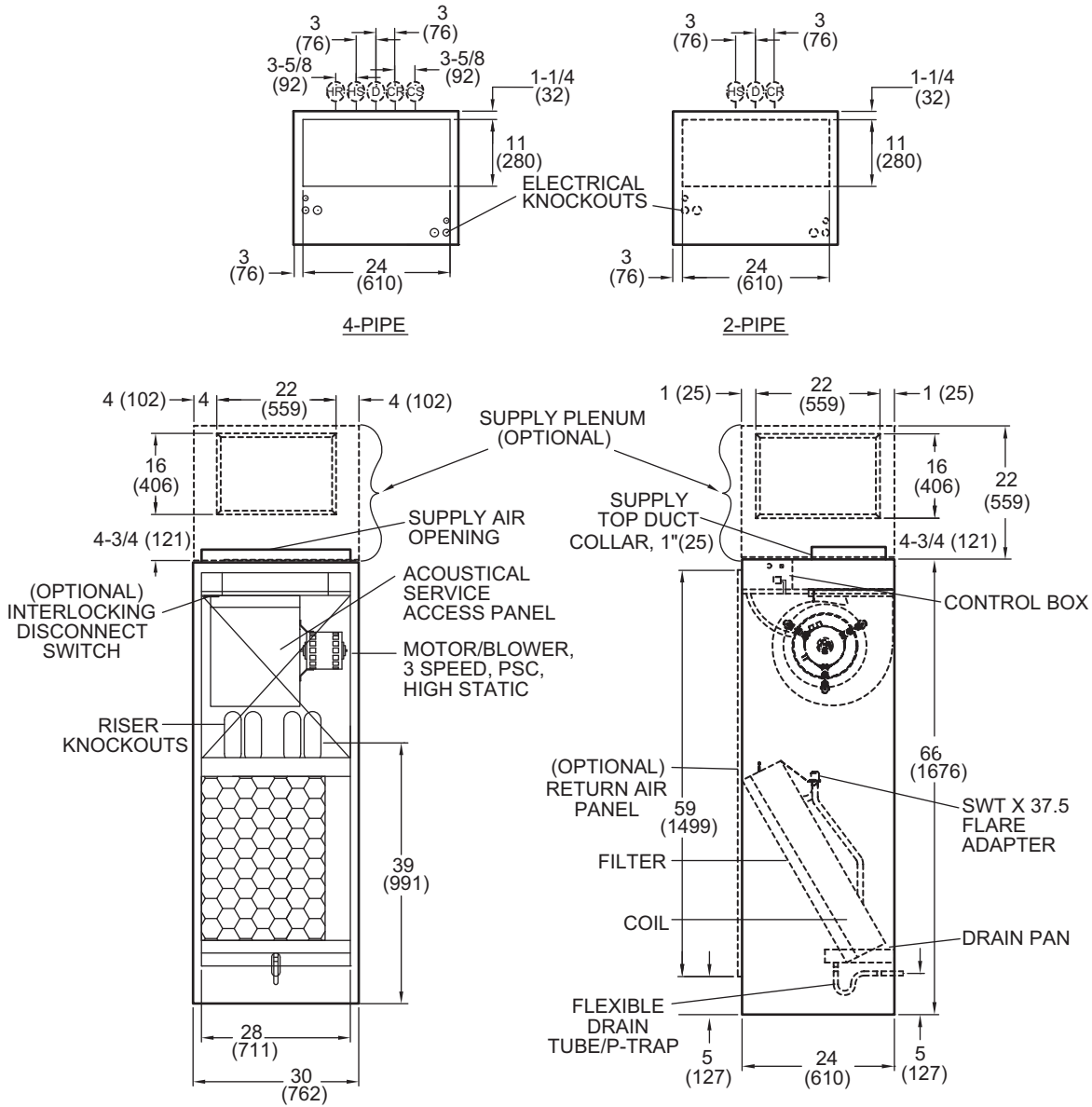

### LEGEND

- CR** — Cold Water Return
- CS** — Cold Water Supply
- D** — Drain
- HR** — Hot Water Return
- HS** — Hot Water Supply
- PSC** — Permanent Split Capacitor
- SWT** — Sweat

### NOTES:

1. Units measurements on drawings are shown in inches (millimeters).
2. Units are fabricated of galvanized steel with a 16 gage galvanized fan deck.
3. Blower, motor, valves, coil, and filter are accessible through the return air opening.
4. Unit and control box are insulated with 1/2-in. (13 mm) coated fiberglass insulation.
5. Maximum riser size is 2 1/2-in. (64 mm) diameter. If larger sizes are required, please consult the factory.
6. This drawing is pictorial. (See unit arrangements for actual supply and return air orientation.)
7. Riser length = [floor to floor + 2-in. (51 mm)]. Maximum riser length is 119-in. (3023 mm).
8. Unit shipping weight is approximately 390 lb (176 kg).

# Accessory dimensions

## 42SM OPTIONAL SUPPLY PLENUM

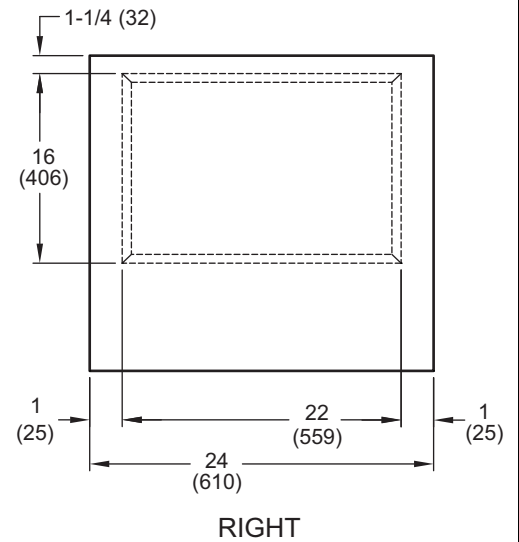
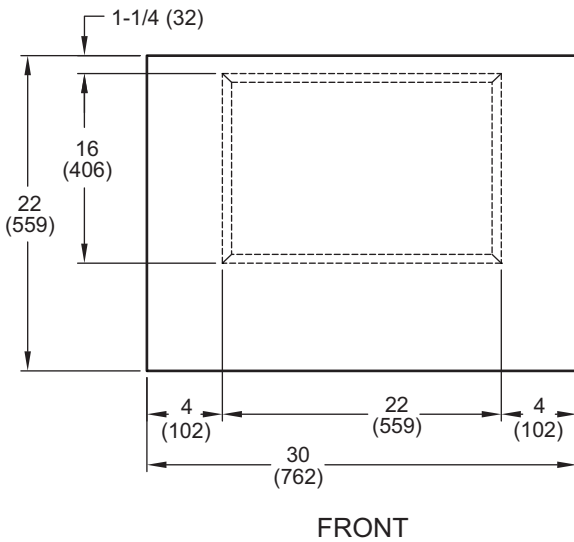
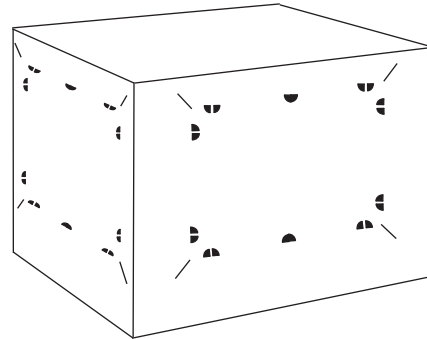
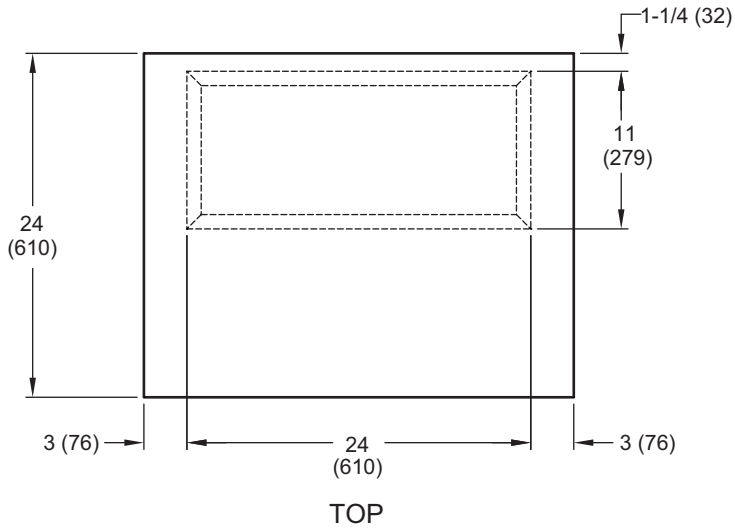

**NOTES:**

1. Plenum box adds 22-in. (559 mm) to unit height, adds 26 lb (11.8 kg) to unit weight, and is factory installed.
2. 1/4-in. closed cell insulation is standard for the plenum box.
3. Side supply is 22-in. (559 mm) x 16-in. (406 mm) on all four sides.
4. Top supply is 24-in. (610 mm) x 11-in. (279 mm) which matches unit top ducted discharge.
5. All dimensions are in inches (mm).

# Accessory dimensions (cont)

PANEL NO. 1

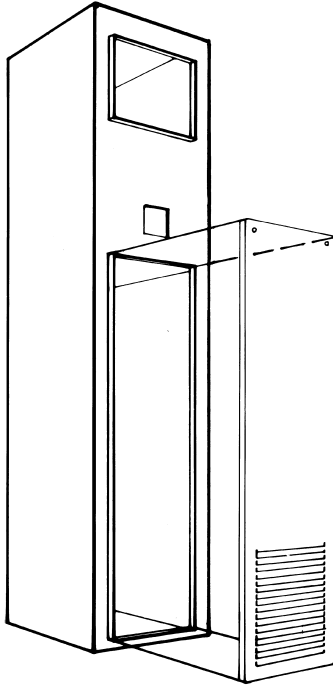

**SHORT FRAME — SURFACE MOUNTED GRILLE**  
(for use with surface or wall mounted thermostat applications)

PANEL NO. 2 WITH CONTROL DOOR

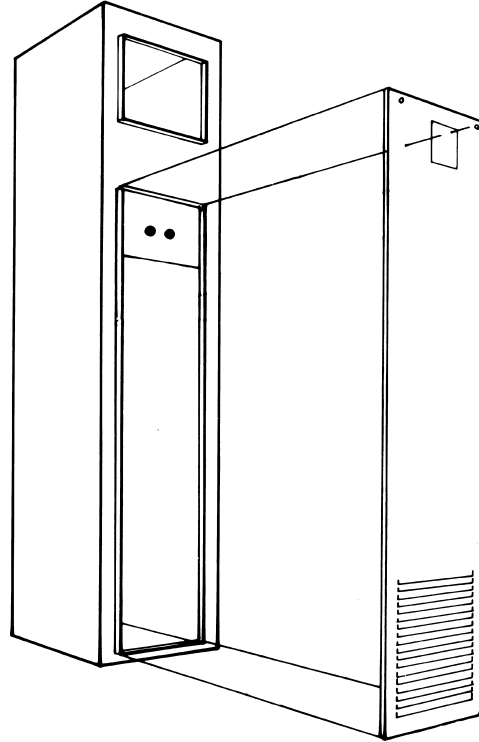

**LONG FRAME — SURFACE MOUNTED GRILLE**  
(for use with unit mounted thermostat applications)

PANEL NO. 3

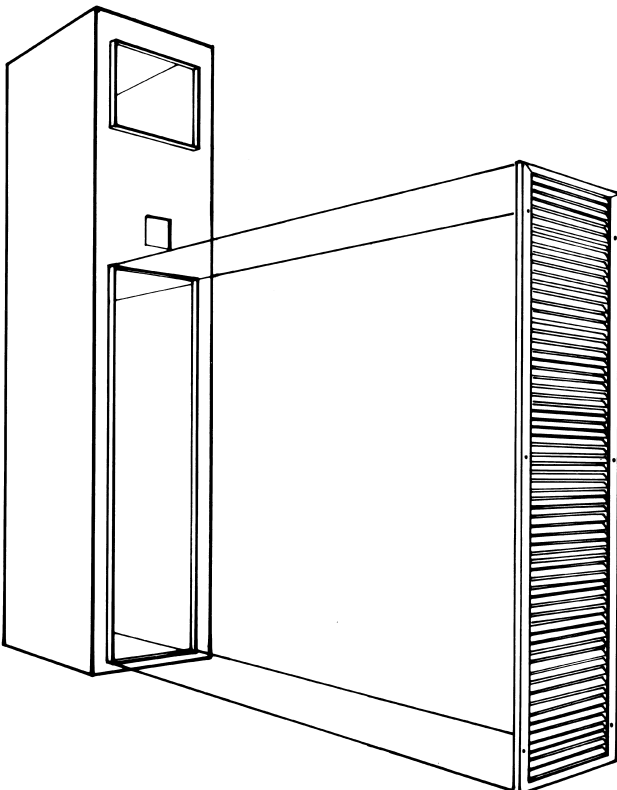

**SHORT FRAME — SURFACE MOUNTED GRILLE**  
(for use with surface or wall mounted thermostat applications)

### GRILLE LOCATIONS

UNIT	FIG.	GRILLE	ARRANGEMENTS
42SG	A	Supply	Up to 2 grilles located on any of 3 sides shown.
		Return	One grille located on any of 3 sides shown.
42SH	B	Supply	Up to 2 grilles located on any of 3 sides shown.
		Return	One grille located opposite risers.
42SJ	C	Supply	Up to 2 grilles located on any of 3 sides shown (per section).
		Return	One grille located on any of 3 sides shown (per section).
42SU	D	Supply	Up to 3 openings from any 5 knock-outs available.
		Return	One grille location.

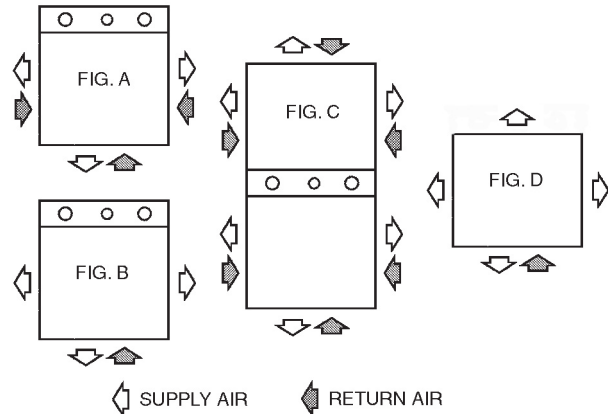

42S Series Units

**PANEL NO. 4**

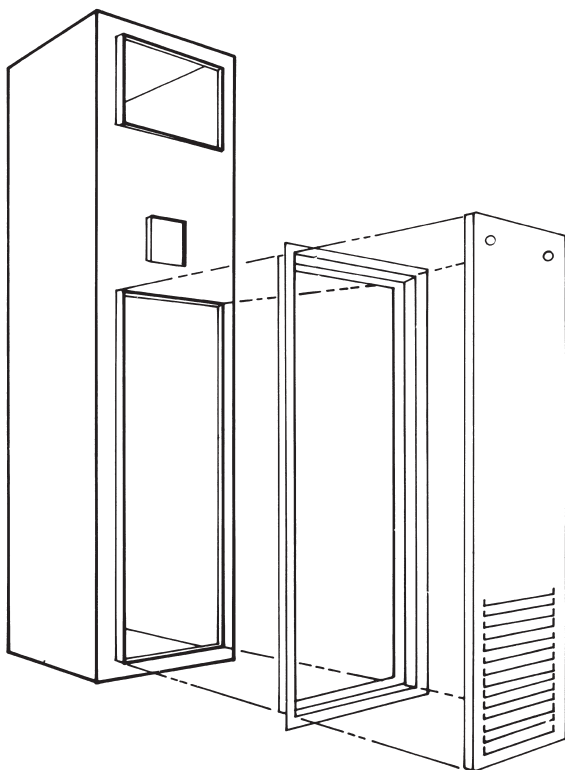

**SHORT FRAME — SURFACE MOUNTED GRILLE**  
(for use with surface or wall mounted thermostat applications)

**PANEL NO. 5 WITH CONTROL DOOR**

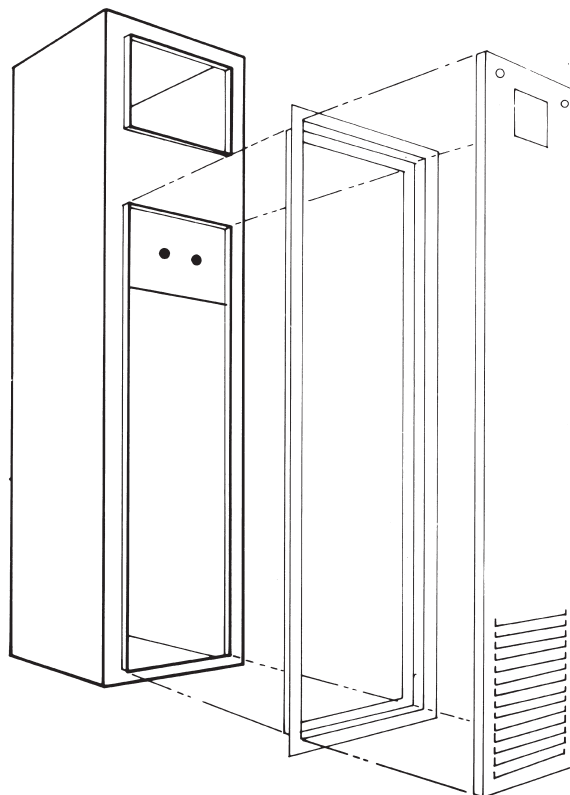

**LONG FRAME — SURFACE MOUNTED GRILLE**  
(for use with unit mounted thermostat applications)

**PANEL NO. 2 WITHOUT CONTROL DOOR**

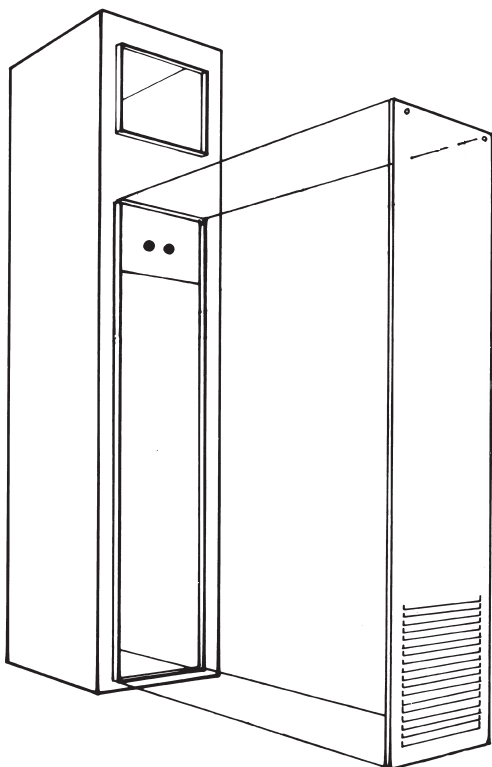

**LONG FRAME — SURFACE MOUNTED GRILLE**  
(for use with wall mounted thermostat applications)

# Accessory dimensions (cont)

## RETURN-AIR WALL PANELS FOR FURRED-IN UNITS — PANELS WITH NO FRAME

### PANEL DIMENSIONS (in.)

PANEL NO.	UNIT	UNIT SIZE	A
1	42SG,SJ, SU	03, 04	15.5
		06, 08	19.5
		10, 12	23.5
	42SM	14,16, 20	29.5
2	42SG,SJ	03, 04	15.5
		06, 08	19.5
		10, 12	23.5
3	42SG,SJ	03, 04	15.2
		06, 08	19.2
		10, 12	23.2

NOTE: Dimensions in inches.

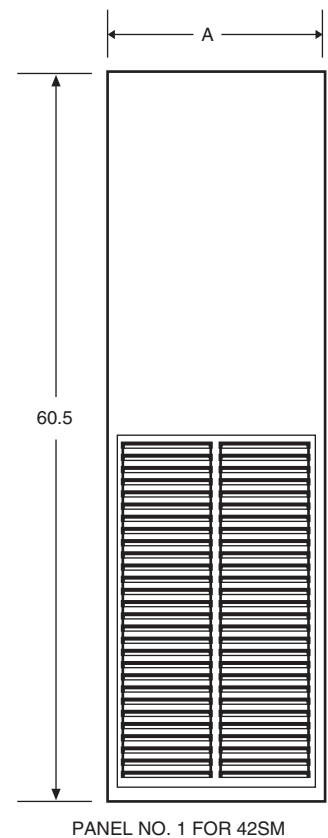
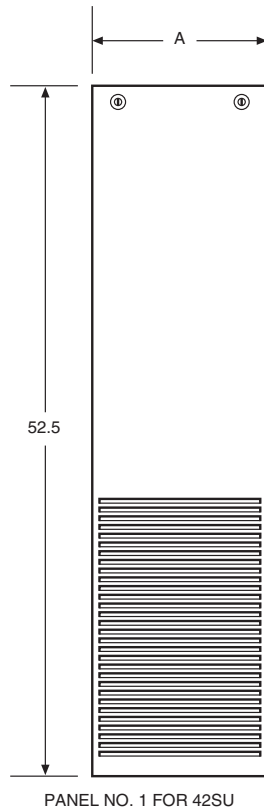
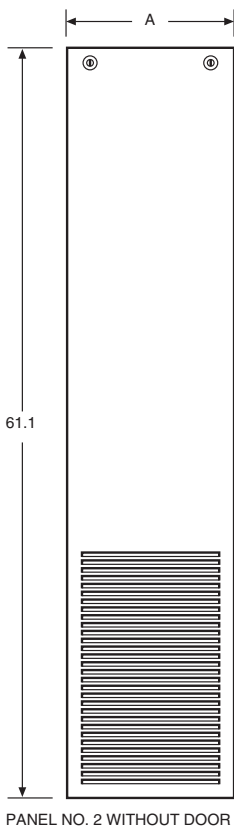
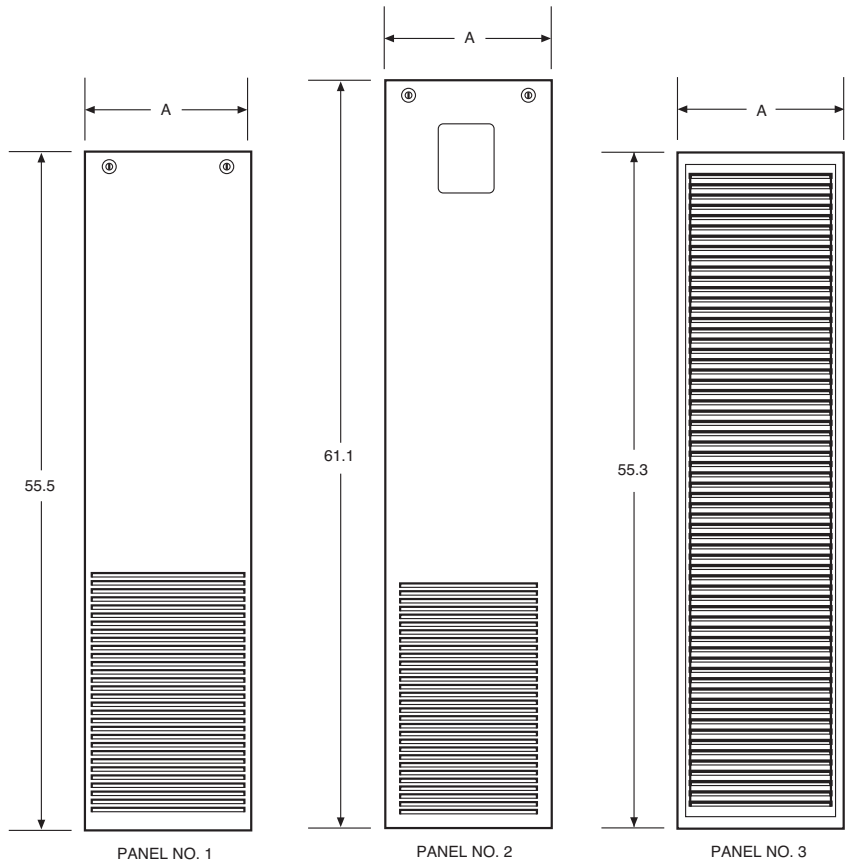

42S Series Units



### RETURN-AIR WALL PANELS FOR FURRED-IN UNITS — PANELS WITH FRAME

#### PANEL AND FRAME DIMENSIONS (in.)

PANEL NO.	UNIT	UNIT SIZE	A
4	42SG,SJ, SU	03, 04	15.1
		06, 08	19.1
		10, 12	23.1
5	42SG,SJ	03, 04	15.1
		06, 08	19.1
		10, 12	23.1

NOTE: Dimensions in inches.

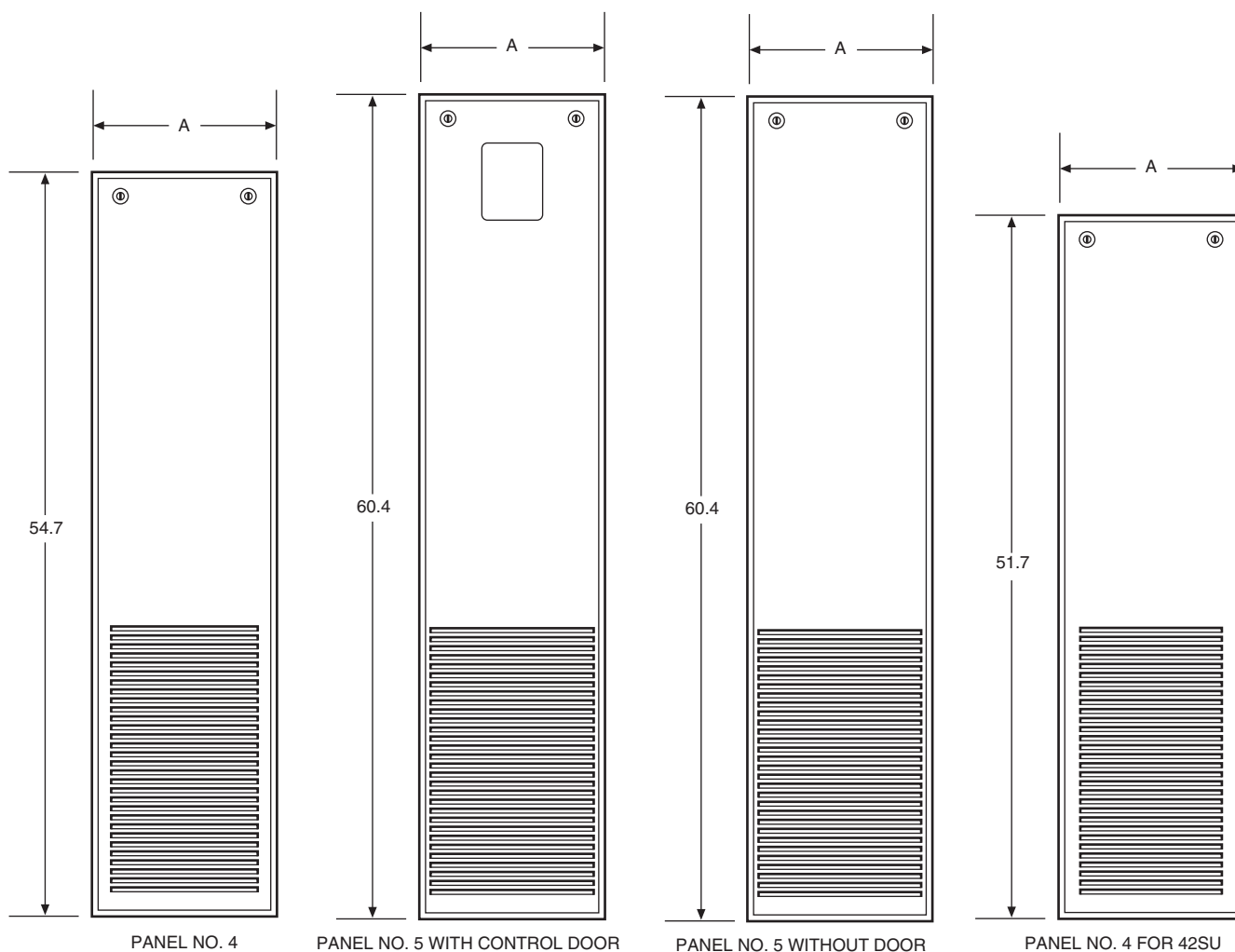

## AIR DELIVERY 42S SERIES — UNIT SIZE 03

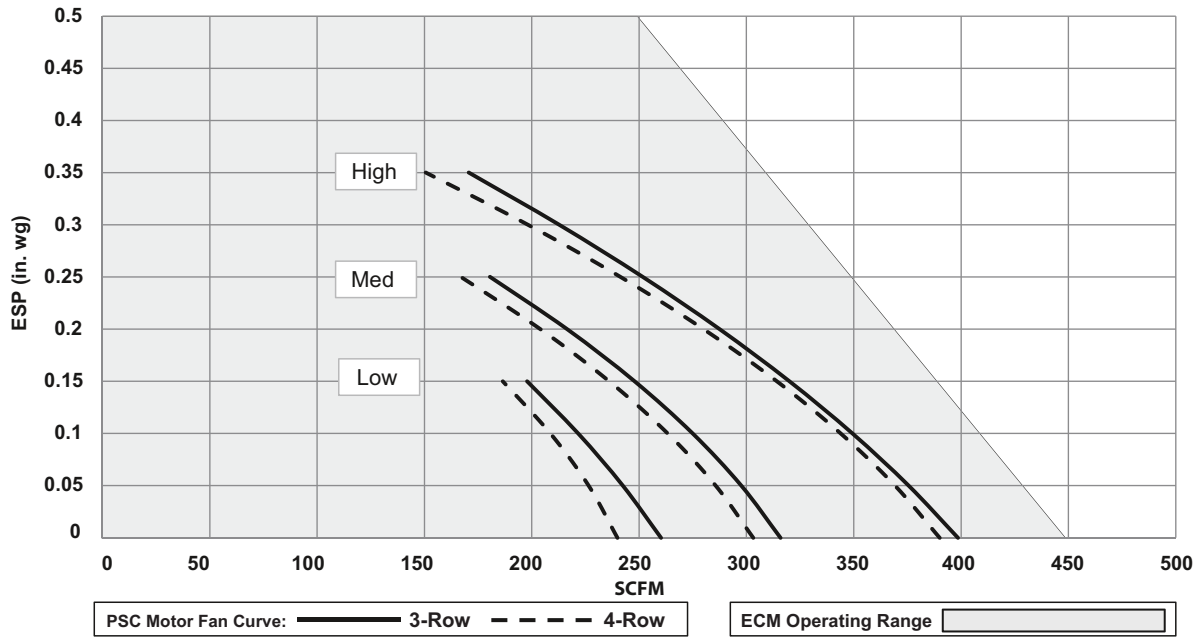

## 42S SERIES — UNIT SIZE 04

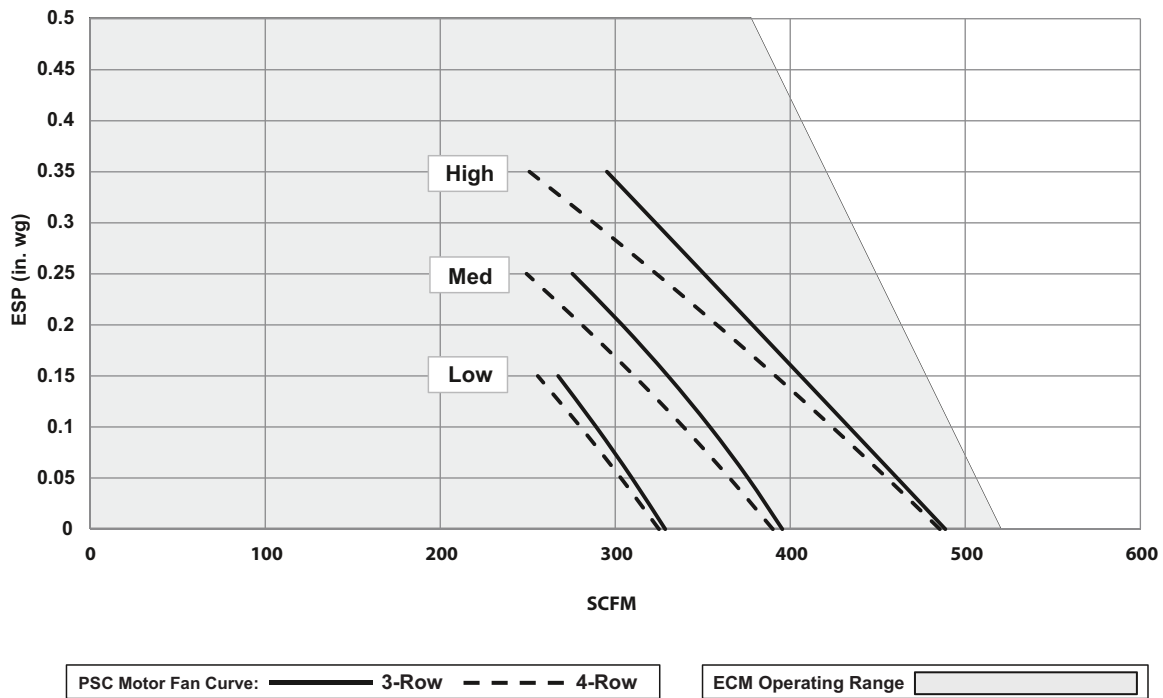

NOTE: Supply air grilled and return air panel static pressure losses are included in all fan performance curves for all sizes

LEGEND

- ECM — Electronically Commutated Motor
- ESP — External Static Pressure
- PSC — Permanent Split Capacitor
- SCFM — Square Cubic Feet Per Minute

**AIR DELIVERY (cont)**  
**42S SERIES — UNIT SIZE 06**

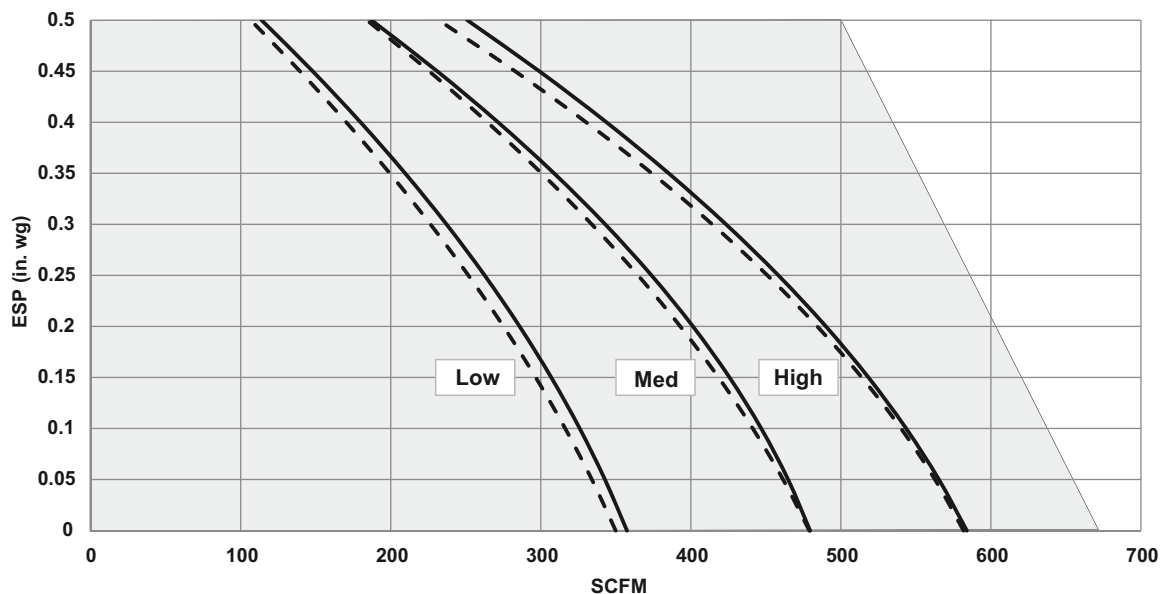

PSC Motor Fan Curve: **—** 3-Row **- - -** 4-Row      ECM Operating Range

**42S SERIES — UNIT SIZE 08**

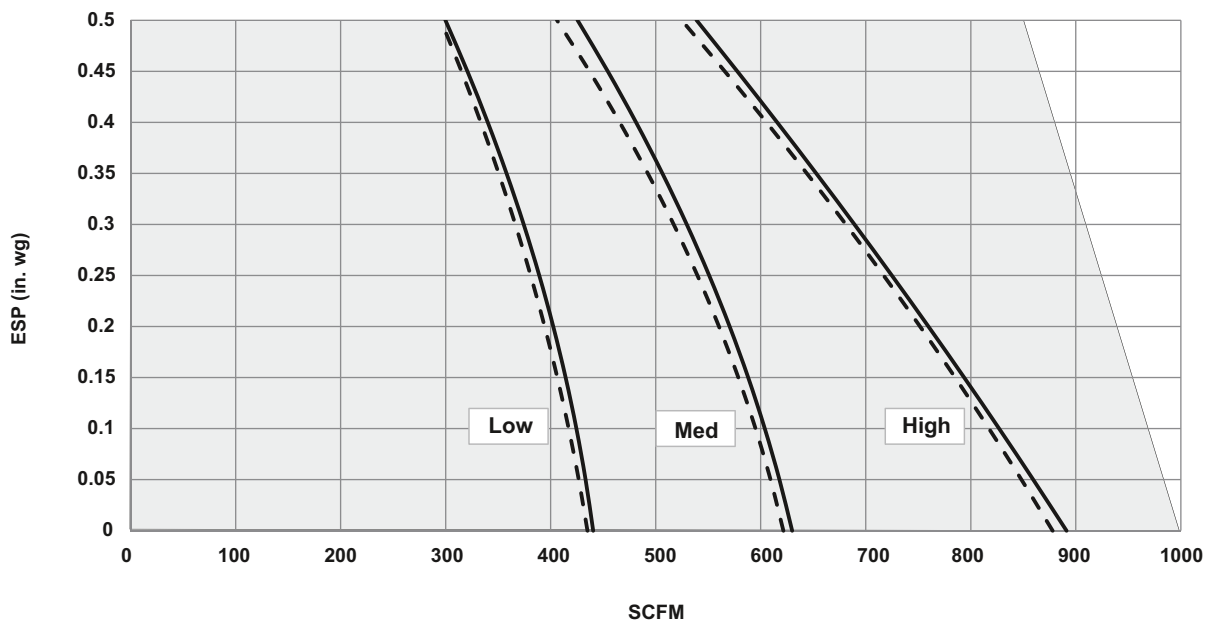

PSC Motor Fan Curve: **—** 3-Row **- - -** 4-Row      ECM Operating Range

NOTE: Supply air grilled and return air panel static pressure losses are included in all fan performance curves for all sizes

**LEGEND**

- ECM — Electronically Commutated Motor
- ESP — External Static Pressure
- PSC — Permanent Split Capacitor
- SCFM — Square Cubic Feet Per Minute

# Performance data (cont)



**AIR DELIVERY (cont)**  
**42S SERIES — UNIT SIZE 10**

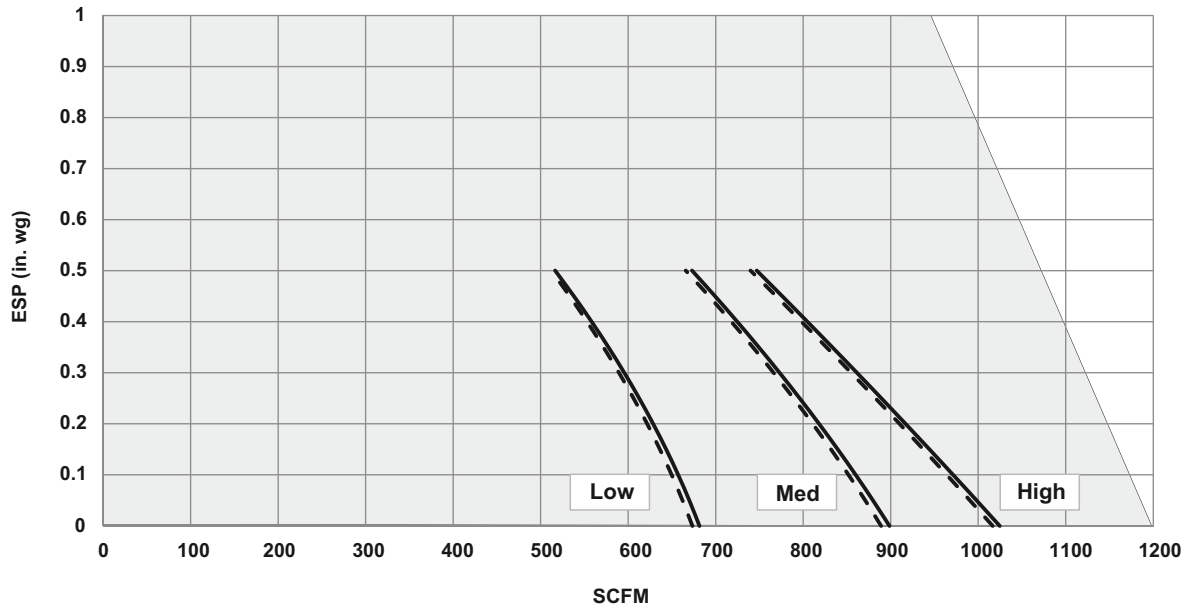

PSC Motor Fan Curve: **—** 3-Row **- - -** 4-Row      ECM Operating Range

**42S SERIES — UNIT SIZE 12**

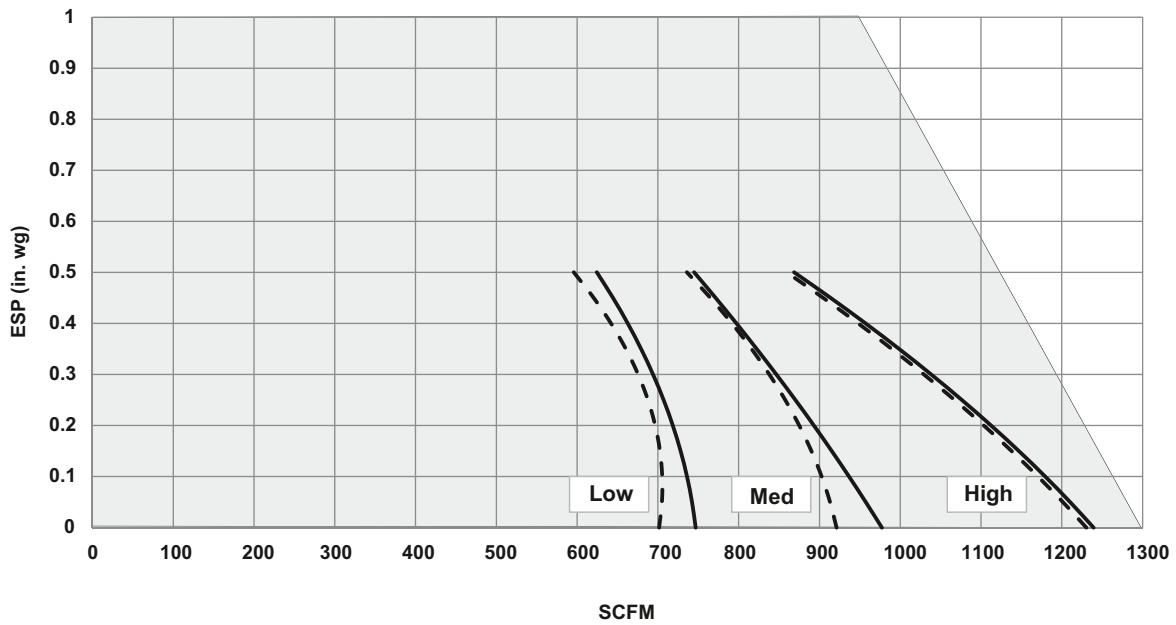

PSC Motor Fan Curve: **—** 3-Row **- - -** 4-Row      ECM Operating Range

NOTE: Supply air grilled and return air panel static pressure losses are included in all fan performance curves for all sizes

**LEGEND**

- ECM — Electronically Commutated Motor
- ESP — External Static Pressure
- PSC — Permanent Split Capacitor
- SCFM — Square Cubic Feet Per Minute

**42S Series Units**

**AIR DELIVERY (cont)**  
**42S SERIES — UNIT SIZE 14 (SMA)**

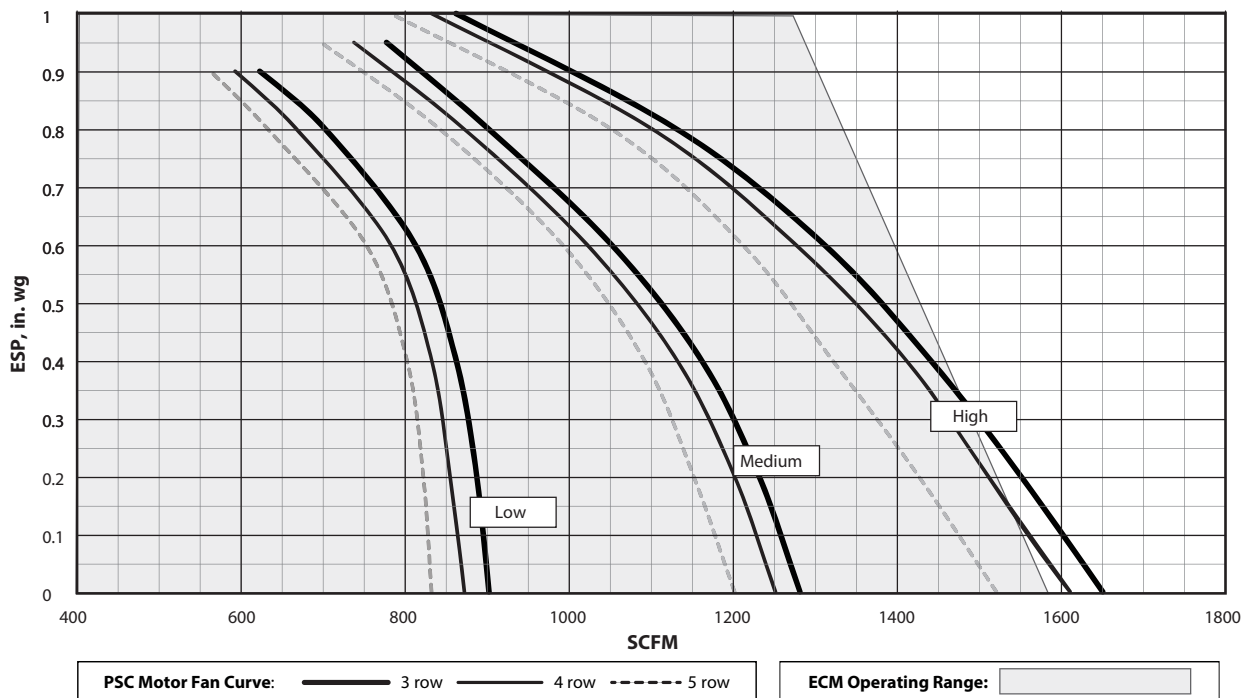

**42S SERIES — UNIT SIZE 16 (SMA)**

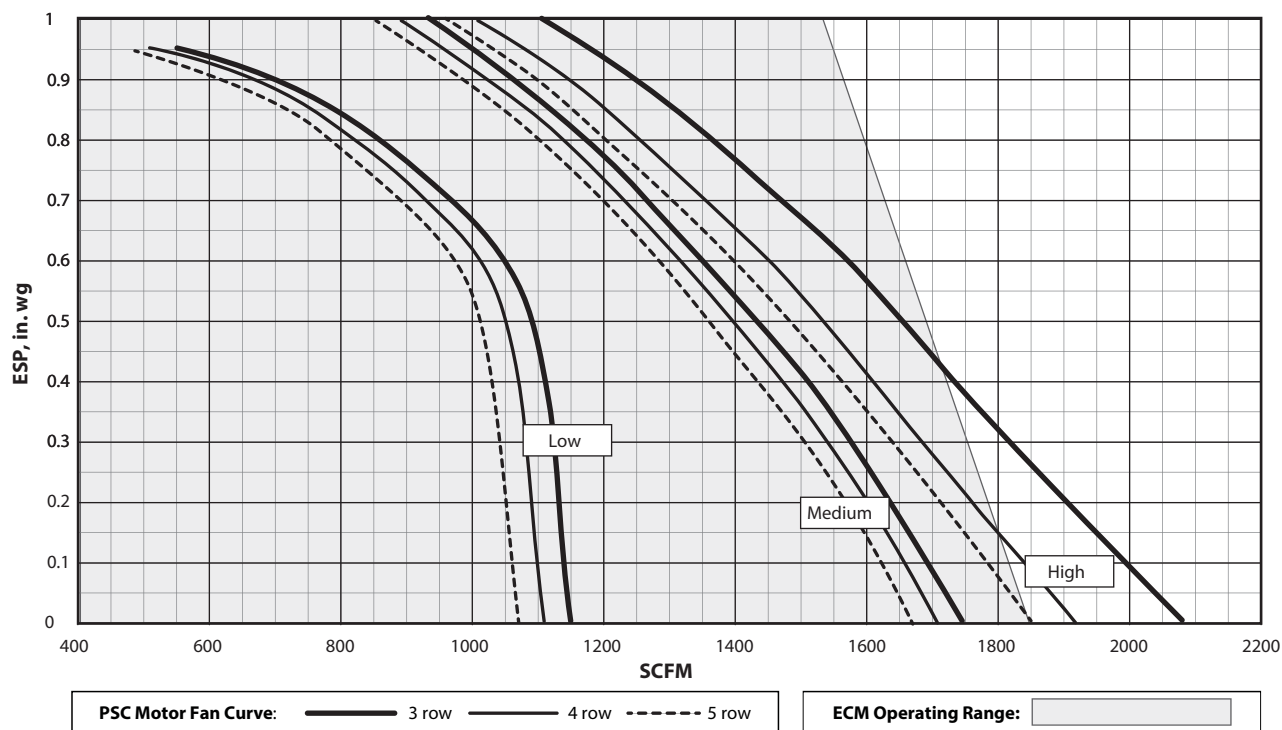

**LEGEND**

- ECM** — Electronically Commutated Motor
- ESP** — External Static Pressure
- PSC** — Permanent Split Capacitor
- SCFM** — Square Cubic Feet Per Minute

NOTE: The Mega Stack unit with an ECM can operate at any airflow and static pressure combination within the shaded area.

# Performance data (cont)



**AIR DELIVERY (cont)**  
**42S SERIES — UNIT SIZE 20 (SMA)**

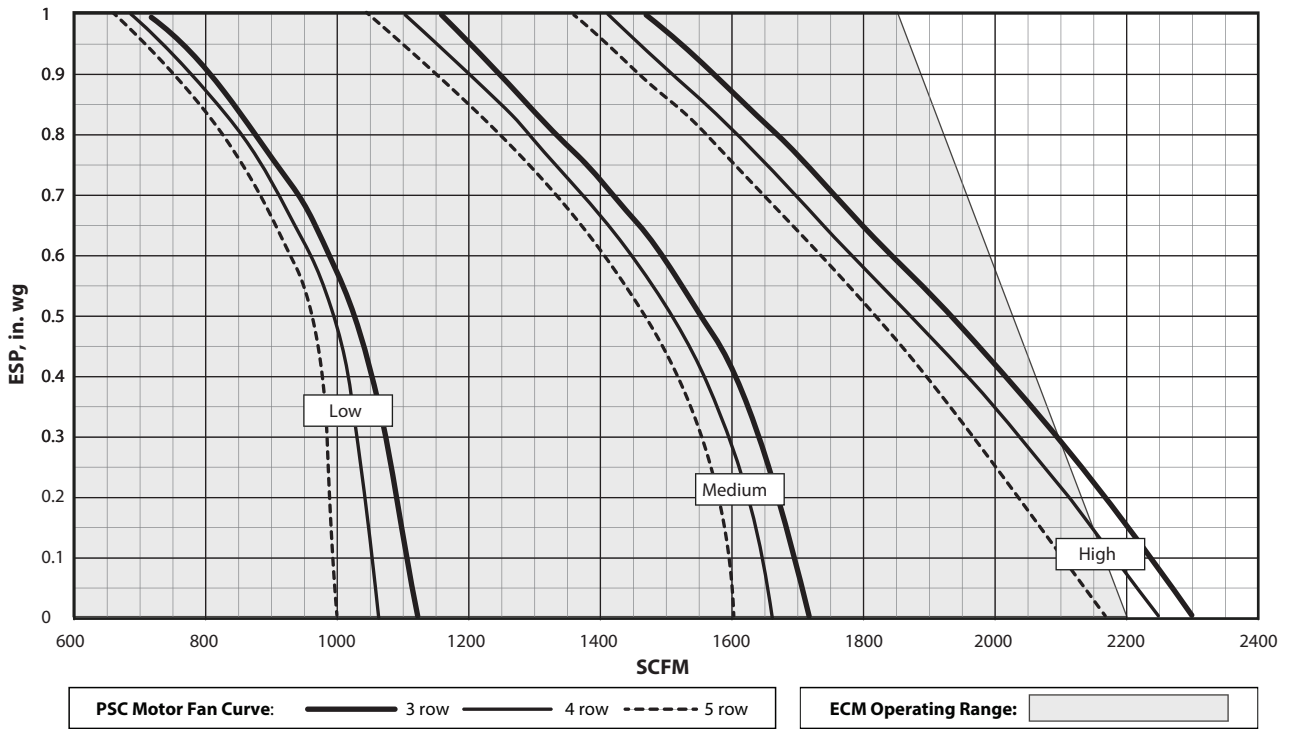

**PSC Motor Fan Curve:** — 3 row — 4 row - - - - 5 row      **ECM Operating Range:** [Shaded Area]

- LEGEND**
- ECM** — Electronically Commutated Motor
  - ESP** — External Static Pressure
  - PSC** — Permanent Split Capacitor
  - SCFM** — Square Cubic Feet Per Minute

NOTE: The Mega Stack unit with an ECM can operate at any airflow and static pressure combination within the shaded area.  
 For high-static PSC and ECM fan performance data, refer to Carrier Electronic Selection Program.

**42S Series Units**

**MAIN RISER PRESSURE DROPS**

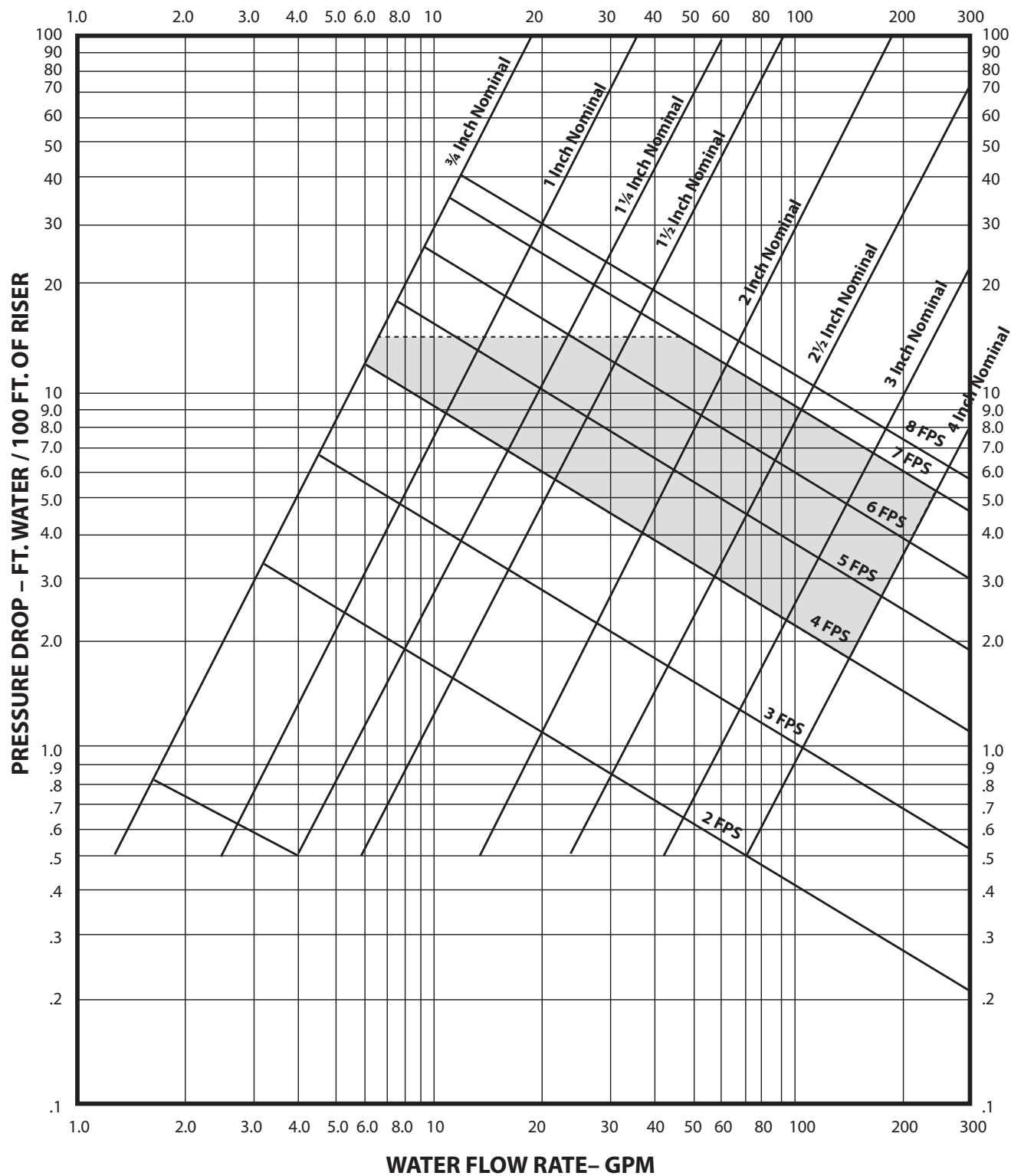

42S Series Units

## 42S PSC MOTOR DATA

V-PH-Hz	FAN SPEED	42SG,SJ,SH,SU UNIT WITH PSC											
		03			04			06			08		
		Nominal Hp	Watts	FLA	Nominal Hp	Watts	FLA	Nominal Hp	Watts	FLA	Nominal Hp	Watts	FLA
115-1-60	High	1/30	85	0.81	1/20	115	1.20	1/15	135	1.30	1/5	210	2.33
	Medium		60	0.60		70	0.70		100	1.00		145	1.40
	Low		40	0.40		50	0.50		65	0.65		90	1.00
208-1-60	High	1/30	122	0.31	1/20	114	0.60	1/15	125	0.70	1/5	185	0.96
	Medium		66	0.35		63	0.32		95	0.46		137	0.77
	Low		42	0.24		40	0.21		70	0.35		122	0.68
230-1-60	High	1/30	140	0.31	1/20	130	0.60	1/15	140	0.70	1/5	193	0.96
	Medium		76	0.36		72	0.33		105	0.46		152	0.77
	Low		50	0.25		47	0.22		85	0.38		140	0.69
277-1-60	High	1/30	80	0.30	1/20	115	0.40	1/15	135	0.60	1/6	200	0.71
	Medium		60	0.20		75	0.30		100	0.40		160	0.60
	Low		40	0.10		50	0.20		77	0.35		115	0.50

V-PH-Hz	FAN SPEED	42SG,SJ,SH,SU UNIT WITH PSC									42SM UNIT WITH HIGH-STATIC PSC					
		10			12			14			16			20		
		Nominal Hp	Watts	FLA	Nominal Hp	Watts	FLA	Nominal Hp	Watts	FLA	Nominal Hp	Watts	FLA	Nominal Hp	Watts	FLA
115-1-60	High	1/5	325	3.30	1/4	420	5.10	1/2	658	7.3	3/4	730	8.7	3/4	1051	10.8
	Medium		255	2.46		285	2.80		523	5.4		600	5.9		816	8.1
	Low		190	2.00		210	2.20		392	4.2		497	5.0		545	5.7
208-1-60	High	1/5	300	1.40	1/4	355	2.20	1/2	558	3.0	3/4	690	3.7	3/4	842	4.5
	Medium		214	1.10		235	1.20		411	2.4		553	3.1		572	3.2
	Low		162	0.86		150	0.80		280	1.7		369	2.2		370	2.2
230-1-60	High	1/5	320	1.40	1/4	405	2.20	1/2	597	3.0	3/4	753	3.8	3/4	908	4.4
	Medium		245	1.10		270	1.20		464	2.4		606	3.0		680	3.4
	Low		186	0.91		180	0.85		339	1.9		445	2.4		446	2.4
277-1-60	High	1/5	325	1.20	1/4	420	1.60	1/2	585	2.5	3/4	735	3.1	3/4	926	3.7
	Medium		270	1.00		300	1.17		458	2.0		608	2.5		716	2.9
	Low		180	0.75		200	0.90		328	1.5		464	2.0		464	2.0

**NOTES:**

- All tables above are based on PSC motors.
- All PSC motors furnished by Carrier include automatic thermal overload protection. The overload automatically resets when the temperature returns to a safe limit.
- UL approves the motor and thermal overload combination at locked rotor conditions only.
- PSC FLA information is given at 0.0 in. wg ESP. Full load condition for a PSC motor will occur at 0.0 in. wg external static. As static pressure increases, the amp draw of a PSC motor will decrease.

**LEGEND**

- ESP — External Static Pressure  
PSC — Permanent Split Capacitor  
FLA — Full Load Amps

## 42SM ECM MOTOR DATA

VOLTAGE	FAN SPEED	42SM UNIT								
		14			16			20		
		Nominal Hp	Watts	FLA	Nominal Hp	Watts	FLA	Nominal Hp	Watts	FLA
120	High	3/4	588	7.1	1	690	8.2	1	971	11.1
	Medium		350	4.4		403	5.0		554	6.7
	Low		201	2.7		228	3.0		285	3.7

**NOTES:**

- ECM motor FLA is given at 1.0 in. wg ESP. An ECM motor reaches full load condition at the units maximum external static because it has increased output to maintain airflow. An ECM motor decreases output with lower static, causing the minimum power usage to occur at 0.0 in. wg ESP.
- This data is for design purposes, and should not be used for an energy analysis.

**LEGEND**

- ECM — Electronically Commutated  
ESP — External Static Pressure  
FLA — Full Load Amps



### 42SG, SH, SJ, SU ECM MOTOR DATA

SIZE	NOMINAL HP	AMPS			
		120V	208V	230V	277V
42S*03	1/6	2.4	1.6	1.5	1.0
42S*04	1/6				
42S*06	1/6				
42S*08	1/2	8.4	4	4	3.3
42S*10	1/2				
42S*12	1/2				

### 42S ELECTRIC HEATER DATA

HEATER VOLTAGE	HEATER kW									
	1.0	1.5	2.0	3.0	4.0	5.0	6.0	8.0	10.0	12.0
	FLA									
120	8.3	12.5	16.7	25.0	—	—	—	—	—	—
208	4.8	7.2	9.6	14.4	19.2	24.0	28.8	38.5	—	—
240	4.2	6.2	8.3	12.5	16.7	20.8	25.0	33.3	45.5	—
277	3.6	5.4	7.2	10.8	14.4	18.0	21.7	28.9	36.1	43.3

**LEGEND**

**FLA** — Full Load Amps

**NOTES:**

- All heaters are single stage and single-phase. Two-stage heaters may be available with a special request.
- In all units using over 48 amps, the heating elements are subdivided and protected. Additional cost is incurred because of added components. Each circuit of the electric heater coil has an automatic reset thermal cutout with back-up high limit control and operating contactor.

- Electric heater and motor voltage must be the same and need to be ordered in conjunction with a single power source wiring option. This option, which meets NEC (National Electric Code) requirements, consists of a factory-furnished and installed junction box and fuse for 6.25 amp (max) fan and control circuit connection to a single power source. All units with electric heat must include a fused service switch. Power supply circuit to unit must be field furnished and installed in accordance with applicable codes.
- Fan coil units comply with ETL, Canadian Standards Association (CSA), and ETL of Canada standards.



## Fan Coil Unit — Horizontal Models

### HVAC Guide Specifications — 42C

Size Range: 200 to 1200 Nominal Cfm

Carrier Model Numbers:

**42CA (Furred-in)**

**42CE (Furred-in with Plenum)**

**42CG (Cabinet)**

**42CK (Furred-in, Telescoping Panel)**

#### Part 1 — General

##### 1.01 SYSTEM DESCRIPTION

Horizontal, 2-pipe or 4-pipe (or electric heat), room fan coil unit with furred-in, above ceiling cabinet for ducting, or with cabinet for exposed ceiling installations.

##### 1.02 QUALITY ASSURANCE

Units shall be tested and certified in accordance with AHRI (Air-Conditioning, Heating, and Refrigeration Institute) standard 440, latest edition. All base or standard units shall have C-ETL-US listing signifying the units have been examined by ETL and are in compliance with both the US and Canadian applicable standards. Each coil shall be factory tested for leakage at 300 psig air pressure with coil submerged in water. Insulation and adhesive shall meet NFPA (National Fire Protection Association) 90A requirements for flame spread and smoke generation. All equipment wiring shall comply with NEC (National Electrical Code) requirements.

##### 1.03 DELIVERY, STORAGE AND HANDLING

Each unit shall be individually packaged from point of manufacture. Unit shall be handled and stored in accordance with the manufacturer's instructions.

#### Part 2 — Products

##### 2.01 EQUIPMENT

###### A. General:

Factory-assembled, horizontal, blow-thru type fan coil for furred-in, exposed ceiling or ducted installations. Unit shall be complete with water coil(s), fan(s), motor(s), drain pan, and all required wiring, piping, controls and special features. Standard insulation shall be dual density fiberglass insulation.

###### B. Furred-in Base Unit (42CA):

1. Casing is heavy gage galvanized steel, lined on the inside with 1/2-in. thick fiberglass insulation, with a 1 in. long collar for supply duct connection. NO filter installed in base unit.
2. The drain pan shall be constructed of galvanized steel extending the entire length and width of the coil(s) and shall be pitched for drainage. The inside surface of the drain pan shall be coated with a 2-part closed cell foam insulation.

###### C. Furred-in Units with Plenum (42CE):

Base unit with factory-installed plenum section and 1-in. fiberglass throwaway filter as shown on equipment drawings. The plenum shall be bottom or rear air return, shall enclose the fan/motor assemblies, and shall be lined with 1/2-in. fiberglass insulation. Unit shall have a removable panel to provide access to fan/motor assemblies and unit identification label.

###### D. Cabinet Units (42CG):

Base unit with stamped discharge grille, removable bottom access panel with stamped return-air grille, filter rack and 1-in. fiberglass throwaway filter. The panel shall be fastened with tamper proof quarter-turn fasteners. The cabinet shall be coated with an Arctic White powder-coat finish.

###### E. Ceiling, Furred-in with 2-in. Telescoping Ceiling Panel (42CK):

Base unit with full galvanized upper casing, adjustable height, hinged return-air ceiling panel, and 1-in. fiberglass throwaway filter. Panel shall be coated with an Arctic White powder-coat.

###### F. Fans:

Direct-driven, double-width fan wheels with forward-curved blades shall be statically and dynamically balanced. Scrolls shall be constructed of galvanized steel. Fan wheels shall be constructed of galvanized steel.

###### G. Coils:

Standard base unit shall be equipped with a 3-row or 4-row coil for installation in a 2-pipe system. Additional coil depth and circuiting shall be provided for installation in a 4-pipe system as described in the Special Features section. All coils shall have 1/2-in. copper tubes and aluminum fins (10 fins per inch) spacing. Coil fins are mechanical bonded to tube joints. The copper tubes comply with the ASTM (American Society for Testing and Materials) B-75. The fin thickness is 0.0045-in. and tube thickness is 0.016 inch. All coils shall be leak tested with air at 300 psig under water.

###### H. Controls and Safeties:

The fan motor(s) shall be equipped with integral automatic temperature reset for motor protection.

###### I. Operating Characteristics:

1. A one-coil unit installed in a 2-pipe system shall be capable of providing heating or cooling as determined by the operating mode of the central water supply system.
2. A double-circuit coil unit installed in a 4-pipe system shall be capable of providing sequenced heating and cooling.

###### J. Electrical Requirements:

Standard unit shall operate on 115 v, single-phase, 60 Hz electric power. All internal wiring shall be in flexible conduit.

K. Motor(s):

Fan motors shall be 3-speed, 115 v, single-phase, 60 Hz, permanent split capacitor type, permanently lubricated, with sleeve bearings. Motor shall have thermal overload protection with automatic reset and be connected with quick connect electrical plug.

L. Special Features:

Certain standard features are not applicable when the features designated by \* are specified. See your local Carrier Sales Offices for amending specifications.

- \* 1. Unit coil(s) shall be equipped with automatic air vents.
- \* 2. For installation in a 4-pipe chilled water or direct expansion (DX R-410A) system, unit shall be equipped with a 3-row cooling/one-row heating split-circuit coil, a 3-row cooling/2-row heating split-circuit coil, or a 4-row cooling/one-row heating split-circuit coil as required. Coil connections to be as shown on the equipment drawings.
- \* 3. For installation on a 2-pipe chilled water or direct expansion (DX R-410A) system, units shall be equipped with a 2-row, 3-row, or 4-row, cooling/heating coil.
- \* 4. Fan motor shall be permanent split-capacitor type, 208, 220, 240, or 277-v, single-phase, 50 or 60 Hz as specified on the equipment schedule.
- \* 5. Fan motor shall be constant torque electrically commutated type, 115, 208, 220, 240, or 277-v, single phase, 50 or 60 Hz as specified on the equipment schedule. The operating sequence shall be one of the following, as specified:
  - a. 3 Discrete Speed Input, Potentiometer Field Speed Adjustment For use with a 3-speed thermostat.
  - b. 4 Discrete Speed Input, Potentiometer Field Speed Adjustment. For use with a 3-speed thermostat.
  - c. Variable Airflow for 0 to 10 VDC / 4 to 20 mA Input. Requires a 0 to 10 VDC input signal and is not compatible with a 3-speed thermostat.
- \* 6. Unit shall be equipped with electric strip heaters mounted on the entering air side of the water coil. Heaters shall include high limit cutout with auto reset and contactor. Capacity and voltage shall be as shown on the equipment schedule. When fan motor and electric heater are selected at the same voltage and connected to a single power source, a junction box and fuse shall be factory furnished and installed to protect the motor and control circuit.
- \* 7. Filter track and cleanable filter shall be installed in the plenum.
- \* 8. Drain pan shall include a second drain connection located above the main drain connection to act as an indicator that the main drain is plugged.
- \* 9. Discharge-air grille with double deflection, aluminum construction with aluminum frame shall be furnished for field installation as shown on the equipment schedule. Aluminum grilles shall have a natural anodized finish (42CG only).
- \*10. Double-deflection discharge-air grille with steel core assembly shall be factory installed as shown on equipment schedule. Grille shall be painted to match cabinet (42CG only).
- 11. Manual stop, balancing, combination balance and stop, ball type, and flow control valves shall be factory furnished and installed as indicated on the equipment drawings.
- 12. Motorized 2-way and 3-way valves shall be factory wired and assembled with tubes terminating in belled ends or unions for field attachment to the coil. Valves shall be packaged within unit to prevent shipping damage.
- 13. Heating and/or cooling wall thermostat shall be factory furnished for field installation.
- 14. Automatic changeover device(s) shall be factory wired for field installation on the supply piping.
- 15. Sequenced heating and cooling wall thermostat shall be factory furnished for field installation.
- 16. Unit shall operate on 208, 220, 240, or 277-v, single-phase, 50 or 60 Hz electrical power as specified on the equipment schedule. All wiring shall be in flexible metal conduit.
- 17. Cabinet of 42CG unit or bottom panels of 42CK unit shall be painted with the color specified on the equipment schedule.
- 18. A stainless steel drain pan shall be available for factory installation.

# Guide specifications — 42C series (cont)



19. Factory-installed insulation options shall include foil faced fiberglass or closed cell insulation.
20. Control Options:
  - a. 3-speed, 4-position manual fan switch on a wall plate for field-mounting.
  - b. Factory-installed 24-v transformer and relay board for use, with 24-v controls by others.
  - c. Carrier's Debonair® 24-v digital display programmable or non-programmable thermostat, including factory-installed 24-v transformer, relay board, and changeover sensors, as required. Provides automatic fan speed control based on demand.
  - d. Factory-Installed Carrier Fan Coil Open Controller: BACnet\* based communicating controller with pre-programmed control algorithms; including factory-installed 24-v transformer, relay board, supply air sensor, return air sensor and changeover sensor (as required). Provides automatic fan speed control based on demand.

\*BACnet is a registered trademark of ASHRAE (American Society of Heating, Refrigerating, and Air-Conditioning Engineers).

## Fan Coil Unit — Ducted Models

### HVAC Guide Specifications — 42D

Size Range: **600 to 2000 Nominal Cfm**

Carrier Model Numbers:

- 42DA (Ceiling Furred-in)**
- 42DC (Ceiling Furred-in with Plenum)**
- 42DD (Vertical with Galvanized Casing)**
- 42DE (Ceiling with Galvanized Casing)**
- 42DF (Ceiling Exposed Cabinet)**

#### Part 1 — General

##### 1.01 SYSTEM DESCRIPTION

Horizontal, 2-pipe or 4-pipe or electric heat fan coil unit for ducted installations; horizontal furred-in or exposed ceiling model, ceiling cabinet, or vertical model with galvanized casing for closet or utility room installation.

##### 1.02 QUALITY ASSURANCE

Units shall be ETL approved. All units shall be CSA (Canadian Standards Association) approved. Each coil shall be factory tested for leakage at 300 psig air pressure with coil submerged in water. Insulation and adhesive shall meet NFPA (National Fire Protection Association) 90A requirements for flame spread and smoke generation. All equipment wiring shall comply with NEC (National Electrical Code) requirements. The 42DF model shall be tested and certified in accordance with AHRI (Air-Conditioning, Heating and Refrigeration Institute) Standard 440, latest edition.

##### 1.03 DELIVERY, STORAGE AND HANDLING

Unit shall be handled and stored in accordance with the manufacturer's instructions.

#### Part 2 — Products

##### 2.01 EQUIPMENT

###### A. General:

Factory assembled, horizontal or vertical blow-thru ducted fan coil unit. Unit shall be complete with water coil(s), fan(s), motor(s), drain pan, and all required wiring, piping, controls and special features. Standard insulation shall be dual density fiberglass insulation.

###### B. Horizontal, Furred-in Base Unit (42DA):

1. Outside panels shall be galvanized steel, lined on the inside with  $\frac{1}{2}$ -in. thick fiberglass insulation and a 1-in. long collar for supply duct connection.
2. The drain pan shall be constructed of galvanized steel extending the entire length and width of coil(s) and pitched for drainage. The inside surface of the drain pan shall be coated with a 2-part closed cell foam insulation.

###### C. Horizontal Base Unit with Plenum for Concealed Installation (42DC):

Unit shall have a factory-installed, heavy-gage steel plenum section and 1-in. throwaway filter. The plenum shall be either bottom or rear return, lined with  $\frac{1}{2}$ -in. thick fiberglass insulation and include a removable panel to provide access to the fan/motor assembly.

###### D. Horizontal, Enclosed Unit for Concealed Installation (42DE):

Unit shall be constructed of galvanized steel with removable panels for access to internal components. Units have  $\frac{1}{2}$ -in. fiberglass insulation, filter track with 1-in. throwaway filter, 1-in. supply collar, and 1-in. return-air collar on rear of unit for duct connection.

###### E. Horizontal Cabinet Unit for Exposed Installation (42DF):

Unit shall be constructed of steel with Arctic White powder-coat finish. Cabinet shall be lined with  $\frac{1}{2}$ -in. fiberglass insulation. Unit shall include hinged bar type return-air grille on rear of unit with 1-in. throwaway filter and integral double deflection supply-air grille.

###### F. Vertical, Enclosed Unit for Closet Installation (42DD):

Unit shall be constructed of galvanized steel with  $\frac{1}{2}$ -in. fiberglass insulation. Unit shall include front return-air opening with 1-in. throwaway filter and 1-in. supply-air duct collar.

###### G. Fans:

Direct-driven, double-width fan wheels shall have forward-curved blades, and be statically and dynamically balanced, with scrolls and fans constructed of galvanized steel.

###### H. Coils:

Standard base unit shall be equipped with a 4-row coil for installation in a 2-pipe system. Additional coil depth and circuiting shall be provided for installation in a 4-pipe system as described in the Special Features section. All coils shall have  $\frac{1}{2}$ -in. copper tubes and aluminum fins (10 fins per inch) spacing; Coil fins are mechanical bonded to tube joints. The copper tubes comply with the ASTM (American Society for Testing and Materials) B-75. The fin thickness is 0.0045-in. and tube thickness is 0.016-in. All coils shall be leak tested with air at 300 psig under water.

###### I. Controls and Safeties:

The fan motor(s) shall be equipped with integral, automatic reset thermal overload motor protection.

## J. Operating Characteristics:

A single-circuit coil unit installed in a 2-pipe system shall be capable of providing heating or cooling as determined by the operating mode of the central water supply system. A double circuit coil unit installed in a 4-pipe system shall be capable of providing sequenced heating and cooling.

## K. Electrical Requirements:

Standard unit shall operate on 115-v, single-phase, 60-Hz electric power, and all exposed wiring shall be in a flexible conduit.

## L. Motor(s):

Fan motors shall be 3-speed permanent split capacitor type, 115 volts, permanently lubricated with sleeve bearings. Motor shall have thermal overload protection with automatic reset and be connected with quick connect electrical plug.

## M. Special Features:

Certain standard features are not applicable when the features designated by \* are specified. See your local Carrier Sales Office for amending specifications.

- \* 1. Unit coil(s) shall be equipped with automatic air vents.
- \* 2. Unit shall be equipped with a 3-row, 4-row or 6-row cooling coil for installation in a 2-pipe chilled water system or direct expansion (DX R-410A) system.
- \* 3. For installation in a 4-pipe chilled water system or direct expansion (DX R-410A) system, unit shall be equipped with either a 3-row cooling/1-row heating split circuit, or 3/2 split circuit or 4/1 split circuit, or a 4/2 split circuit or a 6/1 split circuit (except 42DD) as required.
- \* 4. Fan motor(s) shall be permanent split capacitor type, 208, 230, or 277 volts for low-static applications (42DF) or 208, 230 or 277 volts for high-static applications (42DA, DC, DD, and DE). 220-volt fan motor shall be available for 50 Hz applications.
- \* 5. Fan motor shall be constant torque electrically commutated type, 115, 208, 220, 240, or 277-v, single phase, 50 or 60 Hz as specified on the equipment schedule. The operating sequence shall be one of the following, as specified:
  - a. 3 Discrete Speed Input, Potentiometer Field Speed Adjustment. For use with a 3-speed thermostat.
  - b. 4 Discrete Speed Input, Potentiometer Field Speed Adjustment. For use with a 3-speed thermostat.
  - c. Variable Airflow for 0 to 10 VDC / 4 to 20 mA Input. Requires a 0 to 10 VDC input signal and is not compatible with a 3-speed thermostat.

## \* 6. Electric Heat:

- a. Unit shall be equipped with electric resistance strip heaters mounted on the entering air side of the water coil.
- b. Heaters shall include automatic reset high limit cutout, contactor, factory-furnished junction box and fuse to protect the motor.
- c. Heaters shall be single-stage, single-phase, 120, 208, 220, 240 or 277 volts, for 50 Hz or 60 Hz applications. Capacity shall be as shown on the equipment schedule.
- d. Control circuit for single power source connection is available and must be used when motors and heaters are of the same voltage.

## \* 7. Filter track and cleanable filter shall be installed in the plenum (42DC, DD, and DE only).

## \* 8. Drain pan shall include a second drain connection located above the main drain connection to act as an indicator that the main drain is plugged.

## 9. Removable drain pan extension (drip lip) shall be available for field installation under electric water valves.

## 10. Balancing and combination balance and stop (ball) and flow control valves shall be factory furnished and installed as indicated on the equipment drawings.

## 11. Motorized 2-way and 3-way valves shall be wired to the unit. In order to prevent shipping damage, they shall be factory assembled in the valve package. The valve packages shall terminate with belled ends or unions for field attachment to the coil.

## 12. Heating and/or cooling thermostat (SPDT) shall be factory furnished for field installation (2-pipe system).

## 13. Automatic changeover device(s) shall be factory wired for field installation on supply piping (2-pipe system).

## 14. Sequenced heating and cooling wall thermostat shall be factory furnished for field installation (4-pipe system)

## 15. Cabinet of 42DF unit shall be painted with the color specified on the equipment schedule.

## 16. A stainless steel drain pan shall be available for factory installation.

## 17. Factory-installed insulation options shall include foil faced fiberglass or closed cell insulation.

## 18. Control Options:

- a. 3-speed, 4-position manual fan switch on a wall plate for field-mounting.
- b. Factory-installed 24-v transformer and relay board for use, with 24-v controls by others.
- c. Carrier's Debonair® 24-v digital display programmable or non-programmable thermostat, including factory-installed 24-v

transformer, relay board, and changeover sensors, as required. Provides automatic fan speed control based on demand.

- d. Factory-Installed Carrier Fan Coil Open Controller: BACnet\* based communicating controller with pre-programmed control algorithms; including factory-installed 24-v transformer, relay board, supply air sensor, return air sensor and changeover sensor (as required). Provides automatic fan speed control based on demand.

\*BACnet is a registered trademark of ASHRAE (American Society of Heating, Refrigerating, and Air-Conditioning Engineers).

## Fan Coil Unit — Vertical Stack Models

### HVAC Guide Specifications — 42S

Size Range: 300 to 2000 Nominal Cfm

Carrier Model Numbers:

**42SG (Furred-in, 300 to 1200 Cfm)**

**42SH (Cabinet, 300 to 1200 Cfm)**

**42SJ (Furred-in, Back-to-Back, 300 to 1200 Cfm)**

**42SM (Mega, Furred-in, 1400 to 2000 Cfm)**

**42SU (Universal, Furred-in, 300 to 1200 Cfm)**

#### Part 1 — General

##### 1.01 SYSTEM DESCRIPTION

Stack fan coil units, 2-pipe, 4-pipe or 2-pipe with electric heat for furred-in or exposed cabinets that are floor mounted in multi-story buildings.

##### 1.02 QUALITY ASSURANCE

Units shall be tested and certified in accordance with AHRI (Air-Conditioning, Heating, and Refrigeration Institute) standard 440, latest edition. All units shall have C-ETL-US listing signifying the units have been examined by ETL and are in compliance with both the US and Canadian applicable standards. Each coil shall be factory tested for leakage at 300 psig air pressure with coil submerged in water. Insulation and adhesive shall meet NFPA (National Fire Prevention Association) 90A requirements for flame spread and smoke generation.

##### 1.03 DELIVERY, STORAGE AND HANDLING

Unit shall be handled and stored in accordance with the manufacturer's instructions.

#### Part 2 — Products

##### 2.01 EQUIPMENT

###### A. General:

Factory assembled, stack fan coil units. Units are complete with water coil(s), fan(s), motor(s), drain pan, and all required wiring, piping, controls, and special features. Standard insulation shall be dual density fiberglass insulation.

###### B. Cabinet Stack Unit (42SH):

Outside panels are made of heavy gage galvanized steel coated with powder-coat finish and are fabricated with no exposed fasteners. The interior surfaces shall be lined with 1/2-in. thick fiberglass insulation. The standard cabinet unit has factory-installed double deflection discharge grille(s) and stamped return grille. Controls are factory wired and mounted in small access panel at front of unit.

###### C. Furred-In Stack Unit (42SG):

The unit shall be constructed of heavy gage galvanized steel frame and back panel. The fan coil is for furred-in installation. These units are designed to have the wallboard applied directly to the unit surface. Units have stamped (standard) or bar-type aluminum (optional) return-air grille panel. Removable return-air grille provides access to all internal piping and wiring.

###### D. Back-To-Back Furred-In Stack Units (42SJ):

The open unit shall be constructed of heavy gage galvanized steel frame and back panel. These units are similar to the 42SG but are actually two completely separate units contained in one cabinet that share a common set of risers. Units are shipped together by a common UL one hour fire rated riser chase. These units are designed to have the wallboard directly applied to the unit surface. The interior surfaces shall be lined with 1/2-in. thick fiberglass insulation. Units have stamped (standard) or bar-type aluminum (optional) return-air grille panel. Removable return-air grille provides access to all internal piping and wiring.

###### E. Universal Furred-In Stack Units (42SU):

Units shall be constructed of heavy-gage galvanized steel frame and back panel. Interior surfaces shall be lined with standard fiberglass insulation. Units shall be designed to have wallboard applied directly to the unit surface. Unit shall have an arctic white painted stamped steel return air access panel. Removable return air/access panel shall provide access to all internal components.

###### F. Mega Furred-In Stack Units (42SM):

Units shall be constructed of heavy-gage galvanized steel frame and back panel. Interior surfaces shall be lined with standard fiberglass insulation. Units shall be designed to have wallboard applied directly to the unit surface. Return air/access opening shall provide access to all internal components.

###### G. Drain Pan:

Drain pan shall be formed of heavy gage steel and shall be coated inside with fire-retardant closed cell foam insulation. Water never touches the metal pan, eliminating the possibility of corrosion. On 42SG, SH, and SJ units the drain is factory piped to the drain riser that has a removable "P-trap" allowing easy cleaning. On 42SU and 42SM units, the drain pan shall be field piped to the drain riser with a removable/cleanable "P-trap." On 42SM units, the standard drain pan is stainless steel, externally coated with a 2-part closed cell foam insulation.

###### H. Filter:

A filter track complete with 1-in. non-woven synthetic throwaway filter shall be installed in the unit. Optional filters are available.

###### I. Fan:

1. Centrifugal fan shall be directly driven by an electric motor.
2. Fan wheel shall be double-width type with forward-curved blades and shall be statically and dynamically balanced.
3. Fan wheel and scroll shall be constructed of galvanized steel.
4. Fans shall be easily removable.



#### J. Coil:

1. Standard base unit shall be equipped with a 3-row coil for installation in a 2-pipe system. Additional coil depth and circuiting shall be provided for installation in a 4-pipe system as described in the Special Features section.
2. All coils shall have 1/2-in. copper tubes and aluminum fins with 14 fins per inch spacing; coil fins are mechanically bonded to copper tubes. The copper tubes comply with the ASTM (American Society for Testing and Materials) B-75. The fin thickness is 0.0045-in. and tube thickness is 0.016 inches. All coils are tested with air at 300 psig under water.
3. Coil shall be equipped with a manual air vent and shall be piped to supply and return risers with valves as specified on the equipment drawings. For 42SU and 42SM units, coil is not piped to risers, which shall be shipped separately.
4. Piping between hot water coil and risers shall include loops to compensate for maximum riser expansion and contraction of 1 1/2-in. on 42SG, 42SH, and 42SJ units.

#### K. Flexible Hose (Optional):

1. Construction:
  - a. Hose shall have an external component constructed of stainless steel 304L wire braid with an internal core tube of EPDM rubber.
  - b. Hoses shall have 37.5 degree female swivel crimp on fittings on either end for attachment to brass 1/2-in. male adapters.
  - c. Hoses shall be assembled with a patented process which bonds the tube to the outer braid, minimizing the possibility of the hose assembly kinking during installation.
  - d. All hoses shall be equipped with permanently installed (crimped) end fittings to eliminate the possibility of bands or clamps loosening and creating leaks.
  - e. Plated steel hose swivel fittings and brass adapters shall reduce the possibility of over-torquing.
2. Regulations:
  - a. Hoses shall meet UL-94 VO rating listed as Underwriters Laboratories Yellow Card number QMFZ2.E80017.
  - b. The 1/2-in. hoses shall be rated for a maximum working pressure of 400 psig and burst pressure of 1600 psig.
  - c. Temperature range for hose assemblies shall be -40 to 200 F.
  - d. Hoses shall be field connected.
  - e. Torque specifications for hose connections shall be 350 in.-lb +10/-0 in.-lb to prevent leaks.

#### L. Risers:

1. Standard factory-furnished and installed riser length shall be as specified on the equipment drawings.
2. Supply and return risers shall be 3/4-in. to 2 1/2-in. diameter.
3. Risers shall be Type M or L copper insulated with 1/2-in. or 3/4-in. thick closed cell insulation.
4. Optional riser chase on 42SGA for application of wall board directly to the chase.

#### M. Valves:

The factory furnished or installed risers shall have ball valves except on the drain riser.

#### N. Controls and Safeties:

1. Controls:  
Unit shall come with no controls unless control package is selected.
2. Safeties:  
Unit fan motor shall be equipped with thermal overload protection with automatic reset.

#### O. Operating Characteristics:

1. A unit with a conventional coil, installed in a 2-pipe system, shall be capable of providing heating or cooling as determined by the operating mode of the central water supply system.
2. A unit with a row-split coil, installed in a 4-pipe system, shall be capable of providing sequenced heating and cooling.

#### P. Electrical Requirements:

Standard unit shall operate on 115-v, single-phase, 60 Hz electrical power supply. All externally exposed wiring shall be in flexible conduit.

#### Q. Motor:

1. Standard fan motor shall be 3-speed, 115-v, single-phase, 60 Hz, permanent split capacitor type, factory mounted on the blower housing.
2. Bearings shall be permanently lubricated sleeve type.
3. Motor shall be equipped with quick connect electrical plug.
4. Motor shall have thermal overload protection with automatic reset.

#### R. Special Features:

Certain standard features are not applicable when the features designated by \* are specified.

- \* 1. Unit coil shall be equipped with automatic air vents.
- \* 2. Unit shall be equipped with a 3-row, 4-row, or 5-row (42SM) coil for installation in a 2-pipe system.

# Guide specifications — 42S series (cont)



- \* 3. For installation in a 4-pipe system, unit shall be equipped with:
  - a. A 3/1, 3/2 or 4/1 row-split coil, as shown on equipment drawings for cooling and heating.
  - b. Two each supply and return risers and one drain riser.
  - c. Two ball valves, 2 circuit setters and two 2-way motorized valves.
  - d. Motorized control valves shall be rated at 300 psi with 150 psi close-off pressure differential, and rated to operate with fluid temperatures from 40 to 180 F. Normally closed valves shall be powered open with spring driven closure.
- \* 4. Unit shall be equipped with 3-way motorized valves.
- 5. Fixed flow valve(s) shall be factory installed as shown on the equipment drawings.
- \* 6. Motor shall be 3-speed, single-phase, 60 Hz permanent split capacitor type for 208, 230 or 277 volts or 50 Hz permanent split capacitor type for 220 volts.
- 7. Motor shall be ECM (electronically commutated motor) motor for single-phase, 60 Hz, 115, 208, 230, or 277 V. The operating sequence shall be one of the following, as specified:
  - a. 3 Discrete Speed Input, Potentiometer Field Speed Adjustment. For use with a 3-speed thermostat.
  - b. 4 Discrete Speed Input, Potentiometer Field Speed Adjustment. For use with a 3-speed thermostat.
  - c. Variable Airflow for 0 to 10 VDC / 4 to 20 mA Input. Requires a 0 to 10 VDC input signal and is not compatible with a 3-speed thermostat.
- \* 8. Double-deflection aluminum finish supply grille(s) shall be finished for field installation.
- 9. Double-deflection aluminum finish supply grille(s) with opposed blade damper shall be furnished for field installation on two or more discharge units.
- 10. Ceiling skirts for exposed stack units shall be provided for field trim and installation.
- 11. A fresh-air opening shall be provided as shown on the equipment drawings.
- \* 12. One-in. thick cleanable filters or pleated MERV 8 filters, shall be installed in the filter track.
- \* 13. Unit shall be equipped with nichrome wire electric strip heaters for total or auxiliary electric heat as specified on the equipment schedule.
  - a. Heaters shall be protected by an automatic reset safety cutout switch and a fusible link.
  - b. Heater capacity shall be as specified on the equipment schedule.
  - c. Heaters shall be single phase, 60 Hz for 120, 208, 240 or 277 volts as specified on the equipment schedule.
  - d. Electric heaters shall include thermal overload protection with fusible link back-up.
  - e. Units with electric heat shall also include blower motor and control sub-fusing.
- 14. Fused or unfused service switch shall be provided. Switch shall be suitable for single phase, 60 Hz service for 115, 208, 240 or 277 volts as specified on the equipment schedule.
- 15. Panels of 42SH unit shall be painted with the color specified on the equipment schedule.
- 16. Return air panels shall be supplied as shown on the equipment drawings.
- 17. Tamper-proof fasteners (Allen head) shall be installed on the access panels on cabinet models.
- 18. A stainless steel drain pan shall be available for factory installation.
- 19. Factory-installed insulation options shall include foil faced fiberglass or closed cell insulation (42SG,SH,SJ,SM only).
- 20. Control Options:
  - a. Factory installed 24-v transformer and relay board for use, with 24-v controls by others.
  - b. Carrier's Debonair® 24-v digital display programmable or non-programmable thermostat, including factory-installed 24-v transformer, relay board, and changeover sensors, as required. Provides automatic fan speed control based on demand.
  - c. Factory-Installed Carrier Fan Coil Open Controller: BACnet\* based communicating controller with pre-programmed control algorithms; including factory-installed 24-v transformer, relay board, supply air sensor, return air sensor, and changeover sensor (as required). Provides automatic fan speed control based on demand.

\*BACnet is a registered trademark of ASHRAE (American Society of Heating, Refrigerating, and Air-Conditioning Engineers).

## Fan Coil Unit — Vertical Models

### HVAC Guide Specifications — 42V

Size Range: **200 to 1200 Nominal Cfm**

Carrier Model Numbers:

**42VAC (Furred-in)**

**42VBC (Cabinet)**

**42VCA (Furred-in, Lowboy, 200 to 600 cfm)**

**42VEA (Cabinet, Lowboy, 200 to 600 cfm)**

**42VFC (Cabinet, Slant Top)**

**42VGA (Furred-in, Wall, 150 and 300 cfm)**

#### Part 1 — General

##### 1.01 SYSTEM DESCRIPTION

Vertical, 2-pipe or 4-pipe, or electric heat, room fan coil unit for furred-in, or cabinet floor mounted installation. (42VCA and VEA are low profile units.)

##### 1.02 QUALITY ASSURANCE

Unit shall be tested and certified in accordance with AHRI (Air-Conditioning, Heating, and Refrigeration Institute) Standard 440, latest edition, and base unit ETL certified. All units shall have C-ETL-US listing signifying the units have been examined by ETL and are in compliance with both the US and Canadian applicable standards. (Units with special features may not have ETL certification.) Each coil shall be factory tested for leakage at 300 psig air pressure with coil submerged in water. Insulation and adhesive shall meet NFPA (National Fire Protection Association) 90A requirements for flame spread and smoke generation. Adhesive shall be certified according to the GREENGUARD Indoor Air Quality Certification for Low Emitting Products.

##### 1.03 DELIVERY, STORAGE AND HANDLING

Each unit shall be individually packaged from point of manufacture. Unit shall be handled and stored in accordance with the manufacturer's instructions.

#### Part 2 — Products

##### 2.01 EQUIPMENT

###### A. General:

Factory-assembled, vertical, blow-thru type floor-mounted fan coil for furred-in or exposed installations. Unit shall be complete with water coil, fan(s), motor(s), drain pan, and all required wiring, piping, controls and special features. Standard insulation shall be dual density fiberglass insulation.

###### B. Base Unit (42VAC, VCA):

1. Outside panels are made of heavy gage galvanized steel. Lined on the inside with  $\frac{1}{2}$ -in. thick fiberglass insulation, with a 1 in. long collar for top supply duct connection. Units shall be supplied with a 1-in. fiberglass throwaway filter.
2. The drain pan shall be constructed of 18-gage galvanized steel extending the entire length and width of the coils and pitched for drainage. The painted galvanized interior drain pan shall be externally coated with 2-part closed cell foam

insulation. (Stainless steel pans shall be externally coated).

###### C. Cabinet Models (42VBC, VEA, VFC):

1. Cabinet models shall be coated with an Arctic White powder-coat finish, and include a 1-in. fiberglass throwaway filter.
2. Cabinet models shall be free standing with 2 access doors. A stamped supply-air grille shall be included in the top of the cabinet.
3. The 42VFC top panel shall slope down from back to front at an angle of 25 degrees. Standard stamped grille shall provide a discharge into the room at a nominal 60 degrees from the vertical.

###### D. Furred-In Model (42VGA):

1. Cabinet shall be fabricated of heavy gage galvanized steel with  $\frac{1}{2}$ -in. thick fiberglass insulation. Cabinet shall be coated with an Arctic White powder-coat finish. Removable front panel shall provide service access and shall include stamped supply and return-air grilles.
2. Combination condensate pan and fan deck shall be insulated with closed cell fire-retardant foam.

###### E. Fans:

Direct-driven, double-width fan wheels shall have forward-curved blades and shall be statically and dynamically balanced. Scrolls and fan wheels shall be constructed of galvanized steel.

###### F. Coils:

Standard base unit shall be equipped with a 3-row (42VAC, VBC, VFC units) or 2-row coil (42VCA, VEA, VCA units) for installation in a 2-pipe system. Additional coil depth and circuiting shall be provided for installation in a 4-pipe system as described in the Special Features section. All coils shall have  $\frac{3}{8}$ -in. copper tubes and aluminum fins (12 fins per inch for 42VAC, VBC, VFC and 10 fins per inch for 42VCA, VEA, VCA) spacing; Coil fins are mechanical bonded to tube joints. The copper tubes comply with the ASTM B-75. The fin thickness is 0.0045 in. and tube thickness is 0.014 in. All coils shall be leak tested with air at 300 psig under water.

###### G. Controls and Safeties:

Internal wiring from motor and valves shall be in flexible metal conduit, terminating in the junction box.

###### H. Operating Characteristics:

1. A one-coil unit installed in a 2-pipe system shall be capable of providing heating and cooling as determined by the operating mode of the central water supply system.
2. A double-circuit coil unit installed with a 4-pipe system shall be capable of providing sequenced heating and cooling.

# Guide specifications — 42V series (cont)



## I. Electrical Requirements:

Standard unit shall operate on 115 v, single-phase, 60 Hz electric power. All internal wiring shall be in flexible conduit.

## J. Motor(s):

Fan motor(s) shall be 3-speed, 115 v, single-phase, 60 Hz, permanent split capacitor type permanently lubricated, with sleeve bearings. Motors shall have integral automatic temperature reset for motor protection.

## K. Special Features:

Certain standard features are not applicable when the features designated by \* are specified. See your local Carrier Sales Office for amending specifications.

- \* 1. Unit coil(s) shall be equipped with automatic air vents.
- \* 2. For installation in a 2-pipe system, unit shall be equipped with a 3-row or 4-row cooling/heating coil (42VAC,VBC,VFC units) or a 3-row cooling/heating coil (42VCA,VEA).
- \* 3. For installation in a 4-pipe system, 42VAC, VBC, VFC units shall be equipped with a 3-row cooling/one-row heating split-circuit coil, a 3-row cooling/2-row heating split-circuit coil or a 4-row cooling/one-row heating split-circuit coil as required. The 42VCA,VEA units shall be equipped with a 2-row cooling/one-row heating split-circuit coil.
- \* 4. Fan motor shall be permanent split-capacitor type, 208, 220, 240, or 277-v, single-phase, 50 or 60 Hz as specified on the equipment schedule.
- \* 5. Fan motor shall be constant torque electrically commutated type, 115, 208, 220, 240, or 277-v, single phase, 50 or 60 Hz as specified on the equipment schedule. The operating sequence shall be one of the following, as specified:
  - a. 3 Discrete Speed Input, Potentiometer Field Speed Adjustment. For use with a 3-speed thermostat.
  - b. 4 Discrete Speed Input, Potentiometer Field Speed Adjustment. For use with a 3-speed thermostat.
  - c. Variable Airflow for 0 to 10 VDC / 4 to 20 mA Input. Requires a 0 to 10 VDC input signal and is not compatible with a 3-speed thermostat.
- \* 6. Unit shall be equipped with electric resistance sheath type heaters mounted on the leaving air side of the water coil. Heaters shall include high limit cutout with auto reset and contactor. Capacity and voltage shall be as shown on the equipment schedule. When fan motor and electric heater are selected at the same voltage and connected to a single power source, a junction box and fuse shall be factory furnished and installed to protect the motor and control circuit. Unit height on 42VCA and VEA shall be increased by 2 in. to accommodate heaters.
- \* 7. Cleanable filter shall be factory installed in the filter track.
- \* 8. Leveling legs shall be factory installed on the unit and permit a maximum adjustment of  $\frac{3}{4}$  inch.
- 9. Switch box complete with switch shall be factory installed on the unit.
- 10. Discharge-air grille with double deflection aluminum construction as shown on the equipment schedule shall be furnished for field installation (42VAC,VCA units).
- 11. Discharge-air grille with double deflection steel or aluminum construction shall be shipped installed in the unit (42VBC,VFC,VEA units). Steel grilles shall be painted to match cabinet. Aluminum grilles shall be a natural anodized finish.
- 12. Reverse-stamped grille (42VBC, VFC units) shall provide a discharge into the room at a nominal 30 degrees from vertical.
- 13. Manual stop, balancing, combination balance and stop (ball type), and flow control valves shall be factory furnished and installed as indicated on the equipment drawings.
- 14. Motorized 2-way and 3-way valves shall be factory assembled and wired to unit with tubes terminating in belled ends or unions for field attachment to the coil. Valves shall be packaged within the unit to prevent shipping damage.
- 15. Heating and/or cooling wall thermostat shall be factory furnished for field installation.
- 16. Heating and/or cooling thermostat shall be factory wired and installed.
- 17. Automatic changeover device(s) shall be factory wired for field installation on the supply piping.
- 18. Sequenced heating and cooling wall thermostat shall be factory furnished for field installation.
- 19. Sequenced heating and cooling thermostat shall be factory wired and installed.
- \*20. Tamper-proof fasteners (Allen head) shall be installed on front panel and access doors on cabinet models.
- \*21. Cabinet shall be painted with the color specified on the equipment schedule.
- \*22. Factory-installed outside-air damper shall be manually adjustable through the return air opening or shall be arranged for remote manual adjustment, complete with linkage and electric motor to open damper when fan is on. Or, unit shall have a  $\frac{3}{16}$ -in. shaft extending outside the unit for installation of a field-supplied damper (42VAC,VBC,VFC).
- 23. Unit shall operate on 208, 220, 240, or 277-v, single-phase, 50 or 60 Hz electrical power as

- specified on the equipment schedule. All wiring shall be in flexible conduit.
24. A stainless steel drain pan shall be available for factory installation.
  25. Factory-installed insulation options shall include foil faced fiberglass or closed cell insulation.
  26. Control Options:
    - a. Furred-in units shall be furnished with a 3-speed, 4-position manual fan switch on a wall plate for field-mounting. Cabinet units shall be furnished with a factory-installed, 3-speed, 4-position manual fan switch.
    - b. Factory-installed 24-v transformer and relay board for use, with 24-v controls by others.
- c. Carrier's Debonair® 24-v digital display programmable or non-programmable thermostat, including factory-installed 24-v transformer, relay board, and changeover sensors, as required. Provides automatic fan speed control based on demand.
  - d. Factory-Installed Carrier Fan Coil Open Controller: BACnet\* based communicating controller with pre-programmed control algorithms; including factory-installed 24-v transformer, relay board, supply air sensor, return air sensor and changeover sensor (as required). Provides automatic fan speed control based on demand.

\*BACnet is a Registered trademark of ASHRAE (American Society of Heating, Refrigerating, and Air-Conditioning Engineers).

# Index



- 42CA section 34-59
- 42CE section 34-59
- 42CG section 34-59
- 42CK section 34-59
- 42DA section 81-90
- 42DC section 81-90
- 42DD section 81-90
- 42DE section 81-90
- 42DF section 81-90
- 42SG section 91-113
- 42SH section 91-113
- 42SJ section 91-113
- 42SM section 91-113
- 42SU section 91-113
- 42VAC section 60-80
- 42VBC section 60-80
- 42VCA section 60-80
- 42VEA section 60-80
- 42VFC section 60-80
- 42VGA section 60-80
- Air delivery
  - 42C 54-57
  - 42S 105-110
- Application data 17-33
- AHRI rating data
  - 42C 35
  - 42D 81
  - 42S 92
  - 42V 61
- Arrangements, 42S 20-22
- Automatic changeover 16
- Capacities
  - 42C 35
  - 42D 81
  - 42S 92
  - 42V 61
- Certifications and listings 35, 61, 81, 92
- Coil connections 27, 76
- Controls 13-16
  - Selection guide 13
  - Remote-mounted 14
  - Unit-mounted 14, 15
- Cv factor 29
- Dimensions
  - Accessories
    - 42C 53
    - 42S 101-105
    - 42V 76-77
  - Base unit
    - 42C 37-52
    - 42D 83-87
    - 42S 93-100
    - 42V 63-75
- Discharge air grilles 53, 77
- Electric heaters 13, 31, 32, 58, 78, 88, 113
- Electrical data
  - 42C 58, 59
  - 42D 88-90
  - 42S 112, 113
  - 42V 78-80
- Features/Benefits 1-7
- Filters
  - 42C 36
  - 42D 82
  - 42S 92
  - 42V 62
- Guide specifications
  - 42C 114-116
  - 42D 117-119
  - 42S 120-122
  - 42V 123, 124
- Isolation valves 27
- Model number nomenclature
  - 42C 34
  - 42D 81
  - 42S 91
  - 42V 60
- Motor data
  - 42C 58, 59
  - 42D 88-90
  - 42S 112, 113
  - 42V 78-80
- Options 8-12
- Panel combinations 11, 102-105
- Performance data
  - 42C 54-57
  - 42S 106-111
- Physical data
  - 42C 36
  - 42D 82
  - 42S 92
  - 42V 62
- Piping 18, 23-26
- Risers 11, 19, 111
- Selection procedure 17
- Service fittings 27
- Shipping weights
  - 42C 36
  - 42D 82
  - 42S 92
  - 42V 62
- Seismic compliance compatibility 10
- Strainer 24, 27
- Thermostat 10-15
- Valve package arrangements 27
- Water flow balancing
  - Components 27

