

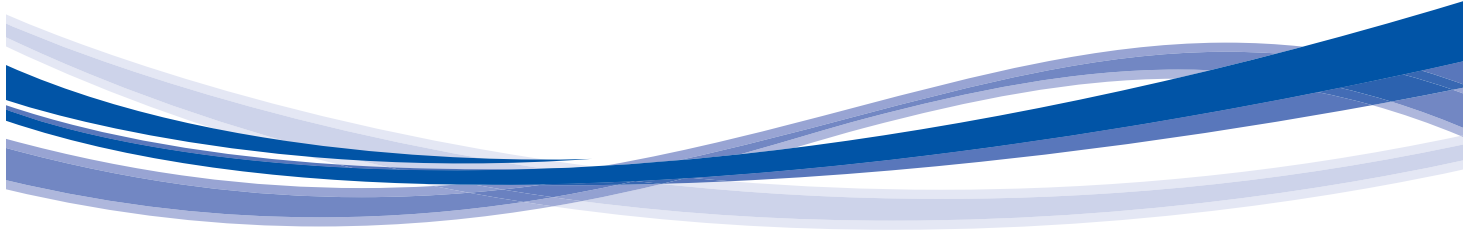

Turn to the experts

Product Data  
WeatherMaker®  
Single Packaged Rooftop  
5 Nominal Tons (18.17 kW)



ecoblue™  technology



50FC 07 Electric Cooling Rooftop Units with Optional Electric Heat  
with Puron® Refrigerant (R-410A) 50 Hz

**The New Carrier WeatherMaker® rooftop units (RTU) with EcoBlue™ Technology were designed by customers for customers and integrate new technology to provide value added benefits never seen in this type of equipment before.**

New major design features include:

- Patent pending, industry’s first efficient indoor fan system using Vane Axial fan with electric commutated variable speed motor
- Upgraded unit control board with intuitive indoor fan adjustment
- Reliable copper tube/aluminum fin condenser coil with 5/16-in. tubing to help reduce refrigerant charge versus prior designs
- New outdoor fan system with rugged — lightweight high impact composite fan blade

WeatherMaker 50FC 5 ton units are specifically designed to fit on Carrier roof curbs that were installed back to 1989, which makes replacement easy and eliminates the need for curb adapters or changing utility connections.

All models are capable of either vertical or horizontal airflow.

The Carrier rooftop unit (RTU) was designed by customers for customers.

With “no-strip” screw collars, handled access panels, and more, the unit is easy to install, easy to maintain, and easy to use. Your new 5 ton Carrier WeatherMaker rooftop unit (RTU) provides optimum comfort and control from a packaged rooftop.

Value-added features include:

- Puron® refrigerant (R-410A)
- Single point electrical connections
- RTU Open controller for BACnet<sup>1</sup>, LonWorks<sup>2</sup>, Modbus<sup>3</sup> and Johnson Controls N2
- Scroll compressors with internal line-break overload protection
- Units come with an easy access tool-less filter door. Filter track tilts out for filter removal and replacement. All filters are the same size in each unit

**Installation ease**

All WeatherMaker units are field-convertible to horizontal airflow, which makes it easy to adjust to unexpected job-site complications. Lighter units make for easy replace. Simple, fast plug-in connections to the standard

1. BACnet is a registered trademark of ASHRAE (American Society of Heating, Refrigerating and Air-Conditioning Engineers).
2. LonWorks is a registered trademark of Echelon Corporation.
3. Modbus is a registered trademark of Schneider Electric.

integrated unit control board (UCB). Clearly labeled connections points to reduce installation time. Also, a large control box provides room to work and room to mount Carrier accessory controls.

**Easy to maintain**

With the new EcoBlue Vane Axial fan system and direct drive ECM motor, there is no longer a need to adjust belts or pulleys as in past designs. This frees up maintenance and installation time.

Easy access handles by Carrier provide quick and easy access to all normally serviced components. Our “no-strip” screw system has superior holding power and guides screws into position while preventing the screw from stripping the unit’s metal.

Sloped, corrosion resistant composite drain pan sheds water; and won’t rust.

**Easy to use**

The new Unit Control Board by Carrier puts all connections and troubleshooting points in one convenient place. Most low voltage connections are made to the same board for easy access. Setting up the fan is simple with an intuitive switch and rotary dial arrangement. Carrier rooftops have high and low pressure switches, a filter drier, and 2-in. filters standard.

## Table of contents

	Page
Features/Benefits . . . . .	2
Model Number Nomenclature . . . . .	4
Capacity Ratings . . . . .	5
Physical Data . . . . .	6
Options and Accessories . . . . .	7
Base Unit Dimensions . . . . .	11
Accessory Dimensions . . . . .	14
Performance Data . . . . .	15
Fan Data . . . . .	21
Electrical Data . . . . .	26
Typical Wiring Diagrams . . . . .	29
Sequence of Operation . . . . .	31
Application Data . . . . .	33
Guide Specifications . . . . .	34

## EcoBlue™ Technology

Direct drive EcoBlue Technology indoor fan system uses Vane Axial fan design and electrically commutated motors.

This new Vane Axial design over past belt drive systems has 75% fewer moving parts, uses up to 40% less energy and has no fan belts, blower bearings and shaft.

## Streamlined control and integration

Carrier controllers make connecting WeatherMaker rooftops into existing building automation systems easy. The units are compatible with conventional thermostat controls.

## Operating efficiency and flexibility

The 50FC rooftop units meet ASHRAE (American Society of Heating, Refrigerating, and Air-Conditioning Engineers)

90.1-2016, IECC<sup>1</sup> (International Energy Conservation Code) IECC-2018 minimum efficiency requirements.

## Field convertible airflow

All WeatherMaker 5 ton units are field-convertible to horizontal airflow, which makes it easy to adjust to unexpected job-site.

1. IECC is a registered trademark of the International Code Council, Inc.

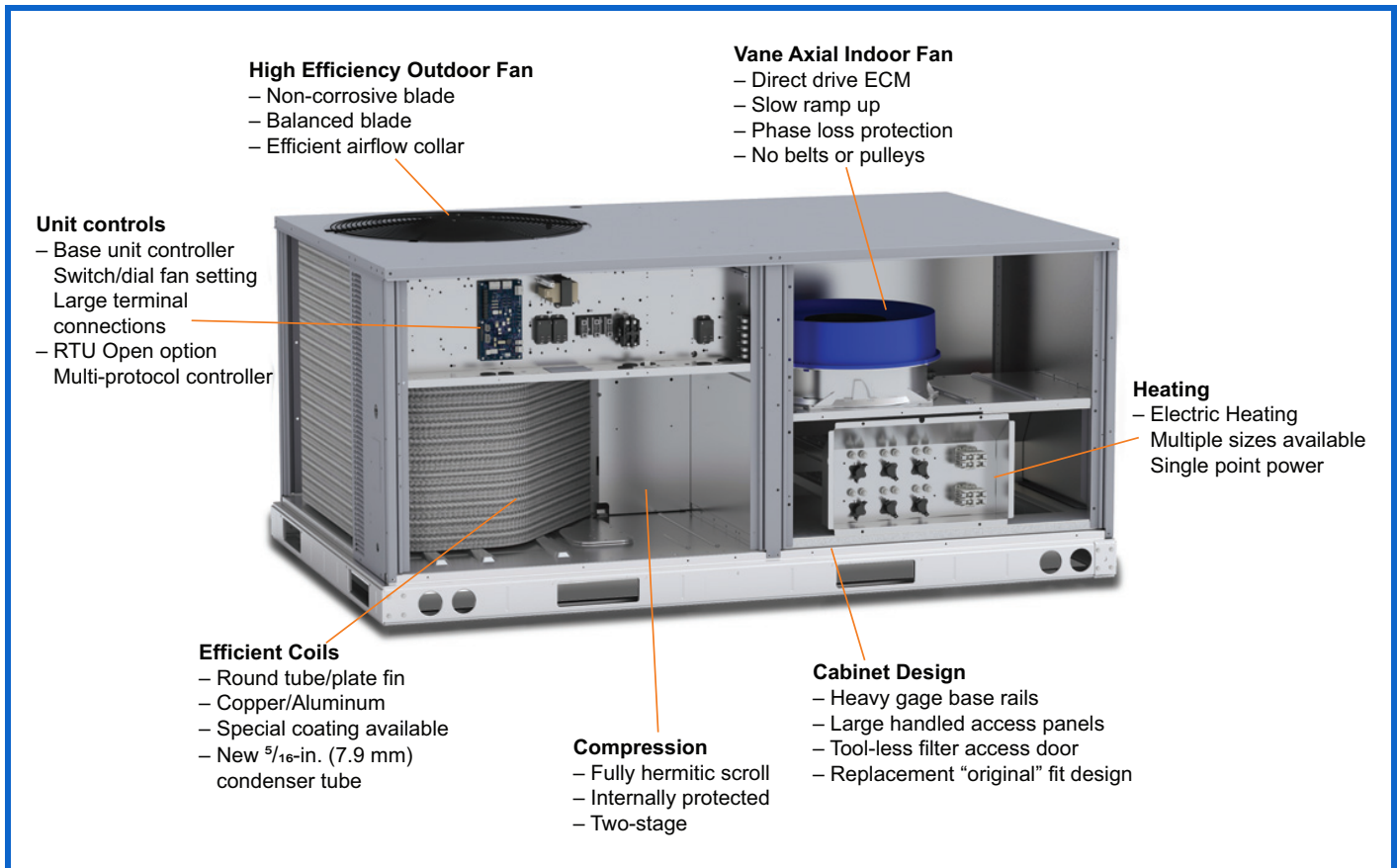

## 50FC MODEL NUMBER NOMENCLATURE

Position:	1	2	3	4	5	6	7	8	9	10	11	12	13	14	15	16	17	18
Example:	5	0	F	C	-	M	0	7	A	2	A	9	-	0	A	0	A	0

### Unit Heat Type

50 – Electric Heat Packaged Rooftop

### Model Series - WeatherMaker®

FC – 14.0 SEER Standard Efficiency

### Heat Size

- = No heat

### Refrig. Systems Options

M = Single Circuit, Two Stage Cooling

### Cooling Tons

07 = 18.17 kW (5 ton)

### Sensor Options

- A = None
- B = Return Air (RA) Smoke Detector
- C = Supply Air (SA) Smoke Detector
- D = RA + SA Smoke Detector
- E = CO<sub>2</sub> Sensor
- F = RA Smoke Detector and CO<sub>2</sub> Sensor
- G = SA Smoke Detector and CO<sub>2</sub> Sensor
- H = RA + SA Smoke Detector and CO<sub>2</sub> Sensor
- J = Condensate Overflow Switch
- K = Condensate Overflow Switch and RA Smoke Detector
- L = Condensate Overflow Switch and RA and SA Smoke Detectors
- M = Condensate Overflow Switch and SA Smoke Detector

### Indoor Fan Options

- 1 = Direct Drive – EcoBlue – Standard Static
- 2 = Direct Drive – EcoBlue – Medium Static
- 3 = Direct Drive – EcoBlue – High Static

### Coil Options (Outdoor – Indoor – Hail Guard)

- A = Al/Cu – Al/Cu
- B = Precoat Al/Cu – Al/Cu
- C = E-coat Al/Cu – Al/Cu
- D = E-coat Al/Cu – E-coat Al/Cu
- E = Cu/Cu – Al/Cu
- F = Cu/Cu – Cu/Cu
- M = Al/Cu – Al/Cu – Louvered Hail Guard
- N = Precoat Al/Cu – Al/Cu – Louvered Hail Guard
- P = E-coat Al/Cu – Al/Cu – Louvered Hail Guard
- Q = E-coat Al/Cu – E-coat Al/Cu – Louvered Hail Guard
- R = Cu/Cu – Al/Cu – Louvered Hail Guard
- S = Cu/Cu – Cu/Cu – Louvered Hail Guard

### Packaging & Seismic Compliance

0 = Standard

### Electrical Options

- A = None
- C = Non-Fused Disconnect
- D = Thru-The-Base Connections (TTB)
- F = Non-Fused Disconnect and Thru-The-Base Connections
- N = Phase Monitor/Protection
- Q = Phase Monitor/Protection and Non-Fused Disconnect
- R = Phase Monitor/Protection and TTB
- T = Phase Monitor/Protection, Non-Fused Disconnect, TTB

### Service Options

- 0 = None
- 3 = Hinged Access Panels
- 6 = MERV-8 High Efficiency Filters
- 9 = Hinged Access Panels and MERV-8 Filters

### Intake / Exhaust Options

- A = None
- B = Temperature Economizer w/ Barometric Relief
- F = Enthalpy Economizer w/ Barometric Relief
- K = Two-Position Damper
- U = Temperature Ultra Low Leak Economizer w/ Barometric Relief
- W = Enthalpy Ultra Low Leak Economizer w/ Barometric Relief

### Base Unit Controls

- 0 = Electro-mechanical Controls – can be used with field-installed W7212 EconoMiSer® IV (Non-Fault Detection and Diagnostic)
- 2 = RTU Open Multi-Protocol Controller
- 6 = Electro-mechanical Controls – can be used with W7220 EconoMiSer X (with Fault Detection and Diagnostic)

### Design Revision

- = Factory Design Revision

### Voltage

9 = 400/3/50

## 50FC AHRI RATINGS

50FC UNIT	COOLING STAGES	NOMINAL CAPACITY (TONS)	NET COOLING CAPACITY (MBH) [kW]	TOTAL POWER (kW)	SEER <sup>1</sup>	EER <sup>2</sup>	IEER <sup>2</sup> WITH 2-SPEED INDOOR FAN MOTOR
50FC*M07	2	5	59.0 [17.3]	5.0	15.0	11.8	18.8

### LEGEND

**AHRI** — Air-Conditioning, Heating and Refrigeration Institute  
**EER** — Energy Efficiency Ratio  
**IEER** — Integrated Energy Efficiency Ratio  
**SEER** — Integrated Energy Efficiency Ratio

efficiency for commercial unitary air-conditioning equipment on the basis of weighted operation at various load capacities.

- 50FC units comply with ASHRAE 90.1-2016 (American Society of Heating, Refrigerating, and Air-Conditioning Engineers) and DOE-2018 (Department of Energy) Energy Standard for minimum SEER, IEER, and EER requirements.

### NOTES:

- Units tested under AHRI 210/240 standard conditions.
- Units tested under AHRI 340/360 standard conditions.
- Test conditions are based on:  
**Cooling Standard:** 27°C (80°F) db, 19°C (67°F) wb indoor air temperature and 35°C (95°F) db outdoor air temperature.  
**IEER Standard:** A measure that expresses cooling part-load EER



## SOUND RATINGS TABLE

50FC UNIT	COOLING STAGES	OUTDOOR SOUND (dB)								
		A-WEIGHTED	63	125	250	500	1000	2000	4000	8000
50FC*M07	2	79	85.6	84.7	80.5	76.0	72.4	68.0	62.8	59.3

### LEGEND

**dB** — Decibel

### NOTES:

- Outdoor sound data is measured in accordance with AHRI Standard 270.
- Measurements are expressed in terms of sound power. Do not compare these values to sound pressure values because sound pressure depends on specific environmental factors which normally do not match individual applications. Sound power values are independent of the environment and therefore more accurate.
- A-weighted sound ratings filter out very high and very low frequencies, to better approximate the response of "average" human ear. A-weighted measurements for Carrier units are taken in accordance with AHRI Standard 270.

## MINIMUM - MAXIMUM AIRFLOW RATINGS (CFM) — COOLING UNITS AND ACCESSORY ELECTRIC HEAT

50FC UNIT	COOLING				ELECTRIC HEAT*	
	MINIMUM AIRFLOW CFM (CFM [L/s])	MINIMUM 2-SPEED AIRFLOW LOW SPEED (CFM [L/s])	MINIMUM 2-SPEED AIRFLOW HIGH SPEED (CFM [L/s])	MAXIMUM AIRFLOW CFM (CFM [L/s])	MINIMUM AIRFLOW CFM (CFM [L/s])	MAXIMUM AIRFLOW CFM (CFM [L/s])
50FC*M07	1800 [846]	1200 [564]	1800 [846]	3000 [1410]	1800 [846]	3000 [1410]

\* Electric heat modules are available as field-installed accessories for 50FC units.

## 50FC 5 TON PHYSICAL DATA

50FC UNIT	50FC*M07 (English)
<b>NOMINAL TONS</b>	5
<b>REFRIGERATION SYSTEM</b>	
No. Circuits/No. Compressors/Type	1 / 1 / 2-Stage Scroll
Puron® (R-410A) charge A/B (lbs-oz) [kg]	10-0 [4.5]
Metering device	TXV
High-Pressure Trip/Reset (psig)	630/505
Low-Pressure Trip/Reset (psig)	54/117
<b>EVAPORATOR COIL</b>	
Material (Tube/Fin)	Cu/Al
Coil Type	<sup>3</sup> / <sub>8</sub> -in. [10 mm] RTPF
Rows/FPI	4/15
Total Face Area (ft²) [m²]	7.3 [0.67]
Condensate Drain Connection Size	<sup>3</sup> / <sub>4</sub> -in. [19 mm]
<b>CONDENSER COIL</b>	
Material	Cu/Al
Coil Type	<sup>5</sup> / <sub>16</sub> -in. [7 mm] RTPF
Rows/FPI	2/18
Total Face Area (ft²) [m²]	15.0 [1.4]
<b>Standard Static 3 Phase</b>	
Motor Qty/Drive Type	1/Direct
Max Cont BHP	1.31
RPM [r/s] Range	230-2300 [3.8-38.3]
Fan Qty/Type	1/Vane Axial
Fan Diameter (in.) [mm]	16.6 [421.6]
<b>Medium Static 3 Phase</b>	
Motor Qty/Drive Type	1/Direct
Max Cont BHP	1.76
RPM Range	253-2530 [4.2-42.2]
Fan Qty/Type	1/Vane Axial
Fan Diameter (in.) [mm]	16.6 [421.6]
<b>High Static 3 Phase</b>	
Motor Qty/Drive Type	1/Direct
Max Cont BHP	2.43
RPM Range	284-2836 [4.7-47.3]
Fan Qty/Type	1/Vane Axial
Fan Diameter (in.) [mm]	16.6 [421.6]
<b>CONDENSER FAN AND MOTOR</b>	
Qty / Motor Drive Type	1 / Direct
Motor HP/RPM [Motor kW / r/s]	<sup>1</sup> / <sub>4</sub> / 1100 [0.186 / 18]
Fan Diameter (in.) [mm]	23 [584.2]
<b>FILTERS</b>	
RA Filter Qty / Size (in.)	4 / 16x16x2 [4 / 406x406x51]
OA Inlet Screen Qty / Size (in.)	1 / 20x24x1 [1 / 508x610x25]



# Options and accessories



ITEM	OPTION*	ACCESSORY†
<b>ELECTRIC HEAT</b>		
Electric resistance heaters		X
Single point kits		X
<b>CABINET</b>		
Thru-the-base electrical connections	X	X
Hinged access panels	X	
MERV-8 filters	X	
<b>COIL OPTIONS</b>		
Cu/Cu indoor and/or outdoor coils	X	
Pre-coated outdoor coils	X	
Premium, E-coated outdoor coils	X	
<b>CONDENSER PROTECTION</b>		
Condenser coil hail guard (louvered design)	X	X
<b>CONTROLS</b>		
Thermostats, temperature sensors, and subbases		X
Smoke detector (supply and/or return air)	X	
Horn strobe annunciator <sup>1</sup>		X
Time guard II compressor delay control circuit		X
Phase monitor	X	X
Condensate overflow switch	X	X

ITEM	OPTION*	ACCESSORY†
<b>ECONOMIZERS AND OUTDOOR AIR DAMPERS</b>		
EconoMi\$er® IV for electro-mechanical controls - Non FDD (Low air leak damper models) <sup>2</sup>	X	X
EconoMi\$er2 for DDC controls (Low Leak and Ultra Low Leak air damper models) <sup>3</sup>	X	X
EconoMi\$er X for electro-mechanical controls, complies with FDD (Low Leak and Ultra Low Leak damper models) <sup>2</sup>	X	X
Motorized 2-position outdoor-air damper	X	X
Manual outdoor-air damper (25% and 50%)		X
Barometric relief <sup>4</sup>	X	X
Power exhaust - prop design		X
<b>ECONOMIZER SENSORS AND IAQ DEVICES</b>		
Single dry bulb temperature sensors <sup>5</sup>	X	X
Differential dry bulb temperature sensors <sup>5</sup>		X
Single enthalpy sensors <sup>5</sup>	X	X
Differential enthalpy sensors <sup>5</sup>		X
CO <sub>2</sub> sensor (wall, duct, or unit mounted) <sup>5</sup>	X	X
<b>INDOOR MOTOR AND DRIVE</b>		
Multiple motor and drive packages	X	
<b>LOW AMBIENT CONTROL</b>		
Winter start kit <sup>6</sup>		X
Low ambient controller to -20°F (-29°C) <sup>6</sup>		X
<b>POWER OPTIONS</b>		
Non-fused disconnect <sup>7</sup>	X	
<b>ROOF CURBS</b>		
Roof curb 14-in. (356 mm)		X
Roof curb 24-in. (610 mm)		X

\* Factory-installed option

† Field-installed accessory

## NOTES:

- Requires a field-supplied 24V transformer for each application. See price pages for details.
- FDD (Fault Detection and Diagnostic) capability per California Title 24 section 120.2.
- Models RTU Open DDC controls comply with California Title 24 Fault Detection and Diagnostic (FDD).
- Included with economizer.
- Sensors used to optimize economizer performance.
- See application data for assistance.
- Non-fused disconnect switch cannot be used when unit electrical rating exceeds: 80 amps (FLA). Carrier RTUBuilder automatically selects the amp limitations.

## Factory-installed options

### Economizer (dry-bulb or enthalpy)

Economizers save money. They bring in fresh, outside air for ventilation; and provide cool, outside air to cool your building. This is the preferred method of low-ambient cooling. When coupled to CO<sub>2</sub> sensors, economizers can provide even more savings by coupling the ventilation air to only that amount required.

Economizers are available, installed and tested by the factory, with either enthalpy or dry-bulb temperature inputs. Additional sensors are available as accessories to optimize the economizers. Economizers include a powered exhaust system to help equalize building pressures.

Economizers include gravity controlled barometric relief that helps equalize building pressure and ambient air pressures. This can be a cost effective solution to prevent building pressurization. Economizers are available in ultra low leak and low leak versions. Economizers can be factory-installed or easily field-installed.

### Unit mounted CO<sub>2</sub> sensor

The CO<sub>2</sub> sensor works with the economizer to intake only the correct amount of outside air for ventilation. As occupants fill your building, the CO<sub>2</sub> sensor detects their presence through increasing CO<sub>2</sub> levels, and opens the economizer appropriately. When the occupants leave, the CO<sub>2</sub> levels decrease, and the sensor appropriately closes the economizer. This intelligent control of the ventilation air, called demand controlled ventilation (DCV), reduces the overall load on the rooftop, saving money. It is also available as a field-installed accessory.

### Smoke detector (supply and/or return air)

Trust the experts. Smoke detectors make your application safer and your job easier. Carrier smoke detectors immediately shut down the rooftop unit when smoke is detected. They are available, installed by the factory, for supply air, return air, or both.

### Thru-the-base connections

Thru-the-base connections, available as a factory option, are necessary to ensure proper connection and seal when routing wire and piping through the rooftop's basepan and curb. These couplings eliminate roof penetration and should be considered for main power lines, as well as control power.

### Hinged access panels

Allows access to unit's major components with specifically designed hinged access panels. Panels are filter, control box access indoor fan motor access.

### Cu/Cu (indoor) coils

Copper fins and copper tubes are mechanically bonded to copper tubes and copper tube sheets. A polymer strip prevents coil assembly from contacting the sheet metal coil pan to minimize potential for galvanic corrosion between coil and pan.

### E-coated (outdoor and indoor) coils

A flexible epoxy polymer coating uniformly applied to all coil surface areas without material bridging between fins. Coating process shall ensure complete coil encapsulation of tubes, fins and headers.

### Pre-coated outdoor coils

A durable epoxy-phenolic coating to provide protection in mildly corrosive coastal environments. The coating minimizes galvanic action between dissimilar metals. Coating is applied to the aluminum fin stock prior to the fin stamping process to create an inert barrier between the aluminum fin and copper tube.

### Condenser coil hail guard

Sleek, louvered panels protect the condenser coil from hail damage, foreign objects, and incidental contact.

### Single enthalpy sensor

Prevents the wheel from rotating if the outside air conditions are acceptable for free cooling. Both exhaust and supply blowers will remain on.

### Non-fused disconnect

This OSHA-compliant, factory-installed, safety switch allows a service technician to locally secure power to the rooftop. When selecting a factory-installed non-fused disconnect, note they are sized for the unit as ordered from the factory. The sizing of these do not accommodate field-installed items such as power exhaust devices, etc. If field installing electric heat with factory-installed non-fused disconnect switch, a single point kit may or may not be required.

### MERV-8 return air filters

This factory option upgrades the return air filters from standard unit filters to high efficiency MERV-8 filters. Non-woven MERV-8 filter media with high strength, moisture-resistant frame. Filter media is securely fastened inside the filter frame on all four sides.



## Field-installed accessories

### Filter maintenance indicator

When the optional factory-installed filter maintenance indicator is used, a factory-installed differential pressure switch measures pressure drop across the outside air filter and activates a field-supplied dry contact indicator when the pressure differential exceeds the adjustable switch setpoint.

### Condenser coil hail guard

Sleek, louvered panels protect the condenser coil from hail damage, foreign objects, and incidental contact. This can be purchased as a factory-installed option or as a field-installed accessory.

### Differential enthalpy sensor

The differential enthalpy sensor is comprised of an outdoor and return air enthalpy sensors to provide differential enthalpy control. The sensor allows the unit to determine if outside air is suitable for free cooling.

### Wall or duct mounted CO<sub>2</sub> sensor

The IAQ sensor shall be available in duct or wall mount. The sensor provides demand ventilation indoor air quality (IAQ) control.

### Phase monitor protection

The Phase Monitor Control will monitor the sequence of three phase electrical system to provide a phase reversal protection; and monitor the three phase voltage inputs to provide a phase loss protection for the three phase device. It will work on either a Delta or Wye power connection.

### Winter start kit

The winter start kit by Carrier extends the low ambient limit of your rooftop to 25°F (-4°C). The kit bypasses the low pressure switch, preventing nuisance tripping of the low pressure switch. Other low ambient precautions may still be prudent.

### Low ambient controller

The low ambient controller is a head pressure controller kit that is designed to maintain the unit's condenser head pressure during periods of low ambient cooling operation. This device should be used as an alternative to economizer free cooling when economizer usage is either not appropriate or desired. The low ambient controller will either cycle the outdoor fan motors or operate them at reduced speed to maintain the unit operation, depending

on the model. This controller allows cooling operation down to -20°F (-29°C) ambient conditions.

### Roof curb 14-in. (356 mm) or 24-in. (610 mm)

Full perimeter roof curb with exhaust capability provides separate air streams for energy recovery from the exhaust air without supply air contamination.

### Filter status indicator accessory

Monitors static pressure across supply and exhaust filters and provides indication when filters become clogged.

### Power exhaust

Superior internal building pressure control. This field-installed accessory may eliminate the need for costly, external pressure control fans.

### Manual OA Damper

Manual outdoor air dampers are an economical way to bring in ventilation air. The dampers are available in 25% and 50% versions.

NOTE: See application tip "ROOFTOP-18-01" prior to use of this damper on 07 size models.

### Motorized 2-Position Damper

The Carrier 2-position, motorized outdoor air damper admits up to 100% outside air. Using reliable, gear-driven technology, the 2-position damper opens to allow ventilation air and closes when the rooftop stops, stopping unwanted infiltration.

NOTE: See application tip "ROOFTOP-18-01" prior to use of this damper on 07 size models.

### Electric Heaters

Carrier offers a full-line of field-installed accessory heaters. The heaters are very easy to use, install and are all pre-engineered and certified.

### Time Guard II control circuit

This accessory protects your compressor by preventing short-cycling in the event of some other failure, prevents the compressor from restarting for 30 seconds after stopping. Not required with RTU Open controller, or authorized commercial thermostats.

### Power exhaust with barometric relief

Superior internal building pressure control. This field-installed accessory may eliminate the need for costly, external pressure control fans.

# Options and accessories (cont)



## OPTIONS AND ACCESSORY WEIGHTS

OPTION / ACCESSORY NAME	50FC UNIT WEIGHT	
	07	
	lb	kg
Power Exhaust - Vertical	51	23
Power Exhaust - Horizontal	39	18
EconoMi\$er® (X, IV or 2)	35	16
2-Position Damper	58	26
Manual Damper	18	8
Hail Guard (louvered)	17	8
Cu/Cu Condenser Coil	95	43
Cu/Cu Condenser and Evaporator Coils	165	75
Roof Curb (14-in. curb)	95	43
Roof Curb (24-in. curb)	150	68
CO <sub>2</sub> Sensor	2	1
Optional Indoor Motor/Drive	15	7
Low Ambient Controller	9	4
Winter Start Kit	5	2
Return Air Smoke Detector	7	3
Supply Air Smoke Detector	7	3
Fan Filter Switch	2	1
Non-Fused Disconnect	15	7
Enthalpy Sensor	2	1
Differential Enthalpy Sensor	3	1

NOTE: Where multiple variations are available, the heaviest combination is listed.

## 50FC\*\*07 BASE UNIT DIMENSIONS

**NOTES:**

- DIMENSIONS ARE IN INCHES. DIMENSIONS IN [ ] ARE IN MILLIMETERS.
- CENTER OF GRAVITY
- DIRECTION OF AIR FLOW
- ALL VIEW DRAWN USING 3RD ANGLE

THIS DOCUMENT IS THE PROPERTY OF ITC CLIMATE CONTROLS & SECURITY AND IS DELIVERED UNDER THE EXPRESS CONDITION THAT IT IS TO BE USED ONLY FOR THE PROJECT AND NOT BE REPRODUCED OR COPIED IN ANY MANNER WITHOUT WRITTEN CONSENT.

Carrier  
Climate Control Technologies

UNIT	J	K
50FC**07	41'-3/8" (11931)	18'-5/8" (4472)

CONNECTION SIZES	
A	1 3/8" (33) DIA. FIELD POWER SUPPLY HOLE
B	2" (51) DIA. POWER SUPPLY KNOCKOUT
C	1 3/4" (44) DIA. GAUGE ACCESS PLUG
D	7/8" (22) DIA. FIELD CONTROL WIRING HOLE
E	3/4" x 1/4 NPT CONDENSATE DRAIN
G	2 1/2" (64) DIA. POWER SUPPLY KNOCK-OUT

THRU-THE-BASE CHART USE THESE DIMENSIONS FOR ALL WIRE SIZES UNLESS OTHERWISE SPECIFIED		
W	WIRE COND. SIZE	REC'D HOLE SIZE (MAX.)
X	1/2"	1 1/2" (38)
Y	3/4"	1 7/8" (48)
Z	1 1/2"	2 1/8" (54)

FOR "THRU-THE-BASEPAN" FACTORY OPTION, FITTINGS FOR ONLY X, Y, & Z ARE PROVIDED FOR POWER, DEPENDING ON WIRE SIZE. SELECT EITHER 3/4" OR 1 1/2" FOR POWER, DEPENDING ON WIRE SIZE. (008A00) PROVIDES 3/4" FPT THRU CURB FLANGE & FITTING.

**TOP**

**FRONT**

**LEFT**

**RIGHT**

ITC CLASSIFICATION	SHEET	DATE	SUPERCEDES	50FC	04-07 SINGLE PACKAGE ELECTRICAL COOLING WITH ELECTRIC HEAT	48TC003094
U.S. - ECCN:MSR	1 OF 3	04/02/19	10/25/18			

# Base unit dimensions (cont)



## 50FC\*\*07 BASE UNIT DIMENSIONS (cont)

THIS DOCUMENT IS THE PROPERTY OF ITC CLIMATE CONTROLS & SECURITY AND IS DELIVERED UNDER THE EXPRESS CONDITION THAT IT IS NOT TO BE REPRODUCED, COPIED, OR TRANSMITTED IN ANY FORM OR BY ANY MEANS, WITHOUT WRITTEN CONSENT.

UNIT	CORNER WEIGHT*		CORNER WEIGHT (A)		CORNER WEIGHT (B)		CORNER WEIGHT (C)		CORNER WEIGHT (D)		C.G.		HEIGHT					
	LBS.	KG.	LBS.	KG.	LBS.	KG.	LBS.	KG.	LBS.	KG.	X	Y	Z	Z				
50FC**07	562	255	154	70	137	62	127	58	143	65	35	1889	22	172	1572	19	172	1495

\* STANDARD UNIT WEIGHT IS WITHOUT ELECTRIC HEAT AND WITHOUT PACKAGING. FOR OTHER OPTIONS AND ACCESSORIES, REFER TO THE PRODUCT DATA CATALOG.

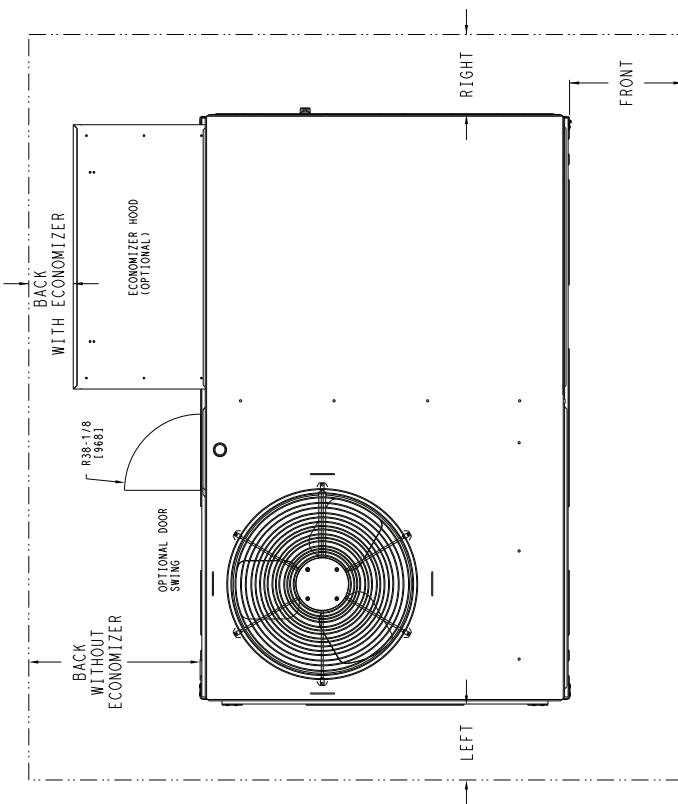

NOTE: 1. FOR ALL MINIMUM CLEARANCES LOCAL CODES OR JURISDICTIONS MAY PREVAIL.

SURFACE	CLEARANCE		OPERATING CLEARANCE	
	SERVICE WITH CONDUCTIVE BARRIER	SERVICE WITH NONCONDUCTIVE BARRIER	SERVICE WITH CONDUCTIVE BARRIER	SERVICE WITH NONCONDUCTIVE BARRIER
FRONT	48 [1219mm]	36 [914mm]	18 [457mm]	18 [457mm]
LEFT	48 [1219mm]	42 [1067mm]	18 [457mm]	18 [457mm]
BACK W/O HOOD	48 [1219mm]	42 [1067mm]	18 [457mm]	18 [457mm]
BACK W/ HOOD	36 [914mm]	36 [914mm]	18 [457mm]	18 [457mm]
RIGHT	36 [914mm]	36 [914mm]	18 [457mm]	18 [457mm]
TOP	72 [1829mm]	72 [1829mm]	72 [1829mm]	72 [1829mm]

ITC CLASSIFICATION	SHEET	DATE	DESCRIPTION
U.S. - ECCN:MSR	2 OF 3	04/02/19	50FC 04-07 SINGLE PACKAGE ELECTRICAL COOLING WITH ELECTRIC HEAT

48TC003094

# 50FC\*\*07 BASE UNIT DIMENSIONS (cont)

THIS DOCUMENT IS THE PROPERTY OF UTC CLIMATE CONTROLS. REPRODUCTION OR TRANSMISSION OF THESE PARTS OR DRAWINGS WITHOUT WRITTEN CONSENT IS PROHIBITED. THIS DOCUMENT IS NOT TO BE DISCLOSED OR USED FOR ANY OTHER PROJECT WITHOUT WRITTEN CONSENT. THIS DOCUMENT DOES NOT CONSTITUTE PART PERFORMANCE OR WARRANTY. THE USER SHALL BE RESPONSIBLE FOR THE PROPER SELECTION, INSTALLATION, MAINTENANCE, AND OPERATION OF THE EQUIPMENT. THE USER SHALL BE RESPONSIBLE FOR THE PROPER SELECTION, INSTALLATION, MAINTENANCE, AND OPERATION OF THE EQUIPMENT.

71-1/8 [1805]  
(INSIDE THE BASE RAIL & SKIRT)

41-1/4 [1047]  
(INSIDE THE BASERAILS)

INSIDE BASERAIL DIMENSIONS  
BOTTOM

DETAIL C  
TYP 4 PLCS

Dimensions: 2X 1-7/8 [48], 2X 1-3/4 [46], 2X 1 [25], 2X 1-3/8 [36], 2X 3/4 [18], 3-1/4 [82], 3-7/8 [99]

BACK

LEFT

FRONT

Dimensions: 2X 1-7/8 [47.6], 3-1/4 [82.0], 59-3/8 [1509.0], 7-1/8 [180.7], 2-3/8 [60.3] CURB WIDTH

SEE DETAIL C

ITC CLASSIFICATION U.S. - ECCN: NSR	SHEET 3 OF 3	DATE 04/02/19	SUPERSEDES 10/25/18	50FC 04-07 SINGLE PACKAGE ELECTRICAL COOLING WITH ELECTRIC HEAT	48TC03094	REV C
--	-----------------	------------------	------------------------	---	-----------	----------

## ROOF CURB DIMENSIONS — 50FC 07

CONNECTOR PKG. ACC.	GAS CONNECTION TYPE	GAS FITTING	POWER WIRING FITTINGS	CONTROL WIRING FITTING	ACCESSORY CONVENIENCE OUTLET WIRING CONNECTOR
CRBTMPWR001A01	THRU THE CURB	3/4" [19] NPT	3/4" [19] NPT	1/2" [12.7] NPT	
CRBTMPWR003A01	THRU THE BOTTOM	1/2" [12.7] NPT			1/2" [12.7] NPT

- NOTES:  
 1. ROOF CURB ACCESSORY IS SHIPPED DISASSEMBLED.  
 2. INSULATED PANELS: 25.4 [1] THK. POLYURETHANE FOAM, 44.5 [1.34] # DENSITY.  
 3. DIMENSIONS IN [ ] ARE IN MILLIMETERS.  
 4. ROOF CURB: 18 GAGE STEEL.  
 5. EACH DUCT W/ GASKET CURB: FLANGES OF DUCT REST ON CURB.  
 6. SURFACE FINISH: 16 GA. GALV. STEEL.  
 7. DIRECTION OF AIR FLOW.  
 8. CONNECTOR PACKAGE CRBTMPWR001A01 IS FOR THRU-THE-CURB GAS TYPE PACKAGE CRBTMPWR003A01 IS FOR THRU-THE-BOTTOM TYPE GAS CONNECTIONS.

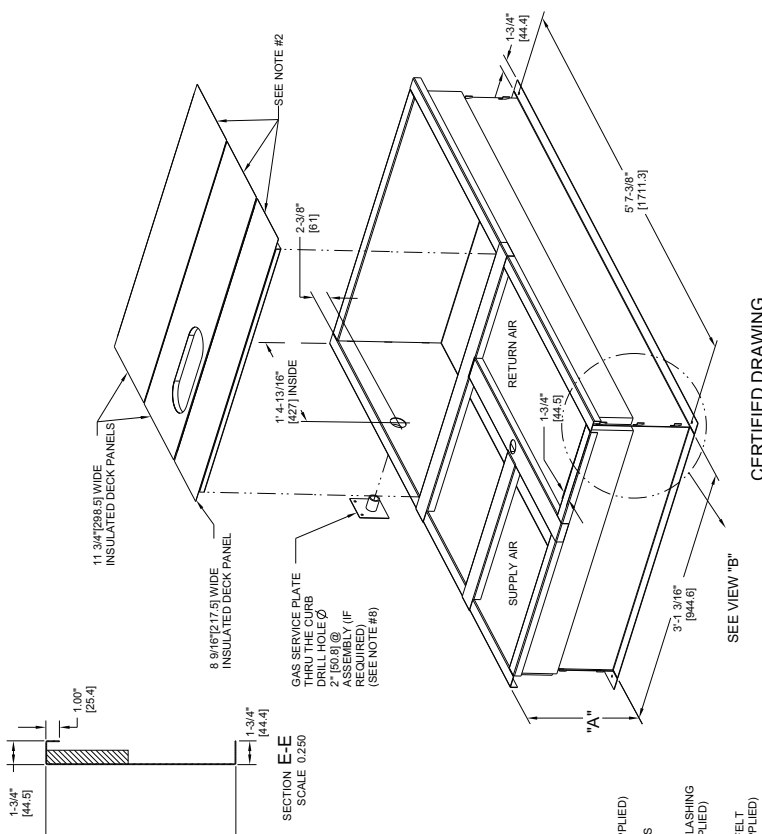

DRAWING RELEASE LEVEL:		PRODUCTION		TITLE	
THIRD ANGLE PROJECTION	UNLESS OTHERWISE SPECIFIED DIMENSIONS ARE IN INCHES	ENGINEERING	MANUFACTURING	SIZE	DRAWING NUMBER
MATERIAL	TOLERANCES ON DEC DEC ANG DEC ANG	1041738		D	48TC400427
ENGINEERING REQUIREMENTS	WEIGHT	DRUGHTER	CHECKER	TEXT DRAWING	SHEETS OF 5
T-005, T-002		MMC	061711		B
SURFACE FINISH	MEASURED PURCH	MODEL (INTERNAL USE ONLY)		SCALE	DISTRIBUTION
				N/A	MMC

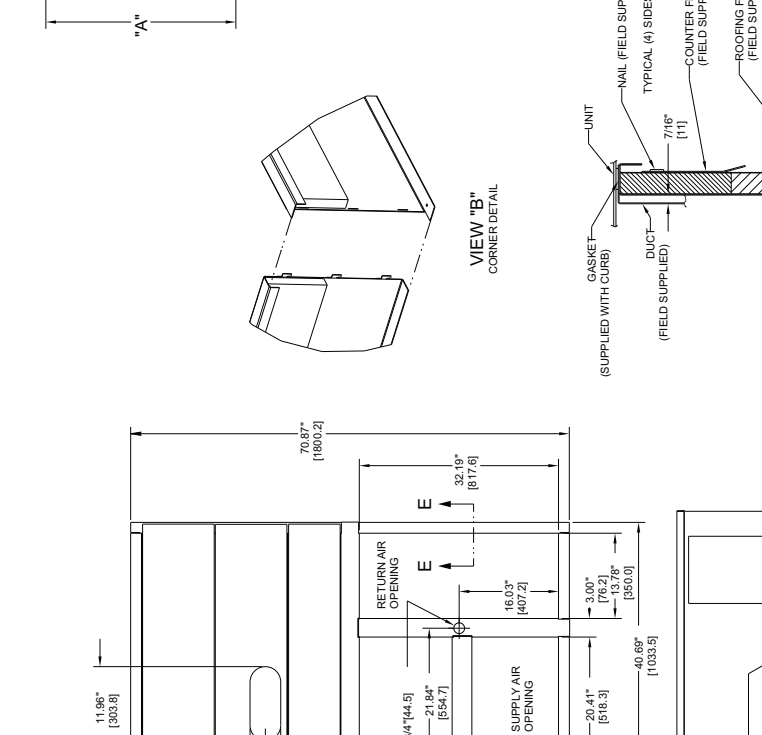

REV	DATE	BY	CHKD	APPD	ECN NO.	REVISION RECORD
A	04/22/13	MMC			1087898	OVERALL DIM. 5:7.38" WAS 5:7.78; 16GA W/ 16 GA. GALV. STEEL W/ CURB WITH CURB

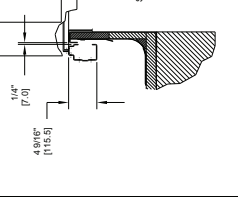
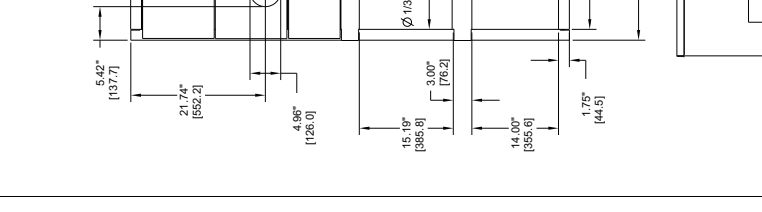











**PRESSURE DROP FOR ELECTRIC HEAT 5 TON UNITS - 1 AND 2 STAGE HEAT**

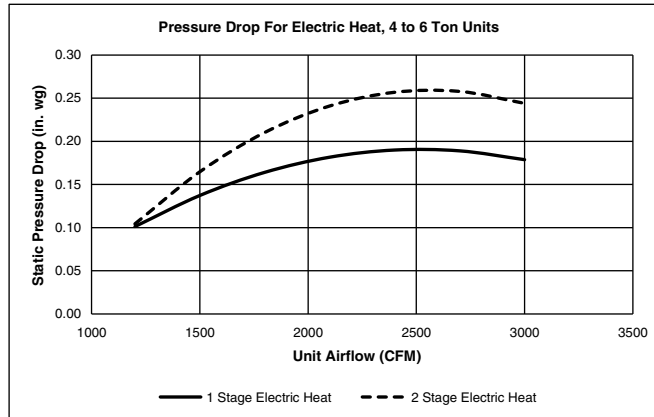

**FIELD-INSTALLED ACCESSORY ELECTRIC HEATER DATA**

50FC UNIT SIZE	VOLTAGE	HEATER MODEL NUMBER*	NUMBER OF STAGES
07	400	CRHEATER333A00	1
		CRHEATER335A00	1
		CRHEATER336A00	1
		CRHEATER337A00	2
		CRHEATER338A00	2

\*Check heater nameplate for model number.

## ECONOMIZER BAROMETRIC RELIEF AND STATIC PRESSURE

### HORIZONTAL ECONOMIZER BAROMETRIC RELIEF

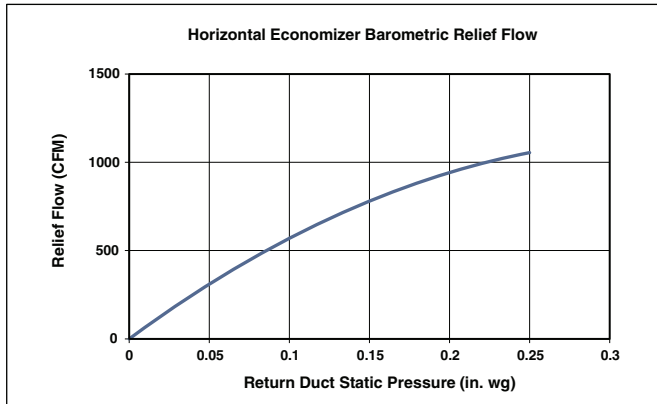

### VERTICAL ECONOMIZER BAROMETRIC RELIEF

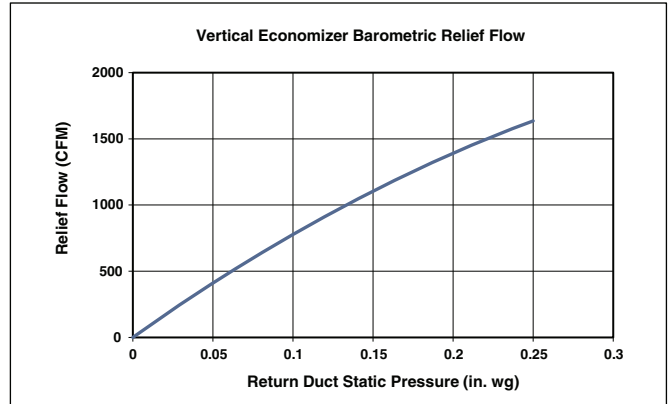

### HORIZONTAL ECONOMIZER DAMPER LEAKAGE

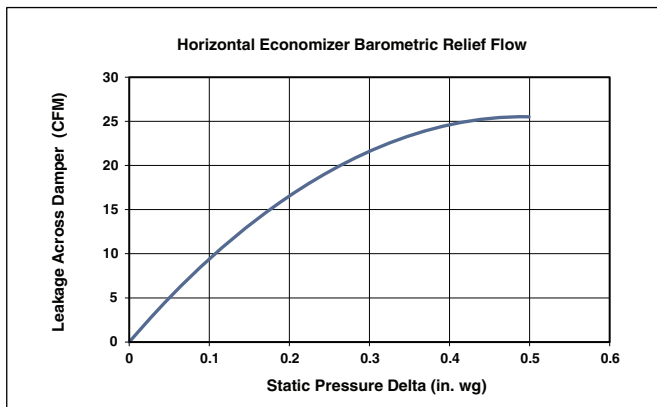

### VERTICAL ECONOMIZER DAMPER LEAKAGE

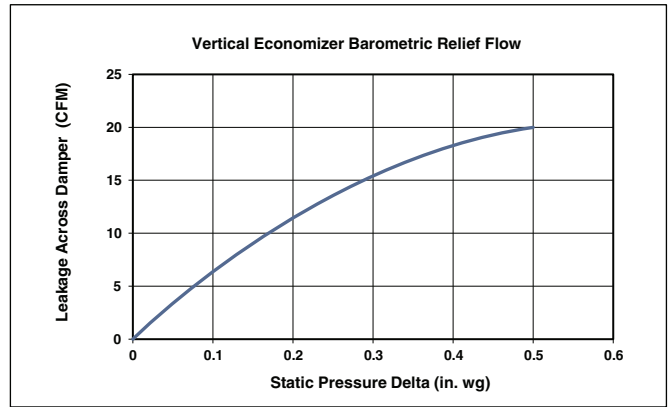

### MERV-8 filters pressure drop

NOTE: For factory-installed MERV-8 filters, no additional pressure drop adjustments are necessary. The standard fan tables accommodate usage.



## GENERAL FAN PERFORMANCE NOTES

1. Interpolation is permissible. Do not extrapolate.
2. External static pressure is the static pressure difference between the return duct and the supply duct plus the static pressure caused by any FIOPs or accessories.
3. Tabular data accounts for pressure loss due to clean filters, unit casing, and wet coils.
4. Factory options and accessories may effect static pressure losses. Unit fan tables assume no electric heat or any other factory-installed option or field-installed accessory. Selection software is available, through your salesperson, to help you select the best motor/drive combination for your application.
5. The fan performance tables offer motor/drive recommendations. In cases when two motor/drive combinations would work, Carrier recommends the lower horsepower option.
6. For information on the electrical properties of Carrier motors, please see the Electrical information section of this book.
7. For more information on the performance limits of Carrier motors, see the application data section of this book.

## 50FC-M07 THREE PHASE — 5 TON VERTICAL SUPPLY (RPM - BHP)

L/s	CFM	AVAILABLE EXTERNAL STATIC PRESSURE (in. wg) [kPa]									
		0.2 [50]		0.4 [100]		0.6 [150]		0.8 [200]		1.0 [250]	
		RPM	BHP	RPM	BHP	RPM	BHP	RPM	BHP	RPM	BHP
756	1500	1228	0.20	1394	0.29	1554	0.40	1701	0.53	1835	0.66
851	1625	1305	0.24	1457	0.33	1609	0.44	1750	0.57	1881	0.71
957	1750	1385	0.28	1523	0.37	1666	0.49	1802	0.62	1930	0.76
1076	1875	1466	0.33	1592	0.43	1726	0.54	1857	0.67	1981	0.82
1211	2000	1549	0.39	1664	0.48	1789	0.60	1914	0.74	2034	0.88
1362	2125	1633	0.46	1739	0.55	1855	0.67	1974	0.81	2089	0.95
1533	2250	1718	0.53	1816	0.63	1924	0.74	2036	0.88	2146	1.03
1724	2375	1803	0.61	1894	0.71	1995	0.83	2100	0.97	2206	1.12
1940	2500	1890	0.70	1974	0.80	2068	0.92	2167	1.06	2268	1.21

L/s	CFM	AVAILABLE EXTERNAL STATIC PRESSURE (in. wg) [kPa]									
		1.2 [300]		1.4 [350]		1.6 [400]		1.8 [450]		2.0 [500]	
		RPM	BHP	RPM	BHP	RPM	BHP	RPM	BHP	RPM	BHP
756	1500	1961	0.80	2079	0.96	2191	1.12	2297	1.29	2399	1.47
851	1625	2004	0.85	2120	1.01	2230	1.18	2334	1.35	2434	1.53
957	1750	2050	0.91	2163	1.07	2270	1.24	2373	1.41	2472	1.60
1076	1875	2098	0.97	2208	1.13	2314	1.31	2414	1.48	2511	1.67
1211	2000	2148	1.04	2256	1.21	2359	1.38	2458	1.56	2553	1.75
1362	2125	2200	1.11	2305	1.28	2407	1.46	2504	1.64	2597	1.83
1533	2250	2254	1.20	2357	1.37	2456	1.55	2551	1.73	2643	1.93
1724	2375	2310	1.28	2410	1.46	2507	1.64	2600	1.83	2690	2.03
1940	2500	2368	1.38	2465	1.56	2560	1.75	2651	1.94	2739	2.14

Standard Static 1228-2300 RPM, 1.31 Max BHP

Medium Static 1228-2530 RPM, 1.76 Max BHP

High Static 1228-2836 RPM, 2.43 Max BHP

## 50FC-M07 THREE PHASE - STANDARD STATIC — 5 TON VERTICAL SUPPLY (RPM - VDC)

L/s	CFM	AVAILABLE EXTERNAL STATIC PRESSURE (in. wg) [kPa]									
		0.2 [50]		0.4 [100]		0.6 [150]		0.8 [200]		1.0 [250]	
		RPM	Vdc	RPM	Vdc	RPM	Vdc	RPM	Vdc	RPM	Vdc
756	1500	1228	5.3	1394	6.1	1554	6.8	1701	7.4	1835	8.0
851	1625	1305	5.7	1457	6.3	1609	7.0	1750	7.6	1881	8.2
957	1750	1385	6.0	1523	6.6	1666	7.2	1802	7.8	1930	8.4
1076	1875	1466	6.4	1592	6.9	1726	7.5	1857	8.1	1981	8.6
1211	2000	1549	6.7	1664	7.2	1789	7.8	1914	8.3	2034	8.8
1362	2125	1633	7.1	1739	7.6	1855	8.1	1974	8.6	2089	9.1
1533	2250	1718	7.5	1816	7.9	1924	8.4	2036	8.9	2146	9.3
1724	2375	1803	7.8	1894	8.2	1995	8.7	2100	9.1	2206	9.6
1940	2500	1890	8.2	1974	8.6	2068	9.0	2167	9.4	2268	9.9

L/s	CFM	AVAILABLE EXTERNAL STATIC PRESSURE (in. wg) [kPa]									
		1.2 [300]		1.4 [350]		1.6 [400]		1.8 [450]		2.0 [500]	
		RPM	Vdc	RPM	Vdc	RPM	Vdc	RPM	Vdc	RPM	Vdc
756	1500	1961	8.5	2079	9.0	2191	9.5	2297	10.0	—	—
851	1625	2004	8.7	2120	9.2	2230	9.7	—	—	—	—
957	1750	2050	8.9	2163	9.4	2270	9.9	—	—	—	—
1076	1875	2098	9.1	2208	9.6	—	—	—	—	—	—
1211	2000	2148	9.3	2256	9.8	—	—	—	—	—	—
1362	2125	2200	9.6	—	—	—	—	—	—	—	—
1533	2250	2254	9.8	—	—	—	—	—	—	—	—
1724	2375	—	—	—	—	—	—	—	—	—	—
1940	2500	—	—	—	—	—	—	—	—	—	—

Standard Static 1228-2300 RPM

### 50FC-M07 THREE PHASE - MEDIUM STATIC — 5 TON VERTICAL SUPPLY (RPM - VDC)

L/s	CFM	AVAILABLE EXTERNAL STATIC PRESSURE (in. wg) [kPa]									
		0.2 [50]		0.4 [100]		0.6 [150]		0.8 [200]		1.0 [250]	
		RPM	Vdc	RPM	Vdc	RPM	Vdc	RPM	Vdc	RPM	Vdc
756	1500	1228	4.9	1394	5.5	1554	6.1	1701	6.7	1835	7.3
851	1625	1305	5.2	1457	5.8	1609	6.4	1750	6.9	1881	7.4
957	1750	1385	5.5	1523	6.0	1666	6.6	1802	7.1	1930	7.6
1076	1875	1466	5.8	1592	6.3	1726	6.8	1857	7.3	1981	7.8
1211	2000	1549	6.1	1664	6.6	1789	7.1	1914	7.6	2034	8.0
1362	2125	1633	6.5	1739	6.9	1855	7.3	1974	7.8	2089	8.3
1533	2250	1718	6.8	1816	7.2	1924	7.6	2036	8.0	2146	8.5
1724	2375	1803	7.1	1894	7.5	1995	7.9	2100	8.3	2206	8.7
1940	2500	1890	7.5	1974	7.8	2068	8.2	2167	8.6	2268	9.0

L/s	CFM	AVAILABLE EXTERNAL STATIC PRESSURE (in. wg) [kPa]									
		1.2 [300]		1.4 [350]		1.6 [400]		1.8 [450]		2.0 [500]	
		RPM	Vdc	RPM	Vdc	RPM	Vdc	RPM	Vdc	RPM	Vdc
756	1500	1961	7.8	2079	8.2	2191	8.7	2297	9.1	2399	9.5
851	1625	2004	7.9	2120	8.4	2230	8.8	2334	9.2	2434	9.6
957	1750	2050	8.1	2163	8.5	2270	9.0	2373	9.4	2472	9.8
1076	1875	2098	8.3	2208	8.7	2314	9.1	2414	9.5	2511	9.9
1211	2000	2148	8.5	2256	8.9	2359	9.3	2458	9.7	—	—
1362	2125	2200	8.7	2305	9.1	2407	9.5	2504	9.9	—	—
1533	2250	2254	8.9	2357	9.3	2456	9.7	—	—	—	—
1724	2375	2310	9.1	2410	9.5	2507	9.9	—	—	—	—
1940	2500	2368	9.4	2465	9.7	—	—	—	—	—	—

Medium Static 1228-2530 RPM

### 50FC-M07 THREE PHASE - HIGH STATIC — 5 TON VERTICAL SUPPLY (RPM - VDC)

L/s	CFM	AVAILABLE EXTERNAL STATIC PRESSURE (in. wg) [kPa]									
		0.2 [50]		0.4 [100]		0.6 [150]		0.8 [200]		1.0 [250]	
		RPM	Vdc	RPM	Vdc	RPM	Vdc	RPM	Vdc	RPM	Vdc
756	1500	1228	4.3	1394	4.9	1554	5.5	1701	6.0	1835	6.5
851	1625	1305	4.6	1457	5.1	1609	5.7	1750	6.2	1881	6.6
957	1750	1385	4.9	1523	5.4	1666	5.9	1802	6.4	1930	6.8
1076	1875	1466	5.2	1592	5.6	1726	6.1	1857	6.5	1981	7.0
1211	2000	1549	5.5	1664	5.9	1789	6.3	1914	6.7	2034	7.2
1362	2125	1633	5.8	1739	6.1	1855	6.5	1974	7.0	2089	7.4
1533	2250	1718	6.1	1816	6.4	1924	6.8	2036	7.2	2146	7.6
1724	2375	1803	6.4	1894	6.7	1995	7.0	2100	7.4	2206	7.8
1940	2500	1890	6.7	1974	7.0	2068	7.3	2167	7.6	2268	8.0

L/s	CFM	AVAILABLE EXTERNAL STATIC PRESSURE (in. wg) [kPa]									
		1.2 [300]		1.4 [350]		1.6 [400]		1.8 [450]		2.0 [500]	
		RPM	Vdc	RPM	Vdc	RPM	Vdc	RPM	Vdc	RPM	Vdc
756	1500	1961	6.9	2079	7.3	2191	7.7	2297	8.1	2399	8.5
851	1625	2004	7.1	2120	7.5	2230	7.9	2334	8.2	2434	8.6
957	1750	2050	7.2	2163	7.6	2270	8.0	2373	8.4	2472	8.7
1076	1875	2098	7.4	2208	7.8	2314	8.2	2414	8.5	2511	8.9
1211	2000	2148	7.6	2256	8.0	2359	8.3	2458	8.7	2553	9.0
1362	2125	2200	7.8	2305	8.1	2407	8.5	2504	8.8	2597	9.2
1533	2250	2254	7.9	2357	8.3	2456	8.7	2551	9.0	2643	9.3
1724	2375	2310	8.1	2410	8.5	2507	8.8	2600	9.2	2690	9.5
1940	2500	2368	8.3	2465	8.7	2560	9.0	2651	9.3	2739	9.7

High Static 1228-2836 RPM

## 50FC-M07 THREE PHASE — 5 TON HORIZONTAL SUPPLY (RPM - BHP)

L/s	CFM	AVAILABLE EXTERNAL STATIC PRESSURE (in. wg) [kPa]									
		0.2 [50]		0.4 [100]		0.6 [150]		0.8 [200]		1.0 [250]	
		RPM	BHP	RPM	BHP	RPM	BHP	RPM	BHP	RPM	BHP
756	1500	1197	0.18	1361	0.26	1524	0.36	1679	0.49	1822	0.62
851	1625	1271	0.21	1421	0.29	1574	0.40	1721	0.52	1860	0.66
957	1750	1347	0.25	1485	0.33	1627	0.44	1767	0.56	1901	0.70
1076	1875	1425	0.29	1553	0.38	1684	0.49	1816	0.61	1945	0.75
1211	2000	1504	0.35	1622	0.43	1745	0.54	1870	0.66	1992	0.80
1362	2125	1584	0.40	1695	0.49	1809	0.60	1926	0.72	2043	0.86
1533	2250	1665	0.47	1769	0.56	1876	0.67	1986	0.79	2096	0.93
1724	2375	1747	0.54	1844	0.63	1945	0.74	2049	0.87	2153	1.01
1940	2500	1830	0.62	1921	0.71	2016	0.82	2114	0.95	2213	1.09

L/s	CFM	AVAILABLE EXTERNAL STATIC PRESSURE (in. wg) [kPa]									
		1.2 [300]		1.4 [350]		1.6 [400]		1.8 [450]		2.0 [500]	
		RPM	BHP	RPM	BHP	RPM	BHP	RPM	BHP	RPM	BHP
756	1500	1954	0.77	2078	0.92	2194	1.09	2304	1.26	2408	1.44
851	1625	1990	0.81	2112	0.97	2227	1.13	2336	1.31	2439	1.49
957	1750	2028	0.85	2148	1.01	2262	1.18	2370	1.36	2472	1.54
1076	1875	2069	0.90	2186	1.06	2298	1.23	2404	1.41	2506	1.60
1211	2000	2111	0.95	2226	1.12	2335	1.29	2441	1.48	2541	1.66
1362	2125	2157	1.02	2268	1.18	2375	1.36	2478	1.54	2578	1.73
1533	2250	2206	1.08	2313	1.25	2417	1.43	2518	1.61	2616	1.81
1724	2375	2258	1.16	2361	1.33	2462	1.50	2560	1.69	2655	1.89
1940	2500	2312	1.24	2411	1.41	2509	1.59	2604	1.78	2697	1.97

Standard Static 1179-2300 RPM, 1.31 Max BHP

Medium Static 1179-2530 RPM, 1.76 Max BHP

High Static 1179-2836 RPM, 2.43 Max BHP

## 50FC-M07 THREE PHASE - STANDARD STATIC — 5 TON HORIZONTAL SUPPLY (RPM - Vdc)

L/s	CFM	AVAILABLE EXTERNAL STATIC PRESSURE (in. wg) [kPa]									
		0.2 [50]		0.4 [100]		0.6 [150]		0.8 [200]		1.0 [250]	
		RPM	Vdc	RPM	Vdc	RPM	Vdc	RPM	Vdc	RPM	Vdc
756	1800	1197	5.2	1361	5.9	1524	6.6	1679	7.3	1822	7.9
851	1950	1271	5.5	1421	6.2	1574	6.8	1721	7.5	1860	8.1
957	2100	1347	5.9	1485	6.5	1627	7.1	1767	7.7	1901	8.3
1076	2250	1425	6.2	1553	6.8	1684	7.3	1816	7.9	1945	8.5
1211	2400	1504	6.5	1622	7.1	1745	7.6	1870	8.1	1992	8.7
1362	2550	1584	6.9	1695	7.4	1809	7.9	1926	8.4	2043	8.9
1533	2700	1665	7.2	1769	7.7	1876	8.2	1986	8.6	2096	9.1
1724	2850	1747	7.6	1844	8.0	1945	8.5	2049	8.9	2153	9.4
1940	3000	1830	8.0	1921	8.4	2016	8.8	2114	9.2	2213	9.6

L/s	CFM	AVAILABLE EXTERNAL STATIC PRESSURE (in. wg) [kPa]									
		1.2 [300]		1.4 [350]		1.6 [400]		1.8 [450]		2.0 [500]	
		RPM	Vdc	RPM	Vdc	RPM	Vdc	RPM	Vdc	RPM	Vdc
756	1800	1954	8.5	2078	9.0	2194	9.5	—	—	—	—
851	1950	1990	8.7	2112	9.2	2227	9.7	—	—	—	—
957	2100	2028	8.8	2148	9.3	2262	9.8	—	—	—	—
1076	2250	2069	9.0	2186	9.5	2298	10.0	—	—	—	—
1211	2400	2111	9.2	2226	9.7	—	—	—	—	—	—
1362	2550	2157	9.4	2268	9.9	—	—	—	—	—	—
1533	2700	2206	9.6	—	—	—	—	—	—	—	—
1724	2850	2258	9.8	—	—	—	—	—	—	—	—
1940	3000	—	—	—	—	—	—	—	—	—	—

Standard Static 1179-2300 RPM

### 50FC-M07 THREE PHASE - MEDIUM STATIC — 5 TON HORIZONTAL SUPPLY (RPM - VDC)

L/s	CFM	AVAILABLE EXTERNAL STATIC PRESSURE (in. wg) [kPa]									
		0.2 [50]		0.4 [100]		0.6 [150]		0.8 [200]		1.0 [250]	
		RPM	Vdc	RPM	Vdc	RPM	Vdc	RPM	Vdc	RPM	Vdc
756	1800	1197	4.7	1361	5.4	1524	6.0	1679	6.6	1822	7.2
851	1950	1271	5.0	1421	5.6	1574	6.2	1721	6.8	1860	7.4
957	2100	1347	5.3	1485	5.9	1627	6.4	1767	7.0	1901	7.5
1076	2250	1425	5.6	1553	6.1	1684	6.7	1816	7.2	1945	7.7
1211	2400	1504	5.9	1622	6.4	1745	6.9	1870	7.4	1992	7.9
1362	2550	1584	6.3	1695	6.7	1809	7.2	1926	7.6	2043	8.1
1533	2700	1665	6.6	1769	7.0	1876	7.4	1986	7.8	2096	8.3
1724	2850	1747	6.9	1844	7.3	1945	7.7	2049	8.1	2153	8.5
1940	3000	1830	7.2	1921	7.6	2016	8.0	2114	8.4	2213	8.7

L/s	CFM	AVAILABLE EXTERNAL STATIC PRESSURE (in. wg) [kPa]									
		1.2 [300]		1.4 [350]		1.6 [400]		1.8 [450]		2.0 [500]	
		RPM	Vdc	RPM	Vdc	RPM	Vdc	RPM	Vdc	RPM	Vdc
756	1800	1954	7.7	2078	8.2	2194	8.7	2304	9.1	2408	9.5
851	1950	1990	7.9	2112	8.3	2227	8.8	2336	9.2	2439	9.6
957	2100	2028	8.0	2148	8.5	2262	8.9	2370	9.4	2472	9.8
1076	2250	2069	8.2	2186	8.6	2298	9.1	2404	9.5	2506	9.9
1211	2400	2111	8.3	2226	8.8	2335	9.2	2441	9.6	—	—
1362	2550	2157	8.5	2268	9.0	2375	9.4	2478	9.8	—	—
1533	2700	2206	8.7	2313	9.1	2417	9.6	2518	10.0	—	—
1724	2850	2258	8.9	2361	9.3	2462	9.7	—	—	—	—
1940	3000	2312	9.1	2411	9.5	2509	9.9	—	—	—	—

Medium Static 1179-2530 RPM

### 50FC-M07 THREE PHASE - HIGH STATIC — 5 TON HORIZONTAL SUPPLY (RPM - VDC)

L/s	CFM	AVAILABLE EXTERNAL STATIC PRESSURE (in. wg) [kPa]									
		0.2 [50]		0.4 [100]		0.6 [150]		0.8 [200]		1.0 [250]	
		RPM	Vdc	RPM	Vdc	RPM	Vdc	RPM	Vdc	RPM	Vdc
756	1800	1197	4.2	1361	4.8	1524	5.4	1679	5.9	1822	6.4
851	1950	1271	4.5	1421	5.0	1574	5.6	1721	6.1	1860	6.6
957	2100	1347	4.7	1485	5.2	1627	5.7	1767	6.2	1901	6.7
1076	2250	1425	5.0	1553	5.5	1684	5.9	1816	6.4	1945	6.9
1211	2400	1504	5.3	1622	5.7	1745	6.2	1870	6.6	1992	7.0
1362	2550	1584	5.6	1695	6.0	1809	6.4	1926	6.8	2043	7.2
1533	2700	1665	5.9	1769	6.2	1876	6.6	1986	7.0	2096	7.4
1724	2850	1747	6.2	1844	6.5	1945	6.9	2049	7.2	2153	7.6
1940	3000	1830	6.5	1921	6.8	2016	7.1	2114	7.5	2213	7.8

L/s	CFM	AVAILABLE EXTERNAL STATIC PRESSURE (in. wg) [kPa]									
		1.2 [300]		1.4 [350]		1.6 [400]		1.8 [450]		2.0 [500]	
		RPM	Vdc	RPM	Vdc	RPM	Vdc	RPM	Vdc	RPM	Vdc
756	1800	1954	6.9	2078	7.3	2194	7.7	2304	8.1	2408	8.5
851	1950	1990	7.0	2112	7.4	2227	7.9	2336	8.2	2439	8.6
957	2100	2028	7.2	2148	7.6	2262	8.0	2370	8.4	2472	8.7
1076	2250	2069	7.3	2186	7.7	2298	8.1	2404	8.5	2506	8.8
1211	2400	2111	7.4	2226	7.8	2335	8.2	2441	8.6	2541	9.0
1362	2550	2157	7.6	2268	8.0	2375	8.4	2478	8.7	2578	9.1
1533	2700	2206	7.8	2313	8.2	2417	8.5	2518	8.9	2616	9.2
1724	2850	2258	8.0	2361	8.3	2462	8.7	2560	9.0	2655	9.4
1940	3000	2312	8.2	2411	8.5	2509	8.8	2604	9.2	2697	9.5

High Static 1179-2836 RPM

## Legend and Notes

Applicable for Electrical Data Tables on pages 27 to 28

### LEGEND

- FLA** — Full Load Amps
- IFM** — Indoor Fan Motor
- LRA** — Locked Rotor Amps
- MCA** — Minimum Circuit Amps
- P.E.** — Power Exhaust
- RLA** — Rated Load Amps

### NOTES:

1. In compliance with NEC requirements for multi-motor and combination load equipment (refer to NEC Articles 430 and 440), the overcurrent protective device for the unit shall be fuse or HACR breaker. Canadian units may be fuse or circuit breaker.
2. **Unbalanced 3-Phase Supply Voltage**  
Never operate a motor where a phase imbalance in supply voltage is greater than 2%. Use the following formula to determine the percentage of voltage imbalance.

$$\% \text{ Voltage Imbalance} = 100 \times \frac{\text{max voltage deviation from average voltage}}{\text{average voltage}}$$

Example: Supply voltage is 230-3-60



- AB = 224 v
- BC = 231 v
- AC = 226 v

$$\text{Average Voltage} = \frac{(224 + 231 + 226)}{3} = \frac{681}{3} = 227$$

Determine maximum deviation from average voltage.

$$(AB) 227 - 224 = 3 \text{ v}$$

$$(BC) 231 - 227 = 4 \text{ v}$$

$$(AC) 227 - 226 = 1 \text{ v}$$

Maximum deviation is 4 v.

Determine percent of voltage imbalance.

$$\% \text{ Voltage Imbalance} = 100 \times \frac{4}{227} = 1.78\%$$

This amount of phase imbalance is satisfactory as it is below the maximum allowable 2%.

**IMPORTANT:** If the supply voltage phase imbalance is more than 2%, contact your local electric utility company immediately.





**50FC\*M07 COOLING ELECTRICAL DATA**

50FC*M UNIT	V-Ph-Hz	UNIT VOLTAGE		COMPRESSOR		OFM (EA)		IFM			POWER EXHAUST	
		RANGE		RLA	LRA	WATTS	FLA	TYPE	EFFCY AT FULL LOAD	FLA	KIT QTY	FLA (EA KIT)
		MIN	MAX									
07	400-3-50	360	440	8.5	67	275	0.8	STD	80%	2.1	1	1.0
								MED	83%	2.5		
								HIGH	83%	3.3		

**50FC\*M07 MCA MOCPS ELECTRICAL DATA**

50FC*M UNIT SIZE	NOM. V-PH-HZ	IFM TYPE	ELECTRIC HEATER			NO CONVENIENCE OUTLET OR UNPOWERED CONVENIENCE OUTLET			
			CRHEATER ***A00	NOM (kW)	FLA	NO POWER EXHAUST			
						MCA	FUSE OR HACR BREAKER	DISCONNECT SIZE	
								FLA	LRA
07	400-3-50	STD	NONE	—	—	14	20	13	72
			333A	6.0	7.2	14	20	13	72
			335A	11.5	13.8	20	20	18	72
			336A	14.0	16.8	24	25	22	72
			337A	21.5	25.9	35	40	32	72
			338A	24.0	28.9	39	40	36	72
		MED	NONE	—	—	14	20	14	73
			333A	6.0	7.2	14	20	14	73
			335A	11.5	13.8	21	25	19	73
			336A	14.0	16.8	25	25	22	73
			337A	21.5	25.9	36	40	33	73
			338A	24.0	28.9	40	40	36	73
		HIGH	NONE	—	—	15	20	14	74
			333A	6.0	7.2	15	20	14	74
			335A	11.5	13.8	22	25	20	74
			336A	14.0	16.8	26	30	23	74
			337A	21.5	25.9	37	40	34	74
			338A	24.0	28.9	41	45	37	74

**50FC\*M07 ELECTRIC HEAT DATA — WITHOUT NON-FUSED DISCONNECT**

50FC*M UNIT SIZE	NOM. V-PH-HZ	IFM TYPE	ELECTRIC HEATER PART NUMBER	NOM (kW)	APPLICATION (kW)	APPLICATION OUTPUT (MBH)	SINGLE POINT OR JUNCTION PART NUMBER CRSINGLEXXXA00
							NO CONVENIENCE OUTLET OR UNPOWERED CONVENIENCE OUTLET
							NO P.E.
07	400-3-50	STD	CRHEATER333A00	6.0	5.5	18.8	—
			CRHEATER335A00	11.5	10.6	36.0	—
			CRHEATER336A00	14.0	12.9	43.9	—
			CRHEATER337A00	21.5	19.7	67.4	037
			CRHEATER338A00	24.0	22.0	75.2	037
			CRHEATER333A00	6.0	5.5	18.8	—
		MED	CRHEATER335A00	11.5	10.6	36.0	—
			CRHEATER336A00	14.0	12.9	43.9	—
			CRHEATER337A00	21.5	19.7	67.4	037
			CRHEATER338A00	24.0	22.0	75.2	037
			CRHEATER333A00	6.0	5.5	18.8	—
			CRHEATER335A00	11.5	10.6	36.0	—
		HIGH	CRHEATER336A00	14.0	12.9	43.9	—
			CRHEATER337A00	21.5	19.7	67.4	037
			CRHEATER338A00	24.0	22.0	75.2	037
			CRHEATER333A00	6.0	5.5	18.8	—
			CRHEATER335A00	11.5	10.6	36.0	—
			CRHEATER336A00	14.0	12.9	43.9	—

# Electrical data (cont)



## 50FC\*M07 ELECTRIC HEAT DATA — WITH NON-FUSED DISCONNECT

50FC*M UNIT SIZE	NOM. V-PH-HZ	IFM TYPE	ELECTRIC HEATER PART NUMBER	NOM (kW)	APPLICATION (kW)	APPLICATION OUTPUT (MBH)	SINGLE POINT OR JUNCTION PART NUMBER CRSINGLEXXXA00
							NO CONVENIENCE OUTLET OR UNPOWERED CONVENIENCE OUTLET
							NO P.E.
07	400-3-50	STD	CRHEATER333A00	6.0	5.5	18.8	—
			CRHEATER335A00	11.5	10.6	36.0	—
			CRHEATER336A00	14.0	12.9	43.9	—
			CRHEATER337A00	21.5	19.7	67.4	037
			CRHEATER338A00	24.0	22.0	75.2	037
		MED	CRHEATER333A00	6.0	5.5	18.8	—
			CRHEATER335A00	11.5	10.6	36.0	—
			CRHEATER336A00	14.0	12.9	43.9	—
			CRHEATER337A00	21.5	19.7	67.4	037
			CRHEATER338A00	24.0	22.0	75.2	037
		HIGH	CRHEATER333A00	6.0	5.5	18.8	—
			CRHEATER335A00	11.5	10.6	36.0	—
			CRHEATER336A00	14.0	12.9	43.9	—
			CRHEATER337A00	21.5	19.7	67.4	037
			CRHEATER338A00	24.0	22.0	75.2	037

## TYPICAL CONTROL WIRING DIAGRAM — 50FC 07 400/3/50 UNIT WITH ELECTRO-MECHANICAL CONTROL AND W7220 ECONOMIZER

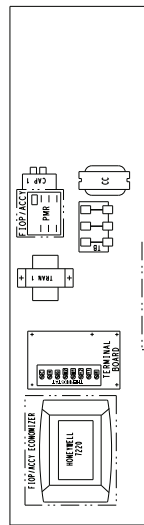

COMPONENT ARRANGEMENT

- NOTES:
1. TERMINAL BOARD JUMPER LAYOUT USES INST. ACTION. TERMINAL BOARD LAYOUT.
  2. TERMINAL BOARD JUMPS 1, 2 AND 3 ARE CUT FOR RESET WHITE SWGT.
  3. REFLECTS OCCUPANCY AND SMOKE SENSORS.
  4. USE RED AS CORSE AND POT AS FINE ADJUSTERS.
  5. 24V AC FROM 24V TRANSFORMER.
  6. 24V AC FROM 24V TRANSFORMER.
  7. HARDWIRE AND CONTROL SET TO "MIN" NUMBER PIN ON TOP 27 PINS AS SHOWN.
  8. WIRE COLOR IS FOR DIFFERENTIATION WITHIN THIS GENERAL IC TO DC.
  9. 34°C COATED IN HEAT SECTION.
  10. TO CONNECT TO A SINGLE STAGE HEATER MORE VIOLET WIRE AT T84 TO CONNECT WITH WHITE WIRE.

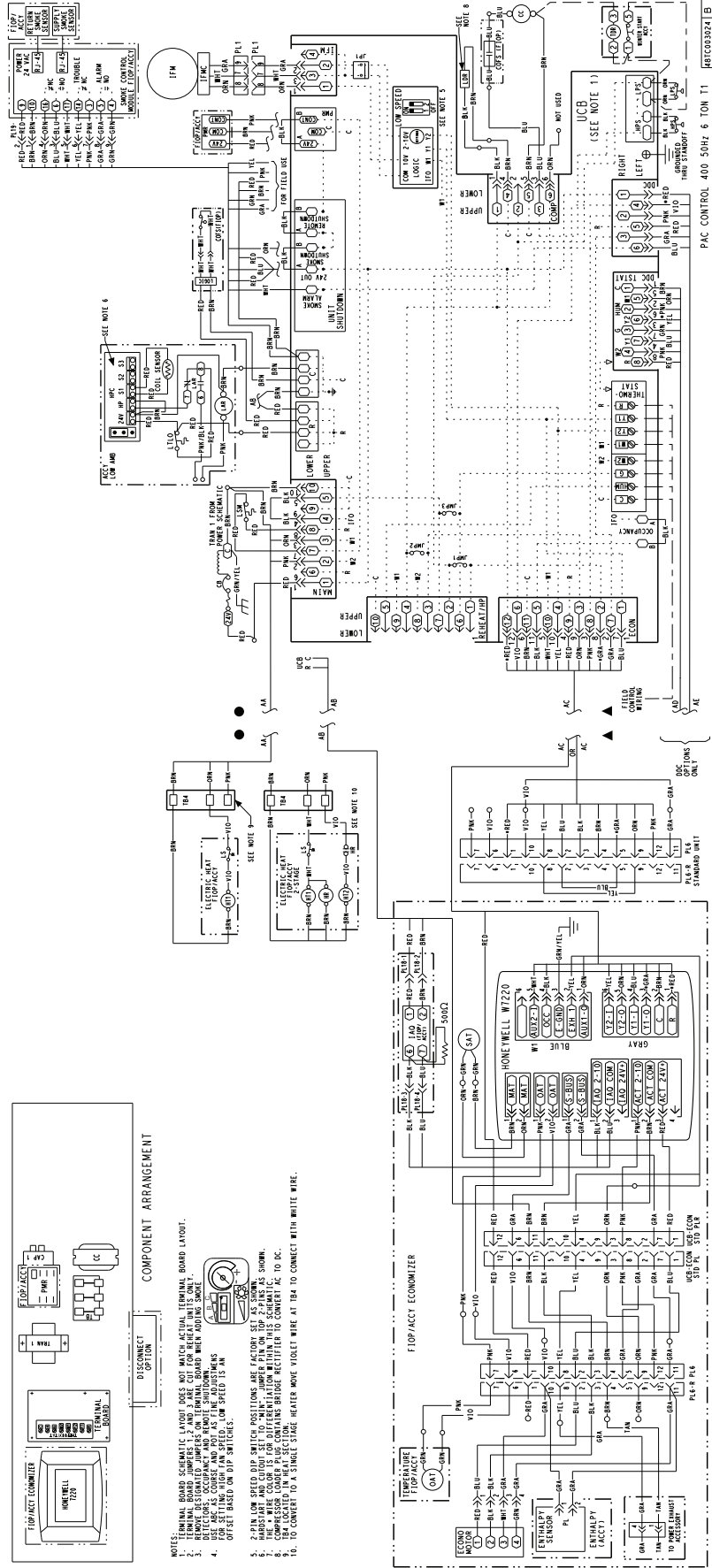

## TYPICAL 50FC 07 POWER WIRING DIAGRAM, 400/3/50 UNIT SHOWN

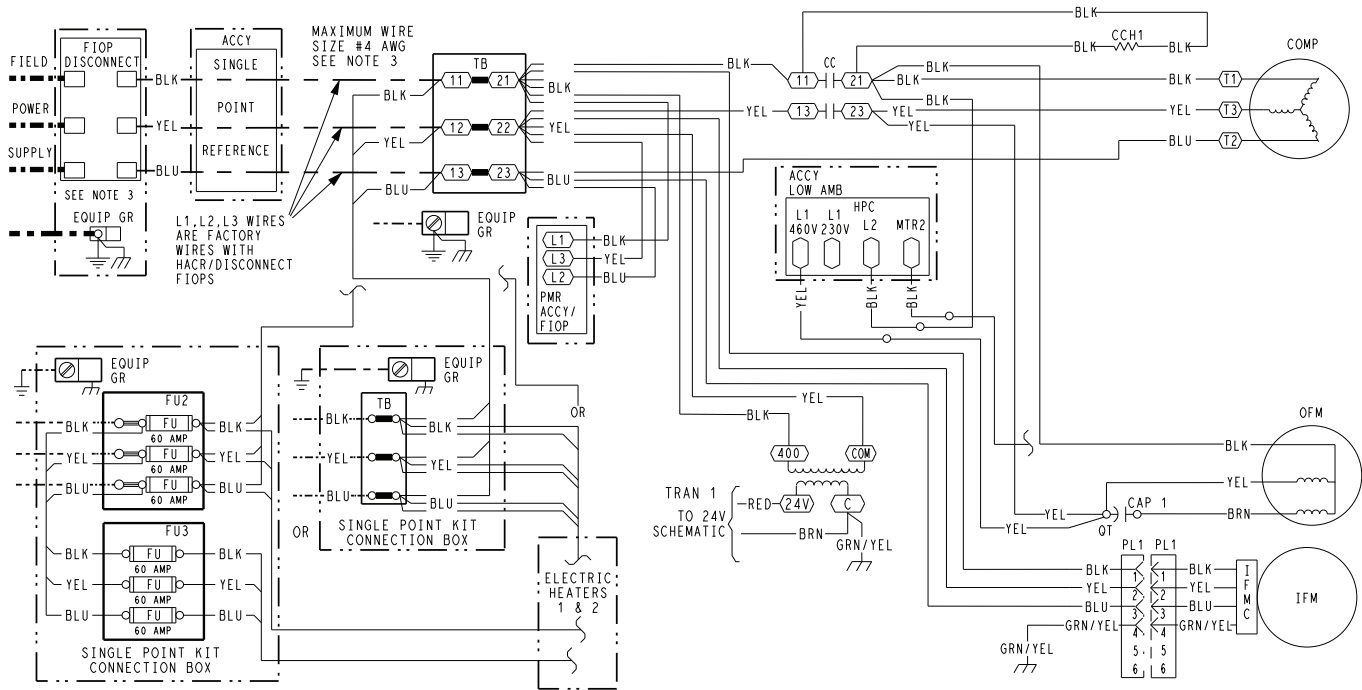

PAC POWER 400-3-50  
6 TON T1

**NOTES**

1. IF ANY OF THE ORIGINAL WIRE FURNISHED MUST BE REPLACED. IT MUST BE REPLACED WITH TYPE 90° C WIRE OR ITS EQUIVALENT.
2. COMPRESSOR AND FAN MOTORS ARE THERMALLY PROTECTED.
3. USE COPPER CONDUCTOR ONLY.
4. DO NOT DISCONNECT POWER PLUG OR SIGNAL WIRE WHILE UNDER LOAD.
5. TRANSFORMER IS DEDICATED BASED ON UNIT VOLTAGE. TAPS ONLY SHOWN TO SIMPLIFY SCHEMATIC.

**LEGEND**

- MARKED WIRE
- TERMINAL (MARKED)
- TERMINAL (UNMARKED)
- TERMINAL BLOCK
- SPLICE
- SPLICE (MARKED)
- FACTORY WIRING
- FIELD CONTROL WIRING
- FIELD POWER WIRING
- CIRCUIT BOARD TRACE
- ACCESSORY OR OPTIONAL WIRING

ACCY	ACCESSORY	G	GROUND
AWG	AMERICAN WIRE GAGE	GRND)	GROUND
BAS	BUILDING AUTOMATION NETWORK	HACR	HEATING, AIR-CONDITIONING, REFRIGERATION BREAKER
CB	CIRCUIT BREAKER	HR	HEATER RELAY
CC	CONTACTOR, COMPRESSOR	HGRH	HOT GAS REHEAT
C	COMMON	HPC	HEAD PRESSURE CONTROL
CAP	CAPACITOR	HPS	HIGH PRESSURE SWITCH
CB	CIRCUIT BREAKER	HUM	HUMIDISTAT
CCH	CRANKCASE HEATER RELAY	IAQ	INDOOR AIR QUALITY SENSORS
CCHTS	CRANKCASE HEATER TEMP SWITCH	CLO	COMPRESSOR LOCKOUT
CLO	COMPRESSOR LOCKOUT	IFM	INDOOR FAN MOTOR
CLV	COOLING LIQUID VALVE	IFMC	INDOOR FAN MOTOR CONTROL
COFS	CONDENSATE OVERFLOW SWITCH	IFO	INDOOR FAN ON SIGNAL
COM	SIGNAL COMMON	IRH	INDOOR RELATIVE HUMIDITY
COMP	COMPRESSOR MOTOR	JMP	JUMPER
DDC	DIRECT DIGITAL CONTROL	L1	LINE 1
DFB	DEFROST BOARD	LA	LOW AMBIENT LOCKOUT
DFT	DEFROST THERMOSTAT	LAR	LOW AMBIENT RELAY
EHR	ELECTRIC HEAT RELAY	LAS	LOW AMBIENT SWITCH
ENTH	ENTHALPY	LDR	COMPRESSOR LOADER
ERV	ENERGY RECOVERY VENTILATOR	LEN	LOCAL EQUIPMENT NETWORK
ESL	ENTHALPY SENSOR - LOW	LOC	LOSS OF CHARGE
FB	FUSE BLOCK	LOOP PWR	CURRENT LOOP POWER
FIOP	FACTORY INSTALLED OPTION	LPS	LOW PRESSURE SWITCH
FPT	FREEZE PROTECTION THERMOSTAT	LS	LIMIT SWITCH
FST	FAN HOUSING TEMP SENSOR	LSM	LIMIT SWITCH (MANUAL RESET)
FU	FUSE	LTLO	LOW TEMP LOCKOUT

MBB	MAIN BASE BOARD
MOV	METAL OXIDE VARISTOR
MTR	MOTOR
OAO	OUTDOOR AIR QUALITY
OAT	OUTDOOR AIR TEMP. SEN
OFM	OUTDOOR FAN MOTOR
OFR	OUTDOOR FAN RELAY
OL	OVERLOAD
PER	POWER EXHAUST RELAY
PH	PHASE
PL	PLUG ASSEMBLY
POT	POTENTIOMETER
PMR	PHASE MONITOR RELAY
PS	PRESSURE SWITCH
PWM	PULSE WIDTH MODULATION
QT	QUADRUPLE TERMINAL
R	THERMOSTAT POWER
RAT	RETURN AIR TEMP. SEN
RDV	REHEAT DISCHARGE VALVE
RH	RELATIVE HUMIDITY
RLV	REHEAT LIQUID VALVE
RNET	LOCAL ACCESS NETWORK
RVS	REVERSING VALVE SOLENOID
SAT	SUPPLY AIR TEMP SENSOR
SDP	SYSTEM DISCHARGE PRESSURE
SPRH	SPACE RELATIVE HUMIDITY
SPT	SPACE TEMPERATURE SENSOR
SPTO	SPACE TEMPERATURE OFFSET
SSP	SYSTEM SUCTION PRESSURE
SW	SWITCH
TB	TERMINAL BLOCK
TDR	TIME DELAY RELAY
TRAN	TRANSFORMER
UCB	UNIT CONTROL BOARD
W1	1st STAGE OF HEATING CALL
W2	2nd STAGE OF HEATING CALL
Y1	1st STAGE OF COOLING CALL
Y2	2nd STAGE OF COOLING CALL

48TC003022 -

## General

The sequence below describes the sequence of operation for an electro-mechanical unit with and without a factory-installed EconoMi\$er® IV (W7212 controller) and X (W7220 controller). For information regarding a direct digital controller, see the start-up, operations, and troubleshooting manual for the applicable controller.

## Electro-Mechanical Units with No Economizer

### Cooling (single stage units)

When the thermostat calls for cooling, terminals G and Y1 are energized. The indoor fan will run at the user set fan speed and the compressor contactor (CC) is energized causing the compressor and outdoor fan to run.

When the thermostat removes the call for Y1, the compressor contactor will de-energize shutting down the compressor and the outdoor fan. When the thermostat removes the call for G, the indoor fan will turn off after the specific unit fan off delay.

### Cooling (two stage units)

When the thermostat calls for cooling, terminals G and Y1 are energized. The indoor fan will run at the low fan speed and the compressor contactor (CC) is energized causing the compressor and outdoor fan to run. The low indoor fan speed is 66% of the user set fan speed and the compressor will run at partial capacity.

If additional cooling is needed, the thermostat will add the call for Y2. This will increase the indoor fan speed to the user set fan speed and energize the compressor loader for full compressor capacity. The outdoor fan is the same speed for Y1 and Y2.

When the thermostat removes the call for Y2 but leaves the Y1, the indoor fan will reduce speed to 66% of the user set fan speed, the compressor loader will turn off, and the outdoor fan will remain on. When the thermostat removes the call for Y1 the compressor contactor will de-energize shutting down the compressor and the outdoor fan. When the thermostat removes the call for G, the indoor fan will turn off after the specific unit fan off delay.

NOTE: Per ASHRAE 90.1-2016 and IECC-2018 standards, during the first stage of cooling operation the Unit Control Board (UCB) will adjust the fan motor speed to provide 66% of the total cfm established for the unit.

## Electric Heating

NOTE: 50FC units are sold as cooling only. If electric heaters are required, use only factory-approved heaters. They will operate as follows.

Units have either 1 or 2 stages of electric heat. When the thermostat calls for heating, power is applied to G and the W1 terminals at the unit. The unit control will energize the indoor fan contactor and the first stage of electric heat. On units with two-stage heating, when additional heating is required, the second stage of electric heat (if equipped) will be energized when power is applied at the W2 terminal on the unit.

**IMPORTANT:** The thermostat must be configured for Electric Heat so it will energize G with the W1 call.

## Electro-mechanical Units with Factory-Installed EconoMi\$er

When free cooling is not available, the compressors will be controlled by the zone thermostat. When free cooling is available, the outdoor-air damper is modulated by the EconoMi\$er IV and X control to provide a 50°F (10°C) to 55°F (13°C) mixed-air temperature into the zone. As the mixed air temperature fluctuates above 55°F (13°C) or below 50°F (10°C) dampers will be modulated (open or close) to bring the mixed-air temperature back within control. If mechanical cooling is utilized with free cooling, the outdoor-air damper will maintain its current position at the time the compressor is started. If the increase in cooling capacity causes the mixed-air temperature to drop below 45°F (7°C), then the outdoor-air damper position will be decreased to the minimum position. If the mixed-air temperature continues to fall, the outdoor-air damper will close. Control returns to normal once the mixed-air temperature rises above 48°F (9°C). The power exhaust fans will be energized and de-energized, if installed, as the outdoor-air damper opens and closes.

If field-installed accessory CO<sub>2</sub> sensors are connected to the EconoMi\$er IV and X control, a demand controlled ventilation strategy will begin to operate. As the CO<sub>2</sub> level in the zone increases above the CO<sub>2</sub> set-point, the minimum position of the damper will be increased proportionally. As the CO<sub>2</sub> level decreases because of the increase in fresh air, the outdoor-air damper will be proportionally closed. For EconoMi\$er IV and X operation, there must be a thermostat call for the fan (G). If the unit is occupied and the fan is on, the damper will operate at minimum position. Otherwise, the damper will be closed.

When the EconoMi\$er IV and X control is in the occupied mode and a call for cooling exists (Y1 on the thermostat), the control will first check for indoor fan operation. If the fan is not on, then cooling will not be activated. If the fan is on, then the control will open the EconoMi\$er IV and X damper to the minimum position.

On the initial power to the EconoMi\$er IV and X control, it will take the damper up to 2<sup>1</sup>/<sub>2</sub> minutes before it begins to position itself. After the initial power-up, further changes in damper position can take up to 30 seconds to initiate. Damper movement from full closed to full open (or vice versa) will take between 1<sup>1</sup>/<sub>2</sub> and 2<sup>1</sup>/<sub>2</sub> minutes. If free cooling can be used as determined from the appropriate changeover command (switch, dry bulb, enthalpy curve, differential dry bulb, or differential enthalpy), then the control will modulate the dampers open to maintain the mixed-air temperature set-point at 50°F (10°C) to 55°F (13°C). If there is a further demand for cooling (cooling second stage — Y2 is energized), then the control will bring on compressor stage 1 to maintain the mixed-air temperature set-point. The EconoMi\$er IV and X damper will be open at maximum position.

2-Speed Note: The EconoMi\$er IV and X controller will adjust the damper position as the Indoor Fan Speed changes, per its configured values.

# Sequence of operation (cont)



## **Heating**

The sequence of operation for the heating is the same as an electro-mechanical unit with no economizer. The only difference is how the economizer acts. The economizer will stay at the Economizer Minimum Position while the evaporator fan is operating. The outdoor-air damper is closed when the indoor fan is not operating. Refer to Service and Maintenance Manual for further details.

## **RTU Open controller (factory option)**

For details on operating 48/50FC units equipped with the factory-installed RTU Open controller option, refer to Factory Installed RTU Open Multi-Protocol Controller Controls, Start-Up, Operation and Troubleshooting manual.



## Minimum operating ambient temperature (cooling)

In mechanical cooling mode, your Carrier rooftop unit can safely operate down to an outdoor ambient temperature of 40°F (4°C). It is possible to provide cooling at lower outdoor ambient temperatures by using less outside air, economizers, and/or accessory low ambient kits.

## Maximum operating ambient temperature (cooling)

The maximum operating ambient temperature for cooling mode is 125°F (52°C). While cooling operation above 125°F (52°C) may be possible, it could cause either a reduction in performance, reliability, or a protective action by the unit's internal safety devices.

## Multiple motor and drive packages

Some applications need larger horsepower motors, some need more airflow, and some need both. Regardless of the case, your Carrier expert has a factory installed combination to meet your application. A wide selection of motors are available, factory installed, to handle nearly any application.

### MINIMUM TEMPERATURE FOR MIXED AIR TEMPERATURE

ALUMINIZED	STAINLESS STEEL
50°F (10°C) Continuous	40°F (4°C) Continuous
45°F (7°C) Intermittent	35°F (2°C) Intermittent

Operating at lower mixed-air temperatures may be possible, if a field-supplied, outdoor air thermostat initiates both heat stages when the temperature is less than the minimum temperatures listed above. Please contact your local Carrier representative for assistance.

## Minimum and maximum airflow (heating and cooling)

To maintain safe and reliable operation of your rooftop, operate within the heating airflow limits during heating mode and cooling airflow limits during cooling mode. Operating above the maximum may cause blow-off, undesired airflow noise, or airflow related problems with the rooftop unit. Operating below the minimum may cause problems with coil freeze-up and unsafe heating operation. Heating and cooling limitations differ when evaluating operating CFM, the minimum value is the HIGHER of the cooling and heating minimum CFM values published on page 5 and the maximum value is the LOWER of the cooling and heating minimum values published on page 5.

## Heating-to-cooling changeover

Your unit will automatically change from heating to cooling mode when using a thermostat with an auto-changeover feature.

## Airflow

All units are draw-through in cooling mode and blow-through in heating mode.

## Outdoor air application strategies

Economizers reduce operating expenses and compressor run time by providing a free source of cooling and a means of ventilation to match application changing needs. In fact, they should be considered for most applications. Also, consider the various economizer control methods and their benefits, as well as sensors required to accomplish your application goals. Please contact your local Carrier representative for assistance.

## Motor limits, break horsepower (BHP)

Due to internal design of Carrier units, the air path, and specially designed motors, the full horsepower (maximum continuous BHP) band, as listed in the Fan Performance tables, can be used with the utmost confidence. There is no need for extra safety factors, as Carrier motors are designed and rigorously tested to use the entire, listed BHP range without either nuisance tripping or premature motor failure.

## Sizing a rooftop

Bigger is not necessarily better. While an air conditioner needs to have enough capacity to meet the design loads, it does not need excess capacity. In fact, excess capacity typically results in very poor part load performance and humidity control.

Using higher design temperatures than ASHRAE recommends for your location, adding "safety factors" to the calculated load, are all signs of oversizing air conditioners. Oversizing the air conditioner leads to poor humidity control, reduced efficiency, higher utility bills, larger indoor temperature swings, excessive noise, and increased wear and tear on the air conditioner.

Rather than oversizing an air conditioner, engineers should "right-size" or even slightly "under-size" air conditioners. Correctly sizing an air conditioner controls humidity better; promotes efficiency; reduces utility bills; extends equipment life, and maintains even, comfortable temperatures. Please contact your local Carrier representative for assistance.

## Low ambient applications

The optional Carrier economizer can adequately cool your space by bringing in fresh, cool outside air. In fact, when so equipped, accessory low-ambient kit may not be necessary. In low ambient conditions, unless the outdoor air is excessively humid or contaminated, economizer-based "free cooling" is the preferred less costly and energy conscious method. In low ambient applications where outside air might not be desired (such as contaminated or excessively humid outdoor environments), your Carrier rooftop can operate to ambient temperatures down to -20°F (-29°C) using the recommended accessory low ambient controller.

Note about this specification:

This specification is in the "Masterformat" as published by the Construction Specification Institute. Please feel free to copy this specification directly into your building spec.



## Cooling Only/Electric Heat Packaged Rooftop HVAC Guide Specifications

Size Range: **5 Nominal Tons**

Carrier Model Number: **50FC\*07 (50 Hz)**

### Part 1 — (23 06 80) Schedules for Decentralized HVAC Equipment

1.01 (23 06 80.13) Decentralized Unitary HVAC Equipment Schedule:

- A. (23 06 80.13.A.) Rooftop unit (RTU) schedule:
1. Schedule is per the project specification requirements.

### Part 2 — (23 07 16) HVAC equipment insulation

2.01 (23 07 16.13) Decentralized, Rooftop Units:

- A. (23 07 16.13.A.) Evaporator fan compartment:
1. Interior cabinet surfaces shall be insulated with a minimum 1/2-in. thick, minimum 1 1/2-lb density, flexible fiberglass insulation bonded with a phenolic binder, neoprene coated on the air side.
  2. Insulation and adhesive shall meet NFPA 90A requirements for flame spread and smoke generation.
- B. (23 07 16.13.B.) Electric Heat Compartment:
1. Aluminum foil-faced fiberglass insulation shall be used.
  2. Insulation and adhesive shall meet NFPA 90A requirements for flame spread and smoke generation.

### Part 3 — (23 09 13) Instrumentation and control devices for HVAC

3.01 (23 09 13.23) Sensors and Transmitters:

- A. (23 09 13.23.A.) RTU Open Protocol, Direct Digital Controller:
1. Shall be ASHRAE 62 compliant.
  2. Shall accept 18 - 30VAC, 50 - 60Hz, and consumer 15VA or less power.
  3. Shall have an operating temperature range from -40°F (-40°C) to 130°F (54°C), 10% to 90% RH (non-condensing).
  4. Shall include built-in protocol for BACnet<sup>1</sup> (MS/TP and PTP modes), Modbus<sup>2</sup> (RTU and ASCII), Johnson N2 and LonWorks<sup>3</sup>.

1. BACnet is a registered trademark of ASHRAE (American Society of Heating, Refrigerating and Air-Conditioning Engineers).  
2. Modbus is a registered trademark of Schneider Electric.  
3. LonWorks is a registered trademark of Echelon Corporation.

LonWorks Echelon processor required for all Lon applications shall be contained in separate communication board.

5. Shall allow access of up to 62 network variables (SNVT). Shall be compatible with all open controllers.
6. Baud rate controller shall be selectable using a dipswitch.
7. Shall have an LED display independently showing the status of serial communication, running, errors, power, all digital outputs, and all analog inputs.
8. Shall accept the following inputs: space temperature, setpoint adjustment, outdoor air temperature, indoor air quality, outdoor air quality, compressor lock-out, fire shutdown, enthalpy switch, and fan status/filter status/humidity/remote occupancy.
9. Shall provide the following outputs: economizer, fan, cooling stage 1, cooling stage 2, heat stage 1, heat stage 2, exhaust, reversing valve/high fan speed.
10. Shall have built-in surge protection circuitry through solid-state polyswitches. Polyswitches shall be used on incoming power and network connections. Polyswitches will return to normal when the "trip" condition clears.
11. Shall have a battery back-up capable of a minimum of 10,000 hours of data and time clock retention during power outages.
12. Shall have built-in support for Carrier technician tool.
13. Shall include an RS-485 protocol communication port, an access port for connection of either a computer or a Carrier technician tool, an RS-485 port for network communication to intelligent space sensors and displays, and a port to connect an optional LonWorks communications card.
14. Software upgrades will be accomplished by either local or remote download. No software upgrades through chip replacements are allowed.

### Part 4 — (23 09 33) Electric and Electronic Control System for HVAC

4.01 (23 09 33.13) Decentralized, Rooftop Units:

- A. (23 09 33.13.A.) General:
1. Shall be complete with self-contained low-voltage control circuit protected by a resettable circuit breaker on the 24-v transformer side. Transformer shall have 75VA capability.
  2. Shall utilize color-coded wiring.
  3. Shall include a Unit Control Board to conveniently and safely provide connection points for vital control functions such as: smoke detectors, phase monitor, economizer, thermostat, DDC control options, and low and high pressure

switches. Controller shall also provide an intuitive means to adjust the indoor fan speed through a simple switch and pot adjustment design.

4. Unit shall include a minimum of one 8-pin screw terminal connection board for connection of control wiring.

B. (23 09 33.13.B.) Safeties:

1. Compressor over-temperature, over-current. High internal pressure differential.
2. Low pressure switch.
  - a. Low pressure switch shall use different color wire than the high pressure switch. The purpose is to assist the installer and service technician to correctly wire and or troubleshoot the rooftop unit.
3. High pressure switch.
  - a. High pressure switch shall use different color wire than the low pressure switch. The purpose is to assist the installer and service technician to correctly wire and or troubleshoot the rooftop unit.
4. Automatic reset, motor thermal overload protector.

**Part 5 — (23 09 93) Sequence of Operations for HVAC Controls**

5.01 (23 09 93.13) Decentralized, Rooftop Units:

A. (23 09 93.13.A.) INSERT SEQUENCE OF OPERATION

**Part 6 — (23 40 13) Panel Air Filters**

6.01 (23 40 13.13) Decentralized, Rooftop Units:

A. (23 40 13.13.A.) Standard filter section:

1. Shall consist of factory installed, low velocity, disposable 2-in. thick fiberglass filters of commercially available sizes.
2. Unit shall use only one filter size. Multiple sizes are not acceptable.
3. Filters shall be accessible through an access panel with “no-tool” removal as described in the unit cabinet section of this specification (23 81 19.13.G).

**Part 7 — (23 81 19) Self-Contained Air Conditioners**

7.01 (23 81 19.13) Small-Capacity Self-Contained Air Conditioners:

A. (23 81 19.13.A.) General:

1. Outdoor, rooftop mounted, electrically controlled, heating and cooling unit utilizing a fully hermetic scroll compressor(s) for cooling duty and optional electric heat for heating duty.
2. Factory assembled, single-piece heating and cooling rooftop unit. Contained within the unit enclosure shall be all factory wiring, piping, controls, and special features required prior to field start-up.

3. Unit shall use Puron® (R-410A) refrigerant.
4. Unit shall be installed in accordance with the manufacturer’s instructions.
5. Unit must be selected and installed in compliance with local, state, and federal codes.

B. (23 81 19.13.B.) Quality Assurance:

1. Unit meets ASHRAE 90.1 minimum efficiency requirements.
2. Unit shall be rated in accordance with AHRI Standards 340/360.
3. Unit shall be designed to conform to ASHRAE 15.
4. Unit shall be UL-tested and certified in accordance with ANSI Z21.47 Standards and UL-listed and certified under Canadian standards as a total package for safety requirements.
5. Insulation and adhesive shall meet NFPA 90A requirements for flame spread and smoke generation.
6. Unit casing shall be capable of withstanding 500 hour salt spray exposure per ASTM B117 (scribed specimen).
7. Unit shall be designed in accordance with ISO 9001, and shall be manufactured in a facility registered by ISO 9001:2015.
8. Roof curb shall be designed to conform to NRCA Standards.
9. Unit shall be subjected to a completely automated run test on the assembly line. The data for each unit will be stored at the factory, and must be available upon request.
10. Unit shall be designed in accordance with UL Standard 1995, including tested to withstand rain.
11. Unit shall be constructed to prevent intrusion of snow and tested to prevent snow intrusion into the control box up to 40 mph.
12. Unit shake tested to assurance level 1, ASTM D4169 to ensure shipping reliability.

C. (23 81 19.13.C.) Delivery, Storage, and Handling:

1. Unit shall be stored and handled per manufacturer’s recommendations.
2. Lifted by crane requires either shipping top panel or spreader bars.
3. Unit shall only be stored or positioned in the upright position.

D. (23 81 19.13.D.) Project Conditions:

As specified in the contract.

E. (23 81 19.13.E.) Operating Characteristics:

1. Unit shall be capable of starting and running at 125°F (52°C) ambient outdoor temperature, meeting maximum load criteria of AHRI Standard 340/360 at ±10% voltage.
2. Compressor with standard controls shall be capable of operation down to 40°F (4°C),

ambient outdoor temperatures. Accessory winter start kit is necessary if mechanically cooling at ambient temperatures down to 25°F (-4°C).

3. Unit shall discharge supply air vertically or horizontally as shown on contract drawings.
  4. Unit shall be factory configured for vertical supply and return configurations.
  5. Unit shall be field convertible from vertical to horizontal airflow on all models. No special kit required.
  6. Unit shall be capable of mixed operation: vertical supply with horizontal return or horizontal supply with vertical return.
- F. (23 81 19.13.F.) Electrical Requirements:  
Main power supply voltage, phase, and frequency must match those required by the manufacturer.
- G. (23 81 19.13.G.) Unit Cabinet:
1. Unit cabinet shall be constructed of galvanized steel, and shall be bonderized and coated with a prepainted baked enamel finish on all externally exposed surfaces.
  2. Unit cabinet exterior paint shall be: film thickness, (dry) 0.003-in. minimum, gloss (per ASTM D523, 60°F/16°C): 60, Hardness: H-2H Pencil hardness.
  3. Evaporator fan compartment interior cabinet insulation shall conform to AHRI Standard 340/360 minimum exterior sweat criteria. Interior surfaces shall be insulated with a minimum 1/2-in. thick, 1 lb density, flexible fiberglass insulation, neoprene coated on the air side. Aluminum foil-faced fiberglass insulation shall be used in the heat compartment.
  4. Base of unit shall have a minimum of four locations for thru-the-base gas and electrical connections (factory-installed or field-installed), standard.
  5. Base Rail:
    - a. Unit shall have base rails on a minimum of 2 sides.
    - b. Holes shall be provided in the base rails for rigging shackles to facilitate maneuvering and overhead rigging.
    - c. Holes shall be provided in the base rail for moving the rooftop by fork truck.
    - d. Base rail shall be a minimum of 16 gage thickness.
  6. Condensate pan and connections:
    - a. Shall be a sloped condensate drain pan made of a corrosion resistant material.
    - b. Shall comply with ASHRAE Standard 62.
    - c. Shall use a 3/4-in. 14 NPT drain connection, possible either through the bottom or side of the drain pan. Connection shall be made per manufacturer's recommendations.
7. Top panel:  
Shall be a single piece top panel on all sizes.
  8. Electrical Connections:
    - a. All unit power wiring shall enter unit cabinet at a single, factory prepared, knockout location.
    - b. Thru-the-base capability.
      - 1) Standard unit shall have a thru-the-base electrical location(s) using a raised, embossed portion of the unit basepan.
      - 2) Optional, factory approved, water-tight connection method must be used for thru-the-base electrical connections.
      - 3) No basepan penetration, other than those authorized by the manufacturer, is permitted.
  9. Component access panels (standard):
    - a. Cabinet panels shall be easily removable for servicing.
    - b. Unit shall have one factory installed, tool-less, removable, filter access panel.
    - c. Panels covering control box, indoor fan, indoor fan motor, gas components (where applicable), and compressors shall have molded composite handles.
    - d. Handles shall be UV modified, composite. They shall be permanently attached, and recessed into the panel.
    - e. Screws on the vertical portion of all removable access panel shall engage into heat resistant, molded composite collars.
    - f. Collars shall be removable and easily replaceable using manufacturer recommended parts.
- H. (23 81 19.13.H.) Coils:
1. Standard Aluminum Fin-Copper Tube Coils:
    - a. Standard evaporator and condenser coils shall have aluminum lanced plate fins mechanically bonded to seamless internally grooved copper tubes with all joints brazed.
    - b. Evaporator coils shall be leak tested to 150 psig, pressure tested to 450 psig, and qualified to UL 1995 burst test at 1775 psig.
    - c. Condenser coils shall be leak tested to 150 psig, pressure tested to 650 psig, and qualified to UL 1995 burst test at 1980 psig.
  2. Optional Pre-coated aluminum-fin condenser coils:
    - a. Shall have a durable epoxy-phenolic coating to provide protection in mildly corrosive coastal environments.
    - b. Coating shall be applied to the aluminum fin stock prior to the fin stamping process to create an inert barrier between the aluminum fin and copper tube.



- c. Epoxy-phenolic barrier shall minimize galvanic action between dissimilar metals.
  - d. Corrosion durability of fin stock shall be confirmed through testing to be no less than 1000 hours salt spray per ASTM B117-90.
  - e. Corrosion durability of fin stock shall be confirmed through testing to have no visible corrosion after 48 hour immersion in a room temperature solution of 5% salt, 1% acetic acid.
  - f. Fin stock coating shall pass 2000 hours of the following: one week exposure in the prohesion chamber followed by one week of accelerated ultraviolet light testing. Prohesion chamber: the solution shall contain 3.5% sodium chloride and 0.35% ammonium sulfate. The exposure cycle is one hour of salt fog application at ambient followed by one hour drying at 95°F (35°C).
3. Optional Copper-fin evaporator and condenser coils:
- a. Shall be constructed of copper fins mechanically bonded to copper tubes and copper tube sheets.
  - b. Galvanized steel tube sheets shall not be acceptable.
  - c. A polymer strip shall prevent coil assembly from contacting the sheet metal coil pan to minimize potential for galvanic corrosion between coil and pan.
4. Optional E-coated aluminum-fin evaporator and condenser coils:
- a. Shall have a flexible epoxy polymer coating uniformly applied to all coil surface areas without material bridging between fins.
  - b. Coating process shall ensure complete coil encapsulation of tubes, fins and headers.
  - c. Color shall be high gloss black with gloss per ASTM D523-89.
  - d. Uniform dry film thickness from 0.8 to 1.2 mil on all surface areas including fin edges.
  - e. Superior hardness characteristics of 2H per ASTM D3363-92A and cross-hatch adhesion of 4B-5B per ASTM D3359-93.
  - f. Impact resistance shall be up to 160 in.-lb (ASTM D2794-93).
  - g. Humidity and water immersion resistance shall be up to minimum 1000 and 250 hours respectively (ASTM D2247-92 and ASTM D870-92).
  - h. Corrosion durability shall be confirmed through testing to be no less than 1000 hours salt spray per ASTM B117-90.
- I. (23 81 19.13.I.) Refrigerant Components:
- 1. Refrigerant circuit shall include the following control, safety, and maintenance features:
    - a. TXV orifice metering system on 07 size models shall include a multiple feed distribution system that optimizes coil performance.
    - b. Refrigerant filter drier - Solid core design.
    - c. Service gage connections on suction and discharge lines.
    - d. Pressure gage access through a specially designed access port in the top panel of the unit.
  - 2. There shall be gage line access port in the skin of the rooftop, covered by a black, removable plug.
    - a. The plug shall be easy to remove and replace.
    - b. When the plug is removed, the gage access port shall enable maintenance personnel to route their pressure gage lines.
    - c. This gage access port shall facilitate correct and accurate condenser pressure readings by enabling the reading with the compressor access panel on.
    - d. The plug shall be made of a leak proof, UV-resistant, composite material.
  - 3. Compressors:
    - a. Unit shall use fully hermetic, scroll compressor for each independent refrigeration circuit.
    - b. Compressor motors shall be cooled by refrigerant gas passing through motor windings.
    - c. Compressors shall be internally protected from high discharge temperature conditions.
    - d. Compressors shall be protected from an over-temperature and over-ampereage conditions by an internal, motor overload device.
    - e. Compressor shall be factory mounted on rubber grommets.
    - f. Compressor motors shall have internal line break thermal, current overload and high pressure differential protection.
    - g. Crankcase heaters shall not be required for normal operating range, unless required by compressor manufacturer due to refrigerant charge limits.
    - h. Compressor on 07 models shall be a two stage cooling capacity design.
- J. (23 81 19.13.J.) Filter Section:
- 1. Filters access is specified in the unit cabinet section of this specification.
  - 2. Filters shall be held in place by a pivoting filter tray, facilitating easy removal and installation.
  - 3. Shall consist of factory installed, low velocity, throw-away 2-in. thick fiberglass filters.

4. Filters shall be standard, commercially available sizes.
5. Only one size filter per unit is allowed.
- K. (23 81 19.13.K.) Evaporator Fan and Motor with EcoBlue™ Technology:
  1. Direct Drive Evaporator fan motor:
    - a. Shall be a ECM motor design.
    - b. Shall have permanently lubricated bearings.
    - c. Shall have inherent automatic-reset thermal overload protection.
    - d. Shall have slow ramp up to speed capabilities.
    - e. Shall require no fan/motor belts for operation, adjustments and or initial fan speed set up.
    - f. Fan DC voltage set up on Unit Control Board can eliminate the need of removal of blower access door, required on conventional belt drive systems.
    - g. Shall be internally protected from electrical phase reversal and loss.
  2. Evaporator Fan:
    - a. Shall be easily set with dedicated selection switch and adjustment pot on unit control board.
    - b. On 07 size model with two stage cooling capacity control, the indoor fan speed is automatically controlled to meet the code-compliant 66% low fan speed and 100% at full fan speed operation.
    - c. Blower fan shall be a Vane Axial fan design with 75% less moving parts than a conventional belt drive system.
    - d. Shall be constructed of a cast aluminum stator and high impact composite material on rotor and air inlet casing.
    - e. Shall be a patented / pending design with a corrosion resistant material and dynamically balanced.
    - f. Shall have slow ramp up to speed capabilities to help reduce sound and comfort issues typically associated with single speed belt drive systems.
    - g. Shall be a slide out design with two screw removal.
  3. Shall include an easily accessible unit Control Board to conveniently and safely provide connection points for vital control functions such as: smoke detectors, phase monitor, gas controller, economizer, thermostat, DDC control options, and low and high pressure switches. Controller shall also provide an intuitive means to adjust the indoor fan speed through a simple switch and pot adjustment design.
- L. (23 81 19.13.L.) Condenser Fans and Motors:
  1. Condenser fan motors:
    - a. Shall be a totally enclosed motor.
    - b. Shall use permanently lubricated bearings.
    - c. Shall have inherent thermal overload protection with an automatic reset feature.
    - d. Shall use a shaft-down design on all sizes.
  2. Condenser Fans:
    - a. Shall be a direct-driven propeller type fan constructed of high impact composite material.
    - b. Shall have high impact composite blades completely formed into one piece without blade fasteners or connectors and shall be dynamically balanced.
- M. (23 81 19.13.M.) Special Features Options and Accessories:
  1. Integrated EconoMi\$er® IV, EconoMi\$er2, and EconoMi\$er X low leak rate models.
    - a. Integrated, gear driven opposing modulating blade design type capable of simultaneous economizer and compressor operation.
    - b. Independent modules for vertical or horizontal return configuration shall be available. Vertical return modules shall be available as a factory installed option.
    - c. Damper blades shall be galvanized steel with composite gears. Plastic or composite blades on intake or return shall not be acceptable.
    - d. Shall include all hardware and controls to provide free cooling with outdoor air when temperature and/or humidity are below setpoints.
    - e. Shall be equipped with gear driven dampers for both the outdoor ventilation air and the return air for positive air stream control.
    - f. Standard leak rate shall be equipped with dampers not to exceed 2% leakage at 1 in. wg pressure differential.
    - g. Economizer controller on EconoMi\$er IV models shall be Honeywell W7212 that provides:
      - 1) Combined minimum and DCV maximum damper position potentiometers with compressor staging relay.
      - 2) Functions with solid-state analog enthalpy or dry bulb changeover control sensing.
      - 3) Contain LED indicates for: when free cooling is available, when module is in DCV mode, when exhaust fan contact is closed.

- h. Economizer controller on EconoMi\$er® X models shall be the Honeywell W7220 that provides:
    - 1) 2-line LCD interface screen for setup, configuration and troubleshooting.
    - 2) On-board Fault Detection and Diagnostics (FDD) that senses and alerts when the economizer is not operating properly, per California Title 24, ASHRAE 90.1 and IECC<sup>1</sup>.
    - 3) Sensor failure loss of communication identification.
    - 4) Automatic sensor detection.
    - 5) Capabilities for use with multiple-speed or single speed indoor fan systems.
    - 6) Utilize digital sensors: Dry bulb and Enthalpy.
  - i. Economizer controller on EconoMi\$er 2 models with RTU Open shall be a 4 to 20mA design controlled directly by the controller. RTU Open meets California Title 24, ASHRAE 90.1 and IECC Fault Detection and Diagnostic (FDD) requirements.
  - j. Shall be capable of introducing up to 100% outdoor air.
  - k. Shall be equipped with a barometric relief damper capable of relieving up to 100% return air and contain seals that meet ASHRAE 90.1 requirements.
  - l. Shall be designed to close damper(s) during loss-of-power situations with spring return built into motor.
  - m. Dry bulb outdoor air temperature sensor shall be provided as standard. Enthalpy sensor is also available on factory installed only. Outdoor air sensor setpoint shall be adjustable and shall range from 40°F to 100°F (4°C to 38°C). Additional sensor options shall be available as accessories.
  - n. The economizer controller shall also provide control of an accessory power exhaust unit function. Factory set at 100%, with a range of 0% to 100%.
  - o. The economizer shall maintain minimum airflow into the building during occupied period and provide design ventilation rate for full occupancy.
  - p. Dampers shall be completely closed when the unit is in the unoccupied mode.
  - q. Economizer controller shall accept a 2 to 10 vdc CO<sub>2</sub> sensor input for IAQ/DCV control. In this mode, dampers shall modulate the outdoor air damper to provide ventilation based on the sensor input.
  - r. Compressor lockout temperature on W7220 control is adjustable from -45°F to 80°F, set at a factory default of 32°F. W7212 control opens at 35°F (2°C) and closes at 50°F (10°C).
  - s. Actuator shall be direct coupled to economizer gear. No linkage arms or control rods shall be acceptable.
  - t. Economizer controller shall provide indications when in free cooling mode, in the DCV mode, or the exhaust fan contact is closed.
2. Integrated EconoMi\$er2 and EconoMi\$er X Ultra Low Leak rate models. (Factory-installed and field-installed on all.)
- a. Integrated, gear driven opposing modulating blade design type capable of simultaneous economizer and compressor operation.
  - b. Independent modules for vertical or horizontal return configuration shall be available. Vertical return modules shall be available as a factory-installed option.
  - c. Damper blades shall be galvanized steel with composite gears. Plastic or composite blades on intake or return shall not be acceptable.
  - d. Shall include all hardware and controls to provide free cooling with outdoor air when temperature and/or humidity are below setpoints.
  - e. Shall be equipped with gear driven dampers for both the outdoor ventilation air and the return air for positive air stream control.
  - f. Ultra Low Leak design meets California Title 24 section 140.4 and ASHRAE 90.1 requirements for 4 cfm per sq.ft. on the outside air dampers and 10 cfm per sq. ft. on the return dampers.
  - g. Economizer controller on EconoMi\$er X models shall be the Honeywell W7220 that provides:
    - 1) 2-line LCD interface screen for setup, configuration and troubleshooting.
    - 2) On-board Fault Detection and Diagnostics (FDD) that senses and alerts when the economizer is not operating properly, per California Title 24, ASHRAE 90.1 and IECC.
    - 3) Sensor failure loss of communication identification.
    - 4) Automatic sensor detection.
    - 5) Capabilities for use with multiple-speed indoor fan systems.
    - 6) Utilize digital sensors: Dry bulb and Enthalpy.
  - h. Economizer controller on EconoMi\$er 2 models with RTU Open shall be a 4-20mA design controlled directly by the controller. RTU Open meets California Title 24, ASHRAE 90.1 and

---

1. IECC is a registered trademark of the International Code Council, Inc.



- IECC Fault Detection and Diagnostic (FDD) requirements.
- i. Shall be capable of introducing up to 100% outdoor air.
  - j. Shall be equipped with a barometric relief damper capable of relieving up to 100% return air and contain seals that meet ASHRAE 90.1 requirements.
  - k. Shall be designed to close damper(s) during loss-of-power situations with spring return built into motor.
  - l. Dry bulb outdoor air temperature sensor shall be provided as standard. Enthalpy sensor is also available on factory installed only. Outdoor air sensor setpoint shall be adjustable and shall range from 40°F to 100°F (4°C to 38°C). Additional sensor options shall be available as accessories.
  - m. The economizer controller shall also provide control of an accessory power exhaust unit function. Factory set at 100%, with a range of 0% to 100%.
  - n. The economizer shall maintain minimum air-flow into the building during occupied period and provide design ventilation rate for full occupancy.
  - o. Dampers shall be completely closed when the unit is in the unoccupied mode.
  - p. Economizer controller shall accept a 2 to 10 vdc CO<sub>2</sub> sensor input for IAQ/DCV control. In this mode, dampers shall modulate the outdoor air damper to provide ventilation based on the sensor input.
  - q. Compressor lockout temperature on W7220 control is adjustable from -45°F to 80°F (-43°C to 27°C), set at a factory default of 32°F (0°C). W7212 control opens at 35°F (2°C) and closes at 50°F (10°C).
  - r. Actuator shall be direct coupled to economizer gear. No linkage arms or control rods shall be acceptable.
  - s. Economizer controller shall provide indications when in free cooling mode, in the DCV mode, or the exhaust fan contact is closed.
3. Two-Position Damper (Factory-installed and field-installed on all models)
    - a. Damper shall be a Two-Position Damper. Damper travel shall be from the full closed position to the field adjustable %-open setpoint.
    - b. Damper shall include adjustable damper travel from 25% to 100% (full open).
    - c. Damper shall include single or dual blade, gear driven dampers and actuator motor.
    - d. Actuator shall be direct coupled to damper gear. No linkage arms or control rods shall be acceptable.
    - e. Damper will admit up to 100% outdoor air for applicable rooftop units.
    - f. Damper shall close upon indoor (evaporator) fan shutoff and/or loss of power.
    - g. The damper actuator shall plug into the rooftop unit's wiring harness plug. No hard wiring shall be required.
    - h. Outside air hood shall include aluminum water entrainment filter.
  4. Manual damper (field-installed only):
    - a. Manual damper package shall consist of damper, air inlet screen, and rain hood which can be preset to admit up to 25% or 50% outdoor air for year round ventilation.
  5. Low Ambient Control Package:
    - a. Controller shall control coil head pressure by condenser fan speed modulation or condenser fan cycling and wind baffles.
    - b. Shall consist of solid-state control and condenser coil temperature sensor to maintain condensing temperature between 90°F (32°C) and 110°F (43°C) at outdoor ambient temperatures down to -20°F (-29°C).
  6. Condenser Coil Hail Guard Assembly (Factory-installed on 3 Phase Models Only. Field-installed on all 3 and 1 Phase Models.)
    - a. Shall protect against damage from hail.
    - b. Shall be either hood style or louvered.
  7. Unit-Mounted, Non-Fused Disconnect Switch (Available on units with MOCs of 80 amps or less):
    - a. Switch shall be factory installed, internally mounted.
    - b. National Electric Code (NEC) and UL approved non-fused switch shall provide unit power shutoff.
    - c. Shall be accessible from outside the unit.
    - d. Shall provide local shutdown and lockout capability.
    - e. Sized only for the unit as ordered from the factory. Does not accommodate field-installed devices.
  8. Thru-the-Base Connectors:
    - a. Kits shall provide connectors to permit gas and electrical connections to be brought to the unit through the unit basepan.
    - b. Minimum of four connection locations per unit.
  9. Propeller Power Exhaust:
    - a. Power exhaust shall be used in conjunction with an integrated economizer.
    - b. Independent modules for vertical or horizontal return configurations shall be available.
    - c. Horizontal power exhaust is shall be mounted in return ductwork.

- d. Power exhaust shall be controlled by economizer controller operation. Exhaust fans shall be energized when dampers open past the 0 to 100% adjustable setpoint on the economizer control.
10. Roof Curbs (Vertical):
    - a. Full perimeter roof curb with exhaust capability providing separate air streams for energy recovery from the exhaust air without supply air contamination.
    - b. Formed galvanized steel with wood nailer strip and shall be capable of supporting entire unit weight.
    - c. Permits installation and securing of ductwork to curb prior to mounting unit on the curb.
  11. Outdoor Air Enthalpy Sensor:

The outdoor air enthalpy sensor shall be used to provide single enthalpy control. When used in conjunction with a return air enthalpy sensor, the unit will provide differential enthalpy control. The sensor allows the unit to determine if outside air is suitable for free cooling.
  12. Return Air Enthalpy Sensor:

The return air enthalpy sensor shall be used in conjunction with an outdoor air enthalpy sensor to provide differential enthalpy control.
  13. Indoor Air Quality (CO<sub>2</sub>) Sensor:
    - a. Shall be able to provide demand ventilation indoor air quality (IAQ) control.
    - b. The IAQ sensor shall be available in duct mount, wall mount, or wall mount with LED display. The setpoint shall have adjustment capability.
  14. Smoke detectors (factory-installed only):
    - a. Shall be a four-wire controller and detector.
    - b. Shall be environmental compensated with differential sensing for reliable, stable, and drift-free sensitivity.
    - c. Shall use magnet-activated test/reset sensor switches.
    - d. Shall have tool-less connection terminal access.
    - e. Shall have a recessed momentary switch for testing and resetting the detector.
    - f. Controller shall include:
      - 1) One set of normally open alarm initiation contacts for connection to an initiating device circuit on a fire alarm control panel.
      - 2) Two Form-C auxiliary alarm relays for interface with rooftop unit or other equipment.
      - 3) One Form-C supervision (trouble) relay to control the operation of the Trouble LED on a remote test/reset station.
  - 4) Capable of direct connection to two individual detector modules.
  - 5) Can be wired to up to 14 other duct smoke detectors for multiple fan shut-down applications.
15. Winter Start Kit:
    - a. Shall contain a bypass device around the low pressure switch.
    - b. Shall be required when mechanical cooling is required down to 25°F (-4°C).
    - c. Shall not be required to operate on an economizer when below an outdoor ambient of 40°F (4°C).
  16. Time Guard:
    - a. Shall prevent compressor short-cycling by providing a 5 minute delay (±2 minutes) before restarting a compressor after shut-down for any reason.
    - b. One device shall be required per compressor.
  17. Hinged Access Panels:
    - a. Shall provide easy access through integrated quarter turn latches.
    - b. Shall be on major panels of: filter, control box, fan motor, and compressor.
  18. Condensate overflow switch:
    - a. This sensor and related controller monitors the condensate level in the drain pan and shuts down compression operation when overflow conditions occur. It includes:
      - 1) Indicator light — solid red (more than 10 seconds on water contact – compressors disabled), blinking red (sensor disconnected).
      - 2) 10 second delay to break — eliminates nuisance trips from splashing or waves in pan (sensor needs 10 seconds of constant water contact before tripping).
      - 3) Disables the compressor(s) operation when condensate plug is detected, but still allows fans to run for Economizer.
  19. MERV-8 Return Air filters:

Factory option to upgrade standard unit filters to MERV-8 filters.
  20. Phase Monitor Control:
    - a. Shall monitor the sequence of three phase electrical system to provide a phase reversal protection.
    - b. Shall monitor the three phase voltage inputs to provide a phase loss protection for the three phase device.
    - c. Will work on either a Delta or Wye power connection.

### 21. Horn/Strobe Annunciator:

- a. Provides an audible/visual signaling device for use with factory-installed option or field installed accessory smoke detectors.
  - 1) Requires installation of a field-supplied 24-v transformer suitable for 4.2 VA (AC) or 3.0 VA (DC) per horn/strobe accessory.
  - 2) Requires field-supplied electrical box, North American 1-gang box, 2-in. (51 mm) x 4-in. (102 mm).
  - 3) Shall have a clear colored lens.

### 22. Electric Heat:

- a. Heating Section:
  - 1) Heater element open coil resistance wire, nickel-chrome alloy, 0.29 inches inside diameter, strung through ceramic insulators mounted on metal frame. Coil ends are staked and welded to terminal screw slots.
  - 2) Heater assemblies are provided with integral fusing for protection of internal heater circuits not exceeding 48 amps each. Auto reset thermo limit controls, magnetic heater contactors (24 v coil) and terminal block all mounted in electric heater control box (minimum 18 ga galvanized steel) attached to end of heater assembly.



