

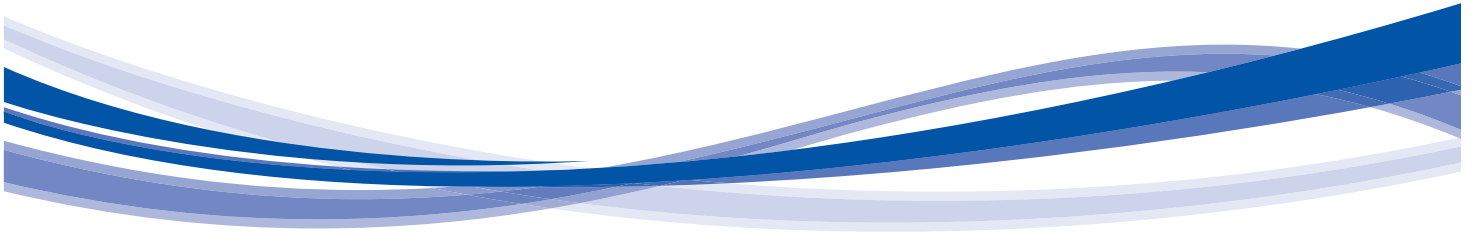

Product Data

Aero[®] Indoor and Weathertight Outdoor Air Handlers

1,500 to 60,500 Nominal cfm



39MN,MW 03-110 Indoor and Weathertight Outdoor Air Handlers

Carrier's 39M air handlers offer:

- Available ECM direct drive fans and fan arrays in a fan airway length as short as 18 inches
- Shrink-wrapped units for complete protection while in transit
- Multiple aspect ratios to choose from to fit spaces short and wide or tall and narrow.
- Factory-supplied variable frequency drives that are programmed and started up at the factory
- Sealed panel double-wall R-13 insulation system
- Stacked indoor unit configurations for application versatility and maximum space utilization
- Outdoor weathertight cabinets have sloped roofs to reduce standing water, and are gasketed in all critical areas.
- Factory installed thermostatic expansion valves (TXV) and nozzles simplifies refrigerant piping installation.
- Factory-installed integral face and bypass coils for extreme conditions
- Factory-installed humidifiers for precise indoor climate conditioning
- Factory-installed indirect fired gas heating sections with a minimum 10:1 turndown
- Factory-installed, AHRI 1060 certified ERV wheel sections
- Available factory-mounted controls, starters, disconnects and variable frequency drives
- **AHUBuilder**[®] software for easy unit selection
- Optional prepainted unit exterior
- Optional Agion¹ anti-microbial coated panel interior
- Optional 304 stainless steel panel interior
- Optional 3003-H14 aluminum panel interior
- Optional factory-installed UV-C germicidal lamps
- Optional factory-installed Test Port
- Factory-installed, sound attenuators

Easy installation

Frames, corners and base rails of the 39M air handler are all easily disassembled and reassembled in minutes with as little as 3 standard tools. Carrier's 39M units can be ordered with shipping splits, which speed section to section assembly.

1. Third-party trademarks and logos are the property of their respective owners.

Redefining flexibility

Standard stacked fans and exhaust box sections reduce the footprint of the unit and ensure economical use of building space. Accessibility is required from only one side of the unit, increasing location options. This may result in floor space savings of 20% over competitive units.

The use of non-staggered coils allows flat and cartridge style filter sections to maintain face velocities of 500 fpm or less at nominal airflow. Low velocity angle filtration sections typically have velocities of 350 fpm or less.

Custom engineered for durability and longevity

Sealed panel double-wall R-13 insulation system means no insulation is exposed to the airstream. All panels are easily removed in one piece for cleaning or access to all components. Hinged doors are also available.

Internally mounted motors and drives operate in a clean environment, giving longer life to motor and belts. Belts and drives are factory installed and aligned.

Factory installed and wired variable frequency drives, bypasses, motor starters and disconnects are easily available at the click of a button with **AHUBuilder**[®] software.

All outdoor 39MW units sized 21 and above are rain tested under design static pressure to assure that the units are water tight from the factory.

Internal isolation of the fan assembly reduces vibration and eliminates the need for unit isolation at installation time. Fan and motor bearings are mounted on a corrosion-resistant steel frame, which is isolated from the outer casing with 2-in. deflection, factory-installed spring isolators and a vibration-absorbent fan discharge seal.

Easy service and maintenance

Panels are easily removed in one piece for cleaning or access to all components. Lockable hinged doors are standard.

Optimized performance

Not only does **AHUBuilder** software help define the footprint of your custom air handler, it also suggests an optimally selected fan based on your performance criteria. Choose from airfoil, forward-curved, direct-drive plenum, and plenum fan arrays based on first cost and performance requirements. As standard, pillow-block bearings are rated at 200,000 hours average life (L₅₀) in all 03-110 size airfoil, forward-curved, and belt-drive plenum fans. Optionally, bearings rated at 500,000 hours average life (L₅₀) are available.

Standard low-leak dampers in mixing box sections seal tightly. Optional high-efficiency airfoil blade dampers are also available.

Exclusive Carrier coil surface results in efficient heat transfer. Since less heating and cooling fluid is circulated, pumping costs are reduced.

Provisions for indoor air quality (IAQ) requirements

Filtration flexibility includes:

- 2-in. or 4-in. flat filters
- 4-in. flat filter with 2-in. prefilters
- 2-in. or 4-in. angle filters
- Side loading 12-in. bag/cartridge filters with 2-in. prefilters
- Side loading 30-in. bag/cartridge filters with 2-in. prefilters
- Face loading bag/cartridge filters without prefilters
- HEPA face loading bag/cartridge filters without prefilters

In addition, filter kits can be ordered with each air-handling unit and will arrive in sealed containers for the unit they are associated with marked on the outside of the box.

Differential pressure gauges are available factory installed and recessed into the filter section door for a clean look and leak tight fit.

Table of contents

	Page
Features/Benefits	2
AHRI Certification	6
Model Number Nomenclature	6
Application Data	7
Selection Procedure	19
Dimensions	21
Physical Data	53
Guide Specifications	116

Optional galvanized or stainless steel coil drain pan

Drain pan is sloped toward the drain to remove condensate completely. This eliminates build-up of stagnant water during shutdown periods and keeps the air handler free of odors and bacteria. Stainless steel provides an easy-to-clean surface that resists corrosion.

UV-C germicidal lamps

- **Energy Savings:** Lowers energy costs by improving HVAC system heat transfer and increasing net cooling capacity.
- **Maintenance Savings:** Continuously cleans coils, drain pans, plenums, and ducts, reducing or eliminating manual cleaning and the use of harmful chemicals.
- **Improved IAQ:** Reduces the spread of airborne microorganisms that trigger allergy and asthma symptoms and reduces the spread of bacteria and viruses that can cause infectious diseases.
- **Water Conservation:** Reclaiming clean condensate for tower makeup, irrigation or gray water flushing reduces water and waste water costs.
- **Rapid Return on Investment:** Offers a return on investment in less than 2 years.
- **LEED¹ Rating System Contribution:** UV-C lamp may contribute to points in one or more areas of the U.S. Green Building Council's LEED rating system.

Extensive AHUBuilder software optimized coil selection

The 39M air handlers have a wide selection of coils to meet your application needs. All 39M coils have Carrier's high-performance coil surface; the coil tubes are mechanically expanded into the fins for improved fin bonding and peak thermal transfer. All vent and drain connections are accessible from outside the cabinet. Optional copper fins and stainless steel casings are available for all coils.

Chilled water coils

These coils have headers precisely sized to minimize water pressure loss. Chilled water coils are manufactured of 1/2-in. OD (5/8-in. OD optional) copper tubes

with aluminum plate fins (8 to 14 fins per in.). Copper and e-coated fins are optional. Large, medium and bypass face area coils are available in 4, 6, 8, or 10 rows. Steel coil connectors with male pipe thread are standard.

Direct expansion coils

There is no need to guess when it comes to direct expansion coil performance. **AHUBuilder[®]** is the only selection program that crossplots the evaporator and condensing unit performance. Coils are available in large or medium face area, with 4, 6, or 8 rows. The tubes are of 1/2-in. OD copper with aluminum-plate fins, and 8 to 14 fins per inch. Factory-installed TXVs and nozzles are available and piped to the cabinet exterior with suction and liquid connections located sided by side. Copper and e-coated fins are available as an option. Choose from quarter, half, full, or double circuits. Most direct expansion coils have at least two splits allowing you to match a coil with one or two condensing units for independent refrigerant systems.

Hot water coils

Carrier's hot water coils are designed to provide heating capability for a complete range of applications, at a working pressure of 300 psig at 200°F. Hot water coils are offered in 1, 2 or 4 rows, with fin spacings of 8 to 14 fins per inch. Coils have aluminum plate fins with 1/2-in. OD (5/8-in. OD optional) copper tubes (copper and e-coat fins available). Hot water coils are available with large, medium, small or bypass face areas.

Steam coils

The 39M inner distributing tube (IDT) steam coils are designed for a working pressure of 175 psig at 400°F. The plate-fin steam coil is available in one row 1-in. OD copper tubes, with 6, 9, or 12 aluminum fins per inch. Steam coils are available with large, medium, small or bypass face areas, and are sloped to drain condensate. Steam coils are especially suited to applications where sub-freezing air enters the air-handling unit, or where uniformity of leaving-air temperature is required.

Integral face and bypass coil section

Carrier offers integral face and bypass (IFB) coils capable of maintaining a constant air volume within 5%, constant leaving-air temperature as entering-air

conditions vary, and mixing of leaving-air temperatures within 3ft downstream with a maximum variance in air temperature of 5°F, regardless of damper position.

Electric heat coil

The 39M electric heat coils may be ordered for factory installation into the electric heat section. Units with electric heat are designed in accordance by UL (Underwriters Laboratories) 60335-2-40.

Indirect fired gas heating

Gas-fired heating sections are available in 409 and 304L stainless steel tubular construction for use with natural gas or propane. Our gas-fired heating sections allow a minimum of 10:1 and up to a maximum of 60:1 electronic modulation depending on unit size and gas heat configuration.

Components for customizing standard units

Humidifiers

The 39M humidifiers use insulated direct steam discharge uprights constructed of 316 stainless steel, supported by horizontal manifolds of the same material. Steam can be delivered to the humidifier at atmospheric pressure from a steam generator or up to 60 psi plant steam.

Face and bypass components with bypass cooling and heating coils

Four different component combinations provide controlled mixing of bypass air and conditioned air. These include bypass heating, bypass cooling, bypass heating/cooling, and bypass cooling/heating in either internal or external bypass mode.

Blow-thru coil

These components are available for single-duct, dual-duct, and multizone applications requiring cooling only or both heating and cooling. The diffuser plate is integrally mounted to the fan discharge in blow-thru applications.

Optional air mixer

When installed immediately downstream from a mixing box or filter mixing box, the air mixer section blends airstreams with different temperatures to within a range of 6°F. The mixer section reduces air stratification and ensures that exiting blended air has a uniform velocity. Blended air helps to reduce the possibility of coil freeze-up and equalizes coil discharge temperatures.

1. Third-party trademarks and logos are the property of their respective owners.

Carrier factory-installed Direct Digital Controls

Carrier offers a wide range of Direct Digital Controls (DDC) to meet your application needs. Contact your Carrier sales representative for details.

Custom design flexibility

Options not shown in the Product Data or **AHUBuilder®** software may be available through the factory design enhancement center. Contact your local Carrier sales representative for details.

Sound attenuator

These components are available in two lengths providing sound reduction at the acoustical performance of the unit.

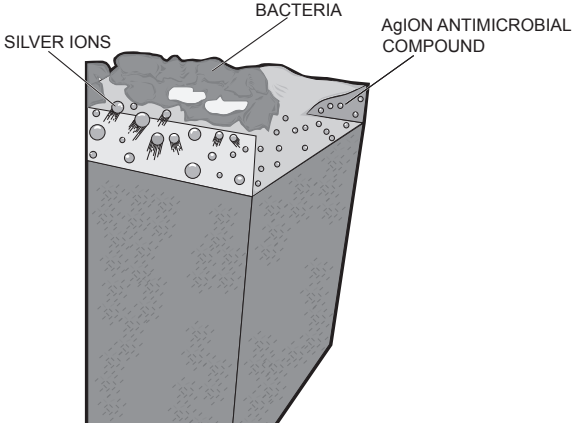

The diagram shows a cross-section of a material with a porous surface. Labels include: SILVER IONS (small circles), BACTERIA (rod-like shapes), and AgION ANTIMICROBIAL COMPOUND (small circles within the pores). Arrows indicate the release of silver ions from the pores towards the bacteria on the surface.

Agion Anti-Microbial Coating

How it works:
The Agion antimicrobial compound is blended into a paint system, which resides in zeolite's open molecular structure. When ambient moisture is present, the zeolite acts as an "ion pump," slowly releasing silver ions. When the silver ions come into contact with bacteria and other microbes, their chemical interaction disrupts electron transfer and respiration, suppressing microbe growth on the air handler. As the air becomes more humid (and the more favorable for microbial growth), more silver is released. However, there is a maximum release rate, so even under very wet conditions, the silver ions are released slowly, for long-term protection of the equipment.

- **Robust casing:** 2 in. post and panelized construction allows panel to be removed while maintaining structural integrity.
- **Rigid design:** Panel construction maintains an industry leading linear deflection ratio of L/240 at ± 8 in. wg.
- **Antimicrobial growth prevention:** Since 2003, Carrier has offered an optional Agion panel coating that provides constant protection against antimicrobial growth on the panels of the air handler with the continuous release of silver ions.
- **Service and access:** Weld-free design promotes panel removal and optimizes serviceability of the unit.
- **Sound performance:** Sound data for fan inlet, discharge, and casing tested and certified in compliance with AHRI 260 and AMCA 300 at design and part load conditions where applicable.
- **Factory-mounted and tested control offerring:** For convenience, available single point power.



- 1 Filtration flexibility:** Expanded filter and filter rack offerings designed to meet ASHRAE 52.1 standards.
- 2 Expanded coil options:** Engineered solutions for coil face area variation ranging from small to large coil offering to meet cost and capacity requirements.
- 3 Condensate control:** Minimum 2 in. thick, R-13 insulated drain pan as standard in all cooling coil selections. Optional drain pans available in other sections.
- 4 Airflow measurement options:** Options such as piezometer rings and AMS dampers measure airflow for more precise unit control.
- 5 Corrosion Prevention:** Electrofin¹ e-coated option offered on coil selections.

NOTE(S):

1. Third-party trademarks and logos are the property of their respective owners.

AHRI certification



The Air-Conditioning, Heating, and Refrigeration Institute (AHRI) is a voluntary, nonprofit organization comprised of the manufacturers of air conditioning, refrigeration, and heating products. More than 90% of the air conditioning and refrigeration machinery and components manufactured in the United States is produced by members of AHRI.

Carrier 39M air handler supply fans are rated and certified in accordance with AHRI Standard 430, which is the industry standard for central station air-handling units. Certification by participating manufacturers of units within the scope of this program requires that the ratings and performance of any central station unit certified to AHRI be established in accordance with the AHRI Standard.

Electric heating coil ratings are not within the scope of the AHRI Central Station Air Handlers Certification program.

All coils installed in the Carrier 39M air handlers are rated in accordance with AHRI Standard 410. Chilled water, hot water, and steam coil performance is certified in accordance with AHRI Standard 410.



Model number nomenclature

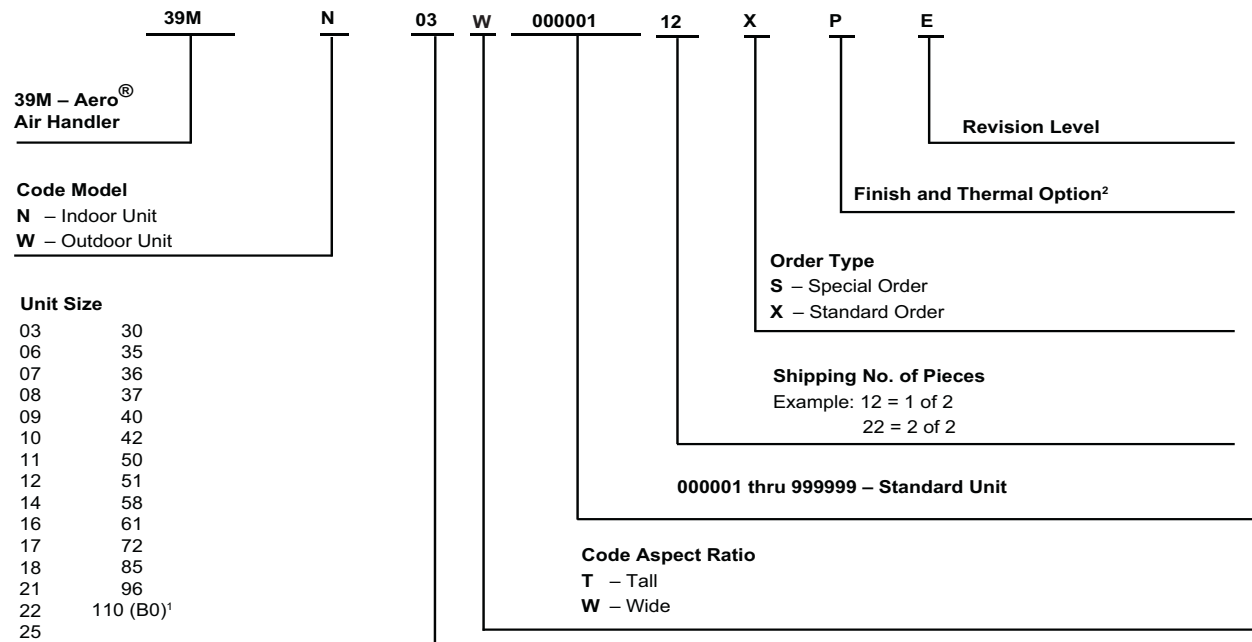

NOTE(S):

- B0 should be used to select unit size 110.
- See Finish and Thermal Option table.

Finish and Thermal Option (Position 17)

CODE	EXTERNAL FINISH	INTERNAL FINISH	THERMAL BREAK
B	Pre-Paint	Agion	Level 1
C	Pre-Paint	Galvanized	Level 2
D	Pre-Paint	Galvanized	Level 1
F	Galvanized	Galvanized	Level 2
G	Galvanized	Galvanized	Level 1
H	Galvanized	Agion	Level 2
K	Galvanized	Agion	Level 1
L	Galvanized	Stainless Steel	Level 2
M	Galvanized	Stainless Steel	Level 1
P	Pre-Paint	Agion	Level 2
R	Pre-Paint	Stainless Steel	Level 2
S	Pre-Paint	Stainless Steel	Level 1
T	Pre-Paint	Aluminum	Level 2
U	Pre-Paint	Aluminum	Level 1
V	Galvanized	Aluminum	Level 2
X	Special Order		

Quality Assurance

ISO 9001:2015-certified processes

MEA (Materials and Equipment Acceptance) number: 92-02-E



Central station air handler

The central station air handler is a heating, ventilating, or air-conditioning unit that is centrally located in, or on, a building or structure. The air handler distributes air to desired areas through a system of ducts.

The 39M factory packaged unit

Individual components, such as fans, coils, and filters, are assembled at the factory.

Packaged equipment is less costly than field-fabricated equipment and does not require assembly.

The basic air-handling unit consists of a fan section and a coil section. Other components, such as filter sections, air-mixing boxes, access sections, and damper sections, may also be provided.

Central station configurations

Draw-thru units

Horizontal

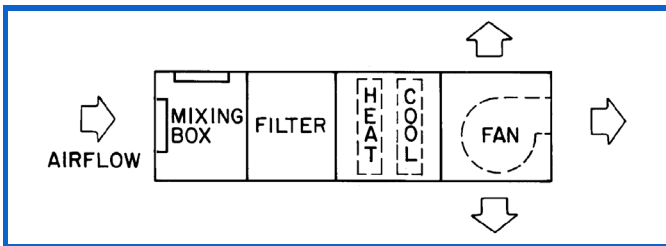

Vertical (indoor unit only)

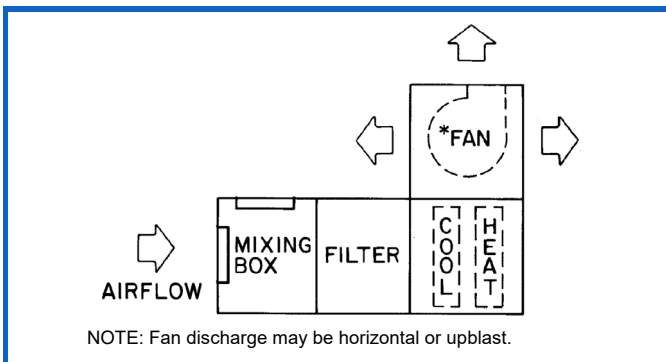

Stacked return fan

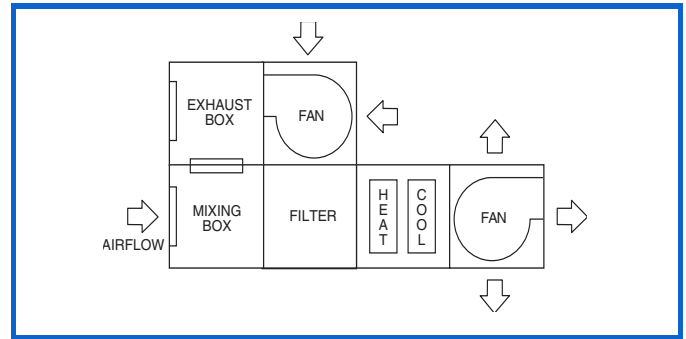

Face and bypass units

Horizontal

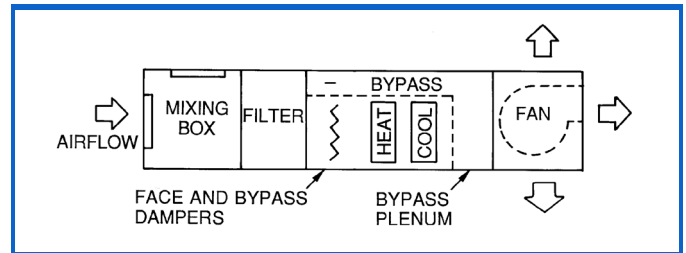

Blow-thru units

Blow-thru arrangements are more suitable on systems with a significant amount of fan (and motor) heat. Fan heat can add 0.3°F to 0.5°F per in. of total static pressure to the airstream. Therefore, on such systems, it is more efficient to use a blow-thru arrangement and add the fan heat before the cooling coil. With a draw-thru unit, the airstream must be subcooled to anticipate the addition of fan heat downstream of the cooling coil. Thermal storage and cold air distribution systems benefit from blow-thru applications.

Air mixing using a plenum fan

A static air mixer is only effective between 900 and 1100 fpm. Using a blow-thru plenum fan as the air mixing device assures proper mixing at all airflows. This arrangement is best for VAV (variable air volume) systems and will eliminate the added expense of a static air mixer.

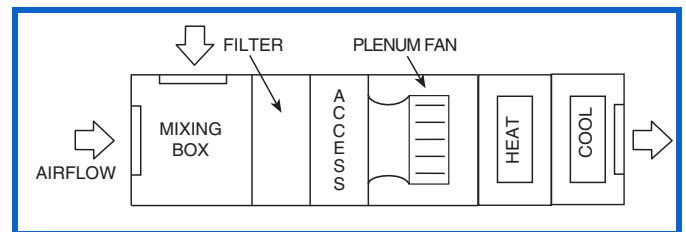

Dual duct

The unit delivers 2 outputs; one outlet produces hot air while the other produces cold air (indoor unit only).

Multizone

Mixing dampers blend hot-deck and cold-deck temperatures to produce a desired temperature for individual zones. Several blending dampers per unit produce independent zones, each responding to its own thermostat (indoor unit only).

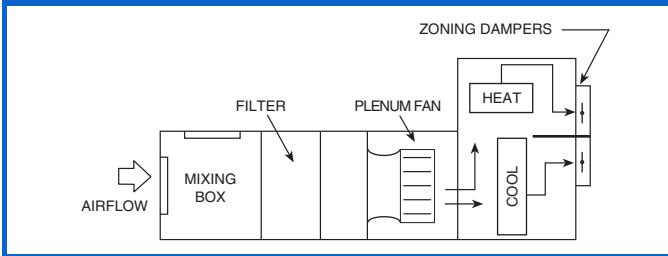

High filtration units

High filtration units employ a filter section ahead of the cooling and heating coils. A second filter section, called a final filter, is placed at the end of the unit at the point where the air enters the ductwork.

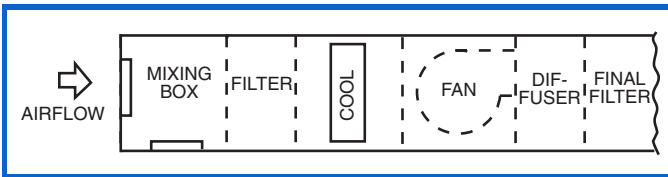

Fans

The 39M central station air handlers use belt-driven and direct-driven centrifugal fans. A centrifugal fan is one in which the air flows radially through the impeller. Centrifugal fans are classified according to fan wheel and blade construction. The 39M fans can be selected as double width, double inlet (DWDI) with forward curved or airfoil blades. Plenum fans are selected as single width, single inlet (SWSI) with airfoil or backward blades. Standard and small wheels are available on most sizes.

Laws of fan performance

Fan laws are used to predict fan performance under changing operating conditions or by fan size. They are applicable to all types of fans.

The fan laws are stated below. The symbols used in the formulas represent the following variables:

CFM — Volume rate of flow through the fan.

RPM — Rotational speed of the impeller.

P — Pressure developed by the fan.

Hp — Horsepower input to the fan.

D — Fan wheel diameter. The fan size number can be used if it is proportional to the wheel diameter.

W — Air density, varying directly as the barometric pressure and inversely as the absolute temperature.

Application of these laws is limited to cases where fans are geometrically similar.

Fan Laws

VARIABLE	CONSTANT	LAW	FORMULA
SPEED (RPM)	Air Density Fan Size Distribution System	Airflow varies directly with the Speed.	$\frac{CFM_1}{CFM_2} = \frac{RPM_1}{RPM_2}$
		Pressure varies as the square of the Speed.	$\frac{P_1}{P_2} = \left(\frac{RPM_1}{RPM_2}\right)^2$
		Horsepower varies as the cube of the Speed.	$\frac{Hp_1}{Hp_2} = \left(\frac{RPM_1}{RPM_2}\right)^3$
FAN SIZE (D)	Air Density Tip Speed	Capacity and Horsepower vary as the square of the Fan Size.	$\frac{CFM_1}{CFM_2} = \frac{Hp_1}{Hp_2} = \left(\frac{D_1}{D_2}\right)^2$
		Speed varies inversely as the Fan Size.	$\frac{RPM_1}{RPM_2} = \frac{D_2}{D_1}$
		Pressure remains constant.	$P_1 = P_2$
	Air Density Wheel Speed	Capacity varies as the cube of the Size.	$\frac{CFM_1}{CFM_2} = \left(\frac{D_1}{D_2}\right)^3$
		Pressure varies as the square of the Size.	$\frac{P_1}{P_2} = \left(\frac{D_1}{D_2}\right)^2$
		Horsepower varies as the fifth power of the Size.	$\frac{Hp_1}{Hp_2} = \left(\frac{D_1}{D_2}\right)^5$
AIR DENSITY (W)	Pressure Fan Size Distribution System	Speed, Capacity, and Horsepower vary inversely as the square root of Density.	$\frac{RPM_1}{RPM_2} = \frac{CFM_1}{CFM_2} = \frac{Hp_1}{Hp_2} = \left(\frac{W_2}{W_1}\right)^{1/2}$
	Airflow Fan Size Distribution System	Pressure and Horsepower vary with Density.	$\frac{P_1}{P_2} = \frac{Hp_1}{Hp_2} = \frac{W_1}{W_2}$
		Speed remains constant.	$RPM_1 = RPM_2$

Fan selection criteria

System requirements

The major factors that influence fan selection are airflow, external static pressure, fan speed, brake horsepower, and sound level. Additional system considerations include the fan control method, overloading, redundancy, and non-standard air density. Fan selection for air-conditioning service usually involves choosing the smallest fan that provides an acceptable level of performance, efficiency and quality.

Pressure considerations

The static pressure is the resistance of the combined system apart from the fan. Contributors to static pressure include other components in the air handler, ductwork, and terminals. The static pressure is dependent on the airflow through the system, which is determined by the air conditioning requirements. As shown in the second fan law in the table on the preceding page, the static pressure varies as the square of the airflow (cfm). This ratio between pressure and airflow determines the system curve for any air-handling system.

The static pressure used to select a fan should be the pressure calculated for the system at design airflow. If the static pressure is overestimated, the increase in horsepower and air volume depends upon the steepness of the fan curves in the selection area.

With forward-curved (FC) fans, if the actual system static pressure is less than the design static pressure, the fan has a tendency to deliver more air and draw correspondingly higher bhp (kW of energy). This higher current draw may overload the motor and trip circuit breakers. This is a common occurrence when FC centrifugal fans are operated before all the ductwork has been installed, or during the pull-down load on a VAV system.

With airfoil (AF) fans (non-overloading), if the actual static pressure is less than the design static pressure, the fan delivers more air with little or no increase in bhp in most applications. In this case, adding a safety factor to the calculated static pressure can increase fan horsepower (and costs) unnecessarily.

Stability

Fan operation is stable if it remains unchanged after a slight temporary disturbance, or if the fan operation point shifts to another location on the fan curve after a slight permanent disturbance. Fan operation is unstable if it fluctuates repeatedly or erratically. There are 2 main types of unstable fan operation:

System surge is a cycling increase and decrease in system static pressure.

Fan stall is the most common type of instability, and it occurs with any type of centrifugal fan when the fan is starved for air.

Normally, the rotation of the fan wheel forces the air through the blade passageway from the low pressure to the high pressure side of the fan. If the airflow is restricted too much, however, there is not enough air to fill the space between the blades and the air distribution between the blades becomes uneven and erratic. Air can flow backwards through the wheel, substantially increasing the noise level. If the fan runs in this condition for a long time, wheel failure will likely occur.

For a given speed, the operating point where a fan stalls is a function of the wheel geometry and wheel speed. In

general, the stall point is within 15 to 25% of the airflow obtained at free delivery.

Stability and VAV applications

Special considerations must be made for VAV systems. While the initial fan selection may be acceptable, its operating point could shift to a point of stall at minimum airflow and pressure conditions. The typical minimum airflow is half of the design cooling airflow, which is also often equal to the heating airflow. To determine and plot the minimum airflow versus static pressure, use the following equation. This equation solves for the static pressure at a specific airflow based on a minimum static pressure set point:

$$\left(\left(\frac{CFM_1}{CFM_{DESIGN}} \right)^2 \times (SP_{DESIGN} - SP_{MIN}) \right) + SP_{MIN} = SP_1$$

$$\left(\left(\frac{7,500}{15,000} \right)^2 \times (4 - 2) \right) + 2 = 2.50 \text{ IN. WG}$$

CFM — Airflow in Cubic Feet Per Minute
SP — Static Pressure

The table below illustrates a system with an airfoil fan wheel at a cooling design of 15,000 cfm and a system static pressure of 4 in. wg. The minimum airflow is 7,500 cfm with a minimum system static pressure set point of 2 in. wg. **The minimum static set point is based on zero airflow and does not coincide with the minimum design airflow.**

Example:

% CFM	CFM	SYSTEM AND FAN STATIC PRESSURE in. wg
100	15,000	4.00
90	13,500	3.62
80	12,000	3.28
70	10,500	2.98
60	9,000	2.72
50	7,500	2.50

As shown on the highlighted VAV curve, the minimum airflow and static pressure (MP) are both well within the fan's acceptable operating conditions.

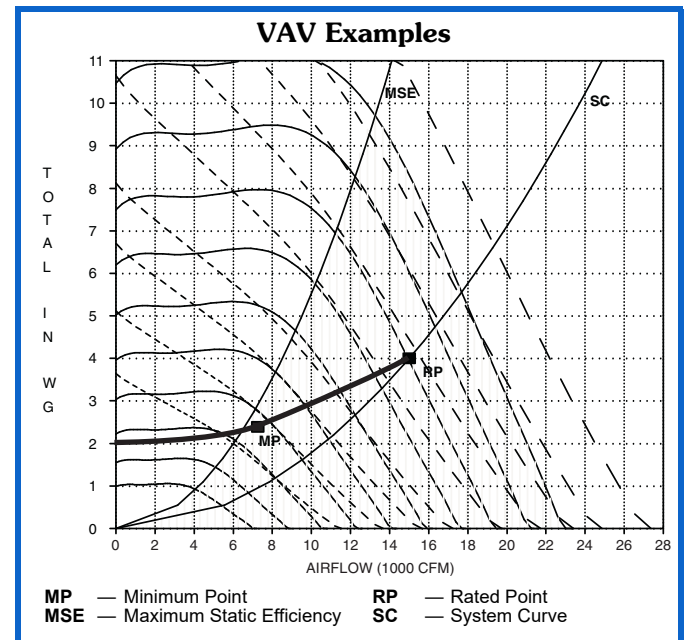

Sound considerations

The fan is one of the main sound sources in an air-conditioning system. Other sources of sound include the duct system and terminals, because they generate turbulence in the air flowing through them. Simply estimating fan sound does not give an accurate picture of total system sound, but fan sound is a major component of system sound, and should be minimized.

To minimize its sound generation, a fan must be correctly sized and selected to operate at or near peak efficiency. Oversized fans can generate much higher sound power levels than necessary, especially in VAV systems operating at low airflows. Undersized fans can also result in higher sound power levels because of increased fan speeds and the higher tip velocity of the air leaving the fan blades.

For VAV systems, the part load point at which the fan operates most of the time should be used to select a fan for lowest sound output.

Variable frequency drives (VFDs) are used to modulate fan volume. A VFD reduces the sound power level as the fan speed is reduced. At 50% load, the sound level is reduced approximately 15 dB compared to the sound level at 100% load. When using variable frequency drives, it is important that the static deflection of the vibration isolators is adequate. At very low fan speeds, the fan frequency may approach the natural frequency of the spring isolation. If this happens, the vibration levels can be amplified and resonant vibration conditions can occur.

When sound level is a major consideration, a blow-thru fan should be considered because of the reduced discharge sound level. This sound reduction is due to the sound absorption of the coil section downstream from the fan. Transition fittings and elbows can be reduced in size or eliminated, thereby eliminating a sound source.

A sound attenuator can be added to the unit configuration to absorb a portion of the generated fan sound power levels.

To obtain projected sound data for a selected 39M unit, use the electronic catalog **AHUBuilder**® program.

Dirty filtration considerations

Consider selecting an air handler with dirty filters so that, in theory, the unit will have enough horsepower to deliver the same amount of air when the filters are dirty. On a constant volume unit, that would only work if the unit contained an airflow measuring station and could adjust the flow accordingly via a VFD. Otherwise, the point of operation moves along the rpm line as the static pressure in the system changes.

What happens when you order the fan with sheaves selected for dirty filters? Three things:

1. The air balancer forces the selection of a smaller sheave because the airflow is too high. When the filters load up, airflow is reduced.
2. If an air balance is not performed, the cooling coil may exhibit moisture carryover due to the considerable increase in airflow.
3. The fan motor trips out on overload with the forward curve fan because of the increase in bhp.

Example:

Forward-Curved Fan, 15,000 cfm, 1010 rpm, 17.8 hp, selected with 100% dirty 60 to 65% cartridge filters and pre-filters. Dirty filters result in a total static pressure (TSP) of 4 inches.

Clean filters result in a TSP of 2.55 inches.

In the following chart, follow the 1010 rpm line down to 2.55 inches.

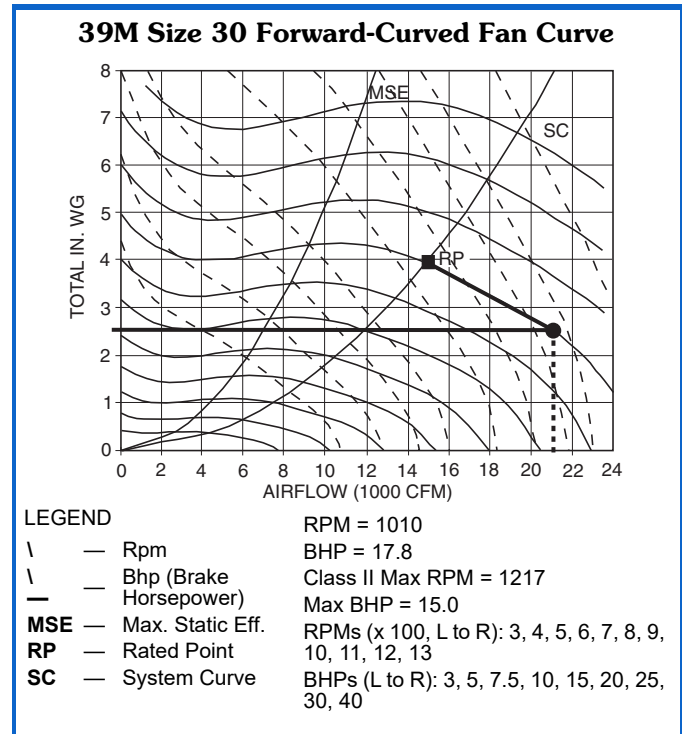

Airflow with a clean filter will be 21,000 cfm. Also note that the horsepower goes from 17.8 bhp to about 28 bhp because the FC fan is an overloading type fan.

So, if dirty filters need to be taken into consideration, do one of the following:

1. Make the final fan selection with the **clean** filter rpm but use the motor horsepower requirement for **dirty** filters.
2. Make the final fan selection with the **dirty** filter rpm and use the motor horsepower requirement for **dirty** filters – **only if** the engineer plans on using a VFD and airflow measurement station or if it is a VAV system.
3. Use an airfoil fan when the difference between dirty and clean filter pressure drop is greater than 1 inch. That way, the difference between clean and dirty airflow is minimized.

Example:

Airfoil Fan, 15,000 cfm, 2210 rpm, 18.8 hp, selected with 100% dirty 60 to 65% cartridge filters and pre-filters. Dirty filters result in a total static pressure (TSP) of 4 inches.

Clean filters result in a TSP of 2.55 inches.

In the following chart, follow the 2210 rpm line down to 2.55 inches.

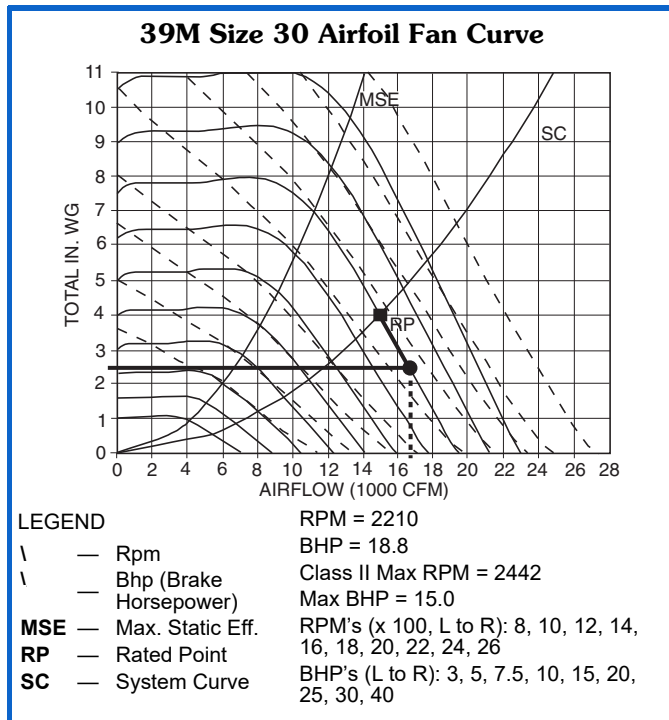

Airflow with a clean filter will be 16,700 cfm. Since airfoil fans are non-overloading (bhp lines run parallel with rpm lines) the bhp does not change (actually, bhp decreases).

Fan, motor, and drive heat considerations

The work output of a fan and its motor and drive contribute directly to the airflow and pressure exiting the air handler. Not all of the fan energy output generates airflow, however. Fan motors are not 100% efficient, and their efficiency loss translates directly into heat that must be factored in when calculating the temperature rise across a fan section. Fans also add a certain amount of heat to the airstream due to the effects of compression and bearing friction. Finally, belt drives do not transmit all of the energy generated by the motor. Some of the energy is lost as heat due to belt tension and the type and number of belts. Belt drive bhp losses range from 2 to 6 percent; a 3% loss is typical.

Because the 39M Series air handlers all have fans, motors, and drives located within the airstream, heat losses from these components affect the power requirements, cooling load, and heating load.

Power losses in the motor and drive should be allowed for when determining the motor output (bhp), so that the motor can be correctly sized and the additional heat output can be subtracted from cooling capacity or added to heating capacity. A typical example follows:

Given Fan Operating Point:

- 13,224 cfm
- 9.6 Fan bhp
- 3.0% Estimated drive loss

Calculate the required fan motor output (H_p) due to drive loss.

$$H_p = (\text{Fan bhp}) \times (\text{Drive Loss})$$

$$H_p = 9.6 \times 1.03$$

$$H_p = 9.89 \text{ hp (select 10 Hp motor)}$$

Calculate the total fan motor heat output (Q) according to motor efficiency:

$$Q = (\text{Motor Output}) \div (\text{Motor Efficiency [Typical]})$$

$$Q = 9.89 \div 0.86$$

$$Q = 11.5 \text{ hp}$$

Convert horsepower to Btu per hour.

$$11.5 \text{ hp} \times 2545 = 29,268 \text{ Btuh}$$

Calculate the increase in leaving-air temperature (ΔT) due to fan and motor heat and drive losses:

$$Q = 1.1 \times \text{cfm} \times \Delta T$$

$$29,268 \text{ Btuh} = 1.1 \times 13,224 \times \Delta T$$

$$29,268 \text{ Btuh} = 14,546.4 \times \Delta T$$

$$\Delta T = 2.01 \text{ F (use to estimate coil requirements)}$$

Fan application

Certain fans are more efficient in low static pressure systems, while others operate best in higher pressure systems. Some fan types are designed to handle very large air volumes while others are more efficient at lower volumes. See the Fan Type and Application table on page 12.

Forward-curved (FC) fans are typically used for low to medium pressure applications (0 to 5 in. wg total static pressure [TSP]).

The FC fans are reasonably stable over a wide airflow (cfm) range at constant speed. Because of the relatively flat curve, FC fans tolerate modulation in airflow without large increases in static pressure. Most important, FC fans have the lowest first cost.

Airfoil (AF) fans are most efficient at higher static pressures (4.0 to 8.0 in. wg total static pressure).

Because of the shape of the AF fan performance curve, bhp decreases as air volume decreases only when a VAV volume control device, such as a variable frequency drive (VFD), is used.

Airfoil fans are more expensive than FC fans and, in addition, there is a price premium for the volume control device, if required.

Plenum fans (sometimes called “plug” fans) are typically used in medium to high static pressure applications where ductwork requires discharge location flexibility. They can reduce the need for ductwork turns or diffusers, especially when equipment room space is limited.

Plenum fans are less efficient than double-width, double-inlet airfoil fans. General construction also differs from that of FC or AF fans. The fan does not have a scroll to enclose the fan wheel and direct airflow. Instead, the entire interior of the plenum fan section is pressurized by the fan.

Plenum fans have single-width, single-inlet (SWSI) construction. The fan shaft is parallel with the airflow, and the motor and bearings are located inside the plenum in the pressurized airstream. An optional inlet screen and wheel cage [belted plenum fans and direct fans (single or dual only) with NEMA motors] can be installed to help protect personnel during maintenance.

Plenum fans are generally used where there are space limitations, a need for discharge flexibility, a need for reduced discharge sound, or where duct configurations might change in the future. For example, in an application where there is not enough room in the building for a large main duct, several smaller duct runs may approach the mechanical equipment room from all sides. In such an application, several connections can be made to one or more sides of the plenum fan section. Installing contractors can cut

outlets in the plenum box at the time of installation to suit the conditions at the jobsite.

Because the casing of a plenum fan section acts as a sound attenuator, plenum fans are sometimes used when discharge sound levels need to be reduced.

Duct takeoffs from plenum fans can have relatively high pressure losses and can also create turbulence that causes a larger pressure drop across coil and filter sections. When selecting a plenum fan, the pressure drop for the duct takeoffs must be added to the external static pressure for the rest of the system.

To calculate the pressure losses from plenum fan duct takeoffs, use the following formula and refer to the figure at right.

$$P_l = P_p - P_d = (C_v) (V_p)$$

Where P_l is the pressure loss, P_p is the plenum pressure, P_d is the duct pressure, C_v is the pressure loss coefficient, and V_p is the velocity pressure in the duct. Note that for radial duct takeoffs, C_v is 1.5 in. wg, while for axial duct takeoffs, C_v is 2.0 in. wg. To calculate velocity pressure (V_p) in the duct, use the following formula, where V is the air velocity in the duct:

$$V_p = [(V) \div (4005)]^2$$

Also note that with more than one duct takeoff and different duct velocities, the highest duct velocity and highest C_v value should be used in the formulas.

Duct design considerations (system effect prevention)

The discharge ductwork immediately downstream from the fan is critical for successful applications. Poorly designed ductwork can degrade fan performance and contribute to excessive pressure drop and noise.

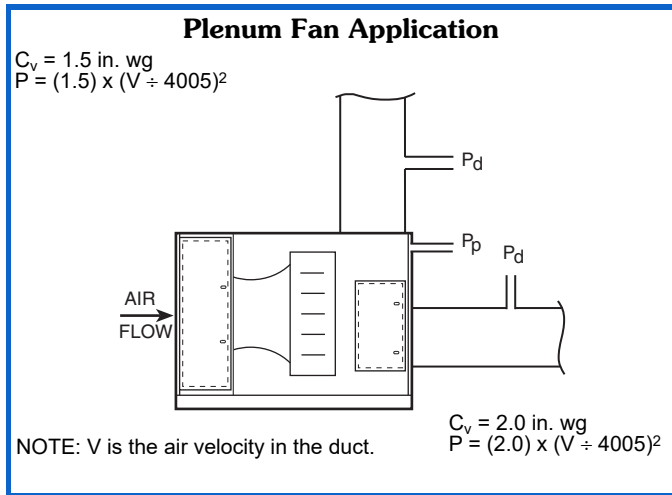

The 39M Series airfoil and forward-curved fans are tested as part of a system with straight discharge ductwork, and the fan ratings are based on this duct design. When designing ductwork in the field, it is important to use a straight discharge duct of the correct dimensions to obtain maximum fan performance. Straight ductwork helps the airflow to develop a uniform velocity profile as it exits the fan and allows the velocity pressure to recover into static pressure. See the figure below.



For 100% recovery of velocity pressure into static pressure, the straight portion of the discharge duct must be at least 2-1/2 times the discharge diameter in length for velocities of 2500 fpm or less. For each additional 1000 fpm, add one duct diameter to the length of the straight portion of the ductwork.

As an example of how to size the straight portion of duct, assume the fan has a 34 x 34 in. discharge outlet (8.03 sq ft). The equivalent diameter is 39 in., so the straight duct length required would be 8 ft long.

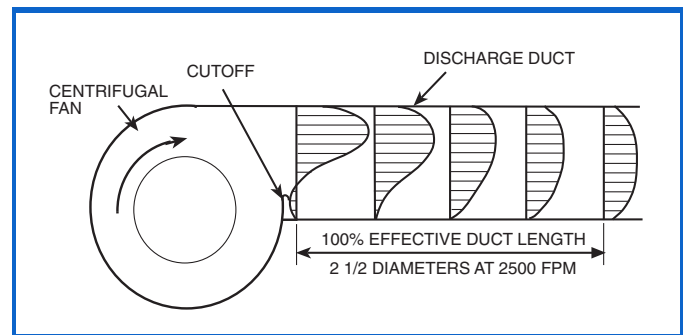
Plenum fans do not require straight ductwork of a particular minimum length, because velocity pressure is converted to static pressure inside the plenum fan section. Outlet ducts, however, should not be installed directly in line with the air discharge from the fan wheel.

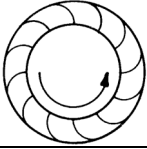

Fan Type and Application

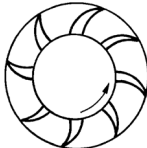
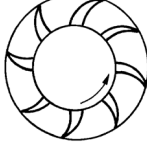
TYPE	CHARACTERISTICS	APPLICATION
FORWARD-CURVED (FC) SIDE VIEW 	<ul style="list-style-type: none"> • Double-width, double-inlet (DWDI) construction. • Best at low or medium pressure (approximately 0 to 5 in. wg). • Horsepower increases continuously with increase in air quantity (overloads) as static pressure decreases. • Less expensive than AF fans. • Runs at relatively low speed, typically 400 to 1200 rpm. • Blades curve toward direction of rotation. 	For low to medium pressure air-handling applications.
AIRFOIL (AF) SIDE VIEW 	<ul style="list-style-type: none"> • Double-width, double-inlet (DWDI) construction. • Best in high capacity and high-pressure applications (4 to 8 in. wg). • Horsepower peaks at high capacities. • Most expensive of centrifugal fans. • Operates at high speeds, typically 1200 to 2800 rpm. About double the speed of FC fan for similar air quantity. • Blades have aerodynamic shape similar to airplane wing and are curved away from direction of rotation. 	For medium to high air capacity and pressure applications.
PLENUM, DIRECT DRIVE WITH NEMA MOTORS (PAF) END VIEW 	<ul style="list-style-type: none"> • Single-width, single-inlet (SWSI) construction. • Characteristics similar to DWDI airfoil fan. • Blades have aerodynamic shape similar to airplane wing and are curved away from direction of rotation. Fewer blades and wider blade spacing than AF fans. • Available as belt drive or as direct drive shaft mounted on a NEMA "T" frame. 	Best in applications with limited space or multiple ducts.
PLENUM, DIRECT DRIVE WITH EC MOTORS (PFEC) END VIEW 	<ul style="list-style-type: none"> • Single-width, single-inlet (SWSI) construction mounted to rotor of supplier matched electronically commutated motor. • Blades curve away from direction of rotation. • Various combinations of fan sizes and quantities available for fan efficiency optimization. 	Best in applications with requirements for limited space, high-efficiency or fan redundancy.

Fan control on variable air volume systems

Introduction

Since VAV systems inherently reduce airflow to meet demand, they are a major source of energy savings. This occurs because fan brake horsepower (bhp) varies with the amount of air delivered.

The degree to which bhp savings are realized, however, is also affected by the type of fan volume control selected and the effectiveness of its application. Effective fan control ensures proper duct pressure for the required control stability of the air terminals and provides quiet terminal unit operation when "riding the fan curve."

Consider the following when selecting a fan volume control method:

1. System parameters
 - a. Airflow (cfm)
 - b. Static pressure
 - c. Percent volume reduction (turndown)
2. Fan type and selection point
 - a. Design point efficiency
 - b. Part load efficiency (especially the point where the fan will be operating most of the time)
 - c. Part load stability
3. Ease of control installation and use

4. Motor selection
 - a. Higher bhp inputs due to efficiency of VAV control method
 - b. Compatibility with VAV control
5. Sound levels
 - a. Fan-generated sound
 - b. Terminal sound
 - c. Control-generated sound
 - d. System sound (ducts, fittings)
6. Initial cost and operating cost
7. Reliability and ease of maintenance

System parameters

Before a fan type or control is selected, the system must be analyzed at both the design point and part load. The fan is likely to be operating at part load a large percentage of the time.

Methods of fan air-volume control

- "Riding the fan curve" with terminal throttling (forward curved fans)
- Variable frequency drives (VFDs)
- Electronically commutated motors (ECMs)

A short description of air-volume control methods follows. A summary comparison table is provided at the end of the section.

Forward-curved (FC) fans with terminal throttling (riding fan curve)

This is the simplest, most reliable, and most economical first-cost method of air volume control on VAV systems, since no accessories are required. This type of VAV control can be used on forward-curved fans with flat pressure characteristics and in systems where static pressure changes at the terminals are moderate. Air volume reduction is produced solely by throttling of terminal units in response to load reduction. As the units throttle, system resistance changes.

The chart below, Forward-Curved Fan with Air Terminal Throttling, illustrates the reduction in bhp and airflow at constant speed. Point A is the peak airflow operating point. Note the required bhp at this airflow. As airflow is reduced by terminal throttling, move along the fan constant rpm curve to point B. Note the lower cfm and bhp values at B.

At reduced airflow conditions, the total system static pressure may undergo little or no change, although air pressure loss through the air-handling unit decreases. This means that duct pressure increases as pressure loss across the terminal unit increases. For low-static and medium static pressure systems, this increase in duct pressure should not result in noticeable sound level changes. However, at higher design static pressures, sound levels and duct leakage may increase and the control method should be reviewed to determine if it is feasible.

Variable frequency drives

Variable frequency drives (VFDs) modulate the fan motor speed in response to air volume requirements. To vary the motor speed, a VFD changes the input frequency and line voltage into a wide range of frequency and voltage outputs, while maintaining a constant frequency to voltage ratio.

Variable frequency drives convert input ac power to dc power and then convert the dc power to a different ac power output using an inverter. The inverter creates the ac output by rapidly switching the polarity of the voltage from positive to negative. Power output from the VFD is not a smooth sine wave, but has many "steps" in the wave form. This type of power output can cause a standard fan motor to exceed its rated temperature range. The stepped power output also results in motor efficiency losses that must be considered when calculating the energy savings offered by the VFD.

Due to the stepped power output generated by VFDs, fan motors rated for inverter duty are recommended. If a standard motor is used with a VFD, the motor should not be operated at the full service factor.

Variable frequency drives can be an effective way to control air volume and save energy. At reduced load requirements, fan speed is reduced proportionately with resulting lower airflow, lower static pressure, lower bhp requirements, and lower sound levels.

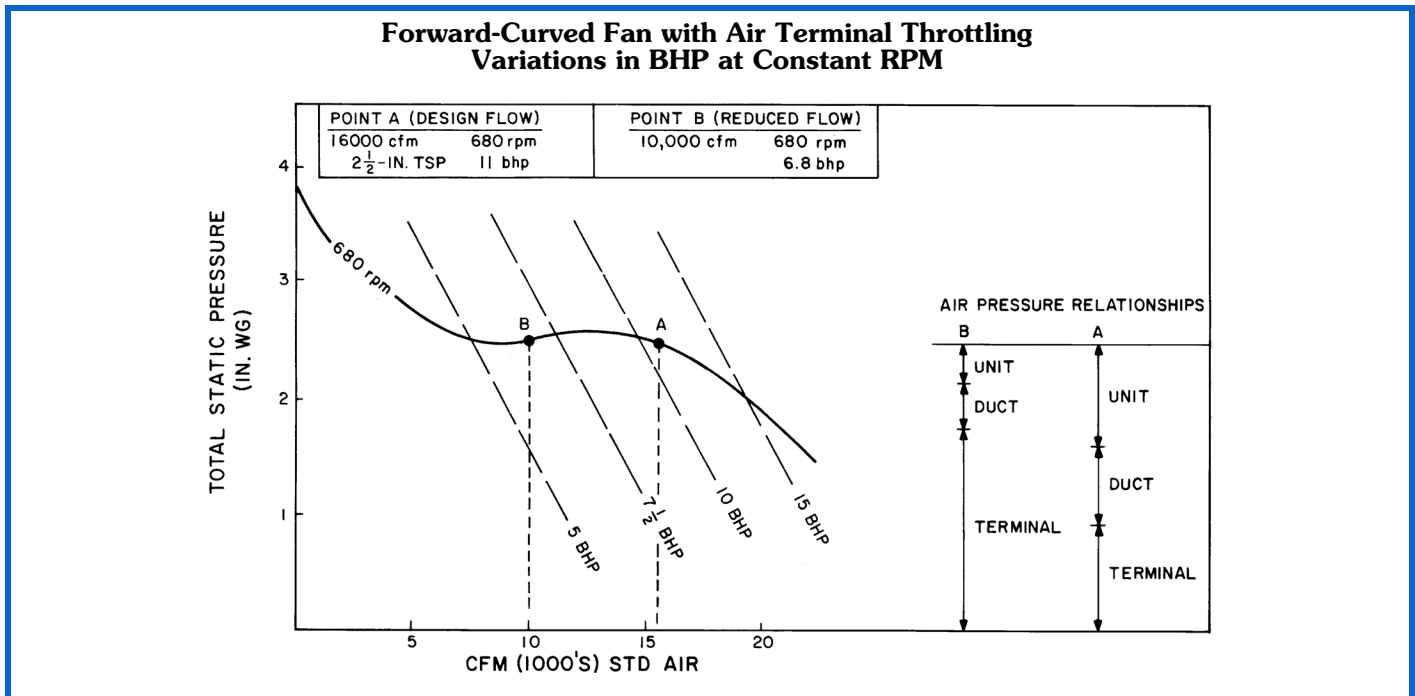

Application data (cont)



As the load decreases in a VAV system and the terminal units throttle, duct static pressure increases. A static pressure sensor in the duct system detects the pressure increase and initiates a fan speed change through the VFD or EC motor. Fan speed is reduced until the duct sensor detects a satisfactory duct pressure.

The Variable Frequency Fan Speed Control chart illustrates the results of fan speed reduction as operation shifts from Point A to Point B. If duct pressure begins to fall due to terminal units opening, the duct sensor signals the VFD or EC motor to increase fan speed.

This method of air volume control permits fan speed reduction down to as low as 10% of the design speed. With FC fans riding the fan curve at the lower rpm, airflow may be as low as 10% of peak design, as long as motor rpm is not less than 1/6 of motor synchronous speed.

The method may be applied to any size VAV system with any type of fan. It is particularly cost effective on systems with high turndown requirements where the full speed reduction capability can be used.

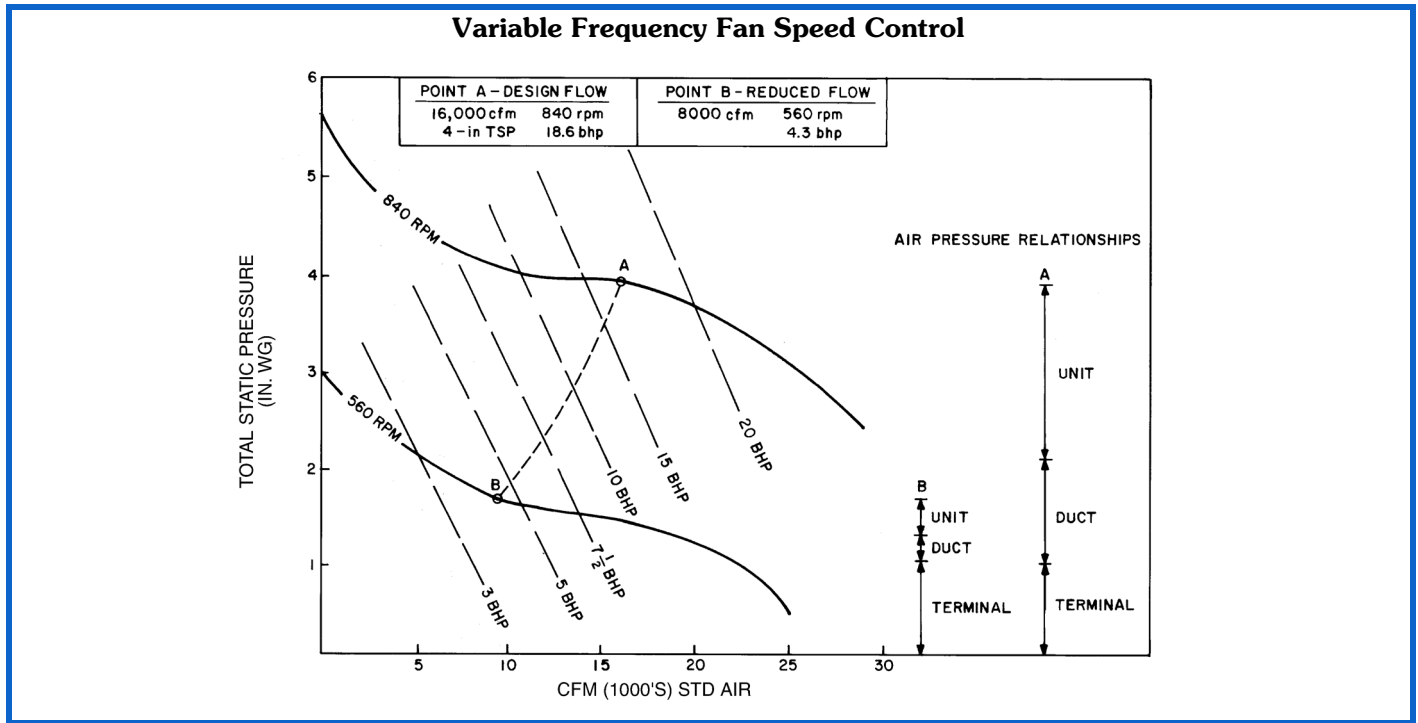

Fan Summary Comparison

TYPE OF CONTROL	FIRST-COST RANK	SOUND GENERATION RANK*	ENERGY-SAVINGS RANK	APPLICATION RANGE — NORMAL FOR AIR COND.	COMMENTS
FC FAN TERMINAL THROTTLING (RIDING FAN CURVE)	1 (Lowest Cost)	4	4	TSP 0 to 4.5 in. wg Cfm 3,000 to 35,000	For moderate turndown systems with a flat fan curve and low to medium static pressure and cfm range.
FC FAN WITH VARIABLE FREQUENCY DRIVE	3	1 (Quietest)	3	TSP 0 to 4.5 in. wg Cfm 3,000 to 35,000	For high turndown, low to medium static pressure systems. Fast payback. Fan generates least sound.
AF AND PLENUM FAN WITH VARIABLE FREQUENCY DRIVE	4	1 (Quietest)	2	TSP 4.5 to 8.0 in. wg Cfm 5,000 to 63,000	For high turndown, medium to high static pressure systems. Fan generates least sound.
PLENUM FAN WITH EC MOTOR	2	2	1 (Best)	TSP 0 to 8 in. wg Cfm 1,000 to 63,000	For high turndown, low to high static pressure systems. Best energy savings.

LEGEND

- AF — Airfoil
- EC — Electronically Commutated
- FC — Forward Curved
- TSP — Total Static Pressure

*Including part load.

NOTE: Rank is based on a relative scale of 1 to 4. Some methods have comparable rating.

Unit control arrangements with Carrier Direct Digital Controls

Supply fan control

In a VAV system, supply fan control is used to match the supply fan delivery to the airflow required by the load. This is done by maintaining a constant static pressure in the supply duct at a point approximately 2/3 of the distance from the supply fan discharge.

The DDC processor uses a control loop to provide the capability. This processor measures the static pressure at the pick-up probe, compares it to the desired set point, and modulates the fan volume control device. See the Supply Fan Control figure. The volume control device can be a factory-installed or field-installed variable frequency drive (VFD) or EC motor.

The VFD or EC motor provides the ability to maintain control over a much larger airflow range (it has a higher turn-down ratio). The following guideline should be used to ensure proper control:

- Variable frequency drives should not be operated at below 1/6 motor synchronous speed.

For supply fan applications, the DDC processor option maintains the duct static pressure at a desired set point between 0.2 and 4.5 in. wg to within ± 0.1 in. wg throughout the fan control range. In applications where more than 100 ft of pneumatic tubing is required, the transducer must be removed from the control box and remotely mounted near the static pressure pickup.

Indoor air quality (IAQ) applications

The CO₂ demand-controlled ventilation (DCV) override increases the minimum ventilation level in order to maintain the CO₂ level at or below the maximum level per person. By ventilating only to the actual rate required, rather than the maximum design occupancy rate, energy savings are achieved. When combined with Product Integrated Controls, this feature automatically adapts and changes ventilation quantity without operator set point adjustments. The CO₂ DCV override feature has user-selectable values for minimum mixed-air temperature override, maximum damper ventilation override position, and supply air tempering (when hot water/steam heat is used).

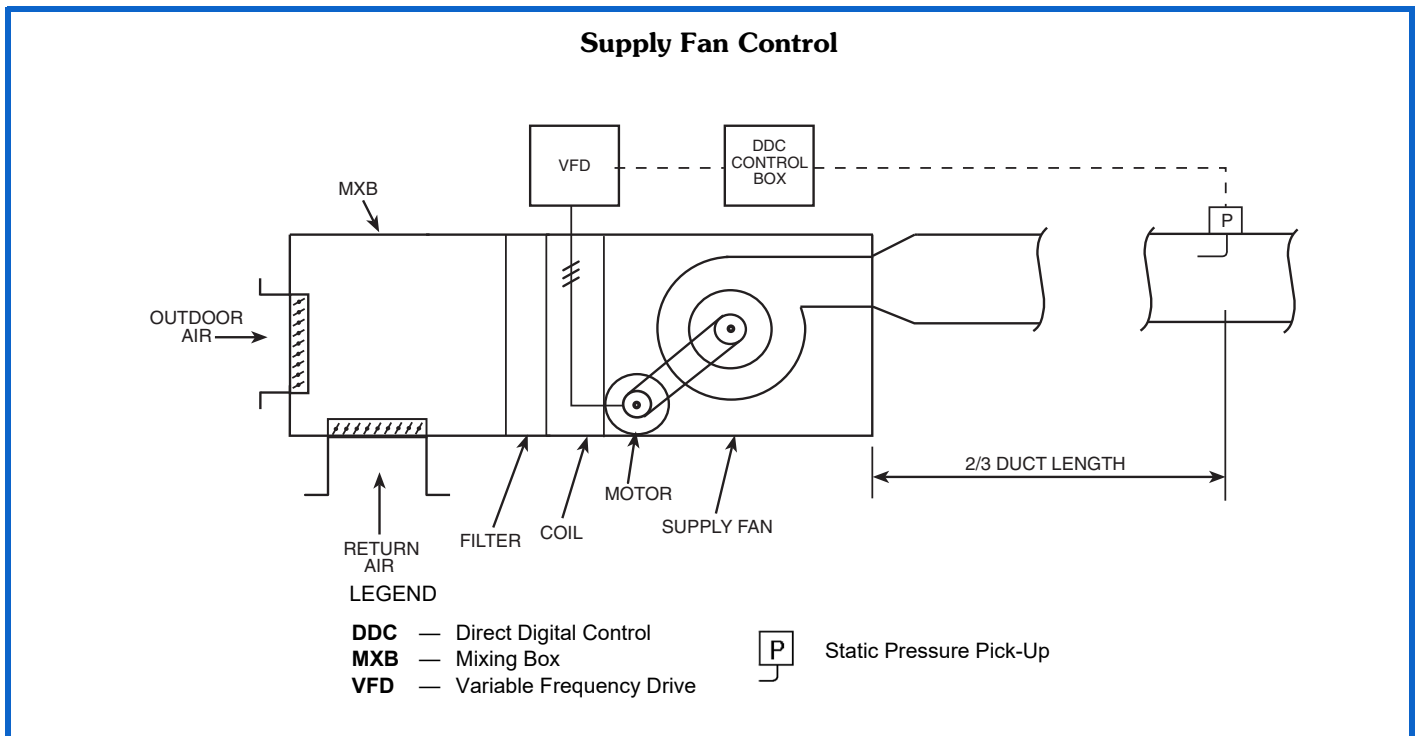

Coils

Coil definitions

A coil, as the term is used with air-handling equipment, is a heat exchange device. A heating or cooling medium passes through the coil, where it either rejects heat to, or absorbs heat from, the airstream passing over the coil, depending upon the relative temperatures of the medium and airstream.

Tube

The tube is a small-diameter pipe through which the heating or cooling medium passes as it rejects or absorbs heat. Coil tubes are generally constructed of copper but may be made of other metals.

Fin

The coil fin is a thin metal plate attached to the tube to improve the heat transfer efficiency from medium to airstream. Typically, it is made of either aluminum or copper.

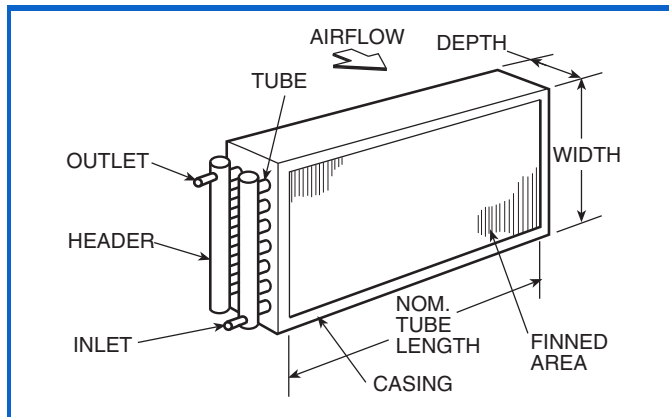

Header

The header is a large diameter pipe to which several tubes are connected. It distributes the heating or cooling medium to the tubes. Headers are typically of non-ferrous metal or steel.

Casing

The supporting metal structure for tubes and header is called a casing. It is usually made of galvanized steel but can be made of other materials (stainless steel).

Inlet and outlet

These are pipe stubs on the header where the heating or cooling medium enters and leaves the coil.

In water coils, the supply inlet is the pipe stub located on the side where the air leaves the coil. The outlet is the stub on the entering air side of the coil. Such an arrangement is known as counterflow.

In steam coils, the inlet is always the higher stub so that condensate will drain out of the lower stub.

Finned area or face area

The working area of the coil is defined as the width x length of the finned area through which air passes. This finned or face area does not include the casing.

Face velocity

This is the air velocity in fpm across the finned or face area of a coil. Face velocity is determined by dividing the air volume in cfm by the coil face area in square feet.

$$\text{Face Velocity (Fpm)} = \frac{\text{Air Volume (Cfm)}}{\text{Coil Face Area (Sq Ft)}}$$

The first step in selecting an air handler size is to determine the maximum allowable face velocity.

This maximum is determined by the specifier and is based primarily on the following criteria:

1. Avoidance of moisture carryover into the ductwork (applies to cooling coils only).
2. Air pressure drop across the coil.
3. Heat transfer efficiency.

The maximum safe air velocity without moisture carryover into the ductwork depends on the type and spacing of the finned surface, the amount of moisture on the coil, and the geometry between coil and fan inlet or ductwork. Since coil moisture conditions vary, and coil versus duct geometry varies (for example, between draw-thru, blow-thru, vertical, or horizontal units), the specified maximum face velocity should allow for these variations.

Fan horsepower is also affected by face velocity, since the air resistance across the coil varies roughly as the square of the face velocity.

For the above reasons, the maximum specified face velocity is normally a conservative figure (on the low side). Suggested design face velocities are as follows:

COIL TYPE	FACE VELOCITY RANGE
Cooling	400 to 550 fpm
Heating	400 to 800 fpm

In variable air volume (VAV) applications, the system generally operates below peak air volume for extended periods. In such cases, the design face velocity is commonly selected at the higher end of the suggested range.

Tube face

This is the number of tubes in any one coil row.

Below is a diagram of a 4-row coil with a 4-tube face. Note that tubes are staggered in adjacent rows.

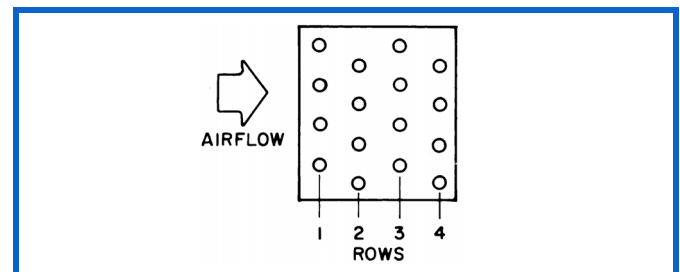

Cooling coils are typically available in 4, 6, 8, and 10-row configurations. Tubes should have an outside diameter (OD) of 1/2 in. to maximize heat transfer at minimum water flows. Coils should be sized for the most efficient use of water. Water temperature differences of 12 to 16°F are typical and represent optimum selection points.

Pass

That part of the circuit that passes through the airstream once.

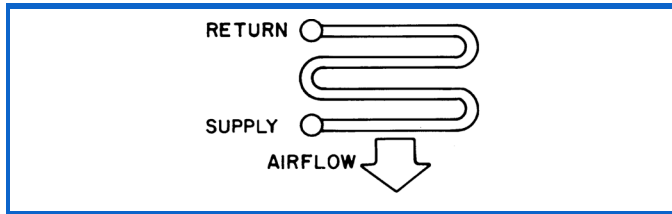

Note that this is a 4-pass circuit.

Direct expansion (DX) coils

Direct expansion coils can have two intertwined refrigerant circuits. In addition, quarter, half, full and double circuiting configurations are offered to allow optimum system performance and oil return at full and part-load operation.

Circuiting selection should result in a circuit loading of 0.8 to 2.0 tons per circuit at design load. Circuit loading must be evaluated at minimum load to ensure that it does not drop below 0.6 tons per circuit. Solenoid valves may be used, if necessary, to shut off the refrigerant supply to individual expansion valves to maintain adequate coil circuit loading.

Compressor minimum unloading and TXV quantity is necessary to determine minimum tonnage per circuit.

Minimum Unloading Equation:

$$\frac{(Tons/Circuit) \times (Minimum\ Unloading) \times (Total\ \# \ of\ TXVs)}{\# \ of\ TXVs\ Active}$$

Example:

Condensing Unit:	38AUZ012
Minimum Unloading:	33%
Coil:	6 row, 11 FPI, Half Circuit
Coil Tons/Circuit:	1.68
Total TXVs:	2

In the first example we will determine the tons/circuit when both TXVs are active and the compressor is unloaded to its minimum of 33%.

$$= \frac{(1.68\ Tons/Circuit) \times (33\% \ Minimum\ Unloading) \times (2\ TXVs)}{2\ TXVs\ Active}$$

$$= \frac{(1.68) \times (.33) \times (2)}{2}$$

=.55 tons/circuit at minimum unloading: UNACCEPTABLE

If we install a liquid line solenoid valve before one of the TXVs and close it so that only one TXV is active when the compressor is unloaded to its minimum of 33%, we see the following:

$$= \frac{(1.68\ Tons/Circuit) \times (33\% \ Minimum\ Unloading) \times (1\ TXV)}{1\ TXV\ Active}$$

$$= \frac{(1.68) \times (.33) \times (2)}{1}$$

= 1.10 tons/circuit at minimum unloading: ACCEPTABLE

Thermostatic expansion valve (TXV) kits are available though **AHUBuilder**® software. If TXVs are purchased from an alternate vendor, be sure to specify a 5% minimum bleed port.

Ethylene glycol

The effects of ethylene glycol usage on coil capacity and pressure drop can be determined from the **AHUBuilder**® program. For a quick estimate of these effects, use the chart below.

The chart is based on 6-row/14-fin coil performance with the only variable being ethylene glycol concentration by weight.

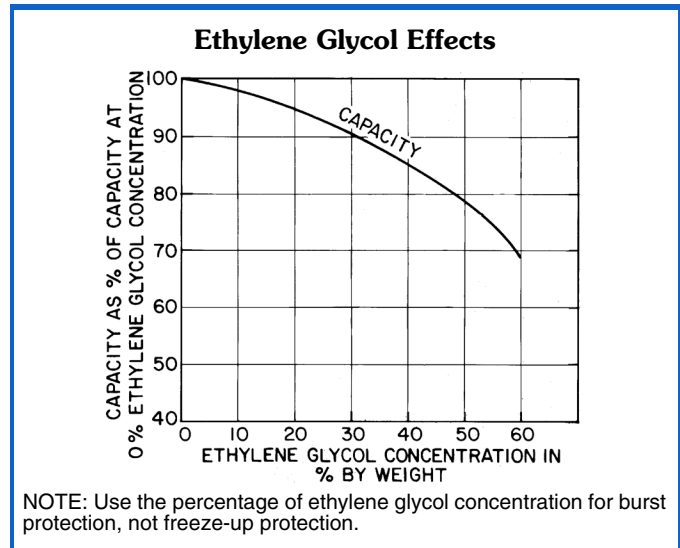

Filters

Air is contaminated in varying degrees by soil, organic matter, spores, bacteria, smoke, dust, and fumes.

Air cleaning and filtration devices are necessary in order to create a cleaner work environment, reduce cleaning costs, and extend the life of machinery or equipment.

Filter ratings (MERV)

Filters are rated according to efficiency and dust-holding capacity.

The most commonly accepted method of testing filter efficiency is per ASHRAE (American Society of Heating, Refrigerating and Air-Conditioning Engineers) Standard 52. An explanation of filter ratings can be found in Chapter 24 of the ASHRAE HVAC Systems and Equipment Handbook. ASHRAE standard 52.2 defines the minimum efficiency reporting value (MERV).

Filter dust-holding capacity is directly related to filter life. The filter is replaced when the amount of dirt and dust it contains builds up air resistance to an unacceptable level. Air resistance build-up is measured by a filter air-resistance gauge.

Size selection

This catalog has been designed to provide a quick and accurate means of selecting and specifying a central station air-handling unit. Start with the information you have: required airflow and preferred coil face velocity to select a nominal unit size. Contact your Carrier sales representative for the **AHUBuilder**® program. Next, refer to the component descriptions. NOTE: Carrier's **AHUBuilder** program provides exact coil and performance data rated in accordance with AHRI Standard 410 for all coils. Chilled water, hot water, and steam coil performance data is certified in accordance with AHRI Standard 410. Carrier's **AHUBuilder** program provides exact fan performance data rated and certified in accordance with AHRI Standard 430. In addition to standard outputs, the program provides coil moisture carryover information. When information from the computer selection programs is not available, use the following general guidelines for velocity limits to avoid moisture carryover.

COIL MOISTURE BLOWOFF LIMITS (FPM)			
FINS PER INCH	ALUMINUM	COPPER	E-COAT
8	550	500	475
11	550	425	400
14	550	375	350

NOTES:

1. See **AHUBuilder** program for specific limitations.
2. Data shown is for general use at 80°F dry bulb (db)/67°F wet bulb (wb) entering air, 55 db/55 wb (°F) leaving air conditions.
3. Units apply to clean, properly maintained coils.

Cost-efficient, computerized selection

The Products and Systems Electronic Catalog is a series of computer programs designed to run on an IBM-compatible personal computer to select products and systems offered by Carrier.

General features:

- Provides “true” selection for all air-handling units coils and fans. Required capacity and/or entering and leaving conditions may be specified with the program determining performance ratings for all applicable coil configurations. User-specified performance rating for a particular configuration or specified performance criteria
- Projection of unit size vs airflow without water carryover problems
- Minimized specifying input criteria — fixed or rarely changing parameters user specified as defaults and separated from main input screen
- Displayed output mode of coil performance ratings allow side-by-side comparison of user-defined performance ratings values (4 calculated values for each coil), or complete performance ratings of all coils in a spreadsheet format
- Detailed summary reports including cooling, heating, fan, acoustic, and physical performance data can be generated in different formats. Fully featured on-line help system contained within the program
- Uses AHRI approved method, reduces engineering expense

Special features

Allows user to continually monitor and modify input/output. Provides processing for special application:

- Ethylene or propylene glycols
- Altitude

Selection procedure (cont)



Electric heat selection procedure

I Determine electric heat requirements based on size of selected unit.

Given:

Air Quantity 3,000 cfm
 Entering-Air Temperature 54 F
 Leaving-Air Temperature 77 F
 Maximum Air Velocity 650 fpm
 Electric Service 208-v and 460-v, 3-ph, 60-Hz
 Unit Type Horizontal Draw-Thru

II Determine heating load.

$$\begin{aligned} \text{Heating Load} &= 1.1 \times \text{Cfm} \times \text{Air Temp Rise} \\ &= 1.1 \times 3,000 \times 23 \\ &= 75,900 \text{ Btuh (75.9 MBtuh)} \end{aligned}$$

III Verify unit size.

Size of the electric heating coil face area is usually predetermined by the selection of the air-handling unit and the cooling coil. However, the heater size must be checked to assure that the minimum face velocity is provided for the heater.

$$\begin{aligned} \text{Minimum Face Area} &= \frac{3,000}{650 \text{ Fpm}} \\ &= 4.6 \text{ sq ft} \end{aligned}$$

$$\begin{aligned} \text{Actual Face Velocity} &= \frac{3,000}{4.9 \text{ sq ft}} \quad (\text{Actual Coil Face Area}) \\ &= 615 \text{ Fpm} \end{aligned}$$

IV Determine kilowatt equivalent of heating load.

$$\begin{aligned} \text{kW Heating Load} &= \frac{75.9 \text{ MBtuh}}{3.413 \text{ MBtuh/kW}} \\ &= \frac{75.9}{3.413} \\ &= 22.2 \text{ kW} \end{aligned}$$

V Determine unit electric heater size.

Select the heater which has a kW rating closest to but greater than the required kW and is available at the required voltage. Electric heaters are available in one-kW increments. The Electric Heater Data on pages 54-74 shows incremental sizes only.

VI Determine capacity of electric heater.

$$\begin{aligned} \text{Capacity} &= 23 \text{ kW} \times 3.413 \\ &= 78.5 \text{ MBtuh} \end{aligned}$$

VII Calculate air temperature rise.

$$\begin{aligned} \text{Air Temp Rise} &= \frac{78,500 \text{ Btuh}}{1.1 \times 3,000 \text{ Cfm}} \\ &= 23.8^\circ\text{F} \end{aligned}$$

VIII Calculate the actual leaving-air temperature.

$$\begin{aligned} \text{Leaving Air Temp} &= \text{Ent Air Temp} + \text{Air Temp Rise} \\ &= 54 + 23.8 \\ &= 77.8^\circ\text{F} \end{aligned}$$

IX Determine air friction loss of electric heating coil.

Enter Component Pressure Drop table, page 53, and find (by interpolation) air friction loss of electric heater at 615 fpm to be 0.02 in. wg.

X Voltage variations.

Variations from the rated voltage of the electric heating coils can significantly affect the coil's rated output. The effects of voltage variation can be determined by the following formula.

$$\text{kW}_a = \text{kW}_r \times \left(\frac{V_a}{V_r} \right)^2$$

kW_a = Actual kW Output From Coil
 kW_r = Rated kW Output From Coil
 V_a = Actual Voltage at Coil
 V_r = Rated Voltage at Coil

Air handler selection guide

1. Unit size = Coil face area (ft²) = design cfm/max face velocity
 Example: 12,000 cfm/500 fpm = 24 → Size 25
2. Consider your system and choose the appropriate component sections.
3. Determine overall unit dimensions and weight. The height and width for any given unit size is the same for all component sections.
4. Finalize your selections using Carrier's latest version of the **AHUBuilder**® program. The **AHUBuilder** program is a comprehensive selection tool designed to help our customers quickly and efficiently make the proper air handler choice.

Size 03W (1500 cfm)

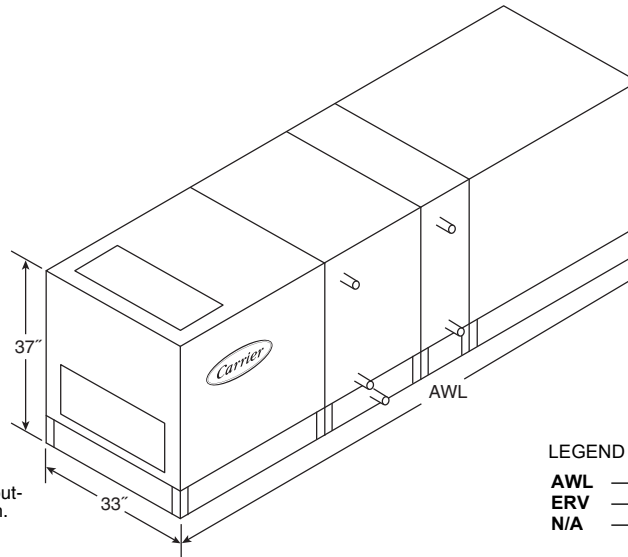

NOTES:

- Dimensions are shown for indoor units. For outdoor units add 4 in. to height and 3 in. to width.
- Height dimensions include 6-in. base rail.

LEGEND

- AWL** — Airway Length
- ERV** — Energy Recovery Ventilator
- N/A** — Not Applicable

AIR DISTRIBUTION COMPONENTS		AWL (in.)	Weight (lb)	DAMPER QTY		
	Mixing Box	18	142	1		
	Side Inlet Mixing Box	21	158	1		
	Filter Mixing Box (2-in. or 4-in. Flat Filter)	25	222	1		
	Filter Mixing Box (6-in. Flat Filter)	27	231	1		
	Filter Mixing Box (Angle Filter)	36	274	1		
	Filter Mixing Box (Angle Filter) with Smoke Damper	42	323	1		
	Filter Mixing Box (Bag Cartridge Filter)	38	284	1		
	Air Mixer	18	167	N/A		
	Exhaust Box	18	159	1		
	Side Outlet Exhaust Box	21	171	1		
	Internal Face and Bypass Damper	18	137	1		
	External Face and Bypass Damper Section	18	219	1		
FILTRATION COMPONENTS		AWL (in.)	Weight (lb)	FILTER QTY	FILTER SIZE (in.)	FILTER AREA (ft ²)
	2-in. or 4-in. Flat Filter	12	189	1	25 x 20	3.5
	2-in. Pre-Filter with 4-in. Flat Filter	14	195	1	25 x 20	3.5
	2-in. or 4-in. Angle Filter	24	224	2	16 x 25	5.6
	Short Bag/Side Loading Cartridge Filter	24	228	1	24 x 24	4.0
	Long Bag/Side Loading Cartridge Filter	42	282	1	24 x 24	4.0
	Bag/Front Loading Cartridge Filter	48	301	1	24 x 24	4.0
	Blow-thru Front Loading HEPA Filter	48	301	1	24 x 24	4.0
HEAT TRANSFER SECTIONS		MIN AWL (in.)	MIN Weight (lb)	MAX AWL (in.)	MAX Weight (lb)	
	Coil and Variable Length Plenum (with Drain Pan)	24	155	61	275	
	Coil and Variable Length Plenum (without Drain Pan)	12	119	60	264	
	Dual Coil and Variable Length Plenum (with Drain Pan)	30	155	61	275	
	Vertical Coil	42	216	N/A	N/A	
	Internal Face and Bypass Cooling Coil	24	155	N/A	N/A	
	Internal Face and Bypass Heating Coil	12	119	24	155	
	Electric Heat with Control Box (Low Amp [min]/High Amp [max])	24	196	36	232	
AIR MOVEMENT SECTIONS*		MIN AWL (in.)†	MIN Weight (lb)†	MAX AWL (in.)**	MAX Weight (lb)**	
	Airfoil Fan	39	559	39	588	
	Downblast Airfoil Fan	39	559	39	588	
	Forward Curved Fan	24	512	24	557	
	Belt-Drive Plenum Fan	48	602	48	632	
	Direct Drive Plenum Fan	34	302	39	372	
	Vertical Forward Curve Fan	42	587	42	632	
	Vertical Airfoil Fan	42	581	42	611	
	Horizontal Direct Drive Plenum Fan with EC Motor	Variable depending upon fan size, quantity, and options. See AHUBuilder.				
	Vertical Direct Drive Plenum Fan with EC Motor	Variable depending upon fan size, quantity, and options. See AHUBuilder.				
MISCELLANEOUS SECTIONS		MIN AWL (in.)	MIN Weight (lb)	MAX AWL (in.)	MAX Weight (lb)	
	ERV Section	103	1676	N/A	N/A	
	Humidifier	24	254	48	326	
	Access and Plenum	12	121	48	230	
	Turning Plenum	24	169	N/A	N/A	
	Sound Attenuator	36	264	60	382	

* Refer to **AHUBuilder**® program for application specific weight and AWL.

† Minimum is based on smallest motor and smallest fan wheel combination.

** Maximum is based on largest motor and largest fan wheel combination.

Size 06W (3000 cfm)

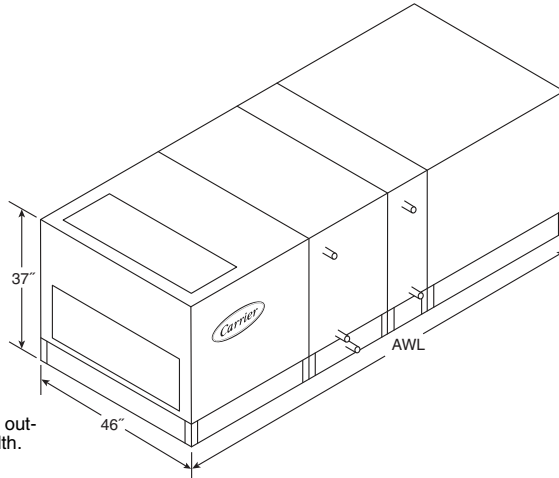

LEGEND

- AWL** — Airway Length
- ERV** — Energy Recovery Ventilator
- N/A** — Not Applicable

NOTES:

1. Dimensions are shown for indoor units. For outdoor units add 4 in. to height and 3 in. to width.
2. Height dimensions include 6-in. base rail.

AIR DISTRIBUTION COMPONENTS		AWL (in.)	Weight (lb)	DAMPER QTY		
Mixing Box		21	169	1		
Side Inlet Mixing Box		27	198	1		
Filter Mixing Box (2-in. or 4-in. Flat Filter)		28	279	1		
Filter Mixing Box (6-in Flat Filter)		30	290	1		
Filter Mixing Box (Angle Filter)		36	323	1		
Filter Mixing Box (Angle Filter) with Smoke Damper		42	388	1		
Filter Mixing Box (Bag Cartridge Filter)		41	351	1		
Air Mixer		18	198	N/A		
Exhaust Box		21	192	1		
Side Outlet Exhaust Box		27	214	1		
Internal Face and Bypass Damper		18	156	1		
External Face and Bypass Damper Section		21	291	1		
Multizone Damper (Front Discharge) (Two Deck)		5	90	N/A		
Multizone Damper (Top Discharge) (Two Deck)		5 (height)	90	N/A		
FILTRATION COMPONENTS		AWL (in.)	Weight (lb)	FILTER QTY	FILTER SIZE (in.)	FILTER AREA (ft ²)
2-in. or 4-in. Flat Filter		12	227	2	25 x 20	6.9
2-in. Pre-Filter with 4-in. Flat Filter		14	234	2	25 x 20	6.9
2-in. or 4-in. Angle Filter		24	269	4	16 x 20	8.9
Short Bag/Side Loading Cartridge Filter		24	273	1 / 1	24 x 24 / 24 x 12	6.0
Long Bag/Side Loading Cartridge Filter		42	336	1 / 1	24 x 24 / 24 x 12	6.0
Bag/Front Loading Cartridge Filter		48	357	1 / 1	24 x 24 / 24 x 12	6.0
Blow-thru Front Loading HEPA Filter		48	357	1 / 1	24 x 24 / 24 x 12	6.0
HEAT TRANSFER SECTIONS		MIN AWL (in.)	MIN Weight (lb)	MAX AWL (in.)	MAX Weight (lb)	Zones
Coil and Variable Length Plenum (with Drain Pan)		24	177	61	318	
Coil and Variable Length Plenum (without Drain Pan)		12	135	60	303	
Dual Coil and Variable Length Plenum (with Drain Pan)		30	177	61	318	
Vertical Coil		42	245	N/A	N/A	
Multizone Front Discharge		49	629	N/A	N/A	6 zones
Multizone Top Discharge		49	599	N/A	N/A	6 zones
Internal Face and Bypass Cooling Coil		24	177	N/A	N/A	
Internal Face and Bypass Heating Coil		12	135	24	177	
Integral Face and Bypass Heating Coil		48	265	N/A	N/A	
Electric Heat with Control Box (Low Amp [min]/High Amp [max])		30	264	36	285	
Gas Heat (Low BTU [min]/High BTU [max])		61	498	97	871	
AIR MOVEMENT SECTIONS*		MIN AWL (in.)†	MIN Weight (lb)†	MAX AWL (in.)**	MAX Weight (lb)**	
Airfoil Fan		39	674	40	700	
Downblast Airfoil Fan		39	670	40	700	
Forward Curved Fan		30	654	30	667	
Belt-Drive Plenum Fan		54	763	54	820	
Direct Drive Plenum Fan		36	405	43	520	
Vertical Forward Curve Fan		42	696	42	734	
Vertical Airfoil Fan		42	696	42	727	
Horizontal Direct Drive Plenum Fan with EC Motor						Variable depending upon fan size, quantity, and options. See AHUBuilder.
Vertical Direct Drive Plenum Fan with EC Motor						Variable depending upon fan size, quantity, and options. See AHUBuilder.
MISCELLANEOUS SECTIONS		MIN AWL (in.)	MIN Weight (lb)	MAX AWL (in.)	MAX Weight (lb)	
ERV Section		103	1987	103	2086	
Humidifier		24	295	48	379	
Access and Plenum		12	139	48	264	
Turning Plenum		24	195	N/A	N/A	
Sound Attenuator		36	327	60	477	

* Refer to **AHUBuilder**® program for application specific weight and AWL.

† Minimum is based on smallest motor and smallest fan wheel combination.

** Maximum is based on largest motor and largest fan wheel combination.

Size 07T (3500 cfm)

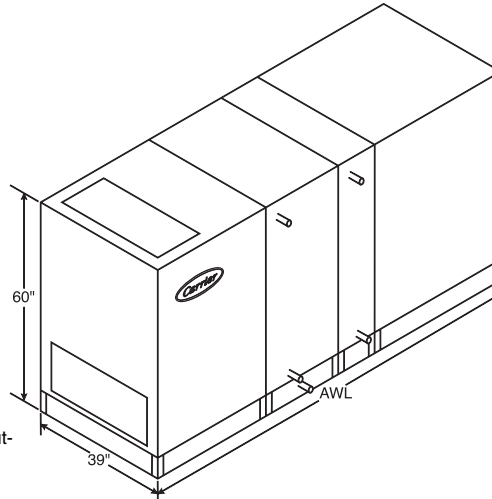

NOTES:

1. Dimensions are shown for indoor units. For outdoor units add 4 in. to height and 3 in. to width.
2. Height dimensions include 6-in. base rail.

LEGEND

- AWL** — Airway Length
- ERV** — Energy Recovery Ventilator
- N/A** — Not Applicable

AIR DISTRIBUTION COMPONENTS		AWL (in.)	Weight (lb)	DAMPER QUANTITY		
	Mixing Box	27	192	1		
	Side Inlet Mixing Box	21	262	2		
	Filter Mixing Box (2-in. or 4-in. Flat Filter)	34	306	1		
	Filter Mixing Box (6-in. Flat Filter)	36	323	1		
	Filter Mixing Box (Angle Filter)	37	331	1		
	Filter Mixing Box (Angle Filter) with Smoke Damper	50	477	1		
	Filter Mixing Box (Bag Cartridge Filter)	47	417	1		
	Air Mixer	18	241	N/A		
	Exhaust Box	27	216	1		
	Combination Exhaust Mixing Box	21	212	2		
	Side Outlet Exhaust Box	21	276	2		
	Internal Face and Bypass Damper	18	191	1		
	External Face and Bypass Damper Section				Future offering	
	Multizone Damper (Front Discharge) (Two Deck)				Future offering	
	Multizone Damper (Top Discharge) (Two Deck)				Future offering	
FILTRATION COMPONENTS		AWL (in.)	Weight (lb)	FILTER QUANTITY	FILTER SIZE (in.)	FILTER AREA (ft ²)
	2-in. or 4-in. Flat Filter	12	273	4	20 x 16	8.9
	2-in. Pre-Filter with 4-in. Flat Filter	14	282	4	20 x 16	8.9
	2-in. or 4-in. Angle Filter	27	322	4	25 x 16	11.1
	Short Bag/Side Loading Cartridge Filter	24	329	2	24 x 24	8.0
	Long Bag/Side Loading Cartridge Filter	42	408	2	24 x 24	8.0
	Bag/Front Loading Cartridge Filter	48	435	2	24 x 24	8.0
	Blow-thru Front Loading HEPA Filter	48	435	2	24 x 24	8.0
HEAT TRANSFER SECTIONS		MIN AWL (in.)	MIN Weight (lb)	MAX AWL (in.)	MAX Weight (lb)	
	Coil and Variable Length Plenum (with Drain Pan)	24	217	61	398	
	Coil and Variable Length Plenum (without Drain Pan)	12	165	60	382	
	Dual Coil and Variable Length Plenum (with Drain Pan)	30	217	61	398	
	Vertical Coil					Future offering
	Multizone Front Discharge					Future offering
	Multizone Top Discharge					Future offering
	Internal Face and Bypass Cooling Coil	24	217	N/A	N/A	
	Internal Face and Bypass Heating Coil	12	165	24	217	
	Integral Face and Bypass Heating Coil	48	317	N/A	N/A	
	Electric Heat with Control Box (Low Amp [min]/High Amp [max])	30	319	42	353	
	Gas Heat (Low BTU) [min]/High Amp [max]					Future offering
AIR MOVEMENT SECTIONS*		MIN AWL (in.)†	MIN Weight (lb)†	MAX AWL (in.)**	MAX Weight (lb)**	
	Airfoil Fan	48	806	57	858	
	Downblast Airfoil Fan	48	804	57	892	
	Forward Curved Fan	40	765	49	803	
	Belt-Drive Plenum Fan					Future offering
	Direct Drive Plenum Fan	35	434	44	706	
	Fan Array					Future offering
	Vertical Forward Curve Fan					Future offering
	Vertical Airfoil Fan					Future offering
	Horizontal Direct Drive Plenum Fan with EC Motor					Variable depending upon fan size, quantity, and options. See AHUBuilder.
MISCELLANEOUS SECTIONS		MIN AWL (in.)	MIN Weight (lb)	MAX AWL (in.)	MAX Weight (lb)	
	ERV Section					Future offering
	Humidifier	24	317	48	411	
	Access and Plenum	12	171	48	317	
	Turning Plenum					Future offering
	Sound Attenuator	36	433	60	644	

* Refer to AHUBuilder® program for application specific weight and AWL.

† Minimum is based on smallest motor and smallest fan wheel combination.

** Maximum is based on largest motor and largest fan wheel combination.

Dimensions (cont)



Size 08W (4000 cfm)

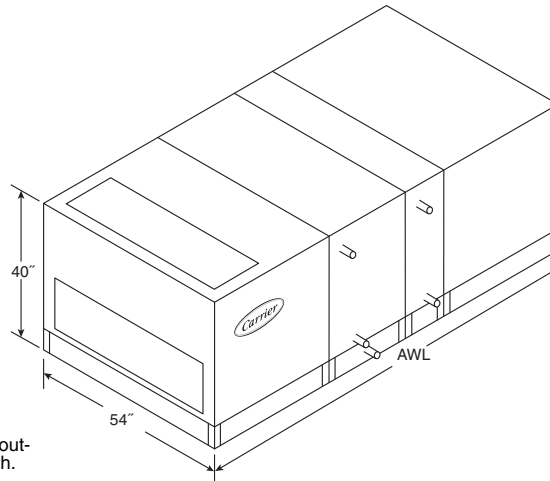

NOTES:

1. Dimensions are shown for indoor units. For outdoor units add 4 in. to height and 3 in. to width.
2. Height dimensions include 6-in. base rail.

LEGEND

- AWL** — Airway Length
- ERV** — Energy Recovery Ventilator
- N/A** — Not Applicable

AIR DISTRIBUTION COMPONENTS		AWL (in.)	Weight (lb)	DAMPER QUANTITY		
Mixing Box		21	188	1		
Side Inlet Mixing Box		27	223	1		
Filter Mixing Box (2-in. or 4-in. Flat Filter)		28	317	1		
Filter Mixing Box (6-in. Flat Filter)		30	329	1		
Filter Mixing Box (Angle Flat Filter)		36	365	1		
Filter Mixing Box (Angle Filter) with Smoke Damper		42	440	1		
Filter Mixing Box (Bag Cartridge Flat Filter)		41	396	1		
Air Mixer		18	224	N/A		
Exhaust Box		21	213	1		
Side Outlet Exhaust Box		27	238	1		
Combination Exhaust Mixing Box		27	207	1		
Internal Face and Bypass Damper		18	172	1		
External Face and Bypass Damper Section		21	336	1		
Multizone Damper (Front Discharge) (Two Deck)		5	105	N/A		
Multizone Damper (Top Discharge) (Two Deck)		5 (height)	104	N/A		
FILTRATION COMPONENTS		AWL (in.)	Weight (lb)	FILTER QUANTITY	FILTER SIZE (in.)	FILTER AREA (ft²)
2-in. or 4-in. Flat Filter		12	255	3	25 x 16	8.3
2-in. Pre-Filter with 4-in. Flat Filter		14	263	3	25 x 16	8.3
2-in. or 4-in. Angle Filter		24	302	4	16 x 25	11.1
Short Bag/Side Loading Cartridge Filter		24	306	2	24 x 24	8.0
Long Bag/Side Loading Cartridge Filter		42	377	2	24 x 24	8.0
Bag/Front Loading Cartridge Filter		48	400	2	24 x 24	8.0
Blow-thru Front Loading HEPA Filter		48	400	2	24 x 24	8.0
HEAT TRANSFER SECTIONS		MIN AWL (in.)	MIN Weight (lb)	MAX AWL (in.)	MAX Weight (lb)	Zones
Coil and Variable Length Plenum (with Drain Pan)		24	195	61	353	
Coil and Variable Length Plenum (without Drain Pan)		12	148	60	336	
Dual Coil and Variable Length Plenum (with Drain Pan)		30	195	61	353	
Vertical Coil		36	253	N/A	N/A	
Multizone Front Discharge		49	694	N/A	N/A	7 zones
Multizone Top Discharge		49	658	N/A	N/A	7 zones
Internal Face and Bypass Cooling Coil		24	195	N/A	N/A	
Internal Face and Bypass Heating Coil		12	148	24	195	
Integral Face and Bypass Heating Coil		48	293	N/A	N/A	
Electric Heat with Control Box (Low Amp [min]/High Amp [max])		30	301	42	348	
Gas Heat (Low BTU [min]/High BTU [max])		85	800	121	1216	
AIR MOVEMENT SECTIONS*		MIN AWL (in.)†	MIN Weight (lb)†	MAX AWL (in.)**	MAX Weight (lb)**	
Airfoil Fan		40	772	40	795	
Downblast Airfoil Fan		40	761	40	823	
Forward Curved Fan		36	799	36	755	
Belt-Drive Plenum Fan		54	844	42	859	
Direct Drive Plenum Fan		38	462	46	706	
Fan Array		37	514	39	700	
Vertical Forward Curve Fan		36	784	36	784	
Vertical Airfoil Fan		36	771	36	829	
Horizontal Direct Drive Plenum Fan with EC Motor		Variable depending upon fan size, quantity, and options. See AHUBuilder.				
Vertical Direct Drive Plenum Fan with EC Motor		Variable depending upon fan size, quantity, and options. See AHUBuilder.				
MISCELLANEOUS SECTIONS		MIN AWL (in.)	MIN Weight (lb)	MAX AWL (in.)	MAX Weight (lb)	
ERV Section		109	2328	109	2463	
Humidifier		24	325	48	419	
Access and Plenum		12	152	48	293	
Turning Plenum		24	218	N/A	N/A	
Sound Attenuator		36	372	60	521	

* Refer to AHUBuilder® program for application specific weight and AWL.

† Minimum is based on smallest motor and smallest fan wheel combination.

** Maximum is based on largest motor and largest fan wheel combination.

Dimensions (cont)



Size 09T (4500 cfm)

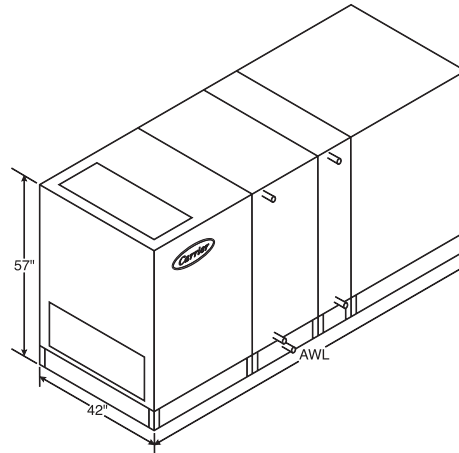

NOTES:

1. Dimensions are shown for indoor units. For outdoor units add 4 in. to height and 3 in. to width.
2. Height dimensions include 6-in. base rail.

LEGEND

- AWL** — Airway Length
ERV — Energy Recovery Ventilator
N/A — Not Applicable

AIR DISTRIBUTION COMPONENTS	AWL (in.)	Weight (lb)	DAMPER QUANTITY		
Mixing Box	27	210	1		
Side Inlet Mixing Box	27	285	2		
Filter Mixing Box (2-in. or 4-in. Flat Filter)	34	349	1		
Filter Mixing Box (6-in. Flat Filter)	36	363	1		
Filter Mixing Box (Angle Filter)	37	369	1		
Filter Mixing Box (Angle Filter) with Smoke Damper	50	497	1		
Filter Mixing Box (Bag Cartridge Filter)	47	438	1		
Air Mixer	18	268	N/A		
Exhaust Box	27	236	1		
Combination Exhaust Mixing Box	27	231	2		
Side Outlet Exhaust Box	27	300	2		
Internal Face and Bypass Damper	18	198	1		
External Face and Bypass Damper Section				Future offering	
Multizone Damper (Front Discharge) (Two Deck)				Future offering	
Multizone Damper (Top Discharge) (Two Deck)				Future offering	

FILTRATION COMPONENTS	AWL (in.)	Weight (lb)	FILTER QUANTITY	FILTER SIZE (in.)	FILTER AREA (ft ²)
2-in. or 4-in. Flat Filter	12	293	4	20 x 16	8.9
2-in. Pre-Filter with 4-in. Flat Filter	14	302	4	20 x 16	8.9
2-in. or 4-in. Angle Filter	27	345	4	25 x 16	11.1
Short Bag/Side Loading Cartridge Filter	24	352	1 1/2	24 x 24 / 12 x 24	8.0
Long Bag/Side Loading Cartridge Filter	42	434	1 1/2	24 x 24 / 12 x 24	8.0
Bag/Front Loading Cartridge Filter	48	461	1 1/2	24 x 24 / 12 x 24	8.0
Blow-thru Front Loading HEPA Filter	48	462	1 1/2	24 x 24 / 12 x 24	8.0

HEAT TRANSFER SECTIONS	MIN AWL (in.)	MIN Weight (lb)	MAX AWL (in.)	MAX Weight (lb)
Coil and Variable Length Plenum (with Drain Pan)	24	225	61	415
Coil and Variable Length Plenum (without Drain Pan)	12	171	60	397
Dual Coil and Variable Length Plenum (with Drain Pan)	30	225	61	415
Vertical Coil				
Multizone Front Discharge				Future offering
Multizone Top Discharge				Future offering
Internal Face and Bypass Cooling Coil	24	225	N/A	N/A
Internal Face and Bypass Heating Coil	12	171	24	225
Integral Face and Bypass Heating Coil	48	331	N/A	N/A
Electric Heat with Control Box (Low Amp [min]/High Amp) [max]	30	344	42	377
Gas Heat (Low BTU) [min]/(High BTU) [max]				Future offering

AIR MOVEMENT SECTIONS*	MIN AWL (in.)†	MIN Weight (lb)†	MAX AWL (in.)**	MAX Weight (lb)**
Airfoil Fan	48	843	57	937
Downblast Airfoil Fan	48	861	57	972
Forward Curved Fan	40	824	49	883
Belt-Drive Plenum Fan				Future offering
Direct Drive Plenum Fan	38	509	47	787
Fan Array				Future offering
Vertical Forward Curve Fan				Future offering
Vertical Airfoil Fan				Future offering
Horizontal Direct Drive Plenum Fan with EC Motor				Variable depending upon fan size, quantity, and options. See AHUBuilder.

MISCELLANEOUS SECTIONS	MIN AWL (in.)	MIN Weight (lb)	MAX AWL (in.)	MAX Weight (lb)
ERV Section				Future offering
Humidifier	24	341	48	441
Access and Plenum	12	178	48	331
Turning Plenum				Future offering
Sound Attenuator	36	379	60	570

* Refer to AHUBuilder® program for application specific weight and AWL.
† Minimum is based on smallest motor and smallest fan wheel combination.
** Maximum is based on largest motor and largest fan wheel combination.

Size 10W (5000 cfm)

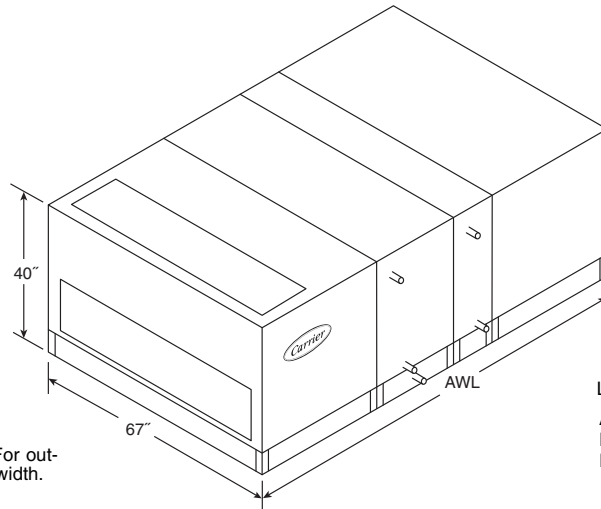

NOTES:

1. Dimensions are shown for indoor units. For outdoor units add 4 in. to height and 3 in. to width.
2. Height dimensions include 6-in. base rail.

LEGEND

- AWL** — Airway Length
- ERV** — Energy Recovery Ventilator
- N/A** — Not Applicable

AIR DISTRIBUTION COMPONENTS	AWL (in.)	Weight (lb)	DAMPER QUANTITY		
Mixing Box	21	210	1		
Side Inlet Mixing Box	33	277	1		
Filter Mixing Box (2-in. or 4-in. Flat Filter)	28	356	1		
Filter Mixing Box (6-in. Flat Filter)	30	370	1		
Filter Mixing Box (Angle Filter)	36	410	1		
Filter Mixing Box (Angle Filter) with Smoke Damper	42	496	1		
Filter Mixing Box (Bag Cartridge Filter)	41	445	1		
Air Mixer	24	281	N/A		
Exhaust Box	21	236	1		
Side Outlet Exhaust Box	33	291	1		
Combination Exhaust Mixing Box	33	231	1		
Internal Face and Bypass Damper	18	191	1		
External Face and Bypass Damper Section	21	384	1		
Multizone Damper (Front Discharge) (Two Deck)	5	118	N/A		
Multizone Damper (Top Discharge) (Two Deck)	5 (height)	118	N/A		
FILTRATION COMPONENTS	AWL (in.)	Weight (lb)	FILTER QUANTITY	FILTER SIZE (in.)	FILTER AREA (ft ²)
2-in. or 4-in. Flat Filter	12	286	3	25 x 20	10.4
2-in. Pre-Filter with 4-in. Flat Filter	14	295	3	25 x 20	10.4
2-in. or 4-in. Angle Filter	24	339	6	16 x 20	13.3
Short Bag/Side Loading Cartridge Filter	24	343	1 / 1	24 x 24 / 24 x 12	10.0
Long Bag/Side Loading Cartridge Filter	42	422	1 / 1	24 x 24 / 24 x 12	10.0
Bag/Front Loading Cartridge Filter	48	449	2 / 1	24 x 24 / 24 x 12	10.0
Blow-thru Front Loading HEPA Filter	48	449	2 / 1	24 x 24 / 24 x 12	10.0
HEAT TRANSFER SECTIONS	MIN AWL (in.)	MIN Weight (lb)	MAX AWL (in.)	MAX Weight (lb)	Zones
Coil and Variable Length Plenum (with Drain Pan)	24	217	61	403	
Coil and Variable Length Plenum (without Drain Pan)	12	165	60	390	
Dual Coil and Variable Length Plenum (with Drain Pan)	30	217	61	403	
Vertical Coil	36	281	N/A	N/A	
Multizone Front Discharge	49	901	N/A	N/A	10 zones
Multizone Top Discharge	49	853	N/A	N/A	10 zones
Internal Face and Bypass Cooling Coil	24	217	N/A	N/A	
Internal Face and Bypass Heating Coil	12	165	24	217	
Integral Face and Bypass Heating Coil	48	327	N/A	N/A	
Electric Heat with Control Box (Low Amp [min]/High Amp [max])	30	344	42	397	
Gas Heat (Low BTU [min]/High BTU [max])	85	903	121	1359	
AIR MOVEMENT SECTIONS*	MIN AWL (in.)†	MIN Weight (lb)†	MAX AWL (in.)**	MAX Weight (lb)**	
Airfoil Fan	40	849	34	887	
Downblast Airfoil Fan	40	849	34	887	
Forward Curved Fan	36	874	36	830	
Belt-Drive Plenum Fan	42	899	42	1072	
Direct Drive Plenum Fan	42	555	48	785	
Fan Array	37	578	41	785	
Vertical Forward Curve Fan	36	867	36	912	
Vertical Airfoil Fan	36	848	36	932	
Horizontal Direct Drive Plenum Fan with EC Motor	Variable depending upon fan size, quantity, and options. See AHUBuilder.				
Vertical Direct Drive Plenum Fan with EC Motor	Variable depending upon fan size, quantity, and options. See AHUBuilder.				
MISCELLANEOUS SECTIONS	MIN AWL (in.)	MIN Weight (lb)	MAX AWL (in.)	MAX Weight (lb)	
ERV Section	109	2563	128	2891	
Humidifier	24	360	48	465	
Access and Plenum	12	169	48	327	
Turning Plenum	24	244	N/A	N/A	
Sound Attenuator	36	434	60	658	

* Refer to **AHUBuilder**® program for application specific weight and AWL.
 † Minimum is based on smallest motor and smallest fan wheel combination.

** Maximum is based on largest motor and largest fan wheel combination.

Dimensions (cont)



Size 11T (5500 cfm)

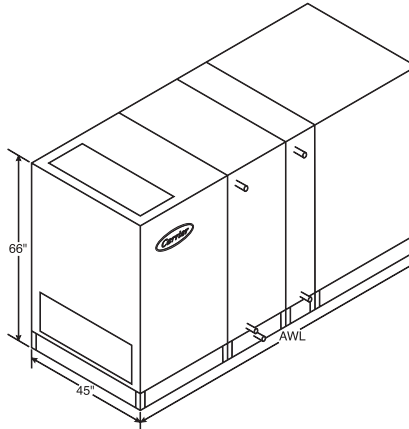

NOTES:

1. Dimensions are shown for indoor units. For outdoor units add 4 in. to height and 3 in. to width.
2. Height dimensions include 6-in. base rail.

LEGEND

- AWL** — Airway Length
- ERV** — Energy Recovery Ventilator
- N/A** — Not Applicable

AIR DISTRIBUTION COMPONENTS	AWL (in.)	Weight (lb)	DAMPER QUANTITY
Mixing Box	33	237	1
Side Inlet Mixing Box	27	320	2
Filter Mixing Box (2-in. or 4-in. Flat Filter)	40	420	1
Filter Mixing Box (6-in. Flat Filter)	42	435	1
Filter Mixing Box (Angle Filter)	41	427	1
Filter Mixing Box (Angle Filter) with Smoke Damper	52	563	1
Filter Mixing Box (Bag Cartridge Filter)	53	515	1
Air Mixer	24	309	N/A
Exhaust Box	33	267	1
Combination Exhaust Mixing Box	27	261	2
Side Outlet Exhaust Box	27	334	2
Internal Face and Bypass Damper	18	210	1
External Face and Bypass Damper Section			<i>Future offering</i>
Multizone Damper (Front Discharge) (Two Deck)			<i>Future offering</i>
Multizone Damper (Top Discharge) (Two Deck)			<i>Future offering</i>

FILTRATION COMPONENTS	AWL (in.)	Weight (lb)	FILTER QUANTITY	FILTER SIZE (in.)	FILTER AREA (ft²)
2-in. or 4-in. Flat Filter	12	324	4	25 x 20	11.1
2-in. Pre-Filter with 4-in. Flat Filter	14	333	4	25 x 20	11.1
2-in. or 4-in. Angle Filter	23	379	8	16 x 20	17.8
Short Bag/Side Loading Cartridge Filter	24	386	2 / 2	24 x 24 / 12 x 24	12.0
Long Bag/Side Loading Cartridge Filter	42	472	2 / 2	24 x 24 / 12 x 24	12.0
Bag/Front Loading Cartridge Filter	48	501	2 / 2	24 x 24 / 12 x 24	12.0
Blow-thru Front Loading HEPA Filter	48	501	2 / 2	24 x 24 / 12 x 24	12.0

HEAT TRANSFER SECTIONS	MIN AWL (in.)	MIN Weight (lb)	MAX AWL (in.)	MAX Weight (lb)
Coil and Variable Length Plenum (with Drain Pan)	24	234	61	431
Coil and Variable Length Plenum (without Drain Pan)	12	178	60	412
Dual Coil and Variable Length Plenum (with Drain Pan)	30	234	61	431
Vertical Coil				<i>Future offering</i>
Multizone Front Discharge				<i>Future offering</i>
Multizone Top Discharge				<i>Future offering</i>
Internal Face and Bypass Cooling Coil	24	234	N/A	N/A
Internal Face and Bypass Heating Coil	12	178	24	233
Integral Face and Bypass Heating Coil				<i>Future offering</i>
Electric Heat with Control Box (Low Amp [min]/High Amp [max])	30	369	42	401
Gas Heat (Low BTU)[min]/(High BTU)[max]				<i>Future offering</i>

AIR MOVEMENT SECTIONS*	MIN AWL (in.)†	MIN Weight (lb)†	MAX AWL (in.)**	MAX Weight (lb)**
Airfoil Fan	53	993	65	1017
Downblast Airfoil Fan	53	1007	65	1053
Forward Curved Fan	43	919	55	963
Belt-Drive Plenum Fan				<i>Future offering</i>
Direct Drive Plenum Fan	40	583	49	867
Fan Array				<i>Future offering</i>
Vertical Forward Curve Fan				<i>Future offering</i>
Vertical Airfoil Fan				<i>Future offering</i>
Horizontal Direct Drive Plenum Fan with EC Motor				Variable depending upon fan size, quantity, and options. See AHUBuilder.

MISCELLANEOUS SECTIONS	MIN AWL (in.)	MIN Weight (lb)	MAX AWL (in.)	MAX Weight (lb)
ERV Section				<i>Future offering</i>
Humidifier	24	366	48	471
Access and Plenum	12	185	48	344
Turning Plenum				<i>Future offering</i>
Sound Attenuator	36	512	60	802

* Refer to AHUBuilder® program for application specific weight and AWL.

† Minimum is based on smallest motor and smallest fan wheel combination.

** Maximum is based on largest motor and largest fan wheel combination.

Size 12T (6000 cfm)

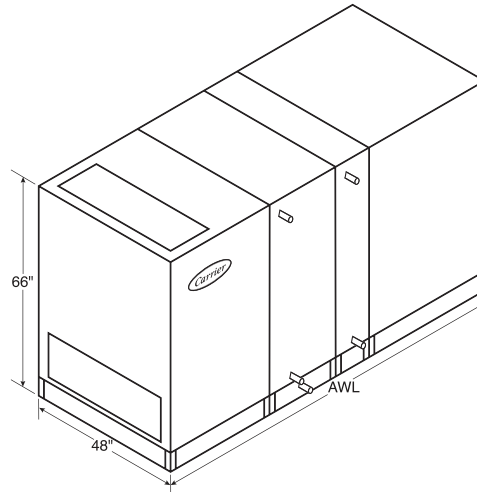

NOTES:

1. Dimensions are shown for indoor units. For outdoor units add 4 in. to height and 3 in. to width.
2. Height dimensions include 6-in. base rail.

LEGEND

- AWL** — Airway Length
- ERV** — Energy Recovery Ventilator
- N/A** — Not Applicable

AIR DISTRIBUTION COMPONENTS	AWL (in.)	Weight (lb)	DAMPER QUANTITY		
Mixing Box	33	237	1		
Side Inlet Mixing Box	27	320	2		
Filter Mixing Box (2-in. or 4-in. Flat Filter)	40	420	1		
Filter Mixing Box (6-in. Flat Filter)	42	435	1		
Filter Mixing Box (Angle Filter)	41	427	1		
Filter Mixing Box (Angle Filter) with Smoke Damper	52	584	1		
Filter Mixing Box (Bag Cartridge Filter)	53	515	1		
Air Mixer	24	309	N/A		
Exhaust Box	33	267	1		
Side Outlet Exhaust Box	27	261	2		
Combination Exhaust Mixing Box	27	334	2		
Internal Face and Bypass Damper	18	210	1		
External Face and Bypass Damper Section				Future offering	
Multizone Damper (Front Discharge) (Two Deck)				Future offering	
Multizone Damper (Top Discharge) (Two Deck)				Future offering	
FILTRATION COMPONENTS	AWL (in.)	Weight (lb)	FILTER QUANTITY	FILTER SIZE (in.)	FILTER AREA (ft ²)
2-in. or 4-in. Flat Filter	12	324	4	25 x 20	13.9
2-in. Pre-Filter with 4-in. Flat Filter	14	333	4	25 x 20	13.9
2-in. or 4-in. Angle Filter	23	379	8	16 x 20	17.7
Short Bag/Side Loading Cartridge Filter	24	386	2 / 2	24 x 24 / 12 x 24	12.0
Long Bag/Side Loading Cartridge Filter	42	472	2 / 2	24 x 24 / 12 x 24	12.0
Bag/Front Loading Cartridge Filter	48	501	2 / 2	24 x 24 / 12 x 24	12.0
Blow-thru Front Loading HEPA Filter	48	501	2 / 2	24 x 24 / 12 x 24	12.0
HEAT TRANSFER SECTIONS	MIN AWL (in.)	MIN Weight (lb)	MAX AWL (in.)	MAX Weight (lb)	
Coil and Variable Length Plenum (with Drain Pan)	24	238	61	439	
Coil and Variable Length Plenum (without Drain Pan)	12	181	60	420	
Dual Coil and Variable Length Plenum (with Drain Pan)	30	238	61	439	
Vertical Coil				Future offering	
Multizone Front Discharge				Future offering	
Multizone Top Discharge				Future offering	
Internal Face and Bypass Cooling Coil	24	238	N/A	N/A	
Internal Face and Bypass Heating Coil	12	181	24	238	
Integral Face and Bypass Heating Coil	48	344	N/A	N/A	
Electric Heat with Control Box (Low Amp [min]/High Amp [max])	30	382	42	413	
Gas Heat (Low BTU [min]/High BTU [max])				Future offering	
AIR MOVEMENT SECTIONS*	MIN AWL (in.)†	MIN Weight (lb)†	MAX AWL (in.)**	MAX Weight (lb)**	
Airfoil Fan	53	1028	65	1056	
Downblast Airfoil Fan	53	1043	65	1093	
Forward Curved Fan	43	950	55	1003	
Belt-Drive Plenum Fan				Future offering	
Direct Drive Plenum Fan	41	600	51	907	
Fan Array				Future offering	
Vertical Forward Curve Fan				Future offering	
Vertical Airfoil Fan				Future offering	
Horizontal Direct Drive Plenum Fan with EC Motor				Variable depending upon fan size, quantity, and options. See AHUBuilder.	
MISCELLANEOUS SECTIONS	MIN AWL (in.)	MIN Weight (lb)	MAX AWL (in.)	MAX Weight (lb)	
ERV Section				Future offering	
Humidifier	24	378	48	486	
Access and Plenum	12	188	48	351	
Turning Plenum				Future offering	
Sound Attenuator	36	526	60	822	

* Refer to AHUBuilder® program for application specific weight and AWL.

† Minimum is based on smallest motor and smallest fan wheel combination.

** Maximum is based on largest motor and largest fan wheel combination.

Dimensions (cont)



Size 12W (6000 cfm)

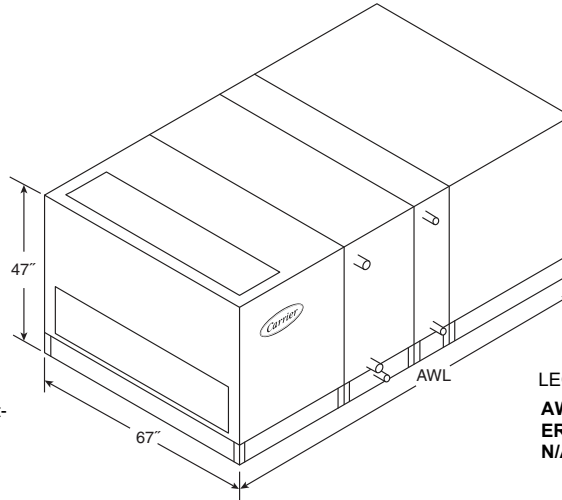

NOTES:

1. Dimensions are shown for indoor units. For outdoor units add 4 in. to height and 3 in. to width.
2. Height dimensions include 6-in. base rail.

LEGEND

- AWL** — Airway Length
- ERV** — Energy Recovery Ventilator
- N/A** — Not Applicable

AIR DISTRIBUTION COMPONENTS		AWL (in.)	Weight (lb)	DAMPER QUANTITY		
Mixing Box		21	227	1		
Side Inlet Mixing Box		33	293	1		
Filter Mixing Box (2-in. or 4-in. Flat Filter)		28	391	1		
Filter Mixing Box (6-in. Flat Filter)		30	406	1		
Filter Mixing Box (Angle Filter)		36	448	1		
Filter Mixing Box (Angle Filter) with Smoke Damper		42	541	1		
Filter Mixing Box (Bag Cartridge Filter)		41	484	1		
Air Mixer		24	303	N/A		
Exhaust Box		21	251	1		
Side Outlet Exhaust Box		33	305	1		
Combination Exhaust Mixing Box		33	250	1		
Internal Face and Bypass Damper		18	199	1		
External Face and Bypass Damper Section		21	425	1		
Multizone Damper (Front Discharge) (Two Deck)		5	132	N/A		
Multizone Damper (Top Discharge) (Two Deck)	5 (height)		132	N/A		
FILTRATION COMPONENTS		AWL (in.)	Weight (lb)	FILTER QUANTITY	FILTER SIZE (in.)	FILTER AREA (ft ²)
2-in. or 4-in. Flat Filter		12	309	6	16 x 20	13.3
2-in. Pre-Filter with 4-in. Flat Filter		14	318	6	16 x 20	13.3
2-in. or 4-in. Angle Filter		24	364	6	20 x 20	16.7
Short Bag/Side Loading Cartridge Filter		24	369	2 / 3	24 x 24 / 24 x 12	14.0
Long Bag/Side Loading Cartridge Filter		42	453	2 / 3	24 x 24 / 24 x 12	14.0
Bag/Front Loading Cartridge Filter		48	481	2 / 2	24 x 24 / 24 x 12	12.0
Blow-thru Front Loading HEPA Filter		48	481	2 / 2	24 x 24 / 24 x 12	12.0
HEAT TRANSFER SECTIONS		MIN AWL (in.)	MIN Weight (lb)	MAX AWL (in.)	MAX Weight (lb)	Zones
Coil and Variable Length Plenum (with Drain Pan)		24	227	61	423	
Coil and Variable Length Plenum (without Drain Pan)		12	171	60	409	
Dual Coil and Variable Length Plenum (with Drain Pan)		30	227	61	423	
Vertical Coil		42	325	N/A	N/A	
Multizone Front Discharge		61	913	N/A	N/A	10 zones
Multizone Top Discharge		61	840	N/A	N/A	10 zones
Internal Face and Bypass Cooling Coil		24	227	N/A	N/A	
Internal Face and Bypass Heating Coil		12	171	24	227	
Integral Face and Bypass Heating Coil		48	344	N/A	N/A	
Electric Heat with Control Box (Low Amp [min]/High Amp [max])		30	371	42	427	
Gas Heat (Low BTU [min]/High BTU [max])		85	947	121	1440	
AIR MOVEMENT SECTIONS*		MIN AWL (in.)†	MIN Weight (lb)†	MAX AWL (in.)**	MAX Weight (lb)**	
Airfoil Fan		34	929	40	1089	
Downblast Airfoil Fan		37	888	43	1104	
Forward Curved Fan		42	970	42	969	
Belt-Drive Plenum Fan		48	998	48	1141	
Direct Drive Plenum Fan		42	610	50	857	
Fan Array		40	648	43	864	
Vertical Forward Curve Fan		42	976	42	1020	
Vertical Airfoil Fan		42	968	42	1149	
Horizontal Direct Drive Plenum Fan with EC Motor						Variable depending upon fan size, quantity, and options. See AHUBuilder.
Vertical Direct Drive Plenum Fan with EC Motor						Variable depending upon fan size, quantity, and options. See AHUBuilder.
MISCELLANEOUS SECTIONS		MIN AWL (in.)	MIN Weight (lb)	MAX AWL (in.)	MAX Weight (lb)	
ERV Section		109	2815	131	3175	
Humidifier		24	382	48	493	
Access and Plenum		12	176	48	343	
Turning Plenum		24	262	N/A	N/A	
Sound Attenuator		36	472	60	718	

* Refer to AHUBuilder® program for application specific weight and AWL.

† Minimum is based on smallest motor and smallest fan wheel combination.

** Maximum is based on largest motor and largest fan wheel combination.

Dimensions (cont)



Size 14W (7000 cfm)

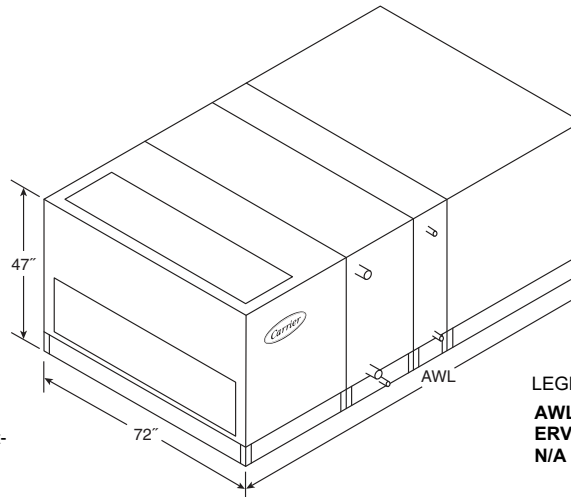

NOTES:

1. Dimensions are shown for indoor units. For outdoor units add 4 in. to height and 3 in. to width.
2. Height dimensions include 6-in. base rail.

LEGEND

- AWL** — Airway Length
- ERV** — Energy Recovery Ventilator
- N/A** — Not Applicable

AIR DISTRIBUTION COMPONENTS		AWL (in.)	Weight (lb)	DAMPER QUANTITY		
	Mixing Box	24	243	2		
	Side Inlet Mixing Box	39	332	1		
	Filter Mixing Box (2-in. or 4-in. Flat Filter)	31	431	2		
	Filter Mixing Box (6-in. Flat Filter)	33	446	2		
	Filter Mixing Box (Angle Filter)	36	468	2		
	Filter Mixing Box (Angle Filter) with Smoke Damper	44	582	1		
	Filter Mixing Box (Bag Cartridge Filter)	44	528	2		
	Air Mixer	24	318	N/A		
	Exhaust Box	24	274	2		
	Side Outlet Exhaust Box	39	346	1		
	Combination Exhaust Mixing Box	39	268	1		
	Internal Face and Bypass Damper	18	207	2		
	External Face and Bypass Damper Section	24	473	2		
	Multizone Damper (Front Discharge) (Two Deck)	5	146	N/A		
	Multizone Damper (Top Discharge) (Two Deck)	5 (height)	147	N/A		
FILTRATION COMPONENTS		AWL (in.)	Weight (lb)	FILTER QUANTITY	FILTER SIZE (in.)	FILTER AREA (ft ²)
	2-in. or 4-in. Flat Filter	12	330	3 / 3	16 x 20 / 20 x 20	15.0
	2-in. Pre-Filter with 4-in. Flat Filter	14	340	3 / 3	16 x 20 / 20 x 20	15.0
	2-in. or 4-in. Angle Filter	24	388	4 / 2	20 x 24 / 20 x 20	18.9
	Short Bag/Side Loading Cartridge Filter	24	393	2 / 3	24 x 24 / 24 x 12	14.0
	Long Bag/Side Loading Cartridge Filter	42	480	2 / 3	24 x 24 / 24 x 12	14.0
	Bag/Front Loading Cartridge Filter	48	509	2 / 3	24 x 24 / 24 x 12	14.0
	Blow-thru Front Loading HEPA Filter	48	509	2 / 3	24 x 24 / 24 x 12	14.0
HEAT TRANSFER SECTIONS		MIN AWL (in.)	MIN Weight (lb)	MAX AWL (in.)	MAX Weight (lb)	Zones
	Coil and Variable Length Plenum (with Drain Pan)	24	236	61	439	
	Coil and Variable Length Plenum (without Drain Pan)	12	178	60	424	
	Dual Coil and Variable Length Plenum (with Drain Pan)	30	236	61	439	
	Vertical Coil	48	360	N/A	N/A	
	Multizone Front Discharge	61	951	N/A	N/A	10 zones
	Multizone Top Discharge	61	872	N/A	N/A	10 zones
	Internal Face and Bypass Cooling Coil	24	236	N/A	N/A	
	Internal Face and Bypass Heating Coil	12	178	24	236	
	Integral Face and Bypass Heating Coil	48	357	N/A	N/A	
	Electric Heat with Control Box (Low Amp [min]/High Amp [max])	32	396	42	454	
	Gas Heat (Low BTU [min]/High BTU [max])	85	978	121	1594	
AIR MOVEMENT SECTIONS*		MIN AWL (in.)†	MIN Weight (lb)†	MAX AWL (in.)**	MAX Weight (lb)**	
	Airfoil Fan	34	984	46	1104	
	Downblast Airfoil Fan	37	999	49	1159	
	Forward Curved Fan	48	1055	48	1054	
	Belt-Drive Plenum Fan	48	1059	48	1202	
	Direct Drive Plenum Fan	46	662	51	913	
	Fan Array	38	705	43	885	
	Vertical Forward Curve Fan	48	1066	48	1110	
	Vertical Airfoil Fan	48	1114	48	1209	
	Horizontal Direct Drive Plenum Fan with EC Motor	Variable depending upon fan size, quantity, and options. See AHUBuilder.				
	Vertical Direct Drive Plenum Fan with EC Motor	Variable depending upon fan size, quantity, and options. See AHUBuilder.				
MISCELLANEOUS SECTIONS		MIN AWL (in.)	MIN Weight (lb)	MAX AWL (in.)	MAX Weight (lb)	
	ERV Section	115	3157	142	3524	
	Humidifier	24	403	48	519	
	Access and Plenum	12	183	48	356	
	Sound Attenuator	36	538	60	823	

* Refer to AHUBuilder® program for application specific weight and AWL.

† Minimum is based on smallest motor and smallest fan wheel combination.

** Maximum is based on largest motor and largest fan wheel combination.

Dimensions (cont)



Size 16T (8000 cfm)

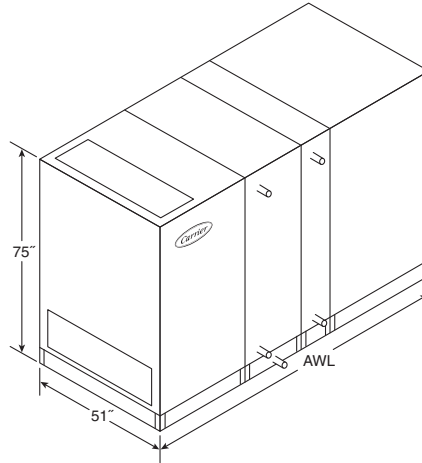

NOTES:

1. Dimensions are shown for indoor units. For outdoor units add 4 in. to height and 3 in. to width.
2. Height dimensions include 6-in. base rail.

LEGEND

- AWL** — Airway Length
- ERV** — Energy Recovery Ventilator
- N/A** — Not Applicable

AIR DISTRIBUTION COMPONENTS		AWL (in.)	Weight (lb)	DAMPER QUANTITY		
	Mixing Box	33	273	1		
	Side Inlet Mixing Box	27	367	2		
	Filter Mixing Box (2-in. or 4-in. Flat Filter)	40	502	1		
	Filter Mixing Box (6-in. Flat Filter)	42	517	1		
	Filter Mixing Box (Angle Filter)	41	509	1		
	Filter Mixing Box (Angle Filter) with Smoke Damper	55	683	1		
	Filter Mixing Box (Bag Cartridge Filter)	53	604	1		
	Air Mixer	24	363	N/A		
	Exhaust Box	33	308	1		
	Side Outlet Exhaust Box	27	380	2		
	Combination Exhaust Mixing Box	27	301	2		
	Internal Face and Bypass Damper	18	224	1		
	External Face and Bypass Damper Section				Future offering	
	Multizone Damper (Front Discharge) (Two Deck)				Future offering	
	Multizone Damper (Top Discharge) (Two Deck)				Future offering	
FILTRATION COMPONENTS		AWL (in.)	Weight (lb)	FILTER QUANTITY	FILTER SIZE (in.)	FILTER AREA (ft ²)
	2-in. or 4-in. Flat Filter	12	364	6	20 x 20	16.7
	2-in. Pre-Filter with 4-in. Flat Filter	14	374	6	20 x 20	16.7
	2-in. or 4-in. Angle Filter	26	424	8	20 x 20	22.2
	Short Bag/Side Loading Cartridge Filter	24	432	2 / 3	24 x 24 / 12 x 24	14.0
	Long Bag/Side Loading Cartridge Filter	42	523	2 / 3	24 x 24 / 12 x 24	14.0
	Bag/Front Loading Cartridge Filter	48	554	2 / 3	24 x 24 / 12 x 24	14.0
	Blow-thru Front Loading HEPA Filter	48	554	2 / 3	24 x 24 / 12 x 24	14.0
HEAT TRANSFER SECTIONS		MIN AWL (in.)	MIN Weight (lb)	MAX AWL (in.)	MAX Weight (lb)	
	Coil and Variable Length Plenum (with Drain Pan)	24	255	61	473	
	Coil and Variable Length Plenum (without Drain Pan)	12	194	60	450	
	Dual Coil and Variable Length Plenum (with Drain Pan)	30	255	61	473	
	Vertical Coil					Future offering
	Multizone Front Discharge					Future offering
	Multizone Top Discharge					Future offering
	Internal Face and Bypass Cooling Coil	24	255	N/A	N/A	
	Internal Face and Bypass Heating Coil	12	194	24	254	
	Integral Face and Bypass Heating Coil	48	920	N/A	N/A	
	Electric Heat with Control Box (Low Amp [min]/High Amp [max])	30	431	42	461	
	Gas Heat (Low BTU [min]/High BTU [max])					Future offering
AIR MOVEMENT SECTIONS*		MIN AWL (in.)†	MIN Weight (lb)†	MAX AWL (in.)**	MAX Weight (lb)**	
	Airfoil Fan	53	1125	61	1141	
	Downblast Airfoil Fan	56	1137	64	1253	
	Forward Curved Fan	49	1155	54	1164	
	Belt-Drive Plenum Fan					Future offering
	Direct Drive Plenum Fan	46	783	51	1068	
	Fan Array					Future offering
	Vertical Forward Curve Fan					Future offering
	Vertical Airfoil Fan					Future offering
	Horizontal Direct Drive Plenum Fan with EC Motor					Variable depending upon fan size, quantity, and options. See AHUBuilder.
MISCELLANEOUS SECTIONS		MIN AWL (in.)	MIN Weight (lb)	MAX AWL (in.)	MAX Weight (lb)	
	ERV Section					Future offering
	Humidifier	24	428	48	546	
	Access and Plenum	12	202	48	378	
	Turning Plenum	24	317	N/A	N/A	
	Sound Attenuator	36	597	60	933	

* Refer to AHUBuilder® program for application specific weight and AWL.
 † Minimum is based on smallest motor and smallest fan wheel combination.
 ** Maximum is based on largest motor and largest fan wheel combination.

Size 17W (8500 cfm)

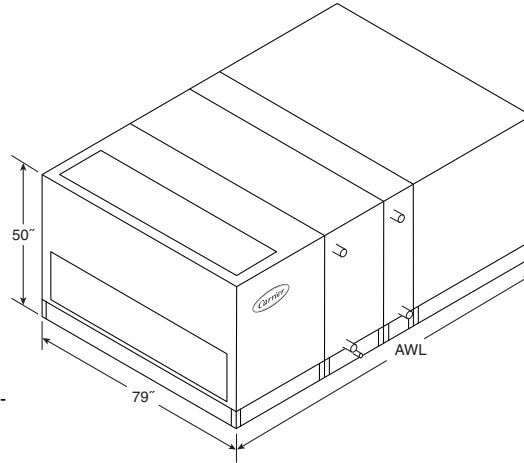

NOTES:

1. Dimensions are shown for indoor units. For outdoor units add 4 in. to height and 3 in. to width.
2. Height dimensions include 6-in. base rail.

LEGEND

- AWL** — Airway Length
- ERV** — Energy Recovery Ventilator
- N/A** — Not Applicable

AIR DISTRIBUTION COMPONENTS	AWL (in.)	Weight (lb)	DAMPER QUANTITY		
Mixing Box	24	264	2		
Side Inlet Mixing Box	39	360	2		
Filter Mixing Box (2-in. or 4-in. Flat Filter)	31	479	2		
Filter Mixing Box (6-in. Flat Filter)	33	495	2		
Filter Mixing Box (Angle Filter)	36	518	2		
Filter Mixing Box (Angle Filter) with Smoke Damper	44	644	1		
Filter Mixing Box (Bag Cartridge Filter)	44	582	2		
Air Mixer	30	380	N/A		
Exhaust Box	24	297	2		
Side Outlet Exhaust Box	39	375	2		
Combination Exhaust Mixing Box	39	291	2		
Internal Face and Bypass Damper	18	221	2		
External Face and Bypass Damper Section	24	534	2		
Multizone Damper (Front Discharge) (Two Deck)	5	168	N/A		
Multizone Damper (Top Discharge) (Two Deck)	5 (height)	168	N/A		
FILTRATION COMPONENTS	AWL (in.)	Weight (lb)	FILTER QUANTITY	FILTER SIZE (in.)	FILTER AREA (ft ²)
2-in. or 4-in. Flat Filter	12	364	6	20 x 20	16.7
2-in. Pre-Filter with 4-in. Flat Filter	14	375	6	20 x 20	16.7
2-in. or 4-in. Angle Filter	24	427	12	12 x 24	24.0
Short Bag/Side Loading Cartridge Filter	24	432	3 / 3	24 x 24 / 24 x 12	18.0
Long Bag/Side Loading Cartridge Filter	42	526	3 / 3	24 x 24 / 24 x 12	18.0
Bag/Front Loading Cartridge Filter	48	557	3 / 3	24 x 24 / 24 x 12	18.0
Blow-thru Front Loading HEPA Filter	48	557	3 / 3	24 x 24 / 24 x 12	18.0
HEAT TRANSFER SECTIONS	MIN AWL (in.)	MIN Weight (lb)	MAX AWL (in.)	MAX Weight (lb)	Zones
Coil and Variable Length Plenum (with Drain Pan)	24	252	61	471	
Coil and Variable Length Plenum (without Drain Pan)	12	189	60	454	
Dual Coil and Variable Length Plenum (with Drain Pan)	30	252	61	471	
Vertical Coil	48	389	N/A	N/A	
Multizone Front Discharge	61	1015	N/A	N/A	12 zones
Multizone Top Discharge	61	931	N/A	N/A	12 zones
Internal Face and Bypass Cooling Coil	24	252	N/A	N/A	
Internal Face and Bypass Heating Coil	12	189	24	252	
Integral Face and Bypass Heating Coil	48	382	N/A	N/A	
Electric Heat with Control Box (Low Amp [min]/High Amp [max])	32	438	42	500	
Gas Heat (Low BTU [min]/High BTU [max])	85	1075	121	1721	
AIR MOVEMENT SECTIONS*	MIN AWL (in.)†	MIN Weight (lb)†	MAX AWL (in.)**	MAX Weight (lb)**	
Airfoil Fan	46	1160	46	1237	
Downblast Airfoil Fan	49	1158	49	1253	
Forward Curved Fan	48	1277	48	1149	
Belt-Drive Plenum Fan	48	1207	48	1306	
Direct Drive Plenum Fan	49	812	57	1085	
Fan Array	39	788	46	1227	
Vertical Forward Curve Fan	48	1213	48	1214	
Vertical Airfoil Fan	48	1162	48	1312	
Horizontal Direct Drive Plenum Fan with EC Motor	Variable depending upon fan size, quantity, and options. See AHUBuilder.				
Vertical Direct Drive Plenum Fan with EC Motor	Variable depending upon fan size, quantity, and options. See AHUBuilder.				
MISCELLANEOUS SECTIONS	MIN AWL (in.)	MIN Weight (lb)	MAX AWL (in.)	MAX Weight (lb)	
ERV Section	121	3514	147	3929	
Humidifier	24	437	48	562	
Access and Plenum	12	195	48	382	
Turning Plenum	24	296	N/A	N/A	
Sound Attenuator	36	586	60	893	

* Refer to AHUBuilder® program for application specific weight and AWL.

† Minimum is based on smallest motor and smallest fan wheel combination.

** Maximum is based on largest motor and largest fan wheel combination.

Dimensions (cont)



Size 18T (9000 cfm)

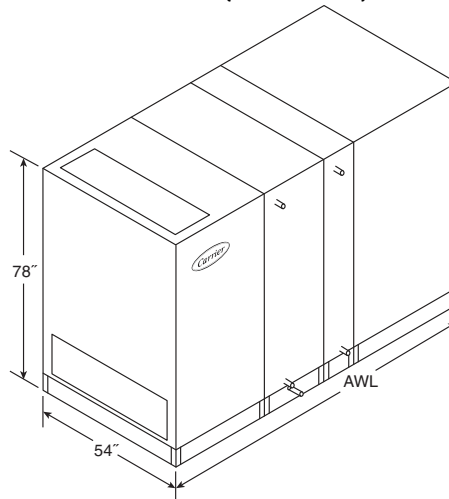

NOTES:

1. Dimensions are shown for indoor units. For outdoor units add 4 in. to height and 3 in. to width.
2. Height dimensions include 6-in. base rail.

LEGEND

- AWL** — Airway Length
- ERV** — Energy Recovery Ventilator
- N/A** — Not Applicable

AIR DISTRIBUTION COMPONENTS	AWL (in.)	Weight (lb)	DAMPER QUANTITY
Mixing Box	33	291	1
Side Inlet Mixing Box	27	391	2
Filter Mixing Box (2-in. or 4-in. Flat Filter)	40	539	1
Filter Mixing Box (6-in. Flat Filter)	42	556	1
Filter Mixing Box (Angle Filter)	41	547	1
Filter Mixing Box (Angle Filter) with Smoke Damper	55	726	1
Filter Mixing Box (Bag Cartridge Filter)	53	645	1
Air Mixer	30	390	N/A
Exhaust Box	33	328	1
Side Outlet Exhaust Box	27	404	2
Combination Exhaust/Mixing Box	27	321	2
Internal Face and Bypass Damper	18	232	2
External Face and Bypass Damper Section			Future offering
Multizone Damper (Front Discharge) (Two Deck)			Future offering
Multizone Damper (Top Discharge) (Two Deck)			Future offering

FILTRATION COMPONENTS	AWL (in.)	Weight (lb)	FILTER QUANTITY	FILTER SIZE (in.)	FILTER AREA (ft ²)
2-in. or 4-in. Flat Filter	12	385	6	20 x 25	20.8
2-in. Pre-Filter with 4-in. Flat Filter	14	395	6	20 x 25	20.8
2-in. or 4-in. Angle Filter	26	447	8	20 x 25	27.8
Short Bag/Side Loading Cartridge Filter	24	455	4 / 1	24 x 24 / 12 x 24	18.0
Long Bag/Side Loading Cartridge Filter	42	548	4 / 1	24 x 24 / 12 x 24	18.0
Bag/Front Loading Cartridge Filter	48	580	4 / 1	24 x 24 / 12 x 24	18.0
Blow-thru Front Loading HEPA Filter	48	580	4 / 1	24 x 24 / 12 x 24	18.0

HEAT TRANSFER SECTIONS	MIN AWL (in.)	MIN Weight (lb)	MAX AWL (in.)	MAX Weight (lb)
Coil and Variable Length Plenum (with Drain Pan)	24	263	61	489
Coil and Variable Length Plenum (without Drain Pan)	12	201	60	465
Dual Coil and Variable Length Plenum (with Drain Pan)	30	263	61	489
Vertical Coil				Future offering
Multizone Front Discharge				Future offering
Multizone Top Discharge				Future offering
Internal Face and Bypass Cooling Coil	24	263	N/A	N/A
Internal Face and Bypass Heating Coil	12	201	24	263
Integral Face and Bypass Heating Coil	48	988	N/A	N/A
Electric Heat with Control Box (Low Amp [min]/High Amp [max])	30	456	42	485
Gas Heat (Low BTU [min]/High BTU [max])				Future offering

AIR MOVEMENT SECTIONS*	MIN AWL (in.)†	MIN Weight (lb)†	MAX AWL (in.)**	MAX Weight (lb)**
Airfoil Fan	61	1204	64	1222
Downblast Airfoil Fan	64	1214	67	1334
Forward Curved Fan	49	1232	57	1244
Belt-Drive Plenum Fan				Future offering
Direct Drive Plenum Fan	49	853	57	1148
Fan Array				Future offering
Vertical Forward Curve Fan				Future offering
Vertical Airfoil Fan				Future offering
Horizontal Direct Drive Plenum Fan with EC Motor				Variable depending upon fan size, quantity, and options. See AHUBuilder.

MISCELLANEOUS SECTIONS	MIN AWL (in.)	MIN Weight (lb)	MAX AWL (in.)	MAX Weight (lb)
ERV Section				Future offering
Humidifier	24	453	48	576
Access and Plenum	12	453	48	392
Turning Plenum	24	333	N/A	N/A
Sound Attenuator	36	619	60	971

* Refer to AHUBuilder® program for application specific weight and AWL.

† Minimum is based on smallest motor and smallest fan wheel combination.

** Maximum is based on largest motor and largest fan wheel combination.

Size 21W (10,500 cfm)

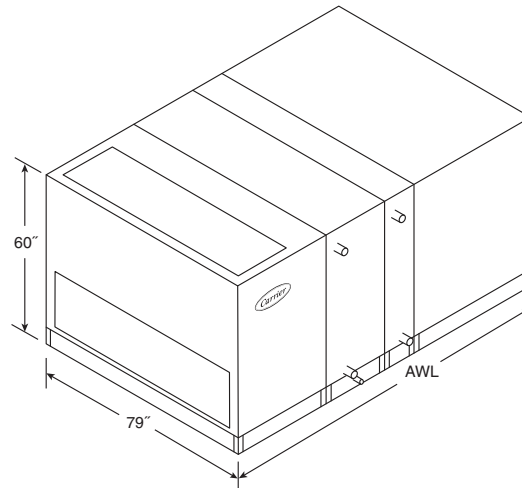

NOTES:

1. Dimensions are shown for indoor units. For outdoor units add 4 in. to height and 3 in. to width.
2. Height dimensions include 6-in. base rail.

LEGEND

- AWL** — Airway Length
- ERV** — Energy Recovery Ventilator
- N/A** — Not Applicable

AIR DISTRIBUTION COMPONENTS	AWL (in.)	Weight (lb)	DAMPER QUANTITY		
Mixing Box	27	301	2		
Side Inlet Mixing Box	39	388	2		
Filter Mixing Box (2-in. or 4-in. Flat Filter)	34	559	2		
Filter Mixing Box (6-in. Flat Filter)	36	575	2		
Filter Mixing Box (Angle Filter)	38	575	2		
Filter Mixing Box (Angle Filter) with Smoke Damper	47	737	1		
Filter Mixing Box (Bag Cartridge Filter)	47	668	2		
Air Mixer	30	418	N/A		
Exhaust Box	27	335	2		
Side Outlet Exhaust Box	39	400	2		
Combination Exhaust Mixing Box	39	332	2		
Internal Face and Bypass Damper	18	233	2		
External Face and Bypass Damper Section	27	624	2		
Multizone Damper (Front Discharge) (Two Deck)	5	197	N/A		
Multizone Damper (Top Discharge) (Two Deck)	5 (height)	196	N/A		
FILTRATION COMPONENTS	AWL (in.)	Weight (lb)	FILTER QUANTITY	FILTER SIZE (in.)	FILTER AREA (ft ²)
2-in. or 4-in. Flat Filter	12	406	6	20 x 25	20.8
2-in. Pre-Filter with 4-in. Flat Filter	14	417	6	20 x 25	20.8
2-in. or 4-in. Angle Filter	24	471	12	16 x 25	33.3
Short Bag/Side Loading Cartridge Filter	24	478	6	24 x 24	24.0
Long Bag/Side Loading Cartridge Filter	42	579	6	24 x 24	24.0
Bag/Front Loading Cartridge Filter	48	612	6	24 x 24	24.0
Blow-thru Front Loading HEPA Filter	48	612	6	24 x 24	24.0
HEAT TRANSFER SECTIONS	MIN AWL (in.)	MIN Weight (lb)	MAX AWL (in.)	MAX Weight (lb)	Zones
Coil and Variable Length Plenum (with Drain Pan)	24	266	61	498	
Coil and Variable Length Plenum (without Drain Pan)	12	199	60	481	
Dual Coil and Variable Length Plenum (with Drain Pan)	30	266	61	498	
Vertical Coil	48	425	N/A	N/A	
Multizone Front Discharge	73	1191	N/A	N/A	12 zones
Multizone Top Discharge	73	1087	N/A	N/A	12 zones
Internal Face and Bypass Cooling Coil	24	266	N/A	N/A	
Internal Face and Bypass Heating Coil	12	199	24	266	
Integral Face and Bypass Heating Coil	48	406	N/A	N/A	
Electric Heat with Control Box (Low Amp [min]/High Amp [max])	30	485	30	485	
Gas Heat (Low BTU [min]/High BTU [max])	91	1235	127	1904	
AIR MOVEMENT SECTIONS*	MIN AWL (in.)†	MIN Weight (lb)†	MAX AWL (in.)**	MAX Weight (lb)**	
Airfoil Fan	46	1277	48	1472	
Downblast Airfoil Fan	49	1402	51	1489	
Forward Curved Fan	48	1365	48	1395	
Belt-Drive Plenum Fan	48	1339	54	1577	
Direct Drive Plenum Fan	51	1014	61	1391	
Fan Array	42	881	46	1279	
Vertical Forward Curve Fan	48	1474	48	1474	
Vertical Airfoil Fan	48	1346	48	1550	
Horizontal Direct Drive Plenum Fan with EC Motor			Variable depending upon fan size, quantity, and options. See AHUBuilder.		
Vertical Direct Drive Plenum Fan with EC Motor			Variable depending upon fan size, quantity, and options. See AHUBuilder.		
MISCELLANEOUS SECTIONS	MIN AWL (in.)	MIN Weight (lb)	MAX AWL (in.)	MAX Weight (lb)	
ERV Section	121	3871	147	4411	
Humidifier	24	476	48	609	
Access and Plenum	12	205	48	405	
Turning Plenum	30	351	N/A	N/A	
Sound Attenuator	36	708	60	1092	

* Refer to **AHUBuilder**® program for application specific weight and AWL.
 † Minimum is based on smallest motor and smallest fan wheel combination.
 ** Maximum is based on largest motor and largest fan wheel combination.

Dimensions (cont)



Size 22T (11,000 cfm)

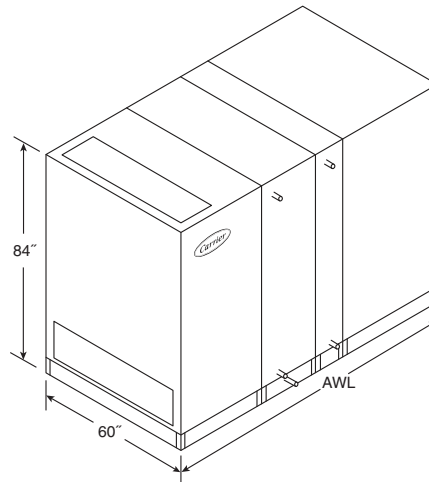

NOTES:

1. Dimensions are shown for indoor units. For outdoor units add 4 in. to height and 3 in. to width.
2. Height dimensions include 6-in. base rail.

LEGEND

- AWL** — Airway Length
- ERV** — Energy Recovery Ventilator
- N/A** — Not Applicable

AIR DISTRIBUTION COMPONENTS	AWL (in.)	Weight (lb)	DAMPER QUANTITY		
Mixing Box	39	327	2		
Side Inlet Mixing Box	33	437	2		
Filter Mixing Box (2-in. or 4-in. Flat Filter)	46	607	2		
Filter Mixing Box (6-in. Flat Filter)	48	624	2		
Filter Mixing Box (Angle Filter)	48	624	2		
Filter Mixing Box (Angle Filter) with Smoke Damper	58	834	1		
Filter Mixing Box (Bag Cartridge Filter)	59	721	2		
Air Mixer	30	444	N/A		
Exhaust Box	39	370	2		
Side Outlet Exhaust Box	33	450	2		
Combination Exhaust Mixing Box	33	360	2		
Internal Face and Bypass Damper	18	247	2		
External Face and Bypass Damper Section				Future offering	
Multizone Damper (Front Discharge) (Two Deck)				Future offering	
Multizone Damper (Top Discharge) (Two Deck)				Future offering	
FILTRATION COMPONENTS	AWL (in.)	Weight (lb)	FILTER QUANTITY	FILTER SIZE (in.)	FILTER AREA (ft ²)
2-in. or 4-in. Flat Filter	12	425	2 / 6	20 x 25 / 16 x 25	23.6
2-in. Pre-Filter with 4-in. Flat Filter	14	436	2 / 6	20 x 25 / 16 x 25	23.6
2-in. or 4-in. Angle Filter	23	493	12	16 x 25	33.3
Short Bag/Side Loading Cartridge Filter	24	500	6	24 x 24	24.0
Long Bag/Side Loading Cartridge Filter	42	599	6	24 x 24	24.0
Bag/Front Loading Cartridge Filter	48	633	6	24 x 24	24.0
Blow-thru Front Loading HEPA Filter	48	633	4 / 2	24 x 24 / 12 x 24	20.0
HEAT TRANSFER SECTIONS	MIN AWL (in.)	MIN Weight (lb)	MAX AWL (in.)	MAX Weight (lb)	
Coil and Variable Length Plenum (with Drain Pan)	24	280	61	522	
Coil and Variable Length Plenum (without Drain Pan)	12	213	60	495	
Dual Coil and Variable Length Plenum (with Drain Pan)	30	280	61	522	
Vertical Coil					Future offering
Multizone Front Discharge					Future offering
Multizone Top Discharge					Future offering
Internal Face and Bypass Cooling Coil	24	280	N/A	N/A	
Internal Face and Bypass Heating Coil	12	213	24	279	
Integral Face and Bypass Heating Coil	48	460	N/A	N/A	
Electric Heat with Control Box (Low Amp [min]/High Amp [max])	30	506	42	532	
Gas Heat (Low BTU [min]/High BTU [max])					Future offering
AIR MOVEMENT SECTIONS*	MIN AWL (in.)†	MIN Weight (lb)†	MAX AWL (in.)**	MAX Weight (lb)**	
Airfoil Fan	64	1362	66	1385	
Downblast Airfoil Fan	67	1368	72	1494	
Forward Curved Fan	49	1387	64	1405	
Belt-Drive Plenum Fan					Future offering
Direct Drive Plenum Fan	51	995	61	1308	
Fan Array					Future offering
Vertical Forward Curve Fan					Future offering
Vertical Airfoil Fan					Future offering
Horizontal Direct Drive Plenum Fan with EC Motor					Variable depending upon fan size, quantity, and options. See AHUBuilder.
MISCELLANEOUS SECTIONS	MIN AWL (in.)	MIN Weight (lb)	MAX AWL (in.)	MAX Weight (lb)	
ERV Section					Future offering
Humidifier	24	502	48	636	
Access and Plenum	12	502	48	419	
Turning Plenum	30	366	N/A	N/A	
Sound Attenuator	36	689	60	1094	

* Refer to AHUBuilder® program for application specific weight and AWL.

† Minimum is based on smallest motor and smallest fan wheel combination.

** Maximum is based on largest motor and largest fan wheel combination.

Dimensions (cont)



Size 25W (12,500 cfm)

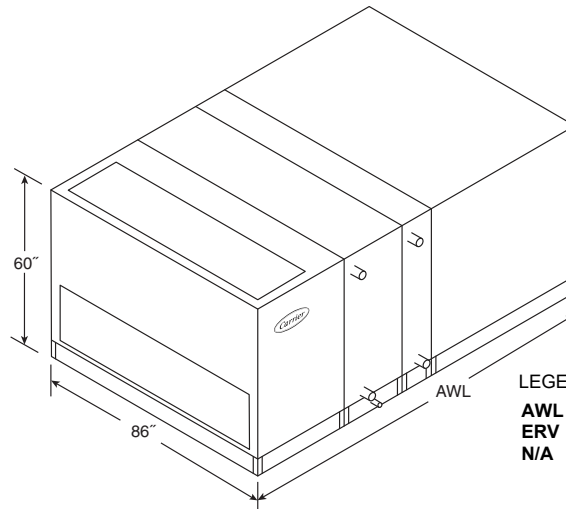

NOTES:

1. Dimensions are shown for indoor units. For outdoor units add 4 in. to height and 3 in. to width.
2. Height dimensions include 6-in. base rail.

LEGEND

- AWL** — Airway Length
- ERV** — Energy Recovery Ventilator
- N/A** — Not Applicable

AIR DISTRIBUTION COMPONENTS	AWL (in.)	Weight (lb)	DAMPER QUANTITY		
Mixing Box	27	315	2		
Side Inlet Mixing Box	45	439	2		
Filter Mixing Box (2-in. or 4-in. Flat Filter)	34	605	2		
Filter Mixing Box (6-in. Flat Filter)	36	622	2		
Filter Mixing Box (Angle Filter)	36	622	2		
Filter Mixing Box (Angle Filter) with Smoke Damper	47	801	1		
Filter Mixing Box (Bag Cartridge Filter)	47	719	2		
Air Mixer	30	445	N/A		
Exhaust Box	27	357	2		
Side Outlet Exhaust Box	45	457	2		
Combination Exhaust Mixing Box	45	347	2		
Internal Face and Bypass Damper	18	243	2		
External Face and Bypass Damper Section	27	697	2		
Multizone Damper (Front Discharge) (Two Deck)	5	224	N/A		
Multizone Damper (Top Discharge) (Two Deck)	5 (height)	224	N/A		
FILTRATION COMPONENTS	AWL (in.)	Weight (lb)	FILTER QUANTITY	FILTER SIZE (in.)	FILTER AREA (ft ²)
2-in. or 4-in. Flat Filter	12	444	8	24 x 20	26.7
2-in. Pre-Filter with 4-in. Flat Filter	14	456	8	24 x 20	26.7
2-in. or 4-in. Angle Filter	24	514	12	16 x 25	33.3
Short Bag/Side Loading Cartridge Filter	24	520	6	24 x 24	24.0
Long Bag/Side Loading Cartridge Filter	42	625	6	24 x 24	24.0
Bag/Front Loading Cartridge Filter	48	660	6	24 x 24	24.0
Blow-thru Front Loading HEPA Filter	48	660	6	24 x 24	24.0
HEAT TRANSFER SECTIONS	MIN AWL (in.)	MIN Weight (lb)	MAX AWL (in.)	MAX Weight (lb)	Zones
Coil and Variable Length Plenum (with Drain Pan)	24	278	61	521	
Coil and Variable Length Plenum (without Drain Pan)	12	208	60	502	
Dual Coil and Variable Length Plenum (with Drain Pan)	30	278	61	521	
Vertical Coil	60	520	N/A	N/A	
Multizone Front Discharge	73	1252	N/A	N/A	13 zones
Multizone Top Discharge	73	1137	N/A	N/A	13 zones
Internal Face and Bypass Cooling Coil	24	278	N/A	N/A	
Internal Face and Bypass Heating Coil	12	208	24	278	
Integral Face and Bypass Heating Coil	48	424	N/A	N/A	
Electric Heat with Control Box (Low Amp [min]/High Amp [max])	30	528	30	528	
Gas Heat (Low BTU [min]/High BTU [max])	91	1282	127	1965	
AIR MOVEMENT SECTIONS*	MIN AWL (in.)†	MIN Weight (lb)†	MAX AWL (in.)**	MAX Weight (lb)**	
Airfoil Fan	46	1460	58	1677	
Downblast Airfoil Fan	49	1508	61	1712	
Forward Curved Fan	60	1586	60	1586	
Belt-Drive Plenum Fan	54	1486	54	1689	
Direct Drive Plenum Fan	54	1123	65	1632	
Fan Array	44	951	50	1424	
Vertical Forward Curve Fan	60	1536	60	1664	
Vertical Airfoil Fan	60	1538	60	1781	
Horizontal Direct Drive Plenum Fan with EC Motor	Variable depending upon fan size, quantity, and options. See AHUBuilder.				
MISCELLANEOUS SECTIONS	MIN AWL (in.)	MIN Weight (lb)	MAX AWL (in.)	MAX Weight (lb)	
ERV Section	138	4483	170	5113	
Humidifier	24	512	48	652	
Access and Plenum	12	214	48	423	
Turning Plenum	30	369	N/A	N/A	
Sound Attenuator	36	752	60	1158	

* Refer to AHUBuilder® program for application specific weight and AWL.

† Minimum is based on smallest motor and smallest fan wheel combination.

** Maximum is based on largest motor and largest fan wheel combination.

Dimensions (cont)



Size 25T (12,500 cfm)

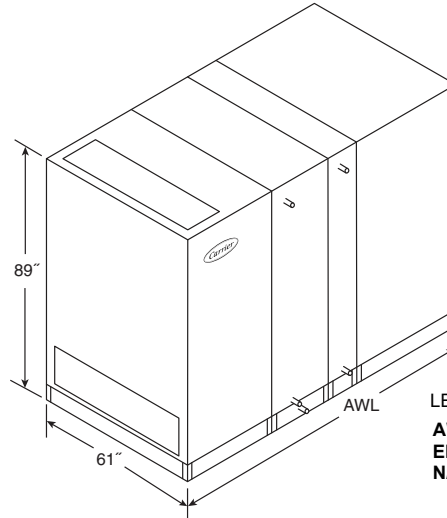

NOTES:

1. Dimensions are shown for indoor units. For outdoor units add 4 in. to height and 3 in. to width.
2. Height dimensions include 6-in. base rail.

LEGEND

- AWL** — Airway Length
- ERV** — Energy Recovery Ventilator
- N/A** — Not Applicable

AIR DISTRIBUTION COMPONENTS	AWL (in.)	Weight (lb)	DAMPER QUANTITY		
Mixing Box	45	354	2		
Side Inlet Mixing Box	33	473	3		
Filter Mixing Box (2-in. or 4-in. Flat Filter)	52	672	2		
Filter Mixing Box (6-in. Flat Filter)	54	691	2		
Filter Mixing Box (Angle Filter)	53	681	2		
Filter Mixing Box (Angle Filter) with Smoke Damper	71	973	1		
Filter Mixing Box (Bag Cartridge Filter)	65	791	2		
Air Mixer	30	485	N/A		
Exhaust Box	45	400	2		
Side Outlet Exhaust Box	33	484	3		
Combination Exhaust Mixing Box	33	390	3		
Internal Face and Bypass Damper	18	258	2		
External Face and Bypass Damper Section				Future offering	
Multizone Damper (Front Discharge) (Two Deck)				Future offering	
Multizone Damper (Top Discharge) (Two Deck)				Future offering	
FILTRATION COMPONENTS	AWL (in.)	Weight (lb)	FILTER QUANTITY	FILTER SIZE (in.)	FILTER AREA (ft ²)
2-in. or 4-in. Flat Filter	12	456	2 / 6	16 x 25 / 20 x 25	26.4
2-in. Pre-Filter with 4-in. Flat Filter	14	467	2 / 6	16 x 25 / 20 x 25	26.4
2-in. or 4-in. Angle Filter	30	527	12	25 x 16	33.3
Short Bag/Side Loading Cartridge Filter	24	534	6	24 x 24	24.0
Long Bag/Side Loading Cartridge Filter	42	638	6	24 x 24	24.0
Bag/Front Loading Cartridge Filter	48	673	6	24 x 24	24.0
Blow-thru Front Loading HEPA Filter	48	673	6	24 x 24	24.0
HEAT TRANSFER SECTIONS	MIN AWL (in.)	MIN Weight (lb)	MAX AWL (in.)	MAX Weight (lb)	
Coil and Variable Length Plenum (with Drain Pan)	24	293	61	547	
Coil and Variable Length Plenum (without Drain Pan)	12	223	60	518	
Dual Coil and Variable Length Plenum (with Drain Pan)	30	293	61	547	
Vertical Coil					Future offering
Multizone Front Discharge					Future offering
Multizone Top Discharge					Future offering
Internal Face and Bypass Cooling Coil	24	293	N/A	N/A	
Internal Face and Bypass Heating Coil	12	223	24	292	
Integral Face and Bypass Heating Coil	48	500	N/A	N/A	
Electric Heat with Control Box (Low Amp [min]/High Amp [max])	30	543	42	568	
Gas Heat (Low BTU [min]/High BTU [max])					Future offering
AIR MOVEMENT SECTIONS*	MIN AWL (in.)†	MIN Weight (lb)†	MAX AWL (in.)**	MAX Weight (lb)**	
Airfoil Fan	66	1408	68	1506	
Downblast Airfoil Fan	72	1483	74	1615	
Forward Curved Fan	58	1504	64	1526	
Belt-Drive Plenum Fan					Future offering
Direct Drive Plenum Fan	54	1101	65	1429	
Fan Array					Future offering
Vertical Forward Curve Fan					Future offering
Vertical Airfoil Fan					Future offering
Horizontal Direct Drive Plenum Fan with EC Motor					Variable depending upon fan size, quantity, and options. See AHUBuilder.
Vertical Direct Drive Plenum Fan with EC Motor					Variable depending upon fan size, quantity, and options. See AHUBuilder.
MISCELLANEOUS SECTIONS	MIN AWL (in.)	MIN Weight (lb)	MAX AWL (in.)	MAX Weight (lb)	
ERV Section					Future offering
Humidifier	24	539	48	681	
Access and Plenum	12	539	48	439	
Turning Plenum	30	391	N/A	N/A	
Sound Attenuator	36	711	60	1137	

* Refer to **AHUBuilder**® program for application specific weight and AWL.
 † Minimum is based on smallest motor and smallest fan wheel combination.
 ** Maximum is based on largest motor and largest fan wheel combination.

Size 30W (15,000 cfm)

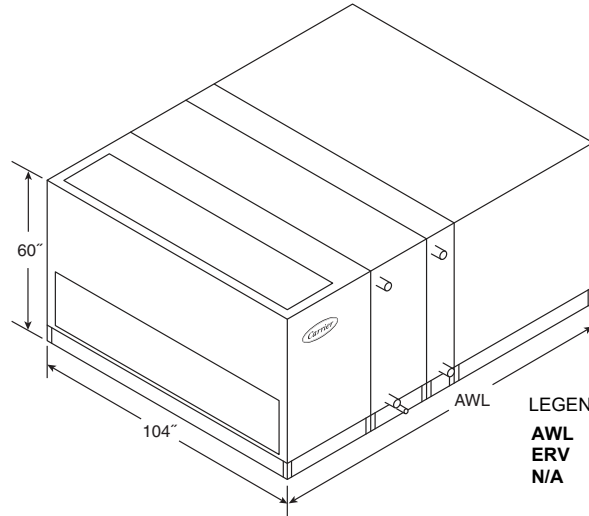

NOTES:

1. Dimensions are shown for indoor units. For outdoor units add 4 in. to height and 3 in. to width.
2. Height dimensions include 6-in. base rail.

AIR DISTRIBUTION COMPONENTS		AWL (in.)	Weight (lb)	DAMPER QUANTITY		
Mixing Box		27	409	2		
Side Inlet Mixing Box		51	601	2		
Filter Mixing Box (2-in. or 4-in. Flat Filter)		34	744	2		
Filter Mixing Box (6-in. Flat Filter)		36	766	2		
Filter Mixing Box (Angle Filter)		36	766	2		
Filter Mixing Box (Angle Filter) with Smoke Damper		47	976	1		
Filter Mixing Box (Bag Cartridge Filter)		47	890	2		
Air Mixer		36	606	N/A		
Exhaust Box		27	455	2		
Side Outlet Exhaust Box		51	618	2		
Combination Exhaust Mixing Box		51	450	2		
Internal Face and Bypass Damper		18	323	2		
External Face and Bypass Damper Section		27	858	2		
Multizone Damper (Front Discharge) (Two Deck)		5	260	N/A		
Multizone Damper (Top Discharge) (Two Deck)		5 (height)	260	N/A		
FILTRATION COMPONENTS		AWL (in.)	Weight (lb)	FILTER QUANTITY	FILTER SIZE (in.)	FILTER AREA (ft ²)
2-in. or 4-in. Flat Filter		12	555	10	24 x 20	33.3
2-in. Pre-Filter with 4-in. Flat Filter		14	568	10	24 x 20	33.3
2-in. or 4-in. Angle Filter		24	638	16	16 x 25	44.4
Short Bag/Side Loading Cartridge Filter		24	645	8	24 x 24	32.0
Long Bag/Side Loading Cartridge Filter		42	770	8	24 x 24	32.0
Bag/Front Loading Cartridge Filter		48	811	8	24 x 24	32.0
Blow-thru Front Loading HEPA Filter		48	811	8	24 x 24	32.0
HEAT TRANSFER SECTIONS		MIN AWL (in.)	MIN Weight (lb)	MAX AWL (in.)	MAX Weight (lb)	Zones
Coil and Variable Length Plenum (with Drain Pan)		24	365	61	675	
Coil and Variable Length Plenum (without Drain Pan)		12	282	60	628	
Dual Coil and Variable Length Plenum (with Drain Pan)		30	365	61	675	
Vertical Coil		60	672	N/A	N/A	
Multizone Front Discharge		73	1528	N/A	N/A	16 zones
Multizone Top Discharge		73	1389	N/A	N/A	16 zones
Internal Face and Bypass Cooling Coil		24	365	N/A	N/A	
Internal Face and Bypass Heating Coil		12	282	24	364	
Integral Face and Bypass Heating Coil		48	537	N/A	N/A	
Electric Heat with Control Box (Low Amp [min]/High Amp [max])		30	661	30	661	
Gas Heat (Low BTU [min]/High BTU [max])		97	1440	163	3365	
AIR MOVEMENT SECTIONS*		MIN AWL (in.)†	MIN Weight (lb)†	MAX AWL (in.)**	MAX Weight (lb)**	
Airfoil Fan		58	1770	58	1923	
Downblast Airfoil Fan		61	1841	61	1864	
Forward Curved Fan		60	1799	60	1799	
Belt-Drive Plenum Fan		54	1739	54	1984	
Direct Drive Plenum Fan		54	1273	69	1844	
Fan Array		44	1180	50	1572	
Vertical Forward Curve Fan		60	1912	60	1942	
Vertical Airfoil Fan		60	1942	60	2065	
Horizontal Direct Drive Plenum Fan with EC Motor		Variable depending upon fan size, quantity, and options. See AHUBuilder.				
MISCELLANEOUS SECTIONS		MIN AWL (in.)	MIN Weight (lb)	MAX AWL (in.)	MAX Weight (lb)	
ERV Section		138	5388	179	6156	
Humidifier		24	630	48	796	
Access and Plenum		12	289	48	537	
Turning Plenum		30	473	N/A	N/A	
Sound Attenuator		36	1037	60	1560	

* Refer to AHUBuilder® program for application specific weight and AWL.

† Minimum is based on smallest motor and smallest fan wheel combination.

** Maximum is based on largest motor and largest fan wheel combination.

Size 30T (15,000 cfm)

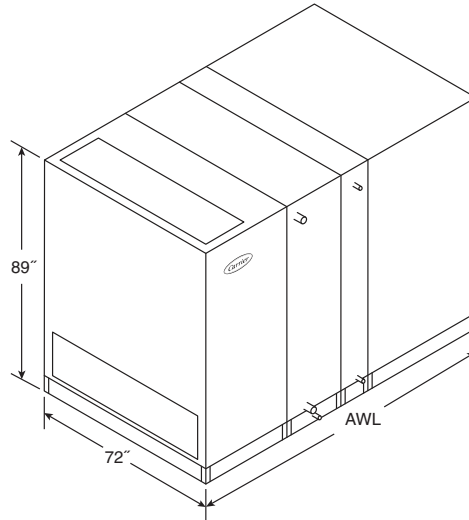

NOTES:

1. Dimensions are shown for indoor units. For outdoor units add 4 in. to height and 3 in. to width.
2. Height dimensions include 6-in. base rail.

LEGEND

- AWL** — Airway Length
- ERV** — Energy Recovery Ventilator
- N/A** — Not Applicable

AIR DISTRIBUTION COMPONENTS		AWL (in.)	Weight (lb)	DAMPER QUANTITY		
	Mixing Box	45	399	2		
	Side Inlet Mixing Box	39	531	3		
	Filter Mixing Box (2-in. or 4-in. Flat Filter)	52	767	2		
	Filter Mixing Box (6-in. Flat Filter)	54	786	2		
	Filter Mixing Box (Angle Filter)	53	776	2		
	Filter Mixing Box (Angle Filter) with Smoke Damper	71	1132	1		
	Filter Mixing Box (Bag Cartridge Filter)	65	895	2		
	Air Mixer	36	553	N/A		
	Exhaust Box	45	452	2		
	Side Outlet Exhaust Box	39	542	3		
	Combination Exhaust Mixing Box	39	439	3		
	Internal Face and Bypass Damper	18	276	2		
	External Face and Bypass Damper Section				Future offering	
	Multizone Damper (Front Discharge) (Two Deck)				Future offering	
	Multizone Damper (Top Discharge) (Two Deck)				Future offering	
FILTRATION COMPONENTS		AWL (in.)	Weight (lb)	FILTER QUANTITY	FILTER SIZE (in.)	FILTER AREA (ft ²)
	2-in. or 4-in. Flat Filter	12	506	9	24 x 20	30.0
	2-in. Pre-Filter with 4-in. Flat Filter	14	519	9	24 x 20	30.0
	2-in. or 4-in. Angle Filter	30	584	16	25 x 16	44.4
	Short Bag/Side Loading Cartridge Filter	24	591	6 / 3	24 x 24 / 12 x 24	30.0
	Long Bag/Side Loading Cartridge Filter	42	702	6 / 3	24 x 24 / 12 x 24	30.0
	Bag/Front Loading Cartridge Filter	48	739	6 / 3	24 x 24 / 12 x 24	30.0
	Blow-thru Front Loading HEPA Filter	48	739	6 / 3	24 x 24 / 12 x 24	30.0
HEAT TRANSFER SECTIONS		MIN AWL (in.)	MIN Weight (lb)	MAX AWL (in.)	MAX Weight (lb)	
	Coil and Variable Length Plenum (with Drain Pan)	24	314	61	589	
	Coil and Variable Length Plenum (without Drain Pan)	12	239	60	555	
	Dual Coil and Variable Length Plenum (with Drain Pan)	30	314	61	589	
	Vertical Coil					Future offering
	Multizone Front Discharge					Future offering
	Multizone Top Discharge					Future offering
	Internal Face and Bypass Cooling Coil	24	314	N/A	N/A	
	Internal Face and Bypass Heating Coil	12	239	24	313	
	Integral Face and Bypass Heating Coil	48	507	N/A	N/A	
	Electric Heat with Control Box (Low Amp [min]/High Amp [max])	30	605	42	628	
	Gas Heat (Low BTU [min]/High BTU [max])					Future offering
AIR MOVEMENT SECTIONS*		MIN AWL (in.)†	MIN Weight (lb)†	MAX AWL (in.)**	MAX Weight (lb)**	
	Airfoil Fan	66	1677	72	1710	
	Downblast Airfoil Fan	72	1676	77	1815	
	Forward Curved Fan	59	1698	59	1727	
	Belt-Drive Plenum Fan					Future offering
	Direct Drive Plenum Fan	54	1278	65	1630	
	Fan Array					Future offering
	Vertical Forward Curve Fan					Future offering
	Vertical Airfoil Fan					Future offering
	Horizontal Direct Drive Plenum Fan with EC Motor					Variable depending upon fan size, quantity, and options. See AHUBuilder.
	Vertical Direct Drive Plenum Fan with EC Motor					Variable depending upon fan size, quantity, and options. See AHUBuilder.
MISCELLANEOUS SECTIONS		MIN AWL (in.)	MIN Weight (lb)	MAX AWL (in.)	MAX Weight (lb)	
	ERV Section					Future offering
	Humidifier	24	601	48	756	
	Access and Plenum	12	601	48	473	
	Turning Plenum	N/A	432	N/A	N/A	
	Sound Attenuator	36	965	60	1488	

* Refer to AHUBuilder® program for application specific weight and AWL.

† Minimum is based on smallest motor and smallest fan wheel combination.

** Maximum is based on largest motor and largest fan wheel combination.

Size 35T (18,000 cfm)

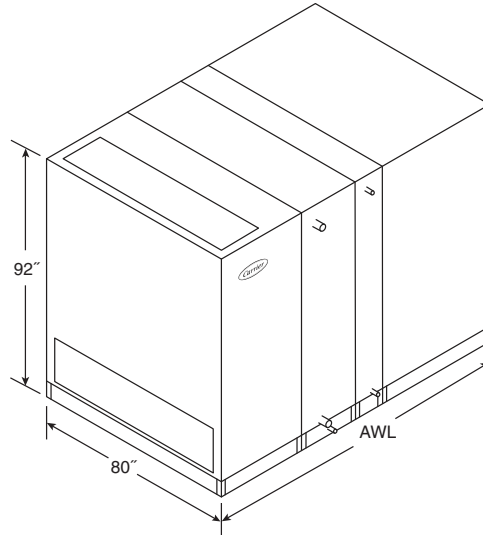

NOTES:

1. Dimensions are shown for indoor units. For outdoor units add 4 in. to height and 3 in. to width.
2. Height dimensions include 6-in. base rail.

LEGEND

- AWL** — Airway Length
- ERV** — Energy Recovery Ventilator
- N/A** — Not Applicable

AIR DISTRIBUTION COMPONENTS	AWL (in.)	Weight (lb)	DAMPER QUANTITY		
Mixing Box	45	444	2		
Side Inlet Mixing Box	39	590	3		
Filter Mixing Box (2-in. or 4-in. Flat Filter)	52	862	2		
Filter Mixing Box (6-in. Flat Filter)	54	883	2		
Filter Mixing Box (Angle Filter)	53	872	2		
Filter Mixing Box (Angle Filter) with Smoke Damper	64	1185	1		
Filter Mixing Box (Bag Cartridge Filter)	65	999	2		
Air Mixer	36	621	N/A		
Exhaust Box	45	503	2		
Side Outlet Exhaust Box	45	600	3		
Combination Exhaust Mixing Box	45	489	3		
Internal Face and Bypass Damper	18	295	2		
External Face and Bypass Damper Section				Future offering	
Multizone Damper (Front Discharge) (Two Deck)				Future offering	
Multizone Damper (Top Discharge) (Two Deck)				Future offering	
FILTRATION COMPONENTS	AWL (in.)	Weight (lb)	FILTER QUANTITY	FILTER SIZE (in.)	FILTER AREA (ft ²)
2-in. or 4-in. Flat Filter	12	557	3 / 9	16 x 25 x 20 x 25	39.6
2-in. Pre-Filter with 4-in. Flat Filter	14	570	3 / 9	16 x 25 x 20 x 25	39.6
2-in. or 4-in. Angle Filter	23	640	18	16 x 25	50.0
Short Bag/Side Loading Cartridge Filter	24	648	9	24 x 24	36.0
Long Bag/Side Loading Cartridge Filter	42	765	9	24 x 24	36.0
Bag/Front Loading Cartridge Filter	48	805	9	24 x 24	36.0
Blow-thru Front Loading HEPA Filter	48	805	9	24 x 24	36.0
HEAT TRANSFER SECTIONS	MIN AWL (in.)	MIN Weight (lb)	MAX AWL (in.)	MAX Weight (lb)	
Coil and Variable Length Plenum (with Drain Pan)	24	336	61	630	
Coil and Variable Length Plenum (without Drain Pan)	12	256	60	593	
Dual Coil and Variable Length Plenum (with Drain Pan)	30	336	61	630	
Vertical Coil					Future offering
Multizone Front Discharge					Future offering
Multizone Top Discharge					Future offering
Internal Face and Bypass Cooling Coil	24	336	N/A	N/A	
Internal Face and Bypass Heating Coil	12	256	24	334	
Integral Face and Bypass Heating Coil					Future offering
Electric Heat with Control Box (Low Amp [min]/High Amp [max])	30	667	42	687	
Gas Heat (Low BTU [min]/High BTU [max])					Future offering
AIR MOVEMENT SECTIONS*	MIN AWL (in.)†	MIN Weight (lb)†	MAX AWL (in.)**	MAX Weight (lb)**	
Airfoil Fan	77	1875	79	1913	
Downblast Airfoil Fan	84	1869	87	2016	
Forward Curved Fan	59	1892	71	1927	
Belt-Drive Plenum Fan					Future offering
Direct Drive Plenum Fan	61	1454	69	1830	
Fan Array					Future offering
Vertical Forward Curve Fan					Future offering
Vertical Airfoil Fan					Future offering
Horizontal Direct Drive Plenum Fan with EC Motor					Variable depending upon fan size, quantity, and options. See AHUBuilder.
MISCELLANEOUS SECTIONS	MIN AWL (in.)	MIN Weight (lb)	MAX AWL (in.)	MAX Weight (lb)	
ERV Section					Future offering
Humidifier	24	663	48	831	
Access and Plenum	12	663	48	507	
Turning Plenum	33	473	N/A	N/A	
Sound Attenuator	36	1051	60	1619	

* Refer to AHUBuilder® program for application specific weight and AWL.

† Minimum is based on smallest motor and smallest fan wheel combination.

** Maximum is based on largest motor and largest fan wheel combination.

Dimensions (cont)



Size 36W (18,000 cfm)

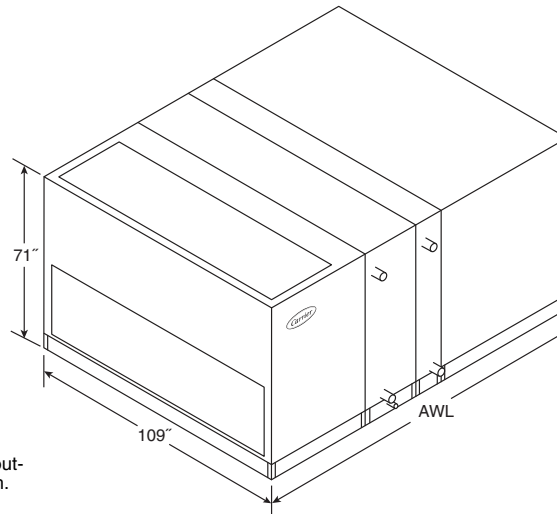

NOTES:

1. Dimensions are shown for indoor units. For outdoor units add 4 in. to height and 3 in. to width.
2. Height dimensions include 6-in. base rail.

LEGEND

- AWL** — Airway Length
- ERV** — Energy Recovery Ventilator
- N/A** — Not Applicable

AIR DISTRIBUTION COMPONENTS		AWL (in.)	Weight (lb)	DAMPER QUANTITY		
	Mixing Box	36	503	3		
	Side Inlet Mixing Box	57	717	2		
	Filter Mixing Box (2-in. or 4-in. Flat Filter)	43	878	3		
	Filter Mixing Box (6-in. Flat Filter)	45	903	3		
	Filter Mixing Box (Angle Filter)	45	903	3		
	Filter Mixing Box (Angle Filter) with Smoke Damper	58	1179	1		
	Filter Mixing Box (Bag Cartridge Filter)	65	1153	3		
	Air Mixer	36	666	N/A		
	Exhaust Box	36	570	3		
	Side Outlet Exhaust Box	57	728	2		
	Combination Exhaust Mixing Box	39	554	2		
	Internal Face and Bypass Damper	18	357	3		
	External Face and Bypass Damper Section	33	1022	3		
	Multizone Damper (Front Discharge) (Two Deck)	5	302	N/A		
	Multizone Damper (Top Discharge) (Two Deck)	5 (height)	303	N/A		
FILTRATION COMPONENTS		AWL (in.)	Weight (lb)	FILTER QUANTITY	FILTER SIZE (in.)	FILTER AREA (ft ²)
	2-in. or 4-in. Flat Filter	12	620	12	20 x 25	41.7
	2-in. Pre-Filter with 4-in. Flat Filter	14	635	12	20 x 25	41.7
	2-in. or 4-in. Angle Filter	26	725	16	20 x 25	55.5
	Short Bag/Side Loading Cartridge Filter	24	729	4 / 8	12 x 24 / 24 x 24	40.0
	Long Bag/Side Loading Cartridge Filter	42	864	4 / 8	12 x 24 / 24 x 24	40.0
	Bag/Front Loading Cartridge Filter	48	912	4 / 8	12 x 24 / 24 x 24	40.0
	Blow-thru Front Loading HEPA Filter	48	913	4 / 8	12 x 24 / 24 x 24	40.0
HEAT TRANSFER SECTIONS		MIN AWL (in.)	MIN Weight (lb)	MAX AWL (in.)	MAX Weight (lb)	Zones
	Coil and Variable Length Plenum (with Drain Pan)	24	402	61	753	
	Coil and Variable Length Plenum (without Drain Pan)	12	312	60	703	
	Dual Coil and Variable Length Plenum (with Drain Pan)	30	402	61	753	
	Vertical Coil	60	769	N/A	N/A	
	Multizone Front Discharge	85	1756	N/A	N/A	17 zones
	Multizone Top Discharge	85	1604	N/A	N/A	17 zones
	Internal Face and Bypass Cooling Coil	24	402	N/A	N/A	
	Internal Face and Bypass Heating Coil	12	312	24	401	
	Integral Face and Bypass Heating Coil	48	590	N/A	N/A	
	Electric Heat with Control Box (Low Amp [min]/High Amp [max])	30	762	30	762	
	Gas Heat (Low BTU [min]/High BTU [max])	100	2092	189	3133	
AIR MOVEMENT SECTIONS*		MIN AWL (in.)†	MIN Weight (lb)†	MAX AWL (in.)**	MAX Weight (lb)**	
	Airfoil Fan	57	1990	57	2017	
	Downblast Airfoil Fan	57	1988	61	2141	
	Forward Curved Fan	60	2044	60	2145	
	Belt-Drive Plenum Fan	54	2121	66	2343	
	Direct Drive Plenum Fan	61	1627	72	2161	
	Fan Array	47	1436	57	2005	
	Vertical Forward Curve Fan	60	2181	60	2253	
	Vertical Airfoil Fan	60	2179	60	2188	
	Horizontal Direct Drive Plenum Fan with EC Motor	Variable depending upon fan size, quantity, and options. See AHUBuilder.				
	Vertical Direct Drive Plenum Fan with EC Motor	Variable depending upon fan size, quantity, and options. See AHUBuilder.				
MISCELLANEOUS SECTIONS		MIN AWL (in.)	MIN Weight (lb)	MAX AWL (in.)	MAX Weight (lb)	
	ERV	147	8716	181	10,368	
	Humidifier	24	714	48	894	
	Access to Plenum	12	330	48	600	
	Turning Plenum	33	563	N/A	N/A	
	Sound Attenuator	36	1168	60	1784	

* Refer to AHUBuilder® program for application specific weight and AWL.

† Minimum is based on smallest motor and smallest fan wheel combination.

** Maximum is based on largest motor and largest fan wheel combination.

Size 37T (18,500 cfm)

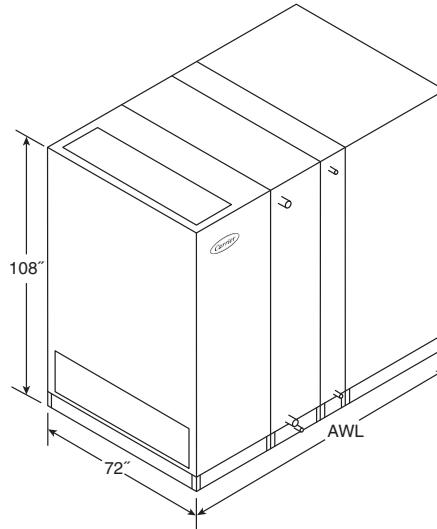

NOTES:

1. Dimensions are shown for indoor units. For outdoor units add 4 in. to height and 3 in. to width.
2. Height dimensions include 6-in. base rail.

LEGEND

- AWL** — Airway Length
- ERV** — Energy Recovery Ventilator
- N/A** — Not Applicable

AIR DISTRIBUTION COMPONENTS	AWL (in.)	Weight (lb)	DAMPER QUANTITY
Mixing Box	45	461	2
Side Inlet Mixing Box	39	613	3
Filter Mixing Box (2-in. or 4-in. Flat Filter)	52	932	2
Filter Mixing Box (6-in. Flat Filter)	54	954	2
Filter Mixing Box (Angle Filter)	50	910	2
Filter Mixing Box (Angle Filter) with Smoke Damper	68	1277	1
Filter Mixing Box (Bag Cartridge Filter)	65	1073	2
Air Mixer	36	648	N/A
Exhaust Box	45	523	2
Side Outlet Exhaust Box	39	623	3
Combination Exhaust Mixing Box	39	508	3
Internal Face and Bypass Damper	18	302	2
External Face and Bypass Damper Section			Future offering
Multizone Damper (Front Discharge) (Two Deck)			Future offering
Multizone Damper (Top Discharge) (Two Deck)			Future offering

FILTRATION COMPONENTS	AWL (in.)	Weight (lb)	FILTER QUANTITY	FILTER SIZE (in.)	FILTER AREA (ft ²)
2-in. or 4-in. Flat Filter	12	577	9 / 3	24 x 20 / 20 x 20	38.3
2-in. Pre-Filter with 4-in. Flat Filter	14	591	9 / 3	24 x 20 / 20 x 20	38.3
2-in. or 4-in. Angle Filter	27	663	24	20 x 16	53.3
Short Bag/Side Loading Cartridge Filter	24	671	6 / 5	24 x 24 / 12 x 24	34.0
Long Bag/Side Loading Cartridge Filter	42	791	6 / 5	24 x 24 / 12 x 24	34.0
Bag/Front Loading Cartridge Filter	48	831	8 / 4	24 x 24 / 12 x 24	40.0
Blow-thru Front Loading HEPA Filter	48	831	6 / 5	24 x 24 / 12 x 24	34.0

HEAT TRANSFER SECTIONS	MIN AWL (in.)	MIN Weight (lb)	MAX AWL (in.)	MAX Weight (lb)
Coil and Variable Length Plenum (with Drain Pan)	24	344	61	647
Coil and Variable Length Plenum (without Drain Pan)	12	262	60	608
Dual Coil and Variable Length Plenum (with Drain Pan)	30	344	61	647
Vertical Coil				Future offering
Multizone Front Discharge				Future offering
Multizone Top Discharge				Future offering
Internal Face and Bypass Cooling Coil	24	344	N/A	N/A
Internal Face and Bypass Heating Coil	12	262	24	342
Integral Face and Bypass Heating Coil	48	635	N/A	N/A
Electric Heat with Control Box (Low Amp [min]/High Amp [max])	30	692	42	711
Gas Heat (Low BTU [min]/High BTU [max])				Future offering

AIR MOVEMENT SECTIONS*	MIN AWL (in.)†	MIN Weight (lb)†	MAX AWL (in.)**	MAX Weight (lb)**
Airfoil Fan	77	1954	79	1994
Downblast Airfoil Fan	84	1946	87	2096
Forward Curved Fan	59	1969	71	2008
Belt-Drive Plenum Fan				Future offering
Direct Drive Plenum Fan	62	1525	72	1911
Fan Array				Future offering
Vertical Forward Curve Fan				Future offering
Vertical Airfoil Fan				Future offering
Horizontal Direct Drive Plenum Fan with EC Motor				Variable depending upon fan size, quantity, and options. See AHUBuilder.

MISCELLANEOUS SECTIONS	MIN AWL (in.)	MIN Weight (lb)	MAX AWL (in.)	MAX Weight (lb)
ERV Section				Future offering
Humidifier	24	687	48	861
Access and Plenum	12	687	48	521
Turning Plenum	33	490	N/A	N/A
Sound Attenuator				Future offering

* Refer to AHUBuilder® program for application specific weight and AWL.

† Minimum is based on smallest motor and smallest fan wheel combination.

** Maximum is based on largest motor and largest fan wheel combination.

Size 40W (20,000 cfm)

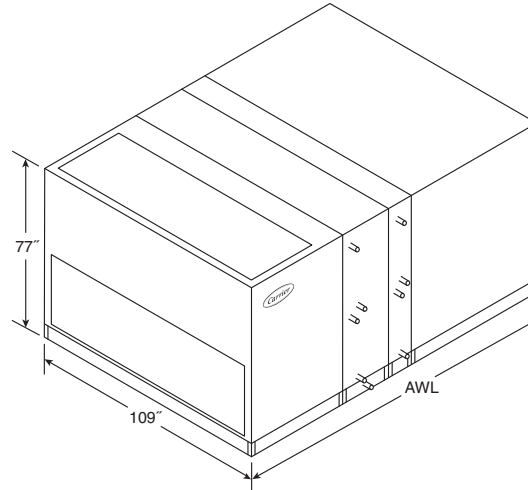

NOTES:

1. Dimensions are shown for indoor units. For outdoor units add 4 in. to height and 3 in. to width.
2. Height dimensions include 6-in. base rail.

LEGEND

- AWL** — Airway Length
- ERV** — Energy Recovery Ventilator
- N/A** — Not Applicable

AIR DISTRIBUTION COMPONENTS		AWL (in.)	Weight (lb)	DAMPER QUANTITY		
Mixing Box	39	538	3			
Side Inlet Mixing Box	57	741	2			
Filter Mixing Box (2-in. or 4-in. Flat Filter)	46	946	3			
Filter Mixing Box (6-in. Flat Filter)	48	971	3			
Filter Mixing Box (Angle Filter)	48	971	3			
Filter Mixing Box (Angle Filter) with Smoke Damper	59	1261	1			
Filter Mixing Box (Bag Cartridge Filter)	65	1190	3			
Air Mixer	42	741	N/A			
Exhaust Box	39	612	3			
Side Outlet Exhaust Box	57	752	2			
Combination Exhaust Mixing Box	39	592	2			
Internal Face and Bypass Damper	18	365	3			
External Face and Bypass Damper Section	33	1097	3			
Multizone Damper (Front Discharge) (Two Deck)	5	331	N/A			
Multizone Damper (Top Discharge) (Two Deck)	5 (height)	330	N/A			
FILTRATION COMPONENTS		AWL (in.)	Weight (lb)	FILTER QUANTITY	FILTER SIZE (in.)	FILTER AREA (ft ²)
2-in. or 4-in. Flat Filter	12	657	13	20 x 25	45.1	
2-in. Pre-Filter with 4-in. Flat Filter	14	673	13	20 x 25	45.1	
2-in. or 4-in. Angle Filter	24	749	24	16 x 25	66.7	
Short Bag/Side Loading Cartridge Filter	24	770	4 / 8	12 x 24 / 24 x 24	40.0	
Long Bag/Side Loading Cartridge Filter	42	909	4 / 8	12 x 24 / 24 x 24	40.0	
Bag/Front Loading Cartridge Filter	48	958	4 / 8	12 x 24 / 24 x 24	40.0	
Blow-thru Front Loading HEPA Filter	48	959	4 / 8	12 x 24 / 24 x 24	40.0	
HEAT TRANSFER SECTIONS		MIN AWL (in.)	MIN Weight (lb)	MAX AWL (in.)	MAX Weight (lb)	Zones
Coil and Variable Length Plenum (with Drain Pan)	24	411	61	773		
Coil and Variable Length Plenum (without Drain Pan)	12	319	60	722		
Dual Coil and Variable Length Plenum (with Drain Pan)	30	411	61	773		
Vertical Coil	60	799	66	835		
Multizone Front Discharge	91	1923	N/A	N/A	17 zones	
Multizone Top Discharge	91	1751	N/A	N/A	17 zones	
Internal Face and Bypass Cooling Coil	24	411	N/A	N/A		
Internal Face and Bypass Heating Coil	12	319	24	411		
Integral Face and Bypass Heating Coil	48	605	N/A	N/A		
Electric Heat with Control Box (Low Amp [min]/High Amp [max])	30	803	30	803		
Gas Heat (Low BTU [min]/High BTU [max])	99	2147	166	4363		
AIR MOVEMENT SECTIONS*		MIN AWL (in.)†	MIN Weight (lb)†	MAX AWL (in.)**	MAX Weight (lb)**	
Airfoil Fan	63	2181	63	2207		
Downblast Airfoil Fan	63	2191	63	2408		
Forward Curved Fan	60	2154	60	2258		
Belt-Drive Plenum Fan	72	2428	72	2519		
Direct Drive Plenum Fan	62	1723	72	2208		
Fan Array	47	1474	57	2046		
Vertical Forward Curve Fan	50	2083	60	2376		
Vertical Airfoil Fan	66	2350	60	2362		
Horizontal Direct Drive Plenum Fan with EC Motor	Variable depending upon fan size, quantity, and options. See AHUBuilder.					
Vertical Direct Drive Plenum Fan with EC Motor	Variable depending upon fan size, quantity, and options. See AHUBuilder.					
MISCELLANEOUS SECTIONS		MIN AWL (in.)	MIN Weight (lb)	MAX AWL (in.)	MAX Weight (lb)	
ERV	176	7609	186	10,825		
Humidifier	24	749	48	934		
Access and Plenum	12	338	48	616		
Turning Plenum	33	587	N/A	N/A		
Sound Attenuator	36	1226	60	1878		

* Refer to AHUBuilder® program for application specific weight and AWL.

† Minimum is based on smallest motor and smallest fan wheel combination.

** Maximum is based on largest motor and largest fan wheel combination.

Size 42T (21,000 cfm)

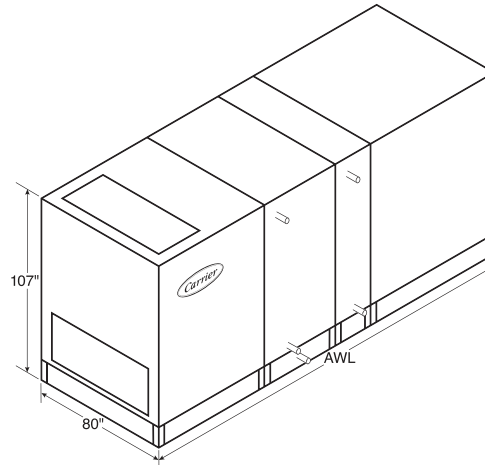

NOTES:

1. Dimensions are shown for indoor units. For outdoor units add 4 in. to height and 3 in. to width.
2. Height dimensions include 6-in. base rail.

LEGEND

- AWL** — Airway Length
- ERV** — Energy Recovery Ventilator
- N/A** — Not Applicable

AIR DISTRIBUTION COMPONENTS		AWL (in.)	Weight (lb)	DAMPER QUANTITY		
Mixing Box	51	506	2			
Side Inlet Mixing Box	45	672	3			
Filter Mixing Box (2-in. or 4-in. Flat Filter)	58	1003	2			
Filter Mixing Box (6-in. Flat Filter)	60	1027	2			
Filter Mixing Box (Angle Filter)	58	1003	2			
Filter Mixing Box (Angle Filter) with Smoke Damper	74	1403	1			
Filter Mixing Box (Bag Cartridge Filter)	71	1154	2			
Air Mixer	42	716	N/A			
Exhaust Box	51	575	2			
Combination Exhaust Mixing Box	45	557	3			
Side Outlet Exhaust Box	45	681	3			
Internal Face and Bypass Damper	18	321	2			
External Face and Bypass Damper Section			Future offering			
Multizone Damper (Front Discharge) (Two Deck)			Future offering			
Multizone Damper (Top Discharge) (Two Deck)			Future offering			
FILTRATION COMPONENTS		AWL (in.)	Weight (lb)	FILTER QUANTITY	FILTER SIZE (in.)	FILTER AREA (ft ²)
2-in. or 4-in. Flat Filter	12	628	9 / 6	16 x 25 / 20 x 25	45.8	
2-in. Pre-Filter with 4-in. Flat Filter	14	642	9 / 6	16 x 25 / 20 x 25	45.8	
2-in. or 4-in. Angle Filter	26	720	18	20 x 25	62.5	
Short Bag/Side Loading Cartridge Filter	24	727	9 / 3	24 x 24 / 12 x 24	42.0	
Long Bag/Side Loading Cartridge Filter	42	855	9 / 3	24 x 24 / 12 x 24	42.0	
Bag/Front Loading Cartridge Filter	48	897	12	24 x 24	48.0	
Blow-thru Front Loading HEPA Filter	48	898	9 / 3	24 x 24 / 12 x 24	42.0	
HEAT TRANSFER SECTIONS		MIN AWL (in.)	MIN Weight (lb)	MAX AWL (in.)	MAX Weight (lb)	
Coil and Variable Length Plenum (with Drain Pan)	24	365	61	688		
Coil and Variable Length Plenum (without Drain Pan)	12	278	60	646		
Dual Coil and Variable Length Plenum (with Drain Pan)	30	365	61	688		
Vertical Coil			Future offering			
Multizone Front Discharge			Future offering			
Multizone Top Discharge			Future offering			
Internal Face and Bypass Cooling Coil	24	365	N/A	N/A		
Internal Face and Bypass Heating Coil	12	278	24	363		
Integral Face and Bypass Heating Coil	48	555	N/A	N/A		
Electric Heat with Control Box (Low Amp [min]/High Amp [max])	30	754	42	771		
Gas Heat (Low BTU [min]/High BTU [max])			Future offering			
AIR MOVEMENT SECTIONS*		MIN AWL (in.)†	MIN Weight (lb)†	MAX AWL (in.)**	MAX Weight (lb)**	
Airfoil Fan	88	2463	95	2245		
Downblast Airfoil Fan	88	2460	95	2297		
Forward Curved Fan	88	2262	95	2209		
Belt-Drive Plenum Fan			Future offering			
Direct Drive Plenum Fan	59	1810	73	2111		
Fan Array			Future offering			
Vertical Forward Curve Fan			Future offering			
Vertical Airfoil Fan			Future offering			
Horizontal Direct Drive Plenum Fan with EC Motor			Variable depending upon fan size, quantity, and options. See AHUBuilder.			
MISCELLANEOUS SECTIONS		MIN AWL (in.)	MIN Weight (lb)	MAX AWL (in.)	MAX Weight (lb)	
ERV Section			Future offering			
Humidifier	24	749	48	936		
Access and Plenum	12	291	48	555		
Turning Plenum			Future offering			
Sound Attenuator			Future offering			

* Refer to AHUBuilder® program for application specific weight and AWL.

† Minimum is based on smallest motor and smallest fan wheel combination.

** Maximum is based on largest motor and largest fan wheel combination.

Size 50W (25,000 cfm)

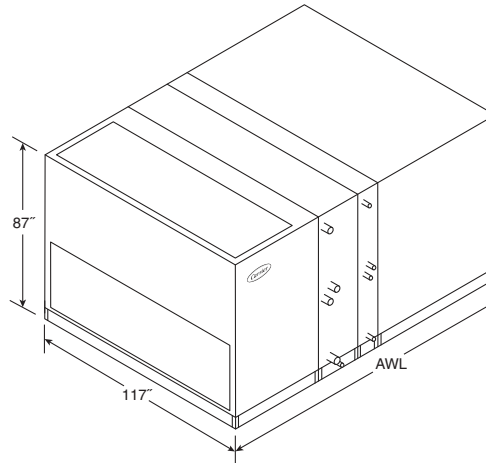

NOTES:

1. Dimensions are shown for indoor units. For outdoor units add 4 in. to height and 3 in. to width.
2. Height dimensions include 6-in. base rail.

LEGEND

- AWL** — Airway Length
- ERV** — Energy Recovery Ventilator
- N/A** — Not Applicable

AIR DISTRIBUTION COMPONENTS	AWL (in.)	Weight (lb)	DAMPER QUANTITY		
Mixing Box	42	616	3		
Side Inlet Mixing Box	63	913	2		
Filter Mixing Box (2-in. or 4-in. Flat Filter)	49	1105	3		
Filter Mixing Box (6-in. Flat Filter)	51	1132	3		
Filter Mixing Box (Angle Filter)	51	1132	3		
Filter Mixing Box (Angle Filter) with Smoke Damper	62	1488	1		
Filter Mixing Box (Bag Cartridge Filter)	62	1285	3		
Air Mixer	42	824	N/A		
Exhaust Box	42	700	3		
Side Outlet Exhaust Box	63	912	2		
Combination Exhaust Mixing Box	63	678	2		
Internal Face and Bypass Damper	18	394	3		
External Face and Bypass Damper Section	39	1327	3		
Multizone Damper (Front Discharge) (Two Deck)	5	402	N/A		
Multizone Damper (Top Discharge) (Two Deck)	5 (height)	401	N/A		
FILTRATION COMPONENTS	AWL (in.)	Weight (lb)	FILTER QUANTITY	FILTER SIZE (in.)	FILTER AREA (ft ²)
2-in. or 4-in. Flat Filter	12	757	15	20 x 25	52.1
2-in. Pre-Filter with 4-in. Flat Filter	14	774	15	20 x 25	52.1
2-in. or 4-in. Angle Filter	24	856	18 / 12	16 x 20 / 16 x 25	73.3
Short Bag/Side Loading Cartridge Filter	24	880	12 / 3	24 x 24 / 24 x 12	54.0
Long Bag/Side Loading Cartridge Filter	42	1031	12 / 3	24 x 24 / 24 x 12	54.0
Bag/Front Loading Cartridge Filter	48	1084	12 / 3	24 x 24 / 24 x 12	54.0
Blow-thru Front Loading HEPA Filter	48	1085	12 / 3	24 x 24 / 24 x 12	54.0
HEAT TRANSFER SECTIONS	MIN AWL (in.)	MIN Weight (lb)	MAX AWL (in.)	MAX Weight (lb)	Zones
Coil and Variable Length Plenum (with Drain Pan)	24	451	61	859	
Coil and Variable Length Plenum (without Drain Pan)	12	343	60	797	
Dual Coil and Variable Length Plenum (with Drain Pan)	30	451	61	859	
Vertical Coil	66	946	72	985	
Multizone Front Discharge	103	2316	N/A	N/A	18 zones
Multizone Top Discharge	103	2069	N/A	N/A	18 zones
Internal Face and Bypass Cooling Coil	24	451	N/A	N/A	
Internal Face and Bypass Heating Coil	12	343	24	444	
Integral Face and Bypass Heating Coil	48	655	N/A	N/A	
Electric Heat with Control Box (Low Amp [min]/High Amp [max])	30	916	30	916	
Gas Heat (Low BTU [min]/High BTU [max])	102	2395	192	3482	
AIR MOVEMENT SECTIONS*	MIN AWL (in.)†	MIN Weight (lb)†	MAX AWL (in.)**	MAX Weight (lb)**	
Airfoil Fan	69	2641	69	2531	
Downblast Airfoil Fan	69	2524	63	2864	
Forward Curved Fan	64	2598	64	2638	
Belt-Drive Plenum Fan	72	2717	72	2957	
Direct Drive Plenum Fan	67	2077	72	2359	
Fan Array	50	2748	61	2676	
Vertical Forward Curve Fan	66	2694	66	2819	
Vertical Airfoil Fan	72	2712	60	2747	
Horizontal Direct Drive Plenum Fan with EC Motor	Variable depending upon fan size, quantity, and options. See AHUBuilder.				
Vertical Direct Drive Plenum Fan with EC Motor	Variable depending upon fan size, quantity, and options. See AHUBuilder.				
MISCELLANEOUS SECTIONS	MIN AWL (in.)	MIN Weight (lb)	MAX AWL (in.)	MAX Weight (lb)	
ERV	164	9194	198	12,754	
Humidifier	24	851	48	1060	
Access and Plenum	12	365	48	667	
Turning Plenum	36	686	N/A	N/A	
Sound Attenuator	36	1366	60	2130	

* Refer to **AHUBuilder**® program for application specific weight and AWL.

† Minimum is based on smallest motor and smallest fan wheel combination.

** Maximum is based on largest motor and largest fan wheel combination.

Size 51T (25,500 cfm)

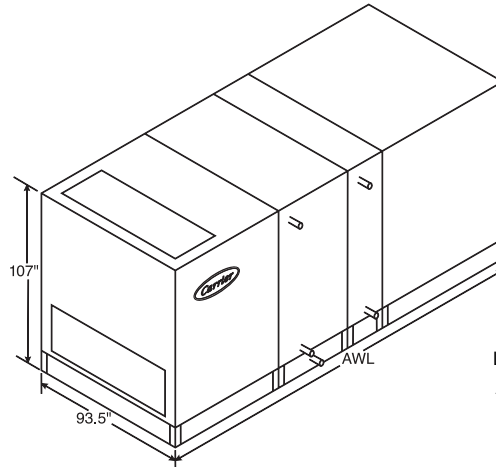

NOTES:

1. Dimensions are shown for indoor units. For outdoor units add 4 in. to height and 3 in. to width.
2. Height dimensions include 6-in. base rail.

LEGEND

- AWL** — Airway Length
- ERV** — Energy Recovery Ventilator
- N/A** — Not Applicable

AIR DISTRIBUTION COMPONENTS		AWL (in.)	Weight (lb)	DAMPER QUANTITY		
	Mixing Box	51	506	2		
	Side Inlet Mixing Box	45	672	3		
	Filter Mixing Box (2-in. or 4-in. Flat Filter)	58	1003	2		
	Filter Mixing Box (6-in. Flat Filter)	60	1027	2		
	Filter Mixing Box (Angle Filter)	58	1003	2		
	Filter Mixing Box (Angle Filter) with Smoke Damper	74	1564	1		
	Filter Mixing Box (Bag Cartridge Filter)	71	1154	2		
	Air Mixer	42	716	N/A		
	Exhaust Box	51	575	2		
	Combination Exhaust Mixing Box	45	557	3		
	Side Outlet Exhaust Box	45	681	3		
	Internal Face and Bypass Damper	18	321	2		
	External Face and Bypass Damper Section				Future offering	
	Multizone Damper (Front Discharge) (Two Deck)				Future offering	
	Multizone Damper (Top Discharge) (Two Deck)				Future offering	
FILTRATION COMPONENTS		AWL (in.)	Weight (lb)	FILTER QUANTITY	FILTER SIZE (in.)	FILTER AREA (ft ²)
	2-in. or 4-in. Flat Filter	12	628	9 / 6	16 x 20 / 20 x 25	50.6
	2-in. Pre-Filter with 4-in. Flat Filter	14	642	9 / 6	16 x 20 / 20 x 25	50.6
	2-in. or 4-in. Angle Filter	26	720	18	16 x 20	66.7
	Short Bag/Side Loading Cartridge Filter	24	727	9 / 3	24 x 24 / 12 x 24	48.0
	Long Bag/Side Loading Cartridge Filter	42	855	9 / 3	24 x 24 / 12 x 24	48.0
	Bag/Front Loading Cartridge Filter	48	897	12	24 x 24 / 12 x 24	56.0
	Blow-thru Front Loading HEPA Filter	48	898	9 / 3	24 x 24 / 12 x 24	50.0
HEAT TRANSFER SECTIONS		MIN AWL (in.)	MIN Weight (lb)	MAX AWL (in.)	MAX Weight (lb)	
	Coil and Variable Length Plenum (with Drain Pan)	24	403	61	763	
	Coil and Variable Length Plenum (without Drain Pan)	12	307	60	713	
	Dual Coil and Variable Length Plenum (with Drain Pan)	30	403	61	763	
	Vertical Coil					Future offering
	Multizone Front Discharge					Future offering
	Multizone Top Discharge					Future offering
	Internal Face and Bypass Cooling Coil	24	403	N/A	N/A	
	Internal Face and Bypass Heating Coil	12	307	24	401	
	Integral Face and Bypass Heating Coil	48	616	N/A	N/A	
	Electric Heat with Control Box (Low Amp [min]/High Amp [max])	30	866	42	878	
	Gas Heat (Low BTU [min]/High BTU [max])					Future offering
AIR MOVEMENT SECTIONS*		MIN AWL (in.)†	MIN Weight (lb)†	MAX AWL (in.)**	MAX Weight (lb)**	
	Airfoil Fan	96	2781	103	2602	
	Downblast Airfoil Fan	96	2771	130	2659	
	Forward Curved Fan	96	2554	103	2570	
	Belt-Drive Plenum Fan					Future offering
	Direct Drive Plenum Fan	63	2120	73	2473	
	Fan Array					Future offering
	Vertical Forward Curve Fan					Future offering
	Vertical Airfoil Fan					Future offering
	Horizontal Direct Drive Plenum Fan with EC Motor					Variable depending upon fan size, quantity, and options. See AHUBuilder.
MISCELLANEOUS SECTIONS		MIN AWL (in.)	MIN Weight (lb)	MAX AWL (in.)	MAX Weight (lb)	
	ERV Section					Future offering
	Humidifier	24	861	48	1071	
	Access and Plenum	12	322	48	616	
	Turning Plenum					Future offering
	Sound Attenuator					Future offering

* Refer to AHUBuilder® program for application specific weight and AWL.

† Minimum is based on smallest motor and smallest fan wheel combination.

** Maximum is based on largest motor and largest fan wheel combination.

Size 58T (29,000 cfm)

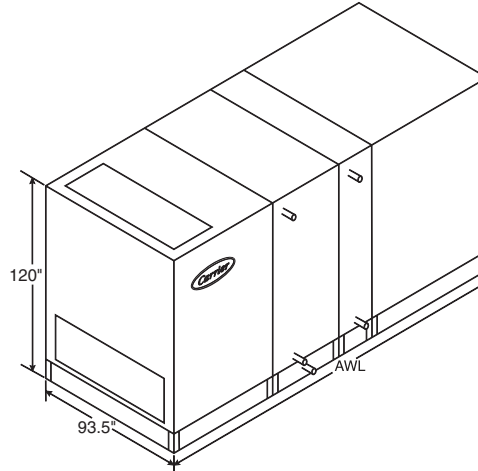

NOTES:

- Dimensions are shown for indoor units. For outdoor units add 4 in. to height and 3 in. to width.
- Height dimensions include 6-in. base rail.

LEGEND

- AWL** — Airway Length
- ERV** — Energy Recovery Ventilator
- N/A** — Not Applicable

AIR DISTRIBUTION COMPONENTS	AWL (in.)	Weight (lb)	DAMPER QUANTITY		
Mixing Box	51	650	2		
Side Inlet Mixing Box	45	859	3		
Filter Mixing Box (2-in. or 4-in. Flat Filter)	58	1310	2		
Filter Mixing Box (6-in. Flat Filter)	60	1338	2		
Filter Mixing Box (Angle Filter)	58	1310	2		
Filter Mixing Box (Angle Filter) with Smoke Damper	70	1671	1		
Filter Mixing Box (Bag Cartridge Filter)	71	1490	2		
Air Mixer	42	933	N/A		
Exhaust Box	51	739	2		
Side Outlet Exhaust Box	45	715	3		
Combination Exhaust Mixing Box	45	866	3		
Internal Face and Bypass Damper	18	380	4		
External Face and Bypass Damper Section				Future offering	
Multizone Damper (Front Discharge) (Two Deck)				Future offering	
Multizone Damper (Top Discharge) (Two Deck)				Future offering	
FILTRATION COMPONENTS	AWL (in.)	Weight (lb)	FILTER QUANTITY	FILTER SIZE (in.)	FILTER AREA (ft ²)
2-in. or 4-in. Flat Filter	12	790	4 / 16	20 x 24 / 20 x 20	57.8
2-in. Pre-Filter with 4-in. Flat Filter	14	807	4 / 16	20 x 24 / 20 x 20	57.8
2-in. or 4-in. Angle Filter	24	902	32	16 x 20	71.1
Short Bag/Side Loading Cartridge Filter	24	909	4 / 12	12 x 24 / 24 x 24	56.0
Long Bag/Side Loading Cartridge Filter	42	1059	4 / 12	12 x 24 / 24 x 24	56.0
Bag/Front Loading Cartridge Filter	48	1109	7 / 12	12 x 24 / 24 x 24	62.0
Blow-thru Front Loading HEPA Filter	48	1109	4 / 12	12 x 24 / 24 x 24	56.0
HEAT TRANSFER SECTIONS	MIN AWL (in.)	MIN Weight (lb)	MAX AWL (in.)	MAX Weight (lb)	
Coil and Variable Length Plenum (with Drain Pan)	24	433	61	821	
Coil and Variable Length Plenum (without Drain Pan)	12	330	60	766	
Dual Coil and Variable Length Plenum (with Drain Pan)	30	433	61	821	
Vertical Coil				Future offering	
Multizone Front Discharge				Future offering	
Multizone Top Discharge				Future offering	
Internal Face and Bypass Cooling Coil	24	433	N/A	N/A	
Internal Face and Bypass Heating Coil	12	330	24	430	
Integral Face and Bypass Heating Coil	48	664	N/A	N/A	
Electric Heat with Control Box (Low Amp [min]/High Amp [max])	30	953	42	962	
Gas Heat (Low BTU [min]/High BTU [max])				Future offering	
AIR MOVEMENT SECTIONS*	MIN AWL (in.)†	MIN Weight (lb)†	MAX AWL (in.)**	MAX Weight (lb)**	
Airfoil Fan	104	3125	107	2879	
Downblast Airfoil Fan	104	3026	107	2940	
Forward Curved Fan	104	2794	107	2851	
Belt-Drive Plenum Fan			Future offering		
Direct Drive Plenum Fan	63	2140	73	2754	
Fan Array			Future offering		
Vertical Forward Curve Fan			Future offering		
Vertical Airfoil Fan			Future offering		
Horizontal Direct Drive Plenum Fan with EC Motor			Variable depending upon fan size, quantity, and options. See AHUBuilder.		
MISCELLANEOUS SECTIONS	MIN AWL (in.)	MIN Weight (lb)	MAX AWL (in.)	MAX Weight (lb)	
ERV Section			Future offering		
Humidifier	24	947	48	1176	
Access and Plenum	12	346	48	664	
Turning Plenum			Future offering		
Sound Attenuator			Future offering		

* Refer to AHUBuilder® program for application specific weight and AWL.

† Minimum is based on smallest motor and smallest fan wheel combination.

** Maximum is based on largest motor and largest fan wheel combination.

Size 61W (30,500 cfm)

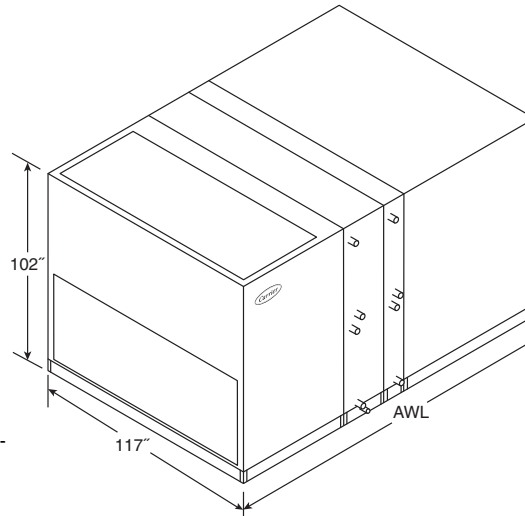

NOTES:

1. Dimensions are shown for indoor units. For outdoor units add 4 in. to height and 3 in. to width.
2. Height dimensions include 6-in. base rail.

LEGEND

- AWL** — Airway Length
- ERV** — Energy Recovery Ventilator
- N/A** — Not Applicable

AIR DISTRIBUTION COMPONENTS	AWL (in.)	Weight (lb)	DAMPER QUANTITY		
Mixing Box	51	723	3		
Side Inlet Mixing Box	63	979	3		
Filter Mixing Box (2-in. or 4-in. Flat Filter)	58	1316	3		
Filter Mixing Box (6-in. Flat Filter)	60	1345	3		
Filter Mixing Box (Angle Filter)	60	1345	3		
Filter Mixing Box (Angle Filter) with Smoke Damper	71	1749	1		
Filter Mixing Box (Bag Cartridge Filter)	71	1507	3		
Air Mixer	48	951	N/A		
Exhaust Box	51	830	3		
Side Outlet Exhaust Box	63	978	3		
Combination Exhaust Mixing Box	63	796	3		
Internal Face and Bypass Damper	18	414	3		
External Face and Bypass Damper Section	45	1573	3		
Multizone Damper (Front Discharge) (Two Deck)	5	480	N/A		
Multizone Damper (Top Discharge) (Two Deck)	5 (height)	480	N/A		
FILTRATION COMPONENTS	AWL (in.)	Weight (lb)	FILTER QUANTITY	FILTER SIZE (in.)	FILTER AREA (ft ²)
2-in. or 4-in. Flat Filter	12	858	14 / 14	20 x 16 / 25 x 16	70.0
2-in. Pre-Filter with 4-in. Flat Filter	14	875	14 / 14	20 x 16 / 25 x 16	70.0
2-in. or 4-in. Angle Filter	24	961	24 / 16	16 x 20 / 16 x 25	97.8
Short Bag/Side Loading Cartridge Filter	24	989	7 / 12	12 x 24 / 24 x 24	62.2
Long Bag/Side Loading Cartridge Filter	42	1151	7 / 12	12 x 24 / 24 x 24	62.2
Bag/Front Loading Cartridge Filter	48	1207	7 / 12	12 x 24 / 24 x 24	62.2
Blow-thru Front Loading HEPA Filter	48	1207	7 / 12	12 x 24 / 24 x 24	62.2
HEAT TRANSFER SECTIONS	MIN AWL (in.)	MIN Weight (lb)	MAX AWL (in.)	MAX Weight (lb)	Zones
Coil and Variable Length Plenum (with Drain Pan)	24	475	61	908	
Coil and Variable Length Plenum (without Drain Pan)	12	361	60	845	
Dual Coil and Variable Length Plenum (with Drain Pan)	30	475	61	908	
Vertical Coil	66	1030	78	1115	
Multizone Front Discharge	121	2725	N/A	N/A	18 zones
Multizone Top Discharge	121	2411	N/A	N/A	18 zones
Internal Face and Bypass Cooling Coil	24	475	N/A	N/A	
Internal Face and Bypass Heating Coil	12	361	24	468	
Integral Face and Bypass Heating Coil	48	695	N/A	N/A	
Electric Heat with Control Box (Low Amp [min]/High Amp [max])	30	1025	30	1025	
Gas Heat (Low BTU [min]/High BTU [max])	102	2506	169	5002	
AIR MOVEMENT SECTIONS*	MIN AWL (in.)†	MIN Weight (lb)†	MAX AWL (in.)**	MAX Weight (lb)**	
Airfoil Fan	69	2997	75	3238	
Downblast Airfoil Fan	69	2979	75	3226	
Forward Curved Fan	66	2811	66	2961	
Belt-Drive Plenum Fan	78	3112	78	3441	
Direct Drive Plenum Fan	68	2159	72	2481	
Fan Array	50	2869	65	3191	
Vertical Forward Curve Fan	66	3003	66	3153	
Vertical Airfoil Fan	78	3222	78	3452	
Horizontal Direct Drive Plenum Fan with EC Motor	Variable depending upon fan size, quantity, and options. See AHUBuilder.				
Vertical Direct Drive Plenum Fan with EC Motor	Variable depending upon fan size, quantity, and options. See AHUBuilder.				
MISCELLANEOUS SECTIONS	MIN AWL (in.)	MIN Weight (lb)	MAX AWL (in.)	MAX Weight (lb)	
ERV	187	10821	225	15271	
Humidifier	24	943	48	1166	
Access and Plenum	12	385	48	706	
Turning Plenum	36	751	N/A	N/A	
Sound Attenuator	36	1498	60	2355	

* Refer to AHUBuilder® program for application specific weight and AWL.

† Minimum is based on smallest motor and smallest fan wheel combination.

** Maximum is based on largest motor and largest fan wheel combination.

Dimensions (cont)



Size 72W (36,000 cfm)

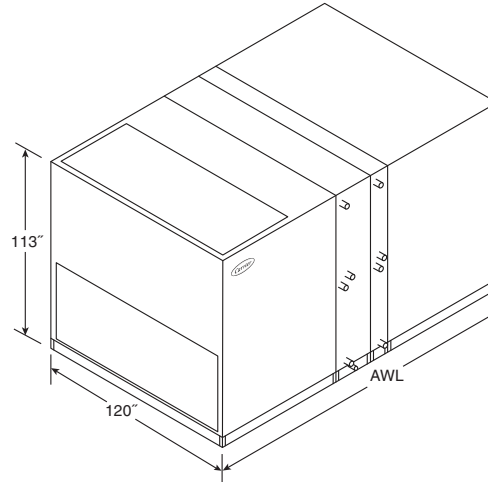

- NOTES:
1. Dimensions are shown for indoor units. For outdoor units add 4 in. to height and 3 in. to width.
 2. Height dimensions include 6-in. base rail.

LEGEND

- AWL — Airway Length
 ERV — Energy Recovery Ventilator
 N/A — Not Applicable

AIR DISTRIBUTION COMPONENTS	AWL (in.)	Weight (lb)	DAMPER QUANTITY		
Mixing Box	53	795	3		
Side Inlet Mixing Box	57	953	3		
Filter Mixing Box (2-in. or 4-in. Flat Filter)	60	1381	3		
Filter Mixing Box (6-in. Flat Filter)	62	1412	3		
Filter Mixing Box (Angle Filter)	79	1675	3		
Filter Mixing Box (Bag Cartridge Filter)	73	1582	3		
Air Mixer	60	1195	N/A		
Exhaust Box	54	914	3		
Side Outlet Exhaust Box	57	954	3		
Combination Exhaust Mixing Box	57	875	3		
Internal Face and Bypass Damper	18	435	3		
External Face and Bypass Damper Section	54	1837	3		

FILTRATION COMPONENTS	AWL (in.)	Weight (lb)	FILTER QUANTITY	FILTER SIZE (in.)	FILTER AREA (ft ²)
2-in. or 4-in. Flat Filter	12	959	33	20 x 16	73.3
2-in. Pre-Filter with 4-in. Flat Filter	14	978	33	20 x 16	73.3
2-in. or 4-in. Angle Filter	27	1098	56	16 x 20	124.4
Short Bag/Side Loading Cartridge Filter	24	1101	16 / 4	24 x 24 / 24 x 12	72.0
Long Bag/Side Loading Cartridge Filter	42	1272	16 / 4	24 x 24 / 24 x 12	72.0
Bag/Front Loading Cartridge Filter	48	1328	16 / 4	24 x 24 / 24 x 12	72.0
Blow-thru Front Loading HEPA Filter	48	1329	16 / 4	24 x 24 / 24 x 12	72.0

HEAT TRANSFER SECTIONS	MIN AWL (in.)	MIN Weight (lb)	MAX AWL (in.)	MAX Weight (lb)
Coil and Variable Length Plenum (with Drain Pan)	24	499	61	966
Coil and Variable Length Plenum (without Drain Pan)	12	378	60	890
Dual Coil and Variable Length Plenum (with Drain Pan)	30	499	61	966
Vertical Coil	N/A	N/A	N/A	N/A
Multizone Front Discharge	N/A	N/A	N/A	N/A
Multizone Top Discharge	N/A	N/A	N/A	N/A
Internal Face and Bypass Cooling Coil	24	499	N/A	N/A
Internal Face and Bypass Heating Coil	12	378	24	492
Integral Face and Bypass Heating Coil	48	732	N/A	N/A
Electric Heat with Control Box (Low Amp [min]/High Amp [max])	30	1133	30	1133
Gas Heat (Low BTU [min]/High BTU [max])	100	2894	167	6132

AIR MOVEMENT SECTIONS*	MIN AWL (in.)†	MIN Weight (lb)†	MAX AWL (in.)**	MAX Weight (lb)**
Airfoil Fan	70	3320	76	3551
Downblast Airfoil Fan	72	3307	79	3565
Forward Curved Fan	70	3320	76	3563
Belt-Drive Plenum Fan	67	3502	70	3725
Direct Drive Plenum Fan	N/A	N/A	N/A	N/A
Fan Array	51	3233	69	3372
Vertical Forward Curve Fan	N/A	N/A	N/A	N/A
Vertical Airfoil Fan	N/A	N/A	N/A	N/A
Horizontal Direct Drive Plenum Fan with EC Motor	Variable depending upon fan size, quantity, and options. See AHUBuilder.			

MISCELLANEOUS SECTIONS	MIN AWL (in.)	MIN Weight (lb)	MAX AWL (in.)	MAX Weight (lb)
Access and Plenum	12	405	48	744
Turning Plenum	34	796	N/A	N/A
Sound Attenuator			Future offering	

* Refer to AHUBuilder® program for application specific weight and AWL.

† Minimum is based on smallest motor and smallest fan wheel combination.

** Maximum is based on largest motor and largest fan wheel combination.

Size 85W (42,500 cfm)

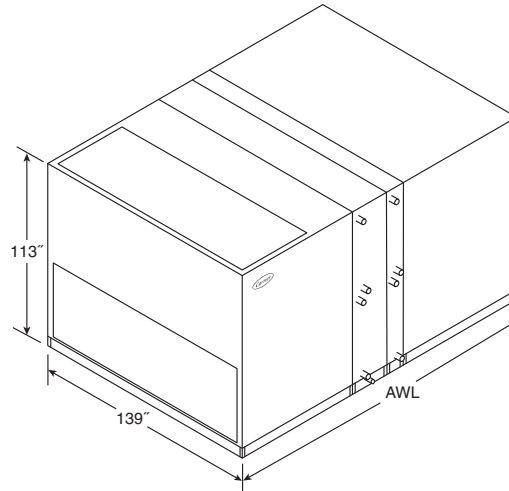

NOTES:

1. Dimensions are shown for indoor units. For outdoor units add 4 in. to height and 3 in. to width.
2. Height dimensions include 6-in. base rail.

LEGEND

- AWL** — Airway Length
- ERV** — Energy Recovery Ventilator
- N/A** — Not Applicable

AIR DISTRIBUTION COMPONENTS		AWL (in.)	Weight (lb)	DAMPER QUANTITY		
	Mixing Box	53	874	3		
	Side Inlet Mixing Box	65	1166	3		
	Filter Mixing Box (2-in. or 4-in. Flat Filter)	60	1539	3		
	Filter Mixing Box (6-in. Flat Filter)	62	1573	3		
	Filter Mixing Box (Angle Filter)	79	1861	3		
	Filter Mixing Box (Bag Cartridge Filter)	73	1760	3		
	Air Mixer	66	1371	N/A		
	Exhaust Box	53	1003	3		
	Side Outlet Exhaust Box	65	1169	3		
	Combination Exhaust Mixing Box	65	962	3		
	Internal Face and Bypass Damper	18	475	3		
	External Face and Bypass Damper Section	53	2092	3		
FILTRATION COMPONENTS		AWL (in.)	Weight (lb)	FILTER QUANTITY	FILTER SIZE (in.)	FILTER AREA (ft ²)
	2-in. or 4-in. Flat Filter	12	1091	38	20 x 16	84.4
	2-in. Pre-Filter with 4-in. Flat Filter	14	1112	38	20 x 16	84.4
	2-in. or 4-in. Angle Filter	27	1246	64	16 x 20	142.2
	Short Bag/Side Loading Cartridge Filter	24	1245	20 / 4	24 x 24 / 24 x 12	88.0
	Long Bag/Side Loading Cartridge Filter	42	1434	20 / 4	24 x 24 / 24 x 12	88.0
	Bag/Front Loading Cartridge Filter	48	1496	20 / 4	24 x 24 / 24 x 12	88.0
	Blow-thru Front Loading HEPA Filter	48	1496	20	24 x 24	88.0
HEAT TRANSFER SECTIONS		MIN AWL (in.)	MIN Weight (lb)	MAX AWL (in.)	MAX Weight (lb)	
	Coil and Variable Length Plenum (with Drain Pan)	24	542	61	1031	
	Coil and Variable Length Plenum (without Drain Pan)	12	412	60	955	
	Dual Coil and Variable Length Plenum (with Drain Pan)	30	542	61	1031	
	Internal Face and Bypass Cooling Coil	24	542	N/A	N/A	
	Internal Face and Bypass Heating Coil	12	412	24	537	
	Integral Face and Bypass Heating Coil	48	801	N/A	N/A	
	Electric Heat with Control Box (Low Amp [min]/High Amp [max])	30	1281	30	1281	
	Gas Heat (Low BTU [min]/High BTU [max])	100	3166	167	6590	
AIR MOVEMENT SECTIONS*		MIN AWL (in.)†	MIN Weight (lb)†	MAX AWL (in.)**	MAX Weight (lb)**	
	Airfoil Fan	76	3844	81	3999	
	Downblast Airfoil Fan	79	3753	86	4022	
	Forward Curved Fan	76	3844	81	3999	
	Belt-Drive Plenum Fan	76	4015	79	4219	
	Fan Array	54	3985	72	3777	
	Horizontal Direct Drive Plenum Fan with EC Motor	Variable depending upon fan size, quantity, and options. See AHUBuilder.				
MISCELLANEOUS SECTIONS		MIN AWL (in.)	MIN Weight (lb)	MAX AWL (in.)	MAX Weight (lb)	
	Access and Plenum	12	441	48	815	
	Turning Plenum	34	876	N/A	N/A	
	Sound Attenuator			Future offering		

* Refer to AHUBuilder® program for application specific weight and AWL.

† Minimum is based on smallest motor and smallest fan wheel combination.

** Maximum is based on largest motor and largest fan wheel combination.

Size 96W (48,000 cfm)

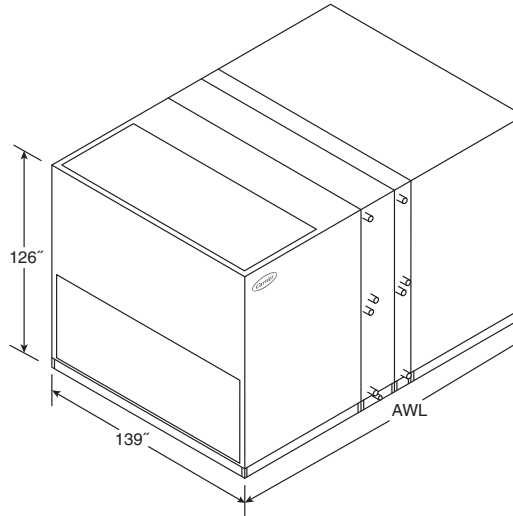

NOTES:

1. Dimensions are shown for indoor units. For outdoor units add 4 in. to height and 3 in. to width.
2. Height dimensions include 6-in. base rail.

LEGEND

- AWL** — Airway Length
- ERV** — Energy Recovery Ventilator
- N/A** — Not Applicable

AIR DISTRIBUTION COMPONENTS		AWL (in.)	Weight (lb)	DAMPER QUANTITY		
Mixing Box		59	1025	3		
Side Inlet Mixing Box		65	1229	3		
Filter Mixing Box (2-in. or 4-in. Flat Filter)		66	1732	3		
Filter Mixing Box (6-in. Flat Filter)		68	1767	3		
Filter Mixing Box (Angle Filter)		84	2050	3		
Filter Mixing Box (Bag Cartridge Filter)		79	1962	3		
Air Mixer		69	1487	N/A		
Exhaust Box		59	1160	3		
Side Outlet Exhaust Box		65	1231	3		
Combination Exhaust Mixing Box		65	113	3		
Internal Face and Bypass Damper		18	493	3		
External Face and Bypass Damper Section		59	2389	3		
FILTRATION COMPONENTS		AWL (in.)	Weight (lb)	FILTER QUANTITY	FILTER SIZE (in.)	FILTER AREA (ft ²)
2-in. or 4-in. Flat Filter		12	1189	24 / 12	20 x 16 x 20 x 25	95.0
2-in. Pre-Filter with 4-in. Flat Filter		14	1211	24 / 12	20 x 16 x 20 x 25	95.0
2-in. or 4-in. Angle Filter		27	1349	64	16 x 20	142.2
Short Bag/Side Loading Cartridge Filter		24	1351	20 / 9	24 x 24 / 24 x 12	98.0
Long Bag/Side Loading Cartridge Filter		42	1549	20 / 9	24 x 24 / 24 x 12	98.0
Bag/Front Loading Cartridge Filter		48	1614	20 / 9	24 x 24 / 24 x 12	98.0
Blow-thru Front Loading HEPA Filter		48	1614	20 / 5	24 x 24 / 24 x 12	98.0
HEAT TRANSFER SECTIONS		MIN AWL (in.)	MIN Weight (lb)	MAX AWL (in.)	MAX Weight (lb)	
Coil and Variable Length Plenum (with Drain Pan)		24	562	61	1073	
Coil and Variable Length Plenum (without Drain Pan)		12	427	60	997	
Dual Coil and Variable Length Plenum (with Drain Pan)		30	562	61	1073	
Internal Face and Bypass Cooling Coil		24	562	N/A	N/A	
Internal Face and Bypass Heating Coil		12	427	24	558	
Integral Face and Bypass Heating Coil		48	835	N/A	N/A	
Electric Heat with Control Box (Low Amp [min]/High Amp [max])		30	1386	30	1386	
Gas Heat (Low BTU [min]/High BTU [max])		104	3562	195	5667	
AIR MOVEMENT SECTIONS*		MIN AWL (in.)†	MIN Weight (lb)†	MAX AWL (in.)**	MAX Weight (lb)**	
Airfoil Fan		76	4241	81	4308	
Downblast Airfoil Fan		79	4153	86	4333	
Forward Curved Fan		76	4241	81	4308	
Belt-Drive Plenum Fan		79	4372	89	4675	
Fan Array		54	4198	72	3897	
Horizontal Direct Drive Plenum Fan with EC Motor			Variable depending upon fan size, quantity, and options. See AHUBuilder.			
MISCELLANEOUS SECTIONS		MIN AWL (in.)	MIN Weight (lb)	MAX AWL (in.)	MAX Weight (lb)	
Access and Plenum		12	458	48	849	
Turning Plenum		38	971	N/A	N/A	
Sound Attenuator				Future offering		

* Refer to AHUBuilder® program for application specific weight and AWL.

† Minimum is based on smallest motor and smallest fan wheel combination.

** Maximum is based on largest motor and largest fan wheel combination.

Size 110W (55,000 cfm)

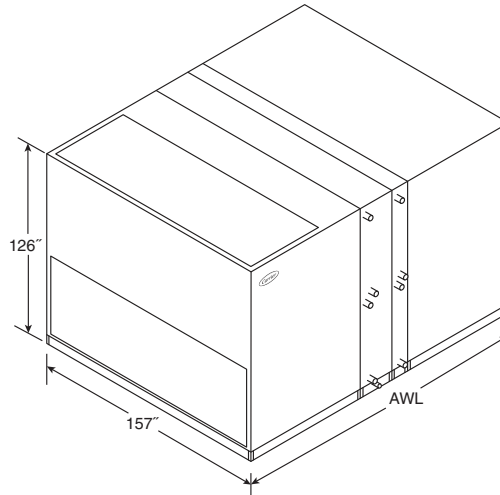

NOTES:

1. Dimensions are shown for indoor units. For outdoor units add 4 in. to height and 3 in. to width.
2. Height dimensions include 6-in. base rail.

LEGEND

- AWL** — Airway Length
- ERV** — Energy Recovery Ventilator
- N/A** — Not Applicable

AIR DISTRIBUTION COMPONENTS		AWL (in.)	Weight (lb)	DAMPER QUANTITY		
	Mixing Box	59	1025	4		
	Side Inlet Mixing Box	73	1410	4		
	Filter Mixing Box (2-in. or 4-in. Flat Filter)	66	1922	4		
	Filter Mixing Box (6-in. Flat Filter)	68	1957	4		
	Filter Mixing Box (Angle Filter)	84	2240	4		
	Filter Mixing Box (Bag Cartridge Filter)	79	2152	4		
	Air Mixer	69	1487	N/A		
	Exhaust Box	59	1160	4		
	Side Outlet Exhaust Box	73	1415	4		
	Combination Exhaust Mixing Box	73	113	4		
	Internal Face and Bypass Damper	18	527	4		
	External Face and Bypass Damper Section	59	2389	4		
FILTRATION COMPONENTS		AWL (in.)	Weight (lb)	FILTER QUANTITY	FILTER SIZE (in.)	FILTER AREA (ft²)
	2-in. or 4-in. Flat Filter	12	1189	27 / 14	20 x 16 / 20 x 25	108.6
	2-in. Pre-Filter with 4-in. Flat Filter	14	1211	27 / 14	20 x 16 / 20 x 25	108.6
	2-in. or 4-in. Angle Filter	27	1349	72	16 x 20	160.0
	Short Bag/Side Loading Cartridge Filter	24	1351	24 / 6	24 x 24 / 24 x 12	108.0
	Long Bag/Side Loading Cartridge Filter	42	1549	24 / 6	24 x 24 / 24 x 12	108.0
	Bag/Front Loading Cartridge Filter	48	1614	24 / 6	24 x 24 / 24 x 12	108.0
	Blow-thru Front Loading HEPA Filter	48	1614	24 / 6	24 x 24 / 24 x 12	108.0
HEAT TRANSFER SECTIONS		MIN AWL (in.)	MIN Weight (lb)	MAX AWL (in.)	MAX Weight (lb)	
	Coil and Variable Length Plenum (with Drain Pan)	24	601	61	1143	
	Coil and Variable Length Plenum (without Drain Pan)	12	458	60	1059	
	Dual Coil and Variable Length Plenum (with Drain Pan)	30	601	61	1143	
	Vertical Coil	N/A	N/A	N/A	N/A	
	Internal Face and Bypass Cooling Coil	24	601	N/A	N/A	
	Internal Face and Bypass Heating Coil	12	458	24	596	
	Integral Face and Bypass Heating Coil	48	889	N/A	N/A	
	Electric Heat with Control Box (Low Amp [min]/High Amp [max])	30	1530	30	1530	
	Gas Heat (Low BTU [min]/High BTU [max])	104	3962	195	7669	
AIR MOVEMENT SECTIONS*		MIN AWL (in.)†	MIN Weight (lb)†	MAX AWL (in.)**	MAX Weight (lb)**	
	Airfoil Fan	72	4693	81	4703	
	Downblast Airfoil Fan	86	4638	92	4794	
	Forward Curved Fan	81	4703	81	4703	
	Belt-Drive Plenum Fan	85	4890	95	5202	
	Fan Array	54	4333	72	4044	
	Horizontal Direct Drive Plenum Fan with EC Motor	Variable depending upon fan size, quantity, and options. See AHUBuilder.				
MISCELLANEOUS SECTIONS		MIN AWL (in.)	MIN Weight (lb)	MAX AWL (in.)	MAX Weight (lb)	
	Access and Plenum	12	458	48	849	
	Turning Plenum	38	971	N/A	N/A	
	Sound Attenuator			Future offering		

* Refer to AHUBuilder® program for application specific weight and AWL.
 † Minimum is based on smallest motor and smallest fan wheel combination.
 ** Maximum is based on largest motor and largest fan wheel combination.

Air Friction Data Typical Filter Pressure Drop (in. wg)

39M COMPONENT	FILTER TYPE	AIR VELOCITY THROUGH FILTER SECTION (FPM)											
		200	250	300	350	400	450	500	550	600	650	700	
FLAT	Throwaway (2 in.)	0.05	0.08	0.11	0.14	0.19	0.22	0.28	0.32	0.35	0.40	0.46	
	Permanent (2 in.)	0.03	0.04	0.05	0.07	0.09	0.11	0.13	0.15	0.17	0.19	0.21	
	Throwaway (4 in.)	0.06	0.09	0.12	0.15	0.19	0.22	0.28	0.32	0.35	0.40	0.46	
FILTER/MIXING BOX*	Throwaway (2 in.)	0.03	0.04	0.05	0.07	0.08	0.10	0.12	0.15	0.17	0.20	0.22	
	Permanent (2 in.)	0.02	0.03	0.04	0.05	0.06	0.08	0.09	0.10	0.12	0.14	0.15	
	Throwaway (4 in.)	0.04	0.05	0.06	0.08	0.08	0.10	0.12	0.15	0.17	0.20	0.22	
ANGLE*	Throwaway (2 in.)	0.01	0.02	0.03	0.05	0.05	0.06	0.07	0.08	0.11	0.12	0.14	
	Permanent (2 in.)	0.01	0.01	0.02	0.03	0.04	0.04	0.06	0.06	0.08	0.09	0.10	
	Throwaway (4 in.)	0.02	0.03	0.04	0.06	0.05	0.06	0.07	0.08	0.11	0.12	0.14	
BAG/ CARTRIDGE	Bag† (% Efficient)	(60-65)	0.07	0.10	0.13	0.17	0.21	0.25	0.30	0.36	0.40	0.48	0.52
		(80-85)	0.14	0.18	0.22	0.27	0.32	0.38	0.43	0.48	0.54	0.60	0.65
		(90-95)	0.23	0.29	0.36	0.43	0.51	0.60	0.67	0.75	0.85	0.94	1.00
	Cartridge** (% Efficient)	(60-65)	0.11	0.15	0.19	0.23	0.27	0.31	0.35	0.39	0.43	0.47	0.51
		(80-85)	0.20	0.25	0.30	0.35	0.40	0.45	0.50	0.55	0.60	0.65	0.71
		(90-95)	0.23	0.30	0.37	0.44	0.51	0.58	0.65	0.72	0.79	0.85	0.92
HEPA††		0.54	0.68	0.82	0.97	1.11	1.25	1.40	1.53	1.67	1.83	1.95	

*Filter data shown is for clean filter. Consult filter manufacturer's recommendation for final dirty-filter pressure drop. Typically, 0.5 in. wg is allowed for dirty filter. Add pressure drop for pre-filter (flat filter) if used.

†Filter data shown is for clean filter. Consult filter manufacturer's recommendation for final dirty-filter pressure drop. Typically, 1.0 in. wg is allowed for dirty filter. Add pressure drop for pre-filter (flat filter) if used.

**Filter data shown is for clean filter. Consult filter manufacturer's recommendation for final dirty-filter pressure drop. Typically, 1.5 in. wg is allowed for dirty filter. Add pressure drop for pre-filter (flat filter) if used.

††Filter data shown is for clean filter. Consult filter manufacturer's recommendation for final dirty-filter pressure drop. Typically, 2.5 in. wg is allowed for dirty filter. Add pressure drop for pre-filter (flat filter) if used.

NOTE: Filters are field-supplied and field-installed. Pressure drop values shown are typical and can vary with manufacturer and filter efficiency.

Component Pressure Drop (in. wg)

39M COMPONENT	STANDARD DAMPERS OR COMPONENT CONSTRUCTION										
	AIR VELOCITY THROUGH COMPONENT (FPM)										
	400	600	800	1000	1200	1400	1600	1800	2000	3000	4000
AIR MIXER	—	0.07	0.11	0.15	0.21	0.29	0.39	—	—	—	—
DIFFUSER PLATE	0.01	0.02	0.04	0.05	0.08	0.10	0.14	0.17	0.22	0.56	—
ELECTRIC HEAT	0.01	0.02	0.04	0.05	0.08	0.10	0.14	—	—	—	—
MIXING OR EXHAUST BOX	0.02	0.05	0.10	0.15	0.22	0.31	0.40	0.50	0.62	1.38	—
ZONE DAMPER	—	—	—	0.03	0.04	0.06	0.07	0.09	0.10	0.25	0.48
SIDE INTAKE LOUVER	0.02	0.05	0.08	0.13	0.18	0.25	0.33	—	—	—	—
REAR INLET HOOD	0.24	0.53	0.94	1.47	—	—	—	—	—	—	—

39M COMPONENT	PREMIUM DAMPERS OR COMPONENT CONSTRUCTION										
	AIR VELOCITY THROUGH DAMPERS (FPM)										
	400	600	800	1000	1200	1400	1600	1800	2000	3000	4000
MIXING OR EXHAUST BOX	0.02	0.04	0.07	0.11	0.16	0.22	0.28	0.36	0.44	1.00	—
SIDE MIXING OR EXHAUST BOX	0.02	0.04	0.07	0.11	0.16	0.22	0.28	0.36	0.44	1.00	—

NOTES:

- For mixing box dampers, worst case pressure drops will occur with one damper open and one closed. With one damper partially open and one partially closed, the actual pressure drop will be much less.
- Diffuser plates are mounted on fan discharge.

Cooling Coil Air Friction (in. wg, Dry Coil)

ROWS	FINS	FACE VELOCITY (fpm)				
		300	400	500	600	700
4	8	0.15	0.25	0.37	0.51	0.66
	11	0.19	0.31	0.45	0.61	0.79
	14	0.23	0.36	0.52	0.70	0.90
6	8	0.23	0.38	0.55	0.76	1.00
	11	0.29	0.46	0.67	0.91	1.18
	14	0.34	0.55	0.79	1.06	1.36
8	8	0.30	0.50	0.74	1.02	1.33
	11	0.38	0.62	0.90	1.22	1.57
	14	0.46	0.73	1.05	1.41	1.81
10	8	0.38	0.63	0.92	1.27	1.66
	11	0.48	0.77	1.12	1.52	1.97
	14	0.57	0.91	1.31	1.76	2.26

Heating Coil Air Friction (in. wg)

ROWS	FINS	FACE VELOCITY (fpm)									
		300	400	500	600	700	800	900	1000	1100	
1 or 2	8	0.08	0.13	0.19	0.26	0.34	0.43	0.53	0.64	0.75	
	11	0.09	0.15	0.22	0.30	0.39	0.50	0.61	0.72	0.85	
	14	0.12	0.19	0.27	0.37	0.47	0.59	0.71	0.85	0.99	
4	8	0.15	0.25	0.37	0.51	0.66	—	—	—	—	
	11	0.19	0.31	0.45	0.61	0.79	—	—	—	—	
	14	0.23	0.36	0.52	0.70	0.90	—	—	—	—	

Steam Coil Air Friction (in. wg)

ROWS	FINS	FACE VELOCITY (fpm)									
		300	400	500	600	700	800	900	1000	1100	1200
1 or 2	6	0.03	0.05	0.07	0.10	0.13	0.16	0.20	0.25	0.29	0.34
	9	0.07	0.11	0.17	0.22	0.30	0.38	0.46	0.55	0.65	0.76
	12	0.12	0.18	0.27	0.37	0.47	0.58	0.72	0.85	1.01	1.15



Electric Heater Data

39M UNIT SIZE	AIRFLOW	FACE AREA	LOW kW EH							HIGH kW EH						
			MIN kW	MAX kW	kW / SQ FT	MAX AMPS	SUB CIRCUITS AT MAX AMPS	CONTROL CIRCUITS AT MAX kW (SEE NOTE 1)	TEMP RISE AT 100% AIRFLOW	MIN kW	MAX kW	kW / SQ FT	MAX AMPS	SUB CIRCUITS AT MAX AMPS	CONTROL CIRCUITS AT MAX kW (SEE NOTE 1)	TEMP RISE AT 100% AIRFLOW
208V, LFA, Open Elements, Standard Controls without Disconnect																
03W	1,500	2.66	5	17	6.4	47	1	3	35.7	18	35	13	97	3	3	73.4
06W	3,000	4.90	10	51	10.4	142	3	3	53.5	52	60	12	167	4	3	62.9
07T	3,500	7.13	10	51	7.2	142	3	3	45.8	52	70	10	195	5	6	62.9
08W	4,000	7.03	20	51	7.3	142	3	3	40.1	52	80	11	222	5	6	62.9
09T	4,500	7.61	20	51	6.7	142	3	3	35.7	52	90	12	250	6	6	62.9
10W	5,000	9.54	20	51	5.3	142	3	3	32.1	52	100	10	278	6	6	62.9
11T	5,500	10.26	20	51	5.0	142	3	3	29.2	52	100	10	278	6	6	57.2
12T	6,000	11.38	20	51	4.5	142	3	3	26.7	52	100	9	278	6	6	52.4
12W	6,000	11.95	20	60	5.0	167	4	3	31.5	61	100	8	278	6	6	52.4
14W	7,000	13.15	30	60	4.6	167	4	3	27.0	61	100	8	278	6	6	44.9
16T	8,000	14.60	30	60	4.1	167	4	3	23.6	61	100	7	278	6	6	39.3
17W	8,500	16.12	30	60	3.7	167	4	3	22.2	61	100	6	278	6	6	37.0
18T	9,000	16.67	30	60	3.6	167	4	3	21.0	61	100	6	278	6	6	35.0
21W	10,500	20.39	40	100	4.9	278	6	6	30.0	—	—	—	—	—	—	—
22T	11,000	21.18	40	100	4.7	278	6	6	28.6	—	—	—	—	—	—	—
25T	12,500	23.45	40	100	4.3	278	6	6	25.2	—	—	—	—	—	—	—
25W	12,500	22.71	40	100	4.4	278	6	6	25.2	—	—	—	—	—	—	—
30T	15,000	29.05	40	100	3.4	278	6	6	21.0	—	—	—	—	—	—	—
30W	15,000	28.68	40	100	3.5	278	6	6	21.0	—	—	—	—	—	—	—
35T	17,500	34.61	60	100	2.9	278	6	6	18.0	—	—	—	—	—	—	—
36W	18,000	37.33	60	100	2.7	278	6	6	17.5	—	—	—	—	—	—	—
37T	18,500	36.24	60	100	2.8	278	6	6	17.0	—	—	—	—	—	—	—
40W	20,000	41.14	60	100	2.4	278	6	6	15.7	—	—	—	—	—	—	—
42T	21,000	41.12	60	100	2.4	278	6	6	15.0	—	—	—	—	—	—	—
50W	25,000	51.65	60	100	1.9	278	6	6	12.6	—	—	—	—	—	—	—
51T	25,500	50.01	60	100	2.0	278	6	6	12.3	—	—	—	—	—	—	—
58T	29,000	56.87	60	100	1.8	278	6	6	10.8	—	—	—	—	—	—	—
61W	30,500	62.01	60	100	1.6	278	6	6	10.3	—	—	—	—	—	—	—
72W	36,000	71.71	60	120	1.7	333	7	6	10.5	—	—	—	—	—	—	—
85W	42,500	85.01	60	120	1.4	333	7	6	8.9	—	—	—	—	—	—	—
96W	48,000	95.98	60	155	1.6	431	9	6	10.2	—	—	—	—	—	—	—
110W	55,000	110.20	60	155	1.4	431	9	6	8.9	—	—	—	—	—	—	—
208V, LFA, Sheathed Elements, Standard Controls without Disconnect																
03W	1,500	2.32	5	17	7.3	47	1	3	35.7	18	35	15	97	3	3	73.4
06W	3,000	4.55	10	51	11.2	142	3	3	53.5	52	60	13	167	4	3	62.9
07T	3,500	6.47	10	51	7.9	142	3	3	45.8	52	70	11	195	5	6	62.9
08W	4,000	6.65	20	51	7.7	142	3	3	40.1	52	80	12	222	5	6	62.9
09T	4,500	6.99	20	51	7.3	142	3	3	35.7	52	90	13	250	6	6	62.9
10W	5,000	9.15	20	51	5.6	142	3	3	32.1	52	100	11	278	6	6	62.9
11T	5,500	9.52	20	51	5.4	142	3	3	29.2	52	100	11	278	6	6	57.2
12T	6,000	10.64	20	51	4.8	142	3	3	26.7	52	100	9	278	6	6	52.4
12W	6,000	11.46	20	60	5.2	167	4	3	31.5	61	100	9	278	6	6	52.4
14W	7,000	12.67	30	60	4.7	167	4	3	27.0	61	100	8	278	6	6	44.9
16T	8,000	13.73	30	60	4.4	167	4	3	23.6	61	100	7	278	6	6	39.3
17W	8,500	15.60	30	60	3.8	167	4	3	22.2	61	100	6	278	6	6	37.0
18T	9,000	15.75	30	60	3.8	167	4	3	21.0	61	100	6	278	6	6	35.0
21W	10,500	19.73	40	100	5.1	278	6	6	30.0	—	—	—	—	—	—	—
22T	11,000	20.18	40	100	5.0	278	6	6	28.6	—	—	—	—	—	—	—
25T	12,500	22.39	40	100	4.5	278	6	6	25.2	—	—	—	—	—	—	—
25W	12,500	22.05	40	100	4.5	278	6	6	25.2	—	—	—	—	—	—	—
30T	15,000	27.98	40	100	3.6	278	6	6	21.0	—	—	—	—	—	—	—
30W	15,000	28.02	40	100	3.6	278	6	6	21.0	—	—	—	—	—	—	—
35T	17,500	33.51	60	100	3.0	278	6	6	18.0	—	—	—	—	—	—	—
36W	18,000	36.51	60	100	2.7	278	6	6	17.5	—	—	—	—	—	—	—
37T	18,500	34.91	60	100	2.9	278	6	6	17.0	—	—	—	—	—	—	—
40W	20,000	40.24	60	100	2.5	278	6	6	15.7	—	—	—	—	—	—	—
42T	21,000	39.81	60	100	2.5	278	6	6	15.0	—	—	—	—	—	—	—
50W	25,000	50.61	60	100	2.0	278	6	6	12.6	—	—	—	—	—	—	—
51T	25,500	48.69	60	100	2.1	278	6	6	12.3	—	—	—	—	—	—	—
58T	29,000	55.37	60	100	1.8	278	6	6	10.8	—	—	—	—	—	—	—
61W	30,500	60.77	60	100	1.6	278	6	6	10.3	—	—	—	—	—	—	—
72W	36,000	70.32	60	120	1.7	333	7	6	10.5	—	—	—	—	—	—	—
85W	42,500	83.61	60	120	1.4	333	7	6	8.9	—	—	—	—	—	—	—
96W	48,000	94.40	60	155	1.6	431	9	6	10.2	—	—	—	—	—	—	—
110W	55,000	108.62	60	155	1.4	431	9	6	8.9	—	—	—	—	—	—	—

Electric Heater Data (cont)

39M UNIT SIZE	AIRFLOW	FACE AREA	LOW kW EH							HIGH kW EH						
			MIN kW	MAX kW	kW / SQ FT	MAX AMPS	SUB CIRCUITS AT MAX AMPS	CONTROL CIRCUITS AT MAX kW (SEE NOTE 1)	TEMP RISE AT 100% AIRFLOW	MIN kW	MAX kW	kW / SQ FT	MAX AMPS	SUB CIRCUITS AT MAX AMPS	CONTROL CIRCUITS AT MAX kW (SEE NOTE 1)	TEMP RISE AT 100% AIRFLOW
208V, ERV, Sheathed Elements, Standard Controls without Disconnect																
06W	1,500	2.46	2	15	6.1	42	1	3	31.5	—	—	—	—	—	—	—
07T	1,750	—	—	—	—	—	—	—	—	—	—	—	—	—	—	—
08W	2,000	3.57	5	20	5.6	56	2	3	31.5	—	—	—	—	—	—	—
09T	2,250	—	—	—	—	—	—	—	—	—	—	—	—	—	—	—
10W	2,500	4.91	5	25	5.1	69	2	3	31.5	—	—	—	—	—	—	—
11T	2,750	—	—	—	—	—	—	—	—	—	—	—	—	—	—	—
12T	3,000	—	—	—	—	—	—	—	—	—	—	—	—	—	—	—
12W	3,000	6.23	5	30	4.8	83	2	3	31.5	—	—	—	—	—	—	—
14W	3,500	6.88	5	35	5.1	97	3	3	31.5	—	—	—	—	—	—	—
16T	4,000	—	—	—	—	—	—	—	—	—	—	—	—	—	—	—
17W	4,250	8.21	5	45	5.5	125	3	3	33.3	—	—	—	—	—	—	—
18T	4,500	—	—	—	—	—	—	—	—	—	—	—	—	—	—	—
21W	5,250	10.28	10	50	4.9	139	3	3	30.0	—	—	—	—	—	—	—
22T	5,500	—	—	—	—	—	—	—	—	—	—	—	—	—	—	—
25T	6,250	—	—	—	—	—	—	—	—	—	—	—	—	—	—	—
25W	6,250	11.49	10	60	5.2	167	4	3	30.2	—	—	—	—	—	—	—
30T	7,500	—	—	—	—	—	—	—	—	—	—	—	—	—	—	—
30W	7,500	14.60	10	70	4.8	195	5	6	29.4	—	—	—	—	—	—	—
35T	8,750	—	—	—	—	—	—	—	—	—	—	—	—	—	—	—
36W	9,000	22.72	15	90	4.0	250	6	6	31.5	—	—	—	—	—	—	—
37T	9,250	—	—	—	—	—	—	—	—	—	—	—	—	—	—	—
40W	10,000	24.58	15	100	4.1	278	6	6	31.5	—	—	—	—	—	—	—
42T	10,500	—	—	—	—	—	—	—	—	—	—	—	—	—	—	—
50W	12,500	31.18	15	100	3.2	278	6	6	25.2	—	—	—	—	—	—	—
51T	12,750	—	—	—	—	—	—	—	—	—	—	—	—	—	—	—
58T	14,500	—	—	—	—	—	—	—	—	—	—	—	—	—	—	—
61W	15,250	32.53	15	100	3.1	278	6	6	20.6	—	—	—	—	—	—	—
72W	18,000	—	—	—	—	—	—	—	—	—	—	—	—	—	—	—
85W	21,250	—	—	—	—	—	—	—	—	—	—	—	—	—	—	—
96W	24,000	—	—	—	—	—	—	—	—	—	—	—	—	—	—	—
110W	27,500	—	—	—	—	—	—	—	—	—	—	—	—	—	—	—
208V, LFA, Open Elements, Standard Controls with Full SCR																
03W	1,500	2.66	1	16	6.0	44	1	3	33.6	17	32	12	89	2	3	67.1
06W	3,000	4.90	1	16	3.3	44	1	3	16.8	17	32	7	89	2	3	33.6
07T	3,500	7.13	1	16	2.2	44	1	3	14.4	17	32	4	89	2	3	28.8
08W	4,000	7.03	2	32	4.5	89	2	3	25.2	—	—	—	—	—	—	—
09T	4,500	7.61	2	32	4.2	89	2	3	22.4	—	—	—	—	—	—	—
10W	5,000	9.54	2	32	3.4	89	2	3	20.1	—	—	—	—	—	—	—
11T	5,500	10.26	2	32	3.1	89	2	3	18.3	—	—	—	—	—	—	—
12T	6,000	11.38	2	32	2.8	89	2	3	16.8	—	—	—	—	—	—	—
12W	6,000	11.95	2	32	2.7	89	2	3	16.8	—	—	—	—	—	—	—
14W	7,000	13.15	2	32	2.4	89	2	3	14.4	—	—	—	—	—	—	—
16T	8,000	14.60	2	32	2.2	89	2	3	12.6	—	—	—	—	—	—	—
17W	8,500	16.12	2	32	2.0	89	2	3	11.8	—	—	—	—	—	—	—
18T	9,000	16.67	2	32	1.9	89	2	3	11.2	—	—	—	—	—	—	—
21W	10,500	20.39	2	32	1.6	89	2	3	9.6	—	—	—	—	—	—	—
22T	11,000	21.18	2	32	1.5	89	2	3	9.2	—	—	—	—	—	—	—
25T	12,500	23.45	2	32	1.4	89	2	3	8.1	—	—	—	—	—	—	—
25W	12,500	22.71	2	32	1.4	89	2	3	8.1	—	—	—	—	—	—	—
30T	15,000	29.05	2	32	1.1	89	2	3	6.7	—	—	—	—	—	—	—
30W	15,000	28.68	2	32	1.1	89	2	3	6.7	—	—	—	—	—	—	—
35T	17,500	34.61	3	32	0.9	89	2	3	5.8	—	—	—	—	—	—	—
36W	18,000	37.33	3	32	0.9	89	2	3	5.6	—	—	—	—	—	—	—
37T	18,500	36.24	3	32	0.9	89	2	3	5.4	—	—	—	—	—	—	—
40W	20,000	41.14	4	32	0.8	89	2	3	5.0	—	—	—	—	—	—	—
42T	21,000	41.12	4	32	0.8	89	2	3	4.8	—	—	—	—	—	—	—
50W	25,000	51.65	4	32	0.6	89	2	3	4.0	—	—	—	—	—	—	—
51T	25,500	50.01	4	32	0.6	89	2	3	3.9	—	—	—	—	—	—	—
58T	29,000	56.87	5	32	0.6	89	2	3	3.5	—	—	—	—	—	—	—
61W	30,500	62.01	5	32	0.5	89	2	3	3.3	—	—	—	—	—	—	—
72W	36,000	71.71	5	32	0.4	89	2	3	2.8	—	—	—	—	—	—	—
85W	42,500	85.01	9	32	0.4	89	2	3	2.4	—	—	—	—	—	—	—
96W	48,000	95.98	10	32	0.3	89	2	3	2.1	—	—	—	—	—	—	—
110W	55,000	110.20	10	32	0.3	89	2	3	1.8	—	—	—	—	—	—	—



Electric Heater Data (cont)

39M UNIT SIZE	AIRFLOW	FACE AREA	LOW kW EH							HIGH kW EH						
			MIN kW	MAX kW	kW / SQ FT	MAX AMPS	SUB CIRCUITS AT MAX AMPS	CONTROL CIRCUITS AT MAX kW (SEE NOTE 1)	TEMP RISE AT 100% AIRFLOW	MIN kW	MAX kW	kW / SQ FT	MAX AMPS	SUB CIRCUITS AT MAX AMPS	CONTROL CIRCUITS AT MAX kW (SEE NOTE 1)	TEMP RISE AT 100% AIRFLOW
208V, LFA, Open Elements, Standard Controls with Vernier SCR																
03W	1,500	2.66	—	—	—	—	—	—	—	33	35	13	97	3	3	73.4
06W	3,000	4.90	—	—	—	—	—	—	—	33	48	10	133	3	3	50.3
07T	3,500	7.13	—	—	—	—	—	—	—	33	56	8	156	4	3	50.3
08W	4,000	7.03	—	—	—	—	—	—	—	33	64	9	178	4	6	50.3
09T	4,500	7.61	—	—	—	—	—	—	—	33	64	8	178	4	6	44.7
10W	5,000	9.54	—	—	—	—	—	—	—	33	64	7	178	4	6	40.3
11T	5,500	10.26	33	48	4.7	133	3	3	27.5	49	97	9	270	6	6	55.5
12T	6,000	11.38	33	48	4.2	133	3	3	25.2	49	97	9	270	6	6	50.9
12W	6,000	11.95	33	48	4.0	133	3	3	25.2	49	97	8	270	6	6	50.9
14W	7,000	13.15	33	48	3.6	133	3	3	21.6	49	97	7	270	6	6	43.6
16T	8,000	14.60	33	48	3.3	133	3	3	18.9	49	97	7	270	6	6	38.1
17W	8,500	16.12	33	48	3.0	133	3	3	17.8	49	97	6	270	6	6	35.9
18T	9,000	16.67	33	48	2.9	133	3	3	16.8	49	97	6	270	6	6	33.9
21W	10,500	20.39	33	64	3.1	178	4	6	19.2	65	100	5	278	6	6	30.0
22T	11,000	21.18	33	64	3.0	178	4	6	18.3	65	100	5	278	6	6	28.6
25T	12,500	23.45	33	64	2.7	178	4	6	16.1	65	100	4	278	6	6	25.2
25W	12,500	22.71	33	64	2.8	178	4	6	16.1	65	100	4	278	6	6	25.2
30T	15,000	29.05	33	64	2.2	178	4	6	13.4	65	100	3	278	6	6	21.0
30W	15,000	28.68	33	64	2.2	178	4	6	13.4	65	100	3	278	6	6	21.0
35T	17,500	34.61	33	64	1.8	178	4	6	11.5	65	100	3	278	6	6	18.0
36W	18,000	37.33	33	81	2.2	225	5	6	14.2	82	100	3	278	6	6	17.5
37T	18,500	36.24	33	64	1.8	178	4	6	10.9	65	100	3	278	6	6	17.0
40W	20,000	41.14	33	97	2.4	270	6	6	15.3	98	100	2	278	6	6	15.7
42T	21,000	41.12	33	64	1.6	178	4	6	9.6	65	100	2	278	6	6	15.0
50W	25,000	51.65	33	100	1.9	278	6	6	12.6	—	—	—	—	—	—	—
51T	25,500	50.01	33	100	2.0	278	6	6	12.3	—	—	—	—	—	—	—
58T	29,000	56.87	33	100	1.8	278	6	6	10.8	—	—	—	—	—	—	—
61W	30,500	62.01	33	100	1.6	278	6	6	10.3	—	—	—	—	—	—	—
72W	36,000	71.71	33	120	1.7	333	7	6	10.5	—	—	—	—	—	—	—
85W	42,500	85.01	33	120	1.4	333	7	6	8.9	—	—	—	—	—	—	—
96W	48,000	95.98	33	120	1.3	333	7	6	7.9	—	—	—	—	—	—	—
110W	55,000	110.20	33	120	1.1	333	7	6	6.9	—	—	—	—	—	—	—
208V, VAV, Open Elements, Standard Controls without Disconnect																
03W	1,500	1.33	2	9	6.8	25	1	3	18.9	—	—	—	—	—	—	—
06W	3,000	2.45	2	16	6.5	44	1	3	16.8	—	—	—	—	—	—	—
07T	3,500	3.56	2	24	6.7	67	2	3	21.6	—	—	—	—	—	—	—
08W	4,000	3.52	2	23	6.5	64	2	3	18.1	—	—	—	—	—	—	—
09T	4,500	3.81	2	25	6.6	69	2	3	17.5	—	—	—	—	—	—	—
10W	5,000	4.77	2	32	6.7	89	2	3	20.1	—	—	—	—	—	—	—
11T	5,500	5.13	2	34	6.6	94	2	3	19.4	—	—	—	—	—	—	—
12T	6,000	5.69	2	38	6.7	106	3	3	19.9	—	—	—	—	—	—	—
12W	6,000	5.97	3	40	6.7	111	3	3	21.0	—	—	—	—	—	—	—
14W	7,000	6.58	3	44	6.7	122	3	3	19.8	—	—	—	—	—	—	—
16T	8,000	7.30	2	49	6.7	136	3	3	19.3	—	—	—	—	—	—	—
17W	8,500	8.06	2	54	6.7	150	4	3	20.0	—	—	—	—	—	—	—
18T	9,000	8.33	2	55	6.6	153	4	3	19.2	—	—	—	—	—	—	—
21W	10,500	10.20	2	68	6.7	189	4	6	20.4	—	—	—	—	—	—	—
22T	11,000	10.59	2	70	6.6	195	5	6	20.0	—	—	—	—	—	—	—
25T	12,500	11.73	2	78	6.7	217	5	6	19.6	—	—	—	—	—	—	—
25W	12,500	11.36	2	76	6.7	211	5	6	19.1	—	—	—	—	—	—	—
30T	15,000	14.52	2	97	6.7	270	6	6	20.3	—	—	—	—	—	—	—
30W	15,000	14.34	2	96	6.7	267	6	6	20.1	—	—	—	—	—	—	—
35T	17,500	17.31	2	100	5.8	278	6	6	18.0	—	—	—	—	—	—	—
36W	18,000	18.67	2	100	5.4	278	6	6	17.5	—	—	—	—	—	—	—
37T	18,500	18.12	3	100	5.5	278	6	6	17.0	—	—	—	—	—	—	—
40W	20,000	20.57	2	100	4.9	278	6	6	15.7	—	—	—	—	—	—	—
42T	21,000	20.56	3	100	4.9	278	6	6	15.0	—	—	—	—	—	—	—
50W	25,000	25.83	2	100	3.9	278	6	6	12.6	—	—	—	—	—	—	—
51T	25,500	25.00	3	100	4.0	278	6	6	12.3	—	—	—	—	—	—	—
58T	29,000	28.43	3	100	3.5	278	6	6	10.8	—	—	—	—	—	—	—
61W	30,500	31.01	4	100	3.2	278	6	6	10.3	—	—	—	—	—	—	—
72W	36,000	35.86	4	120	3.3	333	7	6	10.5	—	—	—	—	—	—	—
85W	42,500	42.50	6	120	2.8	333	7	6	8.9	—	—	—	—	—	—	—
96W	48,000	47.99	6	155	3.2	431	9	6	10.2	—	—	—	—	—	—	—
110W	55,000	55.10	7	155	2.8	431	9	6	8.9	—	—	—	—	—	—	—

Physical data (cont)



Electric Heater Data (cont)

39M UNIT SIZE	AIRFLOW	FACE AREA	LOW kW EH							HIGH kW EH						
			MIN kW	MAX kW	kW / SQ FT	MAX AMPS	SUB CIRCUITS AT MAX AMPS	CONTROL CIRCUITS AT MAX kW (SEE NOTE 1)	TEMP RISE AT 100% AIRFLOW	MIN kW	MAX kW	kW / SQ FT	MAX AMPS	SUB CIRCUITS AT MAX AMPS	CONTROL CIRCUITS AT MAX kW (SEE NOTE 1)	TEMP RISE AT 100% AIRFLOW
208V, VAV, Open Elements, Standard Controls with Full SCR																
03W	1,500	1.33	1	16	12.0	44	1	3	33.6	17	25	19	69	2	3	52.4
06W	3,000	2.45	1	16	6.5	44	1	3	16.8	17	32	13	89	2	3	33.6
07T	3,500	3.56	1	16	4.5	44	1	3	14.4	17	32	9	89	2	3	28.8
08W	4,000	3.52	1	32	9.1	89	2	3	25.2	—	—	—	—	—	—	—
09T	4,500	3.81	1	32	8.4	89	2	3	22.4	—	—	—	—	—	—	—
10W	5,000	4.77	1	32	6.7	89	2	3	20.1	—	—	—	—	—	—	—
11T	5,500	5.13	1	32	6.2	89	2	3	18.3	—	—	—	—	—	—	—
12T	6,000	5.69	1	32	5.6	89	2	3	16.8	—	—	—	—	—	—	—
12W	6,000	5.97	1	32	5.4	89	2	3	16.8	—	—	—	—	—	—	—
14W	7,000	6.58	1	32	4.9	89	2	3	14.4	—	—	—	—	—	—	—
16T	8,000	7.30	1	32	4.4	89	2	3	12.6	—	—	—	—	—	—	—
17W	8,500	8.06	1	32	4.0	89	2	3	11.8	—	—	—	—	—	—	—
18T	9,000	8.33	1	32	3.8	89	2	3	11.2	—	—	—	—	—	—	—
21W	10,500	10.20	1	32	3.1	89	2	3	9.6	—	—	—	—	—	—	—
22T	11,000	10.59	2	32	3.0	89	2	3	9.2	—	—	—	—	—	—	—
25T	12,500	11.73	2	32	2.7	89	2	3	8.1	—	—	—	—	—	—	—
25W	12,500	11.36	1	32	2.8	89	2	3	8.1	—	—	—	—	—	—	—
30T	15,000	14.52	2	32	2.2	89	2	3	6.7	—	—	—	—	—	—	—
30W	15,000	14.34	1	32	2.2	89	2	3	6.7	—	—	—	—	—	—	—
35T	17,500	17.31	2	32	1.8	89	2	3	5.8	—	—	—	—	—	—	—
36W	18,000	18.67	2	32	1.7	89	2	3	5.6	—	—	—	—	—	—	—
37T	18,500	18.12	2	32	1.8	89	2	3	5.4	—	—	—	—	—	—	—
40W	20,000	20.57	2	32	1.6	89	2	3	5.0	—	—	—	—	—	—	—
42T	21,000	20.56	2	32	1.6	89	2	3	4.8	—	—	—	—	—	—	—
50W	25,000	25.83	2	32	1.2	89	2	3	4.0	—	—	—	—	—	—	—
51T	25,500	25.00	2	32	1.3	89	2	3	3.9	—	—	—	—	—	—	—
58T	29,000	28.43	2	32	1.1	89	2	3	3.5	—	—	—	—	—	—	—
61W	30,500	31.01	4	32	1.0	89	2	3	3.3	—	—	—	—	—	—	—
72W	36,000	35.86	4	32	0.9	89	2	3	2.8	—	—	—	—	—	—	—
85W	42,500	42.50	5	32	0.8	89	2	3	2.4	—	—	—	—	—	—	—
96W	48,000	47.99	5	32	0.7	89	2	3	2.1	—	—	—	—	—	—	—
110W	55,000	55.10	7	32	0.6	89	2	3	1.8	—	—	—	—	—	—	—
208V, VAV, Open Elements, Standard Controls with Vernier SCR																
06W	3,000	2.45	33	37	15.1	103	3	3	38.8	—	—	—	—	—	—	—
07T	3,500	3.56	33	56	15.7	156	4	3	50.3	—	—	—	—	—	—	—
08W	4,000	3.52	33	64	18.2	178	4	6	50.3	—	—	—	—	—	—	—
09T	4,500	3.81	33	64	16.8	178	4	6	44.7	—	—	—	—	—	—	—
10W	5,000	4.77	33	64	13.4	178	4	6	40.3	—	—	—	—	—	—	—
11T	5,500	5.13	33	48	9.4	133	3	3	27.5	49	64	12	178	4	6	36.6
12T	6,000	5.69	33	48	8.4	133	3	3	25.2	49	64	11	178	4	6	33.6
12W	6,000	5.97	33	48	8.0	133	3	3	25.2	49	64	11	178	4	6	33.6
14W	7,000	6.58	33	48	7.3	133	3	3	21.6	49	64	10	178	4	6	28.8
16T	8,000	7.30	33	48	6.6	133	3	3	18.9	49	97	13	270	6	6	38.1
17W	8,500	8.06	33	48	6.0	133	3	3	17.8	49	97	12	270	6	6	35.9
18T	9,000	8.33	33	48	5.8	133	3	3	16.8	49	97	12	270	6	6	33.9
21W	10,500	10.20	33	64	6.3	178	4	6	19.2	—	—	—	—	—	—	—
22T	11,000	10.59	33	64	6.0	178	4	6	18.3	65	97	9	270	6	6	27.7
25T	12,500	11.73	33	64	5.5	178	4	6	16.1	65	97	8	270	6	6	24.4
25W	12,500	11.36	33	64	5.6	178	4	6	16.1	—	—	—	—	—	—	—
30T	15,000	14.52	33	64	4.4	178	4	6	13.4	65	97	7	270	6	6	20.3
30W	15,000	14.34	33	64	4.5	178	4	6	13.4	—	—	—	—	—	—	—
35T	17,500	17.31	33	64	3.7	178	4	6	11.5	65	97	6	270	6	6	17.4
36W	18,000	18.67	33	81	4.3	225	5	6	14.2	82	97	5	270	6	6	17.0
37T	18,500	18.12	33	64	3.5	178	4	6	10.9	65	100	6	278	6	6	17.0
40W	20,000	20.57	33	97	4.7	270	6	6	15.3	—	—	—	—	—	—	—
42T	21,000	20.56	33	64	3.1	178	4	6	9.6	65	100	5	278	6	6	15.0
50W	25,000	25.83	33	97	3.8	270	6	6	12.2	—	—	—	—	—	—	—
51T	25,500	25.00	33	100	4.0	278	6	6	12.3	—	—	—	—	—	—	—
58T	29,000	28.43	33	100	3.5	278	6	6	10.8	—	—	—	—	—	—	—
61W	30,500	31.01	33	100	3.2	278	6	6	10.3	—	—	—	—	—	—	—
72W	36,000	35.86	33	120	3.3	333	7	6	10.5	—	—	—	—	—	—	—
85W	42,500	42.50	33	120	2.8	333	7	6	8.9	—	—	—	—	—	—	—
96W	48,000	47.99	33	155	3.2	431	9	6	10.2	—	—	—	—	—	—	—
110W	55,000	55.10	33	155	2.8	431	9	6	8.9	—	—	—	—	—	—	—



Electric Heater Data (cont)

39M UNIT SIZE	AIRFLOW	FACE AREA	LOW kW EH							HIGH kW EH						
			MIN kW	MAX kW	kW / SQ FT	MAX AMPS	SUB CIRCUITS AT MAX AMPS	CONTROL CIRCUITS AT MAX kW (SEE NOTE 1)	TEMP RISE AT 100% AIRFLOW	MIN kW	MAX kW	kW / SQ FT	MAX AMPS	SUB CIRCUITS AT MAX AMPS	CONTROL CIRCUITS AT MAX kW (SEE NOTE 1)	TEMP RISE AT 100% AIRFLOW
240V, LFA, Open Elements, Standard Controls without Disconnect																
03W	1,500	2.66	5	19	7.1	46	1	3	39.8	20	35	13	84	2	3	73.4
06W	3,000	4.90	10	59	12.0	142	3	3	61.9	60	60	12	145	4	3	62.9
07T	3,500	7.13	10	59	8.3	142	3	3	53.0	60	70	10	169	4	6	62.9
08W	4,000	7.03	20	59	8.4	142	3	3	46.4	60	80	11	193	5	6	62.9
09T	4,500	7.61	20	59	7.7	142	3	3	41.2	60	90	12	217	5	6	62.9
10W	5,000	9.54	20	59	6.2	142	3	3	37.1	60	100	10	241	6	6	62.9
11T	5,500	10.26	20	59	5.7	142	3	3	33.7	60	100	10	241	6	6	57.2
12T	6,000	11.38	20	59	5.2	142	3	3	30.9	60	100	9	241	6	6	52.4
12W	6,000	11.95	20	60	5.0	145	4	3	31.5	61	100	8	241	6	6	52.4
14W	7,000	13.15	30	60	4.6	145	4	3	27.0	61	100	8	241	6	6	44.9
16T	8,000	14.60	30	60	4.1	145	4	3	23.6	61	100	7	241	6	6	39.3
17W	8,500	16.12	30	60	3.7	145	4	3	22.2	61	100	6	241	6	6	37.0
18T	9,000	16.67	30	60	3.6	145	4	3	21.0	61	100	6	241	6	6	35.0
21W	10,500	20.39	40	100	4.9	241	6	6	30.0	—	—	—	—	—	—	—
22T	11,000	21.18	40	100	4.7	241	6	6	28.6	—	—	—	—	—	—	—
25T	12,500	23.45	40	100	4.3	241	6	6	25.2	—	—	—	—	—	—	—
25W	12,500	22.71	40	100	4.4	241	6	6	25.2	—	—	—	—	—	—	—
30T	15,000	29.05	40	100	3.4	241	6	6	21.0	—	—	—	—	—	—	—
30W	15,000	28.68	40	100	3.5	241	6	6	21.0	—	—	—	—	—	—	—
35T	17,500	34.61	60	100	2.9	241	6	6	18.0	—	—	—	—	—	—	—
36W	18,000	37.33	60	100	2.7	241	6	6	17.5	—	—	—	—	—	—	—
37T	18,500	36.24	60	100	2.8	241	6	6	17.0	—	—	—	—	—	—	—
40W	20,000	41.14	60	100	2.4	241	6	6	15.7	—	—	—	—	—	—	—
42T	21,000	41.12	60	100	2.4	241	6	6	15.0	—	—	—	—	—	—	—
50W	25,000	51.65	60	100	1.9	241	6	6	12.6	—	—	—	—	—	—	—
51T	25,500	50.01	60	100	2.0	241	6	6	12.3	—	—	—	—	—	—	—
58T	29,000	56.87	60	100	1.8	241	6	6	10.8	—	—	—	—	—	—	—
61W	30,500	62.01	60	100	1.6	241	6	6	10.3	—	—	—	—	—	—	—
72W	36,000	71.71	60	135	1.9	325	7	6	11.8	—	—	—	—	—	—	—
85W	42,500	85.01	60	135	1.6	325	7	6	10.0	—	—	—	—	—	—	—
96W	48,000	95.98	60	175	1.8	421	9	6	11.5	—	—	—	—	—	—	—
110W	55,000	110.20	60	175	1.6	421	9	6	10.0	—	—	—	—	—	—	—
240V, LFA, Sheathed Elements, Standard Controls without Disconnect																
03W	1,500	2.32	5	19	8.2	46	1	3	39.8	20	35	15	84	2	3	73.4
06W	3,000	4.55	10	59	13.0	142	3	3	61.9	60	60	13	145	4	3	62.9
07T	3,500	6.47	10	59	9.1	142	3	3	53.0	60	70	11	169	4	6	62.9
08W	4,000	6.65	20	59	8.9	142	3	3	46.4	60	80	12	193	5	6	62.9
09T	4,500	6.99	20	59	8.4	142	3	3	41.2	60	90	13	217	5	6	62.9
10W	5,000	9.15	20	59	6.4	142	3	3	37.1	60	100	11	241	6	6	62.9
11T	5,500	9.52	20	59	6.2	142	3	3	33.7	60	100	11	241	6	6	57.2
12T	6,000	10.64	20	59	5.5	142	3	3	30.9	60	100	9	241	6	6	52.4
12W	6,000	11.46	20	60	5.2	145	4	3	31.5	61	100	9	241	6	6	52.4
14W	7,000	12.67	30	60	4.7	145	4	3	27.0	61	100	8	241	6	6	44.9
16T	8,000	13.73	30	60	4.4	145	4	3	23.6	61	100	7	241	6	6	39.3
17W	8,500	15.60	30	60	3.8	145	4	3	22.2	61	100	6	241	6	6	37.0
18T	9,000	15.75	30	60	3.8	145	4	3	21.0	61	100	6	241	6	6	35.0
21W	10,500	19.73	40	100	5.1	241	6	6	30.0	—	—	—	—	—	—	—
22T	11,000	20.18	40	100	5.0	241	6	6	28.6	—	—	—	—	—	—	—
25T	12,500	22.39	40	100	4.5	241	6	6	25.2	—	—	—	—	—	—	—
25W	12,500	22.05	40	100	4.5	241	6	6	25.2	—	—	—	—	—	—	—
30T	15,000	27.98	40	100	3.6	241	6	6	21.0	—	—	—	—	—	—	—
30W	15,000	28.02	40	100	3.6	241	6	6	21.0	—	—	—	—	—	—	—
35T	17,500	33.51	60	100	3.0	241	6	6	18.0	—	—	—	—	—	—	—
36W	18,000	36.51	60	100	2.7	241	6	6	17.5	—	—	—	—	—	—	—
37T	18,500	34.91	60	100	2.9	241	6	6	17.0	—	—	—	—	—	—	—
40W	20,000	40.24	60	100	2.5	241	6	6	15.7	—	—	—	—	—	—	—
42T	21,000	39.81	60	100	2.5	241	6	6	15.0	—	—	—	—	—	—	—
50W	25,000	50.61	60	100	2.0	241	6	6	12.6	—	—	—	—	—	—	—
51T	25,500	48.69	60	100	2.1	241	6	6	12.3	—	—	—	—	—	—	—
58T	29,000	55.37	60	100	1.8	241	6	6	10.8	—	—	—	—	—	—	—
61W	30,500	60.77	60	100	1.6	241	6	6	10.3	—	—	—	—	—	—	—
72W	36,000	70.32	60	135	1.9	325	7	6	11.8	—	—	—	—	—	—	—
85W	42,500	83.61	60	135	1.6	325	7	6	10.0	—	—	—	—	—	—	—
96W	48,000	94.40	60	175	1.9	421	9	6	11.5	—	—	—	—	—	—	—
110W	55,000	108.62	60	175	1.6	421	9	6	10.0	—	—	—	—	—	—	—

Electric Heater Data (cont)

39M UNIT SIZE	AIRFLOW	FACE AREA	LOW kW EH							HIGH kW EH						
			MIN kW	MAX kW	kW / SQ FT	MAX AMPS	SUB CIRCUITS AT MAX AMPS	CONTROL CIRCUITS AT MAX kW (SEE NOTE 1)	TEMP RISE AT 100% AIRFLOW	MIN kW	MAX kW	kW / SQ FT	MAX AMPS	SUB CIRCUITS AT MAX AMPS	CONTROL CIRCUITS AT MAX kW (SEE NOTE 1)	TEMP RISE AT 100% AIRFLOW
240V, ERV, Sheathed Elements, Standard Controls without Disconnect																
03W	750	1.25	1	8	6.4	19	1	3	33.6	—	—	—	—	—	—	—
06W	1,500	2.46	2	15	6.1	36	1	3	31.5	—	—	—	—	—	—	—
07T	1,750	—	—	—	—	—	—	—	—	—	—	—	—	—	—	—
08W	2,000	3.57	5	20	5.6	48	2	3	31.5	—	—	—	—	—	—	—
09T	2,250	—	—	—	—	—	—	—	—	—	—	—	—	—	—	—
10W	2,500	4.91	5	25	5.1	60	2	3	31.5	—	—	—	—	—	—	—
11T	2,750	—	—	—	—	—	—	—	—	—	—	—	—	—	—	—
12T	3,000	—	—	—	—	—	—	—	—	—	—	—	—	—	—	—
12W	3,000	6.23	5	30	4.8	72	2	3	31.5	—	—	—	—	—	—	—
14W	3,500	6.88	5	35	5.1	84	2	3	31.5	—	—	—	—	—	—	—
16T	4,000	—	—	—	—	—	—	—	—	—	—	—	—	—	—	—
17W	4,250	8.21	5	45	5.5	108	3	3	33.3	—	—	—	—	—	—	—
18T	4,500	—	—	—	—	—	—	—	—	—	—	—	—	—	—	—
21W	5,250	10.28	10	50	4.9	120	3	3	30.0	—	—	—	—	—	—	—
22T	5,500	—	—	—	—	—	—	—	—	—	—	—	—	—	—	—
25T	6,250	—	—	—	—	—	—	—	—	—	—	—	—	—	—	—
25W	6,250	11.49	10	60	5.2	145	4	3	30.2	—	—	—	—	—	—	—
30T	7,500	—	—	—	—	—	—	—	—	—	—	—	—	—	—	—
30W	7,500	14.60	10	70	4.8	169	4	6	29.4	—	—	—	—	—	—	—
35T	8,750	—	—	—	—	—	—	—	—	—	—	—	—	—	—	—
36W	9,000	22.72	15	90	4.0	217	5	6	31.5	—	—	—	—	—	—	—
37T	9,250	—	—	—	—	—	—	—	—	—	—	—	—	—	—	—
40W	10,000	24.58	15	100	4.1	241	6	6	31.5	—	—	—	—	—	—	—
42T	10,500	—	—	—	—	—	—	—	—	—	—	—	—	—	—	—
50W	12,500	31.18	15	100	3.2	241	6	6	25.2	—	—	—	—	—	—	—
51T	12,750	—	—	—	—	—	—	—	—	—	—	—	—	—	—	—
58T	14,500	—	—	—	—	—	—	—	—	—	—	—	—	—	—	—
61W	15,250	32.53	15	100	3.1	241	6	6	20.6	—	—	—	—	—	—	—
72W	18,000	—	—	—	—	—	—	—	—	—	—	—	—	—	—	—
85W	21,250	—	—	—	—	—	—	—	—	—	—	—	—	—	—	—
96W	24,000	—	—	—	—	—	—	—	—	—	—	—	—	—	—	—
110W	27,500	—	—	—	—	—	—	—	—	—	—	—	—	—	—	—
240V, LFA, Open Elements, Standard Controls with Full SCR																
03W	1,500	2.66	1	18	6.8	43	1	3	37.7	19	35	13	84	2	3	73.4
06W	3,000	4.90	1	18	3.7	43	1	3	18.9	19	37	8	89	2	3	38.8
07T	3,500	7.13	1	37	5.2	89	2	3	33.3	—	—	—	—	—	—	—
08W	4,000	7.03	1	37	5.3	89	2	3	29.1	—	—	—	—	—	—	—
09T	4,500	7.61	1	37	4.9	89	2	3	25.9	—	—	—	—	—	—	—
10W	5,000	9.54	2	37	3.9	89	2	3	23.3	—	—	—	—	—	—	—
11T	5,500	10.26	2	37	3.6	89	2	3	21.2	—	—	—	—	—	—	—
12T	6,000	11.38	2	37	3.3	89	2	3	19.4	—	—	—	—	—	—	—
12W	6,000	11.95	2	37	3.1	89	2	3	19.4	—	—	—	—	—	—	—
14W	7,000	13.15	2	37	2.8	89	2	3	16.6	—	—	—	—	—	—	—
16T	8,000	14.60	2	37	2.5	89	2	3	14.5	—	—	—	—	—	—	—
17W	8,500	16.12	2	37	2.3	89	2	3	13.7	—	—	—	—	—	—	—
18T	9,000	16.67	2	37	2.2	89	2	3	12.9	—	—	—	—	—	—	—
21W	10,500	20.39	2	37	1.8	89	2	3	11.1	—	—	—	—	—	—	—
22T	11,000	21.18	2	37	1.7	89	2	3	10.6	—	—	—	—	—	—	—
25T	12,500	23.45	2	37	1.6	89	2	3	9.3	—	—	—	—	—	—	—
25W	12,500	22.71	2	37	1.6	89	2	3	9.3	—	—	—	—	—	—	—
30T	15,000	29.05	2	37	1.3	89	2	3	7.8	—	—	—	—	—	—	—
30W	15,000	28.68	2	37	1.3	89	2	3	7.8	—	—	—	—	—	—	—
35T	17,500	34.61	3	37	1.1	89	2	3	6.7	—	—	—	—	—	—	—
36W	18,000	37.33	3	37	1.0	89	2	3	6.5	—	—	—	—	—	—	—
37T	18,500	36.24	3	37	1.0	89	2	3	6.3	—	—	—	—	—	—	—
40W	20,000	41.14	4	37	0.9	89	2	3	5.8	—	—	—	—	—	—	—
42T	21,000	41.12	4	37	0.9	89	2	3	5.5	—	—	—	—	—	—	—
50W	25,000	51.65	4	37	0.7	89	2	3	4.7	—	—	—	—	—	—	—
51T	25,500	50.01	4	37	0.7	89	2	3	4.6	—	—	—	—	—	—	—
58T	29,000	56.87	5	37	0.7	89	2	3	4.0	—	—	—	—	—	—	—
61W	30,500	62.01	5	37	0.6	89	2	3	3.8	—	—	—	—	—	—	—
72W	36,000	71.71	5	37	0.5	89	2	3	3.2	—	—	—	—	—	—	—
85W	42,500	85.01	9	37	0.4	89	2	3	2.7	—	—	—	—	—	—	—
96W	48,000	95.98	10	37	0.4	89	2	3	2.4	—	—	—	—	—	—	—
110W	55,000	110.20	12	37	0.3	89	2	3	2.1	—	—	—	—	—	—	—

Electric Heater Data (cont)

39M UNIT SIZE	AIRFLOW	FACE AREA	LOW kW EH							HIGH kW EH						
			MIN kW	MAX kW	kW / SQ FT	MAX AMPS	SUB CIRCUITS AT MAX AMPS	CONTROL CIRCUITS AT MAX kW (SEE NOTE 1)	TEMP RISE AT 100% AIRFLOW	MIN kW	MAX kW	kW / SQ FT	MAX AMPS	SUB CIRCUITS AT MAX AMPS	CONTROL CIRCUITS AT MAX kW (SEE NOTE 1)	TEMP RISE AT 100% AIRFLOW
240V, LFA, Open Elements, Standard Controls with Vernier SCR																
03W	1,500	2.66	—	—	—	—	—	—	—	—	—	—	—	—	—	—
06W	3,000	4.90	—	—	—	—	—	—	—	38	56	11	135	3	3	58.7
07T	3,500	7.13	—	—	—	—	—	—	—	38	74	10	178	4	6	66.5
08W	4,000	7.03	—	—	—	—	—	—	—	38	74	11	178	4	6	58.2
09T	4,500	7.61	—	—	—	—	—	—	—	38	74	10	178	4	6	51.7
10W	5,000	9.54	—	—	—	—	—	—	—	38	74	8	178	4	6	46.6
11T	5,500	10.26	38	56	5.5	135	3	3	32.0	57	100	10	241	6	6	57.2
12T	6,000	11.38	38	56	4.9	135	3	3	29.4	57	100	9	241	6	6	52.4
12W	6,000	11.95	38	56	4.7	135	3	3	29.4	57	100	8	241	6	6	52.4
14W	7,000	13.15	38	56	4.3	135	3	3	25.2	57	100	8	241	6	6	44.9
16T	8,000	14.60	38	56	3.8	135	3	3	22.0	57	100	7	241	6	6	39.3
17W	8,500	16.12	38	56	3.5	135	3	3	20.7	57	100	6	241	6	6	37.0
18T	9,000	16.67	38	56	3.4	135	3	3	19.6	57	100	6	241	6	6	35.0
21W	10,500	20.39	38	74	3.6	178	4	6	22.2	75	100	5	241	6	6	30.0
22T	11,000	21.18	38	74	3.5	178	4	6	21.2	75	100	5	241	6	6	28.6
25T	12,500	23.45	38	74	3.2	178	4	6	18.6	75	100	4	241	6	6	25.2
25W	12,500	22.71	38	74	3.3	178	4	6	18.6	75	100	4	241	6	6	25.2
30T	15,000	29.05	38	74	2.5	178	4	6	15.5	75	100	3	241	6	6	21.0
30W	15,000	28.68	38	74	2.6	178	4	6	15.5	75	100	3	241	6	6	21.0
35T	17,500	34.61	38	93	2.7	224	5	6	16.7	94	100	3	241	6	6	18.0
36W	18,000	37.33	38	93	2.5	224	5	6	16.3	94	100	3	241	6	6	17.5
37T	18,500	36.24	38	93	2.6	224	5	6	15.8	94	100	3	241	6	6	17.0
40W	20,000	41.14	38	100	2.4	241	6	6	15.7	—	—	—	—	—	—	—
42T	21,000	41.12	38	100	2.4	241	6	6	15.0	—	—	—	—	—	—	—
50W	25,000	51.65	38	100	1.9	241	6	6	12.6	—	—	—	—	—	—	—
51T	25,500	50.01	38	100	2.0	241	6	6	12.3	—	—	—	—	—	—	—
58T	29,000	56.87	38	100	1.8	241	6	6	10.8	—	—	—	—	—	—	—
61W	30,500	62.01	38	100	1.6	241	6	6	10.3	—	—	—	—	—	—	—
72W	36,000	71.71	38	135	1.9	325	7	6	11.8	—	—	—	—	—	—	—
85W	42,500	85.01	38	135	1.6	325	7	6	10.0	—	—	—	—	—	—	—
96W	48,000	95.98	38	175	1.8	421	9	6	11.5	—	—	—	—	—	—	—
110W	55,000	110.20	38	175	1.6	421	9	6	10.0	—	—	—	—	—	—	—
240V, VAV, Open Elements, Standard Controls without Disconnect																
03W	1,500	1.33	2	9	6.8	22	1	3	18.9	—	—	—	—	—	—	—
06W	3,000	2.45	2	16	6.5	39	1	3	16.8	—	—	—	—	—	—	—
07T	3,500	3.56	2	24	6.7	58	2	3	21.6	—	—	—	—	—	—	—
08W	4,000	3.52	2	23	6.5	55	2	3	18.1	—	—	—	—	—	—	—
09T	4,500	3.81	2	25	6.6	60	2	3	17.5	—	—	—	—	—	—	—
10W	5,000	4.77	2	32	6.7	77	2	3	20.1	—	—	—	—	—	—	—
11T	5,500	5.13	2	34	6.6	82	2	3	19.4	—	—	—	—	—	—	—
12T	6,000	5.69	2	38	6.7	92	2	3	19.9	—	—	—	—	—	—	—
12W	6,000	5.97	3	40	6.7	96	3	3	21.0	—	—	—	—	—	—	—
14W	7,000	6.58	3	44	6.7	106	3	3	19.8	—	—	—	—	—	—	—
16T	8,000	7.30	2	49	6.7	118	3	3	19.3	—	—	—	—	—	—	—
17W	8,500	8.06	2	54	6.7	130	3	3	20.0	—	—	—	—	—	—	—
18T	9,000	8.33	2	55	6.6	132	3	3	19.2	—	—	—	—	—	—	—
21W	10,500	10.20	2	68	6.7	164	4	6	20.4	—	—	—	—	—	—	—
22T	11,000	10.59	2	70	6.6	169	4	6	20.0	—	—	—	—	—	—	—
25T	12,500	11.73	2	78	6.7	188	4	6	19.6	—	—	—	—	—	—	—
25W	12,500	11.36	2	76	6.7	183	4	6	19.1	—	—	—	—	—	—	—
30T	15,000	14.52	2	97	6.7	234	5	6	20.3	—	—	—	—	—	—	—
30W	15,000	14.34	2	96	6.7	231	5	6	20.1	—	—	—	—	—	—	—
35T	17,500	17.31	3	100	5.8	241	6	6	18.0	—	—	—	—	—	—	—
36W	18,000	18.67	2	100	5.4	241	6	6	17.5	—	—	—	—	—	—	—
37T	18,500	18.12	3	100	5.5	241	6	6	17.0	—	—	—	—	—	—	—
40W	20,000	20.57	2	100	4.9	241	6	6	15.7	—	—	—	—	—	—	—
42T	21,000	20.56	3	100	4.9	241	6	6	15.0	—	—	—	—	—	—	—
50W	25,000	25.83	2	100	3.9	241	6	6	12.6	—	—	—	—	—	—	—
51T	25,500	25.00	3	100	4.0	241	6	6	12.3	—	—	—	—	—	—	—
58T	29,000	28.43	3	100	3.5	241	6	6	10.8	—	—	—	—	—	—	—
61W	30,500	31.01	4	100	3.2	241	6	6	10.3	—	—	—	—	—	—	—
72W	36,000	35.86	4	135	3.8	325	7	6	11.8	—	—	—	—	—	—	—
85W	42,500	42.50	6	135	3.2	325	7	6	10.0	—	—	—	—	—	—	—
96W	48,000	47.99	6	175	3.6	421	9	6	11.5	—	—	—	—	—	—	—
110W	55,000	55.10	7	175	3.2	421	9	6	10.0	—	—	—	—	—	—	—

Electric Heater Data (cont)

39M UNIT SIZE	AIRFLOW	FACE AREA	LOW kW EH							HIGH kW EH						
			MIN kW	MAX kW	kW / SQ FT	MAX AMPS	SUB CIRCUITS AT MAX AMPS	CONTROL CIRCUITS AT MAX kW (SEE NOTE 1)	TEMP RISE AT 100% AIRFLOW	MIN kW	MAX kW	kW / SQ FT	MAX AMPS	SUB CIRCUITS AT MAX AMPS	CONTROL CIRCUITS AT MAX kW (SEE NOTE 1)	TEMP RISE AT 100% AIRFLOW
240V, VAV, Open Elements, Standard Controls with Full SCR																
03W	1,500	1.33	1	18	13.5	43	1	3	37.7	19	23	17	55	2	3	48.2
06W	3,000	2.45	1	18	7.3	43	1	3	18.9	19	37	15	89	2	3	38.8
07T	3,500	3.56	1	37	10.4	89	2	3	33.3	—	—	—	—	—	—	—
08W	4,000	3.52	1	37	10.5	89	2	3	29.1	—	—	—	—	—	—	—
09T	4,500	3.81	1	37	9.7	89	2	3	25.9	—	—	—	—	—	—	—
10W	5,000	4.77	1	37	7.8	89	2	3	23.3	—	—	—	—	—	—	—
11T	5,500	5.13	1	37	7.2	89	2	3	21.2	—	—	—	—	—	—	—
12T	6,000	5.69	1	37	6.5	89	2	3	19.4	—	—	—	—	—	—	—
12W	6,000	5.97	1	37	6.2	89	2	3	19.4	—	—	—	—	—	—	—
14W	7,000	6.58	1	37	5.6	89	2	3	16.6	—	—	—	—	—	—	—
16T	8,000	7.30	1	37	5.1	89	2	3	14.5	—	—	—	—	—	—	—
17W	8,500	8.06	1	37	4.6	89	2	3	13.7	—	—	—	—	—	—	—
18T	9,000	8.33	1	37	4.4	89	2	3	12.9	—	—	—	—	—	—	—
21W	10,500	10.20	1	37	3.6	89	2	3	11.1	—	—	—	—	—	—	—
22T	11,000	10.59	2	37	3.5	89	2	3	10.6	—	—	—	—	—	—	—
25T	12,500	11.73	2	37	3.2	89	2	3	9.3	—	—	—	—	—	—	—
25W	12,500	11.36	1	37	3.3	89	2	3	9.3	—	—	—	—	—	—	—
30T	15,000	14.52	2	37	2.5	89	2	3	7.8	—	—	—	—	—	—	—
30W	15,000	14.34	1	37	2.6	89	2	3	7.8	—	—	—	—	—	—	—
35T	17,500	17.31	2	37	2.1	89	2	3	6.7	—	—	—	—	—	—	—
36W	18,000	18.67	2	37	2.0	89	2	3	6.5	—	—	—	—	—	—	—
37T	18,500	18.12	2	37	2.0	89	2	3	6.3	—	—	—	—	—	—	—
40W	20,000	20.57	2	37	1.8	89	2	3	5.8	—	—	—	—	—	—	—
42T	21,000	20.56	2	37	1.8	89	2	3	5.5	—	—	—	—	—	—	—
50W	25,000	25.83	2	37	1.4	89	2	3	4.7	—	—	—	—	—	—	—
51T	25,500	25.00	2	37	1.5	89	2	3	4.6	—	—	—	—	—	—	—
58T	29,000	28.43	3	37	1.3	89	2	3	4.0	—	—	—	—	—	—	—
61W	30,500	31.01	3	37	1.2	89	2	3	3.8	—	—	—	—	—	—	—
72W	36,000	35.86	3	37	1.0	89	2	3	3.2	—	—	—	—	—	—	—
85W	42,500	42.50	5	37	0.9	89	2	3	2.7	—	—	—	—	—	—	—
96W	48,000	47.99	5	37	0.8	89	2	3	2.4	—	—	—	—	—	—	—
110W	55,000	55.10	6	37	0.7	89	2	3	2.1	—	—	—	—	—	—	—
240V, VAV, Open Elements, Standard Controls with Vernier SCR																
07T	3,500	3.56	38	74	20.8	178	4	6	66.5	—	—	—	—	—	—	—
08W	4,000	3.52	38	51	14.5	123	3	3	40.1	—	—	—	—	—	—	—
09T	4,500	3.81	38	74	19.4	178	4	6	51.7	—	—	—	—	—	—	—
10W	5,000	4.77	38	74	15.5	178	4	6	46.6	—	—	—	—	—	—	—
11T	5,500	5.13	38	56	10.9	135	3	3	32.0	57	74	14	178	4	6	42.3
12T	6,000	5.69	38	56	9.8	135	3	3	29.4	57	74	13	178	4	6	38.8
12W	6,000	5.97	38	56	9.4	135	3	3	29.4	57	74	12	178	4	6	38.8
14W	7,000	6.58	38	56	8.5	135	3	3	25.2	57	74	11	178	4	6	33.3
16T	8,000	7.30	38	56	7.7	135	3	3	22.0	57	100	14	241	6	6	39.3
17W	8,500	8.06	38	56	6.9	135	3	3	20.7	57	100	12	241	6	6	37.0
18T	9,000	8.33	38	56	6.7	135	3	3	19.6	57	100	12	241	6	6	35.0
21W	10,500	10.20	38	74	7.3	178	4	6	22.2	—	—	—	—	—	—	—
22T	11,000	10.59	38	74	7.0	178	4	6	21.2	75	100	9	241	6	6	28.6
25T	12,500	11.73	38	74	6.3	178	4	6	18.6	75	100	9	241	6	6	25.2
25W	12,500	11.36	38	74	6.5	178	4	6	18.6	—	—	—	—	—	—	—
30T	15,000	14.52	38	74	5.1	178	4	6	15.5	75	100	7	241	6	6	21.0
30W	15,000	14.34	38	74	5.2	178	4	6	15.5	—	—	—	—	—	—	—
35T	17,500	17.31	38	93	5.4	224	5	6	16.7	94	100	6	241	6	6	18.0
36W	18,000	18.67	38	93	5.0	224	5	6	16.3	94	100	5	241	6	6	17.5
37T	18,500	18.12	38	93	5.1	224	5	6	15.8	94	100	6	241	6	6	17.0
40W	20,000	20.57	38	100	4.9	241	6	6	15.7	—	—	—	—	—	—	—
42T	21,000	20.56	38	100	4.9	241	6	6	15.0	—	—	—	—	—	—	—
50W	25,000	25.83	38	100	3.9	241	6	6	12.6	—	—	—	—	—	—	—
51T	25,500	25.00	38	100	4.0	241	6	6	12.3	—	—	—	—	—	—	—
58T	29,000	28.43	38	100	3.5	241	6	6	10.8	—	—	—	—	—	—	—
61W	30,500	31.01	38	100	3.2	241	6	6	10.3	—	—	—	—	—	—	—
72W	36,000	35.86	38	135	3.8	325	7	6	11.8	—	—	—	—	—	—	—
85W	42,500	42.50	38	135	3.2	325	7	6	10.0	—	—	—	—	—	—	—
96W	48,000	47.99	38	175	3.6	421	9	6	11.5	—	—	—	—	—	—	—
110W	55,000	55.10	38	175	3.2	421	9	6	10.0	—	—	—	—	—	—	—



Electric Heater Data (cont)

39M UNIT SIZE	AIRFLOW	FACE AREA	LOW kW EH							HIGH kW EH						
			MIN kW	MAX kW	kW / SQ FT	MAX AMPS	SUB CIRCUITS AT MAX AMPS	CONTROL CIRCUITS AT MAX kW (SEE NOTE 1)	TEMP RISE AT 100% AIRFLOW	MIN kW	MAX kW	kW / SQ FT	MAX AMPS	SUB CIRCUITS AT MAX AMPS	CONTROL CIRCUITS AT MAX kW (SEE NOTE 1)	TEMP RISE AT 100% AIRFLOW
380V, LFA, Open Elements, Standard Controls without Disconnect																
03W	1,500	2.66	5	31	11.6	47	1	3	65.0	32	35	13	53	2	3	73.4
06W	3,000	4.90	10	31	6.3	47	1	3	32.5	32	60	12	91	2	3	62.9
07T	3,500	7.13	10	50	7.0	76	2	3	44.9	51	70	10	106	3	6	62.9
08W	4,000	7.03	20	60	8.5	91	2	3	47.2	61	80	11	122	3	6	62.9
09T	4,500	7.61	20	60	7.9	91	2	3	41.9	61	90	12	137	3	6	62.9
10W	5,000	9.54	20	60	6.3	91	2	3	37.7	61	94	10	143	3	6	59.1
11T	5,500	10.26	20	70	6.8	106	3	6	40.0	71	110	11	167	4	6	62.9
12T	6,000	11.38	20	80	7.0	122	3	6	41.9	81	120	11	183	4	6	62.9
12W	6,000	11.95	20	92	7.7	140	3	6	48.2	93	130	11	198	5	6	68.2
14W	7,000	13.15	30	92	7.0	140	3	6	41.3	93	150	11	228	5	6	67.4
16T	8,000	14.60	30	93	6.4	141	3	6	36.6	94	160	11	243	6	6	62.9
17W	8,500	16.12	30	94	5.8	143	3	6	34.8	95	175	11	266	6	6	64.8
18T	9,000	16.67	30	93	5.6	141	3	6	32.5	94	175	11	266	6	6	61.2
21W	10,500	20.39	40	94	4.6	143	3	6	28.2	95	220	11	335	7	6	65.9
22T	11,000	21.18	40	94	4.4	143	3	6	26.9	95	230	11	350	8	6	65.8
25T	12,500	23.45	40	94	4.0	143	3	6	23.7	95	250	11	380	8	6	62.9
25W	12,500	22.71	40	94	4.1	143	3	6	23.7	95	250	11	380	8	6	62.9
30T	15,000	29.05	40	94	3.2	143	3	6	19.7	95	250	9	380	8	6	52.4
30W	15,000	28.68	40	94	3.3	143	3	6	19.7	95	252	9	383	8	6	52.8
35T	17,500	34.61	60	94	2.7	143	3	6	16.9	95	252	7	383	8	6	45.3
36W	18,000	37.33	60	94	2.5	143	3	6	16.4	90	252	7	383	8	6	44.0
37T	18,500	36.24	60	94	2.6	143	3	6	16.0	95	252	7	383	8	6	42.8
40W	20,000	41.14	60	189	4.6	287	6	6	29.7	90	252	6	383	8	6	39.6
42T	21,000	41.12	60	189	4.6	287	6	6	28.3	190	252	6	383	8	6	37.7
50W	25,000	51.65	60	200	3.9	304	7	6	25.2	201	252	5	383	8	6	31.7
51T	25,500	50.01	60	200	4.0	304	7	6	24.7	201	252	5	383	8	6	31.1
58T	29,000	56.87	60	252	4.4	383	8	6	27.3	—	—	—	—	—	—	—
61W	30,500	62.01	60	252	4.1	383	8	6	26.0	—	—	—	—	—	—	—
72W	36,000	71.71	60	252	3.5	383	8	6	22.0	—	—	—	—	—	—	—
85W	42,500	85.01	60	252	3.0	383	8	6	18.7	—	—	—	—	—	—	—
96W	48,000	95.98	60	280	2.9	426	9	6	18.3	—	—	—	—	—	—	—
110W	55,000	110.20	60	280	2.5	426	9	6	16.0	—	—	—	—	—	—	—
380V, LFA, Sheathed Elements, Standard Controls without Disconnect																
03W	1,500	2.32	5	31	13.4	47	1	3	65.0	32	35	15	53	2	3	73.4
06W	3,000	4.55	10	31	6.8	47	1	3	32.5	32	60	13	91	2	3	62.9
07T	3,500	6.47	10	50	7.7	76	2	3	44.9	51	70	11	106	3	6	62.9
08W	4,000	6.65	20	60	9.0	91	2	3	47.2	61	80	12	122	3	6	62.9
09T	4,500	6.99	20	60	8.6	91	2	3	41.9	61	90	13	137	3	6	62.9
10W	5,000	9.15	20	60	6.6	91	2	3	37.7	61	94	10	143	3	6	59.1
11T	5,500	9.52	20	70	7.4	106	3	6	40.0	71	110	12	167	4	6	62.9
12T	6,000	10.64	20	80	7.5	122	3	6	41.9	81	120	11	183	4	6	62.9
12W	6,000	11.46	20	92	8.0	140	3	6	48.2	93	130	11	198	5	6	68.2
14W	7,000	12.67	30	92	7.3	140	3	6	41.3	93	150	12	228	5	6	67.4
16T	8,000	13.73	30	93	6.8	141	3	6	36.6	94	160	12	243	6	6	62.9
17W	8,500	15.60	30	94	6.0	143	3	6	34.8	95	175	11	266	6	6	64.8
18T	9,000	15.75	30	93	5.9	141	3	6	32.5	94	175	11	266	6	6	61.2
21W	10,500	19.73	40	94	4.8	143	3	6	28.2	95	220	11	335	7	6	65.9
22T	11,000	20.18	40	94	4.7	143	3	6	26.9	95	230	11	350	8	6	65.8
25T	12,500	22.39	40	94	4.2	143	3	6	23.7	95	250	11	380	8	6	62.9
25W	12,500	22.05	40	94	4.3	143	3	6	23.7	95	250	11	380	8	6	62.9
30T	15,000	27.98	40	94	3.4	143	3	6	19.7	95	250	9	380	8	6	52.4
30W	15,000	28.02	40	94	3.4	143	3	6	19.7	95	252	9	383	8	6	52.8
35T	17,500	33.51	60	94	2.8	143	3	6	16.9	95	252	8	383	8	6	45.3
36W	18,000	36.51	60	94	2.6	143	3	6	16.4	90	252	7	383	8	6	44.0
37T	18,500	34.91	60	94	2.7	143	3	6	16.0	95	252	7	383	8	6	42.8
40W	20,000	40.24	60	189	4.7	287	6	6	29.7	90	252	6	383	8	6	39.6
42T	21,000	39.81	60	189	4.7	287	6	6	28.3	190	252	6	383	8	6	37.7
50W	25,000	50.61	60	200	4.0	304	7	6	25.2	201	252	5	383	8	6	31.7
51T	25,500	48.69	60	200	4.1	304	7	6	24.7	201	252	5	383	8	6	31.1
58T	29,000	55.37	60	252	4.6	383	8	6	27.3	—	—	—	—	—	—	—
61W	30,500	60.77	60	252	4.1	383	8	6	26.0	—	—	—	—	—	—	—
72W	36,000	70.32	60	252	3.6	383	8	6	22.0	—	—	—	—	—	—	—
85W	42,500	83.61	60	252	3.0	383	8	6	18.7	—	—	—	—	—	—	—
96W	48,000	94.40	60	280	3.0	426	9	6	18.3	—	—	—	—	—	—	—
110W	55,000	108.62	60	280	2.6	426	9	6	16.0	—	—	—	—	—	—	—

Electric Heater Data (cont)

39M UNIT SIZE	AIRFLOW	FACE AREA	LOW kW EH							HIGH kW EH						
			MIN kW	MAX kW	kW / SQ FT	MAX AMPS	SUB CIRCUITS AT MAX AMPS	CONTROL CIRCUITS AT MAX kW (SEE NOTE 1)	TEMP RISE AT 100% AIRFLOW	MIN kW	MAX kW	kW / SQ FT	MAX AMPS	SUB CIRCUITS AT MAX AMPS	CONTROL CIRCUITS AT MAX kW (SEE NOTE 1)	TEMP RISE AT 100% AIRFLOW
380V, ERV, Sheathed Elements, Standard Controls without Disconnect																
03W	750	1.25	1	8	6.4	12	1	3	33.6	—	—	—	—	—	—	—
06W	1,500	2.46	2	15	6.1	23	1	3	31.5	—	—	—	—	—	—	—
07T	1,750	—	—	—	—	—	—	—	—	—	—	—	—	—	—	—
08W	2,000	3.57	5	20	5.6	30	1	3	31.5	—	—	—	—	—	—	—
09T	2,250	—	—	—	—	—	—	—	—	—	—	—	—	—	—	—
10W	2,500	4.91	5	25	5.1	38	1	3	31.5	—	—	—	—	—	—	—
11T	2,750	—	—	—	—	—	—	—	—	—	—	—	—	—	—	—
12T	3,000	—	—	—	—	—	—	—	—	—	—	—	—	—	—	—
12W	3,000	6.23	5	30	4.8	46	1	3	31.5	—	—	—	—	—	—	—
14W	3,500	6.88	5	35	5.1	53	2	3	31.5	—	—	—	—	—	—	—
16T	4,000	—	—	—	—	—	—	—	—	—	—	—	—	—	—	—
17W	4,250	8.21	5	45	5.5	68	2	3	33.3	—	—	—	—	—	—	—
18T	4,500	—	—	—	—	—	—	—	—	—	—	—	—	—	—	—
21W	5,250	10.28	10	50	4.9	76	2	3	30.0	—	—	—	—	—	—	—
22T	5,500	—	—	—	—	—	—	—	—	—	—	—	—	—	—	—
25T	6,250	—	—	—	—	—	—	—	—	—	—	—	—	—	—	—
25W	6,250	11.49	10	60	5.2	91	2	3	30.2	—	—	—	—	—	—	—
30T	7,500	—	—	—	—	—	—	—	—	—	—	—	—	—	—	—
30W	7,500	14.60	10	70	4.8	106	3	6	29.4	—	—	—	—	—	—	—
35T	8,750	—	—	—	—	—	—	—	—	—	—	—	—	—	—	—
36W	9,000	22.72	15	90	4.0	137	3	6	31.5	—	—	—	—	—	—	—
37T	9,250	—	—	—	—	—	—	—	—	—	—	—	—	—	—	—
40W	10,000	24.58	15	100	4.1	152	4	6	31.5	—	—	—	—	—	—	—
42T	10,500	—	—	—	—	—	—	—	—	—	—	—	—	—	—	—
50W	12,500	31.18	15	125	4.0	190	4	6	31.5	—	—	—	—	—	—	—
51T	12,750	—	—	—	—	—	—	—	—	—	—	—	—	—	—	—
58T	14,500	—	—	—	—	—	—	—	—	—	—	—	—	—	—	—
61W	15,250	32.53	15	150	4.6	228	5	6	30.9	—	—	—	—	—	—	—
72W	18,000	—	—	—	—	—	—	—	—	—	—	—	—	—	—	—
85W	21,250	—	—	—	—	—	—	—	—	—	—	—	—	—	—	—
96W	24,000	—	—	—	—	—	—	—	—	—	—	—	—	—	—	—
110W	27,500	—	—	—	—	—	—	—	—	—	—	—	—	—	—	—
380V, LFA, Open Elements, Standard Controls with Full SCR																
03W	1,500	2.66	1	29	10.9	44	1	3	60.8	30	35	13	53	2	3	73.4
06W	3,000	4.90	1	29	5.9	44	1	3	30.4	30	59	12	90	2	3	61.9
07T	3,500	7.13	2	29	4.1	44	1	3	26.1	30	59	8	90	2	3	53.0
08W	4,000	7.03	1	29	4.1	44	1	3	22.8	30	59	8	90	2	3	46.4
09T	4,500	7.61	2	29	3.8	44	1	3	20.3	30	59	8	90	2	3	41.2
10W	5,000	9.54	2	29	3.0	44	1	3	18.2	30	59	6	90	2	3	37.1
11T	5,500	10.26	2	59	5.7	90	2	3	33.7	—	—	—	—	—	—	—
12T	6,000	11.38	2	59	5.2	90	2	3	30.9	—	—	—	—	—	—	—
12W	6,000	11.95	2	59	4.9	90	2	3	30.9	—	—	—	—	—	—	—
14W	7,000	13.15	2	59	4.5	90	2	3	26.5	—	—	—	—	—	—	—
16T	8,000	14.60	2	59	4.0	90	2	3	23.2	—	—	—	—	—	—	—
17W	8,500	16.12	2	59	3.7	90	2	3	21.8	—	—	—	—	—	—	—
18T	9,000	16.67	2	59	3.5	90	2	3	20.6	—	—	—	—	—	—	—
21W	10,500	20.39	3	59	2.9	90	2	3	17.7	—	—	—	—	—	—	—
22T	11,000	21.18	3	59	2.8	90	2	3	16.9	—	—	—	—	—	—	—
25T	12,500	23.45	3	59	2.5	90	2	3	14.8	—	—	—	—	—	—	—
25W	12,500	22.71	3	59	2.6	90	2	3	14.8	—	—	—	—	—	—	—
30T	15,000	29.05	3	59	2.0	90	2	3	12.4	—	—	—	—	—	—	—
30W	15,000	28.68	3	59	2.1	90	2	3	12.4	—	—	—	—	—	—	—
35T	17,500	34.61	4	59	1.7	90	2	3	10.6	—	—	—	—	—	—	—
36W	18,000	37.33	4	59	1.6	90	2	3	10.3	—	—	—	—	—	—	—
37T	18,500	36.24	4	59	1.6	90	2	3	10.0	—	—	—	—	—	—	—
40W	20,000	41.14	4	59	1.4	90	2	3	9.3	—	—	—	—	—	—	—
42T	21,000	41.12	4	59	1.4	90	2	3	8.8	—	—	—	—	—	—	—
50W	25,000	51.65	5	59	1.1	90	2	3	7.4	—	—	—	—	—	—	—
51T	25,500	50.01	5	59	1.2	90	2	3	7.3	—	—	—	—	—	—	—
58T	29,000	56.87	6	59	1.0	90	2	3	6.4	—	—	—	—	—	—	—
61W	30,500	62.01	6	59	1.0	90	2	3	6.1	—	—	—	—	—	—	—
72W	36,000	71.71	7	59	0.8	90	2	3	5.2	—	—	—	—	—	—	—
85W	42,500	85.01	7	59	0.7	90	2	3	4.4	—	—	—	—	—	—	—
96W	48,000	95.98	10	59	0.6	90	2	3	3.9	—	—	—	—	—	—	—
110W	55,000	110.20	10	59	0.5	90	2	3	3.4	—	—	—	—	—	—	—

Electric Heater Data (cont)

39M UNIT SIZE	AIRFLOW	FACE AREA	LOW kW EH							HIGH kW EH						
			MIN kW	MAX kW	kW / SQ FT	MAX AMPS	SUB CIRCUITS AT MAX AMPS	CONTROL CIRCUITS AT MAX kW (SEE NOTE 1)	TEMP RISE AT 100% AIRFLOW	MIN kW	MAX kW	kW / SQ FT	MAX AMPS	SUB CIRCUITS AT MAX AMPS	CONTROL CIRCUITS AT MAX kW (SEE NOTE 1)	TEMP RISE AT 100% AIRFLOW
380V, LFA, Open Elements, Standard Controls with Vernier SCR																
03W	1,500	2.66	—	—	—	—	—	—	—	—	—	—	—	—	—	—
06W	3,000	4.90	—	—	—	—	—	—	—	—	—	—	—	—	—	—
07T	3,500	7.13	—	—	—	—	—	—	—	60	80	11	122	3	6	71.9
08W	4,000	7.03	—	—	—	—	—	—	—	60	80	11	122	3	6	62.9
09T	4,500	7.61	—	—	—	—	—	—	—	60	94	12	143	3	6	65.7
10W	5,000	9.54	—	—	—	—	—	—	—	60	94	10	143	3	6	59.1
11T	5,500	10.26	—	—	—	—	—	—	—	60	130	13	198	5	6	74.4
12T	6,000	11.38	—	—	—	—	—	—	—	60	130	11	198	5	6	68.2
12W	6,000	11.95	—	—	—	—	—	—	—	60	130	11	198	5	6	68.2
14W	7,000	13.15	—	—	—	—	—	—	—	60	148	11	225	5	6	66.5
16T	8,000	14.60	—	—	—	—	—	—	—	60	148	10	225	5	6	58.2
17W	8,500	16.12	—	—	—	—	—	—	—	60	148	9	225	5	6	54.8
18T	9,000	16.67	—	—	—	—	—	—	—	60	148	9	225	5	6	51.7
21W	10,500	20.39	60	88	4.3	134	3	6	26.4	89	177	9	269	6	6	53.0
22T	11,000	21.18	60	88	4.2	134	3	6	25.2	89	177	8	269	6	6	50.6
25T	12,500	23.45	60	88	3.8	134	3	6	22.1	89	177	8	269	6	6	44.5
25W	12,500	22.71	60	88	3.9	134	3	6	22.1	89	177	8	269	6	6	44.5
30T	15,000	29.05	60	88	3.0	134	3	6	18.5	89	177	6	269	6	6	37.1
30W	15,000	28.68	60	88	3.1	134	3	6	18.5	89	177	6	269	6	6	37.1
35T	17,500	34.61	60	118	3.4	179	4	6	21.2	119	236	7	359	8	6	42.4
36W	18,000	37.33	60	118	3.2	179	4	6	20.6	119	236	6	359	8	6	41.2
37T	18,500	36.24	60	118	3.3	179	4	6	20.1	119	236	7	359	8	6	40.1
40W	20,000	41.14	60	118	2.9	179	4	6	18.6	119	252	6	383	8	6	39.6
42T	21,000	41.12	60	118	2.9	179	4	6	17.7	119	252	6	383	8	6	37.7
50W	25,000	51.65	60	148	2.9	225	5	6	18.6	149	252	5	383	8	6	31.7
51T	25,500	50.01	60	177	3.5	269	6	6	21.8	178	252	5	383	8	6	31.1
58T	29,000	56.87	60	177	3.1	269	6	6	19.2	178	252	4	383	8	6	27.3
61W	30,500	62.01	60	177	2.9	269	6	6	18.3	178	252	4	383	8	6	26.0
72W	36,000	71.71	60	207	2.9	315	7	6	18.1	208	252	4	383	8	6	22.0
85W	42,500	85.01	60	207	2.4	315	7	6	15.3	208	252	3	383	8	6	18.7
96W	48,000	95.98	60	236	2.5	359	8	6	15.5	237	252	3	383	8	6	16.5
110W	55,000	110.20	60	236	2.1	359	8	6	13.5	237	252	2	383	8	6	14.4
380V, VAV, Open Elements, Standard Controls without Disconnect																
03W	1,500	1.33	3	9	6.8	14	1	3	18.9	—	—	—	—	—	—	—
06W	3,000	2.45	3	16	6.5	24	1	3	16.8	—	—	—	—	—	—	—
07T	3,500	3.56	3	24	6.7	37	1	3	21.6	—	—	—	—	—	—	—
08W	4,000	3.52	3	23	6.5	35	1	3	18.1	—	—	—	—	—	—	—
09T	4,500	3.81	3	25	6.6	38	1	3	17.5	—	—	—	—	—	—	—
10W	5,000	4.77	3	32	6.7	49	2	3	20.1	—	—	—	—	—	—	—
11T	5,500	5.13	3	34	6.6	52	2	3	19.4	—	—	—	—	—	—	—
12T	6,000	5.69	3	38	6.7	58	2	3	19.9	—	—	—	—	—	—	—
12W	6,000	5.97	5	40	6.7	61	2	3	21.0	—	—	—	—	—	—	—
14W	7,000	6.58	5	44	6.7	67	2	3	19.8	—	—	—	—	—	—	—
16T	8,000	7.30	3	49	6.7	75	2	3	19.3	—	—	—	—	—	—	—
17W	8,500	8.06	3	54	6.7	82	2	3	20.0	—	—	—	—	—	—	—
18T	9,000	8.33	3	55	6.6	84	2	3	19.2	—	—	—	—	—	—	—
21W	10,500	10.20	3	68	6.7	103	3	6	20.4	—	—	—	—	—	—	—
22T	11,000	10.59	3	70	6.6	106	3	6	20.0	—	—	—	—	—	—	—
25T	12,500	11.73	3	78	6.7	119	3	6	19.6	—	—	—	—	—	—	—
25W	12,500	11.36	3	76	6.7	116	3	6	19.1	—	—	—	—	—	—	—
30T	15,000	14.52	3	94	6.5	143	3	6	19.7	95	97	7	148	4	6	20.3
30W	15,000	14.34	3	94	6.6	143	3	6	19.7	95	96	7	146	4	6	20.1
35T	17,500	17.31	3	94	5.4	143	3	6	16.9	95	115	7	175	4	6	20.7
36W	18,000	18.67	3	94	5.0	143	3	6	16.4	95	124	7	189	4	6	21.7
37T	18,500	18.12	5	94	5.2	143	3	6	16.0	95	120	7	183	4	6	20.4
40W	20,000	20.57	3	137	6.7	208	5	6	21.5	—	—	—	—	—	—	—
42T	21,000	20.56	5	137	6.7	208	5	6	20.5	—	—	—	—	—	—	—
50W	25,000	25.83	3	172	6.7	262	6	6	21.6	—	—	—	—	—	—	—
51T	25,500	25.00	5	166	6.6	253	6	6	20.5	—	—	—	—	—	—	—
58T	29,000	28.43	5	189	6.6	287	6	6	20.5	—	—	—	—	—	—	—
61W	30,500	31.01	5	206	6.6	313	7	6	21.2	—	—	—	—	—	—	—
72W	36,000	35.86	5	238	6.6	362	8	6	20.8	—	—	—	—	—	—	—
85W	42,500	42.50	5	252	5.9	383	8	6	18.7	—	—	—	—	—	—	—
96W	48,000	47.99	5	280	5.8	426	9	6	18.3	—	—	—	—	—	—	—
110W	55,000	55.10	5	280	5.1	426	9	6	16.0	—	—	—	—	—	—	—

Electric Heater Data (cont)

39M UNIT SIZE	AIRFLOW	FACE AREA	LOW kW EH							HIGH kW EH						
			MIN kW	MAX kW	kW / SQ FT	MAX AMPS	SUB CIRCUITS AT MAX AMPS	CONTROL CIRCUITS AT MAX kW (SEE NOTE 1)	TEMP RISE AT 100% AIRFLOW	MIN kW	MAX kW	kW / SQ FT	MAX AMPS	SUB CIRCUITS AT MAX AMPS	CONTROL CIRCUITS AT MAX kW (SEE NOTE 1)	TEMP RISE AT 100% AIRFLOW
380V, VAV, Open Elements, Standard Controls with Full SCR																
03W	1,500	1.33	1	21	15.8	32	1	3	44.0	—	—	—	—	—	—	—
06W	3,000	2.45	1	29	11.8	44	1	3	30.4	30	54	22	82	2	3	56.6
07T	3,500	3.56	1	29	8.1	44	1	3	26.1	30	59	17	90	2	3	53.0
08W	4,000	3.52	1	29	8.2	44	1	3	22.8	30	59	17	90	2	3	46.4
09T	4,500	3.81	1	29	7.6	44	1	3	20.3	30	59	15	90	2	3	41.2
10W	5,000	4.77	1	29	6.1	44	1	3	18.2	30	59	12	90	2	3	37.1
11T	5,500	5.13	1	59	11.5	90	2	3	33.7	—	—	—	—	—	—	—
12T	6,000	5.69	1	59	10.4	90	2	3	30.9	—	—	—	—	—	—	—
12W	6,000	5.97	2	59	9.9	90	2	3	30.9	—	—	—	—	—	—	—
14W	7,000	6.58	2	59	9.0	90	2	3	26.5	—	—	—	—	—	—	—
16T	8,000	7.30	1	59	8.1	90	2	3	23.2	—	—	—	—	—	—	—
17W	8,500	8.06	2	59	7.3	90	2	3	21.8	—	—	—	—	—	—	—
18T	9,000	8.33	1	59	7.1	90	2	3	20.6	—	—	—	—	—	—	—
21W	10,500	10.20	2	59	5.8	90	2	3	17.7	—	—	—	—	—	—	—
22T	11,000	10.59	2	59	5.6	90	2	3	16.9	—	—	—	—	—	—	—
25T	12,500	11.73	2	59	5.0	90	2	3	14.8	—	—	—	—	—	—	—
25W	12,500	11.36	2	59	5.2	90	2	3	14.8	—	—	—	—	—	—	—
30T	15,000	14.52	3	59	4.1	90	2	3	12.4	—	—	—	—	—	—	—
30W	15,000	14.34	2	59	4.1	90	2	3	12.4	—	—	—	—	—	—	—
35T	17,500	17.31	3	59	3.4	90	2	3	10.6	—	—	—	—	—	—	—
36W	18,000	18.67	2	59	3.2	90	2	3	10.3	—	—	—	—	—	—	—
37T	18,500	18.12	3	59	3.3	90	2	3	10.0	—	—	—	—	—	—	—
40W	20,000	20.57	2	59	2.9	90	2	3	9.3	—	—	—	—	—	—	—
42T	21,000	20.56	3	59	2.9	90	2	3	8.8	—	—	—	—	—	—	—
50W	25,000	25.83	3	59	2.3	90	2	3	7.4	—	—	—	—	—	—	—
51T	25,500	25.00	3	59	2.4	90	2	3	7.3	—	—	—	—	—	—	—
58T	29,000	28.43	3	59	2.1	90	2	3	6.4	—	—	—	—	—	—	—
61W	30,500	31.01	3	59	1.9	90	2	3	6.1	—	—	—	—	—	—	—
72W	36,000	35.86	4	59	1.6	90	2	3	5.2	—	—	—	—	—	—	—
85W	42,500	42.50	4	59	1.4	90	2	3	4.4	—	—	—	—	—	—	—
96W	48,000	47.99	4	59	1.2	90	2	3	3.9	—	—	—	—	—	—	—
110W	55,000	55.10	5	59	1.1	90	2	3	3.4	—	—	—	—	—	—	—
380V, VAV, Open Elements, Standard Controls with Vernier SCR																
10W	5,000	4.77	60	68	14.3	103	3	6	42.8	—	—	—	—	—	—	—
11T	5,500	5.13	60	118	23.0	179	4	6	67.5	—	—	—	—	—	—	—
12T	6,000	5.69	60	118	20.7	179	4	6	61.9	—	—	—	—	—	—	—
12W	6,000	5.97	60	118	19.8	179	4	6	61.9	—	—	—	—	—	—	—
14W	7,000	6.58	60	118	17.9	179	4	6	53.0	—	—	—	—	—	—	—
16T	8,000	7.30	60	148	20.3	225	5	6	58.2	—	—	—	—	—	—	—
17W	8,500	8.06	60	148	18.4	225	5	6	54.8	—	—	—	—	—	—	—
18T	9,000	8.33	60	148	17.8	225	5	6	51.7	—	—	—	—	—	—	—
21W	10,500	10.20	60	88	8.6	134	3	6	26.4	89	118	12	179	4	6	35.4
22T	11,000	10.59	60	88	8.3	134	3	6	25.2	89	177	17	269	6	6	50.6
25T	12,500	11.73	60	88	7.5	134	3	6	22.1	89	177	15	269	6	6	44.5
25W	12,500	11.36	60	88	7.7	134	3	6	22.1	89	118	10	179	4	6	29.7
30T	15,000	14.52	60	88	6.1	134	3	6	18.5	89	177	12	269	6	6	37.1
30W	15,000	14.34	60	88	6.1	134	3	6	18.5	89	118	8	179	4	6	24.7
35T	17,500	17.31	60	118	6.8	179	4	6	21.2	119	177	10	269	6	6	31.8
36W	18,000	18.67	60	118	6.3	179	4	6	20.6	119	177	9	269	6	6	30.9
37T	18,500	18.12	60	118	6.5	179	4	6	20.1	119	236	13	359	8	6	40.1
40W	20,000	20.57	60	118	5.7	179	4	6	18.6	119	177	9	269	6	6	27.8
42T	21,000	20.56	60	118	5.7	179	4	6	17.7	119	252	12	383	8	6	37.7
50W	25,000	25.83	60	148	5.7	225	5	6	18.6	149	177	7	269	6	6	22.3
51T	25,500	25.00	60	177	7.1	269	6	6	21.8	178	252	10	383	8	6	31.1
58T	29,000	28.43	60	177	6.2	269	6	6	19.2	178	252	9	383	8	6	27.3
61W	30,500	31.01	60	177	5.7	269	6	6	18.3	178	252	8	383	8	6	26.0
72W	36,000	35.86	60	207	5.8	315	7	6	18.1	208	252	7	383	8	6	22.0
85W	42,500	42.50	60	207	4.9	315	7	6	15.3	208	252	6	383	8	6	18.7
96W	48,000	47.99	60	236	4.9	359	8	6	15.5	237	252	5	383	8	6	16.5
110W	55,000	55.10	60	236	4.3	359	8	6	13.5	237	252	5	383	8	6	14.4



Electric Heater Data (cont)

39M UNIT SIZE	AIRFLOW	FACE AREA	LOW kW EH							HIGH kW EH						
			MIN kW	MAX kW	kW / SQ FT	MAX AMPS	SUB CIRCUITS AT MAX AMPS	CONTROL CIRCUITS AT MAX kW (SEE NOTE 1)	TEMP RISE AT 100% AIRFLOW	MIN kW	MAX kW	kW / SQ FT	MAX AMPS	SUB CIRCUITS AT MAX AMPS	CONTROL CIRCUITS AT MAX kW (SEE NOTE 1)	TEMP RISE AT 100% AIRFLOW
480V, LFA, Open Elements, Standard Controls without Disconnect																
03W	1,500	2.66	5	35	13.1	42	1	3	73.4	—	—	—	—	—	—	—
06W	3,000	4.90	10	39	8.0	47	1	3	40.9	40	60	12	72	2	3	62.9
07T	3,500	7.13	10	39	5.5	47	1	3	35.1	40	70	10	84	2	6	62.9
08W	4,000	7.03	20	79	11.2	95	2	6	62.1	80	80	11	96	3	6	62.9
09T	4,500	7.61	20	79	10.4	95	2	6	55.2	80	90	12	108	3	6	62.9
10W	5,000	9.54	20	79	8.3	95	2	6	49.7	80	100	10	120	3	6	62.9
11T	5,500	10.26	20	79	7.7	95	2	6	45.2	80	110	11	132	3	6	62.9
12T	6,000	11.38	20	79	6.9	95	2	6	41.4	80	120	11	145	4	6	62.9
12W	6,000	11.95	20	119	10.0	143	3	6	62.4	120	130	11	157	4	6	68.2
14W	7,000	13.15	30	119	9.0	143	3	6	53.5	120	150	11	181	4	6	67.4
16T	8,000	14.60	30	119	8.2	143	3	6	46.8	120	160	11	193	5	6	62.9
17W	8,500	16.12	30	119	7.4	143	3	6	44.0	120	175	11	211	5	6	64.8
18T	9,000	16.67	30	119	7.1	143	3	6	41.6	120	175	11	211	5	6	61.2
21W	10,500	20.39	40	119	5.8	143	3	6	35.7	120	220	11	265	6	6	65.9
22T	11,000	21.18	40	119	5.6	143	3	6	34.0	120	230	11	277	6	6	65.8
25T	12,500	23.45	40	119	5.1	143	3	6	29.9	120	250	11	301	7	6	62.9
25W	12,500	22.71	40	119	5.2	143	3	6	29.9	120	250	11	301	7	6	62.9
30T	15,000	29.05	40	119	4.1	143	3	6	25.0	120	275	9	331	7	6	57.7
30W	15,000	28.68	40	119	4.1	143	3	6	25.0	120	275	10	331	7	6	57.7
35T	17,500	34.61	60	239	6.9	288	6	6	43.0	240	350	10	421	9	6	62.9
36W	18,000	37.33	60	239	6.4	288	6	6	41.8	240	350	9	421	9	6	61.2
37T	18,500	36.24	60	239	6.6	288	6	6	40.6	240	360	10	434	10	6	61.2
40W	20,000	41.14	60	239	5.8	288	6	6	37.6	240	400	10	482	11	6	62.9
42T	21,000	41.12	60	239	5.8	288	6	6	35.8	240	400	10	482	11	6	59.9
50W	25,000	51.65	60	252	4.9	303	7	6	31.7	253	404	8	487	11	6	50.8
51T	25,500	50.01	60	252	5.0	303	7	6	31.1	253	404	8	487	11	6	49.8
58T	29,000	56.87	60	319	5.6	384	9	6	34.6	320	404	7	487	11	6	43.8
61W	30,500	62.01	60	319	5.1	384	9	6	32.9	320	404	7	487	11	6	41.7
72W	36,000	71.71	60	359	5.0	432	10	6	31.4	360	404	6	487	11	6	35.3
85W	42,500	85.01	60	359	4.2	432	10	6	26.6	360	404	5	487	11	6	29.9
96W	48,000	95.98	60	404	4.2	487	11	6	26.5	—	—	—	—	—	—	—
110W	55,000	110.20	60	404	3.7	487	11	6	23.1	—	—	—	—	—	—	—
480V, LFA, Sheathed Elements, Standard Controls without Disconnect																
03W	1,500	2.32	5	35	15.1	42	1	3	73.4	—	—	—	—	—	—	—
06W	3,000	4.55	10	39	8.6	47	1	3	40.9	40	60	13	72	2	3	62.9
07T	3,500	6.47	10	39	6.0	47	1	3	35.1	40	70	11	84	2	6	62.9
08W	4,000	6.65	20	79	11.9	95	2	6	62.1	80	80	12	96	3	6	62.9
09T	4,500	6.99	20	79	11.3	95	2	6	55.2	80	90	13	108	3	6	62.9
10W	5,000	9.15	20	79	8.6	95	2	6	49.7	80	100	11	120	3	6	62.9
11T	5,500	9.52	20	79	8.3	95	2	6	45.2	80	110	12	132	3	6	62.9
12T	6,000	10.64	20	79	7.4	95	2	6	41.4	80	120	11	145	4	6	62.9
12W	6,000	11.46	20	119	10.4	143	3	6	62.4	120	130	11	157	4	6	68.2
14W	7,000	12.67	30	119	9.4	143	3	6	53.5	120	150	12	181	4	6	67.4
16T	8,000	13.73	30	119	8.7	143	3	6	46.8	120	160	12	193	5	6	62.9
17W	8,500	15.60	30	119	7.6	143	3	6	44.0	120	175	11	211	5	6	64.8
18T	9,000	15.75	30	119	7.6	143	3	6	41.6	120	175	11	211	5	6	61.2
21W	10,500	19.73	40	119	6.0	143	3	6	35.7	120	220	11	265	6	6	65.9
22T	11,000	20.18	40	119	5.9	143	3	6	34.0	120	230	11	277	6	6	65.8
25T	12,500	22.39	40	119	5.3	143	3	6	29.9	120	250	11	301	7	6	62.9
25W	12,500	22.05	40	119	5.4	143	3	6	29.9	120	250	11	301	7	6	62.9
30T	15,000	27.98	40	119	4.3	143	3	6	25.0	120	275	10	331	7	6	57.7
30W	15,000	28.02	40	119	4.2	143	3	6	25.0	120	275	10	331	7	6	57.7
35T	17,500	33.51	60	239	7.1	288	6	6	43.0	240	350	10	421	9	6	62.9
36W	18,000	36.51	60	239	6.5	288	6	6	41.8	240	350	10	421	9	6	61.2
37T	18,500	34.91	60	239	6.8	288	6	6	40.6	240	360	10	434	10	6	61.2
40W	20,000	40.24	60	239	5.9	288	6	6	37.6	240	400	10	482	11	6	62.9
42T	21,000	39.81	60	239	6.0	288	6	6	35.8	240	400	10	482	11	6	59.9
50W	25,000	50.61	60	252	5.0	303	7	6	31.7	253	404	8	487	11	6	50.8
51T	25,500	48.69	60	252	5.2	303	7	6	31.1	253	404	8	487	11	6	49.8
58T	29,000	55.37	60	319	5.8	384	9	6	34.6	320	404	7	487	11	6	43.8
61W	30,500	60.77	60	319	5.2	384	9	6	32.9	320	404	7	487	11	6	41.7
72W	36,000	70.32	60	395	5.6	476	10	6	34.5	396	475	7	572	12	6	41.5
85W	42,500	83.61	60	395	4.7	476	10	6	29.2	396	475	6	572	12	6	35.2
96W	48,000	94.40	60	476	5.0	573	12	6	31.2	476	595	6	717	15	6	39.0
110W	55,000	108.62	60	476	4.4	573	12	6	27.2	476	595	5	717	15	6	34.0

Electric Heater Data (cont)

39M UNIT SIZE	AIRFLOW	FACE AREA	LOW kW EH							HIGH kW EH						
			MIN kW	MAX kW	kW / SQ FT	MAX AMPS	SUB CIRCUITS AT MAX AMPS	CONTROL CIRCUITS AT MAX kW (SEE NOTE 1)	TEMP RISE AT 100% AIRFLOW	MIN kW	MAX kW	kW / SQ FT	MAX AMPS	SUB CIRCUITS AT MAX AMPS	CONTROL CIRCUITS AT MAX kW (SEE NOTE 1)	TEMP RISE AT 100% AIRFLOW
480V, ERV, Sheathed Elements, Standard Controls without Disconnect																
03W	750	1.25	1	8	6.4	10	1	3	33.6	—	—	—	—	—	—	—
06W	1,500	2.46	2	15	6.1	18	1	3	31.5	—	—	—	—	—	—	—
07T	1,750	—	—	—	—	—	—	—	—	—	—	—	—	—	—	—
08W	2,000	3.57	5	20	5.6	24	1	3	31.5	—	—	—	—	—	—	—
09T	2,250	—	—	—	—	—	—	—	—	—	—	—	—	—	—	—
10W	2,500	4.91	5	25	5.1	30	1	3	31.5	—	—	—	—	—	—	—
11T	2,750	—	—	—	—	—	—	—	—	—	—	—	—	—	—	—
12T	3,000	—	—	—	—	—	—	—	—	—	—	—	—	—	—	—
12W	3,000	6.23	5	30	4.8	36	1	3	31.5	—	—	—	—	—	—	—
14W	3,500	6.88	5	35	5.1	42	1	3	31.5	—	—	—	—	—	—	—
16T	4,000	—	—	—	—	—	—	—	—	—	—	—	—	—	—	—
17W	4,250	8.21	5	45	5.5	54	2	3	33.3	—	—	—	—	—	—	—
18T	4,500	—	—	—	—	—	—	—	—	—	—	—	—	—	—	—
21W	5,250	10.28	10	50	4.9	60	2	3	30.0	—	—	—	—	—	—	—
22T	5,500	—	—	—	—	—	—	—	—	—	—	—	—	—	—	—
25T	6,250	—	—	—	—	—	—	—	—	—	—	—	—	—	—	—
25W	6,250	11.49	10	60	5.2	72	2	3	30.2	—	—	—	—	—	—	—
30T	7,500	—	—	—	—	—	—	—	—	—	—	—	—	—	—	—
30W	7,500	14.60	10	70	4.8	84	2	6	29.4	—	—	—	—	—	—	—
35T	8,750	—	—	—	—	—	—	—	—	—	—	—	—	—	—	—
36W	9,000	22.72	15	90	4.0	108	3	6	31.5	—	—	—	—	—	—	—
37T	9,250	—	—	—	—	—	—	—	—	—	—	—	—	—	—	—
40W	10,000	24.58	15	100	4.1	120	3	6	31.5	—	—	—	—	—	—	—
42T	10,500	—	—	—	—	—	—	—	—	—	—	—	—	—	—	—
50W	12,500	31.18	15	125	4.0	151	4	6	31.5	—	—	—	—	—	—	—
51T	12,750	—	—	—	—	—	—	—	—	—	—	—	—	—	—	—
58T	14,500	—	—	—	—	—	—	—	—	—	—	—	—	—	—	—
61W	15,250	32.53	15	150	4.6	181	4	6	30.9	—	—	—	—	—	—	—
72W	18,000	—	—	—	—	—	—	—	—	—	—	—	—	—	—	—
85W	21,250	—	—	—	—	—	—	—	—	—	—	—	—	—	—	—
96W	24,000	—	—	—	—	—	—	—	—	—	—	—	—	—	—	—
110W	27,500	—	—	—	—	—	—	—	—	—	—	—	—	—	—	—
480V, LFA, Open Elements, Standard Controls with Full SCR																
03W	1,500	2.66	1	35	13.1	42	1	3	73.4	—	—	—	—	—	—	—
06W	3,000	4.90	1	37	7.6	45	1	3	38.8	38	60	12	72	2	3	62.9
07T	3,500	7.13	2	37	5.2	45	1	3	33.3	38	70	10	84	2	6	62.9
08W	4,000	7.03	1	74	10.5	89	2	6	58.2	—	—	—	—	—	—	—
09T	4,500	7.61	2	74	9.7	89	2	6	51.7	—	—	—	—	—	—	—
10W	5,000	9.54	2	74	7.8	89	2	6	46.6	—	—	—	—	—	—	—
11T	5,500	10.26	2	74	7.2	89	2	6	42.3	—	—	—	—	—	—	—
12T	6,000	11.38	2	74	6.5	89	2	6	38.8	—	—	—	—	—	—	—
12W	6,000	11.95	2	74	6.2	89	2	6	38.8	—	—	—	—	—	—	—
14W	7,000	13.15	2	74	5.6	89	2	6	33.3	—	—	—	—	—	—	—
16T	8,000	14.60	2	74	5.1	89	2	6	29.1	—	—	—	—	—	—	—
17W	8,500	16.12	2	74	4.6	89	2	6	27.4	—	—	—	—	—	—	—
18T	9,000	16.67	2	74	4.4	89	2	6	25.9	—	—	—	—	—	—	—
21W	10,500	20.39	3	74	3.6	89	2	6	22.2	—	—	—	—	—	—	—
22T	11,000	21.18	3	74	3.5	89	2	6	21.2	—	—	—	—	—	—	—
25T	12,500	23.45	4	74	3.2	89	2	6	18.6	—	—	—	—	—	—	—
25W	12,500	22.71	4	74	3.3	89	2	6	18.6	—	—	—	—	—	—	—
30T	15,000	29.05	4	74	2.5	89	2	6	15.5	—	—	—	—	—	—	—
30W	15,000	28.68	4	74	2.6	89	2	6	15.5	—	—	—	—	—	—	—
35T	17,500	34.61	5	74	2.1	89	2	6	13.3	—	—	—	—	—	—	—
36W	18,000	37.33	5	74	2.0	89	2	6	12.9	—	—	—	—	—	—	—
37T	18,500	36.24	5	74	2.0	89	2	6	12.6	—	—	—	—	—	—	—
40W	20,000	41.14	5	74	1.8	89	2	6	11.6	—	—	—	—	—	—	—
42T	21,000	41.12	5	74	1.8	89	2	6	11.1	—	—	—	—	—	—	—
50W	25,000	51.65	7	74	1.4	89	2	6	9.3	—	—	—	—	—	—	—
51T	25,500	50.01	7	74	1.5	89	2	6	9.1	—	—	—	—	—	—	—
58T	29,000	56.87	7	74	1.3	89	2	6	8.0	—	—	—	—	—	—	—
61W	30,500	62.01	7	74	1.2	89	2	6	7.6	—	—	—	—	—	—	—
72W	36,000	71.71	7	74	1.0	89	2	6	6.5	—	—	—	—	—	—	—
85W	42,500	85.01	8	74	0.9	89	2	6	5.5	—	—	—	—	—	—	—
96W	48,000	95.98	10	74	0.8	89	2	6	4.8	—	—	—	—	—	—	—
110W	55,000	110.20	10	74	0.7	89	2	6	4.2	—	—	—	—	—	—	—



Electric Heater Data (cont)

39M UNIT SIZE	AIRFLOW	FACE AREA	LOW kW EH							HIGH kW EH						
			MIN kW	MAX kW	kW / SQ FT	MAX AMPS	SUB CIRCUITS AT MAX AMPS	CONTROL CIRCUITS AT MAX kW (SEE NOTE 1)	TEMP RISE AT 100% AIRFLOW	MIN kW	MAX kW	kW / SQ FT	MAX AMPS	SUB CIRCUITS AT MAX AMPS	CONTROL CIRCUITS AT MAX kW (SEE NOTE 1)	TEMP RISE AT 100% AIRFLOW
480V, LFA, Open Elements, Standard Controls with Vernier SCR																
03W	1,500	2.66	—	—	—	—	—	—	—	—	—	—	—	—	—	—
06W	3,000	4.90	—	—	—	—	—	—	—	—	—	—	—	—	—	—
07T	3,500	7.13	—	—	—	—	—	—	—	71	80	11	96	3	6	71.9
08W	4,000	7.03	—	—	—	—	—	—	—	75	80	11	96	3	6	62.9
09T	4,500	7.61	—	—	—	—	—	—	—	75	100	13	120	3	6	69.9
10W	5,000	9.54	—	—	—	—	—	—	—	75	100	10	120	3	6	62.9
11T	5,500	10.26	—	—	—	—	—	—	—	75	130	13	157	4	6	74.4
12T	6,000	11.38	—	—	—	—	—	—	—	75	130	11	157	4	6	68.2
12W	6,000	11.95	—	—	—	—	—	—	—	75	130	11	157	4	6	68.2
14W	7,000	13.15	—	—	—	—	—	—	—	75	150	11	181	4	6	67.4
16T	8,000	14.60	—	—	—	—	—	—	—	75	150	10	181	4	6	59.0
17W	8,500	16.12	—	—	—	—	—	—	—	75	175	11	211	5	6	64.8
18T	9,000	16.67	—	—	—	—	—	—	—	75	175	11	211	5	6	61.2
21W	10,500	20.39	75	112	5.5	135	3	6	33.6	113	220	11	265	6	6	65.9
22T	11,000	21.18	75	112	5.3	135	3	6	32.0	113	220	10	265	6	6	62.9
25T	12,500	23.45	75	112	4.8	135	3	6	28.2	113	250	11	301	7	6	62.9
25W	12,500	22.71	75	112	4.9	135	3	6	28.2	113	250	11	301	7	6	62.9
30T	15,000	29.05	75	112	3.9	135	3	6	23.5	113	252	9	303	7	6	52.8
30W	15,000	28.68	75	112	3.9	135	3	6	23.5	113	252	9	303	7	6	52.8
35T	17,500	34.61	75	149	4.3	179	4	6	26.8	150	299	9	360	8	6	53.7
36W	18,000	37.33	75	149	4.0	179	4	6	26.0	150	299	8	360	8	6	52.3
37T	18,500	36.24	75	149	4.1	179	4	6	25.3	150	299	8	360	8	6	50.8
40W	20,000	41.14	75	149	3.6	179	4	6	23.4	150	336	8	405	9	6	52.8
42T	21,000	41.12	75	149	3.6	179	4	6	22.3	150	336	8	405	9	6	50.3
50W	25,000	51.65	75	187	3.6	225	5	6	23.5	188	404	8	487	11	6	50.8
51T	25,500	50.01	75	187	3.7	225	5	6	23.1	188	404	8	487	11	6	49.8
58T	29,000	56.87	75	224	3.9	270	6	6	24.3	225	404	7	487	11	6	43.8
61W	30,500	62.01	75	224	3.6	270	6	6	23.1	225	404	7	487	11	6	41.7
72W	36,000	71.71	75	261	3.6	314	7	6	22.8	262	404	6	487	11	6	35.3
85W	42,500	85.01	75	261	3.1	314	7	6	19.3	262	404	5	487	11	6	29.9
96W	48,000	95.98	75	299	3.1	360	8	6	19.6	300	404	4	487	11	6	26.5
110W	55,000	110.20	75	299	2.7	360	8	6	17.1	300	404	4	487	11	6	23.1
480V, VAV, Open Elements, Standard Controls without Disconnect																
03W	1,500	1.33	5	9	6.8	11	1	3	18.9	—	—	—	—	—	—	—
06W	3,000	2.45	3	16	6.5	19	1	3	16.8	—	—	—	—	—	—	—
07T	3,500	3.56	3	24	6.7	29	1	3	21.6	—	—	—	—	—	—	—
08W	4,000	3.52	3	23	6.5	28	1	3	18.1	—	—	—	—	—	—	—
09T	4,500	3.81	3	25	6.6	30	1	3	17.5	—	—	—	—	—	—	—
10W	5,000	4.77	3	32	6.7	39	1	3	20.1	—	—	—	—	—	—	—
11T	5,500	5.13	3	34	6.6	41	1	3	19.4	—	—	—	—	—	—	—
12T	6,000	5.69	3	38	6.7	46	1	3	19.9	—	—	—	—	—	—	—
12W	6,000	5.97	6	40	6.7	48	2	3	21.0	—	—	—	—	—	—	—
14W	7,000	6.58	6	44	6.7	53	2	3	19.8	—	—	—	—	—	—	—
16T	8,000	7.30	3	49	6.7	59	2	3	19.3	—	—	—	—	—	—	—
17W	8,500	8.06	3	54	6.7	65	2	3	20.0	—	—	—	—	—	—	—
18T	9,000	8.33	3	55	6.6	66	2	3	19.2	—	—	—	—	—	—	—
21W	10,500	10.20	3	68	6.7	82	2	6	20.4	—	—	—	—	—	—	—
22T	11,000	10.59	3	70	6.6	84	2	6	20.0	—	—	—	—	—	—	—
25T	12,500	11.73	3	78	6.7	94	2	6	19.6	—	—	—	—	—	—	—
25W	12,500	11.36	3	76	6.7	92	2	6	19.1	—	—	—	—	—	—	—
30T	15,000	14.52	3	97	6.7	117	3	6	20.3	—	—	—	—	—	—	—
30W	15,000	14.34	3	96	6.7	116	3	6	20.1	—	—	—	—	—	—	—
35T	17,500	17.31	3	115	6.6	138	3	6	20.7	—	—	—	—	—	—	—
36W	18,000	18.67	3	124	6.6	149	4	6	21.7	—	—	—	—	—	—	—
37T	18,500	18.12	6	120	6.6	145	4	6	20.4	—	—	—	—	—	—	—
40W	20,000	20.57	3	137	6.7	165	4	6	21.5	—	—	—	—	—	—	—
42T	21,000	20.56	6	137	6.7	165	4	6	20.5	—	—	—	—	—	—	—
50W	25,000	25.83	3	172	6.7	207	5	6	21.6	—	—	—	—	—	—	—
51T	25,500	25.00	6	166	6.6	200	5	6	20.5	—	—	—	—	—	—	—
58T	29,000	28.43	5	189	6.6	228	5	6	20.5	—	—	—	—	—	—	—
61W	30,500	31.01	6	206	6.6	248	6	6	21.2	—	—	—	—	—	—	—
72W	36,000	35.86	6	238	6.6	287	6	6	20.8	—	—	—	—	—	—	—
85W	42,500	42.50	6	283	6.7	341	8	6	20.9	—	—	—	—	—	—	—
96W	48,000	47.99	6	319	6.6	384	9	6	20.9	—	—	—	—	—	—	—
110W	55,000	55.10	6	366	6.6	441	10	6	20.9	—	—	—	—	—	—	—

Electric Heater Data (cont)

39M UNIT SIZE	AIRFLOW	FACE AREA	LOW kW EH							HIGH kW EH						
			MIN kW	MAX kW	kW / SQ FT	MAX AMPS	SUB CIRCUITS AT MAX AMPS	CONTROL CIRCUITS AT MAX kW (SEE NOTE 1)	TEMP RISE AT 100% AIRFLOW	MIN kW	MAX kW	kW / SQ FT	MAX AMPS	SUB CIRCUITS AT MAX AMPS	CONTROL CIRCUITS AT MAX kW (SEE NOTE 1)	TEMP RISE AT 100% AIRFLOW
480V, VAV, Open Elements, Standard Controls with Full SCR																
03W	1,500	1.33	1	19	14.3	23	1	3	39.8	—	—	—	—	—	—	—
06W	3,000	2.45	1	37	15.1	45	1	3	38.8	38	47	19	57	2	3	49.3
07T	3,500	3.56	1	37	10.4	45	1	3	33.3	38	70	20	84	2	6	62.9
08W	4,000	3.52	1	68	19.3	82	2	6	53.5	—	—	—	—	—	—	—
09T	4,500	3.81	1	74	19.4	89	2	6	51.7	—	—	—	—	—	—	—
10W	5,000	4.77	1	74	15.5	89	2	6	46.6	—	—	—	—	—	—	—
11T	5,500	5.13	1	74	14.4	89	2	6	42.3	—	—	—	—	—	—	—
12T	6,000	5.69	1	74	13.0	89	2	6	38.8	—	—	—	—	—	—	—
12W	6,000	5.97	2	74	12.4	89	2	6	38.8	—	—	—	—	—	—	—
14W	7,000	6.58	2	74	11.3	89	2	6	33.3	—	—	—	—	—	—	—
16T	8,000	7.30	1	74	10.1	89	2	6	29.1	—	—	—	—	—	—	—
17W	8,500	8.06	2	74	9.2	89	2	6	27.4	—	—	—	—	—	—	—
18T	9,000	8.33	1	74	8.9	89	2	6	25.9	—	—	—	—	—	—	—
21W	10,500	10.20	2	74	7.3	89	2	6	22.2	—	—	—	—	—	—	—
22T	11,000	10.59	2	74	7.0	89	2	6	21.2	—	—	—	—	—	—	—
25T	12,500	11.73	2	74	6.3	89	2	6	18.6	—	—	—	—	—	—	—
25W	12,500	11.36	2	74	6.5	89	2	6	18.6	—	—	—	—	—	—	—
30T	15,000	14.52	2	74	5.1	89	2	6	15.5	—	—	—	—	—	—	—
30W	15,000	14.34	2	74	5.2	89	2	6	15.5	—	—	—	—	—	—	—
35T	17,500	17.31	2	74	4.3	89	2	6	13.3	—	—	—	—	—	—	—
36W	18,000	18.67	3	74	4.0	89	2	6	12.9	—	—	—	—	—	—	—
37T	18,500	18.12	3	74	4.1	89	2	6	12.6	—	—	—	—	—	—	—
40W	20,000	20.57	3	74	3.6	89	2	6	11.6	—	—	—	—	—	—	—
42T	21,000	20.56	3	74	3.6	89	2	6	11.1	—	—	—	—	—	—	—
50W	25,000	25.83	3	74	2.9	89	2	6	9.3	—	—	—	—	—	—	—
51T	25,500	25.00	4	74	3.0	89	2	6	9.1	—	—	—	—	—	—	—
58T	29,000	28.43	4	74	2.6	89	2	6	8.0	—	—	—	—	—	—	—
61W	30,500	31.01	4	74	2.4	89	2	6	7.6	—	—	—	—	—	—	—
72W	36,000	35.86	5	74	2.1	89	2	6	6.5	—	—	—	—	—	—	—
85W	42,500	42.50	5	74	1.7	89	2	6	5.5	—	—	—	—	—	—	—
96W	48,000	47.99	5	74	1.5	89	2	6	4.8	—	—	—	—	—	—	—
110W	55,000	55.10	5	74	1.3	89	2	6	4.2	—	—	—	—	—	—	—
480V, VAV, Open Elements, Standard Controls with Vernier SCR																
11T	5,500	5.13	75	130	25.3	157	4	6	74.4	—	—	—	—	—	—	—
12T	6,000	5.69	75	130	22.8	157	4	6	68.2	—	—	—	—	—	—	—
12W	6,000	5.97	75	130	21.8	157	4	6	68.2	—	—	—	—	—	—	—
14W	7,000	6.58	75	149	22.7	179	4	6	67.0	—	—	—	—	—	—	—
16T	8,000	7.30	75	150	20.6	181	4	6	59.0	—	—	—	—	—	—	—
17W	8,500	8.06	75	149	18.5	179	4	6	55.1	—	—	—	—	—	—	—
18T	9,000	8.33	75	170	20.4	205	5	6	59.4	—	—	—	—	—	—	—
21W	10,500	10.20	75	112	11.0	135	3	6	33.6	113	149	15	179	4	6	44.6
22T	11,000	10.59	75	112	10.6	135	3	6	32.0	113	220	21	265	6	6	62.9
25T	12,500	11.73	75	112	9.6	135	3	6	28.2	113	224	19	270	6	6	56.4
25W	12,500	11.36	75	112	9.9	135	3	6	28.2	113	149	13	179	4	6	37.5
30T	15,000	14.52	75	112	7.7	135	3	6	23.5	113	224	15	270	6	6	47.0
30W	15,000	14.34	75	112	7.8	135	3	6	23.5	113	149	10	179	4	6	31.2
35T	17,500	17.31	75	149	8.6	179	4	6	26.8	150	224	13	270	6	6	40.3
36W	18,000	18.67	75	149	8.0	179	4	6	26.0	150	224	12	270	6	6	39.1
37T	18,500	18.12	75	149	8.2	179	4	6	25.3	150	299	17	360	8	6	50.8
40W	20,000	20.57	75	149	7.2	179	4	6	23.4	150	224	11	270	6	6	35.2
42T	21,000	20.56	75	149	7.2	179	4	6	22.3	150	300	15	361	8	6	44.9
50W	25,000	25.83	75	187	7.2	225	5	6	23.5	188	224	9	270	6	6	28.2
51T	25,500	25.00	75	187	7.5	225	5	6	23.1	188	374	15	450	10	6	46.1
58T	29,000	28.43	75	224	7.9	270	6	6	24.3	225	374	13	450	10	6	40.6
61W	30,500	31.01	75	224	7.2	270	6	6	23.1	225	374	12	450	10	6	38.6
72W	36,000	35.86	75	261	7.3	314	7	6	22.8	262	374	10	450	10	6	32.7
85W	42,500	42.50	75	261	6.1	314	7	6	19.3	262	374	9	450	10	6	27.7
96W	48,000	47.99	75	299	6.2	360	8	6	19.6	300	374	8	450	10	6	24.5
110W	55,000	55.10	75	299	5.4	360	8	6	17.1	300	374	7	450	10	6	21.4



Electric Heater Data (cont)

39M UNIT SIZE	AIRFLOW	FACE AREA	LOW kW EH							HIGH kW EH						
			MIN kW	MAX kW	kW / SQ FT	MAX AMPS	SUB CIRCUITS AT MAX AMPS	CONTROL CIRCUITS AT MAX kW (SEE NOTE 1)	TEMP RISE AT 100% AIRFLOW	MIN kW	MAX kW	kW / SQ FT	MAX AMPS	SUB CIRCUITS AT MAX AMPS	CONTROL CIRCUITS AT MAX kW (SEE NOTE 1)	TEMP RISE AT 100% AIRFLOW
600V, LFA, Open Elements, Standard Controls without Disconnect																
03W	1,500	2.66	5	35	13.1	34	1	3	73.4	—	—	—	—	—	—	—
06W	3,000	4.90	10	49	10.0	47	1	3	51.4	50	60	12	58	2	3	62.9
07T	3,500	7.13	10	49	6.9	47	1	3	44.0	50	70	10	67	2	6	62.9
08W	4,000	7.03	20	80	11.4	77	2	6	62.9	—	—	—	—	—	—	—
09T	4,500	7.61	20	90	11.8	87	2	6	62.9	—	—	—	—	—	—	—
10W	5,000	9.54	20	99	10.4	95	2	6	62.3	100	100	10	96	3	6	62.9
11T	5,500	10.26	20	110	10.7	106	3	6	62.9	—	—	—	—	—	—	—
12T	6,000	11.38	20	120	10.5	116	3	6	62.9	—	—	—	—	—	—	—
12W	6,000	11.95	20	130	10.9	125	3	6	68.2	—	—	—	—	—	—	—
14W	7,000	13.15	30	149	11.3	144	3	6	67.0	150	150	11	145	4	6	67.4
16T	8,000	14.60	30	149	10.2	144	3	6	58.6	150	160	11	154	4	6	62.9
17W	8,500	16.12	30	149	9.2	144	3	6	55.1	150	175	11	169	4	6	64.8
18T	9,000	16.67	30	149	8.9	144	3	6	52.1	150	175	11	169	4	6	61.2
21W	10,500	20.39	40	149	7.3	144	3	6	44.6	150	220	11	212	5	6	65.9
22T	11,000	21.18	40	149	7.0	144	3	6	42.6	150	230	11	222	5	6	65.8
25T	12,500	23.45	40	149	6.4	144	3	6	37.5	150	250	11	241	6	6	62.9
25W	12,500	22.71	40	149	6.6	144	3	6	37.5	150	250	11	241	6	6	62.9
30T	15,000	29.05	40	149	5.1	144	3	6	31.2	150	275	9	265	6	6	57.7
30W	15,000	28.68	40	149	5.2	144	3	6	31.2	150	275	10	265	6	6	57.7
35T	17,500	34.61	60	299	8.6	288	7	6	53.7	300	350	10	337	8	6	62.9
36W	18,000	37.33	60	299	8.0	288	7	6	52.3	300	350	9	337	8	6	61.2
37T	18,500	36.24	60	299	8.3	288	7	6	50.8	300	360	10	347	8	6	61.2
40W	20,000	41.14	60	299	7.3	288	7	6	47.0	300	400	10	385	9	6	62.9
42T	21,000	41.12	60	299	7.3	288	7	6	44.8	300	400	10	385	9	6	59.9
50W	25,000	51.65	60	315	6.1	303	7	6	39.6	316	500	10	482	11	6	62.9
51T	25,500	50.01	60	315	6.3	303	7	6	38.9	316	500	10	482	11	6	61.7
58T	29,000	56.87	60	399	7.0	384	9	6	43.3	400	505	9	487	11	6	54.8
61W	30,500	62.01	60	399	6.4	384	9	6	41.2	400	505	8	487	11	6	52.1
72W	36,000	71.71	60	448	6.2	432	9	6	39.1	449	505	7	487	11	6	44.1
85W	42,500	85.01	60	448	5.3	432	9	6	33.2	449	505	6	487	11	6	37.4
96W	48,000	95.98	60	505	5.3	487	11	6	33.1	—	—	—	—	—	—	—
110W	55,000	110.20	60	505	4.6	487	11	6	28.9	—	—	—	—	—	—	—
600V, LFA, Sheathed Elements, Standard Controls without Disconnect																
03W	1,500	2.32	5	35	15.1	34	1	3	73.4	—	—	—	—	—	—	—
06W	3,000	4.55	10	49	10.8	47	1	3	51.4	50	60	13	58	2	3	62.9
07T	3,500	6.47	10	49	7.6	47	1	3	44.0	50	70	11	67	2	6	62.9
08W	4,000	6.65	20	80	12.0	77	2	6	62.9	—	—	—	—	—	—	—
09T	4,500	6.99	20	90	12.9	87	2	6	62.9	—	—	—	—	—	—	—
10W	5,000	9.15	20	99	10.8	95	2	6	62.3	100	100	11	96	3	6	62.9
11T	5,500	9.52	20	110	11.6	106	3	6	62.9	—	—	—	—	—	—	—
12T	6,000	10.64	20	120	11.3	116	3	6	62.9	—	—	—	—	—	—	—
12W	6,000	11.46	20	130	11.3	125	3	6	68.2	—	—	—	—	—	—	—
14W	7,000	12.67	30	149	11.8	144	3	6	67.0	150	150	12	145	4	6	67.4
16T	8,000	13.73	30	149	10.9	144	3	6	58.6	150	160	12	154	4	6	62.9
17W	8,500	15.60	30	149	9.6	144	3	6	55.1	150	175	11	169	4	6	64.8
18T	9,000	15.75	30	149	9.5	144	3	6	52.1	150	175	11	169	4	6	61.2
21W	10,500	19.73	40	149	7.6	144	3	6	44.6	150	220	11	212	5	6	65.9
22T	11,000	20.18	40	149	7.4	144	3	6	42.6	150	230	11	222	5	6	65.8
25T	12,500	22.39	40	149	6.7	144	3	6	37.5	150	250	11	241	6	6	62.9
25W	12,500	22.05	40	149	6.8	144	3	6	37.5	150	250	11	241	6	6	62.9
30T	15,000	27.98	40	149	5.3	144	3	6	31.2	150	275	10	265	6	6	57.7
30W	15,000	28.02	40	149	5.3	144	3	6	31.2	150	275	10	265	6	6	57.7
35T	17,500	33.51	60	299	8.9	288	7	6	53.7	300	350	10	337	8	6	62.9
36W	18,000	36.51	60	299	8.2	288	7	6	52.3	300	350	10	337	8	6	61.2
37T	18,500	34.91	60	299	8.6	288	7	6	50.8	300	360	10	347	8	6	61.2
40W	20,000	40.24	60	299	7.4	288	7	6	47.0	300	400	10	385	9	6	62.9
42T	21,000	39.81	60	299	7.5	288	7	6	44.8	300	400	10	385	9	6	59.9
50W	25,000	50.61	60	315	6.2	303	7	6	39.6	316	500	10	482	11	6	62.9
51T	25,500	48.69	60	315	6.5	303	7	6	38.9	316	500	10	482	11	6	61.7
58T	29,000	55.37	60	399	7.2	384	9	6	43.3	400	505	9	487	11	6	54.8
61W	30,500	60.77	60	399	6.6	384	9	6	41.2	400	505	8	487	11	6	52.1
72W	36,000	70.32	60	490	7.0	472	10	6	42.8	491	588	8	566	12	6	51.4
85W	42,500	83.61	60	490	5.9	472	10	6	36.3	491	588	7	566	12	6	43.5
96W	48,000	94.40	60	588	6.2	566	12	6	38.5	589	735	8	708	15	6	48.2
110W	55,000	108.62	60	588	5.4	566	12	6	33.6	589	735	7	708	15	6	42.0

Electric Heater Data (cont)

39M UNIT SIZE	AIRFLOW	FACE AREA	LOW kW EH							HIGH kW EH						
			MIN kW	MAX kW	kW / SQ FT	MAX AMPS	SUB CIRCUITS AT MAX AMPS	CONTROL CIRCUITS AT MAX kW (SEE NOTE 1)	TEMP RISE AT 100% AIRFLOW	MIN kW	MAX kW	kW / SQ FT	MAX AMPS	SUB CIRCUITS AT MAX AMPS	CONTROL CIRCUITS AT MAX kW (SEE NOTE 1)	TEMP RISE AT 100% AIRFLOW
600V, ERV, Sheathed Elements, Standard Controls without Disconnect																
03W	750	1.25	1	8	6.4	8	1	3	33.6	—	—	—	—	—	—	—
06W	1,500	2.46	2	15	6.1	14	1	3	31.5	—	—	—	—	—	—	—
07T	1,750	—	—	—	—	—	—	—	—	—	—	—	—	—	—	—
08W	2,000	3.57	5	20	5.6	19	1	3	31.5	—	—	—	—	—	—	—
09T	2,250	—	—	—	—	—	—	—	—	—	—	—	—	—	—	—
10W	2,500	4.91	5	25	5.1	24	1	3	31.5	—	—	—	—	—	—	—
11T	2,750	—	—	—	—	—	—	—	—	—	—	—	—	—	—	—
12T	3,000	—	—	—	—	—	—	—	—	—	—	—	—	—	—	—
12W	3,000	6.23	5	30	4.8	29	1	3	31.5	—	—	—	—	—	—	—
14W	3,500	6.88	5	35	5.1	34	1	3	31.5	—	—	—	—	—	—	—
16T	4,000	—	—	—	—	—	—	—	—	—	—	—	—	—	—	—
17W	4,250	8.21	5	45	5.5	43	1	3	33.3	—	—	—	—	—	—	—
18T	4,500	—	—	—	—	—	—	—	—	—	—	—	—	—	—	—
21W	5,250	10.28	10	50	4.9	48	2	3	30.0	—	—	—	—	—	—	—
22T	5,500	—	—	—	—	—	—	—	—	—	—	—	—	—	—	—
25T	6,250	—	—	—	—	—	—	—	—	—	—	—	—	—	—	—
25W	6,250	11.49	10	60	5.2	58	2	3	30.2	—	—	—	—	—	—	—
30T	7,500	—	—	—	—	—	—	—	—	—	—	—	—	—	—	—
30W	7,500	14.60	10	70	4.8	67	2	6	29.4	—	—	—	—	—	—	—
35T	8,750	—	—	—	—	—	—	—	—	—	—	—	—	—	—	—
36W	9,000	22.72	15	90	4.0	87	2	6	31.5	—	—	—	—	—	—	—
37T	9,250	—	—	—	—	—	—	—	—	—	—	—	—	—	—	—
40W	10,000	24.58	15	100	4.1	96	3	6	31.5	—	—	—	—	—	—	—
42T	10,500	—	—	—	—	—	—	—	—	—	—	—	—	—	—	—
50W	12,500	31.18	15	125	4.0	120	3	6	31.5	—	—	—	—	—	—	—
51T	12,750	—	—	—	—	—	—	—	—	—	—	—	—	—	—	—
58T	14,500	—	—	—	—	—	—	—	—	—	—	—	—	—	—	—
61W	15,250	32.53	15	150	4.6	145	4	6	30.9	—	—	—	—	—	—	—
72W	18,000	—	—	—	—	—	—	—	—	—	—	—	—	—	—	—
85W	21,250	—	—	—	—	—	—	—	—	—	—	—	—	—	—	—
96W	24,000	—	—	—	—	—	—	—	—	—	—	—	—	—	—	—
110W	27,500	—	—	—	—	—	—	—	—	—	—	—	—	—	—	—
600V, LFA, Open Elements, Standard Controls with Full SCR																
03W	1,500	2.66	2	35	13.1	34	1	3	73.4	—	—	—	—	—	—	—
06W	3,000	4.90	2	46	9.4	44	1	3	48.2	47	60	12	58	2	3	62.9
07T	3,500	7.13	3	46	6.5	44	1	3	41.3	47	70	10	67	2	6	62.9
08W	4,000	7.03	2	80	11.4	77	2	6	62.9	—	—	—	—	—	—	—
09T	4,500	7.61	3	93	12.2	90	2	6	65.0	—	—	—	—	—	—	—
10W	5,000	9.54	2	93	9.7	90	2	6	58.5	—	—	—	—	—	—	—
11T	5,500	10.26	3	93	9.1	90	2	6	53.2	—	—	—	—	—	—	—
12T	6,000	11.38	3	93	8.2	90	2	6	48.8	—	—	—	—	—	—	—
12W	6,000	11.95	2	93	7.8	90	2	6	48.8	—	—	—	—	—	—	—
14W	7,000	13.15	2	93	7.1	90	2	6	41.8	—	—	—	—	—	—	—
16T	8,000	14.60	2	93	6.4	90	2	6	36.6	—	—	—	—	—	—	—
17W	8,500	16.12	2	93	5.8	90	2	6	34.4	—	—	—	—	—	—	—
18T	9,000	16.67	2	93	5.6	90	2	6	32.5	—	—	—	—	—	—	—
21W	10,500	20.39	3	93	4.6	90	2	6	27.9	—	—	—	—	—	—	—
22T	11,000	21.18	3	93	4.4	90	2	6	26.6	—	—	—	—	—	—	—
25T	12,500	23.45	4	93	4.0	90	2	6	23.4	—	—	—	—	—	—	—
25W	12,500	22.71	4	93	4.1	90	2	6	23.4	—	—	—	—	—	—	—
30T	15,000	29.05	4	93	3.2	90	2	6	19.5	—	—	—	—	—	—	—
30W	15,000	28.68	4	93	3.2	90	2	6	19.5	—	—	—	—	—	—	—
35T	17,500	34.61	5	93	2.7	90	2	6	16.7	—	—	—	—	—	—	—
36W	18,000	37.33	5	93	2.5	90	2	6	16.3	—	—	—	—	—	—	—
37T	18,500	36.24	5	93	2.6	90	2	6	15.8	—	—	—	—	—	—	—
40W	20,000	41.14	5	93	2.3	90	2	6	14.6	—	—	—	—	—	—	—
42T	21,000	41.12	5	93	2.3	90	2	6	13.9	—	—	—	—	—	—	—
50W	25,000	51.65	7	93	1.8	90	2	6	11.7	—	—	—	—	—	—	—
51T	25,500	50.01	7	93	1.9	90	2	6	11.5	—	—	—	—	—	—	—
58T	29,000	56.87	7	93	1.6	90	2	6	10.1	—	—	—	—	—	—	—
61W	30,500	62.01	7	93	1.5	90	2	6	9.6	—	—	—	—	—	—	—
72W	36,000	71.71	7	93	1.3	90	2	6	8.1	—	—	—	—	—	—	—
85W	42,500	85.01	8	93	1.1	90	2	6	6.9	—	—	—	—	—	—	—
96W	48,000	95.98	11	93	1.0	90	2	6	6.1	—	—	—	—	—	—	—
110W	55,000	110.20	12	93	0.8	90	2	6	5.3	—	—	—	—	—	—	—



Electric Heater Data (cont)

39M UNIT SIZE	AIRFLOW	FACE AREA	LOW kW EH							HIGH kW EH						
			MIN kW	MAX kW	kW / SQ FT	MAX AMPS	SUB CIRCUITS AT MAX AMPS	CONTROL CIRCUITS AT MAX kW (SEE NOTE 1)	TEMP RISE AT 100% AIRFLOW	MIN kW	MAX kW	kW / SQ FT	MAX AMPS	SUB CIRCUITS AT MAX AMPS	CONTROL CIRCUITS AT MAX kW (SEE NOTE 1)	TEMP RISE AT 100% AIRFLOW
600V, LFA, Open Elements, Standard Controls with Vernier SCR																
03W	1,500	2.66	—	—	—	—	—	—	—	—	—	—	—	—	—	—
06W	3,000	4.90	—	—	—	—	—	—	—	—	—	—	—	—	—	—
07T	3,500	7.13	—	—	—	—	—	—	—	—	—	—	—	—	—	—
08W	4,000	7.03	—	—	—	—	—	—	—	—	—	—	—	—	—	—
09T	4,500	7.61	—	—	—	—	—	—	—	94	100	13	96	3	6	69.9
10W	5,000	9.54	—	—	—	—	—	—	—	94	100	10	96	3	6	62.9
11T	5,500	10.26	—	—	—	—	—	—	—	94	130	13	125	3	6	74.4
12T	6,000	11.38	—	—	—	—	—	—	—	94	130	11	125	3	6	68.2
12W	6,000	11.95	—	—	—	—	—	—	—	94	130	11	125	3	6	68.2
14W	7,000	13.15	—	—	—	—	—	—	—	94	150	11	145	4	6	67.4
16T	8,000	14.60	—	—	—	—	—	—	—	94	150	10	145	4	6	59.0
17W	8,500	16.12	—	—	—	—	—	—	—	94	175	11	169	4	6	64.8
18T	9,000	16.67	—	—	—	—	—	—	—	94	175	11	169	4	6	61.2
21W	10,500	20.39	94	140	6.9	135	3	6	41.9	141	220	11	212	5	6	65.9
22T	11,000	21.18	94	140	6.6	135	3	6	40.0	141	220	10	212	5	6	62.9
25T	12,500	23.45	94	140	6.0	135	3	6	35.2	141	250	11	241	6	6	62.9
25W	12,500	22.71	94	140	6.2	135	3	6	35.2	141	250	11	241	6	6	62.9
30T	15,000	29.05	94	140	4.8	135	3	6	29.4	141	275	9	265	6	6	57.7
30W	15,000	28.68	94	140	4.9	135	3	6	29.4	141	275	10	265	6	6	57.7
35T	17,500	34.61	94	187	5.4	180	4	6	33.6	188	350	10	337	8	6	62.9
36W	18,000	37.33	94	187	5.0	180	4	6	32.7	188	350	9	337	8	6	61.2
37T	18,500	36.24	94	187	5.2	180	4	6	31.8	188	350	10	337	8	6	59.5
40W	20,000	41.14	94	187	4.5	180	4	6	29.4	188	400	10	385	9	6	62.9
42T	21,000	41.12	94	187	4.5	180	4	6	28.0	188	400	10	385	9	6	59.9
50W	25,000	51.65	94	233	4.5	224	5	6	29.3	234	500	10	482	11	6	62.9
51T	25,500	50.01	94	233	4.7	224	5	6	28.7	234	500	10	482	11	6	61.7
58T	29,000	56.87	94	280	4.9	270	6	6	30.4	281	505	9	487	11	6	54.8
61W	30,500	62.01	94	280	4.5	270	6	6	28.9	281	505	8	487	11	6	52.1
72W	36,000	71.71	94	327	4.6	315	7	6	28.6	328	505	7	487	11	6	44.1
85W	42,500	85.01	94	327	3.8	315	7	6	24.2	328	505	6	487	11	6	37.4
96W	48,000	95.98	94	374	3.9	360	8	6	24.5	375	505	5	487	11	6	33.1
110W	55,000	110.20	94	374	3.4	360	8	6	21.4	375	505	5	487	11	6	28.9
600V, VAV, Open Elements, Standard Controls without Disconnect																
03W	1,500	1.33	5	9	6.8	11	1	3	18.9	—	—	—	—	—	—	—
06W	3,000	2.45	3	16	6.5	19	1	3	16.8	—	—	—	—	—	—	—
07T	3,500	3.56	3	24	6.7	29	1	3	21.6	—	—	—	—	—	—	—
08W	4,000	3.52	3	23	6.5	28	1	3	18.1	—	—	—	—	—	—	—
09T	4,500	3.81	3	25	6.6	30	1	3	17.5	—	—	—	—	—	—	—
10W	5,000	4.77	3	32	6.7	39	1	3	20.1	—	—	—	—	—	—	—
11T	5,500	5.13	3	34	6.6	41	1	3	19.4	—	—	—	—	—	—	—
12T	6,000	5.69	3	38	6.7	46	1	3	19.9	—	—	—	—	—	—	—
12W	6,000	5.97	6	40	6.7	48	2	3	21.0	—	—	—	—	—	—	—
14W	7,000	6.58	6	44	6.7	53	2	3	19.8	—	—	—	—	—	—	—
16T	8,000	7.30	3	49	6.7	59	2	3	19.3	—	—	—	—	—	—	—
17W	8,500	8.06	3	54	6.7	65	2	3	20.0	—	—	—	—	—	—	—
18T	9,000	8.33	3	55	6.6	66	2	3	19.2	—	—	—	—	—	—	—
21W	10,500	10.20	3	68	6.7	82	2	6	20.4	—	—	—	—	—	—	—
22T	11,000	10.59	3	70	6.6	84	2	6	20.0	—	—	—	—	—	—	—
25T	12,500	11.73	3	78	6.7	94	2	6	19.6	—	—	—	—	—	—	—
25W	12,500	11.36	3	76	6.7	92	2	6	19.1	—	—	—	—	—	—	—
30T	15,000	14.52	3	97	6.7	117	3	6	20.3	—	—	—	—	—	—	—
30W	15,000	14.34	3	96	6.7	116	3	6	20.1	—	—	—	—	—	—	—
35T	17,500	17.31	3	115	6.6	138	3	6	20.7	—	—	—	—	—	—	—
36W	18,000	18.67	3	124	6.6	149	4	6	21.7	—	—	—	—	—	—	—
37T	18,500	18.12	6	120	6.6	145	4	6	20.4	—	—	—	—	—	—	—
40W	20,000	20.57	3	137	6.7	165	4	6	21.5	—	—	—	—	—	—	—
42T	21,000	20.56	6	137	6.7	165	4	6	20.5	—	—	—	—	—	—	—
50W	25,000	25.83	3	172	6.7	207	5	6	21.6	—	—	—	—	—	—	—
51T	25,500	25.00	6	166	6.6	200	5	6	20.5	—	—	—	—	—	—	—
58T	29,000	28.43	5	189	6.6	228	5	6	20.5	—	—	—	—	—	—	—
61W	30,500	31.01	6	206	6.6	248	6	6	21.2	—	—	—	—	—	—	—
72W	36,000	35.86	6	238	6.6	287	6	6	20.8	—	—	—	—	—	—	—
85W	42,500	42.50	6	283	6.7	341	8	6	20.9	—	—	—	—	—	—	—
96W	48,000	47.99	6	319	6.6	384	9	6	20.9	—	—	—	—	—	—	—
110W	55,000	55.10	6	366	6.6	441	10	6	20.9	—	—	—	—	—	—	—

Electric Heater Data (cont)

39M UNIT SIZE	AIRFLOW	FACE AREA	LOW kW EH							HIGH kW EH						
			MIN kW	MAX kW	kW / SQ FT	MAX AMPS	SUB CIRCUITS AT MAX AMPS	CONTROL CIRCUITS AT MAX kW (SEE NOTE 1)	TEMP RISE AT 100% AIRFLOW	MIN kW	MAX kW	kW / SQ FT	MAX AMPS	SUB CIRCUITS AT MAX AMPS	CONTROL CIRCUITS AT MAX kW (SEE NOTE 1)	TEMP RISE AT 100% AIRFLOW
600V, VAV, Open Elements, Standard Controls with Full SCR																
03W	1,500	1.33	1	19	14.3	23	1	3	39.8	—	—	—	—	—	—	
06W	3,000	2.45	1	37	15.1	45	1	3	38.8	38	47	19	57	2	3	49.3
07T	3,500	3.56	1	37	10.4	45	1	3	33.3	38	70	20	84	2	6	62.9
08W	4,000	3.52	1	68	19.3	82	2	6	53.5	—	—	—	—	—	—	
09T	4,500	3.81	1	74	19.4	89	2	6	51.7	—	—	—	—	—	—	
10W	5,000	4.77	1	74	15.5	89	2	6	46.6	—	—	—	—	—	—	
11T	5,500	5.13	1	74	14.4	89	2	6	42.3	—	—	—	—	—	—	
12T	6,000	5.69	1	74	13.0	89	2	6	38.8	—	—	—	—	—	—	
12W	6,000	5.97	2	74	12.4	89	2	6	38.8	—	—	—	—	—	—	
14W	7,000	6.58	2	74	11.3	89	2	6	33.3	—	—	—	—	—	—	
16T	8,000	7.30	1	74	10.1	89	2	6	29.1	—	—	—	—	—	—	
17W	8,500	8.06	2	74	9.2	89	2	6	27.4	—	—	—	—	—	—	
18T	9,000	8.33	1	74	8.9	89	2	6	25.9	—	—	—	—	—	—	
21W	10,500	10.20	2	74	7.3	89	2	6	22.2	—	—	—	—	—	—	
22T	11,000	10.59	2	74	7.0	89	2	6	21.2	—	—	—	—	—	—	
25T	12,500	11.73	2	74	6.3	89	2	6	18.6	—	—	—	—	—	—	
25W	12,500	11.36	2	74	6.5	89	2	6	18.6	—	—	—	—	—	—	
30T	15,000	14.52	2	74	5.1	89	2	6	15.5	—	—	—	—	—	—	
30W	15,000	14.34	2	74	5.2	89	2	6	15.5	—	—	—	—	—	—	
35T	17,500	17.31	2	74	4.3	89	2	6	13.3	—	—	—	—	—	—	
36W	18,000	18.67	3	74	4.0	89	2	6	12.9	—	—	—	—	—	—	
37T	18,500	18.12	3	74	4.1	89	2	6	12.6	—	—	—	—	—	—	
40W	20,000	20.57	3	74	3.6	89	2	6	11.6	—	—	—	—	—	—	
42T	21,000	20.56	3	74	3.6	89	2	6	11.1	—	—	—	—	—	—	
50W	25,000	25.83	3	74	2.9	89	2	6	9.3	—	—	—	—	—	—	
51T	25,500	25.00	4	74	3.0	89	2	6	9.1	—	—	—	—	—	—	
58T	29,000	28.43	4	74	2.6	89	2	6	8.0	—	—	—	—	—	—	
61W	30,500	31.01	4	74	2.4	89	2	6	7.6	—	—	—	—	—	—	
72W	36,000	35.86	5	74	2.1	89	2	6	6.5	—	—	—	—	—	—	
85W	42,500	42.50	5	74	1.7	89	2	6	5.5	—	—	—	—	—	—	
96W	48,000	47.99	5	74	1.5	89	2	6	4.8	—	—	—	—	—	—	
110W	55,000	55.10	5	74	1.3	89	2	6	4.2	—	—	—	—	—	—	

Electric Heater Data (cont)

39M UNIT SIZE	AIRFLOW	FACE AREA	LOW kW EH							HIGH kW EH						
			MIN kW	MAX kW	kW / SQ FT	MAX AMPS	SUB CIRCUITS AT MAX AMPS	CONTROL CIRCUITS AT MAX kW (SEE NOTE 1)	TEMP RISE AT 100% AIRFLOW	MIN kW	MAX kW	kW / SQ FT	MAX AMPS	SUB CIRCUITS AT MAX AMPS	CONTROL CIRCUITS AT MAX kW (SEE NOTE 1)	TEMP RISE AT 100% AIRFLOW
600V, VAV, Open Elements, Standard Controls with Vernier SCR																
11T	5,500	5.13	75	130	25.3	157	4	6	74.4	—	—	—	—	—	—	—
12T	6,000	5.69	75	130	22.8	157	4	6	68.2	—	—	—	—	—	—	—
12W	6,000	5.97	75	130	21.8	157	4	6	68.2	—	—	—	—	—	—	—
14W	7,000	6.58	75	149	22.7	179	4	6	67.0	—	—	—	—	—	—	—
16T	8,000	7.30	75	150	20.6	181	4	6	59.0	—	—	—	—	—	—	—
17W	8,500	8.06	75	149	18.5	179	4	6	55.1	—	—	—	—	—	—	—
18T	9,000	8.33	75	170	20.4	205	5	6	59.4	—	—	—	—	—	—	—
21W	10,500	10.20	75	112	11.0	135	3	6	33.6	113	149	15	179	4	6	44.6
22T	11,000	10.59	75	112	10.6	135	3	6	32.0	113	220	21	265	6	6	62.9
25T	12,500	11.73	75	112	9.6	135	3	6	28.2	113	224	19	270	6	6	56.4
25W	12,500	11.36	75	112	9.9	135	3	6	28.2	113	149	13	179	4	6	37.5
30T	15,000	14.52	75	112	7.7	135	3	6	23.5	113	224	15	270	6	6	47.0
30W	15,000	14.34	75	112	7.8	135	3	6	23.5	113	149	10	179	4	6	31.2
35T	17,500	17.31	75	149	8.6	179	4	6	26.8	150	224	13	270	6	6	40.3
36W	18,000	18.67	75	149	8.0	179	4	6	26.0	150	224	12	270	6	6	39.1
37T	18,500	18.12	75	149	8.2	179	4	6	25.3	150	299	17	360	8	6	50.8
40W	20,000	20.57	75	149	7.2	179	4	6	23.4	150	224	11	270	6	6	35.2
42T	21,000	20.56	75	149	7.2	179	4	6	22.3	150	300	15	361	8	6	44.9
50W	25,000	25.83	75	187	7.2	225	5	6	23.5	188	224	9	270	6	6	28.2
51T	25,500	25.00	75	187	7.5	225	5	6	23.1	188	374	15	450	10	6	46.1
58T	29,000	28.43	75	224	7.9	270	6	6	24.3	225	374	13	450	10	6	40.6
61W	30,500	31.01	75	224	7.2	270	6	6	23.1	225	374	12	450	10	6	38.6
72W	36,000	35.86	75	261	7.3	314	7	6	22.8	262	374	10	450	10	6	32.7
85W	42,500	42.50	75	261	6.1	314	7	6	19.3	262	374	9	450	10	6	27.7
96W	48,000	47.99	75	299	6.2	360	8	6	19.6	300	374	8	450	10	6	24.5
110W	55,000	55.10	75	299	5.4	360	8	6	17.1	300	374	7	450	10	6	21.4

LEGEND

- AHRI** — Air-Conditioning, Heating and Refrigeration Institute
- FLA** — Full Load Amps
- MCA** — Minimum Circuit Amps
- SCR** — Silicon Control Rectifier

NOTE(S):

1. Standard control steps are listed under the Control Step heading. "Free" additional steps of control are optionally available when the number of sub-circuits exceeds the standard number of control steps.
2. MCA = 1.25 x FLA; for proper wire sizing, refer to Table 310-16 of the NEC (National Electrical Code).
3. Sub-circuits are internal heater circuits of 48 amps or less.
4. Electric heat performance is not within the scope of AHRI standard 430 certification.
5. To avoid damage due to overheating, minimum face velocity cannot fall below 350 fpm.
6. Heaters up to (and including) 60 kW have 3 control steps; beyond 60 kW, 6 steps are standard.
7. Heater kW offering is controlled by **AHUBuilder®** program. This table is for reference only.

Fan Offerings by Unit Size and Type

39M UNIT SIZE	FORWARD CURVE FANS											
	SUPPLY						RETURN / EXHAUST					
	FAN WHEEL	HP / FRAME		FAN WHEEL	HP / FRAME		FAN WHEEL	HP / FRAME		FAN WHEEL	HP / FRAME	
MAX		MIN	MAX		MIN	MAX		MIN	MAX		MIN	
03W	N/A	N/A	N/A	A9-4A	5 / 184T	0.5 / 56	N/A	N/A	N/A	A9-4A	5 / 184T	0.5 / 56
06W	A10-8A	5 / 184T	0.75 / 56	A10-8A	5 / 184T	0.75 / 56	A9-4A	5 / 184T	0.5 / 56	A10-8A	5 / 184T	0.75 / 56
07T	A10-8A	7.5 / 213T	0.5 / 56	A-12-12A	7.5 / 213T	0.5 / 56	A10-8A	7.5 / 213T	0.5 / 56	A12-12A	7.5 / 213T	0.5 / 56
08W	A10-8A	7.5 / 213T	3 / 182T	A12-12A	5 / 184T	0.75 / 56	A10-8A	7.5 / 213T	3 / 182T	A12-12A	5 / 184T	0.75 / 56
09T	A10-8A	7.5 / 213T	0.5 / 56	A12-12A	7.5 / 213T	0.5 / 56	A10-8A	7.5 / 213T	0.5 / 56	A12-12A	7.5 / 213T	0.5 / 56
10W	A12-12A	10 / 215T	5 / 184T	A15-15A	5 / 184T	1 / 143T	A12-12A	10 / 215T	5 / 184T	A15-15A	5 / 184T	1 / 143T
11T	A12-12A	10 / 215T	0.75 / 56	A15-15A	10 / 215T	0.75 / 56	A12-12A	10 / 215T	0.75 / 56	A15-15A	10 / 215T	0.75 / 56
12T	A12-12A	10 / 215T	0.75 / 56	A15-15A	10 / 215T	0.75 / 56	A12-12A	10 / 215T	0.75 / 56	A15-15A	10 / 215T	0.75 / 56
12W	A12-11A	15 / 254T	5 / 184T	A15-15A	7.5 / 213T	1.5 / 145T	A12-12A	10 / 215T	5 / 184T	A15-15A	7.5 / 213T	1.5 / 145T
14W	A15-15A	15 / 254T	5 / 184T	A18-18A	7.5 / 213T	1.5 / 145T	A15-15A	15 / 254T	5 / 184T	A18-18A	7.5 / 213T	1.5 / 145T
16T	A-15-15A	5 / 184T	15 / 254T	A18-18A	1.5 / 145T	10 / 215T	A-15-15A	5 / 184T	15 / 254T	A18-18A	1.5 / 145T	10 / 215T
17W	A15-15A	25 / 284T	7.5 / 213T	A18-18A	10 / 215T	1.5 / 145T	A15-15A	25 / 284T	7.5 / 213T	A18-18A	10 / 215T	1.5 / 145T
18T	A-15-15A	7.5 / 213T	25 / 284T	A18-18A	1.5 / 145T	11 / 215T	A-15-15A	7.5 / 213T	25 / 284T	A18-18A	1.5 / 145T	11 / 215T
21W	A15-15A	25 / 284T	7.5 / 213T	A20-18A	15 / 254T	2 / 145T	A18-18A	10 / 215T	1.5 / 145T	A20-18A	15 / 254T	2 / 145T
22T	A-15-15A	7.5 / 213T	26 / 284T	A20-18A	2 / 145T	15 / 254T	A-15-15A	7.5 / 213T	26 / 284T	A20-18A	2 / 145T	15 / 254T
25T	A20-15A	10 / 215T	25 / 284T	A20-18A	3 / 145T	16 / 254T	A20-15A	10 / 215T	25 / 284T	A20-18A	3 / 145T	16 / 254T
25W	A20-15A	25 / 284T	10 / 215T	A20-18A	15 / 254T	2 / 145T	A18-18A	10 / 215T	1.5 / 145T	A20-18A	15 / 254T	2 / 145T
30T	A20-18H	10 / 215T	30 / 286T	A20-20H	3 / 182T	20 / 256T	A20-18H	10 / 215T	30 / 286T	A20-20H	3 / 182T	20 / 256T
30W	A20-18H	30 / 286T	10 / 215T	A20-20H	20 / 256T	3 / 182T	A20-18H	30 / 286T	10 / 215T	A20-20H	20 / 256T	3 / 182T
35T	A20-20H	3 / 182T	20 / 256T	A22-22H	15 / 254T	30 / 286T	A20-20H	3 / 182T	20 / 256T	A22-22H	15 / 254T	30 / 286T
36W	A22-22H	30 / 286T	15 / 254T	A25-25H	25 / 284T	3 / 182T	A20-20H	20 / 256T	3 / 182T	A25-25H	25 / 284T	3 / 182T
37T	A22-22H	15 / 254T	30 / 286T	A25-25H	3 / 182T	25 / 284T	A22-22H	15 / 254T	30 / 286T	A25-25H	3 / 182T	25 / 284T
40W	A25-20H	30 / 286T	15 / 254T	A25-25H	25 / 284T	3 / 182T	A20-20H	20 / 256T	3 / 182T	A25-25H	25 / 284T	3 / 182T
42T	A25-20H	30 / 286T	3 / 182T	A25-25H	30 / 286T	3 / 182T	A25-20H	30 / 286T	3 / 182T	A25-25H	30 / 286T	3 / 182T
50W	A27-22H	40 / 324T	15 / 254T	A27-27H	30 / 286T	5 / 184T	A25-25H	25 / 284T	3 / 182T	A27-27H	30 / 286T	5 / 184T
51T	A27-22H	40 / 324T	3 / 182T	A27-27H	40 / 324T	3 / 182T	A27-22H	40 / 324T	3 / 182T	A27-27H	40 / 324T	3 / 182T
58T	A27-27H	50 / 326T	5 / 184T	A30-30H	40 / 324T	3 / 182T	A27-27H	50 / 326T	5 / 184T	A30-30H	40 / 324T	3 / 182T
61W	A27-27H	50 / 326T	20 / 256T	A30-30H	40 / 324T	5 / 184T	A27-27H	50 / 326T	20 / 256T	A30-30H	40 / 324T	5 / 184T
72W	32	75 / 365T	10 / 215T	36	75 / 365T	10 / 215T	32	75 / 365T	10 / 215T	36	75 / 365T	10 / 215T
85W	36	75 / 365T	10 / 215T	40	75 / 365T	10 / 215T	36	75 / 365T	10 / 215T	40	75 / 365T	10 / 215T
96W	N/A	N/A	N/A	40	75 / 365T	10 / 215T	N/A	N/A	N/A	40	75 / 365T	10 / 215T
110W	N/A	N/A	N/A	40	75 / 365T	10 / 215T	N/A	N/A	N/A	40	75 / 365T	10 / 215T

Fan Offerings by Unit Size and Type (cont)

39M UNIT SIZE	AIRFOIL FANS											
	SUPPLY						RETURN / EXHAUST					
	A			B			A			B		
	FAN WHEEL	HP / FRAME		FAN WHEEL	HP / FRAME		FAN WHEEL	HP / FRAME		FAN WHEEL	HP / FRAME	
MAX		MIN	MAX		MIN	MAX		MIN	MAX		MIN	
03W	N/A	N/A	N/A	101	5 / 184T	0.5 / 56	N/A	N/A	N/A	101	5 / 184T	0.5 / 56
06W	101	5 / 184T	0.5 / 56	121	7.5 / 184T	0.5 / 56	101	5 / 184T	0.5 / 56	121	7.5 / 184T	0.5 / 56
07T	121	10 / 215T	1 / 143T	131	15 / 254T	1.5 / 145T	121	10 / 215T	1 / 143T	131	15 / 254T	1.5 / 145T
08W	121	7.5 / 184T	0.5 / 56	131	10 / 215T	1 / 143T	121	7.5 / 184T	0.5 / 56	131	10 / 215T	1 / 143T
09T	121	10 / 215T	1 / 143T	131	15 / 254T	1.5 / 145T	121	10 / 215T	1 / 143T	131	15 / 254T	1.5 / 145T
10W	121	7.5 / 184T	0.5 / 56	131	15 / 254T	1.5 / 145T	121	7.5 / 184T	0.5 / 56	131	15 / 254T	1.5 / 145T
11T	131	15 / 254T	1.5 / 145T	161	20 / 256T	1.5 / 145T	131	15 / 254T	1.5 / 145T	161	20 / 256T	1.5 / 145T
12T	131	15 / 254T	1.5 / 145T	161	20 / 256T	1.5 / 145T	131	15 / 254T	1.5 / 145T	161	20 / 256T	1.5 / 145T
12W	131	15 / 254T	1.5 / 145T	161	15 / 254T	1.5 / 145T	131	15 / 254T	1.5 / 145T	161	15 / 254T	1.5 / 145T
14W	131	15 / 254T	1.5 / 145T	161	20 / 256T	1.5 / 145T	131	15 / 254T	1.5 / 145T	161	20 / 256T	1.5 / 145T
16T	131	1.5 / 145T	15 / 254T	161	1.5 / 145T	20 / 256T	131	1.5 / 145T	15 / 254T	161	1.5 / 145T	20 / 256T
17W	161	20 / 256T	1.5 / 145T	181	20 / 256T	1.5 / 145T	161	20 / 256T	1.5 / 145T	181	20 / 256T	1.5 / 145T
18T	161	1.5 / 145T	20 / 256T	181	1.5 / 145T	20 / 256T	161	1.5 / 145T	20 / 256T	181	1.5 / 145T	20 / 256T
21W	181	20 / 256T	1.5 / 145T	201	25 / 284T	2 / 145T	181	20 / 256T	1.5 / 145T	201	25 / 284T	2 / 145T
22T	181	1.5 / 145T	20 / 256T	201	2 / 145T	25 / 284T	181	1.5 / 145T	20 / 256T	201	2 / 145T	25 / 284T
25T	201	2 / 145T	25 / 284T	221	2 / 145T	30 / 286T	201	2 / 145T	25 / 284T	221	2 / 145T	30 / 286T
25W	201	25 / 284T	2 / 145T	221	30 / 286T	2 / 145T	201	25 / 284T	2 / 145T	221	30 / 286T	2 / 145T
30T	221	3 / 182T	40 / 324T	221	5 / 184T	40 / 324T	221	3 / 182T	40 / 324T	221	5 / 184T	40 / 324T
30W	N/A	N/A	N/A	221	40 / 324T	3 / 182T	N/A	N/A	N/A	221	40 / 324T	3 / 182T
35T	241	5 / 184T	40 / 324T	271	3 / 182T	15 / 254T	241	5 / 184T	40 / 324T	271	3 / 182T	15 / 254T
36W	271	40 / 324T	3 / 182T	241	40 / 324T	5 / 184T	241	40 / 324T	5 / 184T	271	40 / 324T	3 / 182T
37T	241	5 / 184T	40 / 324T	271	3 / 182T	15 / 254T	241	5 / 184T	40 / 324T	271	3 / 182T	15 / 254T
40W	301	50 / 326T	3 / 182T	271	50 / 326T	5 / 184T	271	50 / 326T	5 / 184T	301	50 / 326T	3 / 182T
42T	271	40 / 324T	5 / 184T	301	50 / 326T	3 / 182T	271	40 / 324T	5 / 184T	301	50 / 326T	3 / 182T
50W	331	60 / 364T	5 / 184T	301	60 / 364T	7.5 / 213T	301	60 / 364T	7.5 / 213T	331	60 / 364T	5 / 184T
51T	301	60 / 364T	7.5 / 213T	331	40 / 324T	5 / 184T	301	60 / 364T	7.5 / 213T	331	40 / 324T	5 / 184T
58T	331	60 / 364T	5 / 184T	361	60 / 364T	5 / 184T	331	60 / 364T	5 / 184T	361	60 / 364T	5 / 184T
61W	301	60 / 364T	7.5 / 213T	331	75 / 365T	7.5 / 213T	331	75 / 365T	7.5 / 213T	361	20 / 256T	5 / 184T
72W	32	75 / 365T	7.5 / 213T	36	100 / 405T	7.5 / 213T	32	75 / 365T	7.5 / 213T	36	100 / 405T	7.5 / 213T
85W	36	100 / 405T	7.5 / 213T	40	125 / 444T	10 / 215T	36	100 / 405T	7.5 / 213T	40	125 / 444T	10 / 215T
96W	36	100 / 405T	7.5 / 213T	40	125 / 444T	10 / 215T	36	100 / 405T	7.5 / 213T	40	125 / 444T	10 / 215T
110W	40	125 / 444T	10 / 215T	44	150 / 445T	15 / 254T	40	125 / 444T	10 / 215T	44	150 / 445T	15 / 254T

Fan Offerings by Unit Size and Type (cont)

DIRECT DRIVE PLENUM FANS WITH NEMA MOTORS									
39M UNIT SIZE	SUPPLY/RETURN/EXHAUST								
	FAN WHEEL Size A	HP / FRAME		FAN WHEEL Size B	HP / FRAME		FAN WHEEL Size C	HP / FRAME	
		MAX	MIN		MAX	MIN		MAX	MIN
03W	105	5 / 184T	0.5 / 56	122	5 / 184T	0.5 / 56	N/A	N/A	N/A
06W	135	7.5 / 213T	1 / 143T	150	7.5 / 215T	1 / 143T	165	10 / 215T	1 / 143T
07T	135	7.5 / 213T	1 / 143T	150	7.5 / 215T	1 / 143T	165	10 / 215T	1 / 143T
08W	150	7.5 / 215T	1 / 143T	165	10 / 215T	1 / 143T	182	15 / 254T	1 / 143T
09T	150	7.5 / 215T	1 / 143T	165	10 / 215T	1 / 143T	182	15 / 254T	1 / 143T
10W	165	10 / 215T	1 / 143T	182	15 / 254T	1 / 143T	200	15 / 256T	1 / 143T
11T	165	10 / 215T	1 / 143T	182	15 / 254T	1 / 143T	200	15 / 256T	1 / 143T
12T	182	15 / 254T	1 / 143T	200	15 / 256T	1 / 143T	222	20 / 256T	1 / 143T
12W	182	15 / 254T	1 / 143T	200	15 / 254T	1 / 143T	222	20 / 256T	1 / 143T
14W	200	15 / 254T	1 / 143T	222	20 / 256T	1 / 143T	245	20 / 256T	1.5 / 182T
16T	200	15 / 256T	1 / 143T	222	20 / 256T	1 / 143T	245	20 / 256	1.5 / 182T
17W	222	20 / 256T	1 / 143T	245	20 / 256T	1.5 / 182T	270	25 / 284T	2 / 184T
18T	222	20 / 256T	1 / 143T	245	20 / 256T	1.5 / 182T	270	25 / 284T	2 / 184T
21W	245	20 / 256T	1.5 / 182T	270	25 / 284T	2 / 184T	300	30 / 324T	3 / 213T
22T	245	20 / 256T	1.5 / 182T	270	25 / 284T	2 / 184T	300	30 / 286T	3 / 213T
25T	270	25 / 284T	2 / 184T	300	30 / 286T	3 / 213T	330	40 / 364T	5/215T
25W	270	25 / 284T	2 / 184T	300	30 / 326T	3 / 213T	330	40 / 364T	5 / 215T
30T	270	25 / 284T	2 / 184T	330	40 / 364T	5 / 215T	365	50 / 364T	10 / 256T
30W	270	25 / 284T	2 / 184T	330	40 / 364T	6 / 215T	365	50 / 364T	10 / 256T
35T	300	30 / 286T	3 / 213T	330	40 / 364T	5 / 215T	365	50 / 364T	10 / 256T
36W	300	30 / 326T	3 / 213T	365	50 / 364T	10 / 256T	402	50 / 365T	10 / 256T
37T	330	40 / 364T	5 / 215T	365	50 / 364T	10 / 256T	402	50 / 365T	10 / 256T
40W	330	40 / 364T	5 / 215T	365	50 / 364T	10 / 256T	402	50 / 365T	10 / 256T
42T	330	40 / 364T	5 / 215T	365	50 / 364T	10 / 256T	402	50 / 365T	10 / 256T
50W	365	50 / 364T	10 / 256T	402	50 / 365T	10 / 256T	N/A	N/A	N/A
51T	365	50 / 364T	10 / 256T	402	50 / 365T	10 / 256T	N/A	N/A	N/A
58T	365	50 / 364T	10 / 256T	402	50 / 365T	10 / 256T	N/A	N/A	N/A
61W	365	50 / 364T	10 / 256T	402	50 / 365T	10 / 256T	N/A	N/A	N/A

DIRECT DRIVE PLENUM FAN ARRAYS WITH NEMA T FRAME MOTORS									
39M UNIT SIZE	SUPPLY/RETURN/EXHAUST								
	2 FAN WHEELS	HP / FRAME		4 FAN WHEELS	HP / FRAME		6 FAN WHEELS	HP / FRAME	
		MAX	MIN		MAX	MIN		MAX	MIN
08W	135	7.5 / 213T	1 / 143T	N/A	N/A	N/A	N/A	N/A	N/A
10W	150	7.5 / 215T	1 / 143T	N/A	N/A	N/A	N/A	N/A	N/A
12W	165	10 / 215T	1 / 143T	N/A	N/A	N/A	N/A	N/A	N/A
14W	165	10 / 215T	1 / 143T	N/A	N/A	N/A	N/A	N/A	N/A
17W	182	15 / 254T	1 / 143T	N/A	N/A	N/A	N/A	N/A	N/A
21W	182	15 / 254T	1 / 143T	N/A	N/A	N/A	N/A	N/A	N/A
25W	222	20 / 256T	1 / 143T	N/A	N/A	N/A	N/A	N/A	N/A
30W	222	20 / 256T	1 / 143T	N/A	N/A	N/A	N/A	N/A	N/A
36W	270	25 / 284T	5 / 184T	N/A	N/A	N/A	N/A	N/A	N/A
40W	270	25 / 284T	5 / 184T	182	15 / 254T	1 / 143T	N/A	N/A	N/A
50W	300	30 / 324T	7.5 / 213T	222	20 / 256T	1 / 143T	182	15 / 254T	1 / 143T
61W	330	40 / 364T	10 / 215T	245	20 / 256T	3 / 182T	182	15 / 254T	1 / 143T
72W	365	50 / 364T	20 / 256T	N/A	N/A	N/A	222	20 / 256T	1 / 143T
85W	402	50 / 365T	20 / 256T	N/A	N/A	N/A	245	20 / 256T	3 / 182T
96W	N/A	N/A	N/A	N/A	N/A	N/A	245	20 / 256T	3 / 182T
110W	N/A	N/A	N/A	N/A	N/A	N/A	245	20 / 256T	3 / 182T

Fan Offerings by Unit Size and Type (cont)

DIRECT DRIVE PLENUM FAN ASSEMBLIES WITH EC MOTORS OFFERING																		
EBM-PAPST, HORIZONTAL																		
39M UNIT SIZE	TSP;MAX (in. wg)	# FAN	WHEEL SIZE	39M UNIT SIZE	TSP;MAX (in. wg)	# FAN	WHEEL SIZE	39M UNIT SIZE	TSP;MAX (in. wg)	# FAN	WHEEL SIZE	39M UNIT SIZE	TSP;MAX (in. wg)	# FAN	WHEEL SIZE			
03W	4	1	310	16T	4	1	500	35T	4	3	450	58T	4	4	500			
	4	1	310		4	2	500		6	4	450		4	5	450			
06W	6	1	400		6	2	450		6	5	450		4	6	450			
	8	1	400		6	4	310		6	6	450		6	5	500			
	4	1	400		8	2	400		8	5	400		6	6	500			
07T	4	2	310		8	3	400		8	6	400		8	8	400			
	4	2	400		4	2	400		4	3	450		8	9	400			
	6	1	450		17W	4	3		400	4	4		450	4	4	500		
6	2	400	6			2	450	6	4	450	4		5	500				
8	1	400	8			3	400	6	5	450	6	6	450					
07W	4	1	400	4	2	400	36W	6	6	450	61W	6	7	450				
	4	2	310	4	3	400		8	5	400		8	8	400				
08W	4	2	400	6	2	450		8	6	400		8	9	400				
	6	1	450	18T	6	4		400	4	3		450	4	5	500			
	6	2	400		8	3		400	4	5		400	4	6	450			
8	1	400	8		4	400		6	4	450		4	6	500				
4	1	400	4		2	450		6	5	450	4	7	450					
09T	4	2	400	21W	6	2		500	37T	6	6	450	72W	6	7	500		
	6	1	450		8	3	400	8		5	400	6		8	500			
	8	2	400		8	4	400	8		6	400	6		10	450			
4	1	450	4		2	450	4	3		500	8	9		400				
10W	4	2	450	22T	4	3	450	40W		4	4	500		85W	8	10	400	
	4	3	310		6	2	500			4	5	450			4	6	500	
	6	1	500		6	3	500			6	4	450	4		7	500		
	8	3	310		8	3	400			6	5	450	6		8	500		
	8	3	400		8	4	400		8	5	400	6	9		500			
11T	4	1	450	25W	4	2	450		42T	8	6	400	96W		6	10	450	
	4	2	450		4	3	450			4	3	500			6	11	450	
	6	1	500		6	3	450			6	4	500			8	11	400	
	6	2	500		8	4	400	6		5	450	8			12	400		
	8	2	400		8	5	400	8		6	400	4			6	500		
12W	4	1	45	25T	4	2	450	50W		6	5	500			110W	4	7	500
	4	2	450		4	3	450			6	6	450				4	8	450
	6	2	400		6	3	450			8	6	400		4		9	450	
	6	3	400		6	4	450		8	7	400	6		9		500		
	8	2	400		8	4	400		4	4	450	8		10		500		
	8	3	400		8	5	400		6	5	450	8		12		400		
12T	4	1	450	30W	4	2	500	51T	6	6	450	110W		8	13	400		
	4	3	310		4	3	500		6	7	450		4	7	500			
	4	4	310		6	3	450		8	7	400		4	8	500			
	6	2	400		8	4	400		8	8	400		6	10	500			
	6	3	400		8	5	400		4	4	450		6	11	500			
	8	2	400		4	2	500		4	5	450		8	14	400			
14W	4	1	500	30T	4	3	500	51T	6	5	500	110W	8	15	400			
	4	2	500		6	3	450		6	6	450		6	11	500			
	6	2	450		6	4	450		6	6	500		8	14	400			
	6	3	400		8	4	400		8	7	400		8	15	400			
	8	2	400		8	5	400		8	8	400							

Fan Offerings by Unit Size and Type (cont)

DIRECT DRIVE PLENUM FAN ASSEMBLIES WITH EC MOTORS OFFERING																
EBM-PAPST, VERTICAL																
39M UNIT SIZE	TSP;MAX (in. wg)	# FAN	WHEEL SIZE	39M UNIT SIZE	TSP;MAX (in. wg)	# FAN	WHEEL SIZE	39M UNIT SIZE	TSP;MAX (in. wg)	# FAN	WHEEL SIZE	39M UNIT SIZE	TSP;MAX (in. wg)	# FAN	WHEEL SIZE	
03W	4	1	310	12W	4	1	450	21W	4	2	450	40W	4	3	500	
	4	2	310		4	2	450		4	4	400		4	4	500	
06W	4	1	310		4	4	310		6	2	500		4	5	450	
	4	2	310		4	5	310		6	5	400		6	4	450	
	6	1	400		6	2	400		8	3	400		6	5	450	
	6	2	400		8	2	400		8	4	400		6	6	450	
	8	1	400		8	3	400	4	2	450	8	5	400			
	8	2	400		8	3	400	4	3	450	8	6	400			
08W	4	1	400		14W	4	1	500	25W	6	3	450	50W	4	4	450
	4	2	310			4	2	500		6	5	400		6	5	450
	4	2	400	4		4	310	8		4	400	6		6	450	
	6	1	450	4		5	310	8		5	400	6		7	450	
	6	2	400	6		2	450	4	2	500	8	7		400		
	8	1	400	6		3	400	8	2	400	4	3		500	8	8
10W	4	1	450	17W	8	2	400	30W	6	3	450	61W	4	4	500	
	4	2	450		4	2	400		6	6	400		4	5	500	
	4	3	310		4	3	400		8	4	400		6	6	500	
	4	4	310		6	2	450		8	5	400		6	7	500	
	6	1	500		8	3	400	4	3	450	8		8	400		
	8	3	310		8	4	400	4	4	450	8		9	400		
	8	3	400		36W	6	4	450	6	4	450					
						6	5	450	6	5	450					
			6	6		450	8	5	400							
			8	5		400	8	6	400							

Fan Offerings by Unit Size and Type (cont)

DIRECT DRIVE PLENUM FAN ASSEMBLIES WITH EC MOTORS OFFERING															
ZIEHL-ABEGG, HORIZONTAL															
39M UNIT SIZE	TSP;MAX (in. wg)	# FAN	WHEEL SIZE	39M UNIT SIZE	TSP;MAX (in. wg)	# FAN	WHEEL SIZE	39M UNIT SIZE	TSP;MAX (in. wg)	# FAN	WHEEL SIZE	39M UNIT SIZE	TSP;MAX (in. wg)	# FAN	WHEEL SIZE
03W	4	1	310	22T	4	2	450	40W	4	4	450	72W	4	6	500
	8	1	310		4	5	310		4	5	450		4	9	450
06W	4	1	310		4	6	310		4	6	450		4	11	400
	6	1	400		6	4	310		6	5	400		6	8	450
07T	4	1	400		8	5	310		6	6	400		6	9	450
	6	1	400		8	6	310		8	6	400		8	11	400
08W	8	2	310	25W	4	2	500	42T	8	10	310	85W	8	12	400
	4	1	400		4	6	310		4	4	450		4	8	450
	4	1	450		6	5	310		4	5	450		4	9	450
	6	1	400		8	6	310		4	6	450		4	10	450
09T	8	2	310	25T	4	2	500	50W	6	5	450	96W	4	11	450
	4	1	400		4	4	400		6	6	450		6	10	450
	6	1	450		6	4	400		8	10	310		6	11	450
	8	2	310		8	6	310		8	11	310		8	19	310
10W	4	1	450	30W	8	4	400	51T	4	4	500	110W	8	20	310
	4	2	400		4	3	450		4	5	500		4	8	500
	6	2	310		4	7	310		4	6	450		4	9	500
	8	2	400		4	8	310		4	8	400		4	11	450
11T	4	1	450	6	6	310	6	6	450	6	6	450			
	6	2	310	8	8	310	8	8	400	6	11	450			
12W	4	1	500	30T	4	3	450	58T	8	8	400	110W	8	12	450
	4	2	400		4	4	450		4	4	500		8	15	400
	6	2	400		4	8	310		4	6	450		8	16	400
12T	8	2	400	6	4	400	61W	4	8	400	110W	4	9	500	
	4	1	500	8	7	310		4	8	400		4	10	500	
	4	2	400	8	8	310		6	6	450		4	15	400	
14W	6	2	400	35T	8	8	310	51T	6	8	400	110W	4	16	400
	4	2	400		4	3	450		8	8	400		6	11	450
	4	2	450		4	4	450		8	13	310		6	12	450
	6	2	400		4	4	450		4	4	500		8	15	400
16T	8	4	310	4	8	310	51T	4	6	450	110W	8	16	400	
	4	2	400	6	4	450		4	8	400		4	9	500	
	4	2	450	8	7	310		6	6	450		4	10	500	
	6	2	400	8	8	310		6	8	400		4	15	400	
17W	8	4	310	36W	4	3	450	58T	8	8	400	110W	6	14	400
	4	2	400		4	4	450		8	9	400		6	15	400
	4	2	450		4	9	310		4	5	450		8	17	400
	6	2	400		6	4	450		4	6	450		8	18	400
18T	4	2	400	8	8	310	61W	4	8	400	110W	4	8	400	
	4	2	450	8	9	310		4	8	400		4	9	400	
	4	5	310	4	3	500		6	7	400		6	7	400	
	4	6	310	4	5	400		4	5	400		6	8	400	
	6	2	450	4	6	400		6	8	400		8	9	400	
	6	5	310	6	5	400		8	9	400		8	14	310	
21W	8	4	310	37T	8	6	400	61W	4	5	500	110W	4	5	500
	4	2	450		4	4	400		4	6	500		4	6	500
	4	5	310		4	5	450		4	9	400		4	9	400
	4	6	310		4	6	450		4	10	400		6	8	400
	6	4	310		6	5	400		6	8	400		6	9	400
	8	5	310		8	6	400		8	10	400		8	10	400
	8	6	310	8	10	310		8	11	400		8	11	400	

Fan Offerings by Unit Size and Type (cont)

DIRECT DRIVE PLENUM FAN ASSEMBLIES WITH EC MOTORS OFFERING																	
ZIEHL-ABEGG, VERTICAL																	
39M UNIT SIZE	TSP;MAX (in. wg)	# FAN	WHEEL SIZE	39M UNIT SIZE	TSP;MAX (in. wg)	# FAN	WHEEL SIZE	39M UNIT SIZE	TSP;MAX (in. wg)	# FAN	WHEEL SIZE	39M UNIT SIZE	TSP;MAX (in. wg)	# FAN	WHEEL SIZE		
03W	4	1	310	10W	4	1	450	17W	4	2	400	36W	4	3	500		
	4	2	310		4	2	400		4	2	450		4	4	500		
	6	2	310		4	2	450		4	3	400		4	5	400		
	6	3	310		4	3	400		4	3	450		4	6	400		
	8	1	310		4	4	310		6	2	450		6	4	450		
	8	2	310		4	5	310		6	3	450		6	5	450		
06W	4	1	310		6	2	310	8	3	400	8	6	400	40W	4	5	450
	4	1	400		6	3	310	8	4	400	4	6	450				
	4	2	310		8	2	400	4	2	450	4	6	450				
	4	2	400		8	3	400	4	3	400	6	5	400				
	4	3	310		8	3	400	4	3	450	6	6	400	6	6	400	
	6	1	400		4	1	500	6	4	400	4	4	400	8	6	400	
	6	2	400	4	2	400	8	4	400	6	3	400	4	4	500		
	6	3	310	4	2	500	4	3	400	6	4	400	4	5	500		
08W	8	1	400	12W	4	3	400	21W	8	4	400	50W	4	6	450		
	8	2	400		4	4	310		4	2	500		6	6	450		
	4	1	400		4	4	400		4	3	450		8	8	400		
	4	1	450		4	5	310		4	3	500		4	5	500		
	4	2	400		6	2	400	6	3	400	4		6	450			
	4	2	450		8	2	400	8	4	400	6		6	450			
	4	3	310		8	3	400	4	2	500	8		8	400			
	4	4	310		4	3	400	4	3	450	4		5	500			
08W	6	1	400	14W	4	2	400	25W	6	4	450	61W	4	6	500		
	6	2	400		4	3	400		6	3	450		4	5	500		
	6	4	310		6	3	400		8	4	400		6	6	450		
	6	5	310		8	3	400		4	2	500		8	8	400		
	8	2	310		4	4	400	4	3	450	4		3	450			
	8	3	310		4	5	310	4	3	500	4		4	450			
	6	2	400		4	6	310	4	4	450	6		4	400			
	6	4	310		6	2	400	6	4	450	8		4	400			
	8	2	310		8	3	400	4	3	450	4		3	450			
	8	3	310		8	3	400	6	4	450	4		4	450			
				8	4	400	8	4	400	6	5	400					
								8	5	400							
								8	6	400							

Fan Data by Wheel Diameter and Type

FORWARD CURVE FANS										
Fan Wheel	Wheel Diameter (in.)	Inlet Cone Diameter (in.)	Max Speed (rpm)		Fan Shaft Diameter (in.)*		Fan Wheel Weight (lb)		Number of Fan Blades	K Factor
			Class 1	Class 2	Class 1	Class 2	Class 1	Class 2		
A9-4A	9-1/2	7-13/16	2132	2749	3/4	3/4	4	4	43	†
A10-8A	10-5/8	8-13/16	1806	2347	3/4	1	6	6	48	†
A12-11A	12-5/8	10-3/8	1533	1986	1	1-3/16	10	10	43	†
A12-12A	12-5/8	10-3/8	1491	1938	1	1-3/16	10	10	43	†
A15-15A	15	12-5/8	1262	1639	1-3/16	1-3/16	16	17	51	†
A18-18A	18-1/32	15-1/2	1097	1378	1-3/16	1-7/16	32	34	48	†
A20-15A	20	16-1/4	969	1238	1-7/16	1-11/16	51	51	37	†
A20-18A	20	16-1/4	960	1217	1-7/16	1-11/16	53	53	37	†
A20-18H	20	16-1/4	952	1237	1-3/16	1-7/16	42	45	51	†
A20-20H	20	16-1/4	952	1237	1-3/16	1-7/16	42	45	51	†
A22-22H	22-3/8	18-1/16	884	1119	1-7/16	2-3/16	63	63	37	†
A25-20H	25	21-5/16	770	980	1-11/16	2-7/16	73	73	37	†
A25-25H	25	21-5/16	751	960	1-11/16	2-7/16	81	81	37	†
A27-22H	27-5/8	23-15/16	684	873	1-11/16	2-7/16	101	101	37	†
A27-27H	27-5/8	23-15/16	656	865	1-11/16	2-7/16	111	111	37	†
A30-30H	30-1/4	26-3/8	618	793	1-11/16	2-11/16	128	128	37	†
32	31-1/2	25-3/4	675	760	2-3/16	2-3/16	132	134	38	23,750
36	35-7/16	29	600	660	2-7/16	2-7/16	158	178	42	31,300
40	39	32-3/4	550	600	2-7/16	2-7/16	194	214	48	37,650

AIRFOIL FANS										
Fan Wheel	Wheel Diameter (in.)	Inlet Cone Diameter (in.)	Max Speed (rpm)		Fan Shaft Diameter (in.)*		Fan Wheel Weight (lb)		Number of Fan Blades	K Factor
			Class 1	Class 2	Class 1	Class 2	Class 1	Class 2		
101	10	6-1/8	N/A	4655	N/A	1	N/A	8	18	631
121	12-1/4	7-1/2	N/A	4560	N/A	1-3/16	N/A	11	18	890
131	13-1/2	8-3/8	N/A	4033	N/A	1-7/16	N/A	15	18	1,098
161	16-1/2	10-1/8	N/A	3254	N/A	1-11/16	N/A	37	18	1,560
181	18-1/4	11	2261	2950	1-11/16	1-15/16	52	52	20	1,816
201	20	12-7/16	2019	2598	1-11/16	1-15/16	60	60	20	2,279
221	22-1/4	13-7/8	1872	2442	1-15/16	2-3/16	73	73	20	2,798
241	24-1/2	15-1/8	1701	2218	2-3/16	2-7/16	88	91	20	3,286
271	27	16-13/16	1463	1910	2-3/16	2-7/16	104	106	20	3,992
301	30	18-13/16	1316	1715	2-7/16	2-11/16	136	145	20	4,961
331	33	20-9/16	1202	1568	2-7/16	2-15/16	168	176	20	5,895
361	36-1/2	23-1/8	1055	1378	2-11/16	2-15/16	235	233	18	7,277
32	31-7/8	21-5/8	1300	1700	2-3/16	2-7/16	195	195	10	14,035
36	35-13/16	24	1250	1550	2-7/16	2-3/4	262	273	10	18,400
40	39-3/8	26-7/8	1200	1350	2-3/4	2-15/16	348	358	10	22,750
44	44-3/32	30	850	1150	2-15/16	3-3/16	441	459	10	28,650

* Minimum motor shaft diameter listed.

† Calculate from air balance data.

Fan Data by Wheel Diameter and Type (cont)

DIRECT DRIVE PLENUM FANS ASSEMBLIES WITH ELECTRONICALLY COMMUTATED MOTORS									
FAN MANUFACTURER	FAN WHEEL	BLADE DIA. (in.)	INLET CONE MIN. DIA.(in.)	FAN CLASS	MAX SPEED (rpm)	ASSEMBLY WEIGHT (lb)	# OF FAN BLADES	K FACTOR	K FACTOR W/ INLET GUARD
EBM	310	12.2	8.33	2	3955	46.3	5	1078	1043
	310	12.2	8.33	2	3975	46.3	5	1078	1043
	400	15.7	9.41	3	3700	80.0	6	1746	1698
	400	15.7	9.41	3	3700	80.0	6	1746	1698
	400	15.7	9.41	2	2800	66.0	5	1746	1698
	400	15.7	9.41	2	2800	66.0	5	1746	1698
	450	17.7	11.94	2	2290	81.4	5	2229	2156
	450	17.7	11.94	2	2440	81.4	5	2229	2156
	450	17.7	11.94	2	2810	103.6	5	2229	2156
	450	17.7	11.94	2	2610	103.6	5	2229	2156
	500	19.7	13.28	2	2410	111.1	5	2610	2519
	500	19.7	13.28	2	2372	108.7	5	2610	2519
ZA	310	12.2	7.60	2	3550	35.3	7	882	845
	310	12.2	7.60	2	3380	35.3	7	882	845
	310	12.2	7.60	1	3000	35.3	7	882	845
	310	12.2	7.60	2	4240	41.9	7	882	845
	350	13.8	8.58	2	3000	37.5	7	1124	1078
	350	13.8	8.58	1	2770	37.5	7	1124	1078
	400	15.7	9.69	2	2900	79.4	7	1431	1375
	400	15.7	9.69	1	2700	79.4	7	1431	1375
	400	15.7	9.69	2	3200	79.4	7	1431	1375
	400	15.7	9.69	2	3550	77.2	7	1431	1375
	450	17.7	10.94	1	2300	88.2	7	1830	1756
	450	17.7	10.84	2	2630	88.2	7	1830	1756
	500	19.7	12.28	2	2160	110.3	7	2341	2248
	560	22.0	13.66	1	1800	132.3	7	2861	2740

Fan Data by Wheel Diameter and Type (cont)

DIRECT DRIVE PLENUM FAN ASSEMBLIES WITH EC MOTORS, DIMENSIONS (in.)					
FAN MANUFACTURER	FAN WHEEL	MOTOR kW	ASSEMBLY HEIGHT	ASSEMBLY WIDTH	ASSEMBLY LENGTH
EBM	310	3.16	19.70	19.70	14.06
	310	3.13	19.70	19.70	14.06
	400	6.10	19.70	19.70	16.83
	400	6.40	19.70	19.70	16.83
	400	3.95	19.70	19.70	16.37
	400	3.97	19.70	19.70	16.37
	450	3.93	24.80	24.80	17.88
	450	4.41	24.80	24.80	17.88
	450	7.01	24.80	24.80	22.46
	450	5.72	24.80	24.80	22.46
	500	7.22	24.80	24.80	23.66
	500	7.20	24.80	24.80	23.66
	ZA	310	2.20	18.50	18.50
310		1.90	18.50	18.50	11.61
310		1.35	18.50	18.50	11.61
310		3.80	17.72	17.72	12.99
350		2.50	19.69	19.69	12.44
350		1.90	19.69	19.69	12.44
400		4.10	21.65	21.65	14.49
400		3.40	21.65	21.65	14.49
400		5.40	21.65	21.65	14.49
400		5.80	21.65	21.65	13.58
450		3.60	24.80	24.80	15.63
450		5.60	24.80	24.80	15.63
500		5.40	26.38	26.38	17.76
560		5.20	28.74	28.74	19.02

Direct-Expansion Circuiting Data — Medium Face Area Coils

39M UNIT SIZE	03W		06W			07T				08W			09T				10W			
	Quarter	Half	Quarter	Half	Full	Quarter	Half	Full	Double	Quarter	Half	Full	Quarter	Half	Full	Double	Quarter	Half	Full	
CIRCUITING TYPE	1,215		2,066			2,708				2,778			3,524				3,611			
Airflow (cfm) at 500 fpm	2.4		4.1			5.4				5.6			7.0				7.2			
Total Face Area (sq ft)	14	14	14	14	14	24	24	24	24	16	16	16	28	28	28	28	16	16	16	
 Tubes in Face	20	20	34	34	34	26	26	26	26	40	40	40	29	29	29	29	52	52	52	
Tube Length (in.)	4	7	4	7	14	6	12	24	48	4	8	16	7	14	28	56	4	8	16	
No. of Circuits - Total																				
4-Row Coil																				
Face Split Coils																				
No. of TXVs	2	2	2	2	—	2	2	2	—	2	2	—	2	2	2	—	2	2	—	
Suction Connections (in. OD)	7/8	7/8	7/8	7/8	—	7/8	1-1/8	1-3/8	—	7/8	7/8	—	7/8	1-1/8	1-5/8	—	7/8	7/8	—	
Distributor Connections (in. OD)	7/8	7/8	7/8	7/8	—	7/8	7/8	1-3/8	—	7/8	7/8	—	7/8	7/8	1-3/8	—	7/8	7/8	—	
Distributor Nozzle Size*	G-1.5	G-2.5 / G-2	G-1.5	G-2.5 / G-2	—	G-2	G-4	C-12	—	G-1.5	G-2.5	—	G-2.5 / G-2	G-6	C-15	—	G-1.5	G-2.5	—	
Intertwined Row Split Coils																				
No. of TXVs	2	2	2	2	—	2	2	2	—	2	2	—	2	2	2	—	2	2	—	
Suction Connections (in. OD)	7/8	7/8	7/8	7/8	—	7/8	1-1/8	1-3/8	—	7/8	7/8	—	7/8	1-1/8	1-5/8	—	7/8	7/8	—	
Distributor Connections (in. OD)	7/8	7/8	7/8	7/8	—	7/8	7/8	1-3/8	—	7/8	7/8	—	7/8	7/8	1-3/8	—	7/8	7/8	—	
Distributor Nozzle Size*	G-1.5	G-2.5 / G-2	G-1.5	G-2.5 / G-2	—	G-2	G-4	C-12	—	G-1.5	G-2.5	—	G-2.5 / G-2	G-6	C-15	—	G-1.5	G-2.5	—	
Single Circuit Coils																				
No. of TXVs	1	1	1	1	—	1	1	—	—	1	1	—	1	1	—	—	1	1	—	
Suction Connections (in. OD)	7/8	1-1/8	7/8	1-1/8	—	1-1/8	1-3/8	—	—	7/8	1-1/8	—	1-1/8	1-5/8	—	—	7/8	1-1/8	—	
Distributor Connections (in. OD)	7/8	7/8	7/8	7/8	—	7/8	1-3/8	—	—	7/8	7/8	—	7/8	1-3/8	—	—	7/8	7/8	—	
Distributor Nozzle Size	G-2.5	G-6	G-2.5	G-6	—	G-4	C-12	—	—	G-2.5	G-8	—	G-6	C-15	—	—	G-2.5	G-8	—	
6-Row Coil																				
Face Split Coils																				
No. of TXVs	2	2	2	2	—	—	2	2	—	2	2	—	—	2	2	—	2	2	—	
Suction Connections (in. OD)	7/8	7/8	7/8	7/8	—	—	1-1/8	1-3/8	—	7/8	7/8	—	—	1-1/8	1-5/8	—	7/8	7/8	—	
Distributor Connections (in. OD)	7/8	7/8	7/8	7/8	—	—	7/8	1-3/8	—	7/8	7/8	—	—	7/8	1-3/8	—	7/8	7/8	—	
Distributor Nozzle Size*	G-1.5	G-2.5 / G-2	G-1.5	G-2.5 / G-2	—	—	G-4	C-12	—	G-1.5	G-2.5	—	—	G-6	C-15	—	G-1.5	G-2.5	—	
Intertwined Row Split Coils																				
No. of TXVs	2	2	2	2	—	—	2	2	—	2	2	—	—	2	2	—	2	2	—	
Suction Connections (in. OD)	7/8	7/8	7/8	7/8	—	—	1-1/8	1-3/8	—	7/8	7/8	—	—	1-1/8	1-5/8	—	7/8	7/8	—	
Distributor Connections (in. OD)	7/8	7/8	7/8	7/8	—	—	7/8	1-3/8	—	7/8	7/8	—	—	7/8	1-3/8	—	7/8	7/8	—	
Distributor Nozzle Size*	G-1.5	G-2.5 / G-2	G-1.5	G-2.5 / G-2	—	—	G-4	C-12	—	G-1.5	G-2.5	—	—	G-6	C-15	—	G-1.5	G-2.5	—	
Single Circuit Coils																				
No. of TXVs	1	1	1	1	—	—	1	—	—	1	1	—	—	1	—	—	1	1	—	
Suction Connections (in. OD)	7/8	1-1/8	7/8	1-1/8	—	—	1-3/8	—	—	7/8	1-1/8	—	—	1-5/8	—	—	7/8	1-1/8	—	
Distributor Connections (in. OD)	7/8	7/8	7/8	7/8	—	—	1-3/8	—	—	7/8	7/8	—	—	1-3/8	—	—	7/8	7/8	—	
Distributor Nozzle Size	G-2.5	G-6	G-2.5	G-6	—	—	C-12	—	—	G-2.5	G-8	—	—	C-15	—	—	G-2.5	G-8	—	
8-Row Coil																				
Face Split Coils																				
No. of TXVs	—	2	—	2	2	—	2	2	4	—	2	2	—	2	2	4	—	2	2	
Suction Connections (in. OD)	—	7/8	—	7/8	1-1/8	—	1-1/8	1-3/8	1-3/8	—	7/8	1-1/8	—	1-1/8	1-5/8	1-5/8	—	7/8	1-1/8	
Distributor Connections (in. OD)	—	7/8	—	7/8	7/8	—	7/8	1-3/8	1-3/8	—	7/8	7/8	—	7/8	1-3/8	1-3/8	—	7/8	7/8	
Distributor Nozzle Size*	—	G-2.5 / G-2	—	G-2.5 / G-2	G-6	—	G-4	C-12	C-12	—	G-2.5	G-8	—	G-6	C-15	C-15	—	G-2.5	G-8	
Intertwined Row Split Coils																				
No. of TXVs	—	2	—	2	2	—	2	2	4	—	2	2	—	2	2	4	—	2	2	
Suction Connections (in. OD)	—	7/8	—	7/8	1-1/8	—	1-1/8	1-3/8	1-3/8	—	7/8	1-1/8	—	1-1/8	1-5/8	1-5/8	—	7/8	1-1/8	
Distributor Connections (in. OD)	—	7/8	—	7/8	7/8	—	7/8	1-3/8	1-3/8	—	7/8	7/8	—	7/8	1-3/8	1-3/8	—	7/8	7/8	
Distributor Nozzle Size*	—	G-2.5 / G-2	—	G-2.5 / G-2	G-6	—	G-4	C-12	C-12	—	G-2.5	G-8	—	G-6	C-15	C-15	—	G-2.5	G-8	
Single Circuit Coils																				
No. of TXVs	1	1	—	1	—	—	1	—	—	—	1	—	—	1	—	—	—	1	—	
Suction Connections (in. OD)	7/8	1-1/8	—	1-1/8	—	—	1-3/8	—	—	—	1-1/8	—	—	1-5/8	—	—	—	1-1/8	—	
Distributor Connections (in. OD)	7/8	7/8	—	7/8	—	—	1-3/8	—	—	—	7/8	—	—	1-3/8	—	—	—	7/8	—	
Distributor Nozzle Size	G-2.5	G-6	—	G-6	—	—	C-12	—	—	—	G-8	—	—	C-15	—	—	—	G-8	—	

LEGEND

TXV — Thermostatic Expansion Valve (Field Supplied)

*When 2 nozzle sizes are listed, the smaller nozzle should be located on the upper distributor.

NOTE: Factory-supplied distributors have factory-selected nozzle sizes as shown. If necessary, replace factory-supplied nozzles with field-supplied and field-installed nozzles. Consult **AHUBuilder®** software selection program for correct nozzle selection.

Direct-Expansion Circuiting Data — Medium Face Area Coils (cont)

39M UNIT SIZE	11T			12W			12T			14W			16T		17W		18T	
	Half	Full	Double	Quarter	Half	Full	Half	Full	Double	Quarter	Half	Full	Half	Full	Half	Full	Half	Full
CIRCUITING TYPE	4,444			4,965			4,861			6,146			5,938		6,771		7,474	
Airflow (cfm) at 500 fpm	8.9			9.9			9.7			12.3			11.9		13.5		14.9	
Total Face Area (sq ft)	32	32	32	22	22	22	32	32	32	24	24	24	36	36	24	24	42	42
Tube Length (in.)	32	32	32	52	52	52	35	35	35	59	59	59	38	38	65	65	41	41
No. of Circuits - Total	16	32	64	6	11	22	16	32	64	6	12	24	18	36	12	24	21	42
4-Row Coil																		
Face Split Coils																		
No. of TXVs	2	2	—	2	2	2	2	2	—	2	2	2	2	2	2	2	2	4
Suction Connections (in. OD)	1-1/8	1-5/8	—	7/8	1-1/8	1-3/8	1-1/8	1-5/8	—	7/8	1-1/8	1-3/8	1-3/8	1-5/8	1-1/8	1-3/8	1-3/8	1-3/8
Distributor Connections (in. OD)	7/8	1-3/8	—	7/8	7/8	1-1/8	7/8	1-3/8	—	7/8	7/8	1-3/8	1-1/8	1-3/8	7/8	1-3/8	1-1/8	1-1/8
Distributor Nozzle Size*	G-8	C-17	—	G-2	G-4 / G-3	E-12	G-8	C-17	—	G-2	G-4	C-12	E-8	C-17	G-4	C-12	E-12 / E-10	E-12 / E-10
Intertwined Row Split Coils																		
No. of TXVs	2	2	—	2	2	2	2	2	—	2	2	2	2	2	2	2	2	4
Suction Connections (in. OD)	1-1/8	1-5/8	—	7/8	1-1/8	1-3/8	1-1/8	1-5/8	—	7/8	1-1/8	1-3/8	1-3/8	1-5/8	1-1/8	1-3/8	1-3/8	1-3/8
Distributor Connections (in. OD)	7/8	1-3/8	—	7/8	7/8	1-1/8	7/8	1-3/8	—	7/8	7/8	1-3/8	1-1/8	1-3/8	7/8	1-3/8	1-1/8	1-1/8
Distributor Nozzle Size*	G-8	C-17	—	G-2	G-4 / G-3	E-12	G-8	C-17	—	G-2	G-4	C-12	E-8	C-17	G-4	C-12	E-12 / E-10	E-12 / E-10
Single Circuit Coils																		
No. of TXVs	—	—	—	1	1	—	—	—	—	1	1	—	—	—	1	—	—	—
Suction Connections (in. OD)	—	—	—	1-1/8	1-3/8	—	—	—	—	1-1/8	1-3/8	—	—	—	1-3/8	—	—	—
Distributor Connections (in. OD)	—	—	—	7/8	1-1/8	—	—	—	—	7/8	1-3/8	—	—	—	1-3/8	—	—	—
Distributor Nozzle Size	—	—	—	G-4	E-12	—	—	—	—	G-4	C-12	—	—	—	C-12	—	—	—
6-Row Coil																		
Face Split Coils																		
No. of TXVs	2	2	—	2	2	2	2	2	—	—	2	2	2	2	2	2	2	4
Suction Connections (in. OD)	1-1/8	1-5/8	—	7/8	1-1/8	1-3/8	1-1/8	1-5/8	—	—	1-1/8	1-3/8	1-3/8	1-5/8	1-1/8	1-3/8	1-3/8	1-3/8
Distributor Connections (in. OD)	7/8	1-3/8	—	7/8	7/8	1-1/8	7/8	1-3/8	—	—	7/8	1-3/8	1-1/8	1-3/8	7/8	1-3/8	1-1/8	1-1/8
Distributor Nozzle Size*	G-8	C-17	—	G-2	G-4 / G-3	E-12	G-8	C-17	—	—	G-4	C-12	E-8	C-17	G-4	C-12	E-12 / E-10	E-12 / E-10
Intertwined Row Split Coils																		
No. of TXVs	2	2	—	2	2	2	2	2	—	—	2	2	2	2	2	2	2	4
Suction Connections (in. OD)	1-1/8	1-5/8	—	7/8	1-1/8	1-3/8	1-1/8	1-5/8	—	—	1-1/8	1-3/8	1-3/8	1-5/8	1-1/8	1-3/8	1-3/8	1-3/8
Distributor Connections (in. OD)	7/8	1-3/8	—	7/8	7/8	1-1/8	7/8	1-3/8	—	—	7/8	1-3/8	1-1/8	1-3/8	7/8	1-3/8	1-1/8	1-1/8
Distributor Nozzle Size*	G-8	C-17	—	G-2	G-4 / G-3	E-12	G-8	C-17	—	—	G-4	C-12	E-8	C-17	G-4	C-12	E-12 / E-10	E-12 / E-10
Single Circuit Coils																		
No. of TXVs	—	—	—	1	1	—	—	—	—	—	1	—	—	—	1	—	—	—
Suction Connections (in. OD)	—	—	—	1-1/8	1-3/8	—	—	—	—	—	1-3/8	—	—	—	1-3/8	—	—	—
Distributor Connections (in. OD)	—	—	—	7/8	1-1/8	—	—	—	—	—	1-3/8	—	—	—	1-3/8	—	—	—
Distributor Nozzle Size	—	—	—	G-4	E-12	—	—	—	—	—	C-12	—	—	—	C-12	—	—	—
8-Row Coil																		
Face Split Coils																		
No. of TXVs	2	2	4	—	2	2	2	2	4	—	2	2	2	2	2	2	2	4
Suction Connections (in. OD)	1-1/8	1-5/8	1-5/8	—	1-1/8	1-3/8	1-1/8	1-5/8	1-5/8	—	1-1/8	1-3/8	1-3/8	1-5/8	1-1/8	1-3/8	1-3/8	1-3/8
Distributor Connections (in. OD)	7/8	1-3/8	1-3/8	—	7/8	1-1/8	7/8	1-3/8	1-3/8	—	7/8	1-3/8	1-1/8	1-3/8	7/8	1-3/8	1-1/8	1-1/8
Distributor Nozzle Size*	G-8	C-17	C-17	—	G-4 / G-3	E-12	G-8	C-17	C-17	—	G-4	C-12	E-8	C-17	G-4	C-12	E-12 / E-10	E-12 / E-10
Intertwined Row Split Coils																		
No. of TXVs	2	2	4	—	2	2	2	2	4	—	2	2	2	2	2	2	2	4
Suction Connections (in. OD)	1-1/8	1-5/8	1-5/8	—	1-1/8	1-3/8	1-1/8	1-5/8	1-5/8	—	1-1/8	1-3/8	1-3/8	1-5/8	1-1/8	1-3/8	1-3/8	1-3/8
Distributor Connections (in. OD)	7/8	1-3/8	1-3/8	—	7/8	1-1/8	7/8	1-3/8	1-3/8	—	7/8	1-3/8	1-1/8	1-3/8	7/8	1-3/8	1-1/8	1-1/8
Distributor Nozzle Size*	G-8	C-17	C-17	—	G-4 / G-3	E-12	G-8	C-17	C-17	—	G-4	C-12	E-8	C-17	G-4	C-12	E-12 / E-10	E-12 / E-10
Single Circuit Coils																		
No. of TXVs	—	—	—	—	1	—	—	—	—	—	1	—	—	—	1	—	—	—
Suction Connections (in. OD)	—	—	—	—	1-3/8	—	—	—	—	—	1-3/8	—	—	—	1-3/8	—	—	—
Distributor Connections (in. OD)	—	—	—	—	1-1/8	—	—	—	—	—	1-3/8	—	—	—	1-3/8	—	—	—
Distributor Nozzle Size	—	—	—	—	E-12	—	—	—	—	—	C-12	—	—	—	C-12	—	—	—

LEGEND

TXV — Thermostatic Expansion Valve (Field Supplied)

*When 2 nozzle sizes are listed, the smaller nozzle should be located on the upper distributor.

NOTE: Factory-supplied distributors have factory-selected nozzle sizes as shown. If necessary, replace factory-supplied nozzles with field-supplied and field-installed nozzles. Consult **AHUBuilder®** software selection program for correct nozzle selection.

Direct-Expansion Circuiting Data — Medium Face Area Coils (cont)

39M UNIT SIZE	21W			22T			25W			25T			30W		
	Half	Full	Double	Half	Full	Double	Half	Full	Double	Half	Full	Double	Half	Full	Double
CIRCUITING TYPE															
Airflow (cfm) at 500 fpm	9,028			8,976			10,278			9,358			12,778		
Total Face Area (sq ft)	18.1			18.0			20.6			18.7			25.6		
Tubes in Face	32	32	32	44	44	44	32	32	32	44	44	44	32	32	32
Tube Length (in.)	65	65	65	47	47	47	74	74	74	49	49	49	92	92	92
No. of Circuits - Total	16	32	64	22	44	88	16	32	64	22	44	88	16	32	64
4-Row Coil															
Face Split Coils															
No. of TXVs	2	2	—	2	4	—	2	2	—	2	4	—	2	2	—
Suction Connections (in. OD)	1-1/8	1-5/8	—	1-3/8	1-3/8	—	1-1/8	1-5/8	—	1-3/8	1-3/8	—	1-1/8	1-5/8	—
Distributor Connections (in. OD)	7/8	1-3/8	—	1-1/8	1-1/8	—	7/8	1-3/8	—	1-1/8	1-1/8	—	7/8	1-3/8	—
Distributor Nozzle Size	G-8	C-17	—	E-12	E-12	—	G-8	C-17	—	E-12	E-12	—	G-8	C-17	—
Intertwined Row Split Coils															
No. of TXVs	2	2	—	2	4	—	2	2	—	2	4	—	2	2	—
Suction Connections (in. OD)	1-1/8	1-5/8	—	1-3/8	1-3/8	—	1-1/8	1-5/8	—	1-3/8	1-3/8	—	1-1/8	1-5/8	—
Distributor Connections (in. OD)	7/8	1-3/8	—	1-1/8	1-1/8	—	7/8	1-3/8	—	1-1/8	1-1/8	—	7/8	1-3/8	—
Distributor Nozzle Size	G-8	C-17	—	E-12	E-12	—	G-8	C-17	—	E-12	E-12	—	G-8	C-17	—
Single Circuit Coils															
No. of TXVs	—	—	—	—	—	—	—	—	—	—	—	—	—	—	—
Suction Connections (in. OD)	—	—	—	—	—	—	—	—	—	—	—	—	—	—	—
Distributor Connections (in. OD)	—	—	—	—	—	—	—	—	—	—	—	—	—	—	—
Distributor Nozzle Size	—	—	—	—	—	—	—	—	—	—	—	—	—	—	—
6-Row Coil															
Face Split Coils															
No. of TXVs	2	2	—	2	4	—	2	2	—	2	4	—	2	2	—
Suction Connections (in. OD)	1-1/8	1-5/8	—	1-3/8	1-3/8	—	1-1/8	1-5/8	—	1-3/8	1-3/8	—	1-1/8	1-5/8	—
Distributor Connections (in. OD)	7/8	1-3/8	—	1-1/8	1-1/8	—	7/8	1-3/8	—	1-1/8	1-1/8	—	7/8	1-3/8	—
Distributor Nozzle Size	G-8	C-17	—	E-12	E-12	—	G-8	C-17	—	E-12	E-12	—	G-8	C-17	—
Intertwined Row Split Coils															
No. of TXVs	2	2	—	2	4	—	2	2	—	2	4	—	2	2	—
Suction Connections (in. OD)	1-1/8	1-5/8	—	1-3/8	1-3/8	—	1-1/8	1-5/8	—	1-3/8	1-3/8	—	1-1/8	1-5/8	—
Distributor Connections (in. OD)	7/8	1-3/8	—	1-1/8	1-1/8	—	7/8	1-3/8	—	1-1/8	1-1/8	—	7/8	1-3/8	—
Distributor Nozzle Size	G-8	C-17	—	E-12	E-12	—	G-8	C-17	—	E-12	E-12	—	G-8	C-17	—
Single Circuit Coils															
No. of TXVs	—	—	—	—	—	—	—	—	—	—	—	—	—	—	—
Suction Connections (in. OD)	—	—	—	—	—	—	—	—	—	—	—	—	—	—	—
Distributor Connections (in. OD)	—	—	—	—	—	—	—	—	—	—	—	—	—	—	—
Distributor Nozzle Size	—	—	—	—	—	—	—	—	—	—	—	—	—	—	—
8-Row Coil															
Face Split Coils															
No. of TXVs	2	2	4	2	4	8	2	2	4	2	4	8	2	2	4
Suction Connections (in. OD)	1-1/8	1-5/8	1-5/8	1-3/8	1-3/8	1-3/8	1-1/8	1-5/8	1-5/8	1-3/8	1-3/8	1-3/8	1-1/8	1-5/8	1-5/8
Distributor Connections (in. OD)	7/8	1-3/8	1-3/8	1-1/8	1-1/8	1-1/8	7/8	1-3/8	1-3/8	1-1/8	1-1/8	1-1/8	7/8	1-3/8	1-3/8
Distributor Nozzle Size	G-8	C-17	C-17	E-12	E-12	E-12	G-8	C-17	C-17	E-12	E-12	E-12	G-8	C-17	C-17
Intertwined Row Split Coils															
No. of TXVs	—	2	4	—	4	8	2	2	4	—	4	8	—	2	4
Suction Connections (in. OD)	—	1-5/8	1-5/8	—	1-3/8	1-3/8	1-1/8	1-5/8	1-5/8	—	1-3/8	1-3/8	—	1-5/8	1-5/8
Distributor Connections (in. OD)	—	1-3/8	1-3/8	—	1-1/8	1-1/8	7/8	1-3/8	1-3/8	—	1-1/8	1-1/8	—	1-3/8	1-3/8
Distributor Nozzle Size	—	C-17	C-17	—	E-12	E-12	G-8	C-17	C-17	—	E-12	E-12	—	C-17	C-17
Single Circuit Coils															
No. of TXVs	—	—	—	—	—	—	—	—	—	—	—	—	—	—	—
Suction Connections (in. OD)	—	—	—	—	—	—	—	—	—	—	—	—	—	—	—
Distributor Connections (in. OD)	—	—	—	—	—	—	—	—	—	—	—	—	—	—	—
Distributor Nozzle Size	—	—	—	—	—	—	—	—	—	—	—	—	—	—	—

LEGEND

TXV — Thermostatic Expansion Valve (Field Supplied)

*When 2 nozzle sizes are listed, the smaller nozzle should be located on the upper distributor.

NOTE: Factory-supplied distributors have factory-selected nozzle sizes as shown. If necessary, replace factory-supplied nozzles with field-supplied and field-installed nozzles. Consult **AHUBuilder®** software selection program for correct nozzle selection.

Direct-Expansion Circuiting Data — Medium Face Area Coils (cont)

39M UNIT SIZE	30T			35T				36W		37T				40W					
	Half	Full	Double	Half	Full	Double	Full	Double	Half	Full	Double	Full	Double	Full	Double				
CIRCUITING TYPE	11,267			13,958				15,000		15,365				18,333					
Airflow (cfm) at 500 fpm	22.5			27.9				30.0		30.7				36.7					
Total Face Area (sq ft)	44	44	44	24	24	24	24	24	24	36	36	30	30	30	30	30	30	44	44
Tubes in Face	59	59	59	67	67	67	67	67	67	96	96	59	59	59	59	59	59	96	96
Tube Length (in.)	22	44	88	12	12	24	24	48	48	36	72	15	15	30	30	60	60	44	88
No. of Circuits - Total				Upper	Lower	Upper	Lower	Upper	Lower			Upper	Lower	Upper	Lower	Upper	Lower		
4-Row Coil																			
Face Split Coils																			
No. of TXVs	2	4	—	2	2	2	2	—	—	2	—	2	2	2	2	—	—	4	—
Suction Connections (in. OD)	1-3/8	1-3/8	—	1-1/8	1-1/8	1-3/8	1-3/8	—	—	1-5/8	—	1-1/8	1-1/8	1-5/8	1-5/8	—	—	1-3/8	—
Distributor Connections (in. OD)	1-1/8	1-1/8	—	7/8	7/8	1-3/8	1-3/8	—	—	1-3/8	—	7/8	7/8	1-3/8	1-3/8	—	—	1-1/8	—
Distributor Nozzle Size*	E-12	E-12	—	G-4	G-4	C-12	C-12	—	—	C-17	—	G-8 / G-6	G-8 / G-6	C-15	C-15	—	—	E-12	—
Intertwined Row Split Coils																			
No. of TXVs	2	4	—	2	2	2	2	—	—	2	—	2	2	2	2	—	—	4	—
Suction Connections (in. OD)	1-3/8	1-3/8	—	1-1/8	1-1/8	1-3/8	1-3/8	—	—	1-5/8	—	1-1/8	1-1/8	1-5/8	1-5/8	—	—	1-3/8	—
Distributor Connections (in. OD)	1-1/8	1-1/8	—	7/8	7/8	1-3/8	1-3/8	—	—	1-3/8	—	7/8	7/8	1-3/8	1-3/8	—	—	1-1/8	—
Distributor Nozzle Size*	E-12	E-12	—	G-4	G-4	C-12	C-12	—	—	C-17	—	G-8 / G-6	G-8 / G-6	C-15	C-15	—	—	E-12	—
Single Circuit Coils																			
No. of TXVs	—	—	—	—	—	—	—	—	—	—	—	—	—	—	—	—	—	—	—
Suction Connections (in. OD)	—	—	—	—	—	—	—	—	—	—	—	—	—	—	—	—	—	—	—
Distributor Connections (in. OD)	—	—	—	—	—	—	—	—	—	—	—	—	—	—	—	—	—	—	—
Distributor Nozzle Size	—	—	—	—	—	—	—	—	—	—	—	—	—	—	—	—	—	—	—
6-Row Coil																			
Face Split Coils																			
No. of TXVs	2	4	—	2	2	2	2	—	—	2	—	2	2	2	2	—	—	4	—
Suction Connections (in. OD)	1-3/8	1-3/8	—	1-1/8	1-1/8	1-3/8	1-3/8	—	—	1-5/8	—	1-1/8	1-1/8	1-5/8	1-5/8	—	—	1-3/8	—
Distributor Connections (in. OD)	1-1/8	1-1/8	—	7/8	7/8	1-3/8	1-3/8	—	—	1-3/8	—	7/8	7/8	1-3/8	1-3/8	—	—	1-1/8	—
Distributor Nozzle Size*	E-12	E-12	—	G-4	G-4	C-12	C-12	—	—	C-17	—	G-8 / G-6	G-8 / G-6	C-15	C-15	—	—	E-12	—
Intertwined Row Split Coils																			
No. of TXVs	2	4	—	2	2	2	2	—	—	2	—	2	2	2	2	—	—	4	—
Suction Connections (in. OD)	1-3/8	1-3/8	—	1-1/8	1-1/8	1-3/8	1-3/8	—	—	1-5/8	—	1-1/8	1-1/8	1-5/8	1-5/8	—	—	1-3/8	—
Distributor Connections (in. OD)	1-1/8	1-1/8	—	7/8	7/8	1-3/8	1-3/8	—	—	1-3/8	—	7/8	7/8	1-3/8	1-3/8	—	—	1-1/8	—
Distributor Nozzle Size*	E-12	E-12	—	G-4	G-4	C-12	C-12	—	—	C-17	—	G-8 / G-6	G-8 / G-6	C-15	C-15	—	—	E-12	—
Single Circuit Coils																			
No. of TXVs	—	—	—	—	—	—	—	—	—	—	—	—	—	—	—	—	—	—	—
Suction Connections (in. OD)	—	—	—	—	—	—	—	—	—	—	—	—	—	—	—	—	—	—	—
Distributor Connections (in. OD)	—	—	—	—	—	—	—	—	—	—	—	—	—	—	—	—	—	—	—
Distributor Nozzle Size	—	—	—	—	—	—	—	—	—	—	—	—	—	—	—	—	—	—	—
8-Row Coil																			
Face Split Coils																			
No. of TXVs	2	4	8	2	2	2	2	4	4	2	4	2	2	2	2	4	4	4	8
Suction Connections (in. OD)	1-3/8	1-3/8	1-3/8	1-1/8	1-1/8	1-3/8	1-3/8	1-3/8	1-3/8	1-5/8	1-5/8	1-1/8	1-1/8	1-5/8	1-5/8	1-5/8	1-5/8	1-3/8	1-3/8
Distributor Connections (in. OD)	1-1/8	1-1/8	1-1/8	7/8	7/8	1-3/8	1-3/8	1-3/8	1-3/8	1-3/8	1-3/8	7/8	7/8	1-3/8	1-3/8	1-3/8	1-3/8	1-1/8	1-1/8
Distributor Nozzle Size*	E-12	E-12	E-12	G-4	G-4	C-12	C-12	C-12	C-12	C-17	C-17	G-8 / G-6	G-8 / G-6	C-15	C-15	C-15	C-15	E-12	E-12
Intertwined Row Split Coils																			
No. of TXVs	—	4	8	2	2	2	2	4	4	2	4	2	2	2	2	4	4	4	8
Suction Connections (in. OD)	—	1-3/8	1-3/8	1-1/8	1-1/8	1-3/8	1-3/8	1-3/8	1-3/8	1-5/8	1-5/8	1-1/8	1-1/8	1-5/8	1-5/8	1-5/8	1-5/8	1-3/8	1-3/8
Distributor Connections (in. OD)	—	1-1/8	1-1/8	7/8	7/8	1-3/8	1-3/8	1-3/8	1-3/8	1-3/8	1-3/8	7/8	7/8	1-3/8	1-3/8	1-3/8	1-3/8	1-1/8	1-1/8
Distributor Nozzle Size*	—	E-12	E-12	G-4	G-4	C-12	C-12	C-12	C-12	C-17	C-17	G-8 / G-6	G-8 / G-6	C-15	C-15	C-15	C-15	E-12	E-12
Single Circuit Coils																			
No. of TXVs	—	—	—	—	—	—	—	—	—	—	—	—	—	—	—	—	—	—	—
Suction Connections (in. OD)	—	—	—	—	—	—	—	—	—	—	—	—	—	—	—	—	—	—	—
Distributor Connections (in. OD)	—	—	—	—	—	—	—	—	—	—	—	—	—	—	—	—	—	—	—
Distributor Nozzle Size	—	—	—	—	—	—	—	—	—	—	—	—	—	—	—	—	—	—	—

LEGEND

TXV — Thermostatic Expansion Valve (Field Supplied)

*When 2 nozzle sizes are listed, the smaller nozzle should be located on the upper distributor.

NOTE: Factory-supplied distributors have factory-selected nozzle sizes as shown. If necessary, replace factory-supplied nozzles with field-supplied and field-installed nozzles. Consult **AHUBuilder®** software selection program for correct nozzle selection.

Direct-Expansion Circuiting Data — Medium Face Area Coils (cont)

39M UNIT SIZE	42T						50W				51T						58T					
CIRCUITING TYPE	Half			Full			Double		Full	Double	Half		Full		Double		Half		Full		Double	
Airflow (cfm) at 500 fpm	17,448						19,861				21,094						23,906					
Total Face Area (sq ft)	34.9						39.7				42.2						47.8					
Tubes in Face	30	30	30	30	30	30	44	44	81	30	30	30	30	30	30	34	34	34	34	34	34	
Tube Length (in.)	67	67	67	67	67	67	104	104	81	81	81	81	81	81	81	81	81	81	81	81	81	
No. of Circuits - Total	15	15	30	30	60	60	44	88	15	15	30	30	60	60	17	17	34	34	68	68	68	
4-Row Coil	Upper	Lower	Upper	Lower	Upper	Lower			Upper	Lower	Upper	Lower	Upper	Lower	Upper	Lower	Upper	Lower	Upper	Lower	Upper	Lower
Face Split Coils																						
No. of TXVs	2	2	2	2	—	—	4	—	2	2	2	2	—	—	2	2	2	2	—	—		
Suction Connections (in. OD)	1-1/8	1-1/8	1-5/8	1-5/8	—	—	1-3/8	—	1-1/8	1-1/8	1-5/8	1-5/8	—	—	1-3/8	1-3/8	1-5/8	1-5/8	—	—		
Distributor Connections (in. OD)	7/8	7/8	1-3/8	1-3/8	—	—	1-1/8	—	7/8	7/8	1-3/8	1-3/8	—	—	1-1/8	1-1/8	1-3/8	1-3/8	—	—		
Distributor Nozzle Size*	G-8/ G-6	G-8/ G-6	C-15	C-15	—	—	E-12	—	G-8/ G-6	G-8/ G-6	C-15	C-15	—	—	E-8	E-8	C-17	C-17	—	—		
Intertwined Row Split Coils																						
No. of TXVs	2	2	2	2	—	—	4	—	2	2	2	2	—	—	2	2	2	2	—	—		
Suction Connections (in. OD)	1-1/8	1-1/8	1-5/8	1-5/8	—	—	1-3/8	—	1-1/8	1-1/8	1-5/8	1-5/8	—	—	1-3/8	1-3/8	1-5/8	1-5/8	—	—		
Distributor Connections (in. OD)	7/8	7/8	1-3/8	1-3/8	—	—	1-1/8	—	7/8	7/8	1-3/8	1-3/8	—	—	1-1/8	1-1/8	1-3/8	1-3/8	—	—		
Distributor Nozzle Size*	G-8/ G-6	G-8/ G-6	C-15	C-15	—	—	E-12	—	G-8/ G-6	G-8/ G-6	C-15	C-15	—	—	E-8	E-8	C-17	C-17	—	—		
Single Circuit Coils																						
No. of TXVs	—	—	—	—	—	—	—	—	—	—	—	—	—	—	—	—	—	—	—	—		
Suction Connections (in. OD)	—	—	—	—	—	—	—	—	—	—	—	—	—	—	—	—	—	—	—	—		
Distributor Connections (in. OD)	—	—	—	—	—	—	—	—	—	—	—	—	—	—	—	—	—	—	—	—		
Distributor Nozzle Size	—	—	—	—	—	—	—	—	—	—	—	—	—	—	—	—	—	—	—	—		
6-Row Coil																						
Face Split Coils																						
No. of TXVs	2	2	2	2	—	—	4	—	2	2	2	2	—	—	2	2	2	2	—	—		
Suction Connections (in. OD)	1-1/8	1-1/8	1-5/8	1-5/8	—	—	1-3/8	—	1-1/8	1-1/8	1-5/8	1-5/8	—	—	1-3/8	1-3/8	1-5/8	1-5/8	—	—		
Distributor Connections (in. OD)	7/8	7/8	1-3/8	1-3/8	—	—	1-1/8	—	7/8	7/8	1-3/8	1-3/8	—	—	1-1/8	1-1/8	1-3/8	1-3/8	—	—		
Distributor Nozzle Size*	G-8/ G-6	G-8/ G-6	C-15	C-15	—	—	E-12	—	G-8/ G-6	G-8/ G-6	C-15	C-15	—	—	E-8	E-8	C-17	C-17	—	—		
Intertwined Row Split Coils																						
No. of TXVs	2	2	2	2	—	—	4	—	2	2	2	2	—	—	2	2	2	2	—	—		
Suction Connections (in. OD)	1-1/8	1-1/8	1-5/8	1-5/8	—	—	1-3/8	—	1-1/8	1-1/8	1-5/8	1-5/8	—	—	1-3/8	1-3/8	1-5/8	1-5/8	—	—		
Distributor Connections (in. OD)	7/8	7/8	1-3/8	1-3/8	—	—	1-1/8	—	7/8	7/8	1-3/8	1-3/8	—	—	1-1/8	1-1/8	1-3/8	1-3/8	—	—		
Distributor Nozzle Size*	G-8/ G-6	G-8/ G-6	C-15	C-15	—	—	E-12	—	G-8/ G-6	G-8/ G-6	C-15	C-15	—	—	E-8	E-8	C-17	C-17	—	—		
Single Circuit Coils																						
No. of TXVs	—	—	—	—	—	—	—	—	—	—	—	—	—	—	—	—	—	—	—	—		
Suction Connections (in. OD)	—	—	—	—	—	—	—	—	—	—	—	—	—	—	—	—	—	—	—	—		
Distributor Connections (in. OD)	—	—	—	—	—	—	—	—	—	—	—	—	—	—	—	—	—	—	—	—		
Distributor Nozzle Size	—	—	—	—	—	—	—	—	—	—	—	—	—	—	—	—	—	—	—	—		
8-Row Coil																						
Face Split Coils																						
No. of TXVs	2	2	2	2	4	4	4	8	2	2	2	2	4	4	2	2	2	2	4	4		
Suction Connections (in. OD)	1-1/8	1-1/8	1-5/8	1-5/8	1-5/8	1-5/8	1-3/8	1-3/8	1-1/8	1-1/8	1-5/8	1-5/8	1-5/8	1-5/8	1-3/8	1-3/8	1-5/8	1-5/8	1-5/8	1-5/8		
Distributor Connections (in. OD)	7/8	7/8	1-3/8	1-3/8	1-3/8	1-3/8	1-1/8	1-1/8	7/8	7/8	1-3/8	1-3/8	1-3/8	1-3/8	1-1/8	1-1/8	1-3/8	1-3/8	1-3/8	1-3/8		
Distributor Nozzle Size*	G-8/ G-6	G-8/ G-6	C-15	C-15	C-15	C-15	E-12	E-12	G-8/ G-6	G-8/ G-6	C-15	C-15	C-15	C-15	E-8	E-8	C-17	C-17	C-17	C-17		
Intertwined Row Split Coils																						
No. of TXVs	2	2	2	2	4	4	4	8	2	2	2	2	4	4	2	2	2	2	4	4		
Suction Connections (in. OD)	1-1/8	1-1/8	1-5/8	1-5/8	1-5/8	1-5/8	1-3/8	1-3/8	1-1/8	1-1/8	1-5/8	1-5/8	1-5/8	1-5/8	1-3/8	1-3/8	1-5/8	1-5/8	1-5/8	1-5/8		
Distributor Connections (in. OD)	7/8	7/8	1-3/8	1-3/8	1-3/8	1-3/8	1-1/8	1-1/8	7/8	7/8	1-3/8	1-3/8	1-3/8	1-3/8	1-1/8	1-1/8	1-3/8	1-3/8	1-3/8	1-3/8		
Distributor Nozzle Size*	G-8/ G-6	G-8/ G-6	C-15	C-15	C-15	C-15	E-12	E-12	G-8/ G-6	G-8/ G-6	C-15	C-15	C-15	C-15	E-8	E-8	C-17	C-17	C-17	C-17		
Single Circuit Coils																						
No. of TXVs	—	—	—	—	—	—	—	—	—	—	—	—	—	—	—	—	—	—	—	—		
Suction Connections (in. OD)	—	—	—	—	—	—	—	—	—	—	—	—	—	—	—	—	—	—	—	—		
Distributor Connections (in. OD)	—	—	—	—	—	—	—	—	—	—	—	—	—	—	—	—	—	—	—	—		
Distributor Nozzle Size	—	—	—	—	—	—	—	—	—	—	—	—	—	—	—	—	—	—	—	—		

LEGEND

TXV — Thermostatic Expansion Valve (Field Supplied)

*When 2 nozzle sizes are listed, the smaller nozzle should be located on the upper distributor.

NOTE: Factory-supplied distributors have factory-selected nozzle sizes as shown. If necessary, replace factory-supplied nozzles with field-supplied and field-installed nozzles. Consult **AHUBuilder®** software selection program for correct nozzle selection.

Direct-Expansion Circuiting Data — Medium Face Area Coils (cont)

39M UNIT SIZE	61W				72W				85W				96W				110W			
CIRCUITING TYPE	Full		Double		Full		Double		Full		Double		Full		Double		Full		Double	
Airflow (cfm) at 500 fpm	25,278				29,722				35,000				39,375				45,000			
Total Face Area (sq ft)	50.6				59.4				70.0				78.8				90.0			
Tubes in Face	28	28	28	28	32	32	32	32	32	32	32	32	36	36	36	36	36	36	36	36
Tube Length (in.)	104	104	104	104	107	107	107	107	126	126	126	126	126	126	126	126	144	144	144	144
No. of Circuits - Total	28	28	56	56	32	32	64	64	32	32	64	64	36	36	72	72	36	36	72	72
4-Row Coil	Upper	Lower	Upper	Lower	Upper	Lower	Upper	Lower	Upper	Lower	Upper	Lower	Upper	Lower	Upper	Lower	Upper	Lower	Upper	Lower
Face Split Coils																				
No. of TXVs	2	2	—	—	2	2	—	—	2	2	—	—	2	2	—	—	2	2	—	—
Suction Connections (in. OD)	1-5/8	1-5/8	—	—	1-5/8	1-5/8	—	—	1-5/8	1-5/8	—	—	1-5/8	1-5/8	—	—	1-5/8	1-5/8	—	—
Distributor Connections (in. OD)	1-3/8	1-3/8	—	—	1-3/8	1-3/8	—	—	1-3/8	1-3/8	—	—	1-3/8	1-3/8	—	—	1-3/8	1-3/8	—	—
Distributor Nozzle Size	C-15	C-15	—	—	C-17	C-17	—	—	C-17	C-17	—	—	C-17	C-17	—	—	C-17	C-17	—	—
Intertwined Row Split Coils																				
No. of TXVs	2	2	—	—	2	2	—	—	2	2	—	—	2	2	—	—	2	2	—	—
Suction Connections (in. OD)	1-5/8	1-5/8	—	—	1-5/8	1-5/8	—	—	1-5/8	1-5/8	—	—	1-5/8	1-5/8	—	—	1-5/8	1-5/8	—	—
Distributor Connections (in. OD)	1-3/8	1-3/8	—	—	1-3/8	1-3/8	—	—	1-3/8	1-3/8	—	—	1-3/8	1-3/8	—	—	1-3/8	1-3/8	—	—
Distributor Nozzle Size	C-15	C-15	—	—	C-17	C-17	—	—	C-17	C-17	—	—	C-17	C-17	—	—	C-17	C-17	—	—
Single Circuit Coils																				
No. of TXVs	—	—	—	—	—	—	—	—	—	—	—	—	—	—	—	—	—	—	—	—
Suction Connections (in. OD)	—	—	—	—	—	—	—	—	—	—	—	—	—	—	—	—	—	—	—	—
Distributor Connections (in. OD)	—	—	—	—	—	—	—	—	—	—	—	—	—	—	—	—	—	—	—	—
Distributor Nozzle Size	—	—	—	—	—	—	—	—	—	—	—	—	—	—	—	—	—	—	—	—
6-Row Coil																				
Face Split Coils																				
No. of TXVs	2	2	—	—	2	2	—	—	2	2	—	—	2	2	—	—	2	2	—	—
Suction Connections (in. OD)	1-5/8	1-5/8	—	—	1-5/8	1-5/8	—	—	1-5/8	1-5/8	—	—	1-5/8	1-5/8	—	—	1-5/8	1-5/8	—	—
Distributor Connections (in. OD)	1-3/8	1-3/8	—	—	1-3/8	1-3/8	—	—	1-3/8	1-3/8	—	—	1-3/8	1-3/8	—	—	1-3/8	1-3/8	—	—
Distributor Nozzle Size	C-15	C-15	—	—	C-17	C-17	—	—	C-17	C-17	—	—	C-17	C-17	—	—	C-17	C-17	—	—
Intertwined Row Split Coils																				
No. of TXVs	2	2	—	—	2	2	—	—	2	2	—	—	2	2	—	—	2	2	—	—
Suction Connections (in. OD)	1-5/8	1-5/8	—	—	1-5/8	1-5/8	—	—	1-5/8	1-5/8	—	—	1-5/8	1-5/8	—	—	1-5/8	1-5/8	—	—
Distributor Connections (in. OD)	1-3/8	1-3/8	—	—	1-3/8	1-3/8	—	—	1-3/8	1-3/8	—	—	1-3/8	1-3/8	—	—	1-3/8	1-3/8	—	—
Distributor Nozzle Size	C-15	C-15	—	—	C-17	C-17	—	—	C-17	C-17	—	—	C-17	C-17	—	—	C-17	C-17	—	—
Single Circuit Coils																				
No. of TXVs	—	—	—	—	—	—	—	—	—	—	—	—	—	—	—	—	—	—	—	—
Suction Connections (in. OD)	—	—	—	—	—	—	—	—	—	—	—	—	—	—	—	—	—	—	—	—
Distributor Connections (in. OD)	—	—	—	—	—	—	—	—	—	—	—	—	—	—	—	—	—	—	—	—
Distributor Nozzle Size	—	—	—	—	—	—	—	—	—	—	—	—	—	—	—	—	—	—	—	—
8-Row Coil																				
Face Split Coils																				
No. of TXVs	2	2	4	4	2	2	4	4	2	2	4	4	2	2	4	4	2	2	4	4
Suction Connections (in. OD)	1-5/8	1-5/8	1-5/8	1-5/8	1-5/8	1-5/8	1-5/8	1-5/8	1-5/8	1-5/8	1-5/8	1-5/8	1-5/8	1-5/8	1-5/8	1-5/8	1-5/8	1-5/8	1-5/8	1-5/8
Distributor Connections (in. OD)	1-3/8	1-3/8	1-3/8	1-3/8	1-3/8	1-3/8	1-3/8	1-3/8	1-3/8	1-3/8	1-3/8	1-3/8	1-3/8	1-3/8	1-3/8	1-3/8	1-3/8	1-3/8	1-3/8	1-3/8
Distributor Nozzle Size	C-15	C-15	C-15	C-15	C-17	C-17	C-17	C-17	C-17	C-17	C-17	C-17	C-17	C-17	C-17	C-17	C-17	C-17	C-17	C-17
Intertwined Row Split Coils																				
No. of TXVs	2	2	4	4	2	2	4	4	2	2	4	4	2	2	4	4	2	2	4	4
Suction Connections (in. OD)	1-5/8	1-5/8	1-5/8	1-5/8	1-5/8	1-5/8	1-5/8	1-5/8	1-5/8	1-5/8	1-5/8	1-5/8	1-5/8	1-5/8	1-5/8	1-5/8	1-5/8	1-5/8	1-5/8	1-5/8
Distributor Connections (in. OD)	1-3/8	1-3/8	1-3/8	1-3/8	1-3/8	1-3/8	1-3/8	1-3/8	1-3/8	1-3/8	1-3/8	1-3/8	1-3/8	1-3/8	1-3/8	1-3/8	1-3/8	1-3/8	1-3/8	1-3/8
Distributor Nozzle Size	C-15	C-15	C-15	C-15	C-17	C-17	C-17	C-17	C-17	C-17	C-17	C-17	C-17	C-17	C-17	C-17	C-17	C-17	C-17	C-17
Single Circuit Coils																				
No. of TXVs	—	—	—	—	—	—	—	—	—	—	—	—	—	—	—	—	—	—	—	—
Suction Connections (in. OD)	—	—	—	—	—	—	—	—	—	—	—	—	—	—	—	—	—	—	—	—
Distributor Connections (in. OD)	—	—	—	—	—	—	—	—	—	—	—	—	—	—	—	—	—	—	—	—
Distributor Nozzle Size	—	—	—	—	—	—	—	—	—	—	—	—	—	—	—	—	—	—	—	—

LEGEND

TXV — Thermostatic Expansion Valve (Field Supplied)

*When 2 nozzle sizes are listed, the smaller nozzle should be located on the upper distributor.

NOTE: Factory-supplied distributors have factory-selected nozzle sizes as shown. If necessary, replace factory-supplied nozzles with field-supplied and field-installed nozzles. Consult **AHUBuilder®** software selection program for correct nozzle selection.

Direct-Expansion Circuiting Data — Large Face Area Coils

39M UNIT SIZE	03W		06W			07T				08W			09T			
	Quarter	Half	Quarter	Half	Full	Quarter	Half	Full	Double	Quarter	Half	Full	Quarter	Half	Full	Double
CIRCUITING TYPE	1,736		2,951			3,837				3,819			4,531			
Airflow (cfm) at 500 fpm	3.5		5.9			7.7				7.6			9.1			
Total Face Area (sq ft)	20	20	20	20	20	34	34	34	34	22	22	22	36	36	36	36
Tubes in Face	20	20	34	34	34	26	26	26	26	40	40	40	29	29	29	29
Tube Length (in.)	4	10	4	10	20	9	17	34	68	6	11	22	9	18	36	72
No. of Circuits - Total																
4-Row Coil																
Face Split Coils																
No. of TXVs	2	2	2	2	—	2	2	2	—	2	2	—	2	2	2	—
Suction Connections (in. OD)	7/8	1-1/8	7/8	1-1/8	—	1-1/8	1-3/8	1-5/8	—	7/8	1-1/8	—	1-1/8	1-3/8	1-5/8	—
Distributor Connections (in. OD)	7/8	7/8	7/8	7/8	—	7/8	1-1/8	1-3/8	—	7/8	7/8	—	7/8	1-1/8	1-3/8	—
Distributor Nozzle Size*	G-1.5	G-3	G-1.5	G-3	—	G-3 / G-2.5	E-8	C-17	—	G-2	G-4 / G-3	—	G-3 / G-2	E-8	C-17	—
Intertwined Row Split Coils																
No. of TXVs	2	2	2	2	—	2	2	2	—	2	2	—	2	2	2	—
Suction Connections (in. OD)	7/8	1-1/8	7/8	1-1/8	—	1-1/8	1-3/8	1-5/8	—	7/8	1-1/8	—	1-1/8	1-3/8	1-5/8	—
Distributor Connections (in. OD)	7/8	7/8	7/8	7/8	—	7/8	1-1/8	1-3/8	—	7/8	7/8	—	7/8	1-1/8	1-3/8	—
Distributor Nozzle Size*	G-1.5	G-3	G-1.5	G-3	—	G-3 / G-2.5	E-8	C-17	—	G-2	G-4 / G-3	—	G-3 / G-2.5	E-8	C-17	—
Single Circuit Coils																
No. of TXVs	1	1	1	1	—	1	—	—	—	1	1	—	1	—	—	—
Suction Connections (in. OD)	1-1/8	1-3/8	1-1/8	1-3/8	—	1-3/8	—	—	—	1-1/8	1-3/8	—	1-3/8	—	—	—
Distributor Connections (in. OD)	7/8	1-1/8	7/8	1-1/8	—	1-1/8	—	—	—	7/8	1-1/8	—	1-1/8	—	—	—
Distributor Nozzle Size	G-3	E-10	G-3	E-10	—	E-8	—	—	—	G-4	E-12	—	E-8	—	—	—
6-Row Coil																
Face Split Coils																
No. of TXVs	2	2	2	2	—	—	2	2	—	2	2	2	—	2	2	—
Suction Connections (in. OD)	7/8	1-1/8	7/8	1-1/8	—	—	1-3/8	1-5/8	—	7/8	1-1/8	1-3/8	—	1-3/8	1-5/8	—
Distributor Connections (in. OD)	7/8	7/8	7/8	7/8	—	—	1-1/8	1-3/8	—	7/8	7/8	—	1-1/8	1-3/8	1-5/8	—
Distributor Nozzle Size*	G-1.5	G-3	G-1.5	G-3	—	—	E-8	C-17	—	G-2	G-4 / G-3	E-12	—	E-8	C-17	—
Intertwined Row Split Coils																
No. of TXVs	2	2	2	2	—	—	2	2	—	2	2	2	—	2	2	—
Suction Connections (in. OD)	7/8	1-1/8	7/8	1-1/8	—	—	1-3/8	1-5/8	—	7/8	1-1/8	1-3/8	—	1-3/8	1-5/8	—
Distributor Connections (in. OD)	7/8	7/8	7/8	7/8	—	—	1-1/8	1-3/8	—	7/8	7/8	1-1/8	—	1-1/8	1-3/8	—
Distributor Nozzle Size*	G-1.5	G-3	G-1.5	G-3	—	—	E-8	C-17	—	G-2	G-4 / G-3	E-12	—	E-8	C-17	—
Single Circuit Coils																
No. of TXVs	1	1	1	1	—	—	—	—	—	1	1	—	—	—	—	—
Suction Connections (in. OD)	1-1/8	1-3/8	1-1/8	1-3/8	—	—	—	—	—	1-1/8	1-3/8	—	—	—	—	—
Distributor Connections (in. OD)	7/8	1-1/8	7/8	1-1/8	—	—	—	—	—	7/8	1-1/8	—	—	—	—	—
Distributor Nozzle Size	G-3	E-10	G-3	E-10	—	—	—	—	—	G-4	E-12	—	—	—	—	—
8-Row Coil																
Face Split Coils																
No. of TXVs	—	2	—	2	2	—	2	2	4	—	2	2	—	2	2	4
Suction Connections (in. OD)	—	1-1/8	—	1-1/8	1-3/8	—	1-3/8	1-5/8	1-5/8	—	1-1/8	1-3/8	—	1-3/8	1-5/8	1-5/8
Distributor Connections (in. OD)	—	7/8	—	7/8	1-1/8	—	1-1/8	1-3/8	1-3/8	—	7/8	1-1/8	—	1-1/8	1-3/8	1-3/8
Distributor Nozzle Size*	—	G-3	—	G-3	E-10	—	E-8	C-17	C-17	—	G-4 / G-3	E-12	—	E-8	C-17	C-17
Intertwined Row Split Coils																
No. of TXVs	—	2	—	2	2	—	2	2	4	—	2	2	—	2	2	4
Suction Connections (in. OD)	—	1-1/8	—	1-1/8	1-3/8	—	1-3/8	1-5/8	1-5/8	—	1-1/8	1-3/8	—	1-3/8	1-5/8	1-5/8
Distributor Connections (in. OD)	—	7/8	—	7/8	1-1/8	—	1-1/8	1-3/8	1-3/8	—	7/8	1-1/8	—	1-1/8	1-3/8	1-3/8
Distributor Nozzle Size*	—	G-3	—	G-3	E-10	—	E-8	C-17	C-17	—	G-4 / G-3	E-12	—	E-8	C-17	C-17
Single Circuit Coils																
No. of TXVs	—	1	—	1	—	—	—	—	—	—	1	—	—	—	—	—
Suction Connections (in. OD)	—	1-3/8	—	1-3/8	—	—	—	—	—	—	1-3/8	—	—	—	—	—
Distributor Connections (in. OD)	—	1-1/8	—	1-1/8	—	—	—	—	—	—	1-1/8	—	—	—	—	—
Distributor Nozzle Size	—	E-10	—	E-10	—	—	—	—	—	—	E-12	—	—	—	—	—

LEGEND

TXV — Thermostatic Expansion Valve (Field Supplied)

*When 2 nozzle sizes are listed, the smaller nozzle should be located on the upper distributor.

NOTE: Factory-supplied distributors have factory-selected nozzle sizes as shown. If necessary, replace factory-supplied nozzles with field-supplied and field-installed nozzles. Consult AHUBuilder® software selection program for correct nozzle selection.

Direct-Expansion Circuiting Data — Large Face Area Coils (cont)

39M UNIT SIZE	10W				11T				12W			12T			
	Quarter	Half	Full	Quarter	Half	Full	Double	Quarter	Half	Full	Quarter	Half	Full	Double	
CIRCUITING TYPE															
Airflow (cfm) at 500 fpm	4,965				5,833				6,319			6,380			
Total Face Area (sq ft)	9.9				11.7				12.6			12.8			
Tubes in Face	22	22	22	42	42	42	42	28	28	28	42	42	42	42	
Tube Length (in.)	52	52	52	32	32	32	32	52	52	52	35	35	35	35	
No. of Circuits - Total	6	11	22	10	21	42	84	7	14	28	10	21	42	84	
4-Row Coil															
Face Split Coils															
No. of TXVs	2	2	—	2	2	4	—	2	2	2	2	2	4	—	
Suction Connections (in. OD)	7/8	1-1/8	—	1-1/8	1-3/8	1-3/8	—	7/8	1-1/8	1-5/8	1-1/8	1-3/8	1-3/8	—	
Distributor Connections (in. OD)	7/8	7/8	—	7/8	1-1/8	1-1/8	—	7/8	7/8	1-3/8	7/8	1-1/8	1-1/8	—	
Distributor Nozzle Size*	G-2	G-4 / G-3	—	G-3	E-12 / E-10	E-12 / E-10	—	G-2.5 / G-2	G-6	C-15	G-3	E-12 / E-10	E-12 / E-10	—	
Intertwined Row Split Coils															
No. of TXVs	2	2	—	2	2	4	—	2	2	2	2	2	4	—	
Suction Connections (in. OD)	7/8	1-1/8	—	1-1/8	1-3/8	1-3/8	—	7/8	1-1/8	1-5/8	1-1/8	1-3/8	1-3/8	—	
Distributor Connections (in. OD)	7/8	7/8	—	7/8	1-1/8	1-1/8	—	7/8	7/8	1-3/8	7/8	1-1/8	1-1/8	—	
Distributor Nozzle Size*	G-2	G-4 / G-3	—	G-3	E-12 / E-10	E-12 / E-10	—	G-2.5 / G-2	G-6	C-15	G-3	E-12 / E-10	E-12 / E-10	—	
Single Circuit Coils															
No. of TXVs	1	1	—	1	—	—	—	1	1	—	1	—	—	—	
Suction Connections (in. OD)	1-1/8	1-3/8	—	1-3/8	—	—	—	1-1/8	1-5/8	—	1-3/8	—	—	—	
Distributor Connections (in. OD)	7/8	1-1/8	—	1-1/8	—	—	—	7/8	1-3/8	—	1-1/8	—	—	—	
Distributor Nozzle Size	G-4	E-12	—	E-10	—	—	—	G-6	C-15	—	E-10	—	—	—	
6-Row Coil															
Face Split Coils															
No. of TXVs	2	2	2	—	2	4	—	—	2	2	—	2	4	—	
Suction Connections (in. OD)	7/8	1-1/8	1-3/8	—	1-3/8	1-3/8	—	—	1-1/8	1-5/8	—	1-3/8	1-3/8	—	
Distributor Connections (in. OD)	7/8	7/8	1-1/8	—	1-1/8	1-1/8	—	—	7/8	1-3/8	—	1-1/8	1-1/8	—	
Distributor Nozzle Size*	G-2	G-4 / G-3	E-12	—	E-12 / E-10	E-12 / E-10	—	—	G-6	C-15	—	E-12 / E-10	E-12 / E-10	—	
Intertwined Row Split Coils															
No. of TXVs	2	2	2	—	2	4	—	—	2	2	—	2	4	—	
Suction Connections (in. OD)	7/8	1-1/8	1-3/8	—	1-3/8	1-3/8	—	—	1-1/8	1-5/8	—	1-3/8	1-3/8	—	
Distributor Connections (in. OD)	7/8	7/8	1-1/8	—	1-1/8	1-1/8	—	—	7/8	1-3/8	—	1-1/8	1-1/8	—	
Distributor Nozzle Size*	G-2	G-4 / G-3	E-12	—	E-12 / E-10	E-12 / E-10	—	—	G-6	C-15	—	E-12 / E-10	E-12 / E-10	—	
Single Circuit Coils															
No. of TXVs	1	1	—	—	—	—	—	—	1	—	—	—	—	—	
Suction Connections (in. OD)	1-1/8	1-3/8	—	—	—	—	—	—	1-5/8	—	—	—	—	—	
Distributor Connections (in. OD)	7/8	1-1/8	—	—	—	—	—	—	1-3/8	—	—	—	—	—	
Distributor Nozzle Size	G-4	E-12	—	—	—	—	—	—	C-15	—	—	—	—	—	
8-Row Coil															
Face Split Coils															
No. of TXVs	—	2	2	—	2	4	8	—	2	2	—	2	4	8	
Suction Connections (in. OD)	—	1-1/8	1-3/8	—	1-3/8	1-3/8	1-3/8	—	1-1/8	1-5/8	—	1-3/8	1-3/8	1-3/8	
Distributor Connections (in. OD)	—	7/8	1-1/8	—	1-1/8	1-1/8	1-1/8	—	7/8	1-3/8	—	1-1/8	1-1/8	1-1/8	
Distributor Nozzle Size*	—	G-4 / G-3	E-12	—	E-12 / E-10	E-12 / E-10	E-12 / E-10	—	G-6	C-15	—	E-12 / E-10	E-12 / E-10	E-12 / E-10	
Intertwined Row Split Coils															
No. of TXVs	—	2	2	—	2	4	8	—	2	2	—	2	4	8	
Suction Connections (in. OD)	—	1-1/8	1-3/8	—	1-3/8	1-3/8	1-3/8	—	1-1/8	1-5/8	—	1-3/8	1-3/8	1-3/8	
Distributor Connections (in. OD)	—	7/8	1-1/8	—	1-1/8	1-1/8	1-1/8	—	7/8	1-3/8	—	1-1/8	1-1/8	1-1/8	
Distributor Nozzle Size*	—	G-4 / G-3	E-12	—	E-12 / E-10	E-12 / E-10	E-12 / E-10	—	G-6	C-15	—	E-12 / E-10	E-12 / E-10	E-12 / E-10	
Single Circuit Coils															
No. of TXVs	—	1	—	—	—	—	—	—	1	—	—	—	—	—	
Suction Connections (in. OD)	—	1-3/8	—	—	—	—	—	—	1-5/8	—	—	—	—	—	
Distributor Connections (in. OD)	—	1-1/8	—	—	—	—	—	—	1-3/8	—	—	—	—	—	
Distributor Nozzle Size	—	E-12	—	—	—	—	—	—	C-15	—	—	—	—	—	

LEGEND

TXV — Thermostatic Expansion Valve (Field Supplied)

*When 2 nozzle sizes are listed, the smaller nozzle should be located on the upper distributor.

NOTE: Factory-supplied distributors have factory-selected nozzle sizes as shown. If necessary, replace factory-supplied nozzles with field-supplied and field-installed nozzles. Consult **AHUBuilder®** software selection program for correct nozzle selection.

Direct-Expansion Circuiting Data — Large Face Area Coils (cont)

CIRCUITING TYPE	14W			16T								17W		
	Quarter	Half	Full	Quarter		Half		Full	Double		Half	Full	Double	
Airflow (cfm) at 500 fpm	7,170			7,587								8,464		
Total Face Area (sq ft)	14.3			15.2								16.9		
Tubes in Face	28	28	28	22	24	22	24	22	24	22	24	30	30	30
Tube Length (in.)	59	59	59	38	38	38	38	38	38	38	38	65	65	65
No. of Circuits - Total	7	14	28	6	6	11	12	22	24	44	48	15	30	60
4-Row Coil				Upper	Lower	Upper	Lower	Upper	Lower	Upper	Lower			
Face Split Coils														
No. of TXVs	2	2	2	2	2	2	2	2	2	—	—	2	2	—
Suction Connections (in. OD)	7/8	1-1/8	1-5/8	7/8	7/8	1-1/8	1-1/8	1-3/8	1-3/8	—	—	1-1/8	1-5/8	—
Distributor Connections (in. OD)	7/8	7/8	1-3/8	7/8	7/8	7/8	7/8	1-1/8	1-3/8	—	—	7/8	1-3/8	—
Distributor Nozzle Size*	G-2.5 / G-2	G-6	C-15	G-2	G-2	G-4 / G-3	G-4	E-12	C-12	—	—	G-8 / G-6	C-15	—
Intertwined Row Split Coils														
No. of TXVs	2	2	2	2	2	2	2	2	2	—	—	2	2	—
Suction Connections (in. OD)	7/8	1-1/8	1-5/8	7/8	7/8	1-1/8	1-1/8	1-3/8	1-3/8	—	—	1-1/8	1-5/8	—
Distributor Connections (in. OD)	7/8	7/8	1-3/8	7/8	7/8	7/8	7/8	1-1/8	1-3/8	—	—	7/8	1-3/8	—
Distributor Nozzle Size*	G-2.5 / G-2	G-6	C-15	G-2	G-2	G-4 / G-3	G-4	E-12	C-12	—	—	G-8 / G-6	C-15	—
Single Circuit Coils														
No. of TXVs	1	1	—	1	1	1	1	—	—	—	—	1	—	—
Suction Connections (in. OD)	1-1/8	1-5/8	—	1-1/8	1-1/8	1-3/8	1-3/8	—	—	—	—	1-5/8	—	—
Distributor Connections (in. OD)	7/8	1-3/8	—	7/8	7/8	1-1/8	1-3/8	—	—	—	—	1-3/8	—	—
Distributor Nozzle Size	G-6	C-15	—	G-4	G-4	E-12	C-12	—	—	—	—	C-15	—	—
6-Row Coil														
Face Split Coils														
No. of TXVs	—	2	2	—	—	2	2	2	2	—	—	2	2	—
Suction Connections (in. OD)	—	1-1/8	1-5/8	—	—	1-1/8	1-1/8	1-3/8	1-3/8	—	—	1-1/8	1-5/8	—
Distributor Connections (in. OD)	—	7/8	1-3/8	—	—	7/8	7/8	1-1/8	1-3/8	—	—	7/8	1-3/8	—
Distributor Nozzle Size*	—	G-6	C-15	—	—	G-4 / G-3	G-4	E-12	C-12	—	—	G-8 / G-6	C-15	—
Intertwined Row Split Coils														
No. of TXVs	—	2	2	—	—	2	2	2	2	—	—	2	2	—
Suction Connections (in. OD)	—	1-1/8	1-5/8	—	—	1-1/8	1-1/8	1-3/8	1-3/8	—	—	1-1/8	1-5/8	—
Distributor Connections (in. OD)	—	7/8	1-3/8	—	—	7/8	7/8	1-1/8	1-3/8	—	—	7/8	1-3/8	—
Distributor Nozzle Size*	—	G-6	C-15	—	—	G-4 / G-3	G-4	E-12	C-12	—	—	G-8 / G-6	C-15	—
Single Circuit Coils														
No. of TXVs	—	1	—	—	—	1	1	—	—	—	—	1	—	—
Suction Connections (in. OD)	—	1-5/8	—	—	—	1-3/8	1-3/8	—	—	—	—	1-5/8	—	—
Distributor Connections (in. OD)	—	1-3/8	—	—	—	1-1/8	1-3/8	—	—	—	—	1-3/8	—	—
Distributor Nozzle Size	—	C-15	—	—	—	E-12	C-12	—	—	—	—	C-15	—	—
8-Row Coil														
Face Split Coils														
No. of TXVs	—	2	2	—	—	2	2	2	2	4	4	2	2	4
Suction Connections (in. OD)	—	1-1/8	1-5/8	—	—	1-1/8	1-1/8	1-3/8	1-3/8	1-3/8	1-3/8	1-1/8	1-5/8	1-5/8
Distributor Connections (in. OD)	—	7/8	1-3/8	—	—	7/8	7/8	1-1/8	1-3/8	1-1/8	1-3/8	7/8	1-3/8	1-3/8
Distributor Nozzle Size*	—	G-6	C-15	—	—	G-4 / G-3	G-4	E-12	C-12	E-12	C-12	G-8 / G-6	C-15	C-15
Intertwined Row Split Coils														
No. of TXVs	—	2	2	—	—	2	2	2	2	4	4	2	2	4
Suction Connections (in. OD)	—	1-1/8	1-5/8	—	—	1-1/8	1-1/8	1-3/8	1-3/8	1-3/8	1-3/8	1-1/8	1-5/8	1-5/8
Distributor Connections (in. OD)	—	7/8	1-3/8	—	—	7/8	7/8	1-1/8	1-3/8	1-1/8	1-3/8	7/8	1-3/8	1-3/8
Distributor Nozzle Size*	—	G-6	C-15	—	—	G-4 / G-3	G-4	E-12	C-12	E-12	C-12	G-8 / G-6	C-15	C-15
Single Circuit Coils														
No. of TXVs	—	1	—	—	—	—	—	—	—	—	—	1	—	—
Suction Connections (in. OD)	—	1-5/8	—	—	—	—	—	—	—	—	—	1-5/8	—	—
Distributor Connections (in. OD)	—	1-3/8	—	—	—	—	—	—	—	—	—	1-3/8	—	—
Distributor Nozzle Size	—	C-15	—	—	—	—	—	—	—	—	—	C-15	—	—

LEGEND

TXV — Thermostatic Expansion Valve (Field Supplied)

*When 2 nozzle sizes are listed, the smaller nozzle should be located on the upper distributor.

NOTE: Factory-supplied distributors have factory-selected nozzle sizes as shown. If necessary, replace factory-supplied nozzles with field-supplied and field-installed nozzles. Consult **AHUBuilder®** software selection program for correct nozzle selection.



Direct-Expansion Circuiting Data — Large Face Area Coils (cont)

39M UNIT SIZE	18T						21W			22T						25W		
CIRCUITING TYPE	Half		Full		Double		Half	Full	Double	Half		Full		Double		Half	Full	Double
Airflow (cfm) at 500 fpm	8,898						10,720			11,016						12,205		
Total Face Area (sq ft)	17.8						21.4			22.0						24.4		
Tubes in Face	24	26	24	26	24	26	38	38	38	26	28	26	28	26	28	38	38	38
Tube Length (in.)	41	41	41	41	41	41	65	65	65	47	47	47	47	47	47	74	74	74
No. of Circuits - Total	12	13	24	26	48	52	19	38	76	13	14	26	28	52	56	19	38	76
4-Row Coil	Upper	Lower	Upper	Lower	Upper	Lower				Upper	Lower	Upper	Lower	Upper	Lower			
Face Split Coils																		
No. of TXVs	2	2	2	2	—	—	2	2	—	2	2	2	2	—	—	2	2	—
Suction Connections (in. OD)	1-1/8	1-1/8	1-3/8	1-5/8	—	—	1-3/8	1-5/8	—	1-1/8	1-1/8	1-5/8	1-5/8	—	—	1-3/8	1-5/8	—
Distributor Connections (in. OD)	7/8	7/8	1-3/8	1-3/8	—	—	1-1/8	1-3/8	—	7/8	7/8	1-3/8	1-3/8	—	—	1-1/8	1-3/8	—
Distributor Nozzle Size*	G-4	G-6 / G-4	C-12	C-12	—	—	E-10 / E-8	C-20	—	G-6 / G-4	G-6	C-12	C-15	—	—	E-10 / E-8	C-20	—
Intertwined Row Split Coils																		
No. of TXVs	2	2	2	2	—	—	2	2	—	2	2	2	2	—	—	2	2	—
Suction Connections (in. OD)	1-1/8	1-1/8	1-3/8	1-5/8	—	—	1-3/8	1-5/8	—	1-1/8	1-1/8	1-5/8	1-5/8	—	—	1-3/8	1-5/8	—
Distributor Connections (in. OD)	7/8	7/8	1-3/8	1-3/8	—	—	1-1/8	1-3/8	—	7/8	7/8	1-3/8	1-3/8	—	—	1-1/8	1-3/8	—
Distributor Nozzle Size*	G-4	G-6 / G-4	C-12	C-12	—	—	E-10 / E-8	C-20	—	G-6 / G-4	G-6	C-12	C-15	—	—	E-10 / E-8	C-20	—
Single Circuit Coils																		
No. of TXVs	—	—	—	—	—	—	—	—	—	—	—	—	—	—	—	—	—	—
Suction Connections (in. OD)	—	—	—	—	—	—	—	—	—	—	—	—	—	—	—	—	—	—
Distributor Connections (in. OD)	—	—	—	—	—	—	—	—	—	—	—	—	—	—	—	—	—	—
Distributor Nozzle Size	—	—	—	—	—	—	—	—	—	—	—	—	—	—	—	—	—	—
6-Row Coil																		
Face Split Coils																		
No. of TXVs	2	2	2	2	—	—	2	2	—	2	2	2	2	—	—	2	2	—
Suction Connections (in. OD)	1-1/8	1-1/8	1-3/8	1-5/8	—	—	1-3/8	1-5/8	—	1-1/8	1-1/8	1-5/8	1-5/8	—	—	1-3/8	1-5/8	—
Distributor Connections (in. OD)	7/8	7/8	1-3/8	1-3/8	—	—	1-1/8	1-3/8	—	7/8	7/8	1-3/8	1-3/8	—	—	1-1/8	1-3/8	—
Distributor Nozzle Size*	G-4	G-6 / G-4	C-12	C-12	—	—	E-10 / E-8	C-20	—	G-6 / G-4	G-6	C-12	C-15	—	—	E-10 / E-8	C-20	—
Intertwined Row Split Coils																		
No. of TXVs	2	2	2	2	—	—	2	2	—	2	2	2	2	—	—	2	2	—
Suction Connections (in. OD)	1-1/8	1-1/8	1-3/8	1-5/8	—	—	1-3/8	1-5/8	—	1-1/8	1-1/8	1-5/8	1-5/8	—	—	1-3/8	1-5/8	—
Distributor Connections (in. OD)	7/8	7/8	1-3/8	1-3/8	—	—	1-1/8	1-3/8	—	7/8	7/8	1-3/8	1-3/8	—	—	1-1/8	1-3/8	—
Distributor Nozzle Size*	G-4	G-6 / G-4	C-12	C-12	—	—	E-10 / E-8	C-20	—	G-6 / G-4	G-6	C-12	C-15	—	—	E-10 / E-8	C-20	—
Single Circuit Coils																		
No. of TXVs	—	—	—	—	—	—	—	—	—	—	—	—	—	—	—	—	—	—
Suction Connections (in. OD)	—	—	—	—	—	—	—	—	—	—	—	—	—	—	—	—	—	—
Distributor Connections (in. OD)	—	—	—	—	—	—	—	—	—	—	—	—	—	—	—	—	—	—
Distributor Nozzle Size	—	—	—	—	—	—	—	—	—	—	—	—	—	—	—	—	—	—
8-Row Coil																		
Face Split Coils																		
No. of TXVs	2	2	2	2	4	4	2	2	4	2	2	2	2	4	4	2	2	4
Suction Connections (in. OD)	1-1/8	1-1/8	1-3/8	1-5/8	1-3/8	1-5/8	1-3/8	1-5/8	1-5/8	1-1/8	1-1/8	1-5/8	1-5/8	1-5/8	1-5/8	1-3/8	1-5/8	1-5/8
Distributor Connections (in. OD)	7/8	7/8	1-3/8	1-3/8	1-3/8	1-3/8	1-1/8	1-3/8	1-3/8	7/8	7/8	1-3/8	1-3/8	1-3/8	1-3/8	1-1/8	1-3/8	1-3/8
Distributor Nozzle Size*	G-4	G-6 / G-4	C-12	C-12	C-12	C-12	E-10 / E-8	C-20	C-20	G-6 / G-4	G-6	C-12	C-15	C-12	C-15	E-10 / E-8	C-20	C-20
Intertwined Row Split Coils																		
No. of TXVs	2	2	2	2	4	4	2	2	4	2	2	2	2	4	4	2	2	4
Suction Connections (in. OD)	1-1/8	1-1/8	1-3/8	1-5/8	1-3/8	1-5/8	1-3/8	1-5/8	1-5/8	1-1/8	1-1/8	1-5/8	1-5/8	1-5/8	1-5/8	1-3/8	1-5/8	1-5/8
Distributor Connections (in. OD)	7/8	7/8	1-3/8	1-3/8	1-3/8	1-3/8	1-1/8	1-3/8	1-3/8	7/8	7/8	1-3/8	1-3/8	1-3/8	1-3/8	1-1/8	1-3/8	1-3/8
Distributor Nozzle Size*	G-4	G-6 / G-4	C-12	C-12	C-12	C-12	E-10 / E-8	C-20	C-20	G-6 / G-4	G-6	C-12	C-15	C-12	C-15	E-10 / E-8	C-20	C-20
Single Circuit Coils																		
No. of TXVs	—	—	—	—	—	—	—	—	—	—	—	—	—	—	—	—	—	—
Suction Connections (in. OD)	—	—	—	—	—	—	—	—	—	—	—	—	—	—	—	—	—	—
Distributor Connections (in. OD)	—	—	—	—	—	—	—	—	—	—	—	—	—	—	—	—	—	—
Distributor Nozzle Size	—	—	—	—	—	—	—	—	—	—	—	—	—	—	—	—	—	—

LEGEND

TXV — Thermostatic Expansion Valve (Field Supplied)

*When 2 nozzle sizes are listed, the smaller nozzle should be located on the upper distributor.

NOTE: Factory-supplied distributors have factory-selected nozzle sizes as shown. If necessary, replace factory-supplied nozzles with field-supplied and field-installed nozzles. Consult **AHUBuilder®** software selection program for correct nozzle selection.

Direct-Expansion Circuiting Data — Large Face Area Coils (cont)

39M UNIT SIZE	25T						30W			30T					
	Half		Full		Double		Half	Full	Double	Half		Full		Double	
Airflow (cfm) at 500 fpm	12,335						15,174			14,852					
Total Face Area (sq ft)	24.7						30.3			29.7					
Tubes in Face	28	30	28	30	28	30	38	38	38	28	30	28	30	28	30
Tube Length (in.)	49	49	49	49	49	49	92	92	92	59	59	59	59	59	59
No. of Circuits - Total	14	15	28	30	56	60	19	38	76	14	15	28	30	56	60
4-Row Coil	Upper	Lower	Upper	Lower	Upper	Lower				Upper	Lower	Upper	Lower	Upper	Lower
Face Split Coils															
No. of TXVs	2	2	2	2	—	—	2	2	—	2	2	2	2	—	—
Suction Connections (in. OD)	1-1/8	1-1/8	1-5/8	1-5/8	—	—	1-3/8	1-5/8	—	1-1/8	1-1/8	1-5/8	1-5/8	—	—
Distributor Connections (in. OD)	7/8	7/8	1-3/8	1-3/8	—	—	1-1/8	1-3/8	—	7/8	7/8	1-3/8	1-3/8	—	—
Distributor Nozzle Size*	G-6	G-8 / G-6	C-15	C-15	—	—	E-10 / E-8	C-20	—	G-6	G-8 / G-6	C-15	C-15	—	—
Intertwined Row Split Coils															
No. of TXVs	2	2	2	2	—	—	2	2	—	2	2	2	2	—	—
Suction Connections (in. OD)	1-1/8	1-1/8	1-5/8	1-5/8	—	—	1-3/8	1-5/8	—	1-1/8	1-1/8	1-5/8	1-5/8	—	—
Distributor Connections (in. OD)	7/8	7/8	1-3/8	1-3/8	—	—	1-1/8	1-3/8	—	7/8	7/8	1-3/8	1-3/8	—	—
Distributor Nozzle Size*	G-6	G-8 / G-6	C-15	C-15	—	—	E-10 / E-8	C-20	—	G-6	G-8 / G-6	C-15	C-15	—	—
Single Circuit Coils															
No. of TXVs	—	—	—	—	—	—	—	—	—	—	—	—	—	—	—
Suction Connections (in. OD)	—	—	—	—	—	—	—	—	—	—	—	—	—	—	—
Distributor Connections (in. OD)	—	—	—	—	—	—	—	—	—	—	—	—	—	—	—
Distributor Nozzle Size	—	—	—	—	—	—	—	—	—	—	—	—	—	—	—
6-Row Coil															
Face Split Coils															
No. of TXVs	2	2	2	2	—	—	2	2	—	2	2	2	2	—	—
Suction Connections (in. OD)	1-1/8	1-1/8	1-5/8	1-5/8	—	—	1-3/8	1-5/8	—	1-1/8	1-1/8	1-5/8	1-5/8	—	—
Distributor Connections (in. OD)	7/8	7/8	1-3/8	1-3/8	—	—	1-1/8	1-3/8	—	7/8	7/8	1-3/8	1-3/8	—	—
Distributor Nozzle Size*	G-6	G-8 / G-6	C-15	C-15	—	—	E-10 / E-8	C-20	—	G-6	G-8 / G-6	C-15	C-15	—	—
Intertwined Row Split Coils															
No. of TXVs	2	2	2	2	—	—	2	2	—	2	2	2	2	—	—
Suction Connections (in. OD)	1-1/8	1-1/8	1-5/8	1-5/8	—	—	1-3/8	1-5/8	—	1-1/8	1-1/8	1-5/8	1-5/8	—	—
Distributor Connections (in. OD)	7/8	7/8	1-3/8	1-3/8	—	—	1-1/8	1-3/8	—	7/8	7/8	1-3/8	1-3/8	—	—
Distributor Nozzle Size*	G-6	G-8 / G-6	C-15	C-15	—	—	E-10 / E-8	C-20	—	G-6	G-8 / G-6	C-15	C-15	—	—
Single Circuit Coils															
No. of TXVs	—	—	—	—	—	—	—	—	—	—	—	—	—	—	—
Suction Connections (in. OD)	—	—	—	—	—	—	—	—	—	—	—	—	—	—	—
Distributor Connections (in. OD)	—	—	—	—	—	—	—	—	—	—	—	—	—	—	—
Distributor Nozzle Size	—	—	—	—	—	—	—	—	—	—	—	—	—	—	—
8-Row Coil															
Face Split Coils															
No. of TXVs	2	2	2	2	4	4	2	2	4	2	2	2	2	4	4
Suction Connections (in. OD)	1-1/8	1-1/8	1-5/8	1-5/8	1-5/8	1-5/8	1-3/8	1-5/8	1-5/8	1-1/8	1-1/8	1-5/8	1-5/8	1-5/8	1-5/8
Distributor Connections (in. OD)	7/8	7/8	1-3/8	1-3/8	1-3/8	1-3/8	1-1/8	1-3/8	1-3/8	7/8	7/8	1-3/8	1-3/8	1-3/8	1-3/8
Distributor Nozzle Size*	G-6	G-8 / G-6	C-15	C-15	C-15	C-15	E-10 / E-8	C-20	C-20	G-6	G-8 / G-6	C-15	C-15	C-15	C-15
Intertwined Row Split Coils															
No. of TXVs	2	2	2	2	4	4	2	2	4	2	2	2	2	4	4
Suction Connections (in. OD)	1-1/8	1-1/8	1-5/8	1-5/8	1-5/8	1-5/8	1-3/8	1-5/8	1-5/8	1-1/8	1-1/8	1-5/8	1-5/8	1-5/8	1-5/8
Distributor Connections (in. OD)	7/8	7/8	1-3/8	1-3/8	1-3/8	1-3/8	1-1/8	1-3/8	1-3/8	7/8	7/8	1-3/8	1-3/8	1-3/8	1-3/8
Distributor Nozzle Size*	G-6	G-8 / G-6	C-15	C-15	C-15	C-15	E-10 / E-8	C-20	C-20	G-6	G-8 / G-6	C-15	C-15	C-15	C-15
Single Circuit Coils															
No. of TXVs	—	—	—	—	—	—	—	—	—	—	—	—	—	—	—
Suction Connections (in. OD)	—	—	—	—	—	—	—	—	—	—	—	—	—	—	—
Distributor Connections (in. OD)	—	—	—	—	—	—	—	—	—	—	—	—	—	—	—
Distributor Nozzle Size	—	—	—	—	—	—	—	—	—	—	—	—	—	—	—

LEGEND

TXV — Thermostatic Expansion Valve (Field Supplied)

*When 2 nozzle sizes are listed, the smaller nozzle should be located on the upper distributor.

NOTE: Factory-supplied distributors have factory-selected nozzle sizes as shown. If necessary, replace factory-supplied nozzles with field-supplied and field-installed nozzles. Consult **AHUBuilder®** software selection program for correct nozzle selection.

Direct-Expansion Circuiting Data — Large Face Area Coils (cont)

39M UNIT SIZE	35T						36W		37T						40W			
	Half		Full		Double		Full	Double	Half		Full		Double		Full		Double	
CIRCUITING TYPE																		
Airflow (cfm) at 500 fpm	17,448						18,333		18,438						20,000			
Total Face Area (sq ft)	34.9						36.7		36.9						40.0			
Tubes in Face	30	30	30	30	30	30	44	44	36	36	36	36	36	36	24	24	24	24
Tube Length (in.)	67	67	67	67	67	67	96	96	59	59	59	59	59	59	96	96	96	96
No. of Circuits - Total	15	15	30	30	60	60	44	88	18	18	36	36	72	72	24	24	48	48
4-Row Coil	Upper	Lower	Upper	Lower	Upper	Lower			Upper	Lower	Upper	Lower	Upper	Lower	Upper	Lower	Upper	Lower
Face Split Coils																		
No. of TXVs	2	2	2	2	—	—	4	—	2	2	2	2	—	—	2	2	—	—
Suction Connections (in. OD)	1-1/8	1-1/8	1-5/8	1-5/8	—	—	1-3/8	—	1-3/8	1-3/8	1-5/8	1-5/8	—	—	1-3/8	1-3/8	—	—
Distributor Connections (in. OD)	7/8	7/8	1-3/8	1-3/8	—	—	1-1/8	—	1-1/8	1-1/8	1-3/8	1-3/8	—	—	1-3/8	1-3/8	—	—
Distributor Nozzle Size*	G-8 / G-6	G-8 / G-6	C-15	C-15	—	—	E-12	—	E-8	E-8	C-17	C-17	—	—	C-12	C-12	—	—
Intertwined Row Split Coils																		
No. of TXVs	2	2	2	2	—	—	4	—	2	2	2	2	—	—	2	2	—	—
Suction Connections (in. OD)	1-1/8	1-1/8	1-5/8	1-5/8	—	—	1-3/8	—	1-3/8	1-3/8	1-5/8	1-5/8	—	—	1-3/8	1-3/8	—	—
Distributor Connections (in. OD)	7/8	7/8	1-3/8	1-3/8	—	—	1-1/8	—	1-1/8	1-1/8	1-3/8	1-3/8	—	—	1-3/8	1-3/8	—	—
Distributor Nozzle Size*	G-8 / G-6	G-8 / G-6	C-15	C-15	—	—	E-12	—	E-8	E-8	C-17	C-17	—	—	C-12	C-12	—	—
Single Circuit Coils																		
No. of TXVs	—	—	—	—	—	—	—	—	—	—	—	—	—	—	—	—	—	—
Suction Connections (in. OD)	—	—	—	—	—	—	—	—	—	—	—	—	—	—	—	—	—	—
Distributor Connections (in. OD)	—	—	—	—	—	—	—	—	—	—	—	—	—	—	—	—	—	—
Distributor Nozzle Size	—	—	—	—	—	—	—	—	—	—	—	—	—	—	—	—	—	—
6-Row Coil																		
Face Split Coils																		
No. of TXVs	2	2	2	2	—	—	4	—	2	2	2	2	—	—	2	2	—	—
Suction Connections (in. OD)	1-1/8	1-1/8	1-5/8	1-5/8	—	—	1-3/8	—	1-3/8	1-3/8	1-5/8	1-5/8	—	—	1-3/8	1-3/8	—	—
Distributor Connections (in. OD)	7/8	7/8	1-3/8	1-3/8	—	—	1-1/8	—	1-1/8	1-1/8	1-3/8	1-3/8	—	—	1-3/8	1-3/8	—	—
Distributor Nozzle Size*	G-8 / G-6	G-8 / G-6	C-15	C-15	—	—	E-12	—	E-8	E-8	C-17	C-17	—	—	C-12	C-12	—	—
Intertwined Row Split Coils																		
No. of TXVs	2	2	2	2	—	—	4	—	2	2	2	2	—	—	2	2	—	—
Suction Connections (in. OD)	1-1/8	1-1/8	1-5/8	1-5/8	—	—	1-3/8	—	1-3/8	1-3/8	1-5/8	1-5/8	—	—	1-3/8	1-3/8	—	—
Distributor Connections (in. OD)	7/8	7/8	1-3/8	1-3/8	—	—	1-1/8	—	1-1/8	1-1/8	1-3/8	1-3/8	—	—	1-3/8	1-3/8	—	—
Distributor Nozzle Size*	G-8 / G-6	G-8 / G-6	C-15	C-15	—	—	E-12	—	E-8	E-8	C-17	C-17	—	—	C-12	C-12	—	—
Single Circuit Coils																		
No. of TXVs	—	—	—	—	—	—	—	—	—	—	—	—	—	—	—	—	—	—
Suction Connections (in. OD)	—	—	—	—	—	—	—	—	—	—	—	—	—	—	—	—	—	—
Distributor Connections (in. OD)	—	—	—	—	—	—	—	—	—	—	—	—	—	—	—	—	—	—
Distributor Nozzle Size	—	—	—	—	—	—	—	—	—	—	—	—	—	—	—	—	—	—
8-Row Coil																		
Face Split Coils																		
No. of TXVs	2	2	2	2	4	4	4	8	2	2	2	2	4	4	2	2	4	4
Suction Connections (in. OD)	1-1/8	1-1/8	1-5/8	1-5/8	1-5/8	1-5/8	1-3/8	1-3/8	1-3/8	1-3/8	1-5/8	1-5/8	1-5/8	1-5/8	1-3/8	1-3/8	1-3/8	1-3/8
Distributor Connections (in. OD)	7/8	7/8	1-3/8	1-3/8	1-3/8	1-3/8	1-1/8	1-1/8	1-1/8	1-1/8	1-3/8	1-3/8	1-3/8	1-3/8	1-3/8	1-3/8	1-3/8	1-3/8
Distributor Nozzle Size*	G-8 / G-6	G-8 / G-6	C-15	C-15	C-15	C-15	E-12	E-12	E-8	E-8	C-17	C-17	C-17	C-17	C-12	C-12	C-12	C-12
Intertwined Row Split Coils																		
No. of TXVs	2	2	2	2	4	4	4	8	2	2	2	2	4	4	2	2	4	4
Suction Connections (in. OD)	1-1/8	1-1/8	1-5/8	1-5/8	1-5/8	1-5/8	1-3/8	1-3/8	1-3/8	1-3/8	1-5/8	1-5/8	1-5/8	1-5/8	1-3/8	1-3/8	1-3/8	1-3/8
Distributor Connections (in. OD)	7/8	7/8	1-3/8	1-3/8	1-3/8	1-3/8	1-1/8	1-1/8	1-1/8	1-1/8	1-3/8	1-3/8	1-3/8	1-3/8	1-3/8	1-3/8	1-3/8	1-3/8
Distributor Nozzle Size*	G-8 / G-6	G-8 / G-6	C-15	C-15	C-15	C-15	E-12	E-12	E-8	E-8	C-17	C-17	C-17	C-17	C-12	C-12	C-12	C-12
Single Circuit Coils																		
No. of TXVs	—	—	—	—	—	—	—	—	—	—	—	—	—	—	—	—	—	—
Suction Connections (in. OD)	—	—	—	—	—	—	—	—	—	—	—	—	—	—	—	—	—	—
Distributor Connections (in. OD)	—	—	—	—	—	—	—	—	—	—	—	—	—	—	—	—	—	—
Distributor Nozzle Size	—	—	—	—	—	—	—	—	—	—	—	—	—	—	—	—	—	—

LEGEND

TXV — Thermostatic Expansion Valve (Field Supplied)

*When 2 nozzle sizes are listed, the smaller nozzle should be located on the upper distributor.

NOTE: Factory-supplied distributors have factory-selected nozzle sizes as shown. If necessary, replace factory-supplied nozzles with field-supplied and field-installed nozzles. Consult **AHUBuilder®** software selection program for correct nozzle selection.

Direct-Expansion Circuiting Data — Large Face Area Coils (cont)

39M UNIT SIZE	42T						50W				51T					
	Half		Full		Double		Full		Double		Quarter	Half		Full		Double
CIRCUITING TYPE	20,938						25,278				25,313					
Airflow (cfm) at 500 fpm	41.9						50.6				50.6					
Total Face Area (sq ft)	36	36	36	36	36	36	28	28	28	28	—	36	36	36	36	36
Tubes in Face	67	67	67	67	67	67	104	104	104	104	—	81	81	81	81	81
Tube Length (in.)	18	18	36	36	72	72	28	28	56	56	—	18	18	36	36	72
No. of Circuits - Total	18	18	36	36	72	72	28	28	56	56	—	18	18	36	36	72
4-Row Coil	Upper	Lower	Upper	Lower	Upper	Lower	Upper	Lower	Upper	Lower	—	Upper	Lower	Upper	Lower	Upper
Face Split Coils																
No. of TXVs	2	2	2	2	—	—	2	2	—	—	—	2	2	2	2	—
Suction Connections (in. OD)	1-3/8	1-3/8	1-5/8	1-5/8	—	—	1-5/8	1-5/8	—	—	—	1-3/8	1-3/8	1-5/8	1-5/8	—
Distributor Connections (in. OD)	1-1/8	1-1/8	1-3/8	1-3/8	—	—	1-3/8	1-3/8	—	—	—	1-1/8	1-1/8	1-3/8	1-3/8	—
Distributor Nozzle Size	E-8	E-8	C-17	C-17	—	—	C-15	C-15	—	—	—	E-8	E-8	C-17	C-17	—
Intertwined Row Split Coils																
No. of TXVs	2	2	2	2	—	—	2	2	—	—	—	2	2	2	2	—
Suction Connections (in. OD)	1-3/8	1-3/8	1-5/8	1-5/8	—	—	1-5/8	1-5/8	—	—	—	1-3/8	1-3/8	1-5/8	1-5/8	—
Distributor Connections (in. OD)	1-1/8	1-1/8	1-3/8	1-3/8	—	—	1-3/8	1-3/8	—	—	—	1-1/8	1-1/8	1-3/8	1-3/8	—
Distributor Nozzle Size	E-8	E-8	C-17	C-17	—	—	C-15	C-15	—	—	—	E-8	E-8	C-17	C-17	—
Single Circuit Coils																
No. of TXVs	—	—	—	—	—	—	—	—	—	—	—	—	—	—	—	—
Suction Connections (in. OD)	—	—	—	—	—	—	—	—	—	—	—	—	—	—	—	—
Distributor Connections (in. OD)	—	—	—	—	—	—	—	—	—	—	—	—	—	—	—	—
Distributor Nozzle Size	—	—	—	—	—	—	—	—	—	—	—	—	—	—	—	—
6-Row Coil																
Face Split Coils																
No. of TXVs	2	2	2	2	—	—	2	2	—	—	—	2	2	2	2	—
Suction Connections (in. OD)	1-3/8	1-3/8	1-5/8	1-5/8	—	—	1-5/8	1-5/8	—	—	—	1-3/8	1-3/8	1-5/8	1-5/8	—
Distributor Connections (in. OD)	1-1/8	1-1/8	1-3/8	1-3/8	—	—	1-3/8	1-3/8	—	—	—	1-1/8	1-1/8	1-3/8	1-3/8	—
Distributor Nozzle Size	E-8	E-8	C-17	C-17	—	—	C-15	C-15	—	—	—	E-8	E-8	C-17	C-17	—
Intertwined Row Split Coils																
No. of TXVs	2	2	2	2	—	—	2	2	—	—	—	2	2	2	2	—
Suction Connections (in. OD)	1-3/8	1-3/8	1-5/8	1-5/8	—	—	1-5/8	1-5/8	—	—	—	1-3/8	1-3/8	1-5/8	1-5/8	—
Distributor Connections (in. OD)	1-1/8	1-1/8	1-3/8	1-3/8	—	—	1-3/8	1-3/8	—	—	—	1-1/8	1-1/8	1-3/8	1-3/8	—
Distributor Nozzle Size	E-8	E-8	C-17	C-17	—	—	C-15	C-15	—	—	—	E-8	E-8	C-17	C-17	—
Single Circuit Coils																
No. of TXVs	—	—	—	—	—	—	—	—	—	—	—	—	—	—	—	—
Suction Connections (in. OD)	—	—	—	—	—	—	—	—	—	—	—	—	—	—	—	—
Distributor Connections (in. OD)	—	—	—	—	—	—	—	—	—	—	—	—	—	—	—	—
Distributor Nozzle Size	—	—	—	—	—	—	—	—	—	—	—	—	—	—	—	—
8-Row Coil																
Face Split Coils																
No. of TXVs	2	2	2	2	4	4	2	2	4	4	—	2	2	2	2	4
Suction Connections (in. OD)	1-3/8	1-3/8	1-5/8	1-5/8	1-5/8	1-5/8	1-5/8	1-5/8	1-5/8	1-5/8	—	1-3/8	1-3/8	1-5/8	1-5/8	1-5/8
Distributor Connections (in. OD)	1-1/8	1-1/8	1-3/8	1-3/8	1-3/8	1-3/8	1-3/8	1-3/8	1-3/8	1-3/8	—	1-1/8	1-1/8	1-3/8	1-3/8	1-3/8
Distributor Nozzle Size	E-8	E-8	C-17	C-17	C-17	C-17	C-15	C-15	C-15	C-15	—	E-8	E-8	C-17	C-17	C-17
Intertwined Row Split Coils																
No. of TXVs	2	2	2	2	4	4	2	2	4	4	—	2	2	2	2	4
Suction Connections (in. OD)	1-3/8	1-3/8	1-5/8	1-5/8	1-5/8	1-5/8	1-5/8	1-5/8	1-5/8	1-5/8	—	1-3/8	1-3/8	1-5/8	1-5/8	1-5/8
Distributor Connections (in. OD)	1-1/8	1-1/8	1-3/8	1-3/8	1-3/8	1-3/8	1-3/8	1-3/8	1-3/8	1-3/8	—	1-1/8	1-1/8	1-3/8	1-3/8	1-3/8
Distributor Nozzle Size	E-8	E-8	C-17	C-17	C-17	C-17	C-15	C-15	C-15	C-15	—	E-8	E-8	C-17	C-17	C-17
Single Circuit Coils																
No. of TXVs	—	—	—	—	—	—	—	—	—	—	—	—	—	—	—	—
Suction Connections (in. OD)	—	—	—	—	—	—	—	—	—	—	—	—	—	—	—	—
Distributor Connections (in. OD)	—	—	—	—	—	—	—	—	—	—	—	—	—	—	—	—
Distributor Nozzle Size	—	—	—	—	—	—	—	—	—	—	—	—	—	—	—	—

LEGEND

TXV — Thermostatic Expansion Valve (Field Supplied)

*When 2 nozzle sizes are listed, the smaller nozzle should be located on the upper distributor.

NOTE: Factory-supplied distributors have factory-selected nozzle sizes as shown. If necessary, replace factory-supplied nozzles with field-supplied and field-installed nozzles. Consult **AHUBuilder®** software selection program for correct nozzle selection.

Direct-Expansion Circuiting Data — Large Face Area Coils (cont)

CIRCUITING TYPE	39M UNIT SIZE				58T				61W				72W				85W			
	Full		Double		Full		Double		Full		Double		Full		Double		Full		Double	
Airflow (cfm) at 500 fpm	28,828				30,694				36,224				42,656							
Total Face Area (sq ft)	57.7				61.4				72.4				85.3							
Tubes in Face	40	42	40	42	34	34	34	34	38	38	38	38	38	38	38	38				
Tube Length (in.)	81	81	81	81	104	104	104	104	107	107	107	107	126	126	126	126				
No. of Circuits - Total	40	42	80	84	34	34	68	68	38	38	76	76	38	38	76	76				
4-Row Coil	Upper	Lower	Upper	Lower	Upper	Lower	Upper	Lower	Upper	Lower	Upper	Lower	Upper	Lower	Upper	Lower				
Face Split Coils																				
No. of TXVs	4	4	—	—	2	2	—	—	2	2	—	—	2	2	—	—				
Suction Connections (in. OD)	1-3/8	1-3/8	—	—	1-5/8	1-5/8	—	—	1-5/8	1-5/8	—	—	1-5/8	1-5/8	—	—				
Distributor Connections (in. OD)	1-1/8	1-1/8	—	—	1-3/8	1-3/8	—	—	1-3/8	1-3/8	—	—	1-3/8	1-3/8	—	—				
Distributor Nozzle Size*	E-10	E-12/ E-10	—	—	C-17	C-17	—	—	C-20	C-20	—	—	C-20	C-20	—	—				
Intertwined Row Split Coils																				
No. of TXVs	4	4	—	—	2	2	—	—	2	2	—	—	2	2	—	—				
Suction Connections (in. OD)	1-3/8	1-3/8	—	—	1-5/8	1-5/8	—	—	1-5/8	1-5/8	—	—	1-5/8	1-5/8	—	—				
Distributor Connections (in. OD)	1-1/8	1-1/8	—	—	1-3/8	1-3/8	—	—	1-3/8	1-3/8	—	—	1-3/8	1-3/8	—	—				
Distributor Nozzle Size*	E-10	E-12/ E-10	—	—	C-17	C-17	—	—	C-20	C-20	—	—	C-20	C-20	—	—				
Single Circuit Coils																				
No. of TXVs	—	—	—	—	—	—	—	—	—	—	—	—	—	—	—	—				
Suction Connections (in. OD)	—	—	—	—	—	—	—	—	—	—	—	—	—	—	—	—				
Distributor Connections (in. OD)	—	—	—	—	—	—	—	—	—	—	—	—	—	—	—	—				
Distributor Nozzle Size	—	—	—	—	—	—	—	—	—	—	—	—	—	—	—	—				
6-Row Coil																				
Face Split Coils																				
No. of TXVs	4	4	—	—	2	2	—	—	2	2	—	—	2	2	—	—				
Suction Connections (in. OD)	1-3/8	1-3/8	—	—	1-5/8	1-5/8	—	—	1-5/8	1-5/8	—	—	1-5/8	1-5/8	—	—				
Distributor Connections (in. OD)	1-1/8	1-1/8	—	—	1-3/8	1-3/8	—	—	1-3/8	1-3/8	—	—	1-3/8	1-3/8	—	—				
Distributor Nozzle Size*	E-10	E-12/ E-10	—	—	C-17	C-17	—	—	C-20	C-20	—	—	C-20	C-20	—	—				
Intertwined Row Split Coils																				
No. of TXVs	4	4	—	—	2	2	—	—	2	2	—	—	2	2	—	—				
Suction Connections (in. OD)	1-3/8	1-3/8	—	—	1-5/8	1-5/8	—	—	1-5/8	1-5/8	—	—	1-5/8	1-5/8	—	—				
Distributor Connections (in. OD)	1-1/8	1-1/8	—	—	1-3/8	1-3/8	—	—	1-3/8	1-3/8	—	—	1-3/8	1-3/8	—	—				
Distributor Nozzle Size*	E-10	E-12/ E-10	—	—	C-17	C-17	—	—	C-20	C-20	—	—	C-20	C-20	—	—				
Single Circuit Coils																				
No. of TXVs	—	—	—	—	—	—	—	—	—	—	—	—	—	—	—	—				
Suction Connections (in. OD)	—	—	—	—	—	—	—	—	—	—	—	—	—	—	—	—				
Distributor Connections (in. OD)	—	—	—	—	—	—	—	—	—	—	—	—	—	—	—	—				
Distributor Nozzle Size	—	—	—	—	—	—	—	—	—	—	—	—	—	—	—	—				
8-Row Coil																				
Face Split Coils																				
No. of TXVs	4	4	8	8	2	2	4	4	2	2	4	4	2	2	4	4				
Suction Connections (in. OD)	1-3/8	1-3/8	1-3/8	1-3/8	1-5/8	1-5/8	1-5/8	1-5/8	1-5/8	1-5/8	1-5/8	1-5/8	1-5/8	1-5/8	1-5/8	1-5/8				
Distributor Connections (in. OD)	1-1/8	1-1/8	1-1/8	1-1/8	1-3/8	1-3/8	1-3/8	1-3/8	1-3/8	1-3/8	1-3/8	1-3/8	1-3/8	1-3/8	1-3/8	1-3/8				
Distributor Nozzle Size*	E-10	E-12/ E-10	E-10	E-12/ E-10	C-17	C-17	C-17	C-17	C-20	C-20	C-20	C-20	C-20	C-20	C-20	C-20				
Intertwined Row Split Coils																				
No. of TXVs	4	4	8	8	2	2	4	4	2	2	4	4	2	2	4	4				
Suction Connections (in. OD)	1-3/8	1-3/8	1-3/8	1-3/8	1-5/8	1-5/8	1-5/8	1-5/8	1-5/8	1-5/8	1-5/8	1-5/8	1-5/8	1-5/8	1-5/8	1-5/8				
Distributor Connections (in. OD)	1-1/8	1-1/8	1-1/8	1-1/8	1-3/8	1-3/8	1-3/8	1-3/8	1-3/8	1-3/8	1-3/8	1-3/8	1-3/8	1-3/8	1-3/8	1-3/8				
Distributor Nozzle Size*	E-10	E-12/ E-10	E-10	E-12/ E-10	C-17	C-17	C-17	C-17	C-20	C-20	C-20	C-20	C-20	C-20	C-20	C-20				
Single Circuit Coils																				
No. of TXVs	—	—	—	—	—	—	—	—	—	—	—	—	—	—	—	—				
Suction Connections (in. OD)	—	—	—	—	—	—	—	—	—	—	—	—	—	—	—	—				
Distributor Connections (in. OD)	—	—	—	—	—	—	—	—	—	—	—	—	—	—	—	—				
Distributor Nozzle Size	—	—	—	—	—	—	—	—	—	—	—	—	—	—	—	—				

LEGEND

TXV — Thermostatic Expansion Valve (Field Supplied)

*When 2 nozzle sizes are listed, the smaller nozzle should be located on the upper distributor.

NOTE: Factory-supplied distributors have factory-selected nozzle sizes as shown. If necessary, replace factory-supplied nozzles with field-supplied and field-installed nozzles. Consult **AHUBuilder®** software selection program for correct nozzle selection.

Direct-Expansion Circuiting Data — Large Face Area Coils (cont)

CIRCUITING TYPE	96W				110W			
	Full		Double		Full		Double	
Airflow (cfm) at 500 fpm	48,125				55,000			
Total Face Area (sq ft)	96.3				110.0			
Tubes in Face	44	44	44	44	44	44	44	44
Tube Length (in.)	126	126	126	126	144	144	144	144
No. of Circuits - Total	44	44	88	88	44	44	88	88
4-Row Coil	Upper	Lower	Upper	Lower	Upper	Lower	Upper	Lower
Face Split Coils								
No. of TXVs	4	4	—	—	4	4	—	—
Suction Connections (in. OD)	1-3/8	1-3/8	—	—	1-3/8	1-3/8	—	—
Distributor Connections (in. OD)	1-1/8	1-1/8	—	—	1-1/8	1-1/8	—	—
Distributor Nozzle Size	E-12	E-12	—	—	E-12	E-12	—	—
Intertwined Row Split Coils								
No. of TXVs	4	4	—	—	4	4	—	—
Suction Connections (in. OD)	1-3/8	1-3/8	—	—	1-3/8	1-3/8	—	—
Distributor Connections (in. OD)	1-1/8	1-1/8	—	—	1-1/8	1-1/8	—	—
Distributor Nozzle Size	E-12	E-12	—	—	E-12	E-12	—	—
Single Circuit Coils								
No. of TXVs	—	—	—	—	—	—	—	—
Suction Connections (in. OD)	—	—	—	—	—	—	—	—
Distributor Connections (in. OD)	—	—	—	—	—	—	—	—
Distributor Nozzle Size	—	—	—	—	—	—	—	—
6-Row Coil								
Face Split Coils								
No. of TXVs	4	4	—	—	4	4	—	—
Suction Connections (in. OD)	1-3/8	1-3/8	—	—	1-3/8	1-3/8	—	—
Distributor Connections (in. OD)	1-1/8	1-1/8	—	—	1-1/8	1-1/8	—	—
Distributor Nozzle Size	E-12	E-12	—	—	E-12	E-12	—	—
Intertwined Row Split Coils								
No. of TXVs	4	4	—	—	4	4	—	—
Suction Connections (in. OD)	1-3/8	1-3/8	—	—	1-3/8	1-3/8	—	—
Distributor Connections (in. OD)	1-1/8	1-1/8	—	—	1-1/8	1-1/8	—	—
Distributor Nozzle Size	E-12	E-12	—	—	E-12	E-12	—	—
Single Circuit Coils								
No. of TXVs	—	—	—	—	—	—	—	—
Suction Connections (in. OD)	—	—	—	—	—	—	—	—
Distributor Connections (in. OD)	—	—	—	—	—	—	—	—
Distributor Nozzle Size	—	—	—	—	—	—	—	—
8-Row Coil								
Face Split Coils								
No. of TXVs	4	4	8	8	4	4	8	8
Suction Connections (in. OD)	1-3/8	1-3/8	1-3/8	1-3/8	1-3/8	1-3/8	1-3/8	1-3/8
Distributor Connections (in. OD)	1-1/8	1-1/8	1-1/8	1-1/8	1-1/8	1-1/8	1-1/8	1-1/8
Distributor Nozzle Size	E-12	E-12	E-12	E-12	E-12	E-12	E-12	E-12
Intertwined Row Split Coils								
No. of TXVs	4	4	8	8	4	4	8	8
Suction Connections (in. OD)	1-3/8	1-3/8	1-3/8	1-3/8	1-3/8	1-3/8	1-3/8	1-3/8
Distributor Connections (in. OD)	1-1/8	1-1/8	1-1/8	1-1/8	1-1/8	1-1/8	1-1/8	1-1/8
Distributor Nozzle Size	E-12	E-12	E-12	E-12	E-12	E-12	E-12	E-12
Single Circuit Coils								
No. of TXVs	—	—	—	—	—	—	—	—
Suction Connections (in. OD)	—	—	—	—	—	—	—	—
Distributor Connections (in. OD)	—	—	—	—	—	—	—	—
Distributor Nozzle Size	—	—	—	—	—	—	—	—

LEGEND

TXV — Thermostatic Expansion Valve (Field Supplied)

*When 2 nozzle sizes are listed, the smaller nozzle should be located on the upper distributor.

NOTE: Factory-supplied distributors have factory-selected nozzle sizes as shown. If necessary, replace factory-supplied nozzles with field-supplied and field-installed nozzles. Consult **AHUBuilder®** software selection program for correct nozzle selection.

Coil Data (03W - 25T)

39M UNIT SIZE	03W	06W	07T	08W	09T	10W	11T	12W	12T	14W	16T	17W	18T	21W	22T	25W	25T
1/2-in. CHILLED WATER/DIRECT EXPANSION																	
Large Face Area																	
Nominal Capacity (cfm) at 500 fpm	1,736	2,951	3,837	3,819	4,531	4,965	5,833	6,319	6,380	7,170	7,587	8,464	8,898	10,720	11,016	12,205	12,335
Lower Coil Height (in.)	25	25	42.5	27.5	45	27.5	52.5	35	52.5	35	30	37.5	32.5	47.5	35	47.5	37.5
Upper Coil Height (in.)	—	—	—	—	—	—	—	—	—	—	27.5	—	30	—	32.5	—	35
Length (in.)	20	34	26	40	29	52	32	52	35	59	38	65	41	65	47	74	49
Total Face Area (sq ft)	3.5	5.9	7.7	7.6	9.1	9.9	11.7	12.6	12.8	14.3	15.2	16.9	17.8	21.4	22.0	24.4	24.7
Medium Face Area																	
Nominal Capacity (cfm) at 500 fpm	1,215	2,066	2,708	2,778	3,524	3,611	4,444	4,965	4,861	6,146	5,938	6,771	7,474	9,028	8,976	10,278	9,358
Lower Coil Height (in.)	17.5	17.5	30	20	35	20	40	27.5	40	30	45	30	52.5	40	55	40	55
Upper Coil Height (in.)	—	—	—	—	—	—	—	—	—	—	—	—	—	—	—	—	—
Length (in.)	20	34	26	40	29	52	32	52	35	59	38	65	41	65	47	74	49
Total Face Area (sq ft)	2.4	4.1	5.4	5.6	7.0	7.2	8.9	9.9	9.7	12.3	11.9	13.5	14.9	18.1	18.0	20.6	18.7
Bypass Face Area (Internal Chilled Water Only)																	
Nominal Capacity (cfm) at 500 fpm	1,042	1,771	2,257	2,431	3,021	3,160	3,889	4,514	4,253	5,122	4,948	6,207	5,694	7,899	6,936	8,993	8,082
Lower Coil Height (in.)	15	15	25	17.5	30	17.5	35	25	35	25	37.5	27.5	40	35	42.5	35	47.5
Upper Coil Height (in.)	—	—	—	—	—	—	—	—	—	—	—	—	—	—	—	—	—
Length (in.)	20	34	26	40	29	52	32	52	35	59	38	65	41	65	47	74	49
Total Face Area (sq ft)	2.1	3.5	4.5	4.9	6.0	6.3	7.8	9.0	8.5	10.2	9.9	12.4	11.4	15.8	13.9	18.0	16.2
1/2-in. HOT WATER HEATING																	
Large Face Area																	
Nominal Capacity (cfm) at 700 fpm	2,431	4,132	5,372	5,347	6,344	6,951	8,167	8,847	8,932	10,038	10,622	11,849	12,457	15,009	15,422	17,087	17,269
Lower Coil Height (in.)	25	25	42.5	27.5	45	27.5	52.5	35	52.5	35	30	37.5	32.5	47.5	35	47.5	37.5
Upper Coil Height (in.)	—	—	—	—	—	—	—	—	—	—	27.5	—	30	—	32.5	—	35
Length (in.)	20	34	26	40	29	52	32	52	35	59	38	65	41	65	47	74	49
Total Face Area (sq ft)	3.5	5.9	7.7	7.6	9.1	9.9	11.7	12.6	12.8	14.3	15.2	16.9	17.8	21.4	22.0	24.4	24.7
Medium Face Area																	
Nominal Capacity (cfm) at 700 fpm	1,701	2,892	3,792	3,889	4,934	5,056	6,222	6,951	6,806	8,604	8,313	9,479	10,464	12,639	12,566	14,389	13,101
Lower Coil Height (in.)	17.5	17.5	30	20	35	20	40	27.5	40	30	45	30	52.5	40	55	40	55
Upper Coil Height (in.)	—	—	—	—	—	—	—	—	—	—	—	—	—	—	—	—	—
Length (in.)	20	34	26	40	29	52	32	52	35	59	38	65	41	65	47	74	49
Total Face Area (sq ft)	2.4	4.1	5.4	5.6	7.0	7.2	8.9	9.9	9.7	12.3	11.9	13.5	14.9	18.1	18.0	20.6	18.7
Small Face Area																	
Nominal Capacity (cfm) at 700 fpm	—	2,479	2,528	2,917	3,524	3,792	4,278	4,424	4,679	5,019	5,542	6,319	6,477	7,109	7,425	8,094	7,741
Height (in.)	—	15	20	15	25	15	27.5	17.5	27.5	17.5	30	20	32.5	22.5	32.5	22.5	32.5
Length (in.)	—	34	26	40	29	52	32	52	35	59	38	65	41	65	47	74	49
Total Face Area (sq ft)	—	3.5	3.6	4.2	5.0	5.4	6.1	6.3	6.7	7.2	7.9	9.0	9.3	10.2	10.6	11.6	11.1
Bypass Face Area (Internal)																	
Nominal Capacity (cfm) at 700 fpm	1,458	2,479	3,160	3,403	4,229	4,424	5,444	6,319	5,955	7,170	6,927	8,689	7,972	11,059	9,710	12,590	11,314
Lower Coil Height (in.)	15	15	25	17.5	30	17.5	35	25	35	25	37.5	27.5	40	35	42.5	35	47.5
Upper Coil Height (in.)	—	—	—	—	—	—	—	—	—	—	—	—	—	—	—	—	—
Length (in.)	20	34	26	40	29	52	32	52	35	59	38	65	41	65	47	74	49
Total Face Area (sq ft)	2.1	3.5	4.5	4.9	6.0	6.3	7.8	9.0	8.5	10.2	9.9	12.4	11.4	15.8	13.9	18.0	16.2

Physical data (cont)



Coil Data (03W - 25T) (cont)

39M UNIT SIZE	03W	06W	07T	08W	09T	10W	11T	12W	12T	14W	16T	17W	18T	21W	22T	25W	25T
5/8-in. CHILLED WATER																	
Large Face Area																	
Nominal Capacity (cfm) at 500 fpm	1,667	2,833	3,521	3,750	4,229	4,875	5,333	5,958	6,198	6,760	7,917	8,125	8,969	10,156	10,771	11,563	12,760
Lower Coil Height (in.)	24	24	39	27	42	27	48	33	51	33	60	36	63	45	66	45	75
Upper Coil Height (in.)	—	—	—	—	—	—	—	—	—	—	—	—	—	—	—	—	—
Length (in.)	20	34	26	40	29	52	32	52	35	59	38	65	41	65	47	74	49
Total Face Area (sq ft)	3.3	5.7	7.0	7.5	8.5	9.8	10.7	11.9	12.4	13.5	15.8	16.3	17.9	20.3	21.5	23.1	25.5
Medium Face Area																	
Nominal Capacity (cfm) at 500 fpm	1,042	1,771	2,979	2,500	3,625	3,250	4,667	4,875	5,104	6,146	6,333	6,771	7,260	8,802	8,813	10,021	10,208
Lower Coil Height (in.)	15	15	33	18	36	18	42	27	42	30	48	30	51	39	54	39	60
Upper Coil Height (in.)	—	—	—	—	—	—	—	—	—	—	—	—	—	—	—	—	—
Length (in.)	20	34	26	40	29	52	32	52	35	59	38	65	41	65	47	74	49
Total Face Area (sq ft)	2.1	3.5	6.0	5.0	7.3	6.5	9.3	9.8	10.2	12.3	12.7	13.5	14.5	17.6	17.6	20.0	20.4
Bypass Face Area (Internal Chilled Water Only)																	
Nominal Capacity (cfm) at 500 fpm	1,042	1,771	2,167	2,083	2,719	2,708	3,333	4,333	4,010	4,917	5,146	6,094	5,552	7,448	6,854	8,479	8,167
Lower Coil Height (in.)	15	15	24	15	27	15	30	24	33	24	39	27	39	33	42	33	48
Upper Coil Height (in.)	—	—	—	—	—	—	—	—	—	—	—	—	—	—	—	—	—
Length (in.)	20	34	26	40	29	52	32	52	35	59	38	65	41	65	47	74	49
Total Face Area (sq ft)	2.1	3.5	4.3	4.2	5.4	5.4	6.7	8.7	8.0	9.8	10.3	12.2	11.1	14.9	13.7	17.0	16.3
5/8-in. HOT WATER HEATING																	
Large Face Area																	
Nominal Capacity (cfm) at 700 fpm	2,333	3,967	4,929	5,250	5,921	6,825	7,467	8,342	8,677	9,465	11,083	11,375	12,556	14,219	15,079	16,188	17,865
Lower Coil Height (in.)	24	24	39	27	42	27	48	33	51	33	60	36	63	45	66	45	75
Upper Coil Height (in.)	—	—	—	—	—	—	—	—	—	—	—	—	—	—	—	—	—
Length (in.)	20	34	26	40	29	52	32	52	35	59	38	65	41	65	47	74	49
Total Face Area (sq ft)	3.3	5.7	7.0	7.5	8.5	9.8	10.7	11.9	12.4	13.5	15.8	16.3	17.9	20.3	21.5	23.1	25.5
Medium Face Area																	
Nominal Capacity (cfm) at 700 fpm	1,458	2,479	4,171	3,500	5,075	4,550	6,533	6,825	7,146	8,604	8,867	9,479	10,165	12,323	12,338	14,029	14,292
Lower Coil Height (in.)	15	15	33	18	36	18	42	27	42	30	48	30	51	39	54	39	60
Upper Coil Height (in.)	—	—	—	—	—	—	—	—	—	—	—	—	—	—	—	—	—
Length (in.)	20	34	26	40	29	52	32	52	35	59	38	65	41	65	47	74	49
Total Face Area (sq ft)	2.1	3.5	6.0	5.0	7.3	6.5	9.3	9.8	10.2	12.3	12.7	13.5	14.5	17.6	17.6	20.0	20.4
Small Face Area																	
Nominal Capacity (cfm) at 700 fpm	—	2,479	2,654	2,917	2,960	3,792	3,733	3,792	4,594	4,302	5,542	5,688	6,577	6,635	8,225	7,554	9,290
Height (in.)	—	15	21	15	21	15	24	15	27	15	30	18	33	21	36	21	39
Length (in.)	—	34	26	40	29	52	32	52	35	59	38	65	41	65	47	74	49
Total Face Area (sq ft)	—	3.5	3.8	4.2	4.2	5.4	5.3	5.4	6.6	6.1	7.9	8.1	9.4	9.5	11.8	10.8	13.3
Bypass Face Area (Internal)																	
Nominal Capacity (cfm) at 700 fpm	1,458	2,479	3,033	2,917	3,806	3,792	4,667	6,067	5,615	6,883	7,204	8,531	7,773	10,427	9,596	11,871	11,433
Lower Coil Height (in.)	15	15	24	15	27	15	30	24	33	24	39	27	39	33	42	33	48
Upper Coil Height (in.)	—	—	—	—	—	—	—	—	—	—	—	—	—	—	—	—	—
Length (in.)	20	34	26	40	29	52	32	52	35	59	38	65	41	65	47	74	49
Total Face Area (sq ft)	2.1	3.5	4.3	4.2	5.4	5.4	6.7	8.7	8.0	9.8	10.3	12.2	11.1	14.9	13.7	17.0	16.3
1-in. STEAM HEATING																	
Large Face Area																	
Nominal Capacity (cfm) at 700 fpm	2,333	3,967	4,929	5,250	5,921	6,825	7,467	8,342	8,677	9,465	11,083	11,375	12,556	14,219	15,079	16,188	17,150
Lower Coil Height (in.)	24	24	39	27	42	27	48	33	51	33	60	36	63	45	66	45	36
Upper Coil Height (in.)	—	—	—	—	—	—	—	—	—	—	—	—	—	—	—	—	36
Length (in.)	20	34	26	40	29	52	32	52	35	59	38	65	41	65	47	74	49
Total Face Area (sq ft)	3.3	5.7	7.0	7.5	8.5	9.8	10.7	11.9	12.4	13.5	15.8	16.3	17.9	20.3	21.5	23.1	24.5
Medium Face Area																	
Nominal Capacity (cfm) at 700 fpm	1,458	2,479	4,171	3,500	5,075	4,550	6,533	6,825	7,146	8,604	8,867	9,479	10,165	12,323	12,338	14,029	14,292
Lower Coil Height (in.)	15	15	33	18	36	18	42	27	42	30	48	30	51	39	54	39	60
Upper Coil Height (in.)	—	—	—	—	—	—	—	—	—	—	—	—	—	—	—	—	—
Length (in.)	20	34	26	40	29	52	32	52	35	59	38	65	41	65	47	74	49
Total Face Area (sq ft)	2.1	3.5	6.0	5.0	7.3	6.5	9.3	9.8	10.2	12.3	12.7	13.5	14.5	17.6	17.6	20.0	20.4
Small Face Area																	
Nominal Capacity (cfm) at 700 fpm	—	2,479	2,654	2,917	3,383	3,792	4,200	3,792	4,594	4,302	5,542	5,688	6,577	6,635	8,225	7,554	9,290
Height (in.)	—	15	21	15	24	15	27	15	27	15	30	18	33	21	36	21	39
Length (in.)	—	34	26	40	29	52	32	52	35	59	38	65	41	65	47	74	49
Total Face Area (sq ft)	—	3.5	3.8	4.2	4.8	5.4	6.0	5.4	6.6	6.1	7.9	8.1	9.4	9.5	11.8	10.8	13.3
Bypass Face Area (Internal)																	
Nominal Capacity (cfm) at 700 fpm	1,458	2,479	3,033	2,917	3,806	3,792	4,667	6,067	5,615	6,883	7,204	8,531	7,773	10,427	9,596	11,871	11,433
Lower Coil Height (in.)	15	15	24	15	27	15	30	24	33	24	39	27	39	33	42	33	48
Upper Coil Height (in.)	—	—	—	—	—	—	—	—	—	—	—	—	—	—	—	—	—
Length (in.)	20	34	26	40	29	52	32	52	35	59	38	65	41	65	47	74	49
Total Face Area (sq ft)	2.1	3.5	4.3	4.2	5.4	5.4	6.7	8.7	8.0	9.8	10.3	12.2	11.1	14.9	13.7	17.0	16.3

Coil Data (03W - 25T) (cont)

39M UNIT SIZE	03W	06W	07T	08W	09T	10W	11T	12W	12T	14W	16T	17W	18T	21W	22T	25W	25T
5/8-in. HOT WATER IFB																	
Integral Face and Bypass																	
Nominal Capacity (cfm)	—	3,000	3,500	4,000	4,500	5,000	5,500	6,000	6,000	7,000	7,500	8,500	8,500	10,500	11,000	12,500	12,500
Coil Height (in.)	—	22.9	45.9	30.6	45.9	30.6	53.6	30.6	53.6	30.6	65	39	68	48	74	48	79
Length (in.)	—	33.0	26.0	39.0	29.0	48.0	32.0	48.0	35.0	54.0	26.4	59.4	26.4	59.4	37.4	59.4	37.4
Total Face Area (sq ft)	—	3.3	5.0	5.7	5.9	7.4	8.0	7.4	9.0	8.5	7.6	9.2	8.1	12.6	13.5	12.6	14.7
5/8-in. STEAM IFB																	
Integral Face and Bypass																	
Nominal Capacity (cfm)	—	3,000	3,500	4,000	4,500	5,000	5,500	6,000	6,000	7,000	7,500	8,500	8,500	10,500	11,000	12,500	12,500
Coil Height (in.)	—	22.9	45.9	30.6	45.9	30.6	53.6	30.6	53.6	30.6	65	39	68	48	74	48	79
Length (in.)	—	33.0	26.0	39.0	29.0	48.0	32.0	48.0	35.0	54.0	26.4	59.4	26.4	59.4	37.4	59.4	79.4
Total Face Area (sq ft)	—	3.3	5.0	5.7	5.9	7.4	8.0	7.4	9.0	8.5	7.6	9.2	8.1	12.6	13.5	12.6	14.7

Coil Data (30W - 110W)

39M UNIT SIZE	30W	30T	35T	36W	37T	40W	42T	50W	51T	58T	61W	72W	85W	96W	110W
1/2-in. CHILLED WATER/DIRECT EXPANSION															
Large Face Area															
Nominal Capacity (cfm) at 500 fpm	15,174	14,852	17,448	18,333	18,438	20,000	20,938	25,278	25,313	28,828	30,694	36,224	42,656	48,125	55,000
Lower Coil Height (in.)	47.5	37.5	37.5	55	45	30	45	35	45	52.5	42.5	50	50	55	55
Upper Coil Height (in.)	—	35	37.5	—	45	30	45	35	45	50	42.5	47.5	47.5	55	55
Length (in.)	92	59	67	96	59	96	67	104	81	81	104	107	126	126	144
Total Face Area (sq ft)	30.3	29.7	34.9	36.7	36.9	40.0	41.9	50.6	50.6	57.7	61.4	72.4	85.3	96.3	110.0
Medium Face Area															
Nominal Capacity (cfm) at 500 fpm	12,778	11,267	13,958	15,000	15,365	18,333	17,448	19,861	21,094	23,906	25,278	29,722	35,000	39,375	45,000
Lower Coil Height (in.)	40	55	30	45	37.5	55	37.5	55	37.5	42.5	35	40	40	45	45
Upper Coil Height (in.)	—	—	30	—	37.5	—	37.5	—	37.5	42.5	35	40	40	45	45
Length (in.)	92	59	67	96	59	96	67	104	81	81	104	107	126	126	144
Total Face Area (sq ft)	25.6	22.5	27.9	30.0	30.7	36.7	34.9	39.7	42.2	47.8	50.6	59.4	70.0	78.8	90.0
Bypass Face Area (Internal Chilled Water Only)															
Nominal Capacity (cfm) at 500 fpm	11,181	9,731	11,632	12,500	12,292	15,000	13,377	16,250	16,172	18,984	19,861	23,220	27,344	30,625	35,000
Lower Coil Height (in.)	35	47.5	50	37.5	30	45	30	45	30	35	55	32.5	32.5	35	35
Upper Coil Height (in.)	—	—	—	—	30	—	27.5	—	27.5	32.5	—	30	30	35	35
Length (in.)	92	59	67	96	59	96	67	104	81	81	104	107	126	126	144
Total Face Area (sq ft)	22.4	19.5	23.3	25.0	24.6	30.0	26.8	32.5	32.3	38.0	39.7	46.4	54.7	61.3	70.0
1/2-in. HOT WATER HEATING															
Large Face Area															
Nominal Capacity (cfm) at 700 fpm	21,243	20,793	24,427	25,667	25,813	28,000	29,313	35,389	35,438	40,359	42,972	50,714	59,719	67,375	77,000
Lower Coil Height (in.)	47.5	37.5	37.5	55	45	30	45	35	45	52.5	42.5	50	50	55	55
Upper Coil Height (in.)	—	35	37.5	—	45	30	45	35	45	50	42.5	47.5	47.5	55	55
Length (in.)	92	59	67	96	59	96	67	104	81	81	104	107	126	126	144
Total Face Area (sq ft)	30.3	29.7	34.9	36.7	36.9	40.0	41.9	50.6	50.6	57.7	61.4	72.4	85.3	96.3	110.0
Medium Face Area															
Nominal Capacity (cfm) at 700 fpm	17,889	15,774	19,542	21,000	21,510	25,667	24,427	27,806	29,531	33,469	35,389	41,611	49,000	55,125	63,000
Lower Coil Height (in.)	40	55	30	45	37.5	55	37.5	55	37.5	42.5	35	40	40	45	45
Upper Coil Height (in.)	—	—	30	—	37.5	—	37.5	—	37.5	42.5	35	40	40	45	45
Length (in.)	92	59	67	96	59	96	67	104	81	81	104	107	126	126	144
Total Face Area (sq ft)	25.6	22.5	27.9	30.0	30.7	36.7	34.9	39.7	42.2	47.8	50.6	59.4	70.0	78.8	90.0
Small Face Area															
Nominal Capacity (cfm) at 700 fpm	10,063	9,321	13,842	14,000	13,623	14,000	16,285	17,694	14,766	20,672	21,486	—	—	—	—
Height (in.)	22.5	32.5	42.5	30	47.5	30	50	35	37.5	52.5	42.5	—	—	—	—
Length (in.)	92	59	67	96	59	96	67	104	81	81	104	—	—	—	—
Total Face Area (sq ft)	14.4	13.3	19.8	20.0	19.5	20.0	23.3	25.3	21.1	29.5	30.7	—	—	—	—
Bypass Face Area (Internal)															
Nominal Capacity (cfm) at 700 fpm	15,653	13,623	16,285	17,500	17,208	21,000	18,727	22,750	22,641	26,578	27,806	32,509	38,281	42,875	49,000
Lower Coil Height (in.)	35	47.5	50	37.5	30	45	30	45	30	35	55	32.5	32.5	35	35
Upper Coil Height (in.)	—	—	—	—	30	—	27.5	—	27.5	32.5	—	30	30	35	35
Length (in.)	92	59	67	96	59	96	67	104	81	81	104	107	126	126	144
Total Face Area (sq ft)	22.4	19.5	23.3	25.0	24.6	30.0	26.8	32.5	32.3	38.0	39.7	46.4	54.7	61.3	70.0

Coil Data (30W - 110W) (cont)

39M UNIT SIZE	30W	30T	35T	36W	37T	40W	42T	50W	51T	58T	61W	72W	85W	96W	110W
5/8-in. CHILLED WATER															
Large Face Area															
Nominal Capacity (cfm) at 500 fpm	14,375	15,365	18,146	18,000	18,438	20,000	20,938	24,917	25,313	28,688	30,333	35,667	42,000	47,250	54,000
Lower Coil Height (in.)	45	75	78	54	45	30	45	36	45	51	42	48	48	54	54
Upper Coil Height (in.)	—	—	—	—	45	30	45	33	45	51	42	48	48	54	54
Length (in.)	92	59	67	96	59	96	67	104	81	81	104	107	126	126	144
Total Face Area (sq ft)	28.8	30.7	36.3	36.0	36.9	40.0	41.9	49.8	50.6	57.4	60.7	71.3	84.0	94.5	108.0
Medium Face Area															
Nominal Capacity (cfm) at 500 fpm	12,458	12,292	14,656	15,000	15,979	18,000	18,146	19,500	21,938	24,469	24,917	28,979	34,125	38,063	43,500
Lower Coil Height (in.)	39	60	63	45	39	54	39	54	39	45	36	39	39	45	45
Upper Coil Height (in.)	—	—	—	—	39	—	39	—	39	42	33	39	39	42	42
Length (in.)	92	59	67	96	59	96	67	104	81	81	104	107	126	126	144
Total Face Area (sq ft)	24.9	24.6	29.3	30.0	32.0	36.0	36.3	39.0	43.9	48.9	49.8	58.0	68.3	76.1	87.0
Bypass Face Area (Internal Chilled Water Only)															
Nominal Capacity (cfm) at 500 fpm	10,542	9,833	11,865	12,000	12,292	15,000	13,958	16,250	16,875	18,563	19,500	23,406	27,563	31,500	36,000
Lower Coil Height (in.)	33	48	51	36	60	45	30	45	30	33	54	33	33	36	36
Upper Coil Height (in.)	—	—	—	—	—	—	30	—	30	33	—	30	30	36	36
Length (in.)	92	59	67	96	59	96	67	104	81	81	104	107	126	126	144
Total Face Area (sq ft)	21.1	19.7	23.7	24.0	24.6	30.0	27.9	32.5	33.8	37.1	39.0	46.8	55.1	63.0	72.0
5/8-in. HOT WATER HEATING															
Large Face Area															
Nominal Capacity (cfm) at 700 fpm	20,125	21,510	25,404	25,200	25,813	28,000	29,313	34,883	35,438	40,163	42,467	49,933	58,800	66,150	75,600
Lower Coil Height (in.)	45	75	78	54	45	30	45	36	45	51	42	48	48	54	54
Upper Coil Height (in.)	—	—	—	—	45	30	45	33	45	51	42	48	48	54	54
Length (in.)	92	59	67	96	59	96	67	104	81	81	104	107	126	126	144
Total Face Area (sq ft)	28.8	30.7	36.3	36.0	36.9	40.0	41.9	49.8	50.6	57.4	60.7	71.3	84.0	94.5	108.0
Medium Face Area															
Nominal Capacity (cfm) at 700 fpm	17,442	17,208	20,519	21,000	22,371	25,200	25,404	27,300	30,713	34,256	34,883	40,571	47,775	53,288	60,900
Lower Coil Height (in.)	39	60	63	45	39	54	39	54	39	45	36	39	39	45	45
Upper Coil Height (in.)	—	—	—	—	39	—	39	—	39	42	33	39	39	42	42
Length (in.)	92	59	67	96	59	96	67	104	81	81	104	107	126	126	144
Total Face Area (sq ft)	24.9	24.6	29.3	30.0	32.0	36.0	36.3	39.0	43.9	48.9	49.8	58.0	68.3	76.1	87.0
Small Face Area															
Nominal Capacity (cfm) at 700 fpm	9,392	11,185	12,702	14,000	14,627	14,000	15,633	16,683	17,719	21,263	21,233	—	—	—	—
Height (in.)	21	39	39	30	51	30	48	33	45	54	42	—	—	—	—
Length (in.)	92	59	67	96	59	96	67	104	81	81	104	—	—	—	—
Total Face Area (sq ft)	13.4	16.0	18.1	20.0	20.9	20.0	22.3	23.8	25.3	30.4	30.3	—	—	—	—
Bypass Face Area (Internal)															
Nominal Capacity (cfm) at 700 fpm	14,758	13,767	16,610	16,800	17,208	21,000	19,542	22,750	23,625	25,988	27,300	32,769	38,588	44,100	50,400
Lower Coil Height (in.)	33	48	51	36	60	45	30	45	30	33	54	33	33	36	36
Upper Coil Height (in.)	—	—	—	—	—	—	30	—	30	33	—	30	30	36	36
Length (in.)	92	59	67	96	59	96	67	104	81	81	104	107	126	126	144
Total Face Area (sq ft)	21.1	19.7	23.7	24.0	24.6	30.0	27.9	32.5	33.8	37.1	39.0	46.8	55.1	63.0	72.0
1-in. STEAM HEATING															
Large Face Area															
Nominal Capacity (cfm) at 700 fpm	20,125	20,650	24,427	25,200	25,813	28,000	29,313	34,883	35,438	40,163	42,467	49,933	58,800	66,150	75,600
Lower Coil Height (in.)	45	36	39	54	45	30	45	36	45	51	42	48	48	54	54
Upper Coil Height (in.)	—	36	36	—	45	30	45	33	45	51	42	48	48	54	54
Length (in.)	92	59	67	96	59	96	67	104	81	81	104	107	126	126	144
Total Face Area (sq ft)	28.8	29.5	34.9	36.0	36.9	40.0	41.9	49.8	50.6	57.4	60.7	71.3	84.0	94.5	108.0
Medium Face Area															
Nominal Capacity (cfm) at 700 fpm	17,442	17,208	20,519	21,000	22,371	25,200	25,404	27,300	30,713	34,256	34,883	40,571	47,775	53,288	60,900
Lower Coil Height (in.)	39	60	63	45	39	54	39	54	39	45	36	39	39	45	45
Upper Coil Height (in.)	—	—	—	—	39	—	39	—	39	42	33	39	39	42	42
Length (in.)	92	59	67	96	59	96	67	104	81	81	104	107	126	126	144
Total Face Area (sq ft)	24.9	24.6	29.3	30.0	32.0	36.0	36.3	39.0	43.9	48.9	49.8	58.0	68.3	76.1	87.0
Small Face Area															
Nominal Capacity (cfm) at 700 fpm	9,392	11,185	13,679	14,000	13,767	14,000	15,633	16,683	17,719	21,263	21,233	—	—	—	—
Height (in.)	21	39	42	30	48	30	48	33	45	54	42	—	—	—	—
Length (in.)	92	59	67	96	59	96	67	104	81	81	104	—	—	—	—
Total Face Area (sq ft)	13.4	16.0	19.5	20.0	19.7	20.0	22.3	23.8	25.3	30.4	30.3	—	—	—	—
Bypass Face Area (Internal)															
Nominal Capacity (cfm) at 700 fpm	14,758	13,767	16,610	16,800	17,208	21,000	19,542	22,750	23,625	25,988	27,300	32,769	38,588	44,100	50,400
Lower Coil Height (in.)	33	48	51	36	60	45	30	45	30	33	54	33	33	36	36
Upper Coil Height (in.)	—	—	—	—	—	—	30	—	30	33	—	30	30	36	36
Length (in.)	92	59	67	96	59	96	67	104	81	81	104	107	126	126	144
Total Face Area (sq ft)	21.1	19.7	23.7	24.0	24.6	30.0	27.9	32.5	33.8	37.1	39.0	46.8	55.1	63.0	72.0

Coil Data (30W - 110W) (cont)

39M UNIT SIZE	30W	30T	35T	36W	37T	40W	42T	50W	51T	58T	61W	72W	85W	96W	110W
5/8-in. HOT WATER IFB															
Integral Face and Bypass															
Nominal Capacity (cfm)	15,000	15,000	18,000	18,000	18,500	20,000	21,500	25,000	25,500	29,000	30,500	36,000	42,500	48,000	55,000
Coil Height (in.)	48	79	82	60	98	66	97	75	97	110	90	102	102	111	111
Length (in.)	81.4	48.4	59.4	81.4	48.4	81.4	59.4	92.4	70.4	70.4	92.4	92.4	114.4	114.4	136.4
Total Face Area (sq ft)	17.6	19.6	25.6	24.1	25.4	27.3	31.3	36.7	37.6	43.5	45.8	53.2	66.5	73.3	88.0
5/8-in. STEAM IFB															
Integral Face and Bypass															
Nominal Capacity (cfm)	15,000	15,000	18,000	18,000	18,500	20,000	21,500	25,000	25,500	29,000	30,500	36,000	42,500	48,000	55,000
Coil Height (in.)	48	79	82	60	98	66	97	75	97	110	90	102	102	111	111
Length (in.)	81.38	48.4	59.4	81.4	48.4	81.4	59.4	92.4	70.4	70.4	92.4	92.4	114.4	114.4	136.4
Total Face Area (sq ft)	17.6	19.6	25.6	24.1	25.4	27.3	31.3	36.7	37.6	43.5	45.8	53.2	66.5	73.3	88.0

1/2-in. Water Coil Connection Sizes (Units 03W - 30W)

FACE AREA	ROWS	CIRCUIT TYPE	39M UNIT SIZE																		
			03W	06W	07T	08W	09T	10W	11T	12W	12T	14W	16T	17W	18T	21W	22T	25W	25T	30W	
			Nozzle Size (in. MPT)																		
LARGE	1, 2	Half/Full	1.5	1.5	1.5	1.5	1.5	1.5	1.5	1.5	1.5	1.5	1.5	1.5	1.5	2.5	2.5	2.5	2.5	2.5	2.5
	4	Half/Full	1.5	1.5	1.5	1.5	1.5	1.5	1.5	1.5	1.5	1.5	1.5	1.5	1.5	2.5	2.5	2.5	2.5	2.5	2.5
		Double	2.5	2.5	2.5	2.5	2.5	2.5	2.5	2.5	2.5	2.5	2.5	2.5	2.5	2.5	2.5	2.5	2.5	2.5	2.5
	6, 8, 10	Half	1.5	1.5	1.5	1.5	1.5	1.5	1.5	1.5	1.5	1.5	2.5	2.5	2.5	2.5	2.5	2.5	2.5	2.5	2.5
		Full	1.5	1.5	1.5	1.5	1.5	1.5	1.5	1.5	1.5	1.5	2.5	2.5	2.5	2.5	2.5	2.5	2.5	2.5	2.5
	Double	2.5	2.5	2.5	2.5	2.5	2.5	2.5	2.5	2.5	2.5	2.5	(2)2.5	3	(2)2.5	3	(2)2.5	3	(2)3	3	3
MEDIUM	1, 2	Half/Full	1.5	1.5	1.5	1.5	1.5	1.5	1.5	1.5	1.5	1.5	1.5	1.5	1.5	1.5	2.5	2.5	2.5	2.5	2.5
	4	Half/Full	1.5	1.5	1.5	1.5	1.5	1.5	1.5	1.5	1.5	1.5	1.5	1.5	1.5	1.5	2.5	2.5	2.5	2.5	2.5
		Double	2.5	2.5	2.5	2.5	2.5	2.5	2.5	2.5	2.5	2.5	2.5	2.5	2.5	2.5	2.5	2.5	2.5	2.5	2.5
	6, 8, 10	Half	1.5	1.5	1.5	1.5	1.5	1.5	1.5	1.5	1.5	1.5	1.5	1.5	1.5	1.5	2.5	2.5	2.5	2.5	2.5
		Full	1.5	1.5	1.5	1.5	1.5	1.5	1.5	1.5	1.5	1.5	1.5	1.5	1.5	1.5	2.5	2.5	2.5	2.5	2.5
	Double	2.5	2.5	2.5	2.5	2.5	2.5	2.5	2.5	2.5	2.5	2.5	3	2.5	3	3	3	3	3	3	3
BYPASS	1, 2	Half/Full	1.5	1.5	1.5	1.5	1.5	1.5	1.5	1.5	1.5	1.5	1.5	1.5	1.5	1.5	1.5	1.5	1.5	1.5	1.5
	4	Half/Full	1.5	1.5	1.5	1.5	1.5	1.5	1.5	1.5	1.5	1.5	1.5	1.5	1.5	1.5	1.5	1.5	1.5	1.5	1.5
		Double	2.5	2.5	2.5	2.5	2.5	2.5	2.5	2.5	2.5	2.5	2.5	2.5	2.5	2.5	2.5	2.5	2.5	2.5	2.5
	6, 8, 10	Half	1.5	1.5	1.5	1.5	1.5	1.5	1.5	1.5	1.5	1.5	1.5	1.5	1.5	1.5	2.5	2.5	2.5	2.5	2.5
		Full	1.5	1.5	1.5	1.5	1.5	1.5	1.5	1.5	1.5	1.5	1.5	1.5	1.5	1.5	2.5	2.5	2.5	2.5	2.5
	Double	2.5	2.5	2.5	2.5	2.5	2.5	2.5	2.5	2.5	2.5	2.5	3	2.5	3	2.5	3	2.5	3	2.5	2.5
SMALL	1, 2	Half/Full	—	1.5	1.5	1.5	1.5	1.5	1.5	1.5	1.5	1.5	1.5	1.5	1.5	1.5	1.5	1.5	1.5	1.5	1.5
	4	Half/Full	—	1.5	1.5	1.5	1.5	1.5	1.5	1.5	1.5	1.5	1.5	1.5	1.5	1.5	1.5	1.5	1.5	1.5	1.5
		Double	2.5	2.5	2.5	2.5	2.5	2.5	2.5	2.5	2.5	2.5	2.5	2.5	2.5	2.5	2.5	2.5	2.5	2.5	2.5

1/2-in. Water Coil Connection Sizes (Units 30T - 110W)

FACE AREA	ROWS	CIRCUIT TYPE	39M UNIT SIZE														
			30T	35T	36W	37T	40W	42T	50W	51T	58T	61W	72W	85W	96W	110W	
			Nozzle Size (in. MPT)														
LARGE	1, 2	Half/Full	2.5	2.5	2.5	2.5	(2)1.5	(2)1.5	(2)1.5	(2)1.5	(2)1.5	(2)1.5	(2)2.5	(2)2.5	(2)2.5	(2)2.5	(2)2.5
	4	Half/Full	2.5	2.5	2.5	2.5	(2)1.5	(2)1.5	(2)1.5	(2)1.5	(2)1.5	(2)1.5	(2)2.5	(2)2.5	(2)2.5	(2)2.5	(2)2.5
		Double	2.5	2.5	2.5	2.5	(2)2.5	(2)2.5	(2)2.5	(2)2.5	(2)2.5	(2)2.5	(2)2.5	(2)2.5	(2)2.5	(2)2.5	(2)2.5
	6, 8, 10	Half	2.5	2.5	2.5	2.5	(2)1.5	(2)2.5	(2)2.5	(2)2.5	(2)2.5	(2)2.5	(2)2.5	(2)2.5	(2)2.5	(2)2.5	(2)2.5
		Full	2.5	3	3	3	(2)1.5	(2)2.5	(2)2.5	(2)2.5	(2)2.5	(2)2.5	(2)2.5	(2)3	(2)3	(2)3	(2)3
	Double	(2)3	(2)3	3	(2)3	(2)2.5	(2)2.5	(2)2.5	(2)2.5	(2)2.5	(2)2.5	(2)2.5	(2)3	(2)3	(2)3	(2)3	(2)3
MEDIUM	1, 2	Half/Full	2.5	2.5	2.5	2.5	2.5	2.5	2.5	2.5	2.5	2.5	(2)1.5	(2)2.5	(2)2.5	(2)2.5	(2)2.5
	4	Half/Full	2.5	2.5	2.5	2.5	2.5	2.5	2.5	2.5	2.5	2.5	(2)1.5	(2)2.5	(2)2.5	(2)2.5	(2)2.5
		Double	2.5	2.5	2.5	2.5	2.5	2.5	2.5	2.5	2.5	2.5	(2)2.5	(2)2.5	(2)2.5	(2)2.5	(2)2.5
	6, 8, 10	Half	2.5	2.5	2.5	2.5	2.5	2.5	2.5	2.5	2.5	2.5	(2)2.5	(2)2.5	(2)2.5	(2)2.5	(2)2.5
		Full	2.5	2.5	2.5	2.5	3	3	3	3	3	3	(2)2.5	(2)2.5	(2)2.5	(2)2.5	(2)2.5
	Double	3	(2)2.5	3	(2)3	3	3	3	3	3	3	(2)2.5	(2)3	(2)3	(2)3	(2)3	(2)3
BYPASS	1, 2	Half/Full	1.5	2.5	2.5	2.5	2.5	2.5	2.5	2.5	2.5	2.5	(2)1.5	(2)1.5	(2)1.5	(2)1.5	
	4	Half/Full	1.5	2.5	2.5	2.5	2.5	2.5	2.5	2.5	2.5	2.5	(2)1.5	(2)1.5	(2)1.5	(2)1.5	
		Double	2.5	2.5	2.5	2.5	2.5	2.5	2.5	2.5	2.5	2.5	(2)2.5	(2)2.5	(2)2.5	(2)2.5	(2)2.5
	6, 8, 10	Half	2.5	2.5	2.5	2.5	2.5	2.5	2.5	2.5	2.5	2.5	(2)2.5	(2)2.5	(2)2.5	(2)2.5	(2)2.5
		Full	2.5	2.5	2.5	2.5	2.5	2.5	2.5	2.5	2.5	2.5	(2)2.5	(2)2.5	(2)2.5	(2)2.5	(2)2.5
	Double	3	3	3	(2)2.5	3	3	3	3	3	3	(2)2.5	(2)2.5	(2)2.5	(2)2.5	(2)2.5	
SMALL	1, 2	Half/Full	1.5	1.5	1.5	1.5	1.5	1.5	1.5	1.5	1.5	1.5	2.5	—	—	—	
	4	Half/Full	1.5	1.5	1.5	1.5	1.5	1.5	1.5	1.5	1.5	1.5	2.5	—	—	—	
		Double	2.5	2.5	2.5	2.5	2.5	2.5	2.5	2.5	2.5	2.5	2.5	—	—	—	—

NOTE: Where 2 pipe sizes are listed, the first number is the upper coil connection size; the second is the lower coil connection size.

5/8-in. Water Coil Connection Sizes (Units 03W - 30W)

FACE AREA	ROWS	CIRCUIT TYPE	39M UNIT SIZE																		
			03W	06W	07T	08W	09T	10W	11T	12W	12T	14W	16T	17W	18T	21W	22T	25W	25T	30W	
			Nozzle Size (in. MPT)																		
LARGE	1	Half	1.5	1.5	1.5	1.5	1.5	1.5	1.5	1.5	1.5	1.5	1.5	1.5	1.5	2	2	2	2	2	
	2	Half	1.5	1.5	1.5	1.5	1.5	1.5	1.5	1.5	1.5	1.5	1.5	1.5	1.5	1.5	2	2	2	2	2
		Full	2	2	2	2	2	2	2	2	2.5	2.5	2.5	2.5	2.5	2.5	2.5	2.5	2.5	2.5	2.5
	4	Half	1.5	1.5	1.5	1.5	1.5	1.5	1.5	1.5	1.5	1.5	1.5	1.5	1.5	1.5	2	2	2	2	2
		Full	2	2	2	2	2	2	2	2	2.5	2.5	2.5	2.5	2.5	2.5	2.5	2.5	2.5	2.5	2.5
	6, 8	Full	2	2	2	2	2	2	2	2	2.5	2.5	2.5	2.5	2.5	2.5	3	3	3	3	3
Double		2.5	2.5	2.5	2.5	2.5	2.5	2.5	2.5	2.5	2.5	2.5	2.5	2.5	2.5	3	3	3	3	3	
MEDIUM	1	Half	1.5	1.5	1.5	1.5	1.5	1.5	1.5	1.5	1.5	1.5	1.5	1.5	1.5	2	2	2	2	2	
	2	Half	1.5	1.5	1.5	1.5	1.5	1.5	1.5	1.5	1.5	1.5	1.5	1.5	1.5	2	2	2	2	2	
		Full	1.5	1.5	2	2	2	2	2	2	2	2.5	2.5	2.5	2.5	2.5	2.5	2.5	2.5	2.5	2.5
	4	Half	1.5	1.5	1.5	1.5	1.5	1.5	1.5	1.5	1.5	1.5	1.5	1.5	1.5	2	2	2	2	2	
		Full	1.5	1.5	2	2	2	2	2	2	2	2.5	2.5	2.5	2.5	2.5	2.5	2.5	2.5	2.5	2.5
	6, 8	Full	1.5	1.5	2	2	2	2	2	2	2	2.5	2.5	2.5	2.5	2.5	2.5	2.5	2.5	2.5	2.5
Double		2.5	2.5	2.5	2.5	2.5	2.5	2.5	2.5	2.5	2.5	2.5	2.5	2.5	2.5	2.5	2.5	2.5	2.5	2.5	
BYPASS	1	Half	1.5	1.5	1.5	1.5	1.5	1.5	1.5	1.5	1.5	1.5	1.5	1.5	1.5	1.5	1.5	1.5	1.5	1.5	
	2	Half	1.5	1.5	1.5	1.5	1.5	1.5	1.5	1.5	1.5	1.5	1.5	1.5	1.5	1.5	1.5	1.5	1.5	1.5	1.5
		Full	1.5	1.5	1.5	1.5	1.5	1.5	1.5	2	2	2	2	2	2	2.5	2.5	2.5	2.5	2.5	
	4	Half	1.5	1.5	1.5	1.5	1.5	1.5	1.5	1.5	1.5	1.5	1.5	1.5	1.5	1.5	1.5	1.5	1.5	1.5	1.5
		Full	1.5	1.5	1.5	1.5	1.5	1.5	1.5	2	2	2	2	2	2	2.5	2.5	2.5	2.5	2.5	
	6, 8	Full	1.5	1.5	1.5	1.5	1.5	1.5	1.5	2	2	2	2	2	2	2.5	2.5	2.5	2.5	2.5	
Double		2.5	2.5	2.5	2.5	2.5	2.5	2.5	2.5	2.5	2.5	2.5	2.5	2.5	2.5	2.5	2.5	2.5	2.5	2.5	
SMALL	1	Half	—	1.5	1.5	1.5	1.5	1.5	1.5	1.5	1.5	1.5	1.5	1.5	1.5	1.5	1.5	1.5	1.5	1.5	
	2	Half	—	1.5	1.5	1.5	1.5	1.5	1.5	1.5	1.5	1.5	1.5	1.5	1.5	1.5	1.5	1.5	1.5	1.5	
		Full	—	1.5	1.5	1.5	1.5	1.5	1.5	1.5	1.5	1.5	1.5	1.5	2	2	2	2	2	2	

5/8-in. Water Coil Connection Sizes (Units 30T - 110W)

FACE AREA	ROWS	CIRCUIT TYPE	39M UNIT SIZE													
			30T	35T	36W	37T	40W	42T	50W	51T	58T	61W	72W	85W	96W	110W
			Nozzle Size (in. MPT)													
LARGE	1	Half	2	2	2	2	(2)1.5	(2)1.5	(2)1.5	(2)1.5	(2)1.5	(2)2	(2)2	(2)2	(2)2	
	2	Half	2	2	2	2	(2)1.5	(2)1.5	(2)1.5	(2)1.5	(2)1.5	(2)2	(2)2	(2)2	(2)2	
		Full	2.5	2.5	2.5	2.5	(2)2	(2)2	(2)2.5	(2)2	(2)2	(2)2.5	(2)2.5	(2)2.5	(2)2.5	
	4	Half	2	2	2	2	(2)1.5	(2)1.5	(2)1.5	(2)1.5	(2)1.5	(2)2	(2)2	(2)2	(2)2	
		Full	2.5	2.5	2.5	2.5	(2)2	(2)2	(2)2.5	(2)2	(2)2	(2)2.5	(2)3	(2)3	(2)3	
	6, 8	Full	3	3	3	3	(2)2	(2)2	(2)2.5	(2)2	(2)2	(2)2.5	(2)4	(2)4	(2)4	
Double		3	3	3	3	(2)2.5	(2)2.5	(2)2.5	(2)2.5	(2)2.5	(2)2.5	(2)4	(2)4	(2)4		
MEDIUM	1	Half	2	2	2	2	2	2	2	2	2	(2)1.5	(2)2	(2)2	(2)2	
	2	Half	2	2	2	2	2	2	2	2	2	(2)1.5	(2)2	(2)2	(2)2	
		Full	2.5	2.5	2.5	2.5	2.5	2.5	2.5	2.5	2.5	2.5	(2)2	(2)2.5	(2)2.5	(2)2.5
	4	Half	2	2	2	2	2	2	2	2	2	(2)1.5	(2)2	(2)2	(2)2	
		Full	2.5	2.5	2.5	2.5	2.5	2.5	2.5	2.5	2.5	2.5	(2)2	(2)3	(2)3	(2)3
	6, 8	Full	2.5	3	3	3	3	3	3	3	3	3	(2)2.5	(2)3	(2)3	(2)3
Double		2.5	3	3	3	3	3	3	3	3	3	(2)2.5	(2)3	(2)3	(2)3	
BYPASS	1	Half	1.5	1.5	1.5	1.5	2	2	2	2	2	2	(2)1.5	(2)1.5	(2)1.5	(2)1.5
	2	Half	1.5	1.5	1.5	1.5	2	2	2	2	2	2	(2)1.5	(2)1.5	(2)1.5	(2)1.5
		Full	2.5	2.5	2.5	2.5	2.5	2.5	2.5	2.5	2.5	2.5	(2)2.5	(2)2.5	(2)2.5	(2)2.5
	4	Half	1.5	1.5	1.5	1.5	2	2	2	2	2	2	(2)1.5	(2)1.5	(2)1.5	(2)1.5
		Full	2.5	2.5	2.5	2.5	2.5	2.5	2.5	2.5	2.5	2.5	(2)3	(2)3	(2)3	(2)3
	6, 8	Full	2.5	2.5	2.5	2.5	3	3	3	3	3	3	3	2.5/3.0	2.5/3.0	(2)3
Double		2.5	2.5	2.5	2.5	3	3	3	3	3	3	(2)3	(2)3	(2)3	(2)3	
SMALL	1	Half	1.5	1.5	1.5	1.5	1.5	1.5	1.5	1.5	1.5	2	—	—	—	—
	2	Half	1.5	1.5	1.5	1.5	1.5	1.5	1.5	1.5	1.5	2	—	—	—	—
		Full	2	2	2	2	2	2	2	2	2	2	—	—	—	—

NOTE: Where 2 pipe sizes are listed, the first number is the upper coil connection size; the second is the lower coil connection size.

1-in. Steam Coil Connection Sizes (Units 03W - 30W)

FACE AREA	ROWS	CONNECTION	39M UNIT SIZE																	
			03W	06W	07T	08W	09T	10W	11T	12W	12T	14W	16T	17W	18T	21W	22T	25W	25T	30W
			Nozzle Size (in. MPT)																	
ALL	ALL	INLET	2.5	2.5	2.5	2.5	2.5	2.5	2.5	2.5	2.5	2.5	2.5	2.5	2.5	2.5	2.5	2.5	2.5	
		OUTLET	2.5	2.5	2.5	2.5	2.5	2.5	2.5	2.5	2.5	2.5	2.5	2.5	2.5	2.5	2.5	2.5	2.5	

1-in. Steam Coil Connection Sizes (Units 30T - 110W)

FACE AREA	ROWS	CONNECTION	39M UNIT SIZE														
			30T	35T	36W	37T	40W	42T	50W	51T	58T	61W	72W	85W	96W	110W	
			Nozzle Size (in. MPT)														
ALL*	ALL	INLET	2.5	2.5	2.5	2.5	2.5	2.5	2.5	2.5	2.5	2.5	2.5	(2)2.5	(2)2.5	(2)2.5	(2)2.5
		OUTLET	2.5	2.5	2.5	2.5	2.5	2.5	2.5	2.5	2.5	2.5	2.5	2.5	(2)2.5	(2)2.5	(2)2.5

*Large face area sizes 40, 50 and 61 and medium face area size 61 units have 2 sets of steam coil connections.

Hot Water — Integral Face and Bypass Coil Connection Sizes (Units 03W - 30W)

ROWS	CONNECTION	39M UNIT SIZE																	
		03W	06W	07T	08W	09T	10W	11T	12W	12T	14W	16T	17W	18T	21W	22T	25W	25T	30W
		Nozzle Size (in. MPT)																	
1	Inlet	—	2.5	2.5	2.5	2.5	2.5	2.5	2.5	2.5	2.5	2	2	2	2	2	2	2	
	Outlet	—	2.5	2.5	2.5	2.5	2.5	2.5	2.5	2.5	2.5	2	2	2	2	2	2	2	
2	Inlet	—	2.5	2.5	2.5	2.5	2.5	2.5	2.5	2.5	2.5	2	2	2	2	2	2	2.5	
	Outlet	—	2.5	2.5	2.5	2.5	2.5	2.5	2.5	2.5	2.5	2	2	2	2	2	2	2.5	
3	Inlet	—	2.5	2.5	2.5	2.5	2.5	2.5	2.5	2.5	2.5	2	2	2	2	2	2	2.5	
	Outlet	—	2.5	2.5	2.5	2.5	2.5	2.5	2.5	2.5	2.5	2	2	2	2	2	2	2.5	

Hot Water — Integral Face and Bypass Coil Connection Sizes (Units 30T - 110W)

ROWS	CONNECTION	39M UNIT SIZE															
		30T	35T	36W	37T	40W	42T	50W	51T	58T	61W	72W	85W	96W	110W		
		Nozzle Size (in. MPT)															
1	Inlet	2	2	2	2	2	2	2	2	2	2	2	2	2	2	2	2
	Outlet	2	2	2	2	2	2	2	2	2	2	2	2	2	2	2	2
2	Inlet	2	2	2.5	2	2.5	2	2.5	2	2.5	2	2	2.5	2.5	3	3	3
	Outlet	2	2	2.5	2	2.5	2	2.5	2	2.5	2	2	2.5	2.5	3	3	3
3	Inlet	2	2	2.5	2	2.5	2	2.5	2	2.5	2	2	2.5	2.5	3	3	3
	Outlet	2	2	2.5	2	2.5	2	2.5	2	2.5	2	2	2.5	2.5	3	3	3

Steam — Integral Face and Bypass Coil Connection Sizes (Units 03W - 30W)

ROWS	CONNECTION	39M UNIT SIZE																	
		03W	06W	07T	08W	09T	10W	11T	12W	12T	14W	16T	17W	18T	21W	22T	25W	25T	30W
		Nozzle Size (in. MPT)																	
1	Inlet	—	2.5	2.5	2.5	2.5	2.5	2.5	2.5	2.5	2.5	2.5	2.5	2.5	2.5	2.5	2.5	2.5	
	Outlet	—	2.5	2.5	2.5	2.5	2.5	2.5	2.5	2.5	2.5	2	2	2	2	2	2	2	
2	Inlet	—	2.5	2.5	2.5	2.5	2.5	2.5	2.5	2.5	2.5	2.5	3	2.5	3	2.5	3	2.5	3
	Outlet	—	2.5	2.5	2.5	2.5	2.5	2.5	2.5	2.5	2.5	2	2.5	2	2.5	2	2.5	2	2.5
3	Inlet	—	2.5	2.5	2.5	2.5	2.5	2.5	2.5	2.5	2.5	2.5	3	2.5	3	2.5	3	2.5	3
	Outlet	—	2.5	2.5	2.5	2.5	2.5	2.5	2.5	2.5	2.5	2	2.5	2	2.5	2	2.5	2	2.5

Steam — Integral Face and Bypass Coil Connection Sizes (Units 30T - 110W)

ROWS	CONNECTION	39M UNIT SIZE															
		30T	35T	36W	37T	40W	42T	50W	51T	58T	61W	72W	85W	96W	110W		
		Nozzle Size (in. MPT)															
1	Inlet	2.5	2.5	2.5	2.5	2.5	2.5	2.5	3	2.5	2.5	2.5	3	3	3	3	3
	Outlet	2	2	2	2	2	2	2	2.5	2	2	2	2.5	2.5	2.5	2.5	2.5
2	Inlet	2.5	3	3	2.5	3	3	3	3	3	3	3	3	4	4	4	4
	Outlet	2	2.5	2.5	2	2	2.5	2.5	2.5	2.5	2.5	2.5	2.5	3	3	3	3
3	Inlet	2.5	3	3	2.5	3	3	3	3	3	3	3	3	4	4	4	4
	Outlet	2	2.5	2.5	2	2.5	2.5	2.5	2.5	2.5	2.5	2.5	2.5	3	3	3	3

Operating Charge (Approximate) — Direct-Expansion Coil (03W - 30W)

ROWS	CONNECTION	39M UNIT SIZE																	
		03W	06W	07T	08W	09T	10W	11T	12W	12T	14W	16T	17W	18T	21W	22T	25W	25T	30W
		Refrigerant R-32 or R-454B (lb)																	
4	Large	1	3	3	4	4	4	5	5	5	6	7	7	8	9	10	11	11	13
	Medium	1	2	2	3	3	3	4	4	4	5	5	6	6	7	7	8	8	10
6	Large	2	4	5	6	7	7	8	9	9	10	12	12	13	15	16	18	18	22
	Medium	2	3	4	4	5	5	6	7	7	8	9	9	10	11	12	14	14	16
8	Large	3	6	7	8	9	10	11	12	12	15	17	18	19	22	23	26	26	31
	Medium	2	5	5	6	7	8	9	9	9	11	12	13	14	16	17	20	20	23

Operating Charge (Approximate) — Direct-Expansion Coil (30T - 110W)

ROWS	CONNECTION	39M UNIT SIZE													
		30T	35T	36W	37T	40W	42T	50W	51T	58T	61W	72W	85W	96W	110W
		Refrigerant R-32 or R-454B (lb)													
4	Large	13	15	16	16	18	18	22	22	26	27	32	37	42	48
	Medium	10	12	12	12	13	14	17	17	19	20	24	28	32	36
6	Large	22	26	26	27	29	31	37	37	42	45	53	62	70	80
	Medium	16	19	20	20	22	23	27	28	32	33	39	47	53	60
8	Large	31	36	37	38	42	44	52	53	60	63	75	88	100	114
	Medium	23	27	28	29	31	33	39	40	45	48	56	66	75	86

Coil Volume 03W - 25W (Gal. Water)

39M UNIT SIZE	03W	06W	07T	08W	09T	10W	11T	12W	12T	14W	16T	17W	18T	21W	22T	25W
CHILLED WATER																
Large Face Area																
4-Row	1.4	2.2	2.9	2.8	3.4	3.7	4.4	4.7	4.8	5.3	5.7	6.2	6.6	7.8	8.1	8.9
6-Row	2.0	3.3	4.4	4.3	5.1	5.5	6.6	7.0	7.2	7.9	8.5	9.3	9.9	11.8	12.2	13.3
8-Row	2.7	4.4	5.8	5.7	6.9	7.3	8.8	9.3	9.6	10.5	11.3	12.4	13.2	15.7	16.3	17.8
10-Row	3.4	5.5	7.3	7.1	8.6	9.1	11.0	11.6	11.9	13.1	14.1	15.5	16.5	19.6	20.3	22.2
Medium Face Area																
4-Row	0.9	1.5	2.1	2.1	2.7	2.7	3.3	3.7	3.6	4.5	4.4	4.9	5.6	6.6	6.6	7.5
6-Row	1.4	2.3	3.1	3.1	4.0	4.0	5.0	5.5	5.5	6.8	6.6	7.4	8.3	9.9	9.9	11.2
8-Row	1.9	3.1	4.1	4.1	5.3	5.3	6.7	7.3	7.3	9.0	8.9	9.9	11.1	13.2	13.3	15.0
10-Row	2.4	3.9	5.2	5.2	6.7	6.6	8.4	9.1	9.1	11.3	11.1	12.4	13.9	16.5	16.6	18.7
Small Face Area																
4-Row	—	1.3	1.4	1.5	1.9	2.0	2.3	2.3	2.5	2.6	3.0	3.3	3.4	3.7	3.9	4.2
Bypass Face Area																
4-Row	0.8	1.3	1.7	1.8	2.3	2.3	2.9	3.3	3.2	3.8	3.7	4.5	4.2	5.8	5.1	6.5
6-Row	1.2	2.0	2.6	2.7	3.4	3.5	4.4	5.0	4.8	5.6	5.5	6.8	6.3	8.7	7.7	9.8
8-Row	1.6	2.7	3.4	3.6	4.6	4.7	5.9	6.6	6.4	7.5	7.4	9.1	8.5	11.5	10.2	13.1
10-Row	2.0	3.3	4.3	4.5	5.7	5.8	7.3	8.3	8.0	9.4	9.2	11.3	10.6	14.4	12.8	16.4
HOT WATER																
Large Face Area																
1-Row	0.3	0.6	0.7	0.7	0.9	0.9	1.1	1.2	1.2	1.3	1.4	1.5	1.7	2.0	2.0	2.2
2-Row	0.7	1.1	1.5	1.4	1.7	1.8	2.2	2.3	2.4	2.6	2.8	3.1	3.3	3.9	4.1	4.4
Medium Face Area																
1-Row	0.2	0.4	0.5	0.5	0.7	0.7	0.8	0.9	0.9	1.1	1.1	1.2	1.4	1.6	1.7	1.9
2-Row	0.5	0.8	1.0	1.0	1.3	1.3	1.7	1.8	1.8	2.3	2.2	2.5	2.8	3.3	3.3	3.7
Small Face Area																
1-Row	—	0.3	0.3	0.4	0.5	0.5	0.6	0.6	0.6	0.7	0.7	0.8	0.9	0.9	1.0	1.1
2-Row	—	0.7	0.7	0.8	1.0	1.0	1.1	1.2	1.3	1.3	1.5	1.6	1.7	1.9	2.0	2.1
Bypass Face Area																
1-Row	0.2	0.3	0.4	0.5	0.6	0.6	0.7	0.8	0.8	0.9	0.9	1.1	1.1	1.4	1.0	1.6
2-Row	0.4	0.7	0.9	0.9	1.1	1.2	1.5	1.7	1.6	1.9	1.8	2.3	2.1	2.9	2.0	3.3
Integral Bypass Face Area																
1-Row	—	0.3	0.4	0.5	0.5	0.6	0.6	0.6	0.7	0.7	0.5	0.6	0.5	0.8	0.9	0.8
2-Row	—	0.6	0.8	0.9	0.9	1.2	1.3	1.2	1.4	1.4	1.0	1.2	1.1	1.7	1.8	1.7
3-Row	—	0.8	1.2	1.4	1.4	1.8	1.9	1.8	2.1	2.0	1.5	1.9	1.6	2.5	2.6	2.5

NOTE: One gallon of water weighs 8.33 lb.

Coil Volume 25T - 110W (Gal. Water)

39M UNIT SIZE	25T	30W	30T	35T	36W	37T	40W	42T	50W	51T	58T	61W	72W	85W	96W	110W
CHILLED WATER																
Large Face Area																
4-Row	9.1	11.0	10.9	12.7	13.3	13.9	14.5	15.3	18.3	18.4	20.9	22.2	26.2	30.7	34.7	39.6
6-Row	13.6	16.5	16.3	19.1	19.9	20.8	21.7	22.9	27.4	27.6	31.4	33.3	39.3	46.1	52.0	59.3
8-Row	18.2	22.0	21.8	25.5	26.5	27.8	29.0	30.6	36.5	36.8	41.9	44.4	52.3	61.5	69.3	79.1
10-Row	22.7	27.5	27.2	31.8	33.2	34.7	36.2	38.2	45.7	46.0	52.4	55.5	65.4	76.8	86.7	98.9
Medium Face Area																
4-Row	6.9	9.3	8.3	10.2	10.9	11.3	13.3	12.7	14.4	15.3	17.4	18.3	21.5	25.2	28.4	32.4
6-Row	10.4	13.9	12.4	15.3	16.3	16.9	19.9	19.1	21.5	23.0	26.1	27.4	32.2	37.8	42.6	48.5
8-Row	13.8	18.5	16.5	20.4	21.7	22.5	26.5	25.5	28.7	30.7	34.7	36.5	42.9	50.4	56.7	64.7
10-Row	17.7	23.1	20.6	25.5	27.1	28.1	33.2	31.8	35.9	38.3	43.4	45.7	53.7	63.0	70.9	80.9
Small Face Area																
4-Row	4.1	5.2	4.9	7.2	7.2	7.1	7.2	8.5	9.1	7.7	10.7	11.1	—	—	—	—
Bypass Face Area																
4-Row	6.0	8.1	7.1	8.5	9.0	9.0	10.9	9.8	11.7	11.7	13.8	14.4	16.8	19.7	22.1	25.2
6-Row	8.9	12.2	10.7	12.7	13.6	13.5	16.3	14.6	17.6	17.6	20.7	21.5	25.2	29.6	33.1	37.8
8-Row	11.9	16.2	14.3	17.0	18.1	18.0	21.7	19.5	23.5	23.5	27.6	28.7	33.6	39.4	44.1	50.3
10-Row	14.9	20.3	17.8	21.2	22.6	22.5	27.1	24.4	29.4	29.4	34.5	35.9	41.9	49.3	55.2	62.9
HOT WATER																
Large Face Area																
1-Row	2.3	2.7	2.7	3.2	3.3	3.5	3.6	3.8	4.6	4.6	5.2	5.5	6.5	7.7	8.7	9.9
2-Row	4.5	5.5	5.4	6.4	6.6	6.9	7.2	7.6	9.1	9.2	10.5	11.1	13.1	15.4	17.3	19.8
Medium Face Area																
1-Row	1.7	2.3	2.1	2.5	2.7	2.8	3.3	3.2	3.6	3.8	4.3	4.6	5.4	6.3	7.1	8.1
2-Row	3.5	4.6	4.1	5.1	5.4	5.6	6.6	6.4	7.2	7.7	8.7	9.1	10.7	12.6	14.2	16.2
Small Face Area																
1-Row	1.0	1.3	1.2	1.8	1.8	1.8	1.8	2.1	2.3	1.9	2.7	2.8	—	—	—	—
2-Row	2.0	2.6	2.4	3.6	3.6	3.6	3.6	4.2	4.6	3.8	5.4	5.5	—	—	—	—
Bypass Face Area																
1-Row	1.5	2.0	1.8	2.1	2.3	2.3	2.7	2.4	2.9	2.9	3.4	3.6	4.2	4.9	5.5	6.3
2-Row	3.0	4.1	3.6	4.2	4.5	4.5	5.4	4.9	5.9	5.9	6.9	7.2	8.4	9.9	11.0	12.6
Integral Bypass Face Area																
1-Row	1.0	1.2	1.3	1.7	1.6	1.6	1.8	2.0	2.4	2.4	2.8	3.0	3.4	4.3	4.7	5.6
2-Row	1.9	2.3	2.5	3.3	3.2	3.3	3.6	4.0	4.8	4.8	5.6	5.9	6.8	8.5	9.4	11.3
3-Row	2.9	3.5	3.8	5.0	4.7	4.9	5.3	6.0	7.1	7.3	8.4	8.9	10.3	12.8	14.1	16.9

NOTE: One gallon of water weighs 8.33 lb.

Dry Coil Weights (lb) - Sizes 03W-25W

COIL TYPE	FACE AREA	ROWS	FPI	39M UNIT SIZE																
				03W	06W	07T	08W	09T	10W	11T	12W	12T	14W	16T	17W	18T	21W	22T	25W	
CHILLED WATER OR DIRECT EXPANSION	Large	4	8	50	85	111	110	131	143	168	182	184	207	219	244	256	309	317	353	
			11	52	89	115	115	136	149	175	190	191	215	228	254	267	322	330	367	
			14	54	92	120	119	141	155	182	197	199	224	237	264	278	335	344	382	
		6	8	70	120	155	154	183	200	235	255	257	289	306	341	359	432	444	494	
			11	73	124	161	160	190	209	245	265	268	301	319	355	374	450	463	514	
			14	76	129	168	167	198	217	255	276	279	313	331	370	389	468	481	535	
		8	8	90	154	199	198	235	258	302	328	331	372	393	439	461	556	571	635	
			11	94	160	207	206	245	268	315	341	345	387	410	457	480	579	595	661	
			14	98	166	215	215	254	279	328	355	358	403	426	475	500	602	619	688	
		10	8	107	182	236	235	278	305	358	388	392	441	466	520	547	659	677	753	
			11	111	190	246	244	290	318	373	404	408	459	486	542	569	686	705	784	
			14	116	197	255	254	302	331	388	421	425	477	505	563	592	714	733	815	
	Medium	4	8	35	60	78	80	102	104	128	143	140	177	171	195	215	260	259	296	
			11	36	62	81	83	106	108	133	149	146	184	178	203	224	271	269	308	
			14	38	64	85	87	110	113	139	155	152	192	185	211	233	282	280	321	
		6	8	49	83	109	112	142	146	179	200	196	248	239	273	301	364	362	414	
			11	51	87	114	117	148	152	187	209	204	258	249	284	314	379	377	432	
			14	53	90	118	121	154	158	194	217	212	268	259	296	326	394	392	449	
		8	8	63	107	140	144	183	187	230	257	252	319	308	351	387	468	465	533	
			11	66	112	146	150	190	195	240	268	263	332	321	366	404	488	485	555	
			14	68	116	152	156	198	203	250	279	273	345	333	380	420	507	504	577	
		10	8	75	127	166	171	217	222	273	305	299	378	365	416	459	555	551	631	
			11	78	132	173	178	226	231	284	318	311	393	380	433	478	578	574	658	
			14	81	138	180	185	235	240	296	330	324	409	395	451	497	601	597	684	
	Small	4	8	—	51	52	60	73	78	88	91	96	103	114	130	133	146	153	167	
			11	—	53	54	63	76	81	92	95	100	108	119	135	139	152	159	173	
			14	—	55	56	65	79	85	95	99	104	112	124	141	144	158	165	180	
	Bypass	4	8	30	51	65	70	87	91	112	130	123	148	143	179	164	228	200	259	
			11	31	53	68	73	91	95	117	135	128	154	148	186	171	237	208	270	
			14	33	55	70	76	94	99	121	141	133	160	154	194	178	246	216	281	
		6	8	42	71	91	98	122	127	157	182	172	207	200	250	230	319	280	363	
			11	44	74	95	102	127	133	163	190	179	215	208	261	239	332	291	378	
			14	46	77	99	106	132	138	170	197	186	224	216	271	249	345	303	393	
		8	8	54	92	117	126	157	164	202	234	221	266	257	322	295	410	360	466	
			11	56	96	122	131	163	171	210	244	230	277	267	335	308	427	375	486	
			14	59	99	127	137	170	177	218	254	239	288	278	349	320	444	390	505	
		10	8	64	109	139	149	186	194	239	277	261	315	304	381	350	485	426	553	
			11	67	113	144	156	193	202	249	289	272	328	317	397	364	506	444	576	
			14	69	118	150	162	201	210	259	300	283	341	329	413	379	526	462	599	
	HOT WATER	Large	1	8	17	28	37	44	48	56	61	61	69	73	81	85	103	106	118	
				11	17	30	38	38	45	50	58	63	64	72	76	85	89	107	110	122
				14	18	31	40	40	47	52	61	66	66	75	79	88	93	112	115	127
			2	8	23	40	52	51	61	67	78	85	86	96	102	114	120	144	148	165
				11	24	41	54	53	63	70	82	88	89	100	106	118	125	150	154	171
				14	25	43	56	56	66	72	85	92	93	104	110	123	130	156	160	178
		Medium	1	8	12	20	26	27	34	35	43	48	47	59	57	65	72	87	86	99
				11	12	21	27	28	35	36	44	50	49	61	59	68	75	90	90	103
				14	13	21	28	29	37	38	46	52	51	64	62	70	78	94	93	107
2			8	16	28	36	37	47	49	60	67	65	83	80	91	100	121	121	138	
			11	17	29	38	39	49	51	62	70	68	86	83	95	105	126	126	144	
			14	18	30	39	40	51	53	65	72	71	89	86	99	109	131	131	150	
Small		1	8	—	17	17	20	24	26	29	30	32	34	38	43	44	49	51	56	
			11	—	18	18	21	25	27	31	32	33	36	40	45	46	51	53	58	
			14	—	18	19	22	26	28	32	33	35	37	41	47	48	53	55	60	
		2	8	—	24	24	28	34	36	41	42	45	48	53	61	62	68	71	78	
			11	—	25	25	29	35	38	43	44	47	50	55	63	65	71	74	81	
			14	—	26	26	30	37	39	44	46	49	52	58	66	67	74	77	84	
Bypass		1	8	10	17	22	23	29	30	37	43	41	49	48	60	55	76	67	86	
			11	10	18	23	24	30	32	39	45	43	51	49	62	57	79	69	90	
			14	11	18	23	25	31	33	40	47	44	53	51	65	59	82	72	94	
		2	8	14	24	30	33	41	42	52	61	57	69	67	83	77	106	93	121	
			11	15	25	32	34	42	44	54	63	60	72	69	87	80	111	97	126	
			14	15	26	33	35	44	46	57	66	62	75	72	90	83	115	101	131	

Dry Coil Weights (lb) - Sizes 03W-25W (cont)

COIL TYPE	FACE AREA	ROWS	FPI	39M UNIT SIZE															
				03W	06W	07T	08W	09T	10W	11T	12W	12T	14W	16T	17W	18T	21W	22T	25W
1-in. IDT STEAM	Large	1	6	23	40	52	51	61	67	78	85	86	96	102	114	120	144	148	165
			9	24	41	54	53	63	70	82	88	89	100	106	118	125	150	154	171
			12	25	43	56	56	66	72	85	92	93	104	110	123	130	156	160	178
	Medium	1	6	16	28	36	37	47	49	60	67	65	83	80	91	100	121	121	138
			9	17	29	38	39	49	51	62	70	68	86	83	95	105	126	126	144
			12	18	30	39	40	51	53	65	72	71	89	86	99	109	131	131	150
	Small	1	6	—	24	24	28	34	36	41	42	45	48	53	61	62	68	71	78
			9	—	25	25	29	35	38	43	44	47	50	55	63	65	71	74	81
			12	—	26	26	30	37	39	44	46	49	52	58	66	67	74	77	84
	Bypass	1	6	14	24	30	33	41	42	52	61	57	69	67	83	77	106	93	121
			9	15	25	32	34	42	44	54	63	60	72	69	87	80	111	97	126
			12	15	26	33	35	44	46	57	66	62	75	72	90	83	115	101	131
HOT WATER AND STEAM	Integral Face and Bypass	1	6	—	146	221	192	240	224	272	224	295	239	400	507	411	587	541	587
			9	—	152	230	200	250	233	283	233	307	249	417	528	428	612	564	612
			12	—	158	239	208	260	242	294	242	319	259	434	550	446	637	587	637
		2	6	—	152	232	202	255	237	290	237	316	254	429	536	442	630	598	630
			9	—	158	242	210	266	247	302	247	329	265	447	559	461	657	623	657
			12	—	164	252	218	277	257	314	257	342	276	466	582	480	684	649	684
		3	6	—	158	245	212	271	251	309	251	338	269	469	585	483	695	658	695
			9	—	165	255	221	282	261	322	261	352	280	489	610	503	724	685	724
			12	—	172	265	230	293	271	335	271	366	291	509	635	524	754	714	754

LEGEND

FPI — Fins Per Inch

IDT — Inner Distributing Tube

NOTES:

- Weights shown include headers and are the sum of two coils where applicable.
- Coils are full length.
- Weights shown are for aluminum fin coils; for copper fin coils, multiply by 1.20.
- Weights shown are for 1/2-in., 0.016 in. wall tubes; for 1/2-in., 0.025-in. wall tubes, multiply by 1.15.
- Weights shown are for 1/2-in., 0.016-in. wall tubes; for 5/8-in., 0.020-in. wall tubes, multiply by 1.15.
- Weights shown are for 1/2-in., 0.016-in. wall tubes; for 5/8-in., 0.035-in. wall tubes, multiply by 1.50.

Dry Coil Weights (lb) Sizes 25T-110W

COIL TYPE	FACE AREA	ROWS	FPI	39M UNIT SIZE															
				25T	30W	30T	35T	36W	37T	40W	42T	50W	51T	58T	61W	72W	85W	96W	110W
CHILLED WATER OR DIRECT EXPANSION	Large	4	8	355	437	428	503	528	531	576	603	728	729	830	884	1043	1229	1386	1584
			11	370	455	446	523	550	553	600	628	758	759	865	921	1087	1280	1444	1650
			14	385	473	463	544	572	575	624	653	789	790	899	958	1130	1331	1502	1716
		6	8	497	612	599	704	739	743	806	844	1019	1021	1162	1238	1461	1720	1940	2218
			11	518	637	624	733	770	774	840	879	1062	1063	1211	1289	1521	1792	2021	2310
			14	539	663	649	762	801	805	874	915	1104	1106	1259	1341	1582	1863	2102	2402
		8	8	639	787	770	905	950	956	1037	1085	1310	1312	1494	1591	1878	2211	2495	2851
			11	666	819	802	942	990	996	1080	1131	1365	1367	1557	1658	1956	2303	2599	2970
			14	693	852	834	980	1030	1035	1123	1176	1420	1422	1619	1724	2034	2396	2703	3089
		10	8	758	932	913	1072	1126	1133	1229	1286	1553	1555	1771	1886	2226	2621	2957	3379
			11	789	971	951	1117	1173	1180	1280	1340	1618	1620	1845	1964	2318	2730	3080	3520
			14	821	1010	989	1161	1220	1227	1331	1394	1682	1685	1919	2043	2411	2839	3203	3661
	Medium	4	8	270	368	325	402	432	443	528	503	572	608	689	728	856	1008	1134	1296
			11	281	383	338	419	450	461	550	523	596	633	717	758	892	1050	1181	1350
			14	292	399	352	436	468	479	572	544	620	658	746	789	927	1092	1229	1404
		6	8	377	515	454	563	605	620	739	704	801	851	964	1019	1198	1411	1588	1814
			11	393	537	473	586	630	645	770	733	834	886	1004	1062	1248	1470	1654	1890
			14	409	558	492	610	655	671	801	762	868	921	1044	1104	1298	1529	1720	1966
		8	8	485	662	584	724	778	797	950	905	1030	1094	1239	1310	1541	1814	2041	2333
			11	505	690	608	754	810	830	990	942	1073	1139	1291	1365	1605	1890	2126	2430
			14	526	718	633	784	842	863	1030	980	1115	1185	1343	1420	1669	1966	2211	2527
		10	8	575	785	692	858	922	944	1126	1072	1220	1296	1469	1553	1826	2150	2419	2765
			11	599	818	721	893	960	983	1173	1117	1271	1350	1530	1618	1902	2240	2520	2880
			14	623	850	750	929	998	1023	1220	1161	1322	1404	1591	1682	1978	2330	2621	2995
	Small	4	8	159	207	192	285	288	280	288	335	364	304	425	442	—	—	—	—
			11	166	216	200	297	300	292	300	349	379	316	443	460	—	—	—	—
			14	173	224	208	308	312	304	312	363	394	329	461	479	—	—	—	—
	Bypass	4	8	233	322	280	335	360	354	432	385	468	466	547	572	669	788	882	1008
			11	242	335	292	349	375	369	450	401	488	485	570	596	697	820	919	1050
			14	252	349	304	363	390	384	468	417	507	505	592	620	724	853	956	1092
		6	8	326	451	392	469	504	496	605	539	655	652	765	801	936	1103	1235	1411
			11	339	470	409	489	525	516	630	562	683	679	797	834	975	1148	1286	1470
			14	353	488	425	508	546	537	655	584	710	706	829	868	1014	1194	1338	1529
		8	8	419	580	504	603	648	637	778	693	842	838	984	1030	1204	1418	1588	1814
			11	436	604	525	628	675	664	810	722	878	873	1025	1073	1254	1477	1654	1890
			14	454	628	546	653	702	690	842	751	913	908	1066	1115	1304	1536	1720	1966
10		8	497	687	598	715	768	755	922	822	998	994	1166	1220	1427	1680	1882	2150	
		11	517	716	623	744	800	787	960	856	1040	1035	1215	1271	1486	1750	1960	2240	
		14	538	744	648	774	832	818	998	890	1082	1076	1264	1322	1546	1820	2038	2330	
HOT WATER	Large	1	8	118	146	143	168	176	177	192	201	243	243	277	295	348	410	462	528
			11	123	152	149	174	183	184	200	209	253	253	288	307	362	427	481	550
			14	128	158	154	181	191	192	208	218	263	263	300	319	377	444	501	572
		2	8	166	204	200	235	246	248	269	281	340	340	387	413	487	573	647	739
			11	173	212	208	244	257	258	280	293	354	354	404	430	507	597	674	770
			14	180	221	216	254	267	268	291	305	368	369	420	447	527	621	701	801
	Medium	1	8	90	123	108	134	144	148	176	168	191	203	230	243	285	336	378	432
			11	94	128	113	140	150	154	183	174	199	211	239	253	297	350	394	450
			14	97	133	117	145	156	160	191	181	207	219	249	263	309	364	410	468
		2	8	126	172	151	188	202	207	246	235	267	284	321	340	399	470	529	605
			11	131	179	158	195	210	215	257	244	278	295	335	354	416	490	551	630
			14	136	186	164	203	218	224	267	254	289	307	348	368	433	510	573	655
	Small	1	8	53	69	64	95	96	93	96	112	121	101	142	147	—	—	—	—
			11	55	72	67	99	100	97	100	116	126	105	148	153	—	—	—	—
			14	58	75	69	103	104	101	104	121	131	110	154	160	—	—	—	—
		2	8	74	97	89	133	134	131	134	156	170	142	198	206	—	—	—	—
			11	77	101	93	138	140	136	140	163	177	148	207	215	—	—	—	—
			14	81	105	97	144	146	142	146	169	184	154	215	223	—	—	—	—
	Bypass	1	8	78	107	93	112	120	118	144	128	156	155	182	191	223	263	294	336
			11	81	112	97	116	125	123	150	134	163	162	190	199	232	273	306	350
			14	84	116	101	121	130	128	156	139	169	168	197	207	241	284	319	364
		2	8	109	150	131	156	168	165	202	180	218	217	255	267	312	368	412	470
			11	113	157	136	163	175	172	210	187	228	226	266	278	325	383	429	490
			14	118	163	142	169	182	179	218	195	237	235	276	289	338	398	446	510

Dry Coil Weights (lb) Sizes 25T-110W (cont)

COIL TYPE	FACE AREA	ROWS	FPI	39M UNIT SIZE															
				25T	30W	30T	35T	36W	37T	40W	42T	50W	51T	58T	61W	72W	85W	96W	110W
1-in. IDT STEAM	Large	1	6	166	204	200	235	246	248	269	281	340	340	387	413	487	573	647	739
			9	173	212	208	244	257	258	280	293	354	354	404	430	507	597	674	770
			12	180	221	216	254	267	268	291	305	368	369	420	447	527	621	701	801
	Medium	1	6	126	172	151	188	202	207	246	235	267	284	321	340	399	470	529	605
			9	131	179	158	195	210	215	257	244	278	295	335	354	416	490	551	630
			12	136	186	164	203	218	224	267	254	289	307	348	368	433	510	573	655
	Small	1	6	74	97	89	133	134	131	134	156	170	142	198	206	—	—	—	—
			9	77	101	93	138	140	136	140	163	177	148	207	215	—	—	—	—
			12	81	105	97	144	146	142	146	169	184	154	215	223	—	—	—	—
	Bypass	1	6	109	150	131	156	168	165	202	180	218	217	255	267	312	368	412	470
			9	113	157	136	163	175	172	210	187	228	226	266	278	325	383	429	490
			12	118	163	142	169	182	179	218	195	237	235	276	289	338	398	446	510
HOT WATER OR STEAM	INTEGRAL FACE AND BYPASS	1	6	565	749	677	811	853	788	906	914	1064	1046	1150	1181	1356	1628	1699	1983
			9	588	780	706	845	889	821	944	952	1108	1090	1198	1230	1412	1695	1769	2066
			12	613	813	735	880	926	855	983	992	1154	1135	1248	1281	1471	1766	1843	2152
		2	6	621	810	752	909	935	885	997	1025	1180	1190	1316	1320	1530	1846	1931	2262
			9	647	844	783	947	974	922	1039	1068	1229	1239	1371	1375	1594	1923	2011	2356
			12	674	879	816	986	1015	960	1082	1112	1280	1291	1428	1432	1660	2003	2095	2454
		3	6	690	899	844	1028	1044	999	1117	1174	1327	1358	1506	1675	1736	2102	2202	2586
			9	719	936	879	1070	1088	1041	1164	1223	1382	1414	1569	1745	1809	2190	2293	2694
			12	749	975	916	1115	1133	1084	1212	1274	1440	1473	1634	1818	1884	2281	2389	2806

LEGEND

FPI — Fins Per Inch
IDT — Inner Distributing Tube

NOTES:

- Weights shown include headers and are the sum of two coils where applicable.
- Coils are full length.
- Weights shown are for aluminum fin coils; for copper fin coils, multiply by 1.20.
- Weights shown are for 1/2-in., 0.016 in. wall tubes; for 1/2-in., 0.025-in. wall tubes, multiply by 1.15.
- Weights shown are for 1/2-in., 0.016-in. wall tubes; for 5/8-in., 0.020-in. wall tubes, multiply by 1.15.
- Weights shown are for 1/2-in., 0.016-in. wall tubes; for 5/8-in., 0.035-in. wall tubes, multiply by 1.50.

Motor Weights (lb)

HP	230/460-3-60		200/400-3-50*		575-3-60	
	ODP	TEFC	ODP	TEFC	ODP	TEFC
1	40	68	29	34	37	60/68
1-1/2	46	66	36	41	48	60/66
2	54	66	41	47	50	65/66
3	87	92	73	62	70	87
5	94	99	102	72	88	89/99
7-1/2	130	158	121	105	89	142/158
10	126	200	139	128	119	154/200
15	217	259	170	210	170	250/259
20	250	290	205	254	212	287/290
25	309	358	273	363	240	394/368
30	300	436	283	414	284	436/436
40	415	661	416†	470†	370	661/661
50	414	686	403†	527†	440	686/686
60	652**	799	545	790†	591	799
75	706**	850**	651†	884†	670	850
100	782**	1475**	1133†	1450†	750	1008†
125	1000**	1600**	1210†	1625†	950	1714†
150	1318**	1773**	—	—	—	—

LEGEND

ODP — Open Drip Proof
TEFC — Totally Enclosed Fan Cooled

*Both ODP and TEFC 50 Hz motors available in standard models only.

†Availability unconfirmed.

**460 volt only.

NOTE: Multiply motor weight by 0.10 to estimate drive weight.

Electrical Data - Premium Efficiency EISA Compliant Motors

ODP T-Frame Motors - 1800 rpm

MOTOR HP	FLA FOR 3-PHASE, 60 HZ VOLTAGES				EFF. (%)	NEMA FRAME
	208	230	460	575		
1	3.1	2.8	1.4	1.1	85.5	143T
1.5	4.6	4.2	2.1	1.7	86.5	145T
2	6.1	5.6	2.8	2.2	86.5	145T
3	8.6	7.8	3.9	3.1	89.5	182T
5	14.3	13.0	6.5	5.2	89.5	184T
7.5	20.8	18.8	9.4	7.5	91.0	213T
10	27.3	24.7	12.4	9.9	91.7	215T
15	39.8	36.0	18.0	14.4	93.0	254T
20	53.1	48.0	24.0	19.2	93.0	256T
25	65.5	59.3	29.6	23.7	93.6	284T
30	77.8	70.4	35.2	28.2	94.1	286T
40	103.8	93.8	46.9	37.5	94.1	324T
50	128.6	116.3	58.2	46.5	94.5	326T
60	152.7	138.1	69.1	55.2	95.0	364T
75	190.9	172.6	86.3	69.1	95.0	365T
100	252.4	228.3	114.1	91.3	95.4	404T
125	—	—	142.7	114.1	95.4	405T
150	—	—	169.8	135.8	95.8	444T

ODP T-Frame Motors - 3600 rpm

MOTOR HP	FLA FOR 3-PHASE, 60 HZ VOLTAGES				EFF. (%)	NEMA FRAME
	208	230	460	575		
1	3.9	3.5	1.8	1.4	77.0	143T
1.5	4.9	4.4	2.2	1.8	84.0	143T
2	6.3	5.7	2.8	2.3	85.5	145T
3	9.4	8.5	4.3	3.4	85.5	145T
5	15.4	13.9	6.9	5.6	86.5	182T
7.5	22.0	19.9	9.9	8.0	88.5	184T
10	28.7	25.9	13.0	10.4	89.5	213T
15	42.4	38.3	19.1	15.3	90.2	215T
20	55.5	50.2	25.1	20.1	91.0	254T
25	68.3	61.8	30.9	24.7	91.7	256T
30	82.0	74.1	37.1	29.6	91.7	284T
40	107.6	97.3	48.7	38.9	92.4	286T
50	132.8	120.1	60.0	48.0	93.0	324T
60	157.3	142.3	71.1	56.9	93.6	326T
75	196.6	177.8	88.9	71.1	93.6	364T
100	262.2	237.1	118.6	94.8	93.6	365T
125	—	—	146.6	117.3	94.1	404T
150	—	—	176.0	140.8	94.1	405T

LEGEND

EFF.	— Efficiency
EISA	— Energy Independence and Security Act of 2007
FLA	— Full Load Amps
NEMA	— National Electrical Manufacturers Association
ODP	— Open Drip Proof
TEFC	— Totally Enclosed Fan Cooled

TEFC T-Frame Motors - 1800 rpm

MOTOR HP	FLA FOR 3-PHASE, 60 HZ VOLTAGES				EFF. (%)	NEMA FRAME
	208	230	460	575		
1	3.1	2.8	1.4	1.1	85.5	143T
1.5	4.6	4.2	2.1	1.7	86.5	145T
2	6.1	5.6	2.8	2.2	86.5	145T
3	8.6	7.8	3.9	3.1	89.5	182T
5	14.3	13.0	6.5	5.2	89.5	184T
7.5	20.5	18.5	9.3	7.4	91.7	213T
10	27.3	24.7	12.4	9.9	91.7	215T
15	40.4	36.5	18.2	14.6	92.4	254T
20	53.1	48.0	24.0	19.2	93.0	256T
25	65.5	59.3	29.6	23.7	93.6	284T
30	78.7	71.1	35.6	28.5	93.6	286T
40	103.8	93.8	46.9	37.5	94.1	324T
50	128.6	116.3	58.2	46.5	94.5	326T
60	152.7	138.1	69.1	55.2	95.0	364T
75	189.3	171.2	85.6	68.5	95.4	365T
100	252.4	228.3	114.1	91.3	95.4	405T
125	—	—	142.7	114.1	95.4	444T
150	—	—	169.8	135.8	95.8	445T

TEFC T-Frame Motors - 3600 rpm

MOTOR HP	FLA FOR 3-PHASE, 60 HZ VOLTAGES				EFF. (%)	NEMA FRAME
	208	230	460	575		
1	3.9	3.5	1.8	1.4	77.0	143T
1.5	4.9	4.4	2.2	1.8	84.0	143T
2	6.3	5.7	2.8	2.3	85.5	145T
3	9.2	8.3	4.2	3.3	86.5	182T
5	14.7	13.3	6.6	5.3	88.5	184T
7.5	21.5	19.5	9.7	7.8	89.5	213T
10	28.2	25.5	12.8	10.2	90.2	215T
15	41.6	37.6	18.8	15.1	91.0	254T
20	55.5	50.2	25.1	20.1	91.0	256T
25	68.3	61.8	30.9	24.7	91.7	284T
30	82.0	74.1	37.1	29.6	91.7	286T
40	107.6	97.3	48.7	38.9	92.4	324T
50	132.8	120.1	60.0	48.0	93.0	326T
60	157.3	142.3	71.1	56.9	93.6	364T
75	196.6	177.8	88.9	71.1	93.6	365T
100	259.4	234.6	117.3	93.8	94.1	405T
125	—	—	143.9	115.1	95.0	444T
150	—	—	172.6	138.1	95.0	445T

NOTES:

1. Approximate motor full load amps listed. Actual motor full load amps can be found on the motor nameplate.
2. Motor voltage and availability is controlled by **AHUBuilder** software.
3. This chart does not apply to Electronically Commutated Motors.

39M Indoor Air Handler Units

HVAC Guide Specifications

Size Range: **1,500 to 60,500 Nominal Cfm**

Carrier Model Number: **39MN — Indoor Unit**

Part 1 — General

1.01 QUALITY ASSURANCE

- A. Manufacturer Qualifications:
Company specializing in manufacturing the products specified in this section with minimum of five years documented experience.
- B. The management system governing the manufacture of this product is ISO (International Organization for Standardization) 9001:2015 certified.
- C. Air-handling unit assembly shall have UL (Underwriters Laboratories) 60335-2-40 certification for safety, including use with electric heat.
- D. Products requiring electric connection shall be listed and classified by cULus as suitable for the purpose specified and indicated.
- E. All coils shall be rated in accordance with AHRI Standard 410, latest edition. Chilled water, hot water, and steam coils shall be certified, in accordance with AHRI Standard 410.
- F. Direct expansion coils shall be designed and tested in accordance with ANSI/ASHRAE (American National Standard Institute/American Society of Heating, Refrigerating and Air-Conditioning Engineers) 15 Safety Code for Mechanical Refrigeration.
- G. Unit performance shall be rated in accordance with AHRI Standard 430 for Central Station Air Handling Unit Supply Fans and subject to verification of rating accuracy by AHRI-sponsored, third party testing.
- H. Units shall meet NFPA (National Fire Protection Association) 90A requirements.

1.02 DELIVERY, STORAGE AND PROTECTION

- A. All indoor units, painted or unpainted, shall be completely shrink-wrapped from the factory for protection during shipment. Tarping of bare units is unacceptable.
- B. Inspect for transportation damage and store in clean dry place and protect from weather and construction traffic. Handle carefully to avoid damage to components, enclosures, and finish.

1.03 START-UP REQUIREMENTS

Do not operate units until ductwork is clean, filters are in place, bearings lubricated, condensate properly trapped, piping connections verified and leak tested, belts aligned and tensioned, all shipping braces have been removed, and fan has been test run under observation.

Part 2 — Products

2.01 GENERAL DESCRIPTION

- A. Units shall ship in the number of sections necessary to meet project requirements and shall ship in as many splits as specified in selection software. Split options as follows:
 1. Shipped in sections — shipping split.
 2. Shipped assembled — base rail break (ship attached).
 3. Shipped assembled — solid base rail.
- B. Unit shall be factory-supplied, central station air handler. The air-handling unit may consist of a fan with the following factory-installed components as indicated on the equipment schedule.
 1. Mixing Box Section:
 - a. No filter tracks.
 - b. With flat filter tracks.
 - c. With angle filter tracks.
 - d. With bag cartridge filter tracks.
 - e. With exhaust air dampers.
 2. Air Mixing Section.
 3. Exhaust Box Section.
 4. Integral Face and Bypass Section:
 - a. With hot water coil.
 - b. With steam coil.
 5. Internal Face and Bypass Damper Section.
 6. External Face and Bypass Damper Section.
 7. Plenum Section:
 - a. With drain pan.
 - b. No drain pan.
 8. Humidifier Section.
 9. Blow-Thru Discharge Plenum.
 - a. With no openings
 - b. With custom discharge openings
 10. Filter Section:
 - a. 2-in. flat filters.
 - b. 4-in. flat filters.
 - c. 4-in. flat filters with 2-in. pre-filters.
 - d. 2-in. angle filters.
 - e. 4-in. angle filters.
 - f. Side loading 12-in. bag/cartridge filters with 2-in. pre-filters.
 - g. Side loading 30-in. bag/cartridge filters with 2-in. pre-filters.
 - h. Face loading bag/cartridge filters without pre-filters. Maximum bag/cartridge filter length is limited to access/plenum sections placed after this section.
 - i. Face loading HEPA (high-efficiency particulate air) bag/cartridge filters without pre-filters.

11. Gas Heating Section.
 12. Coil Section:
 - a. Chilled water coil.
 - b. Direct expansion coil.
 - c. Hot water coil.
 - d. Steam coil.
 - e. Electric coil.
 13. Multi-Zone Cooling/Heating Coil Section:
 - a. With dampers.
 - b. No dampers (for dual duct).
 14. Energy Recovery Wheel Section.
 15. Sound Attenuator Section.
- C. Fan Section:
1. Horizontal draw-thru (supply, return, and exhaust).
 2. Horizontal blow-thru (with integral diffuser on supply fan only).
 3. Plenum fan:
 - a. With custom discharge openings on draw thru supply fans
 - b. With optional exhaust air damper on return fans
 4. Vertical draw-thru.
- ## 2.02 CASING
- A. Construction:
1. Unit shall be constructed of a complete frame with easily removable panels. Removal of any panel shall not affect the structural integrity of the unit.
 2. All units shall be supplied with 14-gauge or heavier, G-90 galvanized steel base rails. Bolt-on legs are NOT acceptable. Perimeter lifting lugs for overhead lifting shall be provided on each shipping section. Slings units in place of lifting lugs shall not be acceptable.
 3. Unit shall be thermally broken to minimize the conduction path from the inside of the casing to the outside.
 4. Casing panels (top, sides, and bottom) shall be constructed of galvanized steel (18 gauge optional), and shall have one of the following exterior finishes as specified:
 - a. Pre-painted with a baked enamel finish passing 500-hour salt spray test (ASTM [American Society of Mechanical Engineers] B-117) for pre-painted steel and 125-hour marine level 1 cohesion test (ASTM G-85.A5) for pre-painted steel.
 - b. Unpainted G-90 galvanized steel.
 5. Casing panels (top, sides, and bottom) shall be constructed of galvanized steel (18 gauge optional), stainless steel, or aluminum and shall have one of the following interior finishes as specified:
 - a. G-90 pre-coated galvanized steel with a silver zeolite antimicrobial material registered by the US EPA (Environmental Protection Agency) for use in HVAC applications.
 - b. Unpainted G-90 galvanized steel.
 - c. Unpainted 304 stainless steel.
 - d. Unpainted 3003-H14 aluminum.
 - e. Option for aluminum diamond treadplate floors.
 6. Casing panels (top, sides, and bottom) shall be one piece, double-wall construction with foam insulation sealed between the inner and outer panels. Panel assemblies shall not carry an R-value of less than 13.
 7. Casing deflection shall not exceed a L/240 ratio when subject to an internal pressure of \pm 8-in. wg and shall exhibit no permanent deformation at \pm 9-in. wg. L is defined as the longest linear panel or cabinet length (measured to AHRI 1350 Cd level 2).
 8. Casing leakage rate shall be less than 1% at 8 in. wg of nominal unit airflow or 50 cfm, whichever is greater. Leakage rate shall be tested and documented on a routine basis on random production units. Optionally, factory witness leak testing and/or test reports shall be available.
 9. Side panels shall be easily removable for access to unit and shall seal against a full perimeter automotive style gasket to ensure a tight seal.
 10. The panel retention system shall comply with UL 60335-2-40 which states all moving parts (for example, fan blades, blower wheels, pulleys, and belts) that, if accidentally contacted, could cause bodily injury, shall be guarded against accidental contact by an enclosure requiring tools for removal.
 11. Accessibility options shall be as follows:
 - a. Hinged, lockable double-wall access door on either side with removable access panel(s) on the other side.
 - b. Hinged, lockable double-wall access doors on both sides.
 - c. Removable double-wall access panels on both sides.
 12. Depending on the options selected and the remaining available space inside each section, the following options may be available:
 - a. Reinforced glass viewports shall be factory-installed on the access panel(s) or door(s) of the section.
 - b. Marine lights shall be factory installed with or without GFCI (ground fault circuit interrupter) convenience outlets.

13. Fan supports, structural members, panels, or flooring shall not be welded, unless aluminum, stainless steel, or other corrosion-resistant material is used. Painted welds on unit exterior steel or galvanized steel are not acceptable.
14. All coil sections shall be doublewall construction with foam insulation sealed between the inner and outer panels. Panel assemblies shall not carry an R-value of less than 13. Single height coil sections shall have removable frame sections to facilitate vertical coil extraction.
15. Blow-thru sections shall have a diffuser plate as an integral part of the fan section.

B. Access Doors:

Access doors shall be one piece, hinged, lockable double-wall construction with foam insulation sealed between the inner and outer panels. Panel assemblies shall not carry an R-value of less than 13.

C. Drain Pans:

Drain pans shall be foam insulated double-wall galvanized steel (18 gauge optional) or stainless steel construction. The pan shall be sloped toward the drain connection. Drain pan shall have 1-1/2-in. MPT connection exiting through the hand side or opposite side of the casing as specified. One drain outlet shall be supplied for each cooling coil section. Drain pan shall allow no standing water and comply with ASHRAE (American Society of Heating, Refrigeration and Air-Conditioning Engineers). Standard 62.1-2010. Where 2 or more coils are stacked in a coil bank, intermediate drain pans shall be provided and the condensate shall be piped to the bottom drain pan. The bottom coil shall not serve as a drain path for the upper coil.

2.03 FANS

A. General:

1. Forward-curved fan sections shall have one double-width double-inlet (DWDI) fan wheel and scroll. They shall be constructed of galvanized steel with baked enamel. They shall be designed for continuous operation at the maximum rated fan speed and motor horsepower. Fans shall have an AMCA class rating corresponding to the static pressure at which the fan is designed to operate (Class I or II). Completed fan assembly shall be dynamically balanced in accordance with AHRI Guideline G and ANSI S2.19 at design operating speed using contract drive and motor if ordered.
2. Airfoil fan sections shall have one DWDI airfoil fan wheel and scroll. Airfoil blades shall be double thickness design constructed of heavy gauge, high strength steel or aluminum continuously welded to the backplate and the spun inlet flange. Entire fan assembly shall be cleaned, primed and painted with alkyd enamel, except for an aluminum fan wheel when supplied. Fans shall have an AMCA class rating corresponding to the static pressure at which the fan is

designed to operate (Class I or II). Completed fan assembly shall be dynamically balanced to minimum grade of G 6.3 per ANSI/AMCA 204 at design operating speed using contract drive and motor if ordered.

3. Direct drive plenum fan sections:

- a. with a NEMA "T" frame motor shall have the option of one, two, four, or six single width single inlet (SWSI) airfoil fan wheel(s). Airfoil blades shall be double thickness design continuously welded to the back plate and the front plate. Fan wheel shall be constructed of aluminum. Airfoil blades shall be aluminum extrusions and shall be top welded to the back plate and front plate of the wheel. Fan wheel shall be dynamically balanced per ISO standard 1940 quality grade G6.3.
- b. with an EC motor shall have the option of single or multiple SWSI backward curved fans. Fan wheel shall be constructed of aluminum. Blades shall be welded to both front and back plates of the wheel. Fan assembly shall be dynamically balanced per ISO standard 1940 quality grade 6.3.

4. Isolated fan assembly vibration shall not exceed 0.248 in. per second when mounted on active isolators. Vibration shall be measured in both vertical and horizontal directions at the specified fan operating speed using specified motor. For testing purposes, accelerometers shall be mounted on the motor near the bearing locations and removed before shipment.

5. All fan sled components shall provide corrosion protection to pass 100-hour salt spray test per ASTM B-117.

6. Fan wheels for all AF, FC, and direct drive PF with NEMA "T" frame motors shall be keyed to the shaft. Fan wheels for direct drive PF with EC motors shall be mounted directly to the rotor of the EC motor. All shall be designed for continuous operation at maximum rated fan speed and motor horsepower. Fan wheels and shafts shall be selected with a maximum operating speed 25% below the first critical.

7. Belt drive fan motor shall be mounted within the fan section casing on slide rails equipped with adjusting screws. Belt drive and direct drive with NEMA "T" frame motors shall be premium efficiency, open drip-proof or totally enclosed fan cooled NEMA (National Electrical Manufacturers Association) Design A or B with size and electrical characteristics as shown on the equipment schedule. Motor shall be mounted on a horizontal flat surface and shall not be supported by the fan or its structural members. All three-phase motors shall have a $\pm 10\%$ voltage utilization range and a 1.15 minimum service factor. Motor shall be compliant with the Energy Independence and Security Act (EISA)

of 2007 where applicable. Single-phase motors shall be available up to and including 5 hp.

8. Direct drive with EC motors shall exceed the minimum efficiency requirements of the ErP Directive for Fans, efficiency class IE4, and specify motor protection according to EN 60529. Motors shall also provide the following: locked rotor protection, phase failure detection, soft start, mains under-voltage detection, over-temperature protection of electronics/motor, and short circuit protection.

B. Performance Ratings:

Supply fan performance shall be rated and certified in accordance with AHRI Standard 430, latest edition.

C. Sound Ratings:

Manufacturer shall submit first through eighth octave sound power for fan discharge and casing radiated sound. Sound ratings shall be tested in accordance with AHRI 260.

D. Mounting:

1. AF, FC, Direct-drive PF with NEMA motor: Fan scroll, wheel, shaft, bearings, drives, and motor shall be mounted on a common base assembly. The base assembly is isolated from the outer casing with factory-installed isolators and rubber vibration absorbent fan discharge seal. A canvas style duct connection between fan discharge and cabinet is not acceptable. Units shall use 2-in. deflection spring isolators.
2. Direct drive PF with EC motor: Fan wheel, inlet plate, inlet ring, and motor and motor supports shall be a common assembly. The assembly is mounted directly to panels on an internal bulk-head wall.

E. Fan Accessories:

1. Forward-curved fans:
 - a. Variable frequency drives with or without bypass.
 - b. Magnetic motor starters.
 - c. Motor disconnects.
 - d. Airflow measuring piezo ring.
 - e. Piezo ring transducer.
 - f. Motor shaft grounding ring.
 - g. Belt guards.
 - h. Inlet screen.
2. Airfoil Fans:
 - a. Variable frequency drives with or without bypass.
 - b. Magnetic motor starters.
 - c. Motor disconnects.
 - d. Airflow measuring piezo ring.
 - e. Piezo ring transducer.

- f. Motor shaft grounding ring.
- g. Belt guards.
- h. Inlet screen.

3. Direct Drive Plenum Fans with NEMA “T” frame motors:

- a. Variable frequency drives.
- b. Motor protection box for motor current protection with a single VFD driving multiple motors.
- c. Airflow measuring piezo ring.
- d. Piezo ring transducer.
- e. Motor shaft grounding ring.
- f. Inlet guard.
- g. Blank off plate.
- h. Backdraft dampers.

Optional backdraft damper blades shall be 6063-T5 extruded aluminum channel with galvanized steel braces and extruded vinyl blade seals. Blades shall be mechanically fastened to axle rod rods rotating in corrosion-resistant, synthetic bearings. Blades open at 0.12 in. wg and are fully open at 0.2 in. wg.

4. Flexible Connection:

The base assembly is isolated from the outer casing with factory-installed isolators and rubber vibration absorbent fan discharge seal. A canvas style duct connection between fan discharge and cabinet is not acceptable.

5. Direct Drive Plenum Fans with EC Motors

- a. Corrosion protection
- b. Inlet guard
- c. Blankoff plate
- d. Backdraft dampers
- e. Control options
 - 1) 0-10 VDC
 - 2) 4-20 mA
 - 3) Modbus
 - 4) BACnet

2.04 BEARINGS AND DRIVES

A. Bearings:

Self-aligning, grease lubricated, anti-friction with lubrication fittings extended to drive side of fan section. Optional grease fittings extended to the exterior of the casing are available. All bearing life calculations shall be done in accordance with ABMA 9 for ball bearings and ABMA 11 for roller bearings.

1. Size 03 to 110 forward-curved fans: Cartridge type bearings for Class I fans. Heavy-duty pillow block type, self-aligning, regreasable ball or roller type bearings selected for a minimum average life (L50) of 200,000 hours or optionally for an (L50) of 500,000 hours.

2. Size 03 to 110 airfoil fans: Heavy-duty pillow block type, self-aligning, regreasable ball or roller type bearings selected for a minimum average life (L50) of 200,000 hours or optionally for an (L50) of 500,000 hours.

B. Shafts:

Fan shafts shall be solid steel, turned, ground, polished and coated with a rust inhibitor.

C. V-Belt Drive:

Drive shall be designed for a minimum 1.2 service factor as standard with a 1.5 service factor option and/or a factory-supplied extra set of belts. Drives shall be fixed pitch with optional variable pitch for motors 15 hp and less. All drives shall be factory mounted, with sheaves aligned and belts properly tensioned.

2.05 COILS

- A. All water, steam and direct expansion (DX) refrigerant coils shall be provided to meet the scheduled performance. All coil performance shall be certified in accordance with AHRI Standard 410. All water and direct expansion coils shall be tested at 450 psig air pressure. Direct expansion coils shall be designed and tested in accordance with ANSI/ASHRAE 15 Safety Code for Mechanical Refrigeration (latest edition). Factory-supplied 1/2-in. OD coils shall be covered under the standard product one-year limited warranty. All steam coils, integral face and bypass coils and 5/8-in. OD coils shall be warranted for a period not in excess of 12 months from their shipment from the manufacturer. Coil epoxy coating shall be covered under a 5-year limited warranty from the date of shipment from the manufacturer.

B. General Fabrication:

1. All water and refrigerant coils shall have minimum 1/2-in. OD copper tubes mechanically expanded into fins to ensure high thermal performance with lower total flow and pumping requirements. Minimum tube wall thickness shall be 0.016 inches. Optional tube wall thickness of 0.025 in. shall be supplied, if specified.
2. Optionally, water coils shall have minimum 5/8-in. OD copper tubes mechanically expanded into fins to ensure high thermal performance with lower total flow and pumping requirements. Minimum tube wall thickness shall be 0.020 inches. Optional tube wall thickness of 0.035 in. shall be supplied, if specified.
3. Aluminum plate fin type with belled collars available from 8 to 14 fins per inch in one fin per inch increments. Optional copper plate fins shall be supplied, if specified. Fin type shall be sine wave construction.
4. Aluminum-finned coils shall be supplied with die-formed casing and tube sheets of mill galvanized steel or stainless steel as specified. Copper-finned coils shall be supplied with stainless steel casing and tube sheets.

C. Hydronic Heating and Cooling Coils:

1. Headers shall be constructed of steel with steel MPT connections. Headers shall have drain and vent connections accessible from the exterior of the unit. Optional non-ferrous headers and red brass MPT connections shall be supplied if specified.
2. Configuration: Coils shall be drainable, with non-trapping circuits. Coils will be suitable for a design working pressure of 300 psig at 200°F.

D. Steam Distribution (Non-Freeze Type) Heating Coils:

1. Headers shall be steel with MPT connections.
2. Inner steam distributing tubes shall be 5/8-in. OD, 0.020 in. wall thickness, located within 1 in. OD, 0.030 in. wall outer condensing tubes. Working pressure shall be 175 psig at 400°F.

E. Integral Face and Bypass Coils:

1. Sizes 03-14 shall have horizontal steam or hot water coils with a tubewall thickness of not less than 0.020 inches. Tubes shall be mechanically expanded into die formed collars formed in aluminum plate type fins.
2. Sizes 17-110 shall have vertical steam or hot water coils with a tubewall thickness of not less than 0.035 inches. Fins shall be spiral edge-wound copper. Tubes shall be free-floating for thermal expansion and contraction without the use of offset bends or floating headers.

F. Refrigerant Coils:

1. Headers shall be constructed of copper with brazed joints.
2. Brass refrigerant distributors and seamless copper distribution tubes shall be factory supplied to ensure uniform flow.
3. Thermal expansion valves (TXV) and nozzles shall be factory installed and piped to the exterior of the casing. Equalizer lines shall be piped internal to the coil header.
4. Suction and liquid line pairs shall be located next to each other for easy circuit identification. A custom label showing TXV size, nozzle size and condensing unit circuit pairing shall be located on the side of the coil section.
5. Standard circuiting selections include:
 - a. Single distributor arrangement for sizes 03-17.
 - b. Row split intertwined multiple distributor arrangement for sizes 03-110.
 - c. Face split multiple distributor arrangement for sizes 03-110.
6. Coils selected with R-32 or R-454B (A2L refrigerants) shall be equipped with a refrigerant leak detection system which will include a dissipation board and refrigerant sensor(s) mounted within the refrigerant coil section and wired back to the motor starting device (if equipped).

7. Submittals must include a DX coil and condensing unit cross plot to show that the coil and condensing unit capacity match at the rated design conditions.

G. Electric Heating Section:

1. The electric heater casing is constructed of galvanized steel. Heater control box access door shall be mounted on the designated hand side of the unit. Element construction as follows:

- a. Open-wire type, 80% nickel, 20% chromium resistance coils, insulated by Steatite bushings and supported in a galvanized steel frame. Bushings shall be recessed into embossed openings and stacked into supporting brackets, spaced no more than 4-in. centers. Thermal cutouts for overtemperature protection shall be provided to meet UL and NEC requirements. Maximum element heating density shall be 55 watts/sq inch.

- 1) Contactor control - electric heaters up through 60 kW shall have 3 stages of control, beyond 60 kW shall have 6 stages of control.
- 2) SCR control - electric heaters up through a maximum of 90 amps are available with full SCR control. The entire heater is modulated to achieve the proportional control based on a 0 to 10 volt DC or 4 to 20 mA control signal.
- 3) Vernier control - the heater has full modulating control of the first circuit of heat, all of which is rated at equal kW increments. There is a minimum of 3 circuits for this type of control. These stage increments are turned on and off by a step controller. As each stage fulfills the demand for heat, the SCR increment is used as a fully modulating filler between stages. This end output is a fully proportional control of the electric heater based on a 0 to 10 volt DC or 4 to 20 mA control signal.

- b. Sheathed type, 80% nickel, 20% chromium resistance coils, suspended in a magnesium oxide insulator fill within a tubular steel sheath/brazed fin assembly. Silicone rubber end seals shall prevent contamination of the interior, and the exterior shall be protected from corrosion by a high temperature aluminum coating. Thermal cutouts for overtemperature protection shall be provided to meet UL and NEC requirements. Maximum element heating density shall be 55 watts/sq inch.

- 1) Contactor control - electric heaters up through 60 kW shall have 3 stages of control, beyond 60 kW shall have 6 stages of control.

2. The manufacturer shall furnish an integral control box containing thermal cutouts, primary control, subcircuit fusing, airflow switch, and fused control transformer.

3. Electric heaters shall be UL listed for zero clearance and shall meet all applicable National Electric Code requirements.

4. Units with electric heat sections shall be listed under UL 60335-2-40 Standard for Safety.

2.06 GAS HEATING SECTION

- A. Indirect fired gas furnace section(s) shall have a minimum thermal efficiency of 81% and incorporate agency listed gas-fired duct furnace(s) per UL, CSA, or ETL for operation on natural or propane gas to the current edition of ANSI Z83.8 or Canadian CSA 2.6 Standard for Gas-Fired Duct Furnaces. Duct furnaces shall be installed on the positive pressure side of the supply fan only.

- B. The duct furnace module(s) shall have:

1. 20 gauge galvanized steel heat exchanger cabinet.
2. 1 in. thick, minimum 1-1/2 lb per cu ft density thermal insulation for the heat exchanger cabinet.
3. Each furnace shall have an induced-draft fan for the removal of flue gases and to keep the heat exchanger at a negative pressure.
4. Air pressure switches to prove air supply for combustion before operation of gas valve.
5. Patented inshot gas burners with integral carryovers.
6. Direct-spark ignition of the gas burners with remote flame sensor to prove carryover across all burners.
7. A listed 24-vac redundant combination gas valve including two electric shutoff valves, gas pressure regulator, and a manual shutoff valve per furnace.
8. An automatic reset type high limit switch to limit maximum outlet air temperature to less than 250°F.

9. Manual reset flame rollout switches.

10. Minimum of one 40 va, 24 vac control transformer.

11. 1/8-in. NPT tapped test gauge connection in the gas manifold for measuring gas pressure.

12. Union fitting downstream of gas control to facilitate installation and service.

13. Provision for attachment of a vent system to exhaust flue gases to the outdoors.

- C. Gas-fired duct furnace(s) provided shall have an 18 gauge tubular heat exchanger assembly suitable to withstand 3.0 in. wg total external static pressure without burner flame disturbance and constructed of either:

1. Type 409 stainless steel (0.044 minimum wall thickness) produced to ASTM A268.
2. Type 304L stainless tubes (0.047 minimum wall thickness) produced to ASTM A249.

- D. Gas heating section modules shall be listed for application downstream of refrigeration and cooling systems and shall provide means for removal of condensate that occurs in the tubes during cooling operation. Heat exchanger tubes shall have (integral formed dimpled restrictors; formed tubulators) to provide for an unobstructed drainage path and tubes shall be formed to provide a positive pitch to promote condensate drainage. Drainage shall be configured so that burners and burner surfaces are not exposed to condensate.
 - E. Gas heating section shall incorporate a direct spark ignition control module listed by one of the following: UL, CSA, or ETL.
 - F. Controls shall provide:
 - 1. 100% safety shutoff.
 - 2. A 15-second minimum pre-purge period prior to trial for ignition.
 - 3. High-energy direct spark ignition of main burners.
 - 4. Electronic flame supervision incorporating a 0.8-second flame failure response time.
 - 5. Up to 2 additional ignition retries preceded by an inter-purge period.
 - 6. A minimum 30-second post-purge.
 - 7. Automatic reset after one hour to initiate additional ignition trials if lockout occurs during heat call.
 - 8. An LED indicator light to provide a flash code to identify the operating condition of the control.
 - G. Gas heating section shall be equipped for operation with 115 vac, single-phase, 60 Hz power supply.
 - H. All electrical components shall be listed or recognized by UL, CSA, or ETL.
 - I. Gas Furnace Control:
 - 1. Single furnace — Operates from 10 to 100% of input from a single analog input of 0 to 10 vdc.
 - 2. Two furnaces in series — Lead unit operates from 20 to 100% of input and secondary unit operates in two-stage operation to achieve overall system input of 10 to 100% from a single analog input of 0 to 10 vdc.
 - 3. Furnace rack systems — Multiple furnaces operate from a single analog input of 0 to 10 vdc with a lead modulating furnace and multiple secondary two-stage furnaces to achieve overall system input of 10 to 100%. (10:1 turndown minimum; most rack systems provide greater than 10:1 turndown.)
 - J. Electronic modulation — Operates from 10 to 100% of input from a single analog input of 0 to 10 vdc. Heat enable contact (supplied by others) initiates and ends heating cycles. Heating unit incorporates two-speed operation of combustion air blower and two-stage gas valve, signal amplifier and timer relay control.
 - K. Gas supply pressure
 - 1. Min gas valve inlet natural gas shall be 6.0 to 13.5 in. wg
 - 2. Min gas valve inlet propane shall be 11.0 to 12.0 in. wg
 - L. Units are orificed for operation up to 2000 ft above sea level unless specified for high altitude operation.
 - M. Duct furnaces shall be test-fired prior to shipment to verify proper ignition, operation and shutdown and satisfactory operation of all components.
 - N. Furnaces shall be provided with printed installation and maintenance instructions, burner operating and maintenance instructions, piping and wiring diagrams and installation start-up data sheet.
- ## 2.07 ENERGY RECOVERY WHEEL
- A. Construction:
 - 1. Wheel sections shall incorporate a rotary wheel in an insulated cassette frame complete with seals, drive motor and drive belt.
 - 2. The wheel shall be coated with silica gel desiccant, permanently bonded without the use of binders or adhesives.
 - 3. The substrate shall be made of a light weight polymer and shall not degrade nor require additional coatings for application in coastal environments.
 - 4. Coated wheel segments shall be washable with detergent or alkaline coil cleaner and water.
 - 5. The silica gel desiccant shall not dissolve nor deliquesce in the presence of water or high humidity.
 - 6. The wheel polymer layers shall be wound continuously with one flat and one structured layer in an ideal parallel plate geometry providing laminar flow and minimum pressure drop.
 - 7. The wheel shall incorporate the channel matrix design and an optional adjustable mechanical purge.
 - 8. The polymer layers shall be captured in a stainless steel wheel frame or aluminum and stainless steel segment frames that provide a rigid and self-supporting matrix.
 - 9. Energy recovery wheels greater than 25 inches in diameter shall be provided with removable wheel segments.
 - 10. Wheel frame shall be a welded hub, spoke and rim assembly of stainless, plated and/or coated steel and shall be self-supporting without the wheel segments in place.
 - 11. Wheel segments shall be removable without tools to facilitate maintenance and cleaning.
 - 12. Wheel bearings shall provide an L-10 life in excess of 400,000 hours.
 - 13. Wheel rim shall be continuous rolled stainless steel and the wheel shall be connected to the shaft by means of taper locks.
 - 14. All diameter and perimeter seals shall be provided as part of the cassette assembly and shall be factory set.

15. Drive belts of stretch urethane shall be provided for wheel rim drive without the need for external tensioners or adjustment.
16. The energy recovery section shall be a UL recognized component for electrical and fire safety. The wheel drive motor shall be UL recognized and mounted in the cassette frame and supplied with a service connector or junction box.
17. Thermal performance shall be AHRI Standard 1060 certified and bear the AHRI Certified Product Seal. Cassettes shall be listed in the AHRI Certified Products Directory and bear the AHRI Certified Product Seal.
18. Wheel shall carry a 5-year parts warranty. This warranty is for all wheel cassette components except the drive motor, which carries the motor manufacturer's warranty.

2.08 HUMIDIFIERS

- A. The humidifiers shall be of the direct discharge type, using steam from existing steam lines or boilers to be injected into the air plenums for humidification.
- B. Each humidifier shall consist of multiple, vertical steam discharge pipes, supported on horizontal header manifolds, spaced to provide the optimum of steam to air contact while minimizing pressure drop. Each humidifier shall be sized to nominally match the air plenum width and height for maximum contact of the discharging steam to the air passing around the vertical steam discharge pipes.
- C. The vertical steam discharge pipes shall be constructed of 316 stainless steel. Each pipe shall have a full-length, inverted slot on each side for steam discharge at 100% air to steam contact. Nozzles and holes have less than 15% air to steam contact and are, therefore, unacceptable.
- D. A full-length stainless steel fishbone shaped baffle shall be used inside the vertical discharge pipe to wick condensate away from the discharge slots and back to the center of the pipe for re-evaporation.
- E. The feeder manifolds shall be constructed of 316 stainless steel, sized to move the steam in a specific mass-flow speed range, for maximum condensate separation. Final condensate separation shall occur inside the feeder manifolds, after the control valve, with the dried steam then injected directly into the vertical discharge pipes.
- F. Insulated uprights provide a cushion of air that reduces both heat gain and condensate formation. Insulated models have nozzles inserted in the uprights to ensure that only dry steam is delivered into the air.
- G. The steam humidifier shall be designed with slip fittings for easy assembly. The steam humidifier shall be designed without plastic nozzles, collars, o-rings or gaskets for zero maintenance.

2.09 FILTER SECTIONS

- A. Flat filter sections shall accept either 2-in. or 4-in. filters. Sections shall include side access slide rails. Optional 6-in. filter racks shall be capable of accepting 4-in. final filters. Optional 2 in. pre-filter shall be available.

- B. Angle filter sections shall accept either 2-in. or 4-in. filters of standard sizes, arranged in a horizontal V formation.
- C. Draw-thru bag/cartridge filter sections shall be capable of accepting headered standard size 6-in. to 12-in. deep rigid media or bag filters and a 2-in. pre-filter.
- D. Draw-thru bag/cartridge filter sections shall be capable of accepting headered standard size 12-in. to 30-in. deep rigid media or bag filters and a 2-in. pre-filter.
- E. Blow-thru bag/cartridge filter sections shall contain a face loading filter frame and be capable of accepting standard size 12-in. deep rigid media (headered or box) or bag filters.
- F. Blow-thru HEPA filter sections shall contain a face loading filter frame and be capable of accepting standard size 12-in. deep HEPA box filters.
- G. Differential Pressure Gauges:

1. Housing shall be constructed of a glass filled nylon case and acrylic lens. Exterior finish shall be coated black.
2. Accuracy shall be $\pm 5\%$ of full scale throughout range at 70°F.
3. Pressure limits shall be 30 psig continuous to either pressure connection.
4. Temperature limits shall be 20 to 120°F.
5. Diameter of dial face shall be 2.33 in.
6. Process connections shall be barbed, 3/16-in. for ID tubing.

2.10 Sound Attenuators:

- A. Factory-supplied sound attenuators (silencers) shall be fabricated from solid and perforated sheet metal. Internal splitters (baffles) shall be filled with acoustic-grade inorganic glass fiber to absorb sound power. Perforated metal faces shall protect the glass fiber from airflow erosion.
- B. Insertion loss sound ratings shall be stated in accordance with AHRI 260, and pressure-drop data shall follow ASTM E477.
- C. Standard Construction Features:
 1. Galvanized casing lock-formed construction in accordance with SMACNA requirements.
 2. 1 inch slip connection provided at each end.
 3. Aerodynamically shaped nose at the inlet to minimize turbulence.
 4. Splitters with a perforated diffuser tail. Acoustic media shall be installed at no less than 15% compression to maintain uniform density.

2.11 DAMPERS

- A. Factory-supplied dampers shall be warranted to be free from defects in material and workmanship for a period of 12 months after being installed or placed in service, but in no instance shall the period of warranty be longer than 18 months from the date of the original shipment by the manufacturer.

- B. Mixing boxes, filter-mixing boxes, and exhaust boxes shall have parallel or opposed blades and interconnecting outside-air and return-air dampers. Bottom damper locations shall be optionally available with a tool screen to prevent most objects from falling through a bottom damper opening.
1. Standard Dampers:
Damper blades shall be constructed of galvanized steel, with blade seals and stainless steel jamb seals. Blades shall be mechanically fastened to axle rods rotating in self-lubricating synthetic bearings. Maximum leakage rate shall be 4 cfm/ft² at 1 in. wg differential pressure.
 2. Premium Dampers:
Damper blades shall be constructed of galvanized steel with a double-skin airfoil design, with blade seals and stainless steel jamb seals. Blades shall be mechanically fastened to axle rods rotating in self-lubricating synthetic bearings. Maximum leakage rate shall be 2 cfm/ft² at 1 in. wg differential pressure.
 3. Outside Air Measurement Dampers:
 - a. Damper frame shall be nominal 4 in. x 1 in. x minimum 0.081 in. and constructed of 6063-T5 extruded aluminum.
 - b. Airflow measuring blades shall be airfoil-shaped, heavy gauge anodized 6063-T5 extruded aluminum and fixed in 10 in. x minimum 16 gauge galvanized steel frame.
 - c. Jamb seals shall be flexible metal compression type along control damper sides.
 - d. Blade seals shall be neoprene along control damper blade edges.
 - e. Bearings shall be molded synthetic.
 - f. Linkage shall be galvanized steel, concealed in frame.
 - g. Axles shall be minimum 1/2-in. diameter plated steel, hex-shaped, mechanically attached to blade.
 - h. Operating temperature shall be -22 to 140°F.
 - i. Air straightener section shall be aluminum alloy honeycomb contained in 5 in. long, 16 gauge galvanized steel sleeve attached to monitoring blade frame.
 - j. Airflow range shall be 400 to 5,000 ft per minute face velocity.
 - k. Maximum leakage rate shall be 2 cfm/ft² at 1 in. wg differential pressure.
- C. Integral Face and Bypass Dampers:
1. Integral face and bypass (IFB) coils shall be capable of maintaining a constant air volume, within 5%, shall be capable of maintaining a constant leaving air temperature as entering air conditions vary, and shall be capable of producing mixed leaving air temperatures within 3 ft downstream with a maximum variance in air temperature of 5°F, regardless of damper position.
2. When no heating is required, dampers shall divert air to bypass around heating surface with minimal temperature override.
 3. Coil casing, dampers and baffles shall be fabricated from galvanized steel with an option for stainless steel. Coils shall be tested at 300 psig.
 4. Integral face and bypass coils shall be provided with a connection point for field-mounted actuator(s), electrical or pneumatic, or can be provided from the factory at an additional cost.
 5. Actuator connection point shall be mechanically attached to dampers via linkage mechanisms. Dampers shall be interconnected for operation simultaneously across each face of coil.
- D. Face and Bypass Dampers:
1. Internal Face and Bypass Dampers:
Internal face and bypass dampers shall be factory mounted in galvanized steel frame. Damper blades shall be constructed of galvanized steel, with high temperature blade and edge seals. Blades shall be mechanically fastened to axle rods rotating in self-lubricating synthetic bearings. To eliminate blade warping, face dampers shall be sectionalized to limit blade length to 60 in. maximum. Face damper blades shall be opposed and arranged to match coil face with top bypass, and internal linkage.
 2. External Face and Bypass Dampers:
Face damper shall be factory mounted in galvanized steel frame. Damper blades shall be constructed of galvanized steel, with high temperature blade and edge seals. Blades shall be mechanically fastened to axle rods rotating in self-lubricating synthetic bearings. Bypass damper shall be constructed of galvanized steel, with blade seals and stainless steel jamb seals. Blades shall be mechanically fastened to axle rod rotating in self-lubricating synthetic bearings. Face damper blades shall be opposed with top bypass, and internally mounted linkage.
- E. Multi-Zone Dampers:
Multi-zone dampers shall be factory mounted in galvanized steel frame. Damper blades shall be constructed of galvanized steel with a double-skin airfoil design, with blade seals and stainless steel jamb seals. Blades shall be mechanically fastened to axle rods rotating in self-lubricating synthetic bearings. Maximum leakage rate shall be 11 cfm/ft² at 1 in. wg differential pressure. Maximum pressure drop due to dampers shall be no more than 0.40 in. wg. Number of zones shall vary by size of section.

F. Smoke Damper:

Smoke Dampers shall be factory mounted only available in the return air opening on mixing boxes and filter-mixing boxes.

1. UL555S Classified.
2. Rated up to 4000 fpm and 8 in. wg.
3. Equipped with a factory-furnished actuator that provides fail-safe operation (the damper automatically moves to the designated fail-safe position when fire interrupts power).
4. Airfoil blades, offering greater strength, lower static pressure, superior sealing, enhanced fire protection, and reduced noise.
5. Horizontal dampers shall be constructed of galvanized steel. Vertical dampers shall also be galvanized steel, except when height exceeds 39 inches, in which case they shall be constructed of aluminum.

2.12 AIR MIXING SECTION

A. KEES Air Mixer^{®1}

Air mixer of 0.081-in. aluminum construction of size, performance and maximum pressure drop indicated. The air mixer shall mix two or more airstreams of differing temperature to within $\pm 6^{\circ}\text{F}$ of theoretical mixed-air temperature and provide a more uniform air velocity contour entering a downstream filter or coil bank.

B. Blender Products Series IV Air Blender^{®1}

Static mixing devices of a minimum 0.080 in. aluminum welded and mechanical fastened construction shall be installed where shown to enhance the mixing of outside air with return air to a desired mixing effectiveness and provide even airflow across filters, coils and control sensors. When combined with a typical mixing box the mixing section shall provide a Mixing Effectiveness of 65% with a minimum outdoor air percentage of 30%. Air mixer models shall be geometrically scaled to ensure proper performance across full range of applications. Mixers that are not geometrically scaled are not acceptable.

2.13 UV-C GERMICIDAL LAMPS

- A. Emitters and fixtures for UV-C lamps shall be designed for use inside an HVAC system and shall be covered by a 1 year warranty. Individual lamp output shall be measured in an ASME nozzled test apparatus using a 45°F airstream moving at not less than 400 fpm. Lamp output at 253.7 nm shall not be less than $10 \mu\text{W}/\text{cm}^2$ per inch of arc length measured at a distance of one meter.
- B. Power supplies for UV-C lamps shall be a high-efficiency electronic type which are matched to the emitters and are capable of producing the specified output intensity with an input power no more than 80 watts.

C. Fixtures for UV-C lamps shall be factory installed and wired to a SPDT disconnect switch and door interlock switches in each door. Fixtures are wired for 120 v/single ph requiring a minimum circuit ampacity of 15 amps. Lamps shall ship separately for field installation to minimize the chance for bulb damage.

D. Emitters and fixtures shall be installed in sufficient quantity and arranged so as to provide an equal distribution of UV-C energy on the coil and drain pan.

E. The minimum UV-C energy striking the leading edge of the coil pan shall be not less than $450 \mu\text{W}/\text{cm}^2$ at the closest point and through placement, not less than 60% of that value at the farthest point. Equal amounts are to strike the drain pan, either directly or indirectly through reflection.

F. Emitters and fixtures shall be installed such that UV-C energy strikes all surfaces of the coil, drain pan, and the available line of sight airstream.

2.14 ELECTRICAL ACCESSORIES:

A. ECM Power Distribution Panel

1. Power distribution panel shall be enclosed in a NEMA 4 electrical box and shall be included with every fan section which has an ECM fan array.
2. A single line of sight disconnect for the entire fan array shall be located on the outside of the electrical box.
3. Individual circuit breakers for each fan shall be mounted on the power distribution panel to isolate each fan for service. Fans shall be factory wired back to the power distribution panel.
4. Control wiring from all fans in the array shall terminate at one point inside the power distribution panel to control the entire array. Control signal shall be wired as 0-10 volt and shall include a field installed resistor if 4-20 mA control is required.
5. BACnet or Modbus shall be available as an option. When selected, all motors shall be factory addressed.
6. A high Short-Circuit Current Rating (SCCR) option is available for ECM fan arrays with 12 or fewer fans:
 - a. 65kA for 460 V systems.
 - b. 100kA for 208-230 V systems.

B. Single Point Power:

The single point power (SPP) box shall have an externally mounted, complete unit line of site disconnect. Internally, the single point power box shall have individual circuit breakers for each circuit, allowing individual circuit protection and a means of disconnect while not completely disabling the unit. SPP box locations shall be offered as:

- a. Single Point Power Right Side Mount
- b. Single Point Power Left Side Mount
- c. Single point Power End Mount

1. Third-party trademarks and logos are the property of their respective owners.

1. Single Point Power Enclosure:
 - a. Enclosure supplied shall have appropriately sized circuit breakers, fusing, wiring, labeling and penetrations based on the unit configuration.
 - b. Enclosure shall be equipped with a lockable door and a NEMA extended rotary handle mechanism on the enclosure door to provide a means for external disconnect operation to the main circuit breaker switch within the SPP enclosure.
 - c. Enclosure to be SCE “EnviroLine” NEMA 4 steel or equivalent.
 - d. Enclosure to be suitable for both indoor and outdoor applications and shall operate within temperature limits of -20°F to $+140^{\circ}\text{F}$.
 - e. All SPP assemblies shall comply with UL 508 and be labeled as compliant.
 - f. Wiring penetrations shall be pre-punched in the back of the enclosure and enter the inside of the air handling unit through strain reliefs. Enclosure shall be gasketed and sealed to the panel it is mounted to.
 - g. A single 120 volt GFCI outlet shall be mounted on the enclosure when at least one marine light, convenience outlet, UV-C section or controls section is selected.
 - h. Internal components (i.e., fuse blocks, circuit breakers) shall be labeled with the appropriate circuit identification.
 - i. Enclosure assemblies supplied with fuses shall have a label affixed that provides replacement fuse identification.
 - j. All enclosures shall have the following labels adhered to the inside of the enclosure door: UL 508 labeling, amperage and voltage rating, maximum overcurrent protection rating.
2. Transformer:
 - a. Single phase resin filled.
 - b. Low voltage transformer to be Square D or equivalent.
 - c. NEMA 3R enclosure rating.
 - d. Stepdown shall be one of the following:
 - 1) 240/480 volt primary to 120/240 volt secondary 60 Hz
 - 2) 600 volt primary to 120/240 volt secondary 60 Hz
 - 3) 190/200/208/220 or 380/400/416/440 volt primary to 110/220 volt secondary 50/60 Hz.
3. Wiring and Harnesses:
 - a. Wiring harnesses shall be specifically designed for the unit configuration. Generic wiring harnesses are not acceptable.
 - b. Wire assemblies shall be thermoplastic heat resistant nylon coated (THHN) stranded copper (90°C) or AWM wire. All wires used shall be moisture resistant. Conductors shall be bundled and sleeved with heat-shrink material over connector end and sleeve. All colored electrical tape for wire marking shall be “3M Super 35 electrical tape”. For readability, laser print to be black on white background, smudge and wear resistant for life of wire assembly. The crimping of connectors to wires and the assembly of connectors to contactors shall follow manufacturer’s instructions.
 - c. Wiring harnesses shall have polarized plugs that can only be assembled one way. Plugs shall have the ground lug identified by a green connector, while all of the powered lugs shall be black.
 - d. If a shipping split is inserted in the unit configuration, a label shall instruct the assembler to connect the single point wiring harness before the two unit sections are mated. Each wiring harness shall extend at least 12 in. from each shipping split to allow the harnesses to be mated.
- C. Marine Lights and Convenience Outlets:
 1. Cast, non-ferrous metal, weatherproof, fixture.
 2. Cast, non-ferrous metal, weatherproof, electrical junction box.
 3. Gasketed, heat and shock resistant glass globe protects against moisture and debris.
 4. Cast, non-ferrous metal lamp guard to protect glass globe.
 5. UL and CSA listed.
 6. 100 watt type ‘A’ lamp maximum capacity.
 7. Each fixture is equipped with a 9.5 watt, 120 volt 800 lumen LED lamp with an average rated life of 25,000 hours, factory installed.
 8. Metallic, single gang, electrical junction box, UL listed.
 9. With convenience outlet: Factory supplied and wired, SPST, toggle switch and 15 amp, 120 vac/60 Hz, NEMA 5-15 type, ground fault circuit interrupt (GFCI) receptacle, UL listed.
 10. Without convenience outlet: Factory supplied and wired, SPST, UL listed toggle switch.
 11. Each fixture is factory wired to an externally mounted switch box. (Field power connections are made to the switch box mounted externally on the unit.)
 12. All factory wiring penetrating through the panel is protected in ‘RIGID’ type metal conduit.
- D. Disconnects:

Factory-supplied disconnects shall be covered under a 1 year limited warranty from the manufacturer from the date of shipment.

1. 115-230 volt/single-phase non-fused disconnects shall have the following characteristics:
 - a. Plated current carrying components for superior corrosion protection.
 - b. Factory-installed equipment grounding terminals with slot/square drive screws.
 - c. Rated for motor disconnect applications (10 Hp maximum).
 - d. NEMA type 3R non-metallic enclosure.
 - e. Up to 10,000 rms symmetrical amperes SCCR, when protected by a fuse or circuit breaker rated 60 amperes or less.
 - f. Cover padlock hasp.
 - g. Pull-out cartridge type.
 - h. UL listed.
 2. 115-230 volt/single-phase fused disconnects shall have the following characteristics:
 - a. Visible blades.
 - b. Quick-make, quick-break operating mechanism.
 - c. Cover padlock hasp and handle lock “OFF.”
 - d. 240 vac maximum.
 - e. Factory supplied and installed class ‘T Series’ fuses (fused disconnects only).
 - f. Up to 10,000 rms symmetrical amperes SCCR, utilizing appropriately rated factory-supplied fuses.
 - g. Horsepower rated for motor applications.
 - h. Tangential combination knockouts for field wiring.
 - i. Spring reinforced plated copper fuse clips.
 - j. NEMA type 1 enclosures.
 - k. Insulated, bondable solid neutral assemblies.
 - l. UL listed, File E2875.
 - m. Meet or exceed NEMA KS1-1990.
 3. 200-230 volt/3-phase fused and non-fused disconnects shall have the following characteristics:
 - a. Visible blades.
 - b. Quick-make, quick-break operating mechanism.
 - c. Cover padlock hasp and handle lock “OFF.”
 - d. 240 vac maximum.
 - e. Factory supplied and installed class RK5 fuses (fused disconnects only).
 - f. Up to 100,000 rms symmetrical amperes SCCR, utilizing appropriately rated, factory-supplied Class R fuses.
 - g. Horsepower rated for motor applications.
 - h. Tangential combination knockouts for field wiring.
 - i. Spring reinforced plated copper fuse clips.
 - j. NEMA type 1 enclosures.
 - k. Insulated, bondable solid neutral assemblies.
 - l. UL listed, File E2875.
 - m. Meet or exceed NEMA KS1-1990.
 4. 380-575 volt/3-phase fused and non-fused disconnects shall have the following characteristics:
 - a. Visible switch blades with for positive “OFF” indication.
 - b. Quick-make, quick-break operating mechanism.
 - c. Dual cover interlock.
 - d. Color coded “ON” — “OFF” indicator handle.
 - e. Cover padlock hasp and handle lock “OFF” provision for multiple padlocks.
 - f. 600 vac maximum.
 - g. Factory supplied and installed class RK5 fuses (fused disconnects only).
 - h. Up to 200,000 rms symmetrical amperes SCCR, utilizing appropriately rated, factory-supplied Class R fuses.
 - i. Horsepower rated for motor applications.
 - j. Spring reinforced plated copper fuse clips.
 - k. Tangential combination knockouts.
 - l. NEMA type 1 enclosures.
 - m. Insulated, bondable solid neutral assemblies.
 - n. Wire terminations suitable for aluminum or copper conductors.
 - o. UL listed.
 - p. Meet or exceed NEMA KS1-1999.
- E. Starters:
- Factory-supplied disconnects shall be covered under a 1 year limited warranty from the manufacturer from the date of shipment.
1. Starter without disconnect:
 - a. Adjustable motor overload with trip indication.
 - b. Manual overload reset button (accessible without opening enclosure).
 - c. 115-v fused secondary control transformer (fuse included — fused primary and secondary over 50 amps).
 - d. Hand/Off/Auto selector switch (accessible without opening enclosure).
 - e. Separate 4-position terminal strip for remote H-O-A wiring.
 - f. C series contactors.
 - g. Horsepower rated for motor applications.
 - h. NEMA 4 or higher enclosures.
 - i. Lug connections for field wiring.
 - j. Factory mounted, wired, and run tested with factory-supplied motor.
 - k. UL listed.

2. Combination Starter/Disconnect:
 - a. Non-fused UL 508 disconnect switch with lockable handle (locks not provided).
 - b. Cover interlock.
 - c. Adjustable motor overload with trip indication.
 - d. Manual overload reset button (accessible without opening enclosure).
 - e. 115-v fused secondary control transformer (fuse included — fused primary and secondary over 50 amps).
 - f. Hand/Off/Auto selector switch (accessible without opening enclosure).
 - g. Separate 4-position terminal strip for remote H-O-A wiring.
 - h. C series contactors.
 - i. Horsepower rated for motor applications.
 - j. NEMA 4 or higher enclosures.
 - k. Lug connections for field power wiring.
 - l. Factory mounted, wired, and run tested with factory-supplied motor.
 - m. UL listed.
- F. External Bypass for Variable Frequency Drives:
 Factory-supplied bypasses shall be covered under a 1 year limited warranty from the manufacturer from the date of shipment.
1. 200-230 v/3 Ph/60 Hz (1 to 7.5 Hp), 460-575 v/3 Ph/60 Hz (1 to 20 Hp), 380 v/3 Ph/50 Hz (1 to 15 Hp):
 - a. 4-position panel-mounted disconnect style switch with lockable handle (locks not provided), meets OSHA 1910.
 - b. Switch position indication (LINE/OFF/DRIVE/TEST).
 - c. Adjustable motor overload with trip indication (LINE position).
 - d. Manual overload reset button.
 - e. Horsepower rated for motor applications.
 - f. Direct control (no contactors, relays, or holding coils).
 - g. Complete isolation of inverter in LINE position.
 - h. NEMA 12 type metal enclosures.
 - i. Terminal strip provided for field power supply wiring.
 - j. Lug connection for field ground wire.
 - k. Gold flashed, auxiliary switch contact set (for switch position monitoring).
 - l. Factory mounted, wired to VFD and motor, and run tested (motor and VFD must be factory supplied and installed).
 - m. UL; UL, Canada; CE listed.
2. 200-230 v/3 Ph/60 Hz (10 to 75 Hp), 460-575 v/3 Ph/60 Hz (25 to 150 Hp), 380 v/3 Ph/50 Hz (20 to 75 Hp):
 - a. 4-position panel-mounted disconnect style switch with lockable handle (locks not provided), meets OSHA 1910.
 - b. Switch position indication (LINE/OFF/DRIVE/TEST).
 - c. Adjustable motor overload with trip indication (in LINE position).
 - d. Manual overload reset button.
 - e. Horsepower rated for motor applications.
 - f. 115-v control transformer with fused secondary (fused primary on units over 50 amps).
 - g. Contactor for Line Start/Stop.
 - h. Door-mounted Line Start and Line Stop pushbuttons.
 - i. Complete isolation of inverter in LINE position.
 - j. NEMA 12 type metal enclosures.
 - k. Terminal strip provided for field power supply wiring.
 - l. Lug connection for field ground wire.
 - m. Gold flashed, auxiliary switch contact set (for switch position monitoring).
 - n. Factory mounted, wired to VFD and motor, and run tested (motor and VFD must be factory supplied and installed).
 - o. UL; UL, Canada; CE listed.
- G. Variable Frequency Drives:
1. Referenced Standards and Guidelines:
 - a. Institute of Electrical and Electronic Engineers (IEEE)
 - 1) IEEE 519-2014, IEEE Recommended Practice and Requirements for Harmonic Control in Electric Power Systems.
 - b. Underwriters Laboratories (as appropriate)
 - 1) UL508A
 - 2) UL 61800-5-1
 - c. National Electric Code (NEC)
 - 1) NEC 430.120, Adjustable-Speed Drive Systems
 - d. CSA Group
 - 1) CSA C22.2 No. 274
 - e. International Building Code (IBC)
 - 1) IBC 2018 Seismic - referencing ASCE 7-16 and ICC AC-156
 2. Qualifications:
 - a. Drives shall be UL labeled as a complete assembly. The base VFD shall be UL listed for 100 kA SCCR when installed in accordance with the manufacturer's guidelines.

- b. CE Mark - The base drive shall conform to the European Union Electromagnetic Compatibility directive, a requirement for CE marking. The base drive shall meet product standard EN 61800-3 for the First Environment restricted distribution (Category C2).
 - c. The base drive shall be seismically certified and labeled as such in accordance with the 2018 International Building Code (IBC):
 - 1) Seismic importance factor of 1.5, and minimum 2.5 SDS rating is required.
 - 2) Ratings shall be based upon actual shake test data as defined by ICC AC-156, via all three axis of motion.
 - 3) Seismic certification of equipment and components shall be provided by HCAI (formerly OSHPD) preapproval.
 - d. The base drive shall be SEMI-F47 certified. The drive must tolerate voltage sags to 50% for up to 0.2 seconds, sags to 70% for up to 0.5 seconds, and sags to 80% for up to one second.
 - e. Factory-mounted variable frequency drives (VFDs) shall be wired to factory-supplied motors.
 - f. Factory-supplied VFDs are programmed and started up from the factory and qualify the VFD, through ABB, for a 36-month warranty from date of commissioning or 40 months from date of sale, whichever occurs first.
 - g. The VFD parameters are programmed into the controller and removable keypad. In the event that the VFD fails and needs replacement, the program can then be uploaded to the replacement VFD via the original keypad.
- 3. The drive package as specified herein and defined on the drive schedule shall be enclosed in a UL Type enclosure (enclosures with only NEMA ratings are not acceptable), completely assembled and tested by the manufacturer to ISO9001 standards.
 - 4. The drive shall provide full rated output from a line of +10% to -15% of nominal voltage. The drive shall continue to operate without faulting from a line of +25% to -35% of nominal voltage.
 - a. Drives shall be capable of continuous full load operation under the following environmental operating conditions:
 - 1) Ambient temperature -15 to 40°C (5 to 104°F).
 - 2) Altitude 0 to 1000 m (0 to 3,300 ft) above sea level.
 - 3) Humidity 5 to 95%, non-condensing.
 - 5. All drives shall utilize the same Advanced Control Panel (keypad) user interface.
 - a. Plain English text
 - 1) The display shall be in complete English words for programming and fault diagnostics (alpha-numeric codes are not acceptable).
 - 2) Safety interlock and run permissive status shall be displayed using predetermined application specific nomenclature, such as: Damper end switch, smoke alarm, vibration trip, and overpressure.
 - 3) Safety interlock, run permissive, Supervisory, external fault status, drive name, drive fault contact info and override shall have the option of additional customized project specific terms, such as: AHU-1 End Switch, Office Smoke Alarm, CT-2 Vibration.
 - b. The control panel shall include at minimum the followings controls:
 - 1) Four navigation keys (Up, Down, Left, Right) and two soft keys to simplify operation and programming.
 - 2) Hand-Off-Auto selections and manual speed control without having to navigate to a parameter.
 - 3) Fault Reset and Help keys. The Help key shall include assistance for programming and troubleshooting.
 - c. Multiple Home View screens shall be capable of displaying up to 21 points of information. Customizable modules shall include bar charts, graphs, meters, and data lists. Displays shall provide real time graphical trending of output power, frequency, and current within selectable intervals of 15/30/60 minutes and 24 hours.
 - d. The control panel shall display the following items on a single screen; output frequency, output current, reference signal, drive name, time, and operating mode (Hand vs Auto, Run vs Stop). Bi-color (red/green) status LED shall be included. Drive (equipment) name shall be customizable.
 - e. There shall be a built-in time clock in the control panel. The clock shall have a battery backup with 10 years minimum life span. Daylight savings time shall be selectable.
 - f. I/O Summary display with a single screen shall indicate and provide:
 - 1) The status/values of all analog inputs, analog outputs, digital inputs, and relay outputs. Drives that require access to internal or live components to measure these values, are not acceptable.
 - 2) The programmed function of all analog inputs, analog outputs, digital inputs, and relay outputs.

- 3) The ability to force individual digital I/O high or low and individual analog I/O to desired value, for increased personal protection during drive commissioning and troubleshooting. Drives that require access to internal or live components to perform these functions, are not acceptable.
 - g. The drive shall automatically backup parameters to the control panel. In addition to the automatic backup, the drive shall allow two additional unique backup parameter sets to be stored. Backup files shall include a time and date stamp. In the event of a drive failure, the control panel of the original drive can be installed on the replacement drive, and parameters from that control panel can be downloaded into the replacement drive.
 - h. The control panel shall display local technical support contact information as part of drive fault status.
 - i. The control panel shall be removable, capable of remote mounting.
 - j. The control panel shall have the ability to store screen shots, which are downloadable via USB.
 - k. The drive shall generate a QR code, which contains drive identification data, information on the latest events, and values of status and counter parameters.
 - l. The LCD screen shall be backlit with the ability to adjust the screen brightness and contrast, with inverted contrast mode. A user-selectable timer shall dim the display and save power when not in use. The control panel shall include assistants specifically designed to facilitate start-up. Assistants shall include: First Start Assistant, Basic Operation, Basic Control, and PID Assistant.
 - m. Primary settings for HVAC shall provide quick set-up without the use of alpha-numerical parameters, for commissioning the drive and customer interfaces to reduce programming time.
 - n. The drive shall be able to operate with the control panel removed.
 - o. The drive shall be able to support a Bluetooth Advanced Control Panel. The Bluetooth control panel shall be FCC and QDL (Qualified Design Listing) certified.
 - 1) A free app (iOS and Android) shall replicate the control panel on a mobile device or tablet. The control panel's programming and control functionality shall function on the device. Customizing text, such as AHU-1 End Switch, shall be supported by the device's keyboard.
 - 2) Bluetooth connectivity shall allow uploading, downloading, and emailing of parameter sets.
 - 3) Bluetooth connectivity shall include two pairing modes: Always discoverable with a fixed passcode, and manual discovery with a unique generated passcode every pairing.
 - 4) Bluetooth connectivity shall be capable of being switched.
6. All drives shall have the following hardware features/characteristics as standard:
 - a. Two (2) programmable analog inputs shall accept current or voltage signals. Current or Voltage selection configured via control panel. Drives that require access to internal components to perform these functions, are not acceptable.
 - b. Two (2) programmable analog outputs. At least one of the analog outputs shall be adjustable for current or voltage signal, configured via control panel. Drives that require access to internal components to perform these functions, are not acceptable.
 - c. Six (6) programmable digital inputs. All digital inputs shall be programmable to support both active high and active low logic, and shall include adjustable on/off time delays. The digital input shall be capable of accepting both 24 VDC and 24 VAC.
 - d. Three (3) programmable Form-C relay outputs. The relay outputs shall include programmable on/off time delays. The relays shall be rated for a continuous current rating of 2 Amps. Maximum switching voltage of 250 VAC / 30 VDC. Open collector and Form-A relays are not acceptable. Drives that have less than (3) Form-C relay outputs shall provide an option card to provide additional relay outputs.
 - e. Drive terminal blocks shall be color coded for easy identification of function.
 - f. The drive shall include an isolated USB port for interface between the drive and a laptop. A non-isolated USB port is not acceptable.
 - g. An auxiliary power supply rated at 24 VDC, 250 mA shall be included.
 - h. At a minimum, the drives shall have internal impedance equivalent to 5% to reduce the harmonics to the power line. 5% impedance may be from dual (positive and negative DC link) chokes, or AC line reactor. Drives with only one DC link choke shall add an AC line choke integral to the drive enclosure. Reference the drive schedule to determine if additional harmonic mitigation is required for the system to comply with IEEE 519-2014.

- i. The drive shall have cooling fans that are designed for field replacement. The primary cooling fan shall operate only when required and be variable speed for increased longevity and lower noise levels. Drives whose primary cooling fans are not variable speed, shall include a spare cooling fan.
 - j. The overload rating of the drive shall be 110% of its normal duty current rating for 1 minute every 10 minutes, 135% overload for 2 seconds every minute. The minimum current rating shall meet or exceed the values in the NEC/UL table 430.250 for 4-pole motors.
 - k. The input current rating of the drive shall not be greater than the output current rating. Per NFPA 70 430.122, drives with higher input current ratings may require the upstream wiring, protection devices, and source transformers to be upsized.
 - l. Circuit boards shall be coated per IEC 60721-3-3; Chemical gases Class 3C2 and Solid particles Class 3S2.
 - m. Earth (ground) fault detection shall function in both modulating (running) and non-modulating modes.
 - n. Coordinated AC transient surge protection system consisting of 4 MOVs (phase-to-phase and phase-to-ground), a capacitor clamp, and internal chokes. The MOVs shall comply with UL 1449 4th Edition. Drives that do not include coordinated AC transient surge protection shall include an external TVSS/SPD (Transient Voltage Surge Suppressor/Surge Protection Device).
 - o. The drive shall include a robust DC bus to provide short term power-loss ride through. The DC bus Joule to drive kVA ratio shall be 4.5 J/kVA or higher. An inertia-based ride through function should help maintain the DC bus voltage during power loss events. Drives with control power ride through only, are not acceptable.
7. All drives shall have the following software features as standard:
- a. A Fault Logger that stores the last 16 faults in non-volatile memory.
 - 1) The most recent 5 faults save at least 9 data points, including but not limited to: Time/date, frequency, DC bus voltage, motor current, DI status, temperature, and status words.
 - 2) The date and time of each fault and fault reset attempt shall be stored in the Fault Logger.
 - b. An Event Logger that stores the last 16 warnings or events that occurred, in non-volatile memory.
 - 1) Events shall include, but not limited to: Warning messages, checksum mismatch, run permissive open, start interlock open, automatic reset of a fault, power applied, auto start command, auto stop command, modulating started, and modulating stopped.
 - 2) The date and time of each event's start and completion points shall be stored in the Event Logger.
 - 3) The drive shall also provide the user the ability to configure what events to log for application specific requirements.
 - c. Programmable start method. Start method shall be selectable based on the application and function even if the motor was free-wheeling in the reverse direction: Flying-start, Normal-start, and Brake-on-start.
 - d. Programmable loss-of-load (broken belt/ coupling) indication. Indication shall be selectable as a control panel warning, relay output, or over network communications. This function to include a programmable time delay to eliminate false loss-of-load indications.
 - e. The following three-phase AC motor technologies shall be compatible:
 - 1) Asynchronous induction motors
 - 2) Permanent magnet synchronous (non-salient pole) motor
 - 3) Synchronous reluctance motor (SynRM)
 - 4) Permanent magnet assisted synchronous reluctance motor (PMA SynRM)
 - f. Motor heating function to prevent condensation build up in the motor. Motor heating adjustment, via parameter, shall be in "Watts." Heating functions based only on "percent current" are not acceptable.
 - g. Motor disconnect detection function enables the drive to detect when an output disconnect is opened, disable the drive output, and provide an indication message. Drives without this functionality shall have a disconnect switch auxiliary contact wired through dedicated conduit back to the drive enable control circuit.
 - h. Motor phase order shall be changeable through software interface.
 - i. Advanced power metering abilities shall be included in the drive and must be available over network communications. Drives without these data points, must include a separate power meter with each drive.
 - 1) Instantaneous output power (kW).

- 2) Total power, broken down by kWh, MWh, and GWh units of measurement. Power meters that only display kWh and roll over or “max out” once the maximum kWh value is reached, are not acceptable. There shall be resettable and non-resettable total power meters within the drive.
- 3) Time based kWh metering for: current hour, previous hour, current day, and previous day.
- 4) Energy saving calculation shall be included that shows the energy and dollars saved by the drive.
- j. The drive shall include a motor flux optimization circuit that will automatically reduce applied motor voltage to the motor to optimize energy consumption and reduce audible motor noise.
- k. DC bus voltage ripple function shall provide a DC voltage reference for troubleshooting AC line issues or bus capacitor health.
- l. Run permissive circuit - There shall be a run permissive circuit for damper or valve control. The drive shall provide a relay output to the damper actuator, monitor end-switch status, and start running the motor based on application requirements. Damper control shall include the following configurable features fully functional in both Hand and Auto modes:
 - 1) A timeout function that identifies and annunciates a specific warning message when a damper has not opened or closed within the allotted time.
 - 2) Ability to interface with both damper open and damper closed end-switches on a single damper actuator.
 - 3) Sequence control that runs the fan initially at a fixed speed before commanding a discharge air damper to open. Required for all applications feeding a common plenum/space to prevent the fan from freewheeling backwards while damper strokes open.
 - 4) Multiple damper sequence control to support units with discharge air and outside air dampers. The drive shall command and verify the outside air damper is open before ramping the fan to a fixed speed, and then commanding the outside air damper open.
 - 5) Time based damper control for when an end-switch is not provided. For units with outside air and discharge air dampers, both dampers should have independent time based control capability.
- m. Start interlock circuit - Four separate start interlock (safety) inputs shall be provided. When any safety is opened, the motor shall be commanded to stop. The control panel will display the specific safety(s) that are open. The status of each safety shall be transmitted over the network communications. Wiring multiple safeties in series is not acceptable.
- n. External fault circuit - Three separate external fault inputs shall be provided. This circuit shall have the same features and functionality as the start interlock circuit, except it shall require a manual reset before the drive is allowed to operate the motor.
- o. The drive shall provide automatic protections to allow uninterrupted operations at a reduced speed or switching frequency.
 - 1) Switching frequency control circuit, that reduces the switching frequency based on actual drive temperature and allows higher switching frequency settings without derating the drive. It shall be possible to set a minimum and a target switching frequency.
 - 2) The drive shall include a temperature limit that when exceeded will reduce the drive output current.
 - 3) Input phase loss protection shall be provided, whereas the output current is automatically derated by 50% if an input phase loss is detected by the drive.
- p. Visual function block adaptive programming allowing custom control schemes, minimizing the need for external controllers (i.e., cooling tower staging logic). A free software tool shall be used to configure adaptive programming.
- q. The ability to automatically restart after an over-current, over-voltage, under-voltage, external fault, or loss of input signal protective trip. The number of restart attempts, trial time, and time between attempts shall be programmable. Each of these faults may have automatic restart individually disabled via a parameter selection.
- r. Three (3) programmable critical frequency lockout ranges to prevent the drive from operating the load continuously at an unstable speed/load.
- s. The drive shall have three methods to control constant frequency/speed references:
 - 1) Seven (7) programmable preset frequencies/speeds using (3) inputs.
 - 2) Six (6) different programmable preset frequencies/speed tied to 6 independent control inputs and requires an additional start command.

- 3) Six (6) different programmable preset frequencies/speed tied to 6 independent control inputs and does not require any additional start command input.
 - t. Two independently adjustable accel and decel ramps sets with 1 - 1800 seconds adjustable time ramps.
 - u. PID functionality shall be included in the drive.
 - 1) Programmable “Sleep” and “Wake up” functions to allow the drive to be started and stopped based on the level of a process feedback signal.
 - 2) The drive shall include an independent PID loop for customer use, assigned to an Analog Output. This PID loop may be used for cooling tower bypass valve control, chilled water valve, etc.
 - v. At least 4 parameter user sets that can be saved to the permanent memory and recalled using a digital input, timed function, or supervision function.
 - w. Drive shall be compatible with an accessory that allows the control board to be powered from an external 24 VDC/VAC source, allowing the drive control to remain powered by a UPS during an extended power outage.
 - x. A computer-based software tool shall be available to allow a laptop to program the drive. The drive shall be able to support programming without the need for line voltage. All necessary power shall be sourced via the laptop USB port.
 - y. The drive shall include a fireman’s override mode. Upon receipt of a contact closure from the Fire Alarm Life Safety system, the drive shall operate in a dedicated Override mode distinct and separate from the drive’s Normal operation mode. The following features will be available in the drive override function:
 - 1) The Override mode shall be secured by passcode to prevent changes once programmed.
 - 2) The drive shall ignore external inputs and commands not defined as part of the override function.
 - 3) Override operation mode shall be selectable between: single frequency, multiple fixed frequencies, follow an analog input signal, PID control, or come to a forced stop.
 - 4) High priority safeties shall stop the drive and lower priority safeties shall be ignored in Override mode.
 - 5) Drive faults shall be defined in Critical and Low priority groups. Critical faults shall stop the drive. Low priority faults shall be reset. Reset trials and timing shall be programmable.
 - 6) The drive shall be configurable to receive from 1 to 3 discrete digital input signals and operate at up to three discrete speeds.
- ## 8. Security Features
- a. The drive manufacturer shall clearly define cybersecurity capabilities for their products.
 - b. The drive shall include passcode protection against parameter changes.
 - 1) There shall be multiple levels of passcode protection including: End User, Service, Advanced, and Override.
 - 2) The drive shall support a customer generated unique passcode between 0 and 99,999,999.
 - 3) The drive shall log an event whenever the drive passcode has been entered.
 - 4) The drive shall provide a security selection that prevents any “back door” entry. This selection even prevents the drive manufacturer from being able to bypass the security of that drive.
 - 5) A security level shall be available that prevents the drive from being flashed with new firmware.
 - c. A checksum feature shall be used to notify the owner of unauthorized parameter changes made to the drive. The checksum feature includes two unique values assigned to a specific programming configuration.
 - 1) One checksum value shall represent all user editable parameters in the drive except communication setup parameters. A second checksum value shall represent all user editable parameters except communication setup, energy, and motor data parameters.
 - 2) Once the drive has been commissioned the two values can be independently saved in the drive.
 - 3) The drive shall be configurable to either: Log an Event, provide a Warning, or Fault upon a parameter change when the current checksum value does not equal the saved checksum value.
 - d. The “Hand” and “Off” control panel buttons shall have the option to do the following:
 - 1) Be individually disabled (via parameter) for drives mounted in public areas to prevent unauthorized changes.

- 2) Require a second button press of “Hand” or “Off” within 5 seconds of the original selection to confirm the change and prevent accidental transition out of “Auto” mode.
9. Network Communications
 - a. The drive shall have an EIA-485 port with removable terminal blocks. The onboard protocols shall be BACnet MS/TP, Modbus, and Johnson Controls N2. Optional communication cards for BACnet/IP, LonWorks, Profibus, Profinet, EtherNet/IP, Modbus TCP, and DeviceNet shall be available. The use of third party gateways are not acceptable.
 - b. The drive shall have independent end of line (EOL) termination and biasing switches for EIA-485 networks.
 - c. The drive shall contain EIA-485 network self-diagnostics to assist in troubleshooting issues such as incorrect polarity, incorrect baud rate, noise on the wire or addressing errors.
 - d. The drive shall have the ability to communicate via two protocols at the same time, one onboard protocol and one option card based protocol. Once installed, the drive shall automatically recognize any optional communication cards without the need for additional programming.
 - e. The drive shall not require a power cycle after communication parameters have been updated.
 - f. The embedded BACnet connection shall be a MS/TP interface. The drive shall be BTL Listed to Revision 14 or later. Use of non-BTL Listed drives are not acceptable.
 - g. The drive shall be classified as an Applications Specific Controller (B-ASC). The interface shall support all BIBBs defined by the BACnet standard profile for a B-ASC including, but not limited to:
 - 1) Data Sharing: Read Property Multiple-B, Write Property Multiple-B, COV-B
 - 2) Device Management: Time Synchronization-B
 - 3) Object Type Support: MSV, Loop
 - h. The drive’s relay output status, digital input status, analog input/output values, Hand-Auto status, warning and fault information shall be capable of being monitored over the network. The drive’s start/stop command, speed reference command, relay outputs and analog outputs shall be capable of being controlled over the network. Remote drive fault reset shall be possible.
 10. Disconnect (optional) - A circuit breaker or disconnect switch shall be provided when indicated on the drive schedule. The disconnect shall be door interlocked and padlockable. Drive input fusing shall be included on all packaged units that include a disconnecting means. All disconnect configurations shall be UL Listed by the drive manufacturer as a complete assembly and carry a UL508A label. Disconnect packages manufactured by anyone other than the drive manufacturer, are not acceptable.
 11. Eclipse Bypass (optional) - Bypass drive packages shall be provided when indicated on the drive schedule. All drive/bypass configurations shall be UL Listed by the drive manufacturer as a complete assembly and carry a UL508A label. Bypasses manufactured by anyone other than the drive manufacturer, are not acceptable.
 - a. The drive and bypass package shall be a complete factory wired and tested bypass system consisting of a padlockable disconnect device, drive output contactor, bypass contactor, and drive input fuses.
 - b. The drive and bypass package shall have a UL listed short circuit current rating of 100 kA, for 240 VAC and 480 VAC systems, and this rating shall be indicated on the rating label.
 - c. The bypass control shall be powered by a three-phase switch mode power supply with a voltage tolerance of +30%, -35%. Single-phase power supplies and control power transformers (CPT) are not acceptable.
 - d. The drive and bypass package shall be seismic certified and labeled to the IBC. Seismic importance factor of 1.5 rating is required and shall be based upon actual shake table test data as defined by ICC AC-156. Seismic certification of equipment and components shall be provided by HCAI (formerly OSHPD) preapproval.
 - e. All bypass packages shall utilize a dedicated LCD bypass control panel (keypad) user interface. The bypass control panel must be a separate display from the drive control panel. Bypass packages that use a single shared drive/bypass control panel are not acceptable, due to that control panel acting as a single point of failure.
 - 1) The bypass shall include a two-line, 20-character LCD display. The display shall allow the user to access parameters and view:
 - a) All three phases of the bypass input voltage, current (Amps) and power (kW)
 - b) Bypass faults, warnings, and fault logs

- c) Bypass operating time and energy consumption (resettable)
- 2) The bypass control panel shall include the following controls:
 - a) Four navigation keys (Up, Down, Enter, Escape)
 - b) Bypass Hand-Off-Auto, Drive mode / Bypass mode selectors, Bypass fault reset
- 3) The following indicating lights (LED PTT type) or control panel display indications shall be provided.
 - a) Drive mode selected, Bypass mode selected
 - b) Drive running, Bypass running
 - c) Drive fault, Bypass fault
- 4) Safety interlock and run permissive status shall be displayed using predetermined application specific nomenclature, such as: Damper end switch, smoke alarm, vibration trip, and overpressure.
- f. All bypasses shall have the following hardware features/characteristics as standard:
 - 1) Six (6) digital inputs and five (5) Form-C relay outputs. The digital inputs shall be capable of accepting both 24 VDC and 24 VAC. The bypass control board shall include an auxiliary power supply rated 24 VDC, 250 mA.
 - 2) Drive isolation fuses shall be provided. Bypass designs which have no such fuses, or that only incorporate fuses common to both the drive and the bypass are not acceptable. Third contactor “isolation contactors” and service switches are not an acceptable alternative to drive isolation fuses.
 - 3) The bypass shall be able to detect a single-phase input power condition before the bypass contactor closes or while running the motor in bypass, by monitoring all three phases of input voltage. Relying on a high current trip if the motor is single-phased is not acceptable.
 - 4) The bypass shall be designed for stand-alone operation and be completely functional in both Hand and Automatic modes, even if the drive and/or drive’s control board has failed. Network communications shall remain functional. Bypass systems that do not maintain full functionality in the event of a drive failure, are not acceptable.
- g. All bypasses shall have the following software features as standard:
 - 1) Programmable loss-of-load (broken belt / coupling) indication shall be functional in drive and bypass mode.
 - 2) The bypass shall also support run permissive and start interlock control functionality, including start delay, as previously specified in the drive section.
 - 3) The bypass control shall monitor the status of the drive and bypass contactors and indicate when there is a welded contactor contact or open contactor coil.
 - 4) The bypass shall include a selection for either manual or automatic transfer to bypass. The automatic transfer mode shall allow the user to select the specific drive fault types that result in an automatic transfer to bypass. The automatic transfer mode shall not allow a transfer to bypass on motor related faults. Automatic transfer schemes that do not differentiate between fault types, are not acceptable.
 - 5) The bypass shall include the ability to select the operating mode of the system (Drive/Bypass) from either the bypass control panel or digital input.
 - 6) The bypass shall include the ability to know the phase sequence and provide a phase sequence fault to indicate if the bypass and drive would run the motor in the opposite direction, this feature shall be enabled by default
 - 7) The bypass shall include a supervisory control mode that monitors the value of the drive’s analog input (feedback). This feedback value is used to control the bypass contactor on/off state. The supervisory mode shall allow the user to maintain hysteresis control over applications such as cooling towers and booster pumps.
 - 8) Selectable Class 10, 20, or 30 electronic motor overload protection shall be included in both drive and bypass

- 9) The drive and bypass shall be designed to operate as an integrated system when in Override mode. Whether operating in drive or bypass mode, the low priority safeties will be ignored, and high priority safeties will be followed. External start/stop commands will be ignored. There shall be four selectable Override modes:
 - a) Bypass only, with two smoke control modes:
 - i) Fixed pre-configuration of digital inputs
 - ii) Configurable high/low priority safeties and faults, to allow configuration to meet needs of local authority having jurisdiction.
 - b) Drive only
 - c) Drive then transfer to bypass, in the event of a drive fault
 - d) Force to stop
- 10) Before the bypass circuit can be tested in commissioning, the drive must start the motor to check for shorts and ground faults.
 - h. Network communications - the bypass shall include BACnet MS/TP, Modbus, and Johnson Controls N2 as standard. The bypass BACnet implementation shall be BTL Listed to Revision 14 or later. Optional communication cards for BACnet/IP, LonWorks, Profibus, Profinet, Ethernet/IP, Modbus TCP, and DeviceNet shall be available.
 - 1) The bypass relay output status, digital input status, warning and fault information can be monitored over the network. Status information shall be monitored, including; operating mode (drive vs bypass), current drawn in bypass mode, broken belt, and phase-to-phase voltage. The bypass start/stop command, force to bypass command, and relay outputs shall be capable of being controlled over the network.

39MW Weathertight Outdoor Air Handlers

HVAC Guide Specifications

Size Range: **1,500 to 60,500 Nominal Cfm**

Carrier Model Number: **39MW — Outdoor Unit**

Part 1 — General

1.01 QUALITY ASSURANCE

- A. Manufacturer Qualifications:
Company specializing in manufacturing the products specified in this section with minimum of 5 years documented experience.
- B. The management system governing the manufacture of this product is ISO (International Organization for Standardization) 9001:2015 certified.
- C. Air-handling unit assembly shall have UL (Underwriters Laboratories) 60335-2-40 certification for safety, including use with electric heat.
- D. Products requiring electric connection shall be listed and classified by cULus as suitable for the purpose specified and indicated.
- E. All coils shall be rated in accordance with AHRI Standard 410, latest edition. Chilled water, hot water, and steam coils shall be certified, in accordance with AHRI Standard 410.
- F. Direct expansion coils shall be designed and tested in accordance with ANSI/ASHRAE (American National Standard Institute/American Society of Heating, Refrigerating and Air-Conditioning Engineers) 15 Safety Code for Mechanical Refrigeration.
- G. Unit performance shall be rated in accordance with AHRI Standard 430 for Central Station Air Handling Unit Supply Fans and subject to verification of rating accuracy by AHRI-sponsored, third party testing.
- H. Units shall meet NFPA (National Fire Protection Association) 90A requirements.

1.02 DELIVERY, STORAGE AND PROTECTION

- A. All outdoor units shall be completely shrink-wrapped from the factory for protection during shipment. Tarping of bare units is unacceptable.
- B. Inspect for transportation damage and store in clean dry place and protect from weather and construction traffic. Handle carefully to avoid damage to components, enclosures, and finish.

1.03 START-UP REQUIREMENTS

Do not operate units until ductwork is clean, filters are in place, bearings lubricated, condensate properly trapped, piping connections verified and leak tested, belts aligned and tensioned, all shipping braces have been removed, and fan has been test run under observation.

Part 2 — Products

2.01 GENERAL DESCRIPTION

- A. Units shall ship in the number of sections necessary to meet project requirements and shall ship in as many splits as specified in selection software. Split options as follows:
 1. Shipped in sections — shipping split.
 2. Shipped assembled — base rail break (shipped attached).
 3. Shipped assembled — solid base rail.
- B. Unit shall be factory-supplied, factory-assembled, outdoor, curb-mounted central station air handler. The air-handling unit may consist of a fan with the following factory-installed components as indicated on the equipment schedule.
 1. Mixing Box Section:
 - a. No filter tracks.
 - b. With filter tracks.
 - c. With angle filter tracks
 - d. With bag cartridge filter tracks.
 - e. With exhaust air dampers.
 2. Air Mixing Section.
 3. Exhaust Box Section.
 4. Integral Face and Bypass Section:
 - a. With hot water coil.
 - b. With steam coil.
 5. Internal Face and Bypass Damper Section.
 6. Plenum Section:
 - a. With drain pan.
 - b. No drain pan.
 7. Humidifier Section.
 8. Blow-Thru Discharge Plenum.
 - a. With no openings
 - b. With custom discharge openings
 9. Filter Section:
 - a. 2-in. flat filters.
 - b. 4-in. flat filters.
 - c. 4-in. flat filters with 2-in. pre-filters.
 - d. 2-in. angle filters.
 - e. 4-in. angle filters.
 - f. Side loading 12-in. bag/cartridge filters with 2-in. pre-filters.
 - g. Side loading 30-in. bag/cartridge filters with 2-in. pre-filters.
 - h. Face loading bag/cartridge filters without pre-filters. Maximum bag/cartridge filter length is limited to access/plenum sections placed after this section.
 - i. Face loading HEPA (high-efficiency particulate air) bag/cartridge filters without pre-filters.

10. Coil Section:
 - a. Chilled water coil.
 - b. Direct expansion coil.
 - c. Hot water coil.
 - d. Steam coil.
 - e. Electric coil
11. Gas Heating Section.
12. Fan Section:
 - a. Horizontal draw-thru.
 - b. Horizontal blow-thru (with integral diffuser).
 - c. Plenum fan:
 - 1) With custom discharge openings on draw thru supply fans
 - 2) With optional exhaust air damper on return fans
13. Energy Recovery Wheel Section.
14. Sound Attenuator Section.

2.02 CASING

A. Construction:

1. Unit shall be constructed of a complete frame with easily removable panels. Removal of any panel shall not affect the structural integrity of the unit.
2. All units shall be supplied with a perimeter, 14-gauge or heavier, G-90 galvanized, high tensile steel base rail with a pocket to accommodate roof curb. Perimeter lifting lugs for overhead lifting shall be provided on each shipping section. Slings in place of lifting lugs shall not be acceptable.
3. Unit shall be thermally broken to minimize the conduction path from the inside of the casing to the outside.
4. Casing panels (top, sides, and bottom) shall be constructed of galvanized steel (18 gauge optional), and shall have one of the following exterior finishes as specified:
 - a. Pre-painted with a baked enamel finish passing 500-hour salt spray test (ASTM [American Society of Mechanical Engineers] B-117) for pre-painted steel and 125-hour marine level 1 cohesion test (ASTM G-85.A5) for pre-painted steel.
 - b. Unpainted G-90 galvanized steel.
5. Casing panels (top, sides, and bottom) shall be constructed of galvanized steel (18 gauge optional), stainless steel, or aluminum, and shall have one of the following interior finishes as specified:
 - a. Pre-coated galvanized steel with a silver zeolite antimicrobial material registered by the US EPA (Environmental Protection Agency) for use in HVAC applications.
 - b. Unpainted G-90 galvanized steel.

- c. Unpainted 304 stainless steel.
- d. Unpainted 3003-H14 aluminum.
- e. Option for aluminum diamond treadplate floors.
6. Roof shall be double-wall, pitched in four directions at a minimum roof slope of 1/4-in. per foot across the width of the unit. No penetrations shall be made in pressure sensitive panels. Roof shall incorporate a standing top seam. All seams in the roof shall be gasketed and capped to prevent water infiltration into the unit.
7. Casing panels (top, sides, and bottom) shall be one piece double-wall construction with foam insulation sealed between the inner and outer panels. Panel assemblies shall not carry an R-value of less than 13.
8. Casing deflection shall not exceed an L/240 ratio when subject to an internal pressure of ± 8 -in. wg and shall exhibit no permanent deformation at ± 9 in. wg L is defined as the longest linear panel or cabinet length (measured to AHRI 1350 Cd level 2).
9. Casing leakage rate shall be less than 1% at ± 8 in. wg of nominal unit airflow or 50 cfm, whichever is greater. Leakage rate shall be tested and documented on a routine basis on random production units. Optionally, factory witness leak testing and/or test reports shall be available.
10. Side panels shall be easily removable for access to unit and shall seal against a full perimeter automotive style gasket to ensure a tight seal.
11. The panel retention system shall comply with UL 60335-2-40 which states all moving parts (for example, fan blades, blower wheels, pulleys, and belts) that, if accidentally contacted, could cause bodily injury, shall be guarded against accidental contact by an enclosure requiring tools for removal.
12. Base rail shall overhang the curb to facilitate water run-off and protection of the curb to base connection from water intrusion.
13. Accessibility options shall be as follows:
 - a. Hinged, lockable double-wall access door on either side with removable access panel(s) on the other side.
 - b. Hinged, lockable double-wall access doors on both sides.
 - c. Removable double-wall access panels on both sides.
14. Depending on the options selected and the remaining available space inside each section, the following options may be available:
 - a. Reinforced glass viewports shall be factory-installed on the access panel(s) or door(s) of this section.

b. Marine lights shall be factory-installed with or without GCFI (ground fault circuit interrupter) convenience outlets.

15. Fan supports, structural members, panels, or flooring shall not be welded, unless aluminum, stainless steel, or other corrosion-resistant material is used. Painted welds on unit exterior steel or galvanized steel are not acceptable.
16. All coil sections shall be double-wall construction with foam insulation sealed between the inner and outer panels. Panel assemblies shall not carry an R-value of less than 13.
17. Blow-thru fan sections shall have a diffuser plate as an integral part of the fan section.

B. Access Doors:

Access doors shall be one piece, hinged, lockable, double-wall construction with foam insulation sealed between the inner and outer panels. Panel assemblies shall not carry an R-value of less than 13.

C. Drain Pans:

Drain pans shall be foam insulated double-wall galvanized steel (18 gauge optional) or stainless steel construction. The pan shall be sloped toward the drain connection. Drain pan shall have 1-1/2-in. MPT connection exiting through the hand side or opposite side of the casing as specified. Drain connection shall be insulated from the drain pan to the point at which it exits the casing. One drain outlet shall be supplied for each cooling coil section. Drain pan shall allow no standing water and comply with ASHRAE (American Society of Heating, Refrigerating, and Air-Conditioning Engineers) Standard 62.1-2010. Where 2 or more coils are stacked in a coil bank, intermediate drain pans shall be provided and the condensate shall be piped to the bottom drain pan. The bottom coil shall not serve as a drain path for the upper coil.

D. Roof Curbs:

1. Roof curb shall be delivered to jobsite in an unassembled, knockdown state.
2. Curb shall be constructed of 14-gauge G-90 galvanized steel, 14 in. or 24 inches in height.
3. Full perimeter wood nailers shall be securely mounted to curb sheet metal.
4. Curb channel supports will be supplied on all curbs exceeding 10 ft in total unit airway length.
5. Gasketing between curb and unit shall be shipped for field installation with the unit curb.
6. Coil connection housing curb will be offered optionally to enclose coil piping. Multiple coil connection housings may be specified (up to two per side).

E. Hoods and Louvers:

1. Outside Air Hoods:

- a. Outside air hoods shall be constructed of 20-gauge galvanized G-90 steel and sized for 100% of unit nominal cfm.
- b. Hoods shall include easily accessible 1-in. moisture eliminators with a maximum velocity of no more than 500 fpm.

2. Exhaust Air Hoods:

- a. Exhaust air hoods shall be constructed of 16-gauge galvanized G-90 steel and shipped collapsed in place.
- b. Expanded metal bird screen shall be provided to prevent entry of unwanted materials into air handler.

3. Power Exhaust Air Hood:

- a. Power exhaust air hoods shall be constructed of 18-gauge galvanized G-90 pre-painted steel.
- b. Expanded metal bird screen shall be provided to prevent entry of unwanted materials into air handler.
- c. Optional backdraft damper blades shall be 6063-T5 extruded aluminum channel with galvanized steel braces and extruded vinyl blade seals. Blades shall be mechanically fastened to axle rods rotating in corrosion-resistant, synthetic bearings. Blades begin to open at 0.12 in. wg and are fully open at 0.2 in. wg.

4. Side Intake Louvers:

- a. Frames and blades shall be 6063 alloy, 0.081 in. thick, mechanically fastened with stainless steel fasteners. Frame depth shall be 6 inches.
- b. Vertical blades shall be designed to collect and drain water to exterior at sill by means of a center rain hook and channels in jambs and mullions.
- c. Louvers shall have 1/2-in. mesh removable aluminum bird screen.
- d. Visible mullions required for louver widths greater than 96 inches.
- e. Provide sill-flashing pans 4 in. high by full depth formed from minimum 0.060 in. thick aluminum.
- f. Louvers shall be designed to withstand a wind load of 25 lb per sq ft.
- g. Water penetration shall be no more than 0.01 oz per sq ft of free area at 1250 fpm per AMCA publication 511. The AMCA test was unable to determine the beginning water penetration for this louver due to the fact that it lies above 1250 fpm through free area.
- h. Louver shall have a mill finish.

2.03 FANS

A. General:

1. Forward-curved fan sections shall have one double-width double-inlet (DWDI) fan wheel and scroll. They shall be constructed of galvanized steel with baked enamel. They shall be designed for continuous operation at the maximum rated fan speed and motor horsepower. Fans shall have an AMCA class rating corresponding to the static pressure at which the fan is designed to operate (Class I or II). Completed fan assembly shall be dynamically balanced in accordance with AHRI Guideline G and ANSI S2.19 at design operating speed using contract drive and motor if ordered.
 2. Airfoil fan sections shall have one DWDI airfoil fan wheel and scroll. Airfoil blades shall be double thickness design constructed of heavy gauge, high strength steel or aluminum continuously welded to the backplate and the spun inlet flange. Entire fan assembly shall be cleaned, primed and painted with alkyd enamel, except for an aluminum fan wheel when supplied. Fans shall have an AMCA class rating corresponding to the static pressure at which the fan is designed to operate (Class I or II). Completed fan assembly shall be dynamically balanced to minimum grade of G 6.3 per ANSI/AMCA 204 at design operating speed using contract drive and motor if ordered.
 3. Direct drive plenum fan sections:
 - a. with NEMA T frame motors shall have the option of one, two, four, or six single width single inlet (SWSI) airfoil fan wheel(s). Airfoil blades shall be double thickness design continuously welded to the back plate and the front plate. Fan wheel shall be constructed of aluminum. Airfoil blades shall be aluminum extrusions and shall be top welded to the back plate and front plate of the wheel. Fan wheel shall be dynamically balanced per ISO standard 1940 quality grade G6.3.
 - b. with EC motors shall have the option of single or multiple SWSI backward curved fans. Fan wheel shall be constructed of aluminum. Blades shall be welded to both front and back plates of the wheel. Fan assembly shall be dynamically balanced per ISO standard 1940 quality grade 6.3.
 4. Isolated fan assembly vibration shall not exceed 0.248 in. per second when mounted on active isolators. Vibration shall be measured in both vertical and horizontal directions at the specified fan operating speed using specified motor. For testing purposes, accelerometers shall be mounted on the motor near the bearing locations and removed before shipment.
 5. All fan sled components shall provide corrosion protection to pass 100-hour salt spray test per ASTM B-117.
 6. Fan wheels for all AF, FC, and direct drive PF with NEMA “T” frame motors shall be keyed to the shaft. Fan wheels for direct drive PF with EC motors shall be mounted directly to the rotor of the EC motor. All shall be designed for continuous operation at maximum rated fan speed and motor horsepower. Fan wheels and shafts shall be selected with a maximum operating speed 25% below the first critical.
 7. Belt drive fan motor shall be mounted within the fan section casing on slide rails equipped with adjusting screws. Belt drive and direct drive with NEMA “T” frame motors shall be premium efficiency, open drip-proof or totally enclosed fan cooled NEMA (National Electrical Manufacturers Association) Design A or B with size and electrical characteristics as shown on the equipment schedule. Motor shall be mounted on a horizontal flat surface and shall not be supported by the fan or its structural members. All three-phase motors shall have a $\pm 10\%$ voltage utilization range and a 1.15 minimum service factor. Motor shall be compliant with the Energy Independence and Security Act (EISA) of 2007 where applicable. Single-phase motors shall be available up to and including 5 hp.
 8. Direct drive with EC motors shall exceed the minimum efficiency requirements of the ErP Directive for Fans, efficiency class IE4, and specify motor protection according to EN 60529. Motors shall also provide the following: locked rotor protection, phase failure detection, soft start, mains under-voltage detection, over-temperature protection of electronics/motor, and short circuit protection.
- B. Performance Ratings:
Supply fan performance shall be rated and certified in accordance with AHRI Standard 430.
- C. Sound Ratings:
Manufacturer shall submit first through eighth octave sound power for fan discharge and casing radiated sound. Sound ratings shall be tested in accordance with AHRI 260.
- D. Mounting:
1. AF, FC, Direct-drive PF with NEMA motor: Fan scroll, wheel, shaft, bearings, drives, and motor shall be mounted on a common base assembly. The base assembly is isolated from the outer casing with factory-installed isolators and vibration absorbent an discharge seal. A canvas style duct connection between fan discharge and cabinet is not acceptable. Units shall use 2-in. deflection spring isolators.

2. Direct drive PF with EC motor: Fan wheel, inlet plate, inlet ring, motor and motor supports shall be a common assembly. The assembly is mounted directly to panels on an internal bulk-head wall.
- E. Fan Accessories:
1. Forward curved fans:
 - a. Variable frequency drives with or without bypass.
 - b. Magnetic motor starters.
 - c. Motor disconnects.
 - d. Airflow measuring piezo ring.
 - e. Piezo ring transducer.
 - f. Motor shaft grounding ring.
 - g. Belt guards.
 - h. Inlet screen.
 2. Airfoil fans:
 - a. Variable frequency drives with or without bypass.
 - b. Magnetic motor starters.
 - c. Motor disconnects.
 - d. Airflow measuring piezo ring.
 - e. Piezo ring transducer.
 - f. Motor shaft grounding ring.
 - g. Belt guards.
 - h. Inlet screen.
 3. Direct Drive Plenum Fans with NEMA “T” frame motors:
 - a. Variable frequency drives.
 - b. Motor protection box for motor current protection with a single VFD driving multiple motors.
 - c. Airflow measuring piezo ring.
 - d. Piezo ring transducer.
 - e. Motor shaft grounding ring.
 - f. Inlet guard.
 - g. Blank off plate.
 - h. Backdraft Dampers
Optional backdraft damper blades shall be 6063-T5 extruded aluminum channel with galvanized steel braces and extruded vinyl blade seals. Blades shall be mechanically fastened to axle rods rotating in corrosion-resistant synthetic bearings. Blades begin to open at 0.12 in. wg and are fully open at 0.2 in. wg.
 4. Flexible Connection:

The base assembly is isolated from the outer casing with factory-installed isolators and vibration absorbent fan discharge seal. A canvas style duct connection between fan discharge and cabinet is not acceptable.
 5. Direct Drive Plenum Fans with EC Motors
 - a. Corrosion protection
 - b. Inlet guard
 - c. Blankoff plate
 - d. Backdraft dampers
 - e. Control options
 - 1) 0-10 VDC
 - 2) 4-20 mA
 - 3) Modbus
 - 4) BACnet

2.04 BEARINGS AND DRIVES

A. Bearings:

Self-aligning, grease lubricated, anti-friction with lubrication fittings extended to drive side of fan section. Optional grease fittings extended to the exterior of the casing are available. All bearing life calculations shall be done in accordance with ABMA 9 for ball bearings and ABMA 11 for roller bearings.

1. Size 03 to 110 forward-curved fans: Cartridge type bearings for Class I fans. Heavy-duty pillow block type, self-aligning, regreasable ball or roller type bearings selected for a minimum average life (L50) of 200,000 hours or optionally for an (L50) of 500,000 hours.
2. Size 03 to 110 airfoil fans: Heavy-duty pillow block type, self-aligning, regreasable ball or roller type bearings selected for a minimum average life (L50) of 200,000 hours or optionally for an (L50) of 500,000 hours.

B. Shafts:

Fan shafts shall be solid steel, turned, ground, polished and coated with a rust inhibitor.

C. V-Belt Drive:

Drive shall be designed for a minimum 1.2 service factor as standard with a 1.5 service factor option and/or a factory-supplied extra set of belts. Drives shall be fixed pitch with optional variable pitch for motors 15 hp and less. All drives shall be factory

2.05 COILS

- A. All water, steam and direct expansion (DX) refrigerant coils shall be provided to meet the scheduled performance. All coil performance shall be certified in accordance with AHRI Standard 410. All water and direct expansion coils shall be tested at 450 psig air pressure. Direct expansion coils shall be designed and tested in accordance with ANSI/ASHRAE 15 Safety Code for Mechanical Refrigeration (latest edition). Factory-supplied 1/2-in. OD coils shall be covered under the standard product one-year limited warranty. All steam coils, integral face and bypass coils and 5/8-in. OD coils shall be warranted for a period not in excess of 12 months from their shipment from the manufacturer. Coil epoxy coating shall be covered under a 5-year limited warranty from the date of shipment from the manufacturer.
- B. General Fabrication:
1. All water and refrigerant coils shall have minimum 1/2-in. OD copper tubes mechanically expanded into fins to ensure high thermal performance with lower total flow and pumping requirements. Minimum tube wall thickness shall be 0.016 inches. Optional tube wall thickness of 0.025 in. shall be supplied, if specified.
 2. Optionally, water coils shall have minimum 5/8-in. OD copper tubes mechanically expanded into fins to ensure high thermal performance with lower total flow and pumping requirements. Minimum tube wall thickness shall be 0.020 inches. Optional tube wall thickness of 0.035 in. shall be supplied, if specified.
 3. Aluminum plate fin type with belled collars available from 8 to 14 fins per inch in one fin per inch increments. Optional copper plate fins shall be supplied, if specified. Fin type shall be sine wave construction.
 4. Aluminum-finned coils shall be supplied with die-formed casing and tube sheets of mill galvanized steel or stainless steel as specified. Copper-finned coils shall be supplied with stainless steel casing and tube sheets.
- C. Hydronic Heating and Cooling Coils:
1. Headers shall be constructed of steel with steel MPT connections. Headers shall have drain and vent connections accessible from the exterior of the unit. Optional non-ferrous headers and red brass MPT connections shall be supplied if specified.
 2. Configuration: Coils shall be drainable, with non-trapping circuits. Coils will be suitable for a design working pressure of 300 psig at 200°F.
- D. Steam Distribution (Non-Freeze Type) Heating Coils:
1. Headers shall be steel with MPT connections.
 2. Inner steam distributing tubes shall be 5/8-in. OD, 0.020 in. wall thickness, located within 1 in. OD, 0.030 in. wall outer condensing tubes. Working pressure shall be 175 psig at 400°F.
 3. Inner steam distributing tubes shall be 3/8-in. OD, 0.020 in. wall thickness, located within 5/8-in. OD, 0.035 in. wall outer condensing tubes. Working pressure shall be 175 psig at 400°F.
- E. Integral Face and Bypass Coils:
1. Sizes 03-14 shall have horizontal steam or hot water coils with a tubewall thickness of not less than 0.020 inches. Tubes shall be mechanically expanded into die formed collars formed in aluminum plate type fins.
 2. Sizes 17-110 shall have vertical steam or hot water coils with a tubewall thickness of not less than 0.035 inches. Fins shall be spiral edge-wound copper. Tubes shall be free-floating for thermal expansion and contraction without the use of offset bends or floating headers.
- F. Refrigerant Coils:
1. Headers shall be constructed of copper with brazed joints.
 2. Brass refrigerant distributors and seamless copper distribution tubes shall be factory supplied to ensure uniform flow.
 3. Thermal expansion valves (TXV) and nozzles shall be factory installed and piped to the exterior of the casing. Equalizer lines shall be piped internal to the coil header.
 4. Suction and liquid line pairs shall be located next to each other for easy circuit identification. A custom label showing TXV size, nozzle size and condensing unit circuit pairing shall be located on the side of the coil section.
 5. Standard circuiting selections include:
 - a. Single distributor arrangement for sizes 03-17.
 - b. Row split intertwined multiple distributor arrangement for sizes 03-110.
 - c. Face split multiple distributor arrangement for sizes 03-110.
 6. Coils selected with R-32 or R-454B (A2L refrigerants) shall be equipped with a refrigerant leak detection system which will include a dissipation board and refrigerant sensor(s) mounted within the refrigerant coil section and wired back to the motor starting device (if equipped).
 7. Submittals must include a DX coil and condensing unit cross plot to show that the coil and condensing unit capacity match at the rated design conditions.

G. Electric Heating Section:

1. The electric heater casing is constructed of galvanized steel. Heater control box access door shall be mounted on the designated hand side of the unit. Element construction as follows:
 - a. Open-wire type, 80% nickel, 20% chromium resistance coils, insulated by Steatite bushings and supported in a galvanized steel frame. Bushings shall be recessed into embossed openings and stacked into supporting brackets, spaced no more than 4-in. centers. Thermal cutouts for overtemperature protection shall be provided to meet UL and NEC requirements. Maximum element heating density shall be 55 watts/sq inch.
 - 1) Contactor control - electric heaters up through 60 kW shall have 3 stages of control, beyond 60 kW shall have 6 stages of control.
 - 2) SCR control - electric heaters up through a maximum of 90 amps are available with full SCR control. The entire heater is modulated to achieve the proportional control based on a 0 to 10 volt DC or 4 to 20 mA control signal.
 - 3) Vernier control - the heater has full modulating control of the first circuit of heat, all of which is rated at equal kW increments. There is a minimum of 3 circuits for this type of control. These stage increments are turned on and off by a step controller. As each stage fulfills the demand for heat, the SCR increment is used as a fully modulating filler between stages. This end output is a fully proportional control of the electric heater based on a 0 to 10 volt DC or 4 to 20 mA control signal.
 - b. Sheathed type, 80% nickel, 20% chromium resistance coils, suspended in a magnesium oxide insulator fill within a tubular steel sheath/brazed fin assembly. Silicone rubber end seals shall prevent contamination of the interior, and the exterior shall be protected from corrosion by a high temperature aluminum coating. Thermal cutouts for overtemperature protection shall be provided to meet UL and NEC requirements. Maximum element heating density shall be 55 watts/sq inch.
 - 1) Contactor control - electric heaters up through 60 kW shall have 3 stages of control, beyond 60 kW shall have 6 stages of control.
2. The manufacturer shall furnish an integral control box containing thermal cutouts, primary control, subcircuit fusing, airflow switch, and fused control transformer.

3. Electric heaters shall be UL listed for zero clearance and shall meet all applicable National Electric Code requirements.
4. Units with electric heat sections shall be listed under UL 60335-2-40 Standard for Safety.

2.06 GAS HEATING SECTION

- A. Indirect fired gas furnace section(s) shall have a minimum thermal efficiency of 81% and incorporate agency listed gas-fired duct furnace(s) per UL, CSA, or ETL for operation on natural or propane gas to the current edition of ANSI Z83.8 or Canadian CSA 2.6 Standard for Gas-Fired Duct Furnaces. Duct furnaces shall be installed on the positive pressure side of the supply fan only.
- B. The duct furnace modules shall have:
 1. 20 gauge galvanized steel heat exchanger cabinet.
 2. 1 in. thick, minimum 1-1/2 lb per cu ft density thermal insulation for the heat exchanger cabinet.
 3. Each furnace shall have an induced-draft fan for the removal of flue gases and to keep the heat exchanger at a negative pressure.
 4. Air pressure switches to prove air supply for combustion before operation of gas valve.
 5. Patented inshot gas burners with integral carryovers.
 6. Direct-spark ignition of the gas burners with remote flame sensor to prove carryover across all burners.
 7. A listed 24-vac redundant combination gas valve including two electric shutoff valves, gas pressure regulator, and a manual shutoff valve per furnace.
 8. An automatic reset type high limit switch to limit maximum outlet air temperature to less than 250°F.
 9. Manual reset flame rollout switches.
 10. Minimum of one 40 va, 24 vac control transformer.
 11. 1/8 in. NPT tapped test gauge connection in the gas manifold for measuring gas pressure.
 12. Union fitting downstream of gas control to facilitate installation and service.
 13. Provision for attachment of a vent system to exhaust flue gases to the outdoors.
- C. Gas-fired duct furnace(s) provided shall have an 18 gauge tubular heat exchanger assembly suitable to withstand 3.0 in. wg total external static pressure without burner flame disturbance and constructed of either:
 1. Type 409 stainless steel (0.044 minimum wall thickness) produced to ASTM A268.
 2. Type 304L stainless tubes (0.047 minimum wall thickness) produced to ASTM A249.

- D. Gas heating section modules shall be listed for application downstream of refrigeration and cooling systems and shall provide means for removal of condensate that occurs in the tubes during cooling operation. Heat exchanger tubes shall have (integral formed dimpled restrictors; formed tubulators) to provide for an unobstructed drainage path and tubes shall be formed to provide a positive pitch to promote condensate drainage. Drainage shall be configured so that burners and burner surfaces are not exposed to condensate.
 - E. Gas heating section shall incorporate a direct-spark ignition control module listed by one of the following: US, CSA, or ETL.
 - F. Controls shall provide:
 - 1. 100% safety shutoff.
 - 2. A 15-second minimum pre-purge period prior to trial for ignition.
 - 3. High-energy direct-spark ignition of main burners.
 - 4. Electronic flame supervision incorporating a 0.8-second flame failure response time.
 - 5. Up to 2 additional ignition retries preceded by an inter-purge period.
 - 6. A minimum 30-second post-purge.
 - 7. Automatic reset after one hour to initiate additional ignition trials if lockout occurs during heat call.
 - 8. An LED indicator light to provide a flash code to identify the operating condition of the control.
 - G. Gas heating section shall be equipped for operation with 115 vac, single-phase, 60 Hz power supply.
 - H. All electrical components shall be listed or recognized by UL, CSA, or ETL.
 - I. Gas Furnace Control:
 - 1. Single furnace — Operates from 10 to 100% of input from a single analog input of 0 to 10 vdc.
 - 2. Two furnaces in series — Lead unit operates from 20 to 100% of input and secondary unit operates in two-stage operation to achieve overall system input of 10 to 100% from a single analog input of 0 to 10 vdc.
 - 3. Furnace rack systems — Multiple furnaces operate from a single analog input of 0 to 10 vdc with a lead modulating furnace and multiple secondary two-stage furnaces to achieve overall system input of 10 to 100%. (10:1 turndown minimum; most rack systems provide greater than 10:1 turndown.)
 - J. Electronic modulation — Operates from 10 to 100% of input from a single analog input of 0 to 10 vdc. Heat enable contact (supplied by others) initiates and ends heating cycles. Heating unit incorporates two-speed operation of combustion air blower and two-stage gas valve, signal amplifier and timer relay control.
 - K. Gas supply pressure to the gas valve inlet shall be 6.0 to 13.5 in. wg for natural gas or 11.0 to 12.0 in. wg for propane gas.
 - L. Units are orificed for operation up to 2000 ft above sea level unless specified for high altitude operation.
 - M. Duct furnaces shall be test-fired prior to shipment to verify proper ignition, operation and shutdown and satisfactory operation of all components.
 - N. Furnaces shall be provided with printed installation and maintenance instructions, burner operating and maintenance instructions, piping and wiring diagrams and installation start-up data sheet.
- ## 2.07 ENERGY RECOVERY WHEEL
- A. Construction:
 - 1. Wheel sections shall incorporate a rotary wheel in an insulated cassette frame complete with seals, drive motor and drive belt.
 - 2. The wheel shall be coated with silica gel desiccant, permanently bonded without the use of binders or adhesives.
 - 3. The substrate shall be made of a light weight polymer and shall not degrade nor require additional coatings for application in coastal environments.
 - 4. Coated wheel segments shall be washable with detergent or alkaline coil cleaner and water.
 - 5. The silica gel desiccant shall not dissolve nor deliquesce in the presence of water or high humidity.
 - 6. The wheel polymer layers shall be wound continuously with one flat and one structured layer in an ideal parallel plate geometry providing laminar flow and minimum pressure drop.
 - 7. The wheel shall incorporate the channel matrix design and an optional adjustable mechanical purge.
 - 8. The polymer layers shall be captured in a stainless steel wheel frame or aluminum and stainless steel segment frames that provide a rigid and self-supporting matrix.
 - 9. Energy recovery wheels greater than 25 inches in diameter shall be provided with removable wheel segments.
 - 10. Wheel frame shall be a welded hub, spoke and rim assembly of stainless, plated and/or coated steel and shall be self-supporting without the wheel segments in place.
 - 11. Wheel segments shall be removable without tools to facilitate maintenance and cleaning.
 - 12. Wheel bearings shall provide an L-10 life in excess of 400,000 hours.
 - 13. Wheel rim shall be continuous rolled stainless steel and the wheel shall be connected to the shaft by means of taper locks.
 - 14. All diameter and perimeter seals shall be provided as part of the cassette assembly and shall be factory set.

15. Drive belts of stretch urethane shall be provided for wheel rim drive without the need for external tensioners or adjustment.
16. The energy recovery section shall be a UL recognized component for electrical and fire safety. The wheel drive motor shall be UL recognized and mounted in the cassette frame and supplied with a service connector or junction box.
17. Thermal performance shall be AHRI Standard 1060 certified and bear the AHRI Certified Product Seal. Cassettes shall be listed in the AHRI Certified Products Directory and bear the AHRI Certified Product Seal.
18. Wheel shall carry a 5-year parts warranty. This warranty is for all wheel cassette components except the drive motor, which carries the motor manufacturer's warranty.

2.08 HUMIDIFIERS

- A. The humidifiers shall be of the direct discharge type, using steam from existing steam lines or boilers to be injected into the air plenums for humidification.
- B. Each humidifier shall consist of multiple, vertical steam discharge pipes, supported on horizontal header manifolds, spaced to provide the optimum of steam to air contact while minimizing pressure drop. Each humidifier shall be sized to nominally match the air plenum width and height for maximum contact of the discharging steam to the air passing around the vertical steam discharge pipes.
- C. The vertical steam discharge pipes shall be constructed of 316 stainless steel. Each pipe shall have a full-length, inverted slot on each side for steam discharge at 100% air to steam contact. Nozzles and holes have less than 15% air to steam contact and are, therefore, unacceptable.
- D. A full-length stainless steel fishbone shaped baffle shall be used inside the vertical discharge pipe to wick condensate away from the discharge slots and back to the center of the pipe for re-evaporation.
- E. The feeder manifolds shall be constructed of 316 stainless steel, sized to move the steam in a specific mass-flow speed range, for maximum condensate separation. Final condensate separation shall occur inside the feeder manifolds, after the control valve, with the dried steam then injected directly into the vertical discharge pipes.
- F. Insulated uprights provide a cushion of air that reduces both heat gain and condensate formation. Insulated models have nozzles inserted in the uprights to ensure that only dry steam is delivered into the air.
- G. The steam humidifier shall be designed with slip fittings for easy assembly. The steam humidifier shall be designed without plastic nozzles, collars, o-rings or gaskets for zero maintenance.

2.09 FILTER SECTIONS

- A. Flat filter sections shall accept either 2-in. or 4-in. filters. Sections shall include side access slide rails. Optional 2 in. pre-filter shall be available.
- B. Angle filter sections shall accept either 2-in. or 4-in. filters of standard sizes, arranged in a horizontal V formation.
- C. Draw-thru bag/cartridge filter sections shall be capable of accepting headered standard size 6-in. to 12-in. deep rigid media or bag filters and a 2-in. pre-filter.
- D. Draw-thru bag/cartridge filter sections shall be capable of accepting headered standard size 12-in. to 30-in. deep rigid media or bag filters and a 2-in. pre-filter.
- E. Blow-thru bag/cartridge filter sections shall contain a face loading filter frame and be capable of accepting standard size 12-in. deep rigid media (headered or box) or bag filters.
- F. Blow-thru HEPA filter sections shall contain a face loading filter frame and be capable of accepting standard size 12-in. deep HEPA box filters.
- G. Differential Pressure Gauges:
 1. Housing shall be constructed of a glass filled nylon case and acrylic lens. Exterior finish shall be coated black.
 2. Accuracy shall be $\pm 5\%$ of full scale throughout range at 70°F.
 3. Pressure limits shall be 30 psig continuous to either pressure connection.
 4. Temperature limits shall be 20 to 120°F.
 5. Diameter of dial face shall be 2.33 in.
 6. Process connections shall be barbed, 3/16-in. for ID tubing.

2.10 Sound Attenuators:

- A. Factory-supplied sound attenuators (silencers) shall be fabricated from solid and perforated sheet metal. Internal splitters (baffles) shall be filled with acoustic-grade inorganic glass fiber to absorb sound power. Perforated metal faces shall protect the glass fiber from airflow erosion.
- B. Insertion loss sound ratings shall be stated in accordance with AHRI 260, and pressure-drop data shall follow ASTM E477.
- C. Standard Construction Features:
 1. Galvanized casing lock-formed construction in accordance with SMACNA requirements.
 2. 1 inch slip connection provided at each end.
 3. Aerodynamically shaped nose at the inlet to minimize turbulence.
 4. Splitters with a perforated diffuser tail. Acoustic media shall be installed at no less than 15% compression to maintain uniform density.

2.11 DAMPERS

- A. Factory-supplied dampers shall be warranted to be free from defects in material and workmanship for a period of 12 months after being installed or placed in service, but in no instance shall the period of warranty be longer than 18 months from the date of the original shipment by the manufacturer.
- B. Mixing boxes, filter-mixing boxes, and exhaust boxes shall have parallel or opposed blades and interconnecting outside-air and return-air dampers. Bottom damper locations shall be optionally available with a tool screen to prevent most objects from falling through a bottom damper opening.
1. Standard Dampers:
Damper blades shall be constructed of galvanized steel, with blade seals and stainless steel jamb seals. Blades shall be mechanically fastened to axle rods rotating in self-lubricating synthetic bearings. Maximum leakage rate shall be 4 cfm/ft² at 1 in. wg differential pressure.
 2. Premium Dampers:
Damper blades shall be constructed of galvanized steel with a double-skin airfoil design, with blade seals and stainless steel jamb seals. Blades shall be mechanically fastened to axle rods rotating in self-lubricating synthetic bearings. Maximum leakage rate shall be 2 cfm/ft² at 1 in. wg differential pressure.
 3. Outside Air Measurement Dampers:
 - a. Damper frame shall be nominal 4 in. x 1 in. x minimum 0.081 in. and constructed of 6063-T5 extruded aluminum.
 - b. Airflow measuring blades shall be airfoil-shaped, heavy gauge anodized 6063-T5 extruded aluminum and fixed in 10 in. x minimum 16 gauge galvanized steel frame.
 - c. Jamb seals shall be flexible metal compression type along control damper sides.
 - d. Blade seals shall be neoprene along control damper blade edges.
 - e. Bearings shall be molded synthetic.
 - f. Linkage shall be galvanized steel, concealed in frame.
 - g. Axles shall be minimum 1/2-in. diameter plated steel, hex-shaped, mechanically attached to blade.
 - h. Operating temperature shall be -22 to 140°F.
 - i. Air straightener section shall be aluminum alloy honeycomb contained in 5 in. long, 16 gauge galvanized steel sleeve attached to monitoring blade frame.
 - j. Airflow range shall be 400 to 5,000 ft per minute face velocity.
 - k. Maximum leakage rate shall be 2 cfm/ft² at 1 in. wg differential pressure.
- C. Integral Face and Bypass Dampers:
1. Integral face and bypass (IFB) coils shall be capable of maintaining a constant air volume, within 5%, shall be capable of maintaining a constant leaving air temperature as entering air conditions vary, and shall be capable of producing mixed leaving air temperatures within 3 ft downstream with a maximum variance in air temperature of 5°F, regardless of damper position.
 2. When no heating is required, dampers shall divert air to bypass around heating surface with minimal temperature override.
 3. Coil casing, dampers and baffles shall be fabricated from galvanized steel with an option for stainless steel. Coils shall be tested at 300 psig.
 4. Integral face and bypass coils shall be provided with a connection point for field-mounted actuator(s), electrical or pneumatic, or can be provided from the factory at an additional cost.
 5. Actuator connection point shall be mechanically attached to dampers via linkage mechanisms. Dampers shall be interconnected for operation simultaneously across each face of coil.
- D. Internal Face and Bypass Dampers:
Internal face and bypass dampers shall be factory mounted in galvanized steel frame. Damper blades shall be constructed of galvanized steel, with high temperature blade and edge seals. Blades shall be mechanically fastened to axle rods rotating in self-lubricating synthetic bearings. To eliminate blade warping, face dampers shall be sectionalized to limit blade length to 60 in. maximum. Face damper blades shall be opposed and arranged to match coil face with top bypass, and internal linkage.

E. Power Exhaust Hood Dampers:

Backdraft damper blades shall be 6063-T5 extruded aluminum channel with galvanized steel braces and extruded vinyl blade seals. Blades shall be mechanically fastened to axle rods rotating in corrosion-resistant, synthetic bearings. Blades begin to open at 0.12 in. wg and are fully open at 0.2 in. wg.

F. Smoke Damper

Smoke Dampers shall be factory mounted only available in the return air opening on mixing boxes and filter-mixing boxes.

1. UL555S Classified.
2. Rated up to 4000 fpm and 8 in. wg.
3. Equipped with a factory-furnished actuator that provides fail-safe operation (the damper automatically moves to the designated fail-safe position when fire interrupts power).
4. Airfoil blades, offering greater strength, lower static pressure, superior sealing, enhanced fire protection, and reduced noise.
5. Horizontal dampers shall be constructed of galvanized steel. Vertical dampers shall also be galvanized steel, except when height exceeds 39 inches, in which case they shall be constructed of aluminum.

2.12 AIR MIXING SECTION

A. KEES Air Mixer®¹

Air mixer of 0.081-in. aluminum construction of size, performance and maximum pressure drop indicated. The air mixer shall mix two or more airstreams of differing temperature to within $\pm 6^{\circ}\text{F}$ of theoretical mixed-air temperature and provide a more uniform air velocity contour entering a downstream filter or coil bank.

B. Blender Products Series IV Air Blender®¹

Static mixing devices of a minimum 0.080 in. aluminum welded and mechanical fastened construction shall be installed where shown to enhance the mixing of outside air with return air to a desired mixing effectiveness and provide even airflow across filters, coils and control sensors. When combined with a typical mixing box the mixing section shall provide a Mixing Effectiveness of 65% with a minimum outdoor air percentage of 30%. Air mixer models shall be geometrically scaled to ensure proper performance across full range of applications. Mixers that are not geometrically scaled are not acceptable.

2.13 UV-C GERMICIDAL LAMPS

- A. Emitters and fixtures for UV-C lamps shall be designed for use inside an HVAC system and shall be covered by a 1 year warranty. Individual lamp output shall be measured in an ASME nozzled test apparatus using a 45°F airstream moving at not less than 400 fpm. Lamp output at 253.7 nm shall not be less than 10 $\mu\text{W}/\text{cm}^2$ per inch of arc length measured at a distance of one meter.
- B. Power supplies for UV-C lamps shall be a high-efficiency electronic type which are matched to the emitters and are capable of producing the specified output intensity with an input power no more than 80 watts.
- C. Fixtures for UV-C lamps shall be factory installed and wired to a SPDT disconnect switch and door interlock switches in each door. Fixtures are wired for 120 v/single ph requiring a minimum circuit ampacity of 15 amps. Lamps shall ship separately for field installation to minimize the chance for bulb damage.
- D. Emitters and fixtures shall be installed in sufficient quantity and arranged so as to provide an equal distribution of UV-C energy on the coil and drain pan.
- E. The minimum UV-C energy striking the leading edge of the coil pan shall be not less than 450 $\mu\text{W}/\text{cm}^2$ at the closest point and through placement, not less than 60% of that value at the farthest point. Equal amounts are to strike the drain pan, either directly or indirectly through reflection.
- F. Emitters and fixtures shall be installed such that UV-C energy strikes all surfaces of the coil, drain pan, and the available line of sight airstream.

2.14 ELECTRICAL ACCESSORIES

A. ECM Power Distribution Panel

1. Power distribution panel shall be enclosed in a NEMA 4 electrical box and shall be included with every fan section which has an ECM fan array.
2. A single line of sight disconnect for the entire fan array shall be located on the outside of the electrical box.
3. Individual circuit breakers for each fan shall be mounted on the power distribution panel to isolate each fan for service. Fans shall be factory wired back to the power distribution panel.
4. Control wiring from all fans in the array shall terminate at one point inside the power distribution panel to control the entire array. Control signal shall be wired as 0-10 volt and shall include a field installed resistor if 4-20 mA control is required.
5. BACnet or Modbus shall be available as an option. When selected, all motors shall be factory addressed.

1. Third-party trademarks and logos are the property of their respective owners.

6. A high Short-Circuit Current Rating (SCCR) option is available for ECM fan arrays with 12 or fewer fans:
 - a. 65 kA for V systems
 - b. 100 kA for 208-230 V systems

B. Single Point Power:

The single point power (SPP) box shall have an externally mounted, complete unit line of site disconnect. Internally, the single point power box shall have individual circuit breakers for each circuit, allowing individual circuit protection and a means of disconnect while not completely disabling the unit. SPP box locations shall be offered as:

- a. Single Point Power Right Side Mount
- b. Single Point Power Left Side Mount
- c. Single point Power End Mount

1. Single Point Power Enclosure:

- a. Enclosure supplied shall have appropriately sized circuit breakers, fusing, wiring, labeling and penetrations based on the unit configuration.
- b. Enclosure shall be equipped with a lockable door and a NEMA extended rotary handle mechanism on the enclosure door to provide a means for external disconnect operation to the main circuit breaker switch within the SPP enclosure.
- c. Enclosure to be SCE “EnviroLine” NEMA 4 steel or equivalent.
- d. Enclosure to be suitable for both indoor and outdoor applications and shall operate within temperature limits of -20°F to $+140^{\circ}\text{F}$.
- e. All SPP assemblies shall comply with UL 508 and be labeled as compliant.
- f. Wiring penetrations shall be pre-punched in the back of the enclosure and enter the inside of the air handling unit through strain reliefs. Enclosure shall be gasketed and sealed to the panel it is mounted to.
- g. A single 120 volt GFCI outlet shall be mounted on the enclosure when at least one marine light, convenience outlet, UV-C section or controls section is selected.
- h. Internal components (i.e., fuse blocks, circuit breakers) shall be labeled with the appropriate circuit identification.
- i. Enclosure assemblies supplied with fuses shall have a label affixed that provides replacement fuse identification.
- j. All enclosures shall have the following labels adhered to the inside of the enclosure door: UL 508 labeling, amperage and voltage rating, maximum overcurrent protection rating.

2. Transformer:

- a. Single phase resin filled.
- b. Low voltage transformer to be Square D or equivalent.
- c. NEMA 3R enclosure rating.
- d. Stepdown shall be one of the following:
 - 1) 240/480 volt primary to 120/240 volt secondary 60 Hz
 - 2) 600 volt primary to 120/240 volt secondary 60 Hz
 - 3) 190/200/208/220 or 380/400/416/440 volt primary to 110/220 volt secondary 50/60 Hz.

3. Wiring and Harnesses:

- a. Wiring harnesses shall be specifically designed for the unit configuration. Generic wiring harnesses are not acceptable.
- b. Wire assemblies shall be thermoplastic heat resistant nylon coated (THHN) stranded copper (90°C) or AWM wire. All wires used shall be moisture resistant. Conductors shall be bundled and sleeved with heat-shrink material over connector end and sleeve. All colored electrical tape for wire marking shall be “3M Super 35 electrical tape”. For readability, laser print to be black on white background, smudge and wear resistant for life of wire assembly. The crimping of connectors to wires and the assembly of connectors to contactors shall follow manufacturer’s instructions.
- c. Wiring harnesses shall have polarized plugs that can only be assembled one way. Plugs shall have the ground lug identified by a green connector, while all of the powered lugs shall be black.
- d. If a shipping split is inserted in the unit configuration, a label shall instruct the assembler to connect the single point wiring harness before the two unit sections are mated. Each wiring harness shall extend at least 12 in. from each shipping split to allow the harnesses to be mated.

C. Marine Lights and Convenience Outlets:

1. Cast, non-ferrous metal, weatherproof, fixture.
2. Cast, non-ferrous metal, weatherproof, electrical junction box.
3. Gasketed, heat and shock resistant glass globe protects against moisture and debris.
4. Cast, non-ferrous metal lamp guard to protect glass globe.
5. UL and CSA listed.
6. 100 watt type ‘A’ lamp maximum capacity.
7. Each fixture is equipped with a 9.5 watt, 120 volt, 800 lumen LED lamp with an average rated life of 25,000 hours, factory installed.

8. Cast, non-ferrous metal, single gang, weather-proof, switch enclosure.
 9. With convenience outlet: Factory supplied and wired, SPST, toggle switch and 15 amp, 120 vac/60 Hz, NEMA 5-15 type, ground fault circuit interrupt (GFCI) receptacle, weatherproof, 'In-Use' type, lockable cover, UL listed.
 10. Without convenience outlet: Factory supplied and wired, SPST switch with non-ferrous metal, weatherproof cover plate, UL listed.
 11. Each fixture is factory wired to an externally mounted switch box. (Field power connections are made to the switch box mounted externally on the unit.)
 12. All factory wiring penetrating through the panel is protected in 'RIGID' type metal conduit.
- D. Disconnects:
- Factory-supplied disconnects shall be covered under a 1 year limited warranty from the manufacturer from the date of shipment.
1. 115-230 volt/single-phase non-fused disconnects shall have the following characteristics:
 - a. Plated current carrying components for superior corrosion protection.
 - b. Factory-installed equipment grounding terminals with slot/square drive screws.
 - c. Rated for motor disconnect applications (10 hp maximum).
 - d. NEMA type 3R non-metallic enclosure.
 - e. Up to 10,000 rms symmetrical amperes SCCR, when protected by a fuse or circuit breaker rated 60 amperes or less.
 - f. Cover padlock hasp.
 - g. Pull-out cartridge type.
 - h. UL listed.
 2. 115-230 volt/single-phase fused disconnects shall have the following characteristics:
 - a. Visible blades.
 - b. Quick-make, quick-break operating mechanism.
 - c. Cover padlock hasp and handle lock "OFF."
 - d. 240 vac maximum.
 - e. Factory supplied and installed class RK5 fuses.
 - f. Up to 100,000 rms symmetrical amperes SCCR, utilizing appropriately rated, factory supplied, Class R fuses.
 - g. Horsepower rated for motor applications.
 - h. Tangential combination knockouts for field wiring.
 - i. Spring reinforced plated copper fuse clips.
 - j. NEMA type 3R enclosures.
 3. 200-230 volt/3-phase fused and non-fused disconnects shall have the following characteristics:
 - a. Visible blades.
 - b. Quick-make, quick-break operating mechanism.
 - c. Cover padlock hasp and handle lock "OFF."
 - d. 240 vac maximum.
 - e. Factory supplied and installed class RK5 fuses (fused disconnects only).
 - f. Up to 100,000 rms symmetrical amperes SCCR, utilizing appropriately rated Class R fuses.
 - g. Horsepower rated for motor applications.
 - h. Tangential combination knockouts for field wiring.
 - i. Spring reinforced plated copper fuse clips.
 - j. NEMA type 3R enclosures.
 - k. Insulated, bondable solid neutral assemblies.
 - l. UL listed, File E2875.
 - m. Meet or exceed NEMA KS1-1990.
 4. 380-575 volt/3-phase fused and non-fused disconnects shall have the following characteristics:
 - a. Visible switch blades with for positive "OFF" indication.
 - b. Quick-make, quick-break operating mechanism.
 - c. Dual cover interlock.
 - d. Color coded "ON" — "OFF" indicator handle.
 - e. Cover padlock hasp and handle lock "OFF" provision for multiple padlocks.
 - f. 600 vac maximum.
 - g. Factory supplied and installed class RK5 fuses (fused disconnects only).
 - h. Up to 200,000 rms symmetrical amperes SCCR, utilizing appropriately rated Class R fuses.
 - i. Horsepower rated for motor applications.
 - j. Spring reinforced plated copper fuse clips.
 - k. Tangential combination knockouts.
 - l. NEMA type 3R enclosures.
 - m. Insulated, bondable solid neutral assemblies.
 - n. Wire terminations suitable for aluminum or copper conductors.
 - o. UL listed.
 - p. Meet or exceed NEMA KS1-1999.

E. Starters:

Factory-supplied disconnects shall be covered under a 1 year limited warranty from the manufacturer from the date of shipment.

1. Starter without disconnect:

- a. Adjustable motor overload with trip indication.
- b. Manual overload reset button (accessible without opening enclosure).
- c. 115-v fused secondary control transformer (fuse included — fused primary and secondary over 50 amps).
- d. Hand/Off/Auto selector switch (accessible without opening enclosure).
- e. Separate 4-position terminal strip for remote H-O-A wiring.
- f. C series contactors.
- g. Horsepower rated for motor applications.
- h. NEMA 4 or higher enclosures.
- i. Lug connections for field wiring.
- j. Factory mounted, wired, and run tested with factory-supplied motor.
- k. UL listed.

2. Combination Starter/Disconnect:

- a. Non-fused UL 508 disconnect switch with lockable handle (locks not provided).
- b. Cover interlock.
- c. Adjustable motor overload with trip indication.
- d. Manual overload reset button (accessible without opening enclosure).
- e. 115-v fused secondary control transformer (fuse included — fused primary and secondary over 50 amps).
- f. Hand/Off/Auto selector switch (accessible without opening enclosure).
- g. Separate 4-position terminal strip for remote H-O-A wiring.
- h. C series contactors.
- i. Horsepower rated for motor applications.
- j. NEMA 4 or higher enclosures.
- k. Lug connections for field power wiring.
- l. Factory mounted, wired, and run tested with factory-supplied motor.

F. External Bypass for Variable Frequency Drives:

Factory-supplied bypasses shall be covered under a 1 year limited warranty from the manufacturer from the date of shipment.

1. 200-230 v/3 Ph/60 Hz (1 to 7.5 Hp), 460-575 v/3 Ph/60 Hz (1 to 20 Hp), 380 v/3 Ph/50 Hz (1 to 15 Hp):
 - a. 4-position panel-mounted disconnect style switch with lockable handle (locks not provided), meets OSHA 1910.
 - b. Switch position indication (LINE/OFF/DRIVE/TEST).
 - c. Adjustable motor overload with trip indication (LINE position).
 - d. Manual overload reset button.
 - e. Horsepower rated for motor applications.
 - f. Direct control (no contactors, relays, or holding coils).
 - g. Complete isolation of inverter in LINE position.
 - h. NEMA 4 type metal enclosures.
 - i. Terminal strip provided for field power supply wiring.
 - j. Lug connection for field ground wire.
 - k. Gold flashed, auxiliary switch contact set (for switch position monitoring).
 - l. Factory mounted, wired to VFD and motor, and run tested (motor and VFD must be factory supplied and installed).
 - m. UL; UL, Canada; CE listed.
2. 200-230 v /3 Ph/60 Hz (10 to 75 Hp), 460-575 v/3 Ph/60 Hz (25 to 150 Hp), 380 v/3 Ph/50 Hz (20 to 75 Hp):
 - a. 4-position panel-mounted disconnect style switch with lockable handle (locks not provided), meets OSHA 1910.
 - b. Switch position indication (LINE/OFF/DRIVE/TEST).
 - c. Adjustable motor overload with trip indication (in LINE position).
 - d. Manual overload reset button.
 - e. Horsepower rated for motor applications.
 - f. 115-v control transformer with fused secondary (fused primary on units over 50 amps).
 - g. Contactor for Line Start/Stop.
 - h. Door-mounted Line Start and Line Stop pushbuttons.
 - i. Complete isolation of inverter in LINE position.
 - j. NEMA 12 type metal enclosures.
 - k. Terminal strip provided for field power supply wiring.
 - l. Lug connection for field ground wire.
 - m. Gold flashed, auxiliary switch contact set (for switch position monitoring).

- n. Factory mounted, wired to VFD and motor, and run tested (motor and VFD must be factory supplied and installed).
 - o. UL; UL, Canada; CE listed.
- G. Variable Frequency Drives:
1. Referenced Standards and Guidelines:
 - a. Institute of Electrical and Electronic Engineers (IEEE)
 - 1) IEEE 519-2014, IEEE Recommended Practice and Requirements for Harmonic Control in Electric Power Systems
 - b. Underwriters Laboratories (as appropriate)
 - 1) UL 508A
 - 2) UL 61800-5-1
 - c. National Electric Code (NEC)
 - 1) NEC 430.120, Adjustable-Speed Drive Systems
 - d. CSA Group
 - 1) CSA C22.2 No. 274
 - e. International Building Code (IBC)
 - 1) IBC 2018 Seismic - referencing ASCE 7-16 and ICC AC-156
 2. Qualifications:
 - a. Drives shall be UL labeled as a complete assembly. The base VFD shall be UL listed for 100 kA SCCR when installed in accordance with the manufacturer's guidelines.
 - b. CE Mark - The base drive shall conform to the European Union Electromagnetic Compatibility directive, a requirement for CE marking. The base drive shall meet product standard EN 61800-3 for the First Environment restricted distribution (Category C2).
 - c. The base drive shall be seismically certified and labeled as such in accordance with the 2018 International Building Code (IBC):
 - d. Seismic importance factor of 1.5, and minimum 2.5 SDS rating is required.
 - e. Ratings shall be based upon actual shake test data as defined by ICC AC-156, via all three axis of motion.
 - f. Seismic certification of equipment and components shall be provided by HCAI (formerly OSHPD) preapproval.
 - g. The base drive shall be SEMI-F47 certified. The drive must tolerate voltage sags to 50% for up to 0.2 seconds, sags to 70% for up to 0.5 seconds, and sags to 80% for up to one second.
 - h. Factory-mounted variable frequency drives (VFDs) shall be wired to factory-supplied motors.
 - i. Factory-supplied VFDs are programmed and started up from the factory and qualify the VFD, through ABB, for a 36-month warranty from date of commissioning or 40 months from date of sale, whichever occurs first.
 - j. The VFD parameters are programmed into the controller and removable keypad. In the event that the VFD fails and needs replacement, the program can then be uploaded to the replacement VFD via the original keypad.
 3. The drive package as specified herein and defined on the drive schedule shall be enclosed in a UL Type enclosure (enclosures with only NEMA ratings are not acceptable), completely assembled and tested by the manufacturer to ISO9001 standards.
 4. The drive shall provide full rated output from a line of +10% to -15% of nominal voltage. The drive shall continue to operate without faulting from a line of +25% to -35% of nominal voltage.
 - a. Drives shall be capable of continuous full load operation under the following environmental operating conditions:
 - 1) Ambient temperature -15 to 40°C (5 to 104°F).
 - 2) Altitude 0 to 1000 m (0 to 3,300 ft) above sea level.
 - 3) Humidity 5 to 95%, non-condensing.
 5. All drives shall utilize the same Advanced Control Panel (keypad) user interface.
 - a. Plain English text
 - 1) The display shall be in complete English words for programming and fault diagnostics (alpha-numeric codes are not acceptable).
 - 2) Safety interlock and run permissive status shall be displayed using predetermined application specific nomenclature, such as: Damper end switch, smoke alarm, vibration trip, and overpressure.
 - 3) Safety interlock, run permissive, Supervisory, external fault status, drive name, drive fault contact info and override shall have the option of additional customized project specific terms, such as: AHU-1 End Switch, Office Smoke Alarm, CT-2 Vibration.
 - b. The control panel shall include at minimum the followings controls:
 - 1) Four navigation keys (Up, Down, Left, Right) and two soft keys to simplify operation and programming.
 - 2) Hand-Off-Auto selections and manual speed control without having to navigate to a parameter.

- 3) Fault Reset and Help keys. The Help key shall include assistance for programming and troubleshooting.
 - c. Multiple Home View screens shall be capable of displaying up to 21 points of information. Customizable modules shall include bar charts, graphs, meters, and data lists. Displays shall provide real time graphical trending of output power, frequency, and current within selectable intervals of 15/30/60 minutes and 24 hours.
 - d. The control panel shall display the following items on a single screen; output frequency, output current, reference signal, drive name, time, and operating mode (Hand vs Auto, Run vs Stop). Bi-color (red/green) status LED shall be included. Drive (equipment) name shall be customizable.
 - e. There shall be a built-in time clock in the control panel. The clock shall have a battery backup with 10 years minimum life span. Daylight savings time shall be selectable.
 - f. I/O Summary display with a single screen shall indicate and provide:
 - 1) The status/values of all analog inputs, analog outputs, digital inputs, and relay outputs. Drives that require access to internal or live components to measure these values, are not acceptable.
 - 2) The programmed function of all analog inputs, analog outputs, digital inputs, and relay outputs.
 - 3) The ability to force individual digital I/O high or low and individual analog I/O to desired value, for increased personal protection during drive commissioning and troubleshooting. Drives that require access to internal or live components to perform these functions, are not acceptable.
 - g. The drive shall automatically backup parameters to the control panel. In addition to the automatic backup, the drive shall allow two additional unique backup parameter sets to be stored. Backup files shall include a time and date stamp. In the event of a drive failure, the control panel of the original drive can be installed on the replacement drive, and parameters from that control panel can be downloaded into the replacement drive.
 - h. The control panel shall display local technical support contact information as part of drive fault status.
 - i. The control panel shall be removable, capable of remote mounting.
 - j. The control panel shall have the ability to store screen shots, which are downloadable via USB.
 - k. The drive shall generate a QR code, which contains drive identification data, information on the latest events, and values of status and counter parameters.
 - l. The LCD screen shall be backlit with the ability to adjust the screen brightness and contrast, with inverted contrast mode. A user-selectable timer shall dim the display and save power when not in use.
 - m. The control panel shall include assistants specifically designed to facilitate start-up. Assistants shall include: First Start Assistant, Basic Operation, Basic Control, and PID Assistant.
 - n. Primary settings for HVAC shall provide quick set-up without the use of alpha-numerical parameters, for commissioning the drive and customer interfaces to reduce programming time.
 - o. The drive shall be able to operate with the control panel removed.
 - p. The drive shall be able to support a Bluetooth Advanced Control Panel. The Bluetooth control panel shall be FCC and QDL (Qualified Design Listing) certified.
 - 1) A free app (iOS and Android) shall replicate the control panel on a mobile device or tablet. The control panel's programming and control functionality shall function on the device. Customizing text, such as AHU-1 End Switch, shall be supported by the device's keyboard.
 - 2) Bluetooth connectivity shall allow uploading, downloading, and emailing of parameter sets.
 - 3) Bluetooth connectivity shall include two pairing modes: Always discoverable with a fixed passcode, and manual discovery with a unique generated passcode every pairing.
 - 4) Bluetooth connectivity shall be capable of being switched
6. All drives shall have the following hardware features/characteristics as standard:
 - a. Two (2) programmable analog inputs shall accept current or voltage signals. Current or Voltage selection configured via control panel. Drives that require access to internal components to perform these functions, are not acceptable.
 - b. Two (2) programmable analog outputs. At least one of the analog outputs shall be adjustable for current or voltage signal, configured via control panel. Drives that require access to internal components to perform these functions, are not acceptable.

- c. Six (6) programmable digital inputs. All digital inputs shall be programmable to support both active high and active low logic, and shall include adjustable on/off time delays. The digital input shall be capable of accepting both 24 VDC and 24 VAC.
 - d. Three (3) programmable Form-C relay outputs. The relay outputs shall include programmable on/off time delays. The relays shall be rated for a continuous current rating of 2 Amps. Maximum switching voltage of 250 VAC / 30 VDC. Open collector and Form-A relays are not acceptable. Drives that have less than (3) Form-C relay outputs shall provide an option card to provide additional relay outputs.
 - e. Drive terminal blocks shall be color coded for easy identification of function.
 - f. The drive shall include an isolated USB port for interface between the drive and a laptop. A non-isolated USB port is not acceptable.
 - g. An auxiliary power supply rated at 24 VDC, 250 mA shall be included.
 - h. At a minimum, the drives shall have internal impedance equivalent to 5% to reduce the harmonics to the power line. 5% impedance may be from dual (positive and negative DC link) chokes, or AC line reactor. Drives with only one DC link choke shall add an AC line choke integral to the drive enclosure. Reference the drive schedule to determine if additional harmonic mitigation is required for the system to comply with IEEE 519-2014.
 - i. The drive shall have cooling fans that are designed for field replacement. The primary cooling fan shall operate only when required and be variable speed for increased longevity and lower noise levels. Drives whose primary cooling fans are not variable speed, shall include a spare cooling fan.
 - j. The overload rating of the drive shall be 110% of its normal duty current rating for 1 minute every 10 minutes, 135% overload for 2 seconds every minute. The minimum current rating shall meet or exceed the values in the NEC/UL table 430.250 for 4-pole motors.
 - k. The input current rating of the drive shall not be greater than the output current rating. Per NFPA 70 430.122, drives with higher input current ratings may require the upstream wiring, protection devices, and source transformers to be upsized.
 - l. Circuit boards shall be coated per IEC 60721-3-3; Chemical gases Class 3C2 and Solid particles Class 3S2.
 - m. Earth (ground) fault detection shall function in both modulating (running) and non-modulating modes.
 - n. Coordinated AC transient surge protection system consisting of 4 MOVs (phase-to-phase and phase-to-ground), a capacitor clamp, and internal chokes. The MOVs shall comply with UL 1449 4th Edition. Drives that do not include coordinated AC transient surge protection shall include an external TVSS/SPD (Transient Voltage Surge Suppressor/Surge Protection Device).
 - o. The drive shall include a robust DC bus to provide short term power-loss ride through. The DC bus Joule to drive kVA ratio shall be 4.5 J/kVA or higher. An inertia-based ride through function should help maintain the DC bus voltage during power loss events. Drives with control power ride through only, are not acceptable.
7. All drives shall have the following software features as standard:
- a. A Fault Logger that stores the last 16 faults in non-volatile memory.
 - 1) The most recent 5 faults save at least 9 data points, including but not limited to: Time/date, frequency, DC bus voltage, motor current, DI status, temperature, and status words.
 - 2) The date and time of each fault and fault reset attempt shall be stored in the Fault Logger.
 - b. An Event Logger that stores the last 16 warnings or events that occurred, in non-volatile memory.
 - 1) Events shall include, but not limited to: Warning messages, checksum mismatch, run permissive open, start interlock open, automatic reset of a fault, power applied, auto start command, auto stop command, modulating started, and modulating stopped.
 - 2) The date and time of each event's start and completion points shall be stored in the Event Logger.
 - 3) The drive shall also provide the user the ability to configure what events to log for application specific requirements.
 - c. Programmable start method. Start method shall be selectable based on the application and function even if the motor was free-wheeling in the reverse direction: Flying-start, Normal-start, and Brake-on-start.
 - d. Programmable loss-of-load (broken belt/coupling) indication. Indication shall be selectable as a control panel warning, relay output, or over network communications. This function to include a programmable time delay to eliminate false loss-of-load indications.

- e. The following three-phase AC motor technologies shall be compatible:
 - 1) Asynchronous induction motors
 - 2) Permanent magnet synchronous (non-salient pole) motor
 - 3) Synchronous reluctance motor (SynRM)
 - 4) Permanent magnet assisted synchronous reluctance motor (PMSynRM)
- f. Motor heating function to prevent condensation build up in the motor. Motor heating adjustment, via parameter, shall be in “Watts.” Heating functions based only on “percent current” are not acceptable.
- g. Motor disconnect detection function enables the drive to detect when an output disconnect is opened, disable the drive output, and provide an indication message. Drives without this functionality shall have a disconnect switch auxiliary contact wired through dedicated conduit back to the drive enable control circuit.
- h. Motor phase order shall be changeable through software interface.
- i. Advanced power metering abilities shall be included in the drive and must be available over network communications. Drives without these data points, must include a separate power meter with each drive.
 - 1) Instantaneous output power (kW)
 - 2) Total power, broken down by kWh, MWh, and GWh units of measurement. Power meters that only display kWh and roll over or “max out” once the maximum kWh value is reached, are not acceptable. There shall be resettable and non-resettable total power meters within the drive.
 - 3) Time based kWh metering for: current hour, previous hour, current day, and previous day.
 - 4) Energy saving calculation shall be included that shows the energy and dollars saved by the drive.
- j. The drive shall include a motor flux optimization circuit that will automatically reduce applied motor voltage to the motor to optimize energy consumption and reduce audible motor noise.
- k. DC bus voltage ripple function shall provide a DC voltage reference for troubleshooting AC line issues or bus capacitor health.
- l. Run permissive circuit - There shall be a run permissive circuit for damper or valve control. The drive shall provide a relay output to the damper actuator, monitor end-switch status, and start running the motor based on application requirements. Damper control shall include the following configurable features fully functional in both Hand and Auto modes:
 - 1) A timeout function that identifies and annunciates a specific warning message when a damper has not opened or closed within the allotted time.
 - 2) Ability to interface with both damper open and damper closed end-switches on a single damper actuator.
 - 3) Sequence control that runs the fan initially at a fixed speed before commanding a discharge air damper to open. Required for all applications feeding a common plenum/space to prevent the fan from freewheeling backwards while damper strokes open.
 - 4) Multiple damper sequence control to support units with discharge air and outside air dampers. The drive shall command and verify the outside air damper is open before ramping the fan to a fixed speed, and then commanding the outside air damper open.
 - 5) Time based damper control for when an end-switch is not provided. For units with outside air and discharge air dampers, both dampers should have independent time based control capability.
- m. Start interlock circuit - Four separate start interlock (safety) inputs shall be provided. When any safety is opened, the motor shall be commanded to stop. The control panel will display the specific safety(s) that are open. The status of each safety shall be transmitted over the network communications. Wiring multiple safeties in series is not acceptable.
- n. External fault circuit - Three separate external fault inputs shall be provided. This circuit shall have the same features and functionality as the start interlock circuit, except it shall require a manual reset before the drive is allowed to operate the motor.

- o. The drive shall provide automatic protections to allow uninterrupted operations at a reduced speed or switching frequency.
 - 1) Switching frequency control circuit, that reduces the switching frequency based on actual drive temperature and allows higher switching frequency settings without derating the drive. It shall be possible to set a minimum and a target switching frequency.
 - 2) The drive shall include a temperature limit that when exceeded will reduce the drive output current.
 - 3) Input phase loss protection shall be provided, whereas the output current is automatically derated by 50% if an input phase loss is detected by the drive.
- p. Visual function block adaptive programming allowing custom control schemes, minimizing the need for external controllers, i.e., cooling tower staging logic. A free software tool shall be used to configure adaptive programming.
- q. The ability to automatically restart after an over-current, over-voltage, under-voltage, external fault, or loss of input signal protective trip. The number of restart attempts, trial time, and time between attempts shall be programmable. Each of these faults may have automatic restart individually disabled via a parameter selection.
- r. Three (3) programmable critical frequency lockout ranges to prevent the drive from operating the load continuously at an unstable speed/load.
- s. The drive shall have three methods to control constant frequency/speed references:
 - 1) Seven (7) programmable preset frequencies/speeds using (3) inputs.
 - 2) Six (6) different programmable preset frequencies/speed tied to 6 independent control inputs and requires an additional start command.
 - 3) Six (6) different programmable preset frequencies/speed tied to 6 independent control inputs and does not require any additional start command input.
- t. Two independently adjustable accel and decel ramps sets with 1 - 1800 seconds adjustable time ramps.
- u. PID functionality shall be included in the drive.
 - 1) Programmable “Sleep” and “Wake up” functions to allow the drive to be started and stopped based on the level of a process feedback signal.
 - 2) The drive shall include an independent PID loop for customer use, assigned to an Analog Output. This PID loop may be used for cooling tower bypass valve control, chilled water valve, etc.
- v. At least 4 parameter user sets that can be saved to the permanent memory and recalled using a digital input, timed function, or supervision function.
- w. Drive shall be compatible with an accessory that allows the control board to be powered from an external 24 VDC/VAC source, allowing the drive control to remain powered by a UPS during an extended power outage.
- x. A computer-based software tool shall be available to allow a laptop to program the drive. The drive shall be able to support programming without the need for line voltage. All necessary power shall be sourced via the laptop USB port.
- y. The drive shall include a fireman’s override mode. Upon receipt of a contact closure from the Fire Alarm Life Safety system, the drive shall operate in a dedicated Override mode distinct and separate from the drive’s Normal operation mode. The following features will be available in the drive override function:
 - 1) The Override mode shall be secured by passcode to prevent changes once programmed.
 - 2) The drive shall ignore external inputs and commands not defined as part of the override function.
 - 3) Override operation mode shall be selectable between: single frequency, multiple fixed frequencies, follow an analog input signal, PID control, or come to a forced stop.
 - 4) High priority safeties shall stop the drive and lower priority safeties shall be ignored in Override mode.
 - 5) Drive faults shall be defined in Critical and Low priority groups. Critical faults shall stop the drive. Low priority faults shall be reset. Reset trials and timing shall be programmable.
 - 6) The drive shall be configurable to receive from 1 to 3 discrete digital input signals and operate at up to three discrete speeds.

8. Security Features

- a. The drive manufacture shall clearly define cybersecurity capabilities for their products.
- b. The drive shall include passcode protection against parameter changes.
 - 1) There shall be multiple levels of passcode protection including: End User, Service, Advanced, and Override.
 - 2) The drive shall support a customer generated unique passcode between 0 and 99,999,999.
 - 3) The drive shall log an event whenever the drive passcode has been entered.
 - 4) The drive shall provide a security selection that prevents any “back door” entry. This selection even prevents the drive manufacturer from being able to bypass the security of that drive.
 - 5) A security level shall be available that prevents the drive from being flashed with new firmware.
- c. A checksum feature shall be used to notify the owner of unauthorized parameter changes made to the drive. The checksum feature includes two unique values assigned to a specific programming configuration.
 - 1) One checksum value shall represent all user editable parameters in the drive except communication setup parameters. A second checksum value shall represent all user editable parameters except communication setup, energy, and motor data parameters.
 - 2) Once the drive has been commissioned the two values can be independently saved in the drive.
 - 3) The drive shall be configurable to either: Log an Event, provide a Warning, or Fault upon a parameter change when the current checksum value does not equal the saved checksum value.
- d. The “Hand” and “Off” control panel buttons shall have the option to do the following:
 - 1) Be individually disabled (via parameter) for drives mounted in public areas to prevent unauthorized changes.
 - 2) Require a second button press of “Hand” or “Off” within 5 seconds of the original selection to confirm the change and prevent accidental transition out of “Auto” mode.

9. Network Communications

- a. The drive shall have an EIA-485 port with removable terminal blocks. The onboard protocols shall be BACnet MS/TP, Modbus, and Johnson Controls N2. Optional communication cards for BACnet/IP, LonWorks, Profibus, Profinet, EtherNet/IP, Modbus TCP, and DeviceNet shall be available. The use of third party gateways are not acceptable.
- b. The drive shall have independent end of line (EOL) termination and biasing switches for EIA-485 networks.
- c. The drive shall contain EIA-485 network self-diagnostics to assist in troubleshooting issues such as incorrect polarity, incorrect baud rate, noise on the wire or addressing errors.
- d. The drive shall have the ability to communicate via two protocols at the same time, one onboard protocol and one option card based protocol. Once installed, the drive shall automatically recognize any optional communication cards without the need for additional programming.
- e. The drive shall not require a power cycle after communication parameters have been updated.
- f. The embedded BACnet connection shall be a MS/TP interface. The drive shall be BTL Listed to Revision 14 or later. Use of non-BTL Listed drives are not acceptable.
- g. The drive shall be classified as an Applications Specific Controller (B-ASC). The interface shall support all BIBBs defined by the BACnet standard profile for a B-ASC including, but not limited to:
 - 1) Data Sharing: Read Property Multiple-B, Write Property Multiple-B, COV-B
 - 2) Device Management: Time Synchronization-B
 - 3) Object Type Support: MSV, Loop
- h. The drive’s relay output status, digital input status, analog input/output values, Hand-Auto status, warning and fault information shall be capable of being monitored over the network. The drive’s start/stop command, speed reference command, relay outputs and analog outputs shall be capable of being controlled over the network. Remote drive fault reset shall be possible.

10. Disconnect (optional) - A circuit breaker or disconnect switch shall be provided when indicated on the drive schedule. The disconnect shall be door interlocked and padlockable. Drive input fusing shall be included on all packaged units that include a disconnecting means. All disconnect configurations shall be UL Listed by the drive manufacturer as a complete assembly and carry a UL508A label. Disconnect packages manufactured by anyone other than the drive manufacturer, are not acceptable.
 11. Eclipse Bypass (optional) - Bypass drive packages shall be provided when indicated on the drive schedule. All drive/bypass configurations shall be UL Listed by the drive manufacturer as a complete assembly and carry a UL508A label. Bypasses manufactured by anyone other than the drive manufacturer, are not acceptable.
 - a. The drive and bypass package shall be a complete factory wired and tested bypass system consisting of a padlockable disconnect device, drive output contactor, bypass contactor, and drive input fuses.
 - b. The drive and bypass package shall have a UL listed short circuit current rating of 100 kA, for 240 VAC and 480 VAC systems, and this rating shall be indicated on the rating label.
 - c. The bypass control shall be powered by a three-phase switch mode power supply with a voltage tolerance of +30%, -35%. Single-phase power supplies and control power transformers (CPT) are not acceptable.
 - d. The drive and bypass package shall be seismic certified and labeled to the IBC. Seismic importance factor of 1.5 rating is required and shall be based upon actual shake table test data as defined by ICC AC-156. Seismic certification of equipment and components shall be provided by HCAI (formerly OSHPD) preapproval.
 - e. All bypass packages shall utilize a dedicated LCD bypass control panel (keypad) user interface. The bypass control panel must be a separate display from the drive control panel. Bypass packages that use a single shared drive/bypass control panel are not acceptable, due to that control panel acting as a single point of failure.
 - 1) The bypass shall include a two-line, 20-character LCD display. The display shall allow the user to access parameters and view:
 - a) All three phases of the bypass input voltage, current (Amps) and power (kW)
 - b) Bypass faults, warnings, and fault logs
 - c) Bypass operating time and energy consumption (resettable)
- 2) The bypass control panel shall include the following controls:
 - a) Four navigation keys (Up, Down, Enter, Escape)
 - b) Bypass Hand-Off-Auto, Drive mode/Bypass mode selectors, Bypass fault reset
 - 3) The following indicating lights (LED PTT type) or control panel display indications shall be provided.
 - a) Drive mode selected, Bypass mode selected
 - b) Drive running, Bypass running
 - c) Drive fault, Bypass fault
 - 4) Safety interlock and run permissive status shall be displayed using predetermined application specific nomenclature, such as: Damper end switch, smoke alarm, vibration trip, and overpressure.
- f. All bypasses shall have the following hardware features/characteristics as standard:
 - 1) Six (6) digital inputs and five (5) Form-C relay outputs. The digital inputs shall be capable of accepting both 24 VDC and 24 VAC. The bypass control board shall include an auxiliary power supply rated 24 VDC, 250 mA.
 - 2) Drive isolation fuses shall be provided. Bypass designs which have no such fuses, or that only incorporate fuses common to both the drive and the bypass are not acceptable. Third contactor "isolation contactors" and service switches are not an acceptable alternative to drive isolation fuses.
 - 3) The bypass shall be able to detect a single-phase input power condition before the bypass contactor closes or while running the motor in bypass, by monitoring all three phases of input voltage. Relying on a high current trip if the motor is single-phased is not acceptable.
 - 4) The bypass shall be designed for stand-alone operation and be completely functional in both Hand and Automatic modes, even if the drive and/or drive's control board has failed. Network communications shall remain functional. Bypass systems that do not maintain full functionality in the event of a drive failure, are not acceptable.

- g. All bypasses shall have the following software features as standard:
 - 1) Programmable loss-of-load (broken belt/coupling) indication shall be functional in drive and bypass mode.
 - 2) The bypass shall also support run permissive and start interlock control functionality, including start delay, as previously specified in the drive section.
 - 3) The bypass control shall monitor the status of the drive and bypass contactors and indicate when there is a welded contactor contact or open contactor coil.
 - 4) The bypass shall include a selection for either manual or automatic transfer to bypass. The automatic transfer mode shall allow the user to select the specific drive fault types that result in an automatic transfer to bypass. The automatic transfer mode shall not allow a transfer to bypass on motor related faults. Automatic transfer schemes that do not differentiate between fault types, are not acceptable.
 - 5) The bypass shall include the ability to select the operating mode of the system (Drive/Bypass) from either the bypass control panel or digital input.
 - 6) The bypass shall include the ability to know the phase sequence and provide a phase sequence fault to indicate if the bypass and drive would run the motor in the opposite direction, this feature shall be enabled by default.
 - 7) The bypass shall include a supervisory control mode that monitors the value of the drive's analog input (feedback). This feedback value is used to control the bypass contactor on/off state. The supervisory mode shall allow the user to maintain hysteresis control over applications such as cooling towers and booster pumps.
 - 8) Selectable Class 10, 20, or 30 electronic motor overload protection shall be included in both drive and bypass mode.
- 9) The drive and bypass shall be designed to operate as an integrated system when in Override mode. Whether operating in drive or bypass mode, the low priority safeties will be ignored, and high priority safeties will be followed. External start/stop commands will be ignored. There shall be four selectable Override modes:
 - a) Bypass only, with two smoke control modes:
 - i) Fixed pre-configuration of digital inputs
 - ii) Configurable high/low priority safeties and faults, to allow configuration to meet needs of local Authority Having Jurisdiction.
 - b) Drive only
 - c) Drive then transfer to bypass, in the event of a drive fault
 - d) Force to Stop
- 10) Before the bypass circuit can be tested in commissioning, the drive must start the motor to check for shorts and ground faults.
- h. Network communications - the bypass shall include BACnet MS/TP, Modbus, and Johnson Controls N2 as standard. The bypass BACnet implementation shall be BTL Listed to Revision 14 or later. Optional communication cards for BACnet/IP, LonWorks, Profibus, Profinet, Ethernet/IP, Modbus TCP, and DeviceNet shall be available.
 - 1) The bypass relay output status, digital input status, warning and fault information can be monitored over the network. Status information shall be monitored, including; operating mode (drive vs bypass), current drawn in bypass mode, broken belt, and phase-to-phase voltage. The bypass start/stop command, force to bypass command, and relay outputs shall be capable of being controlled over the network.

