



Controls Operation and Troubleshooting

CONTENTS

	Page
SAFETY CONSIDERATIONS	1
GENERAL	2
Abbreviations Used in This Manual	2
HARDWARE	2
Main Control Board	2
ISM (Integrated Starter Module) — Option	2
IOB (Input/Output Board)	4
• IOB CONFIGURATION	
• IOB COMPONENTS AND WIRING	
Communication Cables	4
• IOB LAYOUT	
Sensors	21
• PRESSURE TRANSDUCERS	
• TEMPERATURE SENSORS	
Controls Outputs	21
• EVAPORATOR/CONDENSER WATER PUMP	
• INLET GUIDE VANE	
• ECONOMIZER DAMPER VALVE	
• ENVELOP CONTROL/HGBP VALVE	
• ECONOMIZER BYPASS VALVE	
• VFD	
PIC 6 USER INTERFACE	21
Web Connection	21
General Interface Features	22
• ICONS	
• SCREENS	
PIC 6 CONTROL OPERATION	26
Start-Stop Control	26
• LOCAL	
• LOCAL SCHEDULE	
• REMOTE	
• NETWORK	
Compressor Run Status	26
Chiller Start-Up Sequence	26
• PRE-START CHECK	
• START-UP	
Chiller Shutdown Sequence	27
Oil Lubrication Control	27
Control Points	28
• SET POINT	
• CONTROL POINT TEMPERATURE	
• TEMPERATURE RESET	
• CAPACITY CONTROL	
• RAMP LOADING	
• SURGE CORRECTION CONTROL	
• ENVELOP/HOT GAS BYPASS (HGBP) CONTROL	
• ECONOMIZER DAMPER VALVE CONTROL	
• DEMAND LIMIT	
• OVERRIDE CONTROL	
• RECYCLE CONTROL	
• RUNNING TIMERS AND COUNTERS	
• WATER PUMPS CONTROL (FREEZE PREVENTION)	
• CONTROL TEST	
• AUTO RESTART	
• SWIFT RESTART (CAPACITY RECOVERY™)	
• COOLING TOWER CONTROL	
• HEAD PRESSURE CONTROL	
• ICE BUILD OPTION	
• TIME SCHEDULE	
• BLACK BOX	
• PRESSURE TRANSDUCER CALIBRATION	
• TEMPERATURE SENSOR CALIBRATION	
• ISM VFD INPUT/OUTPUT CALIBRATION	
• ALARM EMAIL	
• PROGNOSTICS	
• MASTER SLAVE CONTROL	
Oil EXV Option	37
Pumpdown/Lockout	37
Displaying Data Trends	37
Hydraulic Option	38
• WATER FLOW MEASUREMENT	
• WATER PRESSURE DIFFERENCE MEASUREMENT	
DIAGNOSTICS AND TROUBLESHOOTING	38
Displaying Alarms	38
Resetting Alarms	38
Alarm/Alert Codes	38
Event States	55
SETTINGS FOR THE CONTROLLER	55
Unit IP Address	55
• TOUCH SCREEN CALIBRATION	
Touch Screen Configuration Language and Units ..	56
COMMUNICATION PROBLEMS	56
Hardware Problems	56
Web Interface Problems	56
Ethernet/IP Connection Problems	56
• UNIT IS POINT-TO-POINT CONNECTED TO A PC	
• UNIT IS CONNECTED TO THE LOCAL NETWORK	
• ETHERNET CONNECTION ON THE PC	
• JAVA APPLICATION CONFIGURATION	
APPENDIX A — PIC 6 SCREEN AND TABLE	
STRUCTURE	59
APPENDIX B — DIP SWITCH SETTINGS	97
APPENDIX C — IOB STATUS INDICATORS	98
APPENDIX D — CONFIGURING BMS PROTOCOL ..	99

SAFETY CONSIDERATIONS

Installing, starting up, and servicing this equipment can be hazardous due to system pressures, electrical components, and equipment location (roof, elevated structures, etc.). Only trained, qualified installers and service mechanics should install, start up, and service this equipment. When working on this equipment, observe precautions in the literature, and on tags, stickers, and labels attached to the equipment, and any other safety precautions that apply. Follow all safety codes. Wear safety glasses and work gloves. Use care in handling, rigging, and setting this equipment, and in handling all electrical components.

⚠ WARNING

Electrical shock can cause personal injury and death. Shut off all power to this equipment during installation. Use lock out/tag out procedures and be aware that there may be more than one disconnect switch. Be sure to tag all disconnect locations to alert others not to restore power until work is completed. Even when the main circuit breaker or isolator is switched off, certain circuits may still be energized, since they may be connected to a separate power source.

⚠ WARNING

Electrical currents cause components to get hot either temporarily or permanently and may cause burns. Handle power cable, electrical cables and conduits, terminal box covers, and motor frames with great care.

⚠ CAUTION

This unit uses a microprocessor control system. Do not short or jumper between terminations on circuit boards or modules; control or board failure may result.

Be aware of electrostatic discharge (static electricity) when handling or making contact with circuit boards or module connections. Always touch a chassis (grounded) part to dissipate body electrostatic charge before working inside control center.

Use extreme care when handling tools near boards and when connecting or disconnecting terminal plugs. Circuit boards can easily be damaged. Always hold boards by the edges and avoid touching components and connections.

This equipment uses, and can radiate, radio frequency energy. If not installed and used in accordance with the instruction manual, it may cause interference to radio communications. The PIC 6 control boards have been tested and found to comply with the limits for a Class A computing device pursuant to International Standard in North America EN 61000-2/3 which are designed to provide reasonable protection against such interference when operated in a commercial environment. Operation of this equipment in a residential area is likely to cause interference, in which case the user, at his own expense, will be required to take whatever measures may be required to correct the interference.

Always store and transport replacement or defective boards in anti-static shipping bag.

GENERAL

This publication contains operation and troubleshooting information for PIC (Product Integrated Control) 6, a system for controlling 19XR semi-hermetic centrifugal liquid chillers. This publication is based on 19XR PIC 6 Version 2.3 software (SCG-SR-20S200230).

The PIC 6 control system monitors and controls all operations of the chiller. The microprocessor control system matches the capacity of the chiller to the cooling load while providing state-of-the-art chiller protection. The system controls cooling load within the set point plus or minus the dead band by sensing the water or brine temperature and regulating the inlet guide vane via a mechanically linked actuator motor, and regulating VFD (variable frequency drive) speed if the compressor is powered by a variable speed drive. The guide vane is a variable flow pre-whirl assembly that controls the refrigeration effect in the cooler by regulating the amount of refrigerant vapor flow into

the compressor. An increase in guide vane opening increases capacity. A decrease in guide vane opening decreases capacity. The microprocessor-based control center protects the chiller by monitoring the digital and analog inputs and executing capacity overrides or safety shutdowns as necessary.

The PIC 6 control system also provides access to a Control Test function covering all outputs except compressor relay outputs.

Abbreviations Used in This Manual

The following abbreviations are used in this manual:

CCM	— Chiller Control Module
CCN	— Carrier Comfort Network
CCN mode	— Operating Mode: CCN
EC	— Envelop Control (Hot Gas Bypass)
ECDW	— Entering Condenser Water
ECW	— Entering Chilled Water
EXV	— Electronic Expansion Valve
HMI	— Human Machine Interface
I/O	— Input/Output
IOB	— Input/Output Board
ISM	— Integrated Starter Module
LCDW	— Leaving Condenser Water
LCW	— Leaving Chilled Water
LED	— Light-Emitting Diode
LEN	— Local Equipment Network (internal communication linking the main board to slave boards)
MCB	— Main Control Board
PIC	— Product Integrated Control
RLA	— Rated Load Amps
SRD	— Split Ring Diffuser
TFT	— Thin Film Transistor
VFD	— Variable Frequency Drive
UI	— User Interface

HARDWARE

The PIC 6 control system consists of one main control board and up to four IOBs (input/output board modules). All boards communicate via an internal LEN bus. PIC 6 is compatible with unit-mounted VFD/starter options that do not utilize an ISM (integrated starter module). For this application LEN is converted to Modbus protocol for starter communication. Depending upon option the conversion is either native to PIC 6 or an converter module is used.

Main Control Board

The main control board is supplied from a 24 VAC supply reference to earth ground. In the event of a power supply interrupt, the unit restarts automatically without the need for an external command. However, any faults active when the supply is interrupted are saved, and may in certain cases prevent a circuit or unit from restarting. Figure 1 shows the main controller interface and connectors.

⚠ CAUTION

Maintain the correct polarity when connecting the power supply to the boards. Otherwise, the boards may be damaged.

ISM (Integrated Starter Module) — Option

The ISM is the motor control module, used for starters/VFDs which do not have direct communication via Modbus. If equipped the ISM is located in the starter enclosure and is the interface between the starter and the PIC 6 controls; its function is to provide motor protection and starter control. The ISM is powered by single phase 115 VAC, 50 Hz or 60 Hz source. Table 1 lists ISM inputs and outputs. Figure 2 shows the ISM physical layout.

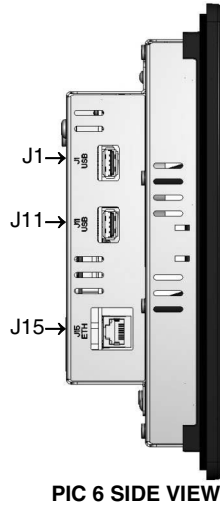

PIC 6 SIDE VIEW

- J1: USB
- J5: USB Connector
- J6: LEN Connector
- J7: CCN Connector
- J8: BACnet MS/TP or Modbus RTU, J8 – (PHOENIX 1757035 – not factory supplied)
- J9: RNET
- J10: RS485, Modbus/RTU Comm to VFD Starter
- J11: USB
- J14: Power Supply Connector (24 VAC)
- J15: Ethernet Connector (Port 0, default IP 169.254.0.1, mask 255.255.0.0). BACnet/IP or Modbus TCP/IP.
- J16: Ethernet Connector (Port 1, default IP: 192.168.100.100, mask 255.255.255.0)

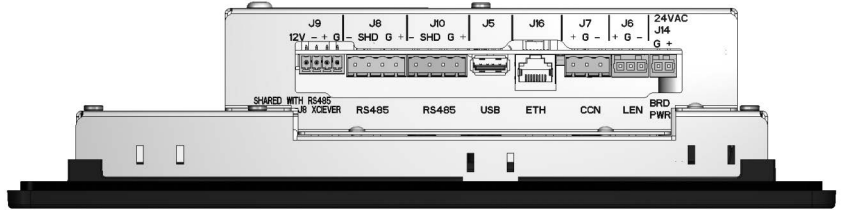

PIC 6 BOTTOM VIEW

NOTES:

1. Either BACnet/MSTP or BACnet/IP can be enabled and either Modbus/RTU or Modbus/TCP/IP can be enabled. Controller does not allow both to be enabled at the same time.
2. Modbus RTU can be configured simultaneously with BACnet IP.
3. BACnet MS/TP can be configured simultaneously with Modbus TCP/IP.

Fig. 1 — PIC 6 Connectors

Table 1 — ISM Input/Output Descriptions

DESCRIPTION	POINT NAME	TYPE	PIN NUMBER	INPUT/OUTPUT
Communication	COMM	Dry contact	J7-A,B,C	Input/Output
Compressor Run Contact	RUN_AUX	Dry contact	J2-11,12	Input
Compressor Start Contact	STAR_AUX	Dry contact	J2-9,10	Input
Compressor Start Relay	COMP_SR	Relay	J9-1,2	Output
Compressor Transition Relay	TRANS	Relay	J9-3,4	Output
Ground Fault Phase 1	GRFLT_31	0 to 5 V	J5-1,2	Input
Ground Fault Phase 2	GRFLT_23	0 to 5 V	J5-3,4	Input
Ground Fault Phase 3	GRFLT_12	0 to 5 V	J5-5,6	Input
Line Current C1	LN_AMPS1	0 to 5 A (RMS)	J4-1,2	Input
Line Current C2	LN_AMPS2	0 to 5 A (RMS)	J4-3,4	Input
Line Current C3	LN_AMPS3	0 to 5 A (RMS)	J4-5,6	Input
Line Voltage V1	LN_VOLT1	0 to 575 VAC	J3-1	Input
Line Voltage V2	LN_VOLT2	0 to 575 VAC	J3-2	Input
Line Voltage V3	LN_VOLT3	0 to 575 VAC	J3-3	Input
Shunt Trip Relay	TRIPR	Relay	J9-5,6	Output
Starter Fault	STARTFELT	Dry contact	J2-7,8	Input
VFD Speed Feedback	VFD_IN	0 to 5 V (default), or 0 to 10 V (selectable)	J6-1,2	Input
VFD Target Speed	VFD_OUT	0 to 20 mA	J8-1,2	Output

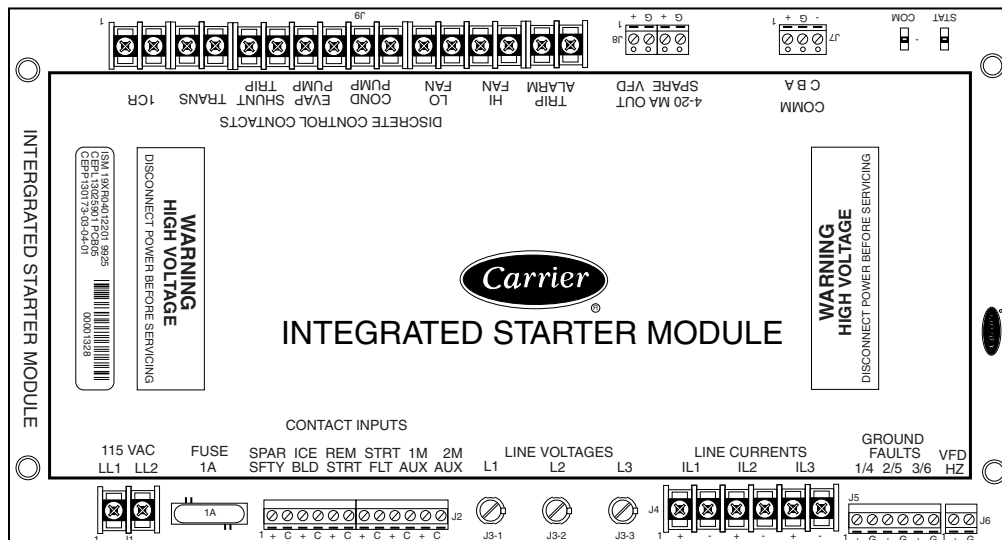

Fig. 2 — Integrated Starter Module (ISM)

IOB (Input/Output Board)

The IOB is supplied from a 24 VAC supply reference to earth ground.

IOB CONFIGURATION

The input/output boards can be configured for different types of input/output. If a an input or output type is supported for the specific channel then it can be modified in the Configuration Menu as shown in Table 2:

Table 2 — IOB Configuration

ANALOG INPUT		ANALOG OUTPUT	
0	Disable	0	Disable
1	0 to 5 VDC	1	4 to 20 mA
2	4 to 20 mA	2	0 to 10 VDC
3	10 kΩ (thermistor)		
4	5 kΩ (thermistor)		
5	Ohm (Shift_Dis)		
6	100 Ohm RTD		

IOB COMPONENTS AND WIRING

The components listed in Tables 3-10 are available at the user's terminal block on the IOB. Some are available only if the unit is operating in Remote mode. Figures 3-7 and 12-15 show IOB wiring diagrams. Figures 8-11 and 16-19 show additional control wiring.

Communication Cables

The communication transmission cables have the following electrical characteristics:

- 2 signal conductors and one ground conductor of 20 AWG or larger, 100% shielded
- One tinned copper braid (65% coverage)

Recommended cables are shown below:

USAGE	CABLE
Intra-Building	Belden 8772
High Temperature	Belden 85240
Plenum	Belden 89418

To avoid potential interference, route communication cables between the starter and the chiller control panels as far away as possible from high voltage cable and other likely disturbances. Always separate communication cables from other cables and always run wiring as directly as possible.

IOB LAYOUT

Dip switch SW1 controls the board address. If a board is replaced ensure same address is configured prior. Dip switch SW2 has to be set depending on AI input type. A channel has to be configured ON if signal in is 4-20 mA. See Fig. 3.

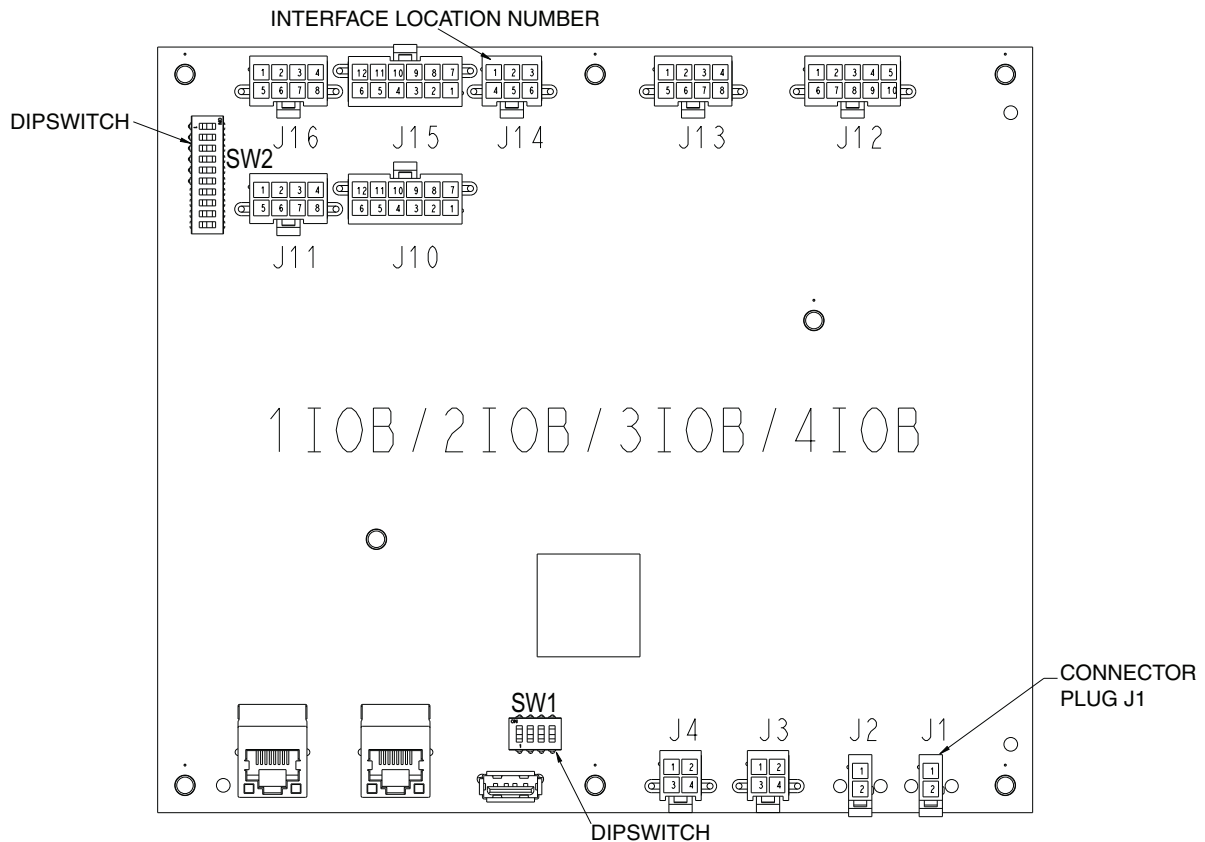

Fig. 3 — IOB Board

Table 3 — 19XR2-E IOB1 Connections

DESCRIPTION	CHANNEL	TERMINAL	TYPE	OPTIONAL
Entering Chilled Water Temperature	AI1	J16-1,5	5 kΩ	—
Leaving Chilled Water Temperature	AI2	J16-2,6	5 kΩ	—
Entering Condenser Water Temperature	AI3	J16-3,7	5 kΩ	—
Leaving Condenser Water Temperature	AI4	J16-4,8	5 kΩ	—
Evaporator Refrigerant Liquid Temperature	AI5	J15-6,12	5 kΩ	—
Discharge Gas Temperature	AI6	J15-5,11	5 kΩ	—
Condenser Pressure	AI7	J15-4	5 VDC	—
Evaporator Pressure	AI8	J15-3	5 VDC	—
FS VFD Load Current	AI10	J15-1,7	4 to 20 mA	Yes
Head Pressure Output 2	AO1	J14-1-4	4 to 20 mA	Yes
Oil EXV Output	AO2	J14-2, 5	4 to 20 mA	Yes
EC Valve Output mA	AO3	J14-3,6	4 to 20 mA	Yes
Chiller Lockout Input	DI1	J13-5 (1TB-3,4)	24 VAC	Yes, NO (dry contact)
Spare Safety	DI2	J13-6 (1TB-5,6)	24 VAC	Yes, NO (dry contact), normally open
Remote Contact Input	DI3	J13-7 (1TB-7,8)	24 VAC	Yes, NO (dry contact); closed indicates start chiller signal
Remote Emergency Stop Input	DI4	J13-8 (1TB-9,10)	24 VAC	Yes, NO (dry contact); closed indicates stop chiller signal
Stage 1 IGV Increase	DO1	J12-7	24 VAC	Yes
Stage 1 IGV Decrease	DO2	J12-10	24 VAC	Yes
Chiller Alarm Relay	DO3	J12-2	24 VAC	Yes
VFD Run/Stop Interlock	DO4	J12-5	24 VAC	Required for FC-102 drive

LEGEND

EXV — Electronic Expansion Valve
FS — Free Standing
IGV — Inlet Guide Vane
IOB — Input/Output Board
NO — Normally Open
VFD — Variable Frequency Drive

NOTES:

1. See Fig. 4 for IOB1 wiring diagram.
2. For pressure readings, only Vout (output) terminal is indicated. See Fig. 4 for Vin (+) and ground (-).
3. Defaults are shown. In some cases the IOB can be configured differently depending on job requirements.

Table 4 — 19XR2-E IOB2 Connections

DESCRIPTION	CHANNEL	TERMINAL	TYPE	OPTIONAL
Motor Winding Temperature 1	AI1	J16-1,5	5 kΩ	—
Thrust Bearing Oil Temperature	AI2	J16-2,6	5 kΩ	—
Oil Sump Temperature	AI3	J16-3,7	5 kΩ	—
Oil Supply Temperature	AI4	J16-4, 8	5 kΩ	Yes
Guide Vane Actual Position	AI5	J15-6,12	4 to 20 mA	Yes, standard for 19XRC
Oil Supply Pressure	AI6	J15-5	5 VDC	—
Oil Sump Pressure	AI7	J15-4	5 VDC	—
EC (HGBP) Valve Feedback	AI8	J15-3,9	4 to 20 mA	Yes, standard for 19XRC
Motor Winding Temperature 2	AI9	J15-2,8	5 kΩ	Yes
Motor Winding Temperature 3	AI10	J15-7	5 kΩ	—
Diffuser Pressure	AI11	J10-8	5 VDC	—
Guide Vane 1 Output	AO1	J14-1,4	4 to 20 mA	—
Diffuser Output (Option Enabled)	AO2	J14-2,5	4 to 20 mA	Yes
Liquid Bypass Valve (Option Enabled)	A02	J14-2-5	4 to 20 mA	Yes
Head Pressure Output	AO3	J14-3 (2TB-3.4)	4 to 20 mA	Yes, NO (dry contact)
Evap Water Flow Switch	DI1	J13-5 (2TB-5,6)	24 VAC	Yes, NO (dry contact)
Cond Water Flow Switch	DI2	J13-6 (2TB-7,8)	24 VAC	Yes, NO (dry contact)
High Pressure Switch	DI3	J13-7,3	24 VAC	—
Ice Build Contact	DI4	J13-8,4, (2TB-11,12)	24 VAC	Yes, NO (dry contact)
Oil Heater Relay	DO1	J12-7	24 VAC	—
Oil Pump Relay	DO2	J12-10	24 VAC	—
EC (HGBP) Solenoid Valve / Open	DO3	J12-2	24 VAC	Yes
Vapor Source SV (19XRC only)	DO4	J12-5	24 VAC	XRC Only

LEGEND

IOB — Input/Output Board
NO — Normally Open

NOTES:

1. See Fig. 5 for IOB2 wiring diagram.
2. For pressure readings, only Vout (output) terminal is indicated. See Fig. 5 for Vin (+) and ground (-).
3. Defaults are shown. In some cases the IOB can be configured differently depending on job requirements.

Table 5 — 19XR2-E IOB3 Connections

DESCRIPTION	CHANNEL	TERMINAL	TYPE	OPTIONAL
Heat Reclaim Entering Temp	AI3	J16-3,7	5 kΩ	—
Heat Reclaim Leaving Temp	AI4	J16-4,8	5 kΩ	—
Remote Reset Temperature	AI5	J15-6,12	5 kΩ	Yes
Auto Water Temp Reset	AI6	J15-5,11	4 to 20 mA	—
Common Chilled Water Supply (CHWS) Temperature	AI7	J15-4, 10	5 KOhm	Yes
Auto Demand Limit Input	AI8	J15-3,9	4 to 20 mA	Yes
Common Chilled Water Return (CHWR) Temperature	AI9	J15-2, 8	5 KOhm	Yes
Refrigerant Leak Sensor	AI10	J15-1,7	4 to 20 mA	Yes
Chiller Status Output mA ON = 20mA, OFF = 4 mA, TRIPOUT = 8 mA, Not OFF and Compressor not running = 12 mA	AO1	J14-1,4	4 to 20 mA	Yes
Fire Security Interlock	DI1	J13-5 (3TB-19,20)	24 VAC	Yes
Chiller Status	DO1	J12-7(3TB-27,28)	24 VAC	Yes
Chiller Alert Relay	DO2	J12-10 (3TB-29,30)	24 VAC	Yes, NO (dry contact)
Chilled Water Pump	DO3	J12-2 (3TB-31,32)	24 VAC	Yes, NO (dry contact)
Condenser Water Pump	DO4	J12-5 (3TB-33,34)	24 VAC	Yes, NO (dry contact)

LEGEND

CE — Compressor End
EC — Envelop Control
HGBP — Hot Gas Bypass
IOB — Input/Output Board
ME — Motor End
NO — Normally Open

NOTES:

1. See Fig. 6 for IOB3 wiring diagram.
2. For pressure readings, only Vout (output) terminal is indicated. See Fig. 6 for Vin (+) and ground (-).
3. Defaults are shown. In some cases the IOB can be configured differently depending on job requirements.

Table 6 — 19XR2-E IOB4 Connections

DESCRIPTION	CHANNEL	TERMINAL	TYPE	OPTIONAL
Entering Evaporator Water Pressure	AI3	J16-7 (4TB-1 (Vin),2 (Vout),3 (ground))	5 VDC	Yes
Leaving Evaporator Water Pressure	AI4	J16-8 (4TB-4 (Vin), 5(Vout), 6 (ground))	5 VDC	Yes
Entering Condenser Water Pressure	AI5	J15-6 (4TB-7 (Vin), 8(Vout), 9 (ground))	5 VDC	Yes
Leaving Condenser Water Pressure	AI6	J15-5, (4TB-10 (Vin), 11(Vout), 12 (ground))	5 VDC	Yes
Evaporator Water Flow Measurement	AI8	J15-3, 9, (4TB-13,14)	4 to 20 mA	Yes
Condenser Water Flow Measurement	AI9	J15-2, 8, 4TB-15,16	4 to 20 mA	Yes
Tower Fan High	DO3	J12-2(4TB-25,26)	24 VAC	Yes
Tower Fan Low	DO4	J12-5(4TB-27,28)	24 VAC	Yes

LEGEND

IOB — Input/Output Board
NO — Normally Open

NOTES:

1. See Fig. 7 for IOB4 wiring diagram.
2. For pressure readings, only Vout (output) terminal is indicated. See Fig. 7 for Vin (+) and ground (-).
3. Defaults are shown. In some cases the IOB can be configured differently depending on job requirements.

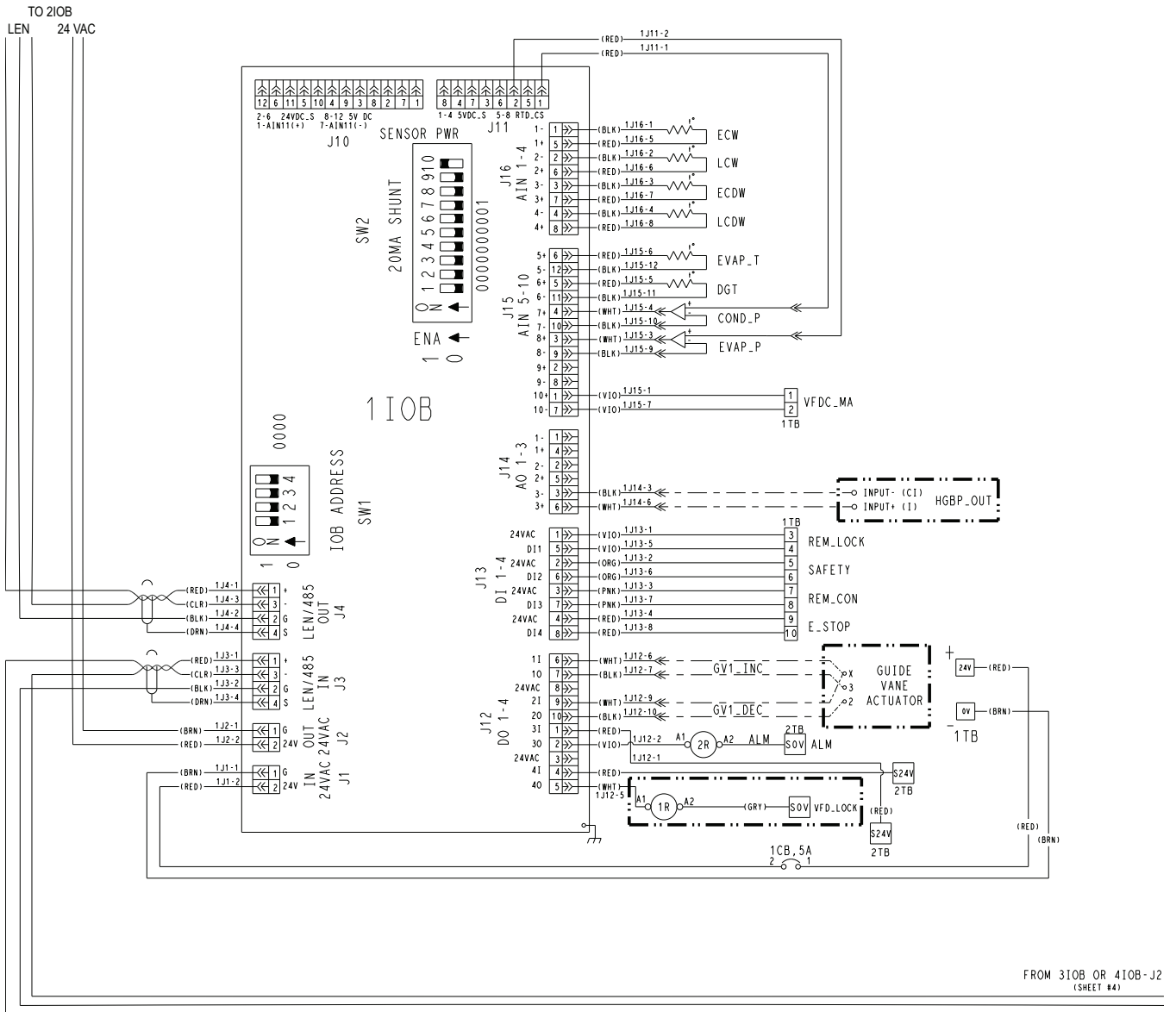

FROM DRAWING 19XR05044701 REV G

FROM 3IOB OR 4IOB-J2
(SHEET #4)

Fig. 4 — 19XR2-E IOB1

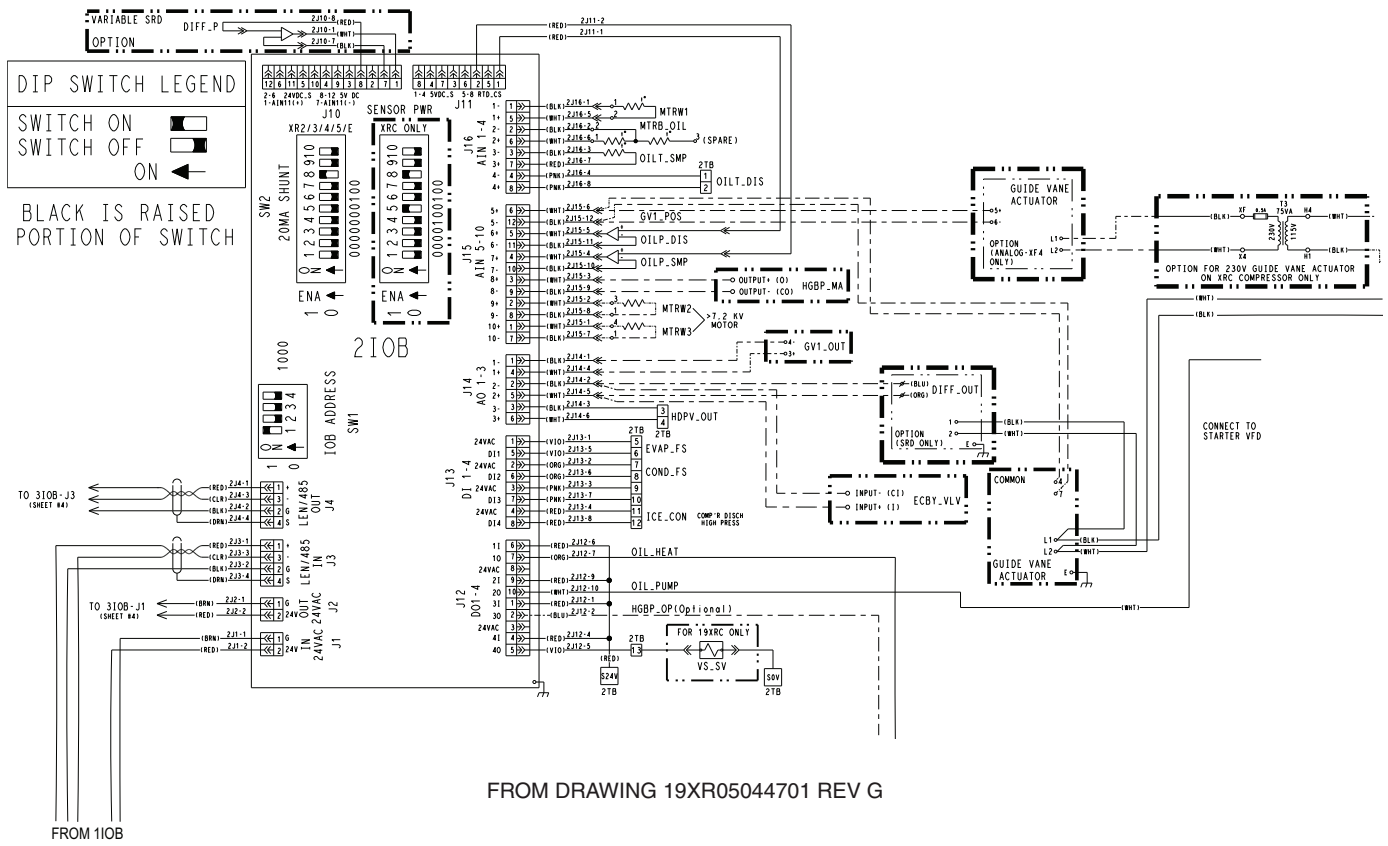
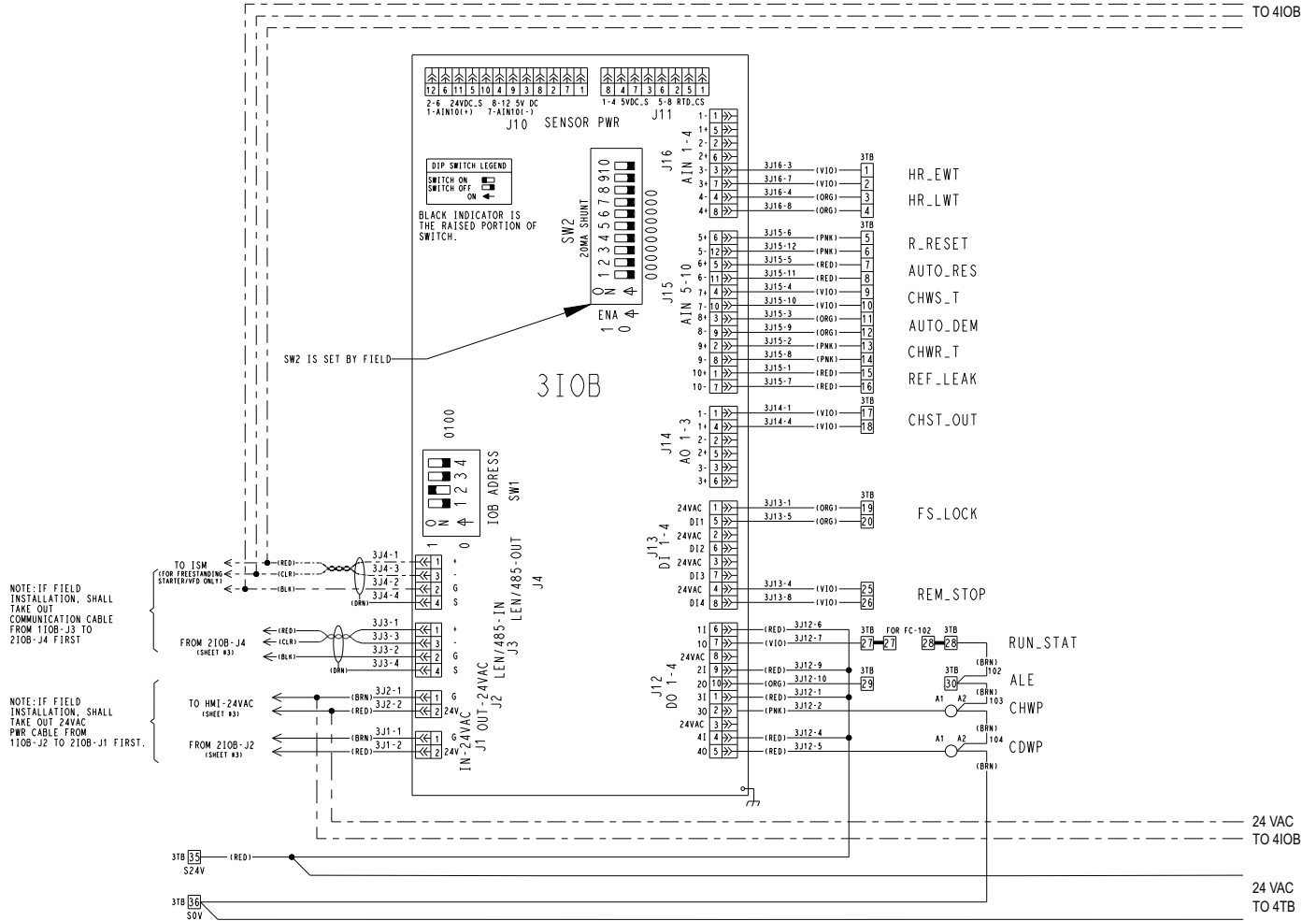

Fig. 5 — 19XR2-E IOB2

SENSORS ARE TO BE INSTALLED BY FIELD.

TO 4IOB



FROM DRAWING 19XR05044701 REV G

Fig. 6 — 19XR2-E IOB3

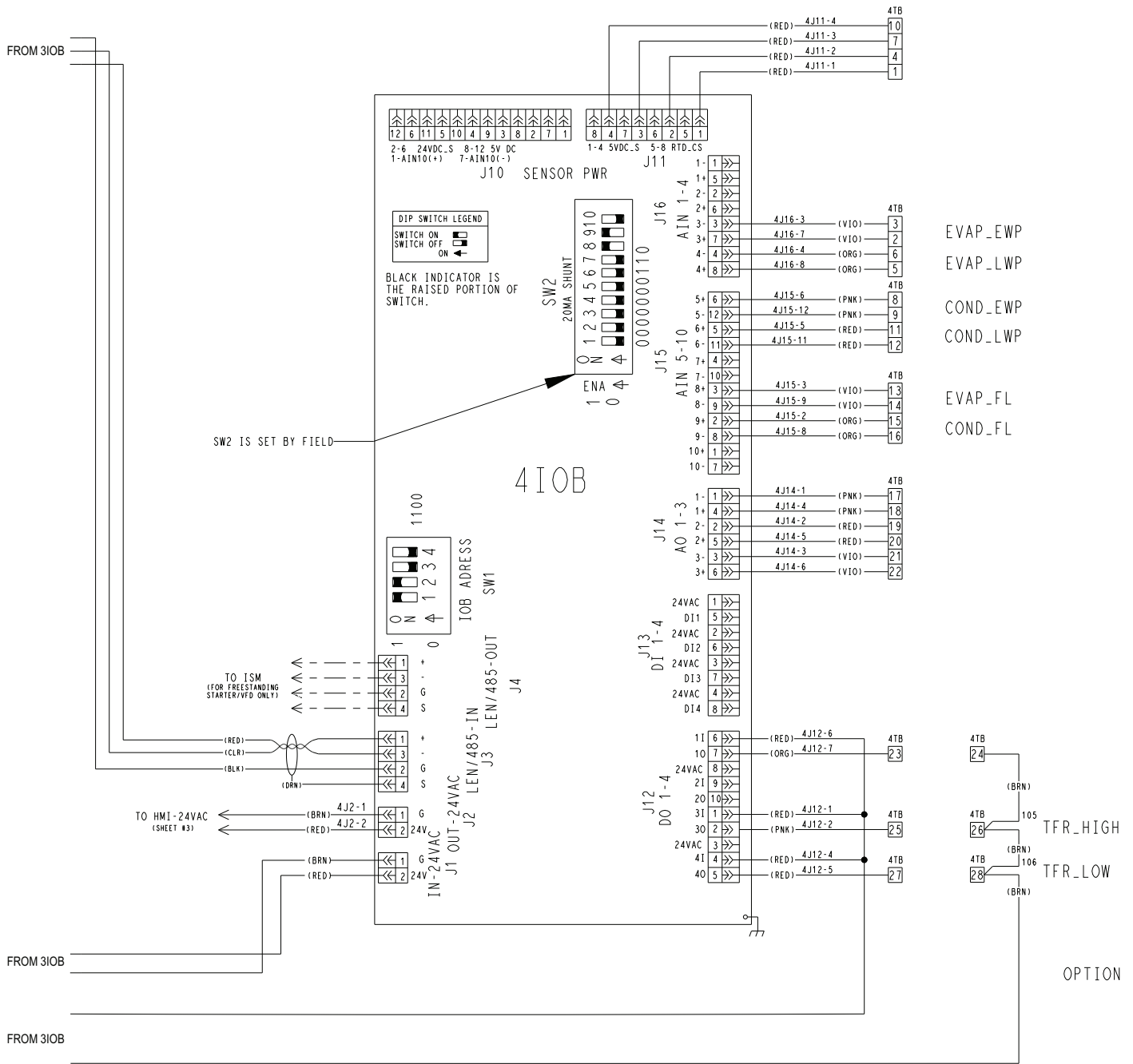

Fig. 7 — 19XR2-E IOB4

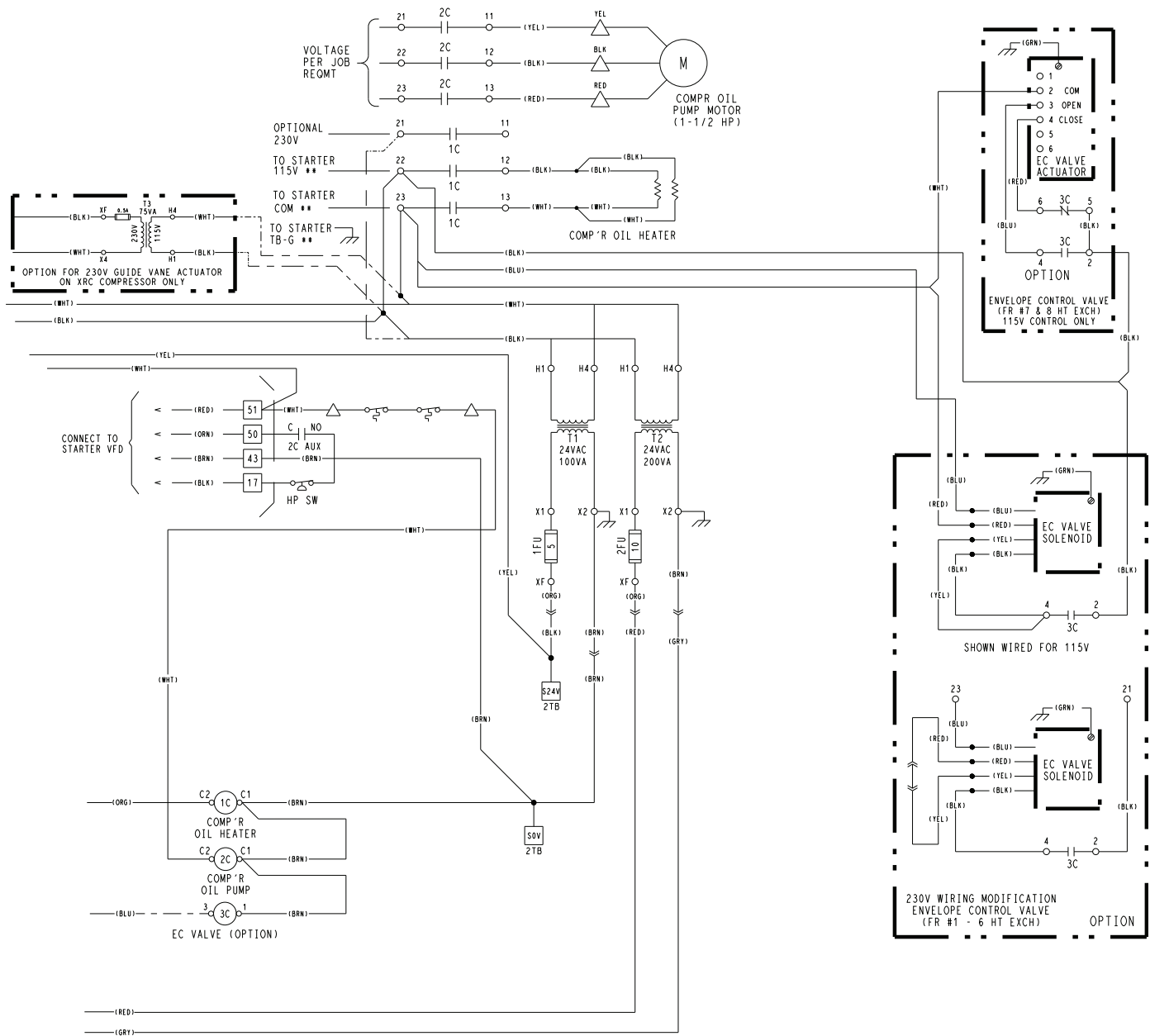

Fig. 8 — 19XR2-E Control Wiring

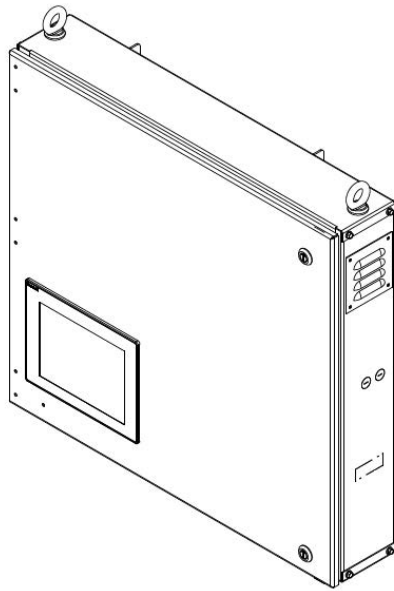

Fig. 9 — 19XR2-E Control Panel Front View

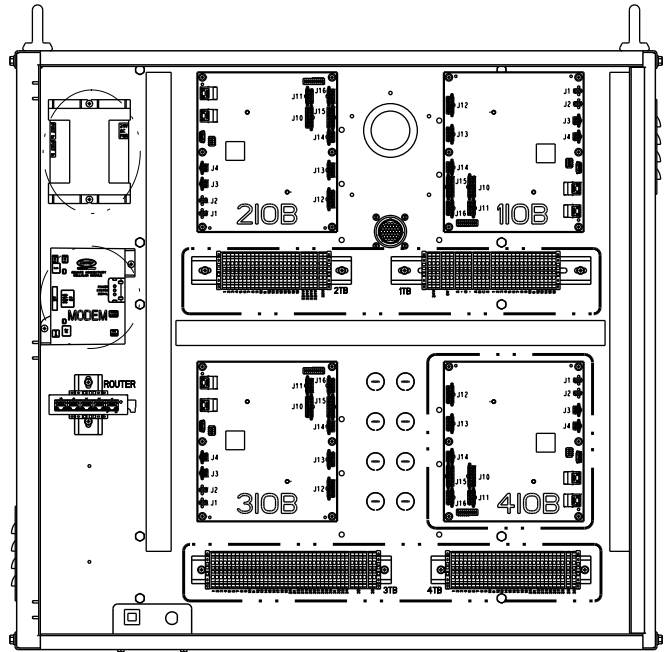

Fig. 10 — 19XR2-E Control Panel Layout

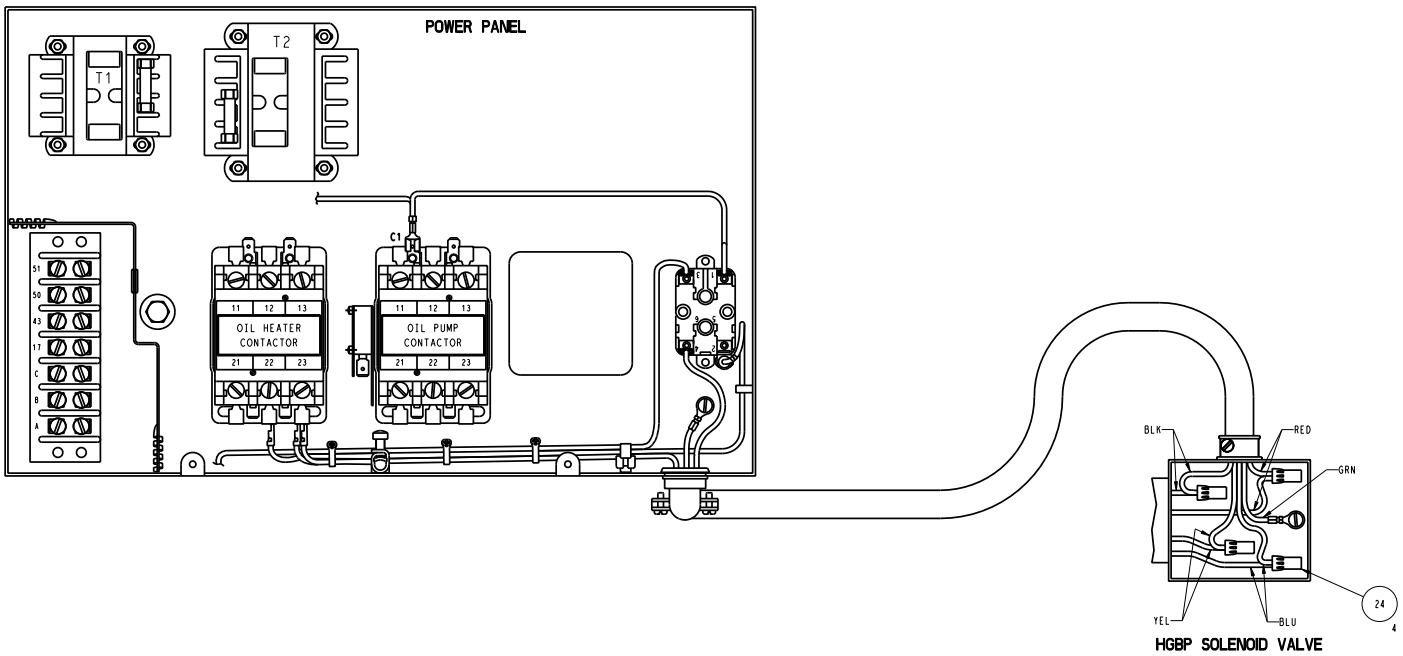

Fig. 11 — 19XR2-E Power Panel Layout

Table 7 — 19XR6/7 IOB1 Connections

DESCRIPTION	CHANNEL	TERMINAL	TYPE	OPTIONAL
Entering Chilled Water Temperature	AI1	J16-1,5	5 kΩ	—
Leaving Chilled Water Temperature	AI2	J16-2,6	5 kΩ	—
Entering Condenser Water Temperature	AI3	J16-3,7	5 kΩ	—
Leaving Condenser Water Temperature	AI4	J16-4,8	5 kΩ	—
Evaporator Refrigerant Liquid Temperature	AI5	J15-6,12	5 kΩ	—
Discharge Gas Temperature	AI6	J15-5,11	5 kΩ	—
Condenser Pressure	AI7	J15-4	5 VDC	—
Evaporator Pressure	AI8	J15-3	5 VDC	—
Economizer Pressure	AI9	J15-2	5 VDC	—
FS VFD Load Current	AI10	J15-1,7	4 to 20 mA	Yes
Chiller Status Output (ON=20mA, OFF=4mA, TRIPOUT=8mA, Not Off and Compressor not running=12mA)	AO1	J14-1,4	4 to 20 mA	Yes
Oil EXV Output	AO2	J14-2, 5	4 to 20 mA	Yes
Evaporator Water Flow Switch	DI1	J13-5 (4TB-1,2)	24 VAC	Yes, NO (dry contact)
Condenser Water Flow Switch	DI2	J13-6 (4TB-3,4)	24 VAC	Yes, NO (dry contact)
Remote Contact Input	DI3	J13-7 (4TB-5,6)	24 VAC	Yes, NO (dry contact); closed indicates start chiller signal
Remote Emergency Stop Input	DI4	J13-8 (4TB-7,8)	24 VAC	Yes, NO (dry contact); closed indicates stop chiller signal
Stage 1 IGV Increase	DO1	J12-7	24 VAC	Yes
Stage 1 IGV Decrease	DO2	J12-10	24 VAC	Yes
Chiller Alarm Relay	DO3	J12-2	24 VAC	Yes
Chiller Status (Discrete)	DO4	J12-5	24 VAC	Yes

LEGEND

EXV — Electronic Expansion Valve
FS — Fire Security
IGV — Inlet Guide Vane
IOB — Input/Output Board
NO — Normally Open
VFD — Variable Frequency Drive

NOTES:

1. See Fig. 12 for IOB1 wiring diagram.
2. For pressure readings, only Vout (output) terminal is indicated. See Fig. 12 for Vin (+) and ground (-).
3. Defaults are shown. In some cases the IOB can be configured differently depending on job requirements.

Table 8 — 19XR6/7 IOB2 Connections

DESCRIPTION	CHANNEL	TERMINAL	TYPE	OPTIONAL
Motor Winding Temperature 1	AI1	J16-1,5	5 kΩ	—
Motor Winding Temperature 2	AI2	J16-2,6	5 kΩ	—
Motor Winding Temperature 3	AI3	J16-3,7	5 kΩ	—
Oil Supply Temperature	AI4	J16-4, 8	5 kΩ	Yes
Oil Sump Temperature	AI5	J15-6,12	5 kΩ	—
Oil Supply Pressure	AI6	J15-5	5 VDC	—
Oil Sump Pressure	AI7	J15-4	5 VDC	—
Auto Demand Limit Input	AI8	J15-3,9	4 to 20 mA	Yes
Envelope Valve (HGBP) Feedback	AI9	J15-2,8	4 to 20 mA	Yes
Displacement Switch	AI10	J15-7	Ohm	—
Guide Vane 1 Output	AO1	J14-1,4	4 to 20 mA	—
Damper Valve Feedback Fully Open	DI1	J13-5	24 VAC	—
Damper Valve Feedback Fully Close	DI2	J13-6	24 VAC	—
High Pressure Switch	DI3	J13-7,3	24 VAC	—
Ice Build Contact	DI4	J13-8,4 (4TB-12)	24 VAC	Yes, NO (dry contact)
Oil Heater Relay	DO1	J12-7	24 VAC	—
Oil Pump Relay	DO2	J12-10	24 VAC	—
Economizer Damper Valve Open	DO3	J12-2	24 VAC	—
Economizer Damper Valve Close	DO4	J12-5	24 VAC	—

LEGEND

IOB — Input/Output Board
NO — Normally Open

NOTES:

1. See Fig. 13 for IOB2 wiring diagram.
2. For pressure readings, only Vout (output) terminal is indicated. See Fig. 13 for Vin (+) and ground (-).
3. Defaults are shown. In some cases the IOB can be configured differently depending on job requirements.

Table 9 — 19XR6/7 IOB3 Connections

DESCRIPTION	CHANNEL	TERMINAL	TYPE	OPTIONAL
Low Speed ME Bearing Temperature	AI1	J16-1,5	5 kΩ	—
Low Speed CE Bearing Temperature	AI2	J16-2,6	5 kΩ	—
High Speed ME Bearing Temperature	AI3	J16-3,7	5 kΩ	—
High Speed CE Bearing Temperature	AI4	J16-4,8	5 kΩ	—
Remote Reset Temperature	AI5	J15-6,12	5 kΩ	Yes
Guide Vane 1 Actual Position	AI6	J15-5,11	4 to 20 mA	—
Common Chilled Water Supply (CHWS) Temperature	AI7	J15-4, 10	5 KOhm	Yes
Auto Water Temperature Reset	AI8	J15-3,9	4 to 20 mA	Yes
Common Chilled Water Return (CHWR) Temperature	AI9	J15-2, 8	5 KOhm	Yes
Head Pressure Output	AO1	J14-1,4	4 to 20 mA	Yes
Head Pressure Output 2	AO2	J14-2,5	2 to 20 mA	Yes
EC/HGBP Valve Feedback Fully Open	DI1	J13-5	24 VAC	—
EC/HGBP Valve Feedback Fully Close	DI2	J13-6	24 VAC	—
Spare Safety	DI3	J13-7 (4TB-11,12)	24 VAC	Yes, NO (dry contact), normally open
EC/HGBP Solenoid / Open	DO1	J12-7	24 VAC	—
EC/HGBP Close	DO2	J12-10	24 VAC	—
Chilled Water Pump	DO3	J12-2	24 VAC	—
Condenser Water Pump	DO4	J12-5	24 VAC	—

LEGEND

CE — Compressor End
EC — Envelop Control
HGBP — Hot Gas Bypass
IOB — Input/Output Board
ME — Motor End
NO — Normally Open

NOTES:

1. See Fig. 14 for IOB3 wiring diagram.
2. For pressure readings, only Vout (output) terminal is indicated. See Fig. 14 for Vin (+) and ground (-).
3. Defaults are shown. In some cases the IOB can be configured differently depending on job requirements.

Table 10 — 19XR6/7 IOB4 Connections

DESCRIPTION	CHANNEL	TERMINAL	TYPE	OPTIONAL
Heat Reclaim Entering Temp	AI1	J16-1,5	5 VDC	Yes
Heat Reclaim Leaving Temp	AI2	J16-2,6	5 VDC	Yes
Entering Evaporator Water Pressure	AI3	J16-7	5 VDC	Yes
Leaving Evaporator Water Pressure	AI4	J16-8	5 VDC	Yes
Entering Condenser Water Pressure	AI5	J15-6	5 VDC	Yes
Leaving Condenser Water Pressure	AI6	J15-5	5 VDC	Yes
Refrigerant Leak Sensor	AI7	J15-4,10	4 to 20 mA	Yes
Evaporator Water Flow Measurement	AI8	J15-3, 9	4 to 20 mA	Yes
Condenser Water Flow Measurement	AI9	J15-2, 8	4 to 20 mA	Yes
Customer Alert	DI3	J13-3, 7	24 VAC	Yes, NO (dry contact)
Free Cooling Start Switch	DI4	J13-4, 8	24 VAC	Yes, NO (dry contact)
Free Cooling Mode	DO1	J12-7	24 VAC	Yes
Tower Fan High	DO3	J12-2	24 VAC	Yes
Tower Fan Low	DO4	J12-5	24 VAC	Yes

LEGEND

IOB — Input/Output Board
NO — Normally Open

NOTES:

1. See Fig. 15 for IOB4 wiring diagram.
2. For pressure readings, only Vout (output) terminal is indicated. See Fig. 15 for Vin (+) and ground (-).
3. Defaults are shown. In some cases the IOB can be configured differently depending on job requirements.

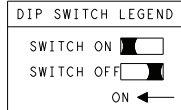

BLACK IS RAISED PORTION OF SWITCH

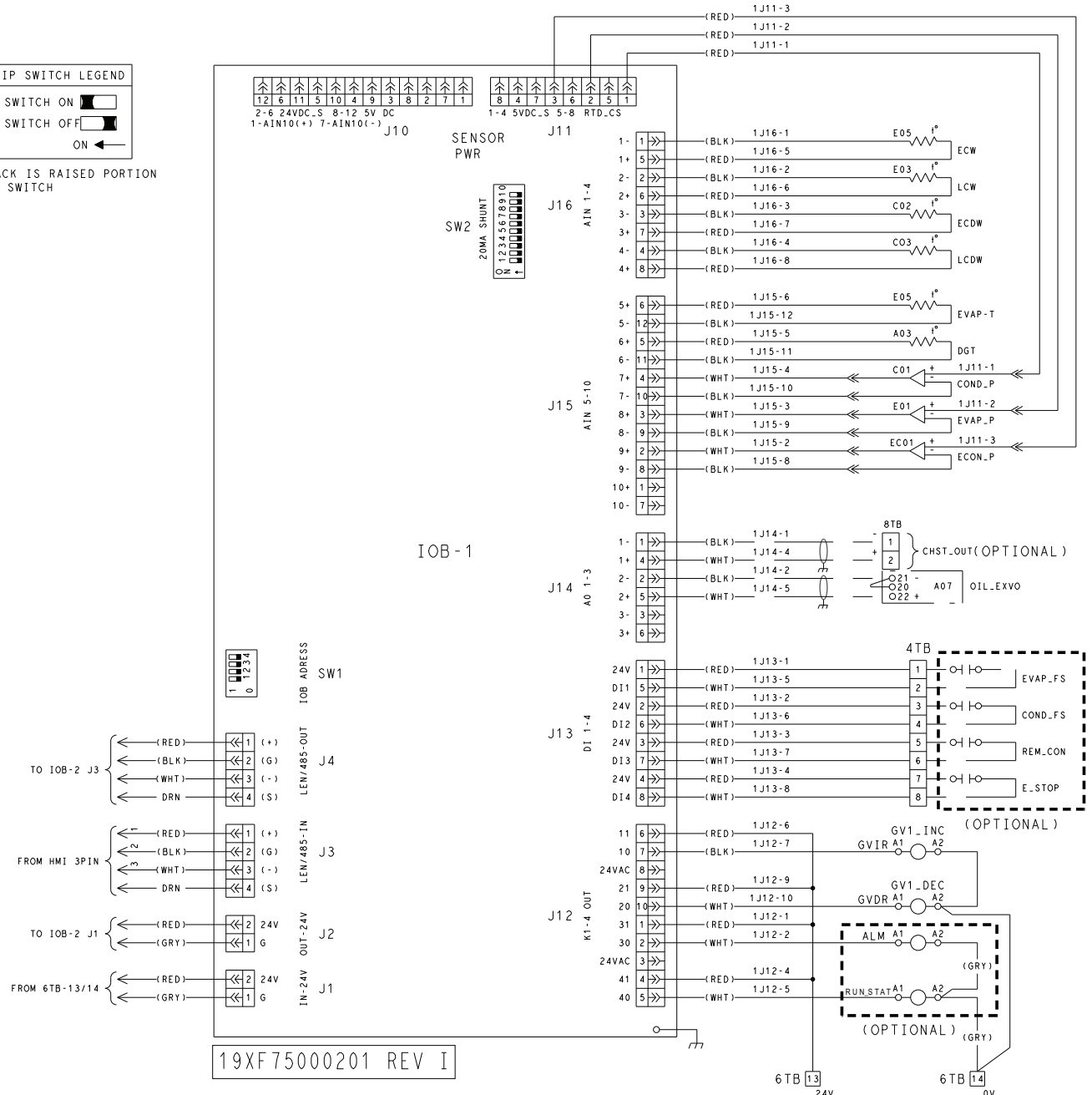

19XF75000201 REV I

NOTE: A suitable 24 VAC relay is Carrier part number 19XV05005503. Carrier recommends using a relay with a contact rating of 10 amp sealed RMS or greater.

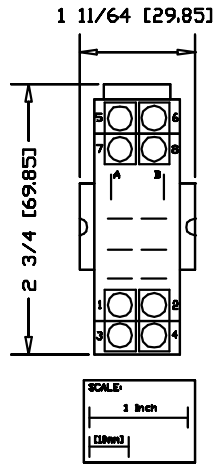

19XV05005503 BASE DIMENSIONS (REFERENCE) DIMENSIONS IN INCHES [MM]

PART NO.	NO. OF PIN
19X4003501	2 PIN
19X4003502	4 PIN
19X4003503	6 PIN
19X4003504	8 PIN
19X4003505	10 PIN
19X4003506	12 PIN

Fig. 12 — 19XR6/7 IOB1

LEGEND FOR FIG. 12-15

- COMPONENT TERMINAL
- CONDUCTOR MALE FEMALE CONNECTOR
- FIELD WIRING
- OPTIONAL WIRING
- COMPONENT/PANEL ENCLOSURE
- TERMINAL BLOCK FOR FIELD WIRING
- ∅ TERMINAL BLOCK FOR INTERNAL CONNECTION
- WIRE SPLICE

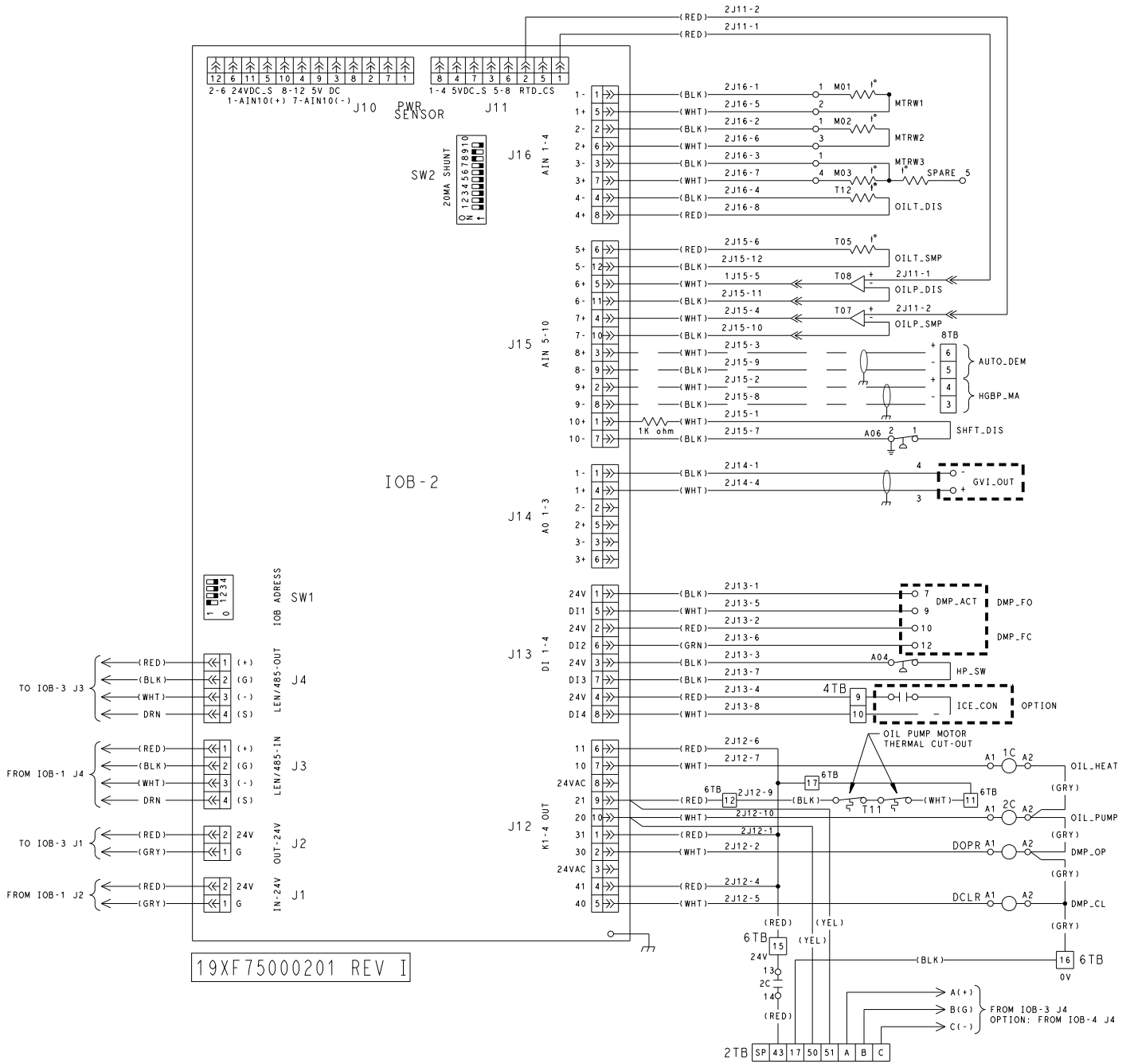

Fig. 13 — 19XR6/7 IOB2

CONNECTORS TO DAMPER VALVE - FERRULE
 CONNECTOR TO IGV - #16-22 FORK TERMINAL.

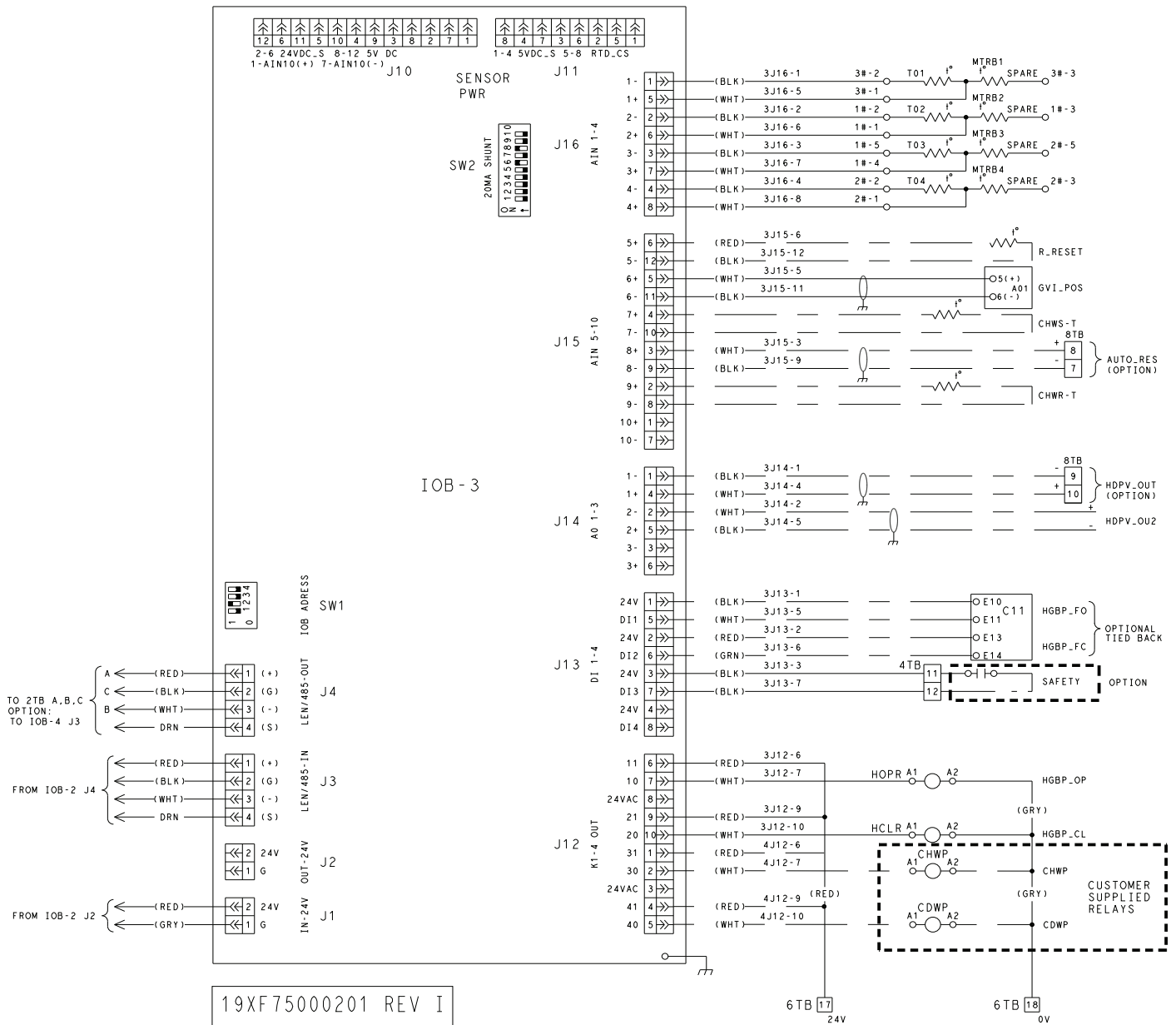
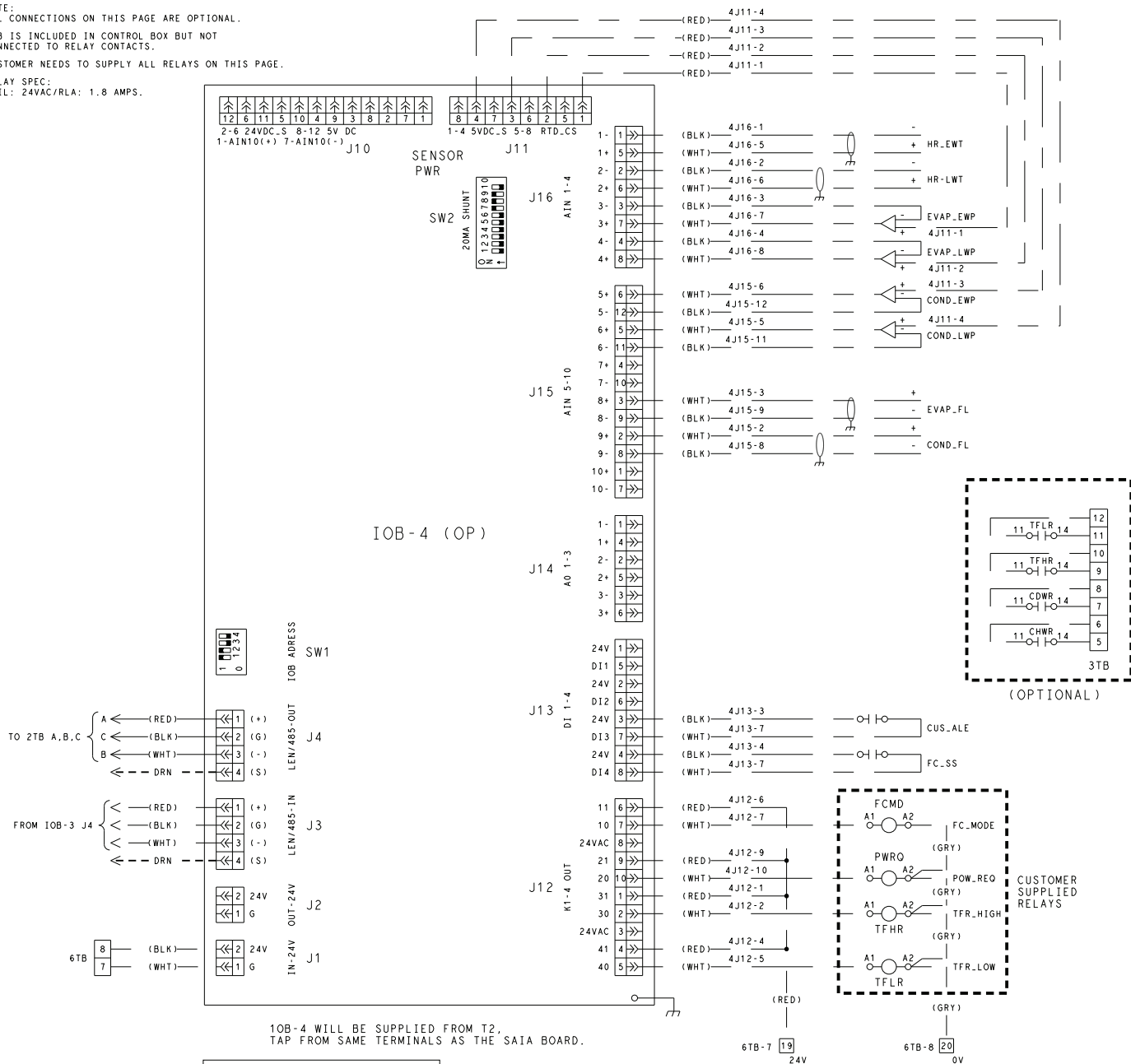

Fig. 14 — 19XR6/7 IOB3

NOTE:
 ALL CONNECTIONS ON THIS PAGE ARE OPTIONAL.
 3TB IS INCLUDED IN CONTROL BOX BUT NOT
 CONNECTED TO RELAY CONTACTS.
 CUSTOMER NEEDS TO SUPPLY ALL RELAYS ON THIS PAGE.
 RELAY SPEC:
 COIL: 24VAC/RLA: 1.8 AMPS.



19XF75000201 REV I

Fig. 15 — 19XR6/7 IOB4

LUG CAPACITY: 8AWG MAX

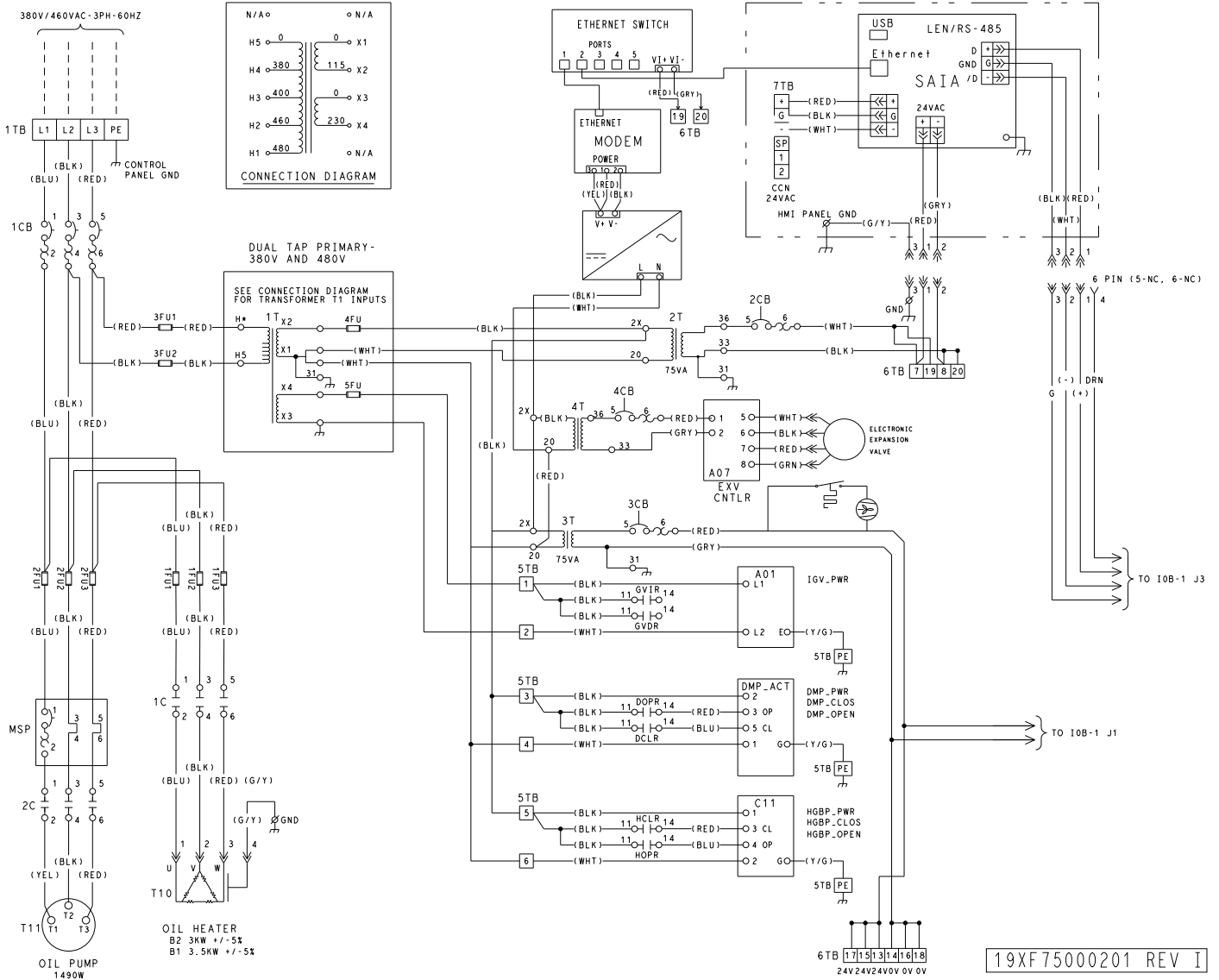

Fig. 16 — 19XR6/7 Control Wiring

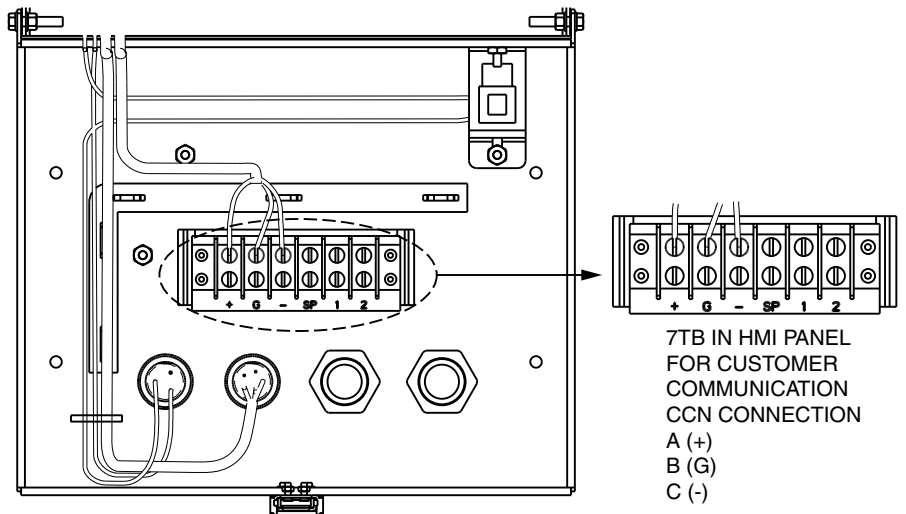

Fig. 17 — HMI Panel

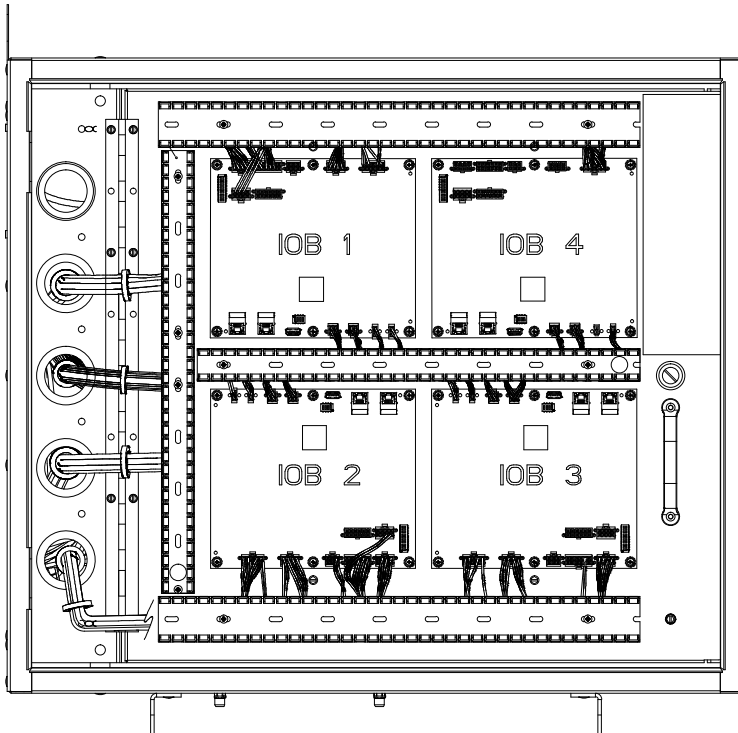

Fig. 18 — 19XR6/7 Control Panel, IOB Layer

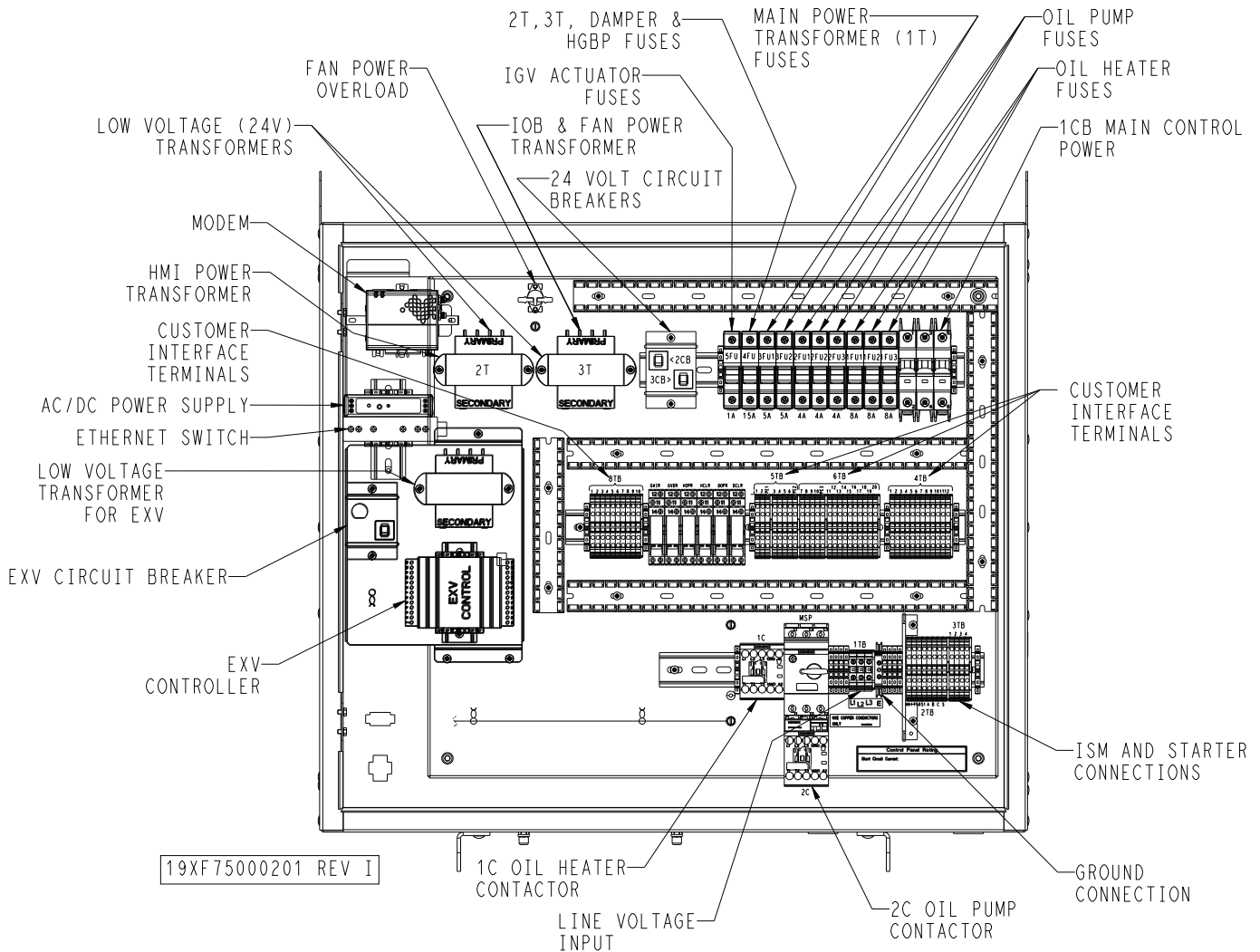

Fig. 19 — 19XR6/7 Control Panel, Bottom Layer

Sensors

PRESSURE TRANSDUCERS

Pressure transducers measure the pressures in the unit. These electronic sensors deliver 0 to 5 VDC. The transducers can be calibrated through the controller. The pressure transducers are connected to the IOBs. See Table 11.

Table 11 — Pressure Transducers

PRESSURE TRANSDUCER	PURPOSE
Evaporator	Measures evaporator pressure
Condenser	Measures condenser pressure
Economizer	Measures economizer pressure (if economizer)
Oil Supply	Measures oil pressure in the oil discharge piping
Oil Sump	Measures oil pressure in the oil sump
Evaporator Water Pressure Difference	(Optional) Measures pressure difference between entering and leaving water
Condenser Water Pressure Difference	(Optional) Measures pressure difference between entering and leaving water
Evaporator Entering Water	(Optional) Measures pressure of evaporator entering water
Evaporator Leaving Water	(Optional) Measures pressure of evaporator leaving water
Condenser Entering Water	(Optional) Measures pressure of condenser entering water
Condenser Leaving Water	(Optional) Measures pressure of condenser leaving water

TEMPERATURE SENSORS

The system uses electronic sensors to measure and control the temperatures in the unit. There are three types of temperature sensors: 5K thermistor, 10K thermistor, and RTD (resistance temperature detector, 100 ohm, 3-wire) based on IOB channel configurations. The temperature sensor range is -40°F (-40°C) to 245°F (118°C). See Table 12.

Table 12 — Temperature Sensors

TEMPERATURE SENSOR	PURPOSE
Entering Chilled Water	Measures entering evaporator water temperature
Leaving Chilled Water	Measures leaving evaporator water temperature
Entering Condenser Water	Measures entering condenser water temperature
Leaving Condenser Water	Measures leaving condenser water temperature
Evaporator Refrigerant Liquid	Measures evaporator refrigerant liquid temperature
Compressor Discharge	Measures compressor discharge temperature
Low Speed Motor End Bearing	Measures temperature of the low speed motor end bearing temperature (02XR6/7)
Low Speed Compressor End Bearing	Measures temperature of the low speed compressor end bearing temperature (02XR6/7)
High Speed Motor End Bearing	Measures temperature of the high speed motor end bearing temperature (02XR6/7)
High Speed Compressor End Bearing	Measures temperature of the high speed compressor end bearing temperature (02XR6/7)
Motor Winding End	Sensor(s) measure the temperature of each phase of the compressor motor
Oil Sump	Measures the compressor sump oil temperature
Oil Supply	Measures the oil temperature in the oil discharge piping
Compressor thrust bearing oil temperature sensor	Measure compressor thrust bearing oil temperature (02XR2-5, 02XRE)

NOTE: Text in parentheses indicates applicable product.

Controls Outputs

EVAPORATOR/CONDENSER WATER PUMP

The controller can regulate an optional evaporator/condenser water pump.

INLET GUIDE VANE

The inlet guide vane adjusts the refrigerant vapor flow into the compressor to adapt to change in the operating conditions of the machine. To adjust the refrigerant flow, the guide vane opens or closes to vary the cross-section of the refrigerant path. The high degree of accuracy with which the guide vane is positioned ensures that the flow of refrigerant is precisely controlled.

ECONOMIZER DAMPER VALVE

The economizer damper control opens or closes the economizer damper valve to maintain a minimum refrigerant pressure difference between the evaporator and economizer.

ENVELOP CONTROL/HGBP VALVE

The hot gas bypass function artificially loads the chiller and keeps it running under low load conditions or helps to prevent surge conditions. Since this function can also reduce the operating efficiency of the machine, this is a user-selectable and configurable option.

ECONOMIZER BYPASS VALVE

The economizer bypass control opens the liquid bypass valve to allow liquid refrigerant to bypass the economizer and allow the chiller to operate as a single-stage system.

VFD

The VFD modifies motor frequency to allow compressor start-up and capacity control. The VFD controls continually monitor parameters in order to ensure compressor protection. Should a problem occur, the controller triggers an alarm and the compressor is stopped.

PIC 6 USER INTERFACE

The PIC 6 Human Machine Interface (HMI) is a color 10.4-in. TFT touch screen. Navigation is either direct from the touch screen interface or by connecting to a web interface at the Ethernet IP port of the controller. The navigation menus are the same for both connection methods.

Web Connection

Two web connections may be authorized at the same time. When two users are connected simultaneously, there is no priority between users; that is, the last modification is in effect regardless of the user.

Connection is from a personal computer using a Java-enabled web browser. See the section Settings for the Controller on page 55 for configuration instructions. The minimum browser configuration includes:

- Microsoft Internet Explorer (version 8 or higher) or Mozilla Firefox (version 3.5.2 or higher). In the advanced connection options, add the unit address to the address list. Do not use a proxy server.
- Java platform (version 6 or higher). In the control panel, deselect (uncheck) the option that allows storing temporary internet files and use a direct connection.

To access the PIC 6 user interface, enter the IP address of the unit in the address bar of the web browser. The IP address, Subnet Mask, and Gateway can be viewed or changed from the PIC 6 interface. For more information on the web browser and Java platform configuration, see the Diagnostics and Troubleshooting section.

General Interface Features

ICONS

Table 13 shows general interface icons.

Table 13 — Interface Icons

ICON	MEANING
	Green: Indicates unit is running Gray: Indicates unit is off
	Home
	Main menu
	Indicates user is logged off
	Indicates user is logged in
	Gray: Indicates no alarm or alert is active Red: Indicates alarm or alert
	Back (not visible in main menu)
	Previous and next screen

LEGEND

- 1 — Home Screen Access Button
- 2 — Main Menu Access Button
- 3 — User Login Screen Access Button
- 4 — Unit Start/Stop Access Button
- 5 — Alarm Menu Access Button
- 6 — Condenser Saturated Temperature and Pressure
- 7 — Evaporator Saturated Temperature and Pressure
- 8 — Guide Vane Position Percentage
- 9 — Unit Capacity Percentage (Motor Load Current Percentage)
- 10 — Set Point
- 11 — Evaporator Pump Status (Hydraulic System Option is Enabled)
- 12 — Evaporator Water Inlet and Outlet Temperature
- 13 — Oil Pressure Delta
- 14 — Oil Temperature
- 15 — Condenser Pump Status (Hydraulic System Option is Enabled)
- 16 — Condenser Inlet and Outlet Temperature

SCREENS

The Human Machine Interface includes the following screens:

- Home screen, which displays the main parameters
- Menu screens for navigation
- Data/configuration screens, which list the parameters by type
- Operating mode selection screen
- Password entry and language selection screen
- Parameter modification screen
- Time schedule screen

If the interface is not used for a long period, it goes into screen-saver mode and displays a black screen. However, the control is always active and the unit operating mode remains unchanged. When the user presses the black screen, the Home screen is displayed.

Home Screen

The Home Screen (see Fig. 20) is displayed when the unit is switched on or when the user presses the screen when the interface has gone into screen-saver mode. The Home Screen displays the current software version number. To exit from this screen, press the Home icon

System Overview (Home) Screen

Figure 20 shows the system overview screen. Press a component image to see current status. This screen is also displayed when the user presses the screen after the interface has gone into screen-saver mode. For details, see Status Display Screens on page 24.

Messages

The Set Point screen, On/Off screen, User Login screen, and Main Menu screens described in the next sections may display status messages at the bottom of the screen. See Table 14.

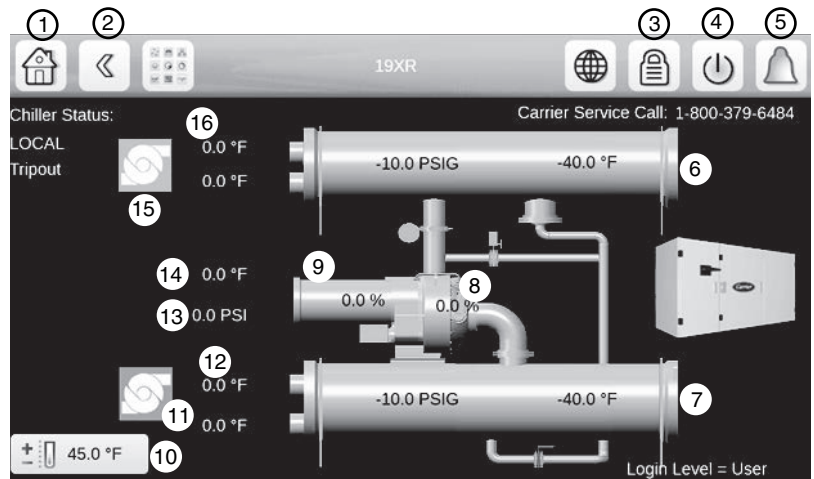

Fig. 20 — System Overview (Home) Screen

Table 14 — Status Messages

MESSAGE	STATUS
COMMUNICATION FAILURE!	Equipment controller did not respond while reading the table content.
ACCESS DENIED!	Equipment controller does not allow access to one of the table data blocks.
LIMIT EXCEEDED!	The value entered exceeds the table limits.
Save changes?	Modifications have been made. The interface waits to confirm exit; press Save or Cancel.
HIGHER FORCE IN EFFECT!	Equipment controller rejected a Force or Auto command because the interface force level is lower than that of the equipment controller.

Set Point Screen

The Set Point screen displays the current set point table. See Fig. 21. For more information about these settings, see the Set Point section on page 28.

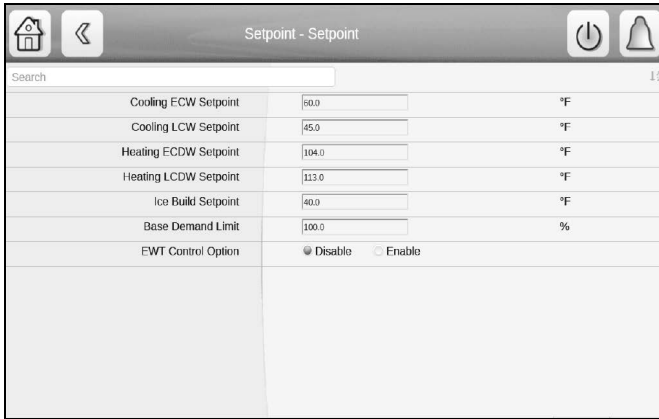

Fig. 21 — Set Point Screen

Unit Start/Stop Screen

The Unit Start/Stop screen allows the user to select the unit operating mode.

For unit start-up, with the unit in Local Off mode, press the gray Off icon to display the list of operating modes. Select the required mode to start up the chiller. See Fig. 22.

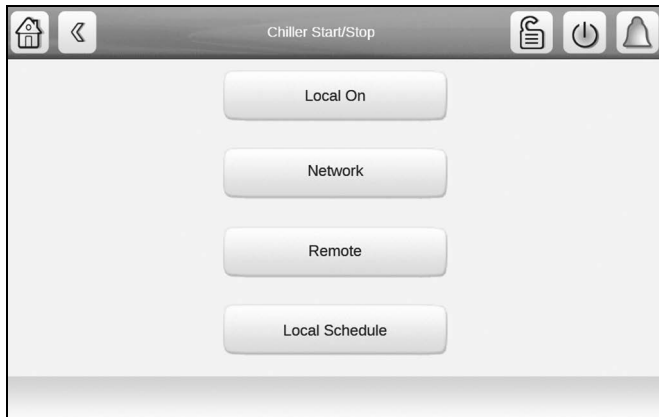

Fig. 22 — Unit Start/Stop Screen

When a start-up mode is selected, a status screen displays the progress of the start-up sequence (Fig. 23).

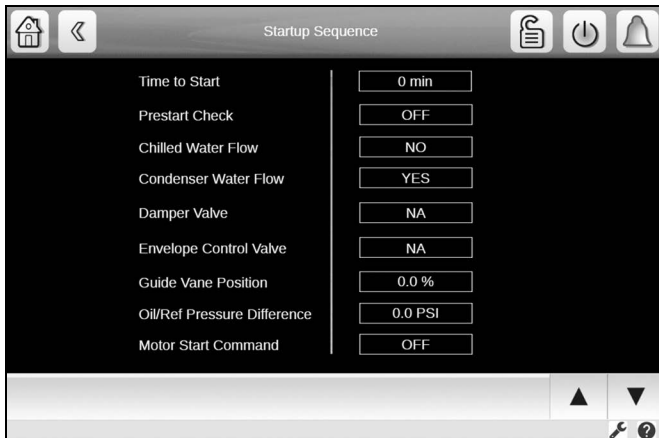

Fig. 23 — Start-Up Sequence Progress

To stop the unit, press the green On icon. Then press Confirm Stop to stop the unit, or press the Back icon to cancel the stop and return to the previous screen. See Fig. 24.



Fig. 24 — Confirm Stop

User Login Screen

Use this screen to login or log off and to set interface language and measurement system. See Fig. 25. There are three levels of password access:

- Basic access allows the user to view all data without a password.
- User access gives the user the additional ability to view and change many configuration settings, including set points and schedules. The default User password is 1111.
- Pressing the Service Login icon gives access to the Service Password entry and the Factory Login (separate icon). NOTE: Service Password is a 7-day expiration Service level password. This must be generated by the SmartService Administrator. Access to the Factory Login requires a SMART-Service application. Factory level login has access to critical factory configuration settings.

Upon entering correct password, select green checkmark and the Login Level will be updated accordingly.



NOTE: Password is validated after user presses the log-in icon.

Fig. 25 — User Login Screen

Main Menu Screen



To access the Main Menu screen, press the Main Menu icon . Press the icons on the screen to access the appropriate table or menu. Press the arrows at the bottom right corner, if present, to navigate through pages of tables. The options shown on the Main Menu screen depend on the user's level of access. Figure 26 shows the Main Menu screen as it appears for the User level of access.



Fig. 26 — Main Menu Screen (User Access)

Configuration Screen

To access the Configuration menu, press the Configuration icon  on page 2 of the Main Menu (User, Service, or Factory access level). The Configuration menu opens. Then press the General Configuration icon  on the Configuration menu. Press the arrows at the bottom right corner to navigate through pages. See Fig. 27. (Certain configuration settings are available only for Service or Factory access levels.) Refer to Appendix A, page 67, for more information about Configuration options.

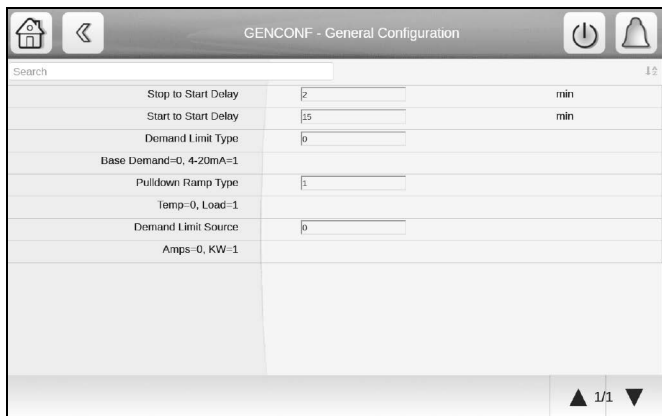

Fig. 27 — General Configuration Screen

After changing a value, press Return. The Save and Cancel icons are displayed. Press the Save icon to save the changed value. Figure 28 shows an example.

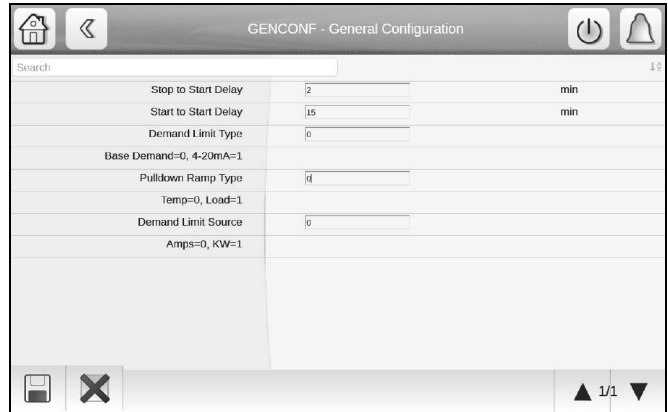



Fig. 28 — Saving a Change (General Configuration)

Schedule Menu Screen

To access the Schedule menu screen, press  on the Configuration menu screen. Select Local Schedule, Ice Build Schedule, or Network Schedule as applicable. Press the arrows at the bottom right corner to navigate through the time periods. See Fig. 29.

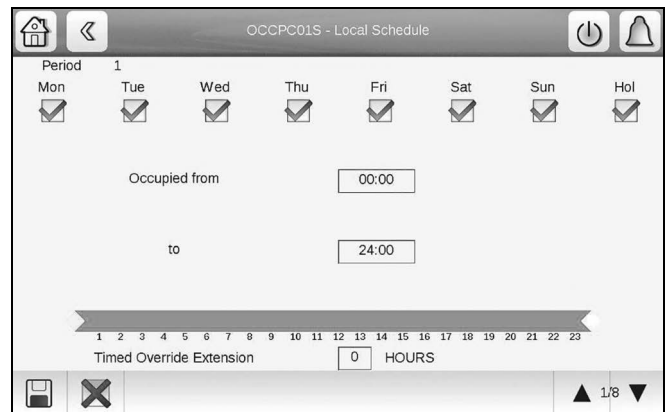

Fig. 29 — Local Schedule Menu Screen

Status Display Screens

Figure 30 shows the system status overview (home) screen. Press any component on the screen to see the status of that component. Press the arrows at the bottom right corner to navigate through the component status displays. Figures 31-38 show the component status displays.

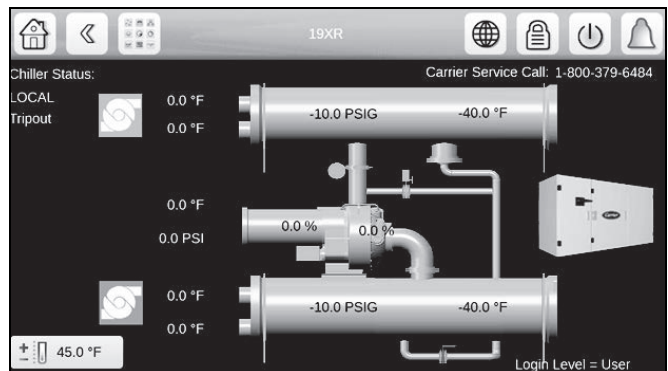

Fig. 30 — System Overview (Home) Screen

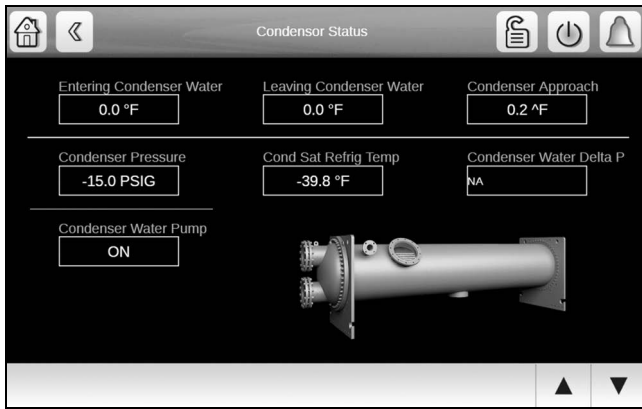

Fig. 31 — Condenser Status



Fig. 32 — Evaporator Status

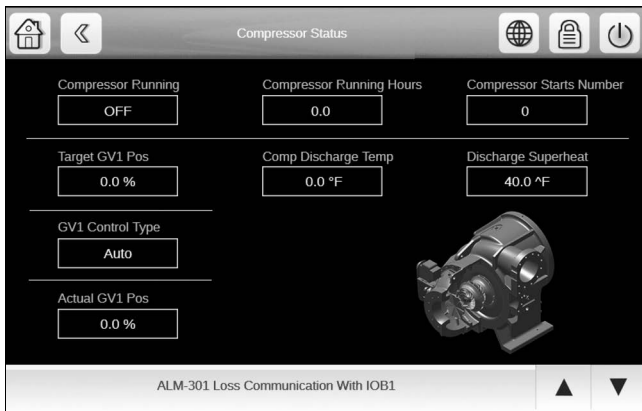

Fig. 33 — Compressor Status

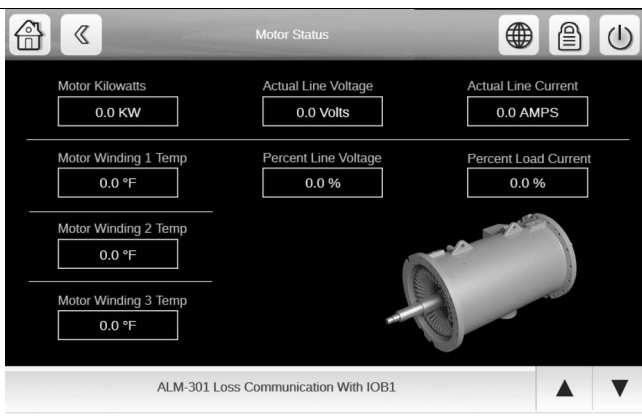
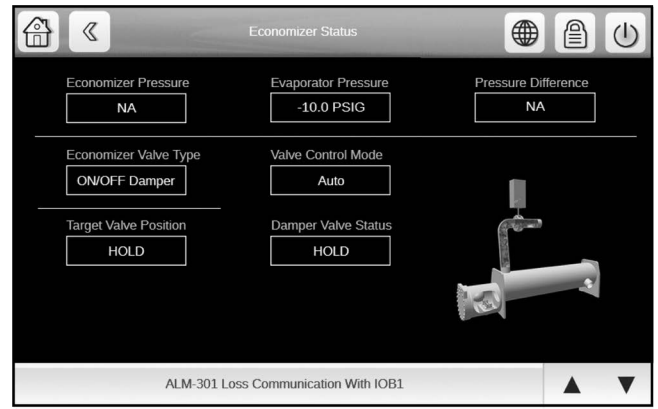

Fig. 34 — Motor Status



NOTE: The pressure difference shown in this screen is the difference between economizer pressure and evaporator pressure.

Fig. 35 — Economizer Status



Fig. 36 — Transmission Status

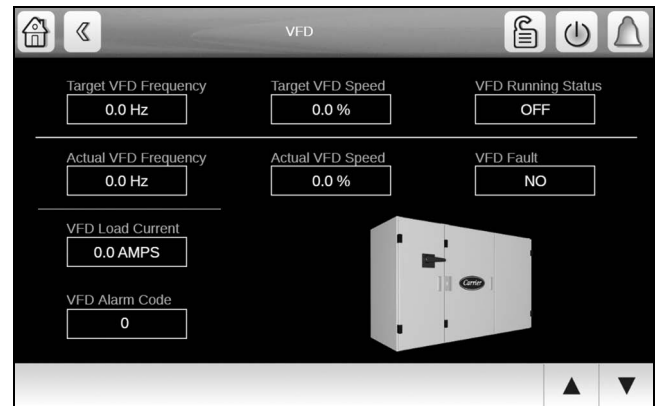

Fig. 37 — VFD Status

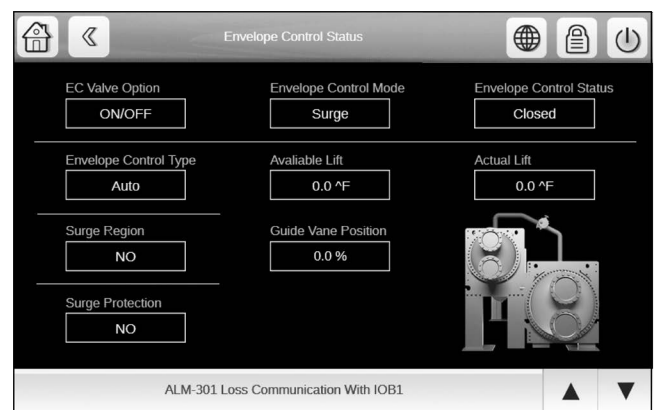

Fig. 38 — Envelop Control /HGBP Status

PIC 6 CONTROL OPERATION

Start-Stop Control

This function controls the chiller START-STOP command. The four selectable control modes are as follows: LOCAL, LOCAL SCHEDULE, REMOTE, or NETWORK. See Unit Start/Stop Screen on page 23. Specific control sources are valid to start or stop the chiller for each control mode.

LOCAL

When the control mode is LOCAL, the chiller can be started by the “Local ON” button on the PIC 6 interface screen, and can be shut down by the Confirm Stop button on the screen or by the EMSTOP software point.

LOCAL SCHEDULE

When the control mode is LOCAL SCHEDULE, the chiller will be started automatically if the configurable local schedule is Occupied. The chiller can be shut down by the unoccupied schedule, the Stop button on the PIC 6 interface screen, or by the EMSTOP software point.

REMOTE

When the control mode is REMOTE, the chiller will be started by the remote discrete input (REM_CON) located on the I/O board. The chiller can be shut down by the remote discrete input, the Stop button on the PIC 6 interface screen, or by the EMSTOP software point.

NETWORK

When the control mode is NETWORK, the chiller can be started and stopped by the CHIL_S_S and CHIL_OCC software points, which are written by other equipment through network commands and network schedule (both must be TRUE for chiller to start). To shut down the chiller, use the EMSTOP software point or stop using the HMI.

NOTE: There is a STOP OVERRIDE point in the GENUNIT table. If this point is enabled the chiller cannot be started.

Compressor Run Status

Compressor run status is shown at the top of the system overview (home) screen. Table 15 lists the chiller status numbers, names, and descriptions.

Chiller Start-Up Sequence

PRE-START CHECK

Once start-up begins, the controller performs a series of pre-start tests to verify that all pre-start alerts and safeties are within limits. Progress is shown on the Startup Sequence screen (see Fig. 39). This screen can be accessed by touching the mode title (top blue bar) of the home screen. Table 16 lists pre-start alert and alarm conditions.

The compressor RUN STATUS parameter on the default screen line now reads PRESTART. If a test is not successful, the start-up is delayed or aborted. If all tests are successful, the chilled water pump relay energizes, and the main screen line now reads STARTUP.

Table 15 — Compressor Run Status

STATUS NO.	STATUS NAME	DESCRIPTION
0	OFF	STATSTOP is STOP, no alarm.
1	CTLTEST	Controls Test is active.
2	PUMPDOWN	Pumpdown is active.
3	LOCKOUT	Lockout is active.
4	RECYCLE	Recycle shutdown completed on low load in effect until the need for cooling resumes; non-fault condition.
5	TRIPOUT	Shutdown completed due to alarm fault condition.
6	TIMEOUT	The controller is delaying the start sequence until the Start to Start or Stop to Start timers have elapsed.
7	PRESTART	The chiller is in the process of system checking before energizing the compressor motor.
8	STARTUP	Normal start-up in progress.
9	AUTORST	Auto Restart in progress.
10	RAMPING	Ramp loading in progress. The chiller has started and is gradually increasing its load to control electrical demand charges.
11	RUNNING	The chiller has completed ramp loading following start-up. Normal running mode, no override or demand limit.
12	OVERRIDE	Running with Override active.
13	DEMAND	Running with Demand Limit active. The chiller is prevented from loading further because it has reached an AVERAGE LOAD CURRENT limit or a MOTOR KILOWATTS limit.
14	SHUTDOWN	Compressor shutdown in progress.
15	FREECOOL	Free cooling in progress.
16	CONDFLSH	Condenser Flush in Progress (Note: Available for “Marine Option” only).

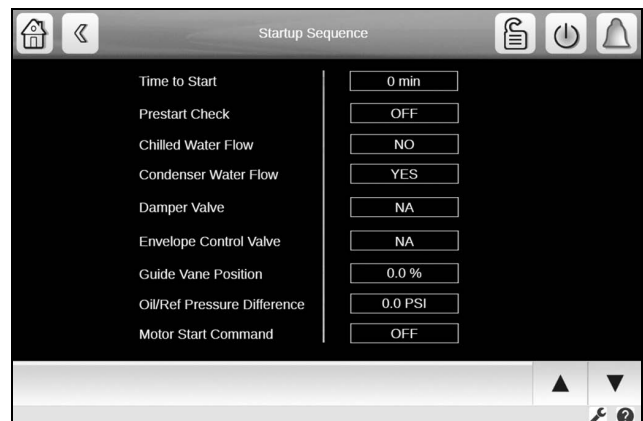

Fig. 39 — Start-Up Sequence Screen

Table 16 — Pre-Start Alerts and Alarms

PRE-START ALERT CONDITION	STATE NO.	ALARM OR ALERT
STARTS IN 12 HOURS >= 8	100	Alert
OIL SUMP TEMP <= 140°F (60°C) AND OIL SUMP TEMP <= EVAP_SAT + 50°F (27.8°C)	101	Alert
CONDENSER PRESSURE >= COND PRESS OVERRIDE – 20 psi	102	Alert
Number of recycle restart in the last 4 hours is greater than 5	103	Alert
COMP BEARING TEMP >= COMP BEARING ALERT– 10°F (5.5°C)	230	Alarm
COMP MOTOR WINDING TEMP >= MOTOR TEMP OVERRIDE – 10°F (5.5°C)	231	Alarm
COMP DISCHARGE TEMP >= COMP DISCHARGE ALERT– 10°F (5.5°C)	232	Alarm
EVAP_SAT < Evap trip point* + EVAP OVERRIDE DELTA T or EVAP REFRIG LIQUID TEMP < Evap trip point* + EVAP OVERRIDE DELTA T	233	Alarm
ACTUAL LINE VOLTAGE <= UNDERVOLTAGE THRESHOLD (n/a for UM VFDs)	234	Alarm
ACTUAL LINE VOLTAGE >= OVERVOLTAGE THRESHOLD (n/a for UM VFDs)	235	Alarm
Guide vane 1 has not been calibrated successfully	236	Alarm

*Evap trip point = 33°F (0.6°C) (water) or EVAP REFRIG TRIPPOINT (brine).

START-UP

One second after the successful pre-start check, the chilled water and condenser water pump relays are energized.

Five seconds later, the control monitors the chilled water and condenser water flow devices and waits until the WATER FLOW VERIFY TIME (service-configured, default 5 minutes) expires to confirm water flow.

After water flow is verified, the water temperature is compared to CONTROL POINT + 1/2 CHILLED WATER DEADBAND. If the temperature is less than or equal to this value, the control turns off the condenser pump relay and goes into RECYCLE mode.

If the RECYCLE condition is not satisfied, the start-up sequence continues and checks the guide vane position. For a single-stage compressor (Comp [Single = 0, Dual = 1] = 0 in FACTORY configuration), if the guide vanes are more than “GUIDE VANE CLOSURE AT STARTUP (default 4%)” % open, the start-up waits until the controller closes the vanes. For a dual-stage compressor (Comp [Single = 0, Dual = 1] = 1 in FACTORY configuration), the guide vanes are opened to the initial position specified with GV1 Closure at Startup in the Option Configuration menu.

If an EC/HGBP or economizer damper valve is equipped and enabled, the control checks that the position of these valves is fully closed.

If the vanes and valves position are verified and the oil pump pressure difference is less than 6 psi (41.4 kPa), the oil pump relay is energized.

The control then waits until the oil pressure difference (OIL PRESS VERIFY TIME, operator-configured, default 40 seconds) reaches a maximum of 18 psi (124 kPa). After oil pressure is verified, the control waits 40 seconds for oil prelube, and the compressor start relay energizes to start the compressor.

Chiller Shutdown Sequence

Chiller shutdown begins if any of the following occurs:

- Local OFF button is pressed
- A recycle condition is present (see the previous section)
- The time schedule has gone into unoccupied mode when in either Network or Local Schedule control mode
- The chiller protective limit has been reached and chiller is in alarm
- The start/stop status (CHIL_S_S) is overridden to stop from the network when in Network mode
- Remote contact is opened (assumes that chiller is operating in Remote mode)

If the chiller is normally shut down from running, a soft-stop shutdown will be performed. The soft-stop feature closes the guide vanes of the compressor automatically if a non-alarm stop signal occurs before the compressor motor is deenergized.

If the compressor is directed to STOP (except in cases of a fault shutdown), the guide vanes are directed to close and VFD will be commanded to minimum speed for a variable speed compressor. The compressor shuts off when any of the following is true:

- PERCENT LOAD CURRENT (%) drops below the SOFT STOP AMPS THRESHOLD
- ACTUAL GUIDE VANE POSITION drops below 4%
- Four minutes have elapsed since the stop was initialized

When any of these conditions is true, the shutdown sequence stops the compressor by deactivating the compressor start relay. The guide vanes are then commanded to the fully closed position. The oil pump relay will be turned off after 120 seconds post-lube.

Finally, the chilled water/brine pump and condenser water pump are shut down.

Oil Lubrication Control

As part of the pre-start checks executed by the controls, the oil sump temperature is compared to the evaporator saturated refrigerant temperature. If the oil temperature is less than 140°F (60°C) and less than evaporator saturated refrigerant temperature plus 50°F (27.8°C), the start-up will be delayed until either of these conditions is no longer true. Once this temperature is confirmed, the start-up continues.

The oil heater relay is energized whenever the chiller compressor is off and the oil sump temperature is less than 140°F (60°C) or the oil sump temperature is less than the evaporator saturated refrigerant temperature plus 53°F (29.4°C). The oil heater is turned off when either of the following conditions is true:

- Oil sump temperature is more than 152°F (66.7°C)
- Oil sump temperature is more than 144°F (62.2°C) and more than the evaporator saturated refrigerant temperature plus 55°F (30.6°C).

The oil heater is always off when the compressor is running.

The Oil Stir Cycle controls the oil pump when the compressor is not running but the oil heater is on. The oil pump is energized at various time periods in order to stir the oil for more evenly distributed heating. The Oil Stir Cycle has 4 operation modes:

- 0 → No Oil Stir
- 1 → Oil Stir for 30 seconds per 30 minutes
- 2 → Oil Stir for 1 minute per 4 hours
- 3 → Oil Stir for first 50 hours of chiller in not running status (as Option 1) followed by no Oil Stir (as Option 0)

19XR2-E chillers always operate as Option 1 (the oil pump is energized for 30 seconds after each 30 minutes of the oil heater being on).

19XR6/7 chillers are set to Option 1 by default but any of the 4 operating modes may be selected by the User.

Control Points

SET POINT

The set point can be configured at the Setpoint menu (“USER” access level).

The set point is determined by the heat/cool mode, EWT (entering water temperature) option, and ice build option. See Table 17.

Table 17 — Set Point Determination

EWT CONTROL OPTION	HEAT/COOL MODE	
	COOLING	HEATING
Disabled	Cooling LCW Set Point	Heating LCDW Set Point
Enabled	Cooling ECW Set Point	Heating ECDW Set Point

NOTES:

1. The ice build option is disabled when heat/cool mode is set to Heating.
2. When the ice build option is enabled and ice build is active, the control point is the Ice Build Set Point and the controlled water temperature is the leaving chilled water temperature.

CONTROL POINT TEMPERATURE

Capacity control is based on achieving and maintaining a control point temperature, which is the sum of a valid set point (from the SETPOINT screen) and a temperature reset value. In Cooling mode, the control point temperature is equal to the set point plus temperature reset. In Heating mode, the control point temperature is equal to the set point minus temperature reset.

The control point can be viewed directly on the main screen or the General Parameters menu.

TEMPERATURE RESET

Three types of chilled water or brine reset are available and can be viewed or modified on the Reset Configuration screen.

The default screen indicates when the chilled water reset is active. The control point Reset on the General Parameters screen indicates the amount of reset.

To activate a reset type, access the Reset Configuration (RESETCFG) screen and input all configuration information for that reset type.

Reset Type 1: 4 to 20 mA Temperature Reset

Reset Type 1 is an automatic reset utilizing a 4 to 20 mA analog input signal provided from any external sensor, controller, or other device which is appropriately configured. For this type, Degrees Reset At 20 mA is configured in the RESETCFG table.

Reset Type 2: Remote Temperature Reset

Reset Type 2 is an automatic water temperature reset based on a remote temperature sensor input signal. This function can be accessed by setting the following configurations:

1. Configure the remote temperature at which no reset occurs (*Remote temp* → *NO RESET*).
2. Configure the remote temperature at which full reset occurs (*Remote temp* → *FULL RESET*).
3. Enter the amount of reset (Deg Reset Water DT Full).

Reset Type 3: Controlled Water Temp Delta Reset

Reset Type 3 is an automatic controlled water temperature reset based on heat exchanger temperature difference. This function can be accessed by setting the following configurations:

1. Configure the controlled water temperature delta T at which no reset occurs (*Controlled Water DELTA T* → *NO RESET*).
2. Configure the controlled water temperature delta T at which full reset occurs (*Controlled Water DELTA T* → *FULL RESET*).
3. Enter the amount of reset (Deg Reset Water DT Full).

CAPACITY CONTROL

Capacity control provides chilled or condenser water temperature control by modulating the position of the inlet guide vane 1, and VFD speed for variable speed compressors.

If VFD OPTION is set to VFD and increased capacity is needed, the control will first try to increase IGV TARGET POSITION if it has not reached the travel limit; if the travel limit has been reached, the control increases VFD TARGET SPEED. If decreased capacity is needed, the control first tries to decrease VFD TARGET SPEED if it has not reached the minimum VFD speed; if the minimum VFD speed has been reached, the control decreases IGV TARGET POSITION instead. See Fig. 40.

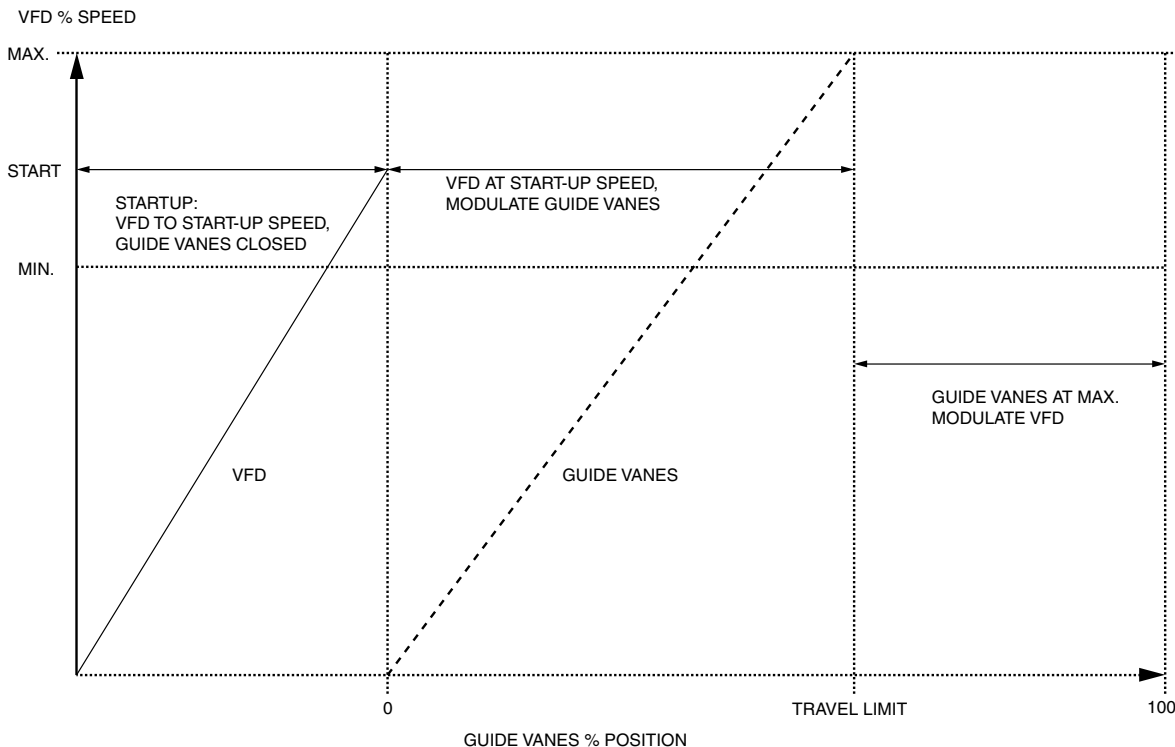

Fig. 40 — Guide Vane Position and VFD Speed

From the compressor relay closed point to the end of ramp loading, the VFD TARGET SPEED is the configured VFD start-up speed. When the chiller is running normally, the capacity control determines whether and how much to change VFD TARGET SPEED. When the chiller is in the shut-down process, VFD TARGET SPEED will be the minimum VFD speed.

NOTE: If the VFD option is set to NO VFD, or the compressor relay is not closed, VFD TARGET SPEED will be 0.

The guide vane position is determined by the Capacity Control function under normal conditions and other functions in abnormal conditions, which include capacity inhibit request or capacity decrease request. The guide vane actuator is driven by comparing the guide vane target position and the actual position. Guide vane position is limited to a value between zero and IGV Travel Limit, which is configured from the Service Configuration menu. When the chiller is shutting down or off, the guide vane is always driven to zero during normal shutdown.

RAMP LOADING

The ramp loading control slows the rate at which the compressor loads up. This control can prevent the compressor from loading up during the short period of time when the chiller is started and the chilled water loop has to be brought down to CONTROL POINT (Setpoint Table). Ramp loading helps reduce electrical demand charges by slowly bringing the chilled water to CONTROL POINT. The total power draw during this period remains almost unchanged. If the power outage lasts for more than 3 hours, then Temperature Ramp Loading will be used regardless of user configuration and the minimum loading rate (1°F/min) will be used.

Two methods of ramp loading are available: temperature ramp loading and motor load ramp loading.

Temperature Ramp Loading

Temperature ramp loading limits the rate at which the controlled water temperature decreases for cooling and increases for heating during ramping by reducing on cooling mode or increasing in heating mode the Temp Ramp per Min (**Configuration Menu** → **Service Parameters**) at the configured rate, until the pulldown set point is less than the cooling mode control point or greater than the heating mode control point. The Pulldown Ramp Type (**Configuration Menu** → **General Configuration**) is configured to 0 for temperature ramp loading.

Motor Load Ramp Loading

Motor load ramp loading limits the rate at which either the load current percentage or motor kilowatt percentage increases by incrementing the ramp demand limit at the configured rate. The PULLDOWN RAMP TYPE (**Configuration Menu** → **General Configuration**) is configured to 1 for motor load ramp loading.

If DEMAND LIMIT SOURCE (**Configuration Menu** → **General Configuration**) is set to AMPS, then PERCENT LOAD CURRENT is used for motor load ramp loading. If DEMAND LIMIT SOURCE is set to kW, then MOTOR PERCENT KILOWATTS is used for motor load ramp loading.

The rate of either Amps or KW Ramp per Min is configured at **Configuration Menu** → **Service Parameters**. The motor load ramp loading algorithm shall be deactivated when the Ramp Demand Limit is greater than or equal to the ACTIVE DEMAND LIMIT (General Parameters). It is also deactivated when Ramp Demand Limit is greater than or equal to 80%. There will be a one-minute delay for the compressor to be uploaded to target load (ramping load target 80% or ACTIVE DEMAND LIMIT if less than 80%) after ramping load demand limit is set to 80% (or ACTIVE DEMAND LIMIT if less than 80%).

SURGE CORRECTION CONTROL

There are two stages for surge correction: envelop control (surge prevention) and surge protection.

Envelop Control

A surge condition occurs when the lift becomes so high that the gas flow across the impeller reverses. This condition can eventually cause compressor damage. The surge prevention algorithm notifies the operator that chiller operating conditions are marginal and to take action, such as lowering entering condenser water temperature, to help prevent compressor damage.

If a high sound condition occurs at low guide vane position, the EC/HGBP valve is used to decrease the sound level. The envelop control algorithm is an operator-configurable feature that can determine if lift conditions are too high for the compressor and then take corrective action. High efficiency mode or low noise mode can be selected. Lift is defined as the difference between the saturated temperature at the impeller eye and at the impeller discharge. The maximum lift a particular impeller wheel can perform varies with the gas flow across the impeller and the size of the wheel.

If Actual Lift is higher than reference lift, a capacity inhibit signal will be sent. If Actual Lift is higher than reference lift plus Surge Line Upper Deadband, a capacity decrease signal will be sent. If Actual Lift is lower than reference lift minus Surge Line Lower Deadband, these 2 signals will be canceled. Capacity Control will respond to these 2 signals and make correction on IGV1 TARGET POSITION, VFD TARGET SPEED, and EC/HGBP actuator. To improve system performance SURGE PROFILE OFFSET will be incremented by 1 if no surge prevention has been active in the past 5 minutes. The Reference Lift will subtract the SURGE PROFILE OFFSET prior to comparing to Actual Lift. Note that this feature is disabled when Surge Profile Offset = 0.0 (Surge Correction Config Menu).

Surge Protection

The Surge Protection algorithm will run after SURGE DELAY TIME has elapsed when compressor has been commanded to turn on. It compares the present PERCENT LOAD CURRENT value with the previous value once every second. If the difference exceeds the maximum AMPS change value (SURGE DELTA % AMPS + [PERCENT LINE CURRENT / 10]), an incidence of surge has occurred, and the surge protection signal will be sent.

When an incidence of surge determined in this manner has occurred, the SURGE COUNTS will be incremented by one. On receiving the surge protection signal, Capacity Control will make corrections on IGV1 TARGET POSITION, VFD TARGET SPEED, and EC/HGBP actuator. When correction is in effect, Surge Protection Count will increase by 1 when a command for either IGV decrease, VFD speed increase, or EC/HGBP actuator activation is required for correction. Guide vane movement will be inhibited for 1 minute after surge protection ends.

Chiller will do 259 Alarm shutdown under the following conditions:

- If Surge Protection Counts exceed 20 within a Surge Time Period. Note that if VFD, then VFD target speed must equal max before this alarm is activated.
- If IGV, VFD, and HGBP cannot be further adjusted for surge protection when Surge Protection Counts exceed 4 within a Surge Time Period.

If IGV, VFD, and HGBP control cannot correct the problem, the chiller will initiate a shutdown alarm when the surge count is greater than 4.

ENVELOP/HOT GAS BYPASS (HGBP) CONTROL

This function is used to artificially load the chiller and keep it running under low load conditions or to prevent surge conditions. Since this also reduces the performance of the machine, EC/HGBP Control is a user-selectable option.

PIC 6 supports 3 different types of EC/HGBP control valve types:

1. Continuous; modulating valve controlled by two contactors, one to open and another to close. If both contactors are open the valve will hold its position. Valve has a feedback signal for fully open/closed position (not used in North America products).
2. On/off; valve controlled by one contact. It has no position feedback and is unable to hold its current position.
3. mA; valve controlled by 4 to 20 mA signal. The type can be configured in the Option Configuration menu.

Envelop/hot gas bypass operation has three different modes when installed (hgbp_opt > 0) and enabled (hgbp_sel > 0):

- Envelop control and surge protection — Each compressor has unique lift characteristics that can be plotted to determine performance. The controller will determine operating conditions that could result in compressor surge and activate the bypass valve to prevent surge until the chiller operating parameters are in a safe area on the curve where the valve may be closed again. For surge prevention, the valve will be commanded to open when surge prevention is high, was active, or is too close when there is no surge. The valve shall be on hold if the compressor is in the surge line deadband. For surge protection, the envelope control valve will be commanded to open when the surge count is greater than allowed and will be commanded to close when surge protection action is completed.
- Envelop (HGBP) low load operation — In this condition, the valve will be opened to prevent a recycle shutdown from occurring. The valve will remain open until this minimal loading condition has passed and there is no surge condition present. For low load operation, the valve activates based on the IGV position and the controlled water temperature. The EC valve is set to Open when IGV position is less than the configured ECV Open IGV1 Position. It is set to (cooling mode) when the controlled water temperature is less than or equal to the control point minus “ECV Low Load DB”. The EC valve is set to Close when IGV position is greater than the ECV Close IGV1 Position. It is set to (cooling mode) when the controlled water temperature is greater than the control point plus “ECV Low Load DB”.
- Combination for envelop control and surge correction, as well as low load operation — When this option is selected, both EC for envelop control/surge protection and EC for low load operation will be performed. Surge protection will take higher priority if both conditions are satisfied.

ECONOMIZER DAMPER VALVE CONTROL

The economizer maintains the difference between evaporator pressure and economizer pressure. Economizer pressure should always be higher than evaporator pressure.

When the chiller is initially powered on, or when the compressor shuts down, the damper valve will be commanded to close. These and other conditions are shown in Table 18.

Table 18 — Economizer Damper Valve Status

SYSTEM CONDITION	ECONOMIZER DAMPER VALVE STATUS
Chiller initially powered on	Fully closed
Compressor shut down	Fully closed
During damper valve action delay	Fully closed
Economizer pressure > evaporator pressure + Damper valve open DB	Open
Economizer pressure < evaporator pressure + Damper valve close DB	Closed
All other conditions	Current position maintained

If the damper valve has been commanded to open for a continuous 5 minutes, and the Damper Valve Full Opened condition is still not TRUE, the control system generates an alert 154. Similarly, if the damper valve has been commanded to close for a continuous 5 minutes, and the Damper Valve Full Closed condition is still not TRUE, the control system generates an alert 154.

If the compressor is running and if economizer pressure becomes less than or equal to evaporator pressure, an alarm 268 will be tripped and compressor will be shut down.

DEMAND LIMIT

The PIC 6 controls provide a feature for limiting AVERAGE LOAD CURRENT or MOTOR KILOWATTS by limiting capacity via guide vane control/VFD control. The limit may be applied in two ways. The first is called ACTIVE DEMAND LIMIT, which is equal to a BASE DEMAND LIMIT value (set in the SETPOINT screen, default value 100%). ACTIVE DEMAND LIMIT may also be forced to be different from BASE DEMAND LIMIT by manually overriding (forcing) the value via a CCN network device. If the DEMAND LIMIT SOURCE exceeds the ACTIVE DEMAND LIMIT by 5% or less, capacity will be inhibited. If the DEMAND LIMIT SOURCE exceeds the ACTIVE DEMAND LIMIT by more than 5%, capacity will be decreased.

Alternatively, the limit may be applied by AUTO DEMAND LIMIT INPUT, an optional 4 to 20 mA input. This demand limit control option (4 to 20 mA DEMAND LIMIT TYPE) is externally controlled by a 4 to 20 mA signal. The option is set up on the **Configuration Menu → General** screen. When enabled, 4 mA will set ACTIVE DEMAND LIMIT to 100% of the DEMAND LIMIT SOURCE (regardless of the value of BASE DEMAND LIMIT), and 20 mA will set ACTIVE DEMAND LIMIT to the value configured for DEMAND LIMIT AT 20 mA in the **Configuration Menu → SERVICE PARAMETERS** screen.

OVERRIDE CONTROL

Capacity overrides can prevent some safety shutdowns caused by exceeding the motor amperage limit, evaporator refrigerant low temperature safety limit, motor high temperature safety limit, and condenser high pressure limit. In these cases there are two stages of capacity control:

1. When the value of interest crosses the first stage set point into the override region, the capacity is prevented from increasing further, and the status line on the PIC 6 controller indicates the reason for the override. Normal capacity control operation is restored when the value crosses back over the first stage set point, leaving the override region.
2. When the value of interest is in the override region and further crosses the second stage set point, the capacity is decreased until the value meets the override termination condition. The PIC 6 controls resume normal capacity control operation after the override termination condition has been satisfied. (In the case of high discharge superheat, there is an intermediate stage.)

Table 19 summarizes these override parameters.

Table 19 — Override Parameters

VERRIDE CONDITION	VERRIDE PARAMETER	FIRST STAGE CAPACITY INHIBIT	DEFAULT VALUE/ CONFIGURABLE RANGE	SECOND STAGE CAPACITY DECREASE	VERRIDE TERMINATION
High condenser pressure override (Unit Type Heat/Cool=1 in Configuration Menu → Factory Parameters. Before configuring Unit Type = 1 the condenser shell side must be verified to be 300 psig design or higher.)	CONDENSER PRESSURE	> COND PRESS OVERRIDE HIGH	250 psig/200-260 psig	> COND PRESS OVERRIDE HIGH + 2.4 psi	< COND PRESS OVERRIDE HIGH — 1 psi
High condenser pressure override (Unit Type Cool Only = 0 in Configuration Menu → Factory Parameters. This corresponds to a condenser with standard 185 psig design pressure.)	CONDENSER PRESSURE	> COND PRESS OVERRIDE LOW	140 psig/90-170 psig	> COND PRESS OVERRIDE LOW + 2.4 psi	< COND PRESS OVERRIDE LOW — 1 psi
Low evaporator temperature override	CALC EVAP SAT TEMP or EVAP REFRIG LIQUID TEMP	< EVAP SAT OVERRIDE TEMP (EVAP SAT OVERRIDE TEMP = EVAP TRIPPOINT + EVAP OVERRIDE DELTA T)		< EVAP SAT OVERRIDE TEMP - 1°F (0.56°C)	> EVAP SAT OVERRIDE TEMP + 2°F (1.1°C)
High motor temperature override	COMP MOTOR WINDING TEMP	> COMP MOTOR TEMP OVERRIDE	200°F/150 to 200°F (93.3°C/65.6 to 93.3°C)	COMP MOTOR WINDING TEMP > COMP MOTOR TEMP OVERRIDE + 10°F (5.6°C)	COMP MOTOR WINDING TEMP < COMP MOTOR TEMP OVERRIDE — 2°F (1.1°C)
High current override	PERCENT LINE CURRENT	PERCENT LINE CURRENT > 100%		PERCENT LINE CURRENT > 105%; 102% WHEN 32VS VFD INSTALLED	PERCENT LINE CURRENT <= 100%
Low discharge superheat override	Discharge Superheat (DSH)	< DSH REQUIRED + 1		< DSH REQUIRED — 3	> DSH REQUIRED + 2
Low source temperature protection override	Leaving water temperature (heating mode)	< LWT PROTECTION SETPOINT — 2°F (1.1°C)			>LWT PROTECTION SETPOINT + 0.5°F (0.3°C)

Other types of override events do not override control guide vane or VFD operation, but are reported:

- High compressor discharge temperature override — For compressor/frame 6 and 7, if the COMP DISCHARGE TEMP is greater than the COMP DISCHARGE ALERT threshold, then high discharge temperature override will be displayed in the main screen until the COMP DISCHARGE TEMP is less than the COMP DISCHARGE ALERT threshold — 2°F (1.1°C).
- High compressor bearing temperature override — For compressor/frame 6 and 7, if one of the compressor bearing temperatures is greater than the compressor bearing temperature Alert (*Configuration Menu → Protective Limit*) threshold, then High Bearing Temp Override will be active until all of the compressor bearing temperatures are less than Comp Bearing Temp Alert minus 2°F (1.1°C). For compressors 2-5, C, and E, if the calculated compressor bearing temperature is greater than the bearing temperature alert threshold, then high bearing temperature override will be active until calculated bearing temperature is less than threshold minus 2°F (1.1°C).
- Low Discharge Superheat Temperature Override — This override is ignored during the first 5 minutes after chiller start-up. There are additional requirements for normal override function after start-up. For compressor E, condenser pressure must be 10 psi greater than cooler pressure; for compressor/frame 6 and 7, the damper must have been open for 20 consecutive seconds.

RECYCLE CONTROL

The chiller may cycle off and wait until the load increases to restart when the compressor is running in a lightly loaded condition. This normal cycling is known as “recycle.”

In cooling mode, a recycle shutdown is initiated when either of the following conditions is true:

- Leaving chilled water temperature (or entering chilled water temperature, if the EWT CONTROL OPTION is enabled) is more than 5°F (2.8°C) below the CONTROL POINT.
- Leaving chilled water temperature (or entering chilled water temperature, if the EWT CONTROL OPTION is enabled) is below the CONTROL POINT, and the chilled water temperature difference is less than the RECYCLE SHUTDOWN DELTA T.

In heating mode, a recycle cycle shutdown occurs when either of the following conditions is true:

- Leaving condenser water temperature (or entering condenser water temperature, if the EWT CONTROL OPTION is enabled) is more than 5°F (2.8°C) below the CONTROL POINT.
- Leaving condenser water temperature (or entering condenser water temperature, if the EWT CONTROL OPTION is enabled) is above the CONTROL POINT, and the condenser water temperature difference is less than the RECYCLE SHUTDOWN DELTA T.

NOTE: Recycle shutdown will not occur if the CONTROL POINT has been changed by more than 1°F (0.56°C) within the previous 5 minutes of operation.

When the chiller is in RECYCLE mode, the chilled water pump relay remains energized so the chilled water temperature can be monitored for increasing load. The recycle control uses RECYCLE RESTART DELTA T to check when the compressor should be restarted. In cooling mode, the compressor will restart when the leaving chilled water temperature (or entering chilled water temperature, if the EWT CONTROL OPTION is enabled) is greater than the CONTROL POINT plus the RECYCLE RESTART

DELTA T for 5 consecutive seconds. In heating mode, the compressor will restart when the leaving condenser water temperature (or entering condenser water temperature, if the EWT CONTROL OPTION is enabled) is less than the CONTROL POINT minus the RECYCLE RESTART DELTA T for 5 consecutive seconds.

RUNNING TIMERS AND COUNTERS

The PIC 6 control maintains two run-time clocks: COMPRESSOR ONTIME and SERVICE ONTIME. COMPRESSOR ONTIME indicates the total lifetime compressor run hours. SERVICE ONTIME is a resettable timer that can be used to indicate the hours since the last service visit or any other event. A separate counter tallies compressor starts as TOTAL COMPRESSOR STARTS. All of these can be viewed on the RUN TIMES screen. Both Ontime counters roll over to 0 at 500,000 hours. Manual changes to SERVICE ONTIME from the screen are permitted at any time. If the controller is replaced, one opportunity before the first start-up with the new controller is provided to set COMPRESSOR ONTIME and TOTAL COMPRESSOR STARTS to the last readings retained with the prior controller.

The chiller also maintains a start-to-start timer and a stop-to-start timer. These timers limit how soon the chiller can be started and are displayed on the system overview (home) and RUN TIMES screens. They can be configured in the **Configuration Menu** → **GENERAL CONFIGURATION** screen. They must expire before the chiller starts. If the timers have not expired, the RUN STATUS parameter on the System Overview (Home) and GENERAL PARAMETERS screen reads TIMEOUT.

WATER PUMPS CONTROL (FREEZE PREVENTION)

Evaporator Freeze Prevention

When the evaporator saturated refrigerant temperature or evaporator refrigerant temperature is less than the EVAP REFRIG TRIPPOINT + REFRIG OVERRIDE DELTA T (configurable from 2°F to 5°F (1.1°C to 2.8°C) in the **Configuration Menu** → **Protective Limit screen**), an OVERRIDE—LOW EVAP REFRIG TEMP event will occur.

For any running status, if either of the conditions below is true then unit will shut down under Alarm PROTECTIVE LIMIT - EVAPORATOR FREEZE (State 261):

- Evaporator saturated refrigerant temperature or evaporator refrigerant temperature is equal to or less than the EVAP REFRIG TRIPPOINT (33°F [0.6°C] for water, (configurable for brine in **Configuration Menu** → **Protective Limit screen**) plus 1°F (0.56°C).
- Leaving chilled water temperature or entering chilled water temperature is less than EVAP REFRIG TRIPPOINT plus 1°F (0.56°C).

NOTE: If the chiller is in recycle mode, it will transition to TRIPOUT, and the CHILLED WATER PUMP will remain on.

The alarm will be clearable when the evaporator saturated refrigerant temperature, evaporator refrigerant temperature, leaving chilled water temperature, and entering chilled water temperature rise 5°F (2.8°C) above the EVAP REFRIG TRIPPOINT.

Condenser Pump Control

The chiller will monitor the condenser pressure and may turn on the condenser pump. If the condenser pressure is greater than or equal to the COND PRESS OVERRIDE, and the entering condenser water temperature is less than 115°F (46.1°C), the condenser pump will energize to try to decrease the pressure and Process Alert - High Condenser Pressure Chiller Off (Alert 157) will be generated. The pump will turn off when the condenser pressure is 3.5 psi (24.1 kPa) less than the pressure override and the condenser refrigerant temperature is less than or equal to the entering condenser water temperature plus 3°F (1.7°C).

NOTE: COND PRESS OVERRIDE is found in the **Configuration Menu** → **Protective Limit screen**.

Condenser Freeze Prevention

This control helps prevent condenser tube freezing by energizing the condenser pump relay. The PIC 6 module controls the pump and, by starting it, helps to prevent the water in the condenser from freezing.

When the chiller is off and condenser saturated refrigerant temperature is less than or equal to the condenser freeze point, the condenser water pump will be energized (Alarm State 262, PROTECTIVE LIMIT - CONDENSER FREEZE). The fault state will clear and the pump will turn off when the condenser saturated refrigerant temperature is more than 5°F (2.7°C) above the condenser freeze point and the entering condenser water temperature is greater than the condenser freeze point. If the chiller is in recycle shutdown mode when the condition occurs, the controls will transition to a non-recycle shutdown.

CONTROL TEST

This feature allows the operator to quick-test the controls and related hardware, including all unit-controlled outputs except compressor output. Test of components with position feedback requires calibration in Quick Calibration prior to control test.

The compressor must be off to run the test function. If the unit is on, the test function cannot be accessed. The compressor can only be started after the control test is finished. The test function also requires the user to enter the User password if it has not already been entered. All control test parameters are accessible through the Quick Test table. To perform the control test function, set the first item Quick Test Enable in the Quick Test table to Enable.

Unless otherwise noted, all protective limits remain active during the controls test.

Discrete Outputs

When the control test is enabled, discrete outputs can be enabled using the Quick Test table. Discrete valves that can be tested in Quick test are: GV1 Open, GV1 Close, Oil Pump Relay, HGBP Open, HGBP Close, Damper Open, Damper Close, Condenser Pump Relay, Evaporator Pump Relay, Alarm Relay, and Alert Relay.

NOTE: The following outputs cannot be enabled at the same time Guide Vane Increase and Guide Vane Decrease are enabled: EC/HGBP Valve Open and EC/HGBP Valve Close; Economizer Damper Valve Open and Economizer Damper Valve Close.

NOTE: For oil pressure, a value ≥ 18 psi within 40 seconds after the oil pump is turned on indicates a confirmation of pressure (Oil Pres Test Passed=YES).

Analog Output

When the control test is enabled, the following analog outputs can be enabled by entering the positions in the QCK_TST table:

- Head Pressure Valve
- Diffuser Actuator
- Oil EXV (electronic expansion valve)
- Chiller Status Output (Q_CHST)

Guide Vane Calibration

The guide vane position should be calibrated before starting the chiller. Guide vane calibration can be started by setting Quick Test Enable to Enable and GV1 Calibration Enable to Enable in the Quick Calibration menu.

If the actuator type is digital 0, then:

- The fully closed guide vane feedback resistance will be in the range of 62.5 ohms to 688 ohms (350 ± 75 ohms target setting).
- The fully opened guide vane feedback resistance will be in the range of 6190 ohms to 11,496 ohms (10,000 ohms target setting).

If the actuator type is analog (1):

- The fully closed guide vane feedback mA value will be in the range of 3 mA to 5 mA.
- The fully opened guide vane feedback mA value will be in the range of 19 mA to 20.8 mA.

AUTO RESTART

The Auto Restart option can be enabled from the Configuration Menu or Option Menu. This feature allows the chiller to automatically start up if the chiller was shut down due to a power loss condition once the power has been returned to normal conditions.

SWIFT RESTART (CAPACITY RECOVERY™)

This function is designed for data center or other applications. It allows the chiller to be restarted quickly to meet building load requirements.

To enable this function, the SWIFT RESTART OPTION point in the CONF_OPT table (*Configuration Menu → Option*) should be set to ENABLE.

The water flow verification time, oil prelube time and other delays will be decreased compared to a normal start-up.

COOLING TOWER CONTROL

If WATER PRESSURE OPTION in the CONF_OPT table is set to 1 or 2, there will be another optional hydraulic control I/O board in the PIC 6 control system to allow PIC 6 control for the water pumps and cooling tower fans (high speed and low speed).

The cooling tower fans are controlled by the pressure difference between condenser and evaporator and entering water temperature of condenser. The objective is to maintain the entering condenser water temperature in the optimal range.

HEAD PRESSURE CONTROL

If the chiller system is equipped with a head pressure control valve or other device to modulate the condenser water flow, and the HEAD PRESSURE VALVE option in the CONF_OPT table is ENABLED, the PIC 6 control system will control the opening of the head pressure valve to maintain the pressure difference between condenser and evaporator. The output of this valve is 4 to 20 mA type.

Before using this function, the pressure difference values for 20 mA and 4 mA should be set. The head pressure valve should be in fully closed position when chiller is in OFF mode. For the head pressure control to function properly it is suggested to set the HPR Vlv Deadband to 0.5 psig or less.

ICE BUILD OPTION

The PIC 6 controller provides an ice build option based on efficiency improving point. The ICE BUILD OPTION in the CONF_OPT table should be set to ENABLED to make ice build active, and the following two parameters should be configured:

- Ice_recy (ICE BUILD RECYCLE) indicates whether recycle option is enabled in ice build mode.
- Ice_term (ICE BUILD TERMIN SOURCE) indicates how the ice build is terminated. There are three types: temperature (0), dry contact (1), or combined temperature and dry contact (2).

TIME SCHEDULE

The PIC 6 control provides three schedules:

- Local schedule
- Ice build schedule
- Network schedule

Each schedule has 8 time segments. If two time segments overlap, the unoccupied time segment takes priority.

There are 16 holiday time segments. Each holiday time segment is determined by three parameters—month, start date,

and holiday days. The controller will be in unoccupied mode when a holiday time segment is active. PIC 6 includes a Day-light Savings Time function. Use Broadcast Menu to enable this feature and configure start and end dates.

BLACK BOX

The black box task continuously stores parameters in memory every 5 seconds. Reporting of a chiller operation alarm triggers the controller to generate a collection of data records. Each collection contains up to 180 records that consist of 168 records (corresponding to 14 min.) before the alarm and 12 records (corresponding to 1 min.) after the alarm. Each record is associated with a time stamp. Files are saved as csv files; up to 20 files can be stored.

The black box file can be uploaded with the Carrier Service Tool. Once the upload is done, the original files are automatically deleted.

PRESSURE TRANSDUCER CALIBRATION

The HMI pressure readings are displayed in the *Main Menu → Pressures screen*. See Fig. 41.

Component	Reading	Unit
Evaporator Pressure	-10.0	PSIG
Condenser Pressure	-10.0	PSIG
Economizer Pressure	0.0	PSIG
Oil Supply Pressure	-10.0	PSIG
Oil Sump Pressure	-10.0	PSIG
Oil Pump Delta P	0.0	PSI
Oil/Ref Delta P Offset	0.0 ✓	PSI
Head Pressure Reference	0.0	PSI

Fig. 41 — Pressures Screen, Page 1

Once a year the pressure transducers should be checked against a pressure gage. Attach a set of accurate refrigeration gages to the transducer being checked and compare the two readings. If there is a difference the transducer can be calibrated as described below (the Oil Pump Delta P reading should be zero when the compressor is off). Calibration requires Service level access to the HMI.

NOTE: It is usually not necessary to calibrate at initial start-up unless chiller is at high altitude.

1. Go to *Main Menu → Maintenance Menu → Pressure Sensor Calib*. See Fig. 42 and 43.

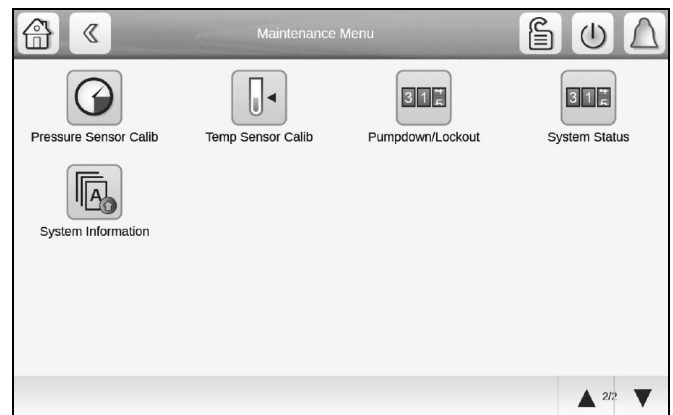

Fig. 42 — Pressure Sensor Calib Screen, Page 1

2. Each transducer is supplied with 5 vdc from the IOB. Calibration is done by selecting the appropriate Pressure Sensor option on the Pressure Sensor Calib screen. The screen

for the selected option is displayed. Figure 43 shows the Evap Pressure Sensor screen (PRSCAL01 as an example).

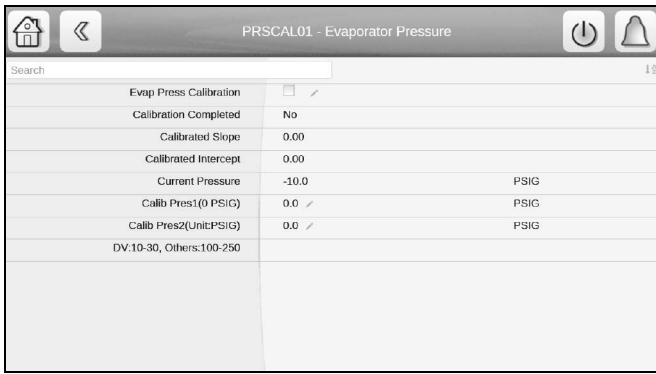

Fig. 43 — Evap Pressure Sensor Screen

- Set Calibration Enable to Enable. Calibration for this sensor is complete and the new slope and intercept will be used for the calibrated transducer in the pressure or temperature tables.
- With the transducer at atmospheric pressure (zero gage pressure), ensure that “Calib Press1 (0 PSI)” = 0 PSIG.
- Pressurize the transducer to a known pressure between 100 and 250 psig, and enter that pressure as read from calibrated gage in the “Calib Press2 (100-250 PSI)” field and press “OK.”
- Screen will show “Calibration Completed = Yes” upon successful calibration. To exit, use the arrow key or click the Home button.

TEMPERATURE SENSOR CALIBRATION

The four water temperature sensors can be separately calibrated to have their temperature readings offset by a specified amount. Follow these steps for each sensor:

- Go to **Main Menu → Maintenance Menu → Temp Sensor Calib**. See Fig. 42.
- Place the temperature sensor in a 32°F (0°C) water solution.
- Read the sensor raw temperature on the Maintenance screen.
- Calculate the offset to be applied as follows:
 $32 - \text{sensor raw temp (°F)}$
 Example:
 ECW sensor raw temperature reads 32.6°F.
 ECW temperature offset must be set to -0.6°F
 $(32 - 32.6 = -0.6)$
- In the Temp Sensor Calib screen, enter the temperature offset for the appropriate sensor as calculated in Step 4. See Fig. 44. NOTE: The offset cannot exceed ± 2°F (1.1°C).



Fig. 44 — Temp Sensor Calib Screen, Page 1

- Verify that the measured temperature value is the same as the controlled temperature.

ISM VFD INPUT/OUTPUT CALIBRATION

For VFD units with ISM (option), Target Speed Output (J8-1,2) and VFD Speed Feedback (J6-1,2) must be calibrated as part of commissioning the variable frequency drive. Before performing the calibration, be sure that VFD Option = 1 (FS FVD) (**Main Menu → Configuration Menu → Factory Parameters**) and that the controller has been connected to the ISM board. Objective is to have target speed match actual VFD speed within 5% or better at 70 to 100% speed. Note that it is possible for all calibration to be done at the drive. J8B must be used to provide the drive with a signal.

Calibrating J8B 4-20mA Output (to VFD)

- Go to **Main Menu → Maintenance Menu → ISM Calibration**. See Fig. 45.



Fig. 45 — ISM Calibration Screen

- Select J8B 4-20mA Output. The ISM_CAL1 screen is displayed. See Fig. 46.

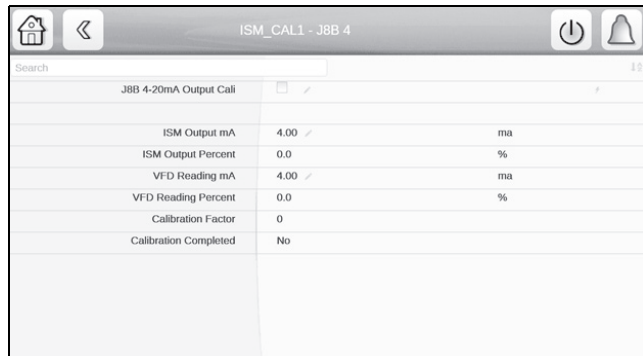

Fig. 46 — ISM_CAL1 Screen

- Set Calibration Enable to Enable.
- Input a test output mA value. The controller will make the ISM output this mA value upon exiting the menu using the back arrow key. See Table 20 for corresponding mA and frequency signals. Verify/calibrate Target and Actual VFD speed at 70 to 100%. Have start-up engineer calibrate input to ISM 2M Aux to close at Target Speed 58%.
- If required, input the actual reading of mA value from VFD or mA meter.
- PIC 6 will calculate the calibration factor as follows:
 $\text{Calibration Factor} = 1000 * (\text{Actual Reading mA} - \text{Output mA})$
 Range: 0 to 2000

Table 20 — Corresponding mA and Frequency Signals

SIGNAL 4-20 mA	FREQ 50 Hz	FREQ 50 Hz	TARGET SPEED %
(13.2)	(28.8)	(34.5)	(58)
14.4	32.5	39.0	65.0
15.2	35.0	42.0	70.0
16.8	40.0	48.0	80.0
18.4	45.0	54.0	90.0
20.0	50.0	60.0	100.0

NOTE: Parentheses indicate testing only with no motor running.

Calibrating J6 0-10V or 0-5V (as configured) Input (from VFD)

1. When the chiller is running, record the VFD feedback voltage and the actual reading on the ISM. Note that it is possible that calibration is only required at the drive.
2. Shut down the chiller.
3. Go to *Main Menu* → *Maintenance Menu* → *ISM Calibration*.
4. Select J6 0-10V Input. The ISM_CAL2 screen is displayed. See Fig. 47.

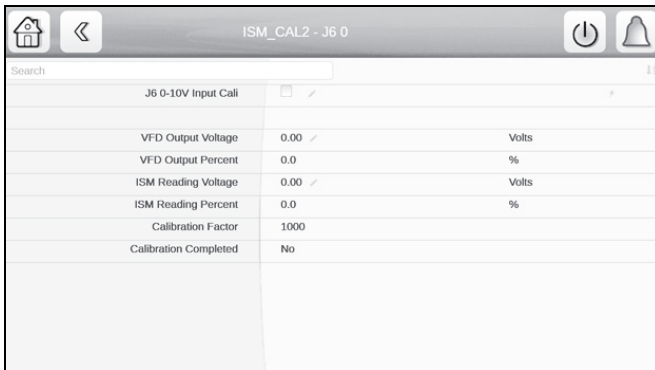

Fig. 47 — ISM_CAL2 Screen

5. Set Calibration Enable to Enable.
6. Input the VFD feedback voltage.
7. Input the actual ISM reading.
8. PIC 6 will calculate the calibration factor as follows:

$$\text{Calibration Factor} = 1000 * (\text{VFD feedback voltage} / \text{ISM actual reading voltage})$$
 Range: 800 to 1200
9. Verify that the PIC control exits calibration mode.

ALARM EMAIL

The alarm email function sends automatic email messages to specified service personnel for remote maintenance purposes. This function can be set up from *Main Menu* → *System Configuration* → *E-Mail*. Subsequently if there is an alarm the function will send an e-mail message. Another message is sent when all alarms return to normal. See Fig. 48 and 49.

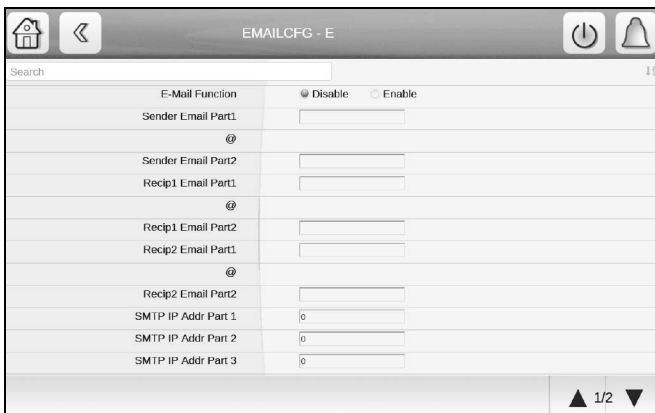

Fig. 48 — E-Mail Configuration Screen, Page 1

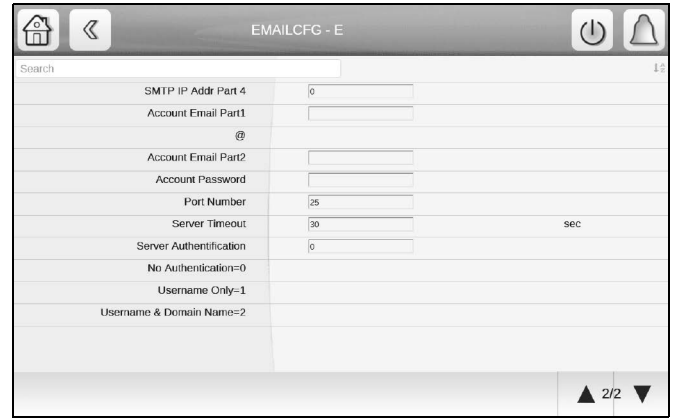

Fig. 49 — E-Mail Configuration Screen, Page 2

The alarm task runs periodically. At each alarm task run time, the status change of each alarm is checked and one email message is sent to each specified recipient when one or more alarms are switched on. When all alarms return to normal, another e-mail message is sent to remote maintenance service personnel.

The e-mail message provides the unit description and location stored in the Control Identification table, available from the CONFIGURATION menu. See Fig. 50.

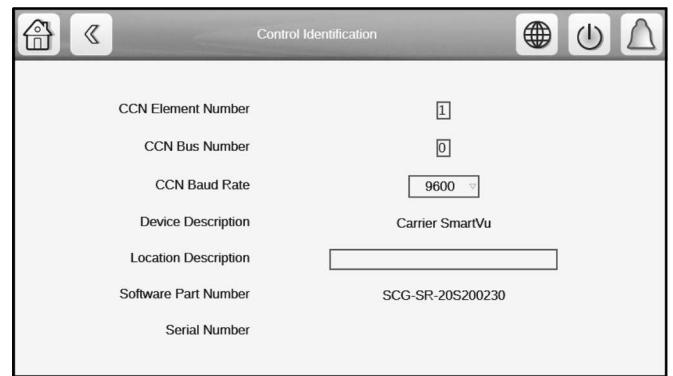

Fig. 50 — Control Identification Screen

PROGNOSTICS

This diagnostic and prognostic function is designed for service and to help resolve problems before they affect operating efficiency and chiller life. The CONF_PRG (Prognostics Config) screen is available from the Configuration Menu. See Fig. 51 and 52. The default of this feature is DSABLE.

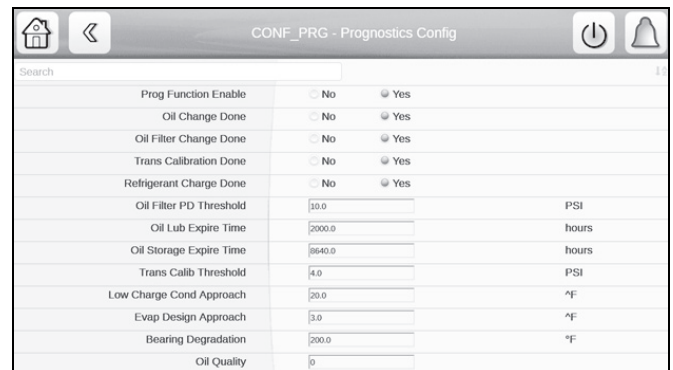

Fig. 51 — Prognostics Config Screen, Page 1

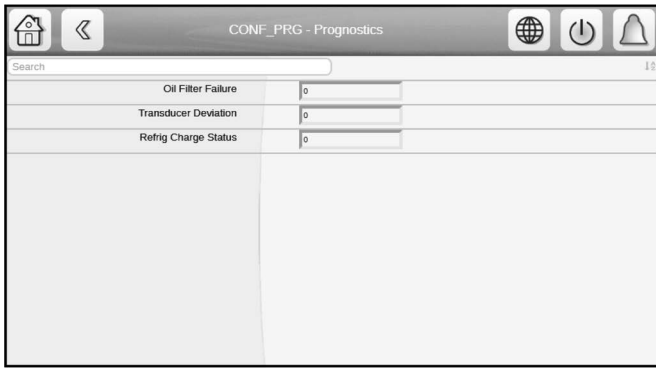

Fig. 52 — Prognostics Config Screen, Page 2

Oil Quality

The lubrication oil should be changed regularly to maintain the appropriate lubrication for the motor and compressor. On the Prognostics status screen, a green light is displayed for Oil Quality if the operating time is less than 90% of the configured oil change duration and total time (includes operation and non-operation) is less than 90% of the oil store duration.

A yellow light is displayed if the operating time is more than 90% of configured oil change duration or if total time (includes operation and non-operation) is more than 90% of the oil store duration.

A red light is displayed if the operating time is greater than configured oil change duration, or if total time (includes operation and non-operation) is more than oil store duration, and oil change is not completed.

When the light is red or yellow, the oil change completed flag is set to NO by the controller. After the oil has been changed, the oil change completed flag should be set to YES manually. The controller then changes the light to green.

Oil Filter

This alert function is active only in an oil pump control test. Two transducers, one located before the oil pump and the other located after the oil filter, are used to identify when the pressure differential has fallen below the alert threshold. If the oil pump is forced to ON and after 10 seconds, if the pressure differential is lower than the threshold set in the Oil Filter Pres Diff field, the filter needs to be replaced and the dedicated alert 160 is reported.

The Oil Filter light is updated in control test mode automatically and can be reset to green in all modes manually.

If the oil pump is forced to ON and, after 10 seconds, if the pressure differential is lower than the threshold, the Oil Filter red light is displayed on the Prognostics status screen.

If the oil pump is forced to ON and, after 10 seconds, if the pressure differential is between the threshold and the threshold plus 2 psig, the yellow light is displayed on the Prognostics status screen.

If oil pump is forced to ON and after 10 seconds, if the pressure differential is greater than the alert threshold plus 2 psig, the green light is displayed on the Prognostics status screen.

When the light is red or yellow, the Oil Filter Change Done flag is set to NO by the controller. After the oil filter is changed, the Oil Filter Change Done flag should be set to YES manually. The controller then changes the Oil Filter light to green.

Refrigerant Transducer Calibration

When the unit is offline for more than 5 minutes, a comparison is made among the evaporator, condenser, and economizer refrigerant pressure transducers. A difference of more than the configurable threshold set in the Trans Calib Threshold option generates an alert 161 that a calibration is required. The comparison is done for all of the transducers.

A value more than the configurable threshold displays the red light in for Refrigerant Transducer Calibration in the Prognostics status screen. A value more than 0.9 times the configurable threshold displays the yellow light in the Prognostics status screen. A value less than 0.9 times the configurable threshold displays the green light in the Prognostics status screen.

When the light is red or yellow, the Trans Calibration Done flag is set to NO by the controller. After transducer re-calibration, the Trans Calibration Done flag should be set to YES manually. The controller then changes the Refrigerant Transducer Calibration light to green.

Refrigerant Charge

This function uses the evaporator approach (Evap Design Approach) setting and compressor discharge temperature (Bearing Degradation) setting in relation to the condenser refrigerant temperature (Low Charge Cond Approach) setting to generate an alert 162 of possible low refrigerant charge and display the red light based on the following conditions:

- compressor is running but not in ramp loading status; and
- condenser approach is greater than 0.9 times the low refrigerant charge condenser approach threshold; and
- evaporator approach is 2°F (1.1°C) greater than design approach (ap_dgap)

The Refrigerant Charge yellow light is displayed under the following conditions:

- compressor is running but not in ramp loading status; and
- condenser approach is greater than low refrigerant charge condenser approach threshold (rch_cath); and
- evaporator approach is 1.8°F (1°C) greater than design approach (ap_dgap)

When the light is red or yellow, the Refrigerant Charge Done flag is set to NO by the controller. After the refrigerant charge is completed, the Refrigerant Charge Done flag should be set to YES manually. The controller then changes the Refrigerant Charge light to green.

MASTER SLAVE CONTROL

This control, available from page 2 of the Configuration Menu, provides the capability to operate 2 chillers in Master/Slave mode. The slave chiller should be set to NETWORK mode and controlled by the master chiller.

The two chillers can be configured to be in parallel or in series. When they are in series mode, the master chiller's evaporator must be downstream. The user can configure which condenser (master or slave) is downstream. The master chiller shall monitor all external commands such as start/stop, demand limiting, or setpoint configuration.

The master/slave function provides the ability to select a lead chiller from the master and the slave chillers. Selection is based on the delta between the master and the slave run hours, and tries to optimize the runtime hours. If this function is not set, the lead chiller is always the master chiller and should be changed to lag in case of failure.

The lead chiller shall always be started first, and the lag chiller shall be maintained at zero percent capacity. When the lead chiller cannot be loaded anymore, then the lag start timer is started. The lag chiller shall always be stopped prior to lead chiller.

If a communication failure is detected between the master and the slave chillers, all master/slave functions are disabled and chillers return to stand-alone operations until communication is reestablished. If middle sensor is installed, this, among other things, can be configured in the Master Slave Config table. Figures 53 and 54 show Master/Slave Config options.

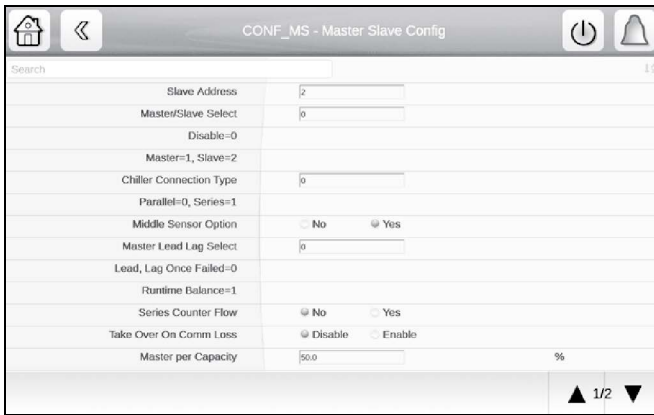

Fig. 53 — Master/Slave Config Screen, Page 1



Fig. 54 — Master/Slave Config Screen, Page 2

Oil EXV Option

If the chiller system is equipped with an Oil EXV control valve, and the Oil EXV valve option in CONF OPT table (Option Configuration in the Configuration Menu) is enabled, the PIC 6 control system will control the opening of the Oil EXV valve to maintain the oil supply temperature. The output of this valve is 4 to 20 mA. Before using this function, configure the Oil Temp High Threshold and Oil Temp Low Threshold options.

One minute after the compressor starts, if the oil supply temperature is higher than the Oil Temp High Threshold, the oil EXV valve should be in the fully opened position. If the oil supply temperature is lower than the Oil Temp Low Threshold, the oil EXV valve should be in the fully closed position. In all other cases, the oil EXV valve position will be calculated according to the oil supply temperature.

One minute after compressor shutdown is completed, the oil EXV valve should be in fully closed position.

Pumpdown/Lockout

The Pumpdown/Lockout feature prevents compressor start-up when there is no refrigerant in the chiller. To access this function one must be logged in as Advanced User/Service or higher. The feature can be accessed from the Maintenance Menu (not available in v2.3 software).

The Pumpdown/Lockout function provides precautions when an external pumpout unit is removing refrigerant from chiller. When the lockout is activated, the controller takes the following steps:

- Starts water pumps and confirm flows
- Monitors evaporator pressure, condenser pressure, and evaporator refrigerant temperature during pumpout procedures
- Turns pumps off after pumpdown
- Proceeds to lock out the compressor

The Terminate Lockout feature ends the Pumpdown/Lockout after refrigerant is added. Press End Lockout on the Pumpdown/Lockout menu in order to initiate the process, which proceeds as follows:

- Starts pumps and confirm flows
- Monitors evaporator pressure, condenser pressure, evaporator temperature during charging process
- Terminates compressor lockout

Displaying Data Trends

The PIC 6 control system offers the ability to configure and display color-coded system trends without a password. Select **Main Menu → Trending**.

On the Trending screen (see Fig. 55), check the data to be tracked, and set the beginning and end points for the selected data. To change a data color, select the colored square and choose a new color from the pop-up color bar. To view data trends, select the down arrow at the bottom right of the Trendings screen. The next page displays the selected data in the chosen colors. See Fig. 56.



Fig. 55 — Trending Screen Set-Up Page



Fig. 56 — Trending Screen Display Page

Hydraulic Option

WATER FLOW MEASUREMENT

PIC 6 Controller provides the function of measuring water flow rate.

Equipped with a field installed flow meter, it can compute the water flow rate from the input signal sent from the evaporator/condenser water flow sensor (4 to 20 mA) to the IOB (see product specific IOB4 wiring schematic).

1. In **Configuration Menu** → **Option 2**, set **IOB4 Option** = 4.
2. Change **Water Flow Measurement** from **0=No** to **1=WTR Flow MTR**. This will unhide the fields **Water Flow at 4mA = _____ GPM** and **Water Flow at 20mA _____ GPM**.
3. In Hydraulic Status menu, check evaporator/condenser water flow rate value. (The flow rate value will be linear interpolated by actual reading and configured water flow rate at 4 mA/20 mA.)

Water flow can also be computed from water pressure sensors or water pressure drop sensors (see IOB4 wiring schematic). IOB4 Option must be Enabled and Water Flow Measurement option configured as “2 = WTR Flow PD” and the evaporator/condenser pressure drop baseline and water flow must be entered as inputs. Then review as above.

WATER PRESSURE DIFFERENCE MEASUREMENT

When entering and leaving water pressure transducers or 4 to 20 mA water pressure differential transducers are installed, the PIC 6 can compute or read the water pressure difference between entering and leaving water pressure, and thereby determine if the water is flowing. After the water pump is switched on, if the water pressure difference reaches the threshold, the water flow check is passed and the chiller can start. Otherwise there will be an alarm shutdown.

1. In **Configuration Menu** → **Option 2**, set **IOB4** → **Option** = Yes.
2. Set **Water Pressure Option** to either **1= WTR Flow PD TRD** (pressure transducer) or **2= WTR Flow PD MTR** (flow meter). For flow meter option **Water Pres Drop @20mA** will also have to be configured. Pressure drop will be calculated based on the 4-20 mA flow meter signal.
3. In “Hydraulic Status” menu, check Condenser Water Delta P, Condenser Water Flow, Evaporator Water Delta P, Evaporator Water Flow.

DIAGNOSTICS AND TROUBLESHOOTING

The 19XR PIC 6 control system has many fault tracing aid functions. The local interface and its various menus give access to all unit operating conditions.

If an operating fault is detected, an alarm is activated. The alarm code is displayed in the Alarms menu, sub-menus Reset alarms and Current alarms. The control may record up to 10 current alarms and alerts.

Displaying Alarms

The alarm icon  on the interface (see the section Icons on page 22) indicates unit status as follows:

- A flashing red LED shows that the unit is operating but there is an alert.
- A steady red LED shows that the unit has been shut down due to a fault.

The Reset Alarms option on the main menu displays up to five alarm codes that are active on the unit. Table 21 lists alarm codes.

Resetting Alarms

When the cause of the alarm has been identified and corrected, the alarm can be reset either automatically or manually (depending on the type of alarm). See Table 21 for alarms that are eligible for automatic reset.

In the event of a power supply interrupt, if Auto Restart Option is set to ENABLE in the Option Configuration menu, the unit restarts automatically without the need for an external command.

A manual reset must be run from the main menu via the Reset Alarms Feature.

Once the alarm has been corrected or reset, all information regarding solved alarms is stored in the Alarm History. Alarm History will store last 50 alarms even after alarms have been corrected or reset.

Alarm/Alert Codes

Table 21 lists PIC 6 alarm codes. Table 22 lists PIC 6 alert codes. These do not cause machine shutdown and are automatically reset when the situation returns to normal.

Table 21 — PIC 6 Alarm Codes

ALARM CODE (ALARMRST)	ALARM TEXT DESCRIPTION	RESET TYPE	ACTION TAKEN BY CONTROL	POSSIBLE CAUSE
TEMPERATURE SENSOR FAULTS				
Alm-200	Sensor Fault — Leaving Chilled Water	Automatic if the temperature measured by the sensor returns to normal	Unit shuts down	Check sensor resistance. Check for proper wiring between leaving chilled water temperature sensor and IOB connector. Check for disconnected, grounded, or shorted wiring. Check IOB channel type configurations.
Alm-201	Sensor Fault — Entering Chilled Water	Automatic if the temperature measured by the sensor returns to normal	Unit shuts down	Check sensor resistance. Check for proper wiring between entering chilled water temperature sensor and IOB connector. Check for disconnected, grounded, or shorted wiring. Check IOB channel type configurations.
Alm-202	Sensor Fault — Leaving Cond Water Temp	Automatic if the temperature measured by the sensor returns to normal	Unit shuts down	Check sensor resistance. Check for proper wiring between leaving condenser water temperature sensor and IOB connector. Check for disconnected, grounded, or shorted wiring. Check IOB channel type configurations.
Alm-203	Sensor Fault — Entering Cond Water Temp	Automatic if the temperature measured by the sensor returns to normal	Unit shuts down	Check sensor resistance. Check for proper wiring between entering condenser water temperature sensor and IOB connector. Check for disconnected, grounded, or shorted wiring. Check IOB channel type configurations.
Alm-204	Sensor Fault — Comp Discharge Temp	Automatic if the temperature measured by the sensor returns to normal	Unit shuts down	Check sensor resistance. Check for proper wiring between compressor discharge temperature sensor and connector. Check for disconnected, grounded, or shorted wiring.
Alm-205	Sensor Fault — Oil Sump Temp	Automatic if the temperature measured by the sensor returns to normal	Unit shuts down	Check sensor resistance. Check for proper wiring between oil sump temperature sensor and IOB connector. Check for disconnected, grounded, or shorted wiring.
Alm-206	Sensor Fault — Oil Supply Temp	Automatic if the temperature measured by the sensor returns to normal	Unit shuts down	Check sensor resistance. Check for proper wiring between oil supply temperature sensor and IOB connector. Check for disconnected, grounded, or shorted wiring.
Alm-207	Sensor Fault — Evap Refrig Liquid Temp	Automatic if the temperature measured by the sensor returns to normal	Unit shuts down	Check sensor resistance. Check for proper wiring between evaporator refrigerant liquid temperature sensor and IOB connector. Check for disconnected, grounded, or shorted wiring.
Alm-208	Sensor Fault — Low Speed Motor End Bearing Temp	Automatic if the temperature measured by the sensor returns to normal	Unit shuts down	Check sensor resistance. Check for proper wiring between low speed motor end bearing temperature sensor and IOB connector. Check for disconnected, grounded, or shorted wiring. Check IOB channel type configurations.
Alm-209	Sensor Fault — Low Speed Comp End Bearing Temp	Automatic if the temperature measured by the sensor returns to normal	Unit shuts down	Check sensor resistance. Check for proper wiring between low speed compressor end bearing temperature sensor and IOB connector. Check for disconnected, grounded, or shorted wiring. Check IOB channel type configurations.
Alm-210	Sensor Fault — High Speed Motor End Bearing Temp	Automatic if the temperature measured by the sensor returns to normal	Unit shuts down	Check sensor resistance. Check for proper wiring between high speed motor end bearing temperature sensor and IOB connector. Check for disconnected, grounded, or shorted wiring. Check IOB channel type configurations.

Table 21 — PIC 6 Alarm Codes (cont)

ALARM CODE (ALARMRST)	ALARM TEXT DESCRIPTION	RESET TYPE	ACTION TAKEN BY CONTROL	POSSIBLE CAUSE
TEMPERATURE SENSOR FAULTS (CONT)				
Alm-211	Sensor Fault — High Speed Comp End Bearing Temp	Automatic if the temperature measured by the sensor returns to normal	Unit shuts down	Check sensor resistance. Check for proper wiring between high speed compressor end bearing temperature sensor and IOB connector. Check for disconnected, grounded, or shorted wiring. Check IOB channel type configurations.
Alm-212	Sensor Fault — Comp Motor Winding 1 Temp	Automatic if the temperature measured by the sensor returns to normal	Unit shuts down	Check sensor resistance. Check for proper wiring between compressor motor temp 1 sensor and IOB connector. Check for disconnected, grounded, or shorted wiring. Check IOB channel type configurations.
Alm-213	Sensor Fault — Comp Motor Winding 2 Temp	Automatic if the temperature measured by the sensor returns to normal	Unit shuts down	Check sensor resistance. Check for proper wiring between compressor motor temp 2 sensor and IOB connector. Check for disconnected, grounded, or shorted wiring. Check IOB channel type configurations.
Alm-214	Sensor Fault — Comp Motor Winding 3 Temp	Automatic if the temperature measured by the sensor returns to normal	Unit shuts down	Check sensor resistance. Check for proper wiring between compressor motor temp 3 sensor and IOB connector. Check for disconnected, grounded, or shorted wiring. Check IOB channel type configurations.
Alm-215	Sensor Fault — Condenser Pressure	Automatic if the voltage measured by the sensor returns to normal	Unit shuts down	Check condenser pressure transducer wiring. Confirm that 5 v reference signal is available between IOB connector. Check for disconnected, grounded, or shorted wiring. Check for condensation in transducer connector. Check SW2 dip switch in IOB for the channel configuration.
Alm-216	Sensor Fault — Evaporator Pressure	Automatic if the voltage measured by the sensor returns to normal	Unit shuts down	Check evaporator pressure transducer wiring. Confirm that 5 v reference signal is available between IOB connector. Check for disconnected, grounded, or shorted wiring. Check for condensation in transducer connector. Check SW2 dip switch in IOB for the channel configuration.
Alm-217	Sensor Fault — Economizer Pressure	Automatic if the voltage measured by the sensor returns to normal	Unit shuts down	Check economizer pressure transducer wiring. Confirm that 5 v reference signal is available between IOB connector. Check for disconnected, grounded, or shorted wiring. Check for condensation in transducer connector. Check SW2 dip switch in IOB for the channel configuration.
Alm-218	Sensor Fault — Diffuser Pressure	Automatic if the voltage measured by the sensor returns to normal	Unit shuts down	Check diffuser pressure transducer wiring. Confirm that 5 v reference signal is available between IOB connector. Check for disconnected, grounded, or shorted wiring. Check for condensation in transducer connector. Check SW2 dip switch in IOB for the channel configuration.
Alm-219	Sensor Fault — Oil Sump Pressure	Automatic if the voltage measured by the sensor returns to normal	Unit shuts down	Check oil sump pressure transducer wiring. Confirm that 5 v reference signal is available between IOB connector. Check for disconnected, grounded, or shorted wiring. Check for condensation in transducer. Check SW2 dip switch in IOB for the channel configuration.

Table 21 — PIC 6 Alarm Codes (cont)

ALARM CODE (ALARMRST)	ALARM TEXT DESCRIPTION	RESET TYPE	ACTION TAKEN BY CONTROL	POSSIBLE CAUSE
TEMPERATURE SENSOR FAULTS (CONT)				
Alm-220	Sensor Fault — Oil Supply Pressure	Automatic if the voltage measured by the sensor returns to normal	Unit shuts down	Check oil supply pressure transducer wiring. Confirm that 5 v reference signal is available between IOB connectors. Check for disconnected, grounded, or shorted wiring. Check for condensation in transducer connector. Check SW2 dip switch in IOB for the channel configuration.
Alm-221	Sensor Fault — Comp Thrust Bearing Oil Temp	Automatic if the temperature measured by the sensor returns to normal.	Units shut down	Check sensor resistance. Check for proper wiring between Compressor Thrust Bearing Oil Temp Sensor and IOB connector. Check for disconnected, grounded, or shorted wiring.
Alm-223	Sensor Fault — Purge Comp Suction Temp	Automatic if the temperature measured by the sensor returns to normal	Units shut down	Check sensor resistance. Check for proper wiring between Purge Comp Suction Temp Sensor and IOB connector. Check for disconnected, grounded, or shorted wiring.
Alm-224	Sensor Fault — Carbon Tank Temp	Automatic if the temperature measured by the sensor returns to normal	Units shut down	Check sensor resistance. Check for proper wiring between Temp Sensor and IOB connector. Check for disconnected, grounded, or shorted wiring
Alm-225	Sensor Fault — Pump Inlet Pressure	Automatic if the pressure measured by the sensor returns to normal	Units shut down	Check sensor voltage supply and reading. Check for proper wiring between Temp Sensor and IOB connector. Check pressure transducer wiring. Confirm that 5 V reference signal is available between IOB connector. Check for disconnected, grounded, or shorted wiring. Check for condensation in transducer connector
Alm-226	Sensor Fault — Bearing Inlet Pressure	Automatic if the pressure measured by the sensor returns to normal	Units shut down	Check sensor voltage supply and reading. Check for proper wiring between Temp Sensor and IOB connector. Check pressure transducer wiring. Confirm that 5 V reference signal is available between IOB connector. Check for disconnected, grounded, or shorted wiring. Check for condensation in transducer connector
Alm-227	Sensor Fault — Bearing Outlet Pressure	Automatic if the pressure measured by the sensor returns to normal	Units shut down	Check sensor voltage supply and reading. Check for proper wiring between Temp Sensor and IOB connector. Check pressure transducer wiring. Confirm that 5 V reference signal is available between IOB connector. Check for disconnected, grounded, or shorted wiring. Check for condensation in transducer connector
Alm-228	Sensor Fault — Common CHWS Temp	Automatic if the temperature measured by the sensor returns to normal	Units shut down	Check sensor resistance. Check for proper wiring between Compressor Thrust Bearing Oil Temp Sensor and IOB connector. Check for disconnected, grounded, or shorted wiring
Alm-229	Sensor Fault — Common CHWR Temp	Automatic if the temperature measured by the sensor returns to normal	Units shut down	Check sensor resistance. Check for proper wiring between Compressor Thrust Bearing Oil Temp Sensor and IOB connector. Check for disconnected, grounded, or shorted wiring.

Table 21 — PIC 6 Alarm Codes (cont)

ALARM CODE (ALARMRST)	ALARM TEXT DESCRIPTION	RESET TYPE	ACTION TAKEN BY CONTROL	POSSIBLE CAUSE
PRESTART FAILURES				
Alm-230	Prestart Failure — High Bearing Temperature	Manual	Unit shuts down. Compressor is not allowed to start.	Check Comp Bearing Temp in Temperature screen. Check oil heater and oil cooler for proper operation. Check for low oil level, partially closed oil supply valves, clogged oil filters. Check the compressor bearing temperature sensor wiring and accuracy to IOB connector. Check Comp Bearing Temp Alert setting.
Alm-231	Prestart Failure — High Motor Temperature	Manual	Unit shuts down. Compressor is not allowed to start.	Check Comp Motor Wind Temp in Temperature screen. Check motor temperature sensor for wiring and accuracy to IOB connector. Check motor cooling line and isolation valves for proper operation or restrictions, check refrigerant filter/drier. Check for excessive starts within a short time span. Check Comp Motor Temp Override setting.
Alm-232	Prestart Failure — High Discharge Temperature	Manual	Unit shuts down. Compressor is not allowed to start.	Check Comp Discharge Temp in Temperature screen. Allow compressor discharge temperature sensor to cool. Check compressor discharge temperature sensor wiring to IOB connector. Check for excessive starts. Check Comp Discharge Alert setting.
Alm-233	Prestart Failure — Low Refrigerant Temperature	Manual	Unit shuts down. Compressor is not allowed to start.	Check Evaporator Pressure, Evap Sat Refrig Temp, and Evap Refrig Liquid Temp in Temperature screen. Check Evaporator Pressure transducer and Evaporator Refrigerant Liquid Temperature sensor wiring and accuracy to IOB connector. Check for low chilled water supply temperatures. Check refrigerant charge. Check REFRIG OVERRIDE DELTA T and EVAP REFRIG TRIPPOINT in Configuration screen.
Alm-234	Prestart Failure — Low Line Voltage	Manual	Unit shuts down. Compressor is not allowed to start.	Check ACTUAL LINE VOLTAGE. Check UNDERVOLTAGE THRESHOLD in ISM_CONF screen. Check voltage supply. Check wiring to ISM J3-L1, J3-L2, and J3-L3. Check voltage transformers and switch gear. Consult power utility if voltage is low.
Alm-235	Prestart Failure — High Line Voltage	Manual	Unit shuts down. Compressor is not allowed to start.	Check ACTUAL LINE VOLTAGE. Check OVERVOLTAGE THRESHOLD in ISM_CONF screen. Check voltage supply. Check voltage transformers and switch gear. Consult power utility if voltage is high.
Alm-236	Guide Vane 1 — Calibration Not Completed	Manual	Unit shuts down. Compressor is not allowed to start.	Perform Guide Vane Calibration in Quick Test screen. Check guide vane actuator feedback potentiometer and wiring to IOB connector.
Alm-237	Prestart Failure — No Power Supply	Manual	Unit shuts down. Compressor is not allowed to start.	If WATER VERIFICATION TIME has passed after REQUEST TO START had been sent, there is still no PERMISSION TO START received
Alm-239	Envelop Control Valve Calibration Not Completed	Manual	Unit shuts down. Compressor is not allowed to start.	EC valve calibration failed during control test mode or prestart check.
Alm-240	Damper valve not calibrated (for 19XR6-7) if configured for 4-20 mA damper valve control type	Manual	Compressor is not allowed to start.	Calibrate damper valve.

Table 21 — PIC 6 Alarm Codes (cont)

ALARM CODE (ALARMRST)	ALARM TEXT DESCRIPTION	RESET TYPE	ACTION TAKEN BY CONTROL	POSSIBLE CAUSE
PROTECTIVE LIMITS				
Alm-250	Protective Limit — Oil Pressure Difference Failure	Manual	Unit shuts down.	Check oil pump. Check oil filter. Check oil pump wiring.
Alm-251	Protective Limit — Low Chilled Water Flow	Manual	Unit shuts down.	Perform Chilled Water pump test in Quick Test screen. Check evaporator refrigerant liquid temperature and leaving chilled water temperature sensor accuracy and wiring to IOB. Check chilled water valves, pumps, and strainers. Check EVAP REFRIG TRIPPOINT, EVAP APPROACH ALERT, EVAP FLOW DELTA P CUTOUT, and WATER FLOW VERIFY TIME settings. Check load resistors, optional water flow switches or water flow delta P transducer calibration and wiring to IOB. Check for 5.0 v reference voltage between IOB connectors.
Alm-252	Protective Limit — Low Condenser Water Flow	Manual	Unit shuts down.	Perform Condenser Water pump test in Quick Test screen. Check condenser pressure transducer and leaving condenser water temperature sensor accuracy and wiring. Check condenser water valves and strainers. Check COND PRESS OVERRIDE, COND APPROACH ALERT, COND FLOW DELTA P CUTOUT, and WATER FLOW VERIFY TIME settings. Check load resistors, optional water flow switches or water flow delta P transducer calibration and wiring to IOB. Check for 5.0 v reference voltage between IOB connectors.
Alm-253	Protective Limit — High Discharge Temperature	Manual	Unit shuts down.	Check for closed compressor discharge isolation valve. Check if chiller was operating in surge conditions. Check compressor discharge temperature sensor resistance or voltage drop. Check for proper wiring to IOB connectors. Check for proper condenser flow and temperature. Check for proper inlet guide vane and optional diffuser actuator operation. Check for COMP DISCHARGE TEMP >220°F (104°C) Check for fouled tubes, plugged water strainers, or noncondensables in the condenser.
Alm-255	Protective Limit — High Motor Temperature	Manual	Unit shuts down.	Check compressor motor winding temperature sensor accuracy and wiring to IOB. Check motor cooling line and spray nozzle for proper operation or restrictions. Check motor cooling filter/drier and isolation valves. Look for refrigerant flow through motor cooling line sight glass. Check for excessive starts within a short time span.
Alm-256	Protective Limit — High Bearing Temperature	Manual	Unit shuts down.	Check oil heater for proper operation; confirm that oil heater is de-energized when compressor is running. Check for low oil level, partially closed oil line isolation valves, or clogged oil filter. Check oil cooler refrigerant thermal expansion valves; confirm that expansion valve bulbs are secured to the oil lines and insulated. Check compressor bearing temperature sensors accuracy and wiring to IOB. This fault can result from excessive operation at low load with low water flow to the evaporator or condenser. Very high discharge and volute temperatures may increase the oil sump temperature. Elevated sump temperature may result from an excessively high oil level reaching the bottom of the bull gear, causing it to churn the oil.

Table 21 — PIC 6 Alarm Codes (cont)

ALARM CODE (ALARMRST)	ALARM TEXT DESCRIPTION	RESET TYPE	ACTION TAKEN BY CONTROL	POSSIBLE CAUSE
PROTECTIVE LIMITS (CONT)				
Alm-257	Protective Limit — High Condenser Temperature	Manual	Unit shuts down.	Check CONDENSER PRESSURE. Check for high condenser water temperatures, low water flow, fouled tubes. Check for division plate/gasket bypass or plugged condenser water strainers. Check for noncondensables in condenser. Check condenser pressure transducer wiring and accuracy to IOB. Configure COND PRESS OVERRIDE in configuration screen. NOTE: This alarm is not caused by the high condenser pressure switch.
Alm-258	Protective Limit — Spare Safety Device	Manual	Unit shuts down.	Spare safety input has been closed.
Alm-259	Protective Limit — Excessive Compressor Surge	Manual	Unit shuts down.	Five SURGE PROTECTION COUNTS occurred within SURGE TIME PERIOD. VFD Only: Surge prevention alarm declared when ACTUAL VFD SPEED is at least 90%. Check for high condenser water temperatures, low water flow, fouled tubes. Check CONDENSER APPROACH. Check condenser water strainers. Check for division plate/gasket bypass. Check for noncondensables in condenser. Check surge prevention parameters in OPTIONS screen. Compare cooling tower control settings and performance against design/selection temperatures across the entire operating range of the chiller. Check EVAPORATOR APPROACH and chilled water flow.
Alm-260	Protective Limit — Compressor Start Relay Start Failure	Manual	Unit shuts down.	Check motor starter 1M contactor wiring. Check ISM current sensors.
Alm-261	Protective Limit — Evaporator Frozen	Manual	Unit shuts down.	Check CALC EVAP SAT TEMP, EVAP REFRIG LIQUID TEMP, and EVAP REFRIG TRIPPOINT. Check for proper refrigerant charge. Check float valve operation. Confirm that optional refrigerant liquid line isolation valve is open. Check for proper Chilled Water flow and temperature. Confirm that condenser water enters bottom row of condenser tubes first (reversed condenser water flow may cause refrigerant to stack in the condenser). Check evaporator pressure transducer and evaporator refrigerant liquid temperature sensor. Check for evaporator water box division plate gasket bypass. Check for fouled tubes.
Alm-263	Protective Limit — Invalid Diffuser Config	Manual	Unit shuts down.	Check SRD Configurations.
Alm-264	Protective Limit — Diffuser Position Fault	Manual	Unit shuts down.	Confirm that Diffuser Option in SRD Configuration screen has not been Enabled if compressor does not have a split ring diffuser. May indicate rotating stall condition. Check rotating stall transducer wiring accuracy and sealing. Check diffuser schedule and guide vane schedule in SRD Configuration screen. Check for proper operation of diffuser and inlet guide vane actuators including inlet guide vane calibration. Check diffuser actuator coupling for rotational slip. Check for electrical noise in IOB Diffuser Pressure wiring. Do not continue to operate compressor except for diagnostic purposes..

Table 21 — PIC 6 Alarm Codes (cont)

ALARM CODE (ALARMRST)	ALARM TEXT DESCRIPTION	RESET TYPE	ACTION TAKEN BY CONTROL	POSSIBLE CAUSE
PROTECTIVE LIMITS (CONT)				
Alm-265	Protective Limit — Refrigerant Leak	Manual	Unit shuts down.	REFRIGERANT LEAK OPTION is Enabled and the REFRIGERANT LEAK SENSOR output exceeded REFRIGERANT LEAK ALARM mA. Check for refrigerant leaks. Check leak detector for proper operation. Check REFRIGERANT LEAK ALARM mA setting in the OPTIONS screen. Check 4 to 20 mA or 1 to 5 v output from refrigerant leak sensor to IOB. Confirm that IOB SW2 dip switch 1 is in the correct position.
Alm-266	Protective Limit — IOB Low Voltage	Automatic	Unit shuts down.	Check IOB 24 VAC power supply and the transformer output voltage.
Alm-267	Protective Limit — Guide Vane Fault	Manual	Unit shuts down.	Alarm before start indicates guide vane opening has not closed to less than 4%. Alarm while running indicates guide vane position is < -1% or > 103%. Enter Quick Test and conduct Guide Vane Calibration. Check wiring between the guide vane feedback potentiometer and IOB terminals. Check the 10,000 ohm guide vane position feedback potentiometer or 4 to 20mA current.
Alm-268	Protective Limit — Damper Valve Fault	Manual	Unit shuts down.	Check damper valve wirings. Do a control test on the damper valve to check the feedback signals.
Alm-269	Protective Limit — EC Valve Fault	Manual	Unit shuts down.	Check EC valve wirings. Do a control test on the EC/HGBP valve to check the feedback signals.
Alm-270	Protective Limit — High Cond Water Flow	Manual	Unit shuts down.	Check condenser water pressure sensor and wirings.
Alm-271	Protective Limit — Emergency Stop	Automatic	Unit shuts down.	Check EMSTOP command from network and the remote stop dry contact from IOB.
Alm-272	Protective Limit — ISM Config Conflict	Automatic	Unit shuts down.	Configuration data in controller and ISM are mismatched. In Maintenance menu, choose Maintains ISM config → Delete ISM config: NO - Upload ISM configuration data to HMI YES - Download ISM configuration to ISM
Alm-273	Protective Limit — Swift Restart Limit Exceeded	Manual	Unit shuts down.	Understand the reason and correct why Swift Restart happens frequently.
Alm-274	Protective Limit — Chiller Lockout	Automatic	Unit shuts down.	Check chiller lockout input in IOB
Alm-275	Protective Limit — Fire Alarm	Automatic	Unit shuts down.	Check fire alarm input in IOB
Alm-276	Protective Limit — Stop Override	Manual	Unit shuts down.	Check stop override point status in GENUNIT table
Alm-280	Protective Limit — High VFD speed	Manual	Unit shuts down.	Check VFD actual speed
COMMUNICATION FAILURE				
Alm-282	Protective Limit — Displacement Switch	Manual	Unit shuts down.	Check impeller displacement switch.
Alm-283	Protective Limit — High Pressure Switch	Manual	Unit shuts down.	Check high pressure switch.
Alm-284	Protective Limit — Power Feedback Loss	Manual	Unit shuts down.	Check Power Feedback Input.
Alm - 285	Protective Limit - Low Bearing Delta Pres Difference	Automatic if the temperature measured by the sensor returns to normal	Unit shuts down	Check if the filter of refrigerant pump inlet is clogged. If clogged, please replace that filter. Check if refrigerant pump works. If pump fails, please replace refrigerant pump. Check if high float chamber has liquid. If no liquid, please wait until chiller automatically charge refrigerant into high float chamber. Check if bearing filter is clogged. If clogged, please replace bearing filter
Alm-290	Protective Limit – Long Time Purge Active	Automatic if the temperature measured by the sensor returns to normal	Unit shuts down.	Alarm comes on if the purge continuously pumpout for more than one hour and indicates a potential problem with the purge or possible a leak allowing non-condensables into the system

Table 21 — PIC 6 Alarm Codes (cont)

ALARM CODE (ALARMRST)	ALARM TEXT DESCRIPTION	RESET TYPE	ACTION TAKEN BY CONTROL	POSSIBLE CAUSE
COMMUNICATION FAILURE (CONT)				
Alm-291	Protective Limit — Drainage System Failure	Automatic if the temperature measured by the sensor returns to normal	Unit shuts down.	Alarm comes on if If drainage valve has been opened for more than Drainage Valve Action Alarm Time (default to 30 minutes) but purge level is still high. Could indicate a problem with drain valve or sensor indicating high purge level.
Alm-295	Protective Limit — High Bearing Inlet Temperature	Manual	Units shuts down.	Check sensor resistance. Check for proper wiring Temp Sensor and IOB connector. Check for disconnected, grounded, or shorted wiring
Alm-296	Protective Limit — High Evaporator Pressure	Manual	Unit shuts down.	Check evaporator pressure sensor input. Check evaporator pressure cutout configurations.
Alm-298	Protective Limit — Low Bearing Inlet Subcooling	Manual	Unit shuts down.	Check sensor resistance. Check for proper wiring Temp Sensor and IOB connector. Check for disconnected, grounded, or shorted wiring.
Alm-300	Loss Communication with ISM	Automatic when communication returns to normal (Swift Restart eligible)	Unit shuts down.	Check LEN communication cable. Check the wiring and termination resistor settings.
Alm-301	Loss of Communication with IOB 1	Automatic when communication returns to normal	Unit shuts down.	Check LEN communication cable. Check the wiring and termination resistor settings.
Alm-302	Loss of Communication with IOB 2	Automatic when communication returns to normal	Unit shuts down.	Check LEN communication cable. Check the wiring and termination resistor settings.
Alm-303	Loss of Communication with IOB 3	Automatic when communication returns to normal	Unit shuts down.	Check LEN communication cable. Check the wiring and termination resistor settings.
Alm-304	Loss of Communication with IOB 4	Automatic when communication returns to normal	Unit shuts down.	Check LEN communication cable. Check the wiring and termination resistor settings.
Alm-305	Loss of Communication with IOB 5	Automatic when communication returns to normal	Unit shuts down.	Check LEN communication cable. Check the wiring and termination resistor settings.
Alm-306	Loss of Communication with IOB 6	Automatic when communication returns to normal	Unit shuts down.	Check LEN communication cable. Check the wiring and termination resistor settings.
Alm-307	LEN Scan Error	Manual	Unit shuts down.	Check LEN bus hardware physical wiring and software log
Alm-308	Loss Communication with VFD	Automatic when communication returns to normal	Unit shuts down.	Bus installation fault or defective slave board
Alm-309	Loss Communication with VFD Gateway (LEN)	Manual	Unit shuts down.	Bus installation fault or defective slave board
Alm-310	Loss Communication with VFD (Modbus)	Manual	Unit shuts down.	Bus installation fault or defective slave board
Alm-311	Loss Communication With Danfoss VFD	Manual	Unit shuts down.	If {vfd_opt = 7} AND {LEN side Communication error with VFD lost for 14 [default, can be configurable] consecutive seconds}
Alm-350	19DV 1st Stage Bearing Temp	Manual	Unit shuts down.	Tested when the compressor is on whatever the run status and the communication between Main board and IOBs is ok, If compressor 1st Bearing Temp is outside the range of -39.5 to 244.5°F
Alm-351	19DV 2nd Stage Bearing Temp	Manual	Unit shuts down.	Tested when the compressor is on whatever the run status and the communication between Main board and IOBs is ok, If compressor 2nd Bearing Temp is outside the range of -39.5 to 244.5°F
Alm-352	19DV Pump Output Pressure	Manual	Unit shuts down.	Tested when the compressor is running and the communication between Main board and IOBs is functional. Alarm will occur if Bearing Outlet Transducer voltage is outside of range the range of 0.3V to 4.67V.
Alm-353	Heat Reclaim Entering Temp	Manual	Unit shuts down.	Tested when the compressor is on whatever the run status and the communication between Main board and IOBs is functional, If heat water entering temperature is outside the range of -39.5 to 244.5°F
Alm-354	Heat Reclaim Leaving Temp	Manual	Unit shuts down.	Tested when the compressor is on whatever the run status and the communication between Main board and IOBs is functional, If heat water entering temperature is outside the range of -39.5 to 244.5°F

Table 21 — PIC 6 Alarm Codes (cont)

ALARM CODE (ALARMRST)	ALARM TEXT DESCRIPTION	RESET TYPE	ACTION TAKEN BY CONTROL	POSSIBLE CAUSE
INTEGRATED STARTER MODULE ALARMS				
Alm-400	ISM Fault — Line Voltage Dropout	Manual (Swift Restart eligible)	Unit shuts down.	Temporary loss of voltage. SINGLE CYCLE DROPOUT in the ISM_CONF screen is Enabled and two LINE VOLTAGES < 50% MOTOR RATED LINE VOLTAGE. Check ISM_HIST screen. Disable Single Cycle Dropout in VFD_CONF screen.
Alm-401	ISM Fault — Line Phase Loss	Manual (Swift Restart eligible)	Unit shuts down.	Any LINE VOLTAGE < 50% MOTOR RATED LINE VOLTAGE, or there is an excessive difference between the smallest LINE CURRENT and the largest LINE CURRENT. Check the ISM_HIST screen. Check MOTOR RATED LINE VOLTAGE in ISM_CONF screen. Check phase to phase and phase to ground power distribution bus voltage. Check current transformer wiring leading to ISM terminal block J4 and line voltage wiring leading to ISM terminal block J3. Check wiring and hardware between building power supply and motor. Current imbalance may improve if power or motor leads are rotated in the same phase sequence. Consult power company. Medium voltage applications only: Check voltage potential transformers and VOLT TRANSFORMER RATIO in ISM_CONF screen.
Alm-402	ISM Fault — High Line Voltage	Manual (Swift Restart eligible)	Unit shuts down.	High LINE VOLTAGE for an excessive amount of time. Check LINE VOLTAGE in ISM_HIST screen. Check MOTOR RATED LINE VOLTAGE and OVERVOLTAGE THRESHOLD in ISM_CONF screen. Check phase to phase and phase to ground distribution bus voltage. Consult power company. Medium voltage applications only: Check voltage potential transformers and VOLT TRANSFORMER RATIO in ISM_CONF screen. Check wiring to ISM J3-VL1, J3-VL2 and J3-VL3.
Alm-403	ISM Fault — Low Line Voltage	Manual (Swift Restart eligible)	Unit shuts down.	Low LINE VOLTAGE for an excessive amount of time. Check LINE VOLTAGE in ISM_HIST screen. Check MOTOR RATED LINE VOLTAGE and UNDERVOLTAGE THRESHOLD in ISM_CONF screen. Check phase to phase and phase to ground distribution bus voltage. Check connections to ISM terminal block J3. Consult power company. Medium voltage applications only: Check voltage potential transformers and VOLT TRANSFORMER RATIO in ISM_CONF screen. Check wiring to ISM J3-VL1, J3-VL2 and J3-VL3.
Alm-404	ISM Fault — Line Current Imbalance	Manual (Swift Restart eligible)	Unit shuts down.	Current imbalance > CURRENT % IMBALANCE for greater than the CURRENT IMBALANCE TIME. Check settings in ISM_CONF screen. Check ISM_HIST screen. Check current transformer wiring leading to ISM terminal block J4. Verify phase to phase and phase to ground line voltage. Check wiring and hardware between building power supply and motor. Current imbalance may improve if power or motor leads are rotated in the same phase sequence.

Table 21 — PIC 6 Alarm Codes (cont)

ALARM CODE (ALARMRST)	ALARM TEXT DESCRIPTION	RESET TYPE	ACTION TAKEN BY CONTROL	POSSIBLE CAUSE
INTEGRATED STARTER MODULE ALARMS (CONT)				
Alm-405	ISM Fault — Line Voltage Imbalance	Manual	Unit shuts down.	Voltage Imbalance > VOLTAGE % IMBALANCE for greater than the VOLTAGE IMBALANCE TIME. Check settings in ISM_CONF screen. Check ISM_HIST screen. Check line voltage wiring leading to ISM terminal block J3. Verify phase to phase and phase to ground line voltage. Check wiring and hardware between building power supply and motor.
Alm-406	ISM Fault — Overload Trip	Manual	Unit shuts down.	Any phase current > 108% RLA for excessive time period. Alarm can result from significant load side current imbalance when running at full load. Check ISM_HIST screen. Check for consistent entering condenser water temperature and water flow rates. Check MOTOR RATED LOAD AMPS and STARTER LRA RATING in ISM_CONF screen. VFD applications only: Any phase current > 120% for excessive time period.
Alm-407	ISM Fault — Motor Locked Rotor Trip	Manual	Unit shuts down.	Any LINE CURRENT > MOTOR LOCKED ROTOR TRIP for excessive time while running after the LOCKED ROTOR START DELAY has expired. Check MOTOR LOCKED ROTOR TRIP and MOTOR CURRENT CT RATIO in ISM_CONF screen. Check motor nameplate data. Check ISM_HIST screen. Check motor wiring and motor winding resistance. Temporarily enable SINGLE CYCLE DROP OUT to capture power disturbances.
Alm-408	ISM Fault — Starter Lock Rotor Trip	Manual	Unit shuts down.	Any LINE CURRENT > MOTOR LOCKED ROTOR TRIP for excessive time while running after the LOCKED ROTOR START DELAY has expired. Check MOTOR LOCKED ROTOR TRIP and MOTOR CURRENT CT RATIO in ISM_CONF screen. Check motor nameplate data. Check ISM_HIST screen. Check motor wiring and motor winding resistance. Temporarily enable SINGLE CYCLE DROP OUT to capture power disturbances.
Alm-409	ISM Fault — Ground Fault	Manual	Unit shuts down.	Any GROUND FAULT current > GROUND FAULT CURRENT threshold for a duration > GROUND FAULT PERSISTENCE after the GROUND FAULT START DELAY has expired. Check these settings and GROUND FAULT CT RATIO in ISM_CONF screen. Check ISM_HIST screen. Confirm that ground fault current transformer orientation is correct, and that the correct motor leads have been routed through the ground fault current transformers in the right direction. Check for condensation on motor terminals or inside motor leads. Check motor power leads for phase to phase or phase to ground shorts. Disconnect motor from starter and merger motor windings to ground and phase to phase. Call Carrier Service.
Alm-410	ISM Fault — Phase Reversal Trip	Manual	Unit shuts down.	The ISM has detected that the input power is phased BAC instead of ABC. Confirm that the phase sequence wired to ISM terminal block J3 is consistent with the power wiring to the starter. Swap two power leads at the starter. Check ISM Status under the Maintenance Menu.

Table 21 — PIC 6 Alarm Codes (cont)

ALARM CODE (ALARMRST)	ALARM TEXT DESCRIPTION	RESET TYPE	ACTION TAKEN BY CONTROL	POSSIBLE CAUSE
INTEGRATED STARTER MODULE ALARMS (CONT)				
Alm-411	ISM Fault — Line Frequency Trip	Manual	Unit shuts down.	LINE FREQUENCY FAULTING in ISM_CONF screen is enabled and the LINE FREQUENCY has deviated approximately 7% from nominal value. Check ISM_HIST screen. Check FREQUENCY = 60 HZ? in ISM_CONF screen. Check line frequency. If operating from a generator, check generator size and speed.
Alm-412	ISM Fault — Starter Module Reset	Manual (Swift Restart eligible)	Unit shuts down.	AUTO RESTART OPTION in OPTIONS screen is disabled and there was a temporary loss of 115 v ISM control voltage supply. Check ISM_HIST screen. Check wiring leading to ISM terminals J1-LL1 and J1-LL2. Check control power circuit breaker, control power transformer and control power circuit fuses. Monitor chiller utility power for disruptions. Improve ISM ground connection; apply measures to reduce electrical noise to ISM. Consult power company.
Alm-413	ISM Fault — Start Contact Fault	Manual	Unit shuts down.	Check 1M dry contact input.
Alm-414	ISM Fault — Transition Contact Fault	Manual	Unit shuts down.	Check 2M dry contact input.
Alm-415	ISM Fault — Oil Pump/High Pressure Switch Failure	Manual	Unit shuts down.	Check high pressure switch and oil pump.
Alm-416	ISM Fault — Starter Fault	Manual	Unit shuts down.	The ISM has received a start command and the starter has declared a Fault. The dry contacts connected to ISM J2-7 and J2-8 are open. See starter display for starter Fault Code. For Benshaw Inc. RediStart starters, view RediStart MICRO display. For VFD, check VFD display Fault History. Clear VFD faults with VFD keypad. For Allen-Bradley wye delta starters with RLA > 718 A, the TR3 timer may have expired as a result of a delayed transition.
Alm-417	ISM Fault — Motor Amps Not Sensed	Manual	Unit shuts down.	The ISM has not sensed sufficient current for an excessive delay after 1M has closed. Check ISM_HIST screen Check the MOTOR CURRENT CT RATIO and the MOTOR RATED LOAD AMPS in the ISM_CONF screen. Check VFD OPTION configuration. Check for wiring of current transformers to the J4 ISM terminals. Check if main circuit breaker has tripped. Check ISM History under the Maintenance Menu.
Alm-418	ISM Fault — Excessive Acceleration Time	Manual	Unit shuts down.	Any line current remains high for an excessive time duration following 1M aux and either 2M aux or transition contact closure. Check that inlet guide vanes are fully closed at start-up. Check ISM_HIST screen. Check Motor Rated Load Amps in ISM_CONF screen. Reduce condenser pressure if possible.
Alm-419	ISM Fault — Excessive Motor Amps	Manual	Unit shuts down.	AVERAGE LINE CURRENT > 110% for an excessive amount of time. Check MOTOR RATED LOAD AMPS and MOTOR CURRENT CT RATIO in ISM_CONF time. Check ISM_HIST screen. Check for conditions that cause excessive lift. Check guide vane actuator for proper operation. Confirm that guide vanes will fully close prior to start-up.
Alm-420	ISM Fault — Start Transition Contact Failure	Manual	Unit shuts down.	Check 1M and 2M dry contact inputs

Table 21 — PIC 6 Alarm Codes (cont)

ALARM CODE (ALARMRST)	ALARM TEXT DESCRIPTION	RESET TYPE	ACTION TAKEN BY CONTROL	POSSIBLE CAUSE
INTEGRATED STARTER MODULE ALARMS (CONT)				
Alm-421	ISM Fault — Motor Amps When Stopped	Manual	Unit shuts down.	High line current measured on any phase after power up or STOP command. Check the MOTOR CURRENT CT RATIO and the MOTOR RATED LOAD AMPS in the ISM_CONF screen. Check VFD OPTION in SETUP 2 screen. Check ISM_HIST screen. Check for high inrush current during power-up. Confirm that the starter de-energizes the motor when the ISM removes 115 v from ISM J9-2. Confirm that the correct STARTER TYPE has been selected in the ISM_CONF screen.
Alm-422	ISM Fault — Starter Module Failure	Manual	Unit shuts down.	Check ISM Hardware.
Alm-423	ISM Fault — Calibration Factor Error	Manual	Unit shuts down.	Check ISM Calibration Values.
Alm-424	ISM Fault — Invalid Configuration Error	Manual	Unit shuts down.	Check ISM Configurations.
Alm-425	VFD Fault — Single Cycle Dropout	Manual	Unit shuts down.	Temporary loss of voltage. Disable Single Cycle Dropout in CFGUMVFD screen.
Alm-426	VFD Fault — Line Current Imbalance	Manual	Unit shuts down.	Check phase to phase and phase to ground power distribution bus voltage. Check Line Current Imbalance% in CFGUMVFD screen. Consult power company.
Alm-427	VFD Fault — High Line Voltage	Manual	Unit shuts down.	Check phase to phase and phase to ground distribution bus voltage. Consult power company.
Alm-428	VFD Fault — Low Line Voltage	Manual	Unit shuts down.	Check phase to phase and phase to ground distribution bus voltage. Consult power company.
Alm-429	VFD Fault — Low DC Bus Voltage	Manual	Unit shuts down.	Verify phase-to-phase and phase-to-ground line voltage. VFD Circuit Board malfunction. Call Carrier Service.
Alm-430	VFD Fault — High DC Bus Voltage	Manual	Unit shuts down.	Verify phase to phase and phase to ground line voltage. Monitor AC line for high transient voltage conditions. VFD Circuit Board malfunction. Call Carrier Service.
Alm-431	VFD Fault — VFD Power On Reset	Manual	Unit shuts down.	Temporary loss of VFD control voltage. Check VFD control power breaker, transformer, and fuses.
Alm-432	VFD Fault — Ground Fault	Manual	Unit shuts down.	Check for condensation on motor terminals. Check motor power leads for phase to phase or phase to ground shorts. Disconnect motor from VFD and megger motor. Call Carrier Service.
Alm-433	VFD Fault — Line Phase Reversal	Manual	Unit shuts down.	Reverse connections of any two line conductors to circuit breaker.
Alm-434	VFD Fault — Motor Overload Trip	Manual	Unit shuts down.	Check VFD configurations. Any phase current > 106% RLA. Can result from significant load side current imbalance when running at full load. Check entering condenser water temperature and water flow rate. Check Motor Rated Load Amps in CFGUMVFD screen.
Alm-435	VFD Fault — Rectifier Power Fault	Manual	Unit shuts down.	Check VFD status. Malfunction within VFD Power Module. Call Carrier Service.
Alm-436	VFD Fault — Inverter Power Fault	Manual	Unit shuts down.	Check VFD status. Malfunction within VFD Power Module. Call Carrier Service.
Alm-437	VFD Fault — Rectifier Overcurrent	Manual	Unit shuts down.	Check VFD status. Check for high water temperatures or changes in water flow rates.
Alm-438	VFD Fault — Inverter Overcurrent	Manual	Unit shuts down.	Check VFD status. Check for high entering water temperature or low condenser water flow. Check current settings in CFGUMVFD screen.

Table 21 — PIC 6 Alarm Codes (cont)

ALARM CODE (ALARMRST)	ALARM TEXT DESCRIPTION	RESET TYPE	ACTION TAKEN BY CONTROL	POSSIBLE CAUSE
INTEGRATED STARTER MODULE ALARMS (CONT)				
Alm-439	VFD Fault — Condenser High Pressure	Manual	Unit shuts down.	Check Compressor Discharge High Pressure switch wiring and accuracy. Check for high condenser water temperatures, low water flow, fouled tubes. Check for division plate/gasket bypass. Check for noncondensables in refrigerant.
Alm-440	VFD Fault — Motor Amps Not Sensed	Manual	Unit shuts down.	Check main circuit breaker for trip. Increase Current % Imbalance in CFGUMVFD screen.
Alm-441	VFD Fault — Motor Acceleration Fault	Manual	Unit shuts down.	Check that inlet guide vanes are fully closed at start-up. Check Motor Rated Load Amps in CFGUMVFD screen. Reduce unit pressure if possible.
Alm-442	VFD Fault — Stop Fault	Manual	Unit shuts down.	Check Inverter power unit. VFD Circuit Board malfunction. Call Carrier Service.
Alm-443	VFD Fault — Rectifier Overtemp	Manual	Unit shuts down.	Check Cooling and VFD Config. Check that VFD refrigerant isolation valves are open. Check VFD refrigerant cooling solenoid and refrigerant strainer. Check for proper VFD cooling fan operation and blockage.
Alm-444	VFD Fault — Inverter Overtemp	Manual	Unit shuts down.	Check Cooling and VFD Config. Check that VFD refrigerant isolation valves are open. Check VFD refrigerant cooling solenoid and refrigerant strainer. Check for proper VFD cooling fan operation and blockage.
Alm-445	VFD Fault — Motor Current Imbalance	Manual	Unit shuts down.	Check Motor Current Imbalance% in CFGUMVFD screen.
Alm-446	VFD Fault — Line Voltage Imbalance	Manual	Unit shuts down.	Check phase-to-phase and phase-to-ground distribution bus voltage. Increase Line Voltage Imbalance% in CFGUMVFD screen.
Alm-447	VFD Fault — Frequency Fault	Manual	Unit shuts down.	Check power supply. If operating from a generator, check generator size and speed. Check utility power supply.
Alm-448	VFD Fault — VFD Comm Fail	Manual	Unit shuts down.	Check VFD communication wiring and connectors. Check status lights on DPI Communications Interface Board. Call Carrier Service.
Alm-449	VFD Fault — VFD Fault	Manual	Unit shuts down.	Check fault code and possible cause in corresponding type of VFD user manuals. Call Carrier Service.
Alm-450	VFD Fault — VFD Start Inhibit	Manual	Unit shuts down.	The VFD Start Inhibit is derived from the Alarm bit being set in the VFD. The conditions causing the alarm must be corrected in the VFD to enable subsequent starts and operation.
Alm-451	VFD Fault — VFD Checksum Error	Manual	Unit shuts down.	Press Reset to Restore Configuration. Actual VFD checksum does not match calculated value.
Alm-452	VFD Fault — Inductor Overtemp Switch	Manual	Unit shuts down.	Check Temp Switch and Cooling Fans. Check for cooling fan air flow obstructions.
Alm-453	VFD Fault — Incompatibility Fault	Manual	Unit shuts down.	Load compatible version files into drive.
Alm-454	VFD Fault—Main Power Failure	Manual	Unit shuts down.	Check main power.

NOTE: Some alarm codes (identified in the Reset Type column) are eligible for Swift Restart when the Auto Restart option is enabled. The Swift Restart algorithm allows for quicker restart and decreases the normal start-up delays and verification times.

Table 22 — PIC 6 Alert Codes

ALERT CODE (ALARMRST)	ALERT TEXT DESCRIPTION	RESET TYPE	ACTION TAKEN BY CONTROL	POSSIBLE CAUSE
PRESTART ALERTS				
Alt-100	Prestart Alert — Starts Limit Exceeded	Automatic when the situation returns to normal	Turn on Alert relay.	Check STARTS IN 12 HOURS in Run times screen. Enable "Enable Excessive Starts" option in Service menu if additional start is required. NOTE: Recycle restarts and auto restarts after power failure are not counted in Starts Limit.
Alt-101	Prestart Alert — Low Oil Temperature	Automatic when the situation returns to normal	Alert relay is ON.	Check OIL SUMP TEMP in default screen. Check oil heater contactor/relay and power. Check oil sump temperature sensor wiring and accuracy. Check oil level and oil pump operation. Check EVAP SAT TEMP.
Alt-102	Prestart Alert — High Condenser Pressure	Automatic when the situation returns to normal	Alert relay is ON.	Check CONDENSER PRESSURE. Check condenser pressure transducer wiring and accuracy. Check for high condenser water temperatures. Check COND PRESS OVERRIDE in configuration.
Alt-103	Prestart Alert — Excessive Recycle Starts	Automatic when the situation returns to normal	Alert relay is ON.	Chiller load is too low to keep compressor on line and there have been more than 5 starts in 4 hours. Increase chiller load, adjust hot gas bypass to open at a higher load, increase recycle RESTART DELTA T in service menu. Check hot gas bypass isolation valve position.
Alt-104	Prestart Alert — Waiting for Start Permission	Automatic when the situation returns to normal	Alert relay is ON.	Power request option is enabled.
SENSOR ALERTS				
Alt-120	Sensor Alert — Remote Temperature Out of Range	Automatic when the situation returns to normal	Alert relay is ON.	Type 2 Temperature Reset is Enabled and remote temperature reset sensor is out of range. Check ENABLE RESET TYPE and TEMPERATURE RESET settings in TEMP_CNTL screen. Check remote temperature reset sensor resistance or voltage drop. Check for proper wiring to IOB. Check IOB channel type configurations and SW2 dip switch setting in IOB.
Alt-121	Sensor Alert — Auto Water Temp Reset	Automatic when the situation returns to normal	Alert relay is ON.	Check Temp Reset Configuration. Confirm that Auto Water Temp Reset Input is between 4 mA and 20 mA. Confirm that wiring to IOB connector is not grounded.
Alt-122	Sensor Alert — Auto Demand Limit Input	Automatic when the situation returns to normal	Alert relay is ON.	20 mA DEMAND LIMIT OPT is Enabled, Ice Build is not Active, and Auto Demand Limit Input on IOB is < 2 mA. Check 20 mA DEMAND LIMIT OPT and DEMAND LIMIT AT 20 mA in Service screen. Confirm that Auto Demand Limit Input is between 4 mA and 20 mA. Confirm that wiring to IOB connector is not grounded. Check IOB channel type configurations and SW2 dip switch setting in IOB.
Alt-123	Sensor Alert — VFD Speed Out of Range	Automatic when the situation returns to normal	Alert relay is ON.	Check VFD speed feedback input in ISM.
Alt-124	Sensor Alert — Humidity Sensor	Automatic when the situation returns to normal	Alert relay is ON.	Check humidity sensor input in IOB.
Alt-125	Sensor Alert — Refrigerant Leak Input	Automatic when the situation returns to normal	Alert relay is ON.	Check refrigerant leak optional input in IOB.
Alt-126	Sensor Alert — Diffuser Pos Feedback	Automatic when the situation returns to normal	Alert relay is ON.	Check diffuser position feedback.
Alt-127	Sensor Alert — VFD Current Input	Automatic when the situation returns to normal	Alert relay is ON.	Check VFD current input.
Alt-128	Sensor Alert — High Cond Water Pressure	Automatic when the situation returns to normal	Alert relay is ON.	Check optional condenser water pressure sensor. Check condenser water flow.
Alt-129	Sensor Alert — Leaving Cond Water Temp	Automatic when the situation returns to normal	Alert relay is ON.	Leaving condenser water temperature sensor reading is out of range. Check leaving condenser water sensor resistance or voltage drop. Check for proper wiring to IOB. Check IOB channel type configurations.
Alt-130	Sensor Alert — Entering Cond Water Temp	Automatic when the situation returns to normal	Alert relay is ON.	Entering condenser water temperature sensor reading is out of range. Check entering condenser water sensor resistance or voltage drop. Check for proper wiring to IOB. Check IOB channel type configurations.
Alt-131	Sensor Alert — Entering Cond Water Press	Automatic when the situation returns to normal	Alert relay is ON.	Check entering condenser water pressure sensor voltage drop. Check for proper wiring to IOB. Check IOB channel type configurations.

Table 22 — PIC 6 Alert Codes (cont)

ALERT CODE (ALARMRST)	ALERT TEXT DESCRIPTION	RESET TYPE	ACTION TAKEN BY CONTROL	POSSIBLE CAUSE
SENSOR ALERTS (CONT)				
Alt-132	Sensor Alert — Entering Chilled Water Press	Automatic when the situation returns to normal	Alert relay is ON.	Check entering chilled water pressure sensor voltage drop. Check for proper wiring to IOB. Check IOB channel type configurations.
Alt-133	Sensor Alert — Leaving Cond Water Press	Automatic when the situation returns to normal	Alert relay is ON.	Check leaving condenser water pressure sensor voltage drop. Check for proper wiring to IOB. Check IOB channel type configurations.
Alt-134	Sensor Alert — Leaving Chilled Water Press	Automatic when the situation returns to normal	Alert relay is ON.	Check leaving chilled water pressure sensor voltage drop. Check for proper wiring to IOB. Check IOB channel type configurations.
Alt-135	Sensor Alert — Guide Vane Position	Automatic when the situation returns to normal	Alert relay is ON.	Check guide vane position feedback. Check guide vane actuator wiring.
Alt-136	Configuration Error — Temp Reset	Automatic when the situation returns to normal	Alert relay is ON.	Check temperature reset configurations.
Alt-137	Configuration Error — Controlled Water Delta T Reset	Automatic when the situation returns to normal	Alert relay is ON.	Check controlled water temperature reset configurations.
Alt-138	Configuration Error — Head Pressure	Automatic when the situation returns to normal	Alert relay is ON.	Check head pressure configurations.
Alt-139	Guide Vane 2 Position	Automatic when the situation returns to normal	Alert relay is ON.	Check guide vane 2 position feedback.
PROCESS ALERTS				
Alt-146	High Ref Filter Delta Pressure	Automatic when the situation returns to normal	Alert relay is ON	Alert is active if 19DV and refrigerant pump is ON and pump lift exceeds 9 psig.
Alt-147	Drainage System Failure	Automatic when the situation returns to normal	Alert relay is ON.	Alert is active if purge option is ON and drain valve is ON continuously for 20 minutes.
Alt-148	Purge Daily Pumpout Limit Exceed	Automatic when the situation returns to normal	Alert relay is ON.	Alert is active if purge time is greater than defined in configuration.
Alt-149	Low Bearing Delta Pres Difference	Automatic when the situation returns to normal	Alert relay is ON.	Alert is active if 19DV and compressor start is activated and bearing delta pressure is less than 13 psi.
Alt-150	Process Alert — Low Discharge Superheat	Automatic when the situation returns to normal	Alert relay is ON.	Check for oil loss from compressor or excess oil charge. Check for excess refrigerant charge. Verify that the valves in the oil reclaim lines are open. Check oil reclaim strainers. Check actual SUPERHEAT in Temperature screen.
Alt-151	Process Alert — High Evaporator Approach	Automatic when the situation returns to normal	Alert relay is ON.	Check EVAP APPROACH ALERT setting. Check Evaporator Water Flow. Check evaporator refrigerant liquid temperature and leaving chilled water temperature sensor resistances and voltage drop. Check evaporator refrigerant liquid temperature and leaving chilled water temperature sensor wiring to the IOB terminal block. Check for oil loss or low refrigerant charge. Check oil reclaim line isolation valves and strainers. Confirm that the optional refrigerant liquid line isolation valve is open. Check for float valve operation and for refrigerant stacking in the condenser. Check chilled water valves and strainers. Check for air in the evaporator water box or division plate bypass. Check for fouled tubes. Confirm that the oil reclaim system is working. Take oil sample and check for mineral oil contamination. Check for 20°F (11°C) temperature difference between leaving chilled water and leaving condenser water.
Alt-152	Process Alert — High Condenser Approach	Automatic when the situation returns to normal	Alert relay is ON.	Check COND APPROACH ALERT setting. Check condenser water flow. Check condenser pressure transducer and leaving condenser water temperature sensor resistance or voltage drop. Check condenser shell temperature against condenser pressure measured with a refrigerant gage for evidence of noncondensables in refrigerant charge. Check for condenser water box division plate bypass. Check condenser pressure transducer and leaving condenser water sensor wiring to the CCM. Check for air in the condenser water box. Confirm that the condenser tubes are not fouled.
Alt-153	Process Alert — High Noise Region	Automatic when the situation returns to normal	Alert relay is ON.	Check the envelop control configurations and running conditions. Check EC/HGBP valve action.

Table 22 — PIC 6 Alert Codes (cont)

ALERT CODE (ALARMRST)	ALERT TEXT DESCRIPTION	RESET TYPE	ACTION TAKEN BY CONTROL	POSSIBLE CAUSE
PROCESS ALERTS (CONT)				
Alt-154	Process Alert — Damper Valve Alert	Automatic when the situation returns to normal	Alert relay is ON.	Check damper valve wiring and position feedback inputs.
Alt-155	Process Alert — Low Oil Pressure Difference	Automatic when the situation returns to normal	Alert relay is ON.	Check oil pump wiring and oil filter. Quick test oil pump as necessary.
Alt-156	Process Alert — EC Valve Alert	Automatic when the situation returns to normal	Alert relay is ON.	Check EC/HGBP valve wiring and feedback inputs.
Alt-157	Process Alert — High Condenser Pressure Chiller Off	Automatic when the situation returns to normal	Alert relay is ON.	Check condenser pressure sensor input, and check condenser pressure override configurations.
Alt-158	Process Alert — Prognostic Alert	Automatic	Alert relay is ON.	Check prognostic status and configuration screen for detailed information.
Alt-159	Process Alert — LEN Scan Warning	Manual	Alert relay is ON.	Check LEN bus traffic with bus monitor.
Alt-160	Process Alert — Oil Filter Replacement	Manual	Alert relay is ON.	Check oil filter.
Alt-161	Process Alert — Transducer Calibration	Manual	Alert relay is ON.	Do the indicated transducer calibration.
Alt-162	Process Alert — Low Refrigerant Charge	Manual	Alert relay is ON.	Confirm that the unit has low refrigerant charge before adding refrigerant into chiller.
Alt-164	Process Alert — Displacement Switch	Manual	Alert relay is ON.	Check impeller displacement switch.
Alt-165	Process Alert — High Oil Supply Temperature	Automatic when the situation returns to normal	Alert relay is ON.	Check oil supply temperature and OIL EXV status (not only applicable if Oil EXV control enabled).
Alt-166	Process Alert — Condenser Flushing	Automatic	Alert relay is ON.	Flush condenser.
Alt-167	Process Alert — Customer Alert	Automatic	Alert relay is ON.	Check Customer Alert input contact.
Alt-168	Protective Limit—Condenser Frozen	Manual	Unit shuts down.	The Cond Sat Refrig Temp is less than the Condenser Freeze Point. Check Condenser Freeze Point in configuration. Condenser water too cold or chiller shut down with brine below 32°F (0°C) in cooler so equalization temperature in chiller approached 32°F (0°C). Check condenser pressure transducer and wiring to IOB. Check condenser water temperature sensors and wiring to IOB. Check refrigerant charge.
Alt-169	Process Alert — High Evaporator Pressure	Automatic	Alert relay is ON.	Check evaporator pressure sensor input. Check evaporator pressure override configurations.
MASTER SLAVE ALERTS				
Alt-170	Master Slave Alert — Master Slave Same Address	Manual	Master slave work independent.	Check master slave address configurations.
Alt-171	Master Slave Alert — Conflict SW Version	Manual	Master slave work independent.	Check master slave software version number.
Alt-172	Master Slave Alert — Conflict Cooling Heating Mode	Manual	Master slave work independent.	Check master slave cooling heating selection.
Alt-173	Master Slave Alert — Incorrect Slave Control Type	Manual	Master slave work independent.	Check slave control type.
Alt-174	Master Slave Alert — Slave Tripout	Manual, automatic in Master side	Master slave work independent.	Check slave chiller alarms.
Alt-175	Master Slave Alert — Incorrect Master Control Type	Manual	Master slave work independent.	Check master control type.
Alt-176	Master Slave Alert — No Communication Master Slave	Automatic	Master slave work independent.	Check communication between master and slave, wiring, etc.
Alt-179	Master Slave Alert — Master CCN Write Rejection	Manual	Master slave work independent.	Check CCN communication, hardware, and software.
Alt-180	Master Slave Alert — Address Not Slave	Manual	Master slave work independent.	Check master slave configurations.

Event States

An event state is a specific set of conditions that the controller may encounter when controlling the chiller. Event states are repeatable and predictable, and represent known states of the control. When the control is in a particular state, a unique message is associated with that state. The event state messages are displayed on the default screen of the control panel and are listed in Table 23.

Table 23 — Event States

EVENT NO.	DESCRIPTION
1	Chiller Off
2	Chiller Tripout
3	Pumpdown Lockout
4	Terminate Pumpdown Lockout
5	Guide Vane 1 Calibration
6	Quick Test in Progress
7	Ice Build Done
8	Ice Build In Progress
9	Free Cooling In Progress
10	Auto Restart Pending
11	Condenser Flush In Progress
13	Envelop Control Valve Calibration
20	Startup Inhibited — Loadshed in Effect
21	Prestart Check in Progress
22	Timeout — Delay to Start in XX Min
23	Recycle in Progress
24	Startup in Progress
25	Swift Restart In Progress
30	Ramp Loading — Temperature
31	Ramp Loading — Motor Load
32	Ramp Loading — Capacity Inhibit
39	Demand Limit — Capacity Inhibit
40	Demand Limit — Capacity Decrease
41	Demand Limit — Inhibit Clamp
45	Override — High Condenser Pressure
47	Override — High Motor Temperature
48	Override — Low Evap Refrig Temp
50	Override — High Bearing Temp
51	Override — Low Discharge Superheat
52	Override — Manual VFD Speed Target
53	Override — High Motor Current
54	Override — High Discharge Temp
55	Override — Low Source Temp
60	Running — Temp Reset by 4-20 mA Signal
61	Running — Temp Reset by Remote Temp Sensor
62	Running — Temp Reset by Water DT
63	Running — Cooling Leaving Chilled Water
64	Running — Cooling Entering Chilled Water
65	Running — Heating Leaving Cond Water
66	Running — Heating Entering Cond Water
67	Envelop Control — Surge Correction
68	Envelop Control — Acts Before Recycle Shutdown
69	Envelop Control — Low Load Application
70	Envelop Control — Forced
71	Running — VFD Rampdown
72	Running — Guide Vane Position Forced
73	Running — VFD Speed Forced
74	Surge Prevention — Low
75	Surge Prevention — High
76	Surge Protection
77	Running — VFD Overcurrent
79	Running — Damper Valve Forced
80	Operation — Oil EXV Forced
81	Running — Head Pressure Valve Forced
85	Running — Vapor Source Valve Forced
90	Shutdown — Normal
91	Shutdown — Alarm
93	Shutdown — Recycle
94	Shutdown — Recycle Ice Build
95	Shutdown — Compressor Deenergized
96	Shutdown — Emergency Stop
97	Transducer Calibration in Effect
98	ISM Calibration in Effect

SETTINGS FOR THE CONTROLLER

Controller Ethernet and Gateway/DNS Configuration can be configured by accessing *Main Menu* → *System Configuration*.

Unit IP Address

On the System Configuration menu, press Ethernet Configuration to display the ethernet parameters. See Fig. 57.

NOTE: You must request an IP address, the subnet mask, and the default gateway from the system administrator before connecting the unit to the local Ethernet network.

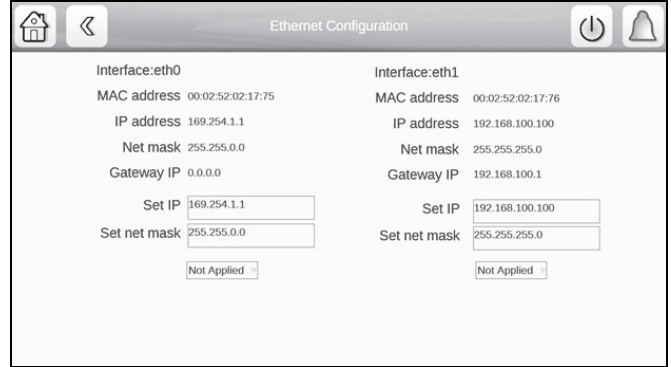

Fig. 57 — Ethernet Configuration Screen

Gateway/DNS Configuration is done in the Gateway/DNS Config Menu. Default gateway is entered into the Gateway/DNS Config Menu. See Fig. 58.

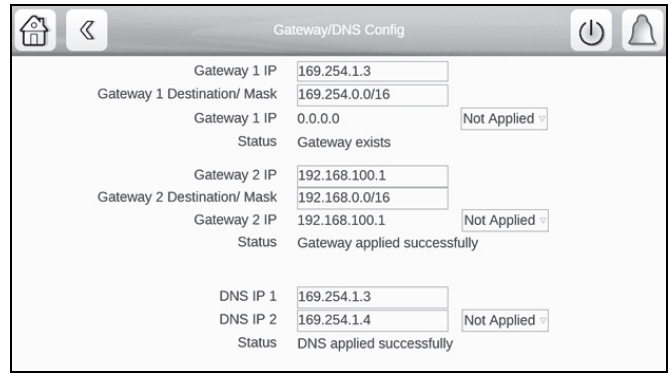

Fig. 58 — TCP/IP Address Screen

Upon changing a value, select the Not Applied icon and select Apply. The values will change on the screen and are now saved into the controller. See Fig. 59.

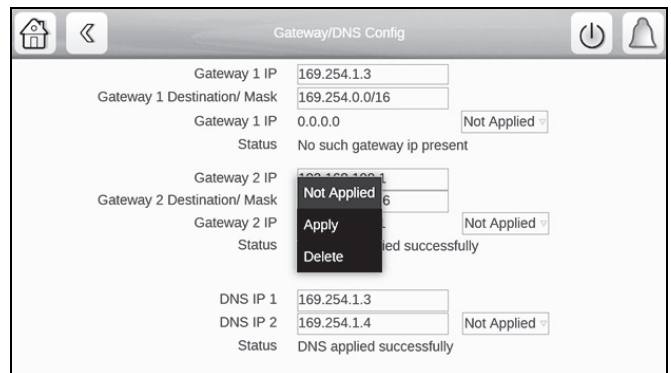

Fig. 59 — Save Changes

Default parameters are shown; to modify, select and edit a specific parameter.

TOUCH SCREEN CALIBRATION

Depending on the user and the position of the panel, it may be necessary to calibrate the touch screen if the cursor does not move precisely with the user's touch. To activate the calibration process the user must touch the touch screen in excess of 15 seconds which activates the process where a cross-hair successively appears in various screen positions. Touch the center of the cross-hair sight with a touch pen or similar blunt-ended stylus (do not use a metal object). When the cross-hair sight is touched, it moves to a new position; touch the center of the cross-hairs again. When all positions have been configured, the cross-hairs disappear. This completes the calibration.

Touch Screen Configuration Language and Units

To set the language for touch screen configuration screens, press the Globe on the Main Menu screen. The Language and Unit Selection screen offers the options shown in Fig. 60.



Fig. 60 — Touch Screen Configuration Language

COMMUNICATION PROBLEMS

Hardware Problems

See Table 24 for potential communication issues caused by hardware problems.

Web Interface Problems

See Table 25 for potential communication issues caused by web interface issues. The intranet site of the unit is the IP address.

NOTE: The unit cannot automatically obtain the network parameters via a DHCP server.

Ethernet/IP Connection Problems

Use the following methods to troubleshoot:

UNIT IS POINT-TO-POINT CONNECTED TO A PC

Ensure controller is powered on prior to configuration and check Ethernet connection and PC Network Interface Card (NIC).

NOTE: In addition to the following procedure, it may be necessary to check the Ethernet connection and/or configure the PC network board.

In Windows 7, open Network and Sharing Center window and choose Local Area Connection. Select Properties. See Fig. 61.

Table 24 — Hardware Problems

SYMPTOMS	POSSIBLE CAUSES	CHECKS	SOLUTIONS
The unit does not respond to the instructions sent by the supervision PC on the CCN bus.	Problem at the RS485 converter level of the PC or connection problem on the primary CCN bus.	Check the CCN cable connections. The unit CCN address is 0.1 and the communication speed is 9600 baud by default.	Replace the RS485 connector.
Communication problem when connecting two buses (primary bus and secondary bus).	Electrical problem between 0 v CCN of the primary bus and 0 v CCN of the secondary bus.	Check the connection of the metal part of the interface casing to earth.	Connect the metal part of the interface casing to earth.

Table 25 — Web Interface Problems

SYMPTOMS	POSSIBLE CAUSES	CHECKS	SOLUTIONS
Start-up page loads, then goes to fault state.	Network property details are not valid. Ethernet network is not available.	Check the network parameters. Check to see if the orange LED on the unit is flashing.	Contact your system administrator. Check the Ethernet connection to the local network if the orange LED does not flash.
While accessing the unit via the web browser, the Java platform launches, but remains blocked. No file is loaded.	Proxy server problem in the local network.	Contact your system administrator.	In agreement with the system administrator, open the Runtime Java control panel and select Direct Connection in the system parameters and/or request in the web browser (Tools→Options→Connection→System parameters) that no proxy server is used to go to the local addresses. If possible, uncheck "use of an automatic configuration script." Restart the web browser.
The application has been launched, but the screens are not shown in the web browser.	A proxy server is used to access the unit and this supplies the old screens to the browser. Incorrect configuration of the Java application.	Check that the web browser does not go via a proxy server to access the unit. Check that the Java application does not store the internet files on the PC.	Open the browser and in the system connection parameters add the IP address of the unit in the proxy exceptions. (Tools→Options→Connection→System parameters→"No proxy for"). See the section Java Application Configuration on page 58.

NOTES:

1. The unit cannot automatically obtain the network parameters via a DHCP (Dynamic Host Configuration Protocol) server.
2. The intranet site address of the unit is the IP address.

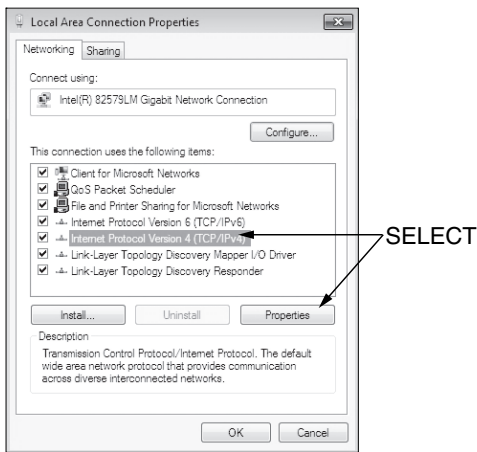

Fig. 61 — Local Area Connection Properties

The Internet Protocol Properties window is displayed.

- If no IP address is configured in the General and Alternative Configuration tabs, the unit IP address must be configured to 169.254.xxx.xxx. Modify the unit IP address and then restart the system.
- If the PC has a fixed IP address configured in one of the two tabs (General and Alternative Configuration), the IP address of the PC and the unit IP address must have the system and sub-system fields in common. The last part of the IP address is the host number and must be unique on the sub-system. For example: Unit address — 172.30.101.11 and PC address — 172.30.101.182. In this example, 172.30 corresponds to the network, and 101 corresponds to the sub-system. Carry out the necessary modifications and try to access the unit again.

In the case of a problem, open a Windows command window (Start, Execute, type `cmd` and press Enter), then type the command `ping`, followed by the unit IP address. In the example shown in Fig. 62, the PC receives four positive responses (replies).

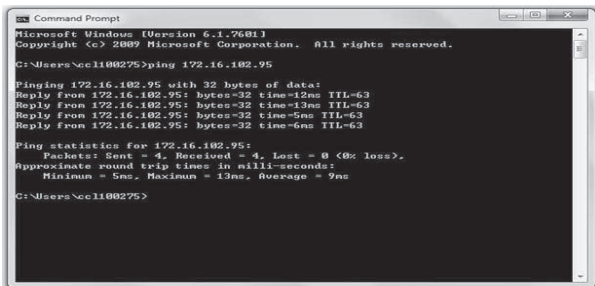

Fig. 62 — Ping — Positive Replies

In the example shown in Fig. 63, the PC receives four negative responses (request timed out).

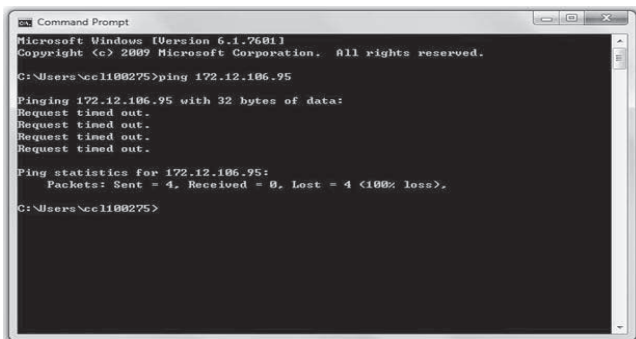

Fig. 63 — Ping — Negative Responses

If the PC receives four negative responses, check the internet browser parameters to determine if a proxy server or an automatic configuration script has been configured. If this is the case:

- Deselect the proxy server or the configuration script and restart the browser
- Or refer to the section Java Application Configuration

Try to access the unit again. If the PC still does not receive a response from the unit, restart the unit. Contact your system administrator.

UNIT IS CONNECTED TO THE LOCAL NETWORK

The unit is connected to the local network by an uncrossed cable, and the unit is energized. Open a Windows command window (Start, Execute, type `cmd` and press Enter), then type the command `ping`, followed by the unit IP address.

If the responses are positive (see Fig. 62), the internet browser configuration is faulty. Check the system parameters of the internet browser to determine if a proxy server or an automatic configuration script has been configured. See Fig. 64.

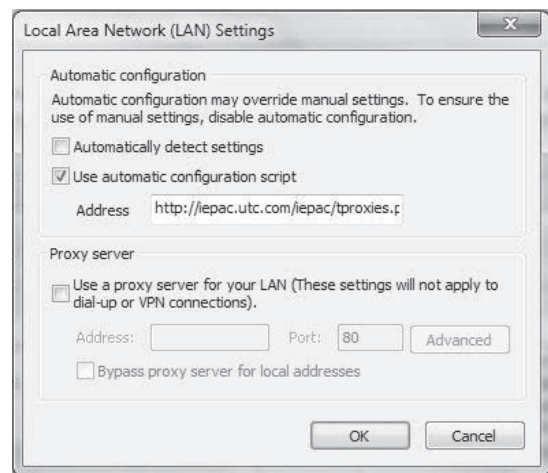

Fig. 64 — Local Area Network Settings

If a proxy server is used, add the unit IP address to the exceptions list of the proxy server (advanced proxy configuration). See Fig. 65.

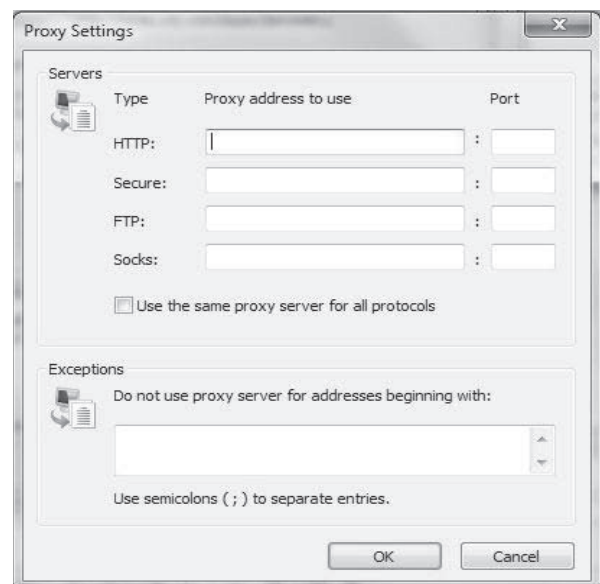

Fig. 65 — Proxy Settings

If a configuration script is used, it is not possible to add the unit IP address to the exceptions list. In this case, see the section Java Application Configuration below.

If the response to the “ping” command is negative, verify the IP address of the PC and the IP address of the unit. They must have the system network and sub-system in common. The last part of the IP address is the host number and must be unique on the sub-system; for example: Unit address — 172.30.101.11 and PC address — 172.30.101.182. In this example, 172.30 corresponds to the system network, and 101 corresponds to the sub-system. The host numbers are 11 and 182 respectively.

ETHERNET CONNECTION ON THE PC

Open the network configuration window of the PC and double-click Network Connections. Find the system interface board and check that no red “X” appears on the icon.

The connection to the local network must be authorized and in the connected status. If this is not the case, check the connections and authorize/repair the network connection.

JAVA APPLICATION CONFIGURATION

Open the Internet configuration window of the PC and double-click the Java application icon. If Java is not installed, a free download is available at <http://www.java.com>.

If Java has already been installed, check if it is used by other applications. If so, check that these are compatible with the following settings in the Java control panel. See Fig. 66.

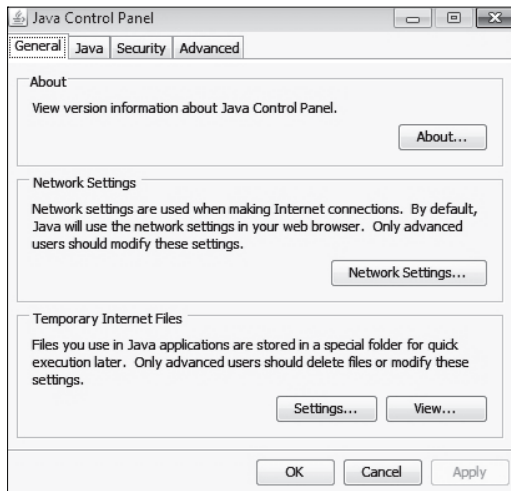

Fig. 66 — Java Control Panel

- Network settings: In the Java Control Panel, click Network Settings. Select a direct connection to bypass the proxy server or select the automatic configuration script. See Fig. 67.

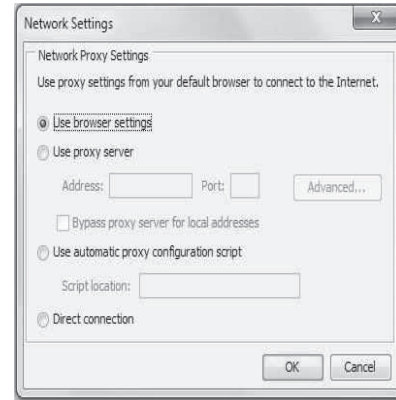

Fig. 67 — Network Settings

- Temporary internet files: In the Java Control Panel, click Settings in the Temporary Internet Files section. Be sure the setting Keep temporary files on my computer is unchecked (clear). See Fig. 68.

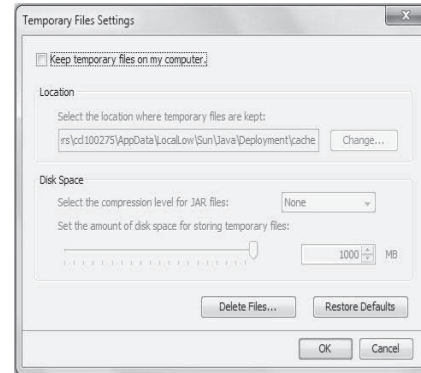
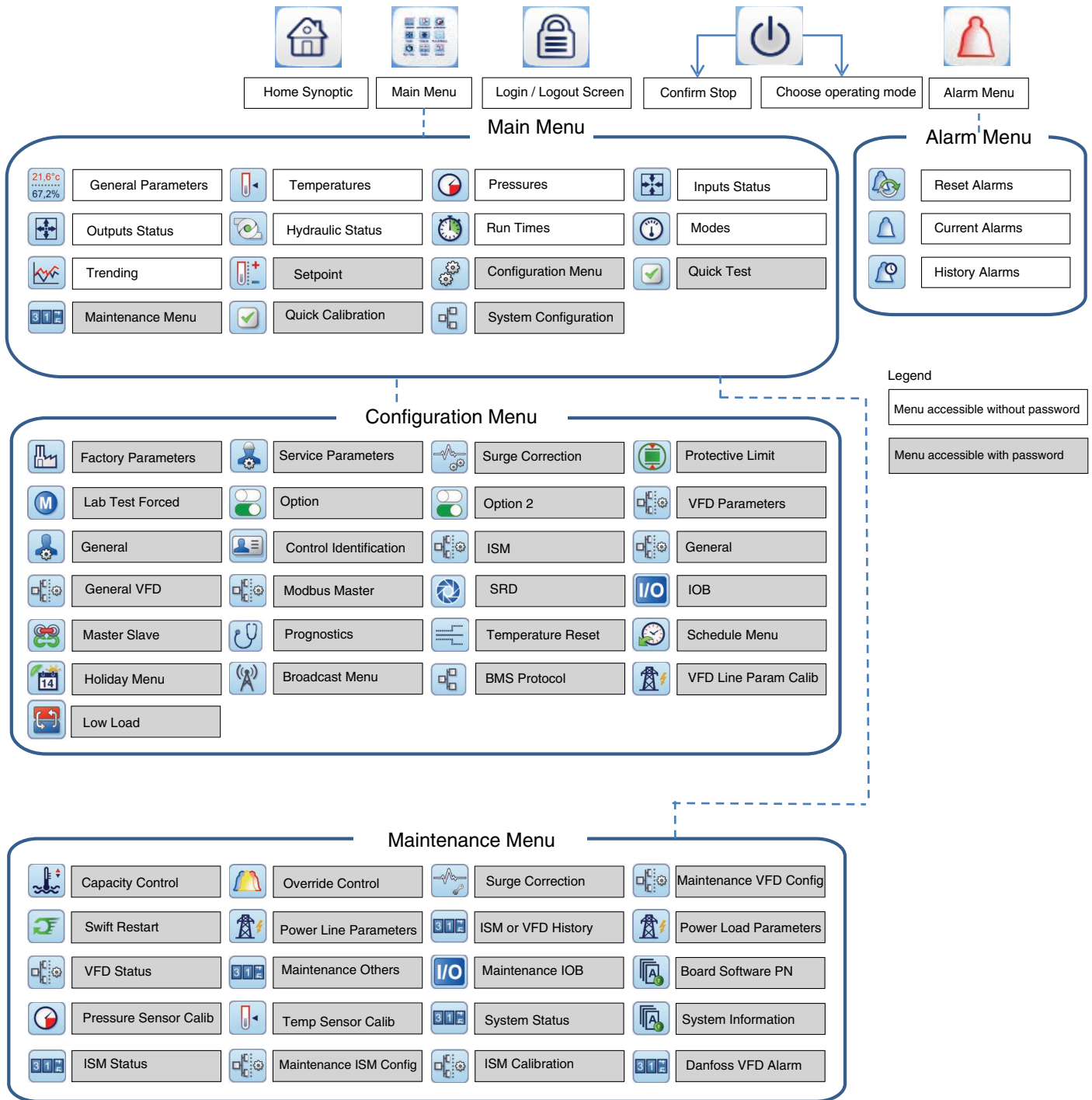

Fig. 68 — Temporary File Settings

APPENDIX A — PIC 6 SCREEN AND TABLE STRUCTURE



19XR Menu — Note that the available menu options shown in Menu are dependent upon unit selections.

Fig. A — Screen Structure

APPENDIX A — PIC 6 SCREEN AND TABLE STRUCTURE (cont)

Main Menu Description

ICON	DISPLAYED TEXT*	ACCESS	ASSOCIATED TABLE	PAGE NO.
	General Parameters	All	GENUNIT	61
	Temperatures	All	TEMP	62
	Pressures	All	PRESSURE	62
	Inputs Status	All	INPUTS	63
	Outputs Status	All	OUTPUTS	64
	Hydraulic Status	All	HYDRLIC	65
	Run Times	All	RUNTIME	66
	Modes	All	MODES	66
	Trending	All	TRENDING	—
	Setpoint	User	SETPOINT	66
	Configuration Menu	User	CONFIG	67
	Quick Test	Service	QCK_TEST	80
	Maintenance Menu	Service	MAINTAIN	81
	Quick Calibration	Service	QCK_CAL	
	System Configuration	User	System Configuration	

* Displayed text depends on the selected language (default is English).
 NOTE: In most cases User login does not gain access to all configurations screens in a given menu.

APPENDIX A — PIC 6 SCREEN AND TABLE STRUCTURE (cont)

General Parameters

CCN TABLE NAME: GENUNIT

PIC 6 PATH: Main Menu → General Parameters

LINE	PIC 6 DESCRIPTION	CCN NAME	RANGE	DEFAULT VALUE*	UNIT	READ/WRITE
1	Control Mode 0 = Local, 1 = Network 2 = Remote, 3 = Local Sched	ctl_mode	0 to 3			RO
2	Compressor1 Run Status	cm_stas1	0 to 16†			RO
3	Deter Start Stop Command	stop/start				RO
4	Network: Cmd Start/Stop	CHIL_S_S	NO/YES			RW**
5	Network:Cmd Occupied	CHIL_OCC	NO/YES			RW**
6	Cooling / Heating Select	HC_SEL	COOL/HEAT	COOL		RW
7	Control Point	CTRL_PNT	10.0 to 160.0		°F	RW**
8	Control Point Reset	reset	-30.00 to 30.00		°F	RO
9	Actual Setpoint	setpoint	10.0 to 150.0		°F	RO
10	Percent Load Current	AMPS_P	0.0 to 999.0		%	RO
11	Motor Percent Kilowatts	KW_P	0 to 100		%	RO
12	Actual Demand Limit	DEM_LIM	10.0 to 100.0	100	%	RW**
13	Emergency Stop	EMSTOP	NO/YES	0		RW**
14	Chiller State Number	ch_state	0 to 500			RO
15	Local Schedule Occupied	oc_occ	NO/YES			RO
16	Ice Schedule Occupied	ice_occ	NO/YES			RO
17	Master Slave Start Stop Command	ms_stsp	STOP/START			RO
18	Remote Reset Alarm	REM_RST	NO/YES			RO
19	Stop Override	STP_OVER	NO/YES	NO		RW
20	Start Free Cooling	FC_START	NO/YES	NO		RW
21	Start Condenser Flush	CF_START	NO/YES	NO		RW
22	BACnet Occupied	BAC_OCC	0 to 1			RO

LEGEND

RO — Read Only

RW — Read/Write

* Default value is shown only if configurable in this table.

† 0 = OFF

1 = CTLTEST

2 = PUMPDOWN

3 = LOCKOUT

4 = RECYCLE

5 = TRIPOUT

6 = TIMEOUT

7 = PRESTART

8 = STARTUP

9 = AUTORST

10 = RAMPING

11 = RUNNING

12 = OVERRIDE

13 = DEMAND

14 = SHUTDOWN

15 = FREECOOL

16 = CONDFLSH

** RW from network.

APPENDIX A — PIC 6 SCREEN AND TABLE STRUCTURE (cont)

Temperatures

CCN TABLE NAME: TEMP

PIC 6 PATH: Main Menu → Temperatures

LINE	PIC 6 DESCRIPTION	CCN NAME	RANGE	DEFAULT VALUE*	UNIT	READ/WRITE
1	Entering Chilled Water	ECW	-40.0 to 245		°F	RO
2	Leaving Chilled Water	LCW	-40.0 to 245		°F	RO
3	Entering Condenser Water	ECDW	-40.0 to 245		°F	RO
4	Leaving Condenser Water	LCDW	-40.0 to 245		°F	RO
5	Evap Sat Refrig Temp	EVAP_SAT	-40.0 to 245		°F	RO
6	Evap Refrig Liquid Temp	EVAP_T	-40.0 to 245		°F	RO
7	Evaporator Approach	evap_app	0.0 to 99.0		°F	RO
8	Condenser Approach	cond_app	0.0 to 99.0		°F	RO
9	Cond Sat Refrig Temp	COND_SAT	-40.0 to 245		°F	RO
10	Comp Discharge Temp	DGT	-40.0 to 245		°F	RO
11	Discharge Superheat	DSH	-20.0 to 99.0		°F	RO
12	Thrust Bearing Oil Temp	MTRB_OIL	-40.0 to 245		°F	RO
13	Thrust Bearing Temp	MTRB	-40.0 to 245		°F	RO
14	Low Speed ME Brg Temp	MTRB1	-40.0 to 245		°F	RO
15	Low Speed CE Brg Temp	MTRB2	-40.0 to 245		°F	RO
16	High Speed ME Brg Temp	MTRB3	-40.0 to 245		°F	RO
17	High Speed CE Brg Temp	MTRB4	-40.0 to 245		°F	RO
18	Comp Motor Winding 1 Temp	MTRW1	-40.0 to 245		°F	RO
19	Comp Motor Winding 2 Temp	MTRW2	-40.0 to 245		°F	RO
20	Comp Motor Winding 3 Temp	MTRW3	-40.0 to 245		°F	RO
21	Oil Sump Temp	OILT_SMP	-40.0 to 245		°F	RO
22	Oil Supply Temp	OILT_DIS	-40.0 to 245		°F	RO
23	Actual Lift	LIFT_A	0.0 to 200.0		°F	RO
24	Remote Reset Sensor	R_RESET	-40.0 to 245		°F	RO
25	Common CHWS Temp	CHWS_T	-40 to 245		°F	RO
26	Common CHWR Temp	CHWR_T	-40 to 245		°F	RO

Pressures (Associated Table: PRESSURE)

CCN TABLE NAME: PRESSURE

PIC 6 PATH: Main Menu → Pressures

LINE	PIC 6 DESCRIPTION	CCN NAME	RANGE	DEFAULT VALUE*	UNIT	READ/WRITE
1	Evaporator Pressure	EVAP_P	-6.7 to 420.0		psig	RO
2	Condenser Pressure	COND_P	-6.7 to 420.0		psig	RO
3	Economizer Pressure	ECON_P	-6.7 to 420.0		psig	RO
4	Oil Supply Pressure	OILP_DIS	-6.7 to 420.0		psig	RO
5	Oil Sump Pressure	OILP_SMP	-6.7 to 420.0		psig	RO
6	Oil Pump Delta P	OIL_PD	-6.7 to 420.0		psig	RO
7	Oil Pump Delta P Offset	pd_off	-5.0 to 5.0		psi	RW
8	Diffuser Pressure	DIFF_P	-6.7 to 420.0		psig	RO
9	Head Pressure Reference	HEAD_P	-6.7 to 420.0		psig	RO

LEGEND

RO — Read Only

*Default value is shown only if configurable in this table.

APPENDIX A — PIC 6 SCREEN AND TABLE STRUCTURE (cont)

Inputs Status

CCN TABLE NAME: INPUTS

PIC 6 PATH: Main Menu → Inputs Status

LINE	PIC 6 DESCRIPTION	CCN NAME	RANGE	DEFAULT VALUE*	UNIT	READ/WRITE
1	Compressor Start Contact	STAR_AUX	OPEN/CLOSE			RO
2	Compressor Run Contact	RUN_AUX	OPEN/CLOSE			RO
3	Damper Valve Fully Closed	DMP_FC	NO/YES			RO
4	Damper Valve Fully Opened	DMP_FO	NO/YES			RO
5	Damper Valve Status 0=Closed, 1=Interim, 2=Opened 3=Failure	DMP_ACT	0 to 3			RO
6	EC Valve Fully Closed	HGBP_FC	NO/YES			RO
7	EC Valve Fully Opened	HGBP_FO	NO/YES			RO
8	EC Valve Status 0=Closed, 1=Interim, 2=Opened 3=Failure	HGBP_ACT	0 to 3			RO
9	High Pressure Switch	HP_SW	OPEN/CLOSE			RO
10	Remote Contact	REM_CON	OPEN/CLOSE			RO
11	Remote Stop Contact	REM_STOP	OPEN/CLOSE			RO
12	Emergency Stop Contact	E_STOP	OPEN/CLOSE			RO
13	Ice Build Contact	ICE_CON	OPEN/CLOSE			RO
14	Chiller Lockout	REM_LOCK	OPEN/CLOSE			RO
15	Spare Safety Input	SAFETY	OPEN/CLOSE			RO
16	Starter Fault Feedback	STARTFLT	OPEN/CLOSE			RO
17	Fire Security Interlock	FS_LOCK	OPEN/CLOSE			RO
18	Guide Vane 1 Actual Ohms	GV1_OHMS			ohms	RO
19	Guide Vane 1 Actual Pos	GV1_ACT			%	RO
20	Actual VFD Speed Per	VFD_ACT			%	RO
21	Diffuser Actual Pos	DIFF_ACT			%	RO
22	Auto Demand Limit Input	AUTO_DEM			mA	RO
23	Auto Water Temp Reset	AUTO_RES			mA	RO
24	Refrig Leak Sensor	REF_LEAK			mA	RO
25	VFD Speed Feedback	VFD_IN			V	RO
26	GV1 Pos Feedback	GV1_MA			mA	RO
27	VFD Current Input	VFDC_MA			mA	RO
28	Actual ECV Pos Per	HGBPACTP			%	RO
29	ECV Current Feedback	HGBP_MA			mA	RO
30	ISM Trip Relay Status	TRIPR	OPEN/CLOSE			RO
31	BACnet Dongle	bacdongl	NO/YES			RO
32	Displacement Switch	SHAFTDIS	OPEN/CLOSE			RO
33	Power Request Feedback	POW_FDB	NO/YES			RO
34	Free Cool Start Switch	FC_SS	Off/On			RO
35	Customer Alert	CUS_ALE	OPEN/CLOSE			RO

LEGEND

RO — Read Only

*Default value is shown only if configurable in this table.

APPENDIX A — PIC 6 SCREEN AND TABLE STRUCTURE (cont)

Outputs Status

CCN TABLE NAME: OUTPUTS

PIC 6 PATH: Main Menu → Outputs Status

LINE	PIC 6 DESCRIPTION	CCN NAME	RANGE	DEFAULT VALUE*	UNIT	READ/WRITE
1	Diffuser Output	DIFF_OUT	4.0 to 20.0		mA	RO
2	Head Pres Output	HDPV_OUT	4.0 to 20.0		mA	RO
3	Head Pres2 Output	HDPV_OU2	4.0 to 20.0		mA	RO
4	Chiller Status Output	CHST_OUT	4.0 to 20.0		mA	RO
5	Chiller Run Status Relay	RUN_STAT	OFF/ON			RO
6	VFD Speed Output	VFD_OUT	4.0 to 20.0		mA	RO
7	Oil EXV Output	EXV_OUT	4.0 to 20.0		mA	RO
8	Oil EXV Target	exv_tgt	0.0 to 100.0		%	RO
9	Oil Pump VFD Output mA	OP_VFD	4.0 to 20.0		mA	RO
10	Oil Pump VFD Target	op_vfd_t			%	RO
11	Head Pres Valve Tgt Pos	hdpv_tgt	0.0 to 100.0		%	RO
12	Guide Vane 1 Output	GV1_OUT	0.0 to 20.8		mA	RO
13	EC Valve Output mA	HGBP_OUT	4.0 to 20.0		mA	RO
14	Alarm Relay	ALM	OFF/ON		OFF/ON	RO
15	Alert Relay	ALE	OFF/ON		OFF/ON	RO
16	Compressor Start Relay	COMP_SR	OFF/ON		OFF/ON	RO
17	Starter Trans Sw Status	TRANS	OFF/ON		OFF/ON	RO
18	Damper Valve Close	DMP_CL	OFF/ON		OFF/ON	RO
19	Damper Valve Open	DMP_OP	OFF/ON		OFF/ON	RO
20	Guide Vane 1 Decrease	GV1_DEC	OFF/ON		OFF/ON	RO
21	Guide Vane 1 Increase	GV1_INC	OFF/ON		OFF/ON	RO
22	EC Valve Close	HGBP_OFF	OFF/ON		OFF/ON	RO
23	EC Valve Open	HGBP_ON	OFF/ON		OFF/ON	RO
24	Oil Heater Relay	OIL_HEAT	OFF/ON		OFF/ON	RO
25	Oil Pump Relay	OIL_PUMP	OFF/ON		OFF/ON	RO
26	Tower Fan Relay High	TFR_HIGH	OFF/ON		OFF/ON	RO
27	Tower Fan Relay Low	TFR_LOW	OFF/ON		OFF/ON	RO
28	Damper Valve Tgt Pos 0=Close, 1=Hold, 2=Open	dmp_tgt	0 to 2			RO
29	EC Valve Tgt Pos 0=Close, 1=Hold, 2=Open	hgbp_tgt	0 to 2			RO
30	Power Request	POW_REQ	OFF/ON			RO
31	Free Cooling Mode	FC_MODE	NO/YES			RO
32	VFD Coolant Solenoid	VFD_SOL	OFF/ON			RO
33	Vapor Source SV	VS_SV	OFF/ON			RO
34	Economizer Bypass VLV	ECBY_VLV	OFF/ON		OFF/ON	RO
35	Economizer Isolation VLV	ECON_IV	OFF/ON		OFF/ON	RO

LEGEND

RO — Read Only

*Default value is shown only if configurable in this table.

APPENDIX A — PIC 6 SCREEN AND TABLE STRUCTURE (cont)

Hydraulic Status

CCN TABLE NAME: HYDRLIC

PIC 6 PATH: Main Menu → Hydraulic Status

LINE	PIC 6 DESCRIPTION	CCN NAME	RANGE	DEFAULT VALUE*	UNIT	READ/WRITE
1	Condenser Water Flow	CDW_FLOW	NO/YES			RO
2	Cond Water Flow Value	CDW_FV	0-10,000	0.0	GPM	RO
3	Entering Cond Water Pres	COND_EWP	-6.7 to 420.0		psig	RO
4	Leaving Cond Water Pres	COND_LWP	-6.7 to 420.0		psig	RO
5	Condenser Water Delta P	cdw_off	-10.0-10.0	0.0	psi	RW
6	Condenser Delta P Offset	cdw_off	-10.0-10.0	0.0	psig	RW
7	Cond Water Pulldown/Min	cdw_pull	-20 to 20.0		°F	RO
8	Condenser Water Pump	CDWP	OFF/ON			RO
9	Chilled Water Pump	CHWP	OFF/ON			RO
10	Chilled Water Flow	CHW_FLOW	NO/YES			RO
11	Chilled Water Flow Value	CHW_FV	-10.0 to 10.0	0.0	GPM	RW
12	Entering Chilled Water P	EVAP_EWP	-6.7 to 420.0		psig	RO
13	Leaving Chilled Water P	EVAP_LWP	-6.7 to 420.0		psig	RO
14	Chilled Water Delta P	chw_pd	-6.7 to 420.0		psig	RO
15	Chilled Delta P Offset	chw_off	-10 to 10.00	0.0	psig	RW
16	Chilled Water Pulldown/Min	chw_pull	-20 to 20.0		°F	RO
17	Chilled Water Flow Input	CHWF_IN	4 to 20		mA	RO
18	Cond Water Flow Input	CDWF_IN	4 to 20		mA	RO
19	Chilled Water Pres Drop	CHW_PDMA	4 to 20		mA	RO
20	Cond Water Pres Drop	CDW_PDMA	4 to 20		mA	RO
21	Evap Water Flow Switch	EVAP_FS	OPEN/CLOSE			
22	Cond Water Flow Switch	COND_FS	OPEN/CLOSE			
23	Tower Fan Relay High	TFR_HI	OFF/ON			RO
24	Tower Fan Relay Low	TFR_LO	OFF/ON			RO
25	Controlled Water DT	ctrlw_dt	-40.0 to 245.0		°F	RO
26	Cond Flow Status 0=Fail or Not Started 1=Success, 2=Verifying	cdw_fl_s	0 to 2			RO
27	Chilled Flow Status 0=Fail or Not Started 1=Success, 2=Verifying	chw_fl_s	0 to 2			RO
28	Pumpdown/Lockout State	pdown_st	0 to 255			RO

LEGEND

RO — Read Only

RW — Read/Write

*Default value is shown only if configurable in this table.

APPENDIX A — PIC 6 SCREEN AND TABLE STRUCTURE (cont)

Run Times

CCN TABLE NAME: RUNTIME

PIC 6 PATH: Main Menu → Run Times

LINE	PIC 6 DESCRIPTION	CCN NAME	RANGE	DEFAULT VALUE*	UNIT	READ/WRITE
1	Starts in 12 Hours	ST_CNT12	0 to 8			RO
2	Compressor Starts Num	C_STARTS	0 to 99999			RO
3	Compressor Running Hrs	COMP_HRS	0 to 500000.0		hr	RO
4	After Service Hrs	SRV_HRS	0 to 500000.0	0.0	hr	RW
5	Stop to Start Timer	spst_tim	1.0 to 15.0		min	RO
6	Start to Start Timer	stst_tim	4.0 to 45.0		min	RO
7	Oil Lubrication Duration	oilb_dur	1000 to 8000		hr	RO
8	Oil Storage Duration	oils_dur	5000 to 15000		hr	RO
9	Recy Startup in 4 Hours	RCYSTCNT	0 to 6			RO
10	Swift Restarts in 1 Hour	SWIFTCNT	0 to 4			RO

LEGEND

RO — Read Only
RW — Read/Write

NOTE: The displayed runtime is updated every hour. To avoid the loss of data in case of disruption, the values are backed up.

*Default value is shown only if configurable in this table.

Modes

CCN TABLE NAME: MODES

PIC 6 PATH: Main Menu → Modes

LINE	PIC 6 DESCRIPTION	CCN NAME	RANGE	DEFAULT VALUE*	UNIT	READ/WRITE
1	Normal Shutdown	shut_nor	NO/YES			RO
2	Recycle Shutdown	shut_rcy	NO/YES			RO
3	Alarm Shutdown	shut_alm	NO/YES			RO
4	Recycle Startup	str_rcy	NO/YES			RO
5	Temperature Ramping	tmp_ramp	NO/YES			RO
6	Load Ramping	ld_ramp	NO/YES			RO
7	IGV1 Inhibiting	gv1_inh	NO/YES			RO
8	Ice Building	ice_act	NO/YES			RO
9	Ice Build Terminated	ice_term	NO/YES			RO
10	Ice Build Recy Startup	ice_rcy	NO/YES			RO
11	Ramp Loading	ramp_act	NO/YES			RO
12	Demand Limit	dem_act	NO/YES			RO
13	VFD Rampdown	vfdrpact	NO/YES			RO
14	Demand Limit Inhibit	dem_inh	NO/YES			RO
15	Evaporator Frozen	evapfrze	NO/YES			RO
16	Condenser Frozen	condfrze	NO/YES			RO
17	Recycle Shutdown Done	rcysh_cm	NO/YES			RO
18	NonRecycle Shutdown Done	nrysh_cm	NO/YES			RO
19	In Alarm	alm_act	NO/YES			RO
20	In Override	over_act	NO/YES			RO
21	Comp1 Run State Val	cm_stat1	0 to 13			RO

LEGEND

RO — Read Only

*Default value is shown only if configurable in this table.

Setpoint

CCN TABLE NAME: SETPOINT

PIC 6 PATH: Main Menu → Setpoint

LINE	PIC 6 DESCRIPTION	CCN NAME	RANGE	DEFAULT VALUE*	UNIT	READ/WRITE
1	Cooling ECW Setpoint	ecw_sp	15.0 to 120.0	60.0	°F	RW
2	Cooling LCW Setpoint	lcw_sp	10.0 to 120.0	45.0	°F	RW
3	Heating ECDW Setpoint	ecdw_sp	63.0 to 150.0	104.0	°F	RW
4	Heating LCDW Setpoint	lcdw_sp	68.0 to 150.0	113.0	°F	RW
5	Ice Build Setpoint	ice_sp	15.0 to 60.0	40.0	°F	RW
6	Base Limit Demand	dem_base	10.0 to 100.0	100.0	%	RW
7	EWT Control Option	EWT_OPT	DSABLE/ENABLE	DSABLE		RW

LEGEND

RW — Read/Write

*Default value is shown only if configurable in this table.

APPENDIX A — PIC 6 SCREEN AND TABLE STRUCTURE (cont)

Configuration Menu

Navigation: MAIN MENU → CONFIGURATION MENU

ICON	DISPLAYED TEXT	ACCESS	ASSOCIATED TABLE	PAGE NO.
	Service Parameters	Service	SERVICE1	68
	Surge Correction	Service	CFGSURGE	68
	Protective Limit	Service	CFGLIMIT	69
	Lab Test Forced	Service	LABONLY	Factory only
	Option Configuration	Service	CONF_OPT	70
	Option2	Service	CONF_OPT2	70
	VFD Parameters	Service	CFGUMVFD	71
	ISM	Service	CONF_ISM	72
	Modbus Master	Service	CFGMBMST	71
	Factory Parameter	Factory	FACTORY	73
	General	User	GEN_CONF	73
	Control Identification	User	CTRL_ID	Info. only
	General VFD	Service	CFGGEVFD	73
	SRD	Service	CONF_SRD	74
	IOB	Service	CONF_IOB	74
	Master Slave Config	Service	CONF_MS	75
	Prognostics	Service	CONF_PRG	75
	Temperature	User	RESETCFG	76
	Schedule Menu	User	SCHEDULE	76
	Holiday Menu	User	HOLIDAY	77
	Broadcast Menu	User	BROADCAST	77
	BMS Protocol	Service	CONNECT	78
	VFD Line Param Calib	Service	VFD_EFF	79
	Low Load	Service	LQBP	79

APPENDIX A — PIC 6 SCREEN AND TABLE STRUCTURE (cont)

Service Parameters

CCN TABLE NAME: SERVICE1						
PIC 6 PATH: Main Menu → Configuration Menu → Service Parameters						
LINE	PIC 6 DESCRIPTION	CCN NAME	RANGE	DEFAULT VALUE*	UNIT	READ/WRITE
1	Atmospheric Pressure	atom_pre	8 to 15	14.5	psi	RW
2	GV1 Travel Limit	gv1_lim	30 to 100	80	%	RW
3	GV1 Closure at Startup	gv1stpos	0 to 40	4	%	RW
4	Controlled Fluid DB	ctrl_db	0.5 to 2.0	1.0	°F	RW
5	Derivative EWT Gain	ewtdgain	1.0 to 3.0	2.0		RW
6	Proportional Dec Band	gv1decdb	2.0 to 10.0	6.0		RW
7	Proportional Inc Band	gv1incdb	2.0 to 10.0	6.5		RW
8	Maximum GV Movement	max_gv	2.0 to 4.0	2.0	%	RW
9	Demand Limit At 20 mA	dem_20ma	10 to 100	40	%	RW
10	Demand Limit Prop Band	dem_pdb	3.0 to 15.0	10.0	%	RW
11	Amps or KW Ramp per Min	ldramprt	5 to 20	10	%	RW
12	Temp Ramp Rate per Min	tmramprt	1 to 10	3	°F	RW
13	Recycle Shutdown Delta T	rcysh_dt	0.5 to 4.0	1.0	°F	RW
14	Recycle Restart Delta T	rcyst_dt	2.0 to 10.0	5.0	°F	RW
15	Damper Valve Act Delay	dmp_dly	0 to 20	5	min	RW
16	Damper Valve Close DB	dmp_cldb	2.0 to 10.0	5.0	psig	RW
17	Damper Valve Open DB	dmp_opdb	10.0 to 20.0	13.0	psig	RW
18	Damper Action Delta T	dmp_dt	4.0 to 10.0	7.0	°F	RW
19	Lub Press Verify Time	oilpvr_t	15 to 300	40	sec	RW
20	Soft Stop Amps Threshold	sf_st_th	40 to 100	70	%	RW
21	Water Flow Verify Time	wflow_t	0.5 to 5.0	5.0	min	RW
22	Power Calibration Factor	mbb_pfcl	0.900 to 1.000	0.970		RW
23	Enable Excessive Starts	ex_start	YES/NO	NO		RW
24	Oil Stir Cycle (19XR6/7) 0 = No stir, 1 = 30s/30m, 2 = 1m/4hr, 3 = Comb 0&1	oilstiro	0 to 3	1		RW

Surge Correction

CCN TABLE NAME: CFGSURGE						
PIC 6 PATH: Main Menu → Configuration Menu → Surge Correction						
LINE	PIC 6 DESCRIPTION	CCN NAME	RANGE	DEFAULT VALUE*	UNIT	READ/WRITE
1	Surge Line Configuration 0=PR, 1=Delta T	sgl_cfg	0 to 1	0		RW
2	IGV1 Pos Configuration 0-Degree, 1=Percentage	gv1c_sel	0 to 1	0		RW
3	Surge Delta Tmax	dt_max	0.0 to 150.0	70.0	°F	RW
4	Surge Delta Tmin	dt_min	0.0 to 150.0	45.0	°F	RW
5	PR at Full Load Opening	pr_ful	1.0000 to 5.0000	3.0000		RW
6	PR at Min. Opening	pr_min	1.0000 to 5.0000	1.5000		RW
7	IGV1 Full Load Open Deg	gv1_dful	90 to 120.0	88.0	degree	RW
8	Sound Ctrl IGV1 Open Deg	gv1_dmed	10.0 to 40.0	27.0	degree	RW
9	IGV1 Minimum Open Deg	gv1_dmin	0.0 to 10.0	2.0	degree	RW
10	IGV1 Actuator Max Deg	gv1_dmax	90.0 to 120.0	109.0	degree	RW
11	Surge Line Offset	sgl_off	1.0 to 3.0	2.0	°F	RW
12	Surge Line Lower Deadband	sql_hoff	0.5 to 3.0	1.5	°F	RW
13	Surge Line Upper Deadband	sql_hoff	0.1 to 3.0	1.5	°F	RW
14	Surge Line Shape Factor	sgl_shfh	-1.000 to 0.000	-0.010		RW
15	Sound Line Shape Factor	sgl_shfl	0.000 to 1.000	0.010		RW
16	Surge Line Speed Factor	sgl_spdf	0.00 to 3.00	2.00		RW
17	Surge Delay Time	surg_del	0 to 120	15	sec	RW
18	Surge Time Period	surge_t	7 to 10	8	min	RW
19	Surge Delta Amps %	surge_a	5 to 40	20	%	RW
20	Rampdown Factor	rd_fact	0 to 1	0.1		RW
21	GV1 Close Step Surge	gvstp_sg	1.0 to 3.0	2.0	%	RW
22	VFD Speed Step Surge	vfdstpsg	1.0 to 5.0	1.5	%	RW
23	EC/HG Valve Step Surge	hbpstsg	1.0 to 10.0	4.0	%	RW
24	Surge Profile Offset	sgl_pro	0.0 to 5.0	0.0	°F	RW
25	High Efficiency Mode	high_eff	DSABLE/ENABLE	DSABLE		RW
26	GV Jumpover	gv_skip	DSABLE/ENABLE	DSABLE		RW

LEGEND

RW — Read/Write

*Default value is shown only if configurable in this table.

APPENDIX A — PIC 6 SCREEN AND TABLE STRUCTURE (cont)

Protective Limit Config

CCN TABLE NAME: CFGLIMIT

PIC 6 PATH: Main Menu → Configuration Menu → Protective Limit Config

LINE	PIC 6 DESCRIPTION	CCN NAME	RANGE	DEFAULT VALUE*	UNIT	READ/WRITE
1	Evap Approach Alert	evap_al	0.5 to 15	5	°F	RW
2	Cond Approach Alert	cond_al	0.5 to 15	6	°F	RW
3	Cond Press Override Low	cpov_lo	90 to 157	140	psig	RW
4	Cond Press Override High	cpov_hi	200 to 265	250	psig	RW
5	Cond Press Cutout Low	cpcut_lo	155 to 160	160	psig	RW
6	Cond Press Cutout High	cpcut_hi	270 to 275	275	psig	RW
7	Evap Override Delta T	ert_ovdt	2 to 5	3	°F	RW
8	Evap Refrig Trippoint	ert_trip	0 to 40	33	°F	RW
9	High Evap Press Override	ep_ov	90 to 157	140	psig	RW
10	High Evap Press Cutout	ep_cut	160 to 170	165	°F	RW
11	Condenser Freeze Point	cdfreeze	-20.0 to 35.0	34.0	°F	RW
12	Comp Discharge Alert	dgt_alrt	125 to 200	200	°F	RW
13	Comp Motor Temp Override	mt_over	150 to 200	200	°F	RW
14	Comp Bearing Temp Alert	tb_alert	155 to 175	175	°F	RW
15	Comp Bearing Temp Trip	tb_trip	175 to 185	185	°F	RW
16	Comp Bearing Alert XR6/7	tb_alt2	185 to 210	210	°F	RW
17	Comp Bearing Trip XR6/7	tb_trip2	210 to 220	220	°F	RW
18	Minimum Brine LWT	bri_min	10 to 34	34	°F	RW
19	Heating LWT Protect Set	lwtp_sp	41 to 50	42.8	°F	RW
20	Evap Flow Delta P Cutout	evap_cut	0.5 to 50	5	psig	RW
21	Cond Flow Delta P Cutout	cond_cut	0.5 to 50	5	psig	RW
22	Cond Hi Flow DP Limit	cond_val	0.5 to 50	50	psig	RW
23	Cond Hi Flow Alarm	cond_alm	DSABLE/ENABLE	DSABLE		RW
24	Inverter Temp Override	inv_ov	100 to 400	200	°F	RW

LEGEND

RW — Read/Write

*Default value is shown only if configurable in this table.

APPENDIX A — PIC 6 SCREEN AND TABLE STRUCTURE (cont)

Option

CCN TABLE NAME: CONF_OPT

PIC 6 PATH: Main Menu → Configuration Menu → Option

LINE	PIC 6 DESCRIPTION	CCN NAME	RANGE	DEFAULT VALUE*	UNIT	READ/WRITE
1	Auto Restart Option	astart	DSABLE/ENABLE	DSABLE		RW
2	Swift Restart Option	swstart	DSABLE/ENABLE	DSABLE		RW
3	Gas Torque Factore	gt_fact	0.25 to 3.00	1.0		RW
4	Guide Vane/SRD Factor		0.7 to 1.2	0.95		RW
5	Power Recovery Timeout		0 to 60	15	min	RW
6	Common Sensor Option	commsens	DSABLE/ENABLE	DSABLE		RW
7	EC/HG Valve Option 0 = No, 1 = Cont 2 = On/Off, 3 = 4-20 mA	hgbp_opt	0 to 3	0		RW
8	EC/HG Valve Selection 0 = Disable, 1 = Surge 2 = Low Load, 3 = Comb	hgbp_sel	0 to 3	0		RW
9	EC/HG VLV Open IGV1 Pos	hpop_gv1	0.5 to 10	5.0	%	RW
10	EC/HG VLV Close IGV1 Pos	hgcl_gv1	1.5 to 20	10.0	%	RW
11	EC/HG VLV Low Load DB	hgbp_ldb	0.5 to 2.0	1.0	^F	RW
12	HPR VLV Option	hdpv_opt	DSABLE/ENABLE	DSABLE		RW
13	HPR VLV Delta Pos 0%	hdp_0	20.0 to 85.0	25.0	psig	RW
14	HPR VLV Delta Pos 100%	hdp_100	20.0 to 85.0	50.0	psig	RW
15	HPR VLV Min Output	hdpv_min	0.0 to 100.0	0.0	%	RW
16	HPR VLV Deadband,	hdpv_db	0-10	1		RW
17	Tower Fan High set point	tfh_sp	55 to 105	75		RW
18	Refrigerant Leak Option	leak_en	DSABLE/ENABLE	DSABLE		RW
19	Refrig Leakage Alarm mA	exv_opt	4 to 20	20		RW
20	Oil EXV Option	leak_ma	DSABLE/ENABLE	DSABLE	mA	RW
21	Oil Temp High Threshold	oil_high	100 to 140	120	°F	RW
22	Oil Temp Low Threshold	oil_low	90 to 130	110	°F	RW
23	Customer Alert Option	cusa_opt	DSABLE/ENABLE	DSABLE		RW
24	Ice Build Option	ice_opt	DSABLE/ENABLE	DSABLE		RW
25	Ice Build Recycle	ice_recy	DSABLE/ENABLE	DSABLE		RW
26	Ice Build Termin Source 0 = Temp, 1 = Contact, 2 = Both	ice_term	0 to 2	0		RW
27	Vapor Source SV Delay	vssv_dly	0-10	5.0	min	RW
28	Max Oil Pressure Diff	opvfdmax	35-60	50	PSI	RW
29	Oil Pump VFD Max Step	opvfdstp	0-10	7	%	RW
30	Vapor Source SV Delay	vssv_dly	0-10	5	min	RW
31	Vapor Source SV Option	vssv_dly	DSABLE/ENABLE	DSABLE		RW
32	Evap Liquid Temp Opt	evap_ref	DSABLE/ENABLE	Enable		
33	Evap App Calc Selection Sat Temp = 0, Ref Temp = 1	evap_ref	0/1	1		RW

LEGEND

*Default value is shown only if configurable in this table.

RW — Read/Write

Option2

CCN TABLE NAME: CONFOPT2

PIC 6 PATH: Main Menu → Configuration Menu → Option 2

LINE	PIC 6 DESCRIPTION	CCN NAME	RANGE	DEFAULT VALUE*	UNIT	READ/WRITE
1	IOB3 Option	iob3_opt	No/Yes	Yes		
2	IOB4 Option	iob4_opt	No/Yes	No		
3	Free Cooling Option	freecool	No/Yes	No		
4	Water Pressure Option 0=No, 1=WTR Flow PD TRD, 2=WTR Flow PD MTR	wp_opt	0-2	0		RW
5	Water Flow Measurement 0 = No, 1 = WTR Flow MTR, 2 = WTR Flow PD	wfm_opt	0-2	0		RW
6	Water Flow Determination 0=Sat Temp, 1=Flow Switch, 2= WTR Flow PD	fs_opt	0-1	0		RW
7	Water Flow at 4 mA	flow4ma	0-12000	0.00	GPM	RW
8	Water Flow at 20 mA	flow20ma	0-12000	0.00	GPM	RW
9	Water Pres Drop at 20 mA	wpd_20ma	0-40	10.00	PSI	RW
10	Evap Flow Rate Baseline	chwf_bas	0-9000	0.00	GPM	RW
11	Evap Pres Drop Baseline	evpd_bas	0-20	0.00	PSI	RW
12	Cond Flow Rate Baseline	cdwf_bas	0-9000	0.00	GPM	RW
13	Cond Pres Drop Baseline	cdpd_bas	0-20	0.00	PSI	RW
14	Marine Option	mrn_opt	DSABLE/ENABLE	DSABLE		RW

LEGEND

*Default value is shown only if configurable in this table.

RW — Read/Write

APPENDIX A — PIC 6 SCREEN AND TABLE STRUCTURE (cont)

VFD Parameters

CCN TABLE NAME: CFGUMVFD

PIC 6 PATH: Main Menu → Configuration Menu → VFD Parameters

LINE	PIC 6 DESCRIPTION	CCN NAME	RANGE	DEFAULT VALUE*	UNIT	READ/WRITE
1	Compressor Speed 100%	comp_hz	47 to 110	50	Hz	RW
2	Rated Line Voltage	rlv_i	200-13800	460	V	RW
3	Motor Nameplate Current	rla	10 to 1500	200	AMPS	RW
4	Motor Rated Load Current	rla_load	10 to 2000	200	AMPS	RW
5	Motor Nameplate Voltage	rlv	200 to 13800	460	Volts	RW
6	Motor Nameplate RPM	rpm	1500 to 3600	3000	rpm	RW
7	Motor Nameplate KW	rlkw	0 to 5600	1500	KW	RW
8	Skip Frequency 1	skipfrq1	0.0 to 102.0	102	Hz	RW
9	Skip Frequency 2	skipfrq2	0.0 to 102.0	102	Hz	RW
10	Skip Frequency 3	skipfrq3	0.0 to 102.0	102	Hz	RW
11	Skip Frequency Band	skipband	0.0 to 102.0	0	Hz	RW
12	Motor Rated Load Current	rla_load	10 to 1500	200	AMPS	RW
13	Increase Ramp Time	ramp_inc	5 to 60	30	sec	RW
14	Decrease Ramp Time	ramp_dec	5 to 60	30	sec	RW
15	Line Voltage Imbalance%	lvim_th	1 to 10	10	%	RW
16	Line Volt Imbalance Time	lvim_per	1 to 10	10	sec	RW
17	Line Current Imbalance%	lcim_th	5 to 40	40	%	RW
18	Line Current Imbal Time	lcim_per	1 to 10	10	sec	RW
19	Motor Current Imbalance%	mcim_th	5 to 40	40	%	RW
20	Motor Current Imbal Time	mcim_per	1 to 10	10	sec	RW
21	Single Cycle Dropout	scycd_en	0 to 1	0		RW
22	PWM Switch Frequency 0=2KHZ, 1=4KHZ	pwm_freq	0 to 1	0		RW
23	Restore Defaults	res_def	0 to 1	0		RW
24	LEN Comm Timeout	com_tout	0 to 255	10	sec	RW
25	Modbus Comm Timeout	mod_tout	0 to 255	2	sec	RW
26	Gateway Modbus Baud Rate 4800=1, 9600=2, 19200=3, 38400=4	gw_baud	1 to 4	2		RW

Modbus Master

CCN TABLE NAME: CFGMBMST

PIC 6 PATH: Main Menu → Configuration Menu → Modbus Master

LINE	PIC 6 DESCRIPTION	CCN NAME	RANGE	DEFAULT VALUE*	UNIT	READ/WRITE
1	Modbus Gateway Option 0=Native, 1=Gateway	mm_gw	0 to 1	0		RW
2	Modbus Board Comm Timeout	com_tout	0 to 255	10	sec	RW
3	Modbus Comm Timeout	mod_tout	0 to 255	2	sec	RW
4	Modbus Baud Rate 1=4800, 2=9600, 3=19,200, 4=38,400	gw_baud	1 to 4	2		RW
5	Slave Device 1 Address	mm_addr1	0 to 255	0		RW
6	Slave Device 2 Address	mm_addr2	0 to 255	0		RW
7	Slave Device 3 Address	mm_addr3	0 to 255	0		RW
8	Slave Device 4 Address	mm_addr4	0 to 255	0		RW
9	Slave Device 5 Address	mm_addr5	0 to 255	0		RW

LEGEND

RW — Read/Write

*Default value is shown only if configurable in this table.

APPENDIX A — PIC 6 SCREEN AND TABLE STRUCTURE (cont)

ISM Configuration

CCN TABLE NAME: CONF_ISM

PIC 6 PATH: Main Menu → Configuration Menu → ISM Configuration

LINE	PIC 6 DESCRIPTION	CCN NAME	RANGE	DEFAULT VALUE*	UNIT	READ/WRITE
1	Communication Timeout	com_tout	0 to 255	10	sec	RW
2	Starter Type 0 = Full Volt, 1 = Reduced Volt 2 = Solid State, 3 = FS VFD	star_typ	0 to 3	0		RW
3	Single Cycle Dropout	scycd_en	DSABLE/ENABLE	DSABLE		RW
4	Motor Rated Load Amps	rla	10 to 5000	200	amp	RW
5	Motor Rated Kilowatts	rkw	1000 to 8000	1500	kW	RW
6	Motor Locked Rotor Trip	mot_lra	100 to 65535	1000	amp	RW
7	Locked Rotor Start Delay	lrs_del	1 to 10	5	cycles	RW
8	Starter LRA Rating	str_lra	100 to 65535	2000	amp	RW
9	Motor Rated Line Voltage	rlv	200 to 13800	460	V	RW
10	Current Imbal Threshold	cu_th	5 to 100	15	%	RW
11	Voltage Imbal Threshold	vu_th	1 to 10	5	%	RW
12	Motor Current CT Ratio:1	ct_ratio	3 to 1000	100		RW
13	Volt Transformer Ratio:1	vt_rat	1 to 115	1		RW
14	Current Imbal Persist	cu_per	1 to 10	5	sec	RW
15	Voltage Imbal Persist	vu_per	1 to 10	5	sec	RW
16	Line Frequency Faulting	lref_en	DSABLE/ENABLE	DSABLE		RW
17	Frequency (NO=50 Hz, YES=60 Hz)	linefreq	NO/YES	NO		RW
18	Ground Fault Protection	gfp_en	DSABLE/ENABLE	ENABLE		RW
19	Ground Fault Current	gf_amps	1 to 25	15	amp	RW
20	Ground Fault Persistence	gfp_pers	1 to 10	5	cycles	RW
21	Ground Fault Start Delay	gfs_del	1 to 20	10	cycles	RW
22	Ground Fault CT Ratio:1	gfct_rat	150 to 150	150		RW
23	Overvoltage Threshold	ovvol_th	105 to 115	115	%	RW
24	Undervoltage Threshold	udvol_th	85 to 95	85	%	RW
25	Over Under Volt Persist	ovud_per	1 to 10	5	sec	RW
26	Under Volt Start Delay	uvs_del	1 to 4	1	sec	RW

LEGEND

RW — Read/Write

*Default value is shown only if configurable in this table.

APPENDIX A — PIC 6 SCREEN AND TABLE STRUCTURE (cont)

Factory Parameters

CCN TABLE NAME: FACTORY

PIC 6 PATH: Main Menu → Configuration Menu → Factory Parameters

LINE	PIC 6 DESCRIPTION	CCN NAME	RANGE	DEFAULT VALUE*	UNIT	READ/WRITE
1	Chiller Type 0=19XR6/7, 1=19XR2-5/E/D/V, 2 = 19DV, 3=19XRF	chil_typ	0 to 3	0		RW
2	VFD/Starter Option† 0 = No, 1 = FS FVD, 2 = UM VFD, 3 = Rockwell LF2, 4 = EATON, 5 = Rockwell Std Tier, 6=ABB, 7=Danfoss, 8=Benshaw, 9=STEP HV VFD	vfd_opt	0 to 9	0		RW
3	Unit Type 0 = Cool Only, 1 = Heat Machine	unit_typ	0 to 1	0		RW
4	Refrigerant Type (Non 19DV) 0 = R134a, 1 = R513a, 2= R515a	refg_typ	0 to 2	0		RW
5	Comp 0 = Single, 1 = Dual Single refers to single stage compressor (19XR2,3,4,5). Dual (19XRC,E,6,7 and 19DV)	comp_typ	0 to 1	1		RW
6	Chilled Medium Type	chmedium	WATER/BRINE	WATER		RW
7	Cond Shell Side MAWP 0=185 psi, 1=300 psi	cond_typ	0 to 1	0		RW
8	Country Code (Country Code = 1 for USA)	coun_cod	0 to 500	86		RW
9	Guide Vane1 Type 0=Digital, 1=Analog	gv1_type		0		RW
10	Heat Reclaim Option 0=No, 1=Full, 2=Partial	hr_opt	YES/NO	NO		RW

LEGEND

RW — Read/Write

* Default value is shown only if configurable in this table.

† While Benshaw is not a VFD option, the MX3 option (without ISM card) is configured here.

General Configuration

CCN TABLE NAME: GEN_CONF

PIC 6 PATH: Main Menu → Configuration Menu → General Configuration

LINE	PIC 6 DESCRIPTION	CCN NAME	RANGE	DEFAULT VALUE*	UNIT	READ/WRITE
1	Stop to Start Delay	min_off	1 to 15	2	min	RW
2	Start to Start Delay	strt_dly	4 to 45	15	min	RW
3	Demand Limit Type 0 = Base Demand, 1 = 4 to 20 mA	dem_sel	0 to 1	0		RW
4	Pulldown Ramp Type 0 = Temp, 1 = Load	ramp_slct	0 to 1	1		RW
5	Demand Limit Source 0 = amps, 1 = kW	DEM_SLCT	0 to 1	0		RW

LEGEND

RW — Read/Write

* Default value is shown only if configurable in this table.

General VFD

Freestanding VFD

CCN TABLE NAME: CFGGEVFD

PIC 6 PATH: Main Menu → Configuration Menu → General VFD

LINE	PIC 6 DESCRIPTION	CCN NAME	RANGE	DEFAULT VALUE*	UNIT	READ/WRITE
1	VFD Gain	vfd_gain	0.10 to 1.50	0.75		RW
2	VFD Max Speed Per	vfd_max	90.0 to 110.0	100.0	%	RW
3	VFD Min Speed Per	vfd_min	65.0 to 100.0	70.0	%	RW
4	VFD Start Speed Per	vfd_str	65.0 to 100.0	100.0	%	RW
5	VFD Current Limit	vfdculm	0.0 to 99999.0	250	amp	RW

LEGEND

RW — Read/Write

* Default value is shown only if configurable in this table.

APPENDIX A — PIC 6 SCREEN AND TABLE STRUCTURE (cont)

SRD

CCN TABLE NAME: CONF_SRD

PIC 6 PATH: Main Menu → Configuration Menu → SRD

LINE	PIC 6 DESCRIPTION	CCN NAME	RANGE	DEFAULT VALUE*	UNIT	READ/WRITE
1	Diffuser Option	diff_opt	DSABLE/ENABLE	DSABLE		RW
2	SRD IGV Offset Select	off_sel	1 to 5	3		RW
3	Low Lift Profile Select	pro_sel	1 to 5	3		RW
4	Diffuser Full Span mA	diff_ma	15.0 to 22.0	18.0	mA	RW
5	GV1 Pos @ 25% Load	gv11_25	0.0 to 83.0	6.4	%	RW
6	GV1 Pos @ 50% Load	gv11_50	0.0 to 83.0	22.9	%	RW
7	GV1 Pos @ 75% Load	gv11_75	0.0 to 83.0	41.3	%	RW
8	SRD Pos @ 25% Load	sr11_25	0.0 to 100.0	73.5	%	RW
9	SRD Pos @ 50% Load	sr11_50	0.0 to 100.0	35.1	%	RW
10	SRD Pos @ 75% Load	sr11_75	0.0 to 100.0	19.5	%	RW
11	High Lift Load @ 100%	lf1_100	0.0 to 100.0	67.5	°F	RW
12	High Lift Load @ 25%	lf1_25	0.0 to 100.0	52.4	°F	RW
13	Low Lift Load @ 25%	lf2_25	0.0 to 100.0	27.2	°F	RW

LEGEND

RW — Read/Write

*Default value is shown only if configurable in this table.

IOB

CCN TABLE NAME: CONF_IOB

PIC 6 PATH: Main Menu → Configuration Menu → IOB

LINE	PIC 6 DESCRIPTION	CCN NAME	RANGE	DEFAULT VALUE*	UNIT	READ/WRITE
1	Sensor Type Option: 0=Disable, 1=Volt, 2=mA, 3=10K Ohm Thermistor, 4=5K Ohm Thermistor, 5= Resistance, 6=RTD					
2	ECW Sensor Type	typ_ai11	0-6	4		RW
3	LCW Sensor Type	typ_ai12				
4	ECDW Sensor Type	typ_ai13				
5	LCDW Sensor Type	typ_ai14				
6	MTRW1 Sensor Type	typ_ai21				
7	MTRW2 Sensor Type	typ_ai22				
8	MTRW3 Sensor Type	typ_ai23				
9	ISM Input	ismin_en	DSABLE/ENABLE	DSABLE		RW
10	Peak Detection Threshold	peak_th	0.0000 to 5.0000	0.0000	Volts	RW
11	ISM Input Enable	ismin_en	DSABLE/ENABLE	DSABLE		RW

LEGEND

RW — Read/Write

*Default value is shown only if configurable in this table.

APPENDIX A — PIC 6 SCREEN AND TABLE STRUCTURE (cont)

Master Slave Configuration

CCN TABLE NAME: CONF_MS

PIC 6 PATH: Main Menu → Configuration Menu → Master Slave Config

LINE	PIC 6 DESCRIPTION	CCN NAME	RANGE	DEFAULT VALUE*	UNIT	READ/WRITE
1	Slave Address	slv_addr	1 to 236	2		RW
2	Master/Slave Select 0=Disable, 1=Master, 2=Slave	mssl_sel	0 to 2	0		RW
3	Chiller Connection Type 0=Parallel, 1=Series	ms_type	0 to 1	0		RW
4	Middle Sensor Option	mids_opt	YES/NO	YES		RW
5	Master Lead/Lag Select 0=Lead change to Lag Once Failed 1=Runtime Balance	lead_sel	0 to 1	0		RW
6	Series Counter Flow	serct_fl	YES/NO	NO		RW
7	Take Over On Comm Los	toocl	DSABLE/ENABLE	DSABLE		RW
8	Master per Capacity	ms_per	25 to 75	50	%	RW
9	LAG Shutdown Threshold	lag_shut	25 to 75	50	%	RW
10	Prestart Fault Time	pref_tim	2 to 30	5	min	RW
11	Lead Unload Threshold		50 to 100	100	%	RW
12	Lead/Lag Balance Delta	ll_bal_d	40 to 400	168	hr	RW
13	Lag Start Time	lstr_tim	2 to 30	10	min	RW
14	Lag Stop Time	lstp_tim	2 to 30	10	min	RW
15	Lead Pulldown Time	lead_pul	0 to 60	0	min	RW
16	Lag Minimum Run Time	lag_mini	0 to 150	0	min	RW
17	Lag Run Delta T	lagrundt	0 to 10.0	3.0	^F	RW
18	Lag Off Delta T	lagoffdt	0 to 10.0	1.8	^F	RW

Prognostics Config

CCN TABLE NAME: CONF_PRG

PIC 6 PATH: Main Menu → Configuration Menu → Prognostics Config

LINE	PIC 6 DESCRIPTION	CCN NAME	RANGE	DEFAULT VALUE*	UNIT	READ/WRITE
1	Prog Function Enable	prog_en	YES/NO	NO		RW
2	Oil Change Done	oilch_cm	YES/NO	YES		RW
3	Oil Filter Change Done	oilfc_cm	YES/NO	YES		RW
4	Trans Calibration Done	tracl_cm	YES/NO	YES		RW
5	Refrigerant Charge Done	refch_cm	YES/NO	YES		RW
6	Oil Filter PD Threshold	oiifl_th	-6.7 to 420	10	psig	RW
7	Oil Lub Expire Time	oilch_nt	1000.0 to 8000.0	2000.0	hr	RW
8	Oil Storage Expire Time	oilst_nt	5000.0 to 15000.0	8640	hr	RW
9	Trans Calib Threshold	refgc_th	0 to 5	2	psig	RW
10	Low Charge Cond Approach	rch_cath	20 to 40	20	°F	RW
11	Evap Design Approach	ep_dgap	0 to 10	3	°F	RW
12	Bearing Degradation	bearth_th	100 to 230	200	°F	RW
13	Oil Quality	oil_qly	0-2	0		RW
14	Oil Filter Failure	oil_ft	0-2	0		RW
15	Transducer Deviation	tran_dev	0-2	0		RW
16	Refrig Charge Status	ref_chg	0-2	0		RW

LEGEND

RW — Read/Write

*Default value is shown only if configurable in this table.

APPENDIX A — PIC 6 SCREEN AND TABLE STRUCTURE (cont)

Temperature Reset

CCN TABLE NAME: RESETCFG

PIC 6 PATH: Main Menu → Configuration Menu → Temperature Reset

LINE	PIC 6 DESCRIPTION	CCN NAME	RANGE	DEFAULT VALUE*	UNIT	READ/WRITE
1	Temp Reset Type 0 = No, 1 = 4 to 20 mA 2 = Remote Temp, 3 = Water DT [delta temperature]	res_sel	0 to 3	0		RW
2	Degrees Reset At 20 mA	der_20ma	-30.0 to 30.0	10.0	°F	RW
3	Maximum Deg Temp Reset	deg_rset	-30.0 to 30.0	10.0	°F	RW
4	Remote Temp Full Reset	remtm_fu	-40.0 to 245.0	65.0	°F	RW
5	Remote Temp No Reset	remtm_no	-40.0 to 245.0	85.0	°F	RW
6	Deg Reset Water DT Full	drwdt_fu	-30.0 to 30.0	10.0	°F	RW
7	Controlled DT Full Reset	ctldt_fu	0.0 to 15.0	0.0	°F	RW
8	Controlled DT No Reset	ctldt_no	0.0 to 15.0	10.0	°F	RW



LEGEND

*Default value is shown only if configurable in this table.

RW — Read/Write

Schedule Menu

Navigation: MAIN MENU → CONFIGURATION MENU → SCHEDULE MENU

ICON	DISPLAYED TEXT	ACCESS	ASSOCIATED TABLE
	Local Schedule	User	
	Ice Build Schedule	User	
	Network Schedule	User	

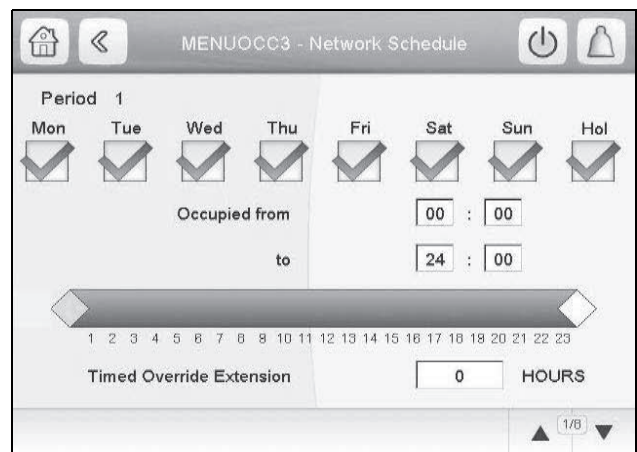
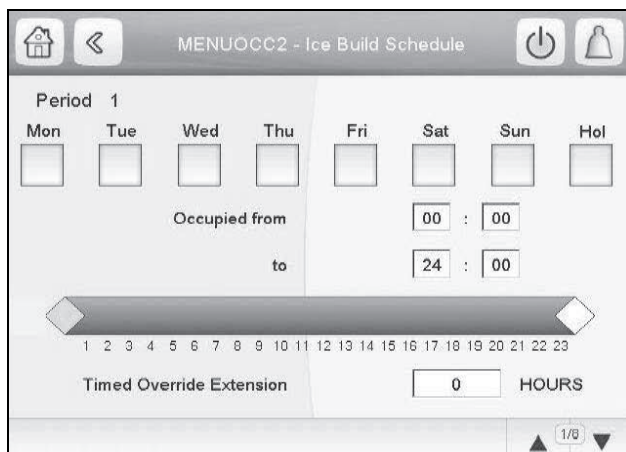
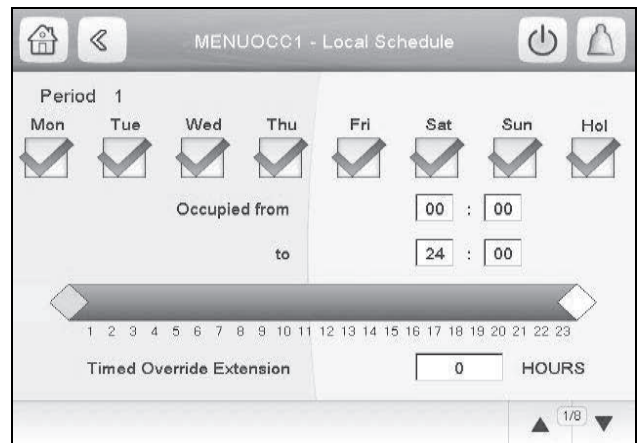
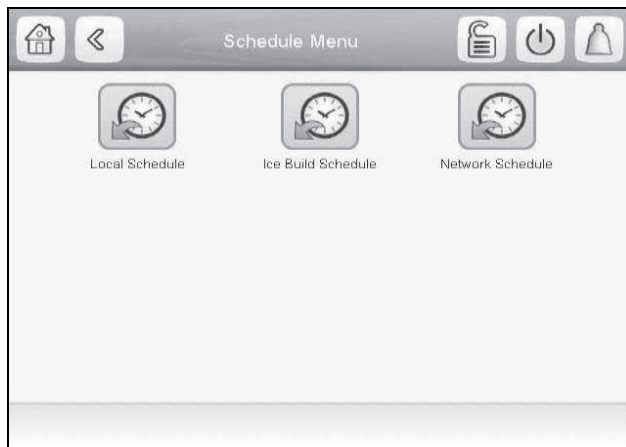

Fig. B — Schedule Menu and Submenus

APPENDIX A — PIC 6 SCREEN AND TABLE STRUCTURE (cont)

Holiday Menu

Navigation: **MAIN MENU** → **CONFIGURATION MENU** → **HOLIDAY MENU**

The Holiday Menu has 16 submenus (HOLDY-01 to HOLDY_16), so it is possible to set 16 different holiday periods. For more information about holiday periods, see the Time Schedule section on page 33. Figure C below shows the Holiday Menu and a sample submenu.

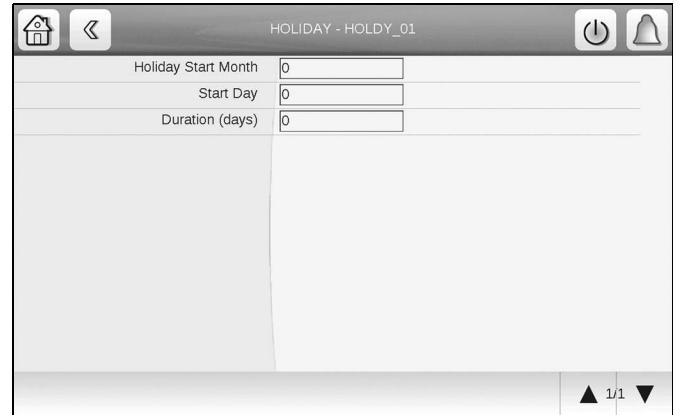
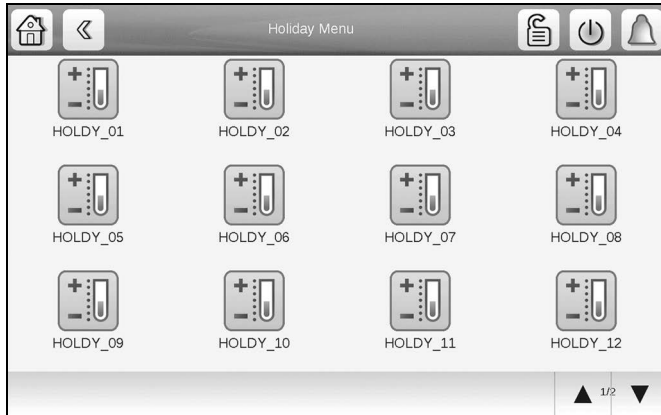

Fig. C — Holiday Menu and Submenu

Broadcast Menu

Navigation: **MAIN MENU** → **CONFIGURATION MENU** → **BROADCAST MENU**

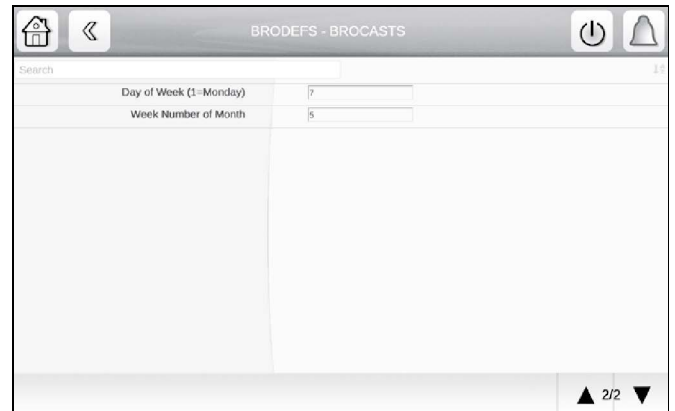
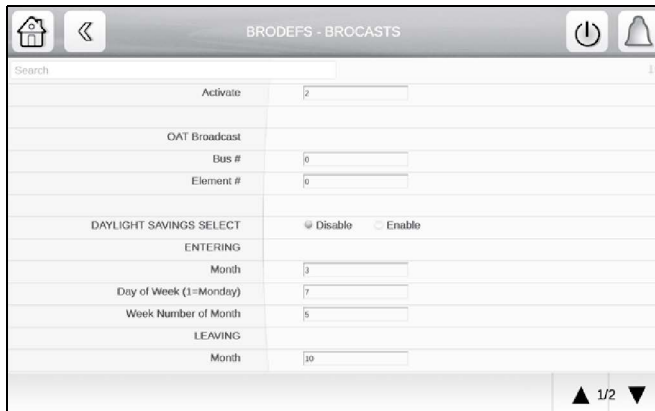

Fig. D — Broadcast Menu, Page 1 and 2

APPENDIX A — PIC 6 SCREEN AND TABLE STRUCTURE (cont)

BMS Protocol

CCN TABLE NAME: CONNECT

PIC 6 PATH: Main Menu → Configuration Menu → BMS Protocol

LINE	PIC 6 DESCRIPTION	CCN NAME	RANGE	DEFAULT VALUE*	UNIT	READ/WRITE
1	Port J8 Option 0=None, 1=BACnet MS/TP, 2=Modbus RTU	j8_opt	0 to 2	0		RW
Modbus Configuration						
2	Modbus TCP Enable	mip_opt	DSABLE/ENABLE	DSABLE		RW
3	Modbus TCP Port Number	port_nbr	0-1024	502		RW
4	Modbus Server UID	metric	NO/YES	NO		RW
5	Modbus Metric Unit	port_nbr	0 to 1024	502		RW
6	Modbus RTU Parity Option 0=No, 1=Odd, 2=Even, 3=Low, 4=High	parity	0 to 4	0		RW
7	Modbus RTU Stop Bit 1= 1 Bit, 2= 2 Bits	stop_bit	0 to 2	2		RW
8	Modbus RTU Baudrate 0=9600, 1=19200, 2=38400	baudrate	0 to 2	0		RW
9	Modbus Little Endian	swap_b	NO/YES	NO		RW
10	Modbus Real Type	real_typ	NO/YES	NO		RW
BACnet Configuration						
11	BACnet/IP Enable	bacena	DSABLE/ENABLE	ENABLE		RW
12	BACnet Metric Unit	bacunit	NO/YES	YES		RW
13	BACnet Network	network	1 to 9999	1600		RW
14	BACnet Identifier	ident	0 to 9999999	1600001		RW
15	BACnet Schedule Enable	bacschen	DSABLE/ENABLE	DSABLE		RW
16	MS/TP Mac address	mstpaddr	1 to 127	1		RW
17	MS/TP Baud Rate 0=9600, 1=19200, 2=38400, 3=57600, 4=76800, 5=115200	mstpbaud	0 to 5	2		RW
18	MS/TP Max Master	maxmastr	0 to 127	3		RW
19	MS/TP Max Info Frames		1 to 255	5		RW

LEGEND

RW — Read/Write

*Default value is shown only if configurable in this table.

NOTES:

1. The BACnet network and the device object identifier can be modified. The default identifier has been chosen to easily recognize the chiller on a BACnet network. The first two digits are the BACnet CARRIER vendor number (16). These parameters must be unique

on the BACnet network. They must be modified if more than one Carrier chiller is connected to the BACnet network.

2. Changing one of these BACnet parameters will cause a reboot of the board after 1 minute.
3. Changing IP address from the PIC 6 SETUP menu will require a manual reboot or power cycle of the PIC 6 controller in order to rebuild the BACnet stack.
4. For more information, see "CONFIGURING BMS PROTOCOL" on page 99.

APPENDIX A — PIC 6 SCREEN AND TABLE STRUCTURE (cont)

VFD Line Param Calib

CCN TABLE NAME: VFD_EFF

PIC 6 PATH: Main Menu → Configuration Menu → VFD_EFF

LINE	PIC 6 DESCRIPTION	CCN NAME	RANGE	DEFAULT VALUE	READ/WRITE
1	VFD Speed 100%, Load 100%	S100L100	85-100	96.6	RW
2	VFD Speed 100%, Load 70%	S100L70	85-100	95.4	RW
3	VFD Speed 100%, Load 50%	S100L50	85-100	94.6	RW
4	VFD Speed 100%, Load 30%	S100L30	85-100	93.6	RW
5	VFD Speed 100%, Load 10%	S100L10	85-100	92.2	RW
6	VFD Speed 92%, Load 100%	S92L100	85-100	95.3	RW
7	VFD Speed 92%, Load 70%	S92L70	85-100	94.6	RW
8	VFD Speed 92%, Load 50%	S92L50	85-100	94.1	RW
9	VFD Speed 92%, Load 30%	S92L30	85-100	92.8	RW
10	VFD Speed 92%, Load 10%	S92L10	85-100	91.4	RW
11	VFD Speed 83%, Load 100%	S83L100	85-100	95.1	RW
12	VFD Speed 83%, Load 70%	S83L70	85-100	94.5	RW
13	VFD Speed 83%, Load 50%	S83L50	85-100	93.3	RW
14	VFD Speed 83%, Load 30%	S83L30	85-100	92.0	RW
15	VFD Speed 83%, Load 10%	S83L10	85-100	89.9	RW
16	VFD Speed 70%, Load 100%	S70L100	85-100	94.8	RW
17	VFD Speed 70%, Load 70%	S70L70	85-100	94.0	RW
18	VFD Speed 70%, Load 50%	S70L50	85-100	92.7	RW
19	VFD Speed 70%, Load 30%	S70L30	85-100	91.0	RW
20	VFD Speed 70%, Load 10%	S70L10	85-100	88.6	RW
21	Calc Voltage Factor Stop	volfacts	0.5-1.5	1.00	RW
22	Calc Voltage Factor Run	volfactr	0.5-1.5	1.00	RW

LEGEND

RW — Read/Write

Low Load

CCN TABLE NAME: LQBP - Low Load

PIC 6 PATH: Main Menu → Configuration Menu → Low Load

LINE	PIC 6 DESCRIPTION	CCN NAME	RANGE	DEFAULT VALUE	UNIT	READ/WRITE
1	ECO LBP VLV Option	lqby_opt	DSABLE/ENABLE	DSABLE		RW
2	ECO LBP VLV Limit	lqbp_lmt	0-100	100	%	RW
3	DSH Deadband for LBP	dshdb	0-20	2	^F	RW
4	ECO LBP VLV Evap Approach	evapp_app	1-20	20	^F	RW
5	Dynamic Demand Limit	dyn_dem	DSABLE/ENABLE	ENABLE		RW
6	Ignore DDL Time	ign_ddl	0-60	30	min	RW
7	LCW at Selection Point		32-86	86	°F	RW
8	LCWM at Selection Point		59-113	59	°F	RW
9	100% Lift Demand Limit		10-100	10	%	RW
10	Middle Lift		40-80	40	%	RW
11	Middle Lift Demand Limit		0-100	100	%	RW
12	20% Lift Demand Limit		0-100	100	%	RW

LEGEND

RW — Read/Write

APPENDIX A — PIC 6 SCREEN AND TABLE STRUCTURE (cont)

Quick Test Menu

Navigation: **MAIN MENU** → **QUICK TEST**

Quick Test

CCN TABLE NAME: QCK_TEST

PIC 6 PATH: Main Menu → Quick Test

LINE	PIC 6 DESCRIPTION	CCN NAME	RANGE	DEFAULT VALUE*	UNIT	READ/WRITE
1	Quick Test Enable	QCK_TEST	DSABLE/ENABLE	DSABLE		RW
2	Oil Heater	Q_OILH	OFF/ON	Off		RW
3	Oil/Ref Pump	Q_OILP	OFF/ON	Off		RW
4	Oil/Ref Pres Test Passed	OP_PASS				RO
5	Oil/Ref Pump Delta Press	OIL_PDQ			PSI	RO
6	Oil Cooler EXV	Q_EXV		0	%	RW
7	HPR VLV Position	Q_HDP		0	%	RW
8	Chiller Status (Analog)	Q_CHST	4 to 20	4	ma	RW
9	Chiller Status (Discrete)	Q_RUN_ST	OFF/ON	Off		RW
10	Guide Vane 1 Tested Pos	Q_GV1POS	0 to 100	0	%	RW
11	Guide Vane 1 Open	Q_GV1OP	OFF/ON	Off		RW
12	Guide Vane 1 Close	Q_GV1CL	OFF/ON	Off		RW
13	Guide Vane 1 Actual Pos	Q_GV1ACT			%	RO
14	GV1/SRD Joint Test	Q_GVSRD	DSABLE/ENABLE	DSABLE		RW
15	Quick Test Diffuser Pos	Q_SRD	0 to 100	0	%	RW
16	Diffuser Pos	Q_DIFTGT			%	RO
17	EC/HG VLV Open	Q_HGBPOP	OFF/ON	Off		RW
18	EC/HG VLV Close	Q_HGBPCL	OFF/ON	Off		RW
19	EC/HG VLV Position	Q_HGBP_T		0	%	RW
20	ECO DMP VLV Pos	Q_DMP_T		0	%	RW
21	ECO DMP VLV Open	Q_DMPOP	OFF/ON	Off		RW
22	ECO DMP VLV Close	Q_DMPCCL	OFF/ON	Off		RW
23	Alarm Output	Q_ALM	OFF/ON	Off		RW
24	Alert Output	Q_ALE	OFF/ON	Off		RW
25	Condenser Water Pump	Q_CDWP	OFF/ON	Off		RW
26	Condenser Water Flow	CDW_FLOW	OFF/ON			RO
27	Chilled Water Pump	Q_CHWP	OFF/ON	Off		RW
28	Chilled Water Flow	CHW_FLOW	OFF/ON			RO
29	Condenser Water Delta T	CDW_DT			^F	RO
30	Chilled Water Delta T	CHW_DT			^F	RO
31	Liquid Level EXV	Q_LLCEXV		0	%	RW
32	ECO Vapor SV	Q_VSSV	OFF/ON	Off		RW
33	ECO LBP VLV mA	Q_LQBP	4-20		mA	RW
34	Free Cooling Mode	Q_FCMODE	OFF/ON	Off		RW
35	Low Speed Tower Fan	Q_LOWFAN	OFF/ON	Off		RW
36	High Speed Tower Fan	Q_HIFAN	OFF/ON	Off		RW
37	Shunt Trip Relay	Q_TRIPR	OFF/ON	Off		RW
38	Danfoss VFD Interlock	QVFDLOCK	OFF/ON	Off		RW

LEGEND

RO — Read Only
RW — Read/Write

*Default value is shown only if configurable in this table.

APPENDIX A — PIC 6 SCREEN AND TABLE STRUCTURE (cont)

Maintenance Menu

Navigation: **MAIN MENU** → **MAINTENANCE MENU**

ICON	DISPLAYED TEXT*	ACCESS	ASSOCIATED TABLE	PAGE NO.
	Capacity Control	Service	CAPACTRL	82
	Override Control	Service	OVERRIDE	82
	Surge Correction	Service	MAISURGE	83
	Swift Restart	Service	MAISWRST	83
	Master Slave	Service	MAIN_MS	84
	Power Line Parameters	Service	POWER_I	84
	Power Load Parameters	Service	POWER_O	86
	ISM Status	Service	MAIISMCM	85
	ISM or VFD History	Service	MAIISMHM	85
	VFD Status	Service	VFD_STAT	87
	Danfoss VFD Alarm	Service	DANFOSS	
	Maintenance SRD	Service	MAIN_SRD	88
	Maintenance Others	Service	MAIOTHER	89
	Maintenance IOB	Service	MAIOB	90
	Board Software PN	Service	MAI_BDSN	90
	Pressure Sensor Calib	Service	PRES_CAL	91
	Temp Sensor Calib	Service	TEMP_CAL	94
	ISM Calibration	Service	ISM_CAL	95
	System Status	Service	SYS_STAT	95
	System Information	Service	N/A	N/A

*Displayed text depends on the selected language (default is English).

APPENDIX A — PIC 6 SCREEN AND TABLE STRUCTURE (cont)

Capacity Control

CCN TABLE NAME: CAPACTRL

PIC 6 PATH: Main Menu → Maintenance Menu → Capacity Control

LINE	PIC 6 DESCRIPTION	CCN NAME	RANGE	DEFAULT VALUE*	UNIT	READ/WRITE
1	Total Error + Resets	tot_err			^F	RO
2	Control Point Error	ctrl_err			^F	RO
3	Controlled Water Temp	ctrl_wt			°F	RO
4	Control Point	ctrl_pnt			°F	RO
5	Actual Setpoint	setpoint			°F	RO
6	Entering Water Change DT	ewt_dt			^F	RO
7	Enter Water Temp Reset	ewt_res			^F	RO
8	Leaving Water Temp Reset	lwt_res			^F	RO
9	Discharge Gas Temp Reset	dgt_res			^F	RO
10	Capacity Delta	capa_dlt			%	RO
11	Target GV1 Pos	gv1_tgt			%	RO
12	GV1 Pos Change Delta	gv1delta			%	RO
13	Target GV2 Pos	gv2_tgt			%	RO
14	GV1 Change Flag Stop=0, Change=1, Cont=2	gv1_chg				RO
15	VFD Speed Change Flag Stop=0, Change=1, Cont=2	vfd_chg				RO
16	Target VFD Speed Per	vfd_tgt			%	RO
17	VFD Speed Change Delta	vfd_dlt			%	RO
18	Damper Target Percent	dmp_tp			%	RO
19	Damper Change Delta %	dmp_dlt			%	RO
20	ECV Target Percent	hgbbp_tp			%	RO
21	Capacity Inhibit Flag	cap_inh				RO
22	Capacity Decrease Flag	cap_dec				RO
23	Condenser Water Delta T	cdw_dt			^F	RO
24	Chilled Water Delta T	chw_dt			^F	RO
25	Pulldown Set Point	pull_set			°F	RO
26	Demand Limit Inh Clamp	deinhclm			%	RO
27	Ramping Demand Limit Val	ramp_dem			%	RO
28	Compressor is Running	comp_run				RO
29	Comp1 Run State Val	cm_stat1				RO

LEGEND

*Default value is shown only if configurable in this table.

RO — Read Only

Override Control

CCN TABLE NAME: OVERRIDE

PIC 6 PATH: Main Menu → Maintenance Menu → Override Control

LINE	PIC 6 DESCRIPTION	CCN NAME	RANGE	DEFAULT VALUE*	UNIT	READ/WRITE
1	Capacity Inhibit	cap_inho	NO/YES			RO
2	Capacity Decrease	cap_deco	NO/YES			RO
3	High Condenser Pressure	cpov_fl	NO/YES			RO
4	Low Discharge Superheat	dshov_fl	NO/YES			RO
5	Low Suction Sat Temp	sstov_fl	NO/YES			RO
6	High Motor Temp	mtov_fl	NO/YES			RO
7	High Bearing Temp	tbov_fl	NO/YES			RO
8	Low Source Temp	lstov_fl	NO/YES			RO
9	High Discharge Temp	dgtov_fl	NO/YES			RO
10	High Motor Current	ampov_fl	NO/YES			RO
11	Required DSH	dsh_req			°F	RO
12	Evap Sat Override Temp	ert_over			°F	RO
13	IGV Step DSH Increase	dshinstp			%	RO
14	IGV Step DSH Decrease	dshdestp			%	RO
15	Cond Press Trip Value	cp_trip			psig	RO
16	Cond P Override Value	cp_ov			psig	RO
17	High Inverter Temp	inov_fl	NO/YES			RO

LEGEND

RO — Read Only

*Default value is shown only if configurable in this table.

APPENDIX A — PIC 6 SCREEN AND TABLE STRUCTURE (cont)

Surge Correction

CCN TABLE NAME: MAISURGE

PIC 6 PATH: Main Menu → Maintenance Menu → Surge Correction

LINE	PIC 6 DESCRIPTION	CCN NAME	RANGE	DEFAULT VALUE*	UNIT	READ/WRITE
1	Surge Region 0 = No, 1 = Low, 2 = High, 3 = Deadband, 4 = Noise	act_reg	0 to 4			RO
2	Active Delta Tsat	dts_act			°F	RO
3	Calc Ref Delta Tsat	dts_cal			°F	RO
4	High Eff Delta Tsat	dts_he			°F	RO
5	Amps Change Surge Prot	amps_dta			%	RO
6	Max Amps Change Value	amch_max			%	RO
7	Surge Counts	sc				RO
8	Surge Protection Counts	spc				RO
9	Surge Prevention Active	surg_act	NO/YES			RO
10	Surge Protection Active	surg_pro	NO/YES			RO
11	EC/HG VLV Change Flag 0 = Close, 1 = Hold, 2 = Open	hgbp_chg	0 to 2			RO
12	Cal Surge Delta Tmax	dts_maxc	0 to 150.0		°F	RO
13	Cal Surge Delta Tmin	dts_minc	0 to 150.0		°F	RO
14	Cal Surge Delta Tmed	dts_medc	0 to 150.0		°F	RO
15	Opti-Sound IGV1 Position	gvi_smed			%	RO
16	Envelop Line/HG Opt	enlp_opt	NO/YES			RO

*Default value is shown only if configurable in this table.

LEGEND

RO — Read Only
RW — Read/Write

Swift Restart

CCN TABLE NAME: MAISWRST

PIC 6 PATH: Main Menu → Maintenance Menu → Swift Restart

LINE	PIC 6 DESCRIPTION	CCN NAME	RANGE	DEFAULT VALUE*	UNIT	READ/WRITE
1	SRD Position @Shutdown	srd_shut	0 to 100		%	RO
2	VFD Speed @Shutdown	vfd_shut	0 to 100		%	RO
3	GV1 Position @Shutdown	gv1_shut	0 to 100		%	RO
4	Evap Sat Temp @Shutdown	est_shut	-40 to 280		°F	RO
5	Power Recovery Duration	pd_dur	0 to 65535		min	RO
6	Power Down Active	power_dn	NO/YES			RO
7	Auto Restart Active	auto_rst	NO/YES			RO
8	Swift Restart Active	sw_rst	NO/YES			RO

LEGEND

RO — Read Only

*Default value is shown only if configurable in this table.

APPENDIX A — PIC 6 SCREEN AND TABLE STRUCTURE (cont)

Master Slave

CCN TABLE NAME: MAIN_MS

PIC 6 PATH: Main Menu → Maintenance Menu → Master Slave

LINE	PIC 6 DESCRIPTION	CCN NAME	RANGE	DEFAULT VALUE*	UNIT	READ/WRITE
1	Unit is Lead or Lag 0 = Disable, 1 = Lead, 2 = Lag	lead_lag	0 to 2			RO
2	Master Control Type 0 = Local, 1 = Network, 2 = Remote, 3 = Local Sched	ms_ctrl	0 to 3			RO
3	Slave Control Type 0 = Local 1 = Network 2 = Remote 3 = Local Sched	sl_ctrl	0 to 3			RO
4	Lead Lag Communication	ll_comm	TRUE/FALSE			RO
5	Master Slave Fault 0 = No Fault, 1 = Master 2 = Slave, 3 = Both	ll_fault	0 to 3			RO
6	Slave Run Status	lagstat	0 to 14			RO
7	Slave Start/Stop	lag_s_s	START/STOP			RO
8	Capacity Decrease	CAP_DECL	NO/YES			RO
9	Capacity Inhibit	CAP_INHL	NO/YES			RO
10	Master Chiller Running	MST_RUN	NO/YES			RO
11	Local Surge Status	LCL_SRG	0 to 3			RO
12	Remote Surge Status	RMT_SRG	0 to 3			RO
13	EWT Control Option	EWT_OPT	DSABLE/ENABLE			RO
14	Demand Limit Source 0 = Amps, 1 = KW	DEM_SLCT	0 to 1			RO
15	Lag Start Timer	lagstart	0 to 60		min	RO
16	Lag Stop Timer	lagstop	0 to 60		min	RO
17	Prestart Fault Timer	preflt	0 to 30		min	RO
18	Pulldown Timer	pulltime	0 to 30		min	RO
19	Pulldown: Delta T / Min	pull_dt	0 to 100		°F	RO
20	Lead/Lag Hours Delta	ll_hr_d	-99999 to 99999		hours	RO
21	Overrid Control Point	ctrpntov	10 to 160.0		°F	RO
22	Overrid Act Demand Limit	demlimov	10 to 100.0		%	RO

Power Line Parameters

CCN TABLE NAME: POWER_I

PIC 6 PATH: Main Menu → Maintenance Menu → Power Line Parameters

LINE	PIC 6 DESCRIPTION	CCN NAME	RANGE	DEFAULT VALUE*	UNIT	READ/WRITE
1	Line Current Phase 1	LN_AMPS1			amp	RO
2	Line Current Phase 2	LN_AMPS2			amp	RO
3	Line Current Phase 3	LN_AMPS3			amp	RO
4	Actual Line Current	AMPS_A			amp	RO
5	Percent Line Current	AMPS_P			%	RO
6	Ground Fault Phase 1	GRFT_1			amp	RO
7	Ground Fault Phase 2	GRFT_2			amp	RO
8	Ground Fault Phase 3	GRFT_3			amp	RO
9	Line Voltage Phase 1	LN_VOLT1			V	RO
10	Line Voltage Phase 2	LN_VOLT2			V	RO
11	Line Voltage Phase 3	LN_VOLT3			V	RO
12	Actual Line Voltage	VOLT_A			V	RO
13	Percent Line Voltage	VOLT_P			%	RO
14	Line Kilowatts	KW			kW	RO
15	Line Frequency	LN_FREQ			Hz	RO
16	Power Factor	POW_FACT				RO

LEGEND

RO — Read Only

*Default value is shown only if configurable in this table.

APPENDIX A — PIC 6 SCREEN AND TABLE STRUCTURE (cont)

ISM Status

CCN TABLE NAME: MAIISMC

PIC 6 PATH: Main Menu → Maintenance Menu → ISM Status

LINE	PIC 6 DESCRIPTION	CCN NAME	RANGE	DEFAULT VALUE*	UNIT	READ/WRITE
1	Single Cycle Dropout	cycle_1	NO/YES			RO
2	Phase Loss	ph_loss	NO/YES			RO
3	Over Voltage	ov_volt	NO/YES			RO
4	Under Voltage	un_volt	NO/YES			RO
5	Current Imbalance	amp_unb	NO/YES			RO
6	Voltage Imbalance	volt_unb	NO/YES			RO
7	Overload Trip	overload	NO/YES			RO
8	Locked Rotor Trip	lratrip	NO/YES			RO
9	Starter LRA Trip	slratrip	NO/YES			RO
10	Ground Fault	grnd_fit	NO/YES			RO
11	Phase Reversal	ph_rev	NO/YES			RO
12	Frequency Out of Range	freqflt	NO/YES			RO
13	ISM Power On Reset	ism_por	NO/YES			RO
14	Phase 1 Fault	phase_1	NO/YES			RO
15	Phase 2 Fault	phase_2	NO/YES			RO
16	Phase 3 Fault	phase_3	NO/YES			RO
17	1CR Start Complete	start_ok	NO/YES			RO
18	1M Start/Run Fault	1m_fit	NO/YES			RO
19	2M Start/Run Fault	2m_fit	NO/YES			RO
20	Pressure Trip Contact	prs_trip	NO/YES			RO
21	Starter Fault	strt_fit	NO/YES			RO
22	Motor Amps Not Sensed	no_amps	NO/YES			RO
23	Starter Accel Fault	accelflt	NO/YES			RO
24	High Motor Amps	highamps	NO/YES			RO
25	1CR Stop Complete	stop_ok	NO/YES			RO
26	1M/2M Stop Fault	1m2mstop	NO/YES			RO
27	Motor Amps When Stopped	ampstop	NO/YES			RO
28	Hardware Failure	hardware	NO/YES			RO
29	Calibration Factor Error	calfc_er	NO/YES			RO
30	Invalid Configuration	conf_err	NO/YES			RO
31	Unused	un_used	NO/YES			RO

ISM or VFD History

CCN TABLE NAME: MAIISMH

PIC 6 PATH: Main Menu → Maintenance Menu → ISM History

LINE	PIC 6 DESCRIPTION	CCN NAME	RANGE	DEFAULT VALUE*	UNIT	READ/WRITE
1	Line Current Phase 1	AMPS_H1			amp	RO
2	Line Current Phase 2	AMPS_H2			amp	RO
3	Line Current Phase 3	AMPS_H3			amp	RO
4	Line Frequency	FREQ_H			Hz	RO
5	Ground Fault Phase 3	GRFT_H1			amp	RO
6	Ground Fault Phase 2	GRFT_H2			amp	RO
7	Ground Fault Phase 1	GRFT_H3			amp	RO
8	Phase 1 Faulted	phase_h1	NO/YES			RO
9	Phase 2 Faulted	phase_h2	NO/YES			RO
10	Phase 3 Faulted	phase_h3	NO/YES			RO
11	I2T Sum Heat Phase 1	sum1ht_h			%	RO
12	I2T Sum Heat Phase 2	sum2ht_h			%	RO
13	I2T Sum Heat Phase 3	sum3ht_h			%	RO
14	Line Voltage Phase 1	VOLT_H1			V	RO
15	Line Voltage Phase 2	VOLT_H2			V	RO
16	Line Voltage Phase 3	VOLT_H3			V	RO
17	Load Current Phase 1	ld_am1			amp	RO
18	Load Current Phase 2	ld_am2			amp	RO
19	Load Current Phase 3	ld_am3			amp	RO
20	DC Bus Voltage	bus_volt			V	RO

LEGEND

RO — Read Only

*Default value is shown only if configurable in this table.

APPENDIX A — PIC 6 SCREEN AND TABLE STRUCTURE (cont)

Power Load Parameters

CCN TABLE NAME: POWER_O

PIC 6 PATH: Main Menu → Maintenance Menu → Power Load Parameters

LINE	PIC 6 DESCRIPTION	CCN NAME	RANGE	DEFAULT VALUE*	UNIT	READ/WRITE
1	VLF Load Current	VFD_LOAD			amp	
2	Percent VFD Load Current	amps_p_o			%	
3	Ground Fault Current	gf_amps			amp	
4	Motor Current Imbalance	mt_imb_i			%	
5	Motor Actual Frequency	MOT_FREQ			Hz	
6	Motor Target Frequency	tgt_freq			Hz	
7	DC Bus Voltage	bus_volt			V	
8	DC Bus Voltage Reference	bus_ref			V	
9	Load Current Ph 1(U)	ld_amps1			amp	
10	Load Current Ph 2(V)	ld_amps2			amp	
11	Load Current Ph 3(W)	ld_amps3			amp	
12	Actual VFD Speed Per	vfd_act			%	
13	Motor Power Factor	motor_pf				
14	Motor Kilowatts	motor_kw			kW	
15	Motor Overload	motor_ov			%	
16	Motor Kilowatt-Hours	motorkwh				
17	Rectifier Overload	rect_ov			%	
18	Inverter Overload	inv_ov			%	
19	VFD Enclosure Temp	enc_temp			°F	
20	VFD Cold Plate Temp	cp_temp			°F	
21	Inverter Temperature	inv_temp			°F	
22	Rectifier Temperature	rec_temp			°F	
23	Shunt Trip Relay Status	tripr	0 to 1			
24	Precharge Relay Status	prechar	0 to 1			
25	VFD Run Relay Status	vfd_run	0 to 1			
26	Precharge Feedback	prech_fd	0 to 1			
27	VFD Load Factor	VFD_FACT				
28	VFD Load Current	VFD_LOAD			amp	
29	LR Temp Switch	lrtem_sw	0 to 1			
30	VFD Alarm Code	alm_code				
31	VFD Status Word	stat_wd				
32	VFD Command Word	cmd_wd				
33	VFD Start Inhibit Status	str_inh				
34	VFD Appl Digital Output	appl_do				
35	Safety Stop Status	safestop	0 to 1			
36	SPD Feedback	spd_fd	0 to 1			
37	High VFD Current	VFDC_HI	NO/YES			

*Default value is shown only if configurable in this table.

APPENDIX A — PIC 6 SCREEN AND TABLE STRUCTURE (cont)

VFD Status

CCN TABLE NAME: VFD_STAT

PIC 6 PATH: Main Menu → Maintenance Menu → UM VFD Status

LINE	PIC 6 DESCRIPTION	CCN NAME	RANGE	DEFAULT VALUE*	UNIT	READ/WRITE
1	Single Cycle Dropout	cycle_1	NO/YES	NO		RO
2	Line Current Imbalance	lineim_i	NO/YES	NO		RO
3	High Line Voltage	hi_volt	NO/YES	NO		RO
4	Low Line Voltage	low_volt	NO/YES	NO		RO
5	Low DC Bus Voltage	lo_dcbus	NO/YES	NO		RO
6	High DC Bus Voltage	hi_dcbus	NO/YES	NO		RO
7	VFD Power On Reset	vfd_por	NO/YES	NO		RO
8	Ground Fault	grnd_flt	NO/YES	NO		RO
9	Line Phase Reversal	ph_rev	NO/YES	NO		RO
10	Motor Overload Trip	motor_ov	NO/YES	NO		RO
11	Start Complete	start_ok	NO/YES	NO		RO
12	Rectifier Power Fault	rect_pu	NO/YES	NO		RO
13	Invert Power Fault	inv_pu	NO/YES	NO		RO
14	Rectifier Overcurrent	rect_oi	NO/YES	NO		RO
15	Inverter Overcurrent	inv_oi	NO/YES	NO		RO
16	Condenser High Pressure	prs_trip	NO/YES	NO		RO
17	Motor Amps Not Sensed	no_amps	NO/YES	NO		RO
18	Motor Acceleration Fault	acccflt	NO/YES	NO		RO
19	Stop Complete	stop_ok	NO/YES	NO		RO
20	Stop Fault	ampstop	NO/YES	NO		RO
21	Rectifier Overtemp	rect_ot	NO/YES	NO		RO
22	Inverter Overtemp	inv_ot	NO/YES	NO		RO
23	Motor Current Imbalance	motim_i	NO/YES	NO		RO
24	Line Voltage Imbalance	lineim_v	NO/YES	NO		RO
25	Frequency Fault	freqflt	NO/YES	NO		RO
26	VFD Comm Fault	vfd_comm	NO/YES	NO		RO
27	VFD Fault	vfdfault	NO/YES	NO		RO
28	Read Config Complete	readone	NO/YES	NO		RO
29	VFD Start Inhibit	strt_inh	NO/YES	NO		RO
30	VFD Checksum Error	checksum	NO/YES	NO		RO
31	Inductor Overtemp Switch	inot_sw	NO/YES	NO		RO
32	Incompatibility Fault	incomp	NO/YES	NO		RO

LEGEND

RO — Read Only

*Default value is shown only if configurable in this table.

APPENDIX A — PIC 6 SCREEN AND TABLE STRUCTURE (cont)
DANFOSS

CCN TABLE NAME: DANFOSS VFD

PIC 6 PATH: Main Menu → Maintenance Menu → Danfoss VFD Status

LINE	PIC 6 DESCRIPTION	CCN NAME	RANGE	DEFAULT VALUE*	UNIT	READ/WRITE
1	VFD Alarm Code	vfd_code				RO
2	Brake Check	BC_00				RO
3	Power Card over Temp	pcot_01				RO
4	Earth Fault	ef_02				RO
5	Ctrl Card over Temp	ccot_03				RO
6	Control Word Timeout	cwt_04				RO
7	Over Current	oc_05				RO
8	Torque Limit	tl_06				RO
9	Motor Therm over Temp	mtot_07				RO
10	Motor Etr over temp	meot_08				RO
11	Inverter Overload	io_09				RO
12	DC Link under Voltage	dluv_10				RO
13	DC Link over Voltage	dlov_11				RO
14	Short Circuit	sc_12				RO
15	Inrush Fault	if_13				RO
16	Mains Phase Loss	mpl_14				RO
17	AMA Not Ok	ano_15				RO
18	Live Zero Error	lze_16				RO
19	Internal Fault	if_17				RO
20	Brake Overload	bo_18				RO
21	Motor Phase U Missing	mpum_19				RO
22	Motor Phase V Missing	mpvm_20				RO
23	Motor Phase W Missing	mpwm_21				RO
24	FieldBus Fault	ff_22				RO
25	24V Supply Fault	vsf_23				RO
26	Mains Failure	mf_24				RO
27	1.8V Supply Fault	sf_25				RO
28	Brake Res Short Cir	brsc_26				RO
29	Brake IGBT Fault	bif_27				RO
30	Option Change	oc_28				RO
31	Drive Initialized	di_29				RO
32	Sate Stop	ss_30				RO
33	Service Trip	st_02				RO
34	End of Curve	eco_07				RO
35	Broken Belt	bb_08				RO
36	Fans Error	fe_18				RO
37	PCT1 Safe Stop	pss_30				RO
38	Dangerous Failure	df_31				RO

Maintenance SRD

CCN TABLE NAME: MAIN_SRD

PIC 6 PATH: Main Menu → Maintenance Menu → Maintenance SRD

LINE	PIC 6 DESCRIPTION	CCN NAME	RANGE	DEFAULT VALUE*	UNIT	READ/WRITE
1	Diffuser Target Pos	diff_tgt			%	RO
2	Diffuser Fault	diffault	NO/YES			RO
3	SRD Rotating Stall Alarm	diff_alm	NO/YES			RO
4	Calculated SRD Position	srd_a			%	RO
5	Calc High Lift SRD Pos	srd_1			%	RO
6	Calc Low Lift SRD Pos	srd_2			%	RO
7	Actual Lift	lift_a			°F	RO
8	VDO High Lift Load Line	lift_1			°F	RO
9	VDO Low Lift Load Line	lift_2			°F	RO
10	VDO Logic Start Delay	strt_tmr			min	RO
11	SRD Stall Closure Time	stalltmr			min	RO

LEGEND

RO — Read Only

*Default value is shown only if configurable in this table.

APPENDIX A — PIC 6 SCREEN AND TABLE STRUCTURE (cont)

Maintenance Others

CCN TABLE NAME: MAIOTHER

PIC 6 PATH: Main Menu → Maintenance Menu → Maintenance Others

LINE	PIC 6 DESCRIPTION	CCN NAME	RANGE	DEFAULT VALUE*	UNIT	READ/WRITE
1	5V Sensor Power Monitor	tran_v			V	RO
2	Evap Pres Trans Volts	evapp_v			V	RO
3	Cond Pres Trans Volts	condp_v			V	RO
4	ECO Pres Trans Volts	econp_v			V	RO
5	Diffuser Pres Tran Volts	diffp_v			V	RO
6	Oil Sump Pres Tran Volts	opsmp_v			V	RO
7	Oil Sup Pres Trans Volts	opdis_v			V	RO
8	Evap Enter Water Volts	evewp_v			V	RO
9	Evap Leave Water Volts	evlwp_v			V	RO
10	Cond Enter Water Volts	cdewp_v			V	RO
11	Cond Leave Water Volts	cdlwp_v			V	RO
12	Bearing In Trans Volt,	brgip_v			V	RO
13	Bearing Out Trans Volt,	brgop_v			V	RO
14	Pump Output Trans Volt,	pumpo_v			V	RO
15	Pump Input Trans Volt,	pumpi_v			V	RO
16	Last Cond Pump Run Time	last_cpt				RO
17	Prestart Check Status	pre_chck	NO/YES			RO
18	GV1 Pos at Startup OK	gvpos_ok	NO/YES			RO
19	Pump PD at Startup OK	oilpd_ok	NO/YES			RO
20	EC/HG Pos at Startup OK	hgbp_ok	NO/YES			RO
21	ECO DMP VLV Startup OK	dmp_ok	NO/YES			RO
22	Oil Pump Req Oil Heater	op_heat	NO/YES			RO
23	Oil Pump Req Prestart	op_prest	NO/YES			RO
24	Pump Req Startup	op_start	NO/YES			RO
25	Pump Req Shutdown	op_shut	NO/YES			RO
26	Pump Req Swift Rst	op_srst	NO/YES			RO
27	Evap Pump Req Startup	ep_start	NO/YES			RO
28	Evap Pump Req Diagnostic	ep_diag	NO/YES			RO
29	Evap Pump Req Frozen	ep_freze	NO/YES			RO
30	Evap Pump Req Shutdown	ep_shut	NO/YES			RO
31	Evap Pump Req Pumpdown	ep_pdown	NO/YES			RO
32	Cond Pump Req Prestart	cp_prest	NO/YES			RO
33	Cond Pump Req Startup	cp_start	NO/YES			RO
34	Cond Pump Req Override	cp_overr	NO/YES			RO
35	Cond Pump Req Shutdown	cp_shut	NO/YES			RO
36	Cond Pump Req Tower	cp_tower	NO/YES			RO
37	Cond Pump Req Diagnostic	co_diag	NO/YES			RO
38	Cond Pump Req Frozen	cp_freze	NO/YES			RO
39	Cond Pump Req Pumpdown	cp_pdown	NO/YES			RO
40	Capacity Inhibit Ramping	cap_inhr	NO/YES			RO
41	Capacity Inhibit Demand	cap_inhd	NO/YES			RO
42	Capacity Decrease Demand	cap_decd	NO/YES			RO
43	Guide Vane Inh Surge	gv1_inhs	NO/YES			RO
44	Capacity Decrease Surge	cap_decs	NO/YES			RO
45	Capacity Inh Low SST	capinhst	NO/YES			RO
46	Capacity Dec Low SST	capdecst	NO/YES			RO
47	Capacity Inh Cond Pres	capinhcp	NO/YES			RO
48	Capacity Dec Cond Pres	capdeccp	NO/YES			RO
49	Capacity Inh Motor Temp	capinhmt	NO/YES			RO
50	Capacity Dec Motor Temp	capdecmt	NO/YES			RO
51	Capacity Inh Hi Current	capinham	NO/YES			RO
52	Capacity Dec Hi Current	capdecam	NO/YES			RO
53	Capacity Dec Low Temp	capdecls	NO/YES			RO
54	Capacity Inh Inverter	capinhiv	NO/YES			RO
55	Capacity Dec Inverter	capdeciv	NO/YES			RO
56	GV2 Pos at Startup OK	gv2posok	NO/YES			RO

LEGEND

RO — Read Only

*Default value is shown only if configurable in this table.

APPENDIX A — PIC 6 SCREEN AND TABLE STRUCTURE (cont)

Maintenance IOB

CCN TABLE NAME: MAIIOB

PIC 6 PATH: Main Menu → Maintenance Menu → Maintenance IOB

LINE	PIC 6 DESCRIPTION	CCN NAME	RANGE	DEFAULT VALUE*	UNIT	READ/WRITE
1	IOB1 Power Supply Volt	vol_job1			V	RO
2	IOB1 Num Peak Prev Sec	nm_peak1				RO
3	IOB1 Low Voltage Flag	low_vol1	NO/YES			RO
4	IOB1 24VAC Fuse Status	fusstat1	CLOSE/OPEN			RO
5	IOB2 Power Supply Volt	vol_job2			V	RO
6	IOB2 Num Peak Prev Sec	nm_peak2				RO
7	IOB2 Low Voltage Flag	low_vol2	NO/YES			RO
8	IOB2 24VAC Fuse Status	fusstat2	CLOSE/OPEN			RO
9	IOB3 Power Supply Volt	vol_job3			V	RO
10	IOB3 Num Peak Prev Sec	nm_peak3				RO
11	IOB3 Low Voltage Flag	low_vol3	NO/YES			RO
12	IOB3 24VAC Fuse Status	fusstat3	CLOSE/OPEN			RO
13	IOB4 Power Supply Volt	vol_job4			V	RO
14	IOB4 Num Peak Prev Sec	nm_peak4				RO
15	IOB4 Low Voltage Flag	low_vol4	NO/YES			RO
16	IOB4 24VAC Fuse Status	fusstat4	CLOSE/OPEN			RO
17	IOB5 Power Supply Volt	vol_job5			V	RO
18	IOB5 Num Peak Prev Sec	nm_peak5				RO
19	IOB5 Low Voltage Flag	low_vol5	NO/YES			RO
20	IOB5 24VAC Fuse Status	fusstat5	CLOSE/OPEN			RO
21	IOB6 Power Supply Volt	vol_job6			V	RO
22	IOB6 Num Peak Prev Sec	nm_peak6				RO
23	IOB6 Low Voltage Flag	low_vol6	NO/YES			RO
24	IOB6 24VAC Fuse Status	fusstat6	CLOSE/OPEN			RO

Board Software PN

CCN TABLE NAME: MAI_BDSN

PIC 6 PATH: Main Menu → Maintenance Menu → Board Software PN

LINE	PIC 6 DESCRIPTION	CCN NAME	RANGE	DEFAULT VALUE*	UNIT	READ/WRITE
1	IOB #1 Soft Part Number	sn_job1				RO
2	IOB #2 Soft Part Number	sn_job2				RO
3	IOB #3 Soft Part Number	sn_job3				RO
4	IOB #4 Soft Part Number	sn_job4				RO
5	IOB #5 Soft Part Number	sn_job5				RO
6	IOB #6 Soft Part Number	sn_job6				RO
7	SIOB Soft Part Number	sn_siob				RO
8	ISM Software Part Number	sn_ism				RO
9	Gateway Soft Part Number	sn_gw				RO
10	DCIB Soft Part Number	sn_dcib				RO
11	MBB SVN Revision	svn_rev				RO

LEGEND











RO — Read Only

*Default value is shown only if configurable in this table.

APPENDIX A — PIC 6 SCREEN AND TABLE STRUCTURE (cont)

Pressure Sensor Calib (PRES_CAL) Menu Description

Navigation: **MAIN MENU** → **MAINTENANCE MENU** → **PRESSURE SENSOR CALIB**

ICON	DISPLAYED TEXT	ACCESS	ASSOCIATED TABLE	PAGE NO.
	Evap Pressure Sensor	Service	PRSCAL01	92
	Cond Pressure Sensor	Service	PRSCAL02	92
	Eco Pressure Sensor	Service	PRSCAL03	92
	Diff Pressure Sensor	Service	PRSCAL04	92
	Oil Sump Pressure	Service	PRSCAL05	93
	Oil Supply Pressure	Service	PRSCAL06	93
	Evap Entering Water P	Service	PRSCAL07	93
	Evap Leaving Water P	Service	PRSCAL08	93
	Cond Entering Water P	Service	PRSCAL09	94
	Cond Leaving Water P	Service	PRSCAL10	94

APPENDIX A — PIC 6 SCREEN AND TABLE STRUCTURE (cont)

Evap Pressure Sensor

CCN TABLE NAME: PRSCAL01

PIC 6 PATH: Main Menu → Maintenance Menu → Pressure Sensor Calib → Evap Pressure Sensor

LINE	PIC 6 DESCRIPTION	CCN NAME	RANGE	DEFAULT VALUE*	UNIT	READ/WRITE
1	Evap Pressure Sensor					
2	Calibration Enable	cal_en	DSABLE/ENABLE	DSABLE		RW
3	Calibration Completed	cal_st	NO/YES	NO		RO
4	Calibrated Slope	cal_s				RO
5	Calibrated Intercept	cal_i				RO
6	Current Pressure	cur_pres			psig	RO
7	Calib Press1 (0 PSI)	cal_p1	9 digit numeric string	0	psig	RW
8	Calib Press2 (100-250 PSI)	cal_p2	9 digit numeric string	0	psig	RW

Cond Pressure Sensor

CCN TABLE NAME: PRSCAL02

PIC 6 PATH: Main Menu → Maintenance Menu → Pressure Sensor Calib → Cond Pressure Sensor

LINE	PIC 6 DESCRIPTION	CCN NAME	RANGE	DEFAULT VALUE*	UNIT	READ/WRITE
1	Cond Pressure Sensor					
2	Calibration Enable	cal_en	DSABLE/ENABLE	DSABLE		RW
3	Calibration Completed	cal_st	NO/YES	NO		RO
4	Calibrated Slope	cal_s				RO
5	Calibrated Intercept	cal_i				RO
6	Current Pressure	cur_pres			psig	RO
7	Calib Press1 (0 PSI)	cal_p1	9 digit numeric string	0	psig	RW
8	Calib Press2 (100-250 PSI)	cal_p2	9 digit numeric string	0	psig	RW

Eco Pressure Sensor

CCN TABLE NAME: PRSCAL03

PIC 6 PATH: Main Menu → Maintenance Menu → Pressure Sensor Calib → Eco Pressure Sensor

LINE	PIC 6 DESCRIPTION	CCN NAME	RANGE	DEFAULT VALUE*	UNIT	READ/WRITE
1	Eco Pressure Sensor					
2	Calibration Enable	cal_en	DSABLE/ENABLE	DSABLE		RW
3	Calibration Completed	cal_st	NO/YES	NO		RO
4	Calibrated Slope	cal_s				RO
5	Calibrated Intercept	cal_i				RO
6	Current Pressure	cur_pres			psig	RO
7	Calib Press1 (0 PSI)	cal_p1	9 digit numeric string	0	psig	RW
8	Calib Press2 (100-250 PSI)	cal_p2	9 digit numeric string	0	psig	RW

Diff Pressure Sensor

CCN TABLE NAME: PRSCAL04

PIC 6 PATH: Main Menu → Maintenance Menu → Pressure Sensor Calib → Diff Pressure Sensor

LINE	PIC 6 DESCRIPTION	CCN NAME	RANGE	DEFAULT VALUE*	UNIT	READ/WRITE
1	Diff Pressure Sensor					
2	Calibration Enable	cal_en	DSABLE/ENABLE	DSABLE		RW
3	Calibration Completed	cal_st	NO/YES	NO		RO
4	Calibrated Slope	cal_s				RO
5	Calibrated Intercept	cal_i				RO
6	Current Pressure	cur_pres			psig	RO
7	Calib Press1 (0 PSI)	cal_p1	9 digit numeric string	0	psig	RW
8	Calib Press2 (100-250 PSI)	cal_p2	9 digit numeric string	0	psig	RW

LEGEND

RO — Read Only
RW — Read/Write

*Default value is shown only if configurable in this table.

APPENDIX A — PIC 6 SCREEN AND TABLE STRUCTURE (cont)

Oil Sump Pressure

CCN TABLE NAME: PRSCAL05

PIC 6 PATH: Main Menu → Maintenance Menu → Pressure Sensor Calib → Oil Sump Pressure

LINE	PIC 6 DESCRIPTION	CCN NAME	RANGE	DEFAULT VALUE*	UNIT	READ/WRITE
1	Oil Sump Pressure					
2	Calibration Enable	cal_en	DSABLE/ENABLE	DSABLE		RW
3	Calibration Completed	cal_st	NO/YES	0		RO
4	Calibrated Slope	cal_s		0		RO
5	Calibrated Intercept	cal_i		0		RO
6	Current Pressure	cur_pres			psig	RO
7	Calib Press1 (0 PSI)	cal_p1	9 digit numeric string	0	psig	RW
8	Calib Press2 (100-250 PSI)	cal_p2	9 digit numeric string	0	psig	RW

Oil Supply Pressure

CCN TABLE NAME: PRSCAL06

PIC 6 PATH: Main Menu → Maintenance Menu → Pressure Sensor Calib → Oil Supply Pressure

LINE	PIC 6 DESCRIPTION	CCN NAME	RANGE	DEFAULT VALUE*	UNIT	READ/WRITE
1	Oil Supply Pressure					
2	Calibration Enable	cal_en	DSABLE/ENABLE	DSABLE		RW
3	Calibration Completed	cal_st	NO/YES	NO		RO
4	Calibrated Slope	cal_s				RO
5	Calibrated Intercept	cal_i				RO
6	Current Pressure	cur_pres			psig	RO
7	Calib Press1 (0 PSI)	cal_p1	9 digit numeric string	0	psig	RW
8	Calib Press2 (100-250 PSI)	cal_p2	9 digit numeric string	0	psig	RW

Evap Entering Water P

CCN TABLE NAME: PRSCAL07

PIC 6 PATH: Main Menu → Maintenance Menu → Pressure Sensor Calib → Evap Entering Water P

LINE	PIC 6 DESCRIPTION	CCN NAME	RANGE	DEFAULT VALUE*	UNIT	READ/WRITE
1	Evap Entering Water P					
2	Calibration Enable	cal_en	DSABLE/ENABLE	DSABLE		RW
3	Calibration Completed	cal_st	NO/YES	NO		RO
4	Calibrated Slope	cal_s				RO
5	Calibrated Intercept	cal_i				RO
6	Current Pressure	cur_pres			psig	RO
7	Calib Press1 (0 PSI)	cal_p1	9 digit numeric string	0	psig	RW
8	Calib Press2 (100-250 PSI)	cal_p2	9 digit numeric string	0	psig	RW

Evap Leaving Water P

CCN TABLE NAME: PRSCAL08

PIC 6 PATH: Main Menu → Maintenance Menu → Pressure Sensor Calib → Evap Leaving Water P

LINE	PIC 6 DESCRIPTION	CCN NAME	RANGE	DEFAULT VALUE*	UNIT	READ/WRITE
1	Evap Leaving Water P					
2	Calibration Enable	cal_en	DSABLE/ENABLE	DSABLE		RW
3	Calibration Completed	cal_st	NO/YES	NO		RO
4	Calibrated Slope	cal_s				RO
5	Calibrated Intercept	cal_i				RO
6	Current Pressure	cur_pres			psig	RO
7	Calib Press1 (0 PSI)	cal_p1	9 digit numeric string	0	psig	RW
8	Calib Press2 (100-250 PSI)	cal_p2	9 digit numeric string	0	psig	RW

LEGEND

RO — Read Only
RW — Read/Write

*Default value is shown only if configurable in this table.

APPENDIX A — PIC 6 SCREEN AND TABLE STRUCTURE (cont)

Cond Entering Water P

CCN TABLE NAME: PRSCAL09

PIC 6 PATH: Main Menu → Maintenance Menu → Pressure Sensor Calib → Cond Entering Water P

LINE	PIC 6 DESCRIPTION	CCN NAME	RANGE	DEFAULT VALUE*	UNIT	READ/WRITE
1	Cond Entering Water P					
2	Calibration Enable	cal_en	DSABLE/ENABLE	DSABLE		RW
3	Calibration Completed	cal_st	NO/YES	NO		RO
4	Calibrated Slope	cal_s				RO
5	Calibrated Intercept	cal_i				RO
6	Current Pressure	cur_pres			psig	RO
7	Calib Press1(0 PSI)	cal_p1	9 digit numeric string	0	psig	RW
8	Calib Press2 (100-250 PSI)	cal_p2	9 digit numeric string	0	psig	RW

Cond Leaving Water P

CCN TABLE NAME: PRSCAL10

PIC 6 PATH: Main Menu → Maintenance Menu → Pressure Sensor Calib → Cond Leaving Water P

LINE	PIC 6 DESCRIPTION	CCN NAME	RANGE	DEFAULT VALUE*	UNIT	READ/WRITE
1	Cond Leaving Water P					
2	Calibration Enable	cal_en	DSABLE/ENABLE	DSABLE		RW
3	Calibration Completed	cal_st	NO/YES	NO		RO
4	Calibrated Slope	cal_s				RO
5	Calibrated Intercept	cal_i				RO
6	Current Pressure	cur_pres			psig	RO
7	Calib Press1(0 PSI)	cal_p1	9 digit numeric string	0	psig	RW
8	Calib Press2 (100-250 PSI)	cal_p2	9 digit numeric string	0	psig	RW

LEGEND

*Default value is shown only if configurable in this table.

RO — Read Only
RW — Read/Write

Temp Sensor Calib

CCN TABLE NAME: TEMP_CAL

PIC 6 PATH: Main Menu → Maintenance Menu → Temp Sensor Calib

LINE	PIC 6 DESCRIPTION	CCN NAME	RANGE	DEFAULT VALUE*	UNIT	READ/WRITE
1	Entering Chilled Water	ECW			°F	RO
2	ECW Sensor Raw Temp	ECW_RAW			°F	RO
3	ECW Temperature Offset	ECW_OFF	-2.0 to 2.0	0	^F	RW
4	Leaving Chilled Water	LCW			°F	RO
5	LCW Sensor Raw Temp	LCW_RAW			°F	RO
6	LCW Temperature Offset	LCW_OFF	-2.0 to 2.0	0	^F	RW
7	Entering Condenser Water	ECDW			°F	RO
8	ECDW Sensor Raw Temp	ECDW_RAW			°F	RO
9	ECDW Temperature Offset	ECDW_OFF	-2.0 to 2.0	0	^F	RW
10	Leaving Condenser Water	LCDW			°F	RO
11	LCDW Sensor Raw Temp	LCDW_RAW			°F	RO
12	LCDW Temperature Offset	LCDW_OFF	-2.0 to 2.0	0	^F	RW

LEGEND

RO — Read Only
RW — Read/Write

*Default value is shown only if configurable in this table.

APPENDIX A — PIC 6 SCREEN AND TABLE STRUCTURE (cont)

ISM Calibration — J8B 4 to 20 mA Output

CCN TABLE NAME: ISM_CAL1

PIC 6 PATH: Main Menu → Maintenance Menu → ISM Calibration → J8B 4-20mA Output

LINE	PIC 6 DESCRIPTION	CCN NAME	RANGE	DEFAULT VALUE*	UNIT	READ/WRITE
1	J8B 4-20mA Output Cali	cal_en	DSABLE/ENABLE	DSABLE		RW
2	ISM Output mA	ism_ma	4 to 20	0	mA	RW
3	ISM Output Percent	ismo_per	0 to 100	0	%	RO
4	VFD Reading mA	vfd_ma	4 to 20	0	mA	RW
5	VFD Reading Percent	vfdi_per	0 to 100	0	%	RO
6	Calibration Factor	cal_fact	0 to 2000	0		RO
7	Calibration Completed	cal_done	NO/YES	NO		RO

LEGEND

*Default value is shown only if configurable in this table.

RW — Read/Write

RO — Read Only

ISM Calibration — J6 0-10V Input

CCN TABLE NAME: ISM_CAL2

PIC 6 PATH: Main Menu → Maintenance Menu → ISM Calibration → J6 0-10V Input

LINE	PIC 6 DESCRIPTION	CCN NAME	RANGE	DEFAULT VALUE*	UNIT	READ/WRITE
1	J6 0-10V Input Cali	cal_en	DSABLE/ENABLE	DSABLE		RW
2	VFD Output Voltage	vfd_v	0 to 10	0	Volts	RW
3	VFD Output Percent	vfdi_per	0 to 100	0	%	RO
4	ISM Reading Voltage	ism_v	0 to 10	0	Volts	RW
5	ISM Reading Percent	ismi_per	0 to 100	0	%	RO
6	Calibration Factor	cal_fact	800 to 1200	1000		RO
7	Calibration Completed	cal_done	NO/YES	NO		RO

LEGEND

*Default value is shown only if configurable in this table.

RW — Read/Write

RO — Read Only

System Status

CCN TABLE NAME: SYS_STAT

PIC 6 PATH: Main Menu → Maintenance Menu → System Status

LINE	PIC 6 DESCRIPTION	CCN NAME	RANGE	DEFAULT VALUE*	UNIT	READ/WRITE
1	System Control Mode	sys_ctlm				RO
2	System Status	sys_stat				RO
3	Master Run Status	mas_stat				RO
4	Slave Run Status	sla_stat				RO
5	System Percent Load	sys_perl			%	RO
6	System KW	sys_kw			kW	RO
7	System Control Point	sys_stlp			°F	RO
8	System Demand Limit	sys_dem			%	RO
9	Supply Liquid Temp	sys_supt				RO
10	Return Liquid Temp	sys_rent				RO



LEGEND

*Default value is shown only if configurable in this table.

RO — Read Only

APPENDIX A — PIC 6 SCREEN AND TABLE STRUCTURE (cont)

Alarms Menu Description

ICON	DISPLAYED TEXT	ACCESS	ASSOCIATED TABLE	PAGE NO.
	Reset Alarms	All	ALARMRST	96
	Current Alarms	All	CUR_ALM	
	History Alarms	All	ALMHIST1	

Alarm Reset

CCN TABLE NAME: ALARMRST

PIC 6 PATH: Main Menu → Alarm Menu → Alarm Reset

LINE	PIC 6 DESCRIPTION	CCN NAME	RANGE	DEFAULT VALUE*	UNIT	READ/WRITE
1	Alarm Reset	RST_ALM	NO/YES	NO		RW
2	Alarm State	ALM_STAT				RO
3	Current Alarm 1	alarm_1c				RO
4	Current Alarm 2	alarm_2c				RO
5	Current Alarm 3	alarm_3c				RO
6	Current Alarm 4	alarm_4c				RO
7	Current Alarm 5	alarm_5c				RO

LEGEND

RO — Read Only
RW — Read/Write

NOTE: For more information about viewing and resetting alarms, see the Diagnostics and Troubleshooting section on page 38.

*Default value is shown only if configurable in this table.

APPENDIX B — DIP SWITCH SETTINGS

IOB Dip Switch Settings (Fig. E)

19XR2-E		
IOB	SW1 SETTING (1 TO 4)	SW2 SETTING (1 TO 10)
IOB1	0000	0000000001
IOB2	1000	0000000100
IOB3	0100	0000010101
IOB4	1100	0000000110
19XR6/7		
IOB	SW1 SETTING (1 TO 4)	SW2 SETTING (1 TO 10)
IOB-1	0000	0000000000
IOB-2	1000	0000000110
IOB-3	0100	0000010100
IOB-4	1100	0000001000

10000
corresponds to:

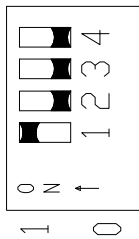

IOB ADDRESS
SW1

0000000110
corresponds to:

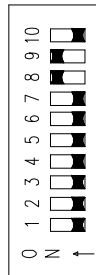

20 mA SHUNT
SW2

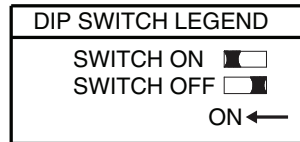

BLACK IS RAISED PORTION
OF SWITCH

Example of Dip Switch Settings

Fig. E — IOB Dip Switch Settings

APPENDIX C — IOB STATUS INDICATORS

All IOB control boards have LED indicators that show control board and communication status.

A red LED on each control module operates in the following manner:

- Power not present or power supply failure: LED is off
- Power present but microprocessor in Reset: LED is off
- Microprocessor operational but not communicating: LED flashes 3 seconds on, 3 seconds off

- Microprocessor operational and communicating with control system: LED flashes at 0.5 Hz rate (1 second on, 1 second off) in sync (± 100 ms) with all other new control modules on the same communication bus
- Microprocessor in boot mode: LED flashes at 0.2 seconds on, 0.2 seconds off

Each independent communication port has a green status LED. The green LED is on when data is being transmitted by the board.

All RS485 ports have a green LED.

APPENDIX D — CONFIGURING BMS PROTOCOL

General: BMS Protocol Configuration

PIC 6 port J8 can be configured for either BACnet MS/TP or Modbus RTU. Selection is made in *Main Menu* → *Configuration Menu* → *Protocol Configuration*.

Upon a changed protocol configuration the PIC 6 module will reboot automatically to save the change.

For BACnet/IP or Modbus TCP/IP use port J15 (Ethernet port 0, default IP: 169.254.0.1, mask: 255.255.0.0). See Fig. F for J15 locations. See Fig G-I for Connect – Protocol Configuration Menu, pages 1-3.

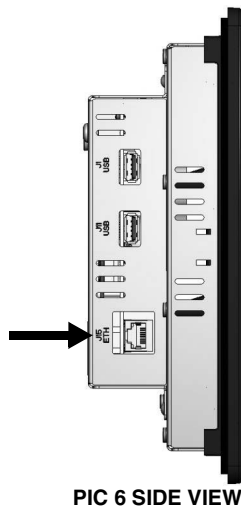
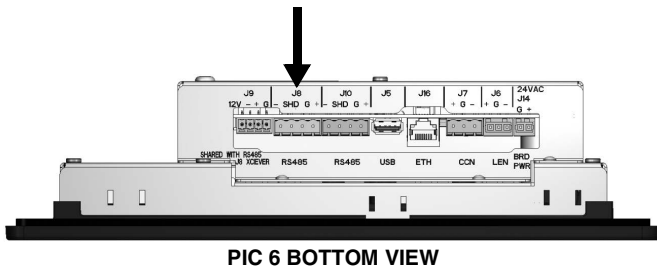

Fig. F — Location of J15 on PIC 6 HMI

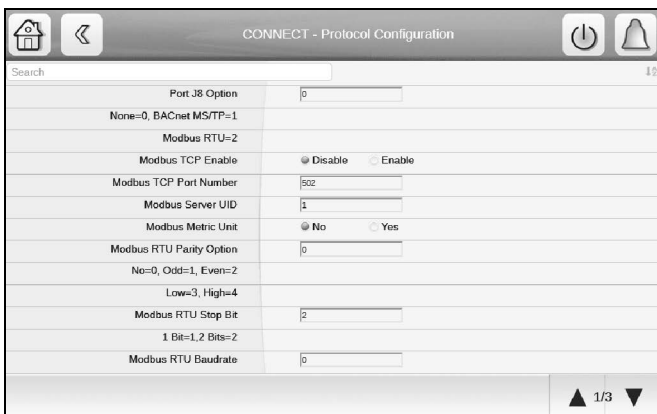

Fig. G — Connect – Protocol Configuration Menu, Page 1

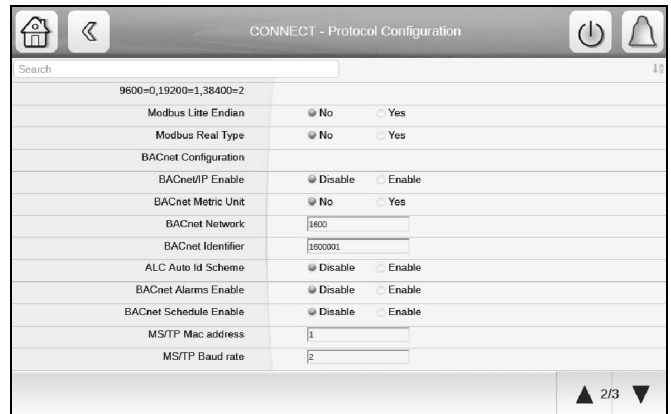

Fig. H — Connect – Protocol Configuration Menu, Page 2

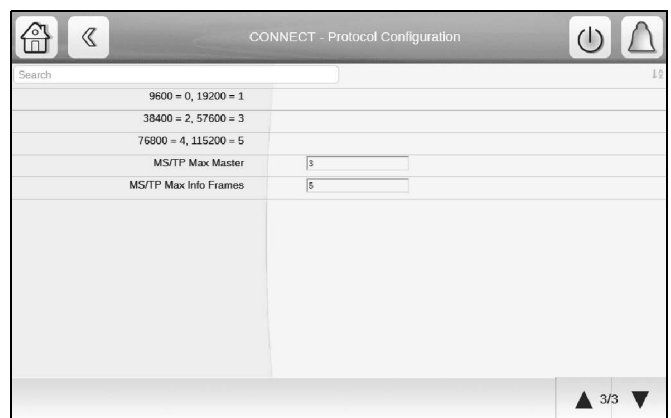

Fig. I — Connect – Protocol Configuration Menu, Page 3

Note that for PIC 6 BACnet MS/TP and Modbus RTU cannot be selected at the same time. Similarly BACnet MS/TP and BACnet IP as well as Modbus RTU and Modbus TCP/IP are mutually exclusive.

BACnet/IP

The 19XR PIC 6 controller supports the BACnet protocol as B-ASC BACnet equipment over IP. In addition, BACnet on the PIC 6 controller supports the following features:

- Optional properties such as Change of Value (COV), Intrinsic Reporting, and Commandable properties on some objects
- The generation of limited alarm and event notifications and the ability to direct them to recipients
- The tracking of acknowledgments of alarms from human operators
- The adjustment of alarm parameters
- Read/write property for many objects

BACnet Settings

BACnet settings are available on the *Main Menu* → *Configuration Menu* → *Protocol Configuration*. The menu requires the Service password for access.

APPENDIX D — CONFIGURING BMS PROTOCOL (cont)

BACnet Objects

The 19XR PIC 6 contains up to 500 BACnet objects. They can be of ANALOG_VALUE (AV) or BINARY_VALUE (BV) type. Objects name are assigned by concatenating the CCN table name and CCN point name. This enables easy identification and recognition of the points. For a detailed list, see the BACnet Object table beginning on page 101.

In general, the equipment configuration parameters are available as Read Only. Setpoint parameters can be read and written (Read-Write).

Compressor status is ASCII-coded. In order to obtain the status from BACnet, statuses are assigned a BACnet code as shown in Table A.

Table A — Equipment Status

BACNET CODE	TEXT
1	Off
2	Control Test
3	Pumpdown
4	Lockout
5	Recycle
6	Tripout
7	Timeout
8	Prestart
9	Startup
10	Autorst
11	Ramping
12	Running
13	Override
14	Demand
15	Shutdown
16	Freecool
17	Condflsh

Alarm states are coded as shown in Table B.

Table B — Alarm States

BACNET CODE	CCN CODE
0	Normal
1	Partial (Alert)
2	Shutdown (Alarm)

Modifying the Unit IP Address

Note that changing IP address from the PIC 6 SETUP menu will require a manual reboot or power cycle of the PIC 6 controller in order to rebuild the BACnet stack. For detailed instructions, see the Unit IP Address section on page 55.

BACnet IP Communication Problems

If the unit does not respond to the building management system, possible causes include the following:

- The Ethernet cable is not correctly connected.
- Network parameters are not correct (see Main Menu, System Configuration for Ethernet configuration and Main Menu, Configuration Menu, Protocol Configuration for appropriate selections.).
- There is an IP router between the equipment and the building management system.
- On the Ethernet connector, verify that the green LED is ON and the orange LED is blinking.
- Use the Windows ping utility to ping the IP address of the controller.
- Open 19XR PIC 6 Configuration Menu (Service password required) and check BACnet parameters.
- Use the free software called BDT (BACnet Discovery Tool) available on the internet (search *bacnet bdt*) and install it on the PC. All equipment connected to the BACnet network will respond to the “Who Is” command sent by this tool. Find the equipment configured with the BACnet device instance (1600001 default for Carrier equipment).

APPENDIX D — CONFIGURING BMS PROTOCOL (cont)

Table C — BACnet Object Table

OBJECT NAME	OBJECT TYPE	INSTANCE	OPTION	COV	PV ACCESS	DESCRIPTION
ALARMRST_alarm_1	AV	85	Type 6	0	RO	Jbus Current Alarm 1
ALARMRST_alarm_2	AV	86	Type 6	0	RO	Jbus Current Alarm 2
ALARMRST_alarm_3	AV	87	Type 6	0	RO	Jbus Current Alarm 3
ALARMRST_alarm_4	AV	88	Type 6	0	RO	Jbus Current Alarm 4
ALARMRST_alarm_5	AV	89	Type 6	0	RO	Jbus Current Alarm 5
BACnet_COLOR	MV	8	Type 5	0	RO	Operation Status Color
BACnet_PRIME_V	AV	150	Type 6	0	RO	Value of Prime variable
CAPACTRL_cm_stat1	AV	95	Type 6	0	RO	Comp1 Run State Val
CAPACTRL_ctrl_wt	AV	90	Type 6	0	RO	Controlled Water Temp
CAPACTRL_gv1_tgt	AV	91	Type 6	0	RO	Target GV1 Pos
CAPACTRL_gv2_tgt	AV	92	Type 6	0	RO	Target GV2 Pos
CAPACTRL_hgbp_tp	AV	94	Type 6	0	RO	EC/HG VLV Target Per
CAPACTRL_vfd_tgt	AV	93	Type 6	0	RO	Target VFD Speed Per
CFGSURGE_gv1_pful	AV	127	Type 6	0	RO	IGV1 Full Load Position
CFGSURGE_gv1_pmin	AV	126	Type 6	0	RO	IGV1 Minimum Position
CFGSURGE_sgl_hoff	AV	130	Type 6	0	RO	Surge Line Upper DB
CFGSURGE_sgl_loff	AV	129	Type 6	0	RO	Surge Line Lower DB
CFGSURGE_sgl_off	AV	128	Type 6	0	RO	Surge Line Offset
CFGSURGE_sgl_pro	AV	134	Type 6	0	RO	Surge Profile Offset
CFGSURGE_sgl_shfh	AV	131	Type 6	0	RO	Surge Line Shape Factor
CFGSURGE_sgl_shfl	AV	132	Type 6	0	RO	Sound Line Shape Factor
CFGSURGE_sgl_spdf	AV	133	Type 6	0	RO	Surge Line Speed Factor
CONF_OPT_hgbp_opt	MV	6	Type 5	0	RO	EC/HG Valve Option
CONF_OPT_hgbp_sel	MV	7	Type 5	0	RO	EC/HG Valve Selection
CONF_PRG_oil_fit	AV	136	Type 6	0	RO	Oil Filter Failure
CONF_PRG_oil_qly	AV	135	Type 6	0	RO	Oil Quality
CONF_PRG_ref_chg	AV	138	Type 6	0	RO	Refrig Charge Status
CONF_PRG_tran_dev	AV	137	Type 6	0	RO	Transducer Deviation
CONNECT_bac_id	AV	140	Type 6	0	RO	BACnet Identifier
CONNECT_bacena	BV	63	Type 4	0	RO	BACnet/IP Enable
CONNECT_bacunit	BV	64	Type 4	0	RO	BACnet Metric Unit
CONNECT_network	AV	139	Type 6	0	RO	BACnet Network
FACTORY_chil_typ	MV	4	Type 5	0	RO	Chiller Type
FACTORY_vfd_opt	MV	5	Type 5	0	RO	VFD/Starter Option
GENUNIT_AMPS_P	AV	4	Type 6	0	RO	Percent Current
GENUNIT_BAC_OCC	BV	9	Type 4	0	RO	BACnet Occupied
GENUNIT_ch_state	AV	7	Type 6	0	RO	Chiller Status Code
GENUNIT_CHIL_OCC_rd	BV	3	Type 4	0	RO	Network:Cmd Occupied
GENUNIT_CHIL_OCC_wr	BV	68	Type 1	0	RW	Chiller occupied?
GENUNIT_CHIL_S_S_rd	BV	2	Type 4	0	RO	Network:Cmd Start/Stop
GENUNIT_CHIL_S_S_wr	BV	66	Type 1	0	RW	Chiller Start/Stop
GENUNIT_ctl_mode	MV	1	Type 5	0	RO	Control Mode
GENUNIT_CTRL_PNT_rd	AV	1	Type 6	0	RO	Control Point
GENUNIT_CTRL_PNT_wr	AV	147	Type 2	0	RW	Control Point
GENUNIT_DEM_LIM_rd	AV	6	Type 6	0	RO	Actual Demand Limit
GENUNIT_DEM_LIM_wr	AV	148	Type 2	0	RW	Demand Limit
GENUNIT_EMSTOP_rd	BV	5	Type 4	0	RO	BMS Emergency Stop
GENUNIT_EMSTOP_wr	BV	67	Type 1	0	RW	BMS Emergency Stop
GENUNIT_FC_START_rd	BV	8	Type 4	0	RO	Start Free Cooling
GENUNIT_FC_START_wr	BV	69	Type 1	0	RW	Start Free Cooling
GENUNIT_HC_SEL_rd	BV	4	Type 4	0	RO	Cooling/Heating Select
GENUNIT_HC_SEL_wr	AV	149	Type 2	0	RW	Heatcool Select
GENUNIT_ice_occ	BV	7	Type 4	0	RO	Ice Schedule Occupied
GENUNIT_KW_P	AV	5	Type 6	0	RO	Motor Percent Kilowatts
GENUNIT_loc_occ	BV	6	Type 4	0	RO	Local Schedule Occupied
GENUNIT_reset	AV	2	Type 6	0	RO	Control Point Reset
GENUNIT_setpoint	AV	3	Type 6	0	RO	Actual Setpoint
GENUNIT_statstop	BV	1	Type 4	0	RO	Deter Start Stop Command
HYDRLIC_CDW_FLOW	BV	50	Type 4	0	RO	Condenser Water Flow
HYDRLIC_CDW_FV	AV	58	Type 6	0	RO	Cond Water Flow Value

APPENDIX D — CONFIGURING BMS PROTOCOL (cont)

Table C — BACnet Object Table (cont)

OBJECT NAME	OBJECT TYPE	INSTANCE	OPTION	COV	PV ACCESS	DESCRIPTION
HYDRLIC_cdw_pd	AV	59	Type 6	0	RO	Condenser Water Delta P
HYDRLIC_CDWP	BV	49	Type 4	0	RO	Condenser Water Pump
HYDRLIC_CHW_FLOW	BV	52	Type 4	0	RO	Chilled Water Flow
HYDRLIC_chw_fv	AV	60	Type 6	0	RO	Chilled Water Flow Value
HYDRLIC_chw_pd	AV	61	Type 6	0	RO	Chilled Water Delta P
HYDRLIC_CHWP	BV	51	Type 4	0	RO	Chilled Water Pump
HYDRLIC_ctrlw_dt	AV	62	Type 6	0	RO	Controlled Water DT
INPUTS_DIFF_ACT	AV	47	Type 6	0	RO	Diffuser Actual Pos
INPUTS_DMP_ACT	MV	2	Type 5	0	RO	ECO DMP VLV Status
INPUTS_E_STOP	BV	13	Type 4	0	RO	Emergency Stop Contact
INPUTS_FS_LOCK	BV	18	Type 4	0	RO	Fire Security Interlock
INPUTS_GV1_ACT	AV	44	Type 6	0	RO	Guide Vane 1 Actual Pos
INPUTS_GV2_ACT	AV	45	Type 6	0	RO	Guide Vane 2 Actual Pos
INPUTS_HF_LS	BV	23	Type 4	0	RO	Liquid Level Switch
INPUTS_HGBP_ACT	MV	3	Type 5	0	RO	EC/HG VLV Status
INPUTS_HGBPACTP	AV	48	Type 6	0	RO	EC/HG VLV Actual Pos Per
INPUTS_HP_SW	BV	11	Type 4	0	RO	High Pressure Switch
INPUTS_ICE_CON	BV	14	Type 4	0	RO	Ice Build Contact
INPUTS_PGLE_HI	BV	22	Type 4	0	RO	Purge Level Switch High
INPUTS_PGLE_LO	BV	21	Type 4	0	RO	Purge Level Switch Low
INPUTS_REM_CON	BV	12	Type 4	0	RO	Remote Start/Stop
INPUTS_REM_LOCK	BV	15	Type 4	0	RO	Chiller Lockout
INPUTS_SAFETY	BV	16	Type 4	0	RO	Spare Safety Input
INPUTS_STAR_AUX	BV	10	Type 4	0	RO	Compressor Start Contact
INPUTS_STARTFLT	BV	17	Type 4	0	RO	Starter Fault Feedback
INPUTS_TRIPR	BV	19	Type 4	0	RO	ISM Trip Relay Status
INPUTS_VFD_ACT	AV	46	Type 6	0	RO	Actual VFD Speed Per
LABONLY_gv1_fc	BV	61	Type 4	0	RO	GV1 Forced
LABONLY_gv2_fc	BV	62	Type 4	0	RO	GV2 Forced
MAIN_MS_lag_s_s	BV	60	Type 4	0	RO	Slave Start/Stop
MAIN_MS_lagstart	AV	121	Type 6	0	RO	Lag Start Timer
MAIN_MS_lagstat	AV	120	Type 6	0	RO	Slave Run Status
MAIN_MS_lagstop	AV	122	Type 6	0	RO	Lag Stop Timer
MAIN_MS_lead_lag	AV	116	Type 6	0	RO	Unit is Lead or Lag
MAIN_MS_ll_comm	BV	59	Type 4	0	RO	Lead Lag Communication
MAIN_MS_ll_fault	AV	119	Type 6	0	RO	Master Slave Fault
MAIN_MS_ll_hr_d	AV	125	Type 6	0	RO	Lead/Lag Hours Delta
MAIN_MS_ms_ctrl	AV	117	Type 6	0	RO	Master Control Type
MAIN_MS_prefit	AV	123	Type 6	0	RO	Prestart Fault Timer
MAIN_MS_pulltime	AV	124	Type 6	0	RO	Pulldown Timer
MAIN_MS_sl_ctrl	AV	118	Type 6	0	RO	Slave Control Type
MAIN_SRD_diff_alm	BV	58	Type 4	0	RO	SRD Rotating Stall Alarm
MAIN_SRD_diff_tgt	AV	112	Type 6	0	RO	Diffuser Target Pos
MAIN_SRD_diffault	BV	57	Type 4	0	RO	Diffuser Fault
MAIN_SRD_lift_1	AV	114	Type 6	0	RO	VDO High Lift Load Line
MAIN_SRD_lift_2	AV	115	Type 6	0	RO	VDO Low Lift Load Line
MAIN_SRD_lift_a	AV	113	Type 6	0	RO	Actual Lift
MAISURGE_act_reg	AV	96	Type 6	0	RO	Surge Region
MAISURGE_dts_act	AV	97	Type 6	0	RO	Actual Delta Tsat
MAISURGE_dts_cal	AV	98	Type 6	0	RO	Calc Ref Delta Tsat
MAISURGE_dts_maxc	AV	103	Type 6	0	RO	Cal Surge Delta Tsmax
MAISURGE_dts_medc	AV	105	Type 6	0	RO	Cal Surge Delta Tsmed
MAISURGE_dts_minc	AV	104	Type 6	0	RO	Cal Surge Delta Tsmin
MAISURGE_enlp_opt	AV	109	Type 6	0	RO	Envelope Line/HG Opt.
MAISURGE_gv1_sful	AV	106	Type 6	0	RO	IGV1 Full Load Position
MAISURGE_gv1_smed	AV	108	Type 6	0	RO	Opti-Sound IGV1 Position
MAISURGE_gv1_smin	AV	107	Type 6	0	RO	IGV1 Minimum Position
MAISURGE_sc	AV	99	Type 6	0	RO	Surge Counts
MAISURGE_spc	AV	100	Type 6	0	RO	Surge Protection Counts
MAISURGE_surg_act	AV	101	Type 6	0	RO	Surge Prevention Active
MAISURGE_surg_pro	AV	102	Type 6	0	RO	Surge Protection Active

APPENDIX D — CONFIGURING BMS PROTOCOL (cont)

Table C — BACnet Object Table (cont)

OBJECT NAME	OBJECT TYPE	INSTANCE	OPTION	COV	PV ACCESS	DESCRIPTION
MODES_cm_stat1	MV	9	Type 5	0	RO	Comp1 Run State Val
OUTPUTS_ALE	BV	25	Type 4	0	RO	Alert Relay
OUTPUTS_ALM	BV	24	Type 4	0	RO	Alarm Relay
OUTPUTS_CHST_OUT	AV	51	Type 6	0	RO	Chiller Status (Analog)
OUTPUTS_COMP_PSV	BV	39	Type 4	0	RO	Purge Comp Valve
OUTPUTS_COMP_SR	BV	26	Type 4	0	RO	Compressor Start Relay
OUTPUTS_COND_CV	BV	34	Type 4	0	RO	Cond Valve (Ref Lube)
OUTPUTS_COND_DCV	BV	37	Type 4	0	RO	Condenser Drain Valve
OUTPUTS_COND_FCV	BV	48	Type 4	0	RO	Cond Charging (Ref Lube)
OUTPUTS_COND_PSV	BV	38	Type 4	0	RO	Purge Cond Valve
OUTPUTS_DIFF_OUT	AV	49	Type 6	0	RO	Diffuser Output mA
OUTPUTS_DIS_PSV	BV	42	Type 4	0	RO	Purge Discharge Valve
OUTPUTS_DRASVON	BV	40	Type 4	0	RO	Purge Drainage Valve
OUTPUTS_ECON_IV	BV	33	Type 4	0	RO	ECO Isolation VLV
OUTPUTS_EVAP_CV	BV	35	Type 4	0	RO	Evap Valve (Ref Lube)
OUTPUTS_EVAP_DCV	BV	36	Type 4	0	RO	Evaporator Drain Valve
OUTPUTS_EXV_OUT	AV	53	Type 6	0	RO	Oil Cooler EXV mA
OUTPUTS_FC_VALVE	BV	47	Type 4	0	RO	Free Cooling Valve
OUTPUTS_GV1_DEC	BV	27	Type 4	0	RO	Guide Vane 1 Decrease
OUTPUTS_GV1_INC	BV	28	Type 4	0	RO	Guide Vane 1 Increase
OUTPUTS_GV1_OUT	AV	56	Type 6	0	RO	Guide Vane1 Output
OUTPUTS_GV2_OUT	AV	57	Type 6	0	RO	Guide Vane2 Output
OUTPUTS_HDPV_OUT	AV	50	Type 6	0	RO	Head Pres Output mA
OUTPUTS_llc_exvt	AV	54	Type 6	0	RO	Liquid Level EXV Target
OUTPUTS_OIL_HEAT	BV	29	Type 4	0	RO	Oil Heater Relay
OUTPUTS_OIL_PUMP	BV	30	Type 4	0	RO	Oil Pump Relay
OUTPUTS_op_vfd_t	AV	55	Type 6	0	RO	Oil Pump VFD Target
OUTPUTS_PG_COMP	BV	44	Type 4	0	RO	Purge Compressor
OUTPUTS_PG_HEAT	BV	45	Type 4	0	RO	Purge Heater
OUTPUTS_PGAPUMP	BV	43	Type 4	0	RO	Purge Vacuum Pump
OUTPUTS_REG_PSV	BV	41	Type 4	0	RO	Purge Regeneration Valve
OUTPUTS_RUN_STAT	BV	70	Type 4	0	RO	Chiller Status(Discrete)
OUTPUTS_TFR_HIGH	BV	31	Type 4	0	RO	Tower Fan Relay High
OUTPUTS_TFR_LOW	BV	32	Type 4	0	RO	Tower Fan Relay Low
OUTPUTS_VFD_OUT	AV	52	Type 6	0	RO	VFD Speed Output mA
OUTPUTS_VS_SV	BV	46	Type 4	0	RO	Vapor Source SV
POWER_I_AMPS_A_I	AV	66	Type 6	0	RO	Actual Line Current
POWER_I_AMPS_P_I	AV	67	Type 6	0	RO	Percent Line Current
POWER_I_KW	AV	70	Type 6	0	RO	Line Kilowatts
POWER_I_KWH	AV	156	Type 6	0	RO	Line Kilowatts Hours
POWER_I_In_imb_i	AV	152	Type 6	0	RO	Line Current Imbalance%
POWER_I_In_imb_v	AV	72	Type 6	0	RO	Line Voltage Imbalance%
POWER_I_POW_FACT	AV	71	Type 6	0	RO	Line Power Factor
POWER_I_VOLT_A	AV	68	Type 6	0	RO	Actual Line Voltage
POWER_I_VOLT_P	AV	69	Type 6	0	RO	Percent Line Voltage
POWER_O_alm_code	AV	84	Type 6	0	RO	VFD Alarm Code
POWER_O_amps_p_o	AV	74	Type 6	0	RO	Percent VFD Load Current
POWER_O_bus_volt	AV	76	Type 6	0	RO	DC Bus Voltage
POWER_O_enc_temp	AV	81	Type 6	0	RO	VFD Enclosure Temp
POWER_O_inv_temp	AV	82	Type 6	0	RO	Inverter Temperature
POWER_O_lrtem_sw	BV	54	Type 4	0	RO	LR Temp Switch
POWER_O_MOT_FREQ	AV	75	Type 6	0	RO	Motor Actual Frequency
POWER_O_motor_kw	AV	79	Type 6	0	RO	Motor Kilowatts
POWER_O_motor_pf	AV	78	Type 6	0	RO	Motor Power Factor
POWER_O_motorkwh	AV	80	Type 6	0	RO	Motor Kilowatt-Hours
POWER_O_prech_fd	BV	53	Type 4	0	RO	Precharge Feedback
POWER_O_rec_temp	AV	83	Type 6	0	RO	Rectifier Temperature
POWER_O_spd_fd	BV	55	Type 4	0	RO	SPD Feedback
POWER_O_vfd_act	AV	77	Type 6	0	RO	Actual VFD Speed Per
POWER_O_VFD_LOAD	AV	73	Type 6	0	RO	VFD Load Current
POWER_O_VFDC_HI	BV	56	Type 4	0	RO	High VFD Current

APPENDIX D — CONFIGURING BMS PROTOCOL (cont)

Table C — BACnet Object Table (cont)

OBJECT NAME	OBJECT TYPE	INSTANCE	OPTION	COV	PV ACCESS	DESCRIPTION
PRESSURE_COND_P	AV	37	Type 6	0	RO	Condenser Pressure
PRESSURE_DIFF_P	AV	40	Type 6	0	RO	Diffuser Pressure
PRESSURE_ECON_P	AV	38	Type 6	0	RO	Economizer Pressure
PRESSURE_EVAP_P	AV	36	Type 6	0	RO	Evaporator Pressure
PRESSURE_HEAD_P	AV	41	Type 6	0	RO	Head Pressure Reference
PRESSURE_OIL_PD	AV	39	Type 6	0	RO	Oil Pump Delta P
PRESSURE_PUMP_PD	AV	43	Type 6	0	RO	Ref Pump Delta P
PRESSURE_REF_PD	AV	42	Type 6	0	RO	Bearing Delta P
QCK_TEST_Q_DIFTGT	AV	111	Type 6	0	RO	Diffuser Target Pos
QCK_TEST_Q_GV1ACT	AV	110	Type 6	0	RO	Guide Vane 1 Actual Pos
RUNTIME_C_STARTS	AV	63	Type 6	0	RO	Compressor Starts Num
RUNTIME_COMP_HRS	AV	64	Type 6	0	RO	Comp Total Running Hrs
RUNTIME_PGP_NO	AV	153	Type 6	0	RO	Total Pumpout Numbers
RUNTIME_PGP_TM	AV	154	Type 6	0	RO	Total Pumpout Time
RUNTIME_pgp_tm_w	AV	155	Type 6	0	RO	Avg Daily Purge in 7 Day
RUNTIME_SRV_HRS	AV	65	Type 6	0	RO	After Service Hrs
RUNTIME_ST_CNT12	AV	151	Type 6	0	RO	Starts Num in 12 Hours
SETPOINT_dem_base	AV	146	Type 6	0	RW	Base Demand Limit
SETPOINT_ecdw_sp	AV	143	Type 6	0	RW	Heating ECDW Setpoint
SETPOINT_ecw_sp	AV	141	Type 6	0	RW	Cooling ECW Setpoint
SETPOINT_EWT_OPT	BV	65	Type 4	0	RW	EWT Control Option
SETPOINT_ice_sp	AV	145	Type 6	0	RW	Ice Build Setpoint
SETPOINT_lcdw_sp	AV	144	Type 6	0	RW	Heating LCDW Setpoint
SETPOINT_lcw_sp	AV	142	Type 6	0	RW	Cooling LCW Setpoint
TEMP_CBH1_T	AV	33	Type 6	0	RO	1st Stage Bearing Temp
TEMP_CBH2_T	AV	34	Type 6	0	RO	2nd Stage Bearing Temp
TEMP_cond_app	AV	17	Type 6	0	RO	Condenser Approach
TEMP_COND_SAT	AV	18	Type 6	0	RO	Cond Sat Refrig Temp
TEMP_DGT	AV	19	Type 6	0	RO	Comp Discharge Temp
TEMP_DSH	AV	20	Type 6	0	RO	Discharge Superheat
TEMP_ECDW	AV	10	Type 6	0	RO	Entering Condenser Water
TEMP_ECW	AV	8	Type 6	0	RO	Entering Chilled Water
TEMP_evap_app	AV	16	Type 6	0	RO	Evaporator Approach
TEMP_EVAP_SAT	AV	14	Type 6	0	RO	Evap Sat Refrig Temp
TEMP_EVAP_T	AV	15	Type 6	0	RO	Evap Refrig Liquid Temp
TEMP_HR_EWT	AV	12	Type 6	0	RO	Heat Recl Entering Temp
TEMP_HR_LWT	AV	13	Type 6	0	RO	Heat Recl Leaving Temp
TEMP_LCDW	AV	11	Type 6	0	RO	Leaving Condenser Water
TEMP_LCW	AV	9	Type 6	0	RO	Leaving Chilled Water
TEMP_MTRB	AV	22	Type 6	0	RO	Thrust Bearing Temp
TEMP_MTRB_OIL	AV	21	Type 6	0	RO	Thrust Bearing Oil Temp
TEMP_MTRB1	AV	23	Type 6	0	RO	Low Speed ME Brg Temp
TEMP_MTRB2	AV	24	Type 6	0	RO	Low Speed CE Brg Temp
TEMP_MTRB3	AV	25	Type 6	0	RO	High Speed ME Brg Temp
TEMP_MTRB4	AV	26	Type 6	0	RO	High Speed CE Brg Temp
TEMP_MTRW1	AV	27	Type 6	0	RO	Motor Winding 1 Temp
TEMP_MTRW2	AV	28	Type 6	0	RO	Motor Winding 2 Temp
TEMP_MTRW3	AV	29	Type 6	0	RO	Motor Winding 3 Temp
TEMP_OILT_DIS	AV	31	Type 6	0	RO	Oil Supply Temp
TEMP_OILT_SMP	AV	30	Type 6	0	RO	Oil Sump Temp
TEMP_PGC_SUCT	AV	32	Type 6	0	RO	Purge Comp Suction Temp

LEGEND

AV — Analog Value
 BV — Binary Value
 CMD — Commandable
 COV — Change of Value
 MV — Multi-State Value
 IR — Intrinsic Reporting
 RO — Read Only
 RW — Read/Write

APPENDIX D — CONFIGURING BMS PROTOCOL (cont)

Table D — Modbus Point Table

ADDRESS		REG. N°	PARAMETER	DESCRIPTION	DISPLAY MODE	TYPE	UNIT	VALUE			COMMENT
HEXADEC.	DEC.							MIN.	MAX.	DEFAULT	
0X0FA0	4000	2	GENUNIT_ctl_mode	Control Mode	32bits UINT	IR		0	3	0	
0X07D0	2000	1	GENUNIT_statstop	Deter Start Stop Command	1bit BOOL	DI		0	1	0	
0X07D1	2001	1	GENUNIT_CHIL_S_S	Network:Cmd Start/Stop	1bit BOOL	DI		0	1	0	
0X07D2	2002	1	GENUNIT_CHIL_OCC	Network:Cmd Occupied	1bit BOOL	DI		0	1	0	
0X0FA2	4002	2	GENUNIT_HC_SEL	Cooling/Heating Select	32bits UINT	IR		0	1	0	
0X0FA4	4004	2	GENUNIT_CTRL_PNT	Control Point	32bits FLOAT	IR	°F °C	10 -12.222222	160 71.111118	10 -12.222222	
0X0FA6	4006	2	GENUNIT_AMPS_P	Percent Current	32bits FLOAT	IR	%			0	
0X0FA8	4008	2	GENUNIT_KW_P	Motor Percent Kilowatts	32bits FLOAT	IR	%			0	
0X0FAA	4010	2	GENUNIT_DEM_LIM	Actual Demand Limit	32bits FLOAT	IR	%	10	100	10	
0X07D3	2003	1	GENUNIT_EMSTOP	BMS Emergency Stop	1bit BOOL	DI		0	1	0	
0X07D4	2004	1	GENUNIT_FC_START	Start Free Cooling	1bit BOOL	DI		0	1	0	
0X0FAC	4012	2	GENUNIT_ch_state	Chiller Status Code	32bits UINT	IR				0	
0X07D5	2005	1	GENUNIT_loc_occ	Local Schedule Occupied	1bit BOOL	DI		0	1	0	
0X07D6	2006	1	GENUNIT_ice_occ	Ice Schedule Occupied	1bit BOOL	DI		0	1	0	
0X0FAE	4014	2	TEMP_ECW	Entering Chilled Water	32bits FLOAT	IR	°F °C			0 -17.777778	
0X0FB0	4016	2	TEMP_LCW	Leaving Chilled Water	32bits FLOAT	IR	°F °C			0 -17.777778	
0X0FB2	4018	2	TEMP_ECDW	Entering Condenser Water	32bits FLOAT	IR	°F °C			0 -17.777778	
0X0FB4	4020	2	TEMP_LCDW	Leaving Condenser Water	32bits FLOAT	IR	°F °C			0 -17.777778	
0X109C	4252	2	TEMP_HR_EWT	Heat Recl Entering Temp	32bits FLOAT	IR	°F °C			0 -17.777778	
0X109E	4254	2	TEMP_HR_LWT	Heat Recl Leaving Temp	32bits FLOAT	IR	°F °C			0 -17.777778	
0X0FB6	4022	2	TEMP_EVAP_SAT	Evap Sat Refrig Temp	32bits FLOAT	IR	°F °C			0 -17.777778	
0X0FB8	4024	2	TEMP_EVAP_T	Evap Refrig Liquid Temp	32bits FLOAT	IR	°F °C			0 -17.777778	
0X0FBA	4026	2	TEMP_evap_app	Evaporator Approach	32bits FLOAT	IR	°F °C				
0X0FBC	4028	2	TEMP_cond_app	Condenser Approach	32bits FLOAT	IR	°F °C				
0X0FBE	4030	2	TEMP_COND_SAT	Cond Sat Refrig Temp	32bits FLOAT	IR	°F °C			0 -17.777778	
0X0FC0	4032	2	TEMP_DGT	Comp Discharge Temp	32bits FLOAT	IR	°F °C			0 -17.777778	
0X0FC2	4034	2	TEMP_DSH	Discharge Superheat	32bits FLOAT	IR	°F °C				
0X0FC4	4036	2	TEMP_MTRB_OIL	Thrust Bearing Oil Temp	32bits FLOAT	IR	°F °C			0 -17.777778	
0X0FC6	4038	2	TEMP_MTRB	Thrust Bearing Temp	32bits FLOAT	IR	°F °C			0 -17.777778	
0X0FC8	4040	2	TEMP_MTRB1	Low Speed ME Brg Temp	32bits FLOAT	IR	°F °C			0 -17.777778	
0X0FCA	4042	2	TEMP_MTRB2	Low Speed CE Brg Temp	32bits FLOAT	IR	°F °C			0 -17.777778	
0X0FCC	4044	2	TEMP_MTRB3	High Speed ME Brg Temp	32bits FLOAT	IR	°F °C			0 -17.777778	
0X0FCE	4046	2	TEMP_MTRB4	High Speed CE Brg Temp	32bits FLOAT	IR	°F °C			0 -17.777778	
0X0FD0	4048	2	TEMP_MTRW1	Motor Winding 1 Temp	32bits FLOAT	IR	°F °C			0 -17.777778	
0X0FD2	4050	2	TEMP_MTRW2	Motor Winding 2 Temp	32bits FLOAT	IR	°F °C			0 -17.777778	
0X0FD4	4052	2	TEMP_MTRW3	Motor Winding 3 Temp	32bits FLOAT	IR	°F °C			0 -17.777778	
0X0FD6	4054	2	TEMP_CBH1_T	1st Stage Bearing Temp	32bits FLOAT	IR	°F °C			0 -17.777778	
0X0FD8	4056	2	TEMP_CBH2_T	2nd Stage Bearing Temp	32bits FLOAT	IR	°F °C			0 -17.777778	
0X0FDC	4060	2	TEMP_OILT_SMP	Oil Sump Temp	32bits FLOAT	IR	°F °C			0 -17.777778	
0X0FDE	4062	2	TEMP_OILT_DIS	Oil Supply Temp	32bits FLOAT	IR	°F °C			0 -17.777778	
0X0FE0	4064	2	TEMP_PGC_SUCT	Purge Comp Suction Temp	32bits FLOAT	IR	°F °C			0 -17.777778	
0X0FE4	4068	2	PRESSURE_EVAP_P	Evaporator Pressure	32bits FLOAT	IR	PSIG kPa				
0X0FE6	4070	2	PRESSURE_COND_P	Condenser Pressure	32bits FLOAT	IR	PSIG kPa				
0X0FE8	4072	2	PRESSURE_ECON_P	Economizer Pressure	32bits FLOAT	IR	PSIG kPa				

APPENDIX D — CONFIGURING BMS PROTOCOL (cont)

Table D — Modbus Point Table (cont)

ADDRESS		REG. N°	PARAMETER	DESCRIPTION	DISPLAY MODE	TYPE	UNIT	VALUE			COMMENT
HEXADEC.	DEC.							MIN.	MAX.	DEFAULT	
0X0FEA	4074	2	PRESSURE_OIL_PD	Oil Pump Delta P	32bits FLOAT	IR	PSIG kPa				
0X0FEC	4076	2	PRESSURE_REF_PD	Bearing Delta P	32bits FLOAT	IR	PSIG kPa				
0X0FEE	4078	2	PRESSURE_PUMP_PD	Ref Pump Delta P	32bits FLOAT	IR	PSIG kPa				
0X0FF0	4080	2	PRESSURE_DIFF_P	Diffuser Pressure	32bits FLOAT	IR	PSIG kPa				
0X0FF2	4082	2	PRESSURE_HEAD_P	Head Pressure Reference	32bits FLOAT	IR	PSIG kPa				
0X07D7	2007	1	INPUTS_STAR_AUX	Compressor Start Contact	1bit BOOL	DI		0	1	0	
0X0FF4	4084	2	INPUTS_DMP_ACT	ECO DMP VLV Status	32bits UINT	IR				0	
0X0FF6	4086	2	INPUTS_HGBP_ACT	EC/HG VLV Status	32bits UINT	IR				0	
0X07D8	2008	1	INPUTS_HP_SW	High Pressure Switch	1bit BOOL	DI		0	1	0	
0X07D9	2009	1	INPUTS_REM_CON	Remote Start/Stop	1bit BOOL	DI		0	1	0	
0X07DA	2010	1	INPUTS_E_STOP	Emergency Stop Contact	1bit BOOL	DI		0	1	0	
0X07DB	2011	1	INPUTS_ICE_CON	Ice Build Contact	1bit BOOL	DI		0	1	0	
0X07DC	2012	1	INPUTS_REM_LOCK	Chiller Lockout	1bit BOOL	DI		0	1	0	
0X07DD	2013	1	INPUTS_SAFETY	Spare Safety Input	1bit BOOL	DI		0	1	0	
0X07DE	2014	1	INPUTS_STARTFLT	Starter Fault Feedback	1bit BOOL	DI		0	1	0	
0X07DF	2015	1	INPUTS_FS_LOCK	Fire Security Interlock	1bit BOOL	DI		0	1	0	
0X0FF8	4088	2	INPUTS_HGBPACTP	EC/HG VLV Actual Pos Per	32bits FLOAT	IR	%			0	
0X0FFC	4092	2	INPUTS_GV1_ACT	Guide Vane 1 Actual Pos	32bits FLOAT	IR	%			0	
0X0FFE	4094	2	INPUTS_GV2_ACT	Guide Vane 2 Actual Pos	32bits FLOAT	IR	%			0	
0X1000	4096	2	INPUTS_VFD_ACT	Actual VFD Speed Per	32bits FLOAT	IR	%			0	
0X07E2	2018	1	INPUTS_TRIPR	ISM Trip Relay Status	1bit BOOL	DI		0	1	0	
0X1002	4098	2	OUTPUTS_CHST_OUT	Chiller Status (Analog)	32bits FLOAT	IR	mA			0	
0X1004	4100	2	OUTPUTS_exv_tgt	Oil Cooler EXV Target	32bits FLOAT	IR	%			0	
0X1008	4104	2	OUTPUTS_hdpv_tgt	Head Pres Valve Tgt Pos	32bits FLOAT	IR	%			0	
0X07E3	2019	1	OUTPUTS_ALM	Alarm Relay	1bit BOOL	DI		0	1	0	
0X07E4	2020	1	OUTPUTS_ALE	Alert Relay	1bit BOOL	DI		0	1	0	
0X07E5	2021	1	OUTPUTS_COMP_SR	Compressor Start Relay	1bit BOOL	DI		0	1	0	
0X07E6	2022	1	OUTPUTS_GV1_DEC	Guide Vane 1 Decrease	1bit BOOL	DI		0	1	0	
0X07E7	2023	1	OUTPUTS_GV1_INC	Guide Vane 1 Increase	1bit BOOL	DI		0	1	0	
0X07E8	2024	1	OUTPUTS_OIL_HEAT	Oil Heater Relay	1bit BOOL	DI		0	1	0	
0X07E9	2025	1	OUTPUTS_OIL_PUMP	Oil Pump Relay	1bit BOOL	DI		0	1	0	
0X07EA	2026	1	OUTPUTS_TFR_HIGH	Tower Fan Relay High	1bit BOOL	DI		0	1	0	
0X07EB	2027	1	OUTPUTS_TFR_LOW	Tower Fan Relay Low	1bit BOOL	DI		0	1	0	
0X07EF	2031	1	OUTPUTS_COND_PSV	Purge Cond Valve	1bit BOOL	DI		0	1	0	
0X07F0	2032	1	OUTPUTS_COMP_PSV	Purge Comp Valve	1bit BOOL	DI		0	1	0	
0X07F1	2033	1	OUTPUTS_PUMP_PSV	Purge Pumpout Valve	1bit BOOL	DI		0	1	0	
0X07F3	2035	1	OUTPUTS_REG_PSV	Purge Regeneration Valve	1bit BOOL	DI		0	1	0	
0X07F4	2036	1	OUTPUTS_DIS_PSV	Purge Discharge Valve	1bit BOOL	DI		0	1	0	
0X07F5	2037	1	OUTPUTS_PGAPUMP	Purge Vacuum Pump	1bit BOOL	DI		0	1	0	
0X07F6	2038	1	OUTPUTS_PG_COMP	Purge Compressor	1bit BOOL	DI		0	1	0	
0X07F7	2039	1	OUTPUTS_PG_HEAT	Purge Heater	1bit BOOL	DI		0	1	0	
0X100A	4106	2	OUTPUTS_llc_exvt	Liquid Level EXV Target	32bits FLOAT	IR	%			0	
0X07F8	2040	1	OUTPUTS_FC_VALVE	Free Cooling Valve	1bit BOOL	DI		0	1	0	
0X100E	4110	2	OUTPUTS_HGBP_OUT	EC/HG VLV Output mA	32bits FLOAT	IR	mA			0	
0X07F9	2041	1	HYDRLIC_CDWP	Condenser Water Pump	1bit BOOL	DI		0	1	0	
0X1010	4112	2	HYDRLIC_cdw_pd	Condenser Water Delta P	32bits FLOAT	IR	PSIG kPa				
0X07FA	2042	1	HYDRLIC_CHWP	Chilled Water Pump	1bit BOOL	DI		0	1	0	
0X1012	4114	2	HYDRLIC_chw_pd	Chilled Water Delta P	32bits FLOAT	IR	PSIG kPa				
0X1014	4116	2	HYDRLIC_CDW_FV	Cond Water Flow Value	32bits FLOAT	IR	GPM l/min			0	
0X1016	4118	2	HYDRLIC_CHW_FV	Chilled Water Flow Value	32bits FLOAT	IR	GPM l/min			0	
0X1018	4120	2	RUNTIME_C_STARTS	Compressor Starts Num	32bits UINT	IR		0	65535	0	
0X101A	4122	2	RUNTIME_SRV_HRS	After Service Hrs	32bits FLOAT	IR	hour	0	500000	0	
0X1096	4246	2	RUNTIME_ST_CNT12	Starts Num in 12 Hours	32bits UINT	IR				0	
0X1090	4240	2	RUNTIME_PGP_NO	Total Pumpout Numbers	32bits UINT	IR				0	
0X1092	4242	2	RUNTIME_PGP_TM	Total Pumpout Time	32bits UINT	IR	minute			0	
0X1094	4244	2	RUNTIME_pgp_tm_w	Avg Daily Purge in 7 Day	32bits FLOAT	IR	minute			0	
0X101C	4124	2	ALARMRST_alarm_1	Jbus Current Alarm 1	32bits UINT	IR				0	
0X101E	4126	2	ALARMRST_alarm_2	Jbus Current Alarm 2	32bits UINT	IR				0	
0X1020	4128	2	ALARMRST_alarm_3	Jbus Current Alarm 3	32bits UINT	IR				0	
0X1022	4130	2	ALARMRST_alarm_4	Jbus Current Alarm 4	32bits UINT	IR				0	

APPENDIX D — CONFIGURING BMS PROTOCOL (cont)

Table D — Modbus Point Table (cont)

ADDRESS		REG. N°	PARAMETER	DESCRIPTION	DISPLAY MODE	TYPE	UNIT	VALUE			COMMENT
HEXADEC.	DEC.							MIN.	MAX.	DEFAULT	
0X1024	4132	2	ALARMRST_alarm_5	Jbus Current Alarm 5	32bits UINT	IR				0	
0X1026	4134	2	CAPACTRL_ctrl_wt	Controlled Water Temp	32bits FLOAT	IR	°F °C			0 -17.777778	
0X1028	4136	2	CAPACTRL_cm_stat1	Comp1 Run State Val	32bits UINT	IR				0	
0X102A	4138	2	CAPACTRL_vfd_tgt	Target VFD Speed Per	32bits UINT	IR	%			0	
0X102C	4140	2	CAPACTRL_gv1_tgt	Target GV1 Pos	32bits FLOAT	IR	%			0	
0X102E	4142	2	CAPACTRL_gv2_tgt	Target GV2 Pos	32bits FLOAT	IR	%			0	
0X1030	4144	2	CAPACTRL_hgbp_tp	EC/HG VLV Target Per	32bits FLOAT	IR	%			0	
0X1032	4146	2	MAISURGE_act_reg	Surge Region	32bits UINT	IR				0	
0X1034	4148	2	MAISURGE_sc	Surge Counts	32bits UINT	IR				0	
0X1036	4150	2	MAISURGE_surg_act	Surge Prevention Active	32bits UINT	IR		0	1	0	
0X1038	4152	2	MAISURGE_spc	Surge Protection Counts	32bits UINT	IR				0	
0X103A	4154	2	MAISURGE_surg_pro	Surge Protection Active	32bits UINT	IR		0	1	0	
0X103C	4156	2	MAISURGE_dts_act	Actual Delta Tsat	32bits FLOAT	IR	°F °C			0 0	
0X103E	4158	2	MAISURGE_dts_cal	Calc Ref Delta Tsat	32bits FLOAT	IR	°F °C			0 0	
0X1040	4160	2	MAIN_SRD_diff_tgt	Diffuser Target Pos	32bits FLOAT	IR	%			0	
0X07FB	2043	1	MAIN_SRD_diffault	Diffuser Fault	1bit BOOL	DI		0	1	0	
0X07FC	2044	1	MAIN_SRD_diff_alm	SRD Rotating Stall Alarm	1bit BOOL	DI		0	1	0	
0X1042	4162	2	MAIN_SRD_lift_a	Actual Lift	32bits FLOAT	IR	°F °C			0 0	
0X1044	4164	2	MAIN_SRD_lift_1	VDO High Lift Load Line	32bits FLOAT	IR	°F °C			0 0	
0X1046	4166	2	MAIN_SRD_lift_2	VDO Low Lift Load Line	32bits FLOAT	IR	°F °C			0 0	
0X1048	4168	2	POWER_I_AMPS_A_I	Actual Line Current	32bits FLOAT	IR	amp			0	
0X104A	4170	2	POWER_I_AMPS_P_I	Percent Line Current	32bits FLOAT	IR	%			0	
0X104C	4172	2	POWER_I_VOLT_A	Actual Line Voltage	32bits FLOAT	IR	V			0	
0X104E	4174	2	POWER_I_VOLT_P	Percent Line Voltage	32bits FLOAT	IR	%			0	
0X1050	4176	2	POWER_I_KW	Line Kilowatts	32bits FLOAT	IR	kW			0	
0X1052	4178	2	POWER_I_POW_FACT	Line Power Factor	32bits FLOAT	IR				0	
0X1098	4248	2	POWER_I_In_imb_v	Line Voltage Imbalance%	32bits FLOAT	IR	%			0	
0X109A	4250	2	POWER_I_In_imb_i	Line Current Imbalance%	32bits FLOAT	IR	%			0	
0X1054	4180	2	POWER_O_MOT_FREQ	Motor Actual Frequency	32bits FLOAT	IR	Hz			0	
0X1056	4182	2	POWER_O_VFD_LOAD	VFD Load Current	32bits FLOAT	IR	amp			0	
0X1058	4184	2	POWER_O_amps_p_o	Percent VFD Load Current	32bits FLOAT	IR	%			0	
0X105A	4186	2	POWER_O_bus_volt	DC Bus Voltage	32bits FLOAT	IR	V			0	
0X105C	4188	2	POWER_O_vfd_act	Actual VFD Speed Per	32bits FLOAT	IR	%			0	
0X105E	4190	2	POWER_O_motor_pf	Motor Power Factor	32bits FLOAT	IR				0	
0X1060	4192	2	POWER_O_motor_kw	Motor Kilowatts	32bits FLOAT	IR	kW			0	
0X1062	4194	2	POWER_O_motorkwh	Motor Kilowatt-Hours	32bits FLOAT	IR	kWH			0	
0X1064	4196	2	POWER_O_enc_temp	VFD Enclosure Temp	32bits FLOAT	IR	°F °C			0 -17.777778	
0X1066	4198	2	POWER_O_inv_temp	Inverter Temperature	32bits FLOAT	IR	°F °C			0 -17.777778	
0X1068	4200	2	POWER_O_rec_temp	Rectifier Temperature	32bits FLOAT	IR	°F °C			0 -17.777778	
0X07FD	2045	1	POWER_O_VFDC_HI	High VFD Current	1bit BOOL	DI		0	1	0	
0X07FE	2046	1	POWER_O_prech_fd	Precharge Feedback	1bit BOOL	DI		0	1	0	
0X07FF	2047	1	POWER_O_lrtem_sw	LR Temp Switch	1bit BOOL	DI		0	1	0	
0X106A	4202	2	POWER_O_alm_code	VFD Alarm Code	32bits UINT	IR				0	
0X0800	2048	1	POWER_O_spd_fd	SPD Feedback	1bit BOOL	DI		0	1	0	
0X0801	2049	1	LABONLY_gv1_fc	GV1 Forced	1bit BOOL	DI		0	1	0	
0X0802	2050	1	LABONLY_gv2_fc	GV2 Forced	1bit BOOL	DI		0	1	0	
0X106C	4204	2	MAIN_MS_lead_lag	Unit is Lead or Lag	32bits UINT	IR		0	2	0	
0X0803	2051	1	MAIN_MS_ll_comm	Lead Lag Communication	1bit BOOL	DI		0	1	0	
0X106E	4206	2	MAIN_MS_ll_fault	Master Slave Fault	32bits UINT	IR		0	3	0	
0X1070	4208	2	MAIN_MS_lagstat	Slave Run Status	32bits UINT	IR		0	14	0	
0X0804	2052	1	MAIN_MS_lag_s_s	Slave Start/Stop	1bit BOOL	DI		0	1	0	
0X1072	4210	2	MAIN_MS_lagstart	Lag Start Timer	32bits FLOAT	IR	minute	0	60	0	
0X1074	4212	2	MAIN_MS_lagstop	Lag Stop Timer	32bits FLOAT	IR	minute	0	60	0	
0X1076	4214	2	MAIN_MS_prefft	Prestart Fault Timer	32bits FLOAT	IR	minute	0	30	0	
0X1078	4216	2	MAIN_MS_pulltime	Pulldown Timer	32bits FLOAT	IR	minute	0	30	0	
0X107A	4218	2	MAIN_MS_ll_hr_d	Lead/Lag Hours Delta	32bits FLOAT	IR	hour	-99999	99999	0	
0X107C	4220	2	CONF_OPT_hgbp_opt	EC/HG Valve Option	32bits UINT	IR		0	3	0	
0X107E	4222	2	CONF_OPT_hgbp_sel	EC/HG Valve Selection	32bits UINT	IR		0	3	0	
0X0805	2053	1	CONNECT_bacena	BACnet/IP Enable	1bit BOOL	DI		0	1	0	
0X0806	2054	1	CONNECT_bacunit	BACnet Metric Unit	1bit BOOL	DI		0	1	0	

APPENDIX D — CONFIGURING BMS PROTOCOL (cont)

Table D — Modbus Point Table (cont)

ADDRESS		REG. N°	PARAMETER	DESCRIPTION	DISPLAY MODE	TYPE	UNIT	VALUE			COMMENT
HEXADEC.	DEC.							MIN.	MAX.	DEFAULT	
0X1080	4224	2	CONNECT_network	BACnet Network	32bits FLOAT	IR		1	9999	1600	
0X1082	4226	2	CONNECT_bac_id	BACnet Identifier	32bits FLOAT	IR		0	9999999	1600001	
0X1088	4232	2	CONF_PRG_oil_qly	Oil Quality	32bits UINT	IR		0	2	0	
0X108A	4234	2	CONF_PRG_oil_fit	Oil Filter Failure	32bits UINT	IR		0	2	0	
0X108C	4236	2	CONF_PRG_tran_dev	Transducer Deviation	32bits UINT	IR		0	2	0	
0X108E	4238	2	CONF_PRG_ref_chg	Refrig Charge Status	32bits UINT	IR		0	2	0	
0X10A0	4256	2	POWER_I_KWH	Line Kilowatts Hours	32bits FLOAT	IR	kWH			0	
0X0BB8	3000	2	SETPOINT_ecdw_sp	Heating ECDW Setpoint	32bits FLOAT	HR	°F °C	63 17.2222248	150 65.555562	104 40.0000044	
0X0BBA	3002	2	SETPOINT_ecw_sp	Cooling ECW Setpoint	32bits FLOAT	HR	°F °C	15 -9.444444	120 48.888894	60 15.555558	
0X0BBC	3004	2	SETPOINT_ice_sp	Ice Build Setpoint	32bits FLOAT	HR	°F °C	15 -9.444444	60 15.555558	40 4.444446	
0X0BBE	3006	2	SETPOINT_lcdw_sp	Heating LCDW Setpoint	32bits FLOAT	HR	°F °C	68 20.0000028	150 65.555562	113 45.0000048	
0X0BC0	3008	2	SETPOINT_lcw_sp	Cooling LCW Setpoint	32bits FLOAT	HR	°F °C	10 -12.222222	120 48.888894	45 7.222224	
0X0BC2	3010	2	SETPOINT_dem_base	Base Demand Limit	32bits FLOAT	HR	%	10	100	100	
0X0BC4	3012	2	SETPOINT_EWT_OPT	EWT Control Option	32bits UINT	HR		0	1	0	
0X0BC6	3014	2	PROTOCOL_CHIL_S_S	Chiller Start/Stop	32bits UINT	HR		0	1	0	
0X0BC8	3016	2	PROTOCOL_CTRL_PNT	Control Point	32bits FLOAT	HR	°F °C	10 -12.222222	160 71.111118	50 10.000002	
0X0BCA	3018	2	PROTOCOL_DEM_LIM	Demand Limit	32bits FLOAT	HR	%	10	100	10	
0X0BCC	3020	2	PROTOCOL_EMSTOP	BMS Emergency Stop	32bits UINT	HR		0	1	0	
0X0BCE	3022	2	PROTOCOL_HC_SEL	Heatcool Select	32bits UINT	HR		0	1	0	
0X0BD0	3024	2	PROTOCOL_CHIL_OCC	Chiller occupied?	32bits UINT	HR		0	1	0	
0X0BD2	3026	2	GENUNIT_REM_RST	Remote Reset Alarm	32bits UINT	HR		0	1	0	
0X0BD4	3028	2	PROTOCOL_FC_START	Start Free Cooling	32bits UINT	HR		0	1	0	
0X0807	2055	1	OUTPUTS_RUN_STAT	Chiller Status(Discrete)	1bit BOOL	DI		0	1	0	

LEGEND

DI — DISCR INPUT MEDIA
 HR — HOLDING REG MEDIA
 IR — INPUT REG MEDIA