



Product Data

Aquazone™

Water Source Heat Pumps

Console Unit

3/4 to 1-1/2 Nominal Tons

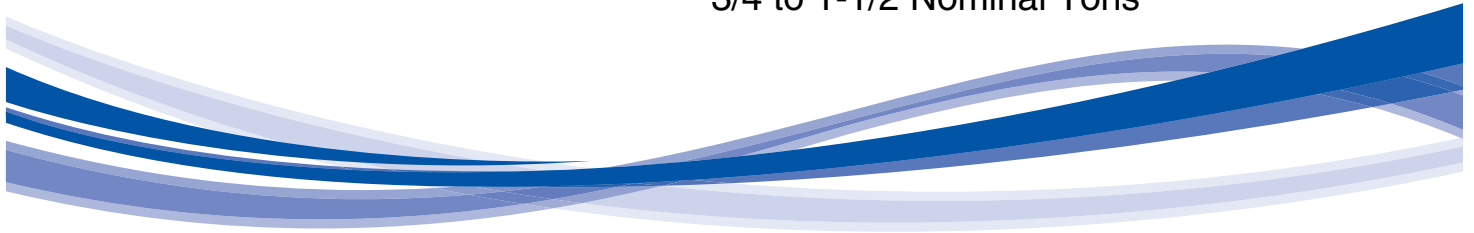

50PEC 09-18
Water Source Heat Pumps Console Unit
with Puron Advance™ Refrigerant (R-454B)

Carrier’s Aquazone console water source heat pumps are a flexible, attractive alternative for all finished interior space, under-window style installations.

The Carrier AquaZone™ 50PEC water source heat pumps utilize Puron Advance™ low GWP refrigerant (R-454B), with a GWP of 465, ensuring compliance with U.S. EPA (Environmental Protection Agency) and other regulatory agency limits of 700, and offer:

- a console unit with cost optimized design, and sloped top cabinet
- selectable cabinet and sub base size
- enhanced serviceability features, a wide variety of factory-installed options, and flexible configurations suitable for boiler tower, geothermal, and hybrid water loop systems
- optional integrated Unit mounted controller (UMC) eliminates the need for remote thermostat (not compatible with thermostat)
- optional integrated Carrier TruVu™ controls allowing for advanced equipment control and monitoring and seamless integration to the i-Vu® building automation system
- Puron Advance™ low GWP refrigerant (R-454B), with a GWP of 465, ensuring compliance with U.S. EPA (Environmental Protection Agency) and other regulatory agency limits of 700

Chassis, cabinet and sub-base construction and insulation

The unit is available as a chassis-only, chassis with sub-base, or chassis with sub-base and cabinet.

The chassis has a compact design with consistent dimensions across all model sizes, matching specified drawings. It mounts directly onto the sub-base and can be removed without disassembling the sub-base.

The sub-base is constructed of heavy gage painted steel. It can be mounted securely to the cabinet using two screws and includes cutouts for floor connections and outside air integration. It also features an integral wall bracket for added stability. The sub-base incorporates mounts for a bottom-mount, washable aluminum mesh filter for easy maintenance and airflow management.

The cabinet is constructed from heavy-gauge galvanized steel with a durable powder coat finish, providing excellent

resistance to corrosion. The unit includes removable cabinet from the sub-base, allowing full front and side access for maintenance. The cabinet is designed for either left or right-hand water piping connections. The cabinet’s slope-top design allows for efficient bottom intake and top discharge airflow, ensuring optimal operation. The standard cabinet dimensions are 12 in. deep, 48 in. wide and 24 in. tall. An optional 63 in. cabinet is also available. For flexibility, the controls can be mounted on the top right or left side. Additionally, the sloped top design discourages the use of the unit as a shelf, preventing air blockage and any spills from damaging the unit.

Both the compressor and coil compartments are thermally and acoustically insulated, featuring removable steel cover plates for double acoustic protection between compartments. The compressor access panel is lined with closed-cell foam insulation for enhanced quiet operation.

Compressor

Console Aquazone™ units include a rotary compressor on all sizes units.

Compressors are mounted on a double isolated system (i.e., from the cabinet) that maximizes vibration isolation and minimizes transmission to the unit structure.

All 50PEC compressors are mounted on a 2-piece basepan, and isolators to reduce noise and vibration transmission.

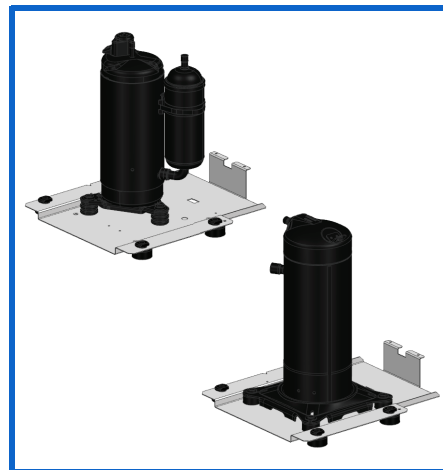

Refrigerant circuit

All units contain sealed refrigerant (R-454B) circuit including features like:

- Thermal expansion valve — Units are equipped with a thermostatic expansion valve (TXV) metering device to ensure reliable operation across a wide range of entering air and water temperatures.
- Reversing valve (4-way valve) — Units are equipped with a refrigerant reversing valve. This valve’s operation is specifically controlled to switch modes, ensuring heightened reliability in functionality.
- Pressure ports — All units are provided with high and low pressure ports integral to the refrigeration circuit for ease service.

Table of contents

	Page
Overview	2
Model Number Nomenclature	4
AHRI Capacity Ratings	5
Physical Data	5
Options and Accessories	6
Dimensions	13
Performance Data	21
Electrical Data	22
Application Data	23
Selection Procedure	31
Guide Specifications	34

Refrigerant to air heat exchanger

All units come standard with a copper tube, aluminum-fin air coil. These air coils employ lanced fin and rifled tubing for maximum heat transfer. Large face areas result in lower face velocity reducing sound while ensuring high latent heat removal for maximum dehumidification in cooling mode. For additional protection against airborne chemicals, all coils undergo an electro-coating process, ensuring long-lasting durability in various environmental conditions.

Refrigerant to water heat exchanger

50PEC units are offered with a copper coaxial (tube-in-tube) refrigerant to water heat exchanger. Optional cupronickel coaxial heat exchanger is available for higher corrosion protection. Additionally, heat exchanger is insulated to prevent condensation, and therefore potential dripping problems, in applications where the entering water temperature is less than 50°F.



Blower motor and housing

All units are equipped with a PSC motor and direct drive blower assembly for optimized performance. The motor offers two speed settings for flexibility in operation. The blower wheel is accessible through removable inlet rings, and the entire motor and blower assembly can be easily removed without detaching the chassis, simplifying maintenance and servicing.

Stainless steel drain pan with condensate switch

Protection against corrosion is a feature in the 50PEC series. A stainless steel drain pan is designed to last the lifetime of the unit and resist corrosion and cracking that may occur with steel or plastic materials.

Condensate overflow sensor

Factory-installed sensor is an electronic sensor mounted to the drain pan. When condensate pan liquid reaches an unacceptable level, the unit is automatically deactivated and placed in a lockout condition. The sensor recognizes 30 continuous seconds of overflow as a fault condition.

Unit controls

50PEC WSHPs are equipped with a 24-v low voltage control circuit. Units are selectable to be provided with no controls for control via a field installed thermostat or third party DDC or to be provided with a factory-installed Unit mounted controller, or Carrier i-Vu® TruVu™ DDC for advanced equipment control and monitoring. Regardless of the selection all units will be equipped with a unit protection module (UPM), which regulates unit operation, features integrated safeties, and simplifies unit troubleshooting.

Electrical protection

Units are offered with a standard 5 kA SCCR (Short-Circuit Current Rating). Additionally, a 40-VA, 50-VA or 75-VA transformer is included to assist in accommodating accessory loads, providing flexibility for various applications. Optional factory-installed disconnect is available for units.

Operating efficiencies

All efficiencies stated are in accordance with the latest edition of AHRI/ASHRAE/ISO 13256-1 and provide competitive high ratings cooling EERs (energy efficiency ratios) and heating COPs (coefficients of performance) in the industry. All Aquazone™ units have AHRI (Air-Conditioning, Heating, and Refrigeration Institute)/ISO, NRTL (Nationally Recognized Testing Lab), or CSA (Canadian Standards Association) labels and are factory tested under normal operating conditions at nominal water flow rates. Quality assurance is provided via testing report cards shipped with each unit to indicate specific unit performance under cooling and heating modes.

Safe, reliable operation

Equipment standard safety features include high and low refrigerant pressure protection, voltage protection, air and water coil freeze protection, condensate overflow shutdown, and optional refrigerant leak detector. All safety features are tested and run at the factory to assure proper operation of

all components and safety switches. All components are carefully designed and selected for endurance, durability, and carefree day-to-day operation. The Aquazone™ unit is shipped to provide internal and external equipment protection.

Quiet operation

The Carrier console WSHP provides quiet operation for maximum comfort. Unit is offered with 2-speed fan control (low speed is recommended minimize space noise). Additionally automatic control logic is accessible through TruVu™ DDC, enabling the unit to operate at its lowest speed when necessary.

Simple maintenance and serviceability

The Aquazone™ WSHP units are constructed to provide easy maintenance. All units allow easy access to the compressor/fan/refrigerant circuit sections from 2 sides with removable cabinet. Blower units come with permanently lubricated bearings for worry-free performance. If the unit requires service, an easily removable cabinet and slide-out fan section make access simple. Electrical disconnection of the blower motor and control box is easily accomplished via quick disconnects on each component. The refrigeration circuit is easily tested and serviced through high and low pressure ports integral to the refrigeration circuit.

Ease of installation

The unit is packaged for simple, low cost handling, with minimal time required for installation. The console unit arrives at the jobsite pre-wired and factory charged with refrigerant, and fully assembled to minimize installation time and reduce installation cost.

Water and electrical connections

Water connections are available in a variety of configurations direct from the factory. The standard configuration is 5/8 in. OD sweat connections for maximum flexibility in the field. Optional 1/2-in. female pipe threaded (FPT) water connections are available. A 5/8 in. ID vinyl condensate connection is provided for connection to the field-installed condensate line.

The standard electrical connections are made quickly and directly to a power distribution terminal block. A factory installed non-fused disconnect is available to further improve installation simplicity.

Model number nomenclature



5 0 P E C 1 2 X X A E 3 G 1 A 1

Model Series (Pos 1-5)

50PEC – AQUAZONE High Efficiency
Console Water Source Heat Pump

Nominal Capacity (Pos 6-7)

09 – 3/4 Tons
12 – 1 Tons
15 – 1-1/4 Tons
18 – 1-1/2 Tons

Water Circuit Options (Pos 8)

X – Left Hand Water Connection, 5/8" sweat connection
A – Right Hand Water Connection, 5/8" sweat connection
T – Left Hand Water Connection, 1/2" FPT Fittings
H – Right Hand Water Connection, 1/2" FPT Fittings

Cabinet and Subbase Options (Pos 9)

X – Standard 48" Cabinet and Sub-base
A – 63" Cabinet and Sub-base
T – No Cabinet and Standard Sub-base for 48" Cabinet
W – No Cabinet and No Sub-base

Control/Transformer Options (Pos 10)

A – Unit Protection Module (UPM)/40VA^a
B – Unit Protection Module (UPM)/75VA
E – UPM + TV DDC/75VA
G – UPM + Compressor Status Relay (SR), 40VA xfer^a
H – UPM + Compressor Status Relay (SR), 75VA xfer
J – UPM + Pump Relay (PR), 40VA xfer^a
K – UPM + Pump Relay (PR), 75VA xfer
L – UPM + EMS Relay (EMS), 40VA xfer^a
M – UPM + EMS Relay (EMS), 75VA xfer
U – UPM + SR + PR, 40VA xfer^a
V – UPM + SR + PR, 75VA xfer
W – UPM + EMS + SR, 40VA xfer^a
X – UPM + EMS + SR, 75VA xfer
Y – UPM + EMS + PR, 40VA xfer^a
Z – UPM + EMS + PR, 75VA xfer
1 – UPM + EMS + SR + PR, 40VA xfer^a
2 – UPM + EMS + SR + PR, 75VA xfer

Factory Installed Options (Pos 16)

1 – Cleanable Mesh Filter with Unit Mounted Controller
A – OA Damper and Cleanable Mesh Filter with Unit Mounted Controller
R – Cleanable Mesh Filter with Remote Thermostat
S – OA Damper and Cleanable Mesh Filter with Remote Thermostat

Operating Range (Pos 15)

A – Extended Range

Packaging (Pos 14)

1 – Single Pack, Domestic

Revision (Pos 13)

G – R-454B Refrigerant

Voltage (Pos 12)

3 – 208/230-1-60
4 – 265-1-60
C – 208/230-1-60 with Disconnect
D – 265-1-60 with Disconnect

Refrigerant Circuit Options (Pos 11)

E – Copper, Coated Coil (Epoxy)
J – CuNi, Coated Coil (Epoxy)

NOTE(S):

a. Standard transformer on 265-v units is 50VA.

LEGEND

CuNi — CuproNickel
EMS — EMS Relay
FPT — Female Pipe Thread
OA — Outdoor Air
PR — Pump Relay
SR — Compressor Status Relay
TV DDC — TruVu Direct Digital Controller
UMC — Unit Mounted Controller
UPM — Unit Protection Module

AHRI Capacity Ratings^{a,b,c,d}

50PEC UNIT SIZES	WATER FLOW RATE (gpm)	WATER LOOP HEAT PUMP				GROUND WATER HEAT PUMP				GROUND LOOP HEAT PUMP			
		Cooling 86°F		Heating 68°F		Cooling 59°F		Heating 50°F		Cooling 77°F		Heating 32°F	
		Capacity BTU/h	EER BTU/W-h	Capacity BTU/h	COP	Capacity BTU/h	EER BTU/W-h	Capacity BTU/h	COP	Capacity BTU/h	EER BTU/W-h	Capacity BTU/h	COP
009	2.0	8,350	14.45	9,950	5.30	8,850	16.95	6,300	3.60	9,500	22.35	8,150	4.45
012	3.0	11,350	14.50	14,150	4.90	11,800	16.65	9,100	3.50	12,650	21.05	11,750	4.20
015	4.0	13,650	14.35	16,500	4.90	14,350	16.65	10,500	3.40	15,250	19.85	13,800	4.20
018	4.5	16,950	13.00	22,450	4.55	17,550	14.50	15,000	3.45	18,450	17.55	18,700	4.00

NOTE(S):

- a. Certified in accordance with AHRI/ISO 13256-1.
- b. Cooling capacities based upon 80.6°F db, 66.2°F wb entering air temperature.
- c. Heating capacities based upon 68°F db, 59°F wb entering air temperature.
- d. For specific configuration ratings, refer to WSHP Builder in the Carrier NG eCAT.

LEGEND

- AHRI — Air-Conditioning, Heating and Refrigeration Institute
- COP — Coefficient of Performance
- db — Dry Bulb Temperature
- EER — Energy Efficiency Ratio
- GPM — Gallons per Minute
- wb — Wet Bulb Temperature



Physical data

Physical Data

50PEC UNIT SIZE	009	012	015	018
COMPRESSOR TYPE (QTY 1)	Rotary	Rotary	Rotary	Rotary
Refrigeration Charge (oz)	21.5	23	26	24.5
Max Water Working Pressure (psig/kPa)	450 / 3100	450 / 3100	450 / 3100	450 / 3100
Number of Refrigeration Circuits	1	1	1	1
EVAPORATOR COIL				
Coil Type	Tube-Fin	Tube-Fin	Tube-Fin	Tube-Fin
Air Coil Dimensions (H x L)	10 x 27	10 x 27	10 x 27	10 x 27
Row(s)	2	2	3	3
MOTOR & BLOWER				
Fan Motor Type/Speeds	PSC/2	PSC/2	PSC/2	PSC/2
Fan Motor (HP)	1/10	1/4	1/4	1/4
Blower Wheel Size (Dia. x W)	5.5 x 8 (2)	5.5 x 8 (2)	5.5 x 8 (2)	5.5 x 8 (2)
WATER CONNECTION				
Type	Sweat / FPT Option	Sweat / FPT Option	Sweat / FPT Option	Sweat / FPT Option
Size (in.)	5/8 / 1/2	5/8 / 1/2	5/8 / 1/2	5/8 / 1/2
Water Coil Type	Coaxial	Coaxial	Coaxial	Coaxial
Coaxial Coil Water Volume (gal)	0.08	0.11	0.11	0.11
Condensate Connection (in.)	5/8	5/8	5/8	5/8
CABINET				
Standard Filter - 1/2 in. Washable Aluminum (H x L)	7 x 31-1/4 x 3/8	7 x 31-1/4 x 3/8	7 x 31-1/4 x 3/8	7 x 31-1/4 x 3/8
Weight - Operating (lb)	131	138	144	144
Weight - Shipping (lb)	151	158	164	164

LEGEND

- FPT — Female Pipe Thread
- PSC — Permanent Split Capacitor

ITEM	FACTORY-INSTALLED OPTION	FIELD-INSTALLED ACCESSORY
Unit Mounted Controller	X	
Cupronickel Heat Exchangers	X	
Piping Connections	X	
Coated Air Coil	X	
Permanent Split Capacitor (PSC)	X	
Outside Air Damper	X	
Disconnect Switch	X	
TruVu™ DDC Controller	X	
User Interfaces		X
Thermostats		X
ZS Sensor		X
Supply and Return Water Hose Kits		X
Non-Communicating Sensors		X

Factory-installed options

Coated air coil

All 50PEC units come with air coil protection option as standard option. This option offers tin electro-plated copper tubing with high tech polymer coated aluminum fins will protect the air coil from all forms of corrosive elements in the airstream. Air coil protection is required for primary residence applications to protect against formicary corrosion. Protected coils exceed 1000 hours of ASTM B117 salt spray testing.

Fan motor options

Permanent Split Capacitor

Permanent split capacitor (PSC) motor is a standard option for all unit sizes. The provided motor features two-speeds that can be changed in the field.

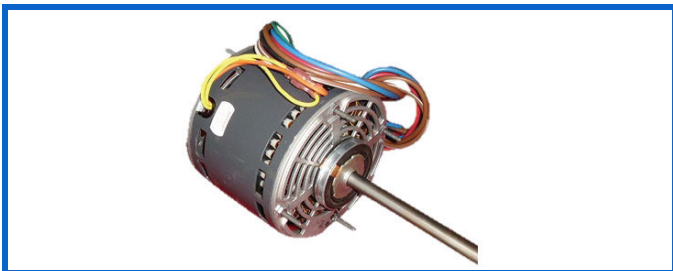

Cupronickel heat exchangers

Cupronickel heat exchangers are available for higher corrosion protection for applications such as open tower, geothermal, etc. Consult the water quality guidelines for proper application and selection of this option.

Piping connections

Piping connections can be provided on either the right or left hand side of the unit, for easy installation. Orientation is determined by facing the unit from the front side.

Hydronic field-installed options

Supply and return water hose kits

Hose kits are recommended for connection between the unit and the water loop piping. Hose kits are available in 24 or 36 inches in length. All hose kits come with flexible stainless steel hoses and have options for manual isolation valves with and without autoflow regulators and Y-strainer.

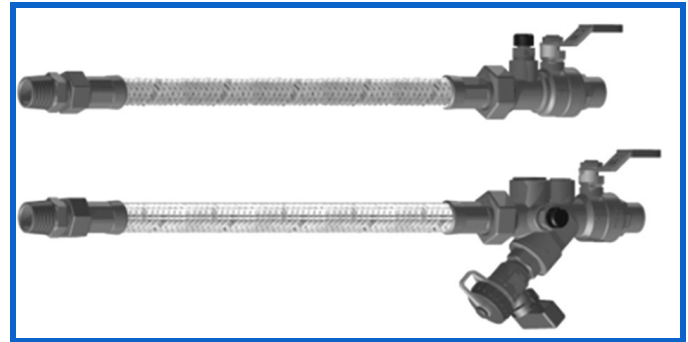

Autoflow regulator

Field-installed pressure independent Autoflow Regulator (automatic balancing valve) is a part of the hose kit and is available with wide range of set flow rate internal cartridges. Factory-installed auto-flow regulator ensures a constant water flow rate to the unit. The system installation is much easier with autoflow regulators compared to manually balanced systems, and the “fluctuation” seen in manually balanced systems is no longer an issue.

Ball valves

Carrier’s ball valves can be field installed between supply and return lines and the WSHP. These valves provide manual stoppage of water flow during maintenance or when service is needed.

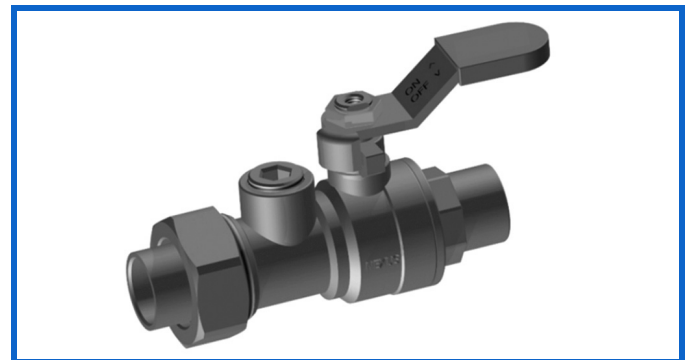

Two-position motorized isolation valve (2-way solenoid valve)

Carrier's motorized water valves are normally closed, 2-position water valves field installed on the WSHP return line. The valve opens to allow 100% of the fluid flow through the WSHP when compressor energized and closes to shut off flow to the WSHP when compressor is deenergized. Closing off fluid flow to the unit when there is no call for cooling or heating reduces system operating costs, when using variable speed pump.

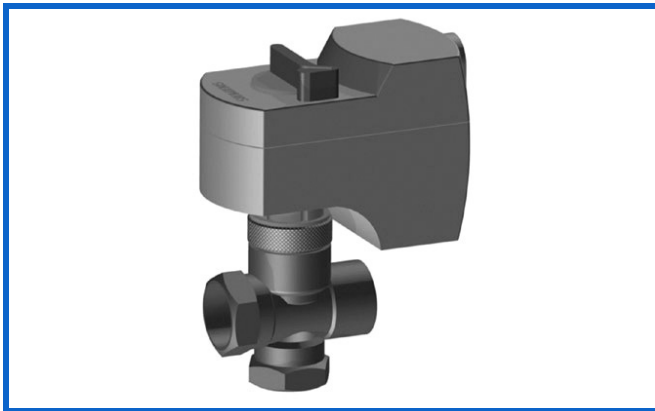

Y-Strainers

Carrier's strainers are field installed on the supply line of the WSHP. These strainers are a combination strainer and ball valve and equipped with a union end, blow down port, and two accessory ports. The strainers provide a 20-mesh removable filter screen.

Controls options

Unit Protection Module (UPM)

All Carrier WSHP units feature an advanced UPM which implements all the critical equipment safeties and allows for continuous safe and reliable operation. It's located in the control box.

Features of the unit protection module include:

- High and Low Refrigerant Pressure Protection: The unit is equipped with high and low-pressure switches set to disable operation at pressures above 600 psig or below 40 psig.
- Low Pressure Bypass Timer: This bypass helps to eliminate nuisance trips by keeping the compressor on for 120s upon the LPS opening. If the LPS is still open after 2 minutes the unit is shut down and put into soft lockout.
- Air and Water Coil Freeze Protection: Both the cooling and heating refrigerant liquid line temperatures are monitored to prevent freeze up of both the water and air coil. The freeze limit by default is set to 25°F and is configurable via a dip switch on the UPM to 15°F for applications utilizing antifreeze.
- High Condensate Level Shutdown: All units are equipped with a condensate overflow sensor in the drain pan set to disable operation in the event of an overflow condition.
- Anti-Short Cycle Time Delay: A 5-minute delay on break timer to prevent compressor short cycling.
- Random Start Time Delay: Each controller has a unique random start delay ranging from 270 to 300 seconds on initial power up to reduce the chance of multiple units simultaneously starting at the same time after powering up or after a power interruption, thus avoiding creating large inrush current.
- Brownout/Surge Protection: The UPM board will disable the compressor if the incoming low voltage power falls below 18 vac.

- Intelligent Alarm Reset: Upon fault, a 5-minute break is initiated, and the unit will automatically restart after this time period has expired.
- Hard Lockout Reset: A hard lockout can be reset by turning the unit thermostat off and then back on when the RESET DIP switch is set to "Y" or by shutting off unit power at the circuit breaker when the RESET DIP switch is set to "R".
- Alarm Output: The alarm output is normally open (NO) dry contact. The output is configurable via a dip switch on the UPM to be constant, as a general alarm, or pulsed, to be interpreted for the specific alarm by a remote device.
- Test Mode: The UPM features a test mode for ease of service which shortens the anti-short cycle and random start delays and requires manual reset for both soft and hard lockouts.

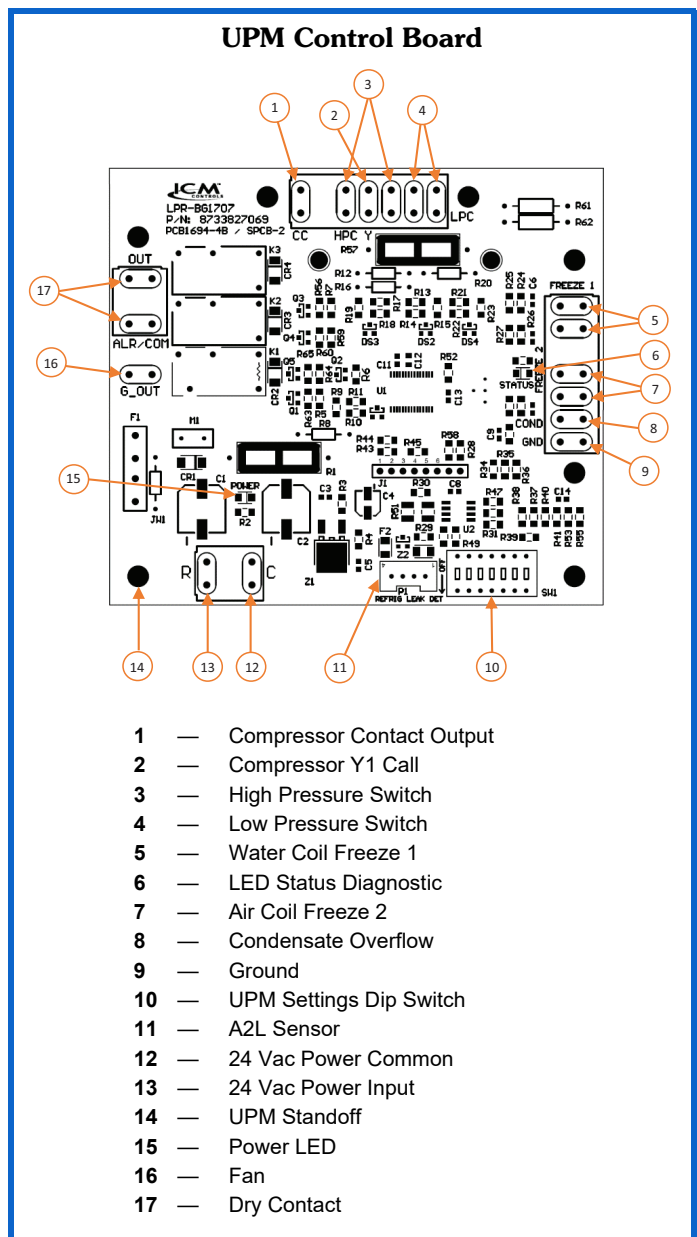

Unit mounted controller

The unit mounted controller is a factory-wired option that eliminates the need for a remote mounted thermostat. The standard unit mounted controller provides a tactile touch-pad for temperature, fan and mode adjustment as shown. Temperature is read in a digital display, with an LED display indicating unit operating mode, as well as fan speed. Temperature set points are adjustable from 60°F to 80°F, with an adjustable temperature differential between 1°F and 6°F. Selectable options include manual or automatic changeover, high or low fan speed as well as constant fan operation or fan operation to cycle with the compressor.

NOTE: The unit mounted controller (UMC) is not compatible with thermostat or DDC controls.









Thermostat control

The Carrier 50PEC series water source heat pumps utilizes 24-v non-communicating controls and are suitable for control via most 24-v non-communicating single stage heat pump thermostats. Carrier has several 24-v non communicating thermostats that are well suited for pairing with water source heat pumps. See “Thermostats” table for a summary of the available carrier thermostats and the general functionality/capability of each.

Options and accessories (cont)



Thermostats

								
TYPE	NON-COMMUNICATING THERMOSTATS		BACNET [®] a THERMOSTAT WITH WI-FI				BACNET THERMOSTAT	
Feature	Comfort Pro Programmable Thermostat	Edge Pro Programmable Thermostat	Connect 43FX Thermostat	Connect BACnet Wi-Fi Thermostat	Non-Branded 43FX Thermostat	Non-Branded BACnet Wi-Fi Thermostat	ComfortVu BACnet Standard Thermostat	ComforVu BACnet Plus Thermostat
	33CSCPACHP-01	33CS2PP2S-03/ 33CS2PPRH-03	33CONNECTSTAT43FX	33CONNECTSTAT43	33WIFISTAT43FX	33WIFISTAT43	TB-24-C/ TB24-HM-C	TBPL-24-H-C
Power	24 Vac	24 Vac	24 Vac	24 Vac	24 Vac	24 Vac	24 Vac	24 Vac
Power Requirements	3 Va	3 Va	6 Va	6 Va	6 Va	6 Va	4 Va Unit, 76 Va Full Load	4 Va Unit, 76 Va Full Load
Interface	Backlit Display	Backlit Display	4.3" LCD Touchscreen	4.3" LCD Color Touchscreen	4.3" LCD Touchscreen	4.3" LCD Color Touchscreen	LCD Push Button	LCD Touchscreen
Onboard Sensors	Temperature	Temperature & Humidity (optional)	Temperature & Humidity	Temperature & Humidity	Temperature & Humidity	Temperature & Humidity	Temperature & Humidity	Temperature & Humidity
Scheduling	√	√	√	√	√	√	√	√
Occupancy (motion)	—	—	—	—	—	—	4	4
Compressor Stages	1-2	1-2	1-3	1-3	1-3	1-3	1-2	1-2
Auxiliary Heat Stages	1	1	1-2	1-2	1-2	1-2	1-3	1-3
Fan Control	1-Speed	1-Speed	1-Speed	1-Speed	1-Speed	1-Speed	1 to 3-Speed	1 to 3-Speed
Dehumidification Output for HGRH	—	√	√	√	√	√	—	√
Humidification Output	—	√	√	√	√	√	4	√
Remote Sensors	OAT / RSS / SAT / RAT	OAT / RSS	RH + OAT / RSS / SAT	OAT / RSS / SAT	RH + OAT / RSS / SAT	OAT / RSS / SAT	ECON / RSS / DEICE	ECON / RSS / DEICE
Dry Contact	—	Dehum or Economizer	OCC / ECFL / FLTR	OCC / ECFL	OCC / ECFL / FLTR	OCC / ECFL	Window / Door / Keytag	Window / Door / Keytag
BACnet MS/TP	—	—	√	√	√	√	√	√
Wi-Fi	—	—	√	√	√	√	—	—
Accessories	OAT Sensor: 33ZCSENOAT Remote Temperature with Averaging: 33ZCT55SPT Remote Supply/Return Temp Sensing: 33ZCSENSAT							

NOTE(S):

- a. Third-party trademarks and logos are the property of their respective owners.

Control options to supplement thermostat

50PEC units have a number of control options available to supplement the control of a thermostat allowing for control of various auxiliary components that thermostats are not typically capable of controlling. These options include:

Energy management switch (EMS) relay

An optional relay providing a normally open set of contacts for remotely enabling and disabling the unit via an external 24 vac signal.

Pump relay

An optional relay providing a signal to energize a pump when the compressor is command to run.

Compressor status relay

Optional relay providing compressor status via a normally open set of dry contacts.

Carrier i-Vu® WSHP TruVu™ DDC

Carrier's WSHP TruVu™ controller is an integrated component of a Carrier water source heat pump. The WSHP TruVu™ controller continuously monitors and regulates water source heat pump operation with reliability and precision. This advanced controller features a sophisticated, factory-engineered control program that provides optimum performance and energy efficiency. It also features plug and play connectivity to the Carrier i-Vu® Building Automation System. For added flexibility, the controller is capable of stand-alone operation, or it can be integrated with any other building automation system utilizing BACnet IP.

Application Features

- Provides space temperature control with up to 2 stages of mechanical cooling and heating.
- Controls modulating or 2-position outside air damper to meet ASHRAE 62 ventilation requirements.
- Automatic 2-speed fan control for efficient WSHP operation. Using the space temperature input, the TruVu™ controller automatically operate the fan at the optimal speed to maintain space temperature while providing increased latent heat removal, reduced sound and the lowest fan energy consumption.
- Equipment Performance Monitoring/Statuses — Compressor Status, Fan Status, Water flow switch, Secondary Condensate Overflow, EWT, LWT, SAT, RAT.
- Scheduling — Adaptable scheduling for occupied and unoccupied periods with ability for internal/local occupancy configuration or remote occupancy configuration via external dry contact, local user interfaces, i-Vu® network, or BAS network. Additionally, flexible intermittent fan operation is available during both occupied and unoccupied periods for energy savings.

- Learning adaptive optimal start. Transitions the WSHP from unoccupied set points to occupied set points in the most efficient means possible. Over time, the WSHP will learn and determine the best adjustment rates of the set points to provide the most efficient means of shifting the WSHP to an occupied mode.
- Space temperature input via communicating ZS sensor, or non-communication zone sensor (10K thermistor), or over the network.
- Shutdown Inputs — Fire/Smoke Detector Shutdown and Network Shutdown to safely shutdown the unit in a controlled fashion with ability to monitor the unit.
- Alarm Status — Alarms status is accessible through equipment user interfaces or network. (see TruVu™ Alarms Table).

Hardware Features

- USB port for service/commissioning/troubleshooting, hard-wired via laptop/smartphone/TruVu™ ET Display, or wireless service connections via USB-WiFi kit
- dual 10/100 Mbps, BACnet IP and IP addressing
- supports home run, daisy chain and ring IP network topologies
- capacitor-backed real-time clock keeps time in the event of power failure or network interruption for at least three days
- LED indicators for power, status of network and controller, and 1 programmable LED indicator
- supports Rnet devices like ZS sensors, Equipment touch, and TruVu™ ET Display
- supports Act Net devices (Smart actuators)

System Features

- integrated Carrier waterside linkage algorithm for plug-and-play integration with the Carrier WSHP System
- fully plug-and-play with the Carrier i-Vu® Building Automation System
- supports demand limiting for maximum energy savings
- compatible with i-Vu® Tenant Billing for tracking tenant's after-hours energy usage
- built-in network diagnostic capture functionality for troubleshooting
- network statistics that can be viewed numerically or as trend graphs

TruVu™ Alarms

ALARM	DESCRIPTION
Fire/Smoke Detector Alarm	Immediate shutdown of equipment (fan, compressor, aux heat, and damper) after alarm is generated.
Space Temperature Alarms	Generates an alarm whenever the space temperature exceeds configurable alarm set points for occupied and unoccupied periods.
Source Water Temperature Alarm	Four configurable alarm limits for leaving condenser water temperature.
Supply Air Temperature Alarm	Two configurable alarm limits for supply air temperature.
High Condensate/Overflow Alarm	Disables the compressor and fan outputs when alarm is generated.
Fan Status Alarm	Monitors the fan output and alarm is generated after 30 seconds and no fan status (all speeds).
Compressor Status Alarm	Monitors the compressor output and alarm is generated after 6 minutes of energizing compressor and no status.
Filter Status Alarm	Generates an alarm after the number of fan run hours exceeds a configurable filter alarm timer limit.
Indoor Air Quality Alarm	Generates an alarm during occupied periods whenever the CO ₂ sensor value exceeds the user adjustable limit.
Relative Humidity Alarm	Generates an alarm whenever the space relative humidity exceeds configurable alarm set point.
Source Water Linkage Failure Alarm	Generates an alarm after linkage fail with Water loop controller for > 6 min.
Airside Linkage Failure Alarm	Generates an alarm once linkage fails for > 6 min.

TruVu™ Alarms (cont)

ALARM	DESCRIPTION
OAT Sensor Alarm	Generates an alarm if the value of OAT fails to be updated through the network.
SPT (space temperature) Sensor Alarm	Generates an alarm if the SPT sensor fails to communicate with the control for > 5 minutes.
ZS Sensor Alarm	Generates an alarm if the ZS sensor fail to communicate with the control for > 5 minutes.
Return Air Temperature Alarm	Configurable alarm limits for return air temperature.
Entering Water Temperature Alarm	Configurable alarm limits for entering condenser water temperature.
Water Side Delta T Alarm	Configurable alarm limits for waterside Delta T.
Air Side Delta T Alarm	Configurable alarm limits for airside Delta T.
Low Water Flow Alarm	Monitors the differential pressure switch, generates alarm if unit has no flow.
UPM Alarm - Hard Lockout Status	Generates alarm if hard lockout conditions occurred on UPM board. Soft lockout alarm history can be viewed.
Source Water Valve Alarm	Monitors communicating source water valve (ACT net), alarm is generated if valve fails to communicate.

Field-installed TruVu™ DDC accessories

ZS Sensors

ZS sensors are the preferred method of monitoring space temperature, humidity and CO₂ levels when using the TruVu™ controller.

TruVu™ DDC Accessories

	ZS Standard	ZS Plus	ZS Pro	ZS Pro-M	ZS Pro-F
Model Number	ZS-CAR	ZSPL-CAR	ZSP-CAR	ZS P-M-CAR	ZSPF-CAR
Temp CO ₂ Humidity Options	X	X	X	X	X
VOC Options	X	X	X	X	X
Neutral Color	X	X	X	X	X
Motion-Sensing Option				X	
Addressable / Supports Daisy-Chain	X	X	X	X	X
Hidden Communication Port	X	X	X	X	X
Mounts on a Standard 2 x 4 in. Electrical Box	X	X	X	X	X
Occupancy Status Indicator		X	X	X	X
Push Button Occupancy Override		X	X	X	X
Setpoint Adjust		X	X	X	X
Large Easy-to-Read LCD			X	X	X
Alarm Indicator			X	X	X
Fan Speed Control					X
Cooling / Heating/ Fan Only - Mode Control					X
°F to °C Conversion Button					X

User interfaces

Interfaces are used for start up, commissioning, access information, read sensor values, set or adjust setpoints and schedules, view trends, and monitor alarms.

TruVu™ ET Display

Carrier's TruVu™ equipment touch (ET) displays are an integrated component of the i-Vu® building automation system. They feature illuminated color pixel touchscreens in two different sizes and connect to a single i-Vu® controller. Designed for panel or wall mounting, they provide building occupants, facility managers, and technicians a powerful user interface for managing HVAC equipment in a building. It can view or change its property values, schedule equipment, view trends and alarms, and more, without having to access the system's server. For more details about the TruVu™ equipment touch devices, see either the TruVu™ ET Display Installation and Setup Guide.



Field Assistant

Field assistant is a standalone tool you can install on computer or laptop to access a single TruVu™ controller, several controllers, or a network of i-Vu® TruVu™ controllers (up to 750 controllers). It can communicate with the devices using USB port on the TruVu™ controller or over an IP network. For more details about the Field Assistant tool, see Field assistant tool Help manual.

Field provided non-communicating sensors

In addition to supplement thermostat or DDC controller, a variety of non-communicating sensors are available to fulfill specific requirements of your application.

Non-Communicating Sensors

PART NUMBER	DESCRIPTION
33ZCSENSRH-02	Space Wall Mounted Relative Humidity Sensor
33ZCSPTCO2-01	CO ₂ / Space Temp. Sensor without LCD Display and No Override
33ZCT55CO2-02	Space Temp and CO ₂ Room Sensor with Override
33ZCSPTCO2LCD-01	CO ₂ / Space Temp. Sensor with LCD Display and No Override
33ZCT55CO2-02	Space Temp. and CO ₂ Room Sensor with Override
33ZCT56CO2-02	Space Temp. and CO ₂ Room Sensor with Override and Set Point Adjustment
33ZCT55SPT	Space Temperature Sensor with Override
33ZCT56SPT	Space Temperature Sensor with Override and Set Point Adjustment
33ZCT59SPT	Space Temperature Sensor with Override and Set Point Adjustment and Digital Display

50PEC09-18 Unit Dimensions — Standard 48 in. Cabinet and Sub-base (Left Hand)

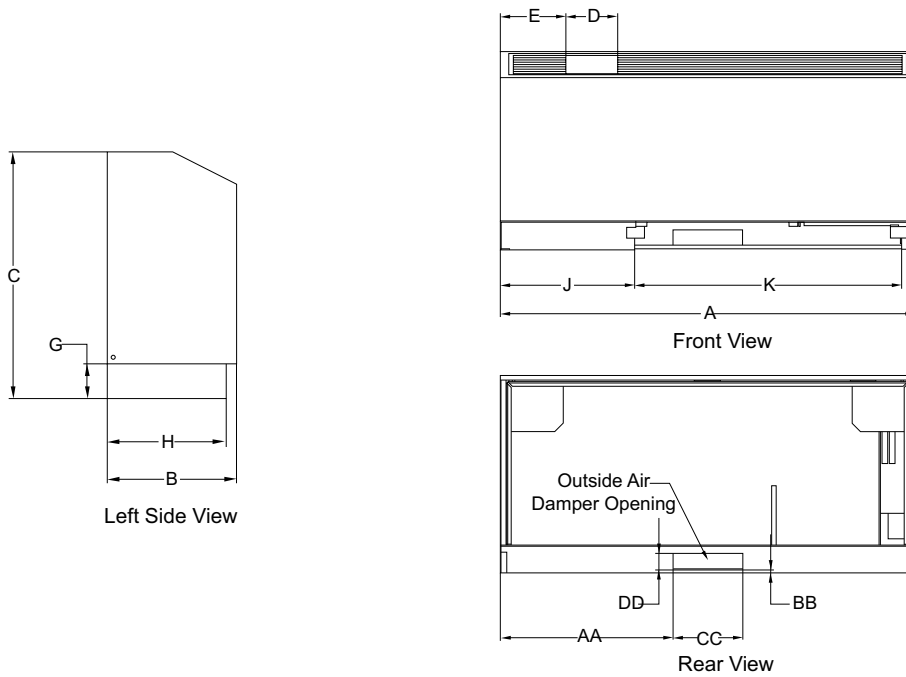

UNIT SIZE ^{a,b}	WATER CONNECTIONS	CABINET LENGTH	A	B	C	D	E	G	H	J	K
			Width	Depth	Height	Control Door Width	Cabinet End to Door	Clearance to Unit Bottom	Sub-Base Depth	Cabinet End to Return Air	Return Air Width
50PEC 009-018	LH	Std	48.00	12.00	24.00	6.00	7.13	3.50	11.00	15.50	30.75

UNIT SIZE	AA	BB	CC	DD	CONDENSER WATER CONNECTIONS (in.)	PERMANENT WASHABLE FILTER SIZE (in.)
	Cabinet End to Outside Air Damper Opening	Bottom to Outside Air Damper Opening	Outside Air Damper Opening Height	Outside Air Damper Opening Height		
50PEC 009-018	20.00	0.38	8.00	2.00	5/8 tube	30.25 x 7 x 0.375

NOTE(S):

- a. All dimensions in inches unless otherwise noted. All dimensions within ± 0.125 inch. Specifications subject to change without notice.
- b. Fresh air opening (in sub-base rear):
When installing unit in cold climates, an outside air damper must be provided to prevent possible condenser freeze-up.

50PEC09-18 Unit Dimensions — Standard 48 in. Cabinet and Sub-base (Right Hand)

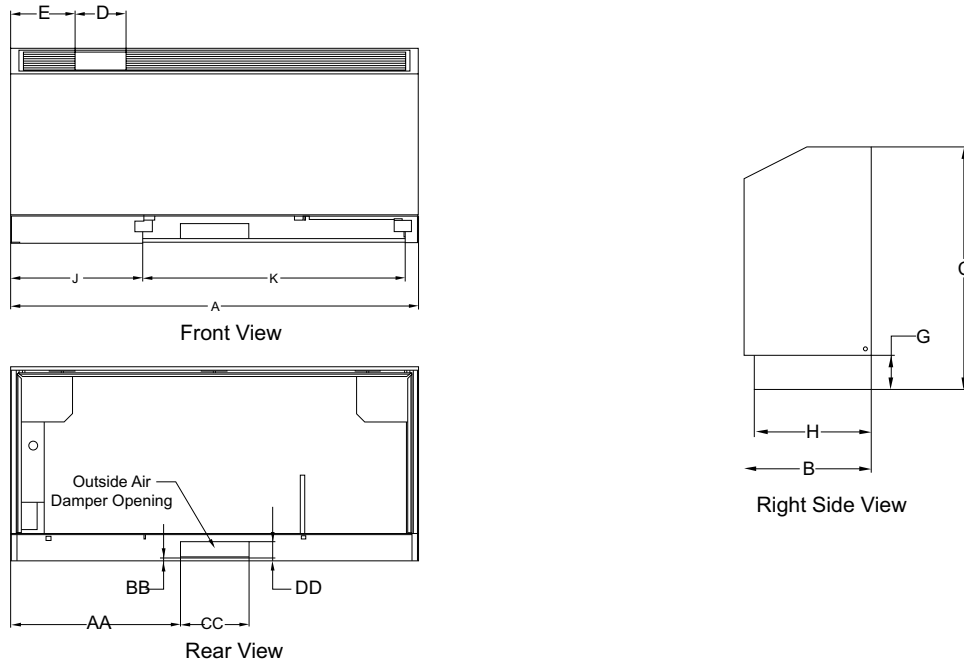

UNIT SIZE ^{a,b}	WATER CONNECTIONS	CABINET LENGTH	A	B	C	D	E	G	H	J	K
			Width	Depth	Height	Control Door Width	Cabinet End to Door	Clearance to Unit Bottom	Sub-Base Depth	Cabinet End to Return Air	Return Air Width
50PEC 009-018	RH	Std	48.00	12.00	24.00	6.00	3.88	3.50	11.00	13.25	30.75

UNIT SIZE	AA	BB	CC	DD	CONDENSER WATER CONNECTIONS (in.)	PERMANENT WASHABLE FILTER SIZE (in.)
	Cabinet End to Outside Air Damper Opening	Bottom to Outside Air Damper Opening	Outside Air Damper Opening Height	Outside Air Damper Opening Height		
50PEC 009-018	20.00	0.38	8.00	2.00	5/8 Tube	30.25 x 7 x 0.375

NOTE(S):

- a. All dimensions in inches unless otherwise noted. All dimensions within ± 0.125 inch. Specifications subject to change without notice.
- b. Fresh air opening (in sub-base rear):
When installing unit in cold climates, an outside air damper must be provided to prevent possible condenser freeze-up.

50PEC09-18 Unit Dimensions — Extended 63 in. Cabinet and Sub-base (Left Hand)

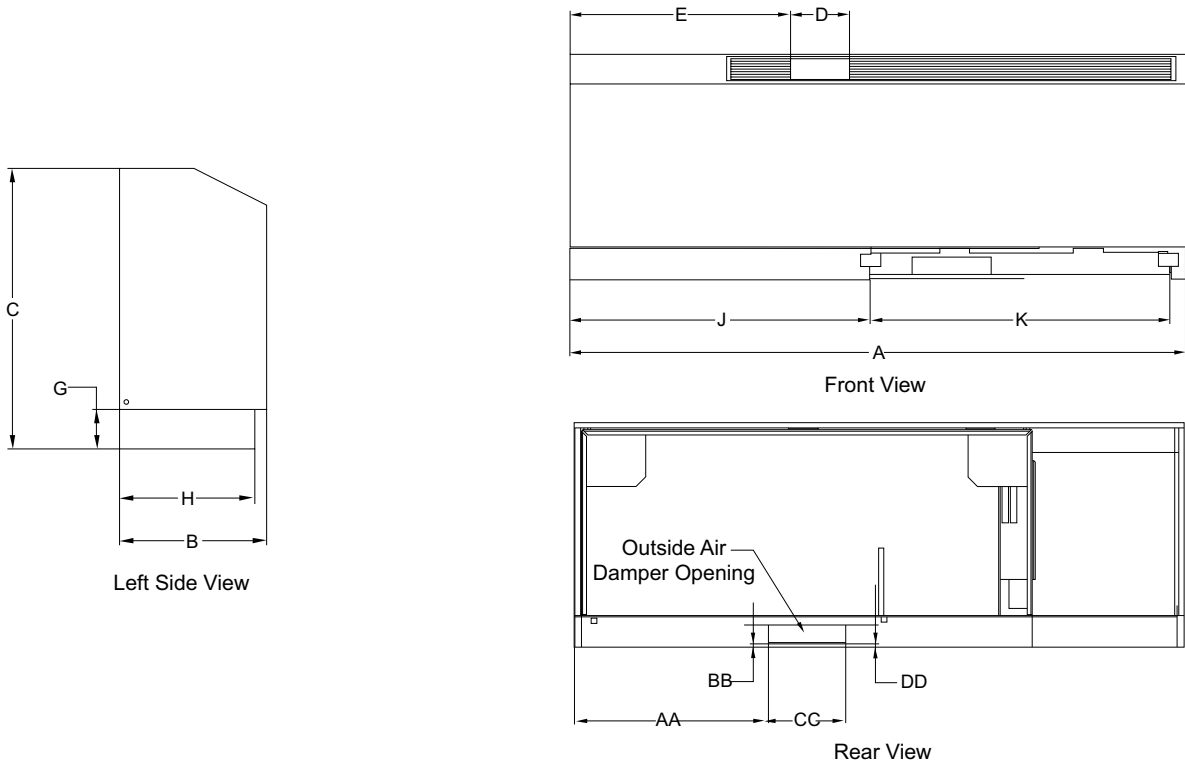

UNIT SIZE ^{a,b}	WATER CONNECTIONS	CABINET LENGTH	A	B	C	D	E	G	H	J	K
			Width	Depth	Height	Control Door Width	Cabinet End to Door	Clearance to Unit Bottom	Sub-Base Depth	Cabinet End to Return Air	Return Air Width
50PEC 009-018	LH	Ext	63.00	12.00	24.00	6.00	22.12	3.50	11.00	30.75	30.75

UNIT SIZE	AA	BB	CC	DD	CONDENSER WATER CONNECTIONS (in.)	PERMANENT WASHABLE FILTER SIZE (in.)
	Cabinet End to Outside Air Damper Opening	Bottom to Outside Air Damper Opening	Outside Air Damper Opening Height	Outside Air Damper Opening Height		
50PEC 009-018	20.00	0.38	8.00	2.00	5/8 tube	30.25 x 7 x 0.375

NOTE(S):

- a. All dimensions in inches unless otherwise noted. All dimensions within ± 0.125 inch. Specifications subject to change without notice.
- b. Fresh air opening (in sub-base rear):
When installing unit in cold climates, an outside air damper must be provided to prevent possible condenser freeze-up.

Dimensions (cont)



50PEC09-18 Unit Dimensions — Extended 63 in. Cabinet and Sub-base (Right Hand)

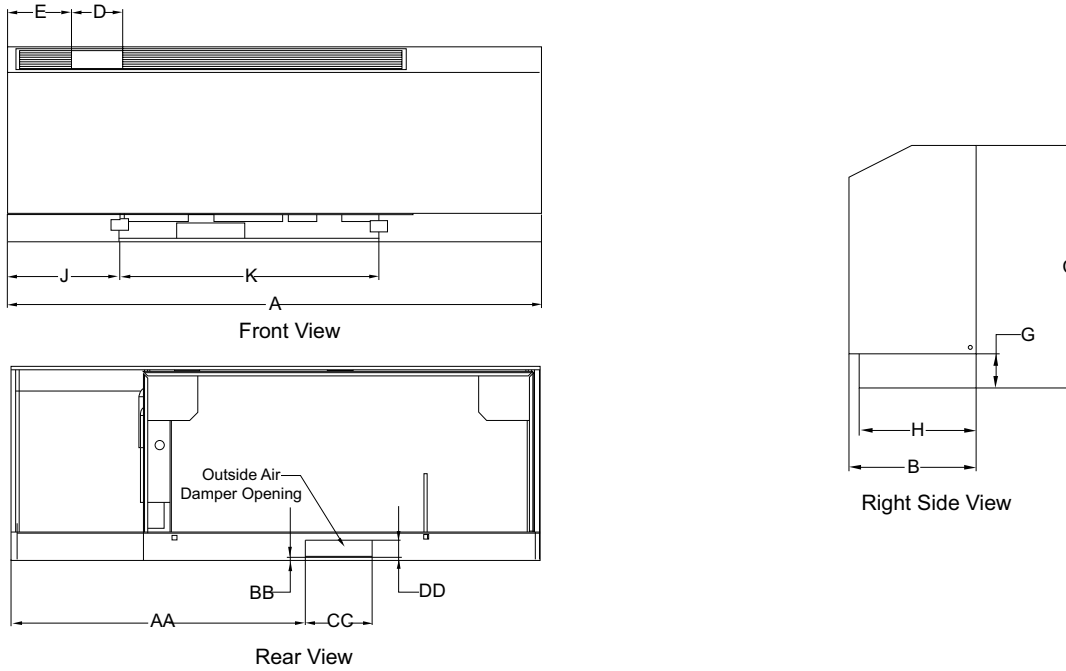

UNIT SIZE ^{a,b}	WATER CONNECTIONS	CABINET LENGTH	A	B	C	D	E	G	H	J	K
			Width	Depth	Height	Control Door Width	Cabinet End to Door	Clearance to Unit Bottom	Sub-Base Depth	Cabinet End to Return Air	Return Air Width
50PEC 009-018	RH	Ext	63.00	12.00	24.00	6.00	3.88	3.50	11.00	13.25	30.75

UNIT SIZE	AA	BB	CC	DD	CONDENSER WATER CONNECTIONS	PERMANENT WASHABLE FILTER SIZE
	Cabinet End to Outside Air Damper Opening	Bottom to Outside Air Damper Opening	Outside Air Damper Opening Height	Outside Air Damper Opening Height		
50PEC 009-018	35.00	0.38	8.00	2.00	5/8 in. tube	30.25 x 7 x 0.375

NOTE(S):

- a. All dimensions in inches unless otherwise noted. All dimensions within ± 0.125 inch. Specifications subject to change without notice.
- b. Fresh air opening (in sub-base rear):
When installing unit in cold climates, an outside air damper must be provided to prevent possible condenser freeze-up.

50PEC09-18 Unit Dimensions — No Cabinet and Standard Sub-base for 48 in. Cabinet (Left Hand)

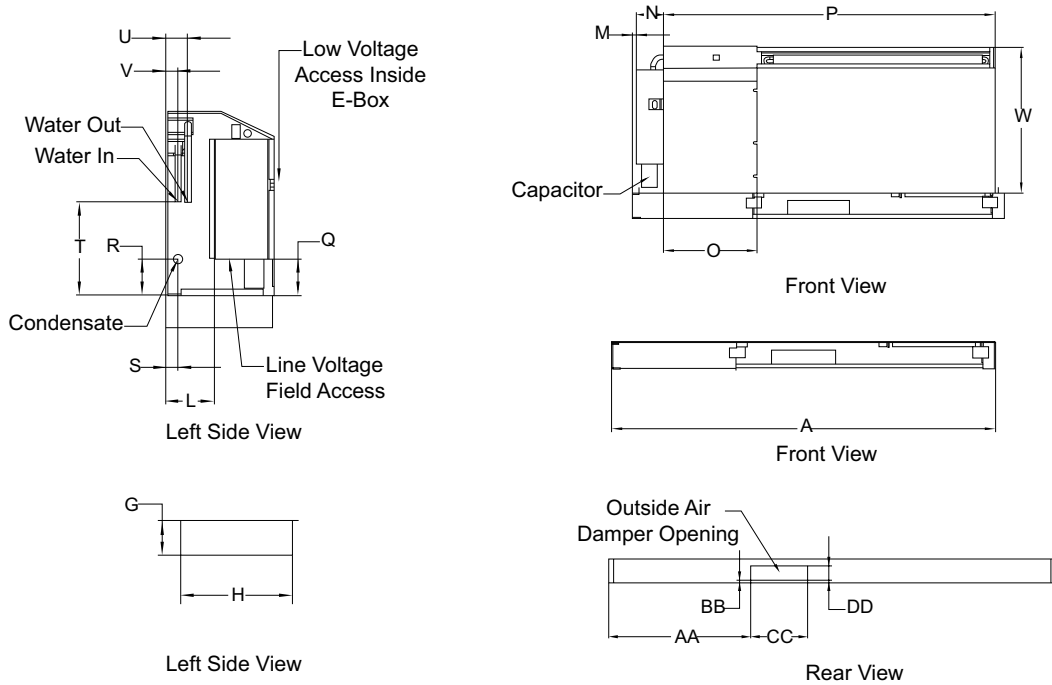

UNIT SIZE ^{a,b}	WATER CONNECTIONS	CABINET LENGTH	A	G	H	L	M	N	O	P	Q
			Width	Clearance to Unit Bottom	Sub-base Depth	Electrical Box to Back of Chassis	Sub-base End to Electrical Box	Electrical Box Width	Control Panel Width	Chassis Width	Electrical Box Height from Sub-base
50PEC 009-018	LH	Std	48.00	3.50	11.00	5.00	0.50	3.50	12.00	42.88	3.87

UNIT SIZE	R	S	T	U	V	W	AA	BB	CC	DD
	Condensate Height From Sub-base	Condensate Depth from Rear	Water Connection Height from Sub-base	Water Out Depth from Sub-base Rear	Water In Depth from Sub-base Rear	Chassis Height	Cabinet End to Outside Air Damper Opening	Bottom to Outside Air Damper Opening	Outside Air Damper Opening Width	Outside Air Damper Opening Height
50PEC 009-018	3.75	1.25	10.00	2.25	1.25	19.75	20.00	0.38	8.00	2.00

UNIT SIZE	CONDENSER WATER CONNECTIONS (in.)	PERMANENT WASHABLE FILTER SIZE (in.)
50PEC 009-018	5/8 tube	30.25 x 7 x 0.375

NOTE(S):

- All dimensions in inches unless otherwise noted. All dimensions within ± 0.125 inch. Specifications subject to change without notice.
- Fresh air opening (in sub-base rear):
When installing unit in cold climates, an outside air damper must be provided to prevent possible condenser freeze-up.

50PEC09-18 Unit Dimensions — No Cabinet and Standard Sub-base for 48 in. Cabinet (Right Hand)

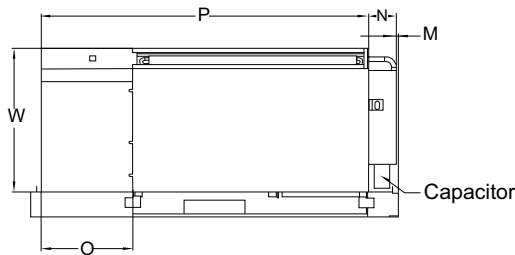

Front View



Front View

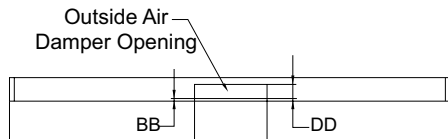

Rear View

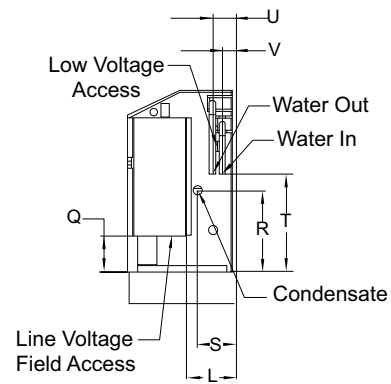

Right Side View

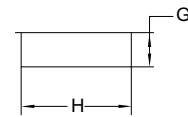

Right Side View

UNIT SIZE ^{a,b}	WATER CONNECTIONS	CABINET LENGTH	A	G	H	L	M	N	O	P	Q
			Width	Clearance to Unit Bottom	Sub-Base Depth	Electrical Box to Back of Chassis	Sub-base End to Electrical Box	Electrical Box Width	Control Panel Width	Chassis Width	Electrical Box Height from Sub-base
50PEC 009-018	RH	Std	48.00	3.50	11.00	5.00	0.38	3.50	12.00	42.88	3.87

UNIT SIZE	R	S	T	U	V	W	AA	BB	CC	DD
	Condensate Height from Sub-base	Condensate Depth from Rear	Water Connection Height from Sub-base	Water Out Depth from Sub-base Rear	Water In Depth from Sub-base Rear	Chassis Height	Cabinet End to Outside Air Damper Opening	Bottom to Outside Air Damper Opening	Outside Air Damper Opening Width	Outside Air Damper Opening Height
50PEC 009-018	8.75	4.00	10.00	2.25	1.25	19.75	20.00	0.38	8.00	2.00

UNIT SIZE	CONDENSER WATER CONNECTIONS (in.)	PERMANENT WASHABLE FILTER SIZE (in.)
50PEC 009-018	5/8 Tube	30.25 x 7 x 0.375

NOTE(S):

- a. All dimensions in inches unless otherwise noted. All dimensions within ± 0.125 inch. Specifications subject to change without notice.
- b. Fresh air opening (in sub-base rear):
When installing unit in cold climates, an outside air damper must be provided to prevent possible condenser freeze-up.

50PEC09-18 Unit Dimensions — No Cabinet and No Sub-base (Left Hand)

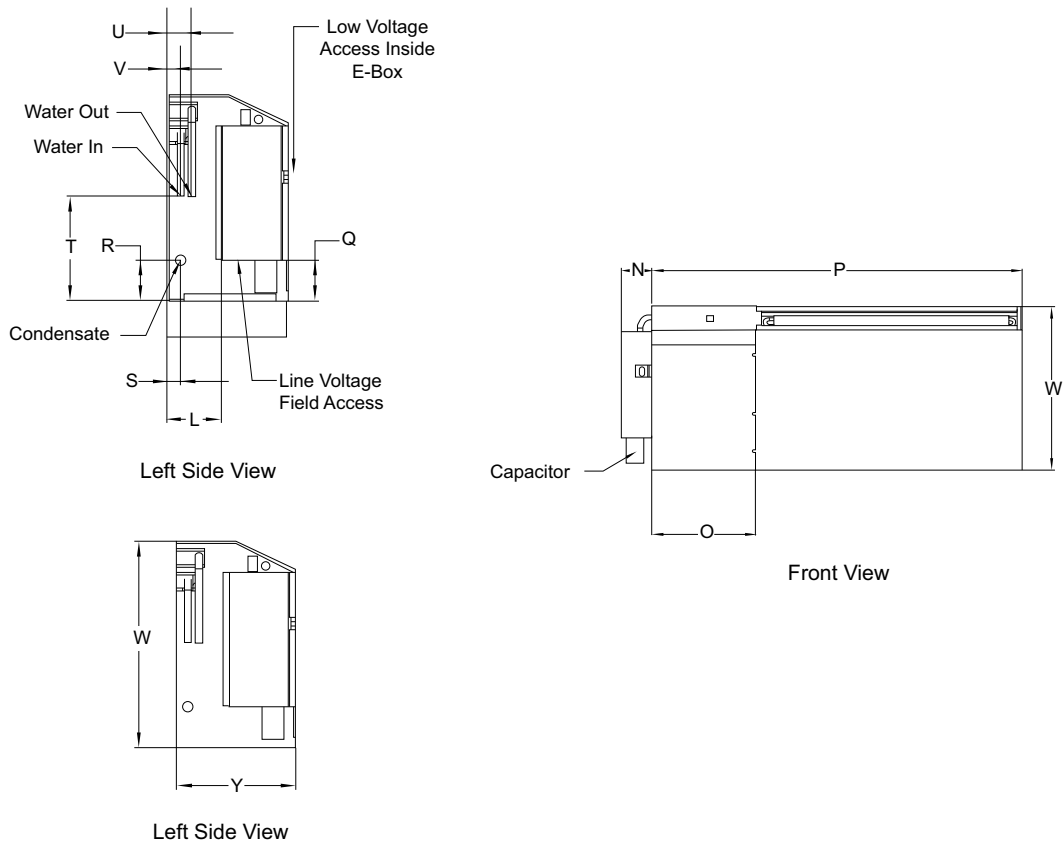

UNIT SIZE ^{a,b}	WATER CONNECTIONS	CABINET LENGTH	L	N	O	P	Q	R	S	T	U
			Width	Depth	Height	Control Door Width	Cabinet End to Door	Clearance to Unit Bottom	Sub-Base Depth	Cabinet End to Return Air	Return Air Width
50PEC 009-018	LH	—	5.00	3.50	12.00	42.88	3.87	3.75	1.25	10.00	2.25

UNIT SIZE	V	W	Y	CONDENSER WATER CONNECTIONS (in.)	PERMANENT WASHABLE FILTER SIZE (in.)
	Water In Depth from Sub-base Rear	Chassis Height	Chassis Depth		
50PEC 009-018	1.25	19.75	11.00	5/8 tube	—

NOTE(S):

- a. All dimensions in inches unless otherwise noted. All dimensions within ± 0.125 inch. Specifications subject to change without notice.
- b. When installing unit in cold climates, an outside air damper must be provided to prevent possible condenser freeze-up. Sub-base is not included.

50PEC09-18 Unit Dimensions — No Cabinet and No Sub-base (Right Hand)

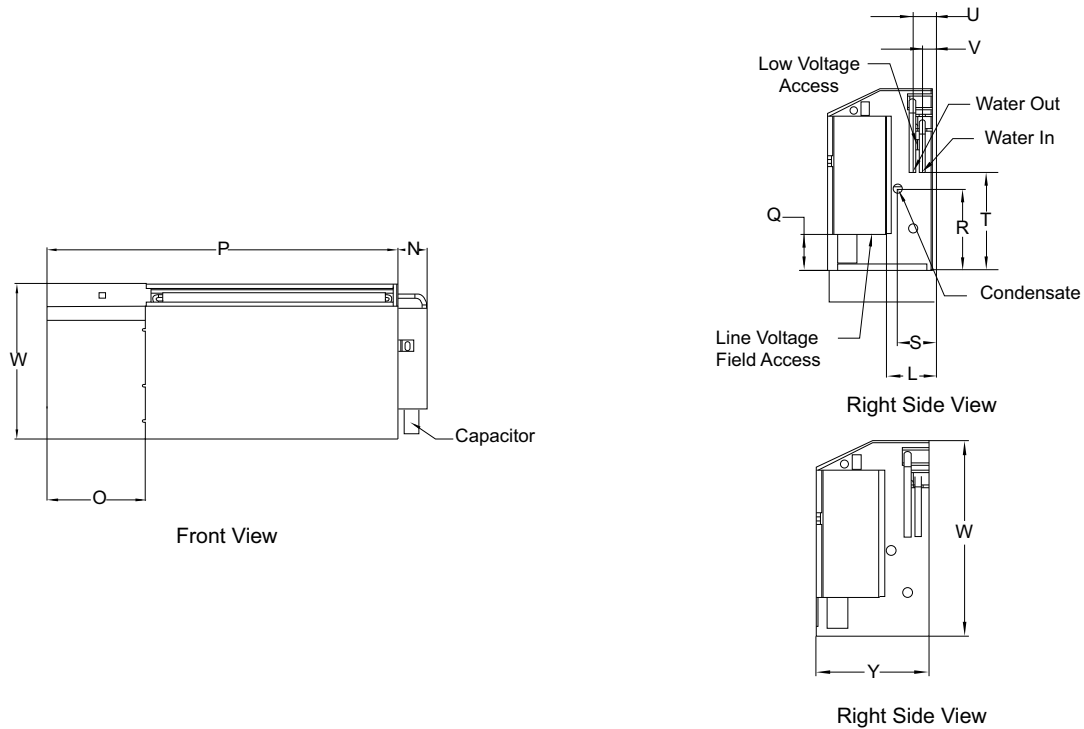

UNIT SIZE ^{a,b}	WATER CONNECTIONS	CABINET LENGTH	L	N	O	P	Q	R	S	T	U
			Electrical Box to Back of Chassis	Electrical Box Width	Control Panel Width	Chassis Width	Electrical Box Height from Sub-base	Condensate Height from Sub-base	Condensate Depth from Rear	Water Connection Height from Sub-base	Water Out Depth from Sub-base Rear
50PEC 009-018	RH	—	5.00	3.50	12.00	42.88	3.87	8.75	4.00	10.00	2.25

UNIT SIZE	V	W	Y	CONDENSER WATER CONNECTIONS (in.)	PERMANENT WASHABLE FILTER SIZE (in.)
	Water In Depth from Sub-base Rear	Chassis Height	Chassis Depth		
50PEC 009-018	1.25	19.75	11.00	5/8 Tube	—

NOTE(S):

- a. All dimensions in inches unless otherwise noted. All dimensions within ± 0.12 inch. Specifications subject to change without notice.
- b. When installing unit in cold climates, an outside air damper must be provided to prevent possible condenser freeze-up. Sub-base is not included.

50PEC Series WSHP Operating Limits

FLUID TYPE	LIMIT	COOLING	HEATING	
Air	Minimum Ambient (°F)	50	40	
	Maximum Ambient (°F)	100	85	
	Rated Ambient (°F)	80	68	
	Minimum Entering (°F db / wb)	65/57	45	
	Maximum Entering (°F db / wb)	95/85	80	
	Rated Entering (°F)	80/67	68/57	
Liquid	Minimum Entering (°F)	50	20	
	Max Entering (°F)	110	80	
	Rated Entering (°F)	Water Loop	86	68
		Ground Loop	77	32
		Ground Water	59	50
	Anti-Freeze Requirement (LWT / EWT °F)	<40 / <50		
	Maximum Operating Water Pressure (psi / kPa)	450 psi / 3100 kPa		
Minimum Operating Flow Rate (gpm / ton)	1.5			

LEGEND

db	— Dry Bulb
EWT	— Entering Water Temperature
LWT	— Leaving Water Temperature
wb	— Wet Bulb

Blower Performance Data

50PEC UNIT	MOTOR SPEED	FACTORY SETTING	CFM AT 0.0 in. wg ^a	
			Cooling ^b	Heating
09	High		320	350
	Low	X	315	345
12	High		480	510
	Low	X	460	490
15	High		460	500
	Low	X	440	480
18	High	X	460	500
	Low		440	480

NOTE(S):

- Ductless system; only rated at an external static pressure of 0.00 in. of water column.
- Cooling CFM based on Wet Coil and Standard Filter - 1/2 in. Washable Aluminum.

Electrical Data — 50PEC Units With or Without Disconnect

50PEC MODELS	RATED VOLTAGE	VOLTAGE MIN/MAX	COMPRESSOR			BLOWER MOTOR		TOTAL UNIT FLA	MCA	MOP	COMPRESSOR SERVICE		
			Qty	RLA	LRA	FLA	Hp				Cold Winding Resistance (Ω)		Run Capacitor (μF/V)
											Single Phase: R-C	Single Phase: S-C	
009	208-230/1/60	197/253	1	3.2	22.2	0.9	0.10	4.1	4.9	15	2.95	7.35	15/370
	265-277/1/60	239/291	1	2.6	18.8	0.7	0.10	3.3	4.0	15	4.27	10.74	10/440
012	208-230/1/60	197/253	1	4.4	27.9	0.8	0.25	5.2	6.3	15	2.32	5.93	20/370
	265-277/1/60	239/291	1	3.5	22.2	0.8	0.25	4.3	5.2	15	3.47	8.69	15/440
015	208-230/1/60	197/253	1	5.2	29.0	0.8	0.25	6.0	7.3	15	2.31	5.45	25/450
	265-277/1/60	239/291	1	4.2	20.0	0.8	0.25	5.0	6.1	15	3.58	7.39	15/440
018	208-230/1/60	197/253	1	7.3	39.0	0.8	0.25	8.1	9.9	15	1.97	1.42	50/440
	265-277/1/60	239/291	1	5.8	31.0	0.8	0.25	6.6	8.1	15	2.54	1.87	30/440

LEGEND

- FLA** — Full Load Amps
- Hp** — Horsepower
- MCA** — Minimum Circuit Amps
- MOP** — Maximum Overcurrent Protection
- LRA** — Locked Rotor Amps
- RLA** — Rated Load Amps

Aquazone™ water source heat pumps are available in a flexible, efficient array of models and sizes, which can be used for extensive variety of commercial building types that has several temperature control zones, some of which need to be heated while others need to be cooled. The WSHP system is an especially good choice for potential energy savings from heat-recovery capabilities to efficiently transfer heat between areas.

The design of WSHP units is adaptable, making them suitable for various water loop, ground water, and ground loop systems. Aquazone™ products provide optimal energy efficient solutions and adapt to the most challenging design requirements.

Water loop system

Water loop (or boiler/tower) system applications typically include a number of units plumbed to a common piping system. For optimal performance, this system should be designed between 1.5 and 4 gpm per ton of cooling capacity. The system is comprised of highly efficient packaged reverse cycle heat pump units interconnected by a water loop. The water circuit serves as both a sink and source for heat absorption and rejection and is designed for entering water temperatures between 50 and 80°F. Within this temperature range units can heat or cool as required from the same water source. Transferring heat from warm to cold spaces in the building, whenever they coexist, conserves energy rather than creating new heat.

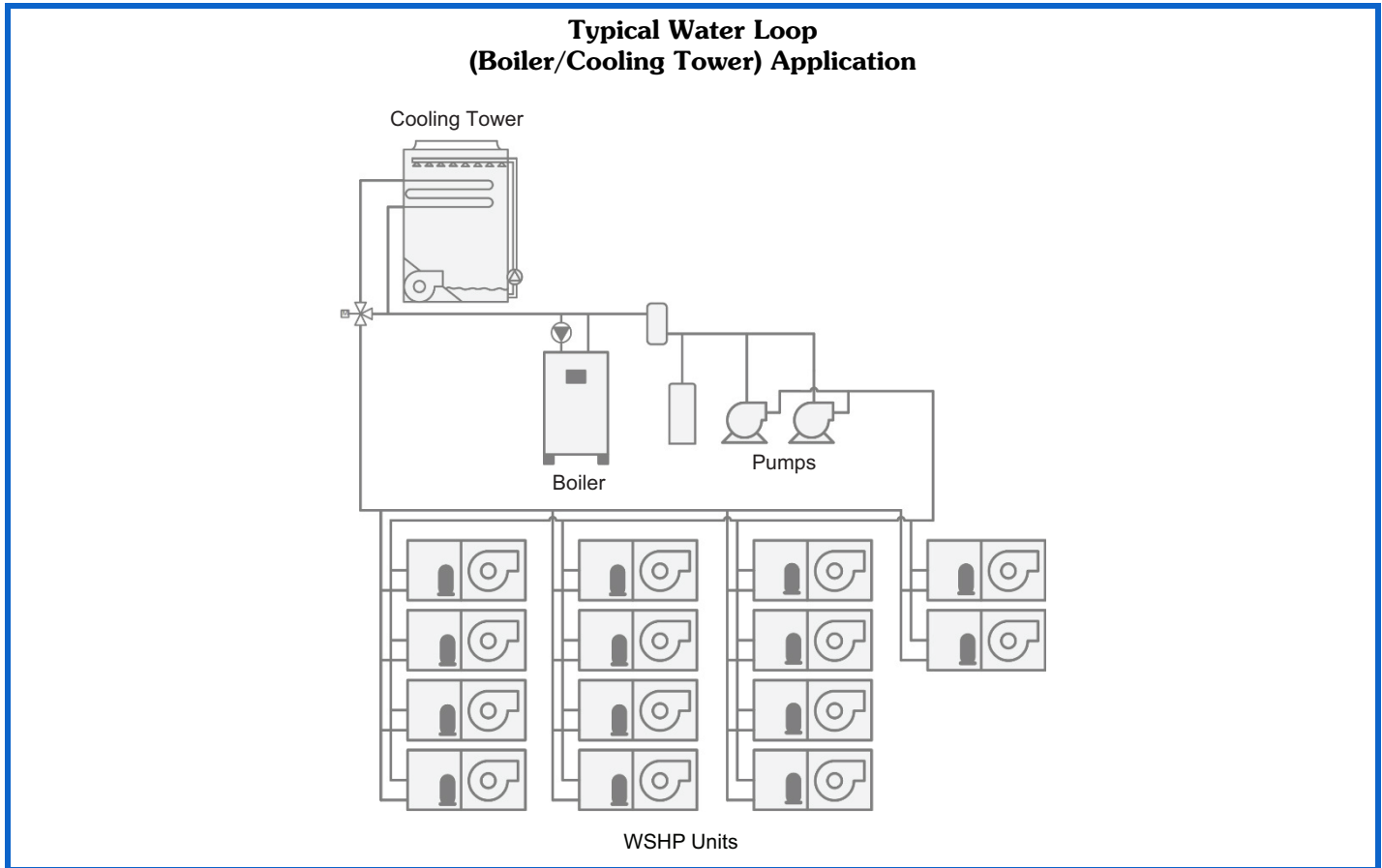

Ground loop systems

The benefit of ground source applications lies in utilizing the earth's stable temperatures to maintain appropriate water loop temperatures. There are many commonly specified designs for ground loop applications. Typical designs include vertical and horizontal loops:

- **Horizontal Ground Loop** — This system is used when adequate space is available, and trenching can be easily accomplished. A series of parallel pipes are laid out in trenches 3 to 6 ft below the ground surface, and then back-filled. Often, multiple pipes are used to maximize the heat transfer capability of each trench. The amount of pipe and the size of the ground loop field are based

on ground conditions, heating, and cooling requirements of the application and system design.

- **Vertical Ground Loop** — This system is used in vertical borehole applications. This design is well suited for retrofit applications when space is limited or where landscaping is already complete and minimum disruption of the site is desired. The vertical ground loop system contains a single loop of pipe inserted into a hole. The hole is back-filled and grouted after the pipe is inserted. The completed loop is concealed below ground. The number of loops required depends on ground conditions, heating and cooling requirements, and the depth of each hole.

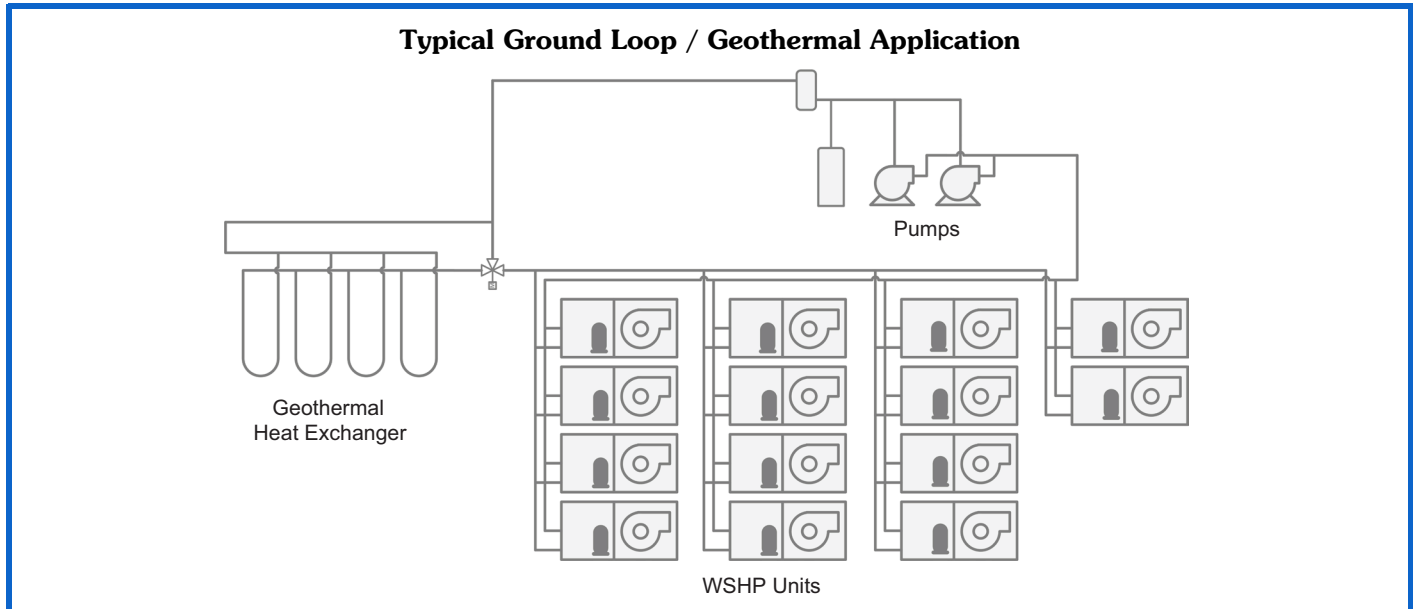

Ground water systems

This system is used where ground water is plentiful. In this application, ground water is pumped through supply piping from the well to the building. The water is then pumped back into the ground through a discharge well as it leaves the building. An additional heat exchanger is usually installed between the building water piping system and the ground water piping system to isolate WSHP units from

contamination. This design limits the amount of piping and excavation required. Aquazone™ units come with an extended range coil (20 to 110°F) for open or closed loop systems. To conserve water on this type of system, a slow opening/closing solenoid valve is recommended. Depending on loop water temperatures, a water regulating valve may be needed.

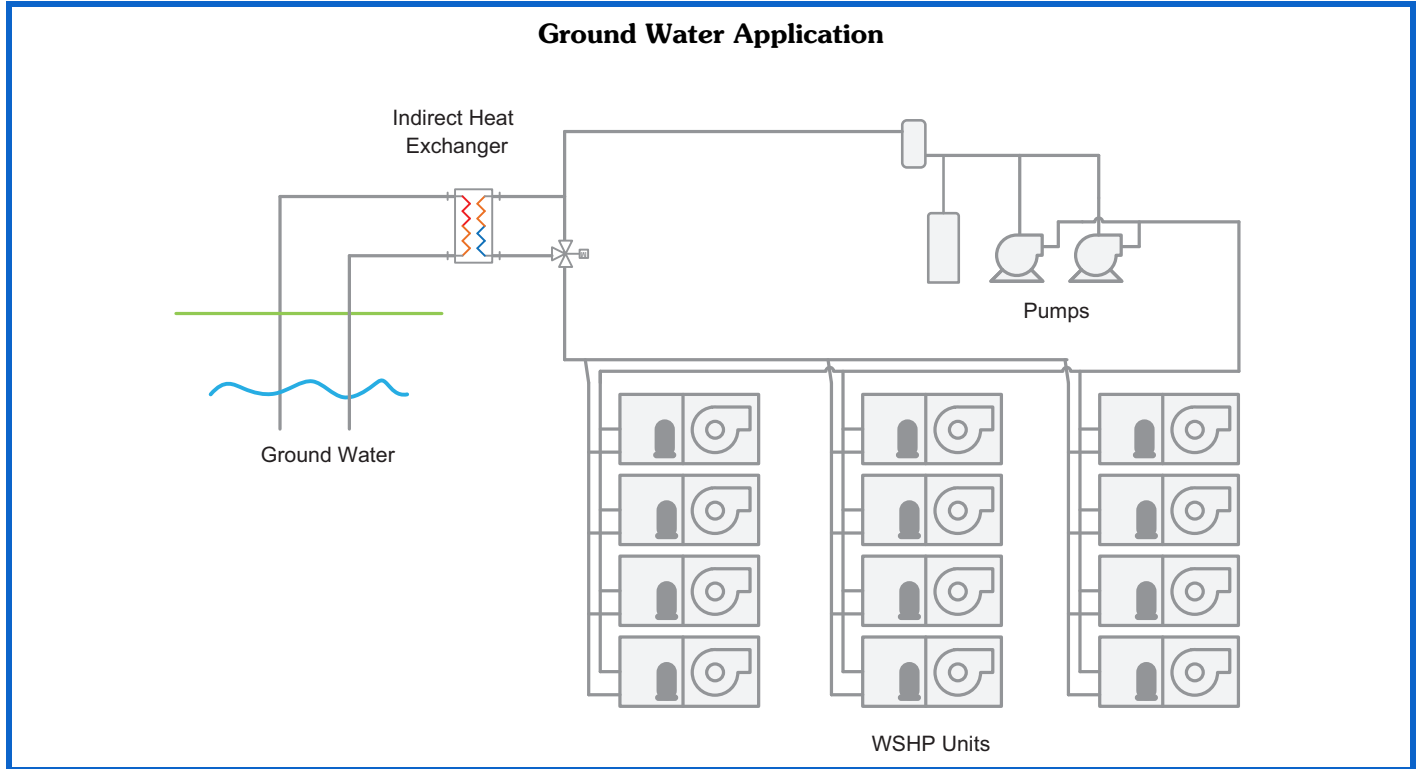

Application data (cont)



Surface Water System

This system is typically located near a lake, pond, well, or other water sources to maintain closed loop water temperatures. In this application, the loop can be submerged

in a series of coils beneath the water surface. The number of coils required depends on system load and design. This application requires minimum piping and excavation.

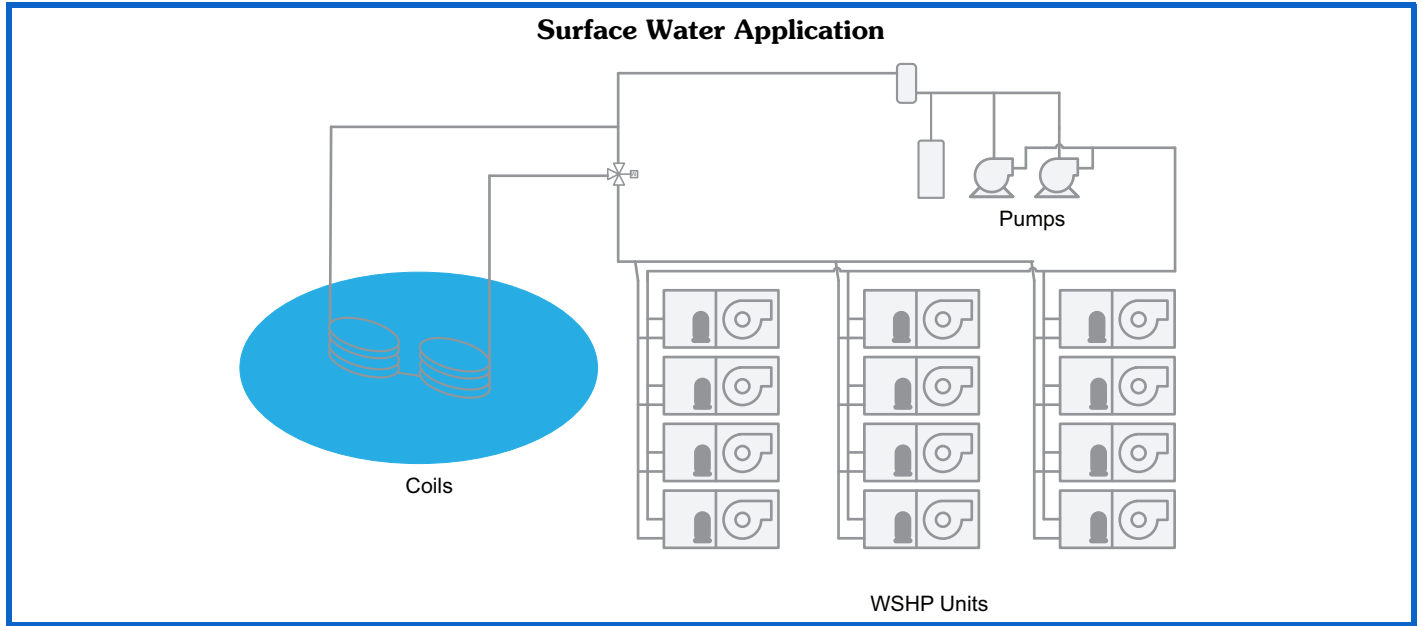

Hybrid Systems

In some applications, it may be beneficial to incorporate a cooling tower or boiler into the ground loop system to reduce the overall cost. A hybrid system discards excess

heat into the air and increases the cooling performance of the ground loop.

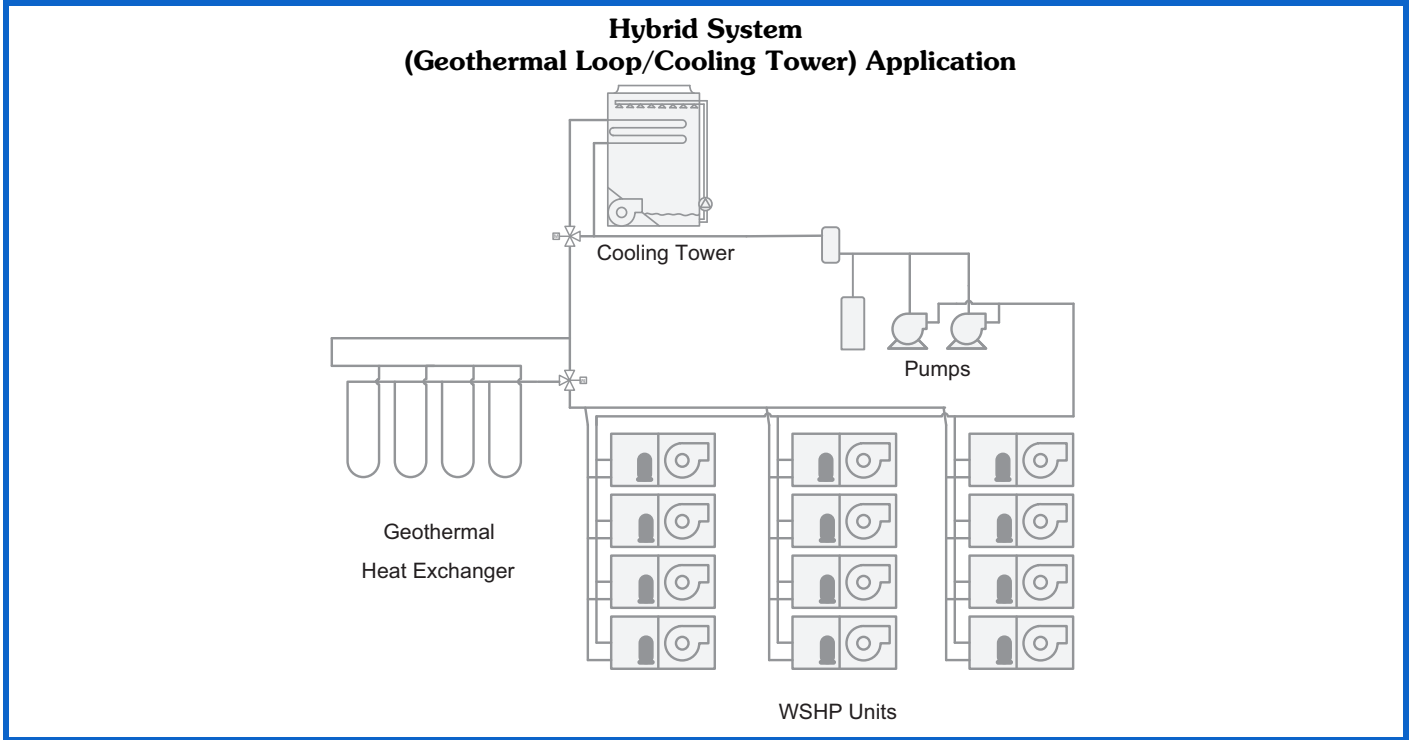

Freeze protection

Applications where systems are exposed to outdoor temperatures below freezing (32°F) or leaving water temperatures drop below 40°F must be protected from freezing. The most common method of protecting water systems from freezing is adding glycol concentrations into the water. Design care should be used when selecting both the type and concentrations of glycol used due to the following:

- Equipment and performance may suffer with high concentrations of glycol and other antifreeze solutions.
- Loss of piping pressure may increase greatly, resulting in higher pumping costs.
- Higher viscosity of the mixture may cause excess corrosion and wear on the entire system.
- Acidity of the water may be greatly increased, promoting corrosion.
- Glycol promotes galvanic corrosion in systems of dissimilar metals. The result is corrosion of one metal by the other, causing leaks.

Water quality

In some applications, maintaining proper water quality may require higher corrosion protection for the water-to-refrigerant heat exchanger. Water quality varies from location to

location and is unique for each job. Water characteristics such as pH value, alkalinity, hardness, and specific conductance are important when considering any WSHP application. Water typically includes impurities and hardness that must be removed. The required treatment will depend on the water quality as well as type of system. Water problems fall into three main categories:

- Scale formation caused by hard water reduces the heat transfer rate and increases the water pressure drop through the heat exchanger. As water is heated, minerals and salts are precipitated from a solution and deposited on the inside surface of the pipe or tube.
- Corrosion is caused by absorption of gases from the air coupled with water on exposed metal. Corrosion is also common in salt-water areas.
- Organic growths such as algae can reduce the heat transfer rate by forming an insulating coating on the inside tube surface. Algae can also promote corrosion by pitting.

NOTE: In most commercial water loop applications, Aquazone™ WSHP units use copper water-to-refrigerant heat exchanger. Units can and should be equipped with a cupronickel heat exchanger for applications where water is outside the standard contaminant limits for a copper heat exchanger.

Water Quality Guidelines

CONDITION	HX MATERIAL ^a	CLOSED RECIRCULATING ^b	OPEN LOOP AND RECIRCULATING WELL ^c		
Scaling Potential — Primary Measurement					
Above the given limits, scaling is likely to occur. Scaling indexes should be calculated using the limits below.					
pH/Calcium Hardness Method	All	N/A	pH < 7.5 and Ca Hardness, <100 ppm		
Index Limits for Probable Scaling Situations (Operation outside these limits is not recommended.)					
Scaling indexes should be calculated at 150°F for direct use and at 90°F for indirect HX use. A monitoring plan should be implemented.					
Ryznar Stability Index	All	N/A	6.0 to 7.5 If > 7.5 minimize steel pipe use.		
Langelier Saturation Index	All	N/A	-0.5 to +0.5 If <=0.5 minimize steel pipe use. Based upon 150°F direct well, 85°F indirect well HX.		
Iron Fouling					
Iron Fe ²⁺ (Ferrous) (bacterial iron potential)	All	N/A	<0.2 ppm (Ferrous) If Fe ²⁺ (ferrous) >0.2 ppm with pH 6 to 8, O ₂ <5 ppm, check for iron bacteria.		
Iron Fouling	All	N/A	<0.5 ppm of Oxygen Above this level deposition will occur.		
Corrosion Prevention^d					
pH	All	6 to 8.5 Monitor/treat as needed.	6 to 8.5 Minimize steel pipe below 7 and no open tanks with pH <8.		
Hydrogen Sulfide (H ₂ S)	All	N/A	<0.5 ppm At H ₂ S>0.2 ppm, avoid use of copper and cupronickel piping or HXs. Rotten egg smell appears at 0.5 ppm level. Copper alloy (bronze or brass) cast components are acceptable to <0.5 ppm.		
Ammonia Ion as Hydroxide Chloride, Nitrate and Sulfate Compound	All	N/A	<0.5 ppm		
Maximum Chloride Levels	Copper Cupronickel 304 SS 316 SS Titanium	N/A N/A N/A N/A N/A	Maximum allowable at maximum water temperature.		
			50°F (10°C)	75°F (24°C)	100°F (38°C)
			<20 ppm	NR	NR
			<150 ppm	NR	NR
			<400 ppm	<250 ppm	<150 ppm
<1000 ppm	<550 ppm	<375 ppm			
>1000 ppm	>550 ppm	>375 ppm			
Erosion and Clogging					
Particulate Size and Erosion	All	<10 ppm of particles and a maximum velocity of 6 fps. Filtered for maximum 800 micron size.	<10 ppm (<1 ppm "sandfree" for reinjection) of particles and a maximum velocity of 6 fps. Filtered for maximum 800 micron size. Any particulate that is not removed can potentially clog components.		
Brackish	All	N/A	Use cupronickel heat exchanger when concentrations of calcium or sodium chloride are greater than 125 ppm are present. (Seawater is approximately 25,000 ppm.)		

NOTE(S):

- Heat exchanger materials considered are copper, cupronickel, 304 SS (stainless steel), 316 SS, titanium.
- Closed recirculating system is identified by a closed pressurized piping system.
- Recirculating open wells should observe the open recirculating design considerations.
- If the concentration of these corrosives exceeds the maximum allowable level, then the potential for serious corrosion problems exists.
Sulfides in the water quickly oxidize when exposed to air, requiring that no agitation occur as the sample is taken. Unless tested immediately at the site, the sample will require stabilization with a few drops of one Molar zinc acetate solution, allowing accurate sulfide determination up to 24 hours after sampling. A low pH and high alkalinity cause system problems, even when both values are within ranges shown. The term pH refers to the acidity, basicity, or neutrality of the water supply. Below 7.0, the water is considered to be acidic. Above 7.0, water is considered to be basic. Neutral water registers a pH of 7.0.
To convert ppm to grains per gallon, divide by 17. Hardness in mg/l is equivalent to ppm.

LEGEND

- HX** — Heat Exchanger
N/A — Design Limits Not Applicable Considering Recirculating Potable Water
NR — Application Not Recommended
SS — Stainless Steel

Condensate drainage

Connect the console unit condensate drain to the building condensate drain with a flexible, non-pressure rated plastic hose. Be sure to avoid kinks in this hose to ensure an unobstructed flow of condensate from the unit to the drain. The condensate hose's horizontal run is usually too short to pose any drainage problems; however, make sure this line is pitched at least 1 in. for every 10 ft of run (in the direction of the flow) to avoid drainage problems. Avoid low points and unpitched piping since dirt collects in these areas and may cause stoppage and overflow.

Flow balancing

Water source heat pumps are designed and selected to provide a specific amount of cooling and heating capacity at specific operating conditions. While all HVAC equipment is designed around specific return and supply air conditions, WSHPs differentiate themselves by also requiring specific water loop conditions. As a result, it is extremely important that these water loop conditions remain as constant as possible during operation of the WSHP to ensure that both cooling and heating demands are met. One major component of these water loop conditions is the water loop flow rate, often referenced as the GPM or gallons per minute. One method of controlling the GPM is by manually balancing each WSHP, however this is often very time consuming (each WSHP requires manual balancing), and the flow rate through a manually balanced valve tends to fluctuate over time, often requiring frequent re-balancing. A better method to ensure a constant water loop flow rate at each WSHP is to use an automatic flow control device, or an auto-flow regulator. An auto-flow regulator is a pressure independent automatic flow limiting valve, with the main component being an internal flow cartridge that is factory set to a specific flow rate, or GPM. Auto-flow regulators are utilized at each WSHP (each WSHP will have its own auto-flow regulator) and the auto-flow regulator will maintain the designed GPM over a wide water loop pressure differential. Thus, as the water loop pressure changes (which can be common in systems as different WSHPs on the same water loop are turning on/off and their isolation valves open/close as a result), the water loop flow rate to each WSHP remains constant. Additionally, the system installation is much easier with autoflow regulators compared to manually balanced systems, and the "fluctuation" seen in manually balanced systems is no longer an issue.

Acoustical design

Sound power levels represent the sound that the source, the WSHP unit, produces with no regard to attenuation between the source and the space. Acoustical design goals are necessary to provide criteria for occupied spaces.

These goals help ensure that people can be comfortable and communicate effectively over the background noise of the air-conditioning system and other background noise sources.

Acoustical design goals are desirable sound pressure levels within a given conditioned space and are represented by noise criteria (NC) curves. Noise criteria (NC) curve levels represent a peak over a full frequency spectrum. A high value in a low frequency band has the same effect on NC level as a lower value in a high frequency band. It is important that sound levels be balanced over the entire spectrum relative to the NC curve. The lower the NC criteria curve, the more stringent the room acoustical design must be to meet the design goals.

It is important to know how to convert the unit ratings from sound power (L_w) to sound pressure (L_p). This conversion depends on the specifics of the installation's acoustical environment. Assessing an area's acoustical design requires that you compare the sound pressure (L_p) with the NC curve for the selected area.

The resulting calculations are compared to the NC curve selected for the area to assess the acoustical design.

Some of the factors that affect conversion of sound power to sound pressure and consequent NC level include:

- type of acoustical ceiling
- use of metal or flex duct
- absorption in the occupied space
- location in the occupied space
- open or closed layout plan
- use of open or ducted returns
- orientation of unit to occupant
- use of lined or unlined duct

WSHP sound control

Analyzing the projected sound level in the conditioned space caused by a WSHP unit is quite involved. The key is to have good sound power ratings (L_w) in dB on the equipment to determine the ductwork, ceiling and room sound attenuation effect.

Console units

With console units, the fan and compressor are located within the space, and only the casing design attenuates the transmission of sound sources into the space. The designer should carefully review the manufacturer's acoustical data when selecting console units and use lower fan speeds to minimize space noise.

Selection procedure



The electronic catalog (eCAT) selection tool is a web-based selection program recommend for all WSHP equipment selections. The tool provides guided configuration of WSHP units, all associated performance data, and comprehensive and professional equipment reports/submittals.

Selection inputs

The following is a list of the primary information needed to select a water source heat pump unit.

Electrical

WSHP units are available in a variety of electrical configurations. The Voltage / Phase/ Hertz requirements for the project will need to be defined for the WSHP unit.

System Parameters

Entering Water Temperature (EWT)

The design entering water temperature will typically be the same for all units within the same source water loop meaning there will be a single set of design cooling and heating source water loop setpoints.

Fluid Type

The fluid type needs to be defined for the source water loop. This will typically be 100% water or a percentage of antifreeze concentration.

Altitude

When the altitude is defined the program will automatically apply any derates to the unit capacity associated with the varying air conditions.

The screenshot shows the 'System Parameters Screen' with the following fields:

- Altitude: 0 ft
- Fluid Type: Propylene Glycol
- Cooling Ent. Water Temp: 86.0 F
- Fluid Concentration: 10 %
- Heating Ent. Water Temp: 68.0 F

Design Parameters

Entering Air Temperature (EAT)

The design entering air temperature for both heating and cooling is required. For cooling this will be both a wet bulb and dry bulb temperature and for heating this will be dry bulb only. If outdoor air is being mixed in with the return air of the unit, the EAT will need to be the mixed air condition.

Airflow Rate

Typically, a single airflow rate will be defined for both heating and cooling operation. In general, these units are constant air volume units meaning they are not varying the airflow as a means of capacity or supply air temperature

control. Airflow rates are often selected to maintain around 400 CFM/nominal cooling ton.

External Static Pressure

The external static pressure at the design airflow rate is required. ECAT will automatically factor in the airside pressure drop of optional airside components when evaluating fan performance.

Water Flow Rate

Water flow rate will vary among each unit in a system and is typically selected to maintain a target temperature difference or gpm/nominal ton for either cooling or heating operation.

The screenshot shows the 'Design Parameters Screen' with the following fields:

- Motor Type: Constant Torque ECM
- Fan Speed: AUTO
- External Static: 0.500 in wg
- Airflow Rate: 1000 CFM
- Cooling Ent. Air DB Temp: 75.0 F
- Flow Rate selection: Flow Rate, Flow Rate/Nominal Capacity
- flow Rate: gpm
- flow Rate/capacity: 2.8 gpm/ton
- Cooling Ent. Air WB Temp: 63.0 F
- Heating Ent. Air DB Temp: 68.0 F
- Cooling Ent. Relative Humidity: 51.57 %

Capacity Requirements

Heating and Cooling Loads

Although both heating and cooling loads need to be considered when selecting WSHP units, they are often chosen based on cooling capacity, given that heating output is generally higher.

Unit Configuration

WSHP units are highly configurable with a wide variety of factory installed options and air/water flow configurations. The ECAT selection program will present the available options and configurations available to the particular unit of selection.

Accessories/Warranties/Start-Up

The electronic catalog (eCAT) selection tool integrates a range of field-installed accessories to meet the specific needs of each project. The selection of accessories includes hose kits, isolation/balancing valves, strainers, electric duct heaters, sensors, and thermostats. Beyond the unit's configuration and accessories, the selection process extends to warranty choices and equipment start-up options. This ensures a comprehensive and tailored approach to WSHP systems, allowing for customization based on the unique requirements of each project.

Capacity Requirements Screen

Capacity Requirements

Total Cooling Total Cooling: 26.0 MBH

Total Heating Total Heating: 30.0 MBH

Sensible Cooling Capacity Capacity: 19.0 MBH

Tolerance: 10 %

Selection Outputs / Reports

Performance Report

Upon completing the selection process, the eCAT tool delivers a concise performance report. This report encompasses key unit parameters such as size, model number, and system conditions. Additionally, it includes crucial electrical data and unit performance metrics based on the

specified conditions. The report goes a step further by incorporating the unit's fan curve, offering a visual representation of its airflow characteristics. This concise performance report ensures that users have a clear and easily digestible overview of the chosen WSHP unit, facilitating informed decision-making and streamlined documentation for project evaluation.

Performance Report

Performance Report

Performance Summary

Show Pricing in Reports

Submittal Report

Within the project overview section of the eCAT, users have the option to generate a tailored submittal report.

This customizable report features selectable sections to include essential project documentation.

Sumittal Report

Selection Summary

Quote selections Batch Upgrade CSO Export + New selection

Selection Name	Model	Chiller Arrangement	Capacity	Quantity	Date Modified	Actions
<input type="checkbox"/> 50HQP	50HQP096JCC6B1AB	N/A	096 (8 tons)	1	19/10/2023 02:28 PM	✓ 📄 🗑️ 📄 ⋮

← Prev 1 Next →

Items per page: 100

Selection procedure (cont)



Selectable Sections

- Cover Sheet — Includes project name, tag name and report's generated Date.
- Unit Report — Offers detailed insights into the selected water source heat pump (WSHP), including size, model number, unit size, overall dimensions, weight, electrical data, selected options and accessories and warranty information.
- Certified Drawings — Provides detailed dimensional information about the unit.
- Detailed Performance Report — Offers a comprehensive overview of the WSHP's electrical and performance data, along with its fan curve.
- Guide Specifications — Outlines key installed options and unit's details.
- Acoustical Report — Provides rated sound data of the unit.

Console Water Source Heat Pumps

HVAC Guide Specifications

Size Range: 3/4 to 1-1/2 Nominal Tons

Carrier Model Number: **50PEC**

Part 1 — General

1.01 SYSTEM DESCRIPTION

- A. Install water source heat pumps, as indicated on the plans with capacities and characteristics as listed in the schedule and the specifications that follow. All equipment shall be rated and certified in accordance with ANSI/AHRI/ASHRAE/ISO (American National Standard Institute/Air-Conditioning, Heating and Refrigeration Institute/American Society of Heating, Refrigerating, and Air-Conditioning Engineers/International Organization for Standardization) 13256-1. All equipment shall be tested, investigated, and determined to comply with the requirements of the standards for Heating and Cooling Equipment UL-60335-2-40 for the United States and CSA C22.2 No. 60335-2-40 for Canada, by Intertek Testing Laboratories (ETL). The units shall have AHRI/ISO and ETL-US-C labels.
- B. Units shall be supplied completely factory built and capable of operation with an entering water temperature range from 20 to 110°F. Quality control system shall automatically perform via computer: triple leak check, pressure tests, evacuation and accurately charging of system, detailed heating and cooling mode tests, and quality cross checking all operational and test conditions to pass/fail criteria.
- C. Units shall be individually packaged with wooden skid covered with protective corner posts and plastic stretch wrapping for maximum protection.

1.02 QUALITY ASSURANCE

- A. All equipment listed in this section must be rated in accordance with ANSI/AHRI/ASHRAE/ISO 13256-1 performance standard, latest edition. The applicable units shall have an AHRI/ISO label. Standard cabinet panel insulation shall meet NFPA (National Fire Protection Association) 90A requirements, air erosion and mold growth limits of UL-181, stringent fungal resistance test per ASTM-C1071 and ASTM G21 and shall meet zero level bacteria growth per ASTM (American Society for Testing and Materials) G22.
- B. Units shall be factory tested to verify operation of critical components and verify functionality of control and safety devices.

Part 2 — Product

2.01 EQUIPMENT

- A. General: Units shall be completely assembled, piped, internally wired, and fully charged at the factory.
- B. Unit Cabinet:
 1. Cabinet work shall include two separate integral assemblies: cabinet and sub-base. Cabinet shall be factory fabricated from heavy gauge

galvanized steel, finished with powder coat paint. Cabinet dimensions are in accordance with drawings and are manufactured for left or right water discharge piping. Cabinet shall be single-piece construction. Removal of the cabinet shall give complete side and front access to unit for routine servicing. The cabinet is mounted onto the sub-base and secured with two screws for security. A wall mounting bracket secured to the sub-base shall be provided. Air flow is bottom intake-top discharge. Cabinets will be factory fabricated specifically for left hand or right hand connections as specified. Cabinet shall be slope top style, flat top cabinet is not acceptable.

2. An access door shall be provided to access the unit mounted controller (units with unit mounted controller only).
3. Factory mounted 3-3/8-in. sub-base is constructed of heavy gage painted steel. Cutouts are provided for floor connections and outside air. Includes integral filter mounts to support a bottom mount permanent, washable, aluminum mesh filter. Sub-base shall have integral wall bracket.

C. Chassis:

The unit shall be chassis only, chassis on sub-base, or chassis with sub-base and cabinet. The chassis is of compact design and of the same dimensions for all model sizes. Dimensions must match details on drawings. Chassis mounts directly on support structures provided by the sub-base and shall be removable from the sub-base without dismantling the sub-base. Both the compressor and coil compartment shall be thermally and acoustically insulated, and have removable steel cover plates giving double acoustical protection between the two compartments. Compressor is mounted to the bottom of chassis with a 2-piece basepan to reduce noise transmission and vibration. The compressor access panel shall have a closed cell foam insulation for extra quiet operation. Fiberglass insulation is not acceptable on compressor access panel. The stainless steel condensate drain pan shall be IAQ with positive double slope and be removable without disturbing the evaporator assembly for cleaning as needed.

D. Fan and Motor Assembly:

Unit blower has a high efficiency PSC motor with two speed settings. Motor is direct connected to two double width, double inlet forward curved oversized centrifugal blower wheels that are selected for quiet operation, and balanced to minimize vibration. Blower wheel access is through removable blower inlet rings. Motor and blower assembly shall be removable without removing the chassis.

E. Outside Air Damper (optional):

Unit shall have a factory installed, motorized, 2-position, outdoor air damper.

F. Refrigerant Components:

1. Units shall have a sealed refrigerant circuit including a rotary compressor, a refrigerant metering device, a finned tube refrigerant-to-air heat exchanger, a reversing valve, a coaxial (tube-in-tube) refrigerant-to-water heat exchanger, and safety controls including a high-pressure sensor, a loss-of-charge sensor to protect against loss of refrigerant, and low water temperature (freeze-stat) sensor.
2. Rotary compressors shall have thermal overload protection and shall be located in an insulated compartment to minimize sound transmission. Units shall have the compressor mounted on isolators to reduce noise and vibration transmission.
3. Air Coils shall be coated using an electro coating process for protection against most airborne chemicals.
4. Coaxial (tube in tube) refrigerant-to-water heat exchanger. Refrigerant-to-water heat exchangers shall be of copper inner water tube and steel outer refrigerant tube design rated to withstand 600 psig working refrigerant pressure and 450 psig working water pressure.
5. [Optional] Cupronickel coaxial water-to-refrigerant heat exchangers shall be provided, with cupronickel inner water tube construction.
6. Drain pan shall be constructed of stainless steel to resist corrosion.
7. Reversing valve shall be four-way solenoid-activated refrigerant valves which shall fail to heating operation. If the unit fails to cooling a low-temperature thermostat must be provided to prevent over-cooling of the room.

G. Piping:

1. Copper tubes with a 5/8 in. OD dimension shall be provided on the supply and return water connections for the purpose of forming a sweat connection to field-supplied distribution piping.
2. [Optional] Female Pipe threaded (FPT) connections: A 1/2 in. female pipe threaded fitting shall be factory mounted on the supply and return water connections.

H. Controls and Safeties:

1. Electrical:
 - a. A control box shall be located within the unit and shall contain controls for compressor, reversing valve and fan motor operation.
 - b. Units shall be provided with a factory mounted 2 x 4 junction box with removable cover on the same side as the water connections (left or right) for direct wire connection. This cover may be supplied with a non-fused power disconnect switch for servicing the unit. The unit shall operate with specified voltages, 208/230 volt or 265 volt, single

phase, 60 Hz supply current. Units with power cord and plug are not acceptable.

- c. All 50PEC console units are rated for 5kA SCCR.
- d. Controls and safety devices will be factory wired and mounted within the unit. Controls shall include fan relay, compressor contactor, 24-v transformer, reversing valve coil, and Unit Protection Module (UPM). The standard transformer shall be rated for a minimum 40 va for all sizes, or 50 VA for 265-v units, or 75 va for units with TruVu™ controller. All units shall be name plated for use with time-delay fuses or HACR circuit breakers. Unit controls shall be 24-v and provide heating or cooling as required by the remote thermostat/sensor.
- e. [Optional] A larger transformer rated for at least 75 va Shall be available for all unit sizes and have a push button reset circuit breaker on the secondary power.
- f. Unit shall include a wiring diagram permanently affixed to the inside of the cabinet.
- g. All units shall have a Unit Protection Module (UPM) printed circuit board which implements following equipment safeties:
 - 1) Anti-short cycle time delay (5-minute delay on break).
 - 2) Random start time delay on initial power.
 - 3) Brownout / surge / power interruption protection.
 - 4) 120 second low pressure switch bypass timer.
 - 5) High refrigerant pressure shutdown.
 - 6) Low refrigerant pressure shutdown.
 - 7) Water coil freeze protection shutdown.
 - 8) Air coil freeze protection shutdown.
 - 9) High condensate level shutdown.
 - 10) 24 vac alarm output for remote fault indication.
 - 11) Intelligent alarm reset.
- h. The UPM shall automatically reset after a safety shutdown. Restart the unit if the cause of the shutdown no longer exists (except for low temperature and high condensate level shutdowns). Should a fault re-occur within 60 minutes after reset, then a “hard” lockout will occur. A light-emitting diode (LED) shall annunciate the following alarms: brownout, high refrigerant pressure, low refrigerant pressure, low water temperature and a high level of condensate in the drain pan, refrigerant leak fault. The LED will display each fault condition as soon as the fault occurs. If a hard lockout occurs, then the fault LED

will display the type of fault until the unit is reset.

The UPM shall feature the following field configurable adjustments:

- 1) Lock out reset on thermostat interruption or power reset.
 - 2) Two or four restart attempts before a hard lockout.
 - 3) Test mode (reduces all time delays to 5 seconds for diagnostic work).
 - 4) Air/water coil freeze limit trip.
- i. [Optional] The optional unit mounted controller (UMC) shall provide a tactile touchpad for temperature, fan and mode adjustment and provide a digital display of temperature in either degrees Fahrenheit or Celsius. The unit mounted controller shall provide an LED display for indication of unit operating mode as well as fan speed and fault indication for high or low pressure lockout. Rotary dial electromechanical controls shall not be acceptable. Options and features shall include:
- 1) adjustable temperature set point from 60°F through 80°F (15.5°C through 26.7°C)
 - 2) adjustable temperature differential between 1°F and 6°F (0.6°C and 3.3°C)
 - 3) manual or automatic changeover
 - 4) high and low fan speed control
 - 5) constant fan speed or fan speed cycling with compressor.
 - 6) a 5-minute anti-short cycling delay
 - 7) random start
 - 8) a 90-second low pressure bypass timer.
 - 9) intelligent reset to allow unit to automatically restart after 5 minutes if a fault is no longer active
- j. [Optional] Units shall have all the features above (UPM) and additionally TruVu™ DDC controller shall have an advanced controls logic and include following features:
- 1) Two-speed fan control. Controller shall automatically, based upon space temperature input, operate the fan at the lowest of 2 selectable speeds to achieve space temperature set point.
 - 2) Two-position OA (outdoor air) damper.
 - 3) Modulating OA damper with DCV (demand controlled ventilation).
 - 4) Scheduling.
 - 5) Adaptive optimal start.
 - 6) Equipment performance monitoring.

7) Alarm status.

TruVu™ controller must be capable of communicating over BACnet®¹ IP, supporting direct connection or daisy chain topologies using BACnet/IP for seamless integration into building automation systems, and shall have the ability to be viewed in the TruVu Equipment Touch (ET), or field assistant user interface.

- k. [Optional] Non-fused electrical disconnect shall be installed on the unit.
- l. [Optional] Energy management switch to enable remote operation of WSHP (water source heat pump).
- m. [Optional] Pump-valve relay to enable a pump/valve operation when calling for compressor operation.
- n. [Optional] Compressor status relay shall be provided to monitor a status of the compressor via normally open set of dry contact.
- o. [Optional] Outdoor air dampers shall be motorized with a spring return motor solenoid. The damper shall open when the damper switch is set to “ON” and a request for the compressor to run is provided by the system.

I. Accessories:

1. Hydronic accessories:

a. Hose Kits

All units shall be connected to main water supply and return headers with hoses. The hoses shall be 2 or 3 feet long, braided stainless steel rated to 400 psig at 265°F. Hoses may contain optional ball valves with P/T ports, Y strainers with blow down valves and/or auto flow regulators as specified in the schedule.

- #### b. Two-position motorized isolation valve (2-way solenoid valve) with end switch is available for field installation. The two-way motorized solenoid valve is rated for a 125 psig working pressure. The valve shall be field wired to open with compressor operation.

c. Ball Valves (Brass Body)

Valves shall be available for shutoff and balancing water flow. Available with memory, memory stop, and pressure temperature ports (600WOG at 325°F).

d. Y Strainers (Bronze Body)

Strainers are “Y” type configuration with a brass cap. Strainer screen shall be made of stainless steel (600WOG at 325°F).

1. Third-party trademarks and logos are the property of their respective owners.

2. Controls accessories:
 - a. Carrier commercial thermostat controls are available as follows:
 - 1) Edge® Pro 7-day programmable thermostat offers 2-stage heat, 2-stage cool, remote contact input, remote sensor capability, pre-occupancy purge, soft start, manual/auto changeover, 4 settings per day, 24 vac, backlit LCD, keypad lockout, no batteries required, 5-minute compressor protection, never lost memory, 3 security levels, and temperature display in °F or °C.
 - 2) Comfort Pro Programmable Thermostat, 2-stage Heat /2-stage Cool G/E, plus 1-stage auxiliary or emergency heat HP&WSHP, or 2- stage cool/heat only, Touch n Go™ prog. (OCC/UNOCC/LIMIT), Passcode protection, remote sensor capability with override, random start, Manual/Auto-Changeover, Outdoor/supply/return temp, hospitality mode, option battery powered.
 - 3) Carrier Connect™ Wi-Fi 7-day programmable/non-prog; 4.3 in. touch screen, web enabled (portal), smartphone app, 1-2 stage heat/1-3 stage cool, G/E, HP (with 2-stage aux heat), remote sensor capability, manual/auto-changeover, humidify/dehumidify/Humidi-MiZer®.
 - 4) Non-Branded Wi-Fi 7-day programmable/non-prog; 4.3 in. touch screen, web enabled (portal), smartphone app, 1-2 stage heat/1-3 stage cool, G/E, HP (with up to 2-stage aux heat), remote sensor capability, manual/auto-changeover, humidify/dehumidify/Humidi-MiZer.
 - b. ComfortVu BACnet Thermostat, 24 VAC Thermostat, offers a large backlit LCD display and intuitive push-button controls for easy operation, BACnet® MS/TP port, 2 universal inputs, 2 universal outputs, and 4 relay outputs, it allows control over up to 3 stages of heating and 2 stages of cooling, along with up to 3 fan speeds.
 - c. ZS sensors for TruVu™ DDC (direct digital controls) control option. Sensors are available as follows, and all sensors below offer monitoring of space temperature only, or space temperature and CO₂, or space temperature and humidity, or space temperature and CO₂ and humidity.
 - 1) ZS Standard sensor with a communication port.
 - 2) ZS Plus sensor with communication port, occupancy status indicator, local occupancy override and set point adjustment.
 - 3) ZS Pro sensor with communication port, occupancy status indicator, local occupancy override, set point adjustment, LCD (liquid crystal diode) display, alarm indicator and fan speed control.
 - 4) ZS Pro-F sensor with communication port, occupancy status indicator, local occupancy override, set point adjustment, LCD display, alarm indicator, fan speed control, cooling/heating/fan only mode control and F to C conversion.
 - 5) TruVu™ Equipment Touch (ET) for unit start-up and commissioning shall be available in 7 and 10 in. touch screen sizes for panel or wall mounting. All point objects will have the ability to be viewed in the TruVu™ ET user interface.

