

# Small Rooftop Units 3 to 12.5 Tons

## Ultra Low Leak Vertical EconoMiSer® X Accessory

# Installation Instructions

Part No: CRECOMZR067A01, CRECOMZR069A01 and CRECOMZR071A01

## CONTENTS

	Page
<b>SAFETY CONSIDERATIONS</b> .....	1
<b>GENERAL</b> .....	1-3
<b>Accessories List</b> .....	3
<b>Compliance</b> .....	3
<b>INSTALLATION</b> .....	3-17
<b>Wiring Instructions for 1 and 2 Speed Units</b> .....	9
<b>W7220 Economizer Controller</b> .....	9
<b>W7220 Economizer Module Wiring</b> .....	15
<b>START-UP</b> .....	17, 18
<b>Cooling, Unit with EconoMiSer® X</b> .....	17
<b>Heating with EconoMiSer® X</b> .....	17
<b>Demand Controlled Ventilation</b> .....	18
<b>TROUBLESHOOTING</b> .....	18, 19
<b>Power Loss (Outage or Brownout)</b> .....	18
<b>Alarms</b> .....	18
<b>Clearing Alarms</b> .....	18

## SAFETY CONSIDERATIONS

Installation of this accessory can be hazardous due to system pressures, electrical components and equipment, and equipment locations (such as a roof or elevated surface). Only trained qualified installers and service technicians should install, start-up, and service this equipment.

When installing this accessory, observe precautions in the literature and on any labels attached to the equipment and all other safety precautions may apply.

- Follow all safety codes
- Wear safety glasses and work gloves
- Use care in handling and installing the accessory

It is important to recognize safety information. This is the safety-alert symbol . When you see this symbol on the unit and in instructions or manuals, be alert to the potential for personal injury.

Understand the signal words DANGER, WARNING, CAUTION, and NOTE. These words are used with the safety-alert symbol. DANGER identifies the most serious hazards which will result in severe personal injury or death. WARNING signifies hazards which could result in personal injury or death. CAUTION is used to identify unsafe practices, which may result in minor personal injury or product and property damage.

NOTE is used to highlight suggestions which will result in enhanced installation, reliability, or operation.

### **WARNING**

Electrical shock can cause personal injury and death. Shut off all power to this equipment during installation. There may be more than one disconnect switch. Tag all disconnect locations to alert others not to restore power until work is completed.

### **CAUTION**

Failure to follow this caution may result in personal injury. Sheet metal parts may have sharp edges or burrs. Use care and wear appropriate protective clothing, safety glasses, and gloves when handling parts and servicing rooftop units.

### **CAUTION**

Failure to follow this caution may result in personal injury and damage to the unit. Cover the duct opening as a precaution so objects cannot fall into the return duct opening. Be sure to remove the cover when installation is complete.

## GENERAL

The EconoMiSer® X system utilizes the latest technology available for integrating the use of free cooling with mechanical cooling for packaged rooftop units. The solid-state control system optimizes energy consumption, zone comfort, and equipment cycling by operating the compressors when the outdoor-air temperature is too warm, integrating the compressor with outdoor air when free cooling is available, and locking out the compressor when outdoor-air temperature is too cold. Demand control ventilation is supported.

This EconoMiSer X system can be used with 1, 2, or 3 speed (48/50LC 14) units.

The EconoMiSer X system utilizes gear-drive technology with a direct-mount spring return actuator that will close upon loss of power. The EconoMiSer X system comes standard with an outdoor air temperature sensor, mixed air temperature sensor (also called Supply Air Temperature Sensor). Outdoor enthalpy, indoor (return) dry bulb or enthalpy, and CO<sub>2</sub> sensors are available for field installation.

Standard barometric relief dampers provide natural building pressurization control. An optional power exhaust system is available for applications requiring even greater exhaust capabilities. The power exhaust set point is adjustable at the EconoMiSer X controller.

See Table 1-3 for package usage. See Table 4 for package contents. See Table 5 for sensor usage.

**IMPORTANT:** These economizers meet all the economizer requirements as laid out in ASHRAE 90.1-2016 and California's Title 24-2016 mandatory section 120.2 (fault detection diagnostics) and prescriptive section 140.4 (life-cycle tests, damper leakage, sensor accuracy, etc). Economizer must be installed perfectly square to avoid damper leakage or damper binding. Squareness tolerance is  $\pm 1/32$  inch.

**IMPORTANT:** Read these instructions completely before attempting to install the accessory economizer.

**Table 1 — Carrier Usage Chart**

CARRIER MODEL NUMBER	ECONOMIZER® X PART NUMBER
48/50HC, LC 04-06 48/50TC 04-07 50TCQ 04-07 50HCQ 04-06 50KCQ 04-06	CRECOMZR067A01
48/50HC 07-12 48/50LC 07 48/50TC 08-14 50TCQ 08-12 50HCQ 07-09	CRECOMZR069A01
48/50HC 14 48/50LC 08-14 48/50TC 16 50TCQ 14 50HCQ 12	CRECOMZR071A01

**Table 2 — Bryant Usage Chart**

BRYANT MODEL NUMBER	ECONOMIZER® X PART NUMBER
581J/551J 04 547J/558J/559J/582J 04-06 548J 04 and 05 549J 04	CRECOMZR067A01
581J/551J 05 and 06 580J/558J 07 548J 06 and 07 549J 05 and 06	CRECOMZR069A01
581J/551J 14 580J/558J 14 548J 14 549J 12	CRECOMZR071A01

**Table 3 — ICP Usage Chart**

ICP MODEL NUMBER	ECONOMIZER® X PART NUMBER
RGH/RAH 036-060 RGS/RAS 036-060 RHS 036-072 RHH 036 and 048	CRECOMZR067A01
RGH/RAH 072-120 RAS/RGS 090-120 RHH 072-102	CRECOMZR069A01
RGH/RAH 150 RAS/RGS 150 RHS 150 RHH 120	CRECOMZR071A01

**Table 4 — Package Contents**

ECONOMIZER PART NUMBER	QTY	CONTENTS
CRECOMZR067A01, CRECOMZR069A01	1	Hood Top
	2	Hood Sides
	1	Hood Divider
	1	Aluminum Filter
	18	Screws
	1	EconoMiSer® X Assembly
	1	HH79AH001 MAT Sensor and Harness
	1	48TMHSRSE - A20 Harness
CRECOMZR071A01	1	Hood Top
	2	Hood Sides
	1	Hood Divider
	1	Hood Filter Divider
	2	Aluminum Filters
	1	Hardware Bag
	1	EconoMiSer Assembly
	1	HH79AH001 MAT Sensor and Harness
1	48TMHSRSE - A20 Harness	

**Table 5 — EconoMiSer® X Sensor Usage**

APPLICATION	ECONOMIZER X WITH OUTDOOR AIR DRY BULB SENSOR		
	Accessories Required		
<b>Outdoor Air Dry Bulb</b>	The HH79AH001 outdoor air dry bulb sensor is factory installed on economizer.		
<b>Mixed Air Sensor</b>	HH79AH001 provided with economizer and field-installed in blower compartment.		
<b>Single Enthalpy</b>	HH57AC081		
<b>Differential Dry Bulb or Enthalpy</b>	HH57AC081		
<b>CO<sub>2</sub> for DCV Control using a Wall-Mounted CO<sub>2</sub> Sensor</b>	33ZCSENCO2 or CGCDXSEN004A00		
<b>CO<sub>2</sub> for DCV Control using a Duct-Mounted CO<sub>2</sub> Sensor</b>	33ZCSENCO2 or CGCDXSEN004A00* and 33ZCSENCO2 or CGCDXASP00100†	OR	CRCBDIOX005A00**

\* Accessory CO<sub>2</sub> sensors.

† Accessory aspirator boxes required for duct-mounted applications.

\*\* CRCBDIOX005A00 is an accessory that contains both 33ZCSENCO2 and 33ZCASPCO2 accessories.

**Accessories List** — The EconoMiSer X system has several field-installed accessories available to optimize performance. Refer to Table 6 for authorized parts and power exhaust descriptions.

**Table 6 —EconoMiSer® 2 Field-Installed Accessories**

DESCRIPTION	PART NUMBER
Small Cabinet Power Exhaust (208-230v/1Ph)	CRPWREXH030A01
Small Cabinet Power Exhaust (460v/3Ph)	CRPWREXH021A01
Large Cabinet Power Exhaust (208-230v/3Ph)	CRPWREXH022A01
Large Cabinet Power Exhaust (460v/3Ph)	CRPWREXH023A01
Extra Large Cabinet Power Exhaust (208-230v/3Ph)	CRPWREXH080A00
Extra Large Cabinet Power Exhaust (460v/3Ph)	CRPWREXH081A00
Return Air Dry Bulb or Enthalpy Sensor	HH57AC081
Outdoor Air Enthalpy Sensor	HH57AC081
CO <sub>2</sub> Room Sensor	33ZCSENC02 or CGCDXSEB004A00
Aspirator Box for Duct Mount CO <sub>2</sub> Sensor (4 to 20 mA)	33ZCASPC02 or CGCDXASP001A00
Space Temperature and CO <sub>2</sub> Room Sensor with Override (4 to 20 mA)	33ZCT55CO2
Space Temperature and CO <sub>2</sub> Room Sensor with Override and Set Point (4 to 20 mA)	33ZCT56CO2

**Compliance** — Economizers meet California Energy Commission Title 24-2016 prescriptive section 140.4 (damper leakage etc.), and mandatory section 120.2.i for Fault Detection and Diagnostic controls.

Economizers meet ASHRAE 90.1-2016 damper leakage requirements as stated in section 6.5.1.1.4 and Table 6.4.3.4.3, and meet 2016 Fault Detection and Diagnosis requirements in section 6.4.3.12.

Economizers meet IECC 2012 section C402.4.5.2 and, IECC 2015 sections C403.2.4.3 and C403.3.3.5 for outside air, return, and relief air damper leakage requirements, and IECC 2015 section C403.2.4.7 for Fault Detection and Diagnostic requirements.

NOTE: IECC 2015 section C403.2.4.7.1 requires differential return air sensor, which must be ordered separately.

Outside air and return air (volume) dampers are AMCA rated. Relief air dampers are also AMCA rated.

**INSTALLATION**

See Fig. 1 for component locations on the EconoMiSer X system.

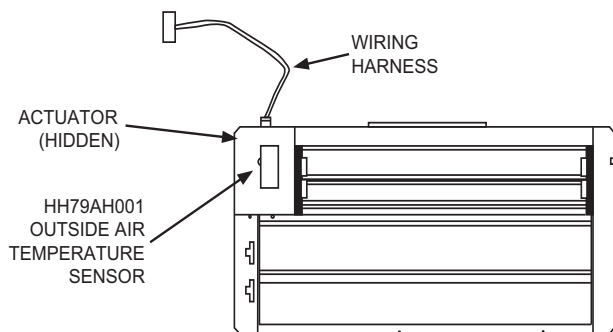

**Fig. 1 — EconoMiSer® X Component Locations (Small Economizer Shown)**

1. Turn off unit power supply(s) and install lockout tag.
2. Remove the existing unit filter access panel. Raise the panel and swing the bottom outward. The panel is now disengaged from the track and can be removed (see Fig. 2).

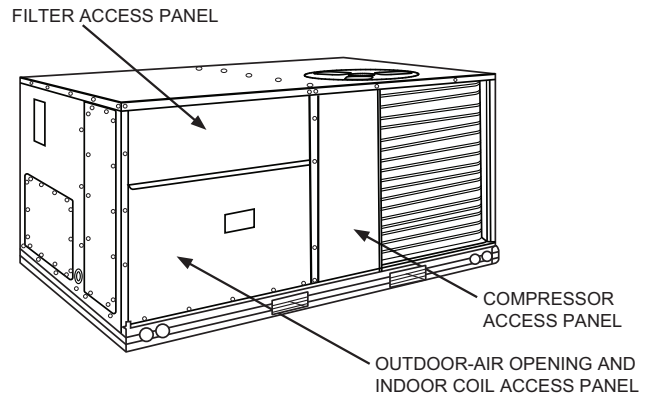
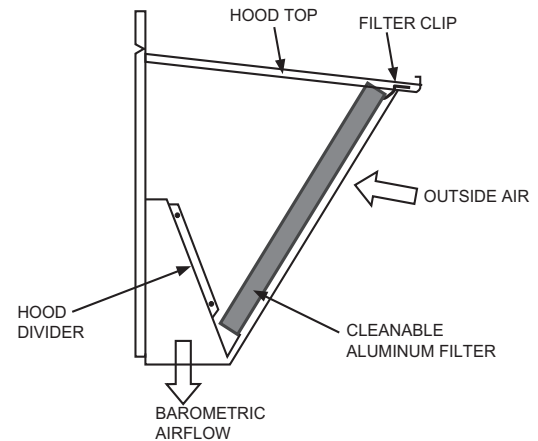

**Fig. 2 — Typical Access Panel Locations**

3. Remove the indoor coil access panel and discard (see Fig. 2).
4. The EconoMiSer X hood components are shipped with the EconoMiSer X system. Remove hood from packaging. The hood top and sides are shipped factory assembled.

NOTE: If the power exhaust accessory is to be installed on the unit, the hood shipped with the EconoMiSer X system will not be used and may be discarded. Save the aluminum filter for use in the power exhaust hood assembly.

5. Insert the hood divider between the hood sides (see Fig. 3 and 4). Secure hood divider with 2 screws (provided) on each hood side. Screws should go through the hood sides into the divider. The hood divider is also used as the bottom filter rack for the aluminum filter. On hood for extra large cabinet install filter divider (see Fig. 5).



**Fig. 3 — Fully Assembled Hood**

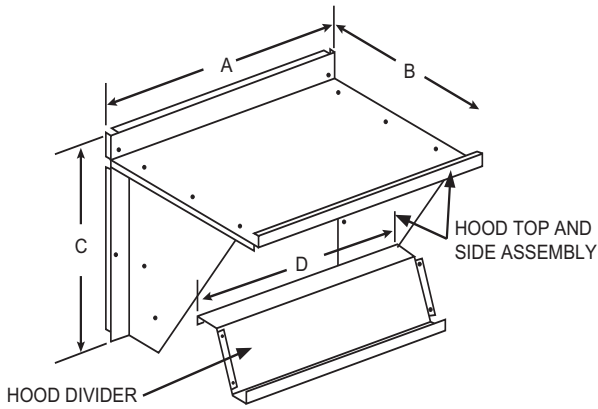

ECONOMIZER P/N	A (in.)	B (in.)	C (in.)	D (in.)	SHIP WT. (lb)
CRECOMZR067A01	30.37	17.43	19.05	29.50	55 lb
CRECOMZR069A01	40.37	22.28	24.48	36.27	80 lb
CRECOMZR071A01	52.92	27.03	33.41	46.92	98 lb

NOTE: The CRECOMZR070A01 hood has 2 aluminum filters and a hood filter divider that installs between the filters.

→ Fig. 4 — Hood Assembly

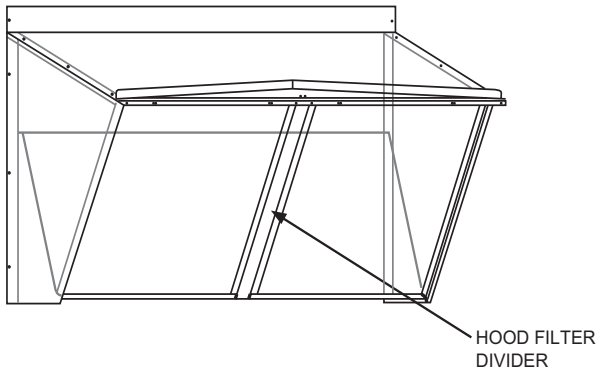

Fig. 5 — Hood for Extra Large Cabinet

6. Set the EconoMiSer X system upright.

7. Slide the EconoMiSer X assembly into the rooftop unit (see Fig. 6). On small and large cabinets be sure to engage the rear EconoMiSer X flange under the tabs in the return-air opening of the unit base (see Fig. 7).

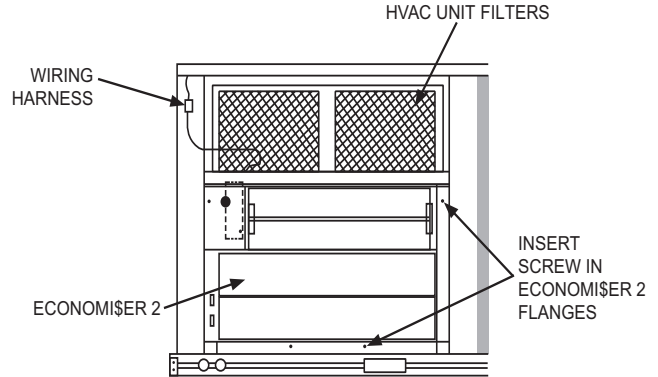

Fig. 6 — EconoMiSer® 2 Installed on HVAC Unit (Small Cabinet Economizer Shown)

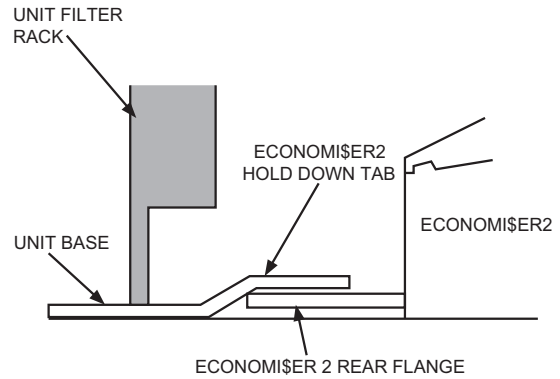
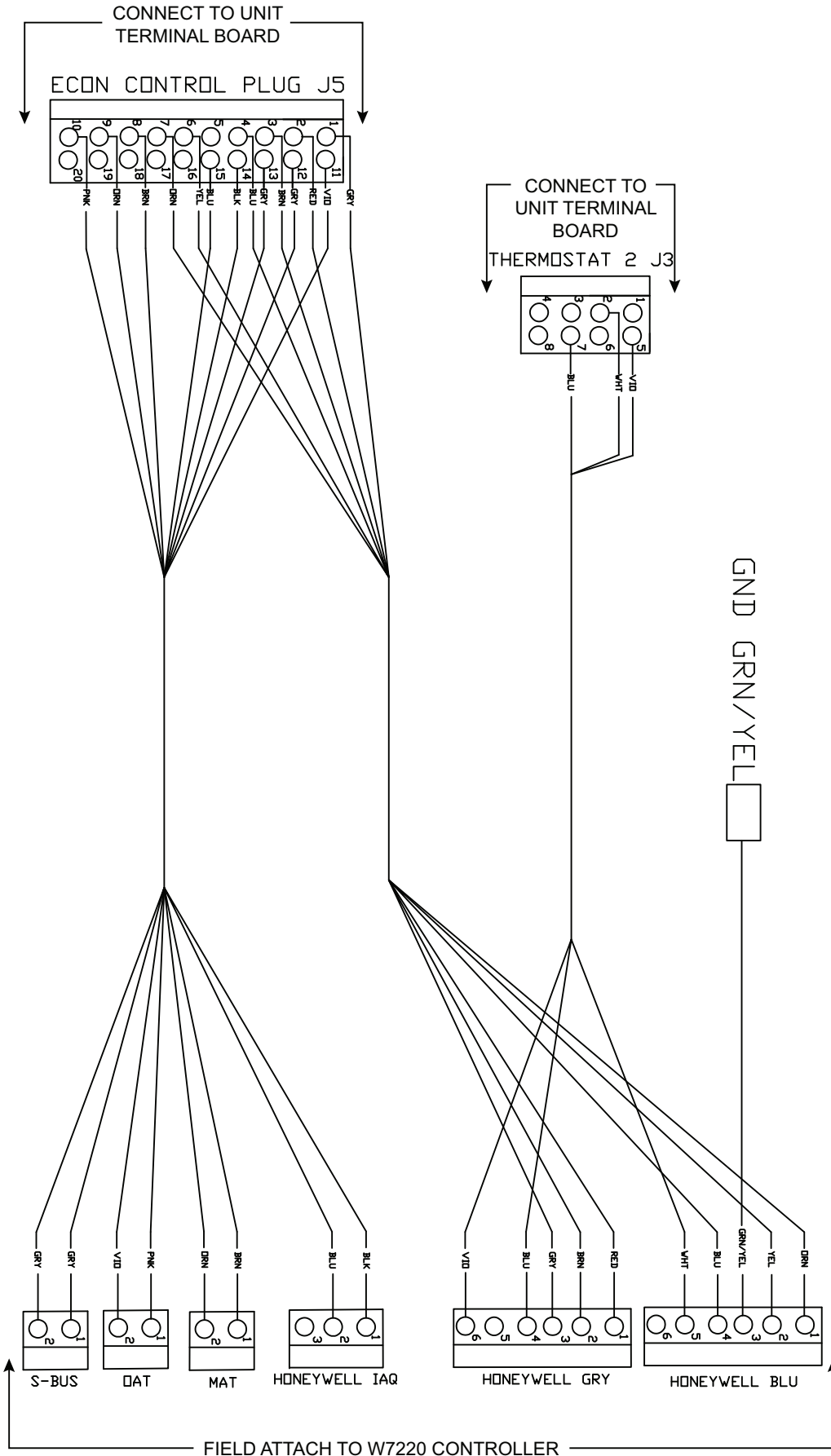

Fig. 7 — Rear EconoMiSer® 2 Flange Installation (Small and Large Cabinet)

8. Secure the EconoMiSer X system to the unit along side and bottom flanges using the screws provided.
9. Remove the tape securing the relief dampers in place.
10. Remove and save the 12-pin jumper plug from the unit wiring harness (located in the upper left corner of the unit). Insert the EconoMiSer X plug into the unit wiring harness. See Fig. 8-10 for wiring details.



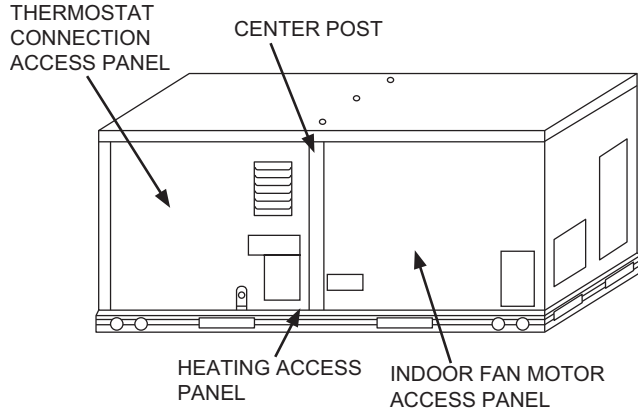



**Fig. 10 — 48LCHSRADH--A00 Harness for 3 Speed Units (48/50LC 14)  
(Provided with 3 Speed Units, Field Attached to W7220 Controller)**

NOTE: The 12-pin jumper plug should be saved for future use, in the event that the EconoMi\$er X is removed from the unit. The jumper plug is not needed as long as the EconoMi\$er X system is installed.

11. If EconoMi\$er X system will be operating under enthalpy control, replace the factory installed HH79AH001 outdoor dry bulb temperature sensor with accessory enthalpy sensor HH57AC081 (see Fig. 1).
12. Remove the indoor fan motor access panel (see Fig. 11).



**Fig. 11 — Typical Indoor Fan Motor Access Panel Locations**

13. Locate the HH79AH001 mixed (supply) air temperature sensor in the economizer hardware bag. A 2-wire SAT sensor harness with spade terminals is supplied with the sensor. Plug the harness into the top of the HH79AH001 sensor. Mount the sensor in the indoor fan section of the unit, see Fig. 12. Locate the orange and brown wires in the wire bundle in the indoor fan section. Connect these orange and brown wires to the 2-wire harness attached to the HH79AH001 sensor. Mixed air default setting is 53°F and can be adjusted from 38°F to 70°F.
14. While everything is open install and wire any other accessories and/or sensors as applicable and convenient, per their installation instructions and/or the Configuration section of the base unit book. Some accessories require that unit ducting already be installed.

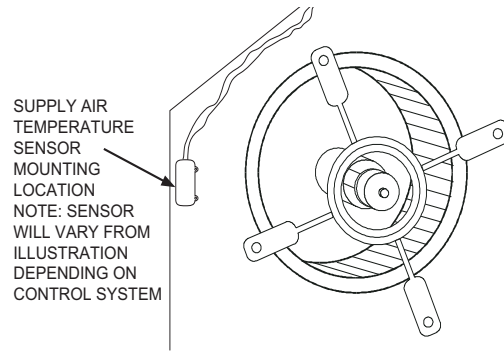

**Fig. 12 — Supply Air Sensor Placement**

NOTE: If also installing a power exhaust accessory, skip Step 15 and follow the power exhaust instructions instead.

15. Install the EconoMi\$er X hood over the EconoMi\$er X system. Use screws provided.
16. The W7220 EconoMi\$er X controller is shipped mounted to a bracket. Install the controller / bracket in the top left corner of the unit control box as shown in wiring diagram, Fig. 13 and 8. Screw in place through pre-punched holes.
17. For 1 and 2 speed units connect the plugs coming from the controller as shown in wiring diagram, Fig. 14 and 8.

NOTE: Provided harness 48TMHSRSE--A20 will be connected as shown in Fig. 13 and 8.

18. For 3 speed (48/50LC 14) units, the harness attached to the W7220 EconoMi\$er X controller must be removed, and can be discarded. Locate harness 48LCHSRADH--A00 shipped in plastic bag in the control box of unit. Attach this harness to the W7220 controller as shown in Fig 9 and 10.

NOTE: Harness 48TMHSRSE--A20 provided with economizer is not used with 3 speed (48/50LC 14) units.

19. Adjust controller settings (minimum position, outside air, etc.) per instructions detailed later in this instruction.
20. Follow all local and other applicable codes.

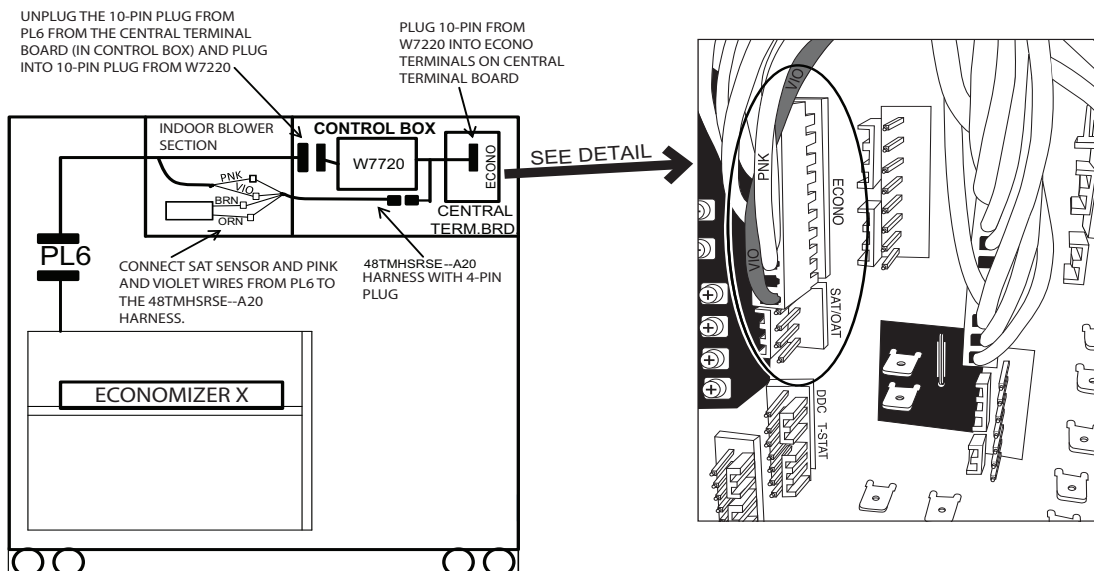

**Fig. 13 — Harness Detail**

## Wiring Instructions for 1 and 2 Speed Units

1. Install W7220 (with harnesses attached) in unit top left of control box. See Fig. 8 and 9.
2. Mount supply air temperature (SAT) sensor, with 2 wire SAT harness attached, in the indoor blower section.
3. Unplug the econo harness from PL6 with 10-pin plug shown in Fig. 13, from Central Terminal Board (CTB).
4. Attach 10-pin plug disconnected from (CTB) to 10-pin plug harness from W7220 controller.
5. Connect other 10-pin plug from W7220 controller into ECONO terminals on CTB. See Fig. 13.
6. Inside control box - connect 4-pin plug from the W7220 controller to the 4-pin 50HEHMRAE--A10 harness provided with economizer accessory.
7. Inside the control box - the brown and orange wires with male terminals from the 50HEHMRAE--A10 harness connect to the female terminals on the pink and violet wires from the PL6 harness.
8. Inside the control box – connect the pink and violet wires with female terminals on 50HEHMRAE--A10, to the pink and violet wires with male terminals from the PL6 harness.
9. Inside the indoor blower section connect the pink and violet wires from the PL6 harness to the (2) green wires leading to the SAT.

**W7220 Economizer Controller** — The economizer controller used on electro-mechanical units is a Honeywell W7220 which is to be located in the RTU base unit's control box. See Fig. 14 for button description of the W7220 controller. See the Installation Instruction for your base unit for the location of the control box access panel.

The W7220 controller provides the following:

- 2-line LCD interface screen for setup, configuration, and troubleshooting
- On-board fault detection and diagnostics
- Sensor failure loss of communications identification
- Automatic sensor detection
- Capabilities for use with multiple-speed indoor fan systems

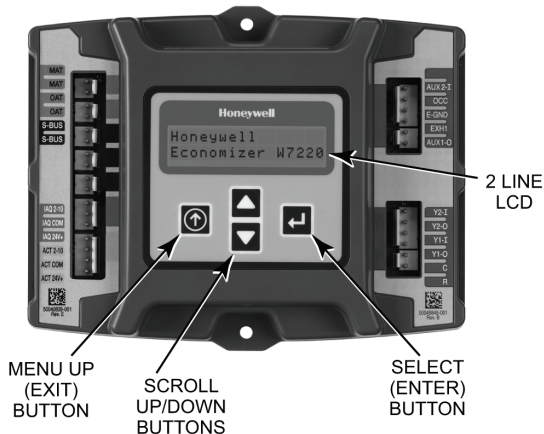

Fig. 14 — W7220 Controller

**USER INTERFACE** — The user interface consists of an LCD display and a 4-button keypad on the front of the economizer controller.

**KEYPAD** — The four navigation buttons (see Fig. 14) are used to scroll through the menus and menu items, select menu items, and to change parameter and configuration settings.

**USING THE KEYPAD WITH MENUS** — To use the keypad when working with menus:

- Press the ▲ (Up arrow) button to move to the previous menu.
- Press the ▼ (Down arrow) button to move to the next menu.
- Press the (Enter) button to display the first item in the currently displayed menu.
- Press the ⏪ (Menu Up/Exit) button to exit a menu's item and return to the list of menus.

**USING THE KEYPAD WITH SETTINGS AND PARAMETERS** — To use the keypad when working with Setpoints, System and Advanced Settings, Checkout Tests and Alarms:

1. Navigate to the desired menu.
2. Press the (Enter) button to display the first item in the currently displayed menu.
3. Use the ▲ and ▼ buttons to scroll to the desired parameter.
4. Press the (Enter) button to display the value of the currently displayed item.
5. Press the ▲ button to increase (change) the displayed parameter value.
6. Press the ▼ button to decrease (change) the displayed parameter value.

**NOTE:** When values are displayed, pressing and holding the ▲ or ▼ button causes the display to automatically increment.

7. Press the (Enter) button to accept the displayed value and store it in nonvolatile RAM.
8. “CHANGE STORED” displays.
9. Press the (Enter) button to return to the current menu parameter.
10. Press the ⏪ (Menu Up/Exit) button to return to the previous menu.

**MENU STRUCTURE** — Table 7 illustrates the complete hierarchy of menus and parameters for the EconoMiSer X system.

The menus in display order are:

- STATUS
- SETPOINTS
- SYSTEM SETUP
- ADVANCED SETUP
- CHECKOUT
- ALARMS

**IMPORTANT:** The default setting on the W7220 controller is for a “Fan Type” with 2 speeds. If your unit is 1 (single) speed, the setting under SYSTEM SETUP > FAN TYPE must be changed to 1 speed.

See Fig. 15 for wiring the W7220 controller for exhaust and fault alarm.

**WIRING W7220 FOR EXHAUST AND FAULT ALARM**

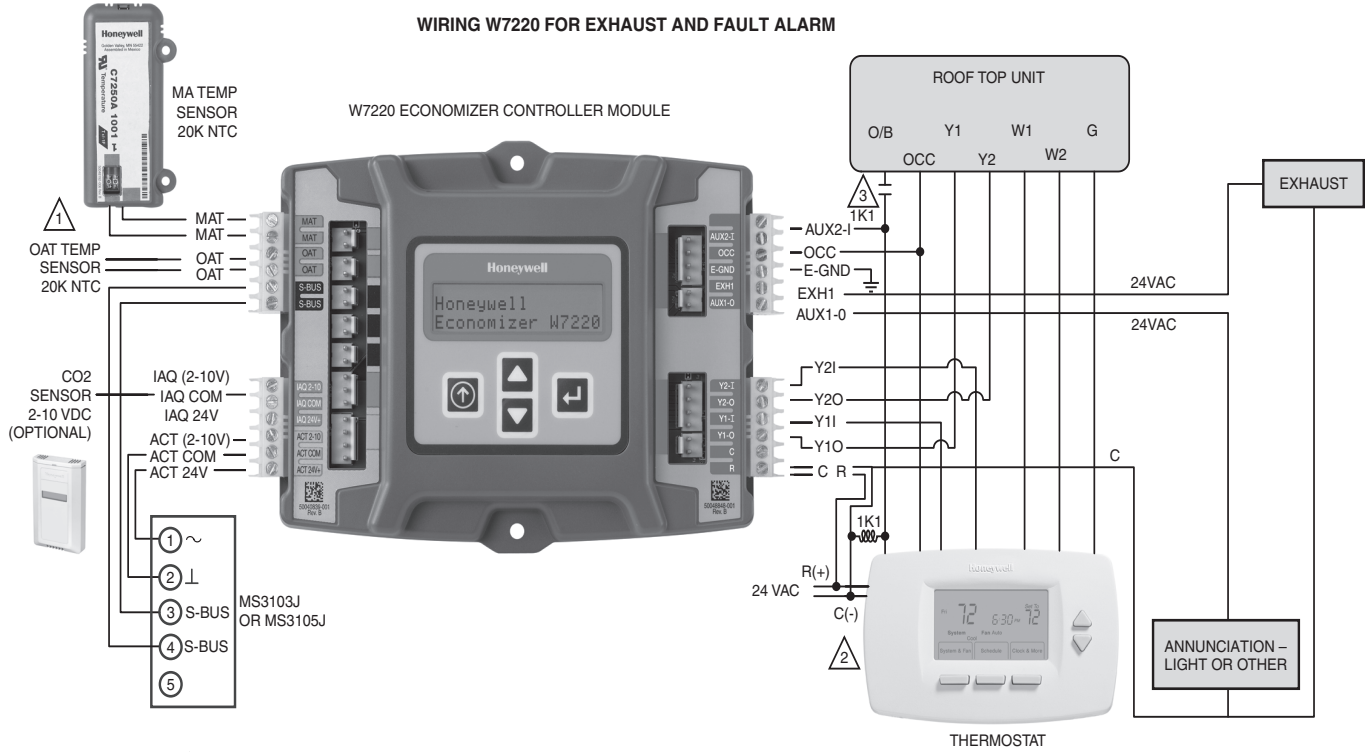

- ⚠️ 1 NOTE THAT THE 20K NTC SENSOR CAN BE MOUNTED IN THE OAT TERMINALS ONLY IN THIS CONFIGURATION.
- ⚠️ 2 WHEN USING A HEAT PUMP THERMOSTAT, THERMOSTAT TERMINALS MAY DIFFER: W1 MAY BE LABELED O OR B AND W2 MAY BE LABELED W.
- ⚠️ 3 WHEN USING A HEAT PUMP WITH DEFROST FEEDBACK, ADD AN ISOLATION RELAY BETWEEN O AND C.

**Fig. 15 — Wiring W7220 Controller for Exhaust and Fault Alarm**

**Table 7 — Menu Structure\***

MENU	PARAMETER	PARAMETER DEFAULT VALUE	PARAMETER RANGE AND INCREMENT†	NOTES
STATUS	ECONO AVAIL	NO	YES/NO	YES = economizing available; the system can use outside air for free cooling when required
	ECONOMIZING	NO	YES/NO	YES = outside air being used for 1 stage cooling
	OCCUPIED	NO	YES/NO	YES = OCC signal received from space thermostat or unitary controller YES = 24 Vac on terminal OCC. NO = 0 Vac on terminal OCC.
	HEAT PUMP	N/A**	COOL HEAT	Displays COOL or HEAT when system is set to heat pump (Non-conventional).
	COOL Y1—IN	OFF	ON/OFF	Y1—I signal from space thermostat or unitary controller for cooling stage 1. ON = 24 Vac on terminal Y1—I OFF = 0 Vac on terminal Y1—I
	COOL Y1—OUT	OFF	ON/OFF	Cool stage 1 Relay Output to stage 1 mechanical cooling (Y1—OUT terminal).
	COOL Y2—IN	OFF	ON/OFF	Y2—I signal from space thermostat our unitary controller for second stage cooling. ON = 24 Vac on terminal Y2—I OFF = 0 Vac on terminal Y2—I
	COOL Y2—OUT	OFF	ON/OFF	Cool Stage 2 Relay Output to mechanical cooling (Y2—OUT terminal)
	MA TEMP	__ . __ F	0 to 140 F	Displays value of measured mixed air from MAT sensor. Displays __ . __ F if not connected, short or out-of-range.
	DA TEMP	__ . __ F	0 to 140 F	Displays when discharge air sensor is connected and displays measured discharge temperature. Displays __ . __ F if sensor sends invalid value, if not connected, short or out-of-range.
	OA TEMP	__ . __ F	-40 to 140 F	Displays measured value of outdoor air temperature. Displays __ . __ F if sensor sends invalid value, short or out-of-range.
	OA HUM	__ %	0 to 100%	Displays measured value of outdoor humidity from OA sensor. Displays __ % if not connected short, or out-of-range.
	RA TEMP	__ . __ F	0 to 140 F	Displays measured value of return air temperature from RAT sensor. Displays __ . __ F if sensor sends invalid value, if not connected, short or out-of-range
	RA HUM	__ %	0 to 100%	Displays measured value of return air humidity from RA sensor. Displays __ % if sensor sends invalid value, if not connected, short or out-of-range
	IN CO2	___ ppm	0 TO 2000 ppm	Displays value of measured CO <sub>2</sub> from CO <sub>2</sub> sensor. Invalid if not connected, short or out-of-range.
	DCV STATUS	N/A	ON/OFF	Displays ON if above setpoint and OFF if below setpoint, and ONLY if a CO <sub>2</sub> sensor is connected.
	DAMPER OUT	2.0v	2.0 TO 10.0v	Displays voltage output to the damper actuator.
	EXH1 OUT	OFF	ON/OFF	Output of EXH1 terminal: ON = relay closed OFF = relay open
	EXH2 OUT	OFF	ON/OFF	Output of AUX terminal; displays only if AUX = EXH2.
	ERV	OFF	ON/OFF	Output of AUX terminal; displays only if AUX = ERV.
MECH COOL ON	0	0, 1, or 2	Displays stage of mechanical cooling that is active.	

See legend on page 14.

**Table 7 — Menu Structure (cont)\***

MENU	PARAMETER	PARAMETER DEFAULT VALUE	PARAMETER RANGE AND INCREMENT†	NOTES
<b>SETPOINTS</b>	MAT SET	53 F	38 to 65 F; increment by 1	Setpoint determines where the economizer will modulate the OA damper to maintain the mixed air temperature.
	LOW T LOCK	32 F	-45 to 80 F; increment by 1	Setpoint determines outdoor temperature when the mechanical cooling cannot be turned on. Commonly referred to as the Compressor lockout.
	DRYBLB SET	63 F	48 to 80 F; increment by 1	Setpoint determines where the economizer will assume outdoor air temperature is good for free cooling; e.g.; at 63 F unit will economize at 62°F and below and not economize at 64°F and above. There is a 2°F deadband.
	ENTH CURVE	ES3	ES1,ES2,ES3,ES4, or ES5	Enthalpy boundary “curves” for economizing using single enthalpy.
	DCV SET	1100 ppm	500 to 2000 ppm; increment by 100	Displays only if CO <sub>2</sub> sensor is connected. Setpoint for Demand Control Ventilation of space. Above the setpoint, the OA dampers will modulate open to bring in additional OA to maintain a space ppm level below the setpoint.
	MIN POS	4.4 V	2 to 10 Vdc	Displays ONLY if a CO <sub>2</sub> sensor is NOT connected
	VENTMAX With 2-speed fan units VENTMAX L (low speed fan) and VENTMAX H (high speed fan) settings are required	4.4 V	2 to 10 Vdc or 100 to 9990 cfm; increment by 10	Displays only if a CO <sub>2</sub> sensor is connected. Used for Vbz (ventilation max cfm) setpoint. Displays 2 to 10 V if <3 sensors (RA,OA, and MA). In AUTO mode dampers controlled by cfm.
	VENTMAX L	6 V	N/A	N/A
	VENTMAX H	4.4 V	N/A	N/A
	VENTMIN With 2-speed fan units VENTMIN L (low speed fan) and VENTMIN H (high speed fan) set	2.8 V	2 to 10 Vdc or 100 to 9990 cfm increment by 10	Displays only if a CO <sub>2</sub> sensor is connected. Used for Ba (ventilation min cfm) setpoint. Displays 2 to 10 V if <3 sensors (RA, OA, and MA). Va is only set if DCV is used. This is the ventilation for less than maximum occupancy of the space. In AUTO mode dampers controlled by CFM.
	VENTMIN L	3.7 V	N/A	N/A
	VENTMIN H	2.8 V	N/A	N/A
	ERV OAT SP	32 F	0 to 50 F; increment by 1	Only when AUX1 O = ERV
	EXH1 SET With 2-speed fan units Exh1 L (low speed fan) and Exh1 H (high speed fan) settings are required	50%	0 to 100%;increment by 1	Setpoint for OA damper position when exhaust fan 1 is powered by the economizer.
	Exh1 L	65%	N/A	N/A
	Exh1 H	50%	N/A	N/A
	EXH2 SET With 2-speed fan units Exh2 L (low speed fan) and Exh2 H (high speed fan) settings are required	75%	0 to 100%; increment by 1	Setpoint for OA damper position when exhaust fan 2 is powered by the economizer. Only used when AUX is set to EXH2.
Exh2 L	80%	N/A	N/A	
Exh2 H	75%	N/A	N/A	
<b>SYSTEM SETUP</b>	INSTALL	01/01/10	N/A	Display order = MM/DD/YY Setting order = DD, MM, then YY.
	UNITS DEG	F	F or C	Sets economizer controller in degrees Fahrenheit or Celsius
	EQUIPMENT	CONV	Conventional or HP	CONV = conventional; HP O/B = Enable Heat Pump mode. Use AUX2 I for Heat Pump input from thermostat or controller.
	AUX2 I	W	SD/W or HP(O)/HP(B)	In CONV mode: SD + Enables configuration of shutdown (default); W = Informs controller that system is in heating mode. In HP O/B mode: HP(O) = energize heat pump on Cool (default); HP(B) = energize heat pump on heat.
	FAN TYPE	2 speed	1 speed/2 speed	Sets the economizer controller for operation of 1 speed or 2 speed supply fan. (Note: for 3 speed units (48/50LC 14), setpoint is a 2 speed.)
	FAN CFM	5000cfm	100 to 15000 cfm; increment by 100	This is the capacity of the RTU Open Controller. The value is found in the Project Submittal documents for the specific RTU.
	AUX OUT	NONE	NONE ERV EXH2 SYS	<ul style="list-style-type: none"> <li>• NONE = not configured (output is not used)</li> <li>• ERV = Energy Recovery Ventilator</li> <li>• EXH2 = second damper position relay closure for second exhaust fan</li> <li>• SYS = use output as an alarm signal</li> </ul>
	OCC	INPUT	INPUT or ALWAYS	When using a setback thermostat with occupancy out (24 vac), the 24 vac is input “INPUT” to the OCC terminal. If no occupancy output from the thermostat then change program to “ALWAYS” OR add a jumper from terminal R to OCC terminal.
FACTORY DEFAULT	NO	NO or YES	Resets all set points to factory defaults when set to YES. LCD will briefly flash YES and change to NO but all parameters will change to the factory default values.	

See legend on page 14.

**Table 7 — Menu Structure (cont)\***

MENU	PARAMETER	PARAMETER DEFAULT VALUE	PARAMETER RANGE AND INCREMENT†	NOTES	
ADVANCED SETUP	MA LO SET	45 F	35 to 55 F; incremented by 10	Temperature to achieve Freeze Protection (close damper and alarm if temperature falls below setup value).	
	FREEZE POS	CLO	CLO or MIN	Damper position when freeze protection is active (closed or MIN POS).	
	CO2 ZERO	0 ppm	0 to 500 ppm; increment by 10	CO <sub>2</sub> ppm level to match CO <sub>2</sub> sensor start level.	
	CO2 SPAN	2000 ppm	1000 to 3000 ppm; increment by 10	CO <sub>2</sub> ppm span to match CO <sub>2</sub> sensor.	
	STG3 DLY	2.0 h	0 min, 5 min, 15 min, then 15 min intervals. Up to 4 h or OFF	Delay after stage 2 cool has been active. Turns on second stage of cooling when economizer is first stage and mechanical cooling is second stage. Allows three stages of cooling, 1 economizer and 2 mechanical. OFF = no Stage 3 cooling	
	SD DMPR POS	CLO	CLO or OPN	Indicates shutdown signal from space thermostat or unitary controller. When controller receives 24 Vac input on the SD terminal in conventional mode, the OA damper will open if programmed for OPN and OA damper will close if programmed for CLO. All other controls, e.g., fans, etc. will shut off.	
	DCVCAL ENA	MAN	MAN (manual) AUTO	Turns on the DCV automatic control of the dampers. Resets ventilation based on the RA, OA, and MA sensor conditions. Requires all 3 RA, OA, and MA sensors.	
	MAT T CAL	0.0 F	±2.5 F	Allows for the operator to adjust for an out of calibration temperature sensor.	
	OA T CAL	0.0 F	±2.5 F	Allows for the operator to adjust for an out of calibration temperature sensor.	
	OA H CAL	0% RH	±10% RH	Allows for operator to adjust for an out of calibration humidity sensor.	
	RA T CAL	0.0 F	±2.5 F	Allows for the operator to adjust for an out of calibration temperature sensor.	
	RA H CAL	0% RH	±10% RH	Allows for operator to adjust for an out of calibration humidity sensor.	
	DA T CA;	0.0 F	±2.5 F	Allows for the operator to adjust for an out of calibration temperature sensor.	
CHECKOUT	DAMPER VMIN-HS	N/A	N/A	Positions damper to VMIN position	
	DAMPER VMAX-HS	N/A	N/A	Positions damper to VMAX position	
	DAMPER OPEN	N/A	N/A	Position damper to the full open position. Exhaust fan contacts enable during the DAMPER OPEN test. Make sure to pause this mode to allow exhaust contacts to energize due to the delay in the system.	
	DAMPER CLOSE	N/A	N/A	Positions damper to the fully closed position	
	CONNECT Y1-O	N/A	N/A	Closes the Y1—O relay (Y1—O)	
	CONNECT Y2-O	N/A	N/A	Closes the Y2—O relay (Y2—O)	
ALARMS	CONNECT AUX	N/A	N/A	Energizes the AUX output. If Aux setting is: <ul style="list-style-type: none"> <li>• NONE= not action taken</li> <li>• ERV = 24 Vac out. Turns on or signals an ERV that the conditions are not good for economizing but are for ERV operation††</li> <li>• SYS = 24 Vac out. Issues a system alarm</li> </ul>	
	Alarms display only when they are active. The menu title "ALARMS(#)" includes the number of active alarms in parenthesis ( ). When using SYLK bus sensors, "SYLK" will appear on the screen, and when using 20k OA temperature sensors, "SENS T" will appear on the screen				
	MAT SENS ERR	N/A	N/A	Mixed air sensor has failed or become disconnected - check wiring then replace sensor if the alarm continues.	
	CO2 SENS ERR	N/A	N/A	CO <sub>2</sub> sensor has failed, gone out of range or become disconnected - check wiring then replace sensor if the alarm continues.	
	OA SYLK T ERR	N/A	N/A	Outdoor air enthalpy sensor has failed or become disconnected - check wiring then replace sensor if the alarm continues.	
	OA SYLK H ERR	N/A	N/A	Outdoor air enthalpy sensor has failed or become disconnected - check wiring then replace sensor if the alarm continues.	
	RA SYLK T ERR	N/A	N/A	Return air enthalpy sensor has failed or become disconnected - check wiring then replace sensor if the alarm continues.	
	RA SYLK H ERR	N/A	N/A	Return air enthalpy sensor has failed or become disconnected - check wiring then replace sensor if the alarm continues.	
	DA SYLK T ERR	N/A	N/A	Discharge air sensor has failed or become disconnected - check wiring then replace sensor if the alarm continues	
	OA SENS T ERR	N/A	N/A	Outdoor air temperature sensor has failed or become disconnected - check wiring then replace if the alarm continues.	
	ACT ERROR	N/A	N/A	Actuator has failed or become disconnected - check for stall, over voltage, under-voltage and actuator count. Replace actuator if damper is movable and supply voltage is between 21.6 V and 26.4 V. Check actuator count on STATUS menu	
	FREEZE ALARM	N/A	N/A	Check if outdoor temperature is below the LOW Temp Lock-out on setpoint menu. Check if Mixed air temperature on STATUS menu is below the Lo Setpoint on Advanced menu. When conditions are back in normal range then the alarm will go away.	
	SHUTDOWN ACTIVE	N/A	N/A	AUX2 IN is programmed for SHUTDOWN and 24 V has been applied to AUX 2IN terminal.	

See legend on page 14.

**Table 7 — Menu Structure (cont)\***

MENU	PARAMETER	PARAMETER DEFAULT VALUE	PARAMETER RANGE AND INCREMENT†	NOTES
ALARMS (cont)	DMP CAL RUNNING	N/A	N/A	If DCV Auto enable has been programmed, when the Jade is completing a calibration on the dampers, this alarm will display. Wait until the calibration is completed and the alarm will go away. Must have OA, MA and RA sensors for DCV calibration; set up in the Advanced setup menu.
	DA SENS ALM	N/A	N/A	Discharge air temperature is out of the range set in the ADVANCED SETUP Menu. Check the temperature of the discharge air.
	SYS ALARM	N/A	N/A	When AUX1-0 is set to SYS and there is any alarm (e.g., failed sensors, etc.), the AUX1-0 terminal has 24 Vac out.
	ACT UNDER V	N/A	N/A	Voltage received by Actuator is above expected range.
	ACT OVER V	N/A	N/A	Voltage received by Actuator is below expected range.
	ACT STALLED	N/A	N/A	Actuator stopped before achieving commanded position.

LEGEND

- LCD** — Liquid Crystal Display
- MAT** — Mixed Air Temperature
- OAT** — Outdoor Air Temperature
- OCC** — Occupied
- RAT** — Return Air Temperature
- RTU** — Rooftop Unit

\* Table 7 illustrates the complete hierarchy. The menu parameters may be different depending on the configuration. For example, if there is no DCV (CO<sub>2</sub>) sensor, then none of the DCV parameters appear.

† When values are displayed, pressing and holding the ▲ or ▼ button causes the display to automatically increment.

\*\* N/A = Not Applicable.

†† ERV Operation: When in cooling mode AND the conditions are NOT OK for economizing - the ERV terminal will be energized. In the Heating mode, the ERV terminal will be energized when the OA is below the ERV OAT setpoint in the setpoint menu.

CHECKOUT TESTS — Use the Checkout menu to test the damper operation and any configured outputs. Only items that are configured are shown in the Checkout menu.

NOTE: See User Interface for information about menu navigation and use of the keypad.

1. To perform a Checkout test:
2. Scroll to the desired test in the Checkout menu using the ▲ and ▼ buttons.
3. Press the button to select the item.
4. RUN? appears.
5. Press the button to start the test.
6. The unit pauses and then displays IN PROGRESS.
7. When the test is complete, DONE appears.
8. When all desired parameters have been tested, press the ▲ (Menu up) button to end the test.

Checkout test can be performed at any time during the operation of the system as a test that the system is operable.

**⚠ CAUTION**

Failure to follow this caution may result in damage to equipment. Be sure to allow enough time for compressor startup and shutdown between checkout tests so that the compressors do not short-cycle.

**W7220 Economizer Module Wiring** — Use Fig. 16 and Tables 8 and 9 to locate the wiring terminals for the economizer module.

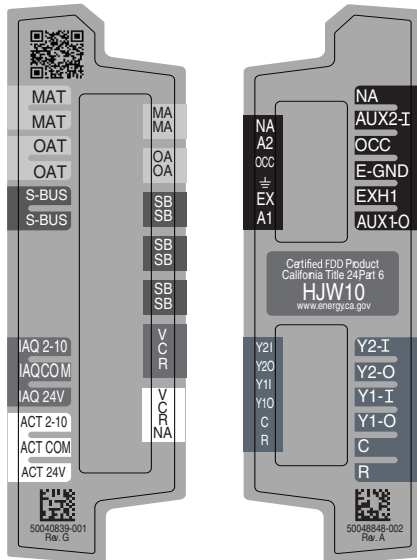

**Fig. 16 — W7220 Economizer Module Terminal Connection Labels**

NOTE: The four terminal blocks are removable. Terminal blocks can be slid out, wired, and then slid back into place.

**Table 8 — Economizer Module - Left Hand Terminal Blocks**

LABEL	TYPE	DESCRIPTION
<b>Top Left Terminal Block</b>		
<b>MAT</b> MAT	20k NTC and COM	Mixed Air Temperature Sensor (Polarity Insensitive Connection)
<b>OAT</b> OAT	20k NTC and COM	Outdoor Air Temperature Sensor (Polarity Insensitive Connection)
<b>S-BUS</b> S-BUS	S-BUS (Sylk Bus)	Enthalpy Control Sensor (Polarity Insensitive Connection)
<b>Bottom Left Terminal Block</b>		
<b>IAQ 2-10</b>	2-10 vdc	Air Quality Sensor Input (e.g. CO <sub>2</sub> sensor)
<b>IAQ COM</b>	COM	Air Quality Sensor Common
<b>IAQ 24V</b>	24 vac	Air Quality Sensor 24 vac Source
<b>ACT 2-10</b>	2-10 vdc	Damper Actuator Output (2-10 vdc)
<b>ACT COM</b>	COM	Damper Actuator Output Common
<b>ACT 24v</b>	24 vac	Damper Actuator 24 vac Source

**Table 9 — Economizer Module - Right Hand Terminal Blocks**

LABEL	TYPE	DESCRIPTION
<b>Top Right Terminal Blocks</b>		
<b>AUX2 I</b>	24 vac IN	The first terminal is not used.
<b>OCC</b>	24 vac IN	Shut Down (SD) or HEAT (W) Conventional only and Heat Pump Changeover (O-B) in Heat Pump mode.
<b>E-GND</b>	E-GND	Occupied/Unoccupied Input
<b>EXH1</b>	24 vac OUT	Exhaust Fan 1 Output
<b>AUX1 O</b>	24 vac OUT	Programmable: Exhaust fan 2 output or ERV or System alarm output
<b>Bottom Right Terminal Blocks</b>		
<b>Y2-I</b>	24 vac IN	Y2 in - Cooling Stage 2 Input from space thermostat
<b>Y2-O</b>	24 vac OUT	Y2 out - Cooling Stage 2 Output to stage 2 mechanical cooling
<b>Y1-I</b>	24 vac IN	Y1 in - Cooling Stage 2 Input from space thermostat
<b>Y1-O</b>	24 vac OUT	Y1 out - Cooling Stage 2 Output to stage 2 mechanical cooling
<b>C</b>	COM	24 vac Common
<b>R</b>	24 vac	24 vac Power (hot)

TIME-OUT AND SCREEN SAVER — When no buttons have been pressed for 10 minutes, the LCD displays a screen saver, which cycles through the Status items. Each status item displays in turn and cycles to the next item after 5 seconds.

HH79AH001 DRY BULB SENSOR — Economizers are shipped standard with an HH79AH001 outside air dry bulb sensor (see Fig. 17). System default setting (high temp limit) is 63°F, and has a range of 48°F to 80°F. Sensor is factory installed on the economizer.

NOTE: A second HH79AH001 sensor is provided for mixed air temperature.



**Fig. 17 — HH79AH001 Dry Bulb and Mixed Air Sensor**

NOTE: California high temperature setting requirements by region are shown in Table 10.

**Table 10 — California Title 24 Regional High Limit Dry Bulb Temperature Settings**

DEVICE TYPE*	CLIMATE ZONES	REQUIRED HIGH LIMIT (ECONOMIZER OFF WHEN):
		DESCRIPTION
FIXED DRY BULB	1, 3, 5, 11-16	OAT exceeds 75°F
	2, 4, 10	OAT exceeds 73°F
	6, 8, 9	OAT exceeds 71°F
	7	OAT exceeds 69°F
DIFFERENTIAL DRY BULB	1, 3, 5, 11-16	OAT exceeds RA Temp.
	2, 4, 10	OAT exceeds -2°F
	6, 8, 9	OAT exceeds -4°F
	7	OAT exceeds -4°F
FIXED ENTHALPY† + FIXED DRY BULB	ALL	OAT exceeds 28 Btu/lb of dry air or OAT exceeds 75°F

\* Only the high limit control devices listed are allowed to be used and at the setpoints listed. Others such as Dew Point, Fixed Enthalpy, Electronic Enthalpy, and Differential Enthalpy Controls, may not be used in any climate zone for compliance with Section 140.4(e)1 unless approval for use is provided by the Energy Commission Executive Director.

† At altitudes substantially different than sea level, the Fixed Enthalpy limit value shall be set to the enthalpy value at 75°F and 50% relative humidity. As an example, at approximately 6,000 foot elevation, the fixed enthalpy limit is approximately 30.7 Btu/lb.

**ENTHALPY SETTINGS (ENTHALPY OPTIONAL) —**

If installing the optional HH57AC081 enthalpy sensor. The HH79AH001 dry bulb outside air sensor must first be

removed. Wire enthalpy to S-BUS connections on W7220 controller through (2) gray wires.

When the OA temperature, enthalpy and dew point are below the respective setpoints, the Outdoor Air can be used for economizing. Figure 18 shows the new single enthalpy boundaries in the W7220. There are 5 boundaries (setpoints ES1 thru ES5), which are defined by dry bulb temperature, enthalpy and dew point.

Refer to Table 11 for ENTH CURVE setpoint values.

To use enthalpy the W7220 must have a HH57AC081 enthalpy control sensor for OA. The W7220 calculates the enthalpy and dewpoint using the OA temperature and humidity input from the OA sensor. When the OA temperature, OA humidity and OA dew point are all below the selected boundary, the economizer sets the economizing mode to YES, economizing is available.

When all of the OA conditions are above the selected boundary, the conditions are not good to economize and the mode is set to NO.

If using OA enthalpy sensor option, remove and discard the dry bulb sensor shipped with the economizer. System default setting is ES3 enthalpy curve.

See Table 10 for California Title 24 high limit dry bulb temperature settings.

Figure 18 shows the 5 current boundaries. There is also a high limit boundary for differential enthalpy. The high limit boundary is ES1 when there are no stages of mechanical cooling energized and HL (high limit) when a compressor stage is energized.

Table 11 provided the values for each boundary limit.

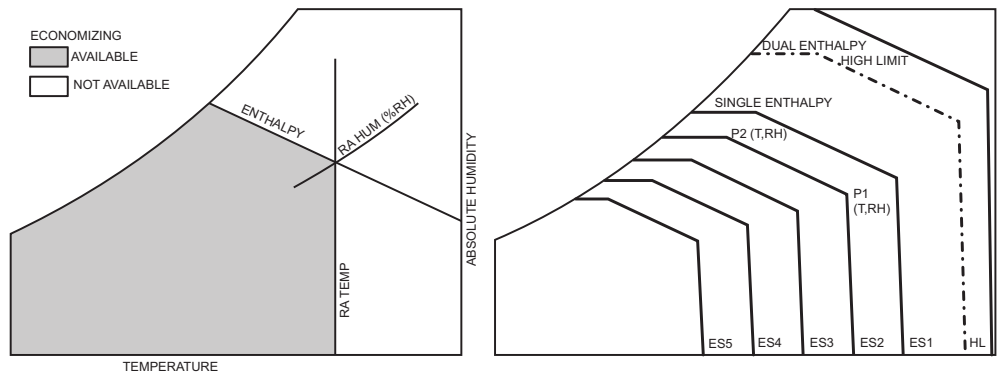

**Fig. 18 — Single Enthalpy Curve Boundaries**

**Table 11 — Single Enthalpy and Dual Enthalpy High Limit Curves**

ENTHALPY CURVE	TEMP. DRY BULB (F)	TEMP. DEWPOINT (F)	ENTHALPY (btu/lb/da)	POINT P1		POINT P2	
				TEMP. (F)	HUMIDITY (%RH)	TEMP. (F)	HUMIDITY (%RH)
ES1	80	60	28.0	80	36.8	66.3	80.1
ES2	75	57	26.0	75	39.6	63.3	80.0
ES3	70	54	24.0	70	42.3	59.7	81.4
ES4	65	51	22.0	65	44.8	55.7	84.2
ES5	60	48	20.0	60	46.9	51.3	88.5
HL	86	66	32.4	86	38.9	72.4	80.3

**ENTHALPY CONTROL SENSOR CONFIGURATION** — The optional enthalpy control sensor (Part Number: HH57AC081) communicates with the W7220 economizer controller on the two-wire communications bus and can either be wired using a two pin header or using a side connector. The HH57AC081 sensor can be used as a single outside air enthalpy, a differential return enthalpy, or a differential return temperature sensor depending on DIP-switch setting.

Use Fig. 19 and Table 12 to locate the wiring terminals for each Enthalpy Control sensor.

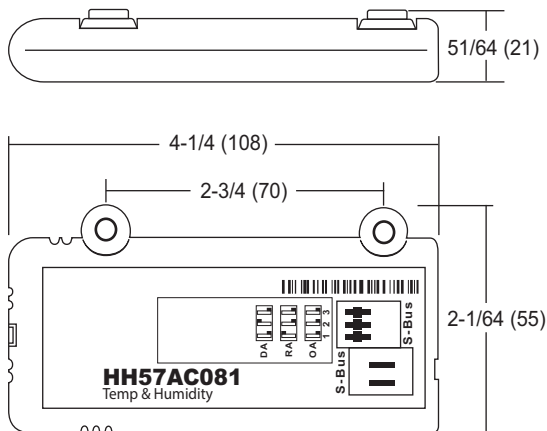

**Fig. 19 — HH57AC081 Sensor (Used as OA Enthalpy, Return Air Dry Bulb, or Return Air Enthalpy)**

**Table 12 — HH57AC081 Sensor Wiring Terminations**

TERMINAL		TYPE	DESCRIPTION
NUMBER	LABEL		
1	S-BUS	S-BUS	S-BUS Communications (Enthalpy Control Sensor Bus)
2	S-BUS	S-BUS	S-BUS Communications (Enthalpy Control Sensor Bus)

Use Fig. 19 and Table 13 to set the DIP switches for the desired use of the sensor.

**Table 13 — HH57AC081 Sensor DIP Switch**

USE	DIP SWITCH POSITIONS FOR SWITCHES 1, 2, AND 3		
	1	2	3
DA	OFF	ON	OFF
RA	ON	OFF	OFF
OA	OFF	OFF	OFF

**LEGEND**

- DA — Discharge Air or Supply Air
- OA — Return Air
- RA — Outside Air

**Table 14 — Damper Position Control, 2-Speed Fan Motor, Economizer Cooling Not Available**

INPUT	VOLTAGE				
OCC	0-V	24-V	24-V	24-V	24-V
Y1	0-V	0-V	24-V	24-V	0-V
Y2	0-V	0-V	0-V	24-V	0-V
W1	0-V	0-V	0-V	0-V	24-V
<b>SUPPLY FAN MOTOR SPEED</b>					
	OFF	LOW	LOW	HIGH	HIGH
<b>DAMPER POSITION</b>					
No CO <sub>2</sub> Sensor	CLOSED	MIN. POS.	MIN. POS.	MIN. POS.	MIN. POS.
W/ CO <sub>2</sub> Sensor	CLOSED	FROM VENTMIN L TO VENTMAX L	FROM VENTMIN L TO VENTMAX L	FROM VENTMIN H TO VENTMAX H	FROM VENTMIN H TO VENTMAX H

If using differential (return) enthalpy or temperature option, see Table 10 for California Title 24 setting requirements by region.

**START-UP**

**Cooling, Unit with EconoMiSer® X** — For Occupied mode operation of EconoMiSer X, there must be a 24-v signal at terminals R and OCC (provided through PL6-3 from the unit's IFC coil). Removing the signal at OCC places the EconoMiSer X control in Unoccupied mode. See Table 14 for Damper Position Control.

During Occupied mode operation, indoor fan operation will be accompanied by economizer dampers moving to Minimum Position setpoint for ventilation. If indoor fan is off, dampers will close. During Unoccupied mode operation, dampers will remain closed unless a Cooling (by free cooling) or DCV demand is received.

When free cooling using outside air is not available, the unit cooling sequence will be controlled directly by the space thermostat. Outside air damper position will be closed or Minimum Position as determined by Occupancy mode and fan signal.

When free cooling is available as determined by the appropriate changeover command (dry bulb, outdoor enthalpy, differential dry bulb or differential enthalpy), a call for cooling (Y1 closes at the thermostat) will cause the economizer control to modulate the dampers open and closed to maintain the unit supply air temperature. Default supply temperature is 53°F, with a range of 38°F to 70°F. Compressor will not run.

Should 100% outside air not be capable of satisfying the space temperature, space temperature will rise until Y2 is closed. The economizer control will call for compressor operation. Dampers will modulate to maintain SAT at set point concurrent with Compressor 1 operation. The "Low T Temp" setting (default 32°F) will lock out compressor operation.

When space temperature demand is satisfied (thermostat Y1 opens), the dampers will return to Minimum Damper position if indoor fan is running or fully closed if fan is off.

If accessory power exhaust is installed, the power exhaust fan motors will be energized by the economizer control as the dampers open above the EXH1 SET setpoint and will be energized as the dampers close below the EXH1 SET setpoint.

Damper movement from full closed to full open (or vice versa) will take between 1 1/2 and 2 1/2 minutes.

**Heating with EconoMiSer® X** — During Occupied mode operation, indoor fan operation will be accompanied by economizer dampers moving to Minimum Position setpoint for ventilation. If indoor fan is off, dampers will close. During Unoccupied mode operation, dampers will remain closed unless a DCV demand is received.

When the room temperature calls for heat (W1 closes), the heating controls are energized.

**Demand Controlled Ventilation** — If a field-installed CO<sub>2</sub> sensor is connected to the EconoMiSer X control, a demand controlled ventilation strategy will operate automatically. As the CO<sub>2</sub> level in the space increases above the setpoint (on the EconoMiSer X controller), the minimum position of the dampers will be increased proportionally, until the Maximum Ventilation setting is reached. As the space CO<sub>2</sub> level decreases because of the increase in fresh air, the outdoor damper will follow the higher demand condition from the DCV mode or from the free cooling mode.

DCV operation is available in Occupied and Unoccupied periods with EconoMiSer X system. However, a control modification will be required on the units to implement the Unoccupied period function.

## TROUBLESHOOTING

For a list of common operating issues and concerns see Table 15.

Figure 20 shows Barometric Relief Flow Capacity and Fig. 21 shows Return Air Pressure Drop, for adjusting these settings to meet building ventilation requirements see the base unit installation manual.

**Power Loss (Outage or Brownout)** — All setpoints and advanced settings are restored after any power loss or interruption, as all settings are stored in the economizer controller's non-volatile flash memory.

NOTE: If power goes below 18 Vac, the W7220 module assumes a power loss and the 5-minute power up delay will become functional when power returns above 18 vac.

**Alarms** — The economizer module provides alarm messages that display on the 2-line LCD.

NOTE: Upon power up, the module waits several seconds before checking for alarms. This allows time for all the configured devices (e.g. sensors, actuator) to become operational.

If one or more alarms are present and there has been no keypad activity for at least 5 minutes, the Alarms menu displays and cycles through the active alarms.

The Alarms menus can be navigated at any time. See Table 7 for the Alarms menu.

**Clearing Alarms** — Once the alarm has been identified and the cause has been removed (e.g. replaced faulty sensor). The can be cleared from the display.

To clear an alarm, perform the following:

1. Navigate to the desired alarm.
2. Press the button.
3. ERASE? displays.
4. Press the button.
5. ALARM ERASED displays.
6. Press the  (Menu Up/Exit) button to complete the action and return to the previous menu.

NOTE: If the alarm still exists after you clear it, it is redisplayed within 5 seconds.

**Table 15 — Operating Issues and Concerns**

ISSUE OR CONCERN	POSSIBLE CAUSE AND REMEDY
My outdoor temperature reading on the STATUS menu is not accurate	Check the sensor wiring: <ul style="list-style-type: none"> <li>• Enthalpy sensors are to be wired to the S-Bus terminals.</li> <li>• Temperature sensors are to be wired to the OAT and MAT terminals.</li> </ul>
If my enthalpy sensor drifts in accuracy over time, can I recalibrate it?	The sensor is not able to be re-calibrated in the field. However there is a menu item under the ADVANCED menu where you are able to input a limited off set in temperature and humidity for each sensor you have connected to the economizer.
Can I go back to factory defaults and start over?	Under the SYSTEM SETUP menu you can change the setpoints to the factory defaults.
Will I be able to see the LCD screen when it is in the unit?	The LCD screen has a backlight that is always illuminated.
What is a good setpoint for the Mixed Air Temperature (MAT)?	The mixed air temperature is the temperature of air that you want to supply to the space. In a commercial building, this is between 50 to 55°F (10 to 13°C). The mixed air is the mixing of the return air and the outdoor air.
I am using enthalpy sensors. Why did the control ask me to input a dry bulb changeover temperature?	In the even the humidity sensor in the enthalpy sensors fails, the backup algorithm in the control is to default to the temperature sensor in the enthalpy sensor.
In checkout, the outdoor damper closes when I command it to open.	Check the actuator linkage or rotation. In the CHECKOUT mode, the outdoor damper should drive open or closed with the return air damper having the opposite effect.
How do I set my minimum position?	The minimum position is set using the VENTMIN and VENTMAX setup in the SETPOINTS menu. VENTMIN is the minimum ventilation required when using an occupancy sensor and VENTMAX is the minimum ventilation when not using an occupancy sensor for Demand Controlled Ventilation. The VENTMAX position is set the same as with the potentiometer on the analog economizers and is the output voltage to the damper actuator. The range is 2 Vdc closed OA damper and 10 Vdc open OA damper.
What if my damper does not go completely closed in the checkout operation?	Check the damper linkage or hub to make sure the damper is able to close completely.
How do I set the OCC?	There are two settings for the OCC setting, INPUT and ALWAYS. INPUT is from the space thermostat, if it has an occupancy output. ALWAYS is the unit in the occupied mode, if the economizer is powered (fan on).
Does the economizer save my program values if the unit loses power?	Yes, once the changes are stored in the controller they will be stored until they are changed by the operator.
If the unit is left in checkout, how long will the unit stay in checkout mode without input?	The unit will remain in checkout for 10 minutes, then return to normal operation.

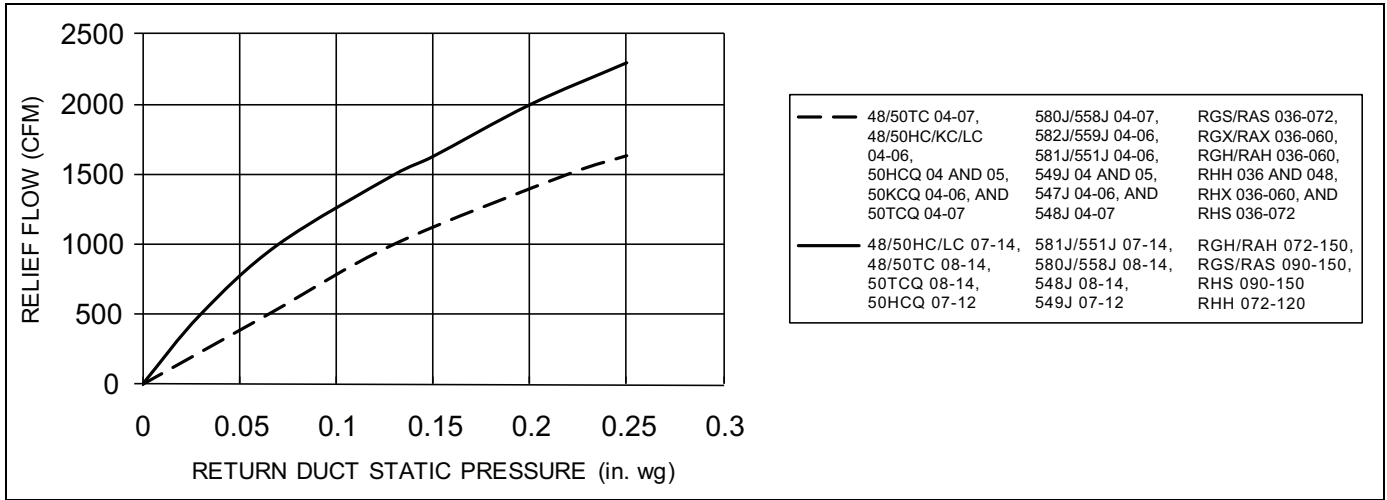

**Fig. 20 — Barometric Relief Flow Capacity**

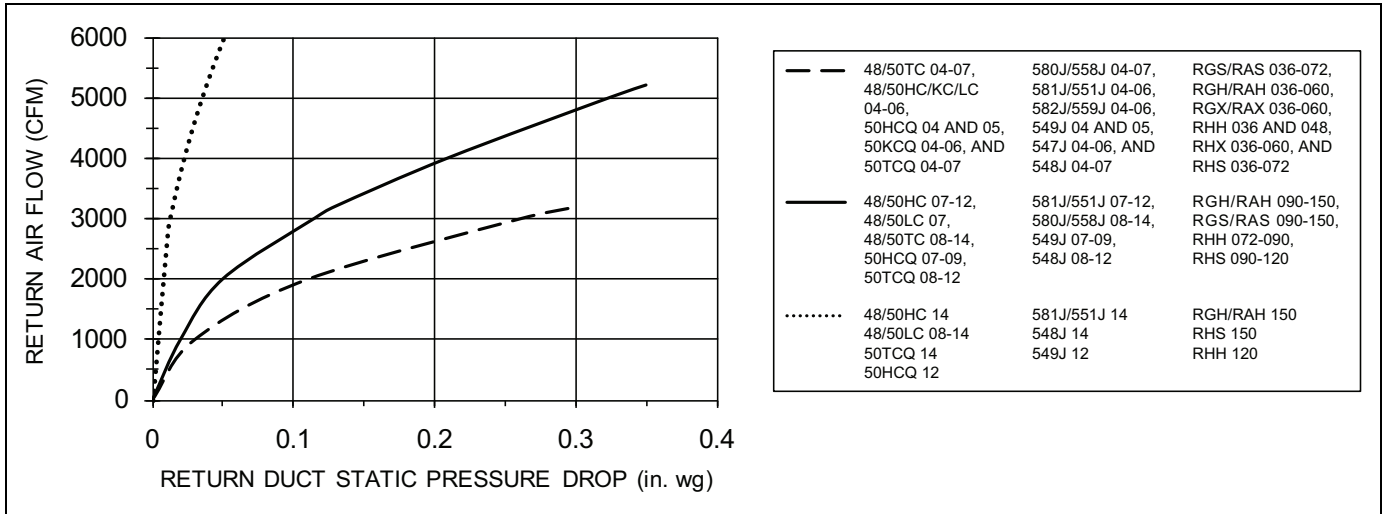

**Fig. 21 — Return Air Pressure Drop**

