



WeatherMaker® 48FE(G/H)04-06
Single Package Rooftop
Ultra Low NOx (14 ng/J) Gas Heating/Electric Cooling Unit
with Puron Advance™ (R-454B) Refrigerant

Installation Instructions

CONTENTS

	Page
SAFETY CONSIDERATIONS	1
MODEL NUMBER NOMENCLATURE AND DIMENSIONS	3
Rated Indoor Airflow	3
INSTALLATION	8
Jobsite Survey	8
Step 1 — Plan for Unit Location	8
• ROOF MOUNT	
Step 2 — Plan for Sequence of Unit Installation ...	8
• CURB-MOUNTED INSTALLATION	
• PAD-MOUNTED INSTALLATION	
• FRAME-MOUNTED INSTALLATION	
Step 3 — Inspect Unit	8
Step 4 — Provide Unit Support	8
• ROOF CURB MOUNT	
• SLAB MOUNT (HORIZONTAL UNITS ONLY)	
• ALTERNATE UNIT SUPPORT (IN LIEU OF CURB OR SLAB MOUNT)	
Step 5 — Field Fabricate Ductwork	10
Step 6 — Rig and Place Unit	10
• POSITIONING ON CURB	
Step 7 — Convert to Horizontal and Connect Ductwork (When Required)	11
Step 8 — Install Outside Air Hood	12
• ECONOMIZER HOOD PACKAGE REMOVAL (FACTORY OPTION)	
• ECONOMIZER HOOD SETUP	
Step 9 — Units with Hinged Panels Only	13
Step 10 — Install Flue Hood	13
Step 11 — Install Gas Piping	13
• FACTORY OPTION THRU-BASE CONNECTIONS (GAS CONNECTIONS)	
Step 12 — Install External Condensate Trap and Line	17
Step 13 — Make Electrical Connections	17
• FIELD POWER SUPPLY	
• UNITS WITH FACTORY-INSTALLED NON-FUSED DISCONNECT	
• UNITS WITHOUT FACTORY-INSTALLED NON-FUSED DISCONNECT	
• ALL UNITS	
• CONVENIENCE OUTLETS	
• FACTORY-OPTION THRU-BASE CONNECTIONS (ELECTRICAL CONNECTIONS)	
• UNITS WITHOUT THRU-BASE CONNECTIONS (ELECTRICAL CONNECTIONS)	
• FIELD CONTROL WIRING	
• THERMOSTAT	
• HEAT ANTICIPATOR SETTINGS	
• HUMIDI-MIZER® CONTROL CONNECTIONS	
• TYPICAL UNIT WIRING DIAGRAMS	
Integrated Gas Controller	27
Leak Dissipation System	29
• SEQUENCE OF OPERATION	
• LEAK DISSIPATION SYSTEM SELF-TEST	
• TROUBLESHOOTING	
Humidi-MiZer® Dehumidification System (Optional)	32
• NORMAL COOLING	
• DEHUM/MECH COOLING (SUBCOOLING) MODE	
• DEHUMIDIFICATION (HOT GAS REHEAT) MODE	
• REHEAT CONTROL	
Temporary Furnace Operation During Construction	33
EconomizerONE (Factory Option)	33
• ECONOMIZER SETTINGS	
• WIRING	
• SETUP AND CONFIGURATION	
• INSTALLING OPTIONAL HH57LW001 SINGLE OUTSIDE AIR ENTHALPY SENSOR	
• CHECKOUT	
• TROUBLESHOOTING	
SystemVu™ Controller (Factory Option)	55
Controller Options	55
• LOW AMBIENT	
Smoke Detectors	55
Step 14 — Adjust Factory-Installed Options	56
• SMOKE DETECTORS	
• ECONOMIZERONE OCCUPANCY SWITCH	
Step 15 — Install Accessories	56
Step 16 — Fan Speed Set Up	57
• UNITS WITH ELECTROMECHANICAL CONTROLS	
• UNITS WITH SYSTEMVU™ CONTROLS	
FASTENER TORQUE VALUES	59
START-UP CHECKLIST	CL-1

SAFETY CONSIDERATIONS

Installation and servicing of air-conditioning equipment can be hazardous due to system pressure and electrical components. Only trained and qualified service personnel should install, repair, or service air-conditioning equipment.

Untrained personnel can perform basic maintenance functions of cleaning coils and filters and replacing filters. All other operations should be performed by trained service personnel. When working on air-conditioning equipment, observe precautions in the literature, tags and labels attached to the unit, and other safety precautions that may apply.

Follow all safety codes, including ANSI (American National Standards Institute) Z223.1. Wear safety glasses and work gloves. Use quenching cloth for unbrazing operations. Have fire extinguisher available for all brazing operations.

It is important to recognize safety information. This is the safety-alert symbol . When you see this symbol on the unit and in

instructions or manuals, be alert to the potential for personal injury.

Understand the signal words DANGER, WARNING, CAUTION, and NOTE. These words are used with the safety-alert symbol. DANGER identifies the most serious hazards which **will** result in severe personal injury or death. WARNING signifies hazards which **could** result in personal injury or death. CAUTION is used to identify unsafe practices, which **may** result in minor personal injury or product and property damage. NOTE is used to highlight suggestions which **will** result in enhanced installation, reliability, or operation.

⚠ DANGER

ELECTRICAL SHOCK HAZARD

Failure to follow this warning will result in personal injury or death.

Before performing service or maintenance operations on unit, turn off main power switch to unit and install lock(s) and lockout tag(s). Ensure electrical service to rooftop unit agrees with voltage and amperage listed on the unit rating plate. Unit may have more than one power switch.

⚠ WARNING

FIRE, EXPLOSION HAZARD

Failure to follow this warning could result in death, serious personal injury and/or property damage.

Disconnect gas piping from unit when pressure testing at pressure greater than 0.5 psig (3450 Pa). Pressures greater than 0.5 psig will cause gas valve damage resulting in hazardous condition. If gas valve is subjected to pressure greater than 0.5 psig, it must be replaced before use. When pressure testing field-supplied gas piping at pressures of 0.5 psig or less, a unit connected to such piping must be isolated by closing the manual gas valve(s).

⚠ WARNING

UNIT OPERATION AND SAFETY HAZARD

Failure to follow this warning could cause personal injury, death and/or equipment damage.

R-454B is an A2L refrigerant. All service equipment or components must be A2L refrigerant rated. Do not use non-A2L rated equipment or components on R-454B refrigerant equipment.

⚠ WARNING

PERSONAL INJURY AND ENVIRONMENTAL HAZARD

Failure to follow this warning could cause personal injury or death.

Relieve pressure and recover all refrigerant before system repair or final unit disposal.

Wear safety glasses and gloves when handling refrigerants. Keep torches and other ignition sources away from refrigerants and oils.

⚠ WARNING

CARBON-MONOXIDE POISONING HAZARD

Failure to follow instructions could result in severe personal injury or death due to carbon-monoxide poisoning, if combustion products infiltrate into the building.

Check that all openings in the outside wall around the vent (and air intake) pipe(s) are sealed to prevent infiltration of combustion products into the building.

Check that furnace vent (and air intake) terminal(s) are not obstructed in any way during all seasons.

⚠ AVERTISSEMENT

RISQUE D'INTOXICATION AU MONOXYDE DE CARBONE

Si ces directives ne sont pas suivies, cela peut entraîner des blessures graves ou une intoxication au monoxyde de carbone pouvant causer la mort, si des produits de combustion s'infiltrent dans le bâtiment.

Vérifier que toutes les ouvertures pratiquées dans le mur extérieur autour du ou des tuyaux d'évent (et de la prise d'air) sont scellées de manière à empêcher l'infiltration de produits de combustion dans le bâtiment.

Veiller à ce que la ou les sorties de l'évent de l'appareil de chauffage (et la prise d'air) ne soient, en aucune façon, obstruées, quelle que soit la saison.

⚠ WARNING

FIRE HAZARD

Failure to follow this warning could result in severe personal injury and/or property damage.

Inlet pressure tap set screw must be tightened and 1/8-in. NPT pipe plug must be installed to prevent gas leaks.

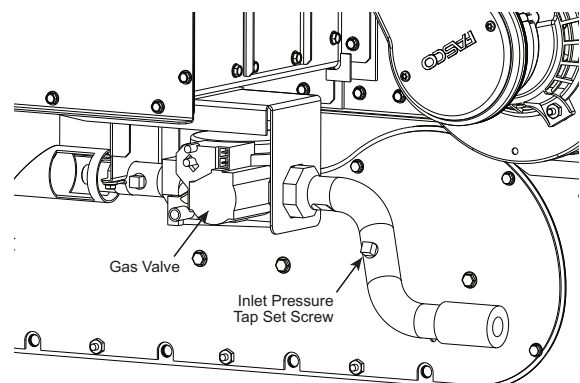

⚠ WARNING

FIRE HAZARD

Failure to follow this warning could result in severe personal injury and/or property damage.

Manifold pressure tap set screw must be tightened and 1/8-in. NPT pipe plug must be installed to prevent gas leaks.

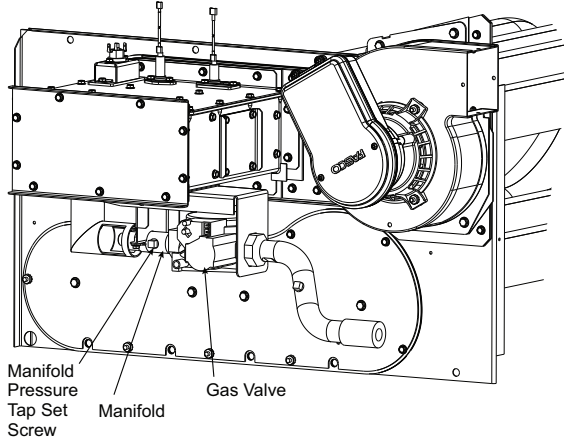

⚠ CAUTION

UNIT OPERATION HAZARD

Failure to follow this warning can result in equipment damage.

Units can not operated at altitudes greater than 7,800 feet under any circumstances.

⚠ CAUTION

UNIT OPERATION HAZARD

Do not detach the burner box from the heat exchanger panel. If the burner box must be replaced, refer to the Service and Maintenance Instructions for the unit. Failure to follow this caution may result in equipment damage.

⚠ ATTENTION

A particular air odor may be experienced coming from the flue discharge during initial gas heating start up. This is normal and will subside after minimal use.

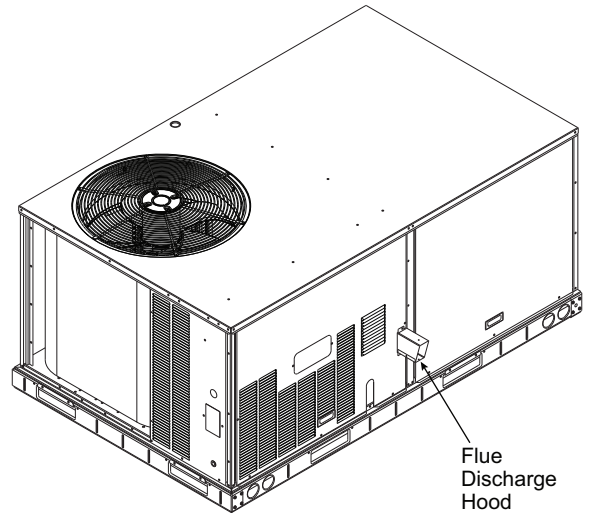

⚠ WARNING

UNIT OPERATION HAZARD

Failure to follow this warning can result in equipment damage.

Do Not adjust the inducer motor. The inducer motor is factory set; no field adjustment is required.

⚠ WARNING

Use caution when servicing compressor terminal pins. System or compressor abnormalities can dislodge pins allowing oil and refrigerant to vent under pressure.

⚠ AVERTISSEMENT

Soyez prudent lors de l'entretien des bornes du compresseur. Les anomalies du système ou du compresseur peuvent déloger les bornes, permettant à l'huile et au réfrigérant de s'évacuer sous pression.

⚠ CAUTION

PERSONAL INJURY HAZARD

Failure to follow this caution may result in personal injury. Sheet metal parts may have sharp edges or burrs. Use care and wear appropriate protective clothing, safety glasses and gloves when handling parts and servicing air conditioning equipment.

⚠ CAUTION

UNIT OPERATION HAZARD

Failure to follow this warning can result in equipment damage.

Units can not operated with LP (liquid propane) gas under any circumstances.

MODEL NUMBER NOMENCLATURE AND DIMENSIONS

See Fig. 1 for 48FE(G/H) model number nomenclature. See Fig. 2 for unit dimensional drawings. Figure 2 also shows service clearance dimensions.

Rated Indoor Airflow

Table 1 lists the rated indoor airflow used for the AHRI efficiency rating for the units covered in this document.

Table 1 — Rated Indoor Airflow

MODEL NUMBER	RATED INDOOR AIRFLOW (cfm)
48FE(G/H)A/B/04	1050
48FE(G/H)A/B/05	1500
48FE(G/H)A/B06	1500

Position:	1	2	3	4	5	6	7	8	9	10	11	12	13	14	15	16	17	18
Example:	4	8	F	E	G	A	0	4	A	2	A	6	-	0	A	0	A	0

Unit Heat Type
48 = Gas Heat Packaged Rooftop

Model Series — WeatherMaker®
FE = Entry Tier Puron Advance™

Heat Size
G = Ultra Low NOx - Low Heat (14 ng/J)^a
H = Ultra Low NOx - Medium Heat (14 ng/J)^a

Refrig. Systems Options
A = Std One Stage Cooling Models
B = Std One Stage Cooling Models with Humidi-MiZer^{®b}

Cooling Tons
04 = 3 tons
05 = 4 tons
06 = 5 tons

Sensor Options
A = None
B = Return Air (RA) Smoke Detector
C = Supply Air (SA) Smoke Detector
D = RA + SA Smoke Detector
J = Condensate Overflow Switch
K = Condensate Overflow Switch and RA Smoke Detector
L = Condensate Overflow Switch and RA + SA Smoke Detectors
M = Condensate Overflow Switch and SA Smoke Detector

Fan Options
2 = Standard/Medium Static — EcoBlue Vane Axial Fan
3 = High Static — EcoBlue Vane Axial Fan
5 = Standard/Medium Static — EcoBlue Vane Axial Fan and Filter Status Switch
6 = High Static — EcoBlue Vane Axial Fan and Filter Status Switch

Coil Options (Outdoor - Indoor — Hail Guard)
A = Al/Cu - Al/Cu
B = Precoat Al/Cu - Al/Cu
C = E-coat Al/Cu - Al/Cu
D = E-coat Al/Cu - E-coat Al/Cu
M = Al/Cu - Al/Cu — Louvered Hail Guard
N = Precoat Al/Cu - Al/Cu — Louvered Hail Guard
P = E-coat Al/Cu - Al/Cu — Louvered Hail Guard
Q = E-coat Al/Cu - E-coat Al/Cu — Louvered Hail Guard
R = Cu/Cu - Al/Cu — Louvered Hail Guard
S = Cu/Cu - Cu/Cu — Louvered Hail Guard

^a All Ultra Low NOx models include Stainless Steel Heat Exchanger.
^b Units with Humidi-MiZer System include Low Ambient controller.
^c The following are not available as a factory-installed options for models with this voltage code: Humidi-MiZer System, Coated Coils or Cu Fin Coils, Louvered Hail Guards, Economizer, Powered Convenience Outlet or Upgraded MERV filters.
^d Not available as a factory-installed option on single-phase models (voltage option "3")

Packaging & Seismic Compliance
0 = Standard

Electrical Options
A = None
C = Non-Fused Disconnect (NFDC)
D = Thru-the-Base (TTB) Connections
F = Non-Fused Disconnect and TTB Connections
N = Phase Monitor Protection (PMR)^d
Q = PMR + NFDC^d
R = PMR + TTB^d
T = PMR + NFDC + TTB^d

Service Options
0 = None
1 = Unpowered Convenience Outlet (NPCO)
2 = Powered Convenience Outlet (PCO)^d
3 = Hinged Panels (HP)
4 = Hinged Panels + NPCO
5 = Hinged Panels + PCO^d
6 = MERV-13 Filters (M13)^d
7 = NPCO + MERV-13 Filters^d
8 = PCO + MERV-13 Filters^d
9 = Hinged Panels + MERV-13 Filters^d
A = HP + NPCO + MERV-13 Filters^d
B = HP + PCO + MERV-13 Filters^d

Intake / Exhaust Options
A = None
B = Standard Leak Economizer with Barometric Relief^d
F = Standard Leak Enthalpy Economizer with Barometric Relief^d
L = ULL (Ultra Low Leak) Temperature Economizer with Barometric Relief and CO2 Sensor^d
M = ULL Enthalpy Economizer with Barometric Relief and CO2 Sensor^d
U = ULL Temperature Economizer with Barometric Relief^d
W = ULL Enthalpy Economizer with Barometric Relief^d

Base Unit Controls
0 = Electromechanical Controller
3 = SystemVu™ Controller
8 = Electromechanical Controls with POL224 EconomizerONE (with Fault Detection and Diagnostic)

Design Revision
- = Factory Design Revision

Voltage
3 = 208/230-1-60[°]
5 = 208/230-3-60
6 = 460-3-60

Fig. 1 — 48FE 04-06 Ultra Low NOx Model Number Nomenclature

NOTES:

1. DIMENSIONS ARE IN INCHES, DIMENSIONS IN [] ARE IN MILLIMETERS.
2. CENTER OF GRAVITY
3. DIRECTION OF AIR FLOW
4. ALL VIEW DRAWN USING 3RD ANGLE

UNIT	J	K
48FE**04	33 3/8 [847]	18 5/8 [472]
48FE**05	33 3/8 [847]	14 7/8 [377]
48FE**06	33 3/8 [847]	14 7/8 [377]
48FE**07	41 3/8 [1051]	18 5/8 [472]



THIS DOCUMENT IS THE PROPERTY OF CARRIER CORPORATION AND IS DELIVERED UPON THE EXPRESS CONDITION THAT THE CONTENTS WILL NOT BE DISCLOSED OR USED WITHOUT CARRIER CORPORATION'S WRITTEN CONSENT.

SUBMISSION OF THESE DRAWINGS OR DOCUMENTS DOES NOT CONSTITUTE PART PERFORMANCE OR ACCEPTANCE OF CONTRACT.

CONNECTION SIZES	
A	1 3/8" [35] DIA FIELD POWER SUPPLY HOLE
B	2" [50] DIA POWER SUPPLY KNOCKOUT
C	1 3/4" [51] DIA GAUGE ACCESS PLUG
D	7/8" [22] DIA FIELD CONTROL WIRING HOLE
E	3/4"-14 NPT CONDENSATE DRAIN
F	1/2"-14 NPT GAS CONNECTION
G	2 1/2" [64] DIA POWER SUPPLY KNOCK-OUT

THRU-THE-BASE CHART THESE HOLES REQUIRED FOR USE CRBTMPWRO08A00, 009A00			
	THREADED CONDUIT SIZE	WIRE USE	REQ'D HOLE SIZES (MAX.)
W	1/2"	115V	7/8" [22.2]
X	1/2"	24V	7/8" [22.2]
Y	3/4"	POWER	1-1/8" [28.6]
Z*	(009A00) 1/2" FPT	GAS	1-1/8" [28.6]

FOR "THRU-THE-BASEPAN" FACTORY OPTION, FITTINGS FOR ONLY X, Y, & Z ARE PROVIDED

* (008A00) PROVIDES 3/4" FPT THRU CURB FLANGE & FITTING.

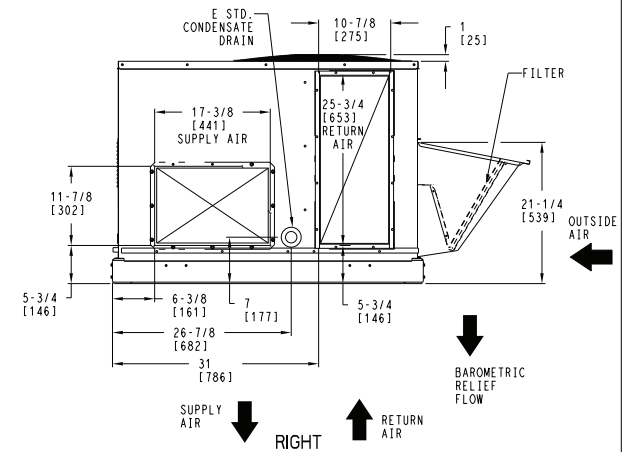
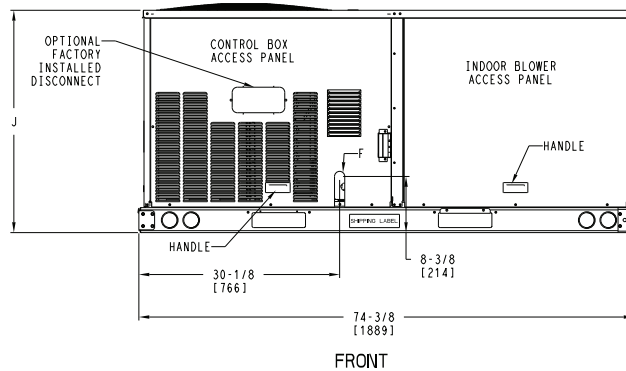
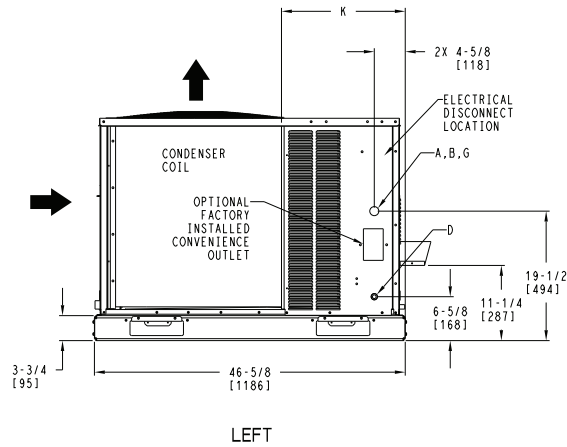
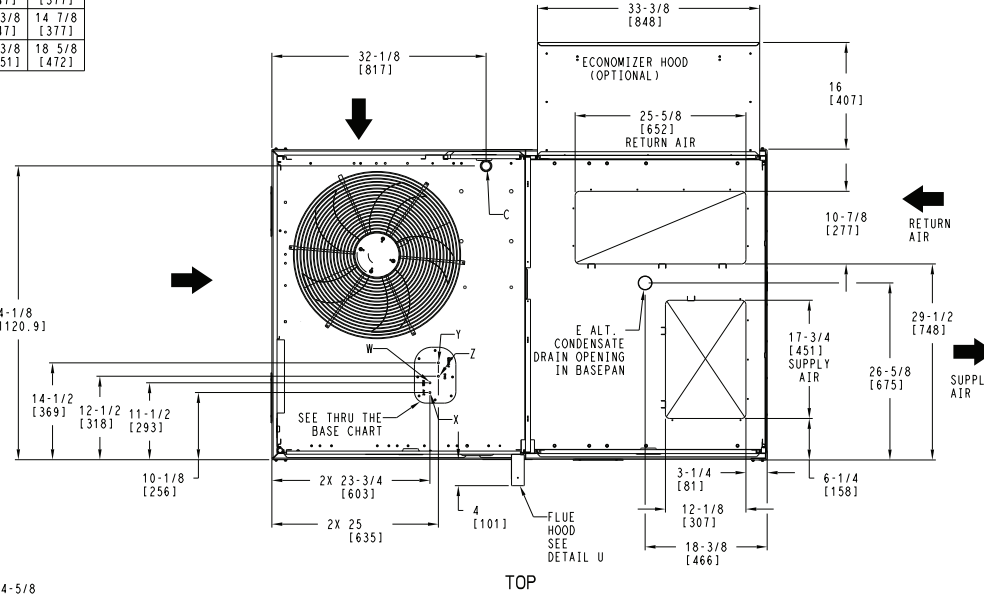
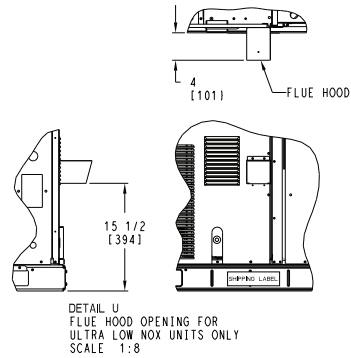

ITC CLASSIFICATION	SHEET	DATE	SUPERCEDES	48FE 04-07 SINGLE PACKAGE ELECTRICAL COOLING WITH GAS HEAT	48TC006964	REV
U.S. ECCN:NSR	1 OF 3	11/17/23	-			-

Fig. 2 — Unit Dimensional Drawing



THIS DOCUMENT IS THE PROPERTY OF CARRIER CORPORATION AND IS DELIVERED UPON THE EXPRESS CONDITION THAT THE CONTENTS WILL NOT BE DISCLOSED OR USED WITHOUT CARRIER CORPORATION'S WRITTEN CONSENT. SUBMISSION OF THESE DRAWINGS OR DOCUMENTS DOES NOT CONSTITUTE PART PERFORMANCE OR ACCEPTANCE OF CONTRACT.

UNIT	STD. UNIT WEIGHT *		CORNER WEIGHT (A)		CORNER WEIGHT (B)		CORNER WEIGHT (C)		CORNER WEIGHT (D)		C.G.			HEIGHT
	LBS.	KG.	LBS.	KG.	LBS.	KG.	LBS.	KG.	LBS.	KG.	X	Y	Z	
48FE**04	482	219	113	51	116	53	128	58	125	57	37 5/8 [956]	24 9/16 [624]	18 1/4 [464]	
48FE**05	543	246	138	63	133	60	133	60	138	63	36 1/2 [927]	23 3/8 [594]	18 [457]	
48FE**06	556	252	142	64	136	62	136	62	142	64	36 1/2 [927]	23 3/8 [594]	18 [457]	
48FE**07	607	275	162	73	152	69	141	64	151	68	36 [914]	22 1/2 [572]	19 3/8 [492]	

* STANDARD UNIT WEIGHT IS WITH LOW GAS HEAT AND WITHOUT PACKAGING. FOR OTHER OPTIONS AND ACCESSORIES, REFER TO THE PRODUCT DATA CATALOG.

THIS TABLE IS FOR "ULTRA LOW NOX" UNITS ONLY

UNIT	STD. UNIT WEIGHT**		CORNER WEIGHT (A)		CORNER WEIGHT (B)		CORNER WEIGHT (C)		CORNER WEIGHT (D)		C.G.			HEIGHT
	LBS.	KG.	LBS.	KG.	LBS.	KG.	LBS.	KG.	LBS.	KG.	X	Y	Z	
48FEG*04	512	233	120	55	122	55	136	62	134	61	37 1/2 [953]	24 11/16 [627]	18 1/8 [460]	
48FEG*05	573	260	146	66	139	63	141	64	147	67	36 3/8 [924]	23 1/2 [597]	18 [457]	
48FEG*06	586	266	149	68	143	65	144	65	151	69	36 3/8 [924]	23 1/2 [597]	18 [457]	

** STANDARD UNIT WEIGHT IS WITH WITHOUT PACKAGING. FOR OTHER OPTIONS AND ACCESSORIES, REFER TO THE PRODUCT DATA CATALOG.

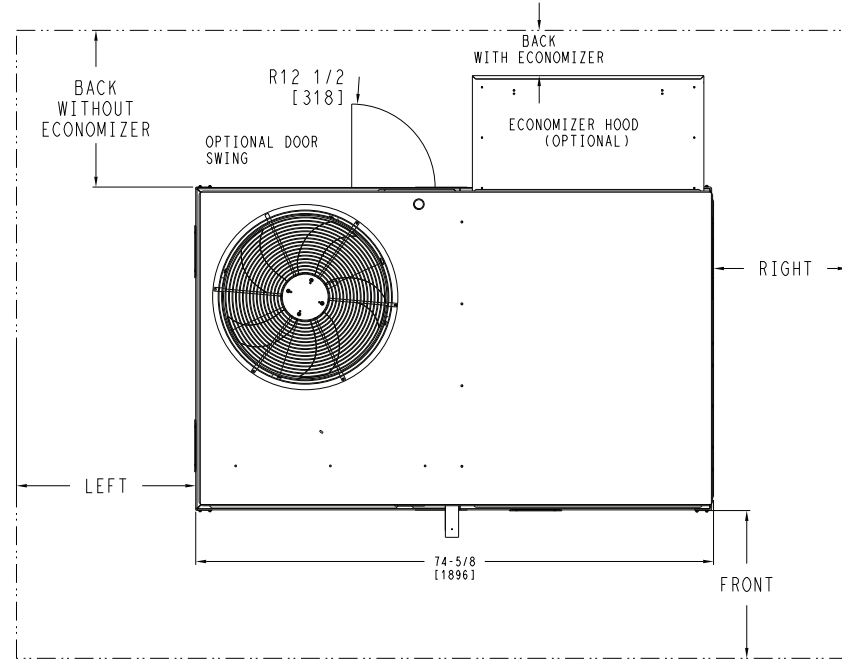
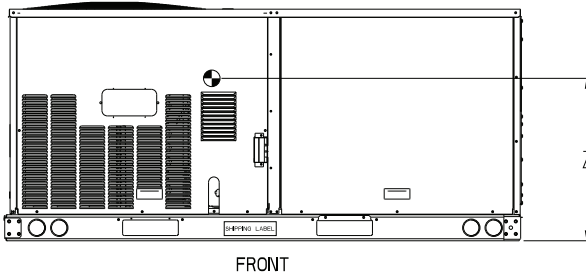
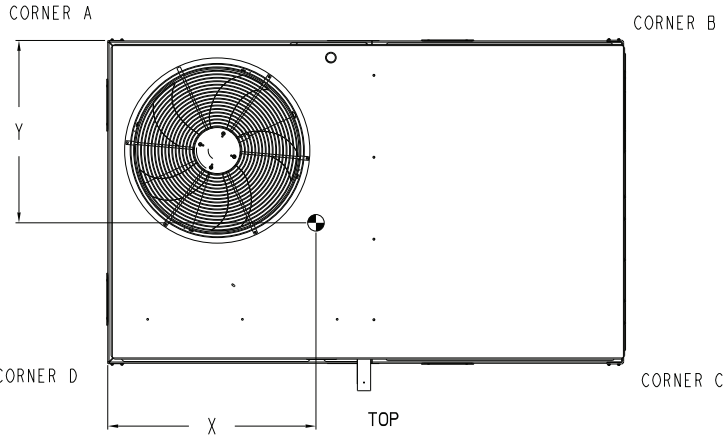

NOTES:

1. FOR ALL MINIMUM CLEARANCES LOCAL CODES OR JURISDICTIONS MAY PREVAIL.

SURFACE	CLEARANCE		OPERATING CLEARANCE
	SERVICE WITH: CONDUCTIVE BARRIER	SERVICE WITH: NONCONDUCTIVE BARRIER	
FRONT	48 [1219mm]	36 [914mm]	18 [457mm]
LEFT	48 [1219mm]	42 [1067mm]	18 [457mm]
BACK W/O HOOD	48 [1219mm]	42 [1067mm]	18 [457mm]
BACK W/HOOD	36 [914mm]	36 [914mm]	18 [457mm]
RIGHT	36 [914mm]	36 [914mm]	18 [457mm]
TOP	72 [1829mm]	72 [1829mm]	72 [1829mm]

ITC CLASSIFICATION	SHEET	DATE	SUPERCEDES	48FE 04-07 SINGLE PACKAGE ELECTRICAL COOLING WITH GAS HEAT	48TC006964	REV
U.S. ECCN:NSR	2 OF 3	11/17/23	-			-

Fig. 2 — Unit Dimensional Drawing (cont)



THIS DOCUMENT IS THE PROPERTY OF CARRIER CORPORATION AND IS DELIVERED UPON THE EXPRESS CONDITION THAT THE CONTENTS WILL NOT BE DISCLOSED OR USED WITHOUT CARRIER CORPORATION'S WRITTEN CONSENT.

SUBMISSION OF THESE DRAWINGS OR DOCUMENTS DOES NOT CONSTITUTE PART PERFORMANCE OR ACCEPTANCE OF CONTRACT.

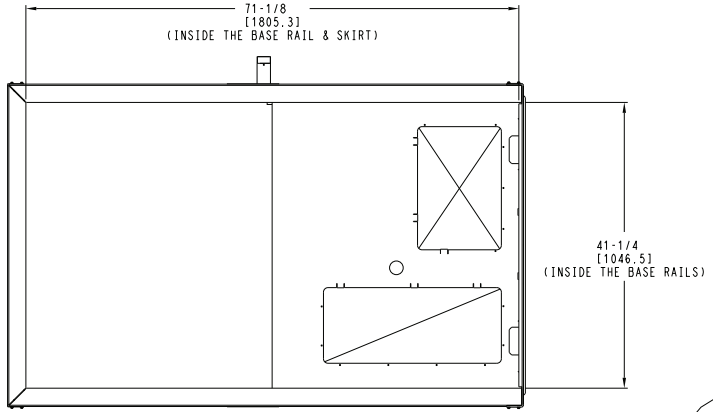
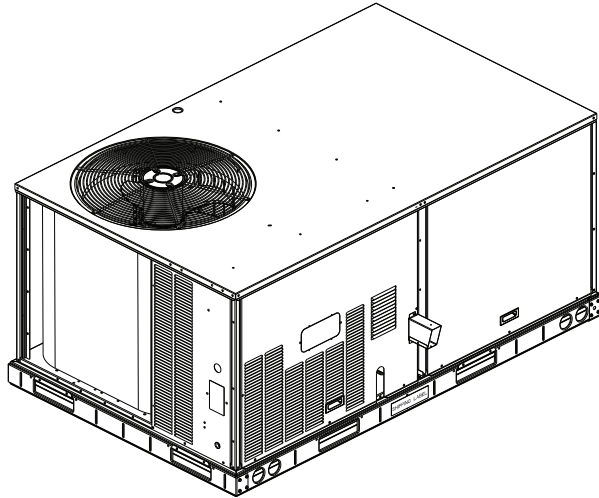

INSIDE BASERAIL DIMENSIONS

BOTTOM

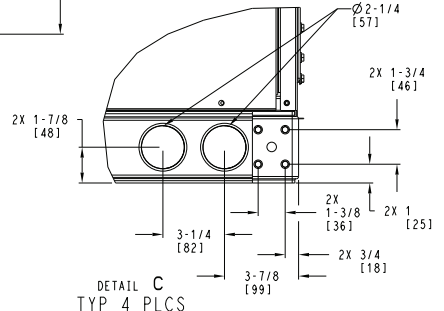

DETAIL C
TYP 4 PLCS

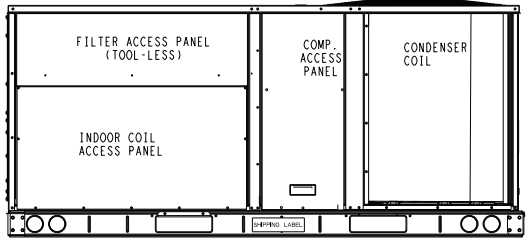

BACK

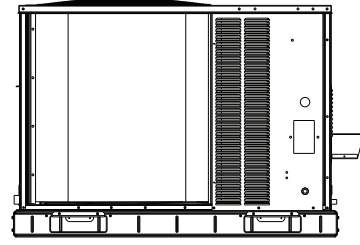

LEFT

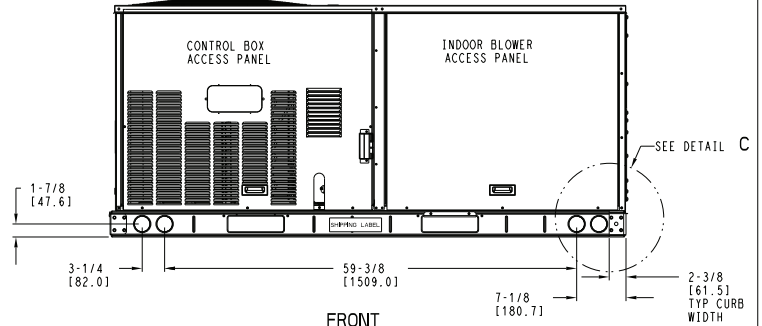

FRONT

ITC CLASSIFICATION	SHEET	DATE	SUPERCEDES	48FE 04-07 SINGLE PACKAGE ELECTRICAL COOLING WITH GAS HEAT	48TC006964	REV
U.S. ECCN:NSR	3 OF 3	11/17/23	-			-

Fig. 2 — Unit Dimensional Drawing (cont)

INSTALLATION

Jobsite Survey

Complete the following checks before installation.

1. Consult local building codes and the NEC (National Electrical Code) ANSI/NFPA 70 for special installation requirements.
2. Determine unit location (from project plans) or select unit location.
3. Check for possible overhead obstructions which may interfere with unit lifting or rigging.

Step 1 — Plan for Unit Location

Select a location for the unit and its support system (curb or other) that provides for the minimum clearances required for safety. This includes the clearance to combustible surfaces, unit performance and service access below, around and above unit as specified in unit drawings. See Fig. 2 on page 6.

NOTE: Consider also the effect of adjacent units.

Be sure that unit is installed such that snow will not block the combustion intake or flue outlet.

Unit may be installed directly on wood flooring or on Class A, B, or C roof-covering material when roof curb is used.

Do not install unit in an indoor location. Do not locate air inlets near exhaust vents or other sources of contaminated air. For proper unit operation, adequate combustion and ventilation air must be provided in accordance with Section 5.3 (Air for Combustion and Ventilation) of the National Fuel Gas Code, ANSI Z223.1 (American National Standards Institute) and NFPA (National Fire Protection Association) 54 TIA-54-84-1. In Canada, installation must be in accordance with the CAN1-B149 installation codes for gas burning appliances.

Although unit is weatherproof, avoid locations that permit water from higher level runoff and overhangs to fall onto the unit.

Locate mechanical draft system flue assembly at least 4 ft (1.2 m) from any opening through which combustion products could enter the building, and at least 4 ft (1.2 m) from any adjacent building (or per local code). Locate the flue assembly at least 10 ft (3.05 m) from an adjacent unit's fresh air intake hood if within 3 ft (0.91 m) of same elevation (or per local code). When unit is located adjacent to public walkways, flue assembly must be at least 7 ft (2.1 m) above grade.

Select a unit mounting system that provides adequate height to allow installation of condensate trap per requirements. Refer to Install External Condensate Trap and Line on page 17 for required trap dimensions.

ROOF MOUNT

Check building codes for weight distribution requirements. Unit operating weights are shown in Table 2.

Table 2 — Operating Weights

48FE(G/H)	UNIT lb (kg)		
	04	05	06
Base Unit	512 (233)	573 (260)	586 (266)
Economizer			
Vertical	50 (23)	50 (23)	50 (23)
Horizontal	80 (36)	80 (36)	80 (36)
Humidi-MiZer® System	50 (23)	50 (23)	80 (36)
Cu Fins	25 (11)	43 (20)	56 (25)
Powered Outlet	35 (16)	35 (16)	35 (16)
Curb			
14 in. (356 mm)	115 (52)	115 (52)	115 (52)
24 in. (610 mm)	197 (89)	197 (89)	197 (89)

Step 2 — Plan for Sequence of Unit Installation

The support method used for this unit will dictate different sequences for the steps of unit installation. For example, on curb-mounted units, some accessories must be installed on the unit before the unit is placed on the curb. Review the following for recommended sequences for installation steps.

CURB-MOUNTED INSTALLATION

1. Install curb.
2. Install field-fabricated ductwork inside curb.
3. Install accessory thru-base service connection package (affects curb and unit) (refer to accessory installation instructions for details).
4. Prepare bottom condensate drain connection to suit planned condensate line routing (refer to Install External Condensate Trap and Line on page 17 for details).
5. Rig and place unit.
6. Install outdoor air hood.
7. Install flue hood.
8. Install gas piping.
9. Install condensate line trap and piping.
10. Make electrical connections.
11. Install other accessories.

PAD-MOUNTED INSTALLATION

1. Prepare pad and unit supports.
2. Check and tighten the bottom condensate drain connection plug.
3. Rig and place unit.
4. Convert unit to side duct connection arrangement.
5. Install field-fabricated ductwork at unit duct openings.
6. Install outdoor air hood.
7. Install flue hood.
8. Install gas piping.
9. Install condensate line trap and piping.
10. Make electrical connections.
11. Install other accessories.

FRAME-MOUNTED INSTALLATION

Frame-mounted applications generally follow the sequence for a curb installation. Adapt the sequence as required to suit specific installation plan.

Step 3 — Inspect Unit

Inspect unit for transportation damage. File any claim with transportation agency.

Confirm before installation of unit that voltage, amperage and circuit protection requirements listed on unit data plate agree with power supply provided.

On units with hinged panel option, check to be sure all latches are snug and in closed position.

Locate the carton containing the outside air hood parts. Do not remove carton until unit has been rigged and located in final position.

Step 4 — Provide Unit Support

ROOF CURB MOUNT

Accessory roof curb details and dimensions are shown in Fig. 3 (on page 9). Assemble and install accessory roof curb in accordance with instructions shipped with the curb.

ROOF CURB ACCESSORY #	A
CRRFCURB001A01	14" [356]
CRRFCURB002A01	24" [610]

- NOTES:
1. ROOFCURB ACCESSORY IS SHIPPED DISASSEMBLED.
 2. INSULATED PANELS: 25.4 [1"] THK. POLYURETHANE FOAM, 44.5 [1-3/4"] # DENSITY.
 3. DIMENSIONS IN [] ARE IN MILLIMETERS.
 4. ROOFCURB: 18 GAUGE STEEL.
 5. ATTACH DUCTWORK TO CURB. (FLANGES OF DUCT REST ON CURB).
 6. SERVICE CLEARANCE 4 FEET ON EACH SIDE.
 7.  DIRECTION OF AIR FLOW.
 8. CONNECTOR PACKAGE CRBTMPWR001A01 IS FOR THRU-THE-CURB GAS TYPE PACKAGE CRBTMPWR003A01 IS FOR THRU-THE-BOTTOM TYPE GAS CONNECTIONS.

CONNECTOR PKG. ACC.	GAS CONNECTION TYPE	GAS FITTING	POWER WIRING FITTING	CONTROL WIRING FITTING	ACCESSORY CONVENIENCE OUTLET WIRING CONNECTOR
CRBTMPWR001A01	THRU THE CURB	3/4" [19] NPT	3/4" [19] NPT	1/2" [12.7] NPT	1/2" [12.7] NPT
CRBTMPWR003A01	THRU THE BOTTOM	1/2" [12.7] NPT			

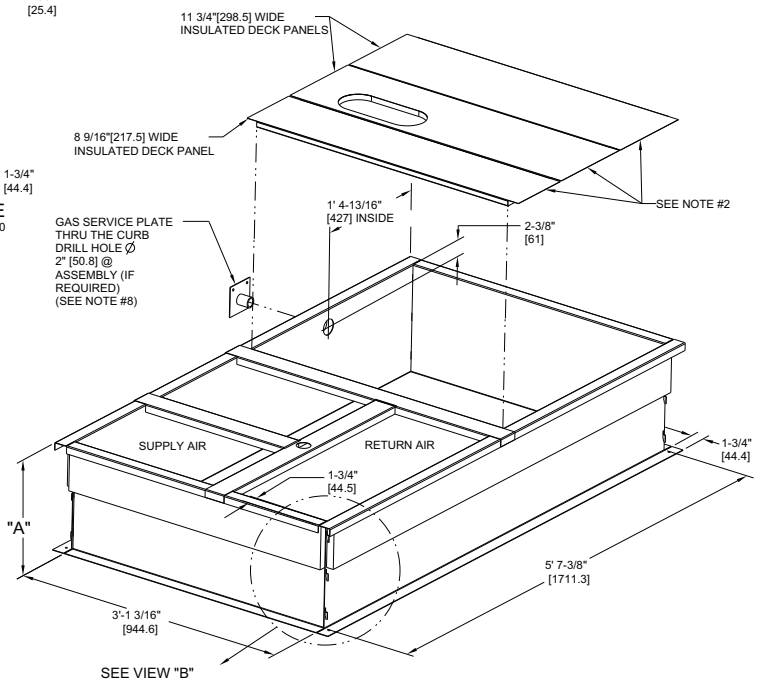
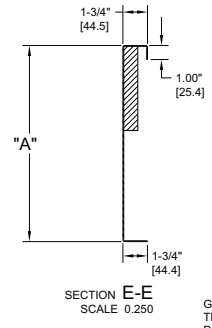
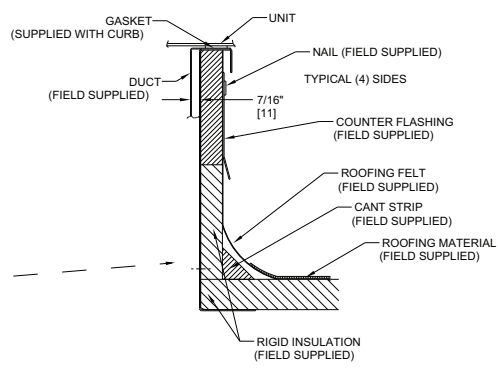
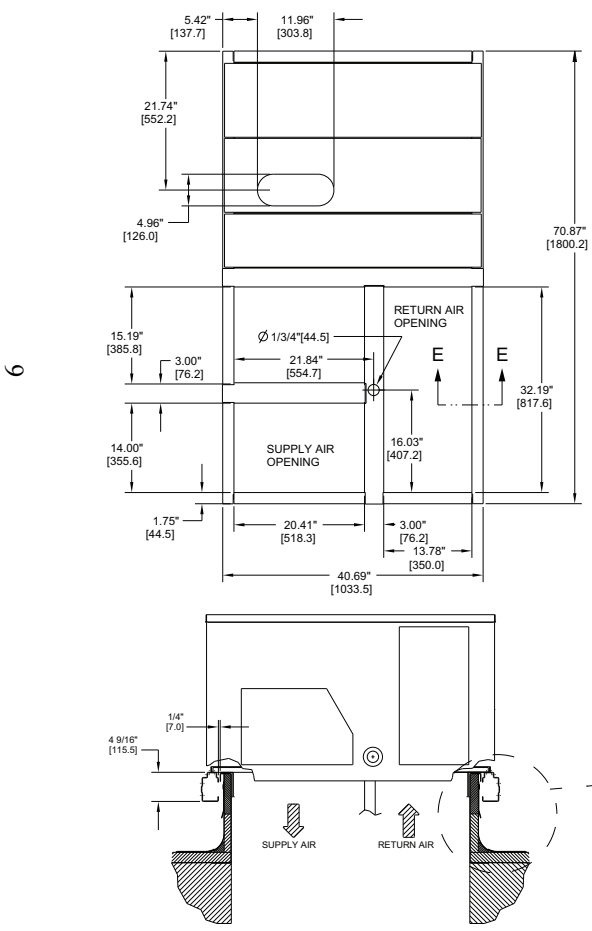

Fig. 3 — Roof Curb Details

48TC400427

NOTE: The gasketing of the unit to the roof curb is critical for a watertight seal. Install gasket supplied with the roof curb as shown in Fig. 3. Improperly applied gasket can also result in air leaks and poor unit performance.

Curb should be level. This is necessary for unit drain to function properly. Unit leveling tolerances are shown in Fig. 4. Refer to Accessory Roof Curb Installation Instructions for additional information as required.

Install insulation, cant strips, roofing felt, and counter flashing as shown. Ductwork must be attached to curb and not to the unit. The accessory thru-the-base power and gas connection package must be installed before the unit is set on the roof curb. If field-installed thru-the-roof curb gas connections are desired, use factory-supplied 1/2 in. pipe coupling and gas plate assembly to mount the thru-the-roof curb connection to the roof curb. Gas connections and power connections to the unit must be field-installed after the unit is installed on the roof curb.

NOTE: If electric and control wiring is to be routed through the basepan, attach the accessory thru-the-base service connections to the basepan in accordance with the accessory installation instructions.

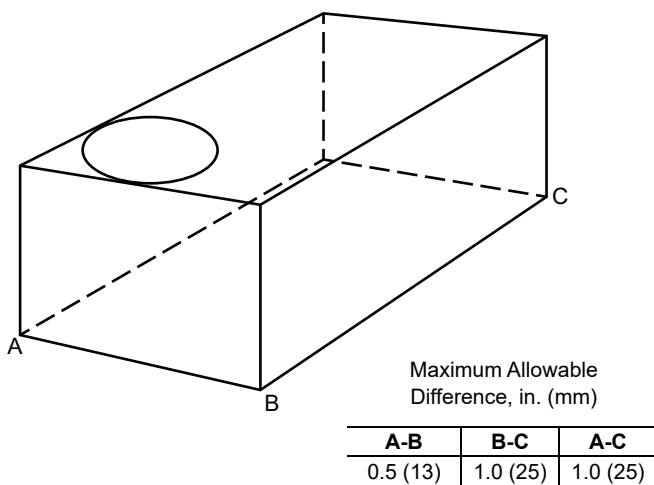

Fig. 4 – Unit Leveling Tolerances

SLAB MOUNT (HORIZONTAL UNITS ONLY)

Provide a level concrete slab that extends a minimum of 6 in. (150 mm) beyond unit cabinet. Install a gravel apron in front of condenser coil air inlet to prevent grass and foliage from obstructing airflow.

NOTE: Horizontal units may be installed on a roof curb if required.

ALTERNATE UNIT SUPPORT (IN LIEU OF CURB OR SLAB MOUNT)

A non-combustible sleeper rail can be used in the unit curb support area. If sleeper rails cannot be used, support the long sides of the unit with a minimum of 3 equally spaced 4 in. x 4 in. (102 mm x 102 mm) pads on each side.

Step 5 – Field Fabricate Ductwork

Cabinet return-air static pressure (a negative condition) shall not exceed 0.35 in. wg (87 Pa) with economizer or 0.45 in. wg (112 Pa) without economizer.

For vertical ducted applications, secure all ducts to roof curb and building structure. Do not connect ductwork to unit.

Fabricate supply ductwork so that the cross sectional dimensions are equal to or greater than the unit supply duct opening dimensions for the first 18 in. (458 mm) of duct length from the unit basepan.

Insulate and weatherproof all external ductwork, joints, and roof openings with counter flashing and mastic in accordance with applicable codes.

Ducts passing through unconditioned spaces must be insulated and covered with a vapor barrier.

If a plenum return is used on a vertical unit, the return should be ducted through the roof deck to comply with applicable fire codes.

A minimum clearance is not required around ductwork.

Step 6 – Rig and Place Unit

⚠ CAUTION

PROPERTY DAMAGE HAZARD

Failure to follow this caution may result in damage to roofing materials.

Membrane roofs can be cut by sharp sheet metal edges. Be careful when placing any sheet metal parts on such roof.

Keep unit upright and do not drop. Spreader bars are required. Rollers may be used to move unit across a roof. Rigging materials under unit (cardboard or wood) must be removed PRIOR to placing the unit on the roof curb. Level by using unit frame as a reference. See Table 2 and Fig. 5 for additional information.

Lifting holes are provided in base rails as shown in Fig. 5. Refer to rigging instructions on unit.

Rigging materials under unit (cardboard or wood to prevent basepan damage) must be removed PRIOR to placing the unit on the roof curb.

When using the standard side drain connection, ensure the red plug in the alternate bottom connection is tight. Do this before setting the unit in place. The red drain plug can be tightened with a 1/2 in. square socket drive extension. For further details, see “Install External Condensate Trap and Line” on page 17.

Before setting the unit onto the curb, recheck gasketing on curb.

POSITIONING ON CURB

⚠ CAUTION

UNIT DAMAGE HAZARD

Failure to follow this caution may result in equipment damage.

All panels must be in place when rigging. Unit is not designed for handling by fork truck when packaging is removed.

If using top crate as spreader bar, once unit is set, carefully lower wooden crate off building roof top to ground. Ensure that no people or obstructions are below prior to lowering the crate.

Position unit on roof curb so that the following clearances are maintained: 1/4 in. (6.4 mm) clearance between the roof curb and the base rail inside the front and rear, 0.0 in. clearance between the roof curb and the base rail inside on the duct end of the unit. This will result in the distance between the roof curb and the base rail inside on the condenser end of the unit being approximately 1/4 in. (6.4 mm).

Although unit is weatherproof, guard against water from higher level runoff and overhangs.

Flue vent discharge must have a minimum horizontal clearance of 4 ft (1220 mm) from electric and gas meters, gas regulators, and gas relief equipment. Minimum distance between unit and other electrically live parts is 48 in. (1220 mm).

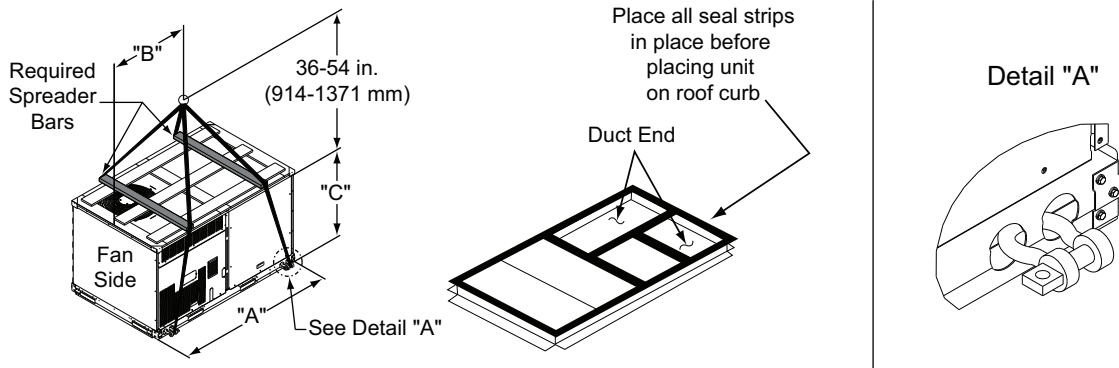

NOTE(S):

1. SPREADER BARS ARE REQUIRED. Top damage will occur if spreader bars are not used.
2. Hook rigging shackles through holes in base rail, as shown in Detail A. Holes in base rails are centered around the unit center of gravity. Use wooden top to prevent rigging straps from damaging unit.

UNIT	MAXIMUM WEIGHT		DIMENSIONS					
			A		B		C	
	lb	kg	in.	mm	in.	mm	in.	mm
48FEG/H04	814	369	74.5	1890	37.5	955	33.5	850
48FEG/H05	920	417	74.5	1890	36.4	925	33.5	850
48FEG/H06	933	423	74.5	1890	36.4	925	33.5	850

Fig. 5 – Rigging Details

Flue gas can deteriorate building materials. Orient unit such that flue gas will not affect building materials. Locate mechanical draft system flue assembly at least 48 in. (1220 mm) from an adjacent building or combustible material.

NOTE: Installation of accessory flue discharge deflector kit will reduce the minimum clearance to combustible material to 18 in. (460 mm).

After unit is in position, remove rigging skids and shipping materials.

Step 7 – Convert to Horizontal and Connect Ductwork (When Required)

Unit is shipped in the vertical duct configuration. Unit without factory-installed economizer or return-air smoke detector option may be field-converted to horizontal ducted configuration. To convert to horizontal configuration, remove screws from side duct opening covers (see Fig. 6) and remove covers. Use the screws to install the covers on vertical duct openings with the insulation-side down. The panels must be inserted into the notches on the basepan to properly seal. The notches are covered by the tape used to secure the insulation to the basepan and are not easily seen. See Fig. 7 for position of the notches in the basepan. Seals around duct openings must be tight. Secure with screws as shown in Fig. 8. Cover seams with foil duct tape.

Field-supplied flanges should be attached to horizontal duct openings and all ductwork should be secured to the flanges. Insulate and weatherproof all external ductwork, joints, and roof or building openings with counter flashing and mastic in accordance with applicable codes.

Do not cover or obscure visibility to the unit's informative data plate when insulating horizontal ductwork.

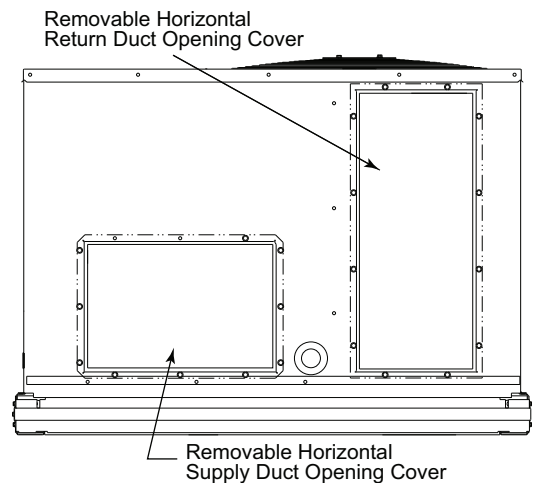

Fig. 6 – Horizontal Conversion Panels

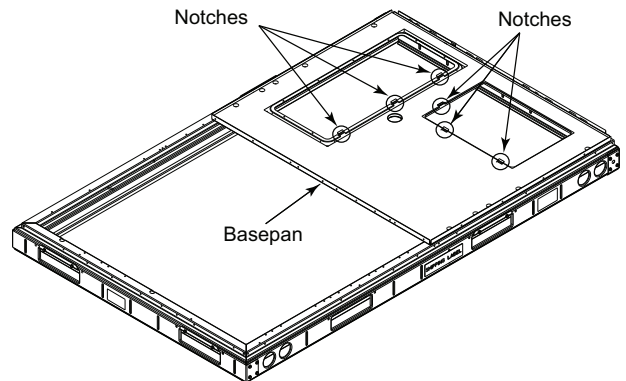

Fig. 7 – Location of Notches

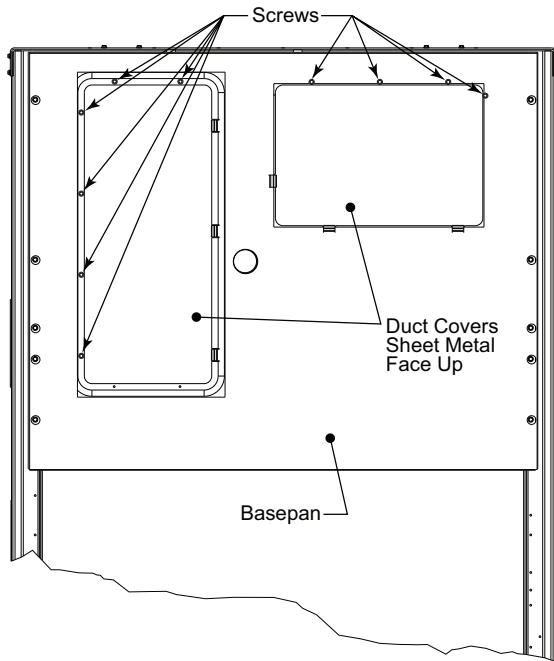

Fig. 8 – Horizontal Duct Panels In Place

Step 8 – Install Outside Air Hood

ECONOMIZER HOOD PACKAGE REMOVAL (FACTORY OPTION)

NOTE: Economizer is not available as a factory installed option for single phase (-3 voltage code) models.

The hood is shipped in knock-down form and must be field assembled. The indoor coil access panel is used as the hood top while the hood sides, divider and filter are packaged together, attached to a metal support tray using plastic stretch wrap, and shipped in the return air compartment behind the indoor coil access panel. The hood assembly's metal tray is attached to the basepan and also attached to the damper using 2 plastic tie-wraps.

1. To gain access to the hood, remove the filter access panel. See Fig. 9.
2. Locate the (2) screws holding the metal tray to the basepan and remove. Locate and cut the (2) plastic tie-wraps securing the assembly to the damper. See Fig. 10. Be careful to not damage any wiring or cut tie-wraps securing any wiring.
3. Carefully lift the hood assembly (with metal tray) through the filter access opening and assemble per the steps outlined in the Economizer Hood Setup section.

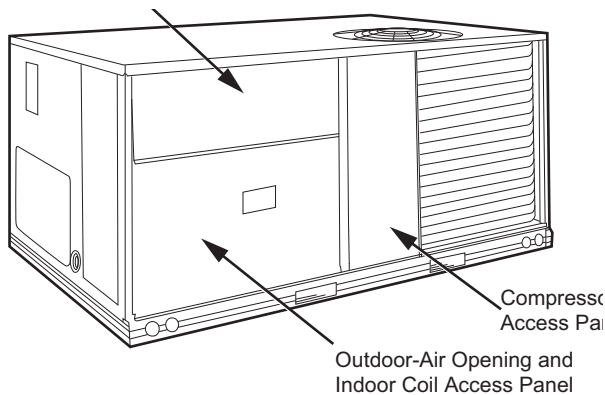

Fig. 9 – Typical Access Panel Locations

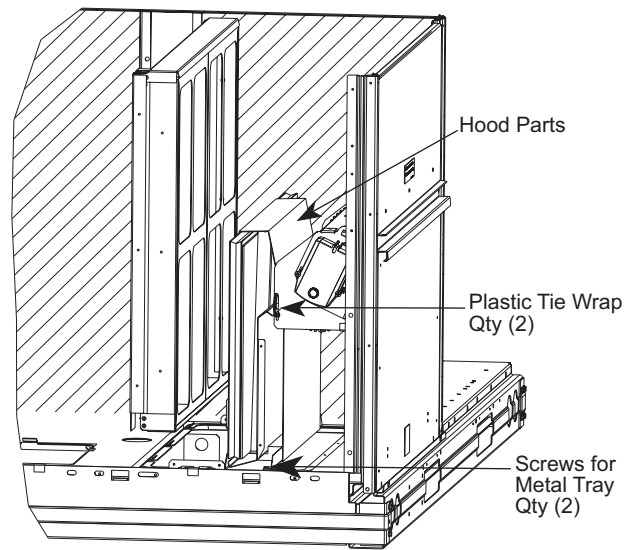

Fig. 10 – Economizer Hood Parts Location

ECONOMIZER HOOD SETUP

NOTE: If the power exhaust accessory is to be installed on the unit, the hood shipped with the unit will not be used and must be discarded. Save the aluminum filter for use in the power exhaust hood assembly.

1. The indoor coil access panel will be used as the top of the hood. Remove the screws along the sides and bottom of the indoor coil access panel. See Fig. 11.
2. Swing out indoor coil access panel and insert the hood sides under the panel (hood top). Use the screws provided to attach the hood sides to the hood top. Use screws provided to attach the hood sides to the unit. See Fig. 12.
3. Remove the shipping tape holding the economizer barometric relief damper in place (economizer only).
4. Insert the hood divider between the hood sides. See Fig. 12 and 13. Secure hood divider with 2 screws on each hood side. The hood divider is also used as the bottom filter rack for the aluminum filter.
5. Open the filter clips which are located underneath the hood top. Insert the aluminum filter into the bottom filter rack (hood divider). Push the filter into position past the open filter clips. Close the filter clips to lock the filter into place. See Fig. 13.
6. Caulk the ends of the joint between the unit top panel and the hood top.
7. Replace the filter access panel.

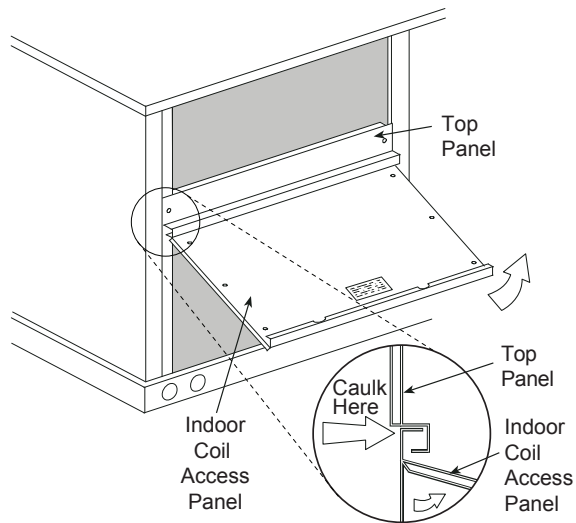

Fig. 11 – Indoor Coil Access Panel Relocation

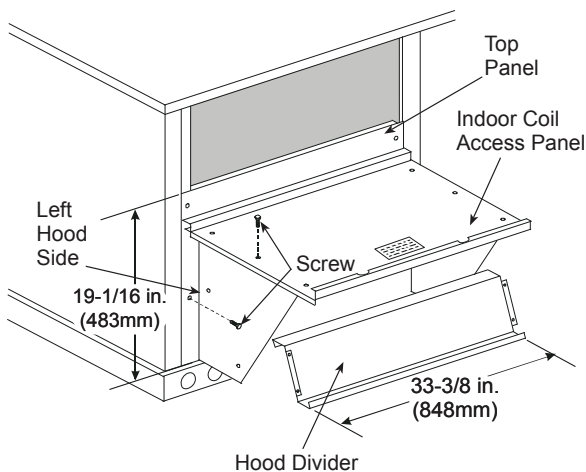

Fig. 12 – Economizer Hood Construction

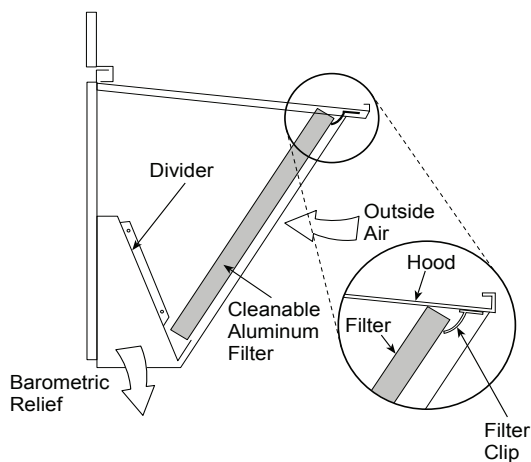

Fig. 13 – Economizer Filter Installation

Step 9 – Units with Hinged Panels Only

If the unit does not have hinged panels, skip this step and continue at Step 10 below.

Relocate latch shipped inside the compressor compartment behind the hinged compressor door to location shown in Fig. 14 after unit installation.

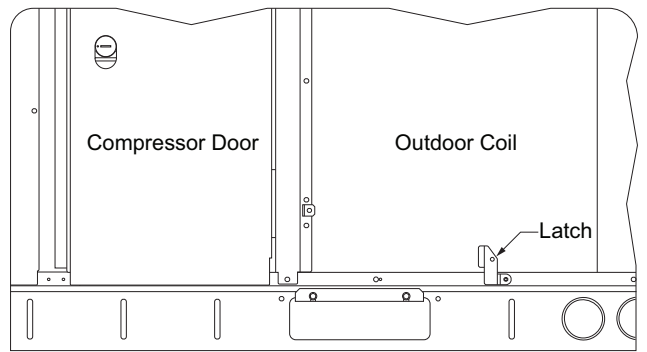

Fig. 14 – Compressor Door Latch Location

Step 10 – Install Flue Hood

Flue hood is shipped screwed to the basepan beside the burner compartment access panel. Remove from shipping location and using screws provided, install flue hood and screen in location shown in Fig. 15.

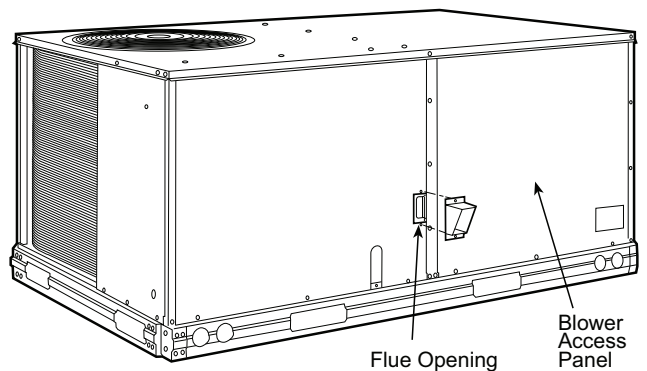

Fig. 15 – Flue Hood Details

Step 11 – Install Gas Piping

Installation of the gas piping must be accordance with local building codes and with applicable national codes. In U.S.A., refer to NFPA 54/ANSI Z223.1 National Fuel Gas Code (NFGC). In Canada, installation must be accordance with the CAN/CSA B149.1 and CAN/CSA B149.2 installation codes for gas burning appliances.

This unit is factory equipped for use with Natural Gas (NG) fuel at elevations up to 7,800 ft (2377 m) above sea level.

Furnace gas input rate on rating plate is for installation up to 7,800 ft (2377 m) above sea level.

CAUTION

Units cannot operated at altitudes greater than 7,800 feet above mean sea level (AMSL) under any circumstances.

Gas pressure at unit gas connection must not be less than 4 in. wg (0.996 kPa) or greater than 13 in. wg (3.23 kPa) while the unit is operating. See Table 3.

Table 3 – Natural Gas Supply Line Pressure Ranges

UNIT MODEL	UNIT SIZE	MINIMUM	MAXIMUM
48FEG/H	04, 05, 06	4.0 in. wg (996 Pa)	13.0 in. wg (3240 Pa)

The gas supply pipe enters the unit at the burner access panel on the front side of the unit, through the long slot at the bottom of the access panel. The gas connection to the unit is made to the 1/2 in. FPT gas inlet port on the unit gas valve.

Manifold pressure is factory-adjusted for natural gas fuel use. See Table 4.

Table 4 — Natural Gas Manifold Pressure Ranges

UNIT MODEL	UNIT SIZE	HIGH FIRE	LOW FIRE
48FEG/H	04, 05, 06	3.5 in. wg (872 Pa)	1.7 in. wg (423 Pa)

⚠ CAUTION

EQUIPMENT DAMAGE

Failure to follow this caution may result in equipment damage. When connecting the gas line to the unit gas valve, the installer **MUST** use a backup wrench to prevent damage to the valve.

Install a gas supply line that runs to the unit heating section. Refer to the NFPA 54/NFPA or equivalent code for gas pipe sizing data. Do not use a pipe size smaller than 1/2 inch. Size the gas supply line to allow for a maximum pressure drop of 0.5 in. wg (124 Pa) between gas regulator source and unit gas valve connection when unit is operating at high-fire flow rate.

The gas supply line can approach the unit in 3 ways: horizontally from outside the unit (across the roof), thru-curb/under unit basepan (accessory kit required), or through unit basepan (factory option or accessory kit required). Consult accessory kit installation instructions for details on these installation methods. Observe clearance to gas line components per Fig. 16.

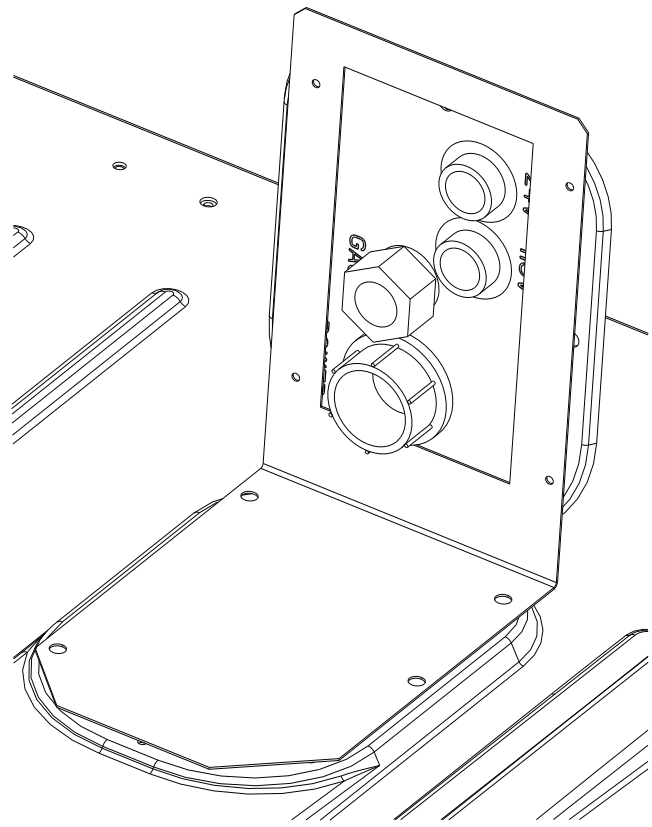
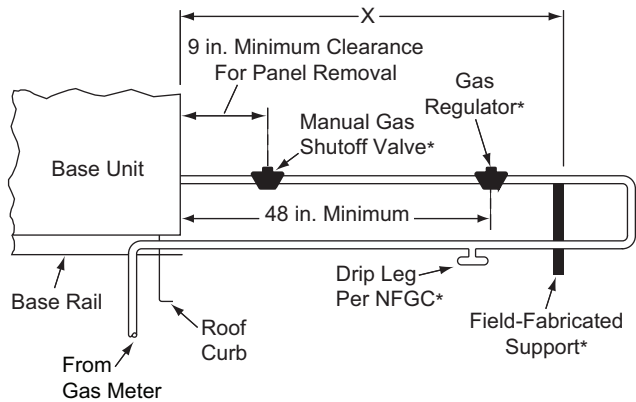

Fig. 17 — Thru-the-Base Fitting Assembly (Shown in Shipping Position)



LEGEND

NFGC — National Fuel Gas Code

NOTE: Follow all local codes.

*Field-installed.

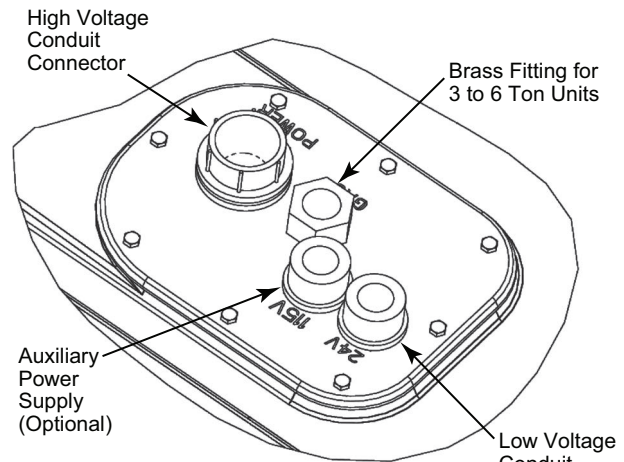

Fig. 18 — Thru-Base Connection Fittings

STEEL PIPE NOMINAL DIAMETERS (in.)	SPACING OF SUPPORTS X DIMENSION (ft)
1/2	6
3/4 or 1	8
1-1/4 or larger	10

Fig. 16 — Gas Piping Guide (with Accessory Thru-the-Curb Service Connections)

FACTORY OPTION THRU-BASE CONNECTIONS (GAS CONNECTIONS)

This service connection kit consists of a 1/2 in. electrical bulkhead connector and a 3/4 in. electrical bulkhead connector, connected to an “L” bracket covering the embossed (raised) section of the unit basepan in the condenser section (see Fig. 17 for shipping position).

The 3/4 in. bulkhead connector enables the low-voltage control wires to pass through the basepan. The 1/2 in. bulkhead connector allows the high-voltage power wires to pass through the basepan. See Fig. 18.

To prepare the unit for thru-base connections:

1. Remove the “L” bracket assembly from the unit.
2. Remove connector plate assembly from the “L” bracket and discard the “L” bracket, but retain the washer head screws and the gasket (located between the “L” bracket and the connector plate assembly).

NOTE: Take care not to damage the gasket, as it is reused in the following step.

3. Place the gasket over the embossed area in the basepan, aligning the holes in the gasket to the holes in the basepan. See Fig. 18.
4. Install the connector plate assembly to the basepan using 8 of the washer head screws.

The thru-base gas connector has male and female threads. The male threads protrude above the basepan of the unit; the female threads protrude below the basepan.

Check tightness of connector lock nuts before connecting gas piping.

Install a 1/2 in. NPT street elbow on the thru-base gas fitting. Attach a 1/2 in. pipe nipple with minimum length of 16 in. (406 mm) (field-supplied) to the street elbow and extend it through the access panel at the gas support bracket. See Fig. 19.

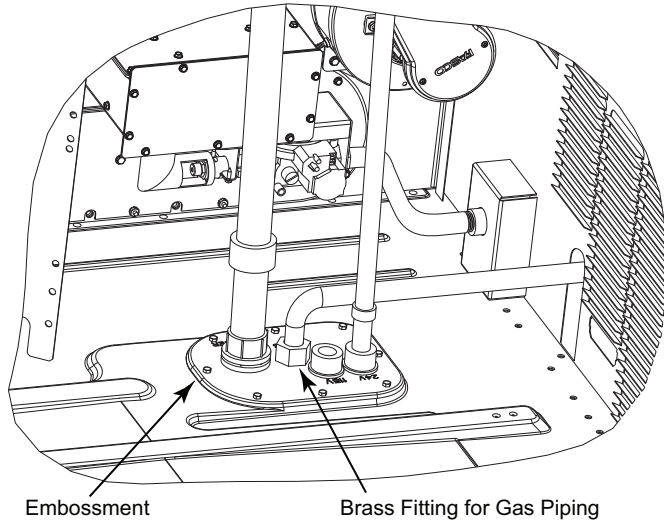

Fig. 19 — Gas Line Piping

Other hardware required to complete the installation of the gas supply line includes a manual shutoff valve, a sediment trap (drip leg) and a ground-joint union. A pressure regulator valve may also be required (to convert gas pressure from pounds to inches of pressure). The manual shutoff valve must be located within 6 ft (1.83 m) of the unit. The union, located in the final leg entering the unit, must be located at least 9 in. (230 mm) away from the access panel to permit the panel to be removed for service. If a regulator valve is installed, it must be located a minimum of 4 ft (1220 mm) away from the unit's flue outlet. Some municipal codes require that the manual shutoff valve be located upstream of the sediment trap. See Fig. 20 and 21 for typical piping arrangements for gas piping that has been routed through the sidewall of the curb. See Fig. 22 for typical piping arrangement when thru-base is used. Ensure that all piping does not block access to the unit's main control box or limit the required working space in front of the control box.

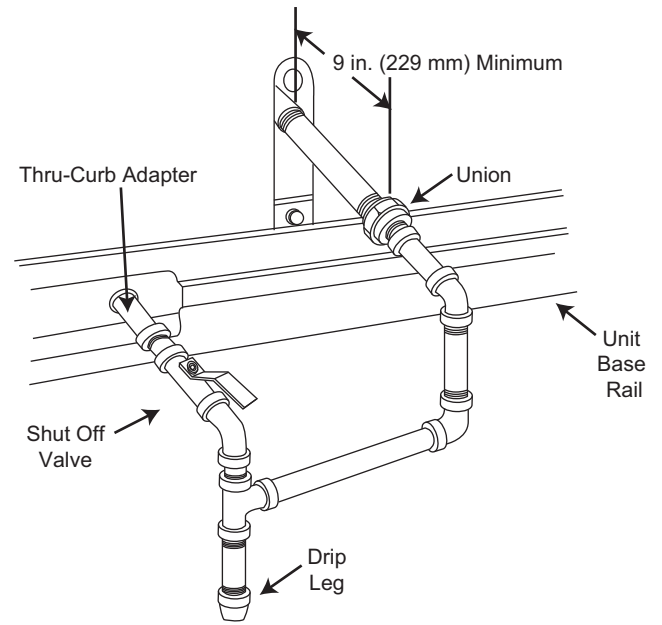

Fig. 20 — Gas Piping, Typical Curb Sidewall Piping (Example 1)

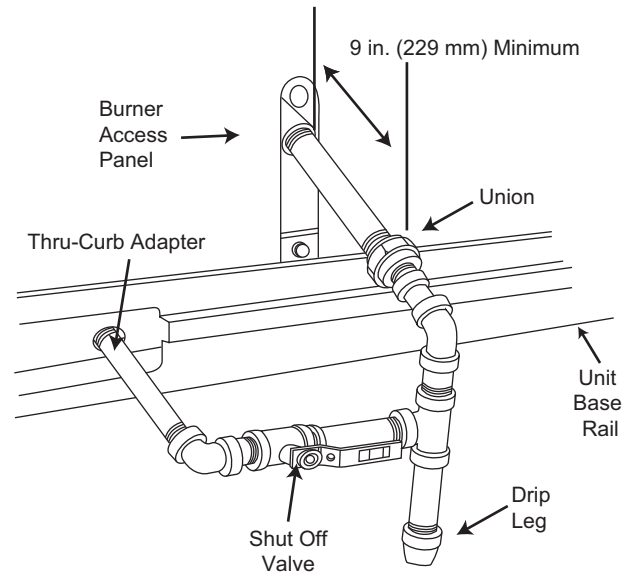

Fig. 21 — Gas Piping, Typical Curb Sidewall Piping (Example 2)

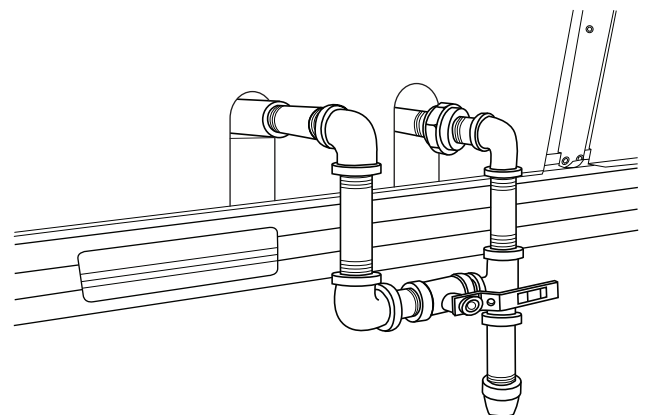

Fig. 22 — Gas Piping, Typical Thru-Base Connections

When installing the gas supply line, observe local codes pertaining to gas pipe installations. Refer to the NFPA 54/ANSI Z223.1 NFGC latest edition (in Canada, CAN/CSA B149.1). In the absence of local building codes, adhere to the following pertinent recommendations:

- Avoid low spots in long runs of pipe. Grade all pipe 1/4 in. per every 15 ft (7 mm per every 5 m) to prevent traps. Grade all horizontal runs downward to risers. Use risers to connect to heating section and to meter.
- Protect all segments of piping system against physical and thermal damage. Support all piping with appropriate straps, hangers, etc. Use a minimum of one hanger every 6 ft (1.8 m). For pipe sizes larger than 1/2 in., follow recommendations of national codes.
- Apply joint compound (pipe dope) sparingly and only to male threads of joint when making pipe connections. Use only pipe dope that is resistant to action of liquefied petroleum gases as specified by local and/or national codes. If using PTFE (Teflon[®]) tape, ensure the material is Double Density type and is labeled for use on gas lines. Apply tape per manufacturer's instructions.
- Pressure-test all gas piping in accordance with local and national plumbing and gas codes before connecting piping to unit.

NOTE: Pressure test the gas supply system after the gas supply piping is connected to the gas valve. The supply piping must be disconnected from the gas valve during the testing of the piping systems when test pressure is in excess of 0.5 psig (3450 Pa). Pressure test the gas supply piping system at pressures equal to or less than 0.5 psig (3450 Pa). The unit heating section must be isolated from the gas piping system by closing the external main manual shutoff valve and slightly opening the ground-joint union.

Check for gas leaks at the field-installed and factory-installed gas lines after all piping connections have been completed. Use soap-and-water solution (or method specified by local codes and/or regulations).

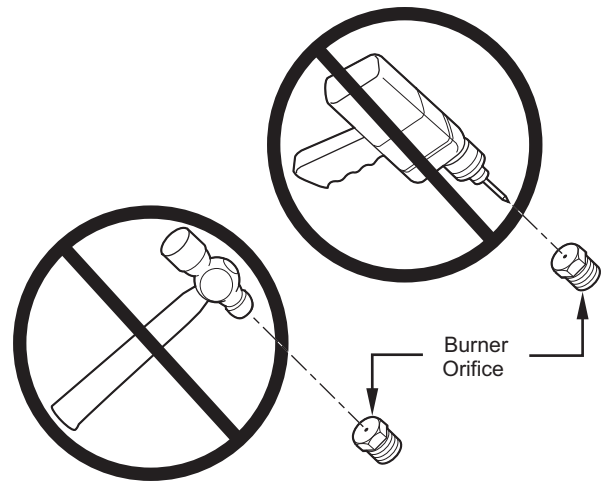

Fig. 23 — Orifice Hole

⚠ WARNING

Failure to follow this warning could result in personal injury, death and/or property damage.

- Connect gas pipe to unit using a backup wrench to avoid damaging gas controls.
- Never purge a gas line into a combustion chamber.
- Never test for gas leaks with an open flame. Use a commercially available soap solution made specifically for the detection of leaks to check all connections.
- Use proper length of pipe to avoid stress on gas control manifold.

NOTE: If orifice hole appears damaged or it is suspected to have been redrilled, check orifice hole with a numbered drill bit of correct size. Never redrill an orifice. A burr-free and squarely aligned orifice hole is essential for proper flame characteristics. See Fig. 23.

⚠ ATTENTION

After the installation of the unit gas piping and prior to gas heat start up, ensure that the distances between the main burner orifice and the burner box inlet tube meet those shown below. If not, loosen the orifice alignment screw on the bracket shown, slide the assembly to meet those distances then tighten the screw to secure the gas orifice assembly.

Front View — Gas Assembly and Burner Box

Detail A

Gas Heat Model	A	B
48FEG (Low Heat)	11/16 in. (17.4 mm)	7/16 in. (11.1 mm)
48FEH (Med Heat)	5/16 in. (8.0 mm)	7/16 in. (11.1 mm)

1. Third-party trademarks and logos are the property of their respective owners.

Step 12 — Install External Condensate Trap and Line

The unit has one 3/4 in. condensate drain connection on the end of the condensate pan and an alternate connection on the bottom. See Fig. 24. Unit airflow configuration does not determine which drain connection to use. Either drain connection can be used with vertical or horizontal applications.

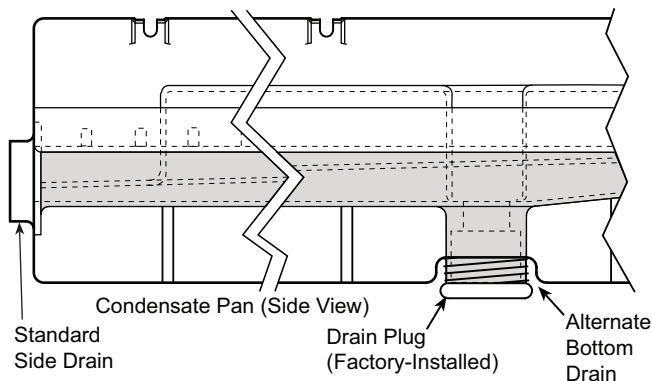

Fig. 24 — Condensate Drain Pan (Side View)

When using the standard side drain connection, ensure the red plug in the alternate bottom connection is tight. Do this before setting the unit in place. The red drain pan can be tightened with a 1/2 in. square socket drive extension.

To use the alternate bottom drain connection, remove the red drain plug from the bottom connection (use a 1/2 in. square socket drive extension) and install it in the side drain connection.

The piping for the condensate drain and external trap can be completed after the unit is in place. See Fig. 25.

All units must have an external trap for condensate drainage. Install a trap at least 4 in. (102 mm) deep and protect against freeze-up. If drain line is installed downstream from the external trap, pitch the line away from the unit at 1 in. per 10 ft (25 mm per 3 m) of run. Do not use a pipe size smaller than the unit connection (3/4 in.).

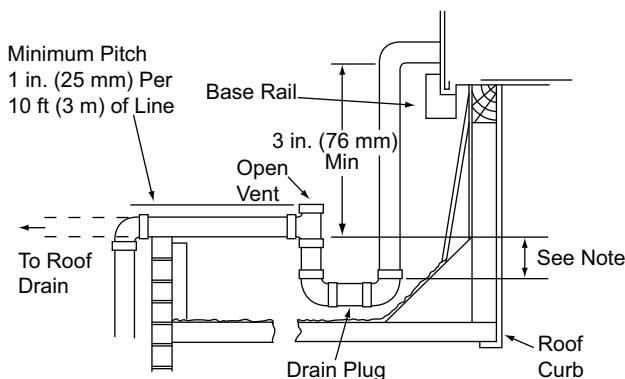

NOTE: Trap should be deep enough to offset maximum unit static difference. A 4 in. (102 mm) trap is recommended.

Fig. 25 — Condensate Drain Pan Piping Details

Step 13 — Make Electrical Connections

⚠ WARNING

Failure to follow this warning could result in personal injury or death.

Do not use gas piping as an electrical ground.

Unit cabinet must have an uninterrupted, unbroken electrical ground to minimize the possibility of personal injury if an electrical fault should occur. This ground may consist of electrical wire connected to unit ground lug in control compartment, or conduit approved for electrical ground when installed in accordance with NEC (National Electrical Code); ANSI/NFPA 70, latest edition (in Canada, Canadian Electrical Code CSA [Canadian Standards Association] C22.1), and local electrical codes.

NOTE: Field-supplied wiring shall conform with the limitations of minimum 63°F (33°C) rise.

FIELD POWER SUPPLY

If equipped with optional powered convenience outlet: the power source leads to the convenience outlet's transformer primary are not factory connected. Installer must connect these leads according to required operation of the convenience outlet. If an always-energized convenience outlet operation is desired, connect the source leads to the line side of the unit-mounted disconnect. (Check with local codes to ensure this method is acceptable in your area.) If a de-energize via unit disconnect switch operation of the convenience outlet is desired, connect the source leads to the load side of the unit disconnect. On a unit without a unit-mounted disconnect, connect the source leads to compressor contactor C pressure lugs with unit field power leads. See Convenience Outlets on page 19 for power transformer connections.

The field power wires are connected to the unit at line-side pressure lugs on compressor contactor C (see wiring diagram label for control box component arrangement) or at factory-installed optional non-fused disconnect switch or HACR (Heating, Air Conditioning, and Refrigeration). Maximum wire size is No. 2ga AWG (copper only) per pole on contactors and No. 2ga AWG (copper only) per pole on optional disconnect or HACR. See Fig. 26 and unit label diagram for field power wiring connections.

NOTE: Unit may be equipped with short test leads (pigtails) on the field line connection points on contactor C or optional disconnect switch. These leads are for factory-run test purposes only; remove and discard before connecting field power wires to unit connection points. Make field power connections directly to line connection pressure lugs only. See Fig. 27.

⚠ WARNING

FIRE HAZARD

Failure to follow this warning could result in personal injury, death, or property damage.

Do not connect aluminum wire between disconnect switch and unit. Use only copper wire.

Units Without Non-Fused Disconnect Option

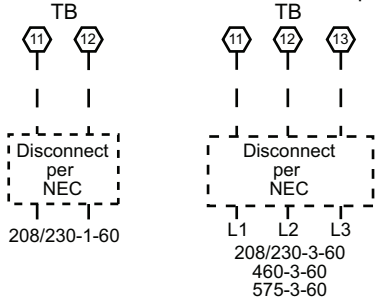

Units With Non-Fused Disconnect Option

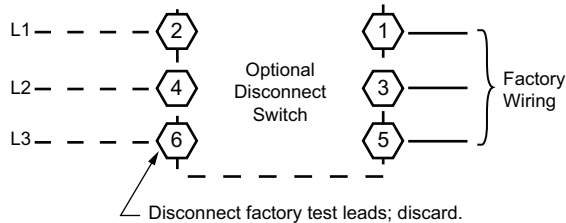

Fig. 26 — Power Wiring Connections

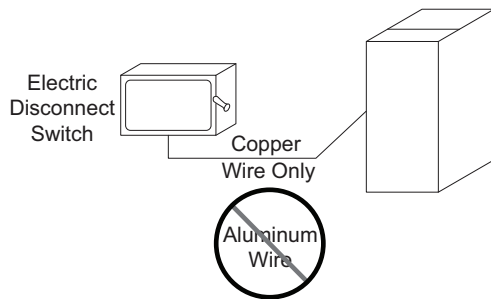

Fig. 27 — Disconnect Switch and Unit

UNITS WITH FACTORY-INSTALLED NON-FUSED DISCONNECT

The factory-installed option non-fused disconnect (NFD) switch is located in a weatherproof enclosure located under the main control box. The manual switch handle and shaft are shipped in the disconnect enclosure. Assemble the shaft and handle to the switch at this point. Discard the factory test leads (see Fig. 26).

Connect field power supply conductors to LINE side terminals when the switch enclosure cover is removed to attach the handle.

Field-Install the NFD Shaft and Handle

1. Remove the Control Box access panel. The NFD enclosure is located below the Control Box (see Fig. 28).
2. Remove 3 cap head screws that secure the NFD enclosure front cover — 2 on the face of the cover and 1 on the left side cover. See Fig. 29.
3. Remove the front cover of the NFD enclosure.
4. Make sure the NFD shipped from the factory is at OFF position (the arrow on the black handle knob is at OFF).
5. Insert the shaft with the cross pin on the top of the shaft in the horizontal position. See Fig. 29.
6. Measure from the tip of the shaft to the top surface of the black pointer; the measurement should be 3.75 to 3.88 in. (95 to 99 mm).
7. Tighten the locking screw to secure the shaft to the NFD.
8. Turn the handle to the OFF position with red arrow pointing at OFF.

9. Install the handle on to the painted cover horizontally with the red arrow pointing to the left.
10. Secure the handle to the painted cover with 2 screws and lock washers supplied.
11. Engaging the shaft into the handle socket, re-install 3 hex screws on the NFD enclosure.
12. Re-install the unit front panel.

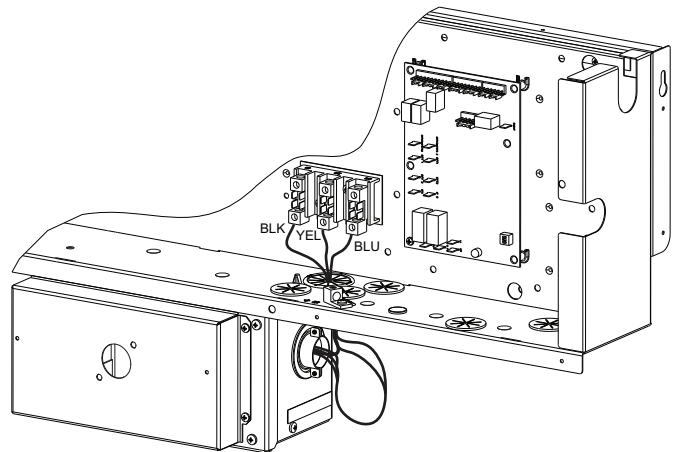

Fig. 28 — NFD Enclosure Location

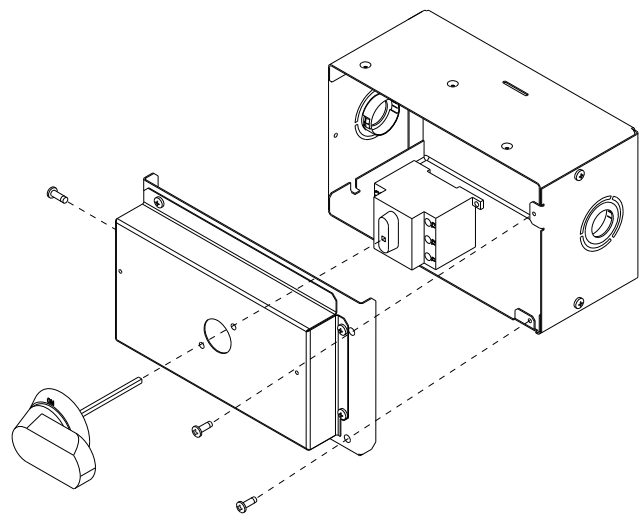

Fig. 29 — NFD Handle and Shaft Assembly

UNITS WITHOUT FACTORY-INSTALLED NON-FUSED DISCONNECT

When installing units, provide a disconnect switch per NEC (National Electrical Code) of adequate size. Disconnect sizing data is provided on the unit informative plate. Locate on unit cabinet or within sight of the unit per national or local codes. Do not cover unit informative plate if mounting the disconnect on the unit cabinet.

ALL UNITS

All field wiring must comply with NEC and all local codes. Size wire based on MCA (Minimum Circuit Amps) on the unit informative plate. See Fig. 26 and the unit label diagram for power wiring connections to the unit power terminal blocks and equipment ground. Maximum wire size is No. 2ga AWG (copper only) per pole on contactors. See Fig. 26 and unit label diagram for field power wiring connections.

Provide a ground fault and short circuit over-current protection device (fuse or breaker) per NEC Article 440 (or local codes). Refer to unit informative data plate for MOCP (Maximum Over-Current Protection) device size.

All units except 208/230-v units are factory wired for the voltage shown on the nameplate. *If the 208/230-v unit is to be connected to a 208-v power supply, the control transformer must be rewired by moving the black wire with the 1/4 in. female spade connector from the 230-v connection and moving it to the 200-v 1/4 in. male terminal on the primary side of the transformer. Refer to unit label diagram for additional information. Field power wires will be connected at line-side pressure lugs on the power terminal block or at factory-installed option non-fused disconnect.*

Voltage to compressor terminals during operation must be within voltage range indicated on unit nameplate. On 3-phase units, voltages between phases must be balanced within 2% and the current within 10%. Use the formula shown in the following example to determine the percent of voltage imbalance. Operation on improper line voltage or excessive phase imbalance constitutes abuse and may cause damage to electrical components. Such operation would invalidate any applicable Carrier warranty.

$$\% \text{ Voltage Imbalance} = 100 \times \frac{\text{max voltage deviation from average voltage}}{\text{average voltage}}$$

Example: Supply voltage is 230-3-60

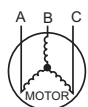

AB = 224-v
BC = 231-v
AC = 226-v

$$\text{Average Voltage} = \frac{(224 + 231 + 226)}{3} = \frac{681}{3} = 227$$

Determine maximum deviation from average voltage.

(AB) 227-224 = 3-v

(BC) 231-227 = 4-v

(AC) 227-226 = 1-v

Maximum deviation is 4-v.

Determine percent of voltage imbalance.

$$\% \text{ Voltage Imbalance} = 100 \times \frac{4}{227} = 1.76\%$$

This amount of phase imbalance is satisfactory as it is below the maximum allowable 2%.

IMPORTANT: If the supply voltage phase imbalance is more than 2%, contact your local electric utility company immediately.

CONVENIENCE OUTLETS

⚠ WARNING

ELECTRICAL OPERATION HAZARD

Failure to follow this warning could result in personal injury or death.

Units with convenience outlet circuits may use multiple disconnects. Check convenience outlet for power status before opening unit for service. Locate its disconnect switch, if appropriate, and open it. Lock-out and tag-out this switch, if necessary.

Two types of convenience outlets are offered on 48FE(G/H) models: non-powered and unit-powered. Both types provide a 125-v GFCI (ground-fault circuit interrupter) duplex receptacle rated at 15A behind a hinged waterproof access cover, located on the end panel of the unit. See Fig. 30.

Figure 31 shows the Convenience Outlet Utilization label, which is located below the convenience outlet.

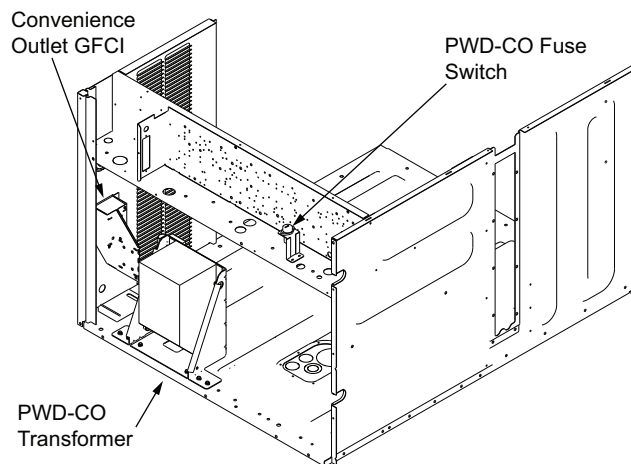

Fig. 30 – Convenience Outlet Location

NOTICE

Convenience Outlet Utilization

Maximum Continuous use: 15 Amps for receptacle outlets, and 8 Amps for factory supplied transformers

50HJ542739 C

Fig. 31 – Convenience Outlet Utilization Notice Label

NOTE: Unit powered convenience outlets are not available as factory-installed options for single phase (-3 voltage code models).

Installing Weatherproof Cover

A weatherproof while-in-use cover for the factory-installed convenience outlets is now required by UL standards. This cover cannot be factory-mounted due its depth; it must be installed at unit installation. For shipment, the convenience outlet is covered with a blank cover plate.

On units with electromechanical controls the weatherproof cover kit is shipped in the unit's control box. The kit includes the hinged cover, a backing plate, and gasket. On units with a factory installed direct digital controller (DDC; SystemVu™) the weatherproof cover kit is secured to the basepan underneath the control box (see Fig. 32).

⚠ WARNING

ELECTRICAL OPERATION HAZARD

Failure to follow this warning could result in personal injury or death.

Using unit-mounted convenience outlets: Units with unit-mounted convenience outlet circuits will often require that two disconnects be opened to de-energize all power to the unit. Treat all units as electrically energized until the convenience outlet power is also checked and de-energization is confirmed. Observe National Electrical Code Article 210, Branch Circuits, for use of convenience outlets.

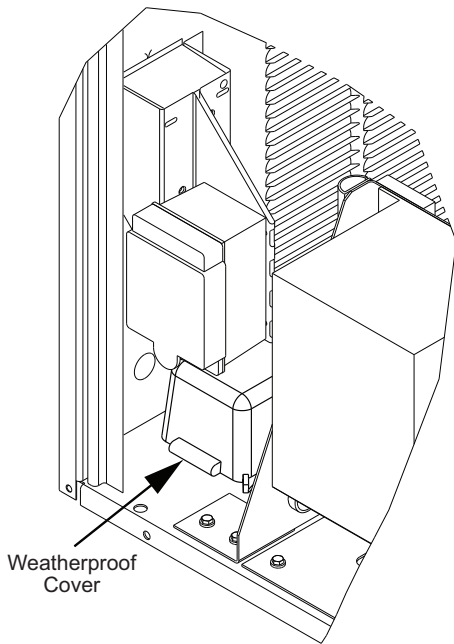

Fig. 32 — Weatherproof Cover — Shipping Location on Units with Factory Installed DDC (Direct Digital Controller)

1. Remove the blank cover plate at the convenience outlet; discard the blank cover.
2. Loosen the 2 screws at the GFCI duplex outlet, until approximately 1/2 in. (13 mm) under screw heads is exposed. Press the gasket over the screw heads.
3. Slip the backing plate over the screw heads at the keyhole slots and align with the gasket; tighten the 2 screws until snug (do not over-tighten).
4. Mount the weatherproof cover to the backing plate as shown in Fig. 33.
5. Remove 2 slot fillers in the bottom of the cover to permit service tool cords to exit the cover.
6. Check for full closing and latching.

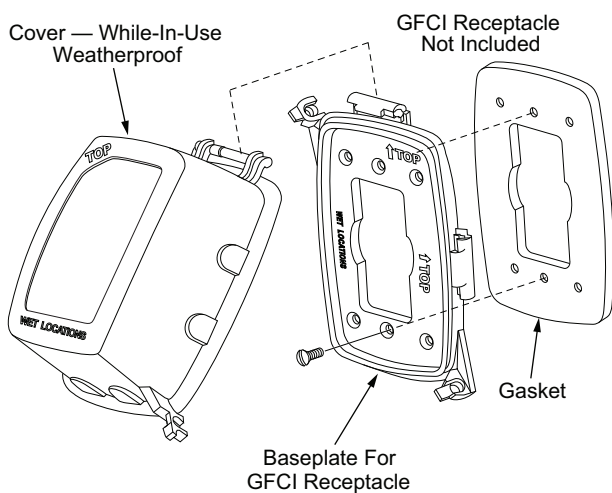

Fig. 33 — Weatherproof Cover Installation

Non-Powered Convenience Outlet

This type requires the field installation of a general-purpose 125-v 15A circuit powered from a source elsewhere in the building. Observe national and local codes when selecting wire size, fuse or breaker requirements, and disconnect switch size and location.

Route 125-v power supply conductors into the bottom of the utility box containing the duplex receptacle.

Unit-Powered Convenience Outlet

A unit-mounted transformer is factory-installed to step down the main power supply voltage to the unit to 115-v at the duplex receptacle. This option also includes a manual switch with fuse, located in a utility box and mounted on a bracket behind the convenience outlet; access is through the unit's control box access panel. See Fig. 30.

The primary leads to the convenience outlet transformer are not factory-connected. Selection of primary power source is a customer option. If local codes permit, the transformer primary leads can be connected at the line-side terminals on the unit-mounted non-fused disconnect switch; this will provide service power to the unit when the unit disconnect switch is open. Other connection methods will result in the convenience outlet circuit being de-energized when the unit disconnect switch is open. See Fig. 34.

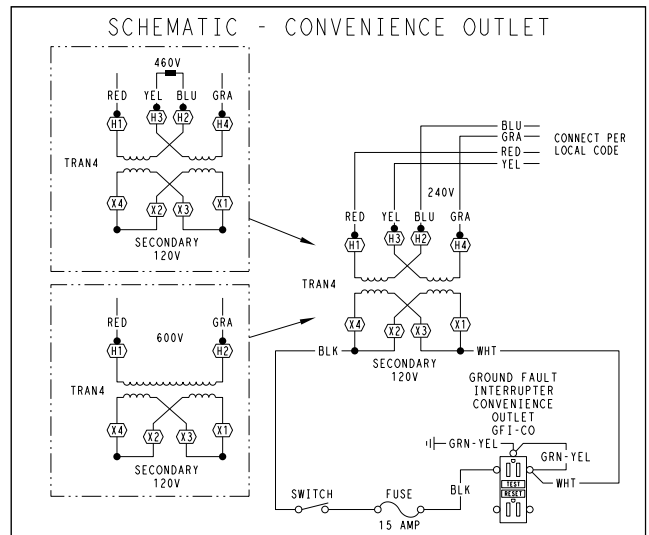

UNIT VOLTAGE	CONNECT AS	PRIMARY CONNECTIONS	TRANSFORMER TERMINALS
208, 230	240	L1: RED + YEL L2: BLU + GRA	H1 + H3 H2 + H4
460	480	L1: RED L2: Splice BLU + YEL + GRA	H1 H2 + H3 H4
575	600	L1: RED L2: GRA	H1 H2

Fig. 34 — Powered Convenience Outlet Wiring

Fuse On Power Type

The factory fuse is a Bussmann™^{TM1} Fusetron™^{TM1} T-15, non-renewable screw-in (Edison base) type plug fuse.

Test the GFCI receptacle by pressing the TEST button on the face of the receptacle to trip and open the receptacle. Check for proper grounding wires and power line phasing if the GFCI receptacle does not trip as required. Press the RESET button to clear the tripped condition.

Using Unit-Mounted Convenience Outlets

Units with unit-mounted convenience outlet circuits will often require that 2 disconnects be opened to de-energize all power to the unit. Treat all units as electrically energized until the convenience outlet power is also checked and de-energization is confirmed. Observe National Electrical Code Article 210, Branch Circuits, for use of convenience outlets.

1. Third-party trademarks and logos are the property of their respective owners.

FACTORY-OPTION THRU-BASE CONNECTIONS (ELECTRICAL CONNECTIONS)

This service connection kit consists of a 1/2 in. NPT gas adapter fitting (brass), a 1/2 in. electrical bulkhead connector, and a 3/4 in. electrical bulkhead connector, all factory-installed in the embossed (raised) section of the unit basepan in the condenser section. The 3/4 in. bulkhead connector enables the low-voltage control wires to pass through the basepan. The 1/2 in. electrical bulkhead connector allows the high-voltage power wires to pass through the basepan. See Fig. 18 on page 14.

NOTE: If electrical connections are not going to occur at this time, tape or otherwise cover the fittings so that moisture does not get into the building or conduit in the interim.

Check tightness of connector lock nuts before connecting electrical conduits.

Field-supplied and field-installed liquid tight conduit connectors and conduit may be attached to the connectors on the basepan. Pull correctly rated high voltage and low voltage through appropriate conduits. Connect the power conduit to the internal disconnect (if unit is so equipped) or to the external disconnect (through unit side panel). A hole must be field cut in the main control box bottom on the left side so the 24-v control connections can be made. Connect the control power conduit to the unit control box at this hole.

UNITS WITHOUT THRU-BASE CONNECTIONS (ELECTRICAL CONNECTIONS)

1. Install power wiring conduit through side panel openings. Install conduit between disconnect and control box.
2. Install power lines to terminal connections as shown in Fig. 26 on page 18.

FIELD CONTROL WIRING

The 48FE(G/H) unit requires an external temperature control device. This device can be a thermostat (field-supplied) or a SystemVu™ controller (available as factory-installed option for use on a Carrier Comfort Network® or as a stand-alone control). All field added wire must comply with UL and local NEC standards.

THERMOSTAT

Install a Carrier-approved accessory thermostat according to installation instructions included with the accessory. For complete economizer function, select a 2-stage cooling thermostat. Locate the thermostat accessory on a solid wall in the conditioned space to sense average temperature in accordance with the thermostat installation instructions. Typical low-voltage connections are shown in Fig. 35.

If the thermostat contains a logic circuit requiring 24-v power, use a thermostat cable or equivalent single leads of different colors with minimum of 7 leads. If the thermostat does not require a 24-v source (no “C” connection required), use a thermostat cable or equivalent with minimum of 6 leads. Check the thermostat installation instructions for additional features which might require additional conductors in the cable.

For wire runs up to 50 ft (15 m), use No. 18 AWG (American Wire Gauge) insulated wire [95°F (35°C) minimum]. For 50 to 75 ft (15 to 23 m), use No. 16 AWG insulated wire [95°F (35°C) minimum]. For over 75 ft (23 m), use No. 14 AWG insulated wire [95°F (35°C) minimum]. Wire sizes larger than No. 18 AWG cannot be directly connected to the thermostat and will require a junction box and splice at the thermostat.

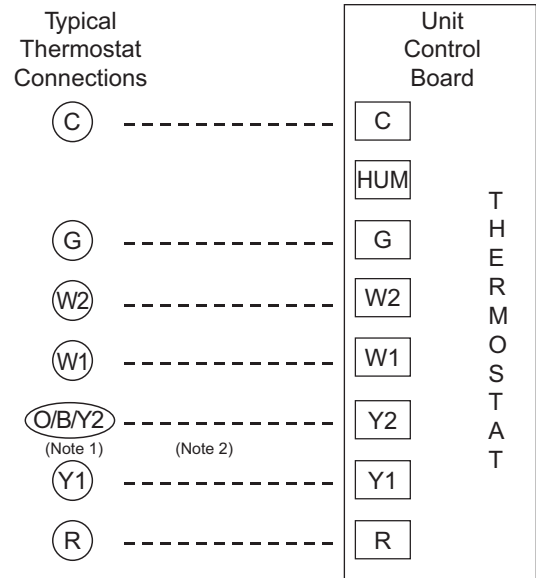

Note 1: Typical multi-function marking. Follow manufacturer's configuration Instructions to select Y2.

Note 2: Y2 to Y2 connection required on single-stage cooling units when integrated economizer function is desired.

--- Field Wiring

Fig. 35 — Low-Voltage Thermostat Connections

Thermostat Wiring, Units Without Thru-Base Connection Kit

Pass the thermostat control wires through the hole provided in the corner post; then feed the wires through the raceway built into the corner post to the control box. Pull the wires over to the terminal strip on the upper-left corner of the Unit Control Board. See Fig. 36.

NOTE: If thru-the-bottom connections accessory is used, refer to the accessory installation instructions for information on routing power and control wiring.

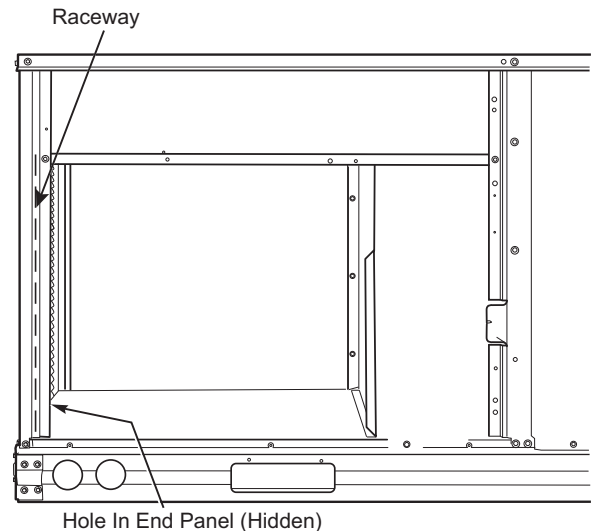

Fig. 36 — Field Control Wiring Raceway

HEAT ANTICIPATOR SETTINGS

Set heat anticipator settings at 0.14 amp for the first stage and 0.14 amp for second-stage heating, when available.

HUMIDI-MIZER® CONTROL CONNECTIONS

Humidi-MiZer Space RH Controller

NOTE: The Humidi-MiZer system is a factory-installed option. Humidi-MiZer system is not available for single phase (-3 voltage code) models.

The Humidi-MiZer dehumidification system requires a field-supplied and field-installed space relative humidity control device. This device may be a separate humidistat control (contact closes on rise in space RH above control set point) or a combination thermostat-humidistat control device such as Carrier's Edge® Pro Thermidistat™ device with isolated contact set for dehumidification control. See Fig. 37 and Fig. 38. The humidistat is normally used in applications where a temperature control is already provided (units with SystemVu™ control).

Connecting the Carrier Humidistat (HL38MG029)

1. Route the humidistat 2-conductor cable (field-supplied) through the hole provided in the unit corner post.
2. Feed wires through the raceway built into the corner post (see Fig. 36) to the 24-v barrier located on the left side of the control box. The raceway provides the UL-required clearance between high-voltage and low-voltage wiring.
3. Connect one of the leads from the 2-conductor cable to the HUM terminal on the UCB (Unit Control Board). Connect the other lead to the R terminal on the UCB. See Fig. 37.

Connecting the Thermidistat device (33CS2PPRH-01)

1. Route the Thermidistat multi-conductor thermostat cable (field-supplied) through the hole provided in the unit corner post.
2. Feed wires through the raceway built into the corner post (see Fig. 36) to the 24-v barrier located on the left side of

the control box. The raceway provides the UL-required clearance between high-voltage and low-voltage wiring.

3. The Thermidistat has dry contacts at terminals D1 and D2 for dehumidification operation (see Fig. 38). Connect D1 to the R terminal on the UCB. Connect D2 to the HUM terminal on the UCB. Refer to the installation instructions included with the Carrier Edge® Pro Thermidistat device for more information.

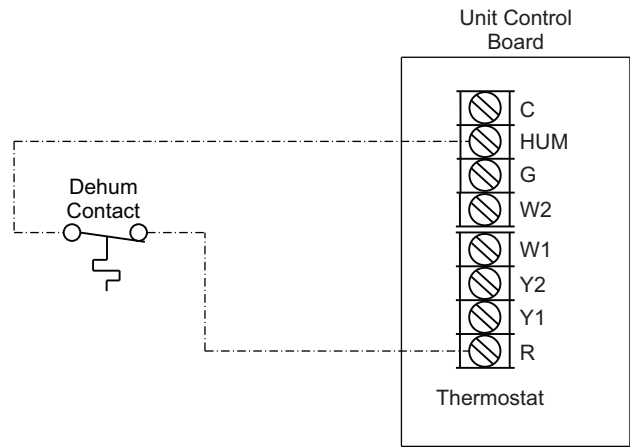

Fig. 37 — Humidistat Connections to UCB

TYPICAL UNIT WIRING DIAGRAMS

See Fig. 39-42 for examples of typical unit control and power wiring diagrams. These wiring diagrams are mounted on the inside of the unit control box cover.

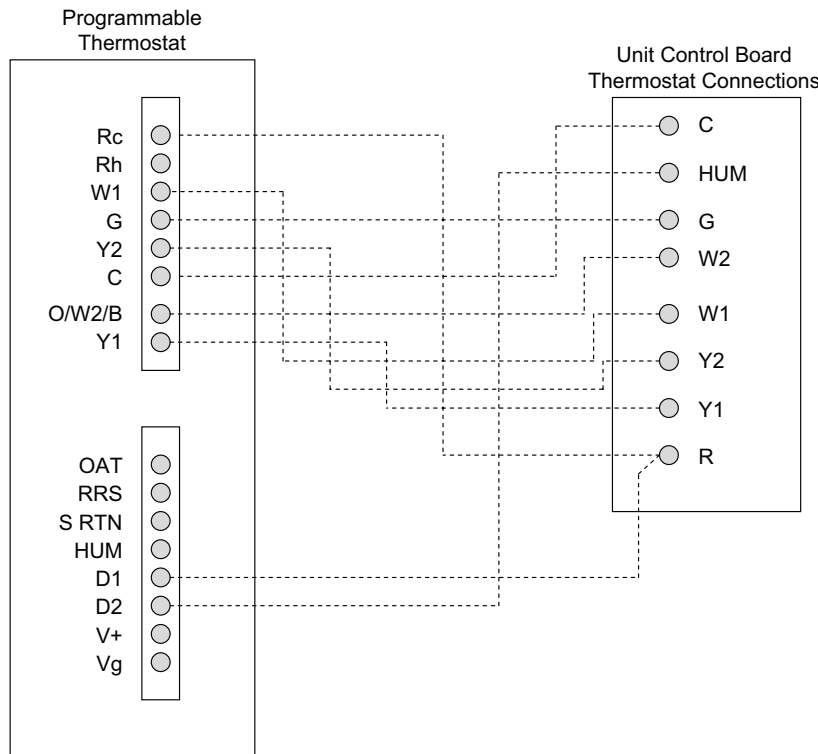

Fig. 38 — Typical Rooftop Unit with Humidi-MiZer Adaptive Dehumidification System and Edge® Pro Thermidistat Device

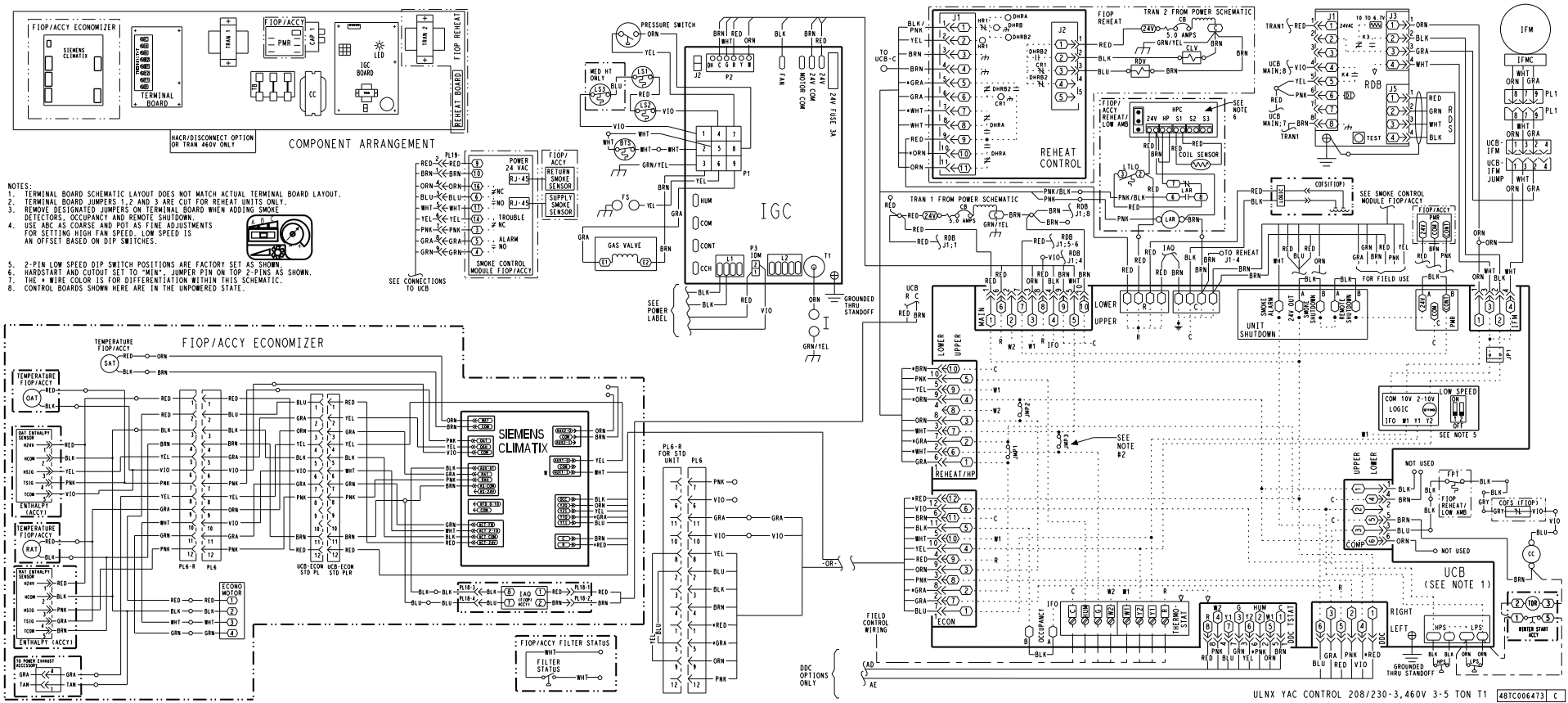

Fig. 39 — Typical 48FE(G/H) 04-06 Control Wiring Diagram, Electromechanical with POL224 EconomizerONE

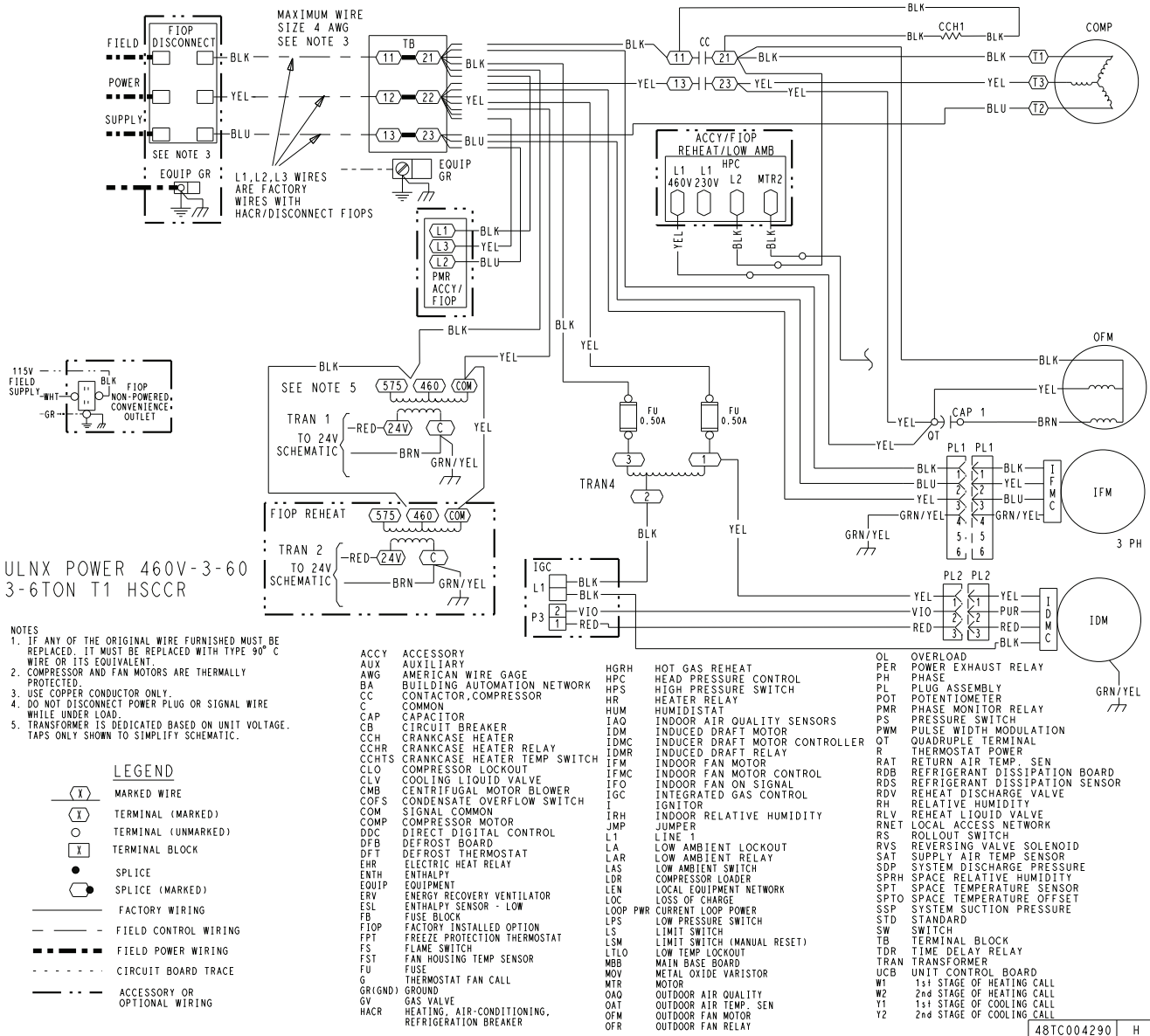

Fig. 40 — Typical 48FE(G/H) 04-06 Electromechanical Control Power Wiring Diagram, 460V Unit Shown

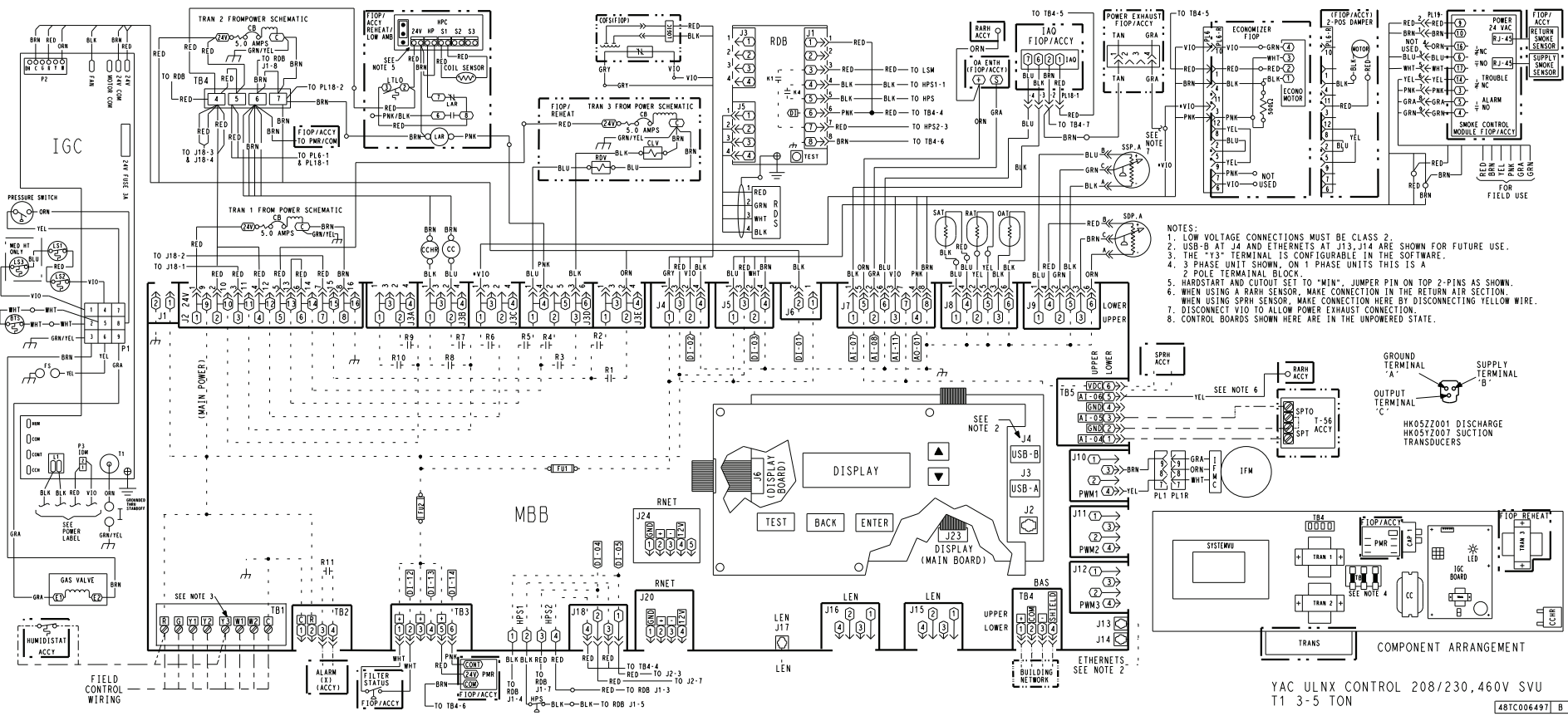
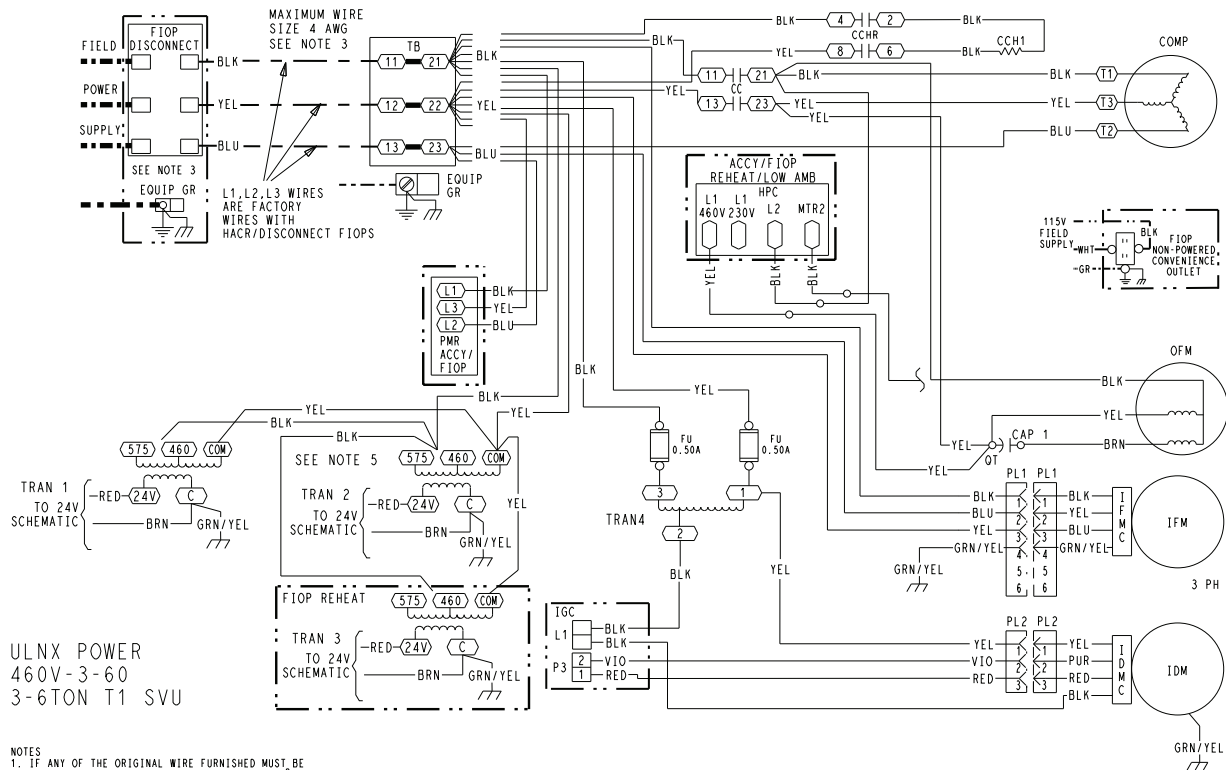

Fig. 41 — Typical 48FE(G/H) 04-06 SystemVu™ Control Wiring Diagram



- NOTES**
1. IF ANY OF THE ORIGINAL WIRE FURNISHED MUST BE REPLACED, IT MUST BE REPLACED WITH TYPE 90° C WIRE OR ITS EQUIVALENT.
 2. COMPRESSOR AND FAN MOTORS ARE THERMALLY PROTECTED.
 3. USE COPPER CONDUCTOR ONLY.
 4. DO NOT DISCONNECT POWER PLUG OR SIGNAL WIRE WHILE UNDER LOAD.
 5. TRANSFORMER IS DEDICATED BASED ON UNIT VOLTAGE. TAPS ONLY SHOWN TO SIMPLIFY SCHEMATIC.

- LEGEND**
- MARKED WIRE
 - TERMINAL (MARKED)
 - TERMINAL (UNMARKED)
 - TERMINAL BLOCK
 - SPLICE
 - SPLICE (MARKED)
 - FACTORY WIRING
 - FIELD CONTROL WIRING
 - FIELD POWER WIRING
 - CIRCUIT BOARD TRACE
 - ACCESSORY OR OPTIONAL WIRING

- | | | | | | |
|---------|--|----------|--------------------------------|------|----------------------------|
| ACCY | ACCESSORY | HGRH | HOT GAS REHEAT | OFR | OUTDOOR FAN RELAY |
| AUX | AUXILIARY | HPC | HEAD PRESSURE CONTROL | OL | OVERLOAD |
| AWG | AMERICAN WIRE GAUGE | HPS | HIGH PRESSURE SWITCH | PER | POWER EXHAUST RELAY |
| BA | BUILDING AUTOMATION NETWORK | HR | HEATER RELAY | PH | PHASE ASSEMBLY |
| CC | CONTACTOR, COMPRESSOR | HUM | HUMIDISTAT | PL | PLUG ASSEMBLY |
| CC | COMMON | I | IGNITOR | POT | POTENTIOMETER |
| CAP | CAPACITOR | IAQ | INDOOR AIR QUALITY SENSORS | PMR | PHASE MONITOR RELAY |
| CB | CIRCUIT BREAKER | IDM | INDUCED DRAFT MOTOR | PS | PRESSURE SWITCH |
| CCH | CRANKCASE HEATER | IDMC | INDUCED DRAFT MOTOR CONTROLLER | PWM | PULSE WIDTH MODULATION |
| CCHTS | CRANKCASE HEATER TEMP SWITCH | IDMR | INDUCED DRAFT RELAY | QT | QUADRUPLATE TERMINAL |
| CLO | COMPRESSOR LOCKOUT | IFM | INDOOR FAN MOTOR | R | THERMOSTAT POWER |
| CLV | COOLING LIQUID VALVE | IFMC | INDOOR FAN MOTOR CONTROL | RAT | RETURN AIR TEMP. SEN |
| CMB | CENTRIFUGAL MOTOR BLOWER | IFO | INDOOR FAN ON SIGNAL | RDV | RETURN AIR DISCHARGE VALVE |
| COFS | CONDENSATE OVERFLOW SWITCH | IGC | INTEGRATED GAS CONTROL | RH | RELATIVE HUMIDITY |
| COM | SIGNAL COMMON | I | IGNITOR | RLV | REHEAT LIQUID VALVE |
| COMP | COMPRESSOR MOTOR | IRH | INDOOR RELATIVE HUMIDITY | RNET | LOCAL ACCESS NETWORK |
| DDC | DIRECT DIGITAL CONTROL | JMP | JUMPER | RS | ROLLOUT SWITCH |
| DFB | DEFROST BOARD | LA | LOW AMBIENT LOCKOUT | RVS | REVERSING VALVE SOLENOID |
| DFT | DEFROST THERMOSTAT | LAR | LOW AMBIENT RELAY | SAT | SUPPLY AIR TEMP SENSOR |
| EHR | ELECTRIC HEAT RELAY | LAS | LOW AMBIENT SWITCH | SDP | SYSTEM DISCHARGE PRESSURE |
| ENTH | ENTHALPY | LBS | COMPRESSOR LOADER | SPRH | SPACE RELATIVE HUMIDITY |
| EQUIP | EQUIPMENT | LEN | LOCAL EQUIPMENT NETWORK | SPT | SPACE TEMPERATURE SENSOR |
| ERV | ENERGY RECOVERY VENTILATOR | LOC | LOSS OF CHARGE | SPTO | SPACE TEMPERATURE OFFSET |
| ESL | ENTHALPY SENSOR - LOW | LOC | LOSS OF CHARGE | SST | SYSTEM SUCTION PRESSURE |
| FB | FUSE BLOCK | LOOP PWR | CURRENT LOOP POWER | STD | STANDARD |
| FIOF | FACTORY INSTALLED OPTION | LPS | LOW PRESSURE SWITCH | SW | SWITCH |
| FPT | FREEZE PROTECTION THERMOSTAT | LS | LIMIT SWITCH | TB | TERMINAL BLOCK |
| FS | FLAME SWITCH | LSM | LIMIT SWITCH (MANUAL RESET) | TDR | TIME DELAY RELAY |
| FST | FAN HOUSING TEMP SENSOR | LTO | LOW TEMP LOCKOUT | TRAN | TRANSFORMER |
| FU | FUSE | MBB | MAIN BASE BOARD | UCB | UNIT CONTROL BOARD |
| G | THERMOSTAT FAN CALL | MOV | METAL OXIDE VARISTOR | W1 | 1st STAGE OF HEATING CALL |
| GR(GND) | GROUND | MTR | MOTOR | W2 | 2nd STAGE OF HEATING CALL |
| GV | GAS VALVE | OAO | OUTDOOR AIR QUALITY | Y1 | 1st STAGE OF COOLING CALL |
| HACR | HEATING, AIR-CONDITIONING, REFRIGERATION BREAKER | OAT | OUTDOOR AIR TEMP. SEN | Y2 | 2nd STAGE OF COOLING CALL |
| HGRH | HOT GAS REHEAT | OFM | OUTDOOR FAN MOTOR | | |

48TC004293 G

Fig. 42 — Typical 48FE(G/H) 04-06 SystemVu™ Control Power Wiring Diagram, 460V Unit Shown

Integrated Gas Controller

This unit contains an Integrated Gas Controller (IGC) board. The IGC control board uses a flue gas pressure switch that senses pressure drop in the heat exchanger due to the combustion inducer. See Fig. 43.

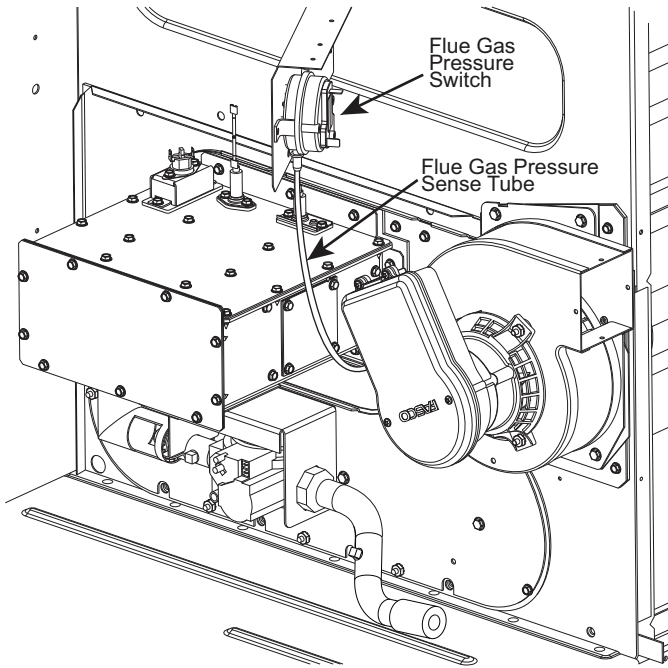

Fig. 43 — Flue Gas Pressure Switch and Pressure Sense Tube (Typical Location)

When the thermostat calls for heating, power is sent to W on the Integrated Gas Controller (IGC) board. An LED (light emitting diode) on the IGC board turns on and remains on during normal operation. A check is made to ensure that the rollout switch and limit switch are closed, and that the pressure switch is open. If the check was successful, the induced draft motor is energized. When the pressure in the heat exchanger is low enough to close the pressure switch, the ignition activation period begins. Once ignition occurs, the IGC board will continue to monitor the condition of the rollout switch, the limit switches, the pressure switch, and the flame sensor. Assuming the unit is controlled through a room thermostat set for "fan auto," 45 seconds after ignition occurs, the indoor fan motor will energize, and the outdoor air dampers will open to their minimum position. If the "over temperature limit" opens prior to the start of the indoor fan blower, the IGC will shut down the burners, and the control will shorten the 45 second delay to 5 seconds less than the time to trip the limit. For example, if the limit trips at 37 seconds, the control will change the "fan on delay" from 45 seconds to 32 seconds. Once the "fan on delay" has been modified, it will not change back to 45 seconds unless power is reset to the control. On units with 2 stages of heat, W2 closes and initiates power to the second stage of the main gas valve when additional heat is required.

When the thermostat is satisfied, W1 and W2 open and the gas valve closes, interrupting the flow of gas to the main burners. If the call for W1 lasted less than 1 minute, the heating cycle will not terminate until 1 minute after W1 became active. If the unit is controlled through a room thermostat set for fan auto, the indoor fan motor will continue to operate for an additional 45 seconds and then stop. An LED indicator is provided on the IGC to monitor operation.

See Fig. 44 for IGC board component layout. Figure 45 is a typical IGC control wiring diagram and Table 5 for IGC Board LED Alarm Codes.

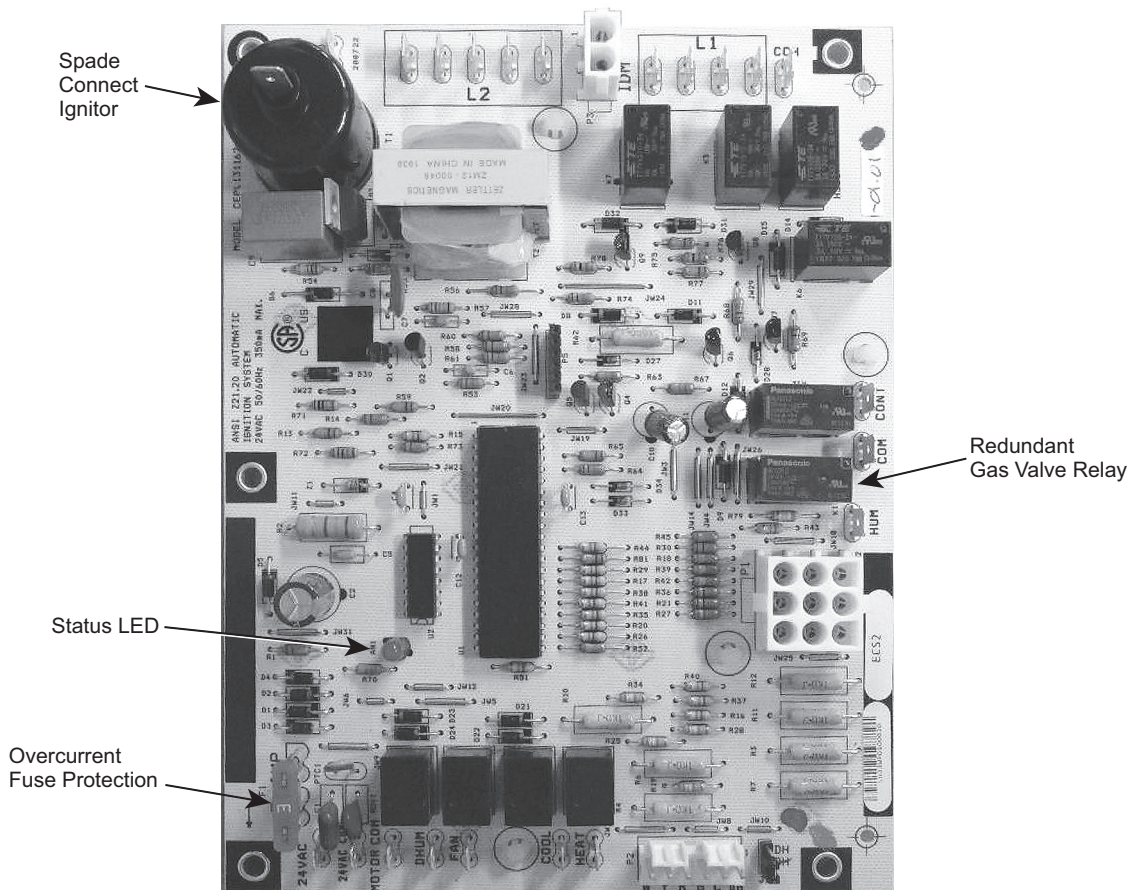

Fig. 44 — IGC Board Component Layout

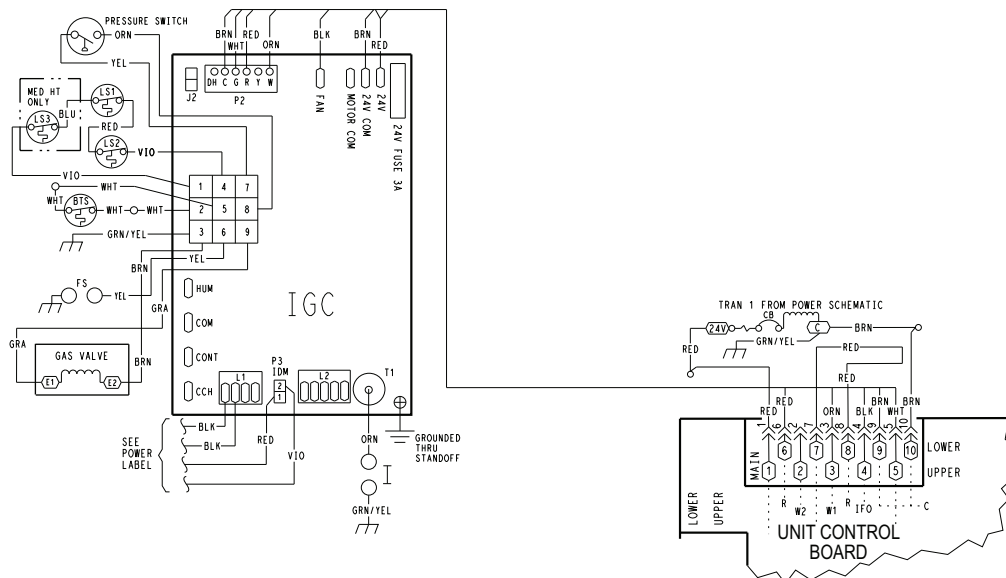

Fig. 45 — Typical IGC Control Wiring Diagram

Table 5 — IGC Board LED Alarm Codes^{a,b,c,d}

LED FLASH CODE	DESCRIPTION	ACTION TAKEN BY CONTROL	RESET METHOD	PROBABLE CAUSE
On	Normal Operation	—	—	—
Off	Hardware Failure	No gas heating.	—	Loss of power to the IGC. Check 5 amp fuse on IGC, power to unit, 24-v circuit breaker, transformer, and wiring to the IGC.
1 Flash	Indoor Fan On/Off Delay Modified	5 seconds subtracted from On delay. 5 seconds added to Off delay (3 minute maximum).	Power reset.	High temperature limit switch opens during heat exchanger warm-up period before fan-on delay expires. High temperature limit switch opens within 10 minutes of heat call (W) Off. See Limit Switch Fault.
2 Flashes	Limit Switch Fault	Gas valve and igniter Off. Indoor fan and inducer On.	Limit switch closed or heat call (W) Off.	High temperature limit switch is open. Check the operation of the indoor (evaporator) fan motor. Ensure that the supply-air temperature rise is within the range on the unit nameplate. Check wiring and limit switch operation.
3 Flashes	Flame Sense Fault	Indoor fan and inducer On.	Flame sense normal. Power reset for LED reset.	The IGC sensed a flame when the gas valve should be closed. Check wiring, flame sensor, and gas valve operation.
4 Flashes	Four Consecutive Limit Switch Fault	No gas heating.	Heat call (W) Off. Power reset for LED reset.	Four consecutive limit switch faults within a single call for heat. See Limit Switch Fault.
5 Flashes	Ignition Fault	No gas heating.	Heat call (W) Off. Power reset for LED reset.	Unit unsuccessfully attempted ignition for 15 minutes. Check igniter and flame sensor electrode spacing, gaps, etc. Check flame sense and igniter wiring. Check gas valve operation and gas supply.
6 Flashes	Induced Draft Motor/Pressure Switch Fault	If heat off: no gas heating. If heat on: gas valve Off and inducer On.	Inducer sense normal or heat call (W) Off.	Inducer sense On when heat call Off, or inducer sense Off when heat call On. Check wiring, voltage, and operation of IGC motor. Check inducer motor and flue gas pressure switch.
7 Flashes	Rollout Switch Lockout	Gas valve and igniter Off. Indoor fan and inducer On.	Power reset.	Rollout switch has opened. Check gas valve operation. Check induced-draft blower wheel is properly secured to motor shaft.
8 Flashes	Internal Control Lockout	No gas heating.	Power reset.	IGC has sensed internal hardware or software error. If fault is not cleared by resetting 24-v power, check for bad gas valve, replace the IGC.
9 Flashes	Temporary Software Lockout	No gas heating.	One hour auto reset or power reset.	Electrical interference is disrupting the IGC software.

NOTE(S):

- There is a 3-second pause between alarm code displays.
- If more than one alarm code exists, then all applicable alarm codes will be displayed in numerical sequence.
- Alarm codes on the IGC will be lost if power to the unit is interrupted.
- If the flue gas inducer pressure switch is stuck closed on a W1 call, then the unit will sit idle, and the IGC will produce no fault codes.

LEGEND

- IGC** — Integrated Gas Unit Control
LED — Light-Emitting Diode

Leak Dissipation System

48FE(G/H) units use R-454B refrigerant. These units are equipped with a factory installed R-454B leak dissipation system to ensure safe operation in the event of a refrigerant leak. This system consists of an A2L sensor (Fig. 46) and the dissipation control board (see Fig. 47) which are located in the Indoor Coil section of the unit (see the view labeled “BACK” in Fig. 2 on page 7). The A2L sensor is located between the indoor coil and the air filters.

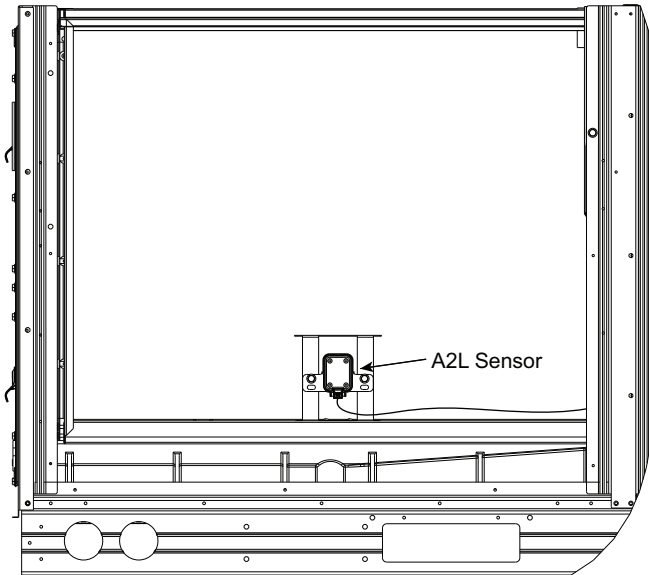

Fig. 46 – Location of A2L Sensor

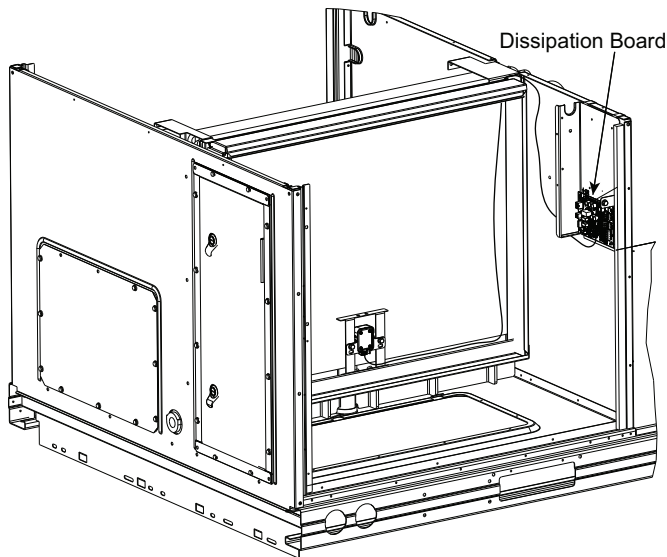

Fig. 47 – Location of Dissipation Control Board (Shown with Dust Cover Removed)

The A2L detection sensor communicates via a wiring harness to the dissipation board. The sensor harness is routed on the bottom of the filter rack towards the unit bulkhead and secured with wire ties. The sensor harness then runs up the side of the filter rack and exits over the top of the rack towards the dissipation board.

NOTE: The drain wire must be properly connected to the ground lug on the dissipation board via the quick connect and ground harness. Failure of proper sensor harness grounding can lead to false dissipation events.

SEQUENCE OF OPERATION

The control functions as an R-454B refrigerant dissipation system. If the refrigerant detection sensor sends a signal indicating a refrigerant leak, the control board will prevent heating and cooling operation and begin dissipating the sensed refrigerant with a blower request. The refrigerant dissipation board will display a flash code from the yellow status LED (see Fig. 48) indicating the sensor that detected the refrigerant. See Fig. 50 on page 31 for the full text on the Dissipation Control dust cover label

When the sensor signal indicates the refrigerant has dissipated, the dissipation board yellow status LED will display a flash code 3 and return to its normal state and allow unit operations after a 5 minute delay.

LEAK DISSIPATION SYSTEM SELF-TEST

Power on the unit and verify proper functioning of equipment. The yellow Status LED on the dissipation board should be steady (see Fig. 48). If flash codes are present, see Troubleshooting on page 31.

NOTE: Operation of the Test Mode is only possible if no faults exist on the dissipation board.

Remove the dust cover from the Dissipation control board to access the Test button (see Fig. 49). The Test button is located above the COMM LED.

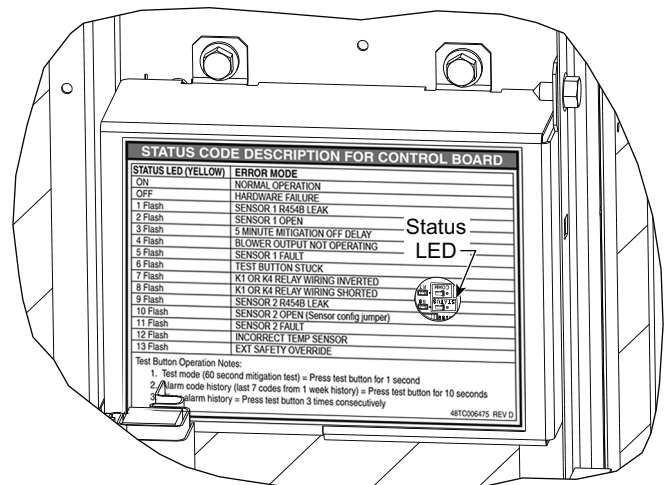
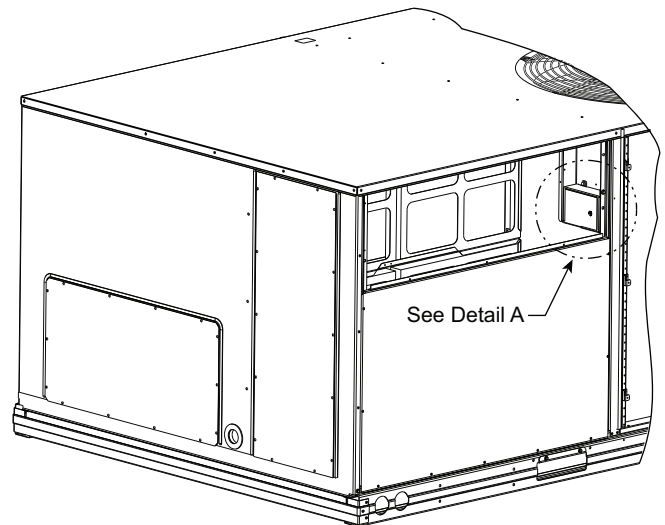

Detail A

Fig. 48 – Yellow STATUS LED

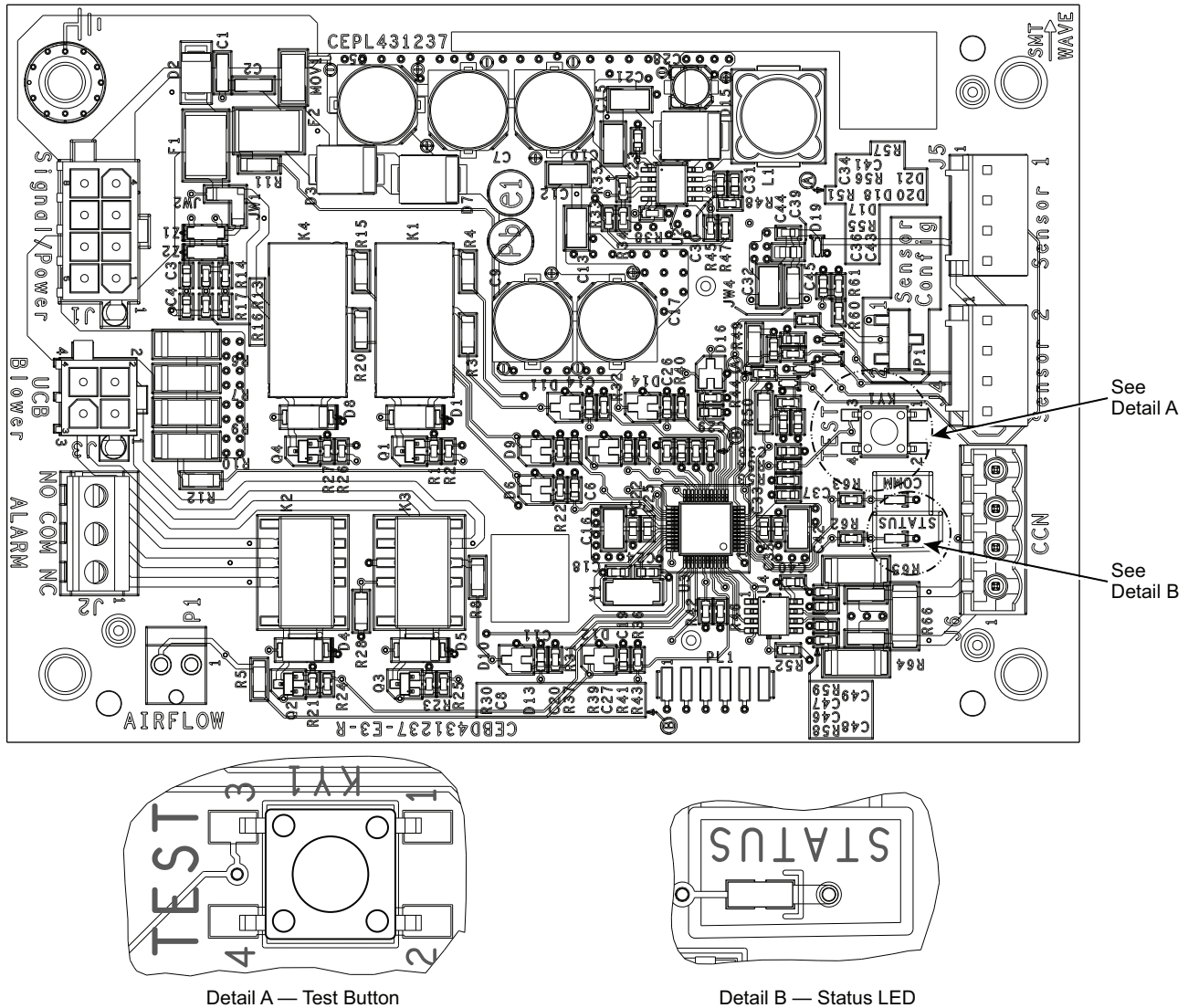

Fig. 49 — Dissipation Control Board — Shown without Dust Cover

Press the Test button on the dissipation system control board to ensure proper dissipation system operation under each test condition listed below. After pressing the Test button, system will enter Dissipation Mode for 60 seconds to help verify correct operation.

Ensure that the unit is able to meet the minimum required dissipation mode airflows. These required minimum airflow rates during Dissipation Mode are listed in Table 7. They are based on the total system refrigerant charge quantity.

IMPORTANT: Press the Test button for roughly ONE SECOND to enter Test Mode. Pressing the Test button for a longer periods enables different functions (see Table 6).

Table 6 — Dissipation Board Test Button Functions

HOLD BUTTON TIME (SEC)	FUNCTION
1-4	Dissipation Mode for 60 seconds
5-29	Display flash code history
30+	Flash code 6
3 Rapid Presses	Clear flash code history

Table 7 — Minimum Dissipation Air Flows

MINIMUM DISSIPATION AIR FLOW (cfm)	
UNIT	cfm
48FE(G/H)A04	190
48FE(G/H)A05	390
48FE(G/H)A06	340
48FE(G/H)B04	300
48FE(G/H)B05	570
48FE(G/H)B06	620

Table 8 details the required operational checks to ensure proper dissipation system function.

Table 8 — Dissipation System Required Operational Checks

NORMAL OPERATION				
TEST NO.	UNIT DEMAND	COMPRESSOR	INDOOR FAN	ELECTRIC/ GAS HEAT
1	None	Off	Off	Off
2	Cool	On	On	Off
3	Heat	On	On	On
DISSIPATION ACTIVATED				
4	None	Off	On	Off
5	Cool	Off	On	Off
6	Heat	Off	On	Off

Figure 50 shows the flash codes displayed on the Dissipation Control Board.

STATUS CODE DESCRIPTION FOR CONTROL BOARD	
STATUS LED (YELLOW)	ERROR MODE
ON	NORMAL OPERATION
OFF	HARDWARE FAILURE
1 Flash	SENSOR 1 R454B LEAK
2 Flash	SENSOR 1 OPEN
3 Flash	5 MINUTE MITIGATION OFF DELAY
4 Flash	BLOWER OUTPUT NOT OPERATING
5 Flash	SENSOR 1 FAULT
6 Flash	TEST BUTTON STUCK
7 Flash	K1 OR K4 RELAY WIRING INVERTED
8 Flash	K1 OR K4 RELAY WIRING SHORTED
9 Flash	SENSOR 2 R454B LEAK
10 Flash	SENSOR 2 OPEN (Sensor config jumper)
11 Flash	SENSOR 2 FAULT
12 Flash	INCORRECT TEMP SENSOR
13 Flash	EXT SAFETY OVERRIDE

Test Button Operation Notes:
 1. Test mode (60 second mitigation test) = Press test button for 1 second
 2. Alarm code history (last 7 codes from 1 week history) = Press test button for 10 seconds
 3. Clear alarm history = Press test button 3 times consecutively

48TC006475 REV D

Fig. 50 — Dissipation Control Cover Label

TROUBLESHOOTING

For all flash codes, first try power cycling the system to remove the code.

No Power

Verify the wiring to/from pins 1 and 8 on the power harness plug. Check the 24V system wiring from the transformer.

See Table 9 for details on the operating status and troubleshooting of the Dissipation system for the various flash codes.

Table 9 — Status LED Troubleshooting Table

STATUS LED	REASON	CONTROL VERBIAGE	MODE
Flashing 1	Sensor 1 ≥ 20% LFL	SENSOR 1 R454B LEAK	Dissipation in Process
Flashing 2	Sensor 1 Open	SENSOR 1 OPEN	Dissipation in Process
Flashing 3	5 Minute Blower Operating, Sensor < 20% LFL and sensors are not opened (done after fault 1, 2, 9 and 10)	MITIGATION OFF DELAY ACTIVE	Dissipation in Process
Flashing 4	0 VAC sensed on G output.	BLOWER OUTPUT NOT OPERATING	Dissipation in Process
Flashing 5	Fault with the A2L digital sensor	SENSOR 1 FAULT	Dissipation in Process
Flashing 6	If KY1 is stuck pressed for more than 30 seconds.	TEST BUTTON STUCK	To prevent a shorted KY1 to keep the mitigation running continuously.
Flashing 7	Y out switched with Y in or W out switched with W in	Y (K4) OR W (K1) WIRING INVERTED	Normal mode
Flashing 8	Y or W shorted (relay detects both sides are high)	Y (K4) OR W (K1) OUTPUT SHORTED TO Y (K4) OR W (K1) INPUT	Normal mode
Flashing 9 ^a	Sensor 2 ≥ 20% LFL	SENSOR 2 R454B LEAK	Dissipation in Process
Flashing 10 ^a	Sensor 2 Open	SENSOR 2 OPEN	Dissipation in Process
Flashing 11 ^a	Fault with the second A2L digital sensor	SENSOR 2 FAULT	Dissipation in Process
Flashing 12	High temperature sensor attached on commercial	INCORRECT TEMP SENSOR	Normal mode
Flashing 13	G input signal is lost. Indicates another unit safety will override dissipation.	EXT SAFETY OVERRIDE	Normal mode

NOTE(S):

- a. There is only one sensor mounted in these units. This table represents the standard label being put on all commercial equipment. The hardware changes only allow one sensor to be connected to the board; the software remains the same for a one or two sensor board. Although unlikely these flash codes may appear if the board malfunctions.

LEGEND

LFL — Lower Flammable Limit

Humidi-MiZer® Dehumidification System (Optional)

Units with the factory-installed Humidi-MiZer system option are capable of providing multiple modes of improved dehumidification as a variation of the normal cooling cycle. The Humidi-MiZer system option includes additional valves in the liquid line and discharge line of the refrigerant circuit and a reheat coil downstream of the evaporator. Humidi-MiZer system operation requires the installation and configuration of a relative humidity switch input or a space relative humidity sensor. These provide the dehumidification demand to the control.

With Humidi-MiZer system units, there are two additional HVAC modes available for the user: Dehumidification and Dehum/Mech Cooling. Selection of the Dehum/Mech Cooling mode is determined by the dehumidification demand and the cooling demand. Table 10 shows the corresponding circuit mode and output status for the different demand combinations.

NORMAL COOLING

This mode is the standard rated cooling system performance, and occurs when there is cooling demand without dehumidification demand.

For 48FE(G/H) 04-06 units, refrigerant flows through the outdoor condenser and is diverted away from the reheat coil with the open Cooling Liquid Valve (CLV) into the expansion device. Figure 51 shows the complete refrigerant flow. The Reheat Discharge Valve (RDV) is closed.

DEHUM/MECH COOLING (SUBCOOLING) MODE

This mode increases the latent heat removal and decreases sensible cooling compared to normal cooling. This occurs when there is a cooling and dehumidification demands.

For 48FE(G/H) 04-06 units, refrigerant flows through the outdoor condenser and is diverted through the reheat coil with the closed CLV into the expansion device. Figure 52 shows the complete refrigerant flow. The RDV is closed.

DEHUMIDIFICATION (HOT GAS REHEAT) MODE

This mode provides maximum latent cooling with little to no sensible capacity. This occurs when there is a dehumidification demand and no cooling demand.

For 48FE 04-06(G/H) units, this is the same as the Subcooling mode but the RDV is open, which provides some compressor discharge gas to the reheat condenser to further increase the reheat of the evaporator air stream. (See Fig. 53.)

REHEAT CONTROL

When there is only a cooling demand, the unit will operate in normal cooling mode. When there is only dehumidification demand, the unit will operate in Dehumidification mode (Hot Gas Reheat). When there is both cooling demand and dehumidification demand, the unit will operate in Dehum/Mech Cooling mode (Subcooling). During Dehumidification and Dehum/Mech cooling mode, the unit will run all cooling stages.

Table 10 – Humidi-MiZer System Control Modes

DEMAND AND MODE			OUTPUTS		
Dehumidification Demand	Cooling Demand	Mode	Compressor	RDV	CLV
No Power	No Power	No power	Off	De-energized (no flow)	De-energized (flow)
No	No	Off	Off	De-energized (no flow)	De-energized (flow)
No	Yes	COOL	On	De-energized (no flow)	De-energized (flow)
Yes	No	DEHUM	On	Energized (flow)	Energized (no flow)
Yes	Yes	DEHUM/MECH COOL	On	De-energized (no flow)	Energized (no flow)

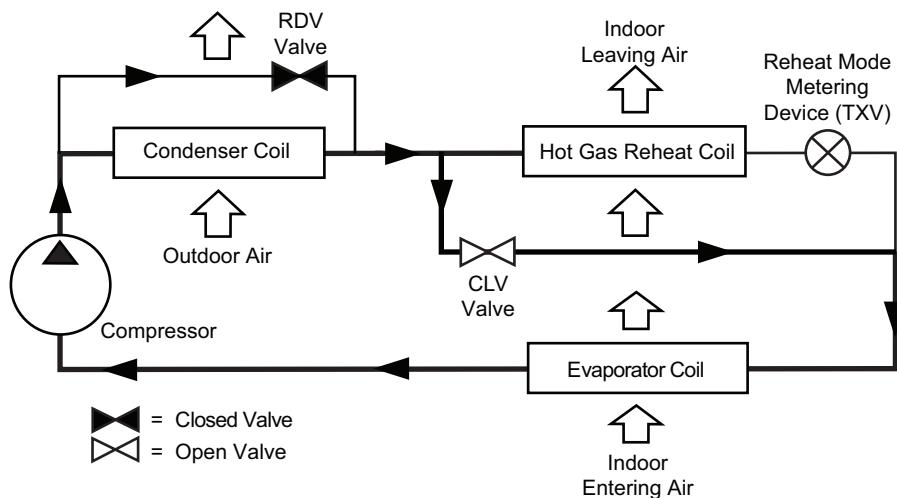

Fig. 51 – Normal Cooling Mode – Humidi-MiZer System with Single Stage Cooling

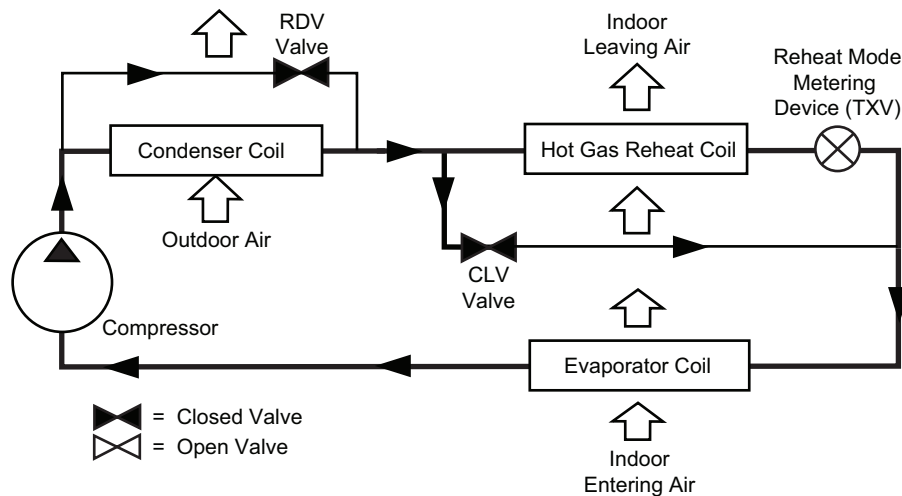

Fig. 52 – Subcooling Mode – Humidi-MiZer System with Single Stage Cooling

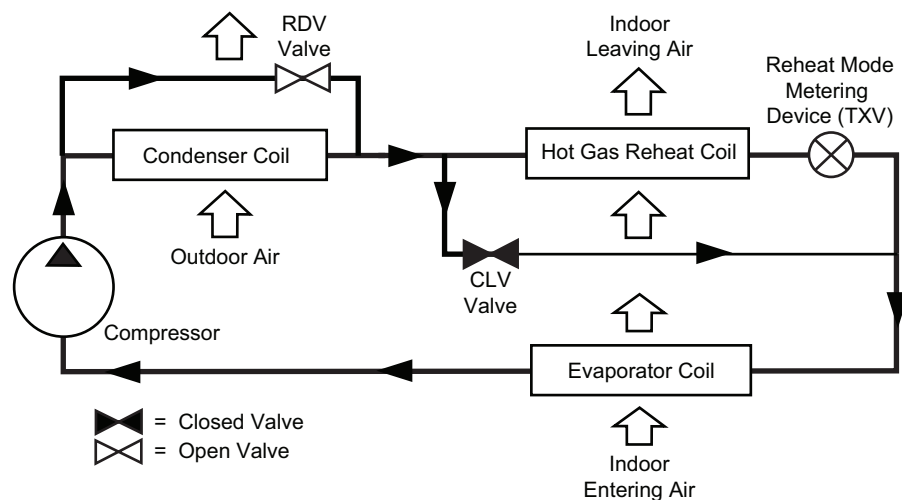

Fig. 53 – Hot Gas Reheat Mode – Humidi-MiZer System with Single Stage Cooling

Temporary Furnace Operation During Construction

The furnace may be operated during the finishing stage of construction. To ensure proper operation follow the steps below.

1. Prior to the finishing stage of construction, ensure that return air and vent openings are covered to minimize penetration of dust and construction debris into the unit.
2. Interior drywall installation shall be completed and covered with paint or primer prior to unit operation.
3. Premises shall be substantially free of debris and dust.
4. Ensure all return and vent coverings have been removed.
5. Verify the return ducts and supply ducts are connected, are free from obstructions, are clean, and are properly sealed.
6. Ensure proper vent installation per installation instructions.
7. Ensure gas piping has been connection per installation instructions.
8. Verify that the gas piping is free of leaks.
9. Furnace to be set to operate under appropriate control to ensure proper operation.
10. Minimum MERV 11 air filters to be installed during the finishing stages of construction.
11. Set furnace input rate and temperature rise per rating plate marking.

12. Ensure means for providing combustion air in accordance with the manufacturer's shipped installation instructions.
13. Return air temperature to be maintained between 55°F (13°C) and 80°F (27°C).
14. Furnace shall be set up to operate in accordance with installation instructions and shall be verified for operating conditions including ignition, input rate, temperature rise, and venting.
15. Install new filters as per installation instructions prior to final occupancy.

EconomizerONE (Factory Option)

ECONOMIZER SETTINGS

Interface Overview

EconomizerONE

This option consists of the following:

- Low Leak Economizer Assembly
- HH79NZ039 OA (Outdoor Air) Dry Bulb Sensor
- HH79NZ039 Mixed Air Sensor
- POL224 Controller
- 48TC005897 Harness

POL224 Economizer Module Wiring

The economizer controller used on electromechanical units is a Siemens POL224, which is to be located in the RTU base unit's

control box. See Fig. 54 for button description of the POL224 controller. Refer to the unit dimensional drawing for the location of the control box access panel.

The POL224 controller provides the following:

1. One-line LCD (Liquid Crystal Display) — After a period of inactivity, the controller displays the default HMI (Human Machine Interface) screen (free cooling status, 1FREECOOL YES or 1FREECOOL NO). See Fig. 54-58.
2. Operation button (Up button) — Move to the previous value, step, or category.
3. Operation button (Down Button) — Move to the next value, step, or category.
4. Operation Button (Enter Button):
 - a. Press Enter to edit the current value or option.
 - b. Press Enter to confirm a newly selected value or option.
 - c. Press Enter + Up to jump up one entire category.
 - d. Press Enter + Down to jump down one entire category.

User Interface and Keypad

The controller user interface consists of an LCD display and a 3-button keypad for input. The LCD is a 16 character by 1-line dot matrix display. The keypad is used to navigate and change the desired menu items on the display. See Fig. 54.

The Climatix™ mobile application allows for installation, commissioning, and servicing. Scanning a QR code on the controller allows users to download the mobile application on Android™ or Apple iOS®, but a Wi-Fi/WLAN stick is needed. See Fig. 54 and 55. Plug Wi-Fi/WLAN stick into controller USB port for temporary connection for mobile application set-up. The Wi-Fi/WLAN stick can be used for multiple units.

Menu Structure

Menus are displayed in the economizer controller via categories. There are eight first-level menus, each of which is represented by a number at the beginning of the line on the LCD. Pressing Enter + Up or Down can toggle between different first-level menus. Submenus follow the numbered first-level menus closely. Pressing Up or Down can toggle between different submenus.

At the end of the line, the LCD displays the value of the current submenu (if any). If the value is editable, pressing Enter will put the terminal in Edit mode. The value is then highlighted for change. After making a change by pressing Up or Down, press Enter to confirm the change and exit the Edit mode. See Fig. 57.

Powering the Economizer Controller

The POL224 controller power connections are made through the economizer harness (P/N 48TC005897). Connections from the harness are made to the C (24 vac common) and R (24 vac power) terminals of the economizer controller. See Fig. 56.

LED Indication

NOTE: If different faulty events occur at the same time, then sensor/DAC LED lights up following the priority below: Red → Yellow → Off. For example, if there is a humidity sensor error and air temperature failure at the same time, then the sensor LED turns red rather than yellow. See Fig. 58 and Table 11.

IMPORTANT: After the Economizer controller enters the running state, it may take one minute for peripheral devices to complete initialization. Before that, LED indication might be unstable.

1. Third-party trademarks and logos are the property of their respective owners.

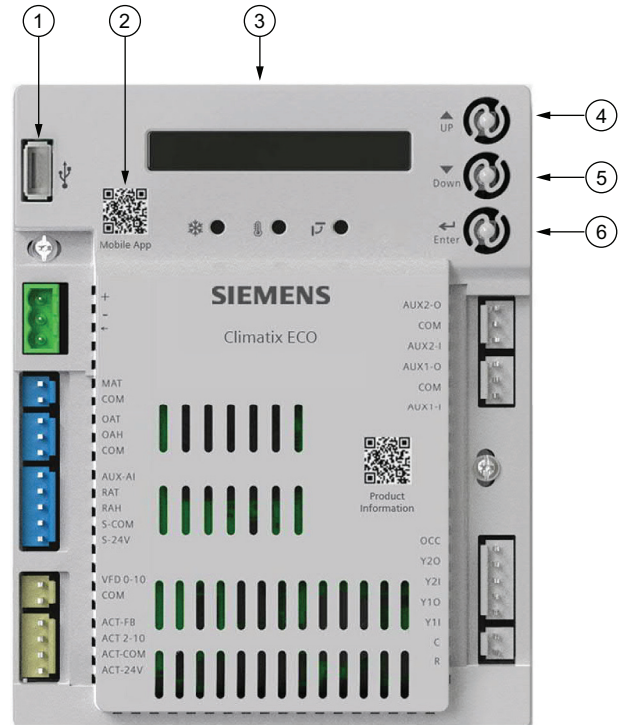

NOTE: QR codes in this image are for reference only.

NO.	DESCRIPTION
1	USB port for Wi-Fi/WLAN stick.
2	QR code to download Climatix™ mobile application.
3	One-line LCD. After a period of inactivity, the controller displays the default: HMI screen (free cooling status, 1FREECOOL YES or 1FREECOOL NO)
4	Operation button (Up button) - Move to the previous value, step or category.
5	Operation button (Down button) - Move to the next value, step or category.
6	Operation button (Enter button): <ul style="list-style-type: none"> • Press to edit the current value or option. • Press to confirm a newly selected value or option. • Press Enter + Up to jump up one entire category. • Press Enter + Down to jump down one entire category.

Fig. 54 — POL224 Controller



NOTE: QR code in this image is for reference only.

Fig. 55 — Wi-Fi/WLAN Stick

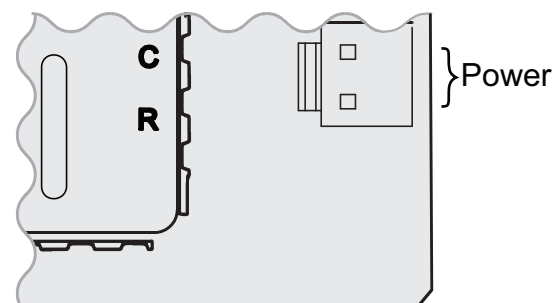
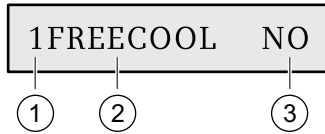

Fig. 56 — Powering the EconomizerONE Controller



No.	Description
1	Number representing the first-level menu of Status Display . Different numbers represent different menus: 1: Status Display 2: Basic Settings 3: Advanced Settings 4: Alarms 5: Enter Configuration State and Reset 6: I/O Config 7: Testing 8: Enter Running State
2	Submenu ^a
3	Value of the current submenu ^a

a. See "Setup and Configuration" on page 44 for detailed submenus together with possible values or ranges.

Fig. 57 – Menu Structure Descriptions

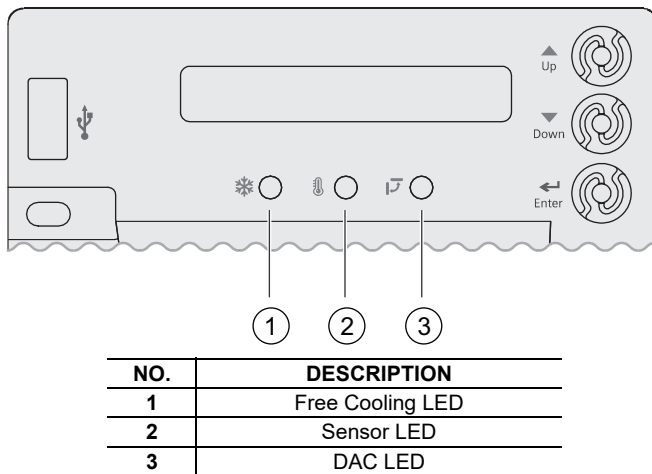

Fig. 58 – LED Indication

Table 11 – LED Indication

STATUS	FREE COOLING LED	SENSOR LED	DAC LED
Commissioning mode	Yellow Blinking	Yellow Blinking	Yellow Blinking
Power start up	Yellow On	Yellow On	Yellow On
Free cooling is running	Green On	—	—
Free cooling is available but not running	Green Blinking	—	—
Not economizing when it should	Red Blinking	—	—
Economizing when it should not	Red On	—	—
Sensor working okay	—	Green On	—
Humidity sensor error	—	Yellow On	—
CO₂ sensor error	—	LED Off	—
Air temperature fault/failure	—	Red On	—
Excess outdoor air	—	Red Blinking	—
Damper working okay	—	—	Green On
Damper not modulating	—	—	Red On
Damper slippage	—	—	Red Blinking
Damper unplugged	—	—	Fast Red Blinking
Terminal ACT-FB is configured but no available feedback signal	—	—	LED Off

Functions

Free Cooling Economizing

Free cooling uses unconditioned outside air to cool the space directly. The economizer controller enables or disables free cooling after it judges which control mode is active. It also uses hysteresis to ensure a smooth switchover.

Depending on the sensors that are used, there are four different control modes. In different control modes, the assessed conditions are different. See Table 12.

Default Hysteresis Setting

Hysteresis setting (DB) defaults to 2°F (-17°C). See Fig. 59.

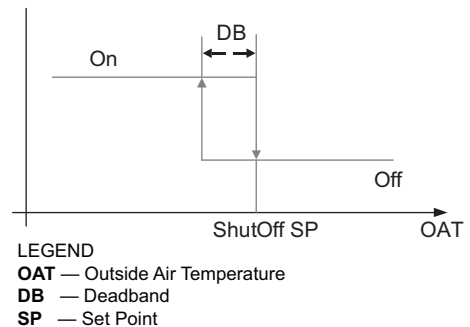

Fig. 59 – Hysteresis Settings

Table 12 – Free Cooling Functions

CONTROL MODE	SENSORS USED	ENABLE FREE COOLING?
Control Mode 1 • Fixed Dry bulb	OA (outside air) Temperature Sensor and MA (Mixed Air) Temperature Sensor	The outside air dry bulb temperature is compared with the set temperature shutoff setpoint. If the outside air dry bulb temperature is below the temperature shutoff setpoint, then the outside air is used to meet all or part of the cooling demand.
Control Mode 2 • Differential Dry bulb (Dual Dry bulbs)	OA Temperature Sensor, RA (Return Air) Temperature Sensor, and MA Temperature Sensor	The outside-air dry bulb temperature is compared with the return air dry bulb temperature. If both OAT and RAT are higher than the temperature high limitation, then free cooling is prohibited. If OAT or RAT is lower than the temperature high limitation and the outside air dry bulb temperature is lower than the return air dry-bulb temperature, then the outside air is used to meet all or part of the cooling demand.
Control Mode 3 • Combination Fixed Enthalpy and Fixed Dry bulb Control	OA Temperature and Humidity Sensor and MA Temperature Sensor	The outside air dry bulb temperature and enthalpy are compared with the set temperature and enthalpy shutoff setpoints. If the outside air enthalpy is lower than the set enthalpy shutoff setpoint, and the outside air dry bulb temperature is lower than the temperature shutoff setpoint, then the outside air can be used for economizing.
Control Mode 4 • Combination of Differential Enthalpy and Fixed Dry bulb	OA Temperature and Humidity Sensor, RA Temperature and Humidity Sensor, and MA Temperature Sensor	The outside air dry bulb temperature and enthalpy are compared with the temperature shutoff setpoint and return air enthalpy. If both OA enthalpy and RA enthalpy are higher than the enthalpy high limitation, then free cooling is prohibited. If OA enthalpy or RA enthalpy is lower than the enthalpy high limitation, outside air enthalpy is lower than the return-air enthalpy, and the outside air dry bulb temperature is lower than the set temperature shutoff setpoint, then outside air can be used for economizing.

Damper Modulation During Free Cooling

Once outside air is suitable for free cooling, the controller modulates the damper based on MAT (mixed air temperature, default) or OAT (outside air temperature). Refer to Table 12.

If MAT is used when free cooling is enabled, MAT setpoint (**3MAT SET**, configurable in “Parameter Settings — Advanced” on page 47) is used for MAT modulating. When MAT falls below the anti-freeze setpoint (**3FRZ PROT**), the damper either fully closes or opens to the minimum position (configurable in “Parameter Settings — Advanced” on page 47).

1. If MAT is lower than MAT setpoint, then the damper is modulated to maintain MAT setpoint, towards fully closed or open to the minimum position based on occupancy status if MAT continues dropping.
2. If MAT is in the range [MAT setpoint, (MAT setpoint + neutral zone band [1°F by default])], then the damper position does not change.
3. If MAT is higher than (MAT setpoint + neutral zone band), then the damper opens towards fully open.
4. If MAT is 10°F higher than MAT setpoint, then the damper fully opens to 100%.

If OAT is used when there is a cooling demand, the damper can be opened to different positions depending on different outside air temperatures:

1. If outside air is higher than 50°F but lower than the temperature shutoff setpoint, then the damper is fully open.
2. If outside air is higher than OAT lockout setpoint but lower than 50°F, then linear modulation is applied when only

Cooling Stage 1 input (Y1) is ON. Result of the following formula indicates the damper’s open position:

$$([OAT - OAT Lockout Setpoint] / [50 - OAT Lockout Setpoint]) * (80\% - MIN POS) + MIN POS$$

NOTE: When both free cooling and mechanical cooling are on, damper remains fully open regardless of the modulating logic.

Location-Based Shutoff Setpoints

The economizer controller can get location-based temperature and enthalpy shutoff setpoints automatically if it is connected to the Climatix™ mobile application. Once a Wi-Fi/WLAN stick is plugged in, the economizer controller can establish network connection with the mobile application. The temperature and enthalpy shutoff setpoints obtained via the phone or tablet’s GPS functionality can then be synchronized to the economizer controller.

Cooling Stage Operation

The economizer controller accepts inputs for 1 and 2-stage cooling inputs and reroutes to the RTU through the relay connection Y1 and Y2.

The operation of the cooling stages is determined by the availability of Free Cooling provided by the economizer operation mode. See Cooling Stage I/O Logic Tables 13-14. Based on the use of Free Cooling, the operating modes are as follows:

- Y1 is Stage 1 Cooling Demand.
- Y2 is Stage 2 Cooling Demand.
- Free Cooling is always the first cooling stage.
- Cooling Stage 1 call from the Commercial Thermostat (Y1) energizes the Y1 input to the economizer controller.
- Cooling Stage 2 call from the Commercial Thermostat (Y2) energizes the Y2 input to the economizer controller.

Table 13 — 1 and 2-Stage Cooling Stage I/O Logic

ECONOMIZER CONDITION MET	Y1	Y2	COOLING STAGE 1	COOLING STAGE 2
NO	On	On	On	On
NO	On	Off	On	Off
NO	Off	Off	Off	Off
YES	On	On	On	On/Off ^a
YES	On	Off	Off	Off
YES	Off	Off	Off	Off

NOTE(S):

- a. If $OAT \leq MAT$ setpoint (3MAT SET), then Relay 2 is always **OFF** to disable Cooling Stage 2. Otherwise, if both stages of cooling (Y1 and Y2) are **ON** for more than a set time (15 minutes by default), Y2 remains ON, and the OAT is higher than MAT setpoint, then Relay 2 energizes to allow Y2 pass-through to enable Cooling Stage 2.

Table 14 — 2-Stage Cooling Stage I/O Logic

ECONOMIZER CONDITION MET	Y1	Y2	COOLING STAGE 1	COOLING STAGE 2
NO	On	On	On	On
NO	On	On	On	On
NO	On	Off	On	Off
NO	Off	Off	Off	Off
YES	On	On	On	On
YES	On	On	On	On/Off
YES	On	Off	Off	Off
YES	Off	Off	Off	Off

IMPORTANT: The economizer controller can tolerate thermostat wiring mismatch, e.g. Thermostat Y1 → Economizer Y2-In, Thermostat Y2 → Economizer Y1-In. The handling logic is Stage = Y1I + Y2I. For example, Y1O = 1 if Stage >= 1, Y2O = 1 if Stage >= 2.

Multi-Speed Fan Support

The economizer controller supports connection to 2-speed fans. When the unit is equipped with a multi-speed fan, the damper responds to multiple fan speeds via multiple minimum positions (**MIN POS**) to keep minimum airflow. See Tables 15-17.

Table 15 — Damper MIN POS for 2-Speed Fan^a

Y1	Y2	W1 OR O/B	SPD L	SPD H	POS L	POS H
X	—	—	X	—	X	—
X	X	—	—	X	—	X
—	—	X	—	X	—	X

NOTE(S):

- a. A multi-speed fan is not controlled by the economizer controller but by an external logic board.

LEGEND

- POS L** — Damper MIN POS for Low-Speed Fan
POS H — Damper MIN POS for High-Speed Fan
SPD L — Low-Speed (Fan)
SPD H — High-Speed (Fan)

Table 16 — Different Fan Speeds with Different Configured Outputs^a

FAN TYPE	1-SPEED COOLING ^b	2-STAGE COOLING ^b
1-SPEED FAN^c	• Spd H (regardless of cooling demand, OCC=Yes)	• Spd H (regardless of cooling demand, OCC=Yes)
2-SPEED FAN^c	• Spd L (0 or 1 cooling demand) • Spd H (2 cooling demands)	• Spd L (0 or 1 cooling demand) • Spd H (2 cooling demands)

NOTE(S):

- a. If a single-speed fan connects to the Controller, it opens directly on the call of cooling/heating. The damper position is Pos H.
b. Configured by Y1O or Y2O.
c. Configured by 6FAN.

LEGEND

- Spd L** — Low Speed (Fan)
Spd H — High Speed (Fan)

Table 17 — Different Damper Minimum Positions with Different Configured Outputs

FAN TYPE	1-SPEED COOLING ^a	2-STAGE COOLING ^a
1-SPEED FAN^b	• Pos H (regardless of cooling demand, OCC=Yes)	• Pos H (regardless of cooling demand, OCC=Yes)
2-SPEED FAN^b	• Pos H (regardless of cooling demand, OCC=Yes)	• Pos L (0 or 1 cooling demand) • Pos H (2 cooling demands)

NOTE(S):

- a. Configured by Y1O or Y2O.
b. Configured by 6FAN.

LEGEND

- Pos L** — Damper MIN POS for Low-Speed Fan
Pos H — Damper MIN POS for High-Speed Fan

If DCV (demand controlled ventilation) is enabled, each fan speed corresponds to two damper position ventilation setpoints (VENT MIN, VENT MAX), e.g., Pos L corresponds to 2VENTMIN L... 2VENTMAX L. See Table 18 for Different Damper Position Setting with Different Configured Outputs with DCV enabled.

If CO₂ sensor is connected but DCV is disabled, then each fan speed corresponds to one minimum damper position ventilation setpoint. See Table 19 for Different Damper Position Setting with Different Configured Outputs with DCV disabled.

Table 18 – Different Damper Position Settings with Different Configured Outputs (DCV is Enabled)

FAN TYPE	1-STAGE COOLING ^a	2-STAGE COOLING ^a
1-SPEED FAN ^b	• 2VENTMIN H to 2VENTMAX H (regardless of cooling demand, OCC=Yes)	• 2VENTMIN H to 2VENTMAX H (regardless of cooling demand, OCC=Yes)
2-SPEED FAN ^b	• 2VENTMIN H to 2VENTMAX H (regardless of cooling demand, OCC=Yes)	• 2VENTMIN L to 2VENTMAX L (0 or 1 cooling demand) • 2VENTMIN H to 2VENTMAX H (2 cooling demands)

NOTE(S):

- a. Configured by Y10 or Y20.
- b. Configured by 6FAN.

Table 19 – Different Damper Position Settings with Different Configured Outputs (DCV is Disabled, CO₂ sensor is connected)

FAN TYPE	1-STAGE COOLING ^a	2-STAGE COOLING ^a
1-SPEED FAN ^b	• 2VENTMIN H (regardless of cooling demand, OCC=Yes)	• 2VENTMIN H (regardless of cooling demand, OCC=Yes)
2-SPEED FAN ^b	• 2VENTMIN H (regardless of cooling demand, OCC=Yes)	• 2VENTMIN L (0 or 1 cooling demand) • 2VENTMIN H (2 cooling demands)

NOTE(S):

- a. Configured by Y10 or Y20.
- b. Configured by 6FAN.

Cooling Delay via Increasing Fan Speed

If there is cooling demand while outside air is suitable for economizing, then the economizer controller tries to increase fan speed to maximize the use of outside air first. If the cooling demand is not reached within a set time, then mechanical cooling will be enabled.

Typical field application:

1. Prerequisites:
 - Outside air is suitable for economizing and free cooling is ON.
 - Fan connected to the controller supports multiple speeds. Cooling delay function does not work if only a one-speed fan is connected to the controller.
2. If it is a 2-speed fan and there are two cooling demand inputs/outputs and Y1-Input is called, then the controller sets fan speed to Speed Low. Damper is fully open (100%).
If Y2-Input is also called, then the controller increases fan speed to Speed High and starts fan delay (2FAN DLY) time. After the delay time runs out, the controller starts Y1-Output.

Demand Controlled Ventilation (DCV)

If a field-installed CO₂ sensor is connected to the EconomizerONE controller, then a demand controlled ventilation strategy will operate automatically. As the CO₂ level in the space increases above the setpoint (on the EconomizerONE controller), the minimum position of the dampers will be increased proportionally until the Maximum Ventilation setting is reached. As the space CO₂ level decreases because of the increase in fresh air, the outdoor damper will follow the higher demand condition from the DCV mode or from the free cooling mode.

The controller modulates the outside air damper based on the CO₂ level through the ppm value selected between the range of 500 and 2000 ppm. The measured CO₂ concentration value is compared with the set DCV setpoint. If the measured CO₂ concentration value is below the DCV setpoint, then keep the damper to the minimum position. Otherwise, enable DCV. Once DCV is enabled, the DCV PID starts to run to control the indoor CO₂ concentration value towards the DCV setpoint. The damper opens to the maximum position.

NOTE: DCV is disabled if the controller receives no occupancy signal.

DCV operation is available in Occupied and Unoccupied periods with the EconomizerONE system. However, a control modification will be required on the unit system to implement the Unoccupied period function. Refer to controller accessory installation instruction manual for further controls and command operation information.

High Humidity Limitation

The economizer controller applies high limit of humidity to enthalpy-based economizing. When the OA dew point is below the dew point setpoint, enthalpy-based economizing is available. Otherwise, enthalpy-based economizing is unavailable.

Anti-Freeze Protection

The economizer controller initiates the anti-freeze protection if MAT or OAT temperature falls below the anti-freeze setpoint.

MAT-Based Anti-Freeze Protection

1. If MAT temperature falls below the anti-freeze setpoint (3FRZ PROT), then:
 - The controller closes both damper and compressor if unit type is conventional unit and cooling/heating conventional operation mode is enabled.
 - The controller closes the damper if unit type is heat pump and heat pump operation mode is enabled.
2. If the MAT sensor fails, MAT is substituted by OAT to continue the anti-freeze assessment. If OAT fails too, the controller closes the damper immediately.

OAT-Based Anti-Freeze Protection

If OAT temperature falls below the OAT lockout setpoint (3OAT LOCK):

1. The controller stops the compressor from running if unit type is conventional unit and cooling/heating conventional operation mode is enabled.
2. The controller compressor is bypassed if unit type is heat pump and heat pump operation mode is enabled.

Exhaust Fan Operation

Up to two exhaust fans can be connected to the economizer controller.

- If Exhaust Fan 1 is connected and configured, then Exhaust Fan 1 parameter group (L, M, and H) is available, depending on fan configuration.
- If Exhaust Fan 2 is connected and configured, then Exhaust Fan 2 parameter group (L, M, and H) is available, depending on fan configuration.
- The controller energizes Exhaust Fan Relay 1 and Exhaust Fan Relay 2 if the damper position reaches Exhaust Fan 1 parameter setting and Exhaust Fan Relay 2 parameter setting respectively. The selection of L, M, or H matches the current fan speed.

NOTE: If terminal ACT-FB is configured, then the damper position is the damper feedback position. If feedback signal is unavailable, it is the simulated position.

Occupancy Input

The economizer controller can receive an occupancy signal from the connected thermostat or work under Occupied mode all the time. This is configurable in the Thermostat setup from the Climatix™ mobile application or under the I/O Configuration menu on the inbuilt display. See “Parameter Settings — I/O Configurations” on page 47 for more information.

IMPORTANT: On the call of cooling, when the controller is configured to receive signal from the thermostat but the thermostat is working under the Unoccupied mode, the damper is fully closed if outside air is not suitable for economizing. If outside air is suitable for economizing, the damper is fully open.

Pre-occupancy Purge

The pre-occupancy purge demand comes from the configuration of the Auxiliary features in the Climatix™ mobile application or 6AUX2-I under the I/O Configuration menu on the inbuilt display.

During pre-occupancy purge on the call of heating or when there is no cooling/heating demand, the damper position is MIN POS.

During pre-occupancy purge on the call of cooling, the damper position is MIN POS if outside air is not suitable for economizing. If outside air is suitable for economizing, then the damper is fully open.

Airflow Commissioning

Airflow measurement station (differential pressure signal) can connect to the controller temporarily to run airflow commissioning to calculate, calibrate, and store 4 fan speed characteristic curves automatically at damper positions 40%, 60%, 80%, and 100%. The controller places the damper to a proper position to meet minimum or any other airflow requests in cfm.

Users can enable this function only from the Climatix™ mobile application if the related function is available in the current mobile application version.

Fault Detection and Diagnostics

The economizer controller can detect and diagnose free cooling faults, sensor operation faults, and damper modulating faults. It can also report anti-freeze and shutdown notifications and actuator errors. Following is a list of all detectable or reportable information:

- Sensor disconnected or has no signal.
- Sensor short or high signal (under range or over range).
- Not economizing.
- Unexpected economizing.
- Excess outdoor air.
- Damper not modulating.
- Input power monitor and brownout. After detecting brownout, the economizer controller enters the brownout protection mode and disables all of the relay outputs.
- Anti-freeze notifications.
- Shutdown notifications.
- Actuator errors.
- Too low or too high leaving air temperature.
- Cooling/heating error.
- Damper actuator cycle count. Parameter **1ACT CNT** indicates number of times actuator has cycled. It is resettable via HMI item **8ACT CNT RESET**.

IMPORTANT: The first 6 faults are detectable via LEDs or alarm reports on the LCD. See LED Indication on page 35 and Alarms on page 48 for fault indications. These faults can also be displayed in the Operating section of the Climatix™ mobile application.

Firmware Update

NOTE: Back up configurations before firmware update. All the previous configuration data are erased after firmware update. NOTE: Contact Application Engineering for more information on support for firmware.

IMPORTANT: If the controller enters the configuration state for the convenience of I/O configurations, then users can manually switch to the running state after finishing configurations. To do so, press Enter + Up at the same time, and then press Enter to confirm the switch after 8RUN STATE appears on the LCD.

⚠ WARNING

Failure to follow this caution may result in damage to equipment. Be sure to allow enough time for compressor startup and shutdown between checkout tests so that the compressors do not short-cycle.

Mounting Devices Connected to the Economizer Controller

Devices like damper actuators, sensors (temperature sensor, humidity sensor, combination temperature and humidity sensor, CO₂ sensor), thermostats, and exhaust fans can be connected to the economizer controller. For information on how to mount the devices, see the device's installation instructions. See Fig. 60 and Table 20 for economizer controller wiring details.

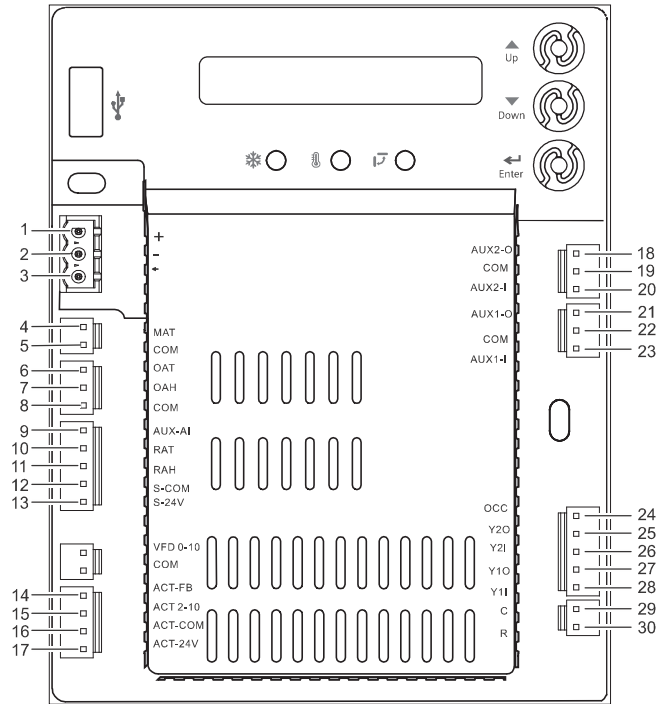

Fig. 60 — EconomizerONE Control Wiring

Table 20 – EconomizerONE Control Wiring Settings

NO.	LABEL	TYPE	DESCRIPTION
1	+	RS485 Modbus A	Line A
2	-	RS485 Modbus B	Line B
3	⏏	GND_ISO	Earth Ground
4	MAT	Type II NTC 10K or 0-10 vdc	Mixed or Discharge Air Temperature Sensor
5	COM	COM	Mixed or Discharge Air Temperature Sensor Common
6	OAT	Type II NTC 10K or 0-10 vdc	Outside Air Temperature Sensor
7	OAH	0-10 vdc or 4-20mA	Outside Air Relative Humidity Sensor
8	COM	COM	Outside Air Temperature Sensor or Outside Air Relative Humidity Sensor Common
9	AUX-AI	0-10 vdc, 2-10 vdc or 0-5 vdc	Air Quality Sensor or Pressure Sensor
10	RAT	Type II NTC 10K or 0-10 vdc	Return Air Temperature Sensor
11	RAH	0-10 vdc or 4-20mA	Return Air Relative Humidity Sensor
12	S-COM	COM	24 vac Common
13	S-24V	24 vac	24 vac Power Out to Sensors
14	ACT-FB	2-10 vdc	Damper Actuator Feedback
15	ACT2-10	2-10 vdc	Damper Actuator Output
16	ACT-COM	COM	Damper Actuator Output Common
17	ACT-24V	24 vac	24 vac Power Out to Damper Actuator
18	AUX2-O	24 vac OUT	Configurable: • Exhaust Fan (1 or 2) • System Alarm output (Title 24)
19	COM	COM	24 vac Common
20	AUX2-I	24 vac IN	Configurable: • Shut Down • Heat Conventional (W1) • Heat Pump Changeover (reversing valve OB) • Pre-occupancy
21	AUX1-O	24 vac OUT	Configurable: • Exhaust Fan (1 or 2) • System Alarm output (Title 24)
22	COM	COM	24 vac Common
23	AUX1-I	24 vac IN	Configurable: • Shut Down • Heat Conventional (W1) • Heat Pump Changeover (reversing valve OB) • Pre-occupancy
24	OCC	24 vac IN	Occupancy Input
25	Y2O	24 vac OUT	Cooling Stage 2 Output to Stage 2 Mechanical Cooling
26	Y2I	24 vac IN	Cooling Stage 2 Input from Commercial Thermostat
27	Y1O	24 vac OUT	Cooling Stage 1 Output to Stage 1 Mechanical Cooling
28	Y1I	24 vac IN	Cooling Stage 1 Input from Commercial Thermostat
29	C	COM	24 vac Common
30	R	24 vac	24 vac Power

Connecting Peripheral Devices to the Economizer Controller

See Fig. 61-65 for wiring details.

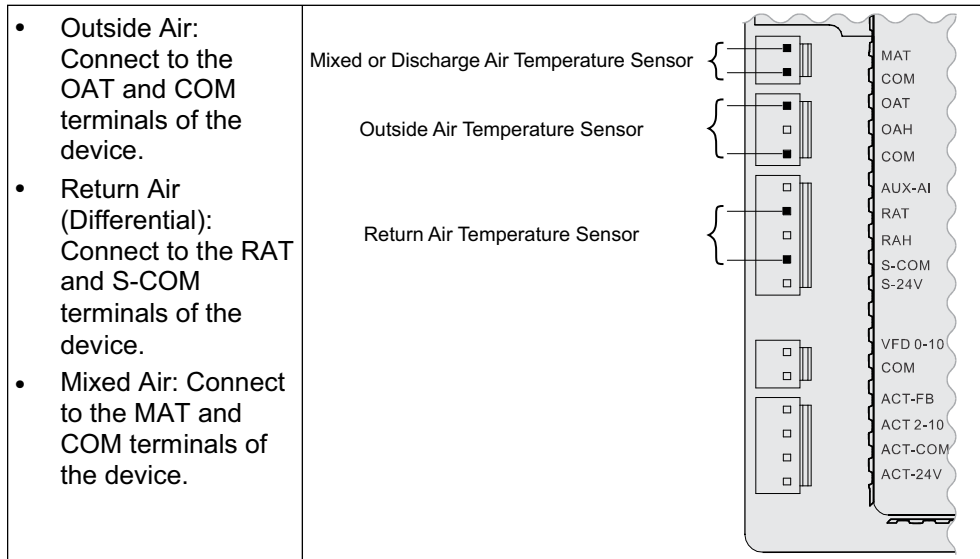

Fig. 61 — Temperature Sensor Connection

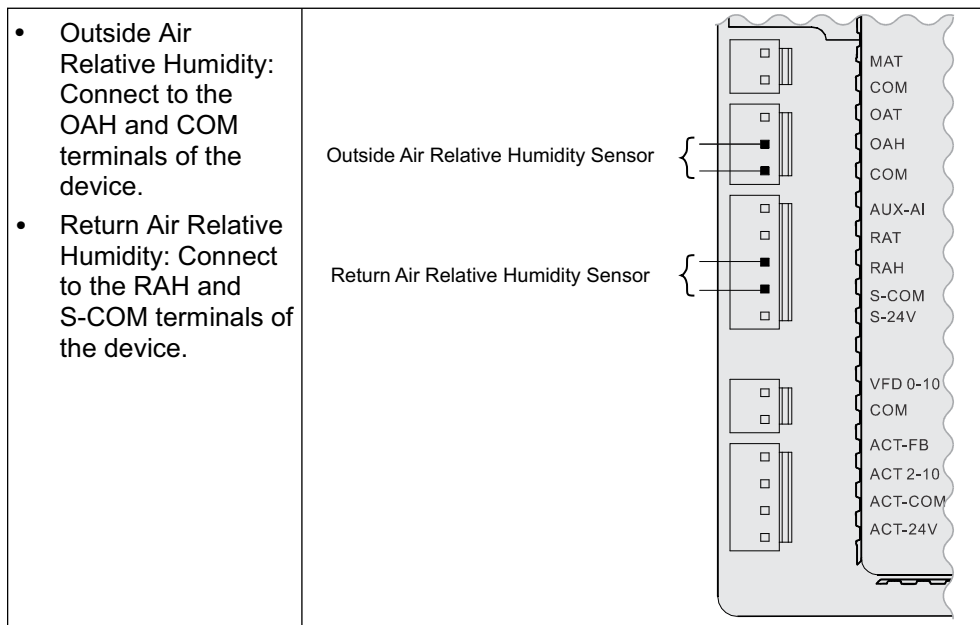

Fig. 62 — Relative Humidity Sensor Connection

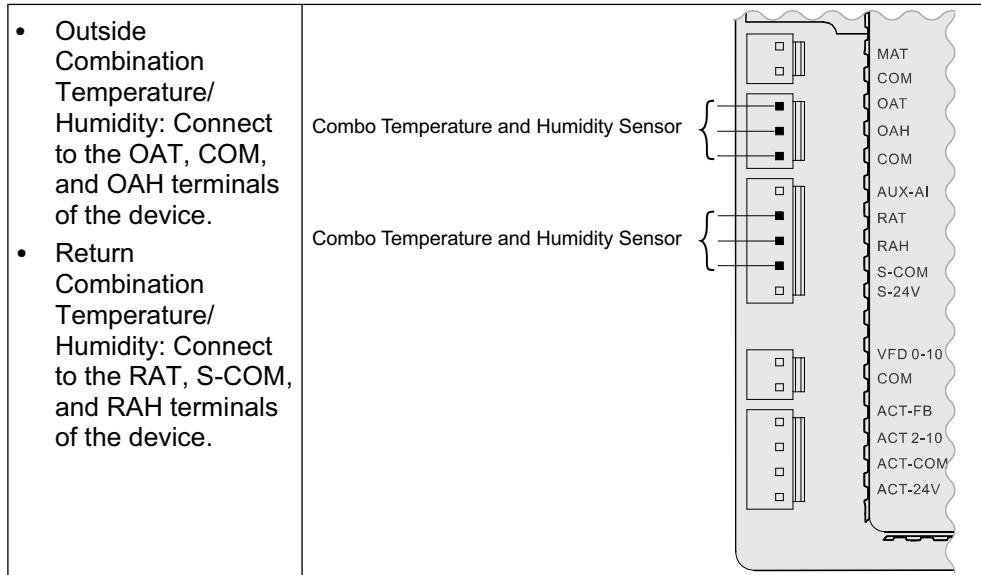

Fig. 63 — Combination Temperature/Humidity Sensor Connection

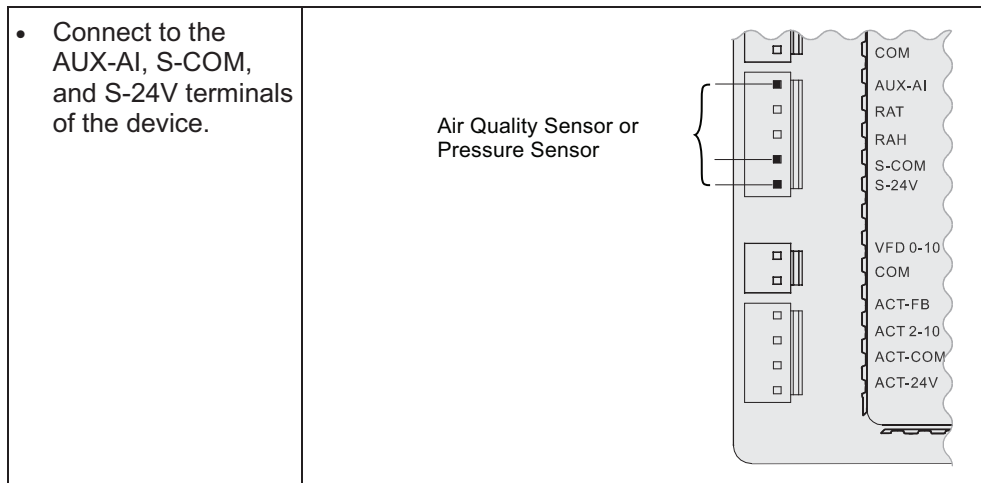

Fig. 64 — CO₂/Pressure Sensor Connection

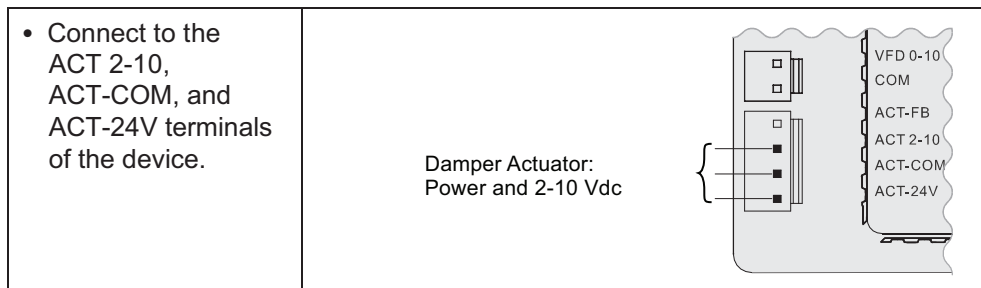

Fig. 65 — Damper Actuator Connection

SETUP AND CONFIGURATION

IMPORTANT: Before setup and configuration, it is recommended to obtain some location-based values, such as shutoff points, or utilize the location services in the Climatix™ mobile application.

Set up and configure the economizer controller before putting it into usage. This can be accomplished by using the Climatix™ mobile application or the inbuilt display. After sensor, compressor, thermostat, or actuator is connected to the economizer controller, values/statuses are displayed in the Operating section of the mobile application and on the LCD. Users can manually change basic and advanced settings, configure I/Os, and test the damper operation and any configured outputs by modifying the corresponding parameter values in the local device or mobile application. See Tables 21-28 for complete list of all parameters available on the LCD display. Refer to it during the setup and configuration process.

NOTE: For all units, the Climatix application login is: **Administrator**. For units coming from the factory with CO₂ configuration or single enthalpy (control mode 3), the controller password is OneBT2.1. For all other units, use the controller password OneBT.

NOTE: Parameters and display menus may display differently/dynamically if different applications are configured. See Tables 21-28.

IMPORTANT: Not all operations are available on the local POL224. For example, users can only obtain shutoff setpoints and perform cfm commissioning via the Climatix™ mobile application. Setup and configuration on the local device are only recommended if operations from the mobile application are unavailable. Check the mobile application for all operations that can be performed from the mobile application end.

IMPORTANT: By connecting the RS485 port to a PC, all parameters are also readable or writable from PC tools such as Modbus Poll.exe via Modbus®^a and Yabe.exe via BACnet®^a MSTP (Bps 38400 [default], Bps 9600, Bps 19200, Bps 115200). Note that an external End of Line (EOL) element is required to achieve Baud Rate 115200 at a maximum cable length of 4000 ft (1.2 km).

NOTE(S):

a. Third-party trademarks and logos are the property of their respective owners.

Table 21 – Status Display

PARAMETER	DESCRIPTION	VALUE
1FREECOOL	Indicates whether the system can use outdoor air for free cooling.	YES NO
1ECON ENAB	Indicates whether outdoor air is being used for the first stage of cooling.	
1OCCUPIED	Indicates whether the space is occupied. If users choose ALWAYS for 6OCC when configuring I/Os, then the parameter value is YES ; if users keep the default selection T-STAT for 6OCC and the controller receives 24-v signal from OCC input, then the value is YES . Otherwise, the value is NO .	YES NO
1Y1-IN	Y1-In call from thermostat for Cooling Stage 1.	
1Y1-OUT	Y1-Out signal to compressor for Cooling Stage 1.	ON OFF
1Y2-IN	Y2-In call from thermostat for Cooling Stage 2.	
1Y2-OUT	Y2-Out signal to compressor for Cooling Stage 2. Dynamic item: Appears only if Y2-Out terminal is configured.	
1AUX1-I	Aux1-In signal Dynamic item: Appears only if Aux1-In terminal is configured.	
1AUX1-O	Aux1-Out signal Dynamic item: Appears only if Aux1-Out terminal is configured.	
1AUX2-I	Aux2-In signal Dynamic item: Appears only if Aux2-In terminal is configured.	
1AUX2-O	Aux2-Out signal Dynamic item: Appears only if Aux2-Out terminal is configured.	
1COMP STAGE	Indicates compressor current stage.	
1HEAT ENAB	Indicates whether heating is enabled.	YES NO
1MIX AIR LOW	Indicates whether the anti-freeze protection function is enabled for a mixed air temperature sensor. If the detected air temperature is lower than the anti-freeze protection setpoint (3FRZ PROT), then the parameter value is YES . Otherwise, it is NO .	
1MAT PRES	Indicates the present value of the mixed air temperature (MAT) sensor. Dynamic item: Appears only if MAT or AUTO is selected for 3DIF T LOC under Parameter Settings — Advanced on page 47.	The corresponding detected value is displayed on the LCD.
1LAT PRES	Indicates the present value of the leaving air temperature (LAT) sensor. Dynamic item: Appears only if LAT or AUTO is selected for 3DIF T LOC .	
1OAT PRES	Indicates the present value of the outdoor air temperature (OAT) sensor. Dynamic item: Appears only if an OAT sensor is configured.	
1OAH PRES	Indicates the present value of the outdoor air relative humidity (OAH) sensor. Dynamic item: Appears only if an OAH sensor is configured.	
1RAT PRES	Indicates the present value of the return air temperature (RAT) sensor. Dynamic item: Appears only if a RAT sensor is configured.	
1RAH PRES	Indicates the present value of the return air relative humidity (RAH) sensor. Dynamic item: Appears only if a RAH sensor is configured.	
1CO2 PRES	Indicates the present value of the CO ₂ sensor. Dynamic item: Appears only if a CO ₂ sensor is configured.	
1DCV STATUS	Indicates the demand controlled ventilation (DCV) status. Dynamic item: Appears only if a CO ₂ sensor is configured. Displays ON if the measured CO ₂ concentration value is above the DCV setpoint and OFF if below the DCV setpoint.	
1FAN SPD LV	Indicates the current fan speed status (low, medium, or high). If a one-speed fan is connected and configured, then this item is invisible. Dynamic item: Appears only if "6FAN" is configured as "2SPEED" under Parameter Settings — I/O Configurations on page 47.	L H
1ACT OUT	Indicates current position of damper actuator in V.	The corresponding detected value is displayed on the LCD.
1ACT FB	Indicates feedback signal of damper actuator in V.	
1ACT POS	Indicates current position of damper actuator in % Open.	
1ACT CNT	Indicates number of times actuator has cycled (1 cycle = 180 degrees of movement in any direction). Resettable via HMI item 8ACT CNT RESET under Enter Running State on page 49.	
1EQUIP	Indicates the equipment type. If HP(O) or HP(B) is chosen for 6AUX1-I , then the parameter value is HP(O) or HP(B) respectively. If neither is chosen, then the value is CON RTU .	HP(O) HP(B) CON RTU
1OAT LOCK	Indicates status of the OAT cooling lockout function.	NO LCKOUT OVRD
1INS	Indicates the installation date of the economizer controller. If the installation date is incorrect, press Enter to change and confirm month, date, and year.	—

Table 22 – Parameter Settings – Basic

PARAMETER	DESCRIPTION	RANGE	DEFAULT
2 TEMP OFF	Temperature shutoff setpoint can be obtained automatically if a smartphone or tablet with the mobile application installed on it is connected to the network provided by a Wi-Fi/WLAN stick plugged into the economizer controller. This can also be a manually defined setpoint.	48...80°F; increment by 1	63°F
2ENTH OFF	Enthalpy shutoff setpoint can be obtained automatically if a smartphone or tablet with the mobile application installed on it is connected to the network provided by a Wi-Fi/WLAN stick plugged into the economizer controller. This can also be a manually defined setpoint. Dynamic item: Appears only if an OAH sensor is configured.	22...30 Btu/lbm; increment by 1	28 Btu/lbm
2DVC	Demand controlled ventilation setpoint can be obtained automatically if a smartphone or tablet with the mobile application installed on it is connected to the network provided by a Wi-Fi/WLAN stick plugged into the economizer controller. This can also be a manually defined setpoint. Dynamic item: Appears only if a CO ₂ sensor is configured.	300...2000PPM; increment by 100	1100PPM
2FAN L ACT	Damper minimum position when fan runs at a low speed. Dynamic item: Appears only if "6FAN" is configured as "2SPEED" under Parameter Settings — I/O Configurations on page 47.	2...10V; increment by 0.1	3.6V
2FAN H ACT	Damper minimum position when fan runs at a high speed. Dynamic item: Appears only if "6FAN" is configured as "1SPEED" or "2SPEED".	2...10V; increment by 0.1	2.8V
2VENTMAX L	DCV maximum position when fan runs at a low speed. Dynamic item: Appears only if a CO ₂ sensor is configured and "6FAN" is configured as "2SPEED".	2...10V; increment by 0.1	3.6V
2VENTMAX H	DCV maximum position when fan runs at a high speed. Dynamic item: Appears only if a CO ₂ sensor is configured and "6FAN" is configured as "1SPEED" or "2SPEED".	2...10V; increment by 0.1	3.6V
2VENTMIN L	DCV minimum position when fan runs at a low speed. Dynamic item: Appears only if a CO ₂ sensor is configured and "6FAN" is configured as "2SPEED".	2...10V; increment by 0.1	3.1V
2VENTMIN H	DCV minimum position when fan runs at a high speed. Dynamic item: Appears only if a CO ₂ sensor is configured and "6FAN" is configured as "1SPEED" or "2SPEED".	2...10V; increment by 0.1	2.3V
CFM COMM	Air Flow Chart: CFM commissioning can only be initiated from the mobile application. When CFM commissioning is in progress, the local device reads "CFM COMM".	—	—
2DEGREES	Temperature unit (°F or °C).	—	°F
2FAN	Fan cfm.	100...50,000cfm; increment by 100	5000cfm
2EX1 L	Exhaust Fan 1 low-speed parameter setting. Dynamic item: Appears only if: • Exhaust Fan 1 is configured. • "6FAN" is configured as "2SPEED".	0...100%; increment by 1	65%
2EX1 H	Exhaust Fan 1 high-speed parameter setting. Dynamic item: Appears only if: • Exhaust Fan 1 is configured. • "6FAN" is configured as "1SPEED" or "2SPEED".	0...100%; increment by 1	50%
2EX2 L	Exhaust Fan 2 low-speed parameter setting. Dynamic item: Appears only if: • Exhaust Fan 2 is configured. • "6FAN" is configured as "2SPEED".	0...100%	80%
2EX2 H	Exhaust Fan 2 high-speed parameter setting. Dynamic item: Appears only if: • Exhaust Fan 2 is configured. • "6FAN" is configured as "1SPEED" or "2SPEED".	0...100%; increment by 1	75%
2THL	Temperature high limitation. Dynamic item: Appears only if an RAT sensor is configured.	0...100%; increment by 1	83%
2EHL	Enthalpy high limitation. Dynamic item: Appears only if an RAH sensor is configured.	30...50 Btu/lbm; increment by 1	33 Btu/lbm
2FAN DLY	Cooling delay via increasing fan speed.	0...30 min; increment by 1	5 min.

Table 23 – Parameter Settings – Advanced

PARAMETER	DESCRIPTION	VALUE/RANGE	DEFAULT
3FREEZE POS	Anti-freeze protection damper position (closed or minimum).	CLO MIN	CLO
3SD ACT POS	Damper position during shutdown (open or closed).	CLO OPN	CLO
3DIF T LOC	MAT sensor location: <ul style="list-style-type: none"> Choose MAT if the sensor is installed before the DX (Direct Expansion) coil. Choose LAT if the sensor is installed after the DX coil. Choose AUTO to let the economizer controller automatically detect the location. 	MAT LAT AUTO	LAT
3LAT LOW	Low limit of leaving air temperature. Dynamic item: Appears only if LAT or AUTO is selected for 3DIF T LOC .	35...65°F; increment by 1	45°F
3LAT HIGH	High limit of leaving air temperature. Dynamic item: Appears only if LAT or AUTO is selected for 3DIF T LOC .	70...180°F; increment by 1	80°F
3OAT CAL	OAT sensor calibration.	-2.5...2.5°F; increment by 0.5	0°F
3RAT CAL	RAT sensor calibration. Dynamic item: Appears only if an RAT sensor is configured.	-2.5...2.5°F; increment by 0.5	—
3OAH CAL	OAH sensor calibration. Dynamic item: Appears only if an OAH sensor is configured.	-10...10%; increment by 0.5	0%
3RAH CAL	RAH sensor calibration. Dynamic item: Appears only if an RAH sensor is configured.		
3MAT CAL	MAT or LAT sensor calibration.	-2.5...2.5°F; increment by 0.5	0°F
3MAT SET	Setpoint of MAT or LAT sensor.	38...70°F; increment by 1	53°F
3FRZ PROT	Anti-freeze protection setpoint of MAT sensor.	35...55°F; increment by 1	45°F
3ACT TOLR	Actuator tolerance setpoint between output (in percent) and feedback (in percent).	0...15%; increment by 1	8%
3OAT LOCK	OAT lockout set point for anti-freeze protection.	-45...80°F; increment by 1	32°F
3OAT LCKOVRD	When OAT LOCKOUT is enabled, choose to override the cooling lockout function or not.	YES NO	NO
3OAT LOCKDLY	Indicates the overridden time if “ YES ” is selected for “ 3OAT LCKOVRD ”.	0...300 min; increment by 1	45 min.

Table 24 – Parameter Settings – I/O Configurations

PARAMETER	DESCRIPTION	VALUE	DEFAULT
6OCC	Configures whether occupancy status receives signal from the connected thermostat or is displayed as ALWAYS in the economizer controller.	T-STAT ALWAYS	T-STAT
6AUX1-I	Auxiliary DI-1. Configurable as: <ul style="list-style-type: none"> None Heat Conventional (W1) from thermostat Heat pump (reversing valve O) Heat pump (reversing valve B) Pre-occupancy signal from thermostat Shutdown signal from unit 	NONE HP(O) HP(B) PREOCC SHUTDWN	W1
6AUX2-I	Auxiliary DI-2. Configurable as: <ul style="list-style-type: none"> None Heat stage 1 (W1) from thermostat Heat pump (reversing valve O) Heat pump (reversing valve B) Pre-occupancy signal from thermostat Shutdown signal from unit NOTE: Whichever is chosen for 6AUX1-I does not appear in the list of 6AUX2-I.	NONE W1 HP(O) HP(B) PREOCC SHUTDWN	NONE
6OAT SIG	Configures signal type of OAT sensor.	0-10V NTC10K	NTC10K
6RAT SIG	Configures signal type of RAT sensor.	0-10V NTC10K NONE	NONE
6OAH SIG	Configures signal type of OAH sensor.	0-10V 4-20mA NONE	NONE
6RAH SIG	Configures signal type of RAH sensor.		
6MAT SIG	Configures signal type of MAT or LAT sensor.	0-10V NTC10K	NTC10K
6AUX-AI1	Auxiliary AI-1. Configurable as: <ul style="list-style-type: none"> CO₂ sensor Static pressure (temporarily for cfm commissioning) sensor None 	PRESSURE CO ₂ NONE	NONE
6X-AI1 SIG	Configures CO ₂ sensor type. Dynamic item: Appears only if “ CO₂ ” is selected for “ 6AUX-AI1 ”.	0-10V 2-10V 0-5V	0-10V
6CO ₂ Rng L	Configures the low limit of CO ₂ measuring range. Dynamic item: Appears only if “ CO₂ ” is selected for “ 6AUX-AI1 ”.	0...500; increment by 10	0
6CO ₂ Rng H	Configures the high limit of CO ₂ measuring range. Dynamic item: Appears only if “ CO₂ ” is selected for “ 6AUX-AI1 ”.	1000...3000; increment by 50	2000
6AUX-AI2	Choose ACT FB if feedback signal is available from the connected damper actuator. Otherwise, choose NONE .	ACT FB NONE	ACT FB

Table 24 – Parameter Settings – I/O Configurations (cont)

PARAMETER	DESCRIPTION	VALUE	DEFAULT
6Y2O	Choose “ COOL 2 ” if Cooling Stage 2 is available (another compressor is connected to the Economizer). Otherwise, choose “ NONE ”.	COOL 2 NONE	COOL 2
6AUX1-O	Auxiliary DO-1. Configurable as: • None. • Exhaust fan (1 or 2). • Alarm output to thermostat (Title 24).	NONE ALARM EXHAUST	EXHAUST
6AUX2-O	Auxiliary DO-2. Configurable as: • None. • Exhaust fan (1 or 2). • Alarm output to thermostat (Title 24). NOTE: Except for Exhaust Fan, whichever is chosen for 6AUX1-O does not appear in the list of 6AUX2-O.	NONE ALARM EXHAUST	ALARM
6RS485	Switch between MSTP and Modbus.	MSTP MODBUSSLV	MSTP

Table 25 – Alarm Parameters^{a,b}

PARAMETER	DESCRIPTION
NO ALARM	No alarm is activated.
4MAT SEN ALARM	MAT sensor has failed, gone out of range, or become disconnected.
4CO2 SEN ALARM	CO ₂ sensor has failed, gone out of range, or become disconnected.
4OAT SEN ALARM	OAT sensor has failed, gone out of range, or become disconnected.
4OAH SEN ALARM	OAH sensor has failed, gone out of range, or become disconnected.
4RAT SEN ALARM	RAT sensor has failed, gone out of range, or become disconnected.
4RAH SEN ALARM	RAH sensor has failed, gone out of range, or become disconnected.
4FREEZE ALARM	Anti-freeze notification when MAT sensor is below anti-freeze protection setpoint.
4RTU SHUTDOWN	Notification of Shutdown Active when SHUTDWN is chosen for 6AUX1-I or 6AUX2-I.
4ACTUATOR ALARM	Actuator gets disconnected or has failed.
4ACT UNDER V	Voltage received by the actuator is below expected range.
4ACT OVER V	Voltage received by the actuator is above expected range.
4ACT STALLED	Damper actuator stopped before achieving commanded position.
4ACT SLIPPING	Damper actuator slips after reaching commanded position.
4NOT ECON	Not economizing when it should.
4ECON SHOULDNT	Economizing when it should not.
4EXCESS OA	Excess outdoor air. Outside air intake is significantly higher than it should be.
4LLA ALARM	Leaving air temperature is lower than the low limit (3LAT LOW).
4HLA ALARM	Leaving air temperature is higher than the high limit (3LAT HIGH).

NOTE(S):

- a. All alarms are dynamic items. An alarm appears only if a related symptom mentioned above is detected.
- b. An alarm activation triggers a general alarm and then the configured system alarm output (AUX1-O or AUX2-O) is activated. If there is no alarm, then NO ALARM is displayed on the HMI.

Table 26 – Test Commands

PARAMETER	DESCRIPTION
7DAMPER MIN POS	Press Enter to test whether the economizer controller can drive damper to minimum position.
7DAMPER CLOSE	Press Enter to test whether the economizer controller can drive damper to 100% Closed.
7DAMPER OPEN	Press Enter to test whether the economizer controller can drive damper to 100% Open.
7DAMPER ALL	Press Enter to perform all the above tests.
7DAMPER	Press Enter to test whether the economizer controller can drive damper to the selected voltage.
7Y1O	Press Enter to test whether the economizer controller can turn on or off the first stage of cooling (close or open relay Y1O).
7Y2O	Press Enter to test whether the economizer controller can turn on or off the second stage of cooling (close or open relay Y2O).
7AUX1-O	Press Enter to test AUX1-O connection (close or open relay AUX1-O).
7AUX2-O	Press Enter to test AUX2-O connection (close or open relay AUX2-O).

Table 27 – Enter Running State

PARAMETER	DESCRIPTION
8RUN STATE	Change to Running State. Press Enter to confirm the change.
8ENTER RUN?	Confirm the change to Running State.
8FACTORY DEF	Perform factory reset. Press Enter to confirm the reset. (This action resets the controller password to default: OneBT.)
8DEF CONFIRM?	Confirm the factory resetting.
8ACT CNT RESET	Damper count reset.
8VER x.x.x	Firmware version information such as 0.1.10.

Table 28 – Enter Configuration State and Restart

PARAMETER	DESCRIPTION
5CONFIG STATE	Change to Configuration State. Press Enter to confirm the change.
5ENTER CONFIG?	Confirm the change to Configuration State.
5RESTART	Restart the economizer controller. Press Enter to confirm the restart.
5CONF RESTART	Confirm the restart.

INSTALLING OPTIONAL HH57LW001 SINGLE OUTSIDE AIR ENTHALPY SENSOR

When using the HH57LW001 enthalpy sensor (see Fig. 66) for outside air changeover, the existing HH79NZ039 dry bulb sensor (see Fig. 67) must be removed. The enthalpy sensor will be mounted in the same location as the dry bulb sensor (see Fig. 68). When the enthalpy sensor's OA (Outside Air) temperature, enthalpy, and dew point are below their respective setpoints, the outside air can be used for free cooling. When any of these are above the setpoint, free cooling will not be available. Enthalpy setpoints are configurable and create an enthalpy boundary according to the user's input. For additional details, see Fig. 69-70 and Table 29.

Harness 48TC005213 is required to be connected between the EconomizerONE harness in the return air chamber. Harness

48TC005213 has a 5-pin plug that connects directly to the HH57LW001 enthalpy sensor. The CRENTSEN001A00 accessory kit includes enthalpy sensor (HH57LW001) and associated 5-pin plug (48TC005213) and may be ordered as a finished good.

Enthalpy Control Sensor Configuration

The optional enthalpy control sensor (P/N: HH57LW001) communicates with the POL224 economizer controller using the 5-wire harness, 48TC005213. The HH57LW001 sensor can be used as a single outside air enthalpy, a differential return enthalpy, or a differential return temperature sensor. Refer to the base unit control wiring diagrams found earlier in this book to wire the HH57LW001 enthalpy sensor for each option. Use Fig. 66 and Table 31 on page 52 to locate the wiring terminals for each enthalpy control sensor.

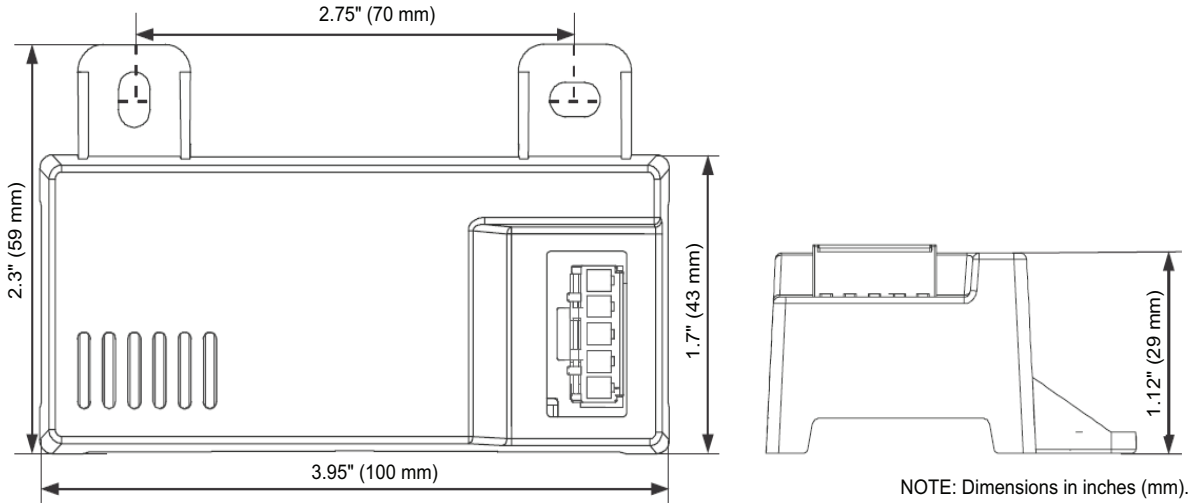

Fig. 66 – HH57LW001 Dimensional, Connection and Switching Information

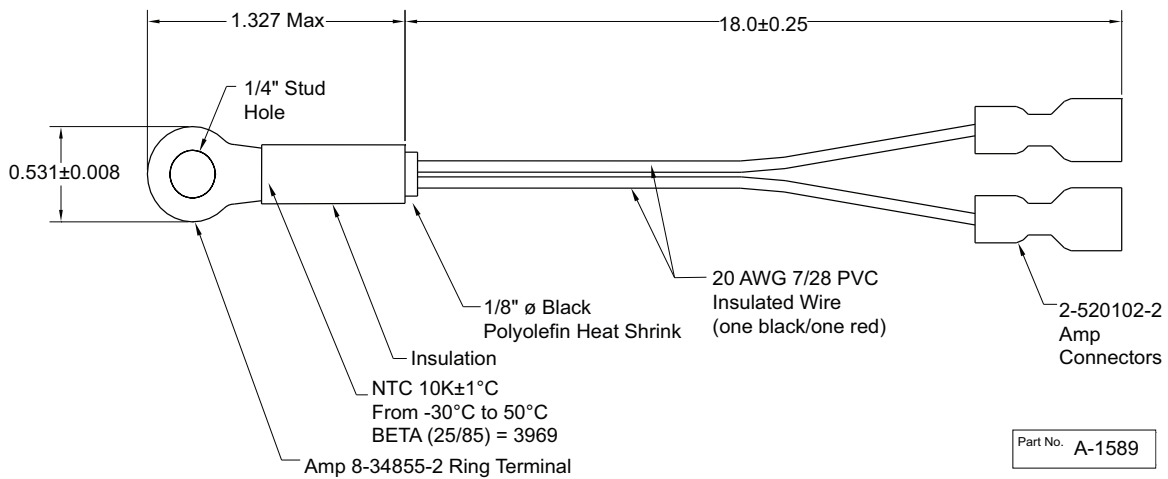

Fig. 67 – HH79NZ039 Dry Bulb and Mixed Air Sensor Wiring

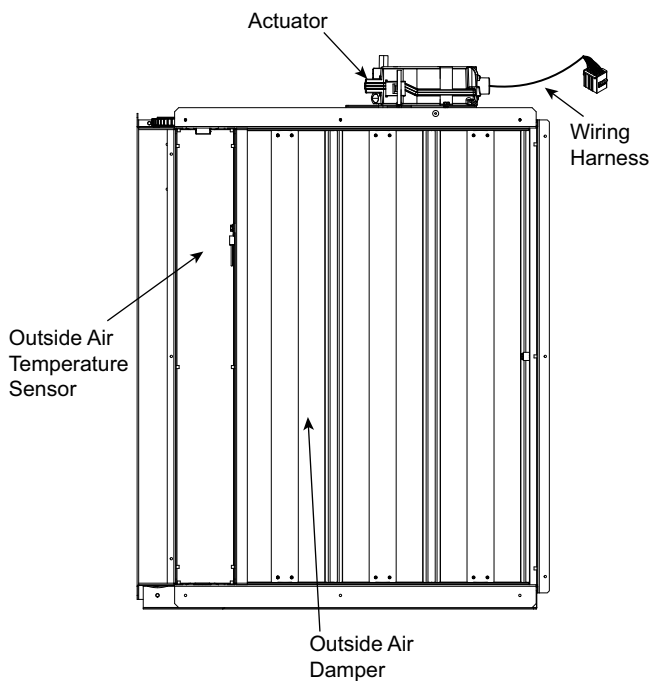

Fig. 68 – EconomizerONE Component Locations (CRECOMZR108A00 Shown)

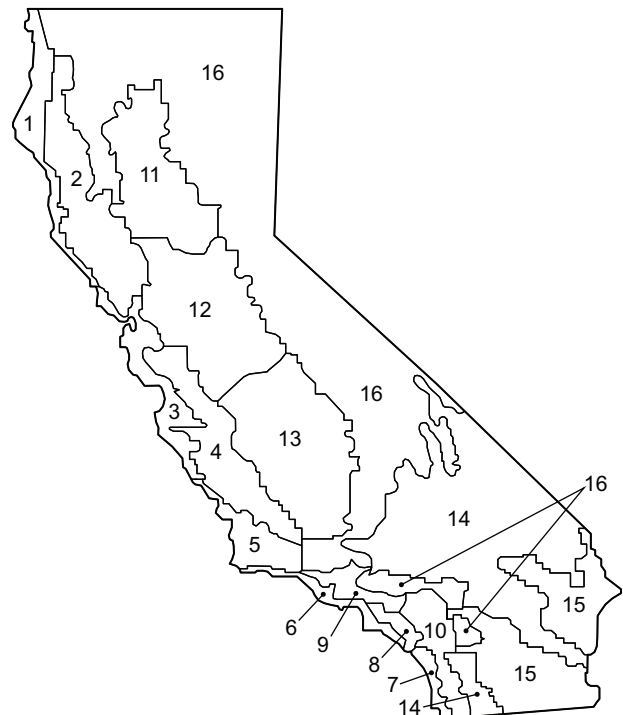

Fig. 69 – California Title 24 Zones

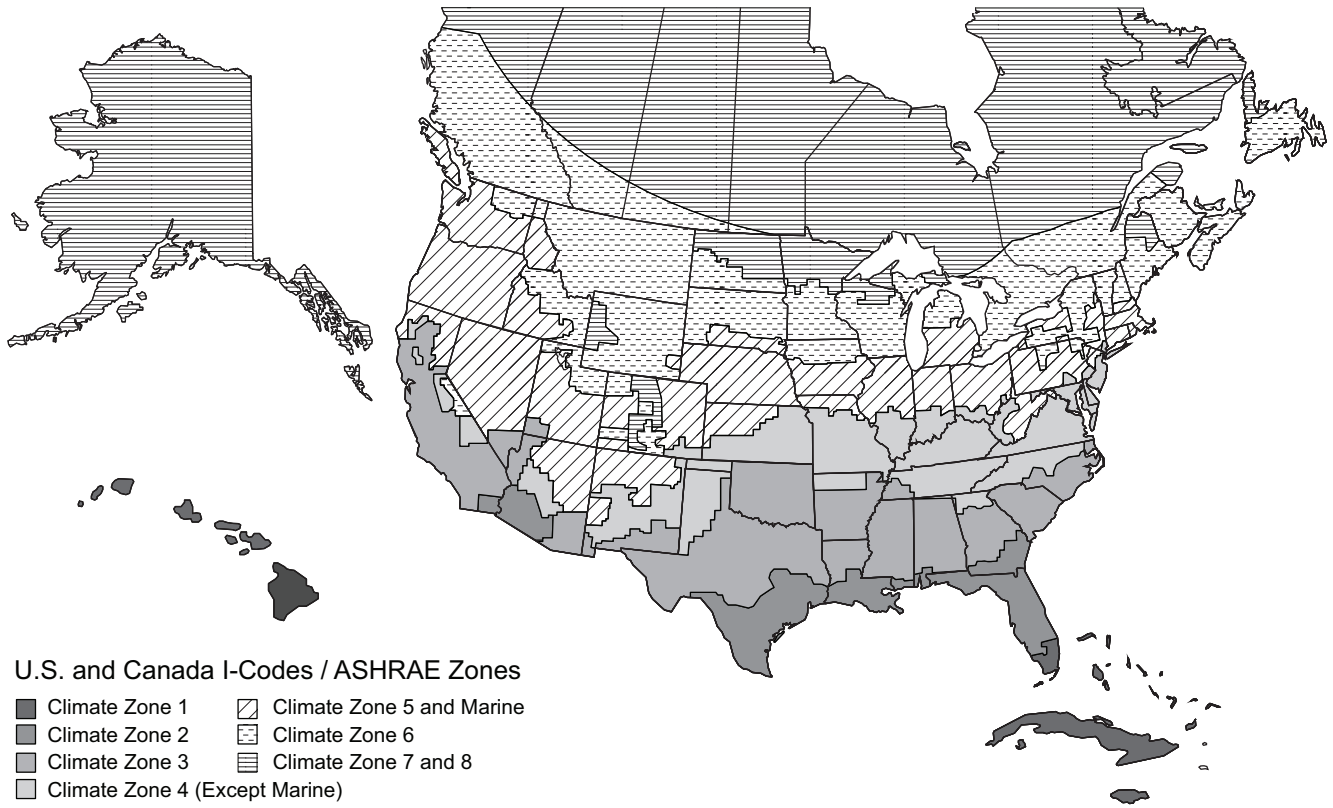

Fig. 70 – U.S. and Canada Climate Zones

Table 29 – Enthalpy Manual Entry Setpoints for EconomizerONE Per Climate Zone

CLIMATE ZONES ^a	2 TEMP OFF	LOWEST SETTING	RH%	2 ENTH OFF	RH%	2THL	2EHL	RH%
1	65°F	22 Btu/lbm	43%	28 Btu/lbm	86%	83°F	33 Btu/lbm	48%
2	65°F	22 Btu/lbm	43%	28 Btu/lbm	86%	83°F	33 Btu/lbm	48%
3	65°F	22 Btu/lbm	43%	28 Btu/lbm	86%	83°F	33 Btu/lbm	48%
4	65°F	22 Btu/lbm	43%	28 Btu/lbm	86%	83°F	33 Btu/lbm	48%
5	70°F	22 Btu/lbm	28%	28 Btu/lbm	65%	83°F	33 Btu/lbm	48%
6	70°F	22 Btu/lbm	28%	28 Btu/lbm	65%	83°F	33 Btu/lbm	48%
7 and 8	75°F	22 Btu/lbm	19%	28 Btu/lbm	50%	83°F	33 Btu/lbm	48%
CALIFORNIA TITLE 24 ZONES ^b	2 TEMP OFF	LOWEST SETTING	RH%	2 ENTH OFF	RH%	2THL	2EHL	RH%
1	75°F	22 Btu/lbm	19%	28 Btu/lbm	50%	83°F	33 Btu/lbm	48%
2	73°F	22 Btu/lbm	22%	28 Btu/lbm	55%	83°F	33 Btu/lbm	48%
3	75°F	22 Btu/lbm	19%	28 Btu/lbm	55%	83°F	33 Btu/lbm	48%
4	73°F	22 Btu/lbm	22%	28 Btu/lbm	55%	83°F	33 Btu/lbm	48%
5	75°F	22 Btu/lbm	19%	28 Btu/lbm	50%	83°F	33 Btu/lbm	48%
6	71°F	22 Btu/lbm	28%	28 Btu/lbm	62%	83°F	33 Btu/lbm	48%
7	69°F	22 Btu/lbm	32%	28 Btu/lbm	68%	83°F	33 Btu/lbm	48%
8	71°F	22 Btu/lbm	28%	28 Btu/lbm	62%	83°F	33 Btu/lbm	48%
9	71°F	22 Btu/lbm	28%	28 Btu/lbm	62%	83°F	33 Btu/lbm	48%
10	73°F	22 Btu/lbm	22%	28 Btu/lbm	55%	83°F	33 Btu/lbm	48%
11	75°F	22 Btu/lbm	19%	28 Btu/lbm	50%	83°F	33 Btu/lbm	48%
12	75°F	22 Btu/lbm	19%	28 Btu/lbm	50%	83°F	33 Btu/lbm	48%
13	75°F	22 Btu/lbm	19%	28 Btu/lbm	50%	83°F	33 Btu/lbm	48%
14	75°F	22 Btu/lbm	19%	28 Btu/lbm	50%	83°F	33 Btu/lbm	48%
15	75°F	22 Btu/lbm	19%	28 Btu/lbm	50%	83°F	33 Btu/lbm	48%
16	75°F	22 Btu/lbm	19%	28 Btu/lbm	50%	83°F	33 Btu/lbm	48%
CONTROLLER DEFAULT SETTINGS	2 TEMP OFF	—	—	2 ENTH OFF	—	2THL	2EHL	RH%
DEFAULT SET POINTS	63°F	—	—	28 Btu/lbm	94%	83°F	33 Btu/lbm	48%

NOTE(S):

- a. See Fig. 70 for map of U.S. and Canada climate zones.
- b. See Fig. 69 for map of California Title 24 zones.

Economizers are shipped standard with an HH79NZ039 outside air dry bulb sensor (see Fig. 67). System default setting (high temp limit) is 63°F (17°C) and has a range of 48°F to 80°F (9°C to 27°C). Sensor is factory installed on economizer.

NOTE: A second HH79NZ039 sensor is provided for mixed air temperature.

NOTE: California high temperature setting requirements by region are shown in Table 30.

Enthalpy Settings (Enthalpy Option)

If installing the optional HH57LW001 enthalpy sensor, the HH79NZ039 dry bulb outside air sensor must first be removed. Wire sensor to harness 48TC005213 and the (5) wires from the harness to the EconomizerONE harness in the return air chamber. Harness 48TC005213 has a 5-pin plug that connects directly to the HH57LW001 enthalpy sensor. Refer to the base unit control wiring diagrams earlier in this book for wiring connections. Refer to Fig. 66 and Table 31.

California’s Title 24 High Temperature Limit Settings

California’s Title 24 code requires a high temperature limit setting for all dry bulb outside air economizer changeover. The temperatures vary by the region within California. See Table 30 for high limit settings.

Table 30 — California Title 24 Regional High Limit Dry Bulb Temperature Settings^a

DEVICE TYPE ^b	CLIMATE ZONES	REQUIRED HIGH LIMIT (ECONOMIZER OFF WHEN):
		DESCRIPTION
FIXED DRY BULB	1, 3, 5, 11-16	OAT exceeds 75°F (23.8°C)
	2, 4, 10	OAT exceeds 73°F (22.7°C)
	6, 8, 9	OAT exceeds 71°F (21.6°C)
	7	OAT exceeds 69°F (20.5°C)
DIFFERENTIAL DRY BULB	1, 3, 5, 11-16	OAT exceeds RA temperature
	2, 4, 10	OAT exceeds return air temperature -2°F (-18.8°C)
	6, 8, 9	OAT exceeds return air temperature -4°F (-20°C)
	7	OAT exceeds return air temperature -6°F (-21.1°C)
FIXED ENTHALPHY ^c + FIXED DRY BULB	All	OAT exceeds 28 Btu/lb of dry air ^b or OAT exceeds 75°F (23.8°C)

NOTE(S):

- a. This table sourced from 2019 California Energy Code, Title 24, Part 6, Table 140.4-E Air Economizer High Limit Shut Off Control Requirements.
- b. Only the high limit control devices listed are allowed to be used and at the set points listed. Others such as Dew Point, Fixed Enthalpy, Electronic Enthalpy, and Differential Enthalpy Controls, may not be used in any climate zone for compliance with Section 140.4(e)1 unless approval for use is provided by the Energy Commission Executive Director.
- c. At altitudes substantially different than sea level, the Fixed Enthalpy limit value shall be set to the enthalpy value at 75°F and 50% relative humidity. As an example, at approximately 6,000 foot elevation, the fixed enthalpy limit is approximately 30.7 Btu/lb.

LEGEND

- OAT — Outdoor-air Thermostat
- RA — Return Air

Table 31 — HH57LW001 Sensor Wiring Terminations

TERMINAL		TYPE	DESCRIPTION
NUMBER	LABEL		
1	TCOM	NTC 10k	Outside Air Temperature Sensor Output
2	TSIG	NTC 10k	Outside Air Temperature Sensor Output
3	HSIG	0-10 vdc	Outside Air Relative Humidity Sensor Output
4	HCOM	COMMON	Sensor 24-v Common Input
5	H24V	24 vac	Sensor 24-v Operating Voltage Input

CHECKOUT

Inspect all wiring connections at the economizer module's terminals, and verify compliance with the installation wiring diagrams. For checkout, review the Status of each configured parameter and perform the Test Commands tests (refer to Table 26).

For information about menu navigation and use of the keypad see Interface Overview on page 33.

WARNING

ELECTRIC SHOCK HAZARD

Failure to follow this warning could result in personal injury, property damage, or death.

Before performing service or maintenance operations on unit, always turn off main power switch to unit and install lock(s) and lockout tag(s). Unit may have more than one power switch. Ensure electrical service to rooftop unit agrees with voltage and amperage listed on the unit rating plate.

If any wiring changes are required, first be sure to remove power from the economizer module before starting work. Pay particular attention to verifying the power connection (24 vac).

Power Up

After the POL224 module is mounted and wired, apply power.

Initial Menu Display

On initial start up, "Welcome" displays on the economizer HMI screen. After a brief pause, the Parameter Settings — I/O Configuration (refer to Table 24) of the software appears, allowing the user to check that presets and default values are configured correctly.

Power Loss (Outage or Brownout)

All set points and advanced settings are restored after any power loss or interruption.

NOTE: All settings are stored in non-volatile flash memory.

Status

Use the Status menu (refer to Table 21) to check the parameter values for the various devices and sensors configured.

NOTE: For information about menu navigation and use of the keypad, see Interface Overview on page 33.

Checkout Tests

Use the Test Commands menu (refer to Table 26) to test the damper operation and any configured outputs. Only items that are configured are shown in the Test Commands menu.

NOTE: For information about menu navigation and use of the keypad, see Interface Overview on page 33.

To perform a Test Command test:

1. Scroll to the desired test in Test Command menu 7 using the Up and Down buttons.
2. Press the Enter button to select the item. RUN? appears.
3. Press the Enter button to start the test. The unit pauses and then displays IN PROGRESS. When the test is complete, DONE appears.
4. When all desired parameters have been tested, press Enter + Up to end the test.

The Checkout tests can all be performed at the time of installation or at any time during the operation of the system as a test that the system is operable.

CAUTION

EQUIPMENT DAMAGE HAZARD

Failure to follow this caution may result in equipment damage.

Be sure to allow enough time for compressor start-up and shutdown between checkout tests so that you do not short-cycle the compressors.

TROUBLESHOOTING

For EconomizerONE troubleshooting issues see Table 32.

Table 32 – Operating Issues and Concerns

SYMPTOM	REASON	SOLUTION
An alarm is displayed on the LCD	Sensor, damper, or the whole working system may not work properly	Check sensor, damper, or the whole working system following the detailed alarm information.
DAC LED is blinking RED	Damper slippage	Check whether the damper works properly.
DAC LED is blinking RED quickly	Damper unplugged	Check whether the damper is connected.
DAC LED is OFF	Terminal ACT-FB is configured but there is no available feedback signal	Check whether the feedback signal is connected; check if ACT-FB is faulty.
Economizer controller has no alarm, but the Free Cooling LED will not turn on when the OA seems to be suitable for Free Cooling	Shutoff SP setting error	Shutoff temperature and/or enthalpy set point is incorrectly set up. Consult an HVAC professional to set up the shutoff set point correctly.
	OA temp is too low	The OA temperature is too low; therefore, there is no cooling demand. This could possibly enable anti-freeze protection.
	OA temp is too high or too humid	In DIFF mode, even though OA temperature is lower than RA temperature, if both OA and RA temperatures exceed the high limit, then Free Cooling turns off. In Differential Enthalpy control mode, even though OA enthalpy is lower than RA enthalpy, if both OA and RA enthalpy exceed the high limit, then Free Cooling turns off.
Economizer controller/mechanical cooling is not operating	No input power	Use a multi-meter to check whether there is 24 vac ± 25% (18-30 vac) at the POWER terminals. If there is no voltage or if the voltage is significantly low, then check the transformer output voltage at the RTU. If 24-v is not present at the transformer secondary side, then check the primary line voltage to the transformer. If the line voltage is not present at the transformer primary side, then check the primary power to the RTU, fuses, circuit breaker, and so on.
	Brownout	If voltage is below 17-v, then the economizer controller may be in Brownout Protection mode. This mode disables all of the relay outputs. When the power is 19 vac or higher, the economizer controller and RTU operate normally.
	Y1/Y2 signal is missing from the thermostat	Mechanical cooling does not run until there is cooling demand (Y1/Y2 Active). Check the wiring from Y11 and Y21 terminals to the commercial thermostat. 24-v should be present between Y11/Y21 and Y10/Y20 respectively.
	24 vac~ and 24 vac ⊥ are incorrectly wired	24 vac power supply has polarity when all devices are powered by the same 24 vac transformer; reversing polarity may cause a short circuit that can damage the system. Follow the transformer polarity mark, check the wiring of 24-v~ (or G or 24-v+), and ensure that they are tied to the same polar of 24 vac power supply; while checking the wiring of ⊥ (or G0 or 24-v- or COM), ensure that they are all tied to another polar of 24 vac power supply.
Firmware update failure	Application file is damaged, operation is incorrect, and/or USB flash disk does not work properly	Reload a BIN file, restart the controller, update firmware ^a , or change a USB flash disk. Contact service provider if failure still exists.
Free Cooling LED is solid RED	Sensor, damper, or whole working system may not work properly	Check sensor, damper, or the whole working system following the detailed alarm information.
Free Cooling LED is blinking RED	Not economizing when it should	Check the whole economizer working system, such as the sensor, damper, and thermostat.
Incorrect controller password error on mobile application	For CO ₂ and single enthalpy (control mode 3) configurations from the factory, the password has changed	For units coming from the factory with CO ₂ configuration or single enthalpy (control mode 3), use the controller password OneBT2.1. For all other units, use the controller password OneBT. Performing a factory reset on the controller will also reset the password to OneBT.
RS485 communication failure	RS485 signal or configuration error	Check wiring, configuration, Baud Rate (using mobile application), and other network communication parameters.
Sensor LED is blinking RED	Excess outdoor air	Check the whole economizer working system, such as the sensor, damper, and thermostat.
Sensor LED is solid RED	Mixed Air (MA) sensor error	Check the MA sensor. It must be either a Type II NTC 10K or 0-10 vdc sensor.
	Outside Air (OA)/Return Air (RA) sensor error	Check the wiring and signal of the OA sensor. If in Differential (DIFF) mode, also check the RA sensor. The following sensor signals are valid: Type II NTC 10K or 0-10 vdc temperature. 0-10 vdc or 4-20 mA humidity.
	Air temperature failure/fault	Check the air temperature sensor signal. The valid signal must be Type II NTC 10K or 0-10 vdc.
Sensor LED is OFF	CO ₂ sensor error	Check CO ₂ sensor connection, sensor signal (under range or over range), and sensor signal type.
Sensor LED is YELLOW	Humidity sensor error	Check humidity sensor connection, sensor signal (under range or over range), and sensor signal type.
Wi-Fi connection failure	Wi-Fi/WLAN stick error or wrong user name and password	Unplug and re-plug in the Wi-Fi/WLAN stick, enter a correct user name and password, restart the controller, or replace the Wi-Fi/WLAN stick. If the Wi-Fi/WLAN stick is POL903.00/100, then the default user name and password are Siemens-WLAN-Stick and SIBPAdmin. DNS name is siemens.wlanstick. Contact Application Engineering for information on this accessory.

NOTE(S):

- a. Back up configurations before firmware update. All the previous configuration data is erased after firmware update. Contact Application Engineering for more information on support for firmware.
IMPORTANT: If the controller enters the configuration state for the convenience of I/O configurations, then users can manually switch to the running state after finishing configurations. To do so, press Enter + Up at the same time, then press Enter to confirm the switch after 8RUN STATE appears on the LCD.

SystemVu™ Controller (Factory Option)

For details on operating 48FE(G/H)04-06 units equipped with the factory-installed SystemVu controller option, refer to the *FE/GE Series Single Package Rooftop Units with SystemVu Controller Controls, Start-up, Operation and Troubleshooting manual*.

Controller Options

LOW AMBIENT

If the unit comes with electromechanical (EM) controls, then no adjustment is necessary.

If the unit comes with the SystemVu™ controller option, then refer to its installation control manual for details on adjusting “Cooling Lock-Out” setting and configure for the specific job requirements.

Smoke Detectors

Smoke detectors are available as factory-installed options on 48FE(G/H) models. Smoke detectors may be specified for supply air only, for return air without or with economizer, or in combination of supply air and return air. Return-air smoke detectors are arranged for vertical return configurations only. All components necessary for operation are factory-provided and mounted. The unit is factory-configured for immediate smoke detector shutdown operation; additional wiring or modifications to unit terminal board may be necessary to complete the unit and smoke detector configuration to meet project requirements.

Units equipped with factory-optional return-air smoke detectors require a relocation of the sensor module at unit installation. See Fig. 71 for the as-shipped location.

Completing Return Air Smoke Sensor Installation

1. Unscrew the 2 screws holding the return air smoke detector assembly. See Fig. 72, Step 1. Save the screws.
2. Turn the assembly 90 degrees and then rotate end to end. Make sure that the elbow fitting is pointing down. See Fig. 72, Step 2.

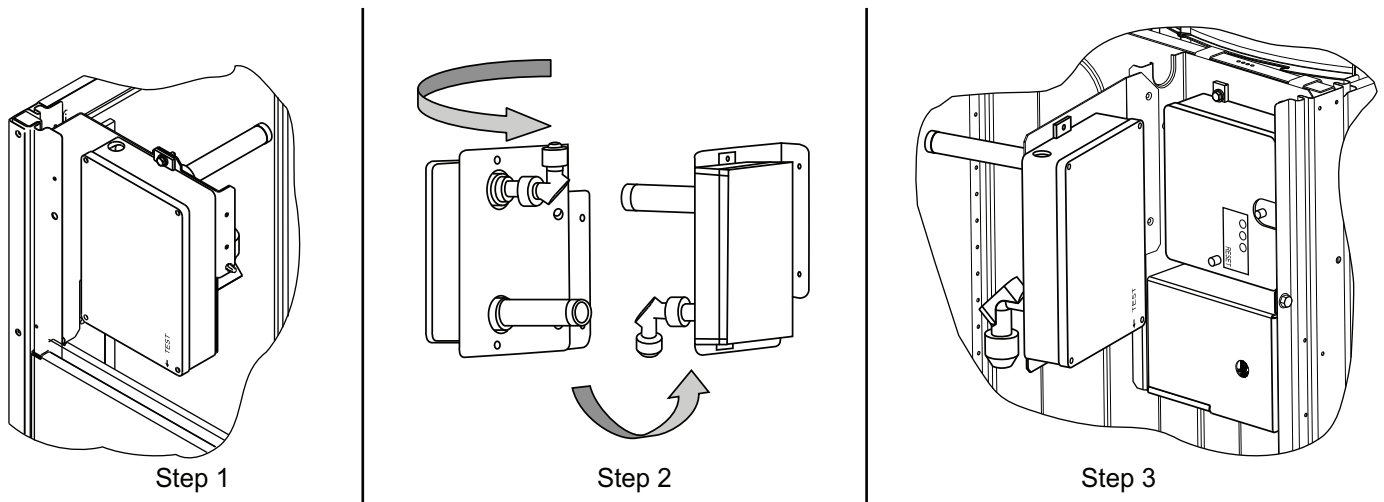

Fig. 72 — Completing Installation of Return Air Smoke Sensor

3. Screw the sensor and detector plate into its operating position using screws from Step 1. See Fig. 72, Step 3.
4. Connect the flexible tube on the sampling inlet to the sampling tube on the basepan.

Additional Application Data

Refer to the application data document “Factory Installed Smoke Detectors for Small and Medium Rooftop Units 2 to 25 Tons” for discussions on additional control features of these smoke detectors including multiple unit coordination.

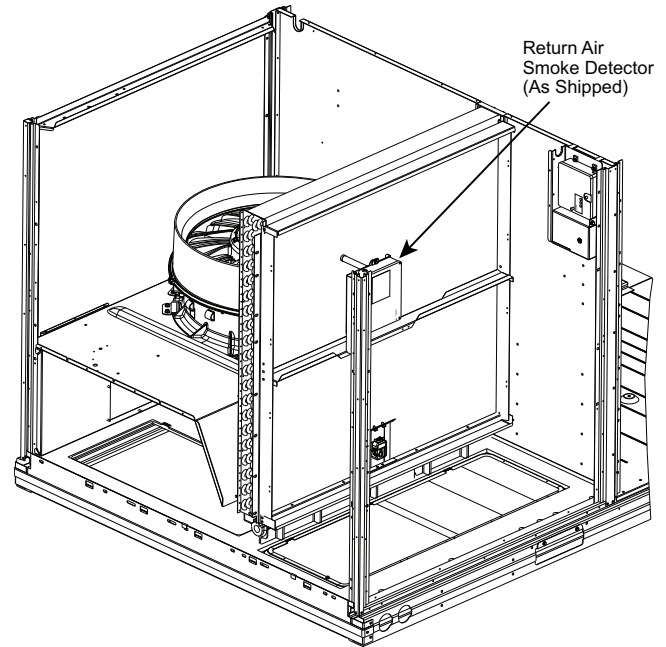

Fig. 71 — Return Air Smoke Detector, Shipping Position

Step 14 — Adjust Factory-Installed Options

SMOKE DETECTORS

Smoke detector(s) will be connected at the Unit Control Board (UCB), at terminals marked “Smoke Shutdown.” Detach the jumper covering the Smoke Shutdown terminals on the UCB and then attach the wiring harness from the smoke detector.

ECONOMIZERONE OCCUPANCY SWITCH

External occupancy control is managed through a connection on the Unit Control Board.

If external occupancy control is desired, connect a time clock or remotely controlled switch (closed for Occupied, open for Unoccupied sequence) at terminals marked OCCUPANCY. Detach the jumper covering the “Occupancy” terminals on the UCB and then attach the required connections.

Step 15 — Install Accessories

Available accessories include:

- Roof curb
- Thru-base connection kit (must be installed before unit is set on roof curb)
- Flue discharge deflector
- Manual outside air damper
- Two-position motorized outside air damper
- EconomizerONE (with POL224 control)
- Power Exhaust
- Differential dry-bulb sensor
- Outdoor enthalpy sensor
- Differential enthalpy sensor
- CO₂ sensor
- Louvered hail guard
- Phase monitor control

Refer to separate installation instructions for information on installing these accessories.

Step 16 – Fan Speed Set Up

UNITS WITH ELECTROMECHANICAL CONTROLS

The fan speed set up controls are located on the lower section of the Unit Control Board (UCB). See Fig. 73 for the location on 3-phase voltage units or Fig. 74 for the location on single phase voltage units.

1. Check the job specifications for the cfm (cubic feet per minute) and ESP (external static pressure) required.
2. Using the chart on the Fan Speed Set Up labels (see Fig. 76), calculate the vdc from the cfm and ESP for the base unit. Then add vdc for any accessories installed per the “Field Accessories” section of the label.

NOTE: The Fan Speed Set Up labels are located on the High Voltage cover in the Control Box.

3. Connect a multimeter to the vdc terminals on the UCB.
4. Set the Range Switch to either A, B, or C per the Switch Range table.
5. Using a straight blade screwdriver, turn the vdc control dial to fine tune the vdc reading.
6. Record the reading in the Field Setting field.

NOTE: Fan set-up vdc is not affected by the operating stage of the unit.

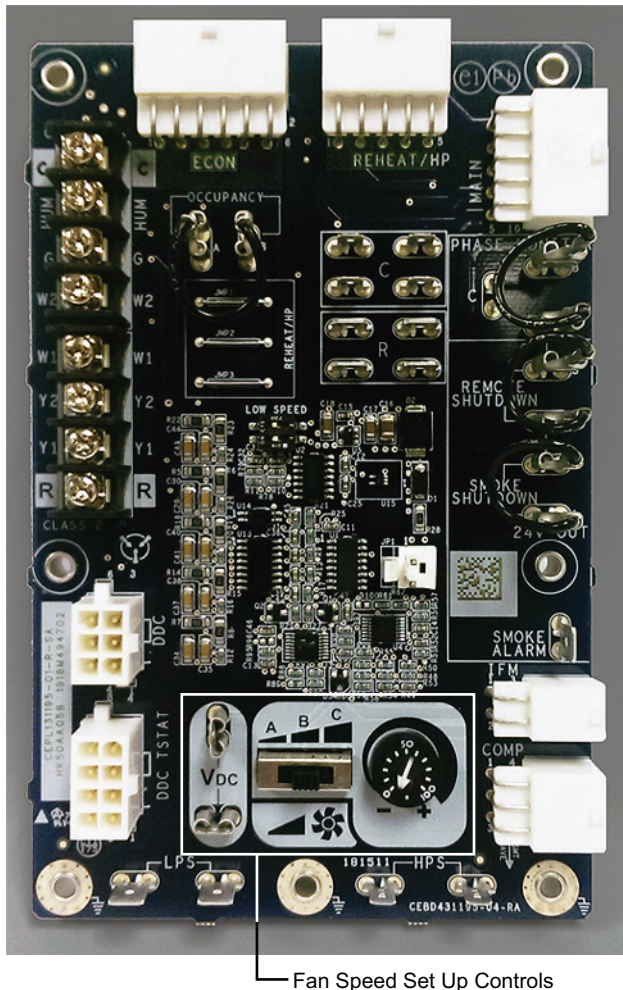

Fig. 73 – UCB Fan Speed Controls – 3-Phase Units

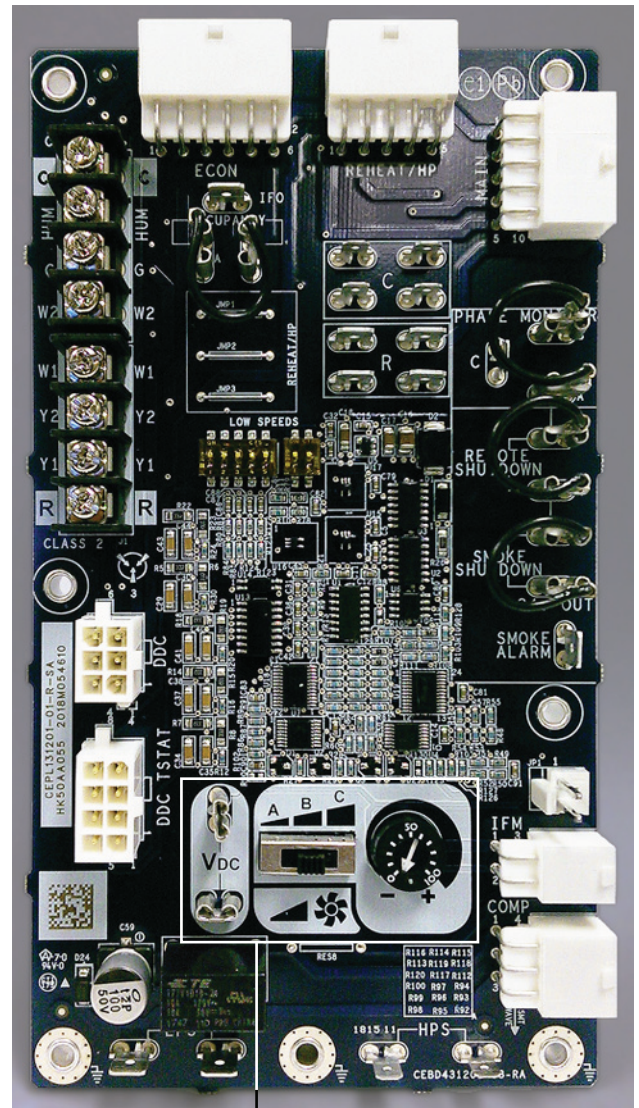

Fig. 74 – UCB Fan Speed Controls – Single Phase Units

NOTE: On single phase units, the approximate static pressure of the ductwork must be set for optimal unit efficiency. The unit is factory set for greater than 1.0 in. wg. If the external static pressure is less than 1.0 in. wg, slide switch 1 on the 5-pin DIP to the “ON” position. See Fig. 75.

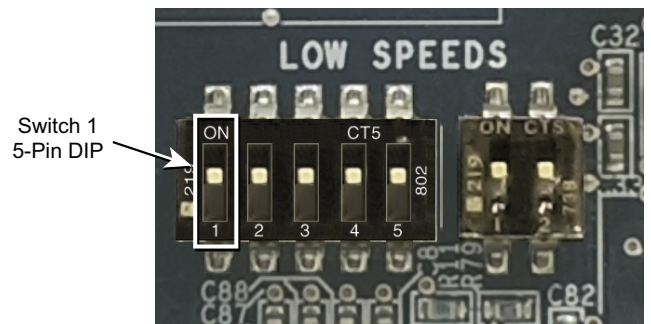
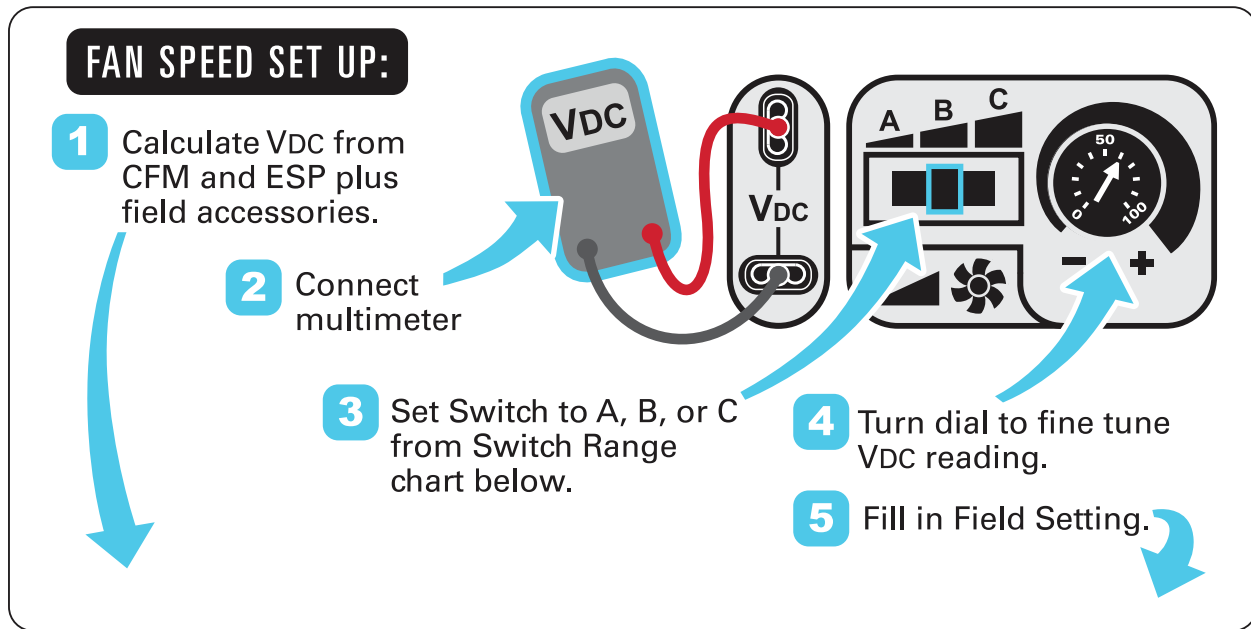

Fig. 75 – Detail – 5-Pin DIP Switch



Vdc Calculator		ESP in. wg										
		0.2	0.4	0.6	0.8	1.0	1.2	1.4	1.6	1.8	2.0	
UNIT MODEL NUMBER	CFM	1500	6.0	6.7	7.4	8.0	8.5	9.0	9.5	9.9		
		1625	6.3	7.1	7.7	8.3	8.8	9.3	9.7			
		1750	6.7	7.4	8.0	8.6	9.1	9.5	10.0			
		1875	7.1	7.7	8.3	8.9	9.4	9.8				
		2000	7.5	8.1	8.7	9.2	9.7					
		2125	7.9	8.4	9.0	9.5						
		2250	8.3	8.8	9.4	9.9						
		2375	8.7	9.2	9.7							
		2500	9.1	9.5								
		Field Accessories:										
	Economizer	0.1	0.1	0.1	0.1	0.1	0.1	0.1	0.1			

Factory Setting:
9.0 Vdc

Field Setting:
Record field setting here
_____ VDC

Switch Range: *

	A	B	C
A	4.1 - 7.5		
B	6.9 - 8.7		
C	7.7 - 10.0		

* Overlap in A, B, C switch range designed for maximum field adjustment potential. For example 7.2 can be set at either A or B.

Fig. 76 — Example of Fan Speed Set Up Labels for Electromechanical Controls

UNITS WITH SYSTEMVU™ CONTROLS

On units equipped with the factory-installed SystemVu controller, the Fan Speed settings are accessed through the SystemVu interface.

1. Check the job specifications for the cfm (cubic feet per minute) and ESP (external static pressure) required.
2. Using the chart on the Fan Speed Set Up labels (see Fig. 77), calculate the rpm from the cfm and ESP for the base unit plus any field accessories (as listed on the label).

NOTE: The Fan Speed Set Up labels are located on the High Voltage cover in the Control Box.

3. Press any key on the SystemVu interface to activate the display backlight and then press the MENU key.
4. Using the UP and DOWN arrow keys highlight SETTINGS and then press ENTER.
5. Use the DOWN arrow key highlight the UNIT CONFIGURATIONS menu then press ENTER.

6. Highlight UNIT CONFIGURATIONS then press ENTER.
7. Highlight INDOOR FAN and then press ENTER.
8. Refer to the job specifications to set the following, determining the values per the Rpm Calculator label (see Fig. 77). Use the UP and DOWN arrow keys and the BACK key to set the values. Press ENTER after setting each value to continue to the next selection.
 - IDF VENT SPD
 - IDF HEAT SPD
 - IDF LOW COOL SPD
 - IDF HIGH SPD
 - IDF FREE COOL SPD

For further details, see the *FC/GC Series Single Package Rooftop Units with SystemVu Controller Controls, Start-up, Operation and Troubleshooting* manual.

FAN SPEED SETUP (RPM)

MAIN MENU:

SETTINGS

↳ UNIT CONFIGURATIONS

↳ INDOOR FAN

- ↳ IDF VENT SPD -RPM
- ↳ IDF HEAT SPD -RPM
- ↳ IDF LOW COOL SPD -RPM
- ↳ IDF HIGH COOL SPD -RPM
- ↳ IDF FREE COOL SPD -RPM

↓ DETERMINE RPM FROM BELOW ↓

48TC003136 REV. A

RPM Calculator		ESP in. wg										
		0.2	0.4	0.6	0.8	1.0	1.2	1.4	1.6	1.8	2.0	
UNIT MODEL NUMBER	CFM	1500	1425	1609	1764	1902	2028	2147	2260	2367		
		1625	1512	1688	1839	1974	2097	2212	2322			
		1750	1601	1768	1916	2047	2168	2280	2387			
		1875	1692	1850	1994	2123	2241	2351				
		2000	1784	1933	2073	2200	2316					
		2125	1878	2018	2153	2277						
		2250	1973	2104	2235	2356						
		2375	2069	2192	2317							
		2500	2166	2282								
	Field Accessories:											
	Economizer	65	65	65	65	65	65	65	65			

Fig. 77 – Example of Fan Speed Set Up Labels for SystemVu™ Controls

FASTENER TORQUE VALUES

Table 33 details the torque values for the fasteners referenced in this installation instruction.

Table 33 – Fastener Torque Values

FASTENER	TORQUE VALUE
Heat shield screws	30 in.-lb (3.4 Nm) ±2 in.-lb (0.2 Nm)
Stator motor mounting screws	23 in.-lb (2.6 Nm) ±2 in.-lb (0.2 Nm)
Fan rotor mounting screws	23 in.-lb (2.6 Nm) ±2 in.-lb (0.2 Nm)
Limit switch screws	50 in.-lb (5.7 Nm) ±5 in.-lb (0.6 Nm)
Fan deck bracket screws	50 in.-lb (5.7 Nm) ±5 in.-lb (0.6 Nm)
Condenser fan motor mounting screws	30 in.-lb (3.4 Nm) ±3 in.-lb (0.3 Nm)
Condenser fan hub set screw	60 in.-lb (6.8 Nm) ±5 in.-lb (0.6 Nm)
Compressor mounting bolts	65 in.-lb (7.3 Nm) ±10 in.-lb (1.2 Nm)
Control box grounding lug	20 in.-lb (2.25 Nm) ±2 in.-lb (0.2 Nm)

START-UP CHECKLIST

48FE(G/H)*04-06 Single Package Rooftop Gas Heating/Electric Cooling Unit

(Remove and use for job file)

NOTE: To avoid injury to personnel and damage to equipment or property when completing the procedures listed in this start-up checklist, use good judgment, follow safe practices, and adhere to the safety considerations/information as outlined in preceding sections of this Installation Instruction document.

I. PRELIMINARY INFORMATION

MODEL NO. _____
JOB NAME _____
SERIAL NO. _____
ADDRESS _____
START-UP DATE _____
TECHNICIAN NAME _____
ADDITIONAL ACCESSORIES _____

II. PRE-START-UP

Verify that all packaging materials have been removed from unit. (Y/N) _____
Verify installation of outdoor air hood. (Y/N) _____
Verify installation of flue exhaust and inlet hood. (Y/N) _____
Verify that condensate connection is installed per instructions. (Y/N) _____
Verify that all electrical connections and terminals are tight. (Y/N) _____
Verify ground integrity with a continuity test. (Y/N) _____
Verify gas pressure to unit gas valve is within specified range. (Y/N) _____
Check gas piping for leaks. (Y/N) _____
Check that indoor-air filters are clean and in place. (Y/N) _____
Check that outdoor air inlet screens are in place. (Y/N) _____
Verify that unit is level. (Y/N) _____
Verify that fan assembly is free of obstructions and rotor spins freely. (Y/N) _____
Verify that scroll compressors are rotating in the correct direction. (Y/N) _____
Verify yellow LED light on dissipation board is steady. (Y/N) _____
Verify the dissipation board test button will operate the indoor fan for 1 minute. (Y/N) _____
Verify installation of thermostat. (Y/N) _____
Verify that crankcase heaters have been energized for at least 24 hours. (Y/N) _____

III. START-UP

ELECTRICAL

Supply Voltage	L1-L2 _____	L2-L3 _____	L3-L1 _____
Compressor Amps 1	L1 _____	L2 _____	L3 _____
Compressor Amps 2	L1 _____	L2 _____	L3 _____
Supply Fan Amps	L1 _____	L2 _____	L3 _____

Manufacturer reserves the right to discontinue, or change at any time, specifications or designs without notice and without incurring obligations.

V. TEMPORARY FURNACE OPERATION DURING CONSTRUCTION

The furnace may be operated during the finishing stage of construction. To ensure proper operation follow checklist below:

1. Prior to the finishing stage of construction, ensure that return air and vent openings are covered to minimize penetration of dust and construction debris into the unit (Y/N) _____
2. Interior drywall installation shall be completed and covered with paint or primer prior to unit operation (Y/N) _____
3. Premises shall be substantially free of debris and dust (Y/N) _____
4. Ensure all return and vent coverings have been removed (Y/N) _____
5. Verify the return ducts and supply ducts are connected, are free from obstructions, are clean, and are properly sealed (Y/N) _____
6. Ensure proper vent installation per installation instructions (Y/N) _____
7. Ensure gas piping has been connection per installation instructions (Y/N) _____
8. Verify that the gas piping is free of leaks (Y/N) _____
9. Furnace to be set to operate under appropriate control to ensure proper operation (Y/N) _____
10. Minimum MERV 11 air filters to be installed during the finishing stages of construction (Y/N) _____
11. Set furnace input rate and temperature rise per rating plate marking (Y/N) _____
12. Ensure means for providing combustion air in accordance with the manufacturer's shipped installation instructions (Y/N) _____
13. Return air temperature to be maintained between 55°F (13°C) and 80°F (27°C) (Y/N) _____
14. Furnace shall be set up to operate in accordance with installation instructions and shall be verified for operating conditions including ignition, input rate, temperature rise, and venting (Y/N) _____
15. Install new filters as per installation instructions prior to final occupancy (Y/N) _____

CUT ALONG DOTTED LINE

CUT ALONG DOTTED LINE