



Product Data

WeatherMaker® Single Packaged Rooftop 3 to 6 Nominal Tons

ecoblue™  technology



Puron
ADVANCE™

48/50FE**04, 05, 06, 07

48FE: Single-Package Gas Heating/Electric Cooling
Rooftop Units
50FE: Electric Cooling Rooftop Units with Accessory
Electric Heat
with Puron Advance™ Refrigerant (R-454B)

Carrier’s WeatherMaker® rooftop units (RTUs) with Puron Advance™ and EcoBlue™ Fan Technology offer an environmentally sustainable solution for a brighter future.

New major design features include:

- Environmentally balanced Puron Advance (R-454B) refrigerant, which delivers a 75% reduction in global warming potential (GWP) compared to the original Puron. Puron Advance’s GWP of 466 easily exceeds the EPA (Environmental Protection Agency) requirement of <700 GWP.
- A patented, industry-first vane axial indoor fan system with an electronically commutated motor for simplicity and efficiency. When compared to traditional belt-driven forward curve fans, our reliable system has:
 - 75% fewer moving parts
 - Up to 40% greater efficiency
 - No fan belts, pulleys, shaft, or shaft bearings
 - Better sound and comfort control due to slow ramp-up capability
 - Internal protection from phase reversal and phase loss situations
 - High external static capability
- Reliable single (04-06 sizes) or 2-stage (07 size) cooling designs with fully active evaporator coils

- Unit control board (UCB) with intuitive indoor fan adjustment that uses simple dial and switch configuration
- Reliable copper tube/aluminum fin condenser coil with 5/16 in. tubing to help reduce refrigerant charge and weight versus prior designs
- For 48FE Ultra Low NOx units ONLY (sizes 04-06 only and excluding 575-v units): Carrier-exclusive Ultra Low NOx gas heat emissions burner box and heat exchanger design that provides 14 nanograms/joule (ng/j) operation

Our WeatherMaker 48/50FE 3 to 6 ton units are specifically designed to fit on Carrier roof curbs installed as far back as 1989. That makes replacements fast and easy, eliminating the need for curb adapters or different utility connections.

Single-stage models deliver efficiencies of up to 13.4 SEER2, while two-stage models deliver efficiencies of up to 15.5 IEER. All models are field convertible and capable of either vertical or horizontal airflow.

With “no-strip” screw collars, handled access panels, and more, the unit is easy to install, easy to maintain, and easy to use. Your new 3 to 6 ton Carrier WeatherMaker RTU provides optimum comfort and control from a packaged rooftop.

Value-added features include:

- Optional Humidi-MiZer® adaptive dehumidification system for

improved part load humidity performance

- SystemVu™ intuitive, intelligent controls option that provides:
 - Large, full text, multi-line display
 - USB flash port for data transfer
 - Built in i-Vu®, CCN, and BACnet®¹
 - Easy-to-read refrigerant pressures shown via the display — no checking gauges
 - Quick LED Status for Run, Alert, and Fault
 - Conventional thermostat or sensor capabilities
 - Historical component runtime and starts
 - Supply air tempering
 - Network Service Tool compatibility
- Single point gas and electrical connections
- Fixed refrigerant metering devices on 3 to 5 ton models and TXV on 6 ton models
- Scroll compressors with internal line-break overload protection
- Easy-to-access tool-less filter door, filter tracks that tilt out for filter removal and replacement, and filter size consistency across units

1. Third-party trademarks and logos are the property of their respective owners.

Table of contents

	Page
Features/Benefits	2
Model Number Nomenclature	5
Capacity Ratings	7
Physical Data	11
Options and Accessories	18
Base Unit Dimensions	23
Accessory Dimensions	29
Performance Data	30
Fan Data	44
Electrical Data	101
Typical Wiring Diagrams	120
Sequence of Operation	136
Application Data	139
Guide Specifications — 48FE	141
Guide Specifications — 50FE	154

Easy to install

All 3 to 6 ton WeatherMaker units are field-convertible to horizontal airflow, which makes it easy to adjust to unexpected jobsite complications. Our units are light, making them easy to replace, and our standard integrated unit control board (UCB) has simple, fast, clearly labeled plug-in connection points that reduce installation time. Should a job need additional features, our large control box provides room to work and mount Carrier accessories.

Easy to maintain

With the EcoBlue vane axial fan system and a direct drive ECM motor, belts and pulleys are a thing of the past. Should an adjustment be necessary, it can easily be made via the UCB in the control box. For regular service activities, our easy-access handles provide a quick solution to all commonly accessed service panels, and our sloped, corrosion-resistant composite drain pan sheds water and will not rust. Service gauge connections are included on compressor suction/discharge lines and before and after the filter drier to monitor system operation during maintenance.

Easy to use

Carrier's re-designed unit control board puts all connections and troubleshooting points in one convenient place. Most low voltage connections use the same board and are easy to access. Setting up the fan is simple using an intuitive switch and rotary dial arrangement. Our rooftops have high and low-pressure switches, a filter drier, and 2-in. filters standard.

For 48FE Ultra Low NOx units ONLY: the integrated gas control board operates an intelligent multi speed gas heat inducer motor to help reduce the ultra low NOx emissions. Note that:

1. Units cannot operate with Liquid Propane (LP) gas.
2. Units can operate from 0 to 7,800 feet altitude only.

Puron Advance™ Features

In 2018, Carrier announced Puron Advance (R-454B) as our next generation refrigerant for light commercial rooftops. With a GWP of 466 and similar working pressure and performance to R-410A, Puron Advance easily exceeds the EPA's new, stringent <700 GWP refrigerant requirement while minimizing unit redesign. Like other next generation refrigerants (R-32, etc.), R-454B is classified as an "A2L" refrigerant by ASHRAE (American Society of Heating, Refrigerating, and Air-Conditioning Engineers). This designation means that R-454B is "mildly flammable" under certain conditions. While this is a change from legacy "A1 — No Flame Propagation" refrigerants like Puron (R-410A), A2Ls are still very low on the flammability scale and quite safe for use. A2L refrigerants are difficult to ignite and have an extremely low flame speed — much less so than natural gas, propane, or even rubbing alcohol. At Carrier, we are committed to safety. As such, all of our Puron Advance rooftop units include a factory-installed dissipation control board and leak sensor designed to last the lifetime of the unit. This system is certified to UL 60335-2-40 and designed to work right away, without any field configuration or wiring. In the event of a leak, these systems automatically identify and

resolve the issue by safely dissipating the refrigerant to ensure there is no risk to equipment, buildings, or occupants.

EcoBlue™ Technology

Our direct drive EcoBlue indoor fan system uses a vane axial fan and electronically commutated motor. The benefit is clear: when compared to legacy belt drive systems, this vane axial design has 75% fewer moving parts, uses up to 40% less energy, and has no belts, blower bearings, or shaft.

Streamlined control and integration

Carrier controllers make connecting WeatherMaker rooftops to existing building automation systems easy. The units are compatible with conventional thermostat controls, SystemVu controls, and third-party building management systems (BMS).

Operating efficiency and flexibility

The 48/50FE rooftops meet ASHRAE 90.1 and IECC^{®1} (International Energy Conservation Code) minimum efficiency requirements.

Comfort control

Carrier's patented Humidi-MiZer adaptive dehumidification system is an all-inclusive, factory-installed option on gas heating/electric cooling and electric cooling/electric heat models. This system provides reliable, flexible operation to meet indoor part load sensible and latent requirements.

1. Third-party trademarks and logos are the property of their respective owners.

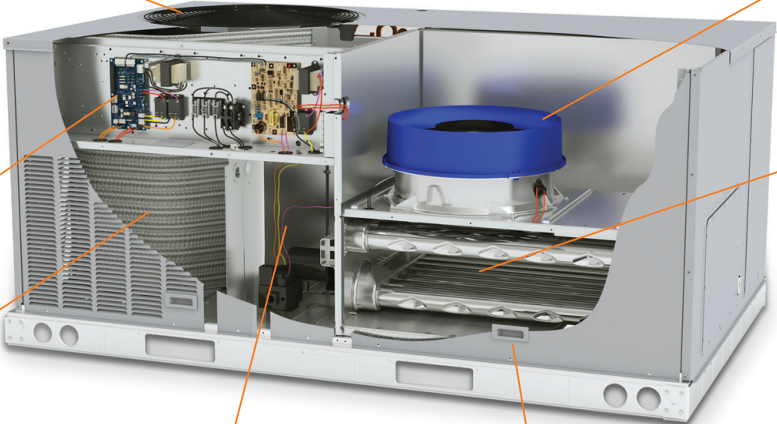

WeatherMaker
with **ecoblue**™ technology

- High Efficiency Outdoor Fan**
 - Non-corrosive blade
 - Balanced blade
 - Efficient airflow collar
- Unit controls**
 - Base unit controller
 - Switch/dial fan setting
 - Large terminal connections
 - SystemVu™ option
 - Large Display
 - Quick LED status
 - i-Vu®, CCN®, BACnet
- Efficient Coils**
 - Round tube/plate fin
 - Copper/Aluminum
 - Special coating available
 - New 5/16 in. condenser tube
 - Humidi-MiZer® system available
- Compression**
 - Fully hermetic scroll
 - Internally protected
 - Single stage (3 to 5 tons)
 - Two stage (6 tons)
- Cabinet Design**
 - Heavy gauge base rails
 - Large handled access panels
 - Tool-less filter access door
 - Replacement “original” fit design
- Vane Axial Indoor Fan**
 - Direct drive ECM
 - Slow ramp up
 - Phase loss protection
 - No belts or pulleys
- Heating**
 - Gas Heating
 - Induced draft heat exchanger
 - Multiple sizes available
 - Efficient dimpled gas design
 - Electric Heating
 - Multiple sizes available
 - Single point power

48FE Model Number Nomenclature

Position:	1	2	3	4	5	6	7	8	9	10	11	12	13	14	15	16	17	18
Example:	4	8	F	E	D	A	0	4	A	2	A	6	-	0	A	0	A	0

Unit Heat Type

48 = Gas Heat Packaged Rooftop

Model Series — WeatherMaker®

FE = Entry Tier Puron Advance™

Heat Size

D = Low Gas Heat
 E = Medium Gas Heat
 F = High Gas Heat
 G = Ultra Low NOx, Low Heat^{a,b}
 H = Ultra Low NOx, High Heat^{a,b}
 L = Low NOx, Low Heat
 S = Low Heat with Stainless Steel Exchanger
 R = Medium Heat with Stainless Steel Exchanger
 T = High Heat with Stainless Steel Exchanger

Refrig. Systems Options

A = Std One Stage Cooling Models^a
 B = Std One Stage Cooling Models with Humidi-MiZer®^{a,c}
 M = Single Circuit, Two Stage Cooling Models^c
 N = Single Circuit, Two Stage Cooling Models with Humidi-MiZer^{c,d}

Cooling Tons

04 = 3 tons
 05 = 4 tons
 06 = 5 tons
 07 = 6 tons

Sensor Options

A = None
 B = Return Air (RA) Smoke Detector
 C = Supply Air (SA) Smoke Detector
 D = RA + SA Smoke Detector
 J = Condensate Overflow Switch
 K = Condensate Overflow Switch and RA Smoke Detector
 L = Condensate Overflow Switch and RA + SA Smoke Detectors
 M = Condensate Overflow Switch and SA Smoke Detector

Fan Options

2 = Standard/Medium Static — EcoBlue Vane Axial Fan
 3 = High Static — EcoBlue Vane Axial Fan
 5 = Standard/Medium Static — EcoBlue Vane Axial Fan and Filter Status Switch
 6 = High Static — EcoBlue Vane Axial Fan and Filter Status Switch

Coil Options (Outdoor - Indoor — Hail Guard)

A = Al/Cu - Al/Cu
 B = Precoat Al/Cu - Al/Cu
 C = E-coat Al/Cu - Al/Cu
 D = E-coat Al/Cu - E-coat Al/Cu
 M = Al/Cu - Al/Cu — Louvered Hail Guard
 N = Precoat Al/Cu - Al/Cu — Louvered Hail Guard
 P = E-coat Al/Cu - Al/Cu — Louvered Hail Guard
 Q = E-coat Al/Cu - E-coat Al/Cu — Louvered Hail Guard
 R = Cu/Cu - Al/Cu — Louvered Hail Guard
 S = Cu/Cu - Cu/Cu — Louvered Hail Guard

Packaging & Seismic Compliance

0 = Standard

Electrical Options

A = None
 C = Non-Fused Disconnect (NFDC)
 D = Thru-the-Base (TTB) Connections
 F = Non-Fused Disconnect and TTB Connections
 N = Phase Monitor Protection (PMR)
 Q = PMR + NFDC
 R = PMR + TTB
 T = PMR + NFDC + TTB
 1 = HSCCR^d (High Short Circuit Current Rating)
 2 = HSCCR^d + TTB

Service Options

0 = None
 1 = Unpowered Convenience Outlet (NPCO)
 2 = Powered Convenience Outlet (PCO)
 3 = Hinged Panels (HP)
 4 = Hinged Panels + NPCO
 5 = Hinged Panels + PCO
 6 = MERV-13 Filters (M13)
 7 = NPCO + MERV-13 Filters
 8 = PCO + MERV-13 Filters
 9 = Hinged Panels + MERV-13 Filters
 A = HP + NPCO + MERV-13 Filters
 B = HP + PCO + MERV-13 Filters

Intake / Exhaust Options

A = None
 B = Standard Leak Economizer with Barometric Relief
 F = Standard Leak Enthalpy Economizer with Barometric Relief
 L = ULL (Ultra Low Leak) Temperature Economizer with Barometric Relief and CO₂ Sensor
 M = ULL Enthalpy Economizer with Barometric Relief and CO₂ Sensor
 U = ULL Temperature Economizer with Barometric Relief
 W = ULL Enthalpy Economizer with Barometric Relief

Base Unit Controls

0 = Electromechanical Controls (allows for use of field-installed economizers)
 3 = SystemVu™ Controls
 8 = Electromechanical Controls with POL224 EconomizerONE (with Fault Detection and Diagnostic)

Design Revision

- = Factory Design Revision

Voltage

1 = 575-3-60
 3 = 208/230-1-60^{a,f}
 5 = 208/230-3-60
 6 = 460-3-60

NOTE(S):

- ^a Size 04/05/06 models only.
- ^b Not available on 575-v units.
- ^c Units with Humidi-MiZer System include Low Ambient controller.
- ^d Size 07 models only.
- ^e HSCCR is not available on units with: Humidi-MiZer System, Powered Convenience Outlet, Phase Loss Monitor, Non-Fused Disconnect, or 575-v.
- ^f The following are not available as a factory-installed options for models with this voltage code: Humidi-MiZer System, Coated Coils or Cu Fin Coils, Louvered Hail Guards, Economizer, Powered Convenience Outlet, or Upgraded MERV filters.

Model number nomenclature (cont)



50FE Model Number Nomenclature

Position:	1	2	3	4	5	6	7	8	9	10	11	12	13	14	15	16	17	18
Example:	5	0	F	E	-	A	0	4	A	2	A	6	-	0	A	0	A	0

Unit Heat Type

50 = Cooling Only Packaged Rooftop with Optional Electric Heat

Model Series — WeatherMaker®

FE = Entry Tier Puron Advance™

Heat Size

- = No Heat
(Field Installed Available)

Refrig. Systems Options

A = Std One Stage Cooling Models^a
 B = Std One Stage Cooling Models with Humidi-MiZer®^{a, b}
 M = Single Circuit, Two Stage Cooling Models^c
 N = Single Circuit, Two Stage Cooling Models with Humidi-MiZer^{b, c}

Cooling Tons

04 = 3 tons
 05 = 4 tons
 06 = 5 tons
 07 = 6 tons

Sensor Options

A = None
 B = Return Air (RA) Smoke Detector
 C = Supply Air (SA) Smoke Detector
 D = RA + SA Smoke Detector
 J = Condensate Overflow Switch
 K = Condensate Overflow Switch and RA Smoke Detector
 L = Condensate Overflow Switch and RA + SA Smoke Detectors
 M = Condensate Overflow Switch and SA Smoke Detector

Fan Options

2 = Standard/Medium Static — EcoBlue Vane Axial Fan
 3 = High Static — EcoBlue Vane Axial Fan
 5 = Standard/Medium Static — EcoBlue Vane Axial Fan and Filter Status Switch
 6 = High Static — EcoBlue Vane Axial Fan and Filter Status Switch

Coil Options (Outdoor - Indoor — Hail Guard)

A = Al/Cu - Al/Cu
 B = Precoat Al/Cu - Al/Cu
 C = E-coat Al/Cu - Al/Cu
 D = E-coat Al/Cu - E-coat Al/Cu
 M = Al/Cu - Al/Cu — Louvered Hail Guard
 N = Precoat Al/Cu - Al/Cu — Louvered Hail Guard
 P = E-coat Al/Cu - Al/Cu — Louvered Hail Guard
 Q = E-coat Al/Cu - E-coat Al/Cu — Louvered Hail Guard
 R = Cu/Cu - Al/Cu — Louvered Hail Guard
 S = Cu/Cu - Cu/Cu — Louvered Hail Guard

^a Size 04/05/06 models only.

^b Units with Humidi-MiZer System include Low Ambient controller.

^c Size 07 models only.

^d HSCCR is not available on units with: Humidi-Mizer, Phase Loss Monitor, Non-Fused Disconnect, Powered Convenience Outlet, Low Ambient Controls, or 575-v.

^e The following are not available as a factory-installed options for models with this voltage code: Humidi-MiZer System, Coated Coils or Cu Fin Coils, Louvered Hail Guards, Economizer, Powered Convenience Outlet, or Upgraded MERV filters.

Packaging & Seismic Compliance

0 = Standard

Electrical Options

A = None
 C = Non-Fused Disconnect (NFDC)
 D = Thru-the-Base (TTB) Connections
 F = Non-Fused Disconnect and TTB Connections
 N = Phase Monitor Protection (PMR)
 Q = PMR + NFDC
 R = PMR + TTB
 T = PMR + NFDC + TTB
 1 = HSCCR^d (High Short Circuit Current Rating)
 2 = HSCCR^d + TTB

Service Options

0 = None
 1 = Unpowered Convenience Outlet (NPCO)
 2 = Powered Convenience Outlet (PCO)
 3 = Hinged Panels (HP)
 4 = Hinged Panels + NPCO
 5 = Hinged Panels + PCO
 6 = MERV-13 Filters (M13)
 7 = NPCO + MERV-13 Filters
 8 = PCO + MERV-13 Filters
 9 = Hinged Panels + MERV-13 Filters
 A = HP + NPCO + MERV-13 Filters
 B = HP + PCO + MERV-13 Filters

Intake / Exhaust Options

A = None
 B = Standard Leak Economizer with Barometric Relief
 F = Standard Leak Enthalpy Economizer with Barometric Relief
 L = ULL (Ultra Low Leak) Temperature Economizer with Barometric Relief and CO₂ Sensor
 M = ULL Enthalpy Economizer with Barometric Relief and CO₂ Sensor
 U = ULL Temperature Economizer with Barometric Relief
 W = ULL Enthalpy Economizer with Barometric Relief

Base Unit Controls

0 = Electromechanical Controls (allows for use of field-installed economizers)
 3 = SystemVu™ Controls
 8 = Electromechanical Controls with POL224 EconomizerONE (with Fault Detection and Diagnostic)

Design Revision

- = Factory Design Revision

Voltage

1 = 575-3-60
 3 = 208/230-1-60^{a, e}
 5 = 208/230-3-60
 6 = 460-3-60

48FE*A 1-Phase AHRI Ratings^{a,b,c,d}

48FE UNITS	COOLING STAGES	NOMINAL CAPACITY (tons)	NET COOLING CAPACITY 2 (MBH)	TOTAL POWER 2 (kW)	SEER2	EER2	RATED INDOOR AIRFLOW (cfm)
*A04	1	3	34.0	3.0	13.4	11.5	1050
*A05	1	4	48.0	4.2	13.4	11.5	1500
*A06	1	5	57.5	5.0	13.4	11.4	1500

NOTE(S):

- Rated in accordance with AHRI Standards 210/240 (04-06 size).
- Rating are based on:
Cooling Standard: 80°F (27°C) db, 67°F (19°C) wb indoor air temperature and 95°F (35°C) db outdoor air temperature.
- Units comply with ASHRAE 90.1-2016 (American Society of Heating, Refrigerating, and Air-Conditioning Engineers) and DOE-2023 (Department of Energy) Energy Standard for minimum SEER2 and EER2 requirements.
- 48FE units comply with US Energy Policy Act (2005). To evaluate code compliance requirements, refer to state and local codes.

48FE*A/M 3-Phase AHRI Ratings^{a,b,c,d}

48FE UNITS	COOLING STAGES	NOMINAL CAPACITY (tons)	NET COOLING CAPACITY (MBH)	TOTAL POWER (kW)	SEER	EER
*A04	1	3	34.4	2.9	14.0	11.80
*A05	1	4	48.0	4.1	14.0	11.80
*A06	1	5	57.5	5.0	14.0	11.40
*M07	2	6	70.0	6.3	—	11.20

48FE UNITS	IEER WITH 2-SPEED INDOOR FAN MOTOR	NET COOLING CAPACITY 2 (MBH)	TOTAL POWER 2 (kW)	SEER2	EER2	RATED INDOOR AIRFLOW (cfm)
*A04	—	34.0	3.0	13.4	11.50	1050
*A05	—	48.0	4.2	13.4	11.50	1500
*A06	—	57.5	5.0	13.4	11.40	1500
*M07	15.0	—	—	—	—	2400

NOTE(S):

- Rated in accordance with AHRI Standards 210/240 (04-06 size) and 340/360 (07 size).
- Rating are based on:
Cooling Standard: 80°F (27°C) db, 67°F (19°C) wb indoor air temperature and 95°F (35°C) db outdoor air temperature.
IEER Standard: A measure that expresses cooling part-load EER efficiency for commercial unitary air-conditioning and heat pump equipment on the basis of weighted operation at various load capacities.
- Units comply with ASHRAE 90.1-2016 (American Society of Heating, Refrigerating, and Air-Conditioning Engineers) requirements, as well as DOE-2018 (Department of Energy) Energy Standard for minimum SEER and EER requirements and DOE-2023 Energy Standard for minimum SEER2 and EER2 requirements. ASHRAE 90.1 requires M1 ratings on 3-phase models.
- 48FE units comply with US Energy Policy Act (2005). To evaluate code compliance requirements, refer to state and local codes.

LEGEND

- AHRI** — Air-Conditioning, Heating and Refrigeration Institute
EER — Energy Efficiency Ratio
IEER — Integrated Energy Efficiency Ratio
MBH — Btuh in thousands
SEER — Seasonal Energy Efficiency Ratio

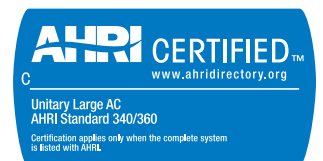

Capacity ratings (cont)



50FE-A 1-Phase AHRI Ratings^{a,b,c,d}

50FE UNITS	COOLING STAGES	NOM. CAPACITY (tons)	NET COOLING CAPACITY 2 (MBH)	TOTAL POWER 2 (KW)	SEER2	EER2	RATED INDOOR AIRFLOW (cfm)
-A04	1	3	34.0	3.0	13.4	11.50	1050
-A05	1	4	48.0	4.2	13.4	11.50	1500
-A06	1	5	57.5	5.0	13.4	11.40	1500

NOTE(S):

- Rated in accordance with AHRI Standards 210/240 (04-06 size).
- Rating are based on:
Cooling Standard: 80°F (27°C) db, 67°F (19°C) wb indoor air temperature and 95°F (35°C) db outdoor air temperature.
- Units comply with ASHRAE 90.1-2016 (American Society of Heating, Refrigerating, and Air-Conditioning Engineers) and DOE-2023 (Department of Energy) Energy Standard for minimum SEER2 and EER2 requirements.
- 50FE units comply with US Energy Policy Act (2005). To evaluate code compliance requirements, refer to state and local codes.

50FE-A/M 3-Phase AHRI Ratings^{a,b,c,d}

50FE UNITS	COOLING STAGES	NOMINAL CAPACITY (tons)	NET COOLING CAPACITY (MBH)	TOTAL POWER (kW)	SEER	EER
-A04	1	3	34.4	2.9	14.0	11.8
-A05	1	4	48.0	4.1	14.0	11.8
-A06	1	5	57.5	5.0	14.0	11.4
-M07	2	6	70.0	6.3	—	11.2

50FE UNITS	IEER WITH 2-SPEED INDOOR FAN MOTOR	NET COOLING CAPACITY 2 (MBH)	TOTAL POWER 2 (kW)	SEER2	EER2	RATED INDOOR AIRFLOW (cfm)
-A04	—	34.0	3.0	13.4	11.50	1050
-A05	—	48.0	4.2	13.4	11.50	1500
-A06	—	57.5	5.0	13.4	11.40	1500
-M07	15.5	—	—	—	—	2400

NOTE(S):

- Rated in accordance with AHRI Standards 210/240 (04-06 size) and 340/360 (07 size).
- Rating are based on:
Cooling Standard: 80°F (27°C) db, 67°F (19°C) wb indoor air temperature and 95°F (35°C) db outdoor air temperature.
IEER Standard: A measure that expresses cooling part-load EER efficiency for commercial unitary air-conditioning and heat pump equipment on the basis of weighted operation at various load capacities.
- Units comply with ASHRAE 90.1-2016 (American Society of Heating, Refrigerating, and Air-Conditioning Engineers) requirements, as well as DOE-2018 (Department of Energy) Energy Standard for minimum SEER and EER and DOE-2023 Energy Standards for minimum SEER2 and EER2 requirements. ASHRAE 90.1 requires M1 ratings on 3-phase models.
- 50FE units comply with US Energy Policy Act (2005). To evaluate code compliance requirements, refer to state and local codes.

LEGEND

- AHRI** — Air-Conditioning, Heating and Refrigeration Institute
EER — Energy Efficiency Ratio
IEER — Integrated Energy Efficiency Ratio
MBH — Btuh in thousands
SEER — Seasonal Energy Efficiency Ratio

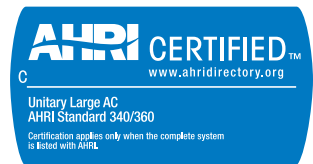

Sound Ratings Table

48/50FE UNIT	COOLING STAGES	OUTDOOR SOUND (dB) at 60 Hz ^{a,b}								
		A-Weighted ^c	63	125	250	500	1000	2000	4000	8000
**04	1	79	85.6	84.7	80.5	76.0	72.4	68.0	62.8	59.3
**05	1	79	85.6	84.7	80.5	76.0	72.4	68.0	62.8	59.3
**06	1	79	85.6	84.7	80.5	76.0	72.4	68.0	62.8	59.3
**07	2	79	85.6	84.7	80.5	76.0	72.4	68.0	62.8	59.3

NOTE(S):

- Outdoor sound data is measured in accordance with AHRI.
- Measurements are expressed in terms of sound power. Do not compare these values to sound pressure values because sound pressure depends on specific environmental factors which normally do not match individual applications. Sound power values are independent of the environment and therefore more accurate.
- A-weighted sound ratings filter out very high and very low frequencies, to better approximate the response of "average" human ear. A-weighted measurements for Carrier units are taken in accordance with AHRI.

LEGEND

db — Decibel

Minimum - Maximum Airflow Ratings (cfm) — Natural Gas and Propane

VOLTAGE	UNIT	HEAT LEVEL	COOLING				HEATING ^a	
			Minimum Airflow cfm	Minimum 2-Speed Airflow (Low Speed)	Minimum 2-Speed Airflow (High Speed)	Maximum Airflow cfm	Minimum Airflow cfm	Maximum Airflow cfm
1 PHASE	48FE**04	LOW	900	—	—	1500	890	1950
		MED	900	—	—	1500	800	1520
		HIGH	900	—	—	1500	—	—
	48FE**05	LOW	1200	—	—	2000	890	2440
		MED	1200	—	—	2000	1050	2280
		HIGH	1200	—	—	2000	1220	2170
	48FE**06	LOW	1500	—	—	2500	890	3250
		MED	1500	—	—	2500	1050	2730
		HIGH	1500	—	—	2500	1220	2790
3 PHASE	48FE**04	LOW	900	—	—	1500	910	2010
		MED	900	—	—	1500	960	1630
		HIGH	900	—	—	1500	—	—
	48FE**05	LOW	1200	—	—	2000	910	2010
		MED	1200	—	—	2000	1250	2330
		HIGH	1200	—	—	2000	1390	2220
	48FE**06	LOW	1500	—	—	2500	910	2510
		MED	1500	—	—	2500	1250	2720
		HIGH	1500	—	—	2500	1390	2780
	48FE**07	LOW	1800	1200	1800	3000	910	3350
		MED	1800	1200	1800	3000	1250	3260
		HIGH	1800	1200	1800	3000	1390	3170

NOTE(S):

- Heating rating values are identical for aluminum heat exchangers and stainless steel heat exchangers.

Minimum - Maximum Airflow Ratings (cfm) — 48FE Ultra Low NOx Units

48FE ULTRA LOW NOx UNIT SIZE	HEAT LEVEL	COOLING				ULTRA LOW NOx HEATING	
		Minimum Airflow cfm	Minimum 2-Speed Airflow (Low Speed)	Minimum 2-Speed Airflow (High Speed)	Maximum Airflow cfm	Minimum Airflow at 300 cfm/ton	Maximum Airflow at 300 cfm/ton
04	LOW	900	—	—	1500	900	1500
	MED	900	—	—	1500	1030	1500
05	LOW	1200	—	—	2000	1200	2000
	MED	1200	—	—	2000	1200	2000
06	LOW	1500	—	—	2500	1500	2500
	MED	1500	—	—	2500	1500	2500

Minimum - Maximum Airflow Ratings (cfm) — Cooling Units and Accessory Electric Heat

50FE UNIT SIZE	COOLING				ELECTRIC HEAT ^a	
	Minimum Airflow cfm	Minimum 2-Speed Airflow (Low Speed)	Minimum 2-Speed Airflow (High Speed)	Maximum Airflow cfm	Minimum Airflow cfm	Maximum Airflow cfm
*04	900	—	—	1500	900	1500
*05	1200	—	—	2000	1200	2000
*06	1500	—	—	2500	1500	2500
*07	1800	1200	1800	3000	1800	3000

NOTE(S):

a. Electric heat modules are available as field-installed accessories for 50FE units.

Heat Rating Table — Natural Gas and Propane

48FE UNIT	GAS HEAT	AL/SS HEAT EXCHANGER		TEMPERATURE RISE (°F)	THERMAL EFFICIENCY (%)	AFUE EFFICIENCY (%)	
		Input/Output Stage 1 (MBH)	Input/Output Stage 2 (MBH)				
1 PHASE	04	LOW	—	65/53	25-55	81	81
		MED	—	90/73	45-85	82	81
		HIGH	—	—	—	—	—
	05	LOW	—	65/53	20-55	81	81
		MED	—	90/73	30-65	82	81
		HIGH	—	130/106	45-80	81	81
	06	LOW	—	65/53	15-55	81	81
		MED	—	90/73	25-65	82	81
		HIGH	—	130/106	35-80	81	81
3 PHASE	04	LOW	—	67/54	25-55	81	—
		MED	82/65	110/88	50-85	80	—
		HIGH	—	—	—	—	—
	05	LOW	—	67/54	25-55	81	—
		MED	—	110/88	35-65	80	—
		HIGH	120/96	150/120	50-80	80	—
	06	LOW	—	67/54	20-55	81	—
		MED	—	110/88	30-65	80	—
		HIGH	120/96	150/120	40-80	80	—
	07	LOW	—	67/54	15-55	81	—
		MED	—	110/88	25-65	80	—
		HIGH	120/96	150/120	35-80	80	—

Heat Rating Table — Ultra Low NOx

48FE ULTRA LOW NOx UNIT	GAS HEAT	INPUT/OUTPUT (MBH)	TEMPERATURE RISE (°F)	THERMAL EFFICIENCY (%)	AFUE EFFICIENCY (%)	
1 PHASE	04	LOW	60 / 49	20-50	81	82
		MED	82 / 66	20-60	81	81
	05	LOW	60 / 49	20-50	81	82
		MED	82 / 66	20-60	81	81
	06	LOW	60 / 49	15-45	81	82
		MED	82 / 66	20-60	81	81
3 PHASE	04	LOW	60 / 49	20-50	81	—
		MED	82 / 66	20-60	81	81
	05	LOW	60 / 49	20-50	81	—
		MED	82 / 66	20-60	81	81
	06	LOW	60 / 49	15-45	81	—
		MED	82 / 66	20-60	81	81

48/50FE 3 and 4 Ton Units Physical Data

48/50FE UNIT	48/50FE*A04	48/50FE*B04	48/50FE*A05	48/50FE*B05
NOMINAL TONS	3	3	4	4
BASE UNIT OPERATING WT (lb) 48/50FE^a	482/437	482/437	543/498	543/498
REFRIGERATION SYSTEM				
No. Circuits/No. Compressors/Type	1 / 1 / Scroll	1 / 1 / Scroll	1 / 1 / Scroll	1 / 1 / Scroll
Puron Advance™ R-454B Charge A/B (lb-oz)	4-5	—	8-13	—
Humidi-MiZer® Puron Advance R-454B Charge A/B (lb-oz)	—	6-11	—	12-14
Oil A/B (oz)	25	25	42	42
Metering Device	Acutrol	Acutrol	Acutrol	Acutrol
Humidi-MiZer Metering Device	—	TXV-Acutrol	—	TXV-Acutrol
High-Pressure Trip/Reset (psig)	630/505	630/505	630/505	630/505
Low-Pressure Trip/Reset (psig)	54/117	27/44	54/117	27/44
EVAPORATOR COIL				
Material (Tube/Fin)	Cu/Al	Cu/Al	Cu/Al	Cu/Al
Coil Type	3/8 in. RTPF	3/8 in. RTPF	3/8 in. RTPF	3/8 in. RTPF
Rows/FPI	2/15	2/15	3/15	3/15
Total Face Area (ft²)	5.5	5.5	5.5	5.5
Condensate Drain Connection Size	3/4 in.	3/4 in.	3/4 in.	3/4 in.
CONDENSER COIL				
Material	Cu/Al	Cu/Al	Cu/Al	Cu/Al
Coil Type	5/16 in. RTPF	5/16 in. RTPF	5/16 in. RTPF	5/16 in. RTPF
Rows/FPI	1/18	1/18	2/18	2/18
Total Face Area (ft²)	14.6	14.6	15.9	15.9
HUMIDI-MIZER COIL				
Material	—	Cu/Al	—	Cu/Al
Coil Type	—	3/8 in. RTPF	—	3/8 in. RTPF
Rows/FPI	—	1/17	—	2/17
Total Face Area (ft²)	—	4.1	—	4.1
EVAPORATOR FAN AND MOTOR				
Standard/Medium Static 1 Phase				
Motor Qty/Drive Type	1 / Direct	—	1 / Direct	—
Maximum Cont Bhp	0.71	—	1.06	—
Rpm Range	219-2190	—	217-2170	—
Fan Qty/Type	1 / Vane Axial	—	1 / Vane Axial	—
Fan Diameter (in.)	16.6 in.	—	16.6 in.	—
High Static 1 Phase				
Motor Qty/Drive Type	1 / Direct	—	1 / Direct	—
Maximum Cont Bhp	1.07	—	1.53	—
Rpm Range	249-2490	—	246-2460	—
Fan Qty/Type	1 / Vane Axial	—	1 / Vane Axial	—
Fan Diameter (in.)	16.6 in.	—	16.6 in.	—
Standard/Medium Static 3 Phase				
Motor Qty/Drive Type	1 / Direct	1 / Direct	1 / Direct	1 / Direct
Maximum Cont Bhp	0.71	0.71	1.06	1.06
Rpm Range	219-2190	219-2190	217-2170	217-2170
Fan Qty/Type	1 / Vane Axial	1 / Vane Axial	1 / Vane Axial	1 / Vane Axial
Fan Diameter (in.)	16.6 in.	16.6 in.	16.6 in.	16.6 in.
High Static 3 Phase				
Motor Qty/Drive Type	1 / Direct	1 / Direct	1 / Direct	1 / Direct
Maximum Cont Bhp	1.07	1.07	1.96	1.96
Rpm Range	249-2490	249-2490	266-2660	266-2660
Fan Qty/Type	1 / Vane Axial	1 / Vane Axial	1 / Vane Axial	1 / Vane Axial
Fan Diameter (in.)	16.6 in.	16.6 in.	16.6 in.	16.6 in.
CONDENSER FAN AND MOTOR				
Qty / Motor Drive Type	1 / Direct	1 / Direct	1 / Direct	1 / Direct
Motor HP/Rpm	1/4 / 1100	1/4 / 1100	1/4 / 1100	1/4 / 1100
Fan Diameter (in.)	23 in.	23 in.	23 in.	23 in.

48/50FE 3 and 4 Ton Units Physical Data (cont)

48/50FE UNIT	48/50FE*A04	48/50FE*B04	48/50FE*A05	48/50FE*B05
FILTER				
RA Filter Qty / Size (in.)	2 / 16 x 25 x 2	2 / 16 x 25 x 2	2 / 16 x 25 x 2	2 / 16 x 25 x 2
OA Inlet Screen Qty / Size (in.)	1 / 20 x 24 x 1	1 / 20 x 24 x 1	1 / 20 x 24 x 1	1 / 20 x 24 x 1

NOTE(S):

- a. Base unit operating weight does not include weight of options.

LEGEND

- Bhp** — Brake Horsepower
FPI — Fins Per Inch
OA — Outdoor Air
RA — Return Air

48/50FE 5 and 6 Ton Units Physical Data

48/50FE UNIT	48/50FE*A06	48/50FE*B06	48/50FE*M07	48/50FE*N07
NOMINAL TONS	5	5	6	6
BASE UNIT OPERATING WT (lb) 4850FE^a	556/511	556/511	607/562	607/562
REFRIGERATION SYSTEM				
No. Circuits/No. Compressors/Type	1 / 1 / Scroll	1 / 1 / Scroll	1 / 1 / 2-Stage Scroll	1 / 1 / 2-Stage Scroll
Puron Advance™ R-454B Charge A/B (lb-oz)	7-11	—	7-13	—
Humidi-MiZer® Puron Advance R-454B Charge A/B (lb-oz)	—	14	—	18-6
Oil A/B (oz)	42	42	42	42
Metering Device	Acutrol	Acutrol	TXV	TXV
Humidi-MiZer Metering Device	—	TXV-Acutrol	—	TXV
High-Pressure Trip/Reset (psig)	630/505	630/505	630/505	630/505
Low-Pressure Trip/Reset (psig)	54/117	27/44	54/117	27/44
EVAPORATOR COIL				
Material (Tube/Fin)	Cu/Al	Cu/Al	Cu/Al	Cu/Al
Coil Type	3/8 in. RTPF	3/8 in. RTPF	3/8 in. RTPF	3/8 in. RTPF
Rows/FPI	4/15	4/15	4/15	4/15
Total Face Area (ft²)	5.5	5.5	7.3	7.3
Condensate Drain Connection Size	3/4 in.	3/4 in.	3/4 in.	3/4 in.
CONDENSER COIL				
Material	Cu/Al	Cu/Al	Cu/Al	Cu/Al
Coil Type	5/16 in. RTPF	5/16 in. RTPF	5/16 in. RTPF	5/16 in. RTPF
Rows/FPI	2/18	2/18	2/18	2/18
Total Face Area (ft²)	15.9	15.9	15	15
HUMIDI-MIZER COIL				
Material	—	Cu/Al	—	Cu/Al
Coil Type	—	3/8 in. RTPF	—	3/8 in. RTPF
Rows/FPI	—	2/17	—	2/17
Total Face Area (ft²)	—	4.1	—	5.5
EVAPORATOR FAN AND MOTOR				
Standard/Medium Static 1 Phase				
Motor Qty/Drive Type	1 / Direct	—	—	—
Maximum Cont Bhp	1.44	—	—	—
Rpm Range	239-2390	—	—	—
Fan Qty/Type	1 / Vane Axial	—	—	—
Fan Diameter (in.)	16.6 in.	—	—	—
High Static 1 Phase				
Motor Qty/Drive Type	1 / Direct	—	—	—
Maximum Cont Bhp	1.96	—	—	—
Rpm Range	266-2660	—	—	—
Fan Qty/Type	1 / Vane Axial	—	—	—
Fan Diameter (in.)	16.6 in.	—	—	—
Standard/Medium Static 3 Phase				
Motor Qty/Drive Type	1 / Direct	1 / Direct	1 / Direct	1 / Direct
Maximum Cont Bhp	1.44	1.44	1.76	1.76
Rpm Range	239-2390	239-2390	253-2530	253-2530
Fan Qty/Type	1 / Vane Axial	1 / Vane Axial	1 / Vane Axial	1 / Vane Axial
Fan Diameter (in.)	16.6 in.	16.6 in.	16.6 in.	16.6 in.
High Static 3 Phase				
Motor Qty/Drive Type	1 / Direct	1 / Direct	1 / Direct	1 / Direct
Maximum Cont Bhp	2.43	2.43	2.43	2.43
Rpm Range	284-2836	284-2836	284-2836	284-2836
Fan Qty/Type	1 / Vane Axial	1 / Vane Axial	1 / Vane Axial	1 / Vane Axial
Fan Diameter (in.)	16.6 in.	16.6 in.	16.6 in.	16.6 in.
CONDENSER FAN AND MOTOR				
Qty / Motor Drive Type	1 / Direct	1 / Direct	1 / Direct	1 / Direct
Motor HP/Rpm	1/4 / 1100	1/4 / 1100	1/4 / 1100	1/4 / 1100
Fan Diameter (in.)	23 in.	23 in.	23 in.	23 in.

48/50FE 5 and 6 Ton Units Physical Data (cont)

48/50FE UNIT	48/50FE*A06	48/50FE*B06	48/50FE*M07	48/50FE*N07
FILTER				
RA Filter Qty / Size (in.)	2 / 16 x 25 x 2	2 / 16 x 25 x 2	4 / 16 x 16 x 2	4 / 16 x 16 x 2
OA Inlet Screen Qty / Size (in.)	1 / 20 x 24 x 1	1 / 20 x 24 x 1	1 / 20 x 24 x 1	1 / 20 x 24 x 1

NOTE(S):

- a. Base unit operating weight does not include weight of options.

LEGEND

- Bhp** — Brake Horsepower
- FPI** — Fins Per Inch
- OA** — Outdoor Air
- RA** — Return Air

48FE 3 to 5 Ton Gas Heat Data — 1-Phase Units

48FE UNIT	48FE**04	48FE**05	48FE**06
GAS CONNECTION			
No. of Gas Valves	1	1	1
Natural Gas Supply Line Pressure (in. wg)/(psig)	4-13 / 0.18-0.47	4-13 / 0.18-0.47	4-13 / 0.18-0.47
Liquid Propane Supply Line Pressure (in. wg)/(psig)	11-13 / 0.40-0.47	11-13 / 0.40-0.47	11-13 / 0.40-0.47
HEAT ANTICIPATOR SETTING (AMPS)			
First Stage	0.14	0.14	0.14
Second Stage	0.14	0.14	0.14
NATURAL GAS HEAT			
LOW			
No. of Stages / No. of Burners (total)	1 / 2	1 / 2	1 / 2
Connection Size	1/2 in. NPT	1/2 in. NPT	1/2 in. NPT
Rollout Switch Opens / Closes (°F)	195 / 115	195 / 115	195 / 115
Temperature Rise (°F)	25-55	20-55	15-55
MEDIUM			
No. of Stages / No. of Burners (total)	1 / 3	1 / 3	1 / 3
Connection Size	1/2 in. NPT	1/2 in. NPT	1/2 in. NPT
Rollout Switch Opens / Closes (°F)	195 / 115	195 / 115	195 / 115
Temperature Rise (°F)	45-85	30-65	25-65
HIGH			
No. of Stages / No. of Burners (total)	—	1 / 3	1 / 3
Connection Size	—	1/2 in. NPT	1/2 in. NPT
Rollout Switch Opens / Closes (°F)	—	195 / 115	195 / 115
Temperature Rise (°F)	—	45-80	35-80
LIQUID PROPANE HEAT			
LOW			
No. of Stages / No. of Burners (total)	1 / 2	1 / 2	1 / 2
Connection Size	1/2 in. NPT	1/2 in. NPT	1/2 in. NPT
Rollout Switch Opens / Closes (°F)	195 / 115	195 / 115	195 / 115
Temperature Rise (°F)	25-55	20-55	15-55
MEDIUM			
No. of Stages / No. of Burners (total)	1 / 3	1 / 3	1 / 3
Connection Size	1/2 in. NPT	1/2 in. NPT	1/2 in. NPT
Rollout Switch Opens / Closes (°F)	195 / 115	195 / 115	195 / 115
Temperature Rise (°F)	45-85	30-65	25-65
HIGH			
No. of Stages / No. of Burners (total)	—	1 / 3	1 / 3
Connection Size	—	1/2 in. NPT	1/2 in. NPT
Rollout Switch Opens / Closes (°F)	—	195 / 115	195 / 115
Temperature Rise (°F)	—	45-80	35-80

48FE 3 to 6 Ton Gas Heat Data — 3-Phase Units

48FE UNIT	48FE**04	48FE**05	48FE**06	48FE**07
GAS CONNECTION				
No. of Gas Valves	1	1	1	1
Natural Gas Supply Line Pressure (in. wg)/(psig)	4-13 / 0.18-0.47	4-13 / 0.18-0.47	4-13 / 0.18-0.47	4-13 / 0.18-0.47
Liquid Propane Supply Line Pressure (in. wg)/(psig)	11-13 / 0.40-0.47	11-13 / 0.40-0.47	11-13 / 0.40-0.47	11-13 / 0.40-0.47
HEAT ANTICIPATOR SETTING (AMPS)				
First Stage	0.14	0.14	0.14	0.14
Second Stage	0.14	0.14	0.14	0.14
NATURAL GAS HEAT				
LOW				
No. of Stages / No. of Burners (total)	1 / 2	1 / 2	1 / 2	1 / 2
Connection Size	1/2 in. NPT	1/2 in. NPT	1/2 in. NPT	1/2 in. NPT
Rollout Switch Opens / Closes (°F)	195 / 115	195 / 115	195 / 115	195 / 115
Temperature Rise (°F)	25-55	25-55	20-55	15-55
MEDIUM				
No. of Stages / No. of Burners (total)	2 / 3	1 / 3	1 / 3	1 / 3
Connection Size	1/2 in. NPT	1/2 in. NPT	1/2 in. NPT	1/2 in. NPT
Rollout Switch Opens / Closes (°F)	195 / 115	195 / 115	195 / 115	195 / 115
Temperature Rise (°F)	50-85	35-65	30-65	25-65
HIGH				
No. of Stages / No. of Burners (total)	—	2 / 3	2 / 3	2 / 3
Connection Size	—	1/2 in. NPT	1/2 in. NPT	1/2 in. NPT
Rollout Switch Opens / Closes (°F)	—	195 / 115	195 / 115	195 / 115
Temperature Rise (°F)	—	50-80	40-80	35-80
LIQUID PROPANE HEAT				
LOW				
No. of Stages / No. of Burners (total)	1 / 2	1 / 2	1 / 2	1 / 2
Connection Size	1/2 in. NPT	1/2 in. NPT	1/2 in. NPT	1/2 in. NPT
Rollout Switch Opens / Closes (°F)	195 / 115	195 / 115	195 / 115	195 / 115
Temperature Rise (°F)	25-55	25-55	20-55	15-55
MEDIUM				
No. of Stages / No. of Burners (total)	2 / 3	1 / 3	1 / 3	1 / 3
Connection Size	1/2 in. NPT	1/2 in. NPT	1/2 in. NPT	1/2 in. NPT
Rollout Switch Opens / Closes (°F)	195 / 115	195 / 115	195 / 115	195 / 115
Temperature Rise (°F)	50-85	35-65	30-65	25-65
HIGH				
No. of Stages / No. of Burners (total)	—	2 / 3	2 / 3	2 / 3
Connection Size	—	1/2 in. NPT	1/2 in. NPT	1/2 in. NPT
Rollout Switch Opens / Closes (°F)	—	195 / 115	195 / 115	195 / 115
Temperature Rise (°F)	—	50-80	40-80	35-80

48FE 3 to 5 Ton Ultra Low NOx Gas Heat Data — 1 and 3-Phase Units

48FE ULTRA LOW NOx UNIT	48FE**04 ULTRA LOW NOx UNIT	48FE**05 ULTRA LOW NOx UNIT	48FE**06 ULTRA LOW NOx UNIT
GAS CONNECTION			
No. of Gas Valves	1	1	1
Natural Gas Supply Line Pressure (in. wg)/(psig)	5-13 / 0.18-0.47	5-13 / 0.18-0.47	5-13 / 0.18-0.47
HEAT ANTICIPATOR SETTING (AMPS)	0.14	0.14	0.14
NATURAL GAS HEAT			
LOW			
No. of Stages / No. of Burners (total)	1 / 1	1 / 1	1 / 1
Connection Size	1/2 in. NPT	1/2 in. NPT	1/2 in. NPT
Burner Thermal Switch Opens / Closes (°F)	350 / 301	350 / 301	350 / 301
Temperature Rise (°F)	20-50	20-50	15-45
MEDIUM			
No. of Stages / No. of Burners (total)	1 / 1	1 / 1	1 / 1
Connection Size	1/2 in. NPT	1/2 in. NPT	1/2 in. NPT
Burner Thermal Switch Opens / Closes (°F)	350 / 301	350 / 301	350 / 301
Temperature Rise (°F)	20-60	20-60	20-60

Options and accessories



ITEM	FACTORY-INSTALLED OPTION	FIELD-INSTALLED ACCESSORY
GAS HEAT (48FE units only)		
Low, Medium or High Gas Heat — Aluminized Heat Exchanger ^a	X	
Low, Medium or High Gas Heat — Stainless Steel Heat Exchanger	X	
Propane Conversion Kit (48FE only) ^a		X
High Altitude Conversion Kit (48FE only) ^b		X
Flue Discharge Deflector (48FE only)		X
Flue Shield ^a		X
ELECTRIC HEAT (50FE units only)		
Electric Resistance Heaters		X
Single Point Kits		X
CABINET		
Thru-the-Base Electrical or Gas-Line Connections	X	X
Hinged Access Panels	X	
MERV-8 Filters		X
MERV-13 Filters, 2 in.		X
MERV-13 Filters, 4 in.	X	
COIL OPTIONS		
Cu/Cu Indoor and/or Outdoor Coils ^{c,d}	X	
Pre-coated Outdoor Coils ^c	X	
Premium, E-coated Indoor/Outdoor Coils ^c	X	
HUMIDITY CONTROL		
Humidi-MiZer [®] Adaptive Dehumidification System ^c	X	
CONDENSER PROTECTION		
Condenser Coil Hail Guard (louvered design) ^c	X	X
CONTROLS		
Thermostats, Temperature Sensors, and Subbases		X
SystemVu™ DDC Communicating Controller ^e	X	
Smoke Detector (supply and/or return air)	X	X
Horn Strobe Annunciator ^f		X
Time Guard II Compressor Delay Control Circuit		X
Phase Monitor	X	X
Condensate Overflow Switch	X	X
ECONOMIZERS AND OUTDOOR AIR DAMPERS		
EconomizerONE for Electromechanical Controls, complies with FDD (Standard and Ultra Low Leak damper models) ^{c,g}	X	X
Wi-Fi Stick for EconomizerONE (optional)		X
EconoMi\$er [®] 2 for DDC controls (Standard and Ultra Low Leak air damper models) ^{c,e}	X	X
Motorized Two-Position Outdoor-Air Damper		X
Manual Outdoor-Air Damper (25% and 50%)		X
Barometric Relief ^h	X	X
Power Exhaust — Prop Design		X

ITEM	FACTORY-INSTALLED OPTION	FIELD-INSTALLED ACCESSORY
ECONOMIZER SENSORS AND IAQ DEVICES		
Single Dry Bulb Temperature Sensors ⁱ	X	X
Differential Dry Bulb Temperature Sensors ⁱ		X
Single Enthalpy Sensors ⁱ	X	X
Differential Enthalpy Sensors ⁱ		X
CO ₂ Sensor (wall, duct, or unit mounted) ^j	X	X
INDOOR MOTOR AND DRIVE		
Multiple Motor and Drive Packages	X	
Fan Filter Status Switch	X	X
LOW AMBIENT CONTROL		
Winter Start Kit ^k		X
Low Ambient Controller to -20°F (-29°C) ^l		X
POWER OPTIONS		
Convenience Outlet (powered) ^c	X	
Convenience Outlet (unpowered)	X	X
Non-Fused Disconnect ^{l,m}	X	
High SCCR Protection ⁿ	X	
ROOF CURBS		
Roof Curb 14 in. (356 mm)		X
Roof Curb 24 in. (610 mm)		X

NOTE(S):

- Not available for 48FE Ultra Low NOx units.
- Not necessary for 48FE Ultra Low NOx units.
- Not available as a factory-installed option on single phase (-3 voltage code) models. Use field-installed accessory where available.
- Cu/Cu coils are only available with louvered hail guards.
- Models with SystemVu controls comply with California Title 24 Fault Detection and Diagnostic (FDD).
- Requires a field-supplied 24-v transformer for each application. See price pages for details.
- FDD (Fault Detection and Diagnostic) capability per California Title 24 section 120.2.
- Included with economizer.
- Sensors used to optimize economizer performance.
- See application data for assistance.
- Not necessary on SystemVu units, as they are capable of operating at temperatures down to 25°F (4°C).
- Non-fused disconnect switch cannot be used when unit electrical rating exceeds:
208/230-1-60 and 208/230-3-60 = 80 amps (FLA).
480-3-60 and 575-3-60 = 80 amps (FLA).
Carrier RTUBuilder automatically selects the amp limitations.
- Not available for 48FE Ultra Low NOx 460-v units.
- High SCCR (Short Circuit Current Rating) is not available on the following: units with Humidi-MiZer system, low ambient controls, phase loss monitor, non-fused disconnect, powered convenience outlet, or 575-v models.

Factory-installed options

Economizer (dry-bulb or enthalpy)

Economizers save money. They bring in fresh, outside air for ventilation and provide outside air to cool your building. This is the preferred method of low-ambient cooling. When used with CO₂ sensors, economizers can provide even more savings by adjusting the ventilation air intake to just the correct amount.

Economizers are available, installed and tested by the factory, with either enthalpy or dry-bulb temperature inputs. Additional sensors are available as accessories to optimize the economizers.

Economizers include a powered exhaust system and gravity-controlled barometric relief to help equalize building pressures. Gravity-controlled barometric relief also helps equalize ambient air pressures. This can be a cost effective solution to prevent building pressurization. Economizers are available in ultra low leak and standard low leak versions. They can be factory-installed or easily field installed.

Unit-mounted CO₂ sensor

The CO₂ sensor works with the economizer to intake only the correct amount of outside air for ventilation. As occupants fill your building, the CO₂ sensor detects their presence through increasing CO₂ levels and opens the economizer appropriately. When the occupants leave, the CO₂ levels decrease, and the sensor appropriately closes the economizer. This intelligent control of the ventilation air, called demand controlled ventilation (DCV), reduces the overall load on the rooftop, saving money. It is also available as a field-installed accessory.

Smoke detector (supply and/or return air)

Our smoke detectors make your application safer and your job easier. Carrier smoke detectors immediately shut down the rooftop unit when smoke is detected. They are available, installed by the factory, for supply air, return air, or both.

Optional Humidi-MiZer[®] adaptive dehumidification system

Carrier's Humidi-MiZer adaptive dehumidification system is an all-inclusive factory-installed option that can be ordered with any WeatherMaker[®] 48/50FE 04-07 rooftop unit, with the exception of single phase voltage (208/230-1-60) units.

This system expands the envelope of operation of Carrier's WeatherMaker rooftop units to provide unprecedented flexibility to meet year-round comfort conditions.

The Humidi-MiZer adaptive dehumidification system has a unique dual operational mode setting. It provides greater dehumidification of the occupied space through 2 modes of dehumidification operations, in addition to its normal design cooling mode.

When coupled with the Humidi-MiZer system, the 48/50FE 04-07 rooftop is capable of operating in normal design cooling mode, sub-cooling mode, and hot gas reheat mode. Normal design cooling mode is when the unit operates under its normal sequence of operation by cycling compressors to maintain comfort conditions.

Sub-cooling mode operates to satisfy part load type conditions when the space requires combined sensible and a higher proportion of latent load control. Hot gas reheat mode operates when outdoor temperatures fall and latent capacity is required for humidity control. Hot gas reheat mode provides neutral air for maximum dehumidification operation.

NOTE: Humidi-MiZer system includes Low Ambient controller.

Thru-the-base connections

Thru-the-base connections, available as a factory option, are necessary to ensure proper connection and seal when routing wire and piping through the rooftop's basepan and curb. These couplings eliminate roof penetration and should be considered for gas lines, main power lines, and control power.

Hinged access panels

These specially designed hinged access panels allow access to the unit's major components. Panels allow access to filters, the control box, and the indoor fan motor.

MERV-13 return air filters

This factory option upgrades the return air filters from standard unit filters to high efficiency 4 in. MERV-13 filters. Uses non-woven MERV-13 filter media with a high strength, moisture-resistant frame. Filter media is securely fastened inside the filter frame on all 4 sides.

Cu/Cu (indoor and outdoor) coils

Copper fins and copper tubes are mechanically bonded to copper tubes and copper tube sheets. A polymer strip prevents the coil assembly from contacting the sheet metal coil pan to minimize the potential for galvanic corrosion between coil and pan. Only available with louvered hail guards.

E-coated (outdoor and indoor) coils

These coils feature a flexible epoxy polymer coating uniformly applied to all coil surface areas without material bridging between fins. The coating process ensures complete coil encapsulation of tubes, fins, and headers.

Pre-coated outdoor coils

These coils feature a durable epoxy-phenolic coating that provides protection in mildly corrosive coastal environments. The coating minimizes galvanic action between dissimilar metals. The coating is applied to the aluminum fin stock prior to the fin stamping process to create an inert barrier between the aluminum fin and copper tube.

Condenser coil hail guard

These sleek, louvered panels protect the condenser coil from hail damage, foreign objects, and incidental contact. This can be purchased as a factory-installed option or as a field-installed accessory.

Single enthalpy sensor

This sensor allows the economizer to account for both the humidity and temperature of outside air conditions, providing additional comfort.

Stainless steel heat exchanger (48FE units only)

For this option, the tubular heat exchanger is made out of a minimum 20 gauge type 409 stainless steel for applications where the mixed air going to the heat exchanger is expected to drop below 45°F (7°C). Stainless steel may be specified on applications where the presence of airborne contaminants require its use (applications such as paper mills) or in areas with very high outdoor humidity that may result in severe condensation in the heat exchanger during cooling operation.

Convenience outlet (powered or unpowered)

Reduce service and/or installation costs by including a convenience outlet in your specification. Carrier will install this service feature at our factory. It provides a convenient, 15 amp, 115-v GFCI receptacle with “Wet in Use” cover. The “powered” option allows the installer to power the outlet from the line side of the disconnect or load side as required by code.

The “unpowered” option is to be powered from a separate 115/120-v power source. This outlet is available as a 15 amp factory-installed option or a 20 amp field-installed accessory.

Non-fused disconnect

This OSHA-compliant, factory-installed safety switch allows a service technician to locally secure power to the rooftop. When selecting a factory-installed non-fused disconnect, note that they are sized for the unit as ordered from the factory. The sizing does not accommodate field-installed items such as power exhaust devices, etc. If field installing electric heat with factory-installed non-fused disconnect switch, a single point kit may or may not be required.

NOTE: Not available for 48FE Ultra Low NOx 460-v units.

SystemVu™ controller

Carrier’s SystemVu controller is an optional factory-installed and tested controller.

This option provides a whole new approach by using an intuitive, intelligent controller that not only monitors and controls the unit but also provides linkage to multiple building automation systems.

Each SystemVu controller makes it easy to set up, service, troubleshoot, access historical data, generate reports, and provide comfort only Carrier is noted for.

Key features include:

- Easy-to-read backlit 4-line text screen for superior visibility
- Quick operational condition LEDs for Run, Alert, and Fault
- Simple navigation using large keypad buttons for Navigation arrows, Test, Back, Enter, and Menu
- Capable of being controlled with a conventional thermostat, space sensor, or building automation system
- Service capabilities include:
 - Auto run test
 - Manual run test
 - Component run hours and starts
 - Commissioning reports
 - Data logging

- Full range of diagnosis:
 - Read refrigerant pressures without needing gauges
 - Sensor faults
 - Compressor reverse rotation
 - Economizer diagnostics that meet California Title 24 requirements
- Quick data transfer via USB port:
 - Unit configuration uploading/downloading
 - Data logging
 - Software upgrades
- Built in capacity for:
 - i-Vu® open systems
 - BACnet® systems
 - CCN systems
- Configuration and alarm point capability:
 - Contain over 100 alarm codes
 - Contain over 260 status, troubleshooting, diagnostic, and maintenance points
 - Contain over 270 control configuration setpoints

Condensate overflow switch

This sensor and related controller monitor the condensate level in the drain pan and shut down compression operation when overflow conditions occur. This option:

- Includes an indicator light showing when the sensor is disconnected (blinking red) and when there has been more than 10 seconds of water contact (solid red — compressors disabled)
- Includes a 10-second delay to break, which eliminates nuisance trips from splashing or waves in the pan (sensor needs 10 seconds of constant water contact before tripping)
- Disables the compressor(s) operation when a condensate plug is detected but still allows fans to run for the economizer

Fan filter status switch and maintenance indicator

When the optional factory-installed filter maintenance indicator is used, a factory-installed differential pressure switch measures pressure drop across the outside air filter and activates a field-supplied dry contact indicator when the pressure differential exceeds the adjustable switch setpoint.

High Short Circuit Current Rating (SCCR) protection

This factory-installed option provides high short circuit current protection of 10 kA against high potential fault current situations for the compressor and all indoor and outdoor fan motors. (A standard unit comes with 5 kA rating.)

This option is not available on 575 volt models or models with a factory-installed non-fused disconnect, Humidi-MiZer system, phase loss monitor/protection, powered convenience outlet, or low ambient controls.

Field-installed accessories

Condenser coil hail guard

These sleek, louvered panels protect the condenser coil from hail damage, foreign objects, and incidental contact. This can be purchased as a factory-installed option or as a field-installed accessory.

Differential enthalpy sensor

The differential enthalpy sensor is comprised of an outdoor and a return air enthalpy sensor to provide differential enthalpy control. The sensor allows the unit to determine whether outside air is suitable for free cooling.

Wall or duct-mounted CO₂ sensor

The IAQ sensor shall be available for duct or wall mount. The sensor provides demand ventilation indoor air quality (IAQ) control.

Propane conversion kit (48FE units only)

Convert your gas heat rooftop from standard natural gas operation to propane using this field-installed kit.

NOTE: Not available for 48FE Ultra Low NO_x units.

High altitude conversion kit (48FE units only)

High altitudes have less oxygen, which affects the fuel/air mixture in heat exchangers. In order to maintain a proper fuel/air mixture, heat exchangers operating in altitudes above 2000 ft (610 m) require different orifices. To select the correct burner orifices or determine the heat capacity for a high altitude application, use either the selection software or the unit's service manual. High altitudes have less oxygen, which means heat exchangers need less fuel. The new gas orifices in this field-installed kit make the necessary adjustment for high altitude applications. They restore the optimal fuel to air mixture and maintain healthy combustion at altitudes above 2000 ft (610 m).

NOTE: Typical natural gas heating value ranges from 975 to 1050 Btu/ft³ at sea level nationally. The heating value goes down approximately 1.7% per every thousand feet of elevation. Standard factory orifices can typically be used up to 2000 ft (610 m) elevations without any operational issues.

NOTE: High altitude conversion kit is not necessary for 48FE Ultra Low NO_x units. These units are factory-configured to operate up to 7,800 feet (2377 m). Use at altitudes above 7,800 feet (2377 m) is not permitted under any circumstances.

Flue discharge deflector (48FE units only)

The flue discharge deflector is a useful accessory when flue gas recirculation is a concern. By venting the flue discharge upwards, the deflector minimizes the chance for a neighboring unit to intake the flue exhaust.

MERV-8 and MERV-13 return air filters

These field-installed accessories provide a return air filter upgrade from standard unit filters to high efficiency MERV-8 or 2 in. MERV-13 filters. Uses non-woven filter media with high strength, moisture-resistant frame. Filter media is securely fastened inside the filter frame on all 4 sides.

Phase monitor protection

The phase monitor control monitors the sequence of the 3-phase electrical system to provide phase reversal protection and monitors the 3-phase voltage inputs to provide phase loss protection for the 3-phase device. It will work on either a Delta or Wye power connection.

Winter start kit

Carrier's winter start kit extends the low ambient limit of your rooftop to 25°F (-4°C). The kit bypasses the low pressure switch, preventing nuisance tripping of the switch. Other low ambient precautions may still be prudent.

Low ambient controller

The low ambient controller is a head pressure controller kit designed to maintain the unit's condenser head pressure during periods of low ambient cooling operation. This device should be used as an alternative to economizer free cooling when economizer usage is either not appropriate or not desired. The low ambient controller will either cycle the outdoor fan motors or operate them at reduced speed to maintain the unit operation, depending on the model. This controller allows cooling operation down to -20°F (-29°C) ambient conditions.

Roof curb (14 in./356 mm or 24 in./610 mm)

This full perimeter roof curb with exhaust capability provides separate air streams for energy recovery from the exhaust air without supply air contamination.

Fan filter status switch and maintenance indicator

When a field-installed filter maintenance indicator is used, a field-installed differential pressure switch measures pressure drop across the outside air filter and activates a field-supplied dry contact indicator when the pressure differential exceeds the adjustable switch setpoint.

Power exhaust

This accessory provides superior internal building pressure control and may eliminate the need for costly external pressure control fans.

Manual OA damper

Manual outdoor air dampers are an economical way to bring in ventilation air. The dampers are available in 25% and 50% versions.

NOTE: See application tip "ROOFTOP-18-01" prior to use of this damper on 07 size models.

Motorized two-position damper

The Carrier two-position, motorized outdoor air damper admits up to 100% outside air. Using reliable, gear-driven technology, the two-position damper opens to allow ventilation air and closes when the rooftop stops, stopping unwanted infiltration.

NOTE: See application tip "ROOFTOP-18-01" prior to use of this damper on 07 size models.

Electric heaters (50FE units only)

Carrier offers a full-line of field-installed accessory heaters. The heaters are very easy to use and install, and they are all pre-engineered and certified.

Time Guard II control circuit

This accessory protects your compressor by preventing short-cycling in the event of some other failure by preventing the compressor from restarting for 30 seconds after stopping. (Not required with SystemVu™ controller or authorized commercial thermostats.)

Options and accessories (cont)



Wi-Fi Stick for EconomizerONE (optional)

The accessory Wi-Fi/WLAN stick can be connected to the EconomizerONE POL224 economizer controller via the USB host interface. The Wi-Fi stick enables a wireless connection to be made between a smartphone and the economizer controller via the Climatix™¹ mobile application for commissioning, troubleshooting, and maintenance operations. The Wi-Fi stick is required to utilize the mobile application.

1. Third-party trademarks and logos are the property of their respective owners.

Climatix™ mobile application

The Climatix™ mobile application offers a best-in-class user interface and a simple step-by-step commissioning workflow using a mobile device. The user interface walks users through the setup of the controller and allows users to view the operating mode and parameters. Users can adjust set-points, initiate damper tests, and save the final configuration as a favorite to expedite setup in the future.

The application is available on Android™¹ and Apple iOS®¹ platforms. The Wi-Fi stick for the EconomizerONE is required to join the Siemens-WiFi-Stick network and setup the controller on a smartphone.

Options and Accessory Weights

OPTION / ACCESSORY NAME	48/50FE UNIT WEIGHT ^a							
	04		05		06		07	
	lb	kg	lb	kg	lb	kg	lb	kg
Humidi-MiZer® System ^b	15	7	15	7	15	7	24	11
Power Exhaust — Vertical or Horizontal	45	21	45	21	45	21	45	21
EconomizerONE or EconoMiSer® 2	51	23	51	23	51	23	51	23
Two-Position Damper	39	18	39	18	39	18	58	26
Manual Damper	12	5	12	5	12	5	18	8
Medium Gas Heat (48FE units only) ^c	9	4	9	4	9	4	15	7
High Gas Heat (48FE units only) ^c	—	—	63	29	63	29	63	29
Hail Guard (louvered)	13	6	13	6	13	6	17	8
Cu/Cu Condenser Coil	37	17	74	34	74	34	95	43
Cu/Cu Evaporator Coil	38	17	38	17	38	17	70	32
Roof Curb (14 in. curb)	95	43	95	43	95	43	95	43
Roof Curb (24 in. curb)	150	68	150	68	150	68	150	68
CO ₂ Sensor	2	1	2	1	2	1	2	1
Flue Discharge Deflector	7	3	7	3	7	3	7	3
Optional Indoor Motor/Drive	10	5	10	5	10	5	15	7
Low Ambient Controller	9	4	9	4	9	4	9	4
Winter Start Kit	5	2	5	2	5	2	5	2
Return Air Smoke Detector	7	3	7	3	7	3	7	3
Supply Air Smoke Detector	7	3	7	3	7	3	7	3
Fan Filter Switch	2	1	2	1	2	1	2	1
Non-Fused Disconnect	15	7	15	7	15	7	15	7
Powered Convenience Outlet ^d	36	16	36	16	36	16	36	16
Unpowered Convenience Outlet	4	2	4	2	4	2	4	2
Enthalpy Sensor	2	1	2	1	2	1	2	1
Differential Enthalpy Sensor	3	1	3	1	3	1	3	1

NOTE(S):

- Where multiple variations are available, the heaviest combination is listed.
- For Humidi-MiZer system, add low ambient controller weight.
- Values do not apply for 48FE Ultra Low NOx units.
- Weight includes convenience outlet and convenience outlet transformer.

48FE**04-07 Base Unit Dimensions

NOTES:

1. DIMENSIONS ARE IN INCHES. DIMENSIONS IN [] ARE IN MILLIMETERS.
2. CENTER OF GRAVITY
3. DIRECTION OF AIR FLOW
4. ALL VIEW DRAWN USING 3RD ANGLE

UNIT	J	K
48FE**04	33 3/8 [847]	18 5/8 [472]
48FE**05	33 3/8 [847]	14 7/8 [377]
48FE**06	33 3/8 [847]	14 7/8 [377]
48FE**07	41 3/8 [1051]	18 5/8 [472]

Carrier THIS DOCUMENT IS THE PROPERTY OF CARRIER CORPORATION AND IS DELIVERED UPON THE EXPRESS CONDITION THAT THE CONTENTS WILL NOT BE DISCLOSED OR USED WITHOUT CARRIER CORPORATION'S WRITTEN CONSENT. SUBMISSION OF THESE DRAWINGS OR DOCUMENTS DOES NOT CONSTITUTE PART PERFORMANCE OR ACCEPTANCE OF CONTRACT.

CONNECTION SIZES	
A	1 3/8" [35] DIA FIELD POWER SUPPLY HOLE
B	2" [50] DIA POWER SUPPLY KNOCKOUT
C	1 3/4" [51] DIA GAUGE ACCESS PLUG
D	7/8" [22] DIA FIELD CONTROL WIRING HOLE
E	3/4"-14 NPT CONDENSATE DRAIN
F	1/2"-14 NPT GAS CONNECTION
G	2 1/2" [64] DIA POWER SUPPLY KNOCK-OUT

THRU-THE-BASE CHART THESE HOLES REQUIRED FOR USE CRBTPWRO08A00, 009A00			
	THREADED CONDUIT SIZE	WIRE USE	REQ'D HOLE SIZES (MAX.)
W	1/2"	115V	7/8" [22.2]
X	1/2"	24V	7/8" [22.2]
Y	3/4"	POWER	1-1/8" [28.6]
Z*	(009A00) 1/2" FPT	GAS	1-1/8" [28.6]
FOR "THRU-THE-BASEPAN" FACTORY OPTION, FITTINGS FOR ONLY X, Y, & Z ARE PROVIDED			
* (008A00) PROVIDES 3/4" FPT THRU CURB FLANGE & FITTING.			

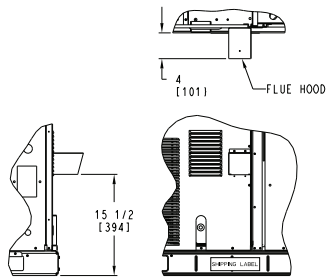

DETAIL U
FLUE HOOD OPENING FOR
ULTRA LOW NOX UNITS ONLY
SCALE 1:8

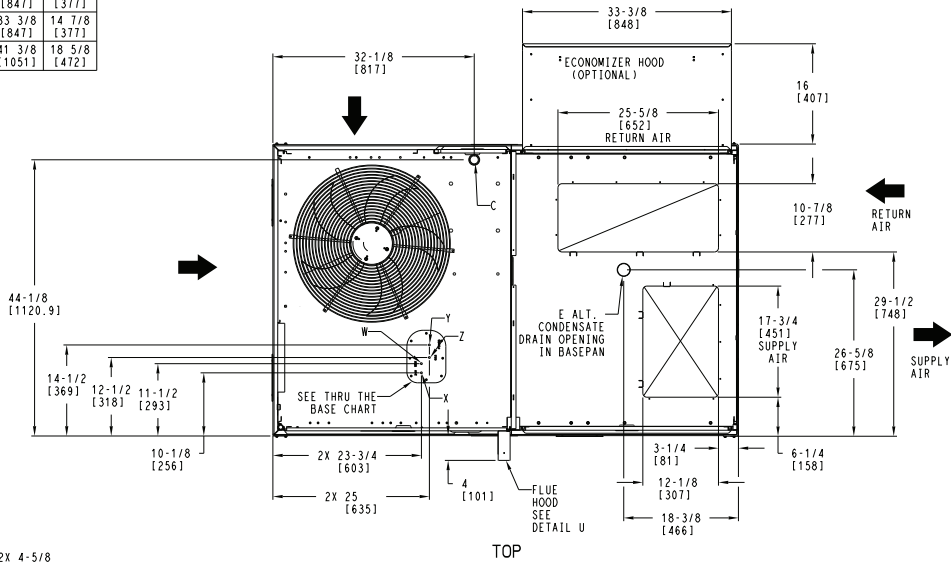

TOP

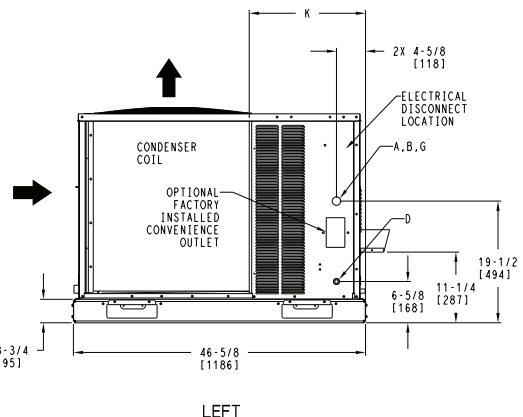

LEFT

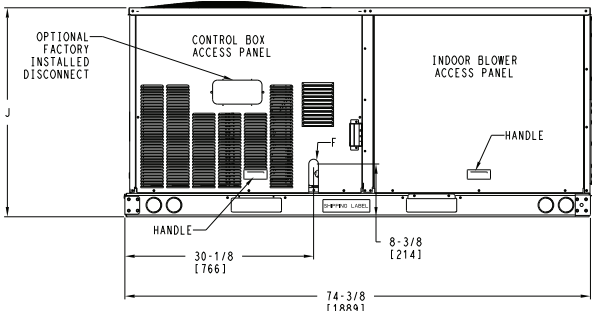

FRONT

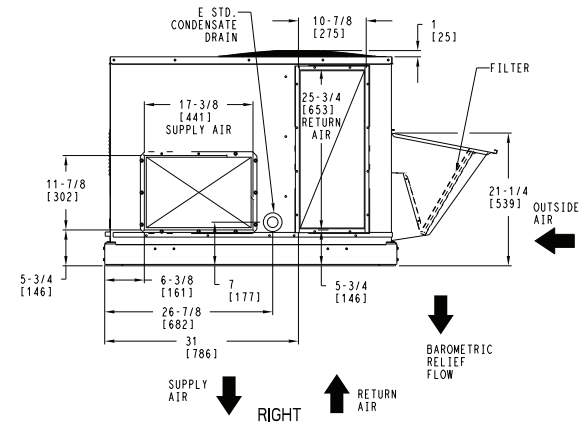

RIGHT

ITC CLASSIFICATION	SHEET	DATE	SUPERCEDES	48FE 04-07 SINGLE PACKAGE ELECTRICAL COOLING WITH GAS HEAT	48TC006964	REV
U.S. ECCN:NSR	1 OF 3	11/17/23	-			-



48FE**04-07 Base Unit Dimensions (cont)

Carrier THIS DOCUMENT IS THE PROPERTY OF CARRIER CORPORATION AND IS DELIVERED UPON THE EXPRESS CONDITION THAT THE CONTENTS WILL NOT BE DISCLOSED OR USED WITHOUT CARRIER CORPORATION'S WRITTEN CONSENT. SUBMISSION OF THESE DRAWINGS OR DOCUMENTS DOES NOT CONSTITUTE PART PERFORMANCE OR ACCEPTANCE OF CONTRACT.

UNIT	STD. UNIT WEIGHT **		CORNER WEIGHT (A)		CORNER WEIGHT (B)		CORNER WEIGHT (C)		CORNER WEIGHT (D)		C.G.			HEIGHT
	LBS.	KG.	LBS.	KG.	LBS.	KG.	LBS.	KG.	LBS.	KG.	X	Y	Z	
48FE**04	482	219	113	51	116	53	128	58	125	57	37 5/8 [956]	24 9/16 [624]	18 1/4 [464]	
48FE**05	543	246	138	63	133	60	133	60	138	63	36 1/2 [927]	23 3/8 [594]	18 [457]	
48FE**06	556	252	142	64	136	62	136	62	142	64	36 1/2 [927]	23 3/8 [594]	18 [457]	
48FE**07	607	275	162	73	152	69	141	64	151	68	36 [914]	22 1/2 [572]	19 3/8 [492]	

** STANDARD UNIT WEIGHT IS WITH LOW GAS HEAT AND WITHOUT PACKAGING. FOR OTHER OPTIONS AND ACCESSORIES, REFER TO THE PRODUCT DATA CATALOG.

THIS TABLE IS FOR "ULTRA LOW NOX" UNITS ONLY

UNIT	STD. UNIT WEIGHT **		CORNER WEIGHT (A)		CORNER WEIGHT (B)		CORNER WEIGHT (C)		CORNER WEIGHT (D)		C.G.			HEIGHT
	LBS.	KG.	LBS.	KG.	LBS.	KG.	LBS.	KG.	LBS.	KG.	X	Y	Z	
48FIG*04	512	233	120	55	122	55	136	62	134	61	37 1/2 [953]	24 11/16 [627]	18 1/8 [460]	
48FIG*05	573	260	146	66	139	63	141	64	147	67	36 3/8 [924]	23 1/2 [597]	18 [457]	
48FIG*06	586	266	149	68	143	65	144	65	151	69	36 3/8 [924]	23 1/2 [597]	18 [457]	

** STANDARD UNIT WEIGHT IS WITH WITHOUT PACKAGING. FOR OTHER OPTIONS AND ACCESSORIES, REFER TO THE PRODUCT DATA CATALOG.

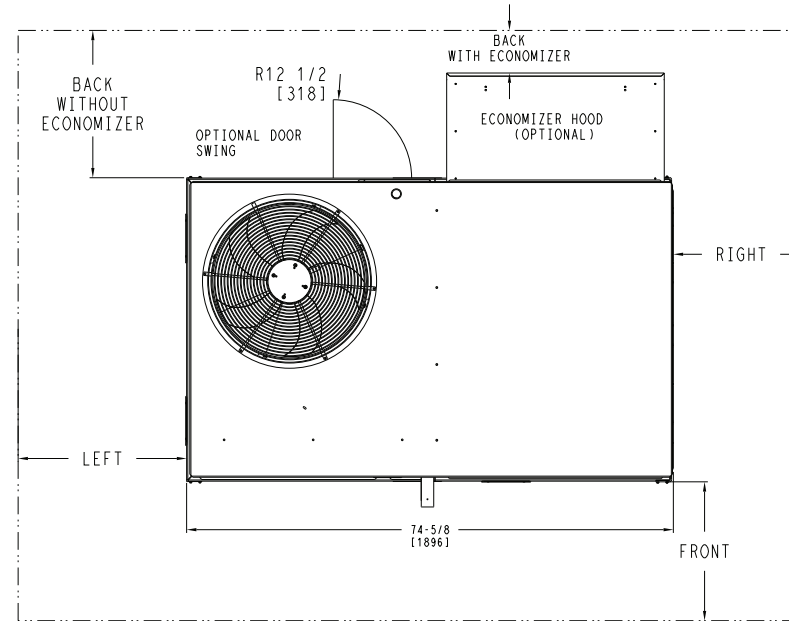
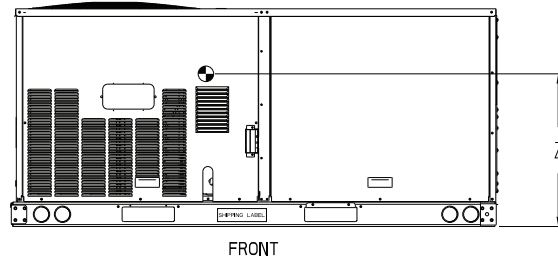
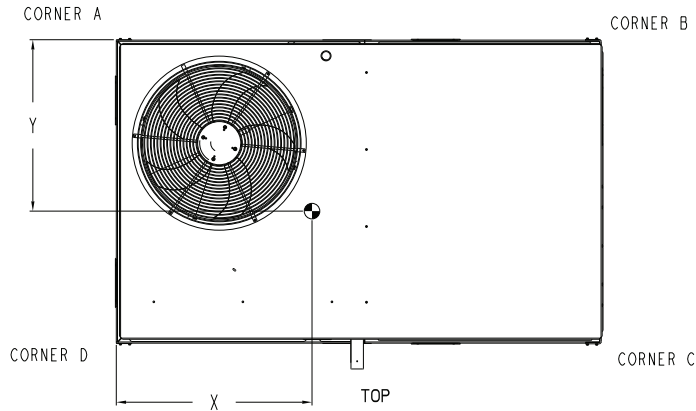

NOTES:

1. FOR ALL MINIMUM CLEARANCES LOCAL CODES OR JURISDICTIONS MAY PREVAIL.

SURFACE	CLEARANCE		OPERATING CLEARANCE
	SERVICE WITH: CONDUCTIVE BARRIER	SERVICE WITH: NONCONDUCTIVE BARRIER	
FRONT	48 [1219mm]	36 [914mm]	18 [457mm]
LEFT	48 [1219mm]	42 [1067mm]	18 [457mm]
BACK W/O HOOD	48 [1219mm]	42 [1067mm]	18 [457mm]
BACK W/HOOD	36 [914mm]	36 [914mm]	18 [457mm]
RIGHT	36 [914mm]	36 [914mm]	18 [457mm]
TOP	72 [1829mm]	72 [1829mm]	72 [1829mm]

ITC CLASSIFICATION	SHEET	DATE	SUPERCEDES	48FE 04-07 SINGLE PACKAGE ELECTRICAL COOLING WITH GAS HEAT	48TC006964	REV
U.S. ECCN:NSR	2 OF 3	11/17/23	-			-



48FE**04-07 Base Unit Dimensions (cont)

Carrier THIS DOCUMENT IS THE PROPERTY OF CARRIER CORPORATION AND IS DELIVERED UPON THE EXPRESS CONDITION THAT THE CONTENTS WILL NOT BE DISCLOSED OR USED WITHOUT CARRIER CORPORATION'S WRITTEN CONSENT. SUBMISSION OF THESE DRAWINGS OR DOCUMENTS DOES NOT CONSTITUTE PART PERFORMANCE OR ACCEPTANCE OF CONTRACT.

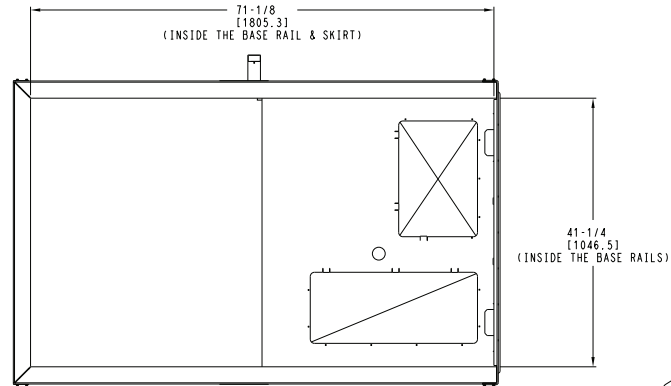
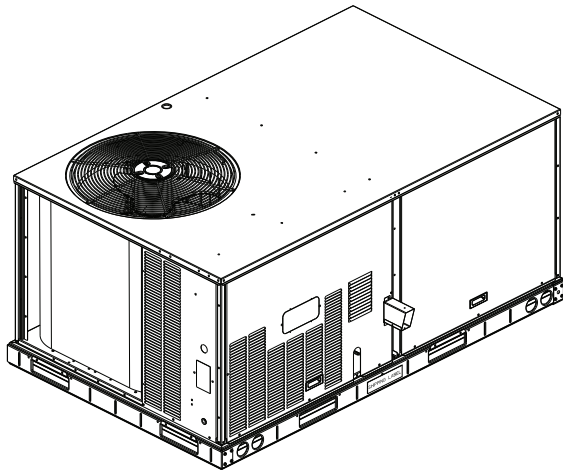

INSIDE BASERAIL DIMENSIONS

BOTTOM

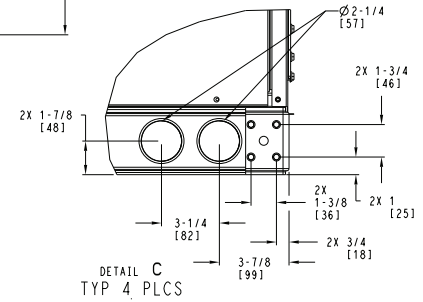

DETAIL C
TYP 4 PLCS

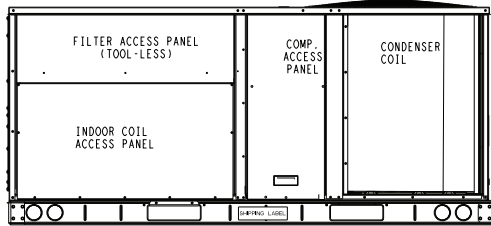

BACK

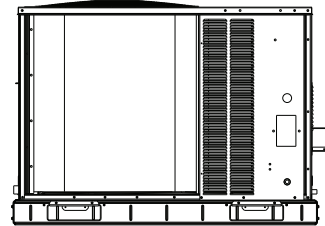

LEFT

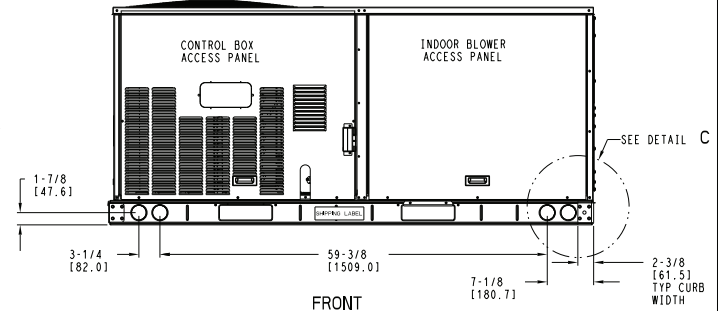

FRONT

ITC CLASSIFICATION	SHEET	DATE	SUPERCEDES	48FE 04-07 SINGLE PACKAGE ELECTRICAL COOLING WITH GAS HEAT	48TC006964	REV
U.S. ECCN:NSR	3 OF 3	11/17/23	-			-



50FE-*04-07 Base Unit Dimensions

- NOTES:
1. DIMENSIONS ARE IN INCHES. DIMENSIONS IN [] ARE IN MILLIMETERS.
 2. CENTER OF GRAVITY
 3. DIRECTION OF AIR FLOW
 4. ALL VIEW DRAWN USING 3RD ANGLE

UNIT	J	K
50FE**04	33 3/8 [847]	18 5/8 [472]
50FE**05	33 3/8 [847]	14 7/8 [377]
50FE**06	33 3/8 [847]	14 7/8 [377]
50FE**07	41 3/8 [1051]	18 5/8 [472]



THIS DOCUMENT IS THE PROPERTY OF CARRIER CORPORATION AND IS DELIVERED UPON THE EXPRESS CONDITION THAT THE CONTENTS WILL NOT BE DISCLOSED OR USED WITHOUT CARRIER CORPORATION'S WRITTEN CONSENT.

SUBMISSION OF THESE DRAWINGS OR DOCUMENTS DOES NOT CONSTITUTE PART PERFORMANCE OR ACCEPTANCE OF CONTRACT.

CONNECTION SIZES		
A	1 3/8" [35]	DIA FIELD POWER SUPPLY HOLE
B	2" [51]	DIA POWER SUPPLY KNOCKOUT
C	1 3/4" [44]	DIA GAUGE ACCESS PLUG
D	7/8" [22]	DIA FIELD CONTROL WIRING HOLE
E	3/4"-14 NPT	CONDENSATE DRAIN
G	2 1/2" [64]	DIA POWER SUPPLY KNOCK-OUT

THRU-THE-BASE CHART THESE HOLES REQUIRED FOR USE CRBTMPWR008A00, 009A00			
	THREADED CONDUIT SIZE	WIRE USE	REQ'D HOLE SIZES (MAX.)
W	1/2"	115V	7/8" [22.2]
X	1/2"	24V	7/8" [22.2]
Y *	3/4"	POWER	1 1/8" [28.6]
Z **	(009A00) 1/2" FPT	GAS	1 1/8" [28.6]

FOR "THRU-THE-BASEPAN" FACTORY OPTION, FITTINGS FOR ONLY X, Y, & Z ARE PROVIDED

* SELECT EITHER 3/4" OR 1/2" FOR POWER, DEPENDING ON WIRE SIZE

** (008A00) PROVIDES 3/4" FPT THRU CURB FLANGE & FITTING.

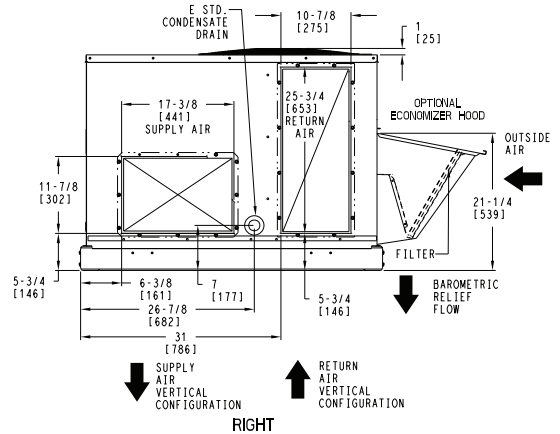
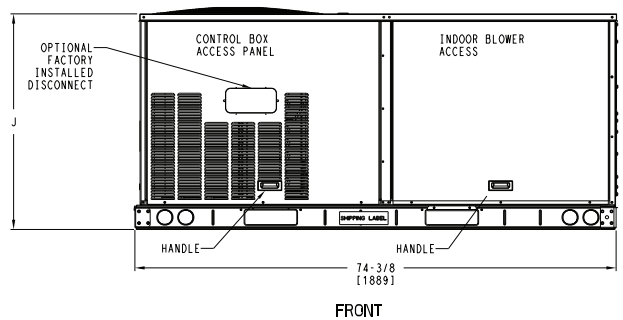
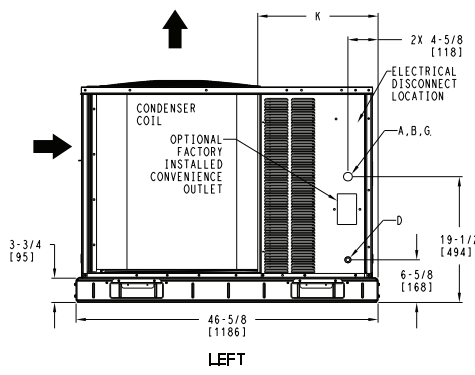
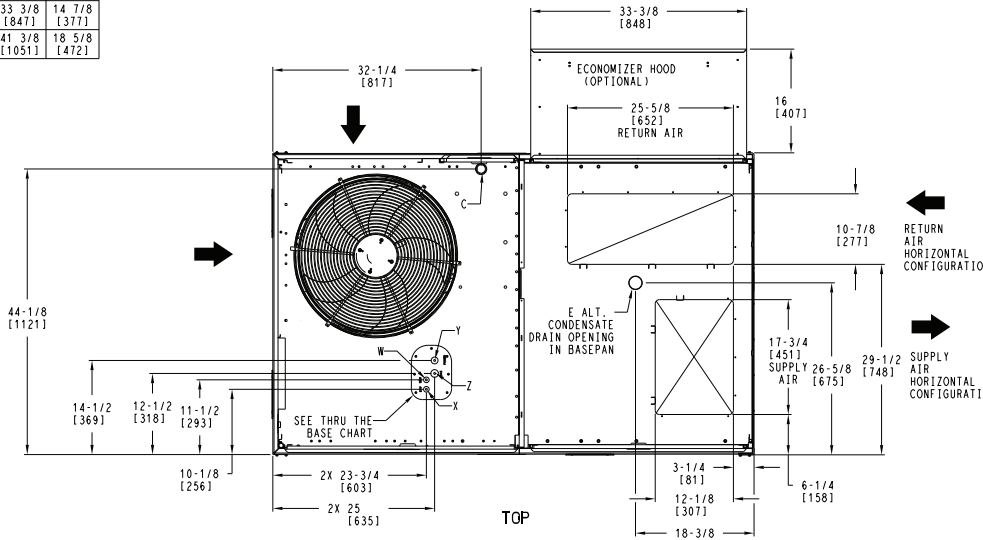

ITC CLASSIFICATION	SHEET	DATE	SUPERCEDES	50FE 04-07 SINGLE PACKAGE ELECTRICAL COOLING WITH ELECTRIC HEAT	48TC006965	REV
U.S. ECCN:NSR	1 OF 3	11/20/23	-			-

Base unit dimensions (cont)



50FE-*04-07 Base Unit Dimensions (cont)

UNIT	STD. UNIT WEIGHT*		CORNER WEIGHT (A)		CORNER WEIGHT (B)		CORNER WEIGHT (C)		CORNER WEIGHT (D)		C.G.			HEIGHT
	LBS.	KG.	LBS.	KG.	LBS.	KG.	LBS.	KG.	LBS.	KG.	X	Y	Z	
50FE**04	437	198	110	50	107	49	108	49	112	51	36 5/8 [930]	23 9/16 [598]	18 1/2 [470]	
50FE**05	498	226	136	62	124	56	114	52	125	57	35 1/2 [902]	22 3/8 [568]	18 1/4 [464]	
50FE**06	511	232	139	63	127	58	117	53	128	58	35 1/2 [902]	22 3/8 [568]	18 1/4 [464]	
50FE**07	562	255	154	70	137	62	127	58	143	65	35 [889]	22 1/2 [572]	19 1/2 [495]	

* STANDARD UNIT WEIGHT IS WITHOUT ELECTRIC HEAT AND WITHOUT PACKAGING. FOR OTHER OPTIONS AND ACCESSORIES, REFER TO THE PRODUCT DATA CATALOG.

Carrier THIS DOCUMENT IS THE PROPERTY OF CARRIER CORPORATION AND IS DELIVERED UPON THE EXPRESS CONDITION THAT THE CONTENTS WILL NOT BE DISCLOSED OR USED WITHOUT CARRIER CORPORATION'S WRITTEN CONSENT. SUBMISSION OF THESE DRAWINGS OR DOCUMENTS DOES NOT CONSTITUTE PART PERFORMANCE OR ACCEPTANCE OF CONTRACT.

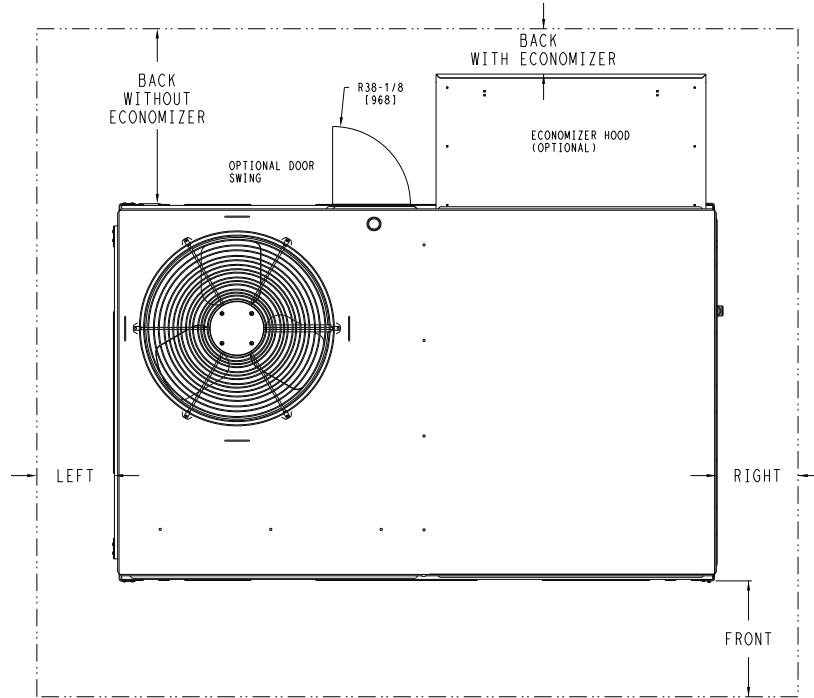
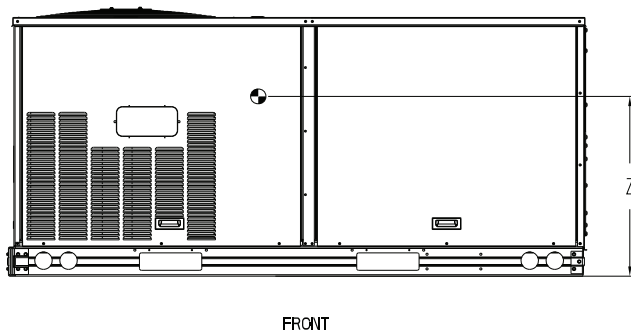
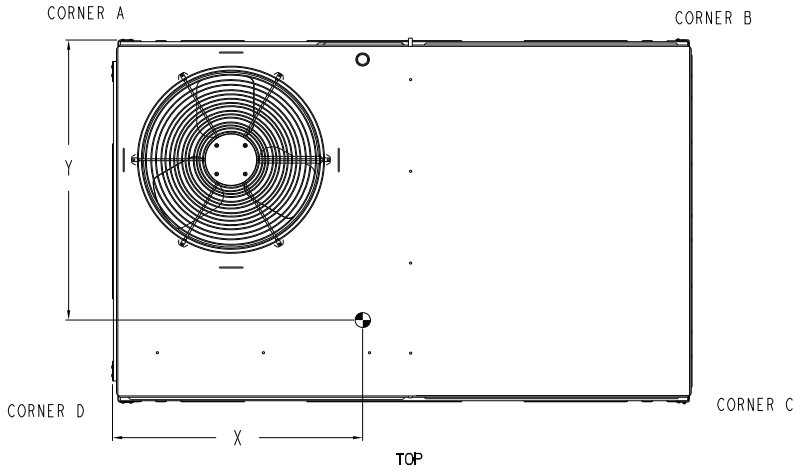

NOTE:
1. FOR ALL MINIMUM CLEARANCES LOCAL CODES OR JURISDICTIONS MAY PREVAIL.

SURFACE	CLEARANCE		OPERATING CLEARANCE
	SERVICE WITH: CONDUCTIVE BARRIER	SERVICE WITH: NONCONDUCTIVE BARRIER	
FRONT	48 [1219mm]	36 [914mm]	18 [457mm]
LEFT	48 [1219mm]	42 [1067mm]	18 [457mm]
BACK W/O HOOD	48 [1219mm]	42 [1067mm]	18 [457mm]
BACK W/ HOOD	36 [914mm]	36 [914mm]	18 [457mm]
RIGHT	36 [914mm]	36 [914mm]	18 [457mm]
TOP	72 [1829mm]	72 [1829mm]	72 [1829mm]

ITC CLASSIFICATION U.S. ECCN:NSR	SHEET 2 OF 3	DATE 11/20/23	SUPERCEDES -	50FE 04-07 SINGLE PACKAGE ELECTRICAL COOLING WITH ELECTRIC HEAT	48TC006965	REV -
-------------------------------------	-----------------	------------------	-----------------	-----------------------------------------------------------------	------------	----------



50FE-*04-07 Base Unit Dimensions (cont)

Carrier THIS DOCUMENT IS THE PROPERTY OF CARRIER CORPORATION AND IS DELIVERED UPON THE EXPRESS CONDITION THAT THE CONTENTS WILL NOT BE DISCLOSED OR USED WITHOUT CARRIER CORPORATION'S WRITTEN CONSENT. SUBMISSION OF THESE DRAWINGS OR DOCUMENTS DOES NOT CONSTITUTE PART PERFORMANCE OR ACCEPTANCE OF CONTRACT.

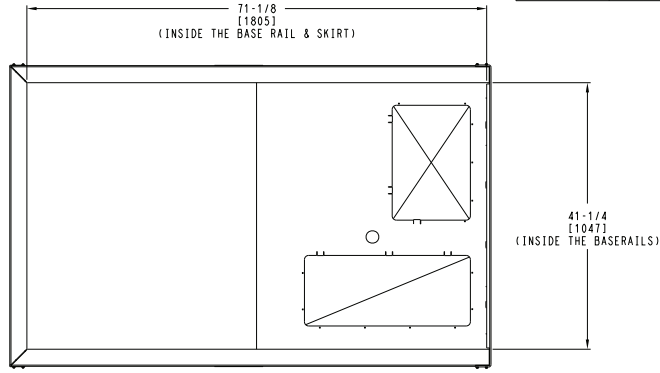
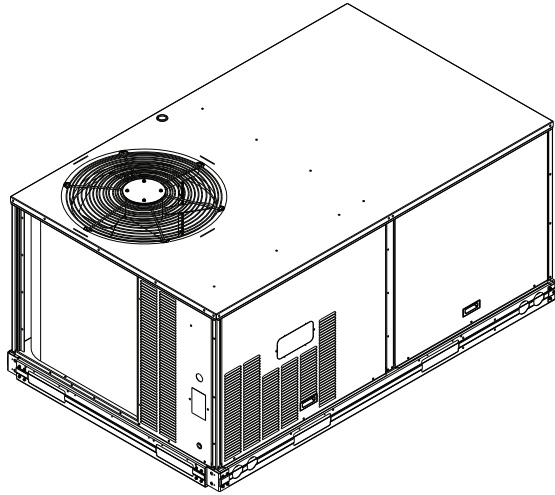

INSIDE BASERAIL DIMENSIONS
BOTTOM

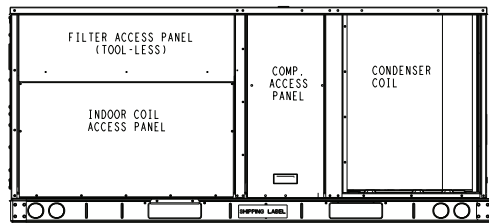
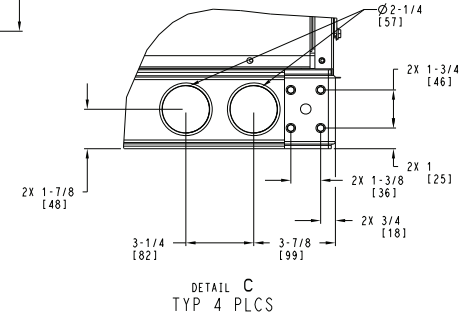

BACK

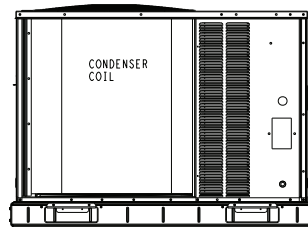

LEFT

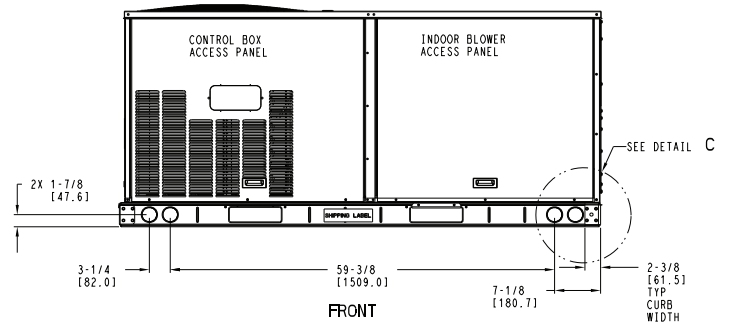

FRONT

ITC CLASSIFICATION	SHEET	DATE	SUPERCEDES	50FE 04-07 SINGLE PACKAGE ELECTRICAL COOLING WITH ELECTRIC HEAT	48TC006965	REV
U.S. ECCN:NSR	3 OF 3	11/20/23	-			-



Roof Curb Dimensions — 48/50FE 04-07

ROOF CURB ACCESSORY #	A
CRRFCURB001A01	14" [356]
CRRFCURB002A01	24" [610]

- NOTES:
 1. ROOFCURB ACCESSORY IS SHIPPED DISASSEMBLED.
 2. INSULATED PANELS: 25.4 [1"] THK. POLYURETHANE FOAM, 44.5 [1-3/4] # DENSITY.
 3. DIMENSIONS IN [] ARE IN MILLIMETERS.
 4. ROOFCURB: 18 GAGE STEEL.
 5. ATTACH DUCTWORK TO CURB. (FLANGES OF DUCT REST ON CURB).
 6. SERVICE CLEARANCE 4 FEET ON EACH SIDE.
 7. DIRECTION OF AIR FLOW.
 8. CONNECTOR PACKAGE CRBTMPWR001A01 IS FOR THRU-THE-CURB GAS TYPE PACKAGE CRBTMPWR003A01 IS FOR THRU-THE-BOTTOM TYPE GAS CONNECTIONS.

CONNECTOR PKG. ACC.	GAS CONNECTION TYPE	GAS FITTING	POWER WIRING FITTING	CONTROL WIRING FITTING	ACCESSORY CONVENIENCE OUTLET WIRING CONNECTOR
CRBTMPWR001A01	THRU THE CURB	3/4" [19] NPT	3/4" [19] NPT	1/2" [12.7] NPT	1/2" [12.7] NPT
CRBTMPWR003A01	THRU THE BOTTOM	1/2" [12.7] NPT			

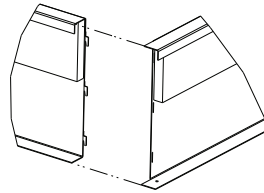
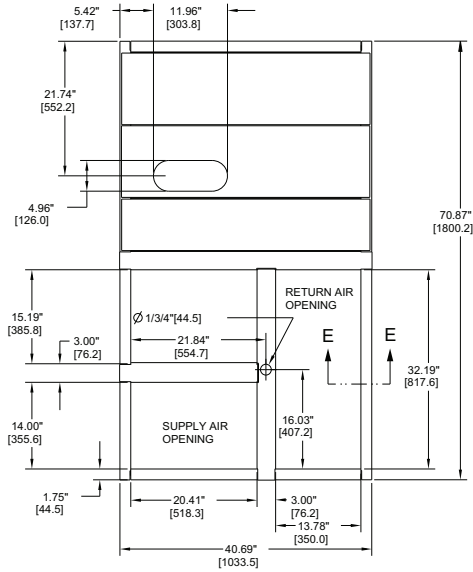

VIEW "B"
CORNER DETAIL

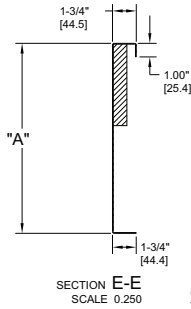
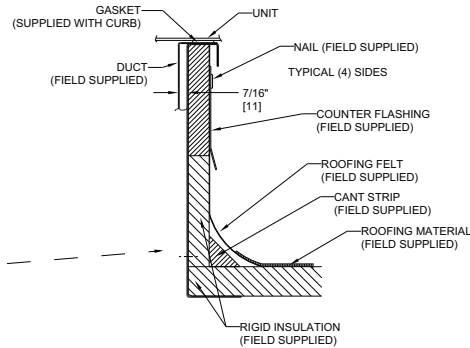

SECTION E-E
SCALE 0.250

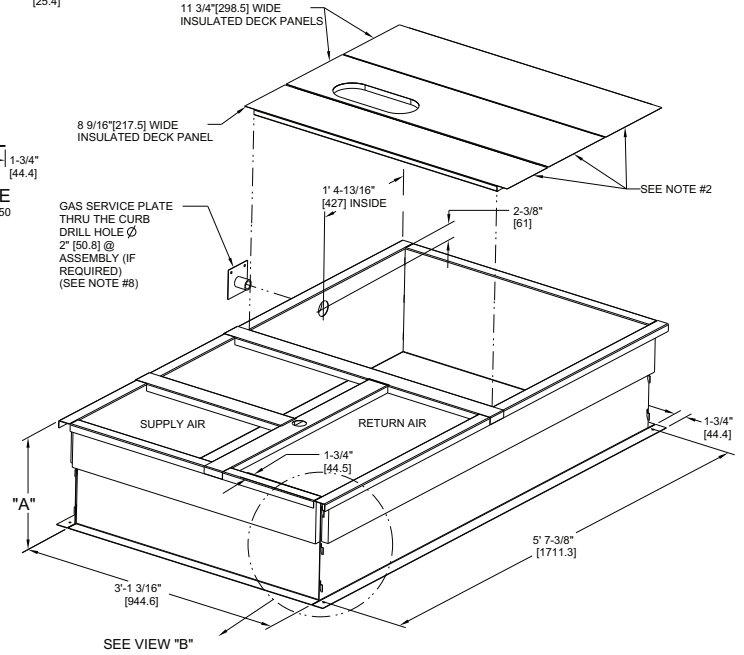

CERTIFIED DRAWING

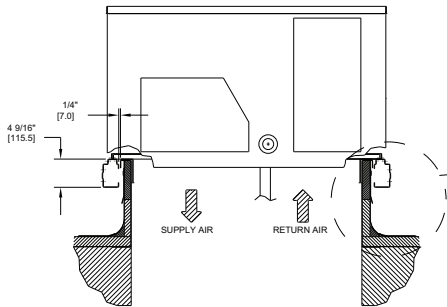

A	OVERALL DIM. 5'-7 3/8" WAS 5'-7 7/8"; 18GA MATERIAL WA 16 GA.; NAIL FIELD SUPPLIED WAS WITH CURB	04/22/13	MMC	-	-	1067898
REV	REVISION RECORD	DATE	BY	CHKD	APPD	ECN NO.

DRAWING RELEASE LEVEL:		PRODUCTION			TITLE		
THIRD ANGLE PROJECTION		UNLESS OTHERWISE SPECIFIED DIMENSIONS ARE IN INCHES TOLERANCES ON:			CURB ASY, ROOF		
MATERIAL	-	1 DEC ±	2 DEC ±	3 DEC ±	ANG ±	SHEET 5 OF 5	
ENGINEERING REQUIREMENTS	T-005, Y-002	AUTHORIZATION NUMBER			DRAWING NUMBER		
WEIGHT	-	1041738			48TC400427		
SURFACE FINISH	-	ENGINEERING	MANUFACTURING		SIZE	REV	
MFG/PURCH	PURCH	DRAFTER			CHECKER	B	
		MMC 06/17/11			D		
		MODEL (INTERNAL USE ONLY)			NEXT DRAWING	SCALE	DISTRIBUTION
					-	N/A	MMC



48/50FE*A04 Single Stage Cooling Capacities^{a,b}

48/50FE*A04			AMBIENT TEMPERATURE (°F)													
			85			95			105			115				
			EA (db)			EA (db)			EA (db)			EA (db)				
			75	80	85	75	80	85	75	80	85	75	80	85		
900 cfm	EA (wb)	58	TC	30.4	30.4	32.0	27.8	27.8	31.7	25.8	25.8	29.4	23.5	23.5	26.9	
			SHC	24.9	28.4	32.0	24.0	27.8	31.7	22.2	25.8	29.4	20.1	23.5	26.9	
		62	TC	32.4	32.4	32.4	29.8	29.8	30.4	26.9	26.9	28.8	24.1	24.1	27.1	
			SHC	23.3	27.5	31.8	21.8	26.1	30.4	20.3	24.5	28.8	18.7	22.9	27.1	
		67	TC	36.1	36.1	36.1	34.0	34.0	34.0	31.2	31.2	31.2	28.1	28.1	28.1	
			SHC	19.0	23.0	27.0	18.0	22.1	26.3	16.5	20.7	24.9	15.0	19.3	23.5	
	72	TC	39.5	39.5	39.5	37.8	37.8	37.8	35.4	35.4	35.4	32.7	32.7	32.7		
		SHC	15.0	18.6	22.2	14.0	17.8	21.6	12.7	16.6	20.5	11.4	15.4	19.4		
	76	TC	—	41.6	41.6	—	40.5	40.5	—	38.5	38.5	—	35.8	35.8		
		SHC	—	15.1	20.0	—	14.3	19.3	—	13.1	18.0	—	11.9	16.9		
	1050 cfm	EA (wb)	58	TC	31.9	31.9	36.1	29.8	29.8	33.9	27.6	27.6	31.5	25.3	25.3	28.9
				SHC	27.6	31.9	36.1	25.8	29.8	33.9	23.8	27.6	31.5	21.7	25.3	28.9
62			TC	33.6	33.6	34.9	31.0	31.0	33.5	28.2	28.2	31.8	25.3	25.3	30.1	
			SHC	25.1	30.0	34.9	23.7	28.6	33.5	22.1	27.0	31.8	20.5	25.3	30.1	
67			TC	37.3	37.3	37.3	35.1	35.1	35.1	32.5	32.5	32.5	29.2	29.2	29.2	
			SHC	20.1	24.7	29.2	19.1	23.9	28.6	17.9	22.8	27.7	16.3	21.2	26.1	
72		TC	40.4	40.4	40.4	38.8	38.8	38.8	36.4	36.4	36.4	33.7	33.7	33.7		
		SHC	15.3	19.4	23.5	14.4	18.8	23.2	13.2	17.7	22.3	11.9	16.5	21.2		
76		TC	—	42.5	42.5	—	41.3	41.3	—	39.3	39.3	—	36.8	36.8		
		SHC	—	15.4	21.2	—	14.8	20.5	—	13.8	19.6	—	12.6	16.6		
1200 cfm		EA (wb)	58	TC	33.5	33.5	38.0	31.5	31.5	35.8	29.2	29.2	33.3	26.8	26.8	30.6
				SHC	29.1	33.5	38.0	27.3	31.5	35.8	25.2	29.2	33.3	23.0	26.8	30.6
	62		TC	34.6	34.6	37.7	32.2	32.2	36.3	29.4	29.4	33.6	26.9	26.9	31.0	
			SHC	26.9	32.3	37.7	25.5	30.9	36.3	23.3	28.5	33.6	21.4	26.2	31.0	
	67		TC	38.2	38.2	38.2	36.0	36.0	36.0	33.4	33.4	33.4	30.0	30.0	30.0	
			SHC	21.1	26.2	31.2	20.2	25.5	30.8	19.1	24.6	30.2	17.5	23.1	28.6	
	72	TC	40.9	40.9	40.9	39.6	39.6	39.6	37.3	37.3	37.3	34.5	34.5	34.5		
		SHC	15.5	20.0	24.5	14.7	19.6	24.5	13.6	18.7	23.8	12.3	17.6	22.9		
	76	TC	—	43.1	43.1	—	41.8	41.8	—	40.1	40.1	—	37.5	37.5		
		SHC	—	15.6	22.2	—	15.1	19.3	—	14.3	19.0	—	13.2	18.0		
	1350 cfm	EA (wb)	58	TC	34.9	34.9	39.5	33.0	33.0	37.4	30.6	30.6	34.8	28.1	28.1	32.0
				SHC	30.3	34.9	39.5	28.6	33.0	37.4	26.4	30.6	34.8	24.2	28.1	32.0
62			TC	35.4	35.4	39.7	33.4	33.4	38.2	31.2	31.2	34.6	28.1	28.1	33.3	
			SHC	28.1	33.9	39.7	26.8	32.5	38.2	24.3	29.5	34.6	22.9	28.1	33.3	
67			TC	38.9	38.9	38.9	36.7	36.7	36.7	34.1	34.1	34.1	30.7	30.7	31.0	
			SHC	21.9	27.4	33.0	21.2	27.0	32.8	20.2	26.3	32.3	18.7	24.9	31.0	
72		TC	41.5	41.5	41.5	40.2	40.2	40.2	38.0	38.0	38.0	35.1	35.1	35.1		
		SHC	15.8	20.7	25.5	15.0	20.4	25.7	14.0	19.6	25.2	12.7	18.5	24.4		
76		TC	—	43.6	43.6	—	42.1	42.1	—	40.6	40.6	—	38.1	38.1		
		SHC	—	16.0	23.4	—	15.3	20.1	—	14.7	19.9	—	13.6	19.1		
1500 cfm		EA (wb)	58	TC	36.0	36.0	40.7	34.1	34.1	38.7	31.9	31.9	36.2	29.2	29.2	33.2
				SHC	31.2	36.0	40.7	29.6	34.1	38.7	27.5	31.9	36.2	25.1	29.2	33.2
	62		TC	36.8	36.8	39.6	34.2	34.2	40.3	31.2	31.2	37.7	29.2	29.2	34.6	
			SHC	28.4	34.0	39.6	28.1	34.2	40.3	24.8	31.2	37.7	23.8	29.2	34.6	
	67		TC	39.4	39.4	39.4	37.3	37.3	37.3	34.6	34.6	34.6	31.3	31.3	33.4	
			SHC	22.6	28.6	34.5	21.9	28.2	34.5	21.2	27.8	34.5	19.9	26.7	33.4	
	72	TC	42.0	42.0	42.0	40.7	40.7	40.7	38.5	38.5	38.5	35.6	35.6	35.6		
		SHC	15.9	21.2	26.4	15.2	21.0	26.8	14.2	20.3	26.5	13.0	19.4	25.8		
	76	TC	—	44.0	44.0	—	42.5	42.5	—	41.1	41.1	—	38.5	38.5		
		SHC	—	16.2	21.2	—	15.5	20.7	—	14.9	20.7	—	13.9	19.9		

NOTE(S):

- a. See minimum-maximum airflow ratings on page 9.
- b. Published capacity values are based on SEER2 static requirements.

LEGEND

- Do Not Operate
- cfm — Cubic Feet Per Minute (Supply Air)
- EA (db) — Entering Air Temperature (dry bulb)
- EA (wb) — Entering Air Temperature (wet bulb)
- SHC — Sensible Heat Capacity (1000 Btuh) Gross
- TC — Total Capacity (1000 Btuh) Gross

48/50FE*B04 — Unit with Humidi-MiZer® System in Subcooling Mode — Cooling Capacities^a

TEMP (°F) AIR ENTERING CONDENSER (Edb)		AIR ENTERING EVAPORATOR — SCFM/BF								
		900 / 0.01			1200 / 0.02			1500 / 0.04		
		Air Entering Evaporator — Ewb (°F)								
		72	67	62	72	67	62	72	67	62
75	TC	34.11	38.41	40.13	34.27	36.95	37.77	38.26	35.36	31.22
	SHC	33.96	20.21	4.34	24.30	19.78	14.92	13.58	17.65	21.22
	kW	3.13	2.99	2.94	2.82	2.74	2.68	3.09	3.01	2.88
85	TC	16.51	30.88	46.31	30.26	35.29	40.58	35.93	30.44	25.33
	SHC	24.05	14.60	5.25	21.77	18.79	15.68	11.33	14.25	17.13
	kW	3.47	3.19	3.01	3.22	3.01	2.84	3.39	3.18	2.99
95	TC	30.43	35.10	36.83	30.96	33.64	34.46	34.96	32.06	27.91
	SHC	31.80	18.23	2.35	22.31	17.79	12.93	11.59	15.66	19.23
	kW	3.66	3.53	3.48	3.36	3.28	3.22	3.63	3.55	3.42
105	TC	13.20	27.58	43.00	26.95	31.99	37.27	32.62	27.13	22.02
	SHC	22.06	12.61	3.25	19.78	16.80	13.69	9.33	12.26	15.14
	kW	4.01	3.72	3.55	3.76	3.55	3.38	3.93	3.72	3.53
115	TC	27.12	31.79	33.52	27.65	30.33	31.15	31.65	28.75	24.61
	SHC	29.81	16.23	0.36	20.32	15.80	10.94	9.60	13.67	17.23
	kW	4.20	4.07	4.02	3.90	3.82	3.76	4.17	4.09	3.96

NOTE(S):

a. Published capacity values are based on SEER2 static requirements.

48/50FE*B04 — Unit with Humidi-MiZer System in Hot Gas Reheat Mode — Cooling Capacities^a

TEMP (°F) AIR ENTERING CONDENSER (Edb)		AIR ENTERING EVAPORATOR — Ewb (°F)								
		75 Dry Bulb 62.5 Wet Bulb (50% Relative)			75 Dry Bulb 64 Wet Bulb (56% Relative)			75 Dry Bulb 65.3 Wet Bulb (60% Relative)		
		Air Entering Evaporator — Cfm								
		900	1200	1500	900	1200	1500	900	1200	1500
80	TC	11.85	12.53	12.78	12.40	13.06	13.31	12.87	13.51	13.77
	SHC	0.36	2.26	4.13	-1.28	0.18	1.67	-2.71	-1.61	-0.47
	kW	2.01	2.00	2.00	2.06	2.05	2.04	2.10	2.09	2.08
75	TC	12.70	13.42	13.69	13.27	13.96	14.23	13.71	14.41	14.69
	SHC	1.14	3.09	4.98	-0.48	1.01	2.53	-1.93	-0.79	0.39
	kW	1.99	1.98	1.98	2.04	2.03	2.02	2.08	2.07	2.06
70	TC	13.52	14.29	14.59	14.04	14.50	15.11	14.54	15.27	15.57
	SHC	1.92	3.89	5.82	0.22	1.40	3.35	-1.15	0.01	1.21
	kW	1.97	1.97	1.96	2.02	2.01	2.00	2.06	2.05	2.04
60	TC	15.10	15.94	16.28	15.65	16.46	16.80	16.09	16.90	17.25
	SHC	3.40	5.43	7.40	1.79	3.34	4.93	0.28	1.53	2.77
	kW	1.93	1.93	1.93	1.98	1.98	1.97	2.02	2.02	2.01
50	TC	16.56	17.47	17.85	17.08	18.00	18.38	17.61	18.47	18.84
	SHC	4.76	6.88	8.88	3.08	4.79	6.40	1.70	2.99	4.26
	kW	1.90	1.91	1.91	1.95	1.95	1.95	1.99	1.99	1.98
40	TC	18.01	18.99	19.40	18.51	19.53	19.95	19.08	20.00	20.42
	SHC	6.11	8.31	10.34	4.42	6.22	7.88	3.06	4.42	5.73
	kW	1.87	1.88	1.88	1.92	1.92	1.92	1.96	1.96	1.96

NOTE(S):

a. Published capacity values are based on SEER2 static requirements.

LEGEND

Edb	—	Entering Dry Bulb
Ewb	—	Entering Wet Bulb
kW	—	Compressor Power Input
SCFM/BF	—	Standard Cubic Feet per Minute/Bypass Factor
SHC	—	Sensible Heat Capacity (1000 Btuh) Gross
TC	—	Total Capacity (1000 Btuh) Gross

48/50FE*A05 Single Stage Cooling Capacities^{a,b}

48/50FE*A05			AMBIENT TEMPERATURE (°F)														
			85			95			105			115					
			EA (db)			EA (db)			EA (db)			EA (db)					
1200 cfm	EA (wb)		75	80	85	75	80	85	75	80	85	75	80	85			
			1200 cfm	EA (wb)	58	TC	43.1	43.1	49.0	40.2	40.2	45.8	—	—	—	—	—
SHC	37.2	43.1				49.0	34.6	40.2	45.8	—	—	—	—	—	—	—	
62	TC	46.6			46.6	46.6	43.1	43.1	43.8	—	—	—	—	—	—	—	
	SHC	33.4			39.7	46.0	31.2	37.5	43.8	—	—	—	—	—	—	—	
67	TC	52.3			52.3	52.3	49.0	49.0	49.0	44.9	44.9	44.9	40.1	40.1	40.1	40.1	
	SHC	27.5			33.8	40.1	25.6	31.9	38.3	23.4	29.7	36.0	20.9	27.2	33.5	33.5	
72	TC	57.7			57.7	57.7	54.7	54.7	54.7	51.2	51.2	51.2	46.8	46.8	46.8	46.8	
	SHC	21.2			27.5	33.8	19.5	25.8	32.2	17.6	24.0	30.3	15.4	21.7	28.1	28.1	
76	TC	—			61.4	61.4	—	58.6	58.6	—	55.4	55.4	—	51.9	51.9	51.9	
	SHC	—			22.2	28.8	—	20.6	27.2	—	18.9	25.5	—	17.1	23.6	23.6	
1400 cfm	EA (wb)	58			TC	46.3	46.3	52.6	43.3	43.3	49.3	39.8	39.8	45.5	—	—	—
					SHC	40.0	46.3	52.6	37.3	43.3	49.3	34.2	39.8	45.5	—	—	—
		62	TC	48.6	48.6	51.1	45.0	45.0	48.9	40.8	40.8	46.2	—	—	—		
			SHC	36.5	43.8	51.1	34.4	41.6	48.9	31.9	39.0	46.2	—	—	—		
		67	TC	54.2	54.2	54.2	50.9	50.9	50.9	47.0	47.0	47.0	41.9	41.9	41.9		
			SHC	29.4	36.7	44.0	27.6	34.9	42.2	25.5	32.9	40.2	23.0	30.3	37.5		
		72	TC	59.3	59.3	59.3	56.3	56.3	56.3	52.9	52.9	52.9	48.7	48.7	48.7		
			SHC	22.0	29.1	36.3	20.3	27.5	34.7	18.5	25.8	33.1	16.4	23.8	31.1		
		76	TC	—	62.7	62.7	—	59.9	59.9	—	56.6	56.6	—	53.2	53.2		
			SHC	—	23.1	30.7	—	21.5	29.1	—	19.8	27.3	—	18.0	25.4		
		1600 cfm	EA (wb)	58	TC	49.0	49.0	55.6	46.0	46.0	52.3	42.4	42.4	48.4	38.5	38.5	44.0
					SHC	42.4	49.0	55.6	39.7	46.0	52.3	36.5	42.4	48.4	33.0	38.5	44.0
62	TC			50.2	50.2	55.7	46.7	46.7	53.5	43.5	43.5	47.9	38.6	38.6	46.0		
	SHC			39.3	47.5	55.7	37.2	45.4	53.5	33.4	40.6	47.9	31.1	38.6	46.0		
67	TC			55.6	55.6	55.6	52.3	52.3	52.3	48.5	48.5	48.5	43.2	43.2	43.2		
	SHC			31.2	39.3	47.5	29.4	37.7	45.9	27.5	35.8	44.1	24.9	33.2	41.4		
72	TC			60.5	60.5	60.5	57.5	57.5	57.5	54.1	54.1	54.1	50.1	50.1	50.1		
	SHC			22.6	30.5	38.4	20.9	29.0	37.0	19.2	27.3	35.5	17.2	25.5	33.9		
76	TC			—	63.7	63.7	—	60.9	60.9	—	57.6	57.6	—	54.1	54.1		
	SHC			—	23.7	32.1	—	22.2	30.5	—	20.4	28.7	—	18.7	27.1		
1800 cfm	EA (wb)			58	TC	51.2	51.2	58.0	48.3	48.3	54.8	44.7	44.7	50.9	40.6	40.6	46.4
					SHC	44.3	51.2	58.0	41.7	48.3	54.8	38.5	44.7	50.9	34.8	40.6	46.4
		62	TC	51.6	51.6	59.7	49.2	49.2	54.1	44.7	44.7	53.0	40.6	40.6	48.3		
			SHC	41.8	50.8	59.7	38.1	46.1	54.1	36.4	44.7	53.0	32.9	40.6	48.3		
		67	TC	56.7	56.7	56.7	53.4	53.4	53.4	49.6	49.6	49.6	44.3	44.3	45.1		
			SHC	32.7	41.8	50.8	31.1	40.2	49.3	29.2	38.5	47.7	26.7	35.9	45.1		
		72	TC	61.3	61.3	61.3	58.3	58.3	58.3	54.9	54.9	54.9	51.1	51.1	51.1		
			SHC	23.1	31.7	40.3	21.5	30.3	39.1	19.7	28.7	37.7	17.9	27.1	36.3		
		76	TC	—	64.4	64.4	—	61.6	61.6	—	58.3	58.3	—	54.8	54.8		
			SHC	—	24.2	33.2	—	22.7	31.6	—	21.0	29.9	—	19.3	28.4		
		2000 cfm	EA (wb)	58	TC	53.0	53.0	60.0	50.1	50.1	56.9	46.7	46.7	53.2	42.4	42.4	48.4
					SHC	46.0	53.0	60.0	43.3	50.1	56.9	40.3	46.7	53.2	36.4	42.4	48.4
62	TC			54.4	54.4	57.7	50.2	50.2	59.2	46.8	46.8	55.4	42.4	42.4	50.5		
	SHC			41.3	49.5	57.7	41.1	50.2	59.2	38.2	46.8	55.4	34.4	42.4	50.5		
67	TC			57.5	57.5	57.5	54.3	54.3	54.3	50.4	50.4	51.1	45.3	45.3	48.7		
	SHC			34.2	44.0	53.8	32.6	42.6	52.5	30.9	41.0	51.1	28.5	38.6	48.7		
72	TC			62.0	62.0	62.0	59.0	59.0	59.0	55.6	55.6	55.6	51.8	51.8	51.8		
	SHC			23.4	32.7	42.0	21.9	31.4	40.9	20.2	29.9	39.6	18.4	28.4	38.5		
76	TC			—	65.0	65.0	—	62.2	62.2	—	58.9	58.9	—	55.3	55.3		
	SHC			—	24.5	34.0	—	23.0	32.6	—	21.3	31.0	—	19.7	29.4		

NOTE(S):

- a. See minimum-maximum airflow ratings on page 9.
- b. Published capacity values are based on SEER2 static requirements.

LEGEND

- Do Not Operate
- cfm — Cubic Feet Per Minute (Supply Air)
- EA (db) — Entering Air Temperature (dry bulb)
- EA (wb) — Entering Air Temperature (wet bulb)
- SHC — Sensible Heat Capacity (1000 Btuh) Gross
- TC — Total Capacity (1000 Btuh) Gross

48/50FE*B05 — Unit with Humidi-MiZer® System in Subcooling Mode — Cooling Capacities^a

TEMP (°F) AIR ENTERING CONDENSER (Edb)		AIR ENTERING EVAPORATOR — SCFM/BF								
		1200 / 0.04			1600 / 0.07			2000 / 0.10		
		Air Entering Evaporator — Ewb (°F)								
		72	67	62	72	67	62	72	67	62
75	TC	49.74	44.94	40.58	51.90	48.81	42.51	54.80	49.82	43.50
	SHC	20.80	26.22	31.65	29.75	25.13	43.61	26.80	35.16	16.70
	kW	2.50	2.47	2.44	4.03	4.06	4.09	2.53	2.50	2.53
85	TC	48.80	39.77	40.20	50.40	43.47	41.92	53.40	44.30	44.74
	SHC	17.29	24.04	28.65	25.72	22.81	40.42	22.88	32.69	39.87
	kW	2.53	2.51	2.48	4.07	4.09	4.12	2.56	2.53	2.51
95	TC	47.42	34.60	39.40	49.19	38.12	40.95	51.77	38.77	43.67
	SHC	13.40	21.87	25.30	22.02	20.49	36.91	18.78	30.21	36.26
	kW	2.57	2.54	2.52	4.11	4.13	4.16	2.60	2.57	2.55
105	TC	45.19	29.43	26.14	46.71	32.78	29.29	49.33	33.25	30.03
	SHC	8.71	19.70	26.16	17.11	18.18	25.97	13.90	27.73	36.70
	kW	4.52	2.58	2.57	2.92	4.17	4.19	4.55	2.61	2.59
115	TC	42.92	24.26	21.01	43.68	27.43	24.26	46.65	27.73	24.63
	SHC	4.05	17.53	24.01	11.67	15.86	23.94	8.85	25.25	34.25
	kW	5.41	2.62	2.61	3.81	4.21	4.22	5.43	2.64	2.63

NOTE(S):

a. Published capacity values are based on SEER2 static requirements.

48/50FE*B05 — Unit with Humidi-MiZer System in Hot Gas Reheat Mode — Cooling Capacities^a

TEMP (°F) AIR ENTERING CONDENSER (Edb)		AIR ENTERING EVAPORATOR — Ewb (°F)								
		75 Dry Bulb 62.5 Wet Bulb (50% Relative)			75 Dry Bulb 64 Wet Bulb (56% Relative)			75 Dry Bulb 65.3 Wet Bulb (60% Relative)		
		Air Entering Evaporator — Cfm								
		1200	1600	2000	1200	1600	2000	1200	1600	2000
80	TC	11.65	11.44	11.20	13.18	12.98	12.73	13.47	13.26	12.88
	SHC	-3.80	-3.40	-2.95	7.77	8.17	8.61	-6.99	-6.98	-6.99
	kW	3.19	3.20	3.20	3.68	3.69	3.69	3.26	3.27	3.27
75	TC	13.89	13.76	13.47	13.54	13.41	13.12	15.39	15.37	15.03
	SHC	-1.54	-1.09	-0.76	6.74	7.19	7.51	-4.70	-4.51	-4.54
	kW	3.07	3.08	3.09	3.63	3.64	3.65	3.13	3.15	3.16
70	TC	15.98	15.88	15.60	16.91	16.82	16.53	17.40	17.12	16.67
	SHC	0.68	1.11	1.36	-1.25	-0.83	-0.57	-2.23	-2.21	-2.36
	kW	2.96	2.97	2.98	3.00	3.01	3.02	3.01	3.02	3.01
60	TC	19.24	19.18	18.82	17.30	17.24	16.88	20.43	19.98	24.36
	SHC	4.77	5.17	5.26	-2.20	-1.80	-1.71	2.67	2.62	4.24
	kW	3.21	3.26	3.18	2.90	2.96	2.88	3.26	2.97	3.02
50	TC	13.45	13.58	13.53	14.97	15.11	15.06	13.88	14.00	13.95
	SHC	7.82	7.54	7.16	3.56	3.29	2.91	7.06	6.66	6.19
	kW	3.04	3.10	3.15	3.40	3.47	3.51	3.10	3.17	3.21
40	TC	13.45	13.58	13.53	15.40	15.53	15.48	13.88	14.00	13.95
	SHC	7.82	7.54	7.16	2.59	2.31	1.93	7.06	6.66	6.19
	kW	3.14	3.23	3.15	3.33	3.42	3.34	3.22	3.31	3.01

NOTE(S):

a. Published capacity values are based on SEER2 static requirements.

LEGEND

Edb	—	Entering Dry Bulb
Ewb	—	Entering Wet Bulb
kW	—	Compressor Power Input
SCFM/BF	—	Standard Cubic Feet per Minute/Bypass Factor
SHC	—	Sensible Heat Capacity (1000 Btuh) Gross
TC	—	Total Capacity (1000 Btuh) Gross

48/50FE*A06 Single Stage Cooling Capacities^{a,b}

48/50FE*A06			AMBIENT TEMPERATURE (°F)													
			85			95			105			115				
			EA (db)			EA (db)			EA (db)			EA (db)				
			75	80	85	75	80	85	75	80	85	75	80	85		
1500 cfm	EA (wb)	58	TC	52.7	52.7	59.6	49.6	49.6	56.1	46.1	46.1	52.3	42.4	42.4	48.2	
			SHC	45.7	52.7	59.6	43.0	49.6	56.1	40.0	46.1	52.3	36.7	42.4	48.2	
		62	TC	56.1	56.1	56.6	52.2	52.2	54.8	47.7	47.7	52.4	42.8	42.8	49.7	
			SHC	41.4	49.0	56.6	39.5	47.1	54.8	37.1	44.8	52.4	34.6	42.1	49.7	
		67	TC	61.6	61.6	61.6	58.7	58.7	58.7	54.5	54.5	54.5	49.5	49.5	49.5	
			SHC	33.7	40.8	48.0	32.5	40.0	47.4	30.6	38.1	45.7	28.3	35.9	43.5	
	72	TC	66.5	66.5	66.5	64.6	64.6	64.6	60.9	60.9	60.9	56.4	56.4	56.4		
		SHC	26.3	33.0	39.7	25.2	32.3	39.3	23.5	30.8	38.0	21.5	28.9	36.3		
	76	TC	—	69.8	69.8	—	67.6	67.6	—	65.4	65.4	—	61.3	61.3		
		SHC	—	26.8	35.0	—	25.6	33.9	—	24.6	30.5	—	23.0	29.8		
	1750 cfm	EA (wb)	58	TC	56.0	56.0	63.3	53.0	53.0	59.9	49.4	49.4	56.0	45.4	45.4	51.6
				SHC	48.7	56.0	63.3	46.0	53.0	59.9	42.8	49.4	56.0	39.3	45.4	51.6
62			TC	58.1	58.1	62.1	54.2	54.2	60.5	49.8	49.8	57.7	46.4	46.4	50.7	
			SHC	44.8	53.4	62.1	42.9	51.7	60.5	40.4	49.0	57.7	36.0	43.3	50.7	
67			TC	63.8	63.8	63.8	60.6	60.6	60.6	56.3	56.3	56.3	51.3	51.3	51.3	
			SHC	35.9	44.1	52.3	34.7	43.2	51.8	32.8	41.5	50.2	30.6	39.4	48.2	
72		TC	67.9	67.9	67.9	66.0	66.0	66.0	62.6	62.6	62.6	58.0	58.0	58.0		
		SHC	26.9	34.5	42.0	26.0	34.0	42.1	24.4	32.8	41.2	22.5	31.0	39.5		
76		TC	—	71.2	71.2	—	68.8	68.8	—	66.5	66.5	—	62.7	62.7		
		SHC	—	27.4	37.0	—	26.5	33.6	—	25.6	33.4	—	24.1	32.1		
2000 cfm		EA (wb)	58	TC	58.7	58.7	66.3	55.7	55.7	63.0	52.1	52.1	59.0	48.0	48.0	54.5
				SHC	51.1	58.7	66.3	48.4	55.7	63.0	45.2	52.1	59.0	41.6	48.0	54.5
	62		TC	59.7	59.7	67.0	56.8	56.8	63.2	52.5	52.5	60.5	48.1	48.1	56.7	
			SHC	47.7	57.4	67.0	45.0	54.1	63.2	42.5	51.5	60.5	39.5	48.1	56.7	
	67		TC	64.8	64.8	64.8	62.0	62.0	62.0	57.7	57.7	57.7	52.7	52.7	52.7	
			SHC	37.3	46.3	55.2	36.6	46.2	55.8	34.9	44.7	54.5	32.8	42.7	52.7	
	72	TC	69.0	69.0	69.0	66.7	66.7	66.7	63.8	63.8	63.8	59.2	59.2	59.2		
		SHC	27.5	35.8	44.0	26.5	35.3	44.1	25.2	34.6	44.0	23.4	33.0	42.6		
	76	TC	—	72.2	72.2	—	69.7	69.7	—	67.3	67.3	—	63.6	63.6		
		SHC	—	28.3	36.2	—	27.2	35.4	—	26.4	35.3	—	25.0	34.2		
	2250 cfm	EA (wb)	58	TC	60.9	60.9	68.8	57.9	57.9	65.5	54.4	54.4	61.5	50.2	50.2	56.9
				SHC	53.0	60.9	68.8	50.3	57.9	65.5	47.2	54.4	61.5	43.5	50.2	56.9
62			TC	61.8	61.8	70.1	58.7	58.7	66.2	54.4	54.4	64.0	50.3	50.3	59.3	
			SHC	49.8	60.0	70.1	47.0	56.6	66.2	44.8	54.4	64.0	41.3	50.3	59.3	
67			TC	65.6	65.6	65.6	63.1	63.1	63.1	58.8	58.8	58.8	53.6	53.6	56.9	
			SHC	38.6	48.4	58.1	38.4	48.9	59.5	36.8	47.7	58.6	34.7	45.8	56.9	
72		TC	69.7	69.7	69.7	67.3	67.3	67.3	64.8	64.8	64.8	60.2	60.2	60.2		
		SHC	28.0	36.9	45.8	26.9	36.4	45.8	26.0	36.3	46.6	24.1	34.8	45.4		
76		TC	—	73.0	73.0	—	70.4	70.4	—	67.8	67.8	—	64.4	64.4		
		SHC	—	29.1	37.9	—	28.0	37.0	—	27.1	36.7	—	25.9	36.1		
2500 cfm		EA (wb)	58	TC	62.6	62.6	70.7	59.8	59.8	67.6	56.2	56.2	63.7	52.1	52.1	59.1
				SHC	54.5	62.6	70.7	52.0	59.8	67.6	48.8	56.2	63.7	45.2	52.1	59.1
	62		TC	64.3	64.3	69.0	59.9	59.9	70.3	56.3	56.3	66.2	52.2	52.2	61.5	
			SHC	49.8	59.4	69.0	49.4	59.9	70.3	46.4	56.3	66.2	42.9	52.2	61.5	
	67		TC	66.3	66.3	66.3	63.9	63.9	63.9	59.7	59.7	62.4	54.4	54.4	60.8	
			SHC	39.9	50.4	60.8	40.0	51.5	63.0	38.6	50.5	62.4	36.6	48.7	60.8	
	72	TC	70.4	70.4	70.4	67.9	67.9	67.9	65.3	65.3	65.3	60.9	60.9	60.9		
		SHC	28.5	38.1	47.6	27.4	37.6	47.7	26.6	37.7	48.9	24.9	36.5	48.1		
	76	TC	—	73.6	73.6	—	70.9	70.9	—	68.1	68.1	—	64.9	64.9		
		SHC	—	29.8	39.4	—	28.6	38.5	—	27.6	37.8	—	26.7	37.8		

NOTE(S):

- a. See minimum-maximum airflow ratings on page 9.
- b. Published capacity values are based on SEER2 static requirements.

LEGEND

- Do Not Operate
- cfm — Cubic Feet Per Minute (Supply Air)
- EA (db) — Entering Air Temperature (dry bulb)
- EA (wb) — Entering Air Temperature (wet bulb)
- SHC — Sensible Heat Capacity (1000 Btuh) Gross
- TC — Total Capacity (1000 Btuh) Gross

48/50FE*B06 — Unit with Humidi-MiZer® System in Subcooling Mode — Cooling Capacities^a

TEMP (°F) AIR ENTERING CONDENSER (Edb)		AIR ENTERING EVAPORATOR — SCFM/BF								
		1500 / 0.01			2000 / 0.02			2500 / 0.03		
		Air Entering Evaporator — Ewb (°F)								
		72	67	62	72	67	62	72	67	62
75	TC	72.90	66.35	61.02	76.45	70.00	64.32	78.39	71.96	66.80
	SHC	27.40	35.54	44.24	29.57	40.50	51.23	30.19	43.54	55.90
	kW	3.90	3.85	3.82	4.16	4.20	4.27	4.58	4.54	4.50
85	TC	67.90	62.19	56.96	71.45	65.84	60.26	73.39	67.79	62.74
	SHC	23.50	32.46	41.23	25.67	37.42	48.22	26.29	40.46	52.89
	kW	4.30	4.26	4.22	4.56	4.61	4.67	4.98	4.95	4.90
95	TC	62.90	58.03	52.89	67.64	62.00	57.13	67.35	61.66	57.24
	SHC	19.60	29.38	38.23	20.43	32.10	43.58	19.95	34.00	47.00
	kW	4.70	4.67	4.62	5.16	5.20	5.25	5.69	5.64	5.60
105	TC	57.90	53.86	48.83	62.64	57.84	53.07	62.35	57.49	53.18
	SHC	15.70	26.30	35.22	16.53	29.02	40.58	16.05	30.92	43.99
	kW	5.10	5.08	5.02	5.56	5.61	5.65	6.09	6.05	6.00
115	TC	48.70	44.15	40.08	48.53	43.70	39.65	52.59	47.98	44.30
	SHC	9.00	19.05	28.91	7.27	19.70	31.91	8.35	23.43	36.50
	kW	6.10	6.05	6.00	6.35	6.40	6.45	6.79	6.74	6.70

NOTE(S):

a. Published capacity values are based on SEER2 static requirements.

48/50FE*B06 — Unit with Humidi-MiZer System in Hot Gas Reheat Mode — Cooling Capacities^a

TEMP (°F) AIR ENTERING CONDENSER (Edb)		AIR ENTERING EVAPORATOR — Ewb (°F)								
		75 Dry Bulb 62.5 Wet Bulb (50% Relative)			75 Dry Bulb 64 Wet Bulb (56% Relative)			75 Dry Bulb 65.3 Wet Bulb (60% Relative)		
		Air Entering Evaporator — Cfm								
		1500	2000	2500	1500	2000	2500	1500	2000	2500
80	TC	19.31	19.07	18.83	23.35	23.09	22.78	26.78	26.52	26.14
	SHC	-1.12	-0.29	0.61	1.79	2.29	3.76	5.80	6.05	6.32
	kW	3.64	3.64	3.65	4.10	4.11	4.75	4.72	4.72	4.73
75	TC	20.69	20.63	19.31	24.36	23.43	22.96	21.93	21.88	20.51
	SHC	2.63	5.39	7.58	0.49	-2.30	3.92	-3.24	-1.91	-1.12
	kW	3.62	4.02	4.65	3.71	4.10	4.74	3.79	4.18	4.81
70	TC	21.79	21.77	20.49	22.45	22.44	21.13	20.03	20.02	18.68
	SHC	3.67	6.48	8.69	0.53	2.56	4.03	-2.20	-0.84	-0.01
	kW	3.60	4.00	4.63	3.69	4.09	4.72	3.60	4.16	4.79
60	TC	23.92	23.97	22.74	24.60	24.66	23.40	25.19	25.25	23.96
	SHC	5.70	8.58	10.84	2.57	4.67	6.19	-1.16	0.28	1.16
	kW	3.57	3.97	4.61	3.66	4.06	4.69	3.73	4.13	4.77
50	TC	20.07	20.13	18.94	24.00	23.83	22.61	24.27	24.09	22.87
	SHC	6.56	10.63	12.95	5.39	5.73	7.31	4.92	5.18	6.70
	kW	3.31	3.95	4.58	3.75	3.68	4.67	3.78	3.71	4.70
40	TC	22.03	22.23	21.08	28.75	28.95	27.77	29.37	29.57	28.37
	SHC	9.62	12.64	15.02	6.51	8.76	10.38	3.79	5.38	6.36
	kW	3.51	3.92	4.56	3.59	4.00	4.65	3.67	4.08	4.72

NOTE(S):

a. Published capacity values are based on SEER2 static requirements.

LEGEND

Edb	—	Entering Dry Bulb
Ewb	—	Entering Wet Bulb
kW	—	Compressor Power Input
SCFM/BF	—	Standard Cubic Feet per Minute/Bypass Factor
SHC	—	Sensible Heat Capacity (1000 Btu/h) Gross
TC	—	Total Capacity (1000 Btu/h) Gross



48/50FE*M07 High Stage Cooling Capacities^{a,b}

48/50FE*M07				AMBIENT TEMPERATURE (°F)												
				85			95			105			115			
				EA (db)			EA (db)			EA (db)			EA (db)			
				75	80	85	75	80	85	75	80	85	75	80	85	
1800 cfm	EA (wb)	58	TC	65.4	65.4	74.3	62.1	62.1	70.8	58.7	58.7	67.1	55.2	55.2	63.2	
			SHC	56.4	65.4	74.3	53.5	62.1	70.8	50.4	58.7	67.1	47.2	55.2	63.2	
		62	TC	69.3	69.3	69.9	65.4	65.4	67.5	61.2	61.2	65.0	56.9	56.9	62.5	
			SHC	50.4	60.2	69.9	48.1	57.8	67.5	45.6	55.3	65.0	43.2	52.8	62.5	
		67	TC	76.7	76.7	76.7	72.5	72.5	72.5	68.1	68.1	68.1	63.5	63.5	63.5	
			SHC	41.1	50.8	60.6	38.7	48.5	58.2	36.3	46.1	55.8	33.9	43.6	53.3	
	72	TC	84.8	84.8	84.8	80.2	80.2	80.2	75.5	75.5	75.5	70.6	70.6	70.6		
		SHC	31.6	41.4	51.2	29.2	39.0	48.8	26.8	36.6	46.4	24.4	34.1	43.9		
	76	TC	—	91.6	91.6	—	86.8	86.8	—	81.8	81.8	—	76.6	76.6		
		SHC	—	33.6	43.5	—	31.3	41.2	—	28.9	38.8	—	26.5	36.4		
	2100 cfm	EA (wb)	58	TC	69.5	69.5	79.0	66.1	66.1	75.2	62.5	62.5	71.2	58.7	58.7	67.1
				SHC	60.1	69.5	79.0	57.0	66.1	75.2	53.7	62.5	71.2	50.3	58.7	67.1
62			TC	71.8	71.8	77.4	67.6	67.6	74.9	63.4	63.4	72.3	59.0	59.0	69.5	
			SHC	55.0	66.2	77.4	52.5	63.7	74.9	50.0	61.2	72.3	47.4	58.4	69.5	
67			TC	79.2	79.2	79.2	74.7	74.7	74.7	70.1	70.1	70.1	65.3	65.3	65.3	
			SHC	44.0	55.3	66.6	41.6	52.9	64.2	39.1	50.4	61.7	36.7	47.9	59.2	
72		TC	87.3	87.3	87.3	82.6	82.6	82.6	77.7	77.7	77.7	72.5	72.5	72.5		
		SHC	32.8	44.1	55.5	30.4	41.7	53.1	28.0	39.3	50.6	25.5	36.8	48.1		
76		TC	—	94.2	94.2	—	89.2	89.2	—	83.9	83.9	—	78.5	78.5		
		SHC	—	35.1	46.6	—	32.7	44.2	—	30.3	41.7	—	27.7	39.1		
2400 cfm		EA (wb)	58	TC	73.0	73.0	82.8	69.3	69.3	78.8	65.5	65.5	74.7	61.6	61.6	70.3
				SHC	63.1	73	82.8	59.8	69.3	78.8	56.4	65.5	74.7	52.8	61.6	70.3
	62		TC	73.8	73.8	84.5	70.2	70.2	79.6	65.6	65.6	77.8	61.6	61.6	73.3	
			SHC	59.2	71.8	84.5	55.6	67.6	79.6	53.5	65.6	77.8	50.0	61.6	73.3	
	67		TC	81.0	81.0	81.0	76.4	76.4	76.4	71.7	71.7	71.7	66.7	66.7	66.7	
			SHC	46.7	59.5	72.4	44.3	57.1	69.9	41.8	54.6	67.4	39.3	52.1	64.9	
	72	TC	89.2	89.2	89.2	84.4	84.4	84.4	79.3	79.3	79.3	74.0	74.0	74.0		
		SHC	33.8	46.7	59.5	31.4	44.3	57.1	29.0	41.8	54.6	26.5	39.2	52.0		
	76	TC	—	96.1	96.1	—	90.9	90.9	—	85.4	85.4	—	79.8	79.8		
		SHC	—	36.3	49.3	—	33.9	46.8	—	31.3	44.2	—	28.8	41.5		
	2700 cfm	EA (wb)	58	TC	75.9	75.9	86.1	72.1	72.1	81.9	68.1	68.1	77.5	64.0	64.0	73.0
				SHC	65.7	75.9	86.1	62.3	72.1	81.9	58.7	68.1	77.5	54.9	64.0	73.0
62			TC	76.0	76.0	89.5	72.2	72.2	85.2	68.2	68.2	80.7	64.0	64.0	76.0	
			SHC	62.4	76.0	89.5	59.1	72.2	85.2	55.6	68.2	80.7	52.0	64.0	76.0	
67			TC	82.5	82.5	82.5	77.8	77.8	77.8	72.9	72.9	73.0	67.8	67.8	70.4	
			SHC	49.3	63.7	78.0	46.9	61.2	75.5	44.4	58.7	73.0	41.9	56.1	70.4	
72		TC	90.8	90.8	90.8	85.7	85.7	85.7	80.5	80.5	80.5	75.1	75.1	75.1		
		SHC	34.8	49.1	63.4	32.4	46.7	61.0	29.9	44.1	58.4	27.3	41.6	55.8		
76		TC	—	97.6	97.6	—	92.2	92.2	—	86.5	86.5	—	80.7	80.7		
		SHC	—	37.3	51.7	—	34.8	49.1	—	32.3	46.4	—	29.6	43.6		
3000 cfm		EA (wb)	58	TC	78.4	78.4	88.8	74.4	74.4	84.5	70.3	70.3	80.0	66.0	66.0	75.2
				SHC	67.9	78.4	88.8	64.3	74.4	84.5	60.6	70.3	80.0	56.7	66.0	75.2
	62		TC	78.5	78.5	92.4	74.5	74.5	87.9	70.4	70.4	83.3	66.1	66.1	78.4	
			SHC	64.5	78.5	92.4	61.1	74.5	87.9	57.5	70.4	83.3	53.7	66.1	78.4	
	67		TC	83.6	83.6	83.6	78.8	78.8	81.0	73.9	73.9	78.4	68.7	68.7	75.7	
			SHC	51.9	67.7	83.5	49.4	65.2	81.0	46.9	62.7	78.4	44.4	60.0	75.7	
	72	TC	92.0	92.0	92.0	86.9	86.9	86.9	81.5	81.5	81.5	76.0	76.0	76.0		
		SHC	35.6	51.4	67.2	33.2	48.9	64.7	30.7	46.4	62.1	28.2	43.8	59.5		
	76	TC	—	98.7	98.7	—	93.2	93.2	—	87.4	87.4	—	81.4	81.4		
		SHC	—	38.2	53.9	—	35.7	51.2	—	33.0	48.4	—	30.3	45.4		

NOTE(S):

- a. See minimum-maximum airflow ratings on page 9.
- b. Published capacity values are based on SEER2 static requirements.

LEGEND

- Do Not Operate
- cfm — Cubic Feet Per Minute (Supply Air)
- EA (db) — Entering Air Temperature (dry bulb)
- EA (wb) — Entering Air Temperature (wet bulb)
- SHC — Sensible Heat Capacity (1000 Btuh) Gross
- TC — Total Capacity (1000 Btuh) Gross



48/50FE*M07 Low Stage Cooling Capacities^{a,b}

48/50FE*M07			AMBIENT TEMPERATURE (°F)													
			85			95			105			115				
			EA (db)			EA (db)			EA (db)			EA (db)				
			75	80	85	75	80	85	75	80	85	75	80	85		
1200 cfm	EA (wb)	58	TC	42.3	42.3	48.5	39.0	39.0	44.9	35.5	35.5	41.2	32.0	32.0	37.4	
			SHC	36.0	42.3	48.5	33.0	39.0	44.9	29.8	35.5	41.2	26.6	32.0	37.4	
		62	TC	46.1	46.1	46.1	42.1	42.1	42.7	37.8	37.8	40.0	33.4	33.4	37.2	
			SHC	32.1	38.7	45.3	29.5	36.1	42.7	26.8	33.4	40.0	24.1	30.7	37.2	
		67	TC	52.6	52.6	52.6	48.4	48.4	48.4	43.9	43.9	43.9	39.3	39.3	39.3	
			SHC	26.7	33.3	39.8	24.0	30.6	37.2	21.4	28.0	34.6	18.6	25.2	31.8	
	72	TC	59.8	59.8	59.8	55.3	55.3	55.3	50.6	50.6	50.6	45.7	45.7	45.7		
		SHC	21.1	27.7	34.3	18.5	25.1	31.7	15.8	22.4	29.0	13.1	19.7	26.3		
	76	TC	—	66.0	66.0	—	61.3	61.3	—	56.4	56.4	—	51.2	51.2		
		SHC	—	23.1	29.7	—	20.5	27.1	—	17.9	24.5	—	15.2	21.8		
	1400 cfm	EA (wb)	58	TC	45.9	45.9	52.5	42.4	42.4	48.8	38.8	38.8	44.8	35.0	35.0	40.7
				SHC	39.2	45.9	52.5	36.0	42.4	48.8	32.7	38.8	44.8	29.2	35.0	40.7
62			TC	48.4	48.4	50.9	44.1	44.1	48.2	39.7	39.7	45.5	35.1	35.1	42.6	
			SHC	35.6	43.3	50.9	32.9	40.6	48.2	30.2	37.8	45.5	27.3	35.0	42.6	
67			TC	55.1	55.1	55.1	50.6	50.6	50.6	45.9	45.9	45.9	41.0	41.0	41.0	
			SHC	29.0	36.7	44.4	26.4	34.0	41.7	23.6	31.3	39.0	20.8	28.5	36.1	
72		TC	62.4	62.4	62.4	57.7	57.7	57.7	52.8	52.8	52.8	47.6	47.6	47.6		
		SHC	22.3	30.0	37.7	19.7	27.4	35.1	16.9	24.6	32.3	14.2	21.9	29.6		
76		TC	—	68.7	68.7	—	63.8	63.8	—	58.6	58.6	—	53.1	53.1		
		SHC	—	24.5	32.2	—	21.9	29.6	—	19.2	26.9	—	16.4	24.0		
1600 cfm		EA (wb)	58	TC	49.0	49.0	56.0	45.3	45.3	52.0	41.5	41.5	47.9	37.5	37.5	43.6
				SHC	42.0	49.0	56.0	38.6	45.3	52	35.1	41.5	47.9	31.5	37.5	43.6
	62		TC	50.2	50.2	56.4	45.9	45.9	53.6	41.4	41.4	50.0	37.6	37.6	45.7	
			SHC	38.9	47.7	56.4	36.2	44.9	53.6	32.8	41.4	50.0	29.6	37.6	45.7	
	67		TC	57.0	57.0	57.0	52.3	52.3	52.3	47.4	47.4	47.4	42.4	42.4	42.4	
			SHC	31.2	40.0	48.8	28.5	37.3	46.0	25.7	34.5	43.3	22.9	31.6	40.4	
	72	TC	64.5	64.5	64.5	59.6	59.6	59.6	54.4	54.4	54.4	49.1	49.1	49.1		
		SHC	23.4	32.2	40.9	20.7	29.5	38.3	17.9	26.7	35.5	15.1	23.9	32.7		
	76	TC	—	70.8	70.8	—	65.6	65.6	—	60.2	60.2	—	54.3	54.3		
		SHC	—	25.8	34.6	—	23.0	31.7	—	20.3	29.1	—	17.4	26.2		
	1800 cfm	EA (wb)	58	TC	51.7	51.7	59.0	47.9	47.9	54.9	43.9	43.9	50.6	39.8	39.8	46.0
				SHC	44.4	51.7	59.0	40.9	47.9	54.9	37.3	43.9	50.6	33.5	39.8	46.0
62			TC	51.9	51.9	61.4	48.0	48.0	57.3	44.0	44.0	52.9	39.8	39.8	48.2	
			SHC	42.0	51.7	61.4	38.7	48.0	57.3	35.1	44.0	52.9	31.5	39.8	48.2	
67			TC	58.5	58.5	58.5	53.7	53.7	53.7	48.7	48.7	48.7	43.5	43.5	44.5	
			SHC	33.3	43.2	53.0	30.6	40.4	50.2	27.7	37.6	47.4	24.9	34.7	44.5	
72		TC	66.1	66.1	66.1	61.0	61.0	61.0	55.8	55.8	55.8	50.2	50.2	50.2		
		SHC	24.3	34.2	44.1	21.6	31.5	41.4	18.8	28.7	38.6	15.9	25.8	35.7		
76		TC	—	72.3	72.3	—	66.9	66.9	—	61.2	61.2	—	55.2	55.2		
		SHC	—	26.8	36.7	—	24.1	34.0	—	21.2	31.1	—	18.3	28.1		
2000 cfm		EA (wb)	58	TC	54.1	54.1	61.7	50.1	50.1	57.4	46.0	46.0	52.9	41.7	41.7	48.2
				SHC	46.5	54.1	61.7	42.9	50.1	57.4	39.1	46.0	52.9	35.2	41.7	48.2
	62		TC	54.2	54.2	64.3	50.2	50.2	59.9	46.1	46.1	55.3	41.8	41.8	50.4	
			SHC	44.1	54.2	64.3	40.6	50.2	59.9	36.9	46.1	55.3	33.1	41.8	50.4	
	67		TC	59.7	59.7	59.7	54.9	54.9	54.9	49.7	49.7	51.5	44.4	44.4	48.6	
			SHC	35.3	46.2	57.1	32.5	43.4	54.3	29.7	40.6	51.5	26.8	37.7	48.6	
	72	TC	67.4	67.4	67.4	62.2	62.2	62.2	56.8	56.8	56.8	51.1	51.1	51.1		
		SHC	25.2	36.2	47.1	22.4	33.4	44.3	19.6	30.5	41.5	16.7	27.6	38.6		
	76	TC	—	73.5	73.5	—	67.9	67.9	—	62.0	62.0	—	55.7	55.7		
		SHC	—	27.8	38.8	—	25.0	35.9	—	22.1	32.9	—	19.0	29.7		

NOTE(S):

- a. See minimum-maximum airflow ratings on page 9.
- b. Published capacity values are based on SEER2 static requirements.

LEGEND

- Do Not Operate
- cfm — Cubic Feet Per Minute (Supply Air)
- EA (db) — Entering Air Temperature (dry bulb)
- EA (wb) — Entering Air Temperature (wet bulb)
- SHC — Sensible Heat Capacity (1000 Btuh) Gross
- TC — Total Capacity (1000 Btuh) Gross

48/50FE*N07 — Unit with Humidi-MiZer® System in Subcooling Mode — Cooling Capacities^a

TEMP (°F) AIR ENTERING CONDENSER (Edb)		AIR ENTERING EVAPORATOR — SCFM/BF								
		1800 / 0.06			2400 / 0.08			3000 / 0.10		
		Air Entering Evaporator — Ewb (°F)								
		72	67	62	72	67	62	72	67	62
75	TC	78.38	69.20	64.70	84.37	76.99	72.48	84.15	76.56	72.44
	SHC	31.20	38.91	35.62	39.12	49.13	45.87	40.04	52.20	48.52
	kW	5.34	5.27	5.12	5.27	5.31	5.26	5.40	5.33	5.18
85	TC	70.75	64.04	61.40	78.33	71.48	62.50	78.08	70.90	68.77
	SHC	26.19	34.36	38.96	33.55	44.10	43.76	34.31	46.89	53.73
	kW	5.80	5.74	3.07	5.74	5.77	3.13	5.85	5.79	3.10
95	TC	58.10	58.24	52.09	65.01	65.29	58.92	64.16	64.46	58.39
	SHC	30.14	29.73	39.29	38.76	39.01	50.96	40.56	41.43	54.99
	kW	6.32	6.29	6.05	6.27	6.32	6.16	6.37	6.33	6.10
105	TC	52.78	52.83	48.51	64.24	58.04	52.51	58.24	58.51	54.42
	SHC	23.95	25.27	40.72	24.42	35.64	46.60	33.40	36.23	57.94
	kW	6.86	6.84	3.51	5.39	5.42	5.45	6.91	6.88	3.54
115	TC	51.38	45.80	40.82	57.85	52.10	46.95	56.72	50.77	45.78
	SHC	10.12	19.38	28.51	15.80	27.48	38.79	14.99	28.88	41.93
	kW	7.63	7.58	7.54	7.58	7.61	7.64	7.67	7.62	7.59

NOTE(S):

a. Published capacity values are based on SEER2 static requirements.

48/50FE*N07 — Unit with Humidi-MiZer System in Hot Gas Reheat Mode — Cooling Capacities^a

TEMP (°F) AIR ENTERING CONDENSER (Edb)		AIR ENTERING EVAPORATOR — Ewb (°F)								
		75 Dry Bulb 62.5 Wet Bulb (50% Relative)			75 Dry Bulb 64 Wet Bulb (56% Relative)			75 Dry Bulb 65.3 Wet Bulb (60% Relative)		
		Air Entering Evaporator — Cfm								
		1800	2400	3000	1800	2400	3000	1800	2400	3000
80	TC	13.04	12.51	10.87	11.79	12.79	13.41	13.59	13.06	11.42
	SHC	3.02	3.70	3.55	-0.94	1.11	3.46	-0.98	-1.08	-2.01
	kW	5.17	5.50	6.13	5.57	5.58	5.58	5.32	5.64	6.26
75	TC	13.32	14.39	15.02	16.59	17.66	18.30	19.83	20.92	21.56
	SHC	1.60	4.23	7.07	5.19	7.29	9.64	8.70	10.34	12.28
	kW	5.29	5.31	5.31	5.26	5.27	5.28	5.23	5.24	5.25
70	TC	16.08	17.39	18.15	17.48	18.68	19.47	18.06	19.35	20.25
	SHC	-2.10	0.78	3.76	4.35	6.58	9.09	-4.80	-2.93	-0.74
	kW	4.00	3.95	3.93	5.06	5.05	5.03	3.87	3.83	3.81
60	TC	16.65	17.59	18.14	18.76	19.70	20.27	18.85	18.74	19.66
	SHC	-1.57	0.94	3.71	3.89	5.87	8.16	-4.25	-3.72	-1.49
	kW	3.98	4.02	4.04	4.80	4.83	4.85	4.12	4.09	4.04
50	TC	16.68	17.50	17.99	19.90	20.72	21.79	18.28	19.70	20.21
	SHC	-1.57	0.83	3.54	3.29	5.17	7.96	-4.79	-2.79	-0.97
	kW	4.07	4.12	4.16	4.56	4.61	4.54	4.06	4.00	4.03
40	TC	17.38	18.17	18.80	22.46	21.75	19.35	19.12	20.68	21.17
	SHC	-0.89	1.47	3.06	5.69	4.46	2.54	-3.97	-1.81	-0.02
	kW	4.01	4.08	4.13	3.96	4.39	4.92	3.98	3.92	3.95

NOTE(S):

a. Published capacity values are based on SEER2 static requirements.

LEGEND

Ewb — Entering wet bulb
kW — compressor Power Input
SCFM/BF — Standard Cubic Feet per Minute/Bypass Factor
SHC — Sensible Heat Capacity (1000 Btuh) Gross
TC — Total Capacity (1000 Btuh) Gross

Pressure Drops for Electric and Gas Heating Units

Pressure Drop for Electric Heat 3 Ton Units — 1 Stage Heat

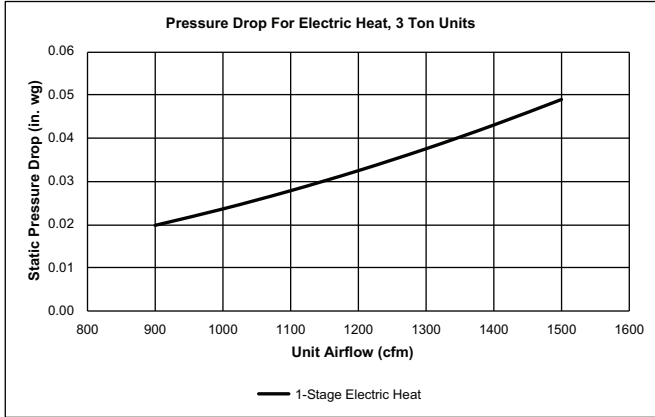

Pressure Drop for Electric Heat 4 to 6 Ton Units — 1 and 2 Stage Heat

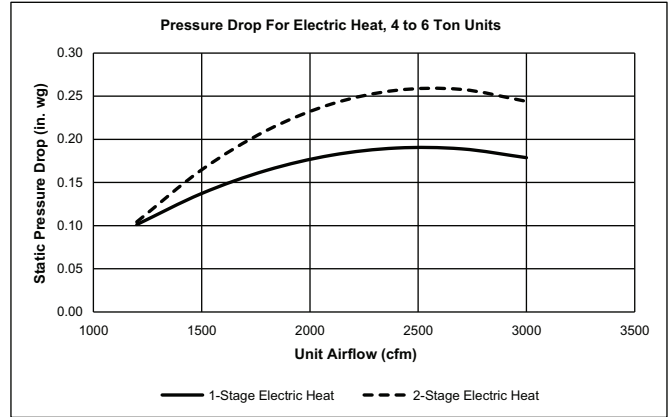

Pressure Drops across Gas Heat Exchanger for 48FE Ultra Low NOx 3 to 5 Ton Units

Pressure Drop across Gas Heat Exchanger, 48FE Ultra Low NOx — 3 Ton Units

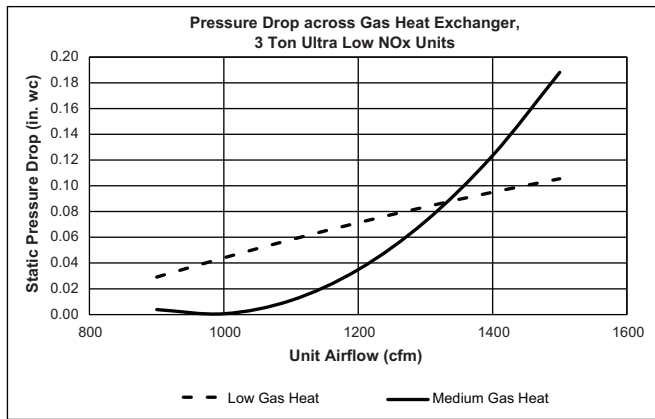

Pressure Drop across Gas Heat Exchanger, 48FE Ultra Low NOx — 4 to 5 Ton Units

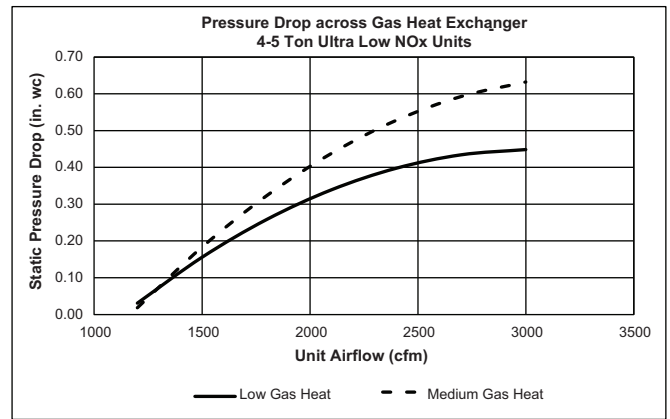

Single-Phase Gas Heat Stages

UNIT SIZE	HEAT SIZE			
	1 Phase	Low	Med	High
04		1	1	—
05		1	1	1
06		1	1	1

Three-Phase Gas Heat Stages

UNIT SIZE	HEAT SIZE			
	3 Phase	Low	Med	High
04		1	2	—
05		1	1	2
06		1	1	2
07		1	1	2

Gas Heat Stages for 48FE Ultra Low NO_x — 3-5 Ton Units

UNIT SIZE	HEAT SIZE	
	1-Phase or 3-Phase	Low or Medium
04		1
05		1
06		1

Gas Heat Static Pressure Deductions (in. wg) — 3 Ton Units

CFM	900	1000	1100	1200	1300	1400	1500
LOW GAS HEAT DEDUCTION	0.63	0.58	0.53	0.47	0.40	0.33	0.26
MEDIUM GAS HEAT DEDUCTION	0.01	0.01	0.02	0.03	0.03	0.04	0.04

Gas Heat Static Pressure Deductions (in. wg) — 4 to 6 Ton Units

CFM	1200	1500	1800	2100	2400	2700	3000
LOW GAS HEAT DEDUCTION	0.02	0.18	0.32	0.44	0.53	0.59	0.63
MEDIUM GAS HEAT DEDUCTION	0.03	0.10	0.17	0.23	0.29	0.36	0.42
HIGH GAS HEAT DEDUCTION	0.01	0.05	0.08	0.12	0.15	0.18	0.20

Gas Heat Static Pressure Deductions (in. wg) for 48FE Ultra Low NO_x — 3 Ton Units

CFM	900	1000	1100	1200	1300	1400	1500
LOW GAS HEAT DEDUCTION	0.63	0.58	0.53	0.47	0.40	0.33	0.26
MEDIUM GAS HEAT DEDUCTION	0.00	0.00	0.00	0.01	0.02	0.03	0.05

Gas Heat Static Pressure Deductions (in. wg) for 48FE Ultra Low NO_x — 4 to 5 Ton Units

CFM	1200	1500	1800	2100	2400	2700	3000
LOW GAS HEAT DEDUCTION	0.02	0.18	0.32	0.44	0.53	0.59	0.63
MEDIUM GAS HEAT DEDUCTION	0.01	0.05	0.08	0.12	0.15	0.18	0.20

50FE 04-07 Field-Installed Accessory Electric Heater Data

50FE UNIT SIZE	VOLTAGE	HEATER MODEL NUMBER ^a	NUMBER OF STAGES	
04	208/230	CRHEATER323A00	1	
		CRHEATER324A00	1	
		CRHEATER325A00	1	
		CRHEATER326A00	1	
		CRHEATER327A00	2	
		CRHEATER328A00	1	
	460	CRHEATER333A00	1	
		CRHEATER334A00	1	
		CRHEATER335A00	1	
		CRHEATER336A00	1	
		CRHEATER339A00	1	
		CRHEATER340A00	1	
05	208/230	CRHEATER323A00	1	
		CRHEATER324A00	1	
		CRHEATER325A00	1	
		CRHEATER327A00	2	
		CRHEATER328A00	1	
		CRHEATER329A00	2	
		CRHEATER330A00 ^b	2	
		CRHEATER331A00 ^c	2	
	460	CRHEATER333A00	1	
		CRHEATER335A00	1	
		CRHEATER336A00	1	
		CRHEATER337A00	2	
	575	CRHEATER339A00	1	
		CRHEATER340A00	1	
		CRHEATER324A00	1	
		CRHEATER325A00	1	
		CRHEATER326A00	1	
		CRHEATER327A00	2	
06	208/230	CRHEATER328A00	1	
		CRHEATER329A00	2	
		CRHEATER331A00	2	
		CRHEATER332A00	2	
		CRHEATER333A00	1	
		CRHEATER335A00	1	
		CRHEATER336A00	1	
		CRHEATER337A00	2	
	460	CRHEATER338A00	2	
		CRHEATER340A00	1	
		CRHEATER341A00	2	
		CRHEATER324A00	1	
	07	208/230	CRHEATER326A00	1
			CRHEATER328A00	1
			CRHEATER331A00	2
			CRHEATER332A00	2
			CRHEATER333A00	1
			CRHEATER335A00	1
460		CRHEATER336A00	1	
		CRHEATER337A00	2	
		CRHEATER338A00	2	
		CRHEATER340A00	1	
		CRHEATER341A00	2	
		CRHEATER341A00	2	

NOTE(S):

- a. Check heater nameplate for model number.
- b. Do not use with size 05 horizontal supply duct configuration units.
- c. Do not use with size 05 vertical supply duct configuration units.

Economizer Barometric Relief and Static Pressure

Horizontal Economizer Barometric Relief

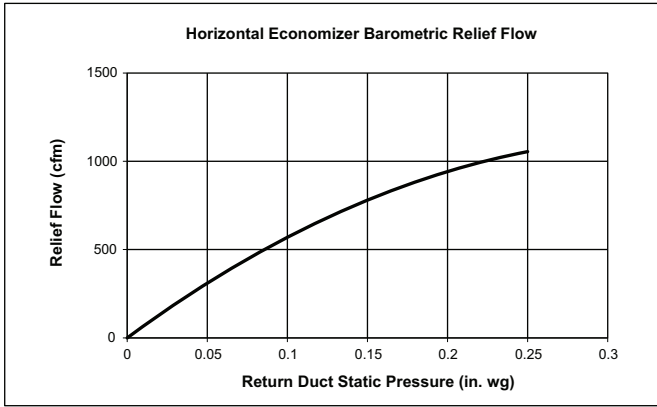

Vertical Economizer Barometric Relief

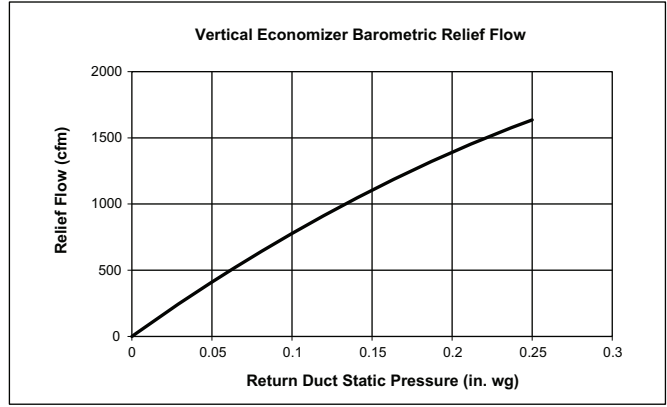

Horizontal Economizer Damper Leakage

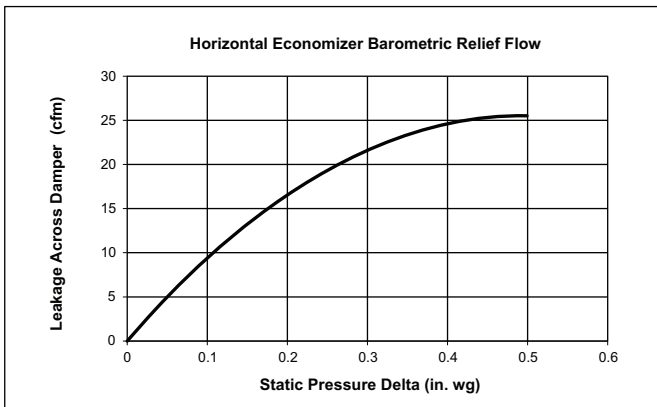

Vertical Economizer Damper Leakage

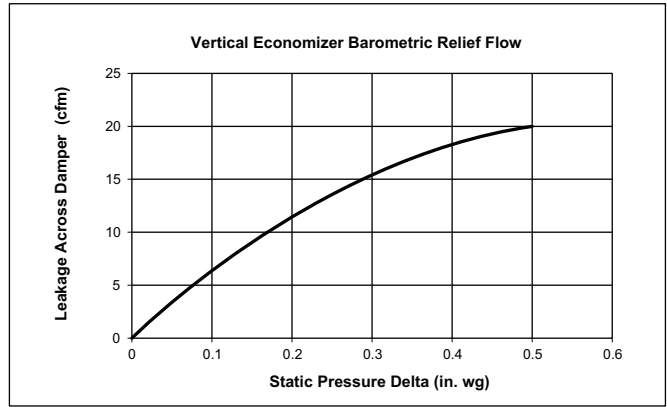

Humidi-MiZer® Coil Pressure Drops

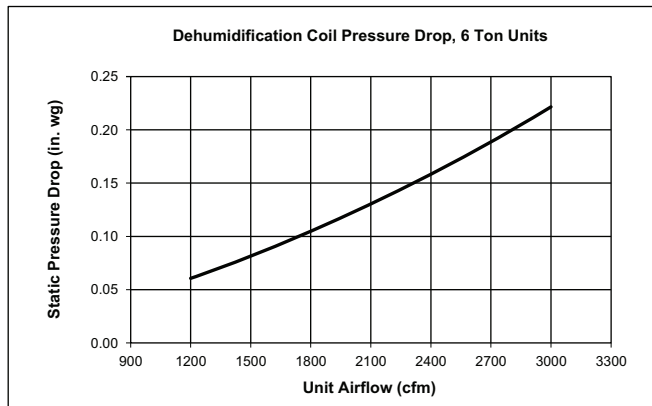
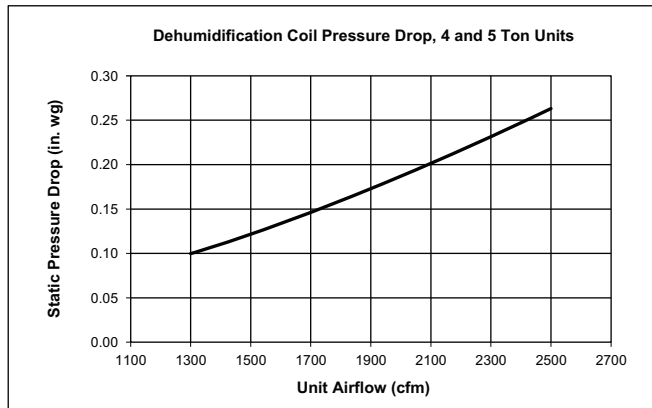
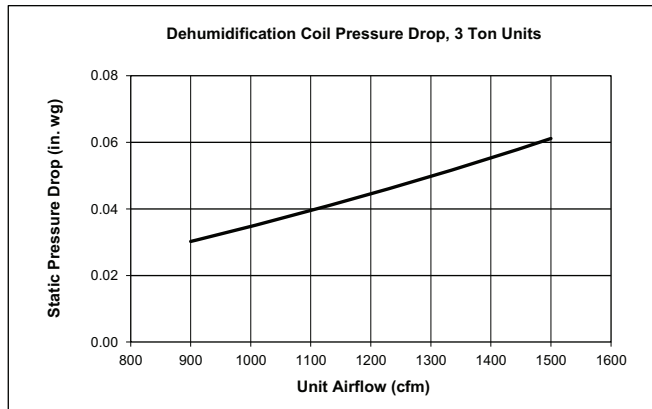

MERV-13 filters pressure drop

NOTE: For factory-installed MERV-13 filters, no additional pressure drop adjustments are necessary. The standard fan tables accommodate usage.

General Fan Performance Notes

1. Interpolation is permissible. Do not extrapolate.
2. External static pressure is the static pressure difference between the return duct and the supply duct plus the static pressure caused by any FIOPs or accessories.
3. Tabular data accounts for pressure loss due to clean filters, unit casing, wet coils, and highest gas heat exchanger (when gas heat unit).
4. Factory options and accessories may effect static pressure losses. Gas heat unit fan tables assume highest gas heat models; for fan selections with low or medium heat models, the user must deduct low and medium heat static pressures. Selection software is available, through your salesperson, to help you select the best motor/drive combination for your application.
5. The fan performance tables offer motor/drive recommendations. In cases when 2 motor/drive combinations would work, Carrier recommends the lower horsepower option.
6. Fan tables for 48FE units include highest gas heat. Utilize static pressure deduction tables on page 40 for lower gas heat capacities.
7. For information on the electrical properties of Carrier motors, please see the Electrical information section of this book.
8. For more information on the performance limits of Carrier motors, see the application data section of this book.
9. The EPACT (Energy Policy Act of 1992) regulates energy requirements for specific types of indoor fan motors. Motors regulated by EPACT include any general purpose, T-frame (3-digit, 143 and larger), single-speed, foot mounted, polyphase, squirrel cage induction motors of NEMA (National Electrical Manufacturers Association) design A and B, manufactured for use in the United States. Ranging from 1 to 200 Hp, these continuous-duty motors operate on 230 and 460 volt, 60 Hz power. If a motor does not fit into these specifications, the motor does not have to be replaced by an EPACT compliant energy-efficient motor. Variable-speed motors are exempt from EPACT compliance requirements.

48FEEA04 Single Phase — 3 Ton Vertical Supply (rpm - bhp)

CFM	AVAILABLE EXTERNAL STATIC PRESSURE (in. wg)									
	0.2		0.4		0.6		0.8		1.0	
	rpm	bhp	rpm	bhp	rpm	bhp	rpm	bhp	rpm	bhp
900	1112	0.10	1341	0.17	1530	0.25	1696	0.34	1845	0.44
975	1162	0.11	1385	0.19	1571	0.27	1733	0.36	1881	0.46
1050	1213	0.12	1431	0.20	1613	0.29	1772	0.39	1917	0.49
1125	1265	0.14	1477	0.22	1656	0.32	1813	0.41	1956	0.52
1200	1319	0.16	1525	0.25	1700	0.34	1855	0.44	1996	0.55
1275	1374	0.18	1573	0.27	1746	0.37	1898	0.48	2037	0.59
1350	1430	0.20	1623	0.30	1792	0.40	1942	0.51	2079	0.63
1425	1487	0.23	1674	0.33	1839	0.43	1987	0.55	2122	0.67
1500	1545	0.26	1725	0.36	1887	0.47	2032	0.58	2165	0.71

CFM	AVAILABLE EXTERNAL STATIC PRESSURE (in. wg)									
	1.2		1.4		1.6		1.8		2.0	
	rpm	bhp	rpm	bhp	rpm	bhp	rpm	bhp	rpm	bhp
900	1983	0.54	2111	0.66	2231	0.77	2344	0.90	2452	1.03
975	2016	0.57	2143	0.69	2262	0.81	2375	0.93	2482	1.06
1050	2051	0.60	2177	0.72	2294	0.84	2406	0.97	—	—
1125	2088	0.63	2211	0.75	2328	0.88	2438	1.01	—	—
1200	2126	0.67	2248	0.79	2363	0.92	2472	1.05	—	—
1275	2165	0.71	2285	0.83	2399	0.96	—	—	—	—
1350	2205	0.75	2324	0.87	2437	1.01	—	—	—	—
1425	2247	0.79	2364	0.92	2475	1.06	—	—	—	—
1500	2289	0.84	2405	0.97	—	—	—	—	—	—

Standard/Medium Static 1112-2190 rpm, 0.71 maximum bhp

High Static 1112-2490 rpm, 1.07 maximum bhp

48FEEA04 Single Phase — Standard/Medium Static — 3 Ton Vertical Supply (rpm - vdc)

CFM	AVAILABLE EXTERNAL STATIC PRESSURE (in. wg)									
	0.2		0.4		0.6		0.8		1.0	
	rpm	vdc	rpm	vdc	rpm	vdc	rpm	vdc	rpm	vdc
900	1112	5.1	1341	6.1	1530	7.0	1696	7.7	1845	8.4
975	1162	5.3	1385	6.3	1571	7.2	1733	7.9	1881	8.6
1050	1213	5.5	1431	6.5	1613	7.4	1772	8.1	1917	8.8
1125	1265	5.8	1477	6.7	1656	7.6	1813	8.3	1956	8.9
1200	1319	6.0	1525	7.0	1700	7.8	1855	8.5	1996	9.1
1275	1374	6.3	1573	7.2	1746	8.0	1898	8.7	2037	9.3
1350	1430	6.5	1623	7.4	1792	8.2	1942	8.9	2079	9.5
1425	1487	6.8	1674	7.6	1839	8.4	1987	9.1	2122	9.7
1500	1545	7.1	1725	7.9	1887	8.6	2032	9.3	2165	9.9

CFM	AVAILABLE EXTERNAL STATIC PRESSURE (in. wg)									
	1.2		1.4		1.6		1.8		2.0	
	rpm	vdc	rpm	vdc	rpm	vdc	rpm	vdc	rpm	vdc
900	1983	9.1	2111	9.6	—	—	—	—	—	—
975	2016	9.2	2143	9.8	—	—	—	—	—	—
1050	2051	9.4	—	—	—	—	—	—	—	—
1125	2088	9.5	—	—	—	—	—	—	—	—
1200	2126	9.7	—	—	—	—	—	—	—	—
1275	2165	9.9	—	—	—	—	—	—	—	—
1350	—	—	—	—	—	—	—	—	—	—
1425	—	—	—	—	—	—	—	—	—	—
1500	—	—	—	—	—	—	—	—	—	—

Standard/Medium Static 1112-2190 rpm

48FEEA04 Single Phase — High Static — 3 Ton Vertical Supply (rpm - vdc)

CFM	AVAILABLE EXTERNAL STATIC PRESSURE (in. wg)									
	0.2		0.4		0.6		0.8		1.0	
	rpm	vdc	rpm	vdc	rpm	vdc	rpm	vdc	rpm	vdc
900	1112	4.5	1341	5.4	1530	6.1	1696	6.8	1845	7.4
975	1162	4.7	1385	5.6	1571	6.3	1733	7.0	1881	7.6
1050	1213	4.9	1431	5.7	1613	6.5	1772	7.1	1917	7.7
1125	1265	5.1	1477	5.9	1656	6.7	1813	7.3	1956	7.9
1200	1319	5.3	1525	6.1	1700	6.8	1855	7.4	1996	8.0
1275	1374	5.5	1573	6.3	1746	7.0	1898	7.6	2037	8.2
1350	1430	5.7	1623	6.5	1792	7.2	1942	7.8	2079	8.3
1425	1487	6.0	1674	6.7	1839	7.4	1987	8.0	2122	8.5
1500	1545	6.2	1725	6.9	1887	7.6	2032	8.2	2165	8.7

CFM	AVAILABLE EXTERNAL STATIC PRESSURE (in. wg)									
	1.2		1.4		1.6		1.8		2.0	
	rpm	vdc	rpm	vdc	rpm	vdc	rpm	vdc	rpm	vdc
900	1983	8.0	2111	8.5	2231	9.0	2344	9.4	2452	9.8
975	2016	8.1	2143	8.6	2262	9.1	2375	9.5	2482	10.0
1050	2051	8.2	2177	8.7	2294	9.2	2406	9.7	—	—
1125	2088	8.4	2211	8.9	2328	9.3	2438	9.8	—	—
1200	2126	8.5	2248	9.0	2363	9.5	2472	9.9	—	—
1275	2165	8.7	2285	9.2	2399	9.6	—	—	—	—
1350	2205	8.9	2324	9.3	2437	9.8	—	—	—	—
1425	2247	9.0	2364	9.5	2475	9.9	—	—	—	—
1500	2289	9.2	2405	9.7	—	—	—	—	—	—

High Static 1112-2490 rpm

48FEEA04 Three Phase — 3 Ton Vertical Supply (rpm - bhp)

CFM	AVAILABLE EXTERNAL STATIC PRESSURE (in. wg)									
	0.2		0.4		0.6		0.8		1.0	
	rpm	bhp	rpm	bhp	rpm	bhp	rpm	bhp	rpm	bhp
900	1112	0.10	1341	0.17	1530	0.25	1696	0.34	1845	0.44
975	1162	0.11	1385	0.19	1571	0.27	1733	0.36	1881	0.46
1050	1213	0.12	1431	0.20	1613	0.29	1772	0.39	1917	0.49
1125	1265	0.14	1477	0.22	1656	0.32	1813	0.41	1956	0.52
1200	1319	0.16	1525	0.25	1700	0.34	1855	0.44	1996	0.55
1275	1374	0.18	1573	0.27	1746	0.37	1898	0.48	2037	0.59
1350	1430	0.20	1623	0.30	1792	0.40	1942	0.51	2079	0.63
1425	1487	0.23	1674	0.33	1839	0.43	1987	0.55	2122	0.67
1500	1545	0.26	1725	0.36	1887	0.47	2032	0.58	2165	0.71

CFM	AVAILABLE EXTERNAL STATIC PRESSURE (in. wg)									
	1.2		1.4		1.6		1.8		2.0	
	rpm	bhp	rpm	bhp	rpm	bhp	rpm	bhp	rpm	bhp
900	1983	0.54	2111	0.66	2231	0.77	2344	0.90	2452	1.03
975	2016	0.57	2143	0.69	2262	0.81	2375	0.93	2482	1.06
1050	2051	0.60	2177	0.72	2294	0.84	2406	0.97	—	—
1125	2088	0.63	2211	0.75	2328	0.88	2438	1.01	—	—
1200	2126	0.67	2248	0.79	2363	0.92	2472	1.05	—	—
1275	2165	0.71	2285	0.83	2399	0.96	—	—	—	—
1350	2205	0.75	2324	0.87	2437	1.01	—	—	—	—
1425	2247	0.79	2364	0.92	2475	1.06	—	—	—	—
1500	2289	0.84	2405	0.97	—	—	—	—	—	—

Standard/Medium Static 1112-2190 rpm, 0.71 maximum bhp

High Static 1112-2490 rpm, 1.07 maximum bhp

48FEEA04 Three Phase — Standard/Medium Static — 3 Ton Vertical Supply (rpm - vdc)

CFM	AVAILABLE EXTERNAL STATIC PRESSURE (in. wg)									
	0.2		0.4		0.6		0.8		1.0	
	rpm	vdc	rpm	vdc	rpm	vdc	rpm	vdc	rpm	vdc
900	1112	5.1	1341	6.1	1530	7.0	1696	7.7	1845	8.4
975	1162	5.3	1385	6.3	1571	7.2	1733	7.9	1881	8.6
1050	1213	5.5	1431	6.5	1613	7.4	1772	8.1	1917	8.8
1125	1265	5.8	1477	6.7	1656	7.6	1813	8.3	1956	8.9
1200	1319	6.0	1525	7.0	1700	7.8	1855	8.5	1996	9.1
1275	1374	6.3	1573	7.2	1746	8.0	1898	8.7	2037	9.3
1350	1430	6.5	1623	7.4	1792	8.2	1942	8.9	2079	9.5
1425	1487	6.8	1674	7.6	1839	8.4	1987	9.1	2122	9.7
1500	1545	7.1	1725	7.9	1887	8.6	2032	9.3	2165	9.9

CFM	AVAILABLE EXTERNAL STATIC PRESSURE (in. wg)									
	1.2		1.4		1.6		1.8		2.0	
	rpm	vdc	rpm	vdc	rpm	vdc	rpm	vdc	rpm	vdc
900	1983	9.1	2111	9.6	—	—	—	—	—	—
975	2016	9.2	2143	9.8	—	—	—	—	—	—
1050	2051	9.4	—	—	—	—	—	—	—	—
1125	2088	9.5	—	—	—	—	—	—	—	—
1200	2126	9.7	—	—	—	—	—	—	—	—
1275	2165	9.9	—	—	—	—	—	—	—	—
1350	—	—	—	—	—	—	—	—	—	—
1425	—	—	—	—	—	—	—	—	—	—
1500	—	—	—	—	—	—	—	—	—	—

Standard/Medium Static 1112-2190 rpm

48FEEA04 Three Phase — High Static — 3 Ton Vertical Supply (rpm - vdc)

CFM	AVAILABLE EXTERNAL STATIC PRESSURE (in. wg)									
	0.2		0.4		0.6		0.8		1.0	
	rpm	vdc	rpm	vdc	rpm	vdc	rpm	vdc	rpm	vdc
900	1112	4.5	1341	5.4	1530	6.1	1696	6.8	1845	7.4
975	1162	4.7	1385	5.6	1571	6.3	1733	7.0	1881	7.6
1050	1213	4.9	1431	5.7	1613	6.5	1772	7.1	1917	7.7
1125	1265	5.1	1477	5.9	1656	6.7	1813	7.3	1956	7.9
1200	1319	5.3	1525	6.1	1700	6.8	1855	7.4	1996	8.0
1275	1374	5.5	1573	6.3	1746	7.0	1898	7.6	2037	8.2
1350	1430	5.7	1623	6.5	1792	7.2	1942	7.8	2079	8.3
1425	1487	6.0	1674	6.7	1839	7.4	1987	8.0	2122	8.5
1500	1545	6.2	1725	6.9	1887	7.6	2032	8.2	2165	8.7

CFM	AVAILABLE EXTERNAL STATIC PRESSURE (in. wg)									
	1.2		1.4		1.6		1.8		2.0	
	rpm	vdc	rpm	vdc	rpm	vdc	rpm	vdc	rpm	vdc
900	1983	8.0	2111	8.5	2231	9.0	2344	9.4	2452	9.8
975	2016	8.1	2143	8.6	2262	9.1	2375	9.5	2482	10.0
1050	2051	8.2	2177	8.7	2294	9.2	2406	9.7	—	—
1125	2088	8.4	2211	8.9	2328	9.3	2438	9.8	—	—
1200	2126	8.5	2248	9.0	2363	9.5	2472	9.9	—	—
1275	2165	8.7	2285	9.2	2399	9.6	—	—	—	—
1350	2205	8.9	2324	9.3	2437	9.8	—	—	—	—
1425	2247	9.0	2364	9.5	2475	9.9	—	—	—	—
1500	2289	9.2	2405	9.7	—	—	—	—	—	—

High Static 1112-2490 rpm

48FEFA05 Single Phase — 4 Ton Vertical Supply (rpm - bhp)

CFM	AVAILABLE EXTERNAL STATIC PRESSURE (in. wg)									
	0.2		0.4		0.6		0.8		1.0	
	rpm	bhp	rpm	bhp	rpm	bhp	rpm	bhp	rpm	bhp
1200	1262	0.21	1452	0.33	1614	0.45	1757	0.58	1888	0.72
1300	1333	0.25	1516	0.37	1674	0.50	1813	0.63	1942	0.78
1400	1405	0.29	1583	0.42	1735	0.55	1872	0.70	1997	0.84
1500	1478	0.34	1650	0.48	1798	0.62	1932	0.76	2054	0.92
1600	1552	0.40	1718	0.54	1863	0.68	1993	0.84	2114	1.00
1700	1627	0.46	1787	0.60	1928	0.76	2057	0.92	2174	1.09
1800	1704	0.52	1857	0.68	1995	0.84	2121	1.01	2236	1.18
1900	1781	0.60	1929	0.76	2063	0.93	2185	1.10	2299	1.28
2000	1859	0.68	2001	0.85	2132	1.02	2252	1.21	2363	1.39

CFM	AVAILABLE EXTERNAL STATIC PRESSURE (in. wg)									
	1.2		1.4		1.6		1.8		2.0	
	rpm	bhp	rpm	bhp	rpm	bhp	rpm	bhp	rpm	bhp
1200	2011	0.87	2126	1.02	2236	1.19	2341	1.37	2442	1.55
1300	2061	0.93	2174	1.09	2281	1.26	2384	1.44	—	—
1400	2114	1.00	2224	1.17	2329	1.34	2429	1.52	—	—
1500	2169	1.08	2277	1.25	2379	1.43	—	—	—	—
1600	2226	1.17	2331	1.34	2432	1.52	—	—	—	—
1700	2284	1.26	2388	1.44	—	—	—	—	—	—
1800	2344	1.36	2446	1.55	—	—	—	—	—	—
1900	2405	1.47	—	—	—	—	—	—	—	—
2000	—	—	—	—	—	—	—	—	—	—

Standard/Medium Static 1262-2170 rpm, 1.06 maximum bhp

High Static 1262-2460 rpm, 1.53 maximum bhp

48FEFA05 Single Phase — Standard/Medium Static — 4 Ton Vertical Supply (rpm - vdc)

CFM	AVAILABLE EXTERNAL STATIC PRESSURE (in. wg)									
	0.2		0.4		0.6		0.8		1.0	
	rpm	vdc	rpm	vdc	rpm	vdc	rpm	vdc	rpm	vdc
1200	1262	5.8	1452	6.7	1614	7.4	1757	8.1	1888	8.7
1300	1333	6.1	1516	7.0	1674	7.7	1813	8.4	1942	8.9
1400	1405	6.5	1583	7.3	1735	8.0	1872	8.6	1997	9.2
1500	1478	6.8	1650	7.6	1798	8.3	1932	8.9	2054	9.5
1600	1552	7.2	1718	7.9	1863	8.6	1993	9.2	2114	9.7
1700	1627	7.5	1787	8.2	1928	8.9	2057	9.5	—	—
1800	1704	7.9	1857	8.6	1995	9.2	2121	9.8	—	—
1900	1781	8.2	1929	8.9	2063	9.5	—	—	—	—
2000	1859	8.6	2001	9.2	2132	9.8	—	—	—	—

CFM	AVAILABLE EXTERNAL STATIC PRESSURE (in. wg)									
	1.2		1.4		1.6		1.8		2.0	
	rpm	vdc	rpm	vdc	rpm	vdc	rpm	vdc	rpm	vdc
1200	2011	9.3	2126	9.8	—	—	—	—	—	—
1300	2061	9.5	—	—	—	—	—	—	—	—
1400	2114	9.7	—	—	—	—	—	—	—	—
1500	—	—	—	—	—	—	—	—	—	—
1600	—	—	—	—	—	—	—	—	—	—
1700	—	—	—	—	—	—	—	—	—	—
1800	—	—	—	—	—	—	—	—	—	—
1900	—	—	—	—	—	—	—	—	—	—
2000	—	—	—	—	—	—	—	—	—	—

Standard/Medium Static 1262-2170 rpm

48FEFA05 Single Phase — High Static — 4 Ton Vertical Supply (rpm - vdc)

CFM	AVAILABLE EXTERNAL STATIC PRESSURE (in. wg)									
	0.2		0.4		0.6		0.8		1.0	
	rpm	vdc	rpm	vdc	rpm	vdc	rpm	vdc	rpm	vdc
1200	1262	5.1	1452	5.9	1614	6.6	1757	7.1	1888	7.7
1300	1333	5.4	1516	6.2	1674	6.8	1813	7.4	1942	7.9
1400	1405	5.7	1583	6.4	1735	7.1	1872	7.6	1997	8.1
1500	1478	6.0	1650	6.7	1798	7.3	1932	7.9	2054	8.3
1600	1552	6.3	1718	7.0	1863	7.6	1993	8.1	2114	8.6
1700	1627	6.6	1787	7.3	1928	7.8	2057	8.4	2174	8.8
1800	1704	6.9	1857	7.5	1995	8.1	2121	8.6	2236	9.1
1900	1781	7.2	1929	7.8	2063	8.4	2185	8.9	2299	9.3
2000	1859	7.6	2001	8.1	2132	8.7	2252	9.2	2363	9.6

CFM	AVAILABLE EXTERNAL STATIC PRESSURE (in. wg)									
	1.2		1.4		1.6		1.8		2.0	
	rpm	vdc	rpm	vdc	rpm	vdc	rpm	vdc	rpm	vdc
1200	2011	8.2	2126	8.6	2236	9.1	2341	9.5	2442	9.9
1300	2061	8.4	2174	8.8	2281	9.3	2384	9.7	—	—
1400	2114	8.6	2224	9.0	2329	9.5	2429	9.9	—	—
1500	2169	8.8	2277	9.3	2379	9.7	—	—	—	—
1600	2226	9.0	2331	9.5	2432	9.9	—	—	—	—
1700	2284	9.3	2388	9.7	—	—	—	—	—	—
1800	2344	9.5	2446	9.9	—	—	—	—	—	—
1900	2405	9.8	—	—	—	—	—	—	—	—
2000	—	—	—	—	—	—	—	—	—	—

High Static 1262-2460 rpm

48FEFA05 Three Phase — 4 Ton Vertical Supply (rpm - bhp)

CFM	AVAILABLE EXTERNAL STATIC PRESSURE (in. wg)									
	0.2		0.4		0.6		0.8		1.0	
	rpm	bhp	rpm	bhp	rpm	bhp	rpm	bhp	rpm	bhp
1200	1262	0.21	1453	0.33	1614	0.45	1757	0.58	1888	0.72
1300	1333	0.25	1517	0.37	1674	0.50	1814	0.63	1942	0.78
1400	1405	0.29	1583	0.42	1736	0.56	1872	0.70	1998	0.85
1500	1478	0.34	1650	0.48	1799	0.62	1932	0.76	2055	0.92
1600	1553	0.40	1718	0.54	1863	0.68	1994	0.84	2114	1.00
1700	1628	0.46	1787	0.60	1929	0.76	2057	0.92	2174	1.09
1800	1704	0.52	1858	0.68	1995	0.84	2121	1.01	2236	1.18
1900	1781	0.60	1929	0.76	2063	0.93	2186	1.10	2299	1.28
2000	1859	0.68	2001	0.85	2132	1.02	2252	1.21	2363	1.39

CFM	AVAILABLE EXTERNAL STATIC PRESSURE (in. wg)									
	1.2		1.4		1.6		1.8		2.0	
	rpm	bhp	rpm	bhp	rpm	bhp	rpm	bhp	rpm	bhp
1200	2011	0.87	2126	1.02	2236	1.19	2341	1.37	2442	1.55
1300	2061	0.93	2174	1.09	2281	1.26	2383	1.44	2482	1.62
1400	2114	1.00	2224	1.17	2329	1.34	2429	1.52	2526	1.71
1500	2169	1.08	2277	1.25	2379	1.43	2478	1.61	2572	1.80
1600	2226	1.17	2332	1.34	2432	1.52	2528	1.71	2621	1.91
1700	2284	1.26	2388	1.44	2487	1.63	2581	1.82	—	—
1800	2344	1.36	2446	1.55	2543	1.74	2636	1.94	—	—
1900	2405	1.47	2505	1.66	2600	1.86	—	—	—	—
2000	2467	1.59	2566	1.79	2659	1.99	—	—	—	—

Standard/Medium Static 1262-2170 rpm, 1.06 maximum bhp

High Static 1262-2660 rpm, 1.96 maximum bhp

48FEFA05 Three Phase — Standard/Medium Static — 4 Ton Vertical Supply (rpm - vdc)

CFM	AVAILABLE EXTERNAL STATIC PRESSURE (in. wg)									
	0.2		0.4		0.6		0.8		1.0	
	rpm	vdc	rpm	vdc	rpm	vdc	rpm	vdc	rpm	vdc
1200	1262	5.8	1453	6.7	1614	7.4	1757	8.1	1888	8.7
1300	1333	6.1	1517	7.0	1674	7.7	1814	8.4	1942	8.9
1400	1405	6.5	1583	7.3	1736	8.0	1872	8.6	1998	9.2
1500	1478	6.8	1650	7.6	1799	8.3	1932	8.9	2055	9.5
1600	1553	7.2	1718	7.9	1863	8.6	1994	9.2	2114	9.7
1700	1628	7.5	1787	8.2	1929	8.9	2057	9.5	—	—
1800	1704	7.9	1858	8.6	1995	9.2	2121	9.8	—	—
1900	1781	8.2	1929	8.9	2063	9.5	—	—	—	—
2000	1859	8.6	2001	9.2	2132	9.8	—	—	—	—

CFM	AVAILABLE EXTERNAL STATIC PRESSURE (in. wg)									
	1.2		1.4		1.6		1.8		2.0	
	rpm	vdc	rpm	vdc	rpm	vdc	rpm	vdc	rpm	vdc
1200	2011	9.3	2126	9.8	—	—	—	—	—	—
1300	2061	9.5	—	—	—	—	—	—	—	—
1400	2114	9.7	—	—	—	—	—	—	—	—
1500	—	—	—	—	—	—	—	—	—	—
1600	—	—	—	—	—	—	—	—	—	—
1700	—	—	—	—	—	—	—	—	—	—
1800	—	—	—	—	—	—	—	—	—	—
1900	—	—	—	—	—	—	—	—	—	—
2000	—	—	—	—	—	—	—	—	—	—

Standard/Medium Static 1262-2170 rpm

48FEFA05 Three Phase — High Static — 4 Ton Vertical Supply (rpm - vdc)

CFM	AVAILABLE EXTERNAL STATIC PRESSURE (in. wg)									
	0.2		0.4		0.6		0.8		1.0	
	rpm	vdc	rpm	vdc	rpm	vdc	rpm	vdc	rpm	vdc
1200	1262	4.7	1453	5.5	1614	6.1	1757	6.6	1888	7.1
1300	1333	5.0	1517	5.7	1674	6.3	1814	6.8	1942	7.3
1400	1405	5.3	1583	6.0	1736	6.5	1872	7.0	1998	7.5
1500	1478	5.6	1650	6.2	1799	6.8	1932	7.3	2055	7.7
1600	1553	5.8	1718	6.5	1863	7.0	1994	7.5	2114	7.9
1700	1628	6.1	1787	6.7	1929	7.3	2057	7.7	2174	8.2
1800	1704	6.4	1858	7.0	1995	7.5	2121	8.0	2236	8.4
1900	1781	6.7	1929	7.3	2063	7.8	2186	8.2	2299	8.6
2000	1859	7.0	2001	7.5	2132	8.0	2252	8.5	2363	8.9

CFM	AVAILABLE EXTERNAL STATIC PRESSURE (in. wg)									
	1.2		1.4		1.6		1.8		2.0	
	rpm	vdc	rpm	vdc	rpm	vdc	rpm	vdc	rpm	vdc
1200	2011	7.6	2126	8.0	2236	8.4	2341	8.8	2442	9.2
1300	2061	7.7	2174	8.2	2281	8.6	2383	9.0	2482	9.3
1400	2114	7.9	2224	8.4	2329	8.8	2429	9.1	2526	9.5
1500	2169	8.2	2277	8.6	2379	8.9	2478	9.3	2572	9.7
1600	2226	8.4	2332	8.8	2432	9.1	2528	9.5	2621	9.9
1700	2284	8.6	2388	9.0	2487	9.3	2581	9.7	—	—
1800	2344	8.8	2446	9.2	2543	9.6	2636	9.9	—	—
1900	2405	9.0	2505	9.4	2600	9.8	—	—	—	—
2000	2467	9.3	2566	9.6	2659	10.0	—	—	—	—

High Static 1262-2660 rpm

48FEFA06 Single Phase — 5 Ton Vertical Supply (rpm - bhp)

CFM	AVAILABLE EXTERNAL STATIC PRESSURE (in. wg)									
	0.2		0.4		0.6		0.8		1.0	
	rpm	bhp	rpm	bhp	rpm	bhp	rpm	bhp	rpm	bhp
1500	1478	0.34	1650	0.48	1799	0.62	1932	0.76	2054	0.92
1625	1571	0.41	1735	0.55	1879	0.70	2009	0.86	2129	1.02
1750	1666	0.49	1822	0.64	1962	0.80	2088	0.96	2205	1.13
1875	1762	0.58	1911	0.74	2046	0.91	2169	1.08	2283	1.26
2000	1859	0.68	2001	0.85	2132	1.02	2252	1.21	2363	1.39
2125	1957	0.79	2093	0.97	2218	1.15	2335	1.34	2444	1.54
2250	2056	0.92	2186	1.10	2307	1.30	2420	1.50	2527	1.70
2375	2156	1.06	2280	1.25	2396	1.45	2507	1.66	2611	1.88
2500	2256	1.21	2375	1.41	2487	1.62	2594	1.84	—	—

CFM	AVAILABLE EXTERNAL STATIC PRESSURE (in. wg)									
	1.2		1.4		1.6		1.8		2.0	
	rpm	bhp	rpm	bhp	rpm	bhp	rpm	bhp	rpm	bhp
1500	2169	1.08	2277	1.25	2379	1.43	2478	1.61	2572	1.80
1625	2240	1.19	2345	1.37	2445	1.55	2541	1.74	2634	1.93
1750	2314	1.31	2417	1.49	2514	1.68	2608	1.88	—	—
1875	2390	1.44	2490	1.63	2586	1.83	—	—	—	—
2000	2467	1.59	2566	1.79	2660	1.99	—	—	—	—
2125	2546	1.74	2643	1.95	—	—	—	—	—	—
2250	2627	1.91	—	—	—	—	—	—	—	—
2375	—	—	—	—	—	—	—	—	—	—
2500	—	—	—	—	—	—	—	—	—	—

Standard/Medium Static 1478-2390 rpm, 1.44 maximum bhp

High Static 1478-2660 rpm, 1.96 maximum bhp

48FEFA06 Single Phase — Standard/Medium Static — 5 Ton Vertical Supply (rpm - vdc)

CFM	AVAILABLE EXTERNAL STATIC PRESSURE (in. wg)									
	0.2		0.4		0.6		0.8		1.0	
	rpm	vdc	rpm	vdc	rpm	vdc	rpm	vdc	rpm	vdc
1500	1478	6.2	1650	6.9	1799	7.5	1932	8.1	2055	8.6
1625	1571	6.6	1735	7.3	1879	7.9	2009	8.4	2129	8.9
1750	1666	7.0	1822	7.6	1962	8.2	2088	8.7	2205	9.2
1875	1761	7.4	1910	8.0	2046	8.6	2169	9.1	2283	9.6
2000	1859	7.8	2001	8.4	2132	8.9	2252	9.4	2363	9.9
2125	1957	8.2	2093	8.8	2218	9.3	2335	9.8	—	—
2250	2056	8.6	2185	9.1	2307	9.7	—	—	—	—
2375	2155	9.0	2279	9.5	—	—	—	—	—	—
2500	2256	9.4	2374	9.9	—	—	—	—	—	—

CFM	AVAILABLE EXTERNAL STATIC PRESSURE (in. wg)									
	1.2		1.4		1.6		1.8		2.0	
	rpm	vdc	rpm	vdc	rpm	vdc	rpm	vdc	rpm	vdc
1500	2169	9.1	2277	9.5	2379	10.0	—	—	—	—
1625	2240	9.4	2345	9.8	—	—	—	—	—	—
1750	2314	9.7	—	—	—	—	—	—	—	—
1875	2389	10.0	—	—	—	—	—	—	—	—
2000	—	—	—	—	—	—	—	—	—	—
2125	—	—	—	—	—	—	—	—	—	—
2250	—	—	—	—	—	—	—	—	—	—
2375	—	—	—	—	—	—	—	—	—	—
2500	—	—	—	—	—	—	—	—	—	—

Standard/Medium Static 1478-2390 rpm

48FEFA06 Single Phase — High Static — 5 Ton Vertical Supply (rpm - vdc)

CFM	AVAILABLE EXTERNAL STATIC PRESSURE (in. wg)									
	0.2		0.4		0.6		0.8		1.0	
	rpm	vdc	rpm	vdc	rpm	vdc	rpm	vdc	rpm	vdc
1500	1478	5.6	1650	6.2	1799	6.8	1932	7.3	2054	7.7
1625	1571	5.9	1735	6.5	1879	7.1	2009	7.6	2129	8.0
1750	1666	6.3	1822	6.8	1962	7.4	2088	7.8	2205	8.3
1875	1762	6.6	1911	7.2	2046	7.7	2169	8.2	2283	8.6
2000	1859	7.0	2001	7.5	2132	8.0	2252	8.5	2363	8.9
2125	1957	7.4	2093	7.9	2218	8.3	2335	8.8	2444	9.2
2250	2056	7.7	2186	8.2	2307	8.7	2420	9.1	2527	9.5
2375	2156	8.1	2280	8.6	2396	9.0	2507	9.4	2611	9.8
2500	2256	8.5	2375	8.9	2487	9.3	2594	9.8	—	—

CFM	AVAILABLE EXTERNAL STATIC PRESSURE (in. wg)									
	1.2		1.4		1.6		1.8		2.0	
	rpm	vdc	rpm	vdc	rpm	vdc	rpm	vdc	rpm	vdc
1500	2169	8.2	2277	8.6	2379	8.9	2478	9.3	2572	9.7
1625	2240	8.4	2345	8.8	2445	9.2	2541	9.6	2634	9.9
1750	2314	8.7	2417	9.1	2514	9.5	2608	9.8	—	—
1875	2390	9.0	2490	9.4	2586	9.7	—	—	—	—
2000	2467	9.3	2566	9.6	2660	10.0	—	—	—	—
2125	2546	9.6	2643	9.9	—	—	—	—	—	—
2250	2627	9.9	—	—	—	—	—	—	—	—
2375	—	—	—	—	—	—	—	—	—	—
2500	—	—	—	—	—	—	—	—	—	—

High Static 1478-2660 rpm

48FEFA06 Three Phase — 5 Ton Vertical Supply (rpm - bhp)

CFM	AVAILABLE EXTERNAL STATIC PRESSURE (in. wg)									
	0.2		0.4		0.6		0.8		1.0	
	rpm	bhp	rpm	bhp	rpm	bhp	rpm	bhp	rpm	bhp
1500	1478	0.34	1650	0.48	1798	0.62	1932	0.76	2055	0.92
1625	1571	0.41	1735	0.55	1879	0.70	2009	0.86	2129	1.02
1750	1665	0.49	1822	0.64	1962	0.80	2088	0.96	2205	1.13
1875	1762	0.58	1911	0.74	2046	0.91	2169	1.08	2283	1.26
2000	1859	0.68	2001	0.85	2132	1.02	2252	1.21	2363	1.39
2125	1957	0.79	2093	0.97	2219	1.15	2335	1.34	2444	1.54
2250	2055	0.92	2185	1.10	2307	1.30	2420	1.50	2527	1.70
2375	2156	1.06	2279	1.25	2397	1.45	2507	1.66	2610	1.88
2500	2256	1.21	2374	1.41	2487	1.62	2594	1.84	2695	2.07

CFM	AVAILABLE EXTERNAL STATIC PRESSURE (in. wg)									
	1.2		1.4		1.6		1.8		2.0	
	rpm	bhp	rpm	bhp	rpm	bhp	rpm	bhp	rpm	bhp
1500	2169	1.08	2277	1.25	2379	1.43	2477	1.61	2572	1.80
1625	2240	1.19	2345	1.37	2445	1.55	2541	1.74	2633	1.93
1750	2314	1.31	2417	1.49	2514	1.68	2608	1.88	2698	2.08
1875	2389	1.44	2490	1.63	2586	1.83	2677	2.03	2766	2.24
2000	2467	1.59	2565	1.78	2659	1.99	2749	2.20	2836	2.41
2125	2546	1.74	2643	1.95	2734	2.16	2823	2.38	—	—
2250	2627	1.91	2721	2.13	2812	2.35	—	—	—	—
2375	2708	2.10	2801	2.32	—	—	—	—	—	—
2500	2791	2.30	—	—	—	—	—	—	—	—

Standard/Medium Static 1478-2390 rpm, 1.44 maximum bhp

High Static 1478-2836 rpm, 2.43 maximum bhp

48FEFA06 Three Phase — Standard/Medium Static — 5 Ton Vertical Supply (rpm - vdc)

CFM	AVAILABLE EXTERNAL STATIC PRESSURE (in. wg)									
	0.2		0.4		0.6		0.8		1.0	
	rpm	vdc	rpm	vdc	rpm	vdc	rpm	vdc	rpm	vdc
1500	1478	6.2	1650	6.9	1798	7.5	1932	8.1	2055	8.6
1625	1571	6.6	1735	7.3	1879	7.9	2009	8.4	2129	8.9
1750	1665	7.0	1822	7.6	1962	8.2	2088	8.7	2205	9.2
1875	1762	7.4	1911	8.0	2046	8.6	2169	9.1	2283	9.6
2000	1859	7.8	2001	8.4	2132	8.9	2252	9.4	2363	9.9
2125	1957	8.2	2093	8.8	2219	9.3	2335	9.8	—	—
2250	2055	8.6	2185	9.1	2307	9.7	—	—	—	—
2375	2156	9.0	2279	9.5	—	—	—	—	—	—
2500	2256	9.4	2374	9.9	—	—	—	—	—	—

CFM	AVAILABLE EXTERNAL STATIC PRESSURE (in. wg)									
	1.2		1.4		1.6		1.8		2.0	
	rpm	vdc	rpm	vdc	rpm	vdc	rpm	vdc	rpm	vdc
1500	2169	9.1	2277	9.5	2379	10.0	—	—	—	—
1625	2240	9.4	2345	9.8	—	—	—	—	—	—
1750	2314	9.7	—	—	—	—	—	—	—	—
1875	2389	10.0	—	—	—	—	—	—	—	—
2000	—	—	—	—	—	—	—	—	—	—
2125	—	—	—	—	—	—	—	—	—	—
2250	—	—	—	—	—	—	—	—	—	—
2375	—	—	—	—	—	—	—	—	—	—
2500	—	—	—	—	—	—	—	—	—	—

Standard/Medium Static 1478-2390 rpm

48FEFA06 Three Phase — High Static — 5 Ton Vertical Supply (rpm - vdc)

CFM	AVAILABLE EXTERNAL STATIC PRESSURE (in. wg)									
	0.2		0.4		0.6		0.8		1.0	
	rpm	vdc	rpm	vdc	rpm	vdc	rpm	vdc	rpm	vdc
1500	1478	5.2	1650	5.8	1798	6.3	1932	6.8	2055	7.2
1625	1571	5.5	1735	6.1	1879	6.6	2009	7.1	2129	7.5
1750	1665	5.9	1822	6.4	1962	6.9	2088	7.4	2205	7.8
1875	1762	6.2	1911	6.7	2046	7.2	2169	7.6	2283	8.1
2000	1859	6.6	2001	7.1	2132	7.5	2252	7.9	2363	8.3
2125	1957	6.9	2093	7.4	2219	7.8	2335	8.2	2444	8.6
2250	2055	7.2	2185	7.7	2307	8.1	2420	8.5	2527	8.9
2375	2156	7.6	2279	8.0	2397	8.5	2507	8.8	2610	9.2
2500	2256	8.0	2374	8.4	2487	8.8	2594	9.1	2695	9.5

CFM	AVAILABLE EXTERNAL STATIC PRESSURE (in. wg)									
	1.2		1.4		1.6		1.8		2.0	
	rpm	vdc	rpm	vdc	rpm	vdc	rpm	vdc	rpm	vdc
1500	2169	7.6	2277	8.0	2379	8.4	2477	8.7	2572	9.1
1625	2240	7.9	2345	8.3	2445	8.6	2541	9.0	2633	9.3
1750	2314	8.2	2417	8.5	2514	8.9	2608	9.2	2698	9.5
1875	2389	8.4	2490	8.8	2586	9.1	2677	9.4	2766	9.8
2000	2467	8.7	2565	9.0	2659	9.4	2749	9.7	2836	10.0
2125	2546	9.0	2643	9.3	2734	9.6	2823	10.0	—	—
2250	2627	9.3	2721	9.6	2812	9.9	—	—	—	—
2375	2708	9.5	2801	9.9	—	—	—	—	—	—
2500	2791	9.8	—	—	—	—	—	—	—	—

High Static 1478-2836 rpm

48FEFM07 Three Phase — 6 Ton Vertical Supply (rpm - bhp)

CFM	AVAILABLE EXTERNAL STATIC PRESSURE (in. wg)									
	0.2		0.4		0.6		0.8		1.0	
	rpm	bhp	rpm	bhp	rpm	bhp	rpm	bhp	rpm	bhp
1800	1596	0.43	1749	0.56	1889	0.71	2015	0.86	2131	1.02
1950	1704	0.52	1847	0.67	1981	0.82	2104	0.98	2217	1.15
2100	1814	0.63	1948	0.78	2075	0.94	2194	1.12	2305	1.29
2250	1924	0.75	2050	0.91	2172	1.08	2286	1.26	2394	1.45
2400	2037	0.89	2155	1.06	2270	1.24	2381	1.43	2485	1.62
2550	2150	1.05	2261	1.22	2370	1.41	2476	1.61	2578	1.81
2700	2265	1.23	2368	1.40	2472	1.60	2574	1.80	2672	2.02
2850	2379	1.43	2477	1.61	2576	1.81	2674	2.02	2768	2.24
3000	2495	1.64	2587	1.83	2681	2.04	2775	2.26	—	—

CFM	AVAILABLE EXTERNAL STATIC PRESSURE (in. wg)									
	1.2		1.4		1.6		1.8		2.0	
	rpm	bhp	rpm	bhp	rpm	bhp	rpm	bhp	rpm	bhp
1800	2239	1.19	2340	1.35	2436	1.53	2528	1.71	2615	1.89
1950	2323	1.32	2422	1.50	2516	1.68	2605	1.87	2691	2.06
2100	2408	1.47	2505	1.66	2597	1.85	2685	2.04	2770	2.25
2250	2495	1.64	2590	1.84	2681	2.04	2767	2.24	—	—
2400	2584	1.82	2677	2.03	2766	2.24	—	—	—	—
2550	2674	2.02	2766	2.24	—	—	—	—	—	—
2700	2766	2.24	—	—	—	—	—	—	—	—
2850	—	—	—	—	—	—	—	—	—	—
3000	—	—	—	—	—	—	—	—	—	—

Standard/Medium Static 1596-2530 rpm, 1.76 maximum bhp

High Static 1596-2836 rpm, 2.43 maximum bhp

48FEFM07 Three Phase — Standard/Medium Static — 6 Ton Vertical Supply (rpm - vdc)

CFM	AVAILABLE EXTERNAL STATIC PRESSURE (in. wg)									
	0.2		0.4		0.6		0.8		1.0	
	rpm	vdc	rpm	vdc	rpm	vdc	rpm	vdc	rpm	vdc
1800	1596	6.3	1749	6.9	1889	7.5	2015	8.0	2131	8.4
1950	1704	6.7	1847	7.3	1981	7.8	2104	8.3	2217	8.8
2100	1814	7.2	1948	7.7	2075	8.2	2194	8.7	2305	9.1
2250	1925	7.6	2050	8.1	2172	8.6	2286	9.0	2394	9.5
2400	2037	8.1	2154	8.5	2270	9.0	2381	9.4	2485	9.8
2550	2150	8.5	2261	8.9	2370	9.4	2477	9.8	—	—
2700	2265	9.0	2368	9.4	2472	9.8	—	—	—	—
2850	2379	9.4	2477	9.8	—	—	—	—	—	—
3000	2495	9.9	—	—	—	—	—	—	—	—

CFM	AVAILABLE EXTERNAL STATIC PRESSURE (in. wg)									
	1.2		1.4		1.6		1.8		2.0	
	rpm	vdc	rpm	vdc	rpm	vdc	rpm	vdc	rpm	vdc
1800	2239	8.8	2340	9.2	2436	9.6	2527	10.0	—	—
1950	2323	9.2	2422	9.6	2516	9.9	—	—	—	—
2100	2408	9.5	2505	9.9	—	—	—	—	—	—
2250	2495	9.9	—	—	—	—	—	—	—	—
2400	—	—	—	—	—	—	—	—	—	—
2550	—	—	—	—	—	—	—	—	—	—
2700	—	—	—	—	—	—	—	—	—	—
2850	—	—	—	—	—	—	—	—	—	—
3000	—	—	—	—	—	—	—	—	—	—

Standard/Medium Static 1596-2530 rpm

48FEFM07 Three Phase — High Static — 6 Ton Vertical Supply (rpm - vdc)

CFM	AVAILABLE EXTERNAL STATIC PRESSURE (in. wg)									
	0.2		0.4		0.6		0.8		1.0	
	rpm	vdc	rpm	vdc	rpm	vdc	rpm	vdc	rpm	vdc
1800	1596	5.6	1749	6.2	1889	6.7	2015	7.1	2131	7.5
1950	1704	6.0	1847	6.5	1981	7.0	2104	7.4	2217	7.8
2100	1814	6.4	1948	6.9	2075	7.3	2194	7.7	2305	8.1
2250	1925	6.8	2050	7.2	2172	7.7	2286	8.1	2394	8.4
2400	2037	7.2	2154	7.6	2270	8.0	2381	8.4	2485	8.8
2550	2150	7.6	2261	8.0	2370	8.4	2477	8.7	2578	9.1
2700	2265	8.0	2368	8.3	2472	8.7	2574	9.1	2672	9.4
2850	2379	8.4	2477	8.7	2576	9.1	2674	9.4	2768	9.8
3000	2495	8.8	2587	9.1	2681	9.5	2775	9.8	—	—

CFM	AVAILABLE EXTERNAL STATIC PRESSURE (in. wg)									
	1.2		1.4		1.6		1.8		2.0	
	rpm	vdc	rpm	vdc	rpm	vdc	rpm	vdc	rpm	vdc
1800	2239	7.9	2340	8.3	2436	8.6	2527	8.9	2615	9.2
1950	2323	8.2	2422	8.5	2516	8.9	2605	9.2	2691	9.5
2100	2408	8.5	2505	8.8	2597	9.2	2685	9.5	2770	9.8
2250	2495	8.8	2590	9.1	2681	9.5	2767	9.8	—	—
2400	2584	9.1	2677	9.4	2766	9.8	—	—	—	—
2550	2674	9.4	2766	9.8	—	—	—	—	—	—
2700	2766	9.8	—	—	—	—	—	—	—	—
2850	—	—	—	—	—	—	—	—	—	—
3000	—	—	—	—	—	—	—	—	—	—

High Static 1596-2836 rpm

48FEEA04 Single Phase — 3 Ton Horizontal Supply (rpm - bhp)

CFM	AVAILABLE EXTERNAL STATIC PRESSURE (in. wg)									
	0.2		0.4		0.6		0.8		1.0	
	rpm	bhp	rpm	bhp	rpm	bhp	rpm	bhp	rpm	bhp
900	1079	0.09	1315	0.16	1510	0.24	1679	0.33	1830	0.43
975	1126	0.10	1355	0.17	1546	0.26	1713	0.35	1863	0.45
1050	1175	0.11	1396	0.19	1584	0.28	1749	0.37	1897	0.48
1125	1226	0.13	1438	0.21	1622	0.30	1785	0.40	1932	0.50
1200	1278	0.15	1482	0.23	1662	0.32	1822	0.42	1968	0.53
1275	1331	0.16	1528	0.25	1703	0.34	1861	0.45	2004	0.56
1350	1386	0.19	1575	0.27	1746	0.37	1900	0.48	2042	0.59
1425	1441	0.21	1623	0.30	1789	0.40	1941	0.51	2080	0.63
1500	1498	0.23	1672	0.33	1834	0.43	1982	0.54	2119	0.66

CFM	AVAILABLE EXTERNAL STATIC PRESSURE (in. wg)									
	1.2		1.4		1.6		1.8		2.0	
	rpm	bhp	rpm	bhp	rpm	bhp	rpm	bhp	rpm	bhp
900	1968	0.53	2096	0.64	2215	0.76	2328	0.88	2434	1.00
975	2000	0.56	2127	0.67	2246	0.79	2358	0.91	2464	1.04
1050	2033	0.59	2159	0.70	2277	0.82	2389	0.95	—	—
1125	2067	0.61	2192	0.73	2309	0.86	2420	0.99	—	—
1200	2101	0.65	2225	0.77	2342	0.89	2452	1.03	—	—
1275	2136	0.68	2260	0.80	2376	0.93	2485	1.07	—	—
1350	2172	0.71	2295	0.84	2410	0.97	—	—	—	—
1425	2209	0.75	2330	0.88	2445	1.02	—	—	—	—
1500	2247	0.79	2367	0.92	2480	1.06	—	—	—	—

Standard/Medium Static 1079-2190 rpm, 0.71 maximum bhp

High Static 1079-2490 rpm, 1.07 maximum bhp

48FEEA04 Single Phase — Standard/Medium Static — 3 Ton Horizontal Supply (rpm - vdc)

CFM	AVAILABLE EXTERNAL STATIC PRESSURE (in. wg)									
	0.2		0.4		0.6		0.8		1.0	
	rpm	vdc	rpm	vdc	rpm	vdc	rpm	vdc	rpm	vdc
900	1079	4.9	1315	6.0	1510	6.9	1679	7.7	1830	8.4
975	1126	5.1	1355	6.2	1546	7.1	1713	7.8	1863	8.5
1050	1175	5.4	1396	6.4	1584	7.2	1749	8.0	1897	8.7
1125	1226	5.6	1438	6.6	1622	7.4	1785	8.2	1932	8.8
1200	1278	5.8	1482	6.8	1662	7.6	1822	8.3	1968	9.0
1275	1331	6.1	1528	7.0	1703	7.8	1861	8.5	2004	9.2
1350	1386	6.3	1575	7.2	1746	8.0	1900	8.7	2042	9.3
1425	1441	6.6	1623	7.4	1789	8.2	1941	8.9	2080	9.5
1500	1498	6.8	1672	7.6	1834	8.4	1982	9.1	2119	9.7

CFM	AVAILABLE EXTERNAL STATIC PRESSURE (in. wg)									
	1.2		1.4		1.6		1.8		2.0	
	rpm	vdc	rpm	vdc	rpm	vdc	rpm	vdc	rpm	vdc
900	1968	9.0	2096	9.6	—	—	—	—	—	—
975	2000	9.1	2127	9.7	—	—	—	—	—	—
1050	2033	9.3	2159	9.9	—	—	—	—	—	—
1125	2067	9.4	—	—	—	—	—	—	—	—
1200	2101	9.6	—	—	—	—	—	—	—	—
1275	2136	9.8	—	—	—	—	—	—	—	—
1350	2172	9.9	—	—	—	—	—	—	—	—
1425	—	—	—	—	—	—	—	—	—	—
1500	—	—	—	—	—	—	—	—	—	—

Standard/Medium Static 1079-2190 rpm

48FEEA04 Single Phase — High Static — 3 Ton Horizontal Supply (rpm - vdc)

CFM	AVAILABLE EXTERNAL STATIC PRESSURE (in. wg)									
	0.2		0.4		0.6		0.8		1.0	
	rpm	vdc	rpm	vdc	rpm	vdc	rpm	vdc	rpm	vdc
900	1079	4.3	1315	5.3	1510	6.1	1679	6.7	1830	7.3
975	1126	4.5	1355	5.4	1546	6.2	1713	6.9	1863	7.5
1050	1175	4.7	1396	5.6	1584	6.4	1749	7.0	1897	7.6
1125	1226	4.9	1438	5.8	1622	6.5	1785	7.2	1932	7.8
1200	1278	5.1	1482	6.0	1662	6.7	1822	7.3	1968	7.9
1275	1331	5.3	1528	6.1	1703	6.8	1861	7.5	2004	8.0
1350	1386	5.6	1575	6.3	1746	7.0	1900	7.6	2042	8.2
1425	1441	5.8	1623	6.5	1789	7.2	1941	7.8	2080	8.4
1500	1498	6.0	1672	6.7	1834	7.4	1982	8.0	2119	8.5

CFM	AVAILABLE EXTERNAL STATIC PRESSURE (in. wg)									
	1.2		1.4		1.6		1.8		2.0	
	rpm	vdc	rpm	vdc	rpm	vdc	rpm	vdc	rpm	vdc
900	1968	7.9	2096	8.4	2215	8.9	2328	9.3	2434	9.8
975	2000	8.0	2127	8.5	2246	9.0	2358	9.5	2464	9.9
1050	2033	8.2	2159	8.7	2277	9.1	2389	9.6	—	—
1125	2067	8.3	2192	8.8	2309	9.3	2420	9.7	—	—
1200	2101	8.4	2225	8.9	2342	9.4	2452	9.8	—	—
1275	2136	8.6	2260	9.1	2376	9.5	2485	10.0	—	—
1350	2172	8.7	2295	9.2	2410	9.7	—	—	—	—
1425	2209	8.9	2330	9.4	2445	9.8	—	—	—	—
1500	2247	9.0	2367	9.5	2480	10.0	—	—	—	—

High Static 1079-2490 rpm

48FEEA04 Three Phase — 3 Ton Horizontal Supply (rpm - bhp)

CFM	AVAILABLE EXTERNAL STATIC PRESSURE (in. wg)									
	0.2		0.4		0.6		0.8		1.0	
	rpm	bhp	rpm	bhp	rpm	bhp	rpm	bhp	rpm	bhp
900	1079	0.09	1315	0.16	1510	0.24	1679	0.33	1830	0.43
975	1126	0.10	1355	0.17	1546	0.26	1713	0.35	1863	0.45
1050	1175	0.11	1396	0.19	1584	0.28	1749	0.37	1897	0.48
1125	1226	0.13	1438	0.21	1622	0.30	1785	0.40	1932	0.50
1200	1278	0.15	1482	0.23	1662	0.32	1822	0.42	1968	0.53
1275	1331	0.16	1528	0.25	1703	0.34	1861	0.45	2004	0.56
1350	1386	0.19	1575	0.27	1746	0.37	1900	0.48	2042	0.59
1425	1441	0.21	1623	0.30	1789	0.40	1941	0.51	2080	0.63
1500	1498	0.23	1672	0.33	1834	0.43	1982	0.54	2119	0.66

CFM	AVAILABLE EXTERNAL STATIC PRESSURE (in. wg)									
	1.2		1.4		1.6		1.8		2.0	
	rpm	bhp	rpm	bhp	rpm	bhp	rpm	bhp	rpm	bhp
900	1968	0.53	2096	0.64	2215	0.76	2328	0.88	2434	1.00
975	2000	0.56	2127	0.67	2246	0.79	2358	0.91	2464	1.04
1050	2033	0.59	2159	0.70	2277	0.82	2389	0.95	—	—
1125	2067	0.61	2192	0.73	2309	0.86	2420	0.99	—	—
1200	2101	0.65	2225	0.77	2342	0.89	2452	1.03	—	—
1275	2136	0.68	2260	0.80	2376	0.93	2485	1.07	—	—
1350	2172	0.71	2295	0.84	2410	0.97	—	—	—	—
1425	2209	0.75	2330	0.88	2445	1.02	—	—	—	—
1500	2247	0.79	2367	0.92	2480	1.06	—	—	—	—

Standard/Medium Static 1079-2190 rpm, 0.71 maximum bhp

High Static 1079-2490 rpm, 1.07 maximum bhp

48FEEA04 Three Phase — Standard/Medium Static — 3 Ton Horizontal Supply (rpm - vdc)

CFM	AVAILABLE EXTERNAL STATIC PRESSURE (in. wg)									
	0.2		0.4		0.6		0.8		1.0	
	rpm	vdc	rpm	vdc	rpm	vdc	rpm	vdc	rpm	vdc
900	1079	4.9	1315	6.0	1510	6.9	1679	7.7	1830	8.4
975	1126	5.1	1355	6.2	1546	7.1	1713	7.8	1863	8.5
1050	1175	5.4	1396	6.4	1584	7.2	1749	8.0	1897	8.7
1125	1226	5.6	1438	6.6	1622	7.4	1785	8.2	1932	8.8
1200	1278	5.8	1482	6.8	1662	7.6	1822	8.3	1968	9.0
1275	1331	6.1	1528	7.0	1703	7.8	1861	8.5	2004	9.2
1350	1386	6.3	1575	7.2	1746	8.0	1900	8.7	2042	9.3
1425	1441	6.6	1623	7.4	1789	8.2	1941	8.9	2080	9.5
1500	1498	6.8	1672	7.6	1834	8.4	1982	9.1	2119	9.7

CFM	AVAILABLE EXTERNAL STATIC PRESSURE (in. wg)									
	1.2		1.4		1.6		1.8		2.0	
	rpm	vdc	rpm	vdc	rpm	vdc	rpm	vdc	rpm	vdc
900	1968	9.0	2096	9.6	—	—	—	—	—	—
975	2000	9.1	2127	9.7	—	—	—	—	—	—
1050	2033	9.3	2159	9.9	—	—	—	—	—	—
1125	2067	9.4	—	—	—	—	—	—	—	—
1200	2101	9.6	—	—	—	—	—	—	—	—
1275	2136	9.8	—	—	—	—	—	—	—	—
1350	2172	9.9	—	—	—	—	—	—	—	—
1425	—	—	—	—	—	—	—	—	—	—
1500	—	—	—	—	—	—	—	—	—	—

Standard/Medium Static 1079-2190 rpm

48FEEA04 Three Phase — High Static — 3 Ton Horizontal Supply (rpm - vdc)

CFM	AVAILABLE EXTERNAL STATIC PRESSURE (in. wg)									
	0.2		0.4		0.6		0.8		1.0	
	rpm	vdc	rpm	vdc	rpm	vdc	rpm	vdc	rpm	vdc
900	1079	4.3	1315	5.3	1510	6.1	1679	6.7	1830	7.3
975	1126	4.5	1355	5.4	1546	6.2	1713	6.9	1863	7.5
1050	1175	4.7	1396	5.6	1584	6.4	1749	7.0	1897	7.6
1125	1226	4.9	1438	5.8	1622	6.5	1785	7.2	1932	7.8
1200	1278	5.1	1482	6.0	1662	6.7	1822	7.3	1968	7.9
1275	1331	5.3	1528	6.1	1703	6.8	1861	7.5	2004	8.0
1350	1386	5.6	1575	6.3	1746	7.0	1900	7.6	2042	8.2
1425	1441	5.8	1623	6.5	1789	7.2	1941	7.8	2080	8.4
1500	1498	6.0	1672	6.7	1834	7.4	1982	8.0	2119	8.5

CFM	AVAILABLE EXTERNAL STATIC PRESSURE (in. wg)									
	1.2		1.4		1.6		1.8		2.0	
	rpm	vdc	rpm	vdc	rpm	vdc	rpm	vdc	rpm	vdc
900	1968	7.9	2096	8.4	2215	8.9	2328	9.3	2434	9.8
975	2000	8.0	2127	8.5	2246	9.0	2358	9.5	2464	9.9
1050	2033	8.2	2159	8.7	2277	9.1	2389	9.6	—	—
1125	2067	8.3	2192	8.8	2309	9.3	2420	9.7	—	—
1200	2101	8.4	2225	8.9	2342	9.4	2452	9.8	—	—
1275	2136	8.6	2260	9.1	2376	9.5	2485	10.0	—	—
1350	2172	8.7	2295	9.2	2410	9.7	—	—	—	—
1425	2209	8.9	2330	9.4	2445	9.8	—	—	—	—
1500	2247	9.0	2367	9.5	2480	10.0	—	—	—	—

High Static 1079-2490 rpm

48FEFA05 Single Phase — 4 Ton Horizontal Supply (rpm - bhp)

CFM	AVAILABLE EXTERNAL STATIC PRESSURE (in. wg)									
	0.2		0.4		0.6		0.8		1.0	
	rpm	bhp	rpm	bhp	rpm	bhp	rpm	bhp	rpm	bhp
1200	1217	0.19	1411	0.30	1576	0.42	1722	0.55	1855	0.68
1300	1283	0.23	1470	0.34	1631	0.46	1774	0.60	1904	0.74
1400	1351	0.26	1531	0.38	1688	0.51	1827	0.65	1955	0.80
1500	1420	0.31	1593	0.43	1746	0.57	1883	0.71	2008	0.86
1600	1491	0.35	1657	0.48	1805	0.63	1939	0.78	2062	0.93
1700	1563	0.41	1722	0.54	1866	0.69	1997	0.85	2118	1.01
1800	1635	0.46	1789	0.61	1928	0.76	2056	0.92	2174	1.09
1900	1709	0.53	1856	0.68	1991	0.84	2116	1.01	2232	1.18
2000	1784	0.60	1925	0.76	2056	0.92	2178	1.10	2291	1.28

CFM	AVAILABLE EXTERNAL STATIC PRESSURE (in. wg)									
	1.2		1.4		1.6		1.8		2.0	
	rpm	bhp	rpm	bhp	rpm	bhp	rpm	bhp	rpm	bhp
1200	1979	0.83	2094	0.98	2204	1.15	2308	1.32	2409	1.50
1300	2025	0.89	2138	1.05	2246	1.21	2349	1.39	2447	1.57
1400	2074	0.95	2185	1.11	2291	1.28	2391	1.46	—	—
1500	2124	1.02	2234	1.19	2338	1.36	2436	1.54	—	—
1600	2176	1.10	2284	1.27	2386	1.45	—	—	—	—
1700	2230	1.18	2336	1.36	2436	1.54	—	—	—	—
1800	2285	1.27	2389	1.45	—	—	—	—	—	—
1900	2341	1.36	2444	1.55	—	—	—	—	—	—
2000	2398	1.46	—	—	—	—	—	—	—	—

Standard/Medium Static 1217-2170 rpm, 1.06 maximum bhp

High Static 1216-2460 rpm, 1.53 maximum bhp

48FEFA05 Single Phase — Standard/Medium Static — 4 Ton Horizontal Supply (rpm - vdc)

CFM	AVAILABLE EXTERNAL STATIC PRESSURE (in. wg)									
	0.2		0.4		0.6		0.8		1.0	
	rpm	vdc	rpm	vdc	rpm	vdc	rpm	vdc	rpm	vdc
1200	1217	5.6	1411	6.5	1576	7.3	1722	7.9	1855	8.5
1300	1283	5.9	1470	6.8	1631	7.5	1774	8.2	1904	8.8
1400	1351	6.2	1531	7.1	1688	7.8	1827	8.4	1955	9.0
1500	1420	6.5	1593	7.3	1746	8.0	1883	8.7	2008	9.3
1600	1491	6.9	1657	7.6	1805	8.3	1939	8.9	2062	9.5
1700	1563	7.2	1722	7.9	1866	8.6	1997	9.2	2118	9.8
1800	1635	7.5	1789	8.2	1928	8.9	2056	9.5	—	—
1900	1709	7.9	1856	8.6	1991	9.2	2116	9.8	—	—
2000	1784	8.2	1925	8.9	2056	9.5	—	—	—	—

CFM	AVAILABLE EXTERNAL STATIC PRESSURE (in. wg)									
	1.2		1.4		1.6		1.8		2.0	
	rpm	vdc	rpm	vdc	rpm	vdc	rpm	vdc	rpm	vdc
1200	1979	9.1	2094	9.6	—	—	—	—	—	—
1300	2025	9.3	2138	9.9	—	—	—	—	—	—
1400	2074	9.6	—	—	—	—	—	—	—	—
1500	2124	9.8	—	—	—	—	—	—	—	—
1600	—	—	—	—	—	—	—	—	—	—
1700	—	—	—	—	—	—	—	—	—	—
1800	—	—	—	—	—	—	—	—	—	—
1900	—	—	—	—	—	—	—	—	—	—
2000	—	—	—	—	—	—	—	—	—	—

Standard/Medium Static 1217-2170 rpm

48FEFA05 Single Phase — High Static — 4 Ton Horizontal Supply (rpm - vdc)

CFM	AVAILABLE EXTERNAL STATIC PRESSURE (in. wg)									
	0.2		0.4		0.6		0.8		1.0	
	rpm	vdc	rpm	vdc	rpm	vdc	rpm	vdc	rpm	vdc
1200	1217	4.9	1411	5.7	1576	6.4	1722	7.0	1855	7.5
1300	1283	5.2	1470	6.0	1631	6.6	1774	7.2	1904	7.7
1400	1351	5.5	1531	6.2	1688	6.9	1827	7.4	1955	7.9
1500	1420	5.8	1593	6.5	1746	7.1	1883	7.7	2008	8.2
1600	1491	6.1	1657	6.7	1805	7.3	1939	7.9	2062	8.4
1700	1563	6.4	1722	7.0	1866	7.6	1997	8.1	2118	8.6
1800	1635	6.6	1789	7.3	1928	7.8	2056	8.4	2174	8.8
1900	1709	6.9	1856	7.5	1991	8.1	2116	8.6	2232	9.1
2000	1784	7.3	1925	7.8	2056	8.4	2178	8.9	2291	9.3

CFM	AVAILABLE EXTERNAL STATIC PRESSURE (in. wg)									
	1.2		1.4		1.6		1.8		2.0	
	rpm	vdc	rpm	vdc	rpm	vdc	rpm	vdc	rpm	vdc
1200	1979	8.0	2094	8.5	2204	9.0	2308	9.4	2409	9.8
1300	2025	8.2	2138	8.7	2246	9.1	2349	9.5	2447	9.9
1400	2074	8.4	2185	8.9	2291	9.3	2391	9.7	—	—
1500	2124	8.6	2234	9.1	2338	9.5	2436	9.9	—	—
1600	2176	8.8	2284	9.3	2386	9.7	—	—	—	—
1700	2230	9.1	2336	9.5	2436	9.9	—	—	—	—
1800	2285	9.3	2389	9.7	—	—	—	—	—	—
1900	2341	9.5	2444	9.9	—	—	—	—	—	—
2000	2398	9.7	—	—	—	—	—	—	—	—

High Static 1217-2460 rpm

48FEFA05 Three Phase — 4 Ton Horizontal Supply (rpm - bhp)

CFM	AVAILABLE EXTERNAL STATIC PRESSURE (in. wg)									
	0.2		0.4		0.6		0.8		1.0	
	rpm	bhp	rpm	bhp	rpm	bhp	rpm	bhp	rpm	bhp
1200	1216	0.19	1411	0.30	1576	0.42	1722	0.55	1855	0.68
1300	1282	0.23	1470	0.34	1631	0.46	1773	0.60	1904	0.74
1400	1351	0.26	1531	0.38	1688	0.51	1827	0.65	1955	0.80
1500	1420	0.31	1593	0.43	1746	0.57	1882	0.71	2008	0.86
1600	1491	0.35	1657	0.48	1806	0.63	1940	0.78	2062	0.93
1700	1563	0.41	1722	0.54	1866	0.69	1997	0.85	2118	1.01
1800	1636	0.47	1788	0.61	1928	0.76	2056	0.92	2175	1.09
1900	1710	0.53	1856	0.68	1991	0.84	2116	1.01	2233	1.18
2000	1784	0.60	1924	0.76	2055	0.92	2178	1.10	2292	1.28

CFM	AVAILABLE EXTERNAL STATIC PRESSURE (in. wg)									
	1.2		1.4		1.6		1.8		2.0	
	rpm	bhp	rpm	bhp	rpm	bhp	rpm	bhp	rpm	bhp
1200	1978	0.83	2094	0.98	2204	1.15	2308	1.32	2409	1.50
1300	2025	0.89	2139	1.05	2246	1.21	2349	1.39	2447	1.57
1400	2073	0.95	2185	1.11	2291	1.28	2392	1.46	2488	1.64
1500	2124	1.02	2233	1.19	2337	1.36	2437	1.54	2532	1.73
1600	2176	1.10	2284	1.27	2386	1.45	2483	1.63	2577	1.82
1700	2230	1.18	2336	1.36	2436	1.54	2532	1.73	2624	1.92
1800	2285	1.27	2389	1.45	2488	1.64	2582	1.83	—	—
1900	2341	1.36	2443	1.55	2541	1.74	2634	1.94	—	—
2000	2399	1.46	2499	1.66	2595	1.85	—	—	—	—

Standard/Medium Static 1216-2170 rpm, 1.06 maximum bhp

High Static 1216-2660 rpm, 1.96 maximum bhp

48FEFA05 Three Phase — Standard/Medium Static — 4 Ton Horizontal Supply (rpm - vdc)

CFM	AVAILABLE EXTERNAL STATIC PRESSURE (in. wg)									
	0.2		0.4		0.6		0.8		1.0	
	rpm	vdc	rpm	vdc	rpm	vdc	rpm	vdc	rpm	vdc
1200	1216	5.6	1411	6.5	1576	7.3	1722	7.9	1855	8.5
1300	1282	5.9	1470	6.8	1631	7.5	1773	8.2	1904	8.8
1400	1351	6.2	1531	7.1	1688	7.8	1827	8.4	1955	9.0
1500	1420	6.5	1593	7.3	1746	8.0	1882	8.7	2008	9.3
1600	1491	6.9	1657	7.6	1806	8.3	1940	8.9	2062	9.5
1700	1563	7.2	1722	7.9	1866	8.6	1997	9.2	2118	9.8
1800	1636	7.5	1788	8.2	1928	8.9	2056	9.5	—	—
1900	1710	7.9	1856	8.6	1991	9.2	2116	9.8	—	—
2000	1784	8.2	1924	8.9	2055	9.5	—	—	—	—

CFM	AVAILABLE EXTERNAL STATIC PRESSURE (in. wg)									
	1.2		1.4		1.6		1.8		2.0	
	rpm	vdc	rpm	vdc	rpm	vdc	rpm	vdc	rpm	vdc
1200	1978	9.1	2094	9.6	—	—	—	—	—	—
1300	2025	9.3	2139	9.9	—	—	—	—	—	—
1400	2073	9.6	—	—	—	—	—	—	—	—
1500	2124	9.8	—	—	—	—	—	—	—	—
1600	—	—	—	—	—	—	—	—	—	—
1700	—	—	—	—	—	—	—	—	—	—
1800	—	—	—	—	—	—	—	—	—	—
1900	—	—	—	—	—	—	—	—	—	—
2000	—	—	—	—	—	—	—	—	—	—

Standard/Medium Static 1216-2170 rpm,

48FEFA05 Three Phase — High Static — 4 Ton Horizontal Supply (rpm - vdc)

CFM	AVAILABLE EXTERNAL STATIC PRESSURE (in. wg)									
	0.2		0.4		0.6		0.8		1.0	
	rpm	vdc	rpm	vdc	rpm	vdc	rpm	vdc	rpm	vdc
1200	1216	4.6	1411	5.3	1576	5.9	1722	6.5	1855	7.0
1300	1282	4.8	1470	5.5	1631	6.1	1773	6.7	1904	7.2
1400	1351	5.1	1531	5.8	1688	6.3	1827	6.9	1955	7.3
1500	1420	5.3	1593	6.0	1746	6.6	1882	7.1	2008	7.5
1600	1491	5.6	1657	6.2	1806	6.8	1940	7.3	2062	7.8
1700	1563	5.9	1722	6.5	1866	7.0	1997	7.5	2118	8.0
1800	1636	6.2	1788	6.7	1928	7.2	2056	7.7	2175	8.2
1900	1710	6.4	1856	7.0	1991	7.5	2116	8.0	2233	8.4
2000	1784	6.7	1924	7.2	2055	7.7	2178	8.2	2292	8.6

CFM	AVAILABLE EXTERNAL STATIC PRESSURE (in. wg)									
	1.2		1.4		1.6		1.8		2.0	
	rpm	vdc	rpm	vdc	rpm	vdc	rpm	vdc	rpm	vdc
1200	1978	7.4	2094	7.9	2204	8.3	2308	8.7	2409	9.1
1300	2025	7.6	2139	8.0	2246	8.4	2349	8.8	2447	9.2
1400	2073	7.8	2185	8.2	2291	8.6	2392	9.0	2488	9.4
1500	2124	8.0	2233	8.4	2337	8.8	2437	9.2	2532	9.5
1600	2176	8.2	2284	8.6	2386	9.0	2483	9.3	2577	9.7
1700	2230	8.4	2336	8.8	2436	9.2	2532	9.5	2624	9.9
1800	2285	8.6	2389	9.0	2488	9.4	2582	9.7	—	—
1900	2341	8.8	2443	9.2	2541	9.6	2634	9.9	—	—
2000	2399	9.0	2499	9.4	2595	9.8	—	—	—	—

High Static 1216-2660 rpm

48FEFA06 Single Phase — 5 Ton Horizontal Supply (rpm - bhp)

CFM	AVAILABLE EXTERNAL STATIC PRESSURE (in. wg)									
	0.2		0.4		0.6		0.8		1.0	
	rpm	bhp	rpm	bhp	rpm	bhp	rpm	bhp	rpm	bhp
1500	1420	0.31	1593	0.43	1746	0.57	1883	0.71	2008	0.86
1625	1509	0.37	1674	0.50	1820	0.64	1954	0.79	2076	0.95
1750	1599	0.43	1756	0.58	1897	0.73	2027	0.89	2146	1.05
1875	1691	0.51	1839	0.66	1976	0.82	2101	0.98	2218	1.16
2000	1784	0.60	1925	0.76	2056	0.92	2178	1.10	2292	1.28
2125	1879	0.70	2011	0.86	2138	1.04	2256	1.22	2367	1.41
2250	1974	0.81	2100	0.98	2221	1.16	2335	1.35	2444	1.55
2375	2070	0.94	2189	1.11	2306	1.30	2417	1.49	2522	1.70
2500	2166	1.08	2280	1.25	2392	1.45	2499	1.65	2602	1.86

CFM	AVAILABLE EXTERNAL STATIC PRESSURE (in. wg)									
	1.2		1.4		1.6		1.8		2.0	
	rpm	bhp	rpm	bhp	rpm	bhp	rpm	bhp	rpm	bhp
1500	2124	1.02	2234	1.19	2338	1.36	2437	1.54	2532	1.73
1625	2190	1.12	2297	1.29	2399	1.47	2496	1.65	2589	1.85
1750	2258	1.22	2363	1.40	2462	1.59	2557	1.78	2649	1.98
1875	2327	1.34	2430	1.52	2528	1.72	2621	1.91	—	—
2000	2398	1.46	2499	1.66	2596	1.86	—	—	—	—
2125	2471	1.60	2570	1.80	—	—	—	—	—	—
2250	2546	1.75	2643	1.96	—	—	—	—	—	—
2375	2622	1.91	—	—	—	—	—	—	—	—
2500	—	—	—	—	—	—	—	—	—	—

Standard/Medium Static 1420-2390 rpm, 1.44 maximum bhp

High Static 1420-2660 rpm, 1.96 maximum bhp

48FEFA06 Single Phase — Standard/Medium Static — 5 Ton Horizontal Supply (rpm - vdc)

CFM	AVAILABLE EXTERNAL STATIC PRESSURE (in. wg)									
	0.2		0.4		0.6		0.8		1.0	
	rpm	vdc	rpm	vdc	rpm	vdc	rpm	vdc	rpm	vdc
1500	1420	5.9	1593	6.7	1746	7.3	1883	7.9	2008	8.4
1625	1509	6.3	1673	7.0	1820	7.6	1954	8.2	2076	8.7
1750	1599	6.7	1755	7.3	1897	7.9	2026	8.5	2146	9.0
1875	1691	7.1	1839	7.7	1975	8.3	2101	8.8	2218	9.3
2000	1784	7.5	1925	8.1	2056	8.6	2178	9.1	2291	9.6
2125	1878	7.9	2011	8.4	2138	8.9	2255	9.4	2367	9.9
2250	1974	8.3	2100	8.8	2221	9.3	2335	9.8	—	—
2375	2070	8.7	2189	9.2	2305	9.6	—	—	—	—
2500	2166	9.1	2280	9.5	—	—	—	—	—	—

CFM	AVAILABLE EXTERNAL STATIC PRESSURE (in. wg)									
	1.2		1.4		1.6		1.8		2.0	
	rpm	vdc	rpm	vdc	rpm	vdc	rpm	vdc	rpm	vdc
1500	2124	8.9	2234	9.3	2338	9.8	—	—	—	—
1625	2190	9.2	2297	9.6	—	—	—	—	—	—
1750	2257	9.4	2362	9.9	—	—	—	—	—	—
1875	2327	9.7	—	—	—	—	—	—	—	—
2000	—	—	—	—	—	—	—	—	—	—
2125	—	—	—	—	—	—	—	—	—	—
2250	—	—	—	—	—	—	—	—	—	—
2375	—	—	—	—	—	—	—	—	—	—
2500	—	—	—	—	—	—	—	—	—	—

Standard/Medium Static 1420-2390 rpm

48FEFA06 Single Phase — High Static — 5 Ton Horizontal Supply (rpm - vdc)

CFM	AVAILABLE EXTERNAL STATIC PRESSURE (in. wg)									
	0.2		0.4		0.6		0.8		1.0	
	rpm	vdc	rpm	vdc	rpm	vdc	rpm	vdc	rpm	vdc
1500	1420	5.3	1593	6.0	1746	6.6	1883	7.1	2008	7.5
1625	1509	5.7	1674	6.3	1820	6.8	1954	7.3	2076	7.8
1750	1599	6.0	1756	6.6	1897	7.1	2027	7.6	2146	8.1
1875	1691	6.4	1839	6.9	1976	7.4	2101	7.9	2218	8.3
2000	1784	6.7	1925	7.2	2056	7.7	2178	8.2	2292	8.6
2125	1879	7.1	2011	7.6	2138	8.0	2256	8.5	2367	8.9
2250	1974	7.4	2100	7.9	2221	8.3	2335	8.8	2444	9.2
2375	2070	7.8	2189	8.2	2306	8.7	2417	9.1	2522	9.5
2500	2166	8.1	2280	8.6	2392	9.0	2499	9.4	2602	9.8

CFM	AVAILABLE EXTERNAL STATIC PRESSURE (in. wg)									
	1.2		1.4		1.6		1.8		2.0	
	rpm	vdc	rpm	vdc	rpm	vdc	rpm	vdc	rpm	vdc
1500	2124	8.0	2234	8.4	2338	8.8	2437	9.2	2532	9.5
1625	2190	8.2	2297	8.6	2399	9.0	2496	9.4	2589	9.7
1750	2258	8.5	2363	8.9	2462	9.3	2557	9.6	2649	10.0
1875	2327	8.7	2430	9.1	2528	9.5	2621	9.9	—	—
2000	2398	9.0	2499	9.4	2596	9.8	—	—	—	—
2125	2471	9.3	2570	9.7	—	—	—	—	—	—
2250	2546	9.6	2643	9.9	—	—	—	—	—	—
2375	2622	9.9	—	—	—	—	—	—	—	—
2500	—	—	—	—	—	—	—	—	—	—

High Static 1420-2660 rpm

48FEFA06 Three Phase — 5 Ton Horizontal Supply (rpm - bhp)

CFM	AVAILABLE EXTERNAL STATIC PRESSURE (in. wg)									
	0.2		0.4		0.6		0.8		1.0	
	rpm	bhp	rpm	bhp	rpm	bhp	rpm	bhp	rpm	bhp
1500	1420	0.31	1593	0.43	1746	0.57	1883	0.71	2008	0.86
1625	1509	0.37	1673	0.50	1820	0.64	1954	0.79	2076	0.95
1750	1599	0.43	1755	0.57	1897	0.73	2026	0.88	2146	1.05
1875	1691	0.51	1839	0.66	1976	0.82	2102	0.99	2218	1.16
2000	1784	0.60	1924	0.76	2056	0.92	2178	1.10	2291	1.28
2125	1878	0.70	2011	0.86	2137	1.03	2256	1.22	2367	1.41
2250	1974	0.81	2099	0.98	2221	1.16	2335	1.35	2444	1.55
2375	2070	0.94	2189	1.11	2305	1.30	2416	1.49	2522	1.70
2500	2166	1.08	2280	1.25	2391	1.45	2499	1.65	2601	1.86

CFM	AVAILABLE EXTERNAL STATIC PRESSURE (in. wg)									
	1.2		1.4		1.6		1.8		2.0	
	rpm	bhp	rpm	bhp	rpm	bhp	rpm	bhp	rpm	bhp
1500	2124	1.02	2233	1.19	2337	1.36	2436	1.54	2532	1.73
1625	2190	1.12	2296	1.29	2398	1.47	2495	1.65	2589	1.85
1750	2257	1.22	2362	1.40	2462	1.59	2557	1.78	2648	1.97
1875	2327	1.34	2430	1.52	2528	1.72	2621	1.91	2710	2.11
2000	2398	1.46	2499	1.66	2595	1.85	2687	2.06	2775	2.27
2125	2471	1.60	2570	1.80	2665	2.01	2755	2.22	—	—
2250	2546	1.75	2643	1.96	2735	2.17	2824	2.39	—	—
2375	2622	1.91	2717	2.12	2807	2.34	—	—	—	—
2500	2699	2.08	2792	2.30	—	—	—	—	—	—

Standard/Medium Static 1420-2390 rpm, 1.44 maximum bhp

High Static 1420-2836 rpm, 2.43 maximum bhp

48FEFA06 Three Phase — Standard/Medium Static — 5 Ton Horizontal Supply (rpm - vdc)

CFM	AVAILABLE EXTERNAL STATIC PRESSURE (in. wg)									
	0.2		0.4		0.6		0.8		1.0	
	rpm	vdc	rpm	vdc	rpm	vdc	rpm	vdc	rpm	vdc
1500	1420	5.9	1593	6.7	1746	7.3	1883	7.9	2008	8.4
1625	1509	6.3	1673	7.0	1820	7.6	1954	8.2	2076	8.7
1750	1599	6.7	1755	7.3	1897	7.9	2026	8.5	2146	9.0
1875	1691	7.1	1839	7.7	1976	8.3	2102	8.8	2218	9.3
2000	1784	7.5	1924	8.1	2056	8.6	2178	9.1	2291	9.6
2125	1878	7.9	2011	8.4	2137	8.9	2256	9.4	2367	9.9
2250	1974	8.3	2099	8.8	2221	9.3	2335	9.8	—	—
2375	2070	8.7	2189	9.2	2305	9.6	—	—	—	—
2500	2166	9.1	2280	9.5	—	—	—	—	—	—

CFM	AVAILABLE EXTERNAL STATIC PRESSURE (in. wg)									
	1.2		1.4		1.6		1.8		2.0	
	rpm	vdc	rpm	vdc	rpm	vdc	rpm	vdc	rpm	vdc
1500	2124	8.9	2233	9.3	2337	9.8	—	—	—	—
1625	2190	9.2	2296	9.6	—	—	—	—	—	—
1750	2257	9.4	2362	9.9	—	—	—	—	—	—
1875	2327	9.7	—	—	—	—	—	—	—	—
2000	—	—	—	—	—	—	—	—	—	—
2125	—	—	—	—	—	—	—	—	—	—
2250	—	—	—	—	—	—	—	—	—	—
2375	—	—	—	—	—	—	—	—	—	—
2500	—	—	—	—	—	—	—	—	—	—

Standard/Medium Static 1420-2390 rpm

48FEFA06 Three Phase — High Static — 5 Ton Horizontal Supply (rpm - vdc)

CFM	AVAILABLE EXTERNAL STATIC PRESSURE (in. wg)									
	0.2		0.4		0.6		0.8		1.0	
	rpm	vdc	rpm	vdc	rpm	vdc	rpm	vdc	rpm	vdc
1500	1420	5.0	1593	5.6	1746	6.2	1883	6.6	2008	7.1
1625	1509	5.3	1673	5.9	1820	6.4	1954	6.9	2076	7.3
1750	1599	5.6	1755	6.2	1897	6.7	2026	7.1	2146	7.6
1875	1691	6.0	1839	6.5	1976	7.0	2102	7.4	2218	7.8
2000	1784	6.3	1924	6.8	2056	7.2	2178	7.7	2291	8.1
2125	1878	6.6	2011	7.1	2137	7.5	2256	8.0	2367	8.3
2250	1974	7.0	2099	7.4	2221	7.8	2335	8.2	2444	8.6
2375	2070	7.3	2189	7.7	2305	8.1	2416	8.5	2522	8.9
2500	2166	7.6	2280	8.0	2391	8.4	2499	8.8	2601	9.2

CFM	AVAILABLE EXTERNAL STATIC PRESSURE (in. wg)									
	1.2		1.4		1.6		1.8		2.0	
	rpm	vdc	rpm	vdc	rpm	vdc	rpm	vdc	rpm	vdc
1500	2124	7.5	2233	7.9	2337	8.2	2436	8.6	2532	8.9
1625	2190	7.7	2296	8.1	2398	8.5	2495	8.8	2589	9.1
1750	2257	8.0	2362	8.3	2462	8.7	2557	9.0	2648	9.3
1875	2327	8.2	2430	8.6	2528	8.9	2621	9.2	2710	9.6
2000	2398	8.5	2499	8.8	2595	9.2	2687	9.5	2775	9.8
2125	2471	8.7	2570	9.1	2665	9.4	2755	9.7	—	—
2250	2546	9.0	2643	9.3	2735	9.6	2824	10.0	—	—
2375	2622	9.2	2717	9.6	2807	9.9	—	—	—	—
2500	2699	9.5	2792	9.8	—	—	—	—	—	—

High Static 1420-2836 rpm

48FEFM07 Three Phase — 6 Ton Horizontal Supply (rpm - bhp)

CFM	AVAILABLE EXTERNAL STATIC PRESSURE (in. wg)									
	0.2		0.4		0.6		0.8		1.0	
	rpm	bhp	rpm	bhp	rpm	bhp	rpm	bhp	rpm	bhp
1800	1537	0.38	1685	0.51	1824	0.64	1953	0.79	2071	0.94
1950	1641	0.47	1778	0.59	1911	0.74	2035	0.89	2150	1.05
2100	1748	0.56	1874	0.69	2000	0.84	2119	1.00	2231	1.17
2250	1855	0.67	1973	0.81	2091	0.96	2206	1.13	2314	1.31
2400	1964	0.80	2074	0.94	2185	1.10	2294	1.27	2399	1.45
2550	2074	0.94	2176	1.08	2281	1.25	2385	1.43	2486	1.62
2700	2185	1.10	2281	1.25	2379	1.42	2478	1.60	2575	1.80
2850	2296	1.27	2386	1.43	2479	1.60	2573	1.79	2666	1.99
3000	2408	1.47	2493	1.63	2581	1.81	2670	2.00	2759	2.21

CFM	AVAILABLE EXTERNAL STATIC PRESSURE (in. wg)									
	1.2		1.4		1.6		1.8		2.0	
	rpm	bhp	rpm	bhp	rpm	bhp	rpm	bhp	rpm	bhp
1800	2182	1.10	2285	1.26	2382	1.43	2476	1.60	2564	1.78
1950	2258	1.21	2359	1.39	2455	1.56	2547	1.74	2634	1.93
2100	2337	1.35	2436	1.52	2530	1.71	2620	1.90	2706	2.09
2250	2417	1.49	2514	1.67	2606	1.86	2695	2.06	2780	2.26
2400	2499	1.64	2594	1.84	2685	2.04	2771	2.24	—	—
2550	2583	1.81	2676	2.02	2765	2.22	—	—	—	—
2700	2669	2.00	2759	2.21	—	—	—	—	—	—
2850	2757	2.20	—	—	—	—	—	—	—	—
3000	—	—	—	—	—	—	—	—	—	—

Standard/Medium Static 1537-2530 rpm, 1.76 maximum bhp

High Static 1537-2836 rpm, 2.43 maximum bhp

48FEFM07 Three Phase — Standard/Medium Static — 6 Ton Horizontal Supply (rpm - vdc)

CFM	AVAILABLE EXTERNAL STATIC PRESSURE (in. wg)									
	0.2		0.4		0.6		0.8		1.0	
	rpm	vdc	rpm	vdc	rpm	vdc	rpm	vdc	rpm	vdc
1800	1537	6.1	1685	6.7	1824	7.2	1953	7.7	2071	8.2
1950	1641	6.5	1778	7.0	1911	7.6	2035	8.0	2150	8.5
2100	1748	6.9	1874	7.4	2000	7.9	2119	8.4	2231	8.8
2250	1855	7.3	1973	7.8	2091	8.3	2206	8.7	2314	9.1
2400	1964	7.8	2074	8.2	2185	8.6	2294	9.1	2399	9.5
2550	2074	8.2	2176	8.6	2281	9.0	2385	9.4	2486	9.8
2700	2185	8.6	2281	9.0	2379	9.4	2478	9.8	—	—
2850	2296	9.1	2386	9.4	2479	9.8	—	—	—	—
3000	2408	9.5	2493	9.9	—	—	—	—	—	—

CFM	AVAILABLE EXTERNAL STATIC PRESSURE (in. wg)									
	1.2		1.4		1.6		1.8		2.0	
	rpm	vdc	rpm	vdc	rpm	vdc	rpm	vdc	rpm	vdc
1800	2182	8.6	2285	9.0	2382	9.4	2476	9.8	—	—
1950	2258	8.9	2359	9.3	2455	9.7	—	—	—	—
2100	2337	9.2	2436	9.6	2530	10.0	—	—	—	—
2250	2417	9.6	2514	9.9	—	—	—	—	—	—
2400	2499	9.9	—	—	—	—	—	—	—	—
2550	—	—	—	—	—	—	—	—	—	—
2700	—	—	—	—	—	—	—	—	—	—
2850	—	—	—	—	—	—	—	—	—	—
3000	—	—	—	—	—	—	—	—	—	—

Standard/Medium Static 1537-2530 rpm

48FEFM07 Three Phase — High Static — 6 Ton Horizontal Supply (rpm - vdc)

CFM	AVAILABLE EXTERNAL STATIC PRESSURE (in. wg)									
	0.2		0.4		0.6		0.8		1.0	
	rpm	vdc	rpm	vdc	rpm	vdc	rpm	vdc	rpm	vdc
1800	1537	5.4	1685	5.9	1824	6.4	1953	6.9	2071	7.3
1950	1641	5.8	1778	6.3	1911	6.7	2035	7.2	2150	7.6
2100	1748	6.2	1874	6.6	2000	7.1	2119	7.5	2231	7.9
2250	1855	6.5	1973	7.0	2091	7.4	2206	7.8	2314	8.2
2400	1964	6.9	2074	7.3	2185	7.7	2294	8.1	2399	8.5
2550	2074	7.3	2176	7.7	2281	8.0	2385	8.4	2486	8.8
2700	2185	7.7	2281	8.0	2379	8.4	2478	8.7	2575	9.1
2850	2296	8.1	2386	8.4	2479	8.7	2573	9.1	2666	9.4
3000	2408	8.5	2493	8.8	2581	9.1	2670	9.4	2759	9.7

CFM	AVAILABLE EXTERNAL STATIC PRESSURE (in. wg)									
	1.2		1.4		1.6		1.8		2.0	
	rpm	vdc	rpm	vdc	rpm	vdc	rpm	vdc	rpm	vdc
1800	2182	7.7	2285	8.1	2382	8.4	2476	8.7	2564	9.0
1950	2258	8.0	2359	8.3	2455	8.7	2547	9.0	2634	9.3
2100	2337	8.2	2436	8.6	2530	8.9	2620	9.2	2706	9.5
2250	2417	8.5	2514	8.9	2606	9.2	2695	9.5	2780	9.8
2400	2499	8.8	2594	9.1	2685	9.5	2771	9.8	—	—
2550	2583	9.1	2676	9.4	2765	9.7	—	—	—	—
2700	2669	9.4	2759	9.7	—	—	—	—	—	—
2850	2757	9.7	—	—	—	—	—	—	—	—
3000	—	—	—	—	—	—	—	—	—	—

High Static 1537-2836 rpm

50FE-A04 Single Phase — 3 Ton Vertical Supply (rpm - bhp)

CFM	AVAILABLE EXTERNAL STATIC PRESSURE (in. wg)									
	0.2		0.4		0.6		0.8		1.0	
	rpm	bhp	rpm	bhp	rpm	bhp	rpm	bhp	rpm	bhp
900	1040	0.08	1307	0.16	1526	0.25	1705	0.35	1859	0.45
975	1082	0.09	1336	0.17	1554	0.26	1736	0.36	1892	0.47
1050	1127	0.10	1366	0.18	1582	0.28	1766	0.38	1925	0.50
1125	1175	0.11	1398	0.19	1609	0.29	1795	0.40	1956	0.52
1200	1225	0.13	1434	0.21	1638	0.31	1822	0.42	1984	0.54
1275	1277	0.15	1472	0.22	1667	0.32	1849	0.44	2012	0.57
1350	1330	0.16	1514	0.24	1699	0.34	1878	0.46	2040	0.59
1425	1385	0.19	1557	0.26	1734	0.36	1906	0.48	2068	0.62
1500	1440	0.21	1603	0.29	1771	0.39	1937	0.51	2095	0.64

CFM	AVAILABLE EXTERNAL STATIC PRESSURE (in. wg)									
	1.2		1.4		1.6		1.8		2.0	
	rpm	bhp	rpm	bhp	rpm	bhp	rpm	bhp	rpm	bhp
900	1995	0.55	2119	0.66	2234	0.78	2342	0.89	2444	1.02
975	2031	0.58	2156	0.70	2272	0.82	2380	0.94	2482	1.06
1050	2065	0.61	2192	0.73	2309	0.86	2418	0.98	—	—
1125	2098	0.64	2226	0.77	2345	0.90	2454	1.03	—	—
1200	2129	0.67	2259	0.80	2379	0.94	2490	1.07	—	—
1275	2159	0.70	2291	0.84	2412	0.98	—	—	—	—
1350	2187	0.73	2321	0.87	2444	1.02	—	—	—	—
1425	2215	0.76	2350	0.90	2474	1.05	—	—	—	—
1500	2242	0.78	2378	0.94	—	—	—	—	—	—

Standard/Medium Static 1040-2190 rpm, 0.71 maximum bhp

High Static 1040-2490 rpm, 1.07 maximum bhp

50FE-A04 Single Phase — Standard/Medium Static — 3 Ton Vertical Supply (rpm - vdc)

CFM	AVAILABLE EXTERNAL STATIC PRESSURE (in. wg)									
	0.2		0.4		0.6		0.8		1.0	
	rpm	vdc	rpm	vdc	rpm	vdc	rpm	vdc	rpm	vdc
900	1040	4.7	1307	6.0	1526	7.0	1705	7.8	1859	8.5
975	1082	4.9	1336	6.1	1554	7.1	1736	7.9	1892	8.6
1050	1127	5.1	1366	6.2	1582	7.2	1766	8.1	1925	8.8
1125	1175	5.4	1398	6.4	1609	7.3	1795	8.2	1956	8.9
1200	1225	5.6	1434	6.5	1638	7.5	1822	8.3	1984	9.1
1275	1277	5.8	1472	6.7	1667	7.6	1849	8.4	2012	9.2
1350	1330	6.1	1514	6.9	1699	7.8	1878	8.6	2040	9.3
1425	1385	6.3	1557	7.1	1734	7.9	1906	8.7	2068	9.4
1500	1440	6.6	1603	7.3	1771	8.1	1937	8.8	2095	9.6

CFM	AVAILABLE EXTERNAL STATIC PRESSURE (in. wg)									
	1.2		1.4		1.6		1.8		2.0	
	rpm	vdc	rpm	vdc	rpm	vdc	rpm	vdc	rpm	vdc
900	1995	9.1	2119	9.7	—	—	—	—	—	—
975	2031	9.3	2156	9.8	—	—	—	—	—	—
1050	2065	9.4	—	—	—	—	—	—	—	—
1125	2098	9.6	—	—	—	—	—	—	—	—
1200	2129	9.7	—	—	—	—	—	—	—	—
1275	2159	9.9	—	—	—	—	—	—	—	—
1350	2187	10.0	—	—	—	—	—	—	—	—
1425	—	—	—	—	—	—	—	—	—	—
1500	—	—	—	—	—	—	—	—	—	—

Standard/Medium Static 1040-2190 rpm

50FE-A04 Single Phase — High Static — 3 Ton Vertical Supply (rpm - vdc)

CFM	AVAILABLE EXTERNAL STATIC PRESSURE (in. wg)									
	0.2		0.4		0.6		0.8		1.0	
	rpm	vdc	rpm	vdc	rpm	vdc	rpm	vdc	rpm	vdc
900	1040	4.2	1307	5.2	1526	6.1	1705	6.8	1859	7.5
975	1082	4.3	1336	5.4	1554	6.2	1736	7.0	1892	7.6
1050	1127	4.5	1366	5.5	1582	6.4	1766	7.1	1925	7.7
1125	1175	4.7	1398	5.6	1609	6.5	1795	7.2	1956	7.9
1200	1225	4.9	1434	5.8	1638	6.6	1822	7.3	1984	8.0
1275	1277	5.1	1472	5.9	1667	6.7	1849	7.4	2012	8.1
1350	1330	5.3	1514	6.1	1699	6.8	1878	7.5	2040	8.2
1425	1385	5.6	1557	6.3	1734	7.0	1906	7.7	2068	8.3
1500	1440	5.8	1603	6.4	1771	7.1	1937	7.8	2095	8.4

CFM	AVAILABLE EXTERNAL STATIC PRESSURE (in. wg)									
	1.2		1.4		1.6		1.8		2.0	
	rpm	vdc	rpm	vdc	rpm	vdc	rpm	vdc	rpm	vdc
900	1995	8.0	2119	8.5	2234	9.0	2342	9.4	2444	9.8
975	2031	8.2	2156	8.7	2272	9.1	2380	9.6	2482	10.0
1050	2065	8.3	2192	8.8	2309	9.3	2418	9.7	—	—
1125	2098	8.4	2226	8.9	2345	9.4	2454	9.9	—	—
1200	2129	8.6	2259	9.1	2379	9.6	2490	10.0	—	—
1275	2159	8.7	2291	9.2	2412	9.7	—	—	—	—
1350	2187	8.8	2321	9.3	2444	9.8	—	—	—	—
1425	2215	8.9	2350	9.4	2474	9.9	—	—	—	—
1500	2242	9.0	2378	9.6	—	—	—	—	—	—

High Static 1040-2490 rpm

50FE-A04 Three Phase — 3 Ton Vertical Supply (rpm - bhp)

CFM	AVAILABLE EXTERNAL STATIC PRESSURE (in. wg)									
	0.2		0.4		0.6		0.8		1.0	
	rpm	bhp	rpm	bhp	rpm	bhp	rpm	bhp	rpm	bhp
900	1040	0.08	1307	0.16	1526	0.25	1705	0.35	1859	0.45
975	1082	0.09	1336	0.17	1554	0.26	1736	0.36	1892	0.47
1050	1127	0.10	1366	0.18	1582	0.28	1766	0.38	1925	0.50
1125	1175	0.11	1398	0.19	1609	0.29	1795	0.40	1956	0.52
1200	1225	0.13	1434	0.21	1638	0.31	1822	0.42	1984	0.54
1275	1277	0.15	1472	0.22	1667	0.32	1849	0.44	2012	0.57
1350	1330	0.16	1514	0.24	1699	0.34	1878	0.46	2040	0.59
1425	1385	0.19	1557	0.26	1734	0.36	1906	0.48	2068	0.62
1500	1440	0.21	1603	0.29	1771	0.39	1937	0.51	2095	0.64

CFM	AVAILABLE EXTERNAL STATIC PRESSURE (in. wg)									
	1.2		1.4		1.6		1.8		2.0	
	rpm	bhp	rpm	bhp	rpm	bhp	rpm	bhp	rpm	bhp
900	1995	0.55	2119	0.66	2234	0.78	2342	0.89	2444	1.02
975	2031	0.58	2156	0.70	2272	0.82	2380	0.94	2482	1.06
1050	2065	0.61	2192	0.73	2309	0.86	2418	0.98	—	—
1125	2098	0.64	2226	0.77	2345	0.90	2454	1.03	—	—
1200	2129	0.67	2259	0.80	2379	0.94	2490	1.07	—	—
1275	2159	0.70	2291	0.84	2412	0.98	—	—	—	—
1350	2187	0.73	2321	0.87	2444	1.02	—	—	—	—
1425	2215	0.76	2350	0.90	2474	1.05	—	—	—	—
1500	2242	0.78	2378	0.94	—	—	—	—	—	—

Standard/Medium Static 1040-2190 rpm, 0.71 maximum bhp

High Static 1040-2490 rpm, 1.07 maximum bhp

50FE-A04 Three Phase — Standard/Medium Static — 3 Ton Vertical Supply (rpm - vdc)

CFM	AVAILABLE EXTERNAL STATIC PRESSURE (in. wg)									
	0.2		0.4		0.6		0.8		1.0	
	rpm	vdc	rpm	vdc	rpm	vdc	rpm	vdc	rpm	vdc
900	1040	4.7	1307	6.0	1526	7.0	1705	7.8	1859	8.5
975	1082	4.9	1336	6.1	1554	7.1	1736	7.9	1892	8.6
1050	1127	5.1	1366	6.2	1582	7.2	1766	8.1	1925	8.8
1125	1175	5.4	1398	6.4	1609	7.3	1795	8.2	1956	8.9
1200	1225	5.6	1434	6.5	1638	7.5	1822	8.3	1984	9.1
1275	1277	5.8	1472	6.7	1667	7.6	1849	8.4	2012	9.2
1350	1330	6.1	1514	6.9	1699	7.8	1878	8.6	2040	9.3
1425	1385	6.3	1557	7.1	1734	7.9	1906	8.7	2068	9.4
1500	1440	6.6	1603	7.3	1771	8.1	1937	8.8	2095	9.6

CFM	AVAILABLE EXTERNAL STATIC PRESSURE (in. wg)									
	1.2		1.4		1.6		1.8		2.0	
	rpm	vdc	rpm	vdc	rpm	vdc	rpm	vdc	rpm	vdc
900	1995	9.1	2119	9.7	—	—	—	—	—	—
975	2031	9.3	2156	9.8	—	—	—	—	—	—
1050	2065	9.4	—	—	—	—	—	—	—	—
1125	2098	9.6	—	—	—	—	—	—	—	—
1200	2129	9.7	—	—	—	—	—	—	—	—
1275	2159	9.9	—	—	—	—	—	—	—	—
1350	2187	10.0	—	—	—	—	—	—	—	—
1425	—	—	—	—	—	—	—	—	—	—
1500	—	—	—	—	—	—	—	—	—	—

Standard/Medium Static 1040-2190 rpm

50FE-A04 Three Phase — High Static — 3 Ton Vertical Supply (rpm - vdc)

CFM	AVAILABLE EXTERNAL STATIC PRESSURE (in. wg)									
	0.2		0.4		0.6		0.8		1.0	
	rpm	vdc	rpm	vdc	rpm	vdc	rpm	vdc	rpm	vdc
900	1040	4.2	1307	5.2	1526	6.1	1705	6.8	1859	7.5
975	1082	4.3	1336	5.4	1554	6.2	1736	7.0	1892	7.6
1050	1127	4.5	1366	5.5	1582	6.4	1766	7.1	1925	7.7
1125	1175	4.7	1398	5.6	1609	6.5	1795	7.2	1956	7.9
1200	1225	4.9	1434	5.8	1638	6.6	1822	7.3	1984	8.0
1275	1277	5.1	1472	5.9	1667	6.7	1849	7.4	2012	8.1
1350	1330	5.3	1514	6.1	1699	6.8	1878	7.5	2040	8.2
1425	1385	5.6	1557	6.3	1734	7.0	1906	7.7	2068	8.3
1500	1440	5.8	1603	6.4	1771	7.1	1937	7.8	2095	8.4

CFM	AVAILABLE EXTERNAL STATIC PRESSURE (in. wg)									
	1.2		1.4		1.6		1.8		2.0	
	rpm	vdc	rpm	vdc	rpm	vdc	rpm	vdc	rpm	vdc
900	1995	8.0	2119	8.5	2234	9.0	2342	9.4	2444	9.8
975	2031	8.2	2156	8.7	2272	9.1	2380	9.6	2482	10.0
1050	2065	8.3	2192	8.8	2309	9.3	2418	9.7	—	—
1125	2098	8.4	2226	8.9	2345	9.4	2454	9.9	—	—
1200	2129	8.6	2259	9.1	2379	9.6	2490	10.0	—	—
1275	2159	8.7	2291	9.2	2412	9.7	—	—	—	—
1350	2187	8.8	2321	9.3	2444	9.8	—	—	—	—
1425	2215	8.9	2350	9.4	2474	9.9	—	—	—	—
1500	2242	9.0	2378	9.6	—	—	—	—	—	—

High Static 1040-2490 rpm

50FE-A05 Single Phase — 4 Ton Vertical Supply (rpm - bhp)

CFM	AVAILABLE EXTERNAL STATIC PRESSURE (in. wg)									
	0.2		0.4		0.6		0.8		1.0	
	rpm	bhp	rpm	bhp	rpm	bhp	rpm	bhp	rpm	bhp
1200	1120	0.15	1327	0.25	1506	0.37	1667	0.50	1814	0.65
1300	1178	0.18	1375	0.28	1549	0.40	1705	0.54	1849	0.69
1400	1238	0.21	1424	0.31	1593	0.44	1745	0.57	1886	0.73
1500	1300	0.24	1476	0.35	1639	0.47	1788	0.62	1925	0.77
1600	1365	0.27	1530	0.39	1688	0.52	1832	0.66	1966	0.82
1700	1430	0.31	1586	0.43	1737	0.56	1878	0.71	2009	0.87
1800	1497	0.36	1644	0.48	1789	0.61	1925	0.76	2053	0.93
1900	1565	0.41	1703	0.53	1842	0.67	1974	0.82	2099	0.99
2000	1633	0.46	1764	0.59	1897	0.73	2025	0.89	2146	1.05

CFM	AVAILABLE EXTERNAL STATIC PRESSURE (in. wg)									
	1.2		1.4		1.6		1.8		2.0	
	rpm	bhp	rpm	bhp	rpm	bhp	rpm	bhp	rpm	bhp
1200	1950	0.81	2077	0.97	2195	1.15	2307	1.33	2411	1.52
1300	1983	0.85	2108	1.02	2225	1.19	2336	1.38	2442	1.58
1400	2017	0.89	2140	1.06	2256	1.24	2367	1.43	—	—
1500	2053	0.93	2174	1.11	2289	1.29	2399	1.49	—	—
1600	2092	0.98	2210	1.16	2323	1.35	2431	1.55	—	—
1700	2132	1.04	2248	1.22	2359	1.41	—	—	—	—
1800	2173	1.10	2288	1.28	2397	1.47	—	—	—	—
1900	2217	1.16	2329	1.35	2436	1.54	—	—	—	—
2000	2262	1.23	2372	1.42	—	—	—	—	—	—

Standard/Medium Static 1120-2170 rpm, 1.06 maximum bhp

High Static 1120-2460 rpm, 1.53 maximum bhp

50FE-A05 Single Phase — Standard/Medium Static — 4 Ton Vertical Supply (rpm - vdc)

CFM	AVAILABLE EXTERNAL STATIC PRESSURE (in. wg)									
	0.2		0.4		0.6		0.8		1.0	
	rpm	vdc	rpm	vdc	rpm	vdc	rpm	vdc	rpm	vdc
1200	1120	5.2	1327	6.1	1506	6.9	1667	7.7	1814	8.4
1300	1178	5.4	1375	6.3	1549	7.1	1705	7.9	1849	8.5
1400	1238	5.7	1424	6.6	1593	7.3	1745	8.0	1886	8.7
1500	1300	6.0	1476	6.8	1639	7.6	1788	8.2	1925	8.9
1600	1365	6.3	1530	7.1	1688	7.8	1832	8.4	1966	9.1
1700	1430	6.6	1586	7.3	1737	8.0	1878	8.7	2009	9.3
1800	1497	6.9	1644	7.6	1789	8.2	1925	8.9	2053	9.5
1900	1565	7.2	1703	7.8	1842	8.5	1974	9.1	2099	9.7
2000	1633	7.5	1764	8.1	1897	8.7	2025	9.3	2146	9.9

CFM	AVAILABLE EXTERNAL STATIC PRESSURE (in. wg)									
	1.2		1.4		1.6		1.8		2.0	
	rpm	vdc	rpm	vdc	rpm	vdc	rpm	vdc	rpm	vdc
1200	1950	9.0	2077	9.6	—	—	—	—	—	—
1300	1983	9.1	2108	9.7	—	—	—	—	—	—
1400	2017	9.3	2140	9.9	—	—	—	—	—	—
1500	2053	9.5	—	—	—	—	—	—	—	—
1600	2092	9.6	—	—	—	—	—	—	—	—
1700	2132	9.8	—	—	—	—	—	—	—	—
1800	—	—	—	—	—	—	—	—	—	—
1900	—	—	—	—	—	—	—	—	—	—
2000	—	—	—	—	—	—	—	—	—	—

Standard/Medium Static 1120-2170 rpm

50FE-A05 Single Phase — High Static — 4 Ton Vertical Supply (rpm - vdc)

CFM	AVAILABLE EXTERNAL STATIC PRESSURE (in. wg)									
	0.2		0.4		0.6		0.8		1.0	
	rpm	vdc	rpm	vdc	rpm	vdc	rpm	vdc	rpm	vdc
1200	1120	4.6	1327	5.4	1506	6.1	1667	6.8	1814	7.4
1300	1178	4.8	1375	5.6	1549	6.3	1705	6.9	1849	7.5
1400	1238	5.0	1424	5.8	1593	6.5	1745	7.1	1886	7.7
1500	1300	5.3	1476	6.0	1639	6.7	1788	7.3	1925	7.8
1600	1365	5.5	1530	6.2	1688	6.9	1832	7.4	1966	8.0
1700	1430	5.8	1586	6.4	1737	7.1	1878	7.6	2009	8.2
1800	1497	6.1	1644	6.7	1789	7.3	1925	7.8	2053	8.3
1900	1565	6.4	1703	6.9	1842	7.5	1974	8.0	2099	8.5
2000	1633	6.6	1764	7.2	1897	7.7	2025	8.2	2146	8.7

CFM	AVAILABLE EXTERNAL STATIC PRESSURE (in. wg)									
	1.2		1.4		1.6		1.8		2.0	
	rpm	vdc	rpm	vdc	rpm	vdc	rpm	vdc	rpm	vdc
1200	1950	7.9	2077	8.4	2195	8.9	2307	9.4	2411	9.8
1300	1983	8.1	2108	8.6	2225	9.0	2336	9.5	2442	9.9
1400	2017	8.2	2140	8.7	2256	9.2	2367	9.6	—	—
1500	2053	8.3	2174	8.8	2289	9.3	2399	9.8	—	—
1600	2092	8.5	2210	9.0	2323	9.4	2431	9.9	—	—
1700	2132	8.7	2248	9.1	2359	9.6	—	—	—	—
1800	2173	8.8	2288	9.3	2397	9.7	—	—	—	—
1900	2217	9.0	2329	9.5	2436	9.9	—	—	—	—
2000	2262	9.2	2372	9.6	—	—	—	—	—	—

High Static 1120-2460 rpm

50FE-A05 Three Phase — 4 Ton Vertical Supply (rpm - bhp)

CFM	AVAILABLE EXTERNAL STATIC PRESSURE (in. wg)									
	0.2		0.4		0.6		0.8		1.0	
	rpm	bhp	rpm	bhp	rpm	bhp	rpm	bhp	rpm	bhp
1200	1115	0.15	1332	0.26	1513	0.37	1665	0.50	1801	0.63
1300	1174	0.17	1376	0.28	1557	0.41	1709	0.54	1843	0.67
1400	1236	0.20	1422	0.31	1601	0.44	1754	0.58	1887	0.72
1500	1300	0.24	1471	0.34	1644	0.48	1798	0.62	1932	0.77
1600	1366	0.27	1524	0.38	1688	0.51	1841	0.67	1976	0.82
1700	1433	0.31	1579	0.42	1734	0.56	1884	0.71	2020	0.88
1800	1501	0.36	1637	0.47	1783	0.60	1928	0.76	2063	0.93
1900	1570	0.41	1698	0.52	1834	0.66	1973	0.82	2106	0.99
2000	1640	0.47	1761	0.58	1888	0.71	2020	0.88	2150	1.06

CFM	AVAILABLE EXTERNAL STATIC PRESSURE (in. wg)									
	1.2		1.4		1.6		1.8		2.0	
	rpm	bhp	rpm	bhp	rpm	bhp	rpm	bhp	rpm	bhp
1200	1931	0.78	2061	0.95	2200	1.15	2363	1.43	2617	1.94
1300	1967	0.82	2087	0.98	2207	1.16	2332	1.37	2471	1.62
1400	2009	0.87	2123	1.03	2234	1.20	2345	1.38	2460	1.60
1500	2052	0.93	2164	1.09	2271	1.25	2375	1.43	2478	1.63
1600	2097	0.99	2208	1.15	2312	1.32	2412	1.50	2510	1.69
1700	2141	1.05	2252	1.22	2356	1.39	2454	1.58	2548	1.76
1800	2185	1.11	2297	1.29	2400	1.47	2497	1.66	2590	1.85
1900	2229	1.18	2341	1.36	2445	1.55	2542	1.75	2634	1.94
2000	2272	1.25	2385	1.44	2489	1.64	2586	1.84	—	—

Standard/Medium Static 1115-2170 rpm, 1.06 maximum bhp

High Static 1115-2660 rpm, 1.96 maximum bhp

50FE-A05 Three Phase — Standard/Medium Static — 4 Ton Vertical Supply (rpm - vdc)

CFM	AVAILABLE EXTERNAL STATIC PRESSURE (in. wg)									
	0.2		0.4		0.6		0.8		1.0	
	rpm	vdc	rpm	vdc	rpm	vdc	rpm	vdc	rpm	vdc
1200	1115	5.1	1332	6.1	1513	7.0	1665	7.7	1801	8.3
1300	1174	5.4	1376	6.3	1557	7.2	1709	7.9	1843	8.5
1400	1236	5.7	1422	6.6	1601	7.4	1754	8.1	1887	8.7
1500	1300	6.0	1471	6.8	1644	7.6	1798	8.3	1932	8.9
1600	1366	6.3	1524	7.0	1688	7.8	1841	8.5	1976	9.1
1700	1433	6.6	1579	7.3	1734	8.0	1884	8.7	2020	9.3
1800	1501	6.9	1637	7.5	1783	8.2	1928	8.9	2063	9.5
1900	1570	7.2	1698	7.8	1834	8.5	1973	9.1	2106	9.7
2000	1640	7.6	1761	8.1	1888	8.7	2020	9.3	2150	9.9

CFM	AVAILABLE EXTERNAL STATIC PRESSURE (in. wg)									
	1.2		1.4		1.6		1.8		2.0	
	rpm	vdc	rpm	vdc	rpm	vdc	rpm	vdc	rpm	vdc
1200	1931	8.9	2061	9.5	—	—	—	—	—	—
1300	1967	9.1	2087	9.6	—	—	—	—	—	—
1400	2009	9.3	2123	9.8	—	—	—	—	—	—
1500	2052	9.5	—	—	—	—	—	—	—	—
1600	2097	9.7	—	—	—	—	—	—	—	—
1700	2141	9.9	—	—	—	—	—	—	—	—
1800	—	—	—	—	—	—	—	—	—	—
1900	—	—	—	—	—	—	—	—	—	—
2000	—	—	—	—	—	—	—	—	—	—

Standard/Medium Static 1115-2170 rpm

50FE-A05 Three Phase — High Static — 4 Ton Vertical Supply (rpm - vdc)

CFM	AVAILABLE EXTERNAL STATIC PRESSURE (in. wg)									
	0.2		0.4		0.6		0.8		1.0	
	rpm	vdc	rpm	vdc	rpm	vdc	rpm	vdc	rpm	vdc
1200	1115	4.2	1332	5.0	1513	5.7	1665	6.3	1801	6.8
1300	1174	4.4	1376	5.2	1557	5.9	1709	6.4	1843	6.9
1400	1236	4.6	1422	5.3	1601	6.0	1754	6.6	1887	7.1
1500	1300	4.9	1471	5.5	1644	6.2	1798	6.8	1932	7.3
1600	1366	5.1	1524	5.7	1688	6.3	1841	6.9	1976	7.4
1700	1433	5.4	1579	5.9	1734	6.5	1884	7.1	2020	7.6
1800	1501	5.6	1637	6.2	1783	6.7	1928	7.2	2063	7.8
1900	1570	5.9	1698	6.4	1834	6.9	1973	7.4	2106	7.9
2000	1640	6.2	1761	6.6	1888	7.1	2020	7.6	2150	8.1

CFM	AVAILABLE EXTERNAL STATIC PRESSURE (in. wg)									
	1.2		1.4		1.6		1.8		2.0	
	rpm	vdc	rpm	vdc	rpm	vdc	rpm	vdc	rpm	vdc
1200	1931	7.3	2061	7.7	2200	8.3	2363	8.9	2617	9.8
1300	1967	7.4	2087	7.8	2207	8.3	2332	8.8	2471	9.3
1400	2009	7.6	2123	8.0	2234	8.4	2345	8.8	2460	9.2
1500	2052	7.7	2164	8.1	2271	8.5	2375	8.9	2478	9.3
1600	2097	7.9	2208	8.3	2312	8.7	2412	9.1	2510	9.4
1700	2141	8.0	2252	8.5	2356	8.9	2454	9.2	2548	9.6
1800	2185	8.2	2297	8.6	2400	9.0	2497	9.4	2590	9.7
1900	2229	8.4	2341	8.8	2445	9.2	2542	9.6	2634	9.9
2000	2272	8.5	2385	9.0	2489	9.4	2586	9.7	—	—

High Static 1115-2660 rpm

50FE-A06 Single Phase — 5 Ton Vertical Supply (rpm - bhp)

CFM	AVAILABLE EXTERNAL STATIC PRESSURE (in. wg)									
	0.2		0.4		0.6		0.8		1.0	
	rpm	bhp	rpm	bhp	rpm	bhp	rpm	bhp	rpm	bhp
1500	1301	0.24	1477	0.35	1639	0.47	1788	0.62	1925	0.77
1625	1381	0.28	1544	0.40	1700	0.53	1843	0.67	1976	0.83
1750	1463	0.34	1615	0.45	1763	0.59	1901	0.74	2031	0.90
1875	1548	0.40	1688	0.51	1829	0.65	1962	0.81	2088	0.97
2000	1633	0.46	1764	0.59	1897	0.73	2025	0.89	2147	1.06
2125	1720	0.54	1842	0.67	1968	0.81	2090	0.97	2208	1.15
2250	1808	0.63	1922	0.75	2040	0.90	2158	1.07	2271	1.24
2375	1897	0.72	2003	0.85	2115	1.00	2227	1.17	2336	1.35
2500	1987	0.83	2086	0.96	2192	1.12	2299	1.29	2403	1.47

CFM	AVAILABLE EXTERNAL STATIC PRESSURE (in. wg)									
	1.2		1.4		1.6		1.8		2.0	
	rpm	bhp	rpm	bhp	rpm	bhp	rpm	bhp	rpm	bhp
1500	2053	0.93	2174	1.11	2289	1.29	2398	1.49	2502	1.69
1625	2101	1.00	2220	1.18	2332	1.36	2439	1.56	2542	1.77
1750	2152	1.07	2268	1.25	2378	1.44	2483	1.64	2584	1.85
1875	2206	1.15	2318	1.33	2426	1.53	2529	1.73	2628	1.94
2000	2262	1.23	2372	1.42	2477	1.62	2578	1.83	—	—
2125	2320	1.33	2427	1.52	2530	1.72	2628	1.93	—	—
2250	2380	1.43	2485	1.63	2585	1.83	—	—	—	—
2375	2442	1.54	2544	1.75	2642	1.96	—	—	—	—
2500	2506	1.67	2605	1.87	—	—	—	—	—	—

Standard/Medium Static 1301-2390 rpm, 1.44 maximum bhp

High Static 1262-2660 rpm, 1.96 maximum bhp

50FE-A06 Single Phase — Standard/Medium Static — 3 Ton Vertical Supply (rpm - vdc)

CFM	AVAILABLE EXTERNAL STATIC PRESSURE (in. wg)									
	0.2		0.4		0.6		0.8		1.0	
	rpm	vdc	rpm	vdc	rpm	vdc	rpm	vdc	rpm	vdc
1500	1301	5.4	1476	6.2	1639	6.9	1788	7.5	1925	8.1
1625	1381	5.8	1545	6.5	1700	7.1	1843	7.7	1976	8.3
1750	1463	6.1	1615	6.8	1763	7.4	1901	8.0	2031	8.5
1875	1548	6.5	1688	7.1	1828	7.6	1962	8.2	2087	8.7
2000	1633	6.8	1764	7.4	1897	7.9	2025	8.5	2146	9.0
2125	1720	7.2	1842	7.7	1967	8.2	2090	8.7	2208	9.2
2250	1808	7.6	1922	8.0	2040	8.5	2157	9.0	2271	9.5
2375	1897	7.9	2003	8.4	2115	8.8	2227	9.3	2336	9.8
2500	1987	8.3	2086	8.7	2191	9.2	2298	9.6	—	—

CFM	AVAILABLE EXTERNAL STATIC PRESSURE (in. wg)									
	1.2		1.4		1.6		1.8		2.0	
	rpm	vdc	rpm	vdc	rpm	vdc	rpm	vdc	rpm	vdc
1500	2053	8.6	2174	9.1	2289	9.6	—	—	—	—
1625	2101	8.8	2220	9.3	2332	9.8	—	—	—	—
1750	2152	9.0	2268	9.5	2378	9.9	—	—	—	—
1875	2206	9.2	2318	9.7	—	—	—	—	—	—
2000	2262	9.5	2372	9.9	—	—	—	—	—	—
2125	2320	9.7	—	—	—	—	—	—	—	—
2250	2380	10.0	—	—	—	—	—	—	—	—
2375	—	—	—	—	—	—	—	—	—	—
2500	—	—	—	—	—	—	—	—	—	—

Standard/Medium Static 1301-2390 rpm

50FE-A06 Single Phase — High Static — 5 Ton Vertical Supply (rpm - vdc)

CFM	AVAILABLE EXTERNAL STATIC PRESSURE (in. wg)									
	0.2		0.4		0.6		0.8		1.0	
	rpm	vdc	rpm	vdc	rpm	vdc	rpm	vdc	rpm	vdc
1500	1301	4.9	1477	5.6	1639	6.2	1788	6.7	1925	7.2
1625	1381	5.2	1544	5.8	1700	6.4	1843	6.9	1976	7.4
1750	1463	5.5	1615	6.1	1763	6.6	1901	7.1	2031	7.6
1875	1548	5.8	1688	6.3	1829	6.9	1962	7.4	2088	7.8
2000	1633	6.1	1764	6.6	1897	7.1	2025	7.6	2147	8.1
2125	1720	6.5	1842	6.9	1968	7.4	2090	7.9	2208	8.3
2250	1808	6.8	1922	7.2	2040	7.7	2158	8.1	2271	8.5
2375	1897	7.1	2003	7.5	2115	8.0	2227	8.4	2336	8.8
2500	1987	7.5	2086	7.8	2192	8.2	2299	8.6	2403	9.0

CFM	AVAILABLE EXTERNAL STATIC PRESSURE (in. wg)									
	1.2		1.4		1.6		1.8		2.0	
	rpm	vdc	rpm	vdc	rpm	vdc	rpm	vdc	rpm	vdc
1500	2053	7.7	2174	8.2	2289	8.6	2398	9.0	2502	9.4
1625	2101	7.9	2220	8.3	2332	8.8	2439	9.2	2542	9.6
1750	2152	8.1	2268	8.5	2378	8.9	2483	9.3	2584	9.7
1875	2206	8.3	2318	8.7	2426	9.1	2529	9.5	2628	9.9
2000	2262	8.5	2372	8.9	2477	9.3	2578	9.7	—	—
2125	2320	8.7	2427	9.1	2530	9.5	2628	9.9	—	—
2250	2380	8.9	2485	9.3	2585	9.7	—	—	—	—
2375	2442	9.2	2544	9.6	2642	9.9	—	—	—	—
2500	2506	9.4	2605	9.8	—	—	—	—	—	—

High Static 1301-2660 rpm

50FE-A06 Three Phase — 5 Ton Vertical Supply (rpm - bhp)

CFM	AVAILABLE EXTERNAL STATIC PRESSURE (in. wg)									
	0.2		0.4		0.6		0.8		1.0	
	rpm	bhp	rpm	bhp	rpm	bhp	rpm	bhp	rpm	bhp
1500	1301	0.24	1477	0.35	1639	0.47	1788	0.62	1925	0.77
1625	1381	0.28	1545	0.40	1700	0.53	1843	0.67	1977	0.83
1750	1463	0.34	1615	0.45	1763	0.59	1902	0.74	2031	0.90
1875	1548	0.40	1688	0.51	1829	0.65	1962	0.81	2088	0.97
2000	1633	0.46	1764	0.59	1897	0.73	2025	0.89	2147	1.06
2125	1720	0.54	1842	0.67	1968	0.81	2090	0.97	2208	1.15
2250	1809	0.63	1922	0.75	2040	0.90	2158	1.07	2271	1.24
2375	1897	0.72	2003	0.85	2115	1.00	2227	1.17	2336	1.35
2500	1987	0.83	2086	0.96	2192	1.12	2299	1.29	2403	1.47

CFM	AVAILABLE EXTERNAL STATIC PRESSURE (in. wg)									
	1.2		1.4		1.6		1.8		2.0	
	rpm	bhp	rpm	bhp	rpm	bhp	rpm	bhp	rpm	bhp
1500	2053	0.93	2174	1.11	2289	1.29	2398	1.49	2502	1.69
1625	2102	1.00	2220	1.18	2332	1.36	2439	1.56	2542	1.77
1750	2153	1.07	2268	1.25	2378	1.44	2483	1.64	2584	1.85
1875	2206	1.15	2319	1.33	2426	1.53	2529	1.73	2628	1.94
2000	2262	1.23	2372	1.42	2477	1.62	2578	1.83	2675	2.04
2125	2320	1.33	2427	1.52	2530	1.72	2629	1.93	2724	2.15
2250	2380	1.43	2485	1.63	2585	1.83	2682	2.05	2775	2.27
2375	2443	1.55	2544	1.75	2642	1.96	2737	2.17	2828	2.40
2500	2506	1.67	2605	1.87	2701	2.09	2794	2.31	—	—

Standard/Medium Static 1301-2390 rpm, 1.44 maximum bhp

High Static 1301-2836 rpm, 2.43 maximum bhp

50FE-A06 Three Phase — Standard/Medium Static — 5 Ton Vertical Supply (rpm - vdc)

CFM	AVAILABLE EXTERNAL STATIC PRESSURE (in. wg)									
	0.2		0.4		0.6		0.8		1.0	
	rpm	vdc	rpm	vdc	rpm	vdc	rpm	vdc	rpm	vdc
1500	1301	5.4	1477	6.2	1639	6.9	1788	7.5	1925	8.1
1625	1381	5.8	1545	6.5	1700	7.1	1843	7.7	1977	8.3
1750	1463	6.1	1615	6.8	1763	7.4	1902	8.0	2031	8.5
1875	1548	6.5	1688	7.1	1829	7.7	1962	8.2	2088	8.7
2000	1633	6.8	1764	7.4	1897	7.9	2025	8.5	2147	9.0
2125	1720	7.2	1842	7.7	1968	8.2	2090	8.7	2208	9.2
2250	1809	7.6	1922	8.0	2040	8.5	2158	9.0	2271	9.5
2375	1897	7.9	2003	8.4	2115	8.8	2227	9.3	2336	9.8
2500	1987	8.3	2086	8.7	2192	9.2	2299	9.6	—	—

CFM	AVAILABLE EXTERNAL STATIC PRESSURE (in. wg)									
	1.2		1.4		1.6		1.8		2.0	
	rpm	vdc	rpm	vdc	rpm	vdc	rpm	vdc	rpm	vdc
1500	2053	8.6	2174	9.1	2289	9.6	—	—	—	—
1625	2102	8.8	2220	9.3	2332	9.8	—	—	—	—
1750	2153	9.0	2268	9.5	2378	9.9	—	—	—	—
1875	2206	9.2	2319	9.7	—	—	—	—	—	—
2000	2262	9.5	2372	9.9	—	—	—	—	—	—
2125	2320	9.7	—	—	—	—	—	—	—	—
2250	2380	10.0	—	—	—	—	—	—	—	—
2375	—	—	—	—	—	—	—	—	—	—
2500	—	—	—	—	—	—	—	—	—	—

Standard/Medium Static 1301-2390 rpm

50FE-A06 Three Phase — High Static — 5 Ton Vertical Supply (rpm - vdc)

CFM	AVAILABLE EXTERNAL STATIC PRESSURE (in. wg)									
	0.2		0.4		0.6		0.8		1.0	
	rpm	vdc	rpm	vdc	rpm	vdc	rpm	vdc	rpm	vdc
1500	1301	4.6	1477	5.2	1639	5.8	1788	6.3	1925	6.8
1625	1381	4.9	1545	5.4	1700	6.0	1843	6.5	1977	7.0
1750	1463	5.2	1615	5.7	1763	6.2	1902	6.7	2031	7.2
1875	1548	5.5	1688	6.0	1829	6.4	1962	6.9	2088	7.4
2000	1633	5.8	1764	6.2	1897	6.7	2025	7.1	2147	7.6
2125	1720	6.1	1842	6.5	1968	6.9	2090	7.4	2208	7.8
2250	1809	6.4	1922	6.8	2040	7.2	2158	7.6	2271	8.0
2375	1897	6.7	2003	7.1	2115	7.5	2227	7.9	2336	8.2
2500	1987	7.0	2086	7.4	2192	7.7	2299	8.1	2403	8.5

CFM	AVAILABLE EXTERNAL STATIC PRESSURE (in. wg)									
	1.2		1.4		1.6		1.8		2.0	
	rpm	vdc	rpm	vdc	rpm	vdc	rpm	vdc	rpm	vdc
1500	2053	7.2	2174	7.7	2289	8.1	2398	8.5	2502	8.8
1625	2102	7.4	2220	7.8	2332	8.2	2439	8.6	2542	9.0
1750	2153	7.6	2268	8.0	2378	8.4	2483	8.8	2584	9.1
1875	2206	7.8	2319	8.2	2426	8.6	2529	8.9	2628	9.3
2000	2262	8.0	2372	8.4	2477	8.7	2578	9.1	2675	9.4
2125	2320	8.2	2427	8.6	2530	8.9	2629	9.3	2724	9.6
2250	2380	8.4	2485	8.8	2585	9.1	2682	9.5	2775	9.8
2375	2443	8.6	2544	9.0	2642	9.3	2737	9.7	2828	10.0
2500	2506	8.8	2605	9.2	2701	9.5	2794	9.9	—	—

High Static 1301-2836 rpm

50FE-M07 Three Phase — 6 Ton Vertical Supply (rpm - bhp)

CFM	AVAILABLE EXTERNAL STATIC PRESSURE (in. wg)									
	0.2		0.4		0.6		0.8		1.0	
	rpm	bhp	rpm	bhp	rpm	bhp	rpm	bhp	rpm	bhp
1800	1423	0.30	1550	0.39	1682	0.50	1820	0.64	1955	0.79
1950	1521	0.37	1638	0.46	1758	0.57	1883	0.70	2011	0.86
2100	1620	0.45	1730	0.54	1839	0.65	1953	0.78	2071	0.93
2250	1720	0.53	1824	0.64	1924	0.75	2029	0.88	2137	1.02
2400	1820	0.63	1919	0.74	2013	0.85	2109	0.98	2209	1.13
2550	1921	0.74	2016	0.86	2105	0.98	2194	1.11	2286	1.25
2700	2022	0.86	2113	0.99	2198	1.11	2282	1.24	2368	1.39
2850	2123	1.00	2212	1.13	2293	1.26	2373	1.40	2453	1.54
3000	2225	1.15	2311	1.29	2389	1.42	2465	1.56	2541	1.71

CFM	AVAILABLE EXTERNAL STATIC PRESSURE (in. wg)									
	1.2		1.4		1.6		1.8		2.0	
	rpm	bhp	rpm	bhp	rpm	bhp	rpm	bhp	rpm	bhp
1800	2079	0.95	2192	1.11	2296	1.28	2393	1.45	2485	1.62
1950	2133	1.02	2247	1.19	2353	1.37	2451	1.55	2543	1.73
2100	2189	1.10	2301	1.28	2408	1.47	2507	1.66	2601	1.85
2250	2248	1.19	2357	1.37	2462	1.57	2562	1.76	2656	1.97
2400	2312	1.30	2416	1.48	2517	1.67	2616	1.88	2711	2.09
2550	2381	1.41	2479	1.60	2576	1.79	2672	2.00	2765	2.21
2700	2456	1.55	2546	1.73	2638	1.92	2730	2.13	2821	2.35
2850	2535	1.70	2619	1.88	2705	2.07	2793	2.28	—	—
3000	2618	1.87	2696	2.05	2777	2.24	—	—	—	—

Standard/Medium Static 1423-2530 rpm, 1.76 maximum bhp

High Static 1423-2836 rpm, 2.43 maximum bhp

50FE-M07 Three Phase — Standard/Medium Static — 6 Ton Vertical Supply (rpm - vdc)

CFM	AVAILABLE EXTERNAL STATIC PRESSURE (in. wg)									
	0.2		0.4		0.6		0.8		1.0	
	rpm	vdc	rpm	vdc	rpm	vdc	rpm	vdc	rpm	vdc
1800	1423	5.6	1550	6.1	1682	6.6	1820	7.2	1955	7.7
1950	1521	6.0	1638	6.5	1758	6.9	1883	7.4	2011	7.9
2100	1620	6.4	1730	6.8	1839	7.3	1953	7.7	2071	8.2
2250	1720	6.8	1824	7.2	1924	7.6	2029	8.0	2137	8.4
2400	1820	7.2	1919	7.6	2013	8.0	2109	8.3	2209	8.7
2550	1921	7.6	2016	8.0	2105	8.3	2194	8.7	2286	9.0
2700	2022	8.0	2113	8.4	2198	8.7	2282	9.0	2368	9.4
2850	2123	8.4	2212	8.7	2293	9.1	2373	9.4	2453	9.7
3000	2225	8.8	2311	9.1	2389	9.4	2465	9.7	—	—

CFM	AVAILABLE EXTERNAL STATIC PRESSURE (in. wg)									
	1.2		1.4		1.6		1.8		2.0	
	rpm	vdc	rpm	vdc	rpm	vdc	rpm	vdc	rpm	vdc
1800	2079	8.2	2192	8.7	2296	9.1	2393	9.5	2485	9.8
1950	2133	8.4	2247	8.9	2353	9.3	2451	9.7	—	—
2100	2189	8.7	2301	9.1	2408	9.5	2507	9.9	—	—
2250	2248	8.9	2357	9.3	2462	9.7	—	—	—	—
2400	2312	9.1	2416	9.5	2517	9.9	—	—	—	—
2550	2381	9.4	2479	9.8	—	—	—	—	—	—
2700	2456	9.7	—	—	—	—	—	—	—	—
2850	—	—	—	—	—	—	—	—	—	—
3000	—	—	—	—	—	—	—	—	—	—

Standard/Medium Static 1423-2530 rpm

50FE-M07 Three Phase — High Static — 6 Ton Vertical Supply (rpm - vdc)

CFM	AVAILABLE EXTERNAL STATIC PRESSURE (in. wg)									
	0.2		0.4		0.6		0.8		1.0	
	rpm	vdc	rpm	vdc	rpm	vdc	rpm	vdc	rpm	vdc
1800	1423	5.0	1550	5.5	1682	5.9	1820	6.4	1955	6.9
1950	1521	5.4	1638	5.8	1758	6.2	1883	6.6	2011	7.1
2100	1620	5.7	1730	6.1	1839	6.5	1953	6.9	2071	7.3
2250	1720	6.1	1824	6.4	1924	6.8	2029	7.2	2137	7.5
2400	1820	6.4	1919	6.8	2013	7.1	2109	7.4	2209	7.8
2550	1921	6.8	2016	7.1	2105	7.4	2194	7.7	2286	8.1
2700	2022	7.1	2113	7.5	2198	7.8	2282	8.0	2368	8.3
2850	2123	7.5	2212	7.8	2293	8.1	2373	8.4	2453	8.6
3000	2225	7.8	2311	8.1	2389	8.4	2465	8.7	2541	9.0

CFM	AVAILABLE EXTERNAL STATIC PRESSURE (in. wg)									
	1.2		1.4		1.6		1.8		2.0	
	rpm	vdc	rpm	vdc	rpm	vdc	rpm	vdc	rpm	vdc
1800	2079	7.3	2192	7.7	2296	8.1	2393	8.4	2485	8.8
1950	2133	7.5	2247	7.9	2353	8.3	2451	8.6	2543	9.0
2100	2189	7.7	2301	8.1	2408	8.5	2507	8.8	2601	9.2
2250	2248	7.9	2357	8.3	2462	8.7	2562	9.0	2656	9.4
2400	2312	8.2	2416	8.5	2517	8.9	2616	9.2	2711	9.6
2550	2381	8.4	2479	8.7	2576	9.1	2672	9.4	2765	9.7
2700	2456	8.7	2546	9.0	2638	9.3	2730	9.6	2821	9.9
2850	2535	8.9	2619	9.2	2705	9.5	2793	9.8	—	—
3000	2618	9.2	2696	9.5	2777	9.8	—	—	—	—

High Static 1423-2836 rpm

50FE-A04 Single Phase — 3 Ton Horizontal Supply (rpm - bhp)

CFM	AVAILABLE EXTERNAL STATIC PRESSURE (in. wg)									
	0.2		0.4		0.6		0.8		1.0	
	rpm	bhp	rpm	bhp	rpm	bhp	rpm	bhp	rpm	bhp
900	1017	0.07	1284	0.15	1501	0.24	1684	0.33	1843	0.44
975	1055	0.08	1311	0.16	1527	0.25	1711	0.35	1871	0.46
1050	1096	0.09	1340	0.17	1553	0.26	1737	0.36	1899	0.48
1125	1140	0.10	1371	0.18	1580	0.27	1763	0.38	1925	0.50
1200	1186	0.12	1404	0.19	1608	0.29	1789	0.40	1951	0.52
1275	1236	0.13	1440	0.21	1637	0.31	1816	0.42	1977	0.54
1350	1286	0.15	1477	0.22	1666	0.32	1843	0.44	2004	0.56
1425	1338	0.17	1517	0.24	1698	0.34	1871	0.46	2030	0.58
1500	1391	0.19	1559	0.26	1733	0.36	1900	0.48	2057	0.61

CFM	AVAILABLE EXTERNAL STATIC PRESSURE (in. wg)									
	1.2		1.4		1.6		1.8		2.0	
	rpm	bhp	rpm	bhp	rpm	bhp	rpm	bhp	rpm	bhp
900	1984	0.54	2113	0.66	2231	0.77	2342	0.89	2446	1.02
975	2014	0.57	2144	0.69	2264	0.81	2376	0.93	2481	1.06
1050	2043	0.59	2174	0.72	2295	0.84	2408	0.97	—	—
1125	2071	0.62	2203	0.74	2325	0.88	2439	1.01	—	—
1200	2098	0.64	2231	0.77	2354	0.91	2469	1.05	—	—
1275	2124	0.67	2258	0.80	2382	0.94	—	—	—	—
1350	2150	0.69	2285	0.83	2410	0.97	—	—	—	—
1425	2176	0.72	2311	0.86	2436	1.01	—	—	—	—
1500	2202	0.74	2337	0.89	2462	1.04	—	—	—	—

Standard/Medium Static 1017-2190 rpm, 0.71 maximum bhp

High Static 1017-2490 rpm, 1.07 maximum bhp

50FE-A04 Single Phase — Standard/Medium Static — 3 Ton Horizontal Supply (rpm - vdc)

CFM	AVAILABLE EXTERNAL STATIC PRESSURE (in. wg)									
	0.2		0.4		0.6		0.8		1.0	
	rpm	vdc	rpm	vdc	rpm	vdc	rpm	vdc	rpm	vdc
900	1017	4.6	1284	5.9	1501	6.9	1684	7.7	1843	8.4
975	1055	4.8	1311	6.0	1527	7.0	1711	7.8	1871	8.5
1050	1096	5.0	1340	6.1	1553	7.1	1737	7.9	1899	8.7
1125	1140	5.2	1371	6.3	1580	7.2	1763	8.1	1925	8.8
1200	1186	5.4	1404	6.4	1608	7.3	1789	8.2	1951	8.9
1275	1236	5.6	1440	6.6	1637	7.5	1816	8.3	1977	9.0
1350	1286	5.9	1477	6.7	1666	7.6	1843	8.4	2004	9.2
1425	1338	6.1	1517	6.9	1698	7.8	1871	8.5	2030	9.3
1500	1391	6.4	1559	7.1	1733	7.9	1900	8.7	2057	9.4

CFM	AVAILABLE EXTERNAL STATIC PRESSURE (in. wg)									
	1.2		1.4		1.6		1.8		2.0	
	rpm	vdc	rpm	vdc	rpm	vdc	rpm	vdc	rpm	vdc
900	1984	9.1	2113	9.6	—	—	—	—	—	—
975	2014	9.2	2144	9.8	—	—	—	—	—	—
1050	2043	9.3	—	—	—	—	—	—	—	—
1125	2071	9.5	—	—	—	—	—	—	—	—
1200	2098	9.6	—	—	—	—	—	—	—	—
1275	2124	9.7	—	—	—	—	—	—	—	—
1350	2150	9.8	—	—	—	—	—	—	—	—
1425	—	—	—	—	—	—	—	—	—	—
1500	—	—	—	—	—	—	—	—	—	—

Standard/Medium Static 1017-2190 rpm

50FE-A04 Single Phase — High Static — 3 Ton Horizontal Supply (rpm - vdc)

CFM	AVAILABLE EXTERNAL STATIC PRESSURE (in. wg)									
	0.2		0.4		0.6		0.8		1.0	
	rpm	vdc	rpm	vdc	rpm	vdc	rpm	vdc	rpm	vdc
900	1017	4.1	1284	5.2	1501	6.0	1684	6.8	1843	7.4
975	1055	4.2	1311	5.3	1527	6.1	1711	6.9	1871	7.5
1050	1096	4.4	1340	5.4	1553	6.2	1737	7.0	1899	7.6
1125	1140	4.6	1371	5.5	1580	6.3	1763	7.1	1925	7.7
1200	1186	4.8	1404	5.6	1608	6.5	1789	7.2	1951	7.8
1275	1236	5.0	1440	5.8	1637	6.6	1816	7.3	1977	7.9
1350	1286	5.2	1477	5.9	1666	6.7	1843	7.4	2004	8.0
1425	1338	5.4	1517	6.1	1698	6.8	1871	7.5	2030	8.2
1500	1391	5.6	1559	6.3	1733	7.0	1900	7.6	2057	8.3

CFM	AVAILABLE EXTERNAL STATIC PRESSURE (in. wg)									
	1.2		1.4		1.6		1.8		2.0	
	rpm	vdc	rpm	vdc	rpm	vdc	rpm	vdc	rpm	vdc
900	1984	8.0	2113	8.5	2231	9.0	2342	9.4	2446	9.8
975	2014	8.1	2144	8.6	2264	9.1	2376	9.5	2481	10.0
1050	2043	8.2	2174	8.7	2295	9.2	2408	9.7	—	—
1125	2071	8.3	2203	8.8	2325	9.3	2439	9.8	—	—
1200	2098	8.4	2231	9.0	2354	9.5	2469	9.9	—	—
1275	2124	8.5	2258	9.1	2382	9.6	—	—	—	—
1350	2150	8.6	2285	9.2	2410	9.7	—	—	—	—
1425	2176	8.7	2311	9.3	2436	9.8	—	—	—	—
1500	2202	8.8	2337	9.4	2462	9.9	—	—	—	—

High Static 1017-2490 rpm

50FE-A04 Three Phase — 3 Ton Horizontal Supply (rpm - bhp)

CFM	AVAILABLE EXTERNAL STATIC PRESSURE (in. wg)									
	0.2		0.4		0.6		0.8		1.0	
	rpm	bhp	rpm	bhp	rpm	bhp	rpm	bhp	rpm	bhp
900	1017	0.07	1284	0.15	1501	0.24	1684	0.33	1843	0.44
975	1055	0.08	1311	0.16	1527	0.25	1711	0.35	1871	0.46
1050	1096	0.09	1340	0.17	1553	0.26	1737	0.36	1899	0.48
1125	1140	0.10	1371	0.18	1580	0.27	1763	0.38	1925	0.50
1200	1186	0.12	1404	0.19	1608	0.29	1789	0.40	1951	0.52
1275	1236	0.13	1440	0.21	1637	0.31	1816	0.42	1977	0.54
1350	1286	0.15	1477	0.22	1666	0.32	1843	0.44	2004	0.56
1425	1338	0.17	1517	0.24	1698	0.34	1871	0.46	2030	0.58
1500	1391	0.19	1559	0.26	1733	0.36	1900	0.48	2057	0.61

CFM	AVAILABLE EXTERNAL STATIC PRESSURE (in. wg)									
	1.2		1.4		1.6		1.8		2.0	
	rpm	bhp	rpm	bhp	rpm	bhp	rpm	bhp	rpm	bhp
900	1984	0.54	2113	0.66	2231	0.77	2342	0.89	2446	1.02
975	2014	0.57	2144	0.69	2264	0.81	2376	0.93	2481	1.06
1050	2043	0.59	2174	0.72	2295	0.84	2408	0.97	—	—
1125	2071	0.62	2203	0.74	2325	0.88	2439	1.01	—	—
1200	2098	0.64	2231	0.77	2354	0.91	2469	1.05	—	—
1275	2124	0.67	2258	0.80	2382	0.94	—	—	—	—
1350	2150	0.69	2285	0.83	2410	0.97	—	—	—	—
1425	2176	0.72	2311	0.86	2436	1.01	—	—	—	—
1500	2202	0.74	2337	0.89	2462	1.04	—	—	—	—

Standard/Medium Static 1017-2190 rpm, 0.71 maximum bhp

High Static 1017-2490 rpm, 1.07 maximum bhp

50FE-A04 Three Phase — Standard/Medium Static — 3 Ton Horizontal Supply (rpm - vdc)

CFM	AVAILABLE EXTERNAL STATIC PRESSURE (in. wg)									
	0.2		0.4		0.6		0.8		1.0	
	rpm	vdc	rpm	vdc	rpm	vdc	rpm	vdc	rpm	vdc
900	1017	4.6	1284	5.9	1501	6.9	1684	7.7	1843	8.4
975	1055	4.8	1311	6.0	1527	7.0	1711	7.8	1871	8.5
1050	1096	5.0	1340	6.1	1553	7.1	1737	7.9	1899	8.7
1125	1140	5.2	1371	6.3	1580	7.2	1763	8.1	1925	8.8
1200	1186	5.4	1404	6.4	1608	7.3	1789	8.2	1951	8.9
1275	1236	5.6	1440	6.6	1637	7.5	1816	8.3	1977	9.0
1350	1286	5.9	1477	6.7	1666	7.6	1843	8.4	2004	9.2
1425	1338	6.1	1517	6.9	1698	7.8	1871	8.5	2030	9.3
1500	1391	6.4	1559	7.1	1733	7.9	1900	8.7	2057	9.4

CFM	AVAILABLE EXTERNAL STATIC PRESSURE (in. wg)									
	1.2		1.4		1.6		1.8		2.0	
	rpm	vdc	rpm	vdc	rpm	vdc	rpm	vdc	rpm	vdc
900	1984	9.1	2113	9.6	—	—	—	—	—	—
975	2014	9.2	2144	9.8	—	—	—	—	—	—
1050	2043	9.3	—	—	—	—	—	—	—	—
1125	2071	9.5	—	—	—	—	—	—	—	—
1200	2098	9.6	—	—	—	—	—	—	—	—
1275	2124	9.7	—	—	—	—	—	—	—	—
1350	2150	9.8	—	—	—	—	—	—	—	—
1425	—	—	—	—	—	—	—	—	—	—
1500	—	—	—	—	—	—	—	—	—	—

Standard/Medium Static 1017-2190 rpm

50FE-A04 Three Phase — High Static — 3 Ton Horizontal Supply (rpm - vdc)

CFM	AVAILABLE EXTERNAL STATIC PRESSURE (in. wg)									
	0.2		0.4		0.6		0.8		1.0	
	rpm	vdc	rpm	vdc	rpm	vdc	rpm	vdc	rpm	vdc
900	1017	4.1	1284	5.2	1501	6.0	1684	6.8	1843	7.4
975	1055	4.2	1311	5.3	1527	6.1	1711	6.9	1871	7.5
1050	1096	4.4	1340	5.4	1553	6.2	1737	7.0	1899	7.6
1125	1140	4.6	1371	5.5	1580	6.3	1763	7.1	1925	7.7
1200	1186	4.8	1404	5.6	1608	6.5	1789	7.2	1951	7.8
1275	1236	5.0	1440	5.8	1637	6.6	1816	7.3	1977	7.9
1350	1286	5.2	1477	5.9	1666	6.7	1843	7.4	2004	8.0
1425	1338	5.4	1517	6.1	1698	6.8	1871	7.5	2030	8.2
1500	1391	5.6	1559	6.3	1733	7.0	1900	7.6	2057	8.3

CFM	AVAILABLE EXTERNAL STATIC PRESSURE (in. wg)									
	1.2		1.4		1.6		1.8		2.0	
	rpm	vdc	rpm	vdc	rpm	vdc	rpm	vdc	rpm	vdc
900	1984	8.0	2113	8.5	2231	9.0	2342	9.4	2446	9.8
975	2014	8.1	2144	8.6	2264	9.1	2376	9.5	2481	10.0
1050	2043	8.2	2174	8.7	2295	9.2	2408	9.7	—	—
1125	2071	8.3	2203	8.8	2325	9.3	2439	9.8	—	—
1200	2098	8.4	2231	9.0	2354	9.5	2469	9.9	—	—
1275	2124	8.5	2258	9.1	2382	9.6	—	—	—	—
1350	2150	8.6	2285	9.2	2410	9.7	—	—	—	—
1425	2176	8.7	2311	9.3	2436	9.8	—	—	—	—
1500	2202	8.8	2337	9.4	2462	9.9	—	—	—	—

High Static 1017-2490 rpm

50FE-A05 Single Phase — 4 Ton Horizontal Supply (rpm - bhp)

CFM	AVAILABLE EXTERNAL STATIC PRESSURE (in. wg)									
	0.2		0.4		0.6		0.8		1.0	
	rpm	bhp	rpm	bhp	rpm	bhp	rpm	bhp	rpm	bhp
1200	1092	0.14	1306	0.24	1497	0.35	1667	0.49	1819	0.64
1300	1148	0.16	1348	0.26	1533	0.38	1700	0.52	1851	0.67
1400	1207	0.18	1394	0.28	1571	0.41	1734	0.55	1882	0.70
1500	1267	0.21	1442	0.31	1612	0.44	1770	0.58	1916	0.73
1600	1329	0.24	1493	0.35	1655	0.47	1808	0.61	1951	0.77
1700	1393	0.28	1546	0.38	1700	0.51	1848	0.65	1988	0.81
1800	1458	0.32	1602	0.42	1748	0.55	1890	0.70	2026	0.86
1900	1523	0.36	1659	0.47	1797	0.60	1934	0.75	2066	0.91
2000	1590	0.41	1719	0.52	1849	0.65	1980	0.80	2108	0.96

CFM	AVAILABLE EXTERNAL STATIC PRESSURE (in. wg)									
	1.2		1.4		1.6		1.8		2.0	
	rpm	bhp	rpm	bhp	rpm	bhp	rpm	bhp	rpm	bhp
1200	1959	0.79	2089	0.96	2211	1.14	2327	1.33	2438	1.53
1300	1988	0.83	2117	1.00	2238	1.18	2352	1.37	—	—
1400	2020	0.86	2146	1.03	2266	1.22	2379	1.41	—	—
1500	2051	0.90	2177	1.08	2296	1.26	2408	1.46	—	—
1600	2084	0.94	2209	1.12	2327	1.31	2438	1.51	—	—
1700	2119	0.99	2242	1.17	2358	1.36	—	—	—	—
1800	2154	1.03	2276	1.22	2391	1.41	—	—	—	—
1900	2191	1.08	2311	1.27	2424	1.47	—	—	—	—
2000	2230	1.14	2347	1.33	2459	1.53	—	—	—	—

Standard/Medium Static 1092-2170 rpm, 1.06 maximum bhp

High Static 1092-2460 rpm, 1.53 maximum bhp

50FE-A05 Single Phase — Standard/Medium Static — 4 Ton Horizontal Supply (rpm - vdc)

CFM	AVAILABLE EXTERNAL STATIC PRESSURE (in. wg)									
	0.2		0.4		0.6		0.8		1.0	
	rpm	vdc	rpm	vdc	rpm	vdc	rpm	vdc	rpm	vdc
1200	1092	5.0	1306	6.0	1497	6.9	1667	7.7	1819	8.4
1300	1148	5.3	1348	6.2	1533	7.1	1700	7.8	1851	8.5
1400	1207	5.6	1394	6.4	1571	7.2	1734	8.0	1882	8.7
1500	1267	5.8	1442	6.6	1612	7.4	1770	8.2	1916	8.8
1600	1329	6.1	1493	6.9	1655	7.6	1808	8.3	1951	9.0
1700	1393	6.4	1546	7.1	1700	7.8	1848	8.5	1988	9.2
1800	1458	6.7	1602	7.4	1748	8.1	1890	8.7	2026	9.3
1900	1523	7.0	1659	7.6	1797	8.3	1934	8.9	2066	9.5
2000	1590	7.3	1719	7.9	1849	8.5	1980	9.1	2108	9.7

CFM	AVAILABLE EXTERNAL STATIC PRESSURE (in. wg)									
	1.2		1.4		1.6		1.8		2.0	
	rpm	vdc	rpm	vdc	rpm	vdc	rpm	vdc	rpm	vdc
1200	1959	9.0	2089	9.6	—	—	—	—	—	—
1300	1988	9.2	2117	9.8	—	—	—	—	—	—
1400	2020	9.3	2146	9.9	—	—	—	—	—	—
1500	2051	9.5	—	—	—	—	—	—	—	—
1600	2084	9.6	—	—	—	—	—	—	—	—
1700	2119	9.8	—	—	—	—	—	—	—	—
1800	2154	9.9	—	—	—	—	—	—	—	—
1900	—	—	—	—	—	—	—	—	—	—
2000	—	—	—	—	—	—	—	—	—	—

Standard/Medium Static 1092-2170 rpm

50FE-A05 Single Phase — High Static — 4 Ton Horizontal Supply (rpm - vdc)

CFM	AVAILABLE EXTERNAL STATIC PRESSURE (in. wg)									
	0.2		0.4		0.6		0.8		1.0	
	rpm	vdc	rpm	vdc	rpm	vdc	rpm	vdc	rpm	vdc
1200	1092	4.4	1306	5.3	1497	6.1	1667	6.8	1819	7.4
1300	1148	4.7	1348	5.5	1533	6.2	1700	6.9	1851	7.5
1400	1207	4.9	1394	5.7	1571	6.4	1734	7.0	1882	7.7
1500	1267	5.2	1442	5.9	1612	6.6	1770	7.2	1916	7.8
1600	1329	5.4	1493	6.1	1655	6.7	1808	7.3	1951	7.9
1700	1393	5.7	1546	6.3	1700	6.9	1848	7.5	1988	8.1
1800	1458	5.9	1602	6.5	1748	7.1	1890	7.7	2026	8.2
1900	1523	6.2	1659	6.7	1797	7.3	1934	7.9	2066	8.4
2000	1590	6.5	1719	7.0	1849	7.5	1980	8.0	2108	8.6

CFM	AVAILABLE EXTERNAL STATIC PRESSURE (in. wg)									
	1.2		1.4		1.6		1.8		2.0	
	rpm	vdc	rpm	vdc	rpm	vdc	rpm	vdc	rpm	vdc
1200	1959	8.0	2089	8.5	2211	9.0	2327	9.5	2438	9.9
1300	1988	8.1	2117	8.6	2238	9.1	2352	9.6	—	—
1400	2020	8.2	2146	8.7	2266	9.2	2379	9.7	—	—
1500	2051	8.3	2177	8.8	2296	9.3	2408	9.8	—	—
1600	2084	8.5	2209	9.0	2327	9.5	2438	9.9	—	—
1700	2119	8.6	2242	9.1	2358	9.6	—	—	—	—
1800	2154	8.8	2276	9.3	2391	9.7	—	—	—	—
1900	2191	8.9	2311	9.4	2424	9.9	—	—	—	—
2000	2230	9.1	2347	9.5	2459	10.0	—	—	—	—

High Static 1092-2460 rpm

50FE-A05 Three Phase — 4 Ton Horizontal Supply (rpm - bhp)

CFM	AVAILABLE EXTERNAL STATIC PRESSURE (in. wg)									
	0.2		0.4		0.6		0.8		1.0	
	rpm	bhp	rpm	bhp	rpm	bhp	rpm	bhp	rpm	bhp
1200	1093	0.14	1306	0.24	1497	0.35	1667	0.49	1819	0.64
1300	1148	0.16	1348	0.26	1533	0.38	1700	0.52	1850	0.67
1400	1206	0.18	1393	0.28	1571	0.41	1734	0.55	1883	0.70
1500	1266	0.21	1442	0.31	1612	0.44	1770	0.58	1916	0.73
1600	1329	0.24	1493	0.35	1655	0.47	1808	0.61	1951	0.77
1700	1393	0.28	1546	0.38	1700	0.51	1848	0.65	1988	0.81
1800	1458	0.32	1602	0.42	1747	0.55	1890	0.70	2026	0.86
1900	1523	0.36	1659	0.47	1797	0.60	1934	0.75	2066	0.91
2000	1590	0.41	1718	0.52	1849	0.65	1980	0.80	2108	0.96

CFM	AVAILABLE EXTERNAL STATIC PRESSURE (in. wg)									
	1.2		1.4		1.6		1.8		2.0	
	rpm	bhp	rpm	bhp	rpm	bhp	rpm	bhp	rpm	bhp
1200	1959	0.79	2089	0.96	2211	1.14	2327	1.33	2438	1.53
1300	1988	0.83	2117	1.00	2238	1.18	2352	1.37	2462	1.57
1400	2019	0.86	2146	1.03	2266	1.22	2379	1.41	2487	1.61
1500	2052	0.90	2177	1.08	2296	1.26	2408	1.46	2515	1.66
1600	2084	0.94	2209	1.12	2327	1.31	2438	1.51	2544	1.71
1700	2119	0.99	2242	1.17	2358	1.36	2469	1.56	2574	1.77
1800	2154	1.03	2276	1.22	2391	1.41	2500	1.61	2605	1.83
1900	2191	1.08	2311	1.27	2424	1.47	2533	1.68	2636	1.89
2000	2230	1.14	2347	1.33	2459	1.53	2566	1.74	—	—

Standard/Medium Static 1093-2170 rpm, 1.06 maximum bhp

High Static 1093-2660 rpm, 1.96 maximum bhp

50FE-A05 Three Phase — Standard/Medium Static — 4 Ton Horizontal Supply (rpm - vdc)

CFM	AVAILABLE EXTERNAL STATIC PRESSURE (in. wg)									
	0.2		0.4		0.6		0.8		1.0	
	rpm	vdc	rpm	vdc	rpm	vdc	rpm	vdc	rpm	vdc
1200	1093	5.0	1306	6.0	1497	6.9	1667	7.7	1819	8.4
1300	1148	5.3	1348	6.2	1533	7.1	1700	7.8	1850	8.5
1400	1206	5.6	1393	6.4	1571	7.2	1734	8.0	1883	8.7
1500	1266	5.8	1442	6.6	1612	7.4	1770	8.2	1916	8.8
1600	1329	6.1	1493	6.9	1655	7.6	1808	8.3	1951	9.0
1700	1393	6.4	1546	7.1	1700	7.8	1848	8.5	1988	9.2
1800	1458	6.7	1602	7.4	1747	8.1	1890	8.7	2026	9.3
1900	1523	7.0	1659	7.6	1797	8.3	1934	8.9	2066	9.5
2000	1590	7.3	1718	7.9	1849	8.5	1980	9.1	2108	9.7

CFM	AVAILABLE EXTERNAL STATIC PRESSURE (in. wg)									
	1.2		1.4		1.6		1.8		2.0	
	rpm	vdc	rpm	vdc	rpm	vdc	rpm	vdc	rpm	vdc
1200	1959	9.0	2089	9.6	—	—	—	—	—	—
1300	1988	9.2	2117	9.8	—	—	—	—	—	—
1400	2019	9.3	2146	9.9	—	—	—	—	—	—
1500	2052	9.5	—	—	—	—	—	—	—	—
1600	2084	9.6	—	—	—	—	—	—	—	—
1700	2119	9.8	—	—	—	—	—	—	—	—
1800	2154	9.9	—	—	—	—	—	—	—	—
1900	—	—	—	—	—	—	—	—	—	—
2000	—	—	—	—	—	—	—	—	—	—

Standard/Medium Static 1093-2170 rpm

50FE-A05 Three Phase — High Static — 4 Ton Horizontal Supply (rpm - vdc)

CFM	AVAILABLE EXTERNAL STATIC PRESSURE (in. wg)									
	0.2		0.4		0.6		0.8		1.0	
	rpm	vdc	rpm	vdc	rpm	vdc	rpm	vdc	rpm	vdc
1200	1093	4.1	1306	4.9	1497	5.6	1667	6.3	1819	6.8
1300	1148	4.3	1348	5.1	1533	5.8	1700	6.4	1850	7.0
1400	1206	4.5	1393	5.2	1571	5.9	1734	6.5	1883	7.1
1500	1266	4.8	1442	5.4	1612	6.1	1770	6.7	1916	7.2
1600	1329	5.0	1493	5.6	1655	6.2	1808	6.8	1951	7.3
1700	1393	5.2	1546	5.8	1700	6.4	1848	6.9	1988	7.5
1800	1458	5.5	1602	6.0	1747	6.6	1890	7.1	2026	7.6
1900	1523	5.7	1659	6.2	1797	6.8	1934	7.3	2066	7.8
2000	1590	6.0	1718	6.5	1849	7.0	1980	7.4	2108	7.9

CFM	AVAILABLE EXTERNAL STATIC PRESSURE (in. wg)									
	1.2		1.4		1.6		1.8		2.0	
	rpm	vdc	rpm	vdc	rpm	vdc	rpm	vdc	rpm	vdc
1200	1959	7.4	2089	7.9	2211	8.3	2327	8.7	2438	9.2
1300	1988	7.5	2117	8.0	2238	8.4	2352	8.8	2462	9.3
1400	2019	7.6	2146	8.1	2266	8.5	2379	8.9	2487	9.3
1500	2052	7.7	2177	8.2	2296	8.6	2408	9.1	2515	9.5
1600	2084	7.8	2209	8.3	2327	8.7	2438	9.2	2544	9.6
1700	2119	8.0	2242	8.4	2358	8.9	2469	9.3	2574	9.7
1800	2154	8.1	2276	8.6	2391	9.0	2500	9.4	2605	9.8
1900	2191	8.2	2311	8.7	2424	9.1	2533	9.5	2636	9.9
2000	2230	8.4	2347	8.8	2459	9.2	2566	9.6	—	—

High Static 1093-2660 rpm

50FE-A06 Single Phase — 5 Ton Horizontal Supply (rpm - bhp)

CFM	AVAILABLE EXTERNAL STATIC PRESSURE (in. wg)									
	0.2		0.4		0.6		0.8		1.0	
	rpm	bhp	rpm	bhp	rpm	bhp	rpm	bhp	rpm	bhp
1500	1267	0.21	1442	0.31	1612	0.44	1770	0.58	1916	0.73
1625	1345	0.25	1506	0.35	1666	0.48	1818	0.62	1960	0.78
1750	1425	0.30	1573	0.40	1723	0.53	1868	0.67	2006	0.84
1875	1507	0.35	1644	0.46	1785	0.59	1923	0.73	2055	0.90
2000	1590	0.41	1718	0.52	1849	0.65	1980	0.80	2107	0.96
2125	1674	0.48	1794	0.59	1917	0.72	2041	0.87	2162	1.04
2250	1759	0.56	1871	0.67	1987	0.80	2104	0.95	2220	1.12
2375	1845	0.64	1951	0.76	2060	0.89	2170	1.05	2281	1.21
2500	1931	0.74	2031	0.86	2134	0.99	2239	1.15	2344	1.32

CFM	AVAILABLE EXTERNAL STATIC PRESSURE (in. wg)									
	1.2		1.4		1.6		1.8		2.0	
	rpm	bhp	rpm	bhp	rpm	bhp	rpm	bhp	rpm	bhp
1500	2051	0.90	2177	1.08	2295	1.26	2407	1.45	2514	1.66
1625	2092	0.95	2217	1.13	2334	1.32	2445	1.52	2551	1.72
1750	2136	1.01	2258	1.19	2374	1.38	2484	1.59	2588	1.79
1875	2182	1.07	2302	1.26	2415	1.45	2524	1.66	2628	1.87
2000	2230	1.14	2347	1.33	2459	1.53	2566	1.74	—	—
2125	2281	1.22	2395	1.41	2505	1.61	2609	1.82	—	—
2250	2334	1.30	2445	1.50	2552	1.70	2655	1.92	—	—
2375	2390	1.40	2497	1.59	2601	1.80	—	—	—	—
2500	2449	1.50	2552	1.70	2653	1.91	—	—	—	—

Standard/Medium Static 1267-2390 rpm, 1.44 maximum bhp

High Static 1267-2660 rpm, 1.96 maximum bhp

50FE-A06 Single Phase — Standard/Medium Static — 5 Ton Horizontal Supply (rpm - vdc)

CFM	AVAILABLE EXTERNAL STATIC PRESSURE (in. wg)									
	0.2		0.4		0.6		0.8		1.0	
	rpm	vdc	rpm	vdc	rpm	vdc	rpm	vdc	rpm	vdc
1500	1267	5.3	1442	6.0	1612	6.7	1770	7.4	1916	8.0
1625	1345	5.6	1506	6.3	1666	7.0	1818	7.6	1960	8.2
1750	1425	6.0	1574	6.6	1723	7.2	1869	7.8	2006	8.4
1875	1507	6.3	1644	6.9	1785	7.5	1923	8.0	2056	8.6
2000	1590	6.7	1719	7.2	1849	7.7	1980	8.3	2108	8.8
2125	1674	7.0	1794	7.5	1917	8.0	2041	8.5	2163	9.1
2250	1760	7.4	1872	7.8	1987	8.3	2104	8.8	2221	9.3
2375	1845	7.7	1951	8.2	2060	8.6	2171	9.1	2281	9.5
2500	1932	8.1	2032	8.5	2135	8.9	2239	9.4	2345	9.8

CFM	AVAILABLE EXTERNAL STATIC PRESSURE (in. wg)									
	1.2		1.4		1.6		1.8		2.0	
	rpm	vdc	rpm	vdc	rpm	vdc	rpm	vdc	rpm	vdc
1500	2051	8.6	2177	9.1	2296	9.6	—	—	—	—
1625	2093	8.8	2217	9.3	2334	9.8	—	—	—	—
1750	2136	8.9	2259	9.5	2374	9.9	—	—	—	—
1875	2182	9.1	2302	9.6	—	—	—	—	—	—
2000	2230	9.3	2347	9.8	—	—	—	—	—	—
2125	2281	9.5	—	—	—	—	—	—	—	—
2250	2334	9.8	—	—	—	—	—	—	—	—
2375	—	—	—	—	—	—	—	—	—	—
2500	—	—	—	—	—	—	—	—	—	—

Standard/Medium Static 1267-2390 rpm

50FE-A06 Single Phase — High Static — 5 Ton Horizontal Supply (rpm - vdc)

CFM	AVAILABLE EXTERNAL STATIC PRESSURE (in. wg)									
	0.2		0.4		0.6		0.8		1.0	
	rpm	vdc	rpm	vdc	rpm	vdc	rpm	vdc	rpm	vdc
1500	1267	4.8	1442	5.4	1612	6.1	1770	6.7	1916	7.2
1625	1345	5.1	1506	5.7	1666	6.3	1818	6.8	1960	7.4
1750	1425	5.4	1573	5.9	1723	6.5	1868	7.0	2006	7.5
1875	1507	5.7	1644	6.2	1785	6.7	1923	7.2	2055	7.7
2000	1590	6.0	1718	6.5	1849	7.0	1980	7.4	2107	7.9
2125	1674	6.3	1794	6.7	1917	7.2	2041	7.7	2162	8.1
2250	1759	6.6	1871	7.0	1987	7.5	2104	7.9	2220	8.3
2375	1845	6.9	1951	7.3	2060	7.7	2170	8.2	2281	8.6
2500	1931	7.3	2031	7.6	2134	8.0	2239	8.4	2344	8.8

CFM	AVAILABLE EXTERNAL STATIC PRESSURE (in. wg)									
	1.2		1.4		1.6		1.8		2.0	
	rpm	vdc	rpm	vdc	rpm	vdc	rpm	vdc	rpm	vdc
1500	2051	7.7	2177	8.2	2295	8.6	2407	9.0	2514	9.5
1625	2092	7.9	2217	8.3	2334	8.8	2445	9.2	2551	9.6
1750	2136	8.0	2258	8.5	2374	8.9	2484	9.3	2588	9.7
1875	2182	8.2	2302	8.7	2415	9.1	2524	9.5	2628	9.9
2000	2230	8.4	2347	8.8	2459	9.2	2566	9.6	—	—
2125	2281	8.6	2395	9.0	2505	9.4	2609	9.8	—	—
2250	2334	8.8	2445	9.2	2552	9.6	2655	10.0	—	—
2375	2390	9.0	2497	9.4	2601	9.8	—	—	—	—
2500	2449	9.2	2552	9.6	2653	10.0	—	—	—	—

High Static 1267-2660 rpm

50FE-A06 Three Phase — 5 Ton Horizontal Supply (rpm - bhp)

CFM	AVAILABLE EXTERNAL STATIC PRESSURE (in. wg)									
	0.2		0.4		0.6		0.8		1.0	
	rpm	bhp	rpm	bhp	rpm	bhp	rpm	bhp	rpm	bhp
1500	1267	0.21	1442	0.31	1612	0.44	1770	0.58	1916	0.73
1625	1345	0.25	1506	0.35	1666	0.48	1818	0.62	1960	0.78
1750	1425	0.30	1574	0.40	1723	0.53	1869	0.68	2006	0.84
1875	1507	0.35	1644	0.46	1785	0.59	1923	0.73	2056	0.90
2000	1590	0.41	1719	0.52	1849	0.65	1980	0.80	2108	0.96
2125	1674	0.48	1794	0.59	1917	0.72	2041	0.87	2163	1.04
2250	1760	0.56	1872	0.67	1987	0.80	2104	0.95	2221	1.12
2375	1845	0.64	1951	0.76	2060	0.89	2171	1.05	2281	1.21
2500	1932	0.74	2032	0.86	2135	0.99	2239	1.15	2345	1.32

CFM	AVAILABLE EXTERNAL STATIC PRESSURE (in. wg)									
	1.2		1.4		1.6		1.8		2.0	
	rpm	bhp	rpm	bhp	rpm	bhp	rpm	bhp	rpm	bhp
1500	2051	0.90	2177	1.08	2296	1.26	2408	1.46	2515	1.66
1625	2093	0.95	2217	1.13	2334	1.32	2445	1.52	2551	1.72
1750	2136	1.01	2259	1.19	2374	1.38	2484	1.59	2589	1.80
1875	2182	1.07	2302	1.26	2416	1.45	2524	1.66	2628	1.87
2000	2230	1.14	2347	1.33	2459	1.53	2566	1.74	2669	1.96
2125	2281	1.22	2395	1.41	2505	1.61	2610	1.83	2711	2.05
2250	2334	1.30	2445	1.50	2552	1.70	2655	1.92	2755	2.14
2375	2391	1.40	2498	1.59	2602	1.80	2702	2.02	2800	2.25
2500	2449	1.50	2552	1.70	2653	1.91	2752	2.13	—	—

Standard/Medium Static 1267-2390 rpm, 1.44 maximum bhp

High Static 1267-2836 rpm, 2.43 maximum bhp

50FE-A06 Three Phase — Standard/Medium Static — 5 Ton Horizontal Supply (rpm - vdc)

CFM	AVAILABLE EXTERNAL STATIC PRESSURE (in. wg)									
	0.2		0.4		0.6		0.8		1.0	
	rpm	vdc	rpm	vdc	rpm	vdc	rpm	vdc	rpm	vdc
1500	1267	5.3	1442	6.0	1612	6.7	1770	7.4	1916	8.0
1625	1345	5.6	1506	6.3	1666	7.0	1818	7.6	1960	8.2
1750	1425	6.0	1574	6.6	1723	7.2	1869	7.8	2006	8.4
1875	1507	6.3	1644	6.9	1785	7.5	1923	8.0	2056	8.6
2000	1590	6.7	1719	7.2	1849	7.7	1980	8.3	2108	8.8
2125	1674	7.0	1794	7.5	1917	8.0	2041	8.5	2163	9.1
2250	1760	7.4	1872	7.8	1987	8.3	2104	8.8	2221	9.3
2375	1845	7.7	1951	8.2	2060	8.6	2171	9.1	2281	9.5
2500	1932	8.1	2032	8.5	2135	8.9	2239	9.4	2345	9.8

CFM	AVAILABLE EXTERNAL STATIC PRESSURE (in. wg)									
	1.2		1.4		1.6		1.8		2.0	
	rpm	vdc	rpm	vdc	rpm	vdc	rpm	vdc	rpm	vdc
1500	2051	8.6	2177	9.1	2296	9.6	—	—	—	—
1625	2093	8.8	2217	9.3	2334	9.8	—	—	—	—
1750	2136	8.9	2259	9.5	2374	9.9	—	—	—	—
1875	2182	9.1	2302	9.6	—	—	—	—	—	—
2000	2230	9.3	2347	9.8	—	—	—	—	—	—
2125	2281	9.5	—	—	—	—	—	—	—	—
2250	2334	9.8	—	—	—	—	—	—	—	—
2375	—	—	—	—	—	—	—	—	—	—
2500	—	—	—	—	—	—	—	—	—	—

Standard/Medium Static 1267-2390 rpm

50FE-A06 Three Phase — High Static — 5 Ton Horizontal Supply (rpm - vdc)

CFM	AVAILABLE EXTERNAL STATIC PRESSURE (in. wg)									
	0.2		0.4		0.6		0.8		1.0	
	rpm	vdc	rpm	vdc	rpm	vdc	rpm	vdc	rpm	vdc
1500	1267	4.5	1442	5.1	1612	5.7	1770	6.2	1916	6.8
1625	1345	4.7	1506	5.3	1666	5.9	1818	6.4	1960	6.9
1750	1425	5.0	1574	5.6	1723	6.1	1869	6.6	2006	7.1
1875	1507	5.3	1644	5.8	1785	6.3	1923	6.8	2056	7.2
2000	1590	5.6	1719	6.1	1849	6.5	1980	7.0	2108	7.4
2125	1674	5.9	1794	6.3	1917	6.8	2041	7.2	2163	7.6
2250	1760	6.2	1872	6.6	1987	7.0	2104	7.4	2221	7.8
2375	1845	6.5	1951	6.9	2060	7.3	2171	7.7	2281	8.0
2500	1932	6.8	2032	7.2	2135	7.5	2239	7.9	2345	8.3

CFM	AVAILABLE EXTERNAL STATIC PRESSURE (in. wg)									
	1.2		1.4		1.6		1.8		2.0	
	rpm	vdc	rpm	vdc	rpm	vdc	rpm	vdc	rpm	vdc
1500	2051	7.2	2177	7.7	2296	8.1	2408	8.5	2515	8.9
1625	2093	7.4	2217	7.8	2334	8.2	2445	8.6	2551	9.0
1750	2136	7.5	2259	8.0	2374	8.4	2484	8.8	2589	9.1
1875	2182	7.7	2302	8.1	2416	8.5	2524	8.9	2628	9.3
2000	2230	7.9	2347	8.3	2459	8.7	2566	9.0	2669	9.4
2125	2281	8.0	2395	8.4	2505	8.8	2610	9.2	2711	9.6
2250	2334	8.2	2445	8.6	2552	9.0	2655	9.4	2755	9.7
2375	2391	8.4	2498	8.8	2602	9.2	2702	9.5	2800	9.9
2500	2449	8.6	2552	9.0	2653	9.4	2752	9.7	—	—

High Static 1267-2836 rpm

50FE-M07 Three Phase — 6 Ton Horizontal Supply (rpm - bhp)

CFM	AVAILABLE EXTERNAL STATIC PRESSURE (in. wg)									
	0.2		0.4		0.6		0.8		1.0	
	rpm	bhp	rpm	bhp	rpm	bhp	rpm	bhp	rpm	bhp
1800	1379	0.27	1512	0.35	1650	0.46	1786	0.58	1918	0.72
1950	1473	0.32	1594	0.41	1721	0.52	1848	0.64	1973	0.78
2100	1569	0.39	1680	0.48	1796	0.59	1915	0.71	2032	0.85
2250	1666	0.47	1769	0.56	1876	0.67	1986	0.79	2096	0.93
2400	1764	0.55	1860	0.65	1959	0.76	2061	0.88	2165	1.02
2550	1863	0.65	1952	0.75	2045	0.86	2140	0.99	2237	1.13
2700	1963	0.76	2047	0.86	2133	0.97	2222	1.10	2313	1.24
2850	2063	0.88	2142	0.99	2223	1.10	2307	1.23	2393	1.37
3000	2163	1.01	2238	1.12	2315	1.24	2394	1.37	2474	1.52

CFM	AVAILABLE EXTERNAL STATIC PRESSURE (in. wg)									
	1.2		1.4		1.6		1.8		2.0	
	rpm	bhp	rpm	bhp	rpm	bhp	rpm	bhp	rpm	bhp
1800	2044	0.87	2163	1.03	2276	1.20	2383	1.38	2486	1.57
1950	2094	0.93	2210	1.10	2320	1.27	2426	1.45	2527	1.64
2100	2148	1.00	2260	1.17	2367	1.34	2471	1.53	2570	1.72
2250	2206	1.08	2313	1.25	2417	1.43	2518	1.61	2616	1.81
2400	2268	1.18	2371	1.34	2471	1.52	2569	1.71	2664	1.90
2550	2335	1.28	2432	1.45	2528	1.62	2622	1.81	2715	2.01
2700	2405	1.40	2497	1.56	2589	1.74	2680	1.93	2769	2.13
2850	2479	1.53	2566	1.69	2654	1.87	2740	2.06	2826	2.26
3000	2556	1.67	2639	1.84	2722	2.02	2804	2.21	—	—

Standard/Medium Static 1379-2530 rpm, 1.76 maximum bhp

High Static 1379-2836 rpm, 2.43 maximum bhp

50FE-M07 Three Phase — Standard/Medium Static — 6 Ton Horizontal Supply (rpm - vdc)

CFM	AVAILABLE EXTERNAL STATIC PRESSURE (in. wg)									
	0.2		0.4		0.6		0.8		1.0	
	rpm	vdc	rpm	vdc	rpm	vdc	rpm	vdc	rpm	vdc
1800	1379	5.5	1512	6.0	1650	6.5	1786	7.1	1918	7.6
1950	1473	5.8	1594	6.3	1721	6.8	1848	7.3	1973	7.8
2100	1569	6.2	1680	6.6	1796	7.1	1915	7.6	2032	8.0
2250	1666	6.6	1769	7.0	1876	7.4	1986	7.8	2096	8.3
2400	1764	7.0	1860	7.4	1959	7.7	2061	8.1	2165	8.6
2550	1863	7.4	1952	7.7	2045	8.1	2140	8.5	2237	8.8
2700	1963	7.8	2047	8.1	2133	8.4	2222	8.8	2313	9.1
2850	2063	8.2	2142	8.5	2223	8.8	2307	9.1	2393	9.5
3000	2163	8.5	2238	8.8	2315	9.2	2394	9.5	2474	9.8

CFM	AVAILABLE EXTERNAL STATIC PRESSURE (in. wg)									
	1.2		1.4		1.6		1.8		2.0	
	rpm	vdc	rpm	vdc	rpm	vdc	rpm	vdc	rpm	vdc
1800	2044	8.1	2163	8.5	2276	9.0	2383	9.4	2486	9.8
1950	2094	8.3	2210	8.7	2320	9.2	2426	9.6	2527	10.0
2100	2148	8.5	2260	8.9	2367	9.4	2471	9.8	—	—
2250	2206	8.7	2313	9.1	2417	9.6	2518	10.0	—	—
2400	2268	9.0	2371	9.4	2471	9.8	—	—	—	—
2550	2335	9.2	2432	9.6	2528	10.0	—	—	—	—
2700	2405	9.5	2497	9.9	—	—	—	—	—	—
2850	2479	9.8	—	—	—	—	—	—	—	—
3000	—	—	—	—	—	—	—	—	—	—

Standard/Medium Static 1379-2530 rpm

50FE-M07 Three Phase — High Static — 6 Ton Horizontal Supply (rpm - vdc)

CFM	AVAILABLE EXTERNAL STATIC PRESSURE (in. wg)									
	0.2		0.4		0.6		0.8		1.0	
	rpm	vdc	rpm	vdc	rpm	vdc	rpm	vdc	rpm	vdc
1800	1379	4.9	1512	5.3	1650	5.8	1786	6.3	1918	6.8
1950	1473	5.2	1594	5.6	1721	6.1	1848	6.5	1973	7.0
2100	1569	5.5	1680	5.9	1796	6.3	1915	6.8	2032	7.2
2250	1666	5.9	1769	6.2	1876	6.6	1986	7.0	2096	7.4
2400	1764	6.2	1860	6.6	1959	6.9	2061	7.3	2165	7.6
2550	1863	6.6	1952	6.9	2045	7.2	2140	7.5	2237	7.9
2700	1963	6.9	2047	7.2	2133	7.5	2222	7.8	2313	8.2
2850	2063	7.3	2142	7.6	2223	7.8	2307	8.1	2393	8.4
3000	2163	7.6	2238	7.9	2315	8.2	2394	8.4	2474	8.7

CFM	AVAILABLE EXTERNAL STATIC PRESSURE (in. wg)									
	1.2		1.4		1.6		1.8		2.0	
	rpm	vdc	rpm	vdc	rpm	vdc	rpm	vdc	rpm	vdc
1800	2044	7.2	2163	7.6	2276	8.0	2383	8.4	2486	8.8
1950	2094	7.4	2210	7.8	2320	8.2	2426	8.6	2527	8.9
2100	2148	7.6	2260	8.0	2367	8.3	2471	8.7	2570	9.1
2250	2206	7.8	2313	8.2	2417	8.5	2518	8.9	2616	9.2
2400	2268	8.0	2371	8.4	2471	8.7	2569	9.1	2664	9.4
2550	2335	8.2	2432	8.6	2528	8.9	2622	9.2	2715	9.6
2700	2405	8.5	2497	8.8	2589	9.1	2680	9.4	2769	9.8
2850	2479	8.7	2566	9.0	2654	9.4	2740	9.7	2826	10.0
3000	2556	9.0	2639	9.3	2722	9.6	2804	9.9	—	—

High Static 1379-2836 rpm

Legend and Notes

Applicable for Electrical Data Tables on pages 102-119

LEGEND

BRKR	—	Circuit Breaker
CO	—	Convenience Outlet
FLA	—	Full Load Amps
IFM	—	Indoor Fan Motor
LRA	—	Locked Rotor Amps
MCA	—	Minimum Circuit Amps
PE	—	Power Exhaust
PWRD CO	—	Powered Convenience Outlet
RLA	—	Rated Load Amps
UNPWR CO	—	Unpowered Convenience Outlet

NOTES:

1. In compliance with NEC requirements for multi-motor and combination load equipment (refer to NEC Articles 430 and 440), the overcurrent protective device for the unit shall be fuse or HACR breaker. Canadian units may be fuse or circuit breaker.
2. For 208/230 v units, where one value is show it is the same for either 208 or 230 volts.
3. **Unbalanced 3-Phase Supply Voltage:** Never operate a motor where a phase imbalance in supply voltage is greater than 2%. Use the following formula to determine the percentage of voltage imbalance.

$$\% \text{ Voltage Imbalance} = 100 \times \frac{\text{max voltage deviation from average voltage}}{\text{average voltage}}$$

Example: Supply voltage is 230-3-60

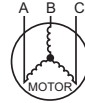

AB = 224-v
BC = 231-v
AC = 226-v

$$\text{Average Voltage} = \frac{(224 + 231 + 226)}{3} = \frac{681}{3} = 227$$

Determine maximum deviation from average voltage.

(AB) 227-224 = 3-v

(BC) 231-227 = 4-v

(AC) 227-226 = 1-v

Maximum deviation is 4-v.

Determine percent of voltage imbalance.

$$\% \text{ Voltage Imbalance} = 100 \times \frac{4}{227} = 1.76\%$$

This amount of phase imbalance is satisfactory as it is below the maximum allowable 2%.

IMPORTANT: If the supply voltage phase imbalance is more than 2%, contact your local electric utility company immediately.

48/50FE**04-07 Cooling Electrical Data^a

48/50FE UNIT	V-Ph-Hz	UNIT VOLTAGE		COMPRESSOR		OFM (ea)		STD SCCR kA	HIGH SCCR kA	IFM			COMBUSTION FAN MOTOR (48FE only)	POWER EXHAUST		
		Range		RLA	LRA	Watts	FLA			Type	Effcy at Full Load	FLA		FLA	Kit Qty	FLA (ea kit)
		Min	Max													
*A04	208-1-60	187	253	16.6	94	275	1.5	5	10	MED	84%	5.1	0.48	1	1.9	
										HIGH	85%	7.3				
	230-1-60	187	253	16.6	94	275	1.5	5	10	MED	84%	5.1	0.48	1	1.9	
										HIGH	85%	7.3				
	208-3-60	187	253	12.2	98	275	1.5	5	10	MED	84%	5.1	0.48	1	1.9	
										HIGH	85%	7.3				
	230-3-60	187	253	12.2	98	275	1.5	5	10	MED	84%	5.1	0.48	1	1.9	
										HIGH	85%	7.3				
	460-3-60	414	506	5.8	44	275	0.8	5	10	MED	85%	1.2	0.25	1	1.0	
										HIGH	84%	1.7				
	575-3-60	518	633	4.5	27	275	0.6	5	—	MED	84%	1.1	0.24	1	1.9	
										HIGH	85%	1.5				
*A05	208-1-60	187	253	22.4	126	275	1.5	5	10	MED	86%	7.1	0.48	1	1.9	
										HIGH	84%	9.2				
	230-1-60	187	253	22.4	126	275	1.5	5	10	MED	86%	7.1	0.48	1	1.9	
										HIGH	84%	9.2				
	208-3-60	187	253	13.4	120	275	1.5	5	10	MED	86%	7.1	0.48	1	1.9	
										HIGH	85%	5.5				
	230-3-60	187	253	13.4	120	275	1.5	5	10	MED	86%	7.1	0.48	1	1.9	
										HIGH	85%	5.5				
	460-3-60	414	506	6.0	49	275	0.8	5	10	MED	86%	1.7	0.25	1	1.0	
										HIGH	88%	2.6				
	575-3-60	518	633	5.8	41	275	0.6	5	—	MED	85%	1.5	0.24	1	1.9	
										HIGH	88%	2.3				
*A06	208-1-60	187	253	23.7	157	275	1.5	5	10	MED	84%	9.2	0.48	1	1.9	
										HIGH	87%	11.7				
	230-1-60	187	253	23.7	157	275	1.5	5	10	MED	84%	9.2	0.48	1	1.9	
										HIGH	87%	11.7				
	208-3-60	187	253	16.2	156	275	1.5	5	10	MED	84%	9.2	0.48	1	1.9	
										HIGH	84%	6.5				
	230-3-60	187	253	16.2	156	275	1.5	5	10	MED	84%	9.2	0.48	1	1.9	
										HIGH	84%	6.5				
	460-3-60	414	506	7.8	58	275	0.8	5	10	MED	86%	2.1	0.25	1	1.0	
										HIGH	88%	3.1				
	575-3-60	518	633	6.4	48	275	0.6	5	—	MED	85%	2.0	0.24	1	1.9	
										HIGH	87%	2.7				
*M07	208-3-60	187	253	18.9	162	275	1.5	5	10	MED	87%	5.5	0.48	1	1.9	
										HIGH	84%	6.5				
	230-3-60	187	253	18.9	162	275	1.5	5	10	MED	87%	5.5	0.48	1	1.9	
										HIGH	84%	6.5				
	460-3-60	414	506	9.6	71	275	0.8	5	10	MED	88%	2.6	0.25	1	1.0	
										HIGH	88%	3.1				
	575-3-60	518	633	6.6	58	275	0.6	5	—	MED	88%	2.3	0.24	1	1.9	
										HIGH	87%	2.7				

NOTE(S):

a. 48FE Ultra Low NOx units are not available for size 07 or 575-v.

48FE**04-07 MCA MOCP Electrical Data^a

48FE UNIT SIZE	NOM. V-Ph-Hz	IFM TYPE	STD SCCR KA	HIGH SCCR kA ^b	NO CONVENIENCE OUTLET OR UNPOWERED CONVENIENCE OUTLET							
					No Power Exhaust				With Power Exhaust (powered from unit)			
					MCA	Fuse or HACR Breaker	Disconnect Size		MCA	Fuse or HACR Breaker	Disconnect Size	
							FLA	LRA			FLA	LRA
*A04	208/230-1-60	MED	5	10	28	40	27	105	30	45	29	107
		HIGH	5	10	30	45	29	108	32	45	31	110
	208/230-3-60	MED	5	10	22	30	22	109	24	30	24	111
		HIGH	5	10	25	30	24	112	26	30	26	114
	460-3-60	MED	5	10	10	15	9	48	11	15	10	49
		HIGH	5	10	10	15	10	48	11	15	11	49
575-3-60	MED	5	—	8	15	7	31	10	15	9	33	
	HIGH	5	—	8	15	8	31	10	15	10	33	
*A05	208/230-1-60	MED	5	10	37	50	36	140	39	60	38	142
		HIGH	5	10	39	60	38	143	41	60	40	145
	208/230-3-60	MED	5	10	26	30	25	134	28	40	27	136
		HIGH	5	10	24	30	23	132	26	30	26	134
	460-3-60	MED	5	10	10	15	10	53	11	15	11	54
		HIGH	5	10	11	15	11	55	12	15	12	56
575-3-60	MED	5	—	10	15	9	45	12	15	11	47	
	HIGH	5	—	11	15	10	46	13	15	12	48	
*A06	208/230-1-60	MED	5	10	41	60	40	174	43	60	42	176
		HIGH	5	10	43	60	42	177	45	60	45	179
	208/230-3-60	MED	5	10	31	45	31	173	33	45	33	175
		HIGH	5	10	29	40	28	169	31	45	30	171
	460-3-60	MED	5	10	13	20	12	63	14	20	13	64
		HIGH	5	10	14	20	13	64	15	20	15	65
575-3-60	MED	5	—	11	15	10	53	13	15	13	55	
	HIGH	5	—	12	15	11	54	14	15	13	56	
*M07	208/230-3-60	MED	5	10	31	45	30	174	33	50	32	176
		HIGH	5	10	32	50	31	175	34	50	33	177
	460-3-60	MED	5	10	16	25	15	77	17	25	16	78
		HIGH	5	10	16	25	16	77	17	25	17	78
	575-3-60	MED	5	—	12	15	11	63	14	15	13	65
		HIGH	5	—	12	15	11	64	14	20	14	66

NOTE(S):

- a. 48FE Ultra Low NOx units are not available for size 07 or 575-v.
- b. High SCCR (Short Circuit Current Rating) is not available on the following: units with Humidi-MiZer system, Low Ambient controls, Phase loss monitor, Non-fused disconnect, and 575V models.

48FE**04-07 MCA MOCP Electrical Data (cont)^a

48FE UNIT SIZE	NOM. V-Ph-Hz	IFM TYPE	STD SCCR kA	WITH POWERED CONVENIENCE OUTLET							
				No Power Exhaust				With Power Exhaust (powered from unit)			
				MCA	Fuse or HACR Breaker	Disconnect Size		MCA	Fuse or HACR Breaker	Disconnect Size	
						FLA	LRA			FLA	LRA
*A04	208/230-3-60	MED	5	27	30	27	114	29	40	29	116
		HIGH	5	29	40	30	117	31	40	32	119
	460-3-60	MED	5	12	15	12	50	13	15	13	51
		HIGH	5	12	15	12	50	13	15	13	51
	575-3-60	MED	5	9	15	9	33	11	15	11	35
		HIGH	5	10	15	10	33	12	15	12	35
*A05	208/230-3-60	MED	5	31	40	31	139	33	45	33	141
		HIGH	5	29	40	29	137	31	40	31	139
	460-3-60	MED	5	13	15	12	55	14	15	13	56
		HIGH	5	14	15	13	57	15	20	14	58
	575-3-60	MED	5	12	15	11	47	13	15	13	49
		HIGH	5	12	15	12	48	14	20	14	50
*A06	208/230-3-60	MED	5	36	50	36	178	38	50	39	180
		HIGH	5	34	45	33	174	35	50	36	176
	460-3-60	MED	5	15	20	15	65	16	20	16	66
		HIGH	5	16	20	16	66	17	20	17	67
	575-3-60	MED	5	13	15	12	55	15	20	14	57
		HIGH	5	13	15	13	56	15	20	15	58
*M07	208/230-3-60	MED	5	36	50	35	179	38	50	37	181
		HIGH	5	37	50	36	180	39	50	39	182
	460-3-60	MED	5	18	25	17	79	19	25	19	80
		HIGH	5	19	25	18	79	20	25	19	80
	575-3-60	MED	5	13	15	13	65	15	20	15	67
		HIGH	5	14	15	13	66	16	20	16	68

NOTE(S):

a. 48FE Ultra Low NOx units are not available for size 07 or 575-v.

50FE-A04 MCA MOCPP Electrical Data

UNIT SIZE	NOM. V-Ph-Hz	IFM TYPE	STD SCCR kA	HIGH SCCR kA ^a	ELECTRIC HEATER			NO CONVENIENCE OUTLET OR UNPOWERED CONVENIENCE OUTLET								
					CRHEATER ***A00	NOM (kW)	FLA	No Power Exhaust				With Power Exhaust (powered from unit)				
								MCA	Fuse or HACR BRKR	Disconnect Size		MCA	Fuse or HACR BRKR	Disconnect Size		
										FLA	LRA			FLA	LRA	
50FE-A04	208/230-1-60	MED	5	10	—	—	—	28	40	27	105	30	45	29	107	
			5	10	323A	3.3/4.4	15.9/18.3	28/30	40/40	27/27	105/105	30/32	45/45	29/29	107/107	
			5	10	324A	4.9/6.5	23.5/27.1	36/41	40/45	33/37	105/105	39/43	45/45	35/39	107/107	
			5	10	325A	6.5/8.7	31.4/36.3	46/52	50/60	42/48	105/105	48/55	50/60	44/50	107/107	
			5	10	326A	7.9/10.5	37.9/43.8	54/62	60/70	49/56	105/105	57/64	60/70	52/58	107/107	
		5	10	327A	9.8/13.0	46.9/54.2	65/75	70/80	60/68	105/105	68/77	70/80	62/70	107/107		
		HIGH	5	10	—	—	—	30	45	29	108	32	45	31	110	
			5	10	323A	3.3/4.4	15.9/18.3	30/32	45/45	29/29	108/108	32/35	45/45	31/32	110/110	
			5	10	324A	4.9/6.5	23.5/27.1	39/43	45/45	35/40	108/108	41/46	45/50	38/42	110/110	
			5	10	325A	6.5/8.7	31.4/36.3	49/55	50/60	45/50	108/108	51/57	60/60	47/52	110/110	
			5	10	326A	7.9/10.5	37.9/43.8	57/64	60/70	52/59	108/108	59/67	60/70	54/61	110/110	
		5	10	327A	9.8/13.0	46.9/54.2	68/77	70/80	62/71	108/108	71/80	80/80	65/73	110/110		
	208/230-3-60	MED	5	10	—	—	—	22	30	22	109	24	30	24	111	
			5	10	323A	3.3/4.4	9.2/10.6	22/22	30/30	22/22	109/109	24/24	30/30	24/24	111/111	
			5	10	324A	4.9/6.5	13.6/15.6	24/26	30/30	22/24	109/109	26/29	30/30	24/26	111/111	
			5	10	325A	6.5/8.7	18.1/20.9	29/33	30/35	27/30	109/109	32/35	35/35	29/32	111/111	
			5	10	326A	7.9/10.5	21.9/25.3	34/38	35/40	31/35	109/109	37/41	40/45	33/37	111/111	
			5	10	328A	12.0/16.0	33.4/38.5	49/55	50/60	44/50	109/109	51/57	60/60	46/52	111/111	
		HIGH	5	10	—	—	—	25	30	24	112	26	30	26	114	
			5	10	323A	3.3/4.4	9.2/10.6	25/25	30/30	24/24	112/112	26/26	30/30	26/26	114/114	
			5	10	324A	4.9/6.5	13.6/15.6	27/29	30/30	24/26	112/112	29/31	30/35	26/29	114/114	
			5	10	325A	6.5/8.7	18.1/20.9	32/36	35/40	29/32	112/112	35/38	35/40	31/35	114/114	
			5	10	326A	7.9/10.5	21.9/25.3	37/41	40/45	34/37	112/112	39/44	40/45	36/40	114/114	
			5	10	328A	12.0/16.0	33.4/38.5	51/58	60/60	47/53	112/112	54/60	60/60	49/55	114/114	
	460-3-60	MED	5	10	—	—	—	10	15	9	48	11	15	10	49	
			5	10	333A	6.0	7.2	11	15	10	48	12	15	11	49	
			5	10	334A	8.8	10.6	15	15	14	48	16	20	15	49	
			5	10	335A	11.5	13.8	19	20	17	48	20	25	18	49	
			5	10	336A	14.0	16.8	23	25	21	48	24	25	22	49	
		HIGH	5	10	—	—	—	10	15	10	48	11	15	11	49	
			5	10	333A	6.0	7.2	12	15	10	48	13	15	11	49	
			5	10	334A	8.8	10.6	16	20	14	48	17	20	15	49	
			5	10	335A	11.5	13.8	20	20	18	48	21	25	19	49	
			5	10	336A	14.0	16.8	24	25	21	48	25	25	22	49	
		575-3-60	MED	5	—	—	—	—	8	15	7	31	10	15	9	33
				5	—	339A	10.0	9.6	14	15	12	31	16	20	14	33
5	—			340A	15.0	14.4	20	20	18	31	22	25	20	33		
HIGH	5		—	—	—	—	8	15	8	31	10	15	10	33		
	5		—	339A	10.0	9.6	14	15	13	31	17	20	15	33		
5	—	340A	15.0	14.4	20	20	18	31	23	25	20	33				

NOTE(S):

- a. High SCCR (Short Circuit Current Rating) is not available on the following: units with Humidi-MiZer system, Low Ambient controls, Phase loss monitor, Non-fused disconnect, and 575V models.

50FE-A04 MCA MOCOP Electrical Data (cont)

UNIT SIZE	NOM. V-Ph-Hz	IFM TYPE	STD SCCR kA	ELECTRIC HEATER			WITH POWERED CONVENIENCE OUTLET									
				CRHEATER ***A00	NOM (kW)	FLA	No Power Exhaust				With Power Exhaust (powered from unit)					
							MCA	Fuse or HACR BRKR	Disconnect Size		MCA	Fuse or HACR BRKR	Disconnect Size			
									FLA	LRA			FLA	LRA		
50FE-A04	208/230-3-60	MED	5	—	—	—	27	30	27	114	29	40	29	116		
			5	323A	3.3/4.4	9.2/10.6	27/27	30/30	27/27	114/114	29/29	40/40	29/29	116/116		
			5	324A	4.9/6.5	13.6/15.6	30/32	30/35	27/29	114/114	32/35	40/40	29/32	116/116		
			5	325A	6.5/8.7	18.1/20.9	35/39	40/40	32/35	114/114	38/41	40/45	34/38	116/116		
			5	326A	7.9/10.5	21.9/25.3	40/44	40/45	37/40	114/114	43/47	45/50	39/43	116/116		
			5	328A	12.0/16.0	33.4/38.5	55/61	60/70	50/56	114/114	57/63	60/70	52/58	116/116		
		HIGH	5	—	—	—	29	40	30	117	31	40	32	119		
			5	323A	3.3/4.4	9.2/10.6	29/29	40/40	30/30	117/117	31/31	40/40	32/32	119/119		
			5	324A	4.9/6.5	13.6/15.6	33/35	40/40	30/32	117/117	35/37	40/40	32/34	119/119		
			5	325A	6.5/8.7	18.1/20.9	38/42	40/45	35/38	117/117	41/44	45/45	37/40	119/119		
			5	326A	7.9/10.5	21.9/25.3	43/47	45/50	39/43	117/117	45/50	45/50	41/45	119/119		
			5	328A	12.0/16.0	33.4/38.5	57/64	60/70	52/58	117/117	60/66	60/70	55/60	119/119		
			460-3-60	MED	5	—	—	—	12	15	12	50	13	15	13	51
					5	333A	6.0	7.2	14	15	12	50	15	15	13	51
	5	334A			8.8	10.6	18	20	16	50	19	20	17	51		
	5	335A			11.5	13.8	22	25	20	50	23	25	21	51		
	HIGH	5		336A	14.0	16.8	26	30	23	50	27	30	24	51		
		5		—	—	—	12	15	12	50	13	15	13	51		
		5		333A	6.0	7.2	14	15	13	50	16	20	14	51		
		5		334A	8.8	10.6	19	20	17	50	20	20	18	51		
	575-3-60	MED	5	335A	11.5	13.8	23	25	20	50	24	25	22	51		
			5	336A	14.0	16.8	26	30	24	50	28	30	25	51		
			5	—	—	—	9	15	9	33	11	15	11	35		
		HIGH	5	339A	10.0	9.6	16	20	14	33	18	20	16	35		
			5	340A	15.0	14.4	22	25	20	33	24	25	22	35		
			5	—	—	—	10	15	10	33	12	15	12	35		
	5	339A	10.0	9.6	16	20	15	33	19	20	17	35				
	5	340A	15.0	14.4	22	25	20	33	25	25	22	35				

50FE-A05 MCA MOCP Electrical Data

UNIT SIZE	NOM. V-Ph-Hz	IFM TYPE	STD SCCR kA	HIGH SCCR kA ^a	ELECTRIC HEATER			NO CONVENIENCE OUTLET OR UNPOWERED CONVENIENCE OUTLET							
					CRHEATER ***A00	NOM (kW)	FLA	No Power Exhaust				With Power Exhaust (powered from unit)			
								MCA	Fuse or HACR BRKR	Disconnect Size		MCA	Fuse or HACR BRKR	Disconnect Size	
										FLA	LRA			FLA	LRA
50FE-A05	208/230-1-60	MED	5	10	—	—	—	37	50	36	140	39	60	38	142
			5	10	323A	3.3/4.4	15.9/18.3	37/37	50/50	36/36	140/140	39/39	60/60	38/38	142/142
			5	10	325A	6.5/8.7	31.4/36.3	49/55	50/60	44/50	140/140	51/57	60/60	46/52	142/142
			5	10	327A	9.8/13.0	46.9/54.2	68/77	70/80	62/70	140/140	70/79	70/80	64/73	142/142
			5	10	329A	13.1/17.4	62.8/72.5	88/100	90/100	80/92	140/140	90/102	90/110	83/94	142/142
			5	10	330A	14.4/19.2	69.3/80.0	96/109	100/110	88/100	140/140	98/112	100/125	90/102	142/142
		5	10	331A	15.8/21.0	75.8/87.5	104/119	110/125	95/109	140/140	106/121	110/125	98/111	142/142	
		5	10	—	—	—	39	60	38	143	41	60	40	145	
		5	10	323A	3.3/4.4	15.9/18.3	39/39	60/60	38/38	143/143	41/41	60/60	40/40	145/145	
		5	10	325A	6.5/8.7	31.4/36.3	51/57	60/60	47/52	143/143	54/60	60/60	49/55	145/145	
		5	10	327A	9.8/13.0	46.9/54.2	71/80	80/80	65/73	143/143	73/82	80/90	67/75	145/145	
		5	10	329A	13.1/17.4	62.8/72.5	90/103	100/110	83/94	143/143	93/105	100/110	85/96	145/145	
	5	10	330A	14.4/19.2	69.3/80.0	99/112	100/125	90/103	143/143	101/114	110/125	92/105	145/145		
	5	10	331A	15.8/21.0	75.8/87.5	107/121	110/125	98/111	143/143	109/124	110/125	100/113	145/145		
	5	10	—	—	—	26	30	25	134	28	40	27	136		
	5	10	323A	3.3/4.4	9.2/10.6	26/26	30/30	25/25	134/134	28/28	40/40	27/27	136/136		
	5	10	324A	4.9/6.5	13.6/15.6	26/29	30/30	25/26	134/134	29/31	40/40	27/28	136/136		
	5	10	325A	6.5/8.7	18.1/20.9	32/35	35/35	29/32	134/134	34/38	40/40	31/34	136/136		
	5	10	328A	12.0/16.0	33.4/38.5	51/57	60/60	47/52	134/134	53/60	60/60	49/55	136/136		
	5	10	330A	14.4/19.2	40.0/46.2	59/67	60/70	54/61	134/134	62/69	70/70	56/63	136/136		
	5	10	331A	15.8/21.0	43.8/50.5	64/72	70/80	59/66	134/134	66/75	70/80	61/68	136/136		
	5	10	—	—	—	24	30	23	132	26	30	26	134		
	5	10	323A	3.3/4.4	9.2/10.6	24/24	30/30	23/23	132/132	26/26	30/30	26/26	134/134		
	5	10	324A	4.9/6.5	13.6/15.6	24/27	30/30	23/24	132/132	27/29	30/30	26/26	134/134		
	5	10	325A	6.5/8.7	18.1/20.9	30/33	30/35	27/30	132/132	32/36	35/40	29/33	134/134		
	5	10	328A	12.0/16.0	33.4/38.5	49/55	50/60	45/51	132/132	51/58	60/60	47/53	134/134		
	5	10	330A	14.4/19.2	40.0/46.2	57/65	60/70	52/59	132/132	60/67	60/70	55/62	134/134		
	5	10	331A	15.8/21.0	43.8/50.5	62/70	70/80	57/64	132/132	64/73	70/80	59/67	134/134		
	5	10	—	—	—	10	15	10	53	11	15	11	54		
	5	10	333A	6.0	7.2	12	15	10	53	13	15	11	54		
	5	10	335A	11.5	13.8	20	20	18	53	21	25	19	54		
	5	10	336A	14.0	16.8	24	25	21	53	25	25	22	54		
	5	10	337A	21.5	25.9	35	35	32	53	36	40	33	54		
	5	10	—	—	—	11	15	11	55	12	15	12	56		
	5	10	333A	6.0	7.2	13	15	11	55	14	15	12	56		
	5	10	335A	11.5	13.8	21	25	19	55	22	25	20	56		
	5	10	336A	14.0	16.8	25	25	22	55	26	30	23	56		
	5	10	337A	21.5	25.9	36	40	33	55	37	40	34	56		
	5	—	—	—	—	10	15	9	45	12	15	11	47		
	5	—	339A	10.0	9.6	14	15	13	45	17	20	15	47		
	5	—	340A	15.0	14.4	20	20	18	45	23	25	20	47		
	5	—	—	—	—	11	15	10	46	13	15	12	48		
5	—	339A	10.0	9.6	15	15	14	46	18	20	16	48			
5	—	340A	15.0	14.4	21	25	19	46	24	25	21	48			

NOTE(S):

- a. High SCCR (Short Circuit Current Rating) is not available on the following: units with Humidi-MiZer system, Low Ambient controls, Phase loss monitor, Non-fused disconnect, and 575V models.

50FE-A05 MCA MOCOP Electrical Data (cont)

UNIT SIZE	NOM. V-Ph-Hz	IFM TYPE	STD SCCR kA	ELECTRIC HEATER			WITH POWERED CONVENIENCE OUTLET							
				CRHEATER ***A00	NOM (kW)	FLA	No Power Exhaust				With Power Exhaust (powered from unit)			
							MCA	Fuse or HACR BRKR	Disconnect Size		MCA	Fuse or HACR BRKR	Disconnect Size	
									FLA	LRA			FLA	LRA
50FE-A05	208/230-3-60	MED	5	—	—	—	31	40	31	139	33	45	33	141
			5	323A	3.3/4.4	9.2/10.6	31/31	40/40	31/31	139/139	33/33	45/45	33/33	141/141
			5	324A	4.9/6.5	13.6/15.6	32/35	40/40	31/32	139/139	35/37	45/45	33/34	141/141
			5	325A	6.5/8.7	18.1/20.9	38/41	40/45	35/38	139/139	40/44	45/45	37/40	141/141
			5	328A	12.0/16.0	33.4/38.5	57/63	60/70	52/58	139/139	59/66	60/70	54/60	141/141
			5	330A	14.4/19.2	40.0/46.2	65/73	70/80	60/67	139/139	68/75	70/80	62/69	141/141
		5	331A	15.8/21.0	43.8/50.5	70/78	70/80	64/72	139/139	72/81	80/90	66/74	141/141	
		5	—	—	—	29	40	29	137	31	40	31	139	
		5	323A	3.3/4.4	9.2/10.6	29/29	40/40	29/29	137/137	31/31	40/40	31/31	139/139	
		5	324A	4.9/6.5	13.6/15.6	30/33	40/40	29/30	137/137	33/35	40/40	31/32	139/139	
		5	325A	6.5/8.7	18.1/20.9	36/39	40/40	33/36	137/137	38/42	40/45	35/38	139/139	
		5	328A	12.0/16.0	33.4/38.5	55/61	60/70	50/56	137/137	57/64	60/70	52/58	139/139	
	5	330A	14.4/19.2	40.0/46.2	63/71	70/80	58/65	137/137	66/73	70/80	60/67	139/139		
	5	331A	15.8/21.0	43.8/50.5	68/76	70/80	62/70	137/137	70/79	80/80	64/72	139/139		
	5	—	—	—	13	15	12	55	14	15	13	56		
	5	333A	6.0	7.2	14	15	13	55	16	20	14	56		
	5	335A	11.5	13.8	23	25	20	55	24	25	22	56		
	5	336A	14.0	16.8	26	30	24	55	28	30	25	56		
	5	337A	21.5	25.9	38	40	34	55	39	40	35	56		
	5	—	—	—	14	15	13	57	15	20	14	58		
	5	333A	6.0	7.2	15	15	14	57	17	20	15	58		
	5	335A	11.5	13.8	24	25	21	57	25	25	23	58		
	5	336A	14.0	16.8	27	30	25	57	29	30	26	58		
	5	337A	21.5	25.9	39	40	35	57	40	40	36	58		
	5	—	—	—	12	15	11	47	13	15	13	49		
	5	339A	10.0	9.6	16	20	15	47	19	20	17	49		
	5	340A	15.0	14.4	22	25	20	47	25	25	22	49		
	5	—	—	—	12	15	12	48	14	20	14	50		
	5	339A	10.0	9.6	17	20	16	48	20	20	18	50		
	5	340A	15.0	14.4	23	25	21	48	26	30	23	50		

50FE-A06 MCA MOCPElectrical Data

UNIT SIZE	NOM. V-Ph-Hz	IFM TYPE	STD SCCR kA	HIGH SCCR kA ^a	ELECTRIC HEATER			NO CONVENIENCE OUTLET OR UNPOWERED CONVENIENCE OUTLET							
					CRHEATER ***A00	NOM (kW)	FLA	No Power Exhaust				With Power Exhaust (powered from unit)			
								MCA	Fuse or HACR BRKR	Disconnect Size		MCA	Fuse or HACR BRKR	Disconnect Size	
										FLA	LRA			FLA	LRA
50FE-A06	208/230-1-60	MED	5	10	—	—	—	41	60	40	174	43	60	42	176
			5	10	324A	4.9/6.5	23.5/27.1	41/46	60/60	40/42	174/174	44/48	60/60	42/44	176/176
			5	10	325A	6.5/8.7	31.4/36.3	51/57	60/60	47/52	174/174	54/60	60/60	49/55	176/176
			5	10	327A	9.8/13.0	46.9/54.2	71/80	80/80	65/73	174/174	73/82	80/90	67/75	176/176
			5	10	329A	13.1/17.4	62.8/72.5	90/103	100/110	83/94	174/174	93/105	100/110	85/96	176/176
		5	10	331A	15.8/21.0	75.8/87.5	107/121	110/125	98/111	174/174	109/124	110/125	100/113	176/176	
		HIGH	5	10	—	—	—	43	60	42	177	45	60	45	179
			5	10	324A	4.9/6.5	23.5/27.1	44/49	60/60	42/45	177/177	47/51	60/60	45/47	179/179
			5	10	325A	6.5/8.7	31.4/36.3	54/60	60/60	50/55	177/177	57/63	60/70	52/57	179/179
			5	10	327A	9.8/13.0	46.9/54.2	74/83	80/90	67/76	177/177	76/85	80/90	70/78	179/179
			5	10	329A	13.1/17.4	62.8/72.5	94/106	100/110	86/97	177/177	96/108	100/110	88/99	179/179
		5	10	331A	15.8/21.0	75.8/87.5	110/124	110/125	101/114	177/177	112/127	125/150	103/116	179/179	
	208/230-3-60	MED	5	10	—	—	—	31	45	31	173	33	45	33	175
			5	10	324A	4.9/6.5	13.6/15.6	31/31	45/45	31/31	173/173	33/34	45/45	33/33	175/175
			5	10	326A	7.9/10.5	21.9/25.3	39/44	45/45	36/40	173/173	42/46	45/50	38/42	175/175
			5	10	328A	12.0/16.0	33.4/38.5	54/60	60/60	49/55	173/173	56/62	60/70	51/57	175/175
			5	10	331A	15.8/21.0	43.8/50.5	67/75	70/80	61/69	173/173	69/77	70/80	63/71	175/175
		5	10	332A	18.4/24.5	51.1/58.9	76/86	80/90	69/78	173/173	78/88	80/90	72/81	175/175	
		HIGH	5	10	—	—	—	29	40	28	169	31	45	30	171
			5	10	324A	4.9/6.5	13.6/15.6	29/29	40/40	28/28	169/169	31/31	45/45	30/30	171/171
			5	10	326A	7.9/10.5	21.9/25.3	36/40	40/40	33/37	169/169	38/43	45/45	35/39	171/171
			5	10	328A	12.0/16.0	33.4/38.5	50/57	50/60	46/52	169/169	53/59	60/60	48/54	171/171
			5	10	331A	15.8/21.0	43.8/50.5	63/72	70/80	58/66	169/169	66/74	70/80	60/68	171/171
		5	10	332A	18.4/24.5	51.1/58.9	72/82	80/90	66/75	169/169	75/85	80/90	68/77	171/171	
	460-3-60	MED	5	10	—	—	—	13	20	12	63	14	20	13	64
			5	10	333A	6.0	7.2	13	20	12	63	14	20	13	64
			5	10	335A	11.5	13.8	20	20	18	63	22	25	19	64
			5	10	336A	14.0	16.8	24	25	22	63	25	25	23	64
			5	10	337A	21.5	25.9	35	40	32	63	37	40	33	64
		5	10	338A	24.0	28.9	39	40	36	63	40	45	37	64	
		HIGH	5	10	—	—	—	14	20	13	64	15	20	15	65
			5	10	333A	6.0	7.2	14	20	13	64	15	20	15	65
			5	10	335A	11.5	13.8	22	25	19	64	23	25	21	65
			5	10	336A	14.0	16.8	25	25	23	64	27	30	24	65
			5	10	337A	21.5	25.9	37	40	33	64	38	40	35	65
		5	10	338A	24.0	28.9	40	45	37	64	42	45	38	65	
575-3-60	MED	5	—	—	—	—	11	15	10	53	13	15	13	55	
		5	—	340A	15.0	14.4	21	25	19	53	23	25	21	55	
		5	—	341A	21.0	20.2	28	30	26	53	31	35	28	55	
	HIGH	5	—	—	—	—	12	15	11	54	14	15	13	56	
		5	—	340A	15.0	14.4	22	25	20	54	24	25	22	56	
5	—	341A	21.0	20.2	29	30	26	54	31	35	29	56			

NOTE(S):

- High SCCR (Short Circuit Current Rating) is not available on the following: units with Humidi-MiZer system, Low Ambient controls, Phase loss monitor, Non-fused disconnect, and 575V models.

50FE-A06 MCA MOCOP Electrical Data (cont)

UNIT SIZE	NOM. V-Ph-Hz	IFM TYPE	STD SCCR kA	ELECTRIC HEATER			WITH POWERED CONVENIENCE OUTLET									
				CRHEATER ***A00	NOM (kW)	FLA	No Power Exhaust				With Power Exhaust (powered from unit)					
							MCA	Fuse or HACR BRKR	Disconnect Size		MCA	Fuse or HACR BRKR	Disconnect Size			
									FLA	LRA			FLA	LRA		
50FE-A06	208/230-3-60	MED	5	—	—	—	36	50	36	178	38	50	39	180		
			5	324A	4.9/6.5	13.6/15.6	36/37	50/50	36/36	178/178	38/40	50/50	39/39	180/180		
			5	326A	7.9/10.5	21.9/25.3	45/50	50/50	41/45	178/178	48/52	50/60	43/47	180/180		
			5	328A	12.0/16.0	33.4/38.5	60/66	60/70	55/60	178/178	62/68	70/70	57/63	180/180		
			5	331A	15.8/21.0	43.8/50.5	73/81	80/90	66/74	178/178	75/83	80/90	69/76	180/180		
			5	332A	18.4/24.5	51.1/58.9	82/92	90/100	75/84	178/178	84/94	90/100	77/86	180/180		
		HIGH	5	—	—	—	—	34	45	33	174	35	50	36	176	
			5	324A	4.9/6.5	13.6/15.6	34/34	45/45	33/33	174/174	35/36	50/50	36/36	176/176		
			5	326A	7.9/10.5	21.9/25.3	42/46	45/50	38/42	174/174	44/49	50/50	40/44	176/176		
			5	328A	12.0/16.0	33.4/38.5	56/63	60/70	51/57	174/174	59/65	60/70	54/59	176/176		
			5	331A	15.8/21.0	43.8/50.5	69/78	70/80	63/71	174/174	72/80	80/80	66/73	176/176		
			5	332A	18.4/24.5	51.1/58.9	78/88	80/90	72/81	174/174	81/91	90/100	74/83	176/176		
			460-3-60	MED	5	—	—	—	15	20	15	65	16	20	16	66
					5	333A	6.0	7.2	15	20	15	65	16	20	16	66
	5	335A			11.5	13.8	23	25	21	65	24	25	22	66		
	5	336A			14.0	16.8	27	30	24	65	28	30	25	66		
	5	337A			21.5	25.9	38	40	35	65	39	40	36	66		
	5	338A			24.0	28.9	42	45	38	65	43	45	39	66		
	HIGH	5		—	—	—	—	16	20	16	66	17	20	17	67	
		5		333A	6.0	7.2	16	20	16	66	17	20	17	67		
		5		335A	11.5	13.8	24	25	22	66	26	30	23	67		
		5		336A	14.0	16.8	28	30	25	66	29	30	27	67		
	575-3-60	MED	5	—	—	—	13	15	12	55	15	20	14	57		
			5	340A	15.0	14.4	23	25	21	55	25	30	23	57		
			5	341A	21.0	20.2	30	30	27	55	33	35	30	57		
			5	—	—	—	—	13	15	13	56	15	20	15	58	
			5	340A	15.0	14.4	24	25	22	56	26	30	24	58		
			5	341A	21.0	20.2	31	35	28	56	34	35	30	58		

50FE-M07 MCA MOCP Electrical Data

UNIT SIZE	NOM. V-Ph-Hz	IFM TYPE	STD SCCR kA	HIGH SCCR kA ^a	ELECTRIC HEATER			NO CONVENIENCE OUTLET OR UNPOWERED CONVENIENCE OUTLET								
					CRHEATER ***A00	NOM (kW)	FLA	No Power Exhaust				With Power Exhaust (powered from unit)				
								MCA	Fuse or HACR BRKR	Disconnect Size		MCA	Fuse or HACR BRKR	Disconnect Size		
										FLA	LRA			FLA	LRA	
50FE-M07	208/230-3-60	MED	5	10	—	—	—	31	45	30	174	33	50	32	176	
			5	10	324A	4.9/6.5	13.6/15.6	31/31	45/45	30/30	174/174	33/33	50/50	32/32	176/176	
			5	10	326A	7.9/10.5	21.9/25.3	35/39	45/45	32/35	174/174	37/41	50/50	34/38	176/176	
			5	10	328A	12.0/16.0	33.4/38.5	49/55	50/60	45/51	174/174	51/58	60/60	47/53	176/176	
			5	10	331A	15.8/21.0	43.8/50.5	62/70	70/80	57/64	174/174	64/73	70/80	59/67	176/176	
		5	10	332A	18.4/24.5	51.1/58.9	71/81	80/90	65/74	174/174	74/83	80/90	67/76	176/176		
		HIGH	5	10	—	—	—	32	50	31	175	34	50	33	177	
			5	10	324A	4.9/6.5	13.6/15.6	32/32	50/50	31/31	175/175	34/34	50/50	33/33	177/177	
			5	10	326A	7.9/10.5	21.9/25.3	36/40	50/50	33/37	175/175	38/43	50/50	35/39	177/177	
			5	10	328A	12.0/16.0	33.4/38.5	50/57	50/60	46/52	175/175	53/59	60/60	48/54	177/177	
			5	10	331A	15.8/21.0	43.8/50.5	63/72	70/80	58/66	175/175	66/74	70/80	60/68	177/177	
		5	10	332A	18.4/24.5	51.1/58.9	72/82	80/90	66/75	175/175	75/85	80/90	68/77	177/177		
		460-3-60	MED	5	10	—	—	—	16	25	15	77	17	25	16	78
				5	10	333A	6.0	7.2	16	25	15	77	17	25	16	78
	5			10	335A	11.5	13.8	21	25	19	77	22	25	20	78	
	5			10	336A	14.0	16.8	25	25	22	77	26	30	23	78	
	5			10	337A	21.5	25.9	36	40	33	77	37	40	34	78	
	5		10	338A	24.0	28.9	40	40	36	77	41	45	37	78		
	HIGH		5	10	—	—	—	16	25	16	77	17	25	17	78	
			5	10	333A	6.0	7.2	16	25	16	77	17	25	17	78	
			5	10	335A	11.5	13.8	22	25	19	77	23	25	21	78	
			5	10	336A	14.0	16.8	25	25	23	77	27	30	24	78	
			5	10	337A	21.5	25.9	37	40	33	77	38	40	35	78	
	5		10	338A	24.0	28.9	40	45	37	77	42	45	38	78		
	575-3-60		MED	5	—	—	—	—	12	15	11	63	14	15	13	65
				5	—	340A	15.0	14.4	21	25	19	63	24	25	21	65
		5		—	341A	21.0	20.2	29	30	26	63	31	35	28	65	
		HIGH	5	—	—	—	—	—	12	15	11	64	14	20	14	66
5			—	340A	15.0	14.4	22	25	20	64	24	25	22	66		
5			—	341A	21.0	20.2	29	30	26	64	31	35	29	66		
5			—	341A	21.0	20.2	29	30	26	64	31	35	29	66		

NOTE(S):

- a. High SCCR (Short Circuit Current Rating) is not available on the following: units with Humidi-MiZer system, Low Ambient controls, Phase loss monitor, Non-fused disconnect, and 575V models.

50FE-M07 MCA MOCP Electrical Data (cont)

UNIT SIZE	NOM. V-Ph-Hz	IFM TYPE	STD SCCR kA	ELECTRIC HEATER			WITH POWERED CONVENIENCE OUTLET								
				CRHEATER ***A00	NOM (kW)	FLA	No Power Exhaust				With Power Exhaust (powered from unit)				
							MCA	Fuse or HACR BRKR	Disconnect Size		MCA	Fuse or HACR BRKR	Disconnect Size		
									FLA	LRA			FLA	LRA	
50FE-M07	208/230-3-60	MED	5	—	—	—	36	50	35	179	38	50	37	181	
			5	324A	4.9/6.5	13.6/15.6	36/36	50/50	35/35	179/179	38/38	50/50	37/37	181/181	
			5	326A	7.9/10.5	21.9/25.3	41/45	50/50	37/41	179/179	43/47	50/50	39/43	181/181	
			5	328A	12.0/16.0	33.4/38.5	55/61	60/70	50/56	179/179	57/64	60/70	52/58	181/181	
			5	331A	15.8/21.0	43.8/50.5	68/76	70/80	62/70	179/179	70/79	80/80	64/72	181/181	
		5	332A	18.4/24.5	51.1/58.9	77/87	80/90	71/80	179/179	80/89	80/90	73/82	181/181		
		HIGH	5	—	—	—	37	50	36	180	39	50	39	182	
			5	324A	4.9/6.5	13.6/15.6	37/37	50/50	36/36	180/180	39/39	50/50	39/39	182/182	
			5	326A	7.9/10.5	21.9/25.3	42/46	50/50	38/42	180/180	44/49	50/50	40/44	182/182	
			5	328A	12.0/16.0	33.4/38.5	56/63	60/70	51/57	180/180	59/65	60/70	54/59	182/182	
			5	331A	15.8/21.0	43.8/50.5	69/78	70/80	63/71	180/180	72/80	80/80	66/73	182/182	
		5	332A	18.4/24.5	51.1/58.9	78/88	80/90	72/81	180/180	81/91	90/100	74/83	182/182		
		460-3-60	MED	5	—	—	—	18	25	17	79	19	25	19	80
				5	333A	6.0	7.2	18	25	17	79	19	25	19	80
	5			335A	11.5	13.8	24	25	21	79	25	25	23	80	
	5			336A	14.0	16.8	27	30	25	79	29	30	26	80	
	5			337A	21.5	25.9	39	40	35	79	40	40	36	80	
	5		338A	24.0	28.9	43	45	39	79	44	45	40	80		
	HIGH		5	—	—	—	19	25	18	79	20	25	19	80	
			5	333A	6.0	7.2	19	25	18	79	20	25	19	80	
			5	335A	11.5	13.8	24	25	22	79	26	30	23	80	
			5	336A	14.0	16.8	28	30	25	79	29	30	27	80	
			5	337A	21.5	25.9	39	40	36	79	41	45	37	80	
	5		338A	24.0	28.9	43	45	39	79	44	45	40	80		
	575-3-60		MED	5	—	—	—	13	15	13	65	15	20	15	67
				5	340A	15.0	14.4	23	25	21	65	26	30	23	67
		5	341A	21.0	20.2	31	35	28	65	33	35	30	67		
		HIGH	5	—	—	—	14	15	13	66	16	20	16	68	
5			340A	15.0	14.4	24	25	22	66	26	30	24	68		
5	341A	21.0	20.2	31	35	28	66	34	35	30	68				

50FE-A04 1-Phase Electric Heat Data — Without Non-Fused Disconnect

50FE UNIT SIZE	NOM. V-Ph-Hz	IFM TYPE	ELECTRIC HEATER PART NUMBER	NOM (kW)	APPLICATION (kW)	APPLICATION OUTPUT (MBH)	SINGLE POINT OR JUNCTION PART NUMBER CRSINGLEXXA00			
							No CO or Unpowered CO		With PWRD CO	
							No PE	With PE (pwrd fr/unit)	No PE	With PE (pwrd fr/unit)
-A04	208/230-1-60	MED	CRHEATER323A00	4.4	3.3/4.0	11.3/13.8	—	—	—	—
			CRHEATER324A00	6.5	4.9/6.0	16.7/20.4	—	—	—	—
			CRHEATER325A00	8.7	6.5/8.0	22.3/27.3	037	037	037	040
			CRHEATER326A00	10.5	7.9/9.6	26.9/32.9	040	040	040	040
			CRHEATER327A00	13.0	9.8/11.9	33.3/40.7	040	040	040	040
		HIGH	CRHEATER323A00	4.4	3.3/4.0	11.3/13.8	—	—	—	—
			CRHEATER324A00	6.5	4.9/6.0	16.7/20.4	—	—	—	037
			CRHEATER325A00	8.7	6.5/8.0	22.3/27.3	037	037	040	040
			CRHEATER326A00	10.5	7.9/9.6	26.9/32.9	040	040	040	040
			CRHEATER327A00	13.0	9.8/11.9	33.3/40.7	040	040	040	040

50FE-A04 1-Phase Electric Heat Data — With Non-Fused Disconnect

50FE UNIT SIZE	NOM. V-Ph-Hz	IFM TYPE	ELECTRIC HEATER PART NUMBER	NOM (kW)	APPLICATION (kW)	APPLICATION OUTPUT (MBH)	SINGLE POINT OR JUNCTION PART NUMBER CRSINGLEXXA00			
							No CO or Unpowered CO		With PWRD CO	
							No PE	With PE (pwrd fr/unit)	No PE	With PE (pwrd fr/unit)
-A04	208/230-1-60	MED	CRHEATER323A00	4.4	3.3/4.0	11.3/13.8	037	037	037	037
			CRHEATER324A00	6.5	4.9/6.0	16.7/20.4	037	037	037	037
			CRHEATER325A00	8.7	6.5/8.0	22.3/27.3	037	037	037	040
			CRHEATER326A00	10.5	7.9/9.6	26.9/32.9	040	040	040	040
			CRHEATER327A00	13.0	9.8/11.9	33.3/40.7	040	040	040	040
		HIGH	CRHEATER323A00	4.4	3.3/4.0	11.3/13.8	037	037	037	037
			CRHEATER324A00	6.5	4.9/6.0	16.7/20.4	037	037	037	037
			CRHEATER325A00	8.7	6.5/8.0	22.3/27.3	037	037	040	040
			CRHEATER326A00	10.5	7.9/9.6	26.9/32.9	040	040	040	040
			CRHEATER327A00	13.0	9.8/11.9	33.3/40.7	040	040	040	040

50FE-A04 3-Phase Electric Heat Data — Without Non-Fused Disconnect

50FE UNIT SIZE	NOM. V-Ph-Hz	IFM TYPE	ELECTRIC HEATER PART NUMBER	NOM (kW)	APPLICATION (kW)	APPLICATION OUTPUT (MBH)	SINGLE POINT OR JUNCTION PART NUMBER CRSINGLEXXXA00			
							No CO or Unpowered CO		With PWRD CO	
							No PE	With PE (pwrd fr/unit)	No PE	With PE (pwrd fr/unit)
-A04	208/230-3-60	MED	CRHEATER323A00	4.4	3.3/4.0	11.3/13.8	—	—	—	—
			CRHEATER324A00	6.5	4.9/6.0	16.7/20.4	—	—	—	—
			CRHEATER325A00	8.7	6.5/8.0	22.3/27.3	—	—	—	—
			CRHEATER326A00	10.5	7.9/9.6	26.9/32.9	—	—	—	—
		CRHEATER328A00	16.0	12.0/14.7	41.0/50.1	037	037	038	038	
		HIGH	CRHEATER323A00	4.4	3.3/4.0	11.3/13.8	—	—	—	—
			CRHEATER324A00	6.5	4.9/6.0	16.7/20.4	—	—	—	—
			CRHEATER325A00	8.7	6.5/8.0	22.3/27.3	—	—	—	—
	CRHEATER326A00		10.5	7.9/9.6	26.9/32.9	—	—	—	—	
	CRHEATER328A00	16.0	12.0/14.7	41.0/50.1	037	037	038	038		
	460-3-60	MED	CRHEATER333A00	6.0	5.5	18.8	—	—	—	—
			CRHEATER334A00	8.8	8.1	27.6	—	—	—	—
			CRHEATER335A00	11.5	10.6	36.0	—	—	—	—
			CRHEATER336A00	14.0	12.9	43.9	—	—	—	—
		HIGH	CRHEATER333A00	6.0	5.5	18.8	—	—	—	—
			CRHEATER334A00	8.8	8.1	27.6	—	—	—	—
			CRHEATER335A00	11.5	10.6	36.0	—	—	—	—
			CRHEATER336A00	14.0	12.9	43.9	—	—	—	—
	575-3-60	MED	CRHEATER339A00	10.0	9.2	31.3	—	—	—	—
			CRHEATER340A00	15.0	13.8	47.0	—	—	—	—
		HIGH	CRHEATER339A00	10.0	9.2	31.3	—	—	—	—
CRHEATER340A00			15.0	13.8	47.0	—	—	—	—	

50FE-A04 3-Phase Electric Heat Data — With Non-Fused Disconnect

50FE UNIT SIZE	NOM. V-Ph-Hz	IFM TYPE	ELECTRIC HEATER PART NUMBER	NOM (kW)	APPLICATION (kW)	APPLICATION OUTPUT (MBH)	SINGLE POINT OR JUNCTION PART NUMBER CRSINGLEXXXA00			
							No CO or Unpowered CO		With PWRD CO	
							No PE	With PE (pwrd fr/unit)	No PE	With PE (pwrd fr/unit)
-A04	208/230-3-60	MED	CRHEATER323A00	4.4	3.3/4.0	11.3/13.8	037	037	037	037
			CRHEATER324A00	6.5	4.9/6.0	16.7/20.4	037	037	037	037
			CRHEATER325A00	8.7	6.5/8.0	22.3/27.3	037	037	037	037
			CRHEATER326A00	10.5	7.9/9.6	26.9/32.9	037	037	037	037
		CRHEATER328A00	16.0	12.0/14.7	41.0/50.1	037	037	038	038	
		HIGH	CRHEATER323A00	4.4	3.3/4.0	11.3/13.8	037	037	037	037
			CRHEATER324A00	6.5	4.9/6.0	16.7/20.4	037	037	037	037
			CRHEATER325A00	8.7	6.5/8.0	22.3/27.3	037	037	037	037
	CRHEATER326A00		10.5	7.9/9.6	26.9/32.9	037	037	037	037	
	CRHEATER328A00	16.0	12.0/14.7	41.0/50.1	037	037	038	038		
	460-3-60	MED	CRHEATER333A00	6.0	5.5	18.8	—	—	—	—
			CRHEATER334A00	8.8	8.1	27.6	—	—	—	—
			CRHEATER335A00	11.5	10.6	36.0	—	—	—	—
			CRHEATER336A00	14.0	12.9	43.9	—	—	—	—
		HIGH	CRHEATER333A00	6.0	5.5	18.8	—	—	—	—
			CRHEATER334A00	8.8	8.1	27.6	—	—	—	—
			CRHEATER335A00	11.5	10.6	36.0	—	—	—	—
			CRHEATER336A00	14.0	12.9	43.9	—	—	—	—
	575-3-60	MED	CRHEATER339A00	10.0	9.2	31.3	—	—	—	—
			CRHEATER340A00	15.0	13.8	47.0	—	—	—	—
		HIGH	CRHEATER339A00	10.0	9.2	31.3	—	—	—	—
CRHEATER340A00			15.0	13.8	47.0	—	—	—	—	

50FE-A05 1-Phase Electric Heat Data — Without Non-Fused Disconnect

50FE UNIT SIZE	NOM. V-Ph-Hz	IFM TYPE	ELECTRIC HEATER PART NUMBER	NOM (kW)	APPLICATION (kW)	APPLICATION OUTPUT (MBH)	SINGLE POINT OR JUNCTION PART NUMBER CRSINGLEXXA00			
							No CO or Unpowered CO		With PWRD CO	
							No PE	With PE (pwrd fr/unit)	No PE	With PE (pwrd fr/unit)
-A05	208/230-1-60	MED	CRHEATER323A00	4.4	3.3/4.0	11.3/13.8	—	—	—	—
			CRHEATER325A00	8.7	6.5/8.0	22.3/27.3	037	037	040	040
			CRHEATER327A00	13.0	9.8/11.9	33.3/40.7	040	040	040	040
			CRHEATER329A00	17.4	13.1/16.0	44.6/54.5	040	040	040	040
			CRHEATER330A00	19.2	14.4/17.6	49.2/60.2	040	040	040	040
		CRHEATER331A00	21.0	15.8/19.3	53.8/65.8	040	040	040	040	
		HIGH	CRHEATER323A00	4.4	3.3/4.0	11.3/13.8	—	—	—	—
			CRHEATER325A00	8.7	6.5/8.0	22.3/27.3	037	037	040	040
			CRHEATER327A00	13.0	9.8/11.9	33.3/40.7	040	040	040	040
			CRHEATER329A00	17.4	13.1/16.0	44.6/54.5	040	040	040	040
CRHEATER330A00	19.2		14.4/17.6	49.2/60.2	040	040	040	040		
CRHEATER331A00	21.0	15.8/19.3	53.8/65.8	040	040	040	040			

50FE-A05 1-Phase Electric Heat Data — With Non-Fused Disconnect

50FE UNIT SIZE	NOM. V-Ph-Hz	IFM TYPE	ELECTRIC HEATER PART NUMBER	NOM (kW)	APPLICATION (kW)	APPLICATION OUTPUT (MBH)	SINGLE POINT OR JUNCTION PART NUMBER CRSINGLEXXA00			
							No CO or Unpowered CO		With PWRD CO	
							No PE	With PE (pwrd fr/unit)	No PE	With PE (pwrd fr/unit)
-A05	208/230-1-60	MED	CRHEATER323A00	4.4	3.3/4.0	11.3/13.8	037	037	037	037
			CRHEATER325A00	8.7	6.5/8.0	22.3/27.3	037	037	040	040
			CRHEATER327A00	13.0	9.8/11.9	33.3/40.7	040	040	040	040
			CRHEATER329A00	17.4	13.1/16.0	44.6/54.5	040	040	040	040
			CRHEATER330A00	19.2	14.4/17.6	49.2/60.2	040	040	040	040
		CRHEATER331A00	21.0	15.8/19.3	53.8/65.8	040	040	040	040	
		HIGH	CRHEATER323A00	4.4	3.3/4.0	11.3/13.8	037	037	037	037
			CRHEATER325A00	8.7	6.5/8.0	22.3/27.3	037	037	040	040
			CRHEATER327A00	13.0	9.8/11.9	33.3/40.7	040	040	040	040
			CRHEATER329A00	17.4	13.1/16.0	44.6/54.5	040	040	040	040
CRHEATER330A00	19.2		14.4/17.6	49.2/60.2	040	040	040	040		
CRHEATER331A00	21.0	15.8/19.3	53.8/65.8	040	040	040	040			

50FE-A05 3-Phase Electric Heat Data — Without Non-Fused Disconnect

50FE UNIT SIZE	NOM. V-Ph-Hz	IFM TYPE	ELECTRIC HEATER PART NUMBER	NOM (kW)	APPLICATION (kW)	APPLICATION OUTPUT (MBH)	SINGLE POINT OR JUNCTION PART NUMBER CRSINGLEXXXXA00			
							No CO or Unpowered CO		With PWRD CO	
							No PE	With PE (pwrd fr/unit)	No PE	With PE (pwrd fr/unit)
-05A	208/230-3-60	MED	CRHEATER323A00	4.4	3.3/4.0	11.3/13.8	—	—	—	—
			CRHEATER324A00	6.5	4.9/6.0	16.7/20.4	—	—	—	—
			CRHEATER325A00	8.7	6.5/8.0	22.3/27.3	—	—	—	—
			CRHEATER328A00	16.0	12.0/14.7	41.0/50.1	037	037	038	038
			CRHEATER330A00	19.2	14.4/17.6	49.2/60.2	038	038	038	038
			CRHEATER331A00	21.0	15.8/19.3	53.8/65.8	038	038	038	038
		HIGH	CRHEATER323A00	4.4	3.3/4.0	11.3/13.8	—	—	—	—
			CRHEATER324A00	6.5	4.9/6.0	16.7/20.4	—	—	—	—
			CRHEATER325A00	8.7	6.5/8.0	22.3/27.3	—	—	—	—
			CRHEATER328A00	16.0	12.0/14.7	41.0/50.1	037	037	038	038
			CRHEATER330A00	19.2	14.4/17.6	49.2/60.2	038	038	038	038
			CRHEATER331A00	21.0	15.8/19.3	53.8/65.8	038	038	038	038
	460-3-60	MED	CRHEATER333A00	6.0	5.5	18.8	—	—	—	—
			CRHEATER335A00	11.5	10.6	36.0	—	—	—	—
			CRHEATER336A00	14.0	12.9	43.9	—	—	—	—
			CRHEATER337A00	21.5	19.7	67.4	037	037	037	037
		HIGH	CRHEATER333A00	6.0	5.5	18.8	—	—	—	—
			CRHEATER335A00	11.5	10.6	36.0	—	—	—	—
			CRHEATER337A00	21.5	19.7	67.4	037	037	037	037
	575-3-60	MED	CRHEATER339A00	10.0	9.2	31.3	—	—	—	—
			CRHEATER340A00	15.0	13.8	47.0	—	—	—	—
HIGH		CRHEATER339A00	10.0	9.2	31.3	—	—	—	—	
		CRHEATER340A00	15.0	13.8	47.0	—	—	—	—	

50FE-A05 3-Phase Electric Heat Data — With Non-Fused Disconnect

50FE UNIT SIZE	NOM. V-Ph-Hz	IFM TYPE	ELECTRIC HEATER PART NUMBER	NOM (kW)	APPLICATION (kW)	APPLICATION OUTPUT (MBH)	SINGLE POINT OR JUNCTION PART NUMBER CRSINGLEXXXXA00			
							No CO or Unpowered CO		With PWRD CO	
							No PE	With PE (pwrd fr/unit)	No PE	With PE (pwrd fr/unit)
-A05	208/230-3-60	MED	CRHEATER323A00	4.4	3.3/4.0	11.3/13.8	037	037	037	037
			CRHEATER324A00	6.5	4.9/6.0	16.7/20.4	037	037	037	037
			CRHEATER325A00	8.7	6.5/8.0	22.3/27.3	037	037	037	037
			CRHEATER328A00	16.0	12.0/14.7	41.0/50.1	037	037	038	038
			CRHEATER330A00	19.2	14.4/17.6	49.2/60.2	038	038	038	038
			CRHEATER331A00	21.0	15.8/19.3	53.8/65.8	038	038	038	038
		HIGH	CRHEATER323A00	4.4	3.3/4.0	11.3/13.8	037	037	037	037
			CRHEATER324A00	6.5	4.9/6.0	16.7/20.4	037	037	037	037
			CRHEATER325A00	8.7	6.5/8.0	22.3/27.3	037	037	037	037
			CRHEATER328A00	16.0	12.0/14.7	41.0/50.1	037	037	038	038
			CRHEATER330A00	19.2	14.4/17.6	49.2/60.2	038	038	038	038
			CRHEATER331A00	21.0	15.8/19.3	53.8/65.8	038	038	038	038
	460-3-60	MED	CRHEATER333A00	6.0	5.5	18.8	—	—	—	—
			CRHEATER335A00	11.5	10.6	36.0	—	—	—	—
			CRHEATER336A00	14.0	12.9	43.9	—	—	—	—
			CRHEATER337A00	21.5	19.7	67.4	037	037	037	037
		HIGH	CRHEATER333A00	6.0	5.5	18.8	—	—	—	—
			CRHEATER335A00	11.5	10.6	36.0	—	—	—	—
			CRHEATER337A00	21.5	19.7	67.4	037	037	037	037
	575-3-60	MED	CRHEATER339A00	10.0	9.2	31.3	—	—	—	—
			CRHEATER340A00	15.0	13.8	47.0	—	—	—	—
HIGH		CRHEATER339A00	10.0	9.2	31.3	—	—	—	—	
		CRHEATER340A00	15.0	13.8	47.0	—	—	—	—	

50FE-A06 1-Phase Electric Heat Data — Without Non-Fused Disconnect

50FE UNIT SIZE	NOM. V-Ph-Hz	IFM TYPE	ELECTRIC HEATER PART NUMBER	NOM (kW)	APPLICATION (kW)	APPLICATION OUTPUT (MBH)	SINGLE POINT OR JUNCTION PART NUMBER CRSINGLEXXXA00			
							No CO or Unpowered CO		With PWRD CO	
							No PE	With PE (pwrd fr/unit)	No PE	With PE (pwrd fr/unit)
-A06	208/230-1-60	MED	CRHEATER324A00	6.5	4.9/6.0	16.7/20.4	—	—	037	037
			CRHEATER325A00	8.7	6.5/8.0	22.3/27.3	037	037	040	040
			CRHEATER327A00	13.0	9.8/11.9	33.3/40.7	040	040	040	040
			CRHEATER329A00	17.4	13.1/16.0	44.6/54.5	040	040	040	040
			CRHEATER331A00	21.0	15.8/19.3	53.8/65.8	040	040	040	040
		HIGH	CRHEATER324A00	6.5	4.9/6.0	16.7/20.4	—	037	037	037
			CRHEATER325A00	8.7	6.5/8.0	22.3/27.3	037	040	040	040
			CRHEATER327A00	13.0	9.8/11.9	33.3/40.7	040	040	040	040
			CRHEATER329A00	17.4	13.1/16.0	44.6/54.5	040	040	040	040
			CRHEATER331A00	21.0	15.8/19.3	53.8/65.8	040	040	040	040

50FE-A06 1-Phase Electric Heat Data — With Non-Fused Disconnect

50FE UNIT SIZE	NOM. V-Ph-Hz	IFM TYPE	ELECTRIC HEATER PART NUMBER	NOM (kW)	APPLICATION (kW)	APPLICATION OUTPUT (MBH)	SINGLE POINT OR JUNCTION PART NUMBER CRSINGLEXXXA00			
							No CO or Unpowered CO		With PWRD CO	
							No PE	With PE (pwrd fr/unit)	No PE	With PE (pwrd fr/unit)
-A06	208/230-1-60	MED	CRHEATER324A00	6.5	4.9/6.0	16.7/20.4	037	037	037	037
			CRHEATER325A00	8.7	6.5/8.0	22.3/27.3	037	037	040	040
			CRHEATER327A00	13.0	9.8/11.9	33.3/40.7	040	040	040	040
			CRHEATER329A00	17.4	13.1/16.0	44.6/54.5	040	040	040	040
			CRHEATER331A00	21.0	15.8/19.3	53.8/65.8	040	040	040	040
		HIGH	CRHEATER324A00	6.5	4.9/6.0	16.7/20.4	037	037	037	037
			CRHEATER325A00	8.7	6.5/8.0	22.3/27.3	037	040	040	040
			CRHEATER327A00	13.0	9.8/11.9	33.3/40.7	040	040	040	040
			CRHEATER329A00	17.4	13.1/16.0	44.6/54.5	040	040	040	040
			CRHEATER331A00	21.0	15.8/19.3	53.8/65.8	040	040	040	040

50FE-A06 3-Phase Electric Heat Data — Without Non-Fused Disconnect

50FE UNIT SIZE	NOM. V-Ph-Hz	IFM TYPE	ELECTRIC HEATER PART NUMBER	NOM (kW)	APPLICATION (kW)	APPLICATION OUTPUT (MBH)	SINGLE POINT OR JUNCTION PART NUMBER CRSINGLEXXXA00			
							No CO or Unpowered CO		With PWRD CO	
							No PE	With PE (pwrd fr/unit)	No PE	With PE (pwrd fr/unit)
-A06	208/230-3-60	MED	CRHEATER324A00	6.5	4.9/6.0	16.7/20.4	—	—	—	—
			CRHEATER326A00	10.5	7.9/9.6	26.9/32.9	—	—	—	037
			CRHEATER328A00	16.0	12.0/14.7	41.0/50.1	037	038	038	038
			CRHEATER331A00	21.0	15.8/19.3	53.8/65.8	038	038	038	038
			CRHEATER332A00	24.5	18.4/22.5	62.8/76.8	038	038	038	038
			CRHEATER332A00	24.5	18.4/22.5	62.8/76.8	038	038	038	038
		HIGH	CRHEATER324A00	6.5	4.9/6.0	16.7/20.4	—	—	—	—
			CRHEATER326A00	10.5	7.9/9.6	26.9/32.9	—	—	—	—
			CRHEATER328A00	16.0	12.0/14.7	41.0/50.1	037	037	038	038
			CRHEATER331A00	21.0	15.8/19.3	53.8/65.8	038	038	038	038
			CRHEATER332A00	24.5	18.4/22.5	62.8/76.8	038	038	038	038
			CRHEATER332A00	24.5	18.4/22.5	62.8/76.8	038	038	038	038
	460-3-60	MED	CRHEATER333A00	6.0	5.5	18.8	—	—	—	—
			CRHEATER335A00	11.5	10.6	36.0	—	—	—	—
			CRHEATER336A00	14.0	12.9	43.9	—	—	—	—
			CRHEATER337A00	21.5	19.7	67.4	037	037	037	037
			CRHEATER338A00	24.0	22.0	75.2	037	037	037	037
			CRHEATER338A00	24.0	22.0	75.2	037	037	037	037
		HIGH	CRHEATER333A00	6.0	5.5	18.8	—	—	—	—
			CRHEATER335A00	11.5	10.6	36.0	—	—	—	—
			CRHEATER336A00	14.0	12.9	43.9	—	—	—	—
			CRHEATER337A00	21.5	19.7	67.4	037	037	037	037
			CRHEATER338A00	24.0	22.0	75.2	037	037	037	037
			CRHEATER338A00	24.0	22.0	75.2	037	037	037	037
575-3-60	MED	CRHEATER340A00	15.0	13.8	47.0	—	—	—	—	
		CRHEATER341A00	21.0	19.3	65.8	037	037	037	037	
	HIGH	CRHEATER340A00	15.0	13.8	47.0	—	—	—	—	
		CRHEATER341A00	21.0	19.3	65.8	037	037	037	037	

50FE-A06 3-Phase Electric Heat Data — With Non-Fused Disconnect

50FE UNIT SIZE	NOM. V-Ph-Hz	IFM TYPE	ELECTRIC HEATER PART NUMBER	NOM (kW)	APPLICATION (kW)	APPLICATION OUTPUT (MBH)	SINGLE POINT OR JUNCTION PART NUMBER CRSINGLEXXXA00			
							No CO or Unpowered CO		With PWRD CO	
							No PE	With PE (pwrd fr/unit)	No PE	With PE (pwrd fr/unit)
-A06	208/230-3-60	MED	CRHEATER324A00	6.5	4.9/6.0	16.7/20.4	037	037	037	037
			CRHEATER326A00	10.5	7.9/9.6	26.9/32.9	037	037	037	037
			CRHEATER328A00	16.0	12.0/14.7	41.0/50.1	037	038	038	038
			CRHEATER331A00	21.0	15.8/19.3	53.8/65.8	038	038	038	038
			CRHEATER332A00	24.5	18.4/22.5	62.8/76.8	038	038	038	038
			CRHEATER332A00	24.5	18.4/22.5	62.8/76.8	038	038	038	038
		HIGH	CRHEATER324A00	6.5	4.9/6.0	16.7/20.4	037	037	037	037
			CRHEATER326A00	10.5	7.9/9.6	26.9/32.9	037	037	037	037
			CRHEATER328A00	16.0	12.0/14.7	41.0/50.1	037	037	038	038
			CRHEATER331A00	21.0	15.8/19.3	53.8/65.8	038	038	038	038
			CRHEATER332A00	24.5	18.4/22.5	62.8/76.8	038	038	038	038
			CRHEATER332A00	24.5	18.4/22.5	62.8/76.8	038	038	038	038
	460-3-60	MED	CRHEATER333A00	6.0	5.5	18.8	—	—	—	—
			CRHEATER335A00	11.5	10.6	36.0	—	—	—	—
			CRHEATER336A00	14.0	12.9	43.9	—	—	—	—
			CRHEATER337A00	21.5	19.7	67.4	037	037	037	037
			CRHEATER338A00	24.0	22.0	75.2	037	037	037	037
			CRHEATER338A00	24.0	22.0	75.2	037	037	037	037
		HIGH	CRHEATER333A00	6.0	5.5	18.8	—	—	—	—
			CRHEATER335A00	11.5	10.6	36.0	—	—	—	—
			CRHEATER336A00	14.0	12.9	43.9	—	—	—	—
			CRHEATER337A00	21.5	19.7	67.4	037	037	037	037
			CRHEATER338A00	24.0	22.0	75.2	037	037	037	037
			CRHEATER338A00	24.0	22.0	75.2	037	037	037	037
575-3-60	MED	CRHEATER340A00	15.0	13.8	47.0	—	—	—	—	
		CRHEATER341A00	21.0	19.3	65.8	037	037	037	037	
	HIGH	CRHEATER340A00	15.0	13.8	47.0	—	—	—	—	
		CRHEATER341A00	21.0	19.3	65.8	037	037	037	037	

50FE-*07 Electric Heat Data — Without Non-Fused Disconnect

50FE UNIT SIZE	NOM. V-Ph-Hz	IFM TYPE	ELECTRIC HEATER PART NUMBER	NOM (kW)	APPLICATION (kW)	APPLICATION OUTPUT (MBH)	SINGLE POINT OR JUNCTION PART NUMBER CRSINGLEXXXA00				
							No CO or Unpowered CO		With PWRD CO		
							No PE	With PE (pwrd fr/unit)	No PE	With PE (pwrd fr/unit)	
*07	208/230-3-60	MED	CRHEATER324A00	6.5	4.9/6.0	16.7/20.4	—	—	—	—	
			CRHEATER326A00	10.5	7.9/9.6	26.9/32.9	—	—	—	—	
			CRHEATER328A00	16.0	12.0/14.7	41.0/50.1	037	037	038	038	
			CRHEATER331A00	21.0	15.8/19.3	53.8/65.8	038	038	038	038	
			CRHEATER332A00	24.5	18.4/22.5	62.8/76.8	038	038	038	038	
		HIGH	CRHEATER324A00	6.5	4.9/6.0	16.7/20.4	—	—	—	—	
			CRHEATER326A00	10.5	7.9/9.6	26.9/32.9	—	—	—	—	
			CRHEATER328A00	16.0	12.0/14.7	41.0/50.1	037	037	038	038	
			CRHEATER331A00	21.0	15.8/19.3	53.8/65.8	038	038	038	038	
			CRHEATER332A00	24.5	18.4/22.5	62.8/76.8	038	038	038	038	
		460-3-60	MED	CRHEATER333A00	6.0	5.5	18.8	—	—	—	—
				CRHEATER335A00	11.5	10.6	36.0	—	—	—	—
	CRHEATER336A00			14.0	12.9	43.9	—	—	—	—	
	CRHEATER337A00			21.5	19.7	67.4	037	037	037	037	
	CRHEATER338A00			24.0	22.0	75.2	037	037	037	037	
	HIGH		CRHEATER333A00	6.0	5.5	18.8	—	—	—	—	
			CRHEATER335A00	11.5	10.6	36.0	—	—	—	—	
			CRHEATER336A00	14.0	12.9	43.9	—	—	—	—	
			CRHEATER337A00	21.5	19.7	67.4	037	037	037	037	
			CRHEATER338A00	24.0	22.0	75.2	037	037	037	037	
	575-3-60		MED	CRHEATER340A00	15.0	13.8	47.0	—	—	—	—
				CRHEATER341A00	21.0	19.3	65.8	037	037	037	037
		HIGH	CRHEATER340A00	15.0	13.8	47.0	—	—	—	—	
			CRHEATER341A00	21.0	19.3	65.8	037	037	037	037	

50FE-*07 Electric Heat Data — With Non-Fused Disconnect

50FE UNIT SIZE	NOM. V-Ph-Hz	IFM TYPE	ELECTRIC HEATER PART NUMBER	NOM (kW)	APPLICATION (kW)	APPLICATION OUTPUT (MBH)	SINGLE POINT OR JUNCTION PART NUMBER CRSINGLEXXXA00				
							No CO or Unpowered CO		With PWRD CO		
							No PE	With PE (pwrd fr/unit)	No PE	With PE (pwrd fr/unit)	
*07	208/230-3-60	MED	CRHEATER324A00	6.5	4.9/6.0	16.7/20.4	037	037	037	037	
			CRHEATER326A00	10.5	7.9/9.6	26.9/32.9	037	037	037	037	
			CRHEATER328A00	16.0	12.0/14.7	41.0/50.1	037	037	038	038	
			CRHEATER331A00	21.0	15.8/19.3	53.8/65.8	038	038	038	038	
			CRHEATER332A00	24.5	18.4/22.5	62.8/76.8	038	038	038	038	
		HIGH	CRHEATER324A00	6.5	4.9/6.0	16.7/20.4	037	037	037	037	
			CRHEATER326A00	10.5	7.9/9.6	26.9/32.9	037	037	037	037	
			CRHEATER328A00	16.0	12.0/14.7	41.0/50.1	037	037	038	038	
			CRHEATER331A00	21.0	15.8/19.3	53.8/65.8	038	038	038	038	
			CRHEATER332A00	24.5	18.4/22.5	62.8/76.8	038	038	038	038	
		460-3-60	MED	CRHEATER333A00	6.0	5.5	18.8	—	—	—	—
				CRHEATER335A00	11.5	10.6	36.0	—	—	—	—
	CRHEATER336A00			14.0	12.9	43.9	—	—	—	—	
	CRHEATER337A00			21.5	19.7	67.4	037	037	037	037	
	CRHEATER338A00			24.0	22.0	75.2	037	037	037	037	
	HIGH		CRHEATER333A00	6.0	5.5	18.8	—	—	—	—	
			CRHEATER335A00	11.5	10.6	36.0	—	—	—	—	
			CRHEATER336A00	14.0	12.9	43.9	—	—	—	—	
			CRHEATER337A00	21.5	19.7	67.4	037	037	037	037	
			CRHEATER338A00	24.0	22.0	75.2	037	037	037	037	
	575-3-60		MED	CRHEATER340A00	15.0	13.8	47.0	—	—	—	—
				CRHEATER341A00	21.0	19.3	65.8	037	037	037	037
		HIGH	CRHEATER340A00	15.0	13.8	47.0	—	—	—	—	
			CRHEATER341A00	21.0	19.3	65.8	037	037	037	037	

Typical Control Wiring Diagram — SystemVu™ Controller — 48FE 04-06 Units Shown

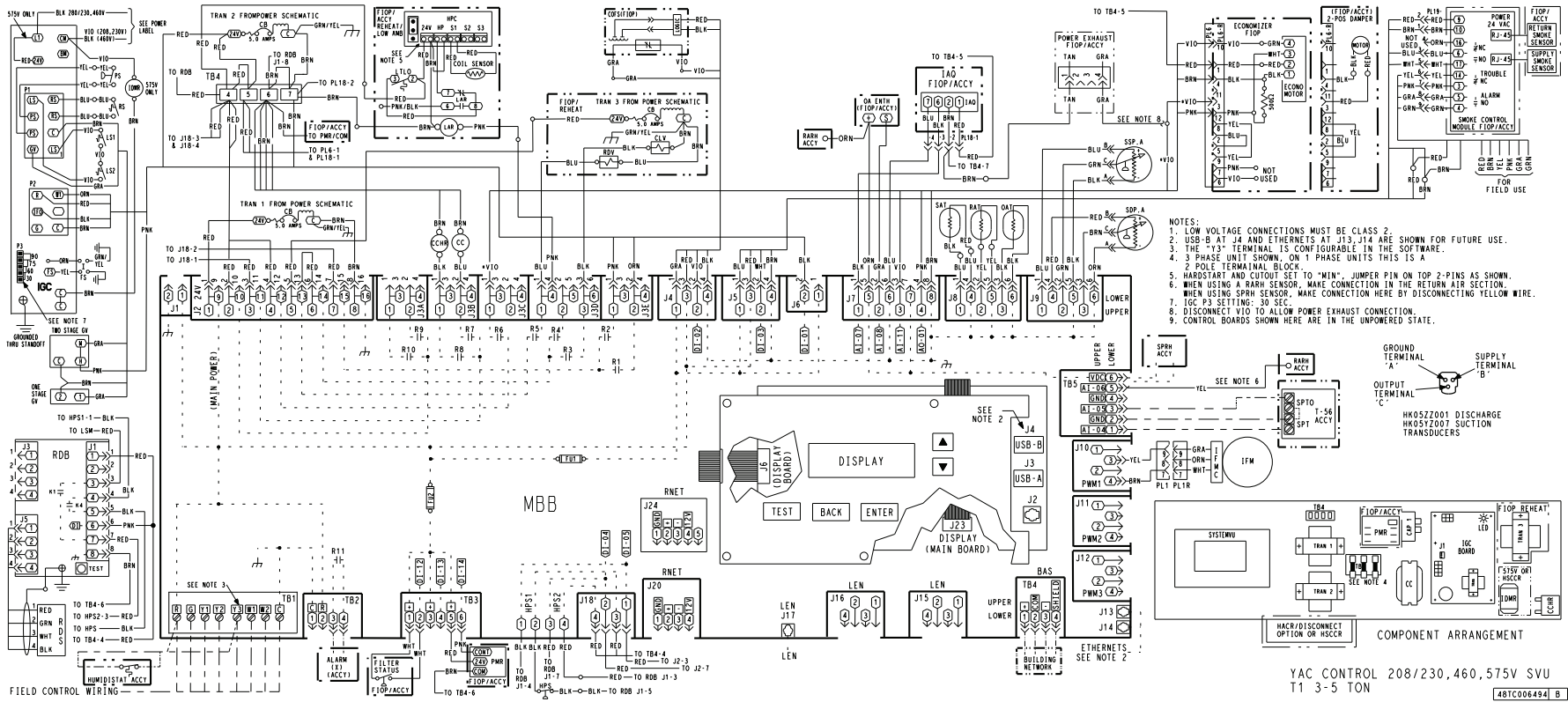

Typical Control Wiring Diagram — SystemVu™ Controller — 48FE 04-06 Ultra Low NOx Units Shown

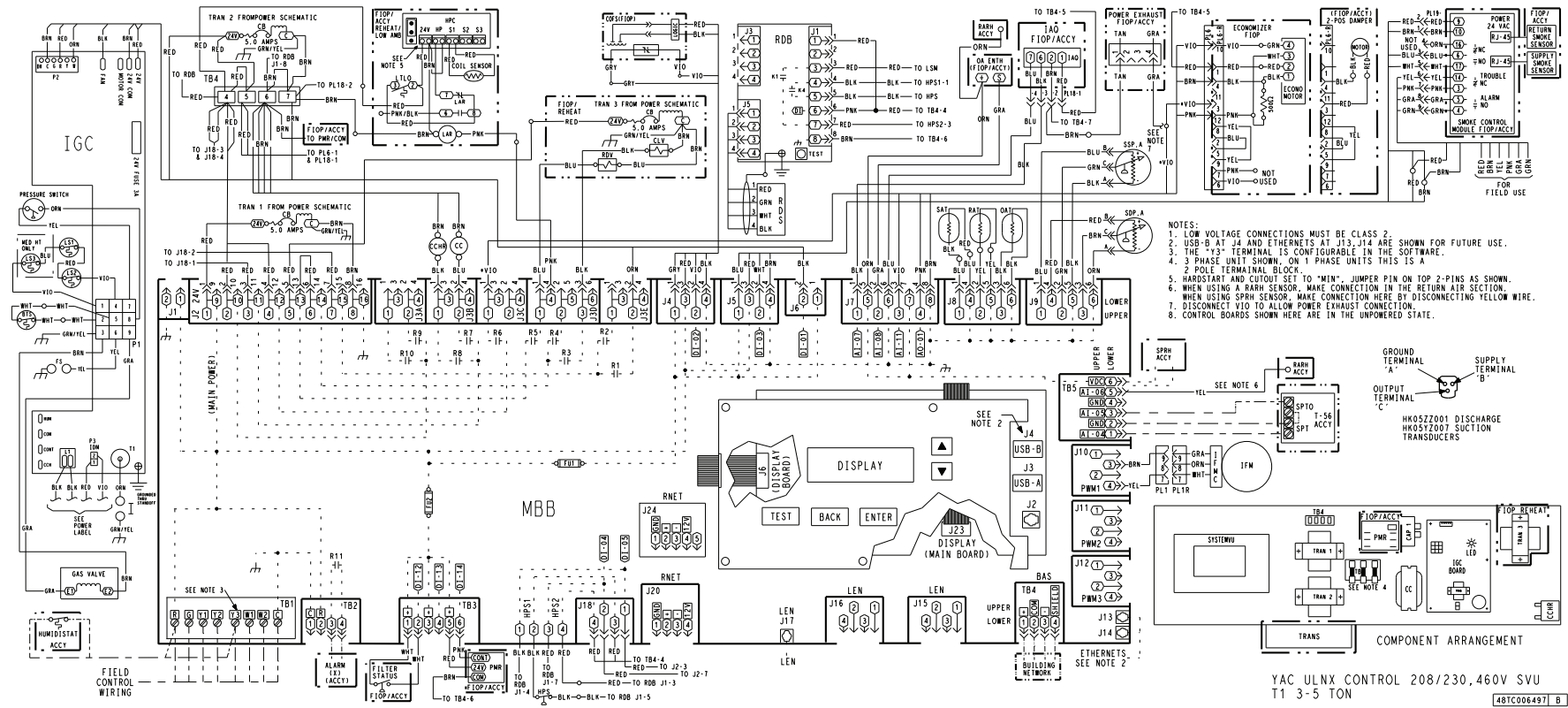

Typical Control Wiring Diagram — SystemVu™ Controller — 48FE 07 Units Shown

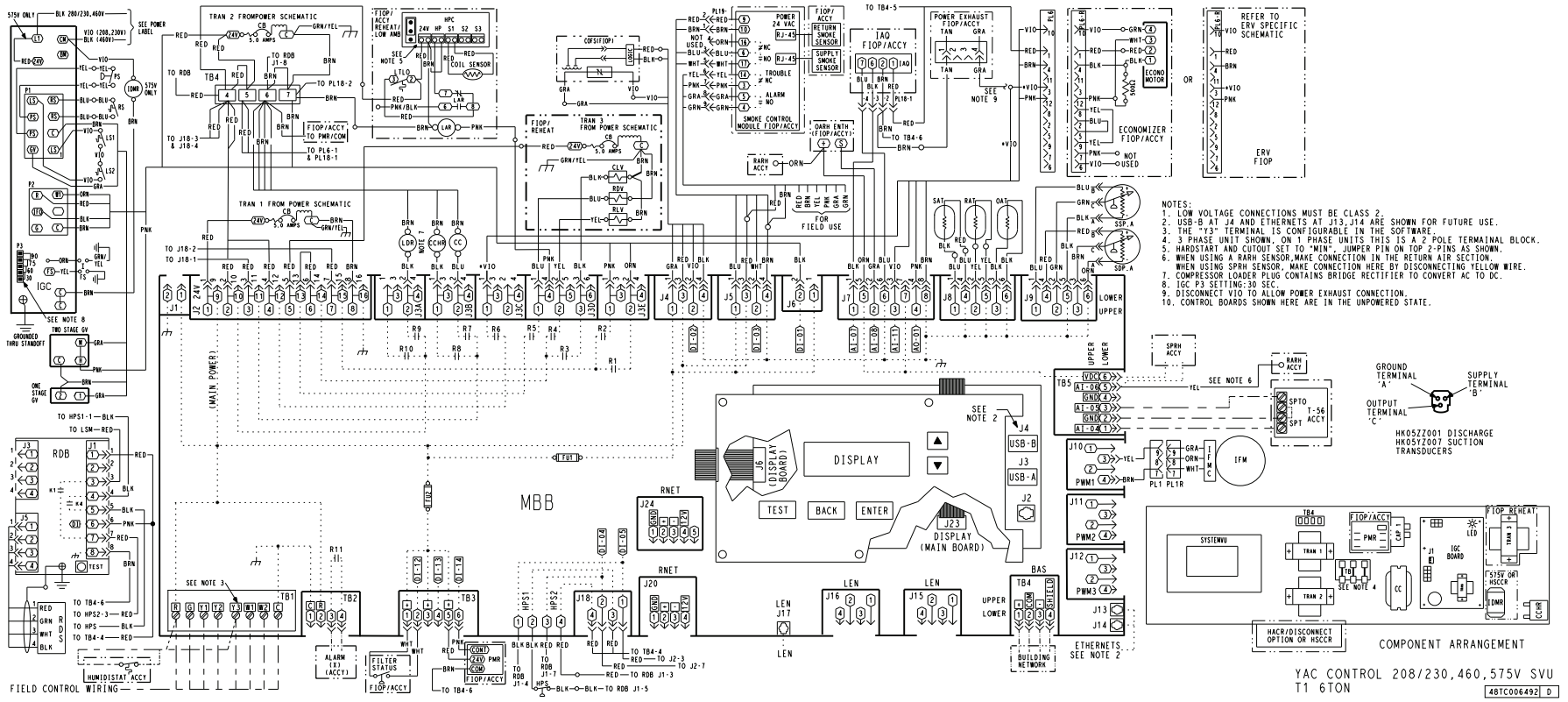

Typical Power Wiring Diagram for Electromechanical Units, 48FE 04-07, 460/575-3-60 Units Shown

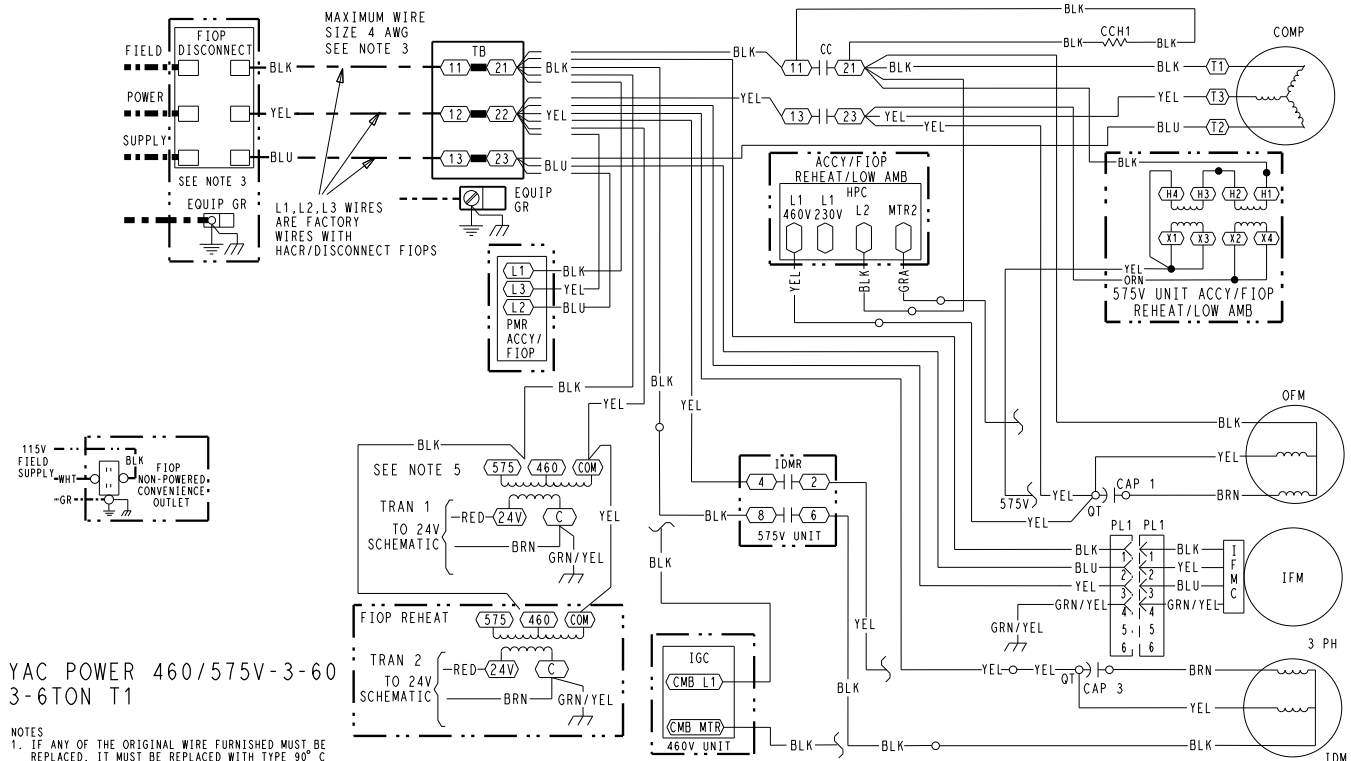

YAC POWER 460/575V-3-60
3-6TON T1

- NOTES**
- IF ANY OF THE ORIGINAL WIRE FURNISHED MUST BE REPLACED, IT MUST BE REPLACED WITH TYPE 90° C WIRE OR ITS EQUIVALENT.
 - COMPRESSOR AND FAN MOTORS ARE THERMALLY PROTECTED.
 - USE COPPER CONDUCTOR ONLY.
 - DO NOT DISCONNECT POWER PLUG OR SIGNAL WIRE WHILE UNDER LOAD.
 - TRANSFORMER IS DEDICATED BASED ON UNIT VOLTAGE. TAPS ONLY SHOWN TO SIMPLIFY SCHEMATIC.

LEGEND

- MARKED WIRE
- TERMINAL (MARKED)
- TERMINAL (UNMARKED)
- TERMINAL BLOCK
- SPLICE
- SPLICE (MARKED)
- FACTORY WIRING
- FIELD CONTROL WIRING
- FIELD POWER WIRING
- CIRCUIT BOARD TRACE
- ACCESSORY OR OPTIONAL WIRING

ACCY	ACCESSORY	HACR	HEATING, AIR-CONDITIONING, REFRIGERATION BREAKER	OL	OVERLOAD
AUX	AUXILIARY	HGRH	HOT GAS REHEAT	PER	POWER EXHAUST RELAY
AWG	AMERICAN WIRE GAGE	HPC	HEAD PRESSURE CONTROL	PH	PHASE
BA	BUILDING AUTOMATION NETWORK	HPS	HIGH PRESSURE SWITCH	PL	PLUG ASSEMBLY
CC	CONTACTOR, COMPRESSOR	HR	HEATER RELAY	POT	POTENTIOMETER
C	COMMON	HUM	HUMIDISTAT	PMR	PHASE MONITOR RELAY
CAP	CAPACITOR	IAQ	INDOOR AIR QUALITY SENSORS	PS	PRESSURE SWITCH
CIRCB	CIRCUIT BREAKER	IDM	INDUCED DRAFT MOTOR	PWM	PULSE WIDTH MODULATION
CCH	CRANKCASE HEATER	IDMR	INDUCED DRAFT RELAY	QT	QUADRUPLE TERMINAL
CCHR	CRANKCASE HEATER RELAY	IFM	INDOOR FAN MOTOR	R	THERMOSTAT POWER
CCHTS	CRANKCASE HEATER TEMP SWITCH	IFMC	INDOOR FAN MOTOR CONTROL	RAT	RETURN AIR TEMP. SEN
CLO	COMPRESSOR LOCKOUT	IFO	INDOOR FAN ON SIGNAL	RDB	REFRIGERANT DISSIPATION BOARD
CLV	COOLING LIQUID VALVE	IRH	INDOOR RELATIVE HUMIDITY	RDS	REFRIGERANT DISSIPATION SENSOR
CMB	CENTRIFUGAL MOTOR BLOWER	JMP	JUMPER	RDV	REHEAT DISCHARGE VALVE
COFS	CONDENSATE OVERFLOW SWITCH	LA	LINE 1	RH	RELATIVE HUMIDITY
COM	SIGNAL COMMON	LAR	LOW AMBIENT RELAY	RLV	REHEAT LIQUID VALVE
COMP	COMPRESSOR MOTOR	LAS	LOW AMBIENT SWITCH	RNET	LOCAL ACCESS NETWORK
DDC	DIRECT DIGITAL CONTROL	LDR	COMPRESSOR LOADER	RS	ROLLOUT SWITCH
DFB	DEFROST BOARD	LEN	LOCAL EQUIPMENT NETWORK	RVS	REVERSING VALVE SOLENOID
DFT	DEFROST THERMOSTAT	LOC	LOSS OF CHARGE	SAT	SUPPLY AIR TEMP. SENSOR
EHR	ELECTRIC HEAT RELAY	LOOP PWR	CURRENT LOOP POWER	SDP	SYSTEM DISCHARGE PRESSURE
ENTH	ENTHALPY	LPS	LOW PRESSURE SWITCH	SPRH	SPACE RELATIVE HUMIDITY
EQUIP	EQUIPMENT	LS	LIMIT SWITCH	SPT	SPACE TEMPERATURE SENSOR
ERV	ENERGY RECOVERY VENTILATOR	LSM	LIMIT SWITCH (MANUAL RESET)	SPTO	SPACE TEMPERATURE OFFSET
ESL	ENTHALPY SENSOR - LOW	LTL	LOW TEMP LOCKOUT	SSP	SYSTEM SUCTION PRESSURE
FB	FUSE BLOCK	MBB	MAIN BASE BOARD	STD	STANDARD
FIOF	FACTORY INSTALLED OPTION	MOV	METAL OXIDE VARISTOR	SW	SWITCH
FPT	FREEZE PROTECTION THERMOSTAT	MTR	MOTOR	TB	TERMINAL BLOCK
FS	FLAME SWITCH	OAO	OUTDOOR AIR QUALITY	TDR	TIME DELAY RELAY
FST	FAN HOUSING TEMP SENSOR	OAT	OUTDOOR AIR TEMP., SEN	TRAN	TRANSFORMER
FU	FUSE	OFM	OUTDOOR FAN MOTOR	UCB	UNIT CONTROL BOARD
G	THERMOSTAT FAN CALL	OFR	OUTDOOR FAN RELAY	W1	1st STAGE OF HEATING CALL
GR(GND)	GROUND			W2	2nd STAGE OF HEATING CALL
GV	GAS VALVE			Y1	1st STAGE OF COOLING CALL
				Y2	2nd STAGE OF COOLING CALL

48TC00292 H

Typical wiring diagrams (cont)



Typical Power Wiring Diagram for Electromechanical Units, 48FE 04-06 Ultra Low NOx Units, 460-3-60 Unit Shown

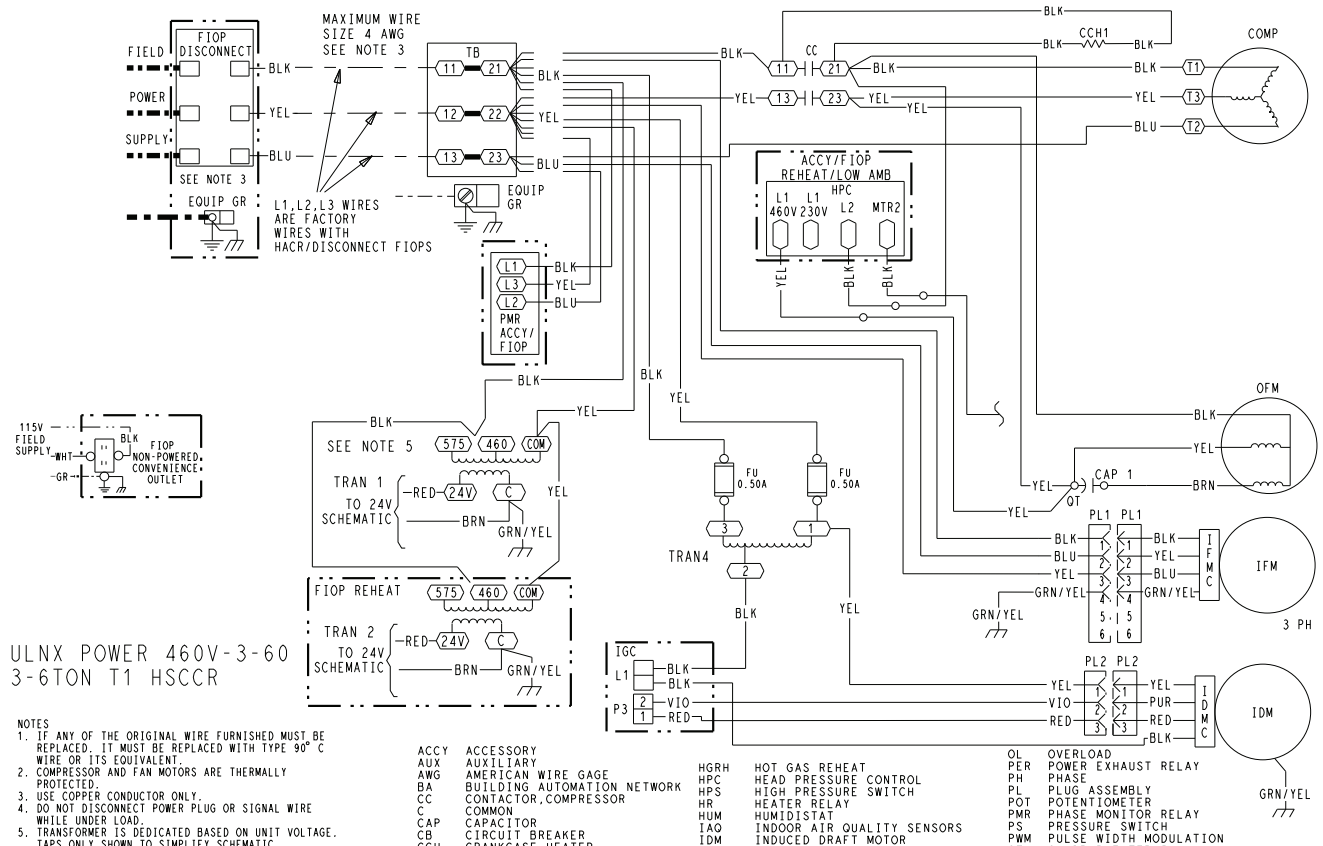

ULNX POWER 460V-3-60
3-6TON T1 HSCCR

- NOTES**
- IF ANY OF THE ORIGINAL WIRE FURNISHED MUST BE REPLACED, IT MUST BE REPLACED WITH TYPE 90° C WIRE OR ITS EQUIVALENT.
 - COMPRESSOR AND FAN MOTORS ARE THERMALLY PROTECTED.
 - USE COPPER CONDUCTOR ONLY.
 - DO NOT DISCONNECT POWER PLUG OR SIGNAL WIRE WHILE UNDER LOAD.
 - TRANSFORMER IS DEDICATED BASED ON UNIT VOLTAGE. TAPS ONLY SHOWN TO SIMPLIFY SCHEMATIC.

- LEGEND**
- (X) MARKED WIRE
 - (X) TERMINAL (MARKED)
 - () TERMINAL (UNMARKED)
 - (X) TERMINAL BLOCK
 - SPLICE
 - SPLICE (MARKED)
 - FACTORY WIRING
 - - - FIELD CONTROL WIRING
 - FIELD POWER WIRING
 - CIRCUIT BOARD TRACE
 - ACCESSORY OR OPTIONAL WIRING

- | | | | | | |
|---------|--------------------------------------------------|-------|--------------------------------|------|--------------------------------|
| ACCY | ACCESSORY | HGRH | HOT GAS REHEAT | OL | OVERLOAD |
| AUX | AUXILIARY | HPC | HEAD PRESSURE CONTROL | PER | POWER EXHAUST RELAY |
| AWG | AMERICAN WIRE GAGE | HPS | HIGH PRESSURE SWITCH | PH | PHASE |
| BA | BUILDING AUTOMATION NETWORK | HR | HEATER RELAY | PL | PLUG ASSEMBLY |
| CC | CONTACTOR, COMPRESSOR | HUM | HUMIDISTAT | POT | POTENTIOMETER |
| C | COMMON | IADQ | INDOOR AIR QUALITY SENSORS | PMR | PHASE MONITOR RELAY |
| CAP | CAPACITOR | IDM | INDUCED DRAFT MOTOR | PS | PRESSURE SWITCH |
| CB | CIRCUIT BREAKER | IDMC | INDUCED DRAFT MOTOR CONTROLLER | PWM | PULSE WIDTH MODULATION |
| CCH | CRANKCASE HEATER | IDMR | INDUCED DRAFT RELAY | QT | QUADRUPLE TERMINAL |
| CCHR | CRANKCASE HEATER RELAY | IDMTR | INDOOR FAN MOTOR | R | THERMOSTAT POWER |
| CCHTS | CRANKCASE HEATER TEMP SWITCH | IFM | INDOOR FAN MOTOR CONTROL | RAT | RETURN AIR TEMP. SEN |
| CLO | COMPRESSOR LOCKOUT | IFMC | INDOOR FAN ON SIGNAL | RDB | REFRIGERANT DISSIPATION BOARD |
| CLV | COOLING LIQUID VALVE | IFO | INDOOR FAN ON SIGNAL | RDS | REFRIGERANT DISSIPATION SENSOR |
| CMB | CENTRIFUGAL MOTOR BLOWER | IGC | INTEGRATED GAS CONTROL | RDV | REHEAT DISCHARGE VALVE |
| COFS | CONDENSATE OVERFLOW SWITCH | IGN | IGNITOR | RH | RELATIVE HUMIDITY |
| COM | SIGNAL COMMON | IRH | INDOOR RELATIVE HUMIDITY | RLV | REHEAT LIQUID VALVE |
| COMP | COMPRESSOR MOTOR | J | JUMPER | RNET | LOCAL ACCESS NETWORK |
| DDC | DIRECT DIGITAL CONTROL | JMP | JUMPER | RS | ROLLOUT SWITCH |
| DFB | DEFROST BOARD | L1 | LINE 1 | RVS | REVERSING VALVE SOLENOID |
| DFT | DEFROST THERMOSTAT | LA | LOW AMBIENT LOCKOUT | SAT | SUPPLY AIR TEMP SENSOR |
| EHR | ELECTRIC HEAT RELAY | LAR | LOW AMBIENT RELAY | SDP | SYSTEM DISCHARGE PRESSURE |
| ENTH | ENTHALPY | LAS | LOW AMBIENT SWITCH | SPRH | SPACE RELATIVE HUMIDITY |
| EQUIP | EQUIPMENT | LDR | COMPRESSOR LOADER | SPT | SPACE TEMPERATURE SENSOR |
| ERV | ENERGY RECOVERY VENTILATOR | LEN | LOCAL EQUIPMENT NETWORK | SPTO | SPACE TEMPERATURE OFFSET |
| ESL | ENTHALPY SENSOR - LOW | LOP | LOSS OF CHARGE | SSP | SYSTEM SUCTION PRESSURE |
| FB | FUSE BLOCK | LPS | LOW PRESSURE SWITCH | STD | STANDARD |
| FIOP | FACTORY INSTALLED OPTION | LS | LIMIT SWITCH | SW | SWITCH |
| FPT | FREEZE PROTECTION THERMOSTAT | LSM | LIMIT SWITCH (MANUAL RESET) | TB | TERMINAL BLOCK |
| FS | FLAME SWITCH | LTO | LOW TEMP LOCKOUT | TDR | TIME DELAY RELAY |
| FSST | FAN HOUSING TEMP SENSOR | MBB | MAIN BASE BOARD | TRAN | TRANSFORMER |
| FU | FUSE | MOV | METAL OXIDE VARISTOR | UCB | UNIT CONTROL BOARD |
| G | THERMOSTAT FAN CALL | MTR | MOTOR | W1 | 1st STAGE OF HEATING CALL |
| GR(GND) | GROUND | OAO | OUTDOOR AIR QUALITY | W2 | 2nd STAGE OF HEATING CALL |
| GV | GAS VALVE | OAT | OUTDOOR AIR TEMP. SEN | T1 | 1st STAGE OF COOLING CALL |
| HACR | HEATING, AIR-CONDITIONING, REFRIGERATION BREAKER | OFM | OUTDOOR FAN MOTOR | T2 | 2nd STAGE OF COOLING CALL |
| | | OFR | OUTDOOR FAN RELAY | | |

48TC004290 H

Typical Power Wiring Diagram for SystemVu™ Controller Units, 48FE 04-07, 460/575-3-60 Units Shown

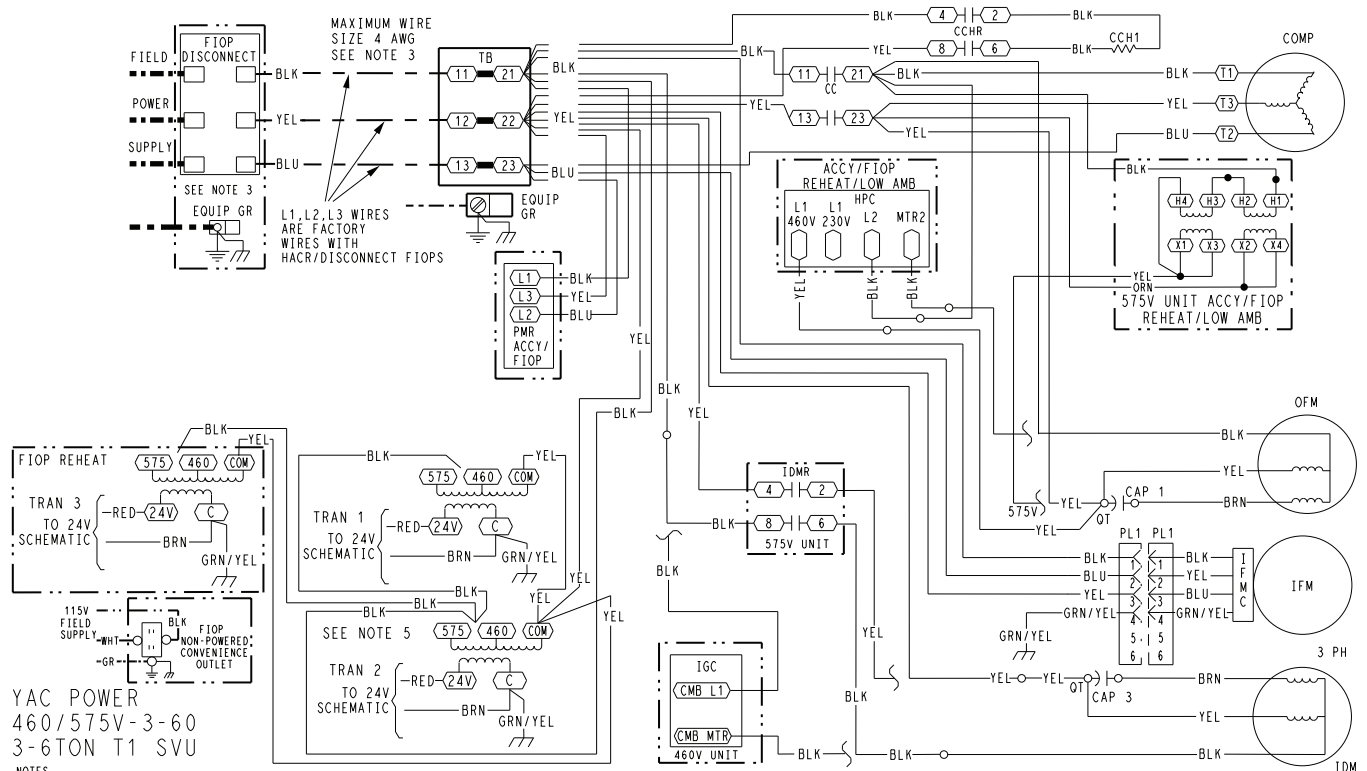

- NOTES
1. IF ANY OF THE ORIGINAL WIRE FURNISHED MUST BE REPLACED, IT MUST BE REPLACED WITH TYPE 90° C WIRE OR ITS EQUIVALENT.
 2. COMPRESSOR AND FAN MOTORS ARE THERMALLY PROTECTED.
 3. USE COPPER CONDUCTOR ONLY.
 4. DO NOT DISCONNECT POWER PLUG OR SIGNAL WIRE WHILE UNDER LOAD.
 5. TRANSFORMER IS DEDICATED BASED ON UNIT VOLTAGE. TAPS ONLY SHOWN TO SIMPLIFY SCHEMATIC.

LEGEND

- (X) MARKED WIRE
- (X) TERMINAL (MARKED)
- TERMINAL (UNMARKED)
- [X] TERMINAL BLOCK
- SPLICE
- SPLICE (MARKED)
- FACTORY WIRING
- - - FIELD CONTROL WIRING
- · - · - FIELD POWER WIRING
- · · · · CIRCUIT BOARD TRACE
- · - · - ACCESSORY OR OPTIONAL WIRING

ACCY	ACCESSORY	HGRH	HOT GAS REHEAT	PER	POWER EXHAUST RELAY
AUX	AUXILIARY	HPC	HEAD PRESSURE CONTROL	PH	PHASE
AWG	AMERICAN WIRE GAGE	HPS	HIGH PRESSURE SWITCH	PL	PLUG ASSEMBLY
BA	BUILDING AUTOMATION NETWORK	HR	HEATER RELAY	POT	POTENTIOMETER
CC	CONTACTOR, COMPRESSOR	HUM	HUMIDISTAT	PMR	PHASE MONITOR RELAY
C	COMMON	I	IGNITOR	PS	PRESSURE SWITCH
CAP	CAPACITOR	IAQ	INDOOR AIR QUALITY SENSORS	PWM	PULSE WIDTH MODULATION
CB	CIRCUIT BREAKER	IDM	INDUCED DRAFT MOTOR	QT	QUADRUPLE TERMINAL
CCH	CRANKCASE HEATER	IDMR	INDUCED DRAFT RELAY	R	THERMOSTAT POWER
CCHTS	CRANKCASE HEATER TEMP SWITCH	IFM	INDOOR FAN MOTOR	RAT	RETURN AIR TEMP. SENSOR
CLO	COMPRESSOR LOCKOUT	IFMC	INDOOR FAN MOTOR CONTROL	RDB	REFRIGERANT DISSIPATION BOARD
CLV	COOLING LIQUID VALVE	IFO	INDOOR FAN ON SIGNAL	RDS	REFRIGERANT DISSIPATION SENSOR
CMB	CENTRIFUGAL MOTOR BLOWER	IGC	INTEGRATED GAS CONTROL	RDV	REHEAT DISCHARGE VALVE
COFS	CONDENSATE OVERFLOW SWITCH	I	IGNITOR	RH	RELATIVE HUMIDITY
COM	SIGNAL COMMON	IRH	INDOOR RELATIVE HUMIDITY	RLV	REHEAT LIQUID VALVE
COMP	COMPRESSOR MOTOR	JMP	JUMPER	RNET	LOCAL ACCESS NETWORK
DDC	DIRECT DIGITAL CONTROL	L1	LINE 1	RS	ROLLOUT SWITCH
DFB	DEFROST BOARD	LA	LOW AMBIENT LOCKOUT	RVS	REVERSING VALVE SOLENOID
DFT	DEFROST THERMOSTAT	LAR	LOW AMBIENT RELAY	SAT	SUPPLY AIR TEMP SENSOR
EHR	ELECTRIC HEAT RELAY	LAS	LOW AMBIENT SWITCH	SDP	SYSTEM DISCHARGE PRESSURE
ENTH	ENTHALPY	LCR	COMPRESSOR LOADER	SPRH	SPACE RELATIVE HUMIDITY
EQUIP	EQUIPMENT	LEN	LOCAL EQUIPMENT NETWORK	SPT	SPACE TEMPERATURE SENSOR
ERV	ENERGY RECOVERY VENTILATOR	LOC	LOSS OF CHARGE	SPTO	SPACE TEMPERATURE OFFSET
ESL	ENTHALPY SENSOR - LOW	LOOP PWR	CURRENT LOOP POWER	SSP	SYSTEM SUCTION PRESSURE
FB	FUSE BLOCK	LPS	LOW PRESSURE SWITCH	STD	STANDARD
FIOP	FACTORY INSTALLED OPTION	LS	LIMIT SWITCH	SW	SWITCH
FPT	FREEZE PROTECTION THERMOSTAT	LSM	LIMIT SWITCH (MANUAL RESET)	TB	TERMINAL BLOCK
FS	FLAME SWITCH	LTL0	LOW TEMP LOCKOUT	TDR	TIME DELAY RELAY
FST	FAN HOUSING TEMP SENSOR	MDB	MAIN BASE BOARD	TRAN	TRANSFORMER
FU	FUSE	MOV	METAL OXIDE VARISTOR	UCB	UNIT CONTROL BOARD
G	THERMOSTAT FAN CALL	MTR	MOTOR	W1	1st STAGE OF HEATING CALL
GR(GND)	GROUND	OAO	OUTDOOR AIR QUALITY	W2	2nd STAGE OF HEATING CALL
GV	GAS VALVE	OAT	OUTDOOR AIR TEMP. SEN	Y1	1st STAGE OF COOLING CALL
HACR	HEATING, AIR-CONDITIONING, REFRIGERATION BREAKER	OFM	OUTDOOR FAN MOTOR	Y2	2nd STAGE OF COOLING CALL
HGRH	HOT GAS REHEAT	OFR	OUTDOOR FAN RELAY		
		OL	OVERLOAD		

48TC003008 G

Typical Control Wiring Diagram — Electromechanical with POL224 — 50FE 04-06 Units Shown

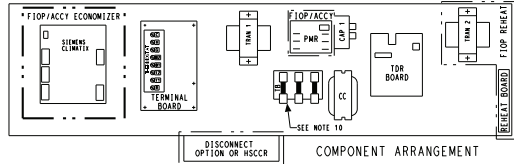

- NOTES:**
1. TERMINAL BOARD SCHEMATIC LAYOUT DOES NOT MATCH ACTUAL TERMINAL BOARD LAYOUT.
 2. TERMINAL BOARD JUMPERS 1, 2 AND 3 ARE CUT FOR REHEAT UNITS ONLY.
 3. REMOVE DESIGNATED JUMPERS ON TERMINAL BOARD WHEN ADDING SMOKE DETECTORS, OCCUPANCY AND REMOTE SHUTDOWN.
 4. USE ABC AS COURSE AND POT AS FINE ADJUSTMENTS FOR SETTING HIGH FAN SPEED. LOW SPEED IS AN OFFSET BASED ON DIP SWITCHES.
 5. 2-PIN LOW SPEED DIP SWITCH POSITIONS ARE FACTORY SET AS SHOWN.
 6. HANDBRAKE AND CUTOFF SET TO "MIN." JUMPER PIN ON TOP 2-PINS AS SHOWN.
 7. THE * WIRE COLOR IS FOR DIFFERENTIATION WITHIN THIS SCHEMATIC.
 8. TBA LOCATED IN HEAT SECTION.
 9. TO CONVERT TO A SINGLE STAGE HEATER MOVE VIOLET WIRE AT TBA TO CONNECT WITH WHITE WIRE.
 10. 3 PHASE UNIT SHOWN. ON 3 PHASE UNITS THIS IS A 3 POLE TERMINAL BLOCK.
 11. CONTROL BOARDS SHOWN HERE ARE IN THE UNPOWERED STATE.

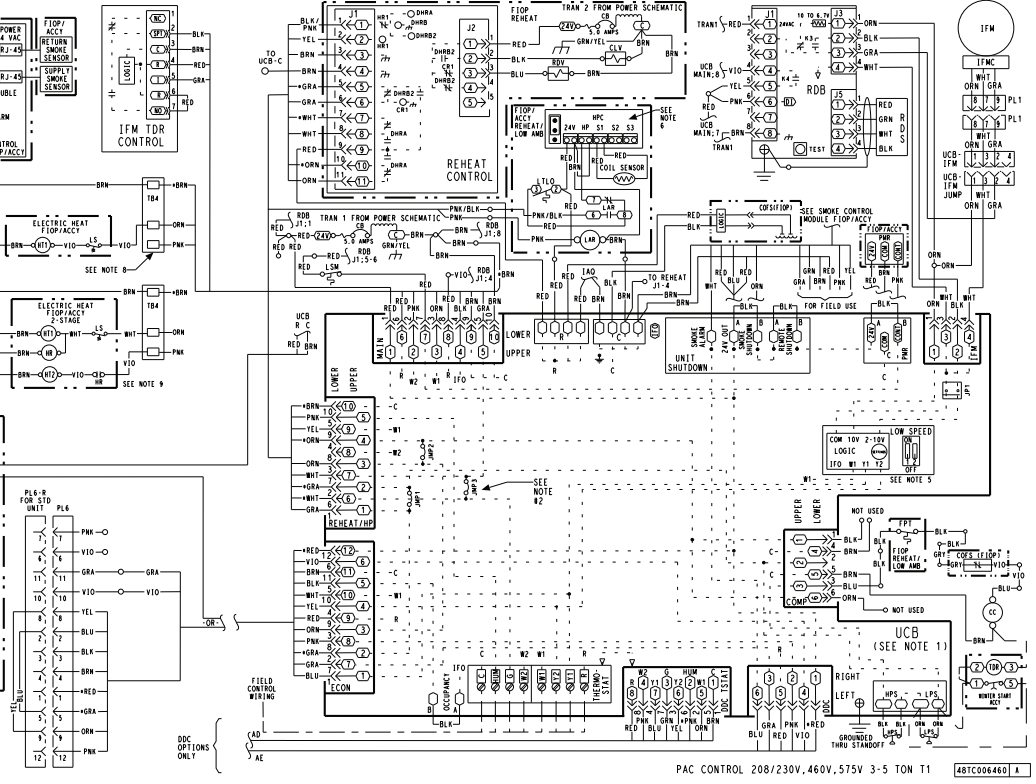
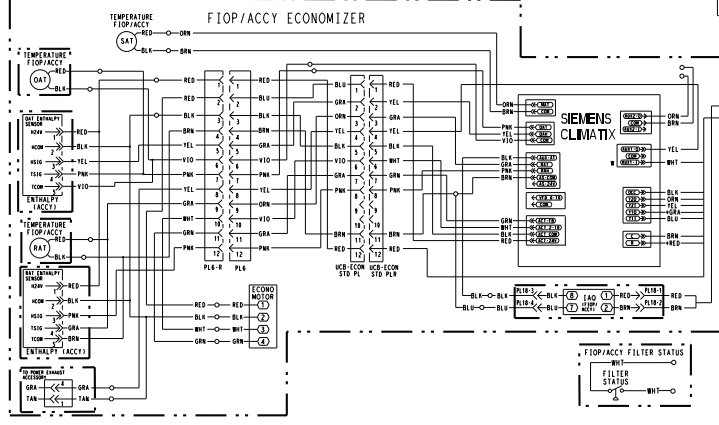
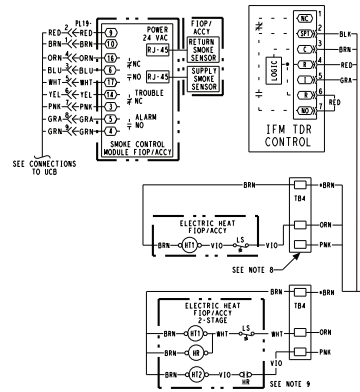

Typical Control Wiring Diagram — Electromechanical with POL224 — 50FE 07 Units Shown

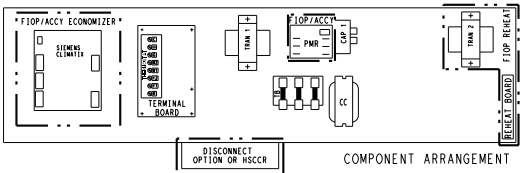

- NOTES:
1. TERMINAL BOARD SCHEMATIC LAYOUT DOES NOT MATCH ACTUAL TERMINAL BOARD LAYOUT.
 2. TERMINAL BOARD JUMPERS 1, 2 AND 3 ARE CUT FOR REHEAT UNITS ONLY.
 3. REMOVE DESIGNATED JUMPERS ON TERMINAL BOARD WHEN ADDING SMOKE DETECTORS, OCCUPANCY AND REMOTE SHUTDOWN.
 4. USE ABC AS COURSE AND POT AS FINE ADJUSTMENTS FOR SETTING HIGH FAN SPEED. LOW SPEED IS AN OFFSET BASED ON DIP SWITCHES.
 5. 2-PIN LOW SPEED DIP SWITCH POSITIONS ARE FACTORY SET AS SHOWN.
 6. HARDCUT AND CUTOFF SET TO "MIN". JUMPER PIN ON TOP 2-PINS AS SHOWN.
 7. THE * WIRE COLOR IS FOR DIFFERENTIATION WITHIN THIS SCHEMATIC.
 8. COMPRESSOR LOADER PLUG CONTAINS BRIDGE RECTIFIER TO CONVERT AC TO DC.
 9. T84 LOCATED IN HEAT SECTION.
 10. TO CONVERT TO A SINGLE STAGE HEATER MOVE VIOLET WIRE AT T84 TO CONNECT WITH WHITE WIRE.
 11. CONTROL BOARDS SHOWN HERE ARE IN THE UNPOWERED STATE.

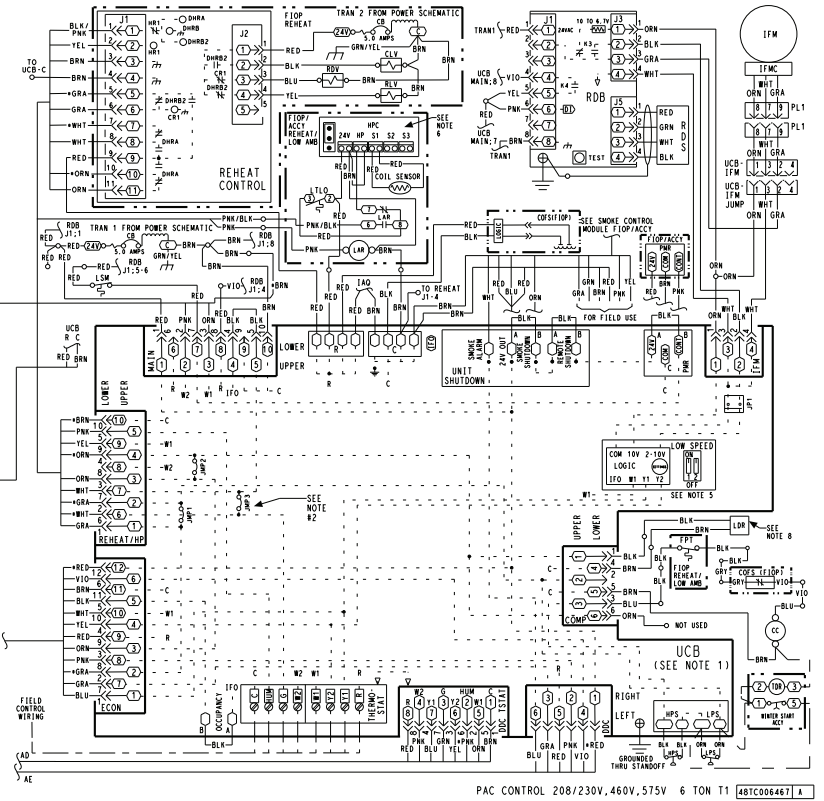
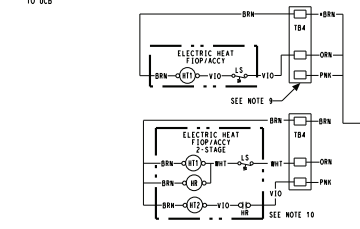
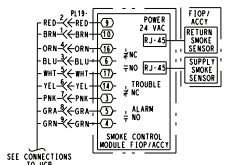

Typical wiring diagrams (cont)



Typical Control Wiring Diagram— SystemVu™ Controller —50FE 04-06 Unit Shown

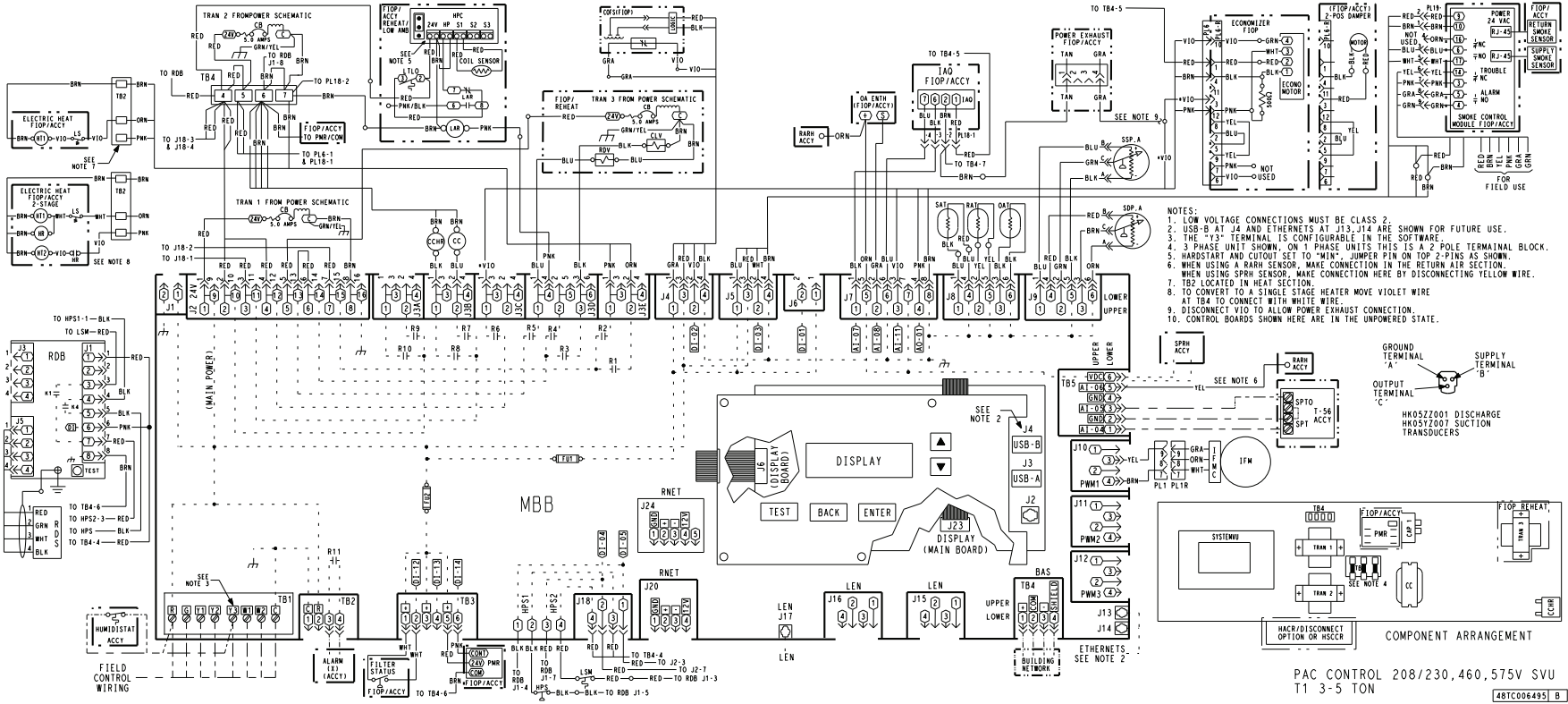

Typical Control Wiring Diagram— SystemVu™ Controller —50FE 07 Unit Shown

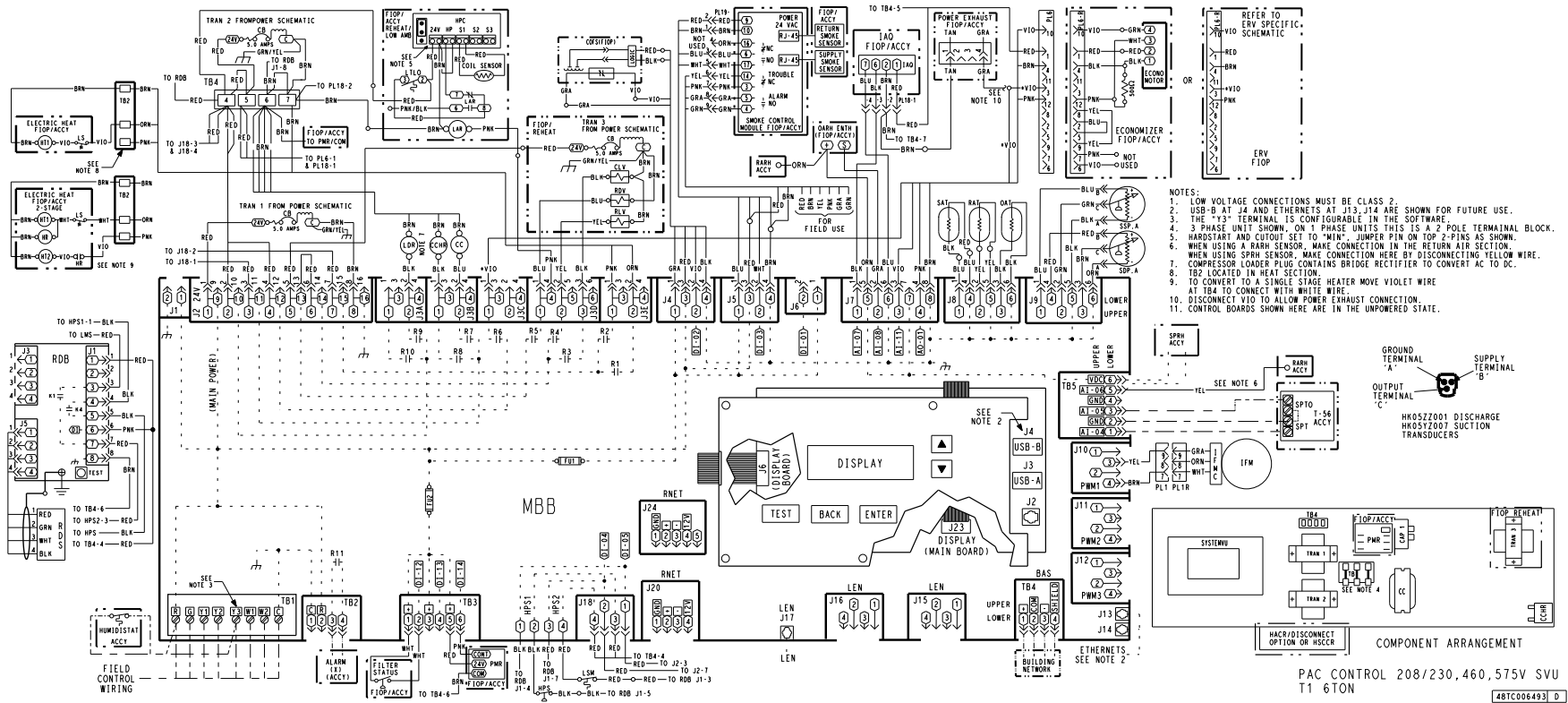

Typical 50FE 04-07 Power Wiring Diagram, 460/575-v Unit Shown

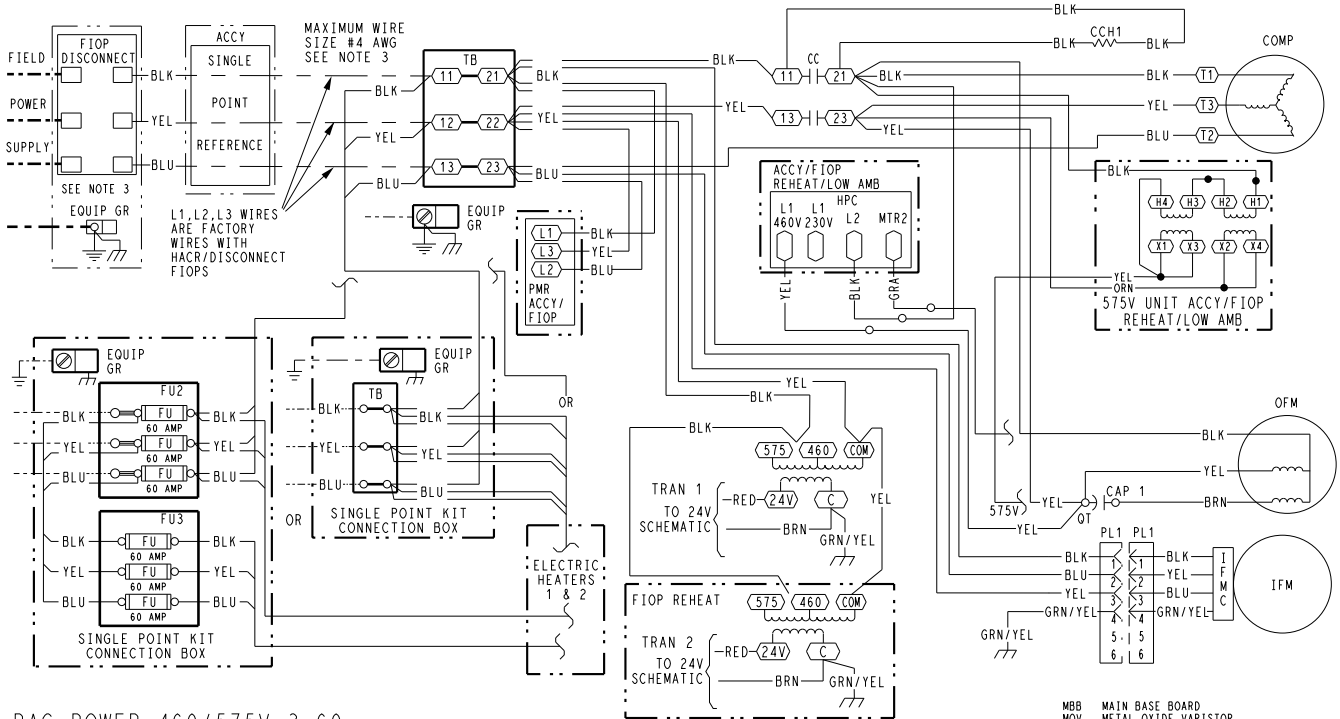

PAC POWER 460/575V-3-60
3-6TON T1

- NOTES**
- IF ANY OF THE ORIGINAL WIRE FURNISHED MUST BE REPLACED, IT MUST BE REPLACED WITH TYPE 90° C WIRE OR ITS EQUIVALENT.
 - COMPRESSOR AND FAN MOTORS ARE THERMALLY PROTECTED.
 - USE COPPER CONDUCTOR ONLY.
 - DO NOT DISCONNECT POWER PLUG OR SIGNAL WIRE WHILE UNDER LOAD.
 - TRANSFORMER IS DEDICATED BASED ON UNIT VOLTAGE. TAPS ONLY SHOWN TO SIMPLIFY SCHEMATIC.

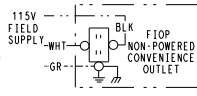

- LEGEND**
- (X) MARKED WIRE
 - (X) TERMINAL (MARKED)
 - () TERMINAL (UNMARKED)
 - (X) TERMINAL BLOCK
 - SPLICE
 - (●) SPLICE (MARKED)
 - FACTORY WIRING
 - - - FIELD CONTROL WIRING
 - - - FIELD POWER WIRING
 - - - CIRCUIT BOARD TRACE
 - - - ACCESSORY OR OPTIONAL WIRING
- | | | | | | |
|-------|------------------------------|----------|--------------------------------------------------|-----|---------------------------|
| ACCY | ACCESSORY | G | GROUND | TH | THERMOSTAT FAN CALL |
| AWG | AMERICAN WIRE GAGE | GR(GND) | GROUND | T | THERMOSTAT |
| BAS | BUILDING AUTOMATION NETWORK | HACR | HEATING, AIR-CONDITIONING, REFRIGERATION BREAKER | TRN | TRANSFORMER |
| CC | CONTACTOR, COMPRESSOR COMMON | HR | HEATER RELAY | UCB | UNIT CONTROL BOARD |
| C | COMMON | HGRH | HEATER RELAY | W1 | 1st STAGE OF HEATING CALL |
| CB | CIRCUIT BREAKER | HPC | HOT GAS REHEAT | W2 | 2nd STAGE OF HEATING CALL |
| CCH | CRANKCASE HEATER | HPS | HIGH PRESSURE SWITCH | Y1 | 1st STAGE OF COOLING CALL |
| CCHR | CRANKCASE HEATER RELAY | HUM | HUMIDISTAT | Y2 | 2nd STAGE OF COOLING CALL |
| CCHTS | CRANKCASE HEATER TEMP SWITCH | IAQ | INDOOR AIR QUALITY SENSORS | | |
| CLO | COMPRESSOR LOCKOUT | IFM | INDOOR FAN MOTOR | | |
| CLV | COOLING LIQUID VALVE | IFMC | INDOOR FAN MOTOR CONTROL | | |
| COFS | CONDENSATE OVERFLOW SWITCH | IFO | INDOOR FAN ON SIGNAL | | |
| COM | SIGNAL COMMON | IRH | INDOOR RELATIVE HUMIDITY | | |
| COMP | COMPRESSOR MOTOR | JMP | JUMPER | | |
| DDC | DIRECT DIGITAL CONTROL | L1 | LINE 1 | | |
| DFB | DEFROST BOARD | LA | LOW AMBIENT LOCKOUT | | |
| DFT | DEFROST THERMOSTAT | LAR | LOW AMBIENT RELAY | | |
| EHR | ELECTRIC HEAT RELAY | LAS | LOW AMBIENT SWITCH | | |
| ENTH | ENTHALPY | LDR | COMPRESSOR LOADER | | |
| ERV | ENERGY RECOVERY VENTILATOR | LEN | LOCAL EQUIPMENT NETWORK | | |
| ESL | ENTHALPY SENSOR - LOW | LOC | LOSS OF CHARGE | | |
| FB | FUSE BLOCK | LOOP PWR | CURRENT LOOP POWER | | |
| FIOF | FACTORY INSTALLED OPTION | LPS | LOW PRESSURE SWITCH | | |
| FPT | FREEZE PROTECTION THERMOSTAT | LS | LIMIT SWITCH | | |
| FST | FAN HOUSING TEMP SENSOR | LSM | LIMIT SWITCH (MANUAL RESET) | | |
| FU | FUSE | LTO | LOW TEMP LOCKOUT | | |

48TC002995 H

Typical Power Wiring Diagram for SystemVu™ Controller Units, 50FE 04-07, 460/575-3-60 Units Shown

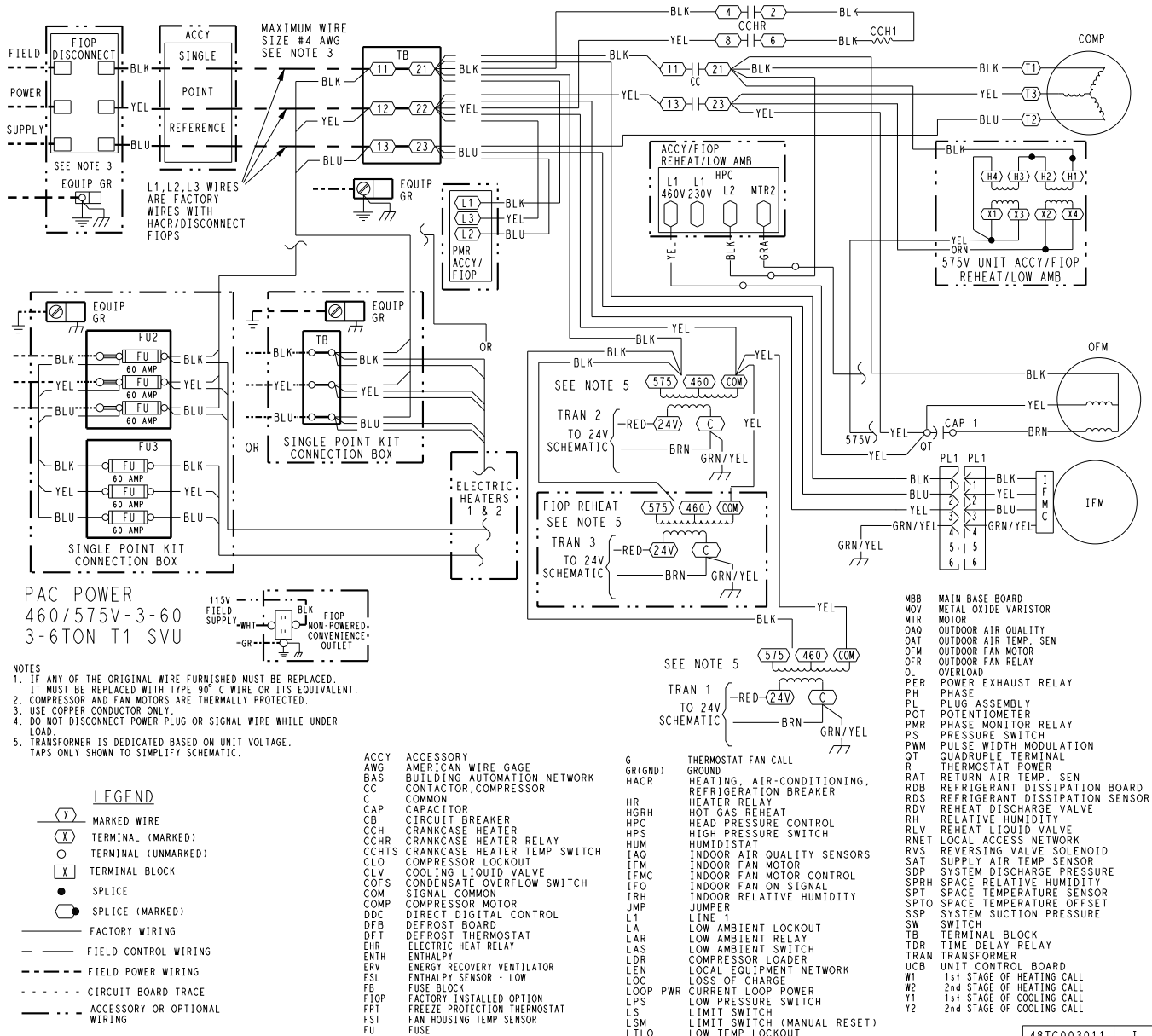

48TC003011 I

General

The sequence below describes the sequence of operation for an electromechanical unit with and without a factory-installed EconomizerONE (POL224 controller). For information regarding a direct digital controller, see the start-up, operations, and troubleshooting manual for the applicable controller.

Dissipation

When the factory-installed dissipation system detects a level of refrigerant leak in the unit, a safety dissipation mode will be activated. During this dissipation mode, the thermostat will be disabled and the indoor fan will run at 66% of the maximum speed of the motor. When the refrigerant leak levels are normal for 5 minutes, the unit will return to normal operation.

Electromechanical units without economizer

Cooling (single stage units)

When the thermostat calls for cooling, terminals G and Y1 are energized. The indoor fan will run at the user-set fan speed and the compressor contactor (CC) is energized, causing the compressor and outdoor fan to run.

When the thermostat removes the call for Y1, the compressor contactor will de-energize, shutting down the compressor and the outdoor fan. When the thermostat removes the call for G, the indoor fan will turn off after the specific unit fan off delay.

Cooling (2-stage units)

When the thermostat calls for cooling, terminals G and Y1 are energized. The indoor fan will run at the low fan speed and the compressor contactor (CC) is energized, causing the compressor and outdoor fan to run. The low indoor fan speed is 66% of the user-set fan speed, and the compressor will run at partial capacity.

If additional cooling is needed, then the thermostat will add the call for Y2. This will increase the indoor fan speed to the user-set fan speed and energize the compressor loader for full compressor capacity. The outdoor fan is the same speed for Y1 and Y2.

When the thermostat removes the call for Y2 but leaves the Y1, the indoor fan will reduce speed to 66% of the user-set fan speed, the compressor loader will turn off, and the outdoor fan will remain on. When the thermostat removes the call for Y1, the compressor contactor will de-energize, shutting down the compressor and the outdoor fan. When the thermostat removes the call for G, the indoor fan will turn off after the specific unit fan off delay.

NOTE: Per ASHRAE 90.1-2016 and IECC-2018 standards, during the first stage of cooling operation, the Unit Control Board (UCB) will adjust the fan motor speed to provide 66% of the total cfm established for the unit.

Gas heating (48FE units)

NOTE: WeatherMaker® units have either 1 or 2 stages of gas heat.

When the thermostat calls for heating, power is sent to W on the Integrated Gas Controller (IGC) board. An LED (light-emitting diode) on the IGC board turns on and remains on during normal operation. A check is made to ensure that the roll-out switch and limit switch are closed. If the check was successful, then the induced draft motor is

energized, and when its speed is satisfactory, as proven by the flue gas pressure switch, the ignition activation period begins. The burners will ignite within 5 seconds. If the burners do not light, then there is a 22-second delay before another 5-second attempt. This sequence is repeated for 15 minutes or until the burners light. If, after the 15 minutes, the burners still have not lit, heating is locked out. To reset the control, break 24-v power to the thermostat.

When ignition occurs, the IGC board will continue to monitor the condition of the roll-out switch, the limit switches, the flue gas pressure switch, and the flame sensor. Forty-five seconds after ignition occurs, assuming the unit is controlled through a room thermostat set for fan auto, the indoor-fan motor will energize (and the outdoor-air dampers will open to their minimum position). If, for some reason, the over-temperature limit opens prior to the start of the indoor fan blower, then the unit will shorten the 45 second delay to 5 seconds less than the time from initiation of heat to when the limit tripped. Gas will not be interrupted to the burners and heating will continue. Once the fan-on delay has been modified, it will not change back to 45 seconds until power is reset to the control. On units with 2 stages of heat, when additional heat is required, W2 closes and initiates power to the second stage of the main gas valve. When the thermostat is satisfied, W1 and W2 open and the gas valve closes, interrupting the flow of gas to the main burners. If the unit is controlled through a room thermostat set for fan auto, then the indoor fan motor will continue to operate for an additional 45 second and then stop. An LED indicator is provided on the IGC to monitor operation.

Electric heating (50FE units)

NOTE: 50FE units are sold as cooling only. If electric heaters are required, use only factory-approved heaters. They will operate as follows.

Units have either 1 or 2 stages of electric heat. When the thermostat calls for heating, power is applied to G and the W1 terminals at the unit. The unit control will energize the indoor fan contactor and the first stage of electric heat. On units with 2-stage heating, when additional heating is required, the second stage of electric heat (if equipped) will be energized when power is applied at the W2 terminal on the unit.

IMPORTANT: The thermostat must be configured for Electric Heat so it will energize G with the W1 call.

Electromechanical units with factory-installed EconomizerONE

When free cooling is not available, the compressors will be controlled by the zone thermostat. When free cooling is available, the outdoor-air damper is modulated by the EconomizerONE control to provide a 50°F (10°C) to 55°F (13°C) mixed-air temperature into the zone. As the mixed air temperature fluctuates above 55°F (13°C) or below 50°F (10°C), dampers will be modulated (open or close) to bring the mixed-air temperature back within control. If mechanical cooling is utilized with free cooling, then the outdoor-air damper will maintain its current position at the time the compressor is started. If the increase in cooling capacity causes the mixed-air temperature to drop below 45°F (7°C), then the outdoor-air damper position will be decreased to the minimum position. If the mixed-air temperature continues to fall, then the outdoor-air damper will

close. Control returns to normal once the mixed-air temperature rises above 48°F (9°C). The power exhaust fans will be energized and de-energized, if installed, as the outdoor-air damper opens and closes.

If field-installed accessory CO₂ sensors are connected to the EconomizerONE control, then a demand-controlled ventilation strategy will begin to operate. As the CO₂ level in the zone increases above the CO₂ setpoint (on the EconomizerONE controller), the minimum position of the damper will be increased proportionally until the Maximum Ventilation setting is reached. As the CO₂ level decreases because of the increase in fresh air, the outdoor-air damper will follow the higher demand condition from either the DCV mode or from the free cooling mode. For EconomizerONE operation, there must be a thermostat call for the fan (G). If the unit is occupied and the fan is on, then the damper will operate at minimum position. Otherwise, the damper will be closed.

When the EconomizerONE control is in the occupied mode and a call for cooling exists (Y1 on the thermostat), the control will first check for indoor fan operation. If the fan is not on, then cooling will not be activated. If the fan is on, then the control will open the EconomizerONE damper to the minimum position.

On the initial power to the EconomizerONE control, it will take the damper up to 2-1/2 minutes before it begins to position itself. After the initial power-up, further changes in damper position can take up to 90 seconds to initiate. Damper movement from fully closed to fully open (or vice versa) will take between 1-1/2 and 2-1/2 minutes. If free cooling can be used, as determined from the appropriate changeover command (dry bulb, outdoor enthalpy, differential dry bulb, or differential enthalpy), then the control will modulate the dampers open and closed to maintain the mixed-air temperature setpoint at 50°F (10°C) to 55°F (13°C). If there is a further demand for cooling (cooling second stage — Y2 is energized), then the control will bring on compressor stage 1 to maintain the mixed-air temperature setpoint. The EconomizerONE damper will be open at maximum position.

NOTE: For 2-speed units, the EconomizerONE controller will adjust the damper position as the Indoor Fan Speed changes, per its configured values.

Heating

The sequence of operation for heating is the same as for an electromechanical unit without an economizer. The only difference is how the economizer acts. The economizer will stay at the Economizer Minimum Position while the evaporator fan is operating. The outdoor-air damper is closed when the indoor fan is not operating. Refer to the unit's service and maintenance manual for further details.

Optional Humidi-MiZer® dehumidification system

Units with the factory-installed Humidi-MiZer system option are capable of providing multiple modes of improved dehumidification as a variation of the normal cooling cycle. The Humidi-MiZer system includes additional valves in the liquid line and discharge line of each refrigerant circuit, a small reheat condenser coil downstream of the evaporator, and variable-speed control of some or all outdoor fans. Operation of the revised refrigerant circuit for each mode is described below.

The Humidi-MiZer system provides 3 sub-modes of operation: Cool, Reheat1, and Reheat2.

Cool — provides a normal ratio of sensible and latent cooling effect from the evaporator coil.

Reheat1 — provides increased latent cooling while slightly reducing the sensible cooling effect.

Reheat2 — provides normal latent cooling but with null or minimum sensible cooling effect delivered to the space.

The Reheat1 and Reheat2 modes are available when the unit is not in a heating mode and when the low ambient lockout switch is closed.

Refer to the figures that follow for single stage and 2 stage piping flow diagrams.

SystemVu™ controller (factory option)

For details on operating 48/50FE units equipped with the factory-installed SystemVu controller option, refer to the *FE/GÉ Series Single Package Rooftop Units with SystemVu Controller Controls, Start-Up, Operation and Troubleshooting* manual.

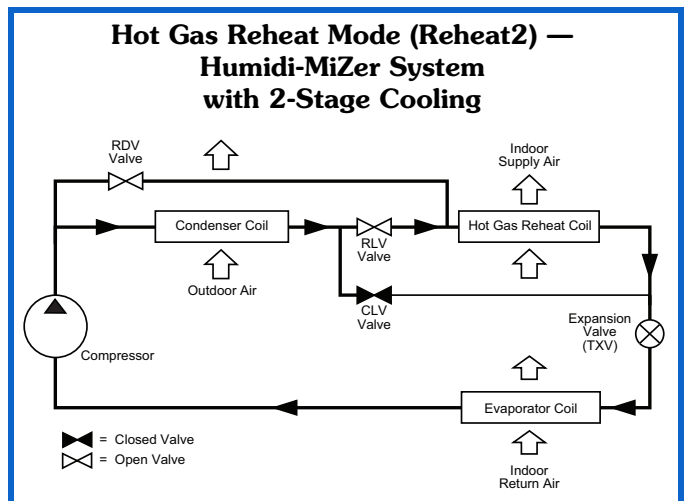
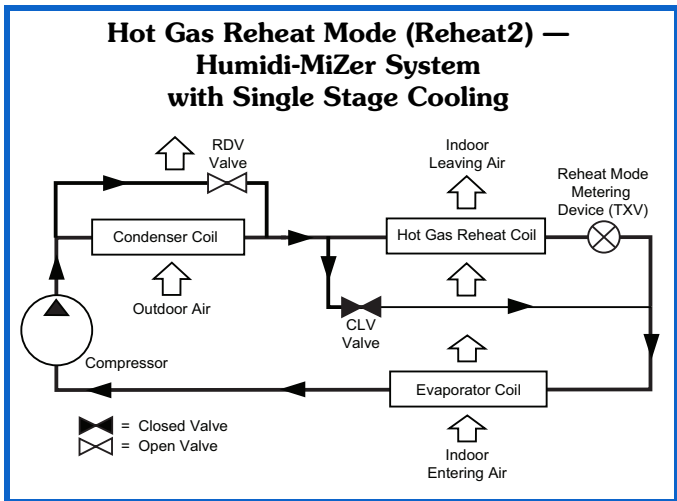
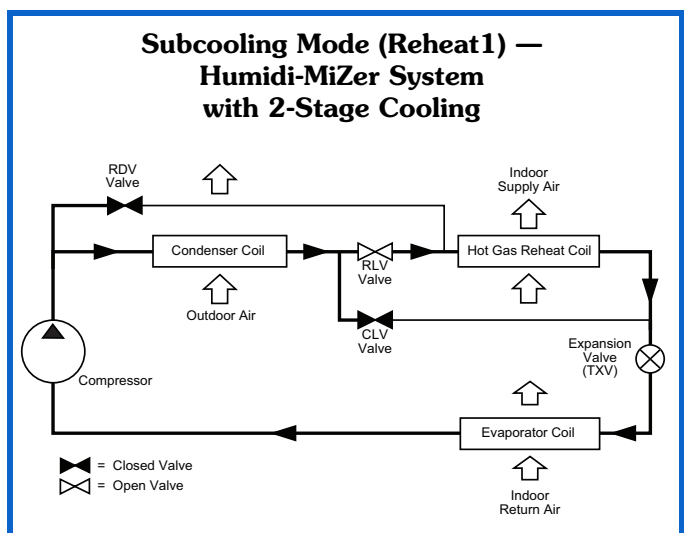
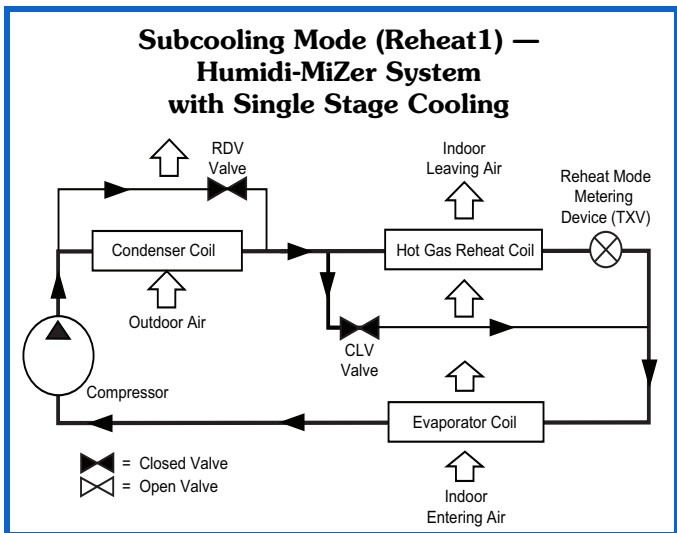
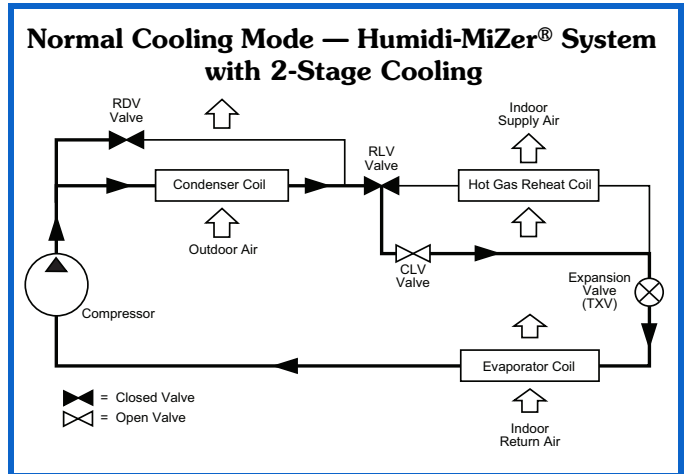
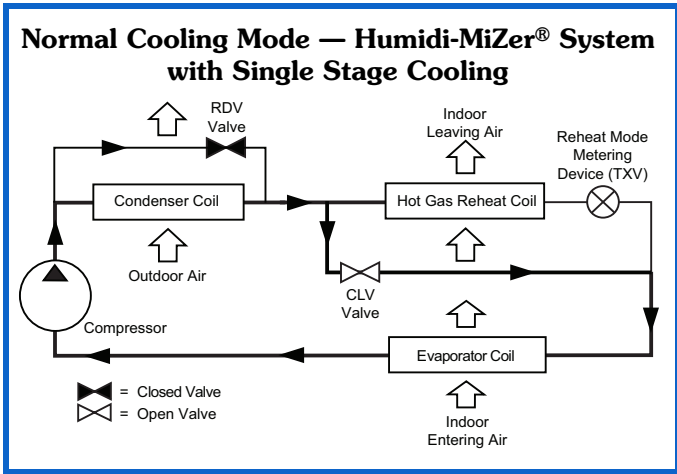

Minimum operating ambient temperature (cooling)

In mechanical cooling mode, your Carrier rooftop unit can safely operate down to an outdoor ambient temperature of 40°F (4°C). It is possible to provide cooling at lower outdoor ambient temperatures by using less outside air, economizers, and/or accessory low ambient kits.

Maximum operating ambient temperature (cooling)

The maximum operating ambient temperature for cooling mode is 115°F (46°C). While cooling operation above 115°F (46°C) may be possible, it could cause reduced performance, reduced reliability, or a protective action by the unit's internal safety devices.

Multiple motor and drive packages

Some applications need larger horsepower motors, some need more airflow, and some need both. Regardless of the case, your Carrier expert has a factory-installed combination to meet your application. A wide selection of motors are available, factory installed, to handle nearly any application.

Stainless steel heat exchanger (48FE units only)

For this option, the tubular heat exchanger is made out of a minimum 20 gauge type 409 stainless steel for applications where the mixed air to the heat exchanger is expected to drop below 45°F (7°C). Stainless steel may be specified on applications where the presence of airborne contaminants require its use (applications such as paper mills) or in area with very high outdoor humidity that may result in severe condensation in the heat exchanger during cooling operation.

Minimum mixed air temperature (heating) (48FE units only)

Using the factory settings, the minimum temperatures for mixed air (the combined temperature of the warm return air and the cold outdoor air) entering the dimpled gas heat exchangers are shown in the following table.

Minimum Temperature for Mixed Air Temperature

ALUMINIZED	STAINLESS STEEL
50°F (10°C) Continuous	40°F (4°C) Continuous
45°F (7°C) Intermittent	35°F (2°C) Intermittent

Operating at lower mixed-air temperatures may be possible, if a field-supplied outdoor-air thermostat initiates both heat stages when the temperature is less than the minimum temperatures listed above. Please contact your local Carrier representative for assistance.

Minimum and maximum airflow (heating and cooling)

To maintain safe and reliable operation of your rooftop, operate within the heating airflow limits during heating mode and cooling airflow limits during cooling mode. Operating above the maximum may cause blow-off, undesired airflow noise, or airflow-related problems with the rooftop unit. Operating below the minimum may cause problems with coil freeze-up and unsafe heating operation. Heating and cooling limitations differ when evaluating

operating cfm. The minimum value is the HIGHER of the cooling and heating minimum cfm values published on page 9 and the maximum value is the LOWER of the cooling and heating minimum values published on page 10.

Heating-to-cooling changeover

Your unit will automatically change from heating to cooling mode when using a thermostat with an auto-changeover feature.

Airflow

All units are draw-through in cooling mode and blow-through in heating mode.

Outdoor air application strategies

Economizers reduce operating expenses and compressor run time by providing a free source of cooling and a means of ventilation to match changing needs. In fact, they should be considered for most applications. Also, consider the various economizer control methods and their benefits, as well as the sensors required to accomplish your application goals. Please contact your local Carrier representative for assistance.

Motor limits, brake horsepower (bhp)

Due to the internal design of Carrier units, the air path, and specially designed motors, the full horsepower (maximum continuous bhp) band, as listed in the Fan Performance tables, can be used with the utmost confidence. There is no need for extra safety factors, as Carrier motors are designed and rigorously tested to use the entire listed bhp range without either nuisance tripping or premature motor failure.

Propane heating (48FE units only)

Propane has different physical qualities than natural gas. As a result, propane requires a different fuel to air mixture. To optimize the fuel/air mixture for propane, Carrier sells different burner orifices in an easy-to-install accessory kit. To select the correct burner orifices or determine the heat capacity for a propane application, use either the selection software or the unit's service manual.

NOTE: Not available for 48FE Ultra Low NOx units.

High altitude heating

High altitudes have less oxygen, which affects the fuel/air mixture in heat exchangers. In order to maintain a proper fuel/air mixture, heat exchangers operating at altitudes above 2,000 ft (610 m) require different orifices. To select the correct burner orifices or determine the heat capacity for a high altitude application, use either the selection software or the unit's service manual.

High altitudes have less oxygen, which means heat exchangers need less fuel. The new gas orifices in Carrier's field-installed kit make the necessary adjustment for high altitude applications. They restore the optimal fuel to air mixture and maintain healthy combustion at altitudes above 2,000 ft (610 m).

NOTE: Typical natural gas heating value ranges from 975 to 1050 Btu/ft³ at sea level nationally. The heating value goes down approximately 1.7% per every thousand feet of elevation. Standard factory orifices can typically be used up to 2,000 ft (610 m) elevation without any operational issues.

NOTE: Ultra Low NOx units can operate at altitudes of 0 to 7,800 feet standard. A high altitude conversion kit is

Application data (cont)



not necessary. Operation above 7,800 feet (2377 m) is not allowed. For every 1,000 feet above 2,000 feet, apply the following derate value for Ultra Low NOx units based on unit heat size:

ULTRA LOW NO _x UNIT HEAT SIZE	DERATE VALUE
60,000 BTU/hr	2.9%
82,000 BTU/hr	2.7%

Sizing a rooftop

Bigger is not necessarily better — while an air conditioner needs to have enough capacity to meet the design loads, it does not need excess capacity. In fact, excess capacity typically results in very poor part load performance and humidity control.

Using higher design temperatures than ASHRAE recommends for your location and adding “safety factors” to the calculated load are both signs of oversizing. Oversizing an air conditioner leads to poor humidity control, reduced efficiency, higher utility bills, larger indoor temperature swings, excessive noise, and increased wear and tear on the air conditioner.

Rather than oversizing an air conditioner, engineers should “right-size” or even slightly “under-size” air conditioners. Correctly sizing an air conditioner controls humidity better, promotes efficiency, reduces utility bills, extends equipment life, and maintains even, comfortable temperatures. Please contact your local Carrier representative for assistance.

Low ambient applications

The optional Carrier economizer can adequately cool your space by bringing in fresh, cool outside air. In fact, when a unit is equipped with an economizer, an accessory low-ambient kit may not be necessary. In low ambient conditions, unless the outdoor air is excessively humid or contaminated, economizer-based “free cooling” is the preferred, less costly, and energy-conscious method. In low ambient applications where outside air might not be desired (such as contaminated or excessively humid outdoor environments), your Carrier rooftop can operate to ambient temperatures down to -20°F (-29°C) using the recommended accessory low ambient controller.

Note about this specification:

This specification is in the “Masterformat” as published by the Construction Specification Institute. Please feel free to copy this specification directly into your building spec.



Gas Heat/Electric Cooling Packaged Rooftop

HVAC Guide Specifications

Size Range: **3 to 6 Nominal Tons**

Carrier Model Number: **48FE*04-07**

Part 1 — (23 06 80) Schedules for Decentralized HVAC Equipment

1.01 (23 06 80.13) Decentralized Unitary HVAC Equipment Schedule

- A. (23 06 80.13.A.) Rooftop Unit (RTU) Schedule:
Schedule is per the project specification requirements.

Part 2 — (23 07 16) HVAC Equipment Insulation

2.01 (23 07 16.13) Decentralized, Rooftop Units:

- A. (23 07 16.13.A.) Evaporator Fan Compartment:
1. Interior cabinet surfaces shall be insulated with a minimum 1/2 in. thick, minimum 1-1/2 lb density, flexible fiberglass insulation bonded with a phenolic binder, neoprene coated on the air side.
 2. Insulation and adhesive shall meet NFPA 90A requirements for flame spread and smoke generation.
- B. (23 07 16.13.B.) Gas Heat Compartment:
1. Aluminum foil-faced fiberglass insulation shall be used.
 2. Insulation and adhesive shall meet NFPA 90A requirements for flame spread and smoke generation.

Part 3 — (23 09 13) Instrumentation and Control Devices for HVAC

3.01 (23 09 13.23) Sensors and Transmitters

- A. (23 09 13.23.A.) Thermostats:
1. Thermostat must:
 - a. energize both “W” and “G” when calling for heat.
 - b. have capability to energize 1 or 2 stages of cooling, and 2 different stages of heating.
 - c. include capability for occupancy scheduling.

Part 4 — (23 09 23) Direct Digital Control System for HVAC

4.01 (23 09 23.13) Decentralized, Rooftop Units:

- A. (23 09 23.13.A.) SystemVu™ intelligent integrated Direct Digital Control (DDC) shall provide:
1. Integrated unit operation for comfort cooling, heating ventilation as well as all monitoring, recording and reporting capabilities. Controller shall also provide diagnostics and alarms of abnormal unit operation through the controller. Controller shall have an intuitive user display and be able to be used in a standalone operation or via building automation system (BAS).
 2. Quick Unit Status LEDs of: Run — meaning all systems are go, ALERT — that indicates there is currently a non-critical issue with the unit, like filters need to be replaced and FAULT — that indicates the unit has a critical issue and will possibly shut down.
 3. Six large navigation keys for easy access. Navigation keys shall consist of: TEST, BACK, ENTER, and MENU along with UP and DOWN arrows.
 4. Full back lit user display with 4 line by 30 character text capabilities. Display menu shall be designed to provide guided major menus and sub menus main menu provided below:
 - a. Shutdown Unit
 - b. Run Status
 - c. Settings
 - d. Alerts/Faults
 - e. Service
 - f. Inputs
 - g. Outputs
 - h. USB
 5. The capability for standalone operation with conventional thermostat/sensor or use with building automation systems (BAS) of Carrier i-Vu®, BACnet™¹, and Carrier Comfort Network® (CCN) systems. No special modules or boards are required for these capabilities. Has the capability to work with Equipment Touch™ and System Touch™ devices and ZS Sensors.
 6. The ability to read refrigerant pressures at display or via BAS network of; Discharge Pressure and Suction Pressure. The need for traditional refrigerant gauges is not required.
 7. USB Data Port for flash drive interaction. This will allow the transfer of data for uploads, downloads, perform software upgrades, back-up and restore data and file transfer data such as component number of starts and run hours.

1. Third-party trademarks and logos are the property of their respective owners.

8. Reverse Rotation Protection of compressors if field 3-phase wiring is misapplied.
9. Provide Service Capabilities of:
 - a. Auto run test
 - b. Manual run test
 - c. Component run hours and starts
 - d. Commissioning reports
 - e. Data logging
 - f. Alarm history
10. Economizer control and diagnostics. Set up economizer operation, receive feedback from actuator. Also meets the most recent California Title 24, ASHRAE 90.1 and IECC^{®1} Fault Detection and Diagnostic (FDD) requirements.
11. Unit cooling operation down to 40°F (4°C).
12. Controller shall have easy access connections around the controller perimeter area and consist of Mate-N-Lok^{®1}, terminal block and RJ style modular jack connections.
13. 365 day real time clock, 20 holiday schedules along with occupied and unoccupied scheduling.
14. Auto-recognition for easy installation and commissioning of devices like economizers, space sensors etc.
15. A 5°F (3°C) temperature difference between cooling and heating setpoints to meet the latest ASHRAE 90.1 Energy Standard.
16. Contain return air sensor, supply air sensor and outdoor air sensor to help monitor and provide data for the unit comfort operation, diagnostic and alarms.
17. Use of Carrier's field accessory Equipment Touch and System Touch devices.
18. Units with the factory-installed Humidi-MiZer[®] system option are capable of providing multiple modes of improved dehumidification as a variation of the normal cooling cycle.
19. Supply Air Tempering control operates the gas or electric heat to maintain a minimum supply air temperature during conditions where very cold outdoor air causes the supply air temperature to fall below the configured Supply Air Tempering Setpoint. This occurs during periods where DCV is active and increasing the amount of outdoor air or in cases where the system is operating at very low airflow and the calculated economizer position has increased to maintain a constant ventilation rate.
20. Demand limiting in SystemVu[™] is achieved through setpoint expansion. The systems heating and cooling setpoints are expanded in steps

or levels. The degree to which the setpoints may be expanded is defined by the 6 demand level offsets and the 2 commanded demand limit levels.

21. 3-year limited part warranty.

Part 5 — (23 09 33) Electric and Electronic Control System for HVAC

5.01 (23 09 33.13) Decentralized, Rooftop Units:

A. (23 09 33.13.A.) General:

1. Shall be complete with self-contained low-voltage control circuit protected by a resettable circuit breaker on the 24-v transformer side. Transformer shall have 75 VA capability.
2. Shall utilize color-coded wiring.
3. Shall include a Unit Control Board to conveniently and safely provide connection points for vital control functions such as: smoke detectors, phase monitor, gas controller, economizer, thermostat, DDC control options, and low and high pressure switches. Controller shall also provide an intuitive means to adjust the indoor fan speed through a simple switch and pot adjustment design.
4. The heat exchanger shall be controlled by an integrated gas controller (IGC) microprocessor. See heat exchanger section of this specification.
5. Unit shall include a minimum of one 8-pin screw terminal connection board for connection of control wiring.

B. (23 09 33.13.B.) Safeties:

1. Compressor over-temperature, over-current. High internal pressure differential.
2. Low Pressure Switch:
Low pressure switch shall use different color wire than the high pressure switch. The purpose is to assist the installer and service technician to correctly wire and or troubleshoot the rooftop unit.
3. High Pressure Switch:
High pressure switch shall use different color wire than the low pressure switch. The purpose is to assist the installer and service technician to correctly wire and or troubleshoot the rooftop unit.
4. Automatic reset, motor thermal overload protector.
5. Heating section shall be provided with the following minimum protections:
 - a. High temperature limit switches.
 - b. Induced draft motor pressure switch.
 - c. Flame rollout switch.
 - d. Flame proving controls.

1. Third-party trademarks and logos are the property of their respective owners.

6. A2L Refrigerant Leak Dissipation System (Electromechanical):
 - a. Leak dissipation system shall consist of control board and A2L sensor certified to UL-60335-2-40.
 - b. System shall be designed for the life of the unit.
 - c. Dissipation system shall be automatic, ship pre-wired, and require no additional field connections to thermostat to function.
 - d. Refrigerant leak sensor shall be installed in UL-certified location and orientation. Sensor shall be self-correcting and resettable. Single use refrigerant leak sensor shall not be permitted.
 - e. Factory-installed dissipation controller shall use onboard microprocessor and include:
 - 1) Automatic reset after a dissipation event has occurred.
 - 2) Onboard LED with flash code to indicate current unit status and hardware failures.
 - 3) Depressible “Test” button to allow for a system test and recall/reset of leak detection history.
 - 4) 24-v dry contact alarm terminal to allow for external notification of leak detection.
 - f. Dissipation control board shall be accessible via normal maintenance locations and LED shall be visible.
 - g. Dissipation system shall “Fail Safe” per UL requirements.
 - h. Dissipation shall allow smoke and building fire systems to override in case of event.
 7. A2L Refrigerant Leak Dissipation System (SystemVu):
 - a. Leak dissipation system shall consist of control board and A2L sensor certified to UL-60335-2-40, integrated with SystemVu controller.
 - b. System shall be designed for the life of the unit.
 - c. Dissipation system shall be automatic, ship pre-wired, and require no additional field connections to function.
 - d. Refrigerant leak sensor shall be installed in UL-certified location and orientation. Sensor shall be self-correcting and resettable. Single use refrigerant leak sensor shall not be permitted.
 - e. Factory-installed dissipation system shall use onboard microprocessor and include:
 - 1) Automatic leak detection and dissipation algorithm.
 - 2) Automatic reset after a dissipation event has occurred.
 - 3) Onboard LED with flash code to indicate current unit status and hardware failures.
 - 4) Depressible “Test” button to allow for a system test and recall/reset of leak detection history.
 - 5) 24-v dry contact alarm terminal on dissipation control board to allow for external notification of leak detection.
 - 6) Ability to notify BAS system of dissipation event via readable alarm point through SystemVu.
 - 7) Recallable dissipation alarm history on SystemVu controller.
 - f. Dissipation control board shall be accessible via normal maintenance locations and LED shall be visible.
 - g. Dissipation system shall “Fail Safe” per UL requirements.
 - h. Dissipation shall allow smoke and building fire systems to override in case of event.
- Part 6 — (23 09 93) Sequence of Operations for HVAC Controls**
- 6.01 (23 09 93.13) Decentralized, Rooftop Units:
 - A. (23 09 93.13.A.) INSERT SEQUENCE OF OPERATION
- Part 7 — (23 40 13) Panel Air Filters**
- 7.01 (23 40 13.13) Decentralized, Rooftop Units:
 - A. (23 40 13.13.A.) Standard Filter Section:
 1. Shall consist of factory installed, low velocity, disposable 2 in. thick fiberglass filters of commercially available sizes.
 2. Unit shall use only one filter size. Multiple sizes are not acceptable.
 3. Filters shall be accessible through an access panel with “no-tool” removal as described in the unit cabinet section of this specification (23 81 19.13.G).
- Part 8 — (23 81 19) Self-Contained Air Conditioners**
- 8.01 (23 81 19.13) Small-Capacity Self-Contained Air Conditioners:
 - A. (23 81 19.13.A.) General:
 1. Outdoor, rooftop mounted, electrically controlled, heating and cooling unit utilizing a fully hermetic scroll compressor(s) for cooling duty and gas combustion for heating duty.
 2. Factory assembled, single-piece heating and cooling rooftop unit. Contained within the unit enclosure shall be all factory wiring, piping, controls, and special features required prior to field start-up.
 3. Unit shall use Puron Advance™ (R-454B) refrigerant.
 4. Unit shall be installed in accordance with the manufacturer’s instructions.

5. Unit must be selected and installed in compliance with local, state, and federal codes.
- B. (23 81 19.13.B.) Quality Assurance:
1. Unit meets DOE and ASHRAE 90.1 minimum efficiency requirements.
 2. Unit shall be rated in accordance with AHRI Standards 210/240 (04-06 sizes) or 340/360 (07 size).
 3. Unit shall be designed to conform to ASHRAE 15.
 4. Unit shall be UL-tested and certified in accordance with ANSI Z21.47 Standards and UL-listed and certified under Canadian standards as a total package for safety requirements.
 5. Insulation and adhesive shall meet NFPA 90A requirements for flame spread and smoke generation.
 6. Unit casing shall be capable of withstanding 500 hour salt spray exposure per ASTM B117 (scribed specimen).
 7. Unit shall be designed in accordance with ISO 9001, and shall be manufactured in a facility registered by ISO 9001:2015.
 8. Roof curb shall be designed to conform to NRCA Standards.
 9. Unit shall be subjected to a completely automated run test on the assembly line. The data for each unit will be stored at the factory, and must be available upon request.
 10. Unit shall be designed in accordance with UL Standards 60335-1 and 60335-2-40, including testing to withstand rain. Unit shall be IPX4 rated.
 11. Unit shall be constructed to prevent intrusion of snow and tested to prevent snow intrusion into the control box up to 40 mph.
 12. Unit shake tested to assurance level 1, ASTM D4169 to ensure shipping reliability.
- C. (23 81 19.13.C.) Delivery, Storage, and Handling:
1. Unit shall be stored and handled per manufacturer's recommendations.
 2. Lifted by crane requires either shipping top panel or spreader bars.
 3. Unit shall only be stored or positioned in the upright position.
- D. (23 81 19.13.D.) Project Conditions:
1. As specified in the contract.
- E. (23 81 19.13.E.) Operating Characteristics:
1. Unit shall be capable of starting and running at 115°F (46°C) ambient outdoor temperature, meeting maximum load criteria of AHRI Standard 210/240 or 340/360 at ±10% voltage.
 2. Compressor with standard controls shall be capable of operation down to 40°F (4°C) ambient outdoor temperatures.
 3. Unit shall discharge supply air vertically or horizontally as shown on contract drawings.
 4. Unit shall be factory configured for vertical supply and return configurations.
 5. Unit shall be field convertible from vertical to horizontal airflow on all models. No special kit required.
 6. Unit shall be capable of mixed operation: vertical supply with horizontal return or horizontal supply with vertical return.
- F. (23 81 19.13.F.) Electrical Requirements:
1. Main power supply voltage, phase, and frequency must match those required by the manufacturer.
- G. (23 81 19.13.G.) Unit Cabinet:
1. Unit cabinet shall be constructed of galvanized steel, and shall be bonderized and coated with a prepainted baked enamel finish on all externally exposed surfaces.
 2. Unit cabinet exterior paint shall be: film thickness, (dry) 0.003 inches minimum, gloss (per ASTM D523, 60°F/16°C): 60, Hardness: H-2H Pencil hardness.
 3. Evaporator fan compartment interior cabinet insulation shall conform to AHRI Standards 210/240 and or 340/360 minimum exterior sweat criteria. Interior surfaces shall be insulated with a minimum 1/2 in. thick, 1 lb density, flexible fiberglass insulation, neoprene coated on the air side. Aluminum foil-faced fiberglass insulation shall be used in the heat compartment.
 4. Base of unit shall have a minimum of 4 locations for thru-the-base gas and electrical connections (factory-installed or field-installed), standard.
 5. Base Rail:
 - a. Unit shall have base rails on a minimum of 2 sides.
 - b. Holes shall be provided in the base rails for rigging shackles to facilitate maneuvering and overhead rigging.
 - c. Holes shall be provided in the base rail for moving the rooftop by fork truck.
 - d. Base rail shall be a minimum of 16 gauge thickness.
 6. Condensate Pan and Connections:
 - a. Shall be a sloped condensate drain pan made of a corrosion resistant material.
 - b. Shall comply with ASHRAE Standard 62.
 - c. Shall use a 3/4 in. 14 NPT drain connection, possible either through the bottom or

side of the drain pan. Connection shall be made per manufacturer's recommendations.

7. Top Panel:
a. Shall be a single piece top panel on all sizes.

8. Gas Connections:

- a. All gas piping connecting to unit gas valve shall enter the unit cabinet at a single location on side of unit (horizontal plane).
- b. Thru-the-base capability:
- 1) Standard unit shall have a thru-the-base gas-line location using a raised, embossed portion of the unit basepan.
 - 2) Optional, factory approved, water-tight connection method must be used for thru-the-base gas connections.
 - 3) No basepan penetration, other than those authorized by the manufacturer, is permitted.

9. Electrical Connections:

- a. All unit power wiring shall enter unit cabinet at a single, factory prepared, knockout location.
- b. Thru-the-base capability:
- 1) Standard unit shall have a thru-the-base electrical location(s) using a raised, embossed portion of the unit basepan.
 - 2) Optional, factory approved, water-tight connection method must be used for thru-the-base electrical connections.
 - 3) No basepan penetration, other than those authorized by the manufacturer, is permitted.

10. Component Access Panels (standard):

- a. Cabinet panels shall be easily removable for servicing.
- b. Unit shall have one factory installed, tool-less, removable, filter access panel.
- c. Panels covering control box, indoor fan, indoor fan motor, gas components (where applicable), and compressors shall have molded composite handles.
- d. Handles shall be UV modified, composite. They shall be permanently attached, and recessed into the panel.
- e. Screws on the vertical portion of all removable access panel shall engage into heat resistant, molded composite collars.
- f. Collars shall be removable and easily replaceable using manufacturer recommended parts.

H. (23 81 19.13.H.) Gas Heat:

1. General:

- a. Heat exchanger shall be an induced draft design. Positive pressure heat exchanger designs shall not be allowed.

- b. Shall incorporate a direct-spark ignition system and redundant main gas valve.
- c. Gas supply pressure at the inlet to the rooftop unit gas valve must match that required by the manufacturer.

2. The heat exchanger shall be controlled by an integrated gas controller (IGC) microprocessor.

- a. IGC board shall notify users of fault using an LED (light-emitting diode).
- b. The LED shall be visible without removing the control box access panel.
- c. IGC board shall contain algorithms that modify evaporator fan operation to prevent future cycling on high temperature limit switch.
- d. Unit shall be equipped with anti-cycle protection with one short cycle on unit flame rollout switch or 4 continuous short cycles on the high temperature limit switch. Fault indication shall be made using an LED.

3. Standard Heat Exchanger Construction:

- a. Heat exchanger shall be of the tubular-section type constructed of a minimum of 20-gauge steel coated with a nominal 1.2 mil aluminum-silicone alloy for corrosion resistance.
- b. Burners shall be of the in-shot type constructed of aluminum-coated steel.
- c. Burners shall incorporate orifices for rated heat output up to 2,000 ft (610 m) elevation. Additional accessory kits may be required for applications above 2,000 ft (610 m) elevation, depending on local gas supply conditions.
- d. Each heat exchanger tube shall contain multiple dimples for increased heating effectiveness.

4. Optional Stainless Steel Heat Exchanger Construction:

- a. Use energy saving, direct-spark ignition system.
- b. Use a redundant main gas valve.
- c. Burners shall be of the in-shot type constructed of aluminum-coated steel.
- d. All gas piping shall enter the unit cabinet at a single location on side of unit (horizontal plane).
- e. The optional stainless steel heat exchanger shall be of the tubular-section type, constructed of a minimum of 20-gauge type 409 stainless steel.
- f. Type 409 stainless steel shall be used in heat exchanger tubes and vestibule plate.
- g. Complete stainless steel heat exchanger allows for greater application flexibility.

5. Optional Low NO_x Heat Exchanger Construction:
 - a. Low NO_x reduction shall be provided to reduce nitrous oxide emissions to be 40 nanograms per joule or less.
 - b. Primary tubes and vestibule plates on low NO_x units shall be 409 stainless steel. Other components shall be aluminized steel.
6. Standard Stainless Steel Heat Exchanger Construction — Ultra Low NO_x Burner Box:
 - a. Burners shall be of the premixed type constructed of stainless steel.
 - b. Shall use a redundant main gas valve.
 - c. Burners shall be of the in-shot type constructed of aluminum-coated steel.
 - d. All gas piping shall enter the unit cabinet at a single location on side of unit (horizontal plane).
 - e. The stainless steel heat exchanger shall be of the tubular-section type, constructed of a minimum of 20-gauge type 409 stainless steel.
 - f. Type 409 stainless steel shall be used in heat exchanger tubes and vestibule plate.
 - g. Stainless Steel natural gas burner box and heat exchanger assembly shall provide Ultra Low NO_x gas emissions of 14 nanograms/joule (ng/j).
7. Induced Draft Combustion Motor and Blower:
 - a. Shall be a direct-drive, single inlet, forward-curved centrifugal type.
 - b. Shall be made from steel with a corrosion resistant finish.
 - c. Shall have permanently lubricated sealed bearings.
 - d. Shall have inherent thermal overload protection.
 - e. Shall have an automatic reset feature.
- I. (23 81 19.13.I.) Coils:
 1. Standard Aluminum Fin-Copper Tube Coils:
 - a. Standard evaporator and condenser coils shall have aluminum lanced plate fins mechanically bonded to seamless internal helically grooved copper tubes with all joints brazed.
 - b. Evaporator coils shall be leak tested to 150 psig, pressure tested to 450 psig, and qualified to UL 60335-2-40 burst test at 1775 psig.
 - c. Condenser coils shall be leak tested to 150 psig, pressure tested to 650 psig, and qualified to UL 60335-2-40 burst test at 1980 psig.
 2. Optional Pre-coated Aluminum-Fin Condenser Coils (3-Phase Models Only):
 - a. Shall have a durable epoxy-phenolic coating to provide protection in mildly corrosive coastal environments.
 - b. Coating shall be applied to the aluminum fin stock prior to the fin stamping process to create an inert barrier between the aluminum fin and copper tube.
 - c. Epoxy-phenolic barrier shall minimize galvanic action between dissimilar metals.
 - d. Corrosion durability of fin stock shall be confirmed through testing to be no less than 1000 hours salt spray per ASTM B117.
 - e. Corrosion durability of fin stock shall be confirmed through testing to have no visible corrosion after 48 hour immersion in a room temperature solution of 5% salt, 1% acetic acid.
 - f. Fin stock coating shall pass 2000 hours of the following: one week exposure in the prohesion chamber followed by one week of accelerated ultraviolet light testing. Prohesion chamber: the solution shall contain 3.5% sodium chloride and 0.35% ammonium sulfate. The exposure cycle is one hour of salt fog application at ambient followed by one hour drying at 95°F (35°C).
 3. Optional Copper-Fin Evaporator and Condenser Coils (3-Phase Models Only):
 - a. Shall be constructed of copper fins mechanically bonded to copper tubes and copper tube sheets.
 - b. Galvanized steel tube sheets shall not be acceptable.
 - c. A polymer strip shall prevent coil assembly from contacting the sheet metal coil pan to minimize potential for galvanic corrosion between coil and pan.
 4. Optional E-coated Aluminum-Fin Evaporator and Condenser Coils (3-Phase Models Only):
 - a. Shall have a flexible epoxy polymer coating uniformly applied to all coil surface areas without material bridging between fins.
 - b. Coating process shall ensure complete coil encapsulation of tubes, fins and headers.
 - c. Color shall be high gloss black with gloss per ASTM D523.
 - d. Uniform dry film thickness from 0.8 to 1.2 mil on all surface areas including fin edges.
 - e. Superior hardness characteristics of 2H per ASTM D3363 and cross-hatch adhesion of 4B-5B per ASTM D3359.
 - f. Impact resistance shall be up to 160 in. lb (ASTM D2794).

- g. Humidity and water immersion resistance shall be up to minimum 1000 and 250 hours respectively (ASTM D2247 and ASTM D870).
 - h. Corrosion durability shall be confirmed through testing to be no less than 1000 hours salt spray per ASTM B117.
- J. (23 81 19.13.J.) Refrigerant Components:
- 1. Refrigerant circuit shall include the following control, safety, and maintenance features:
 - a. Fixed orifice metering system on 04-06 models and TXV on 07 size models shall include a multiple feed distribution system that optimizes coil performance.
 - b. Refrigerant filter drier, solid core design with pre and post-filter service gauge connections for filter diagnostics and maintenance.
 - c. Service gauge connections on suction and discharge lines.
 - d. Pressure gauge access through a specially designed access port in the top panel of the unit.
 - 2. There shall be gauge line access port in the skin of the rooftop, covered by a black, removable plug.
 - a. The plug shall be easy to remove and replace.
 - b. When the plug is removed, the gauge access port shall enable maintenance personnel to route their pressure gauge lines.
 - c. This gauge access port shall facilitate correct and accurate condenser pressure readings by enabling the reading with the compressor access panel on.
 - d. The plug shall be made of a leak proof, UV-resistant, composite material.
 - 3. Compressors:
 - a. Unit shall use fully hermetic scroll compressors.
 - b. Compressor motors shall be cooled by refrigerant gas passing through motor windings.
 - c. Compressors shall be internally protected from high discharge temperature conditions.
 - d. Compressors shall be protected from an over-temperature and over-ampereage conditions by an internal, motor overload device.
 - e. Compressor shall be factory mounted on rubber grommets.
 - f. Compressor motors shall have internal line break thermal, current overload and high pressure differential protection.
 - g. Crankcase heaters shall not be required for normal operating range, unless required by compressor manufacturer due to refrigerant charge limits.
- h. Compressor on 04-06 models shall be of a single stage cooling capacity design and 07 models shall be a 2 stage cooling capacity design.
- K. (23 81 19.13.K.) Filter Section:
- 1. Filters access is specified in the unit cabinet section of this specification.
 - 2. Filters shall be held in place by a pivoting filter tray, facilitating easy removal and installation.
 - 3. Shall consist of factory installed, low velocity, throw-away 2 in. thick fiberglass filters.
 - 4. Filters shall be standard, commercially available sizes.
 - 5. Only one size filter per unit is allowed.
- L. (23 81 19.13.L.) Evaporator Fan and Motor with EcoBlue™ Technology:
- 1. Direct Drive Evaporator fan motor:
 - a. Shall be an ECM motor design.
 - b. Shall be direct drive design for all static options.
 - c. Shall have permanently lubricated bearings.
 - d. Shall have inherent automatic-reset thermal overload protection.
 - e. Shall have slow ramp-up to speed capabilities.
 - f. Shall require no fan/motor belts for operation, adjustments and or initial fan speed setup.
 - g. Fan DC voltage set up on Unit Control Board shall eliminate the need of removal of blower access door, required on conventional belt drive systems.
 - h. Shall be internally protected from electrical phase reversal.
 - 2. Evaporator Fan:
 - a. Speed shall be easily set with dedicated selection switch and adjustment pot on unit control board or through SystemVu™ controller.
 - b. On sizes 04-06 single speed indoor fan operation provided and on 07 size model with 2 stage cooling capacity control, the indoor fan speed is automatically controlled to meet the code-compliant 66% low fan speed and 100% at full fan speed operation.
 - c. Blower fan shall be a vane axial fan design with fan assembly secured directly to ECM motor. Additional shafts, belts, pulleys/sheaves, and bearing blocks to drive fan shall not be permitted or necessary.
 - d. Additional variable frequency drive to control fan motor speed shall not be permitted or necessary. All speed control electronics must be on board fan motor assembly.

- e. Shall be constructed of an aluminum stator or high impact composite material on stator, rotor and air inlet casing.
 - f. Shall be a patented / pending design with a corrosion resistant material.
 - g. Fan assembly design shall be integrated into fan deck, dynamically balanced, and require no additional vibration isolation for normal operation.
 - h. Shall have slow ramp-up to speed capabilities to help reduce sound and comfort issues typically associated with single speed belt drive systems.
 - i. Shall be a slide out design with 2 screw removal.
3. Shall include an easily accessible Unit Control Board to conveniently and safely provide connection points for vital control functions such as: smoke detectors, phase monitor, gas controller, economizer, thermostat, DDC control options, and low and high pressure switches. Controller shall also provide an intuitive means to adjust the indoor fan speed through a simple switch and pot adjustment design.
- M. (23 81 19.13.M.) Condenser Fans and Motors:
- 1. Condenser Fan Motors:
 - a. Shall be a totally enclosed motor.
 - b. Shall use permanently lubricated bearings.
 - c. Shall have inherent thermal overload protection with an automatic reset feature.
 - d. Shall use a shaft-down design on all sizes.
 - 2. Condenser Fans:
 - a. Shall be a direct-driven propeller type fan constructed of high impact composite material.
 - b. Shall have high impact composite blades completely formed into one piece without blade fasteners or connectors and shall be dynamically balanced.
- N. (23 81 19.13.N.) Special Features Options and Accessories:
- 1. Integrated EconomizerONE and EconoMi\$er2 Low Leak Rate Models.
 - a. Integrated, gear driven opposing modulating blade design type capable of simultaneous economizer and compressor operation.
 - b. Independent modules for vertical or horizontal return configuration shall be available. Vertical return modules shall be available as a factory-installed option.
 - c. Damper blades shall be galvanized steel with composite gears. Plastic or composite blades on intake or return shall not be acceptable.
 - d. Shall include all hardware and controls to provide free cooling with outdoor air when temperature and/or humidity are below setpoints.
 - e. Shall be equipped with gear driven dampers for both the outdoor ventilation air and the return air for positive air stream control.
 - f. Low leak rate shall be equipped with dampers not to exceed 2% leakage at 1 in. wg pressure differential.
 - g. Economizer controller on EconomizerONE models shall be the Siemens POL224 that provides:
 - 1) Combined minimum and DCV maximum damper position potentiometers with compressor staging relay.
 - 2) Optional configuration via WLAN stick and Siemens Climatix™1 smartphone app for easy setup.
 - 3) Functions with solid-state analog enthalpy or dry bulb changeover control sensing.
 - 4) LED indication for free cooling, sensor, and damper operation.
 - 5) One-line LCD interface screen for setup, configuration, and troubleshooting.
 - 6) On-board Fault Detection and Diagnostics (FDD) that senses and alerts when the economizer is not operating properly, per California Title 24, ASHRAE 90.1 and IECC.
 - 7) Sensor failure loss of communication identification.
 - 8) Capabilities for use with multiple-speed or single speed indoor fan systems.
 - 9) Digital sensors: dry bulb and enthalpy.
 - h. Economizer controller on EconoMi\$er 2 models with SystemVu™ controllers shall be a 4 to 20mA design controlled directly by the controller. SystemVu controllers meet California Title 24, ASHRAE 90.1 and IECC Fault Detection and Diagnostic (FDD) requirements.
 - i. Shall be capable of introducing up to 100% outdoor air.
 - j. Shall be equipped with a barometric relief damper capable of relieving up to 100% return air and contain seals that meet ASHRAE 90.1 requirements.
 - k. Shall be designed to close damper(s) during loss-of-power situations with spring return built into motor.
 - l. Dry bulb outdoor air temperature sensor shall be provided as standard. Enthalpy sensor is also available factory installed only. Outdoor air sensor setpoint shall be adjustable and

1. Third-party trademarks and logos are the property of their respective owners.

- shall range from 40°F to 100°F (4°C to 38°C). Additional sensor options shall be available as accessories.
- m. The economizer controller shall also provide control of an accessory power exhaust unit function. Factory set at 100%, with a range of 0% to 100%.
 - n. The economizer shall maintain minimum air flow into the building during occupied period and provide design ventilation rate for full occupancy.
 - o. Dampers shall be completely closed when the unit is in the unoccupied mode.
 - p. Economizer controller shall accept a 0 to 10 vdc CO₂ sensor input for IAQ/DCV control. In this mode, dampers shall modulate the outdoor air damper to provide ventilation based on the sensor input.
 - q. Compressor lockout temperature on POL224 control is adjustable from -45°F to 80°F (-43°C to 26°C), set at a factory default of 32°F (0°C).
 - r. Actuator shall be direct coupled to economizer gear. No linkage arms or control rods shall be acceptable.
 - s. Contains LED indication for free cooling, sensor, and damper operations.
2. Integrated EconomizerONE and EconoMi\$er®2 Ultra Low Leak Rate Models.
 - a. Integrated, gear driven opposing modulating blade design type capable of simultaneous economizer and compressor operation.
 - b. Independent modules for vertical or horizontal return configuration shall be available. Vertical return modules shall be available as a factory-installed option.
 - c. Damper blades shall be galvanized steel with composite gears. Plastic or composite blades on intake or return shall not be acceptable.
 - d. Shall include all hardware and controls to provide free cooling with outdoor air when temperature and/or humidity are below setpoints.
 - e. Shall be equipped with gear driven dampers for both the outdoor ventilation air and the return air for positive air stream control.
 - f. Ultra Low Leak design meets California Title 24 section 140.4 and ASHRAE 90.1 requirements for 4 cfm per sq ft on the outside air dampers and 10 cfm per sq ft on the return dampers.
 - g. Economizer controller on EconomizerONE models shall be the Siemens POL224 that provides:
 - 1) One-line LCD interface screen for setup, configuration, and troubleshooting.
 - 2) Optional configuration via WLAN stick and Siemens Climatix™¹ smartphone app for easy setup.
 - 3) On-board Fault Detection and Diagnostics (FDD) that senses and alerts when the economizer is not operating properly, per California Title 24, ASHRAE 90.1 and IECC.
 - 4) Sensor failure loss of communication identification.
 - 5) Capabilities for use with multiple-speed indoor fan systems.
 - 6) Digital sensors: dry bulb and enthalpy.
 - h. Economizer controller on EconoMi\$er 2 models with SystemVu™ controllers shall be a 4 to 20 mA design controlled directly by the controller. SystemVu controllers meet California Title 24, ASHRAE 90.1 and IECC Fault Detection and Diagnostic (FDD) requirements.
 - i. Shall be capable of introducing up to 100% outdoor air.
 - j. Shall be equipped with a barometric relief damper capable of relieving up to 100% return air and contain seals that meet ASHRAE 90.1 requirements.
 - k. Shall be designed to close damper(s) during loss-of-power situations with spring return built into motor.
 - l. Dry bulb outdoor air temperature sensor shall be provided as standard. Enthalpy sensor is also available factory installed only. Outdoor air sensor setpoint shall be adjustable and shall range from 40°F to 100°F (4°C to 38°C). Additional sensor options shall be available as accessories.
 - m. The economizer controller shall also provide control of an accessory power exhaust unit function. Factory set at 100%, with a range of 0% to 100%.
 - n. The economizer shall maintain minimum air flow into the building during occupied period and provide design ventilation rate for full occupancy.
 - o. Dampers shall be completely closed when the unit is in the unoccupied mode.
 - p. Economizer controller shall accept a 0 to 10 vdc CO₂ sensor input for IAQ/DCV control. In this mode, dampers shall modulate the outdoor air damper to provide ventilation based on the sensor input.
 - q. Compressor lockout temperature on POL224 control is adjustable from -45°F to 80°F (-43°C to 26°C), set at a factory default of 32°F (0°C).

1. Third-party trademarks and logos are the property of their respective owners.

- r. Actuator shall be direct coupled to economizer gear. No linkage arms or control rods shall be acceptable.
 - s. Contains LED indication for free cooling, sensor, and damper operation.
3. Wi-Fi/WLAN Stick for EconomizerONE POL224 (field-installed):
This item allows for the use of the Siemens Climatix™ mobile application.
 4. Two-Position Damper (Field-installed only):
 - a. Damper shall be a Two-Position Damper. Damper travel shall be from the full closed position to the field adjustable %-open setpoint.
 - b. Damper shall include adjustable damper travel from 25% to 100% (full open).
 - c. Damper shall include single or dual blade, gear driven dampers and actuator motor.
 - d. Actuator shall be direct coupled to damper gear. No linkage arms or control rods shall be acceptable.
 - e. Damper will admit up to 100% outdoor air for applicable rooftop units.
 - f. Damper shall close upon indoor (evaporator) fan shutoff and/or loss of power.
 - g. The damper actuator shall plug into the rooftop unit's wiring harness plug. No hard wiring shall be required.
 - h. Outside air hood shall include aluminum water entrainment filter.
 5. Manual Damper (Field-installed only):
Manual damper package shall consist of damper, air inlet screen, and rain hood which can be preset to admit up to 25 or 50% outdoor air for year round ventilation.
 6. Humidi-MiZer® Adaptive Dehumidification System (3-Phase Models Only):
The Humidi-MiZer Adaptive Dehumidification System shall be factory installed and shall provide greater dehumidification of the occupied space by 2 modes of dehumidification operations in addition to its normal design cooling mode:
 - a. Subcooling mode further sub cools the hot liquid refrigerant leaving the condenser coil when both temperature and humidity in the space are not satisfied.
 - b. Hot gas reheat mode shall mix a portion of the hot gas from the discharge of the compressor with the hot liquid refrigerant leaving the condenser coil to create a 2-phase heat transfer in the system, resulting in a neutral leaving air temperature when only humidity in the space is not satisfied.
 - c. Includes low ambient controller.
 7. Low Ambient Control Package:
 - a. Controller shall control coil head pressure by condenser fan speed modulation or condenser fan cycling and wind baffles.
 - b. Shall consist of solid-state control and condenser coil temperature sensor to maintain condensing temperature between 90°F (32°C) and 110°F (43°C) at outdoor ambient temperatures down to -20°F (-29°C). For full low ambient control range, winter start kit is required.
 8. Propane Conversion Kit (not available on Ultra Low NOx units):
 - a. Package shall contain all the necessary hardware and instructions to convert a standard natural gas unit for use with liquefied propane, up to 2,000 ft (610 m) elevation.
 - b. Additional accessory kits may be required for applications above 2,000 ft (610 m) elevation.
 9. Flue Shield (not available on Ultra Low NOx units):
Flue shield shall provide protection from the hot sides of the gas flue hood.
 10. Condenser Coil Hail Guard Assembly (Factory-installed on 3-Phase Models Only. Field-installed on all 3 and 1-Phase Models.)
 - a. Shall protect against damage from hail.
 - b. Shall be either hood style or louvered.
 11. Unit-Mounted, Non-Fused Disconnect Switch (Available on units with MOCs of 80 amps or less):
 - a. Switch shall be factory installed, internally mounted.
 - b. National Electric Code (NEC) and UL approved non-fused switch shall provide unit power shutoff.
 - c. Shall be accessible from outside the unit.
 - d. Shall provide local shutdown and lockout capability.
 - e. Sized only for the unit as ordered from the factory. Does not accommodate field-installed devices.
 12. Convenience Outlet:
 - a. Factory-Installed Powered Convenience Outlet (3-Phase Models Only):
 - 1) Outlet shall be powered from main line power to the rooftop unit.
 - 2) Outlet shall be powered from line side or load side of disconnect by installing contractor, as required by code. If outlet is powered from load side of disconnect, unit electrical ratings shall be UL certified and rated for additional outlet amperage.

- 3) Outlet shall be factory-installed and internally mounted with easily accessible 115-v female receptacle.
 - 4) Outlet shall include 15 amp GFI receptacles with independent fuse protection.
 - 5) Voltage required to operate convenience outlet shall be provided by a factory installed step-down transformer.
 - 6) Outlet shall be accessible from outside the unit.
 - 7) Outlet shall include a field installed “Wet in Use” cover.
 - b. Factory-Installed Non-Powered Convenience Outlet:
 - 1) Outlet shall be powered from a separate 115/120-v power source.
 - 2) A transformer shall not be included.
 - 3) Outlet shall be factory-installed and internally mounted with easily accessible 115-v female receptacle.
 - 4) Outlet shall include 15 amp GFI receptacles with independent fuse protection.
 - 5) Outlet shall be accessible from outside the unit.
 - 6) Outlet shall include a field installed “Wet in Use” cover.
 - c. Field-Installed Non-Powered Convenience Outlet:
 - 1) Outlet shall be powered from a separate 115/120-v power source.
 - 2) A transformer shall not be included.
 - 3) Outlet shall be field-installed and internally mounted with easily accessible 115-v female receptacle.
 - 4) Outlet shall include 20 amp GFI receptacles. This kit provides a flexible installation method which allows code compliance for height requirements of the GFCI outlet from the finished roof surface as well as the capability to relocate the outlet to a more convenient location.
 - 5) Outlet shall be accessible from outside the unit.
 - 6) Outlet shall include a field installed “Wet in Use” cover.
13. Flue Discharge Deflector:
 - a. Flue discharge deflector shall direct unit exhaust vertically instead of horizontally.
 - b. Deflector shall be defined as a “natural draft” device by the National Fuel and Gas (NFG) code.
 14. Thru-the-Base Connectors:
 - a. Kits shall provide connectors to permit gas and electrical connections to be brought to the unit through the unit basepan.
 - b. Minimum of 4 connection locations per unit.
 15. Propeller Power Exhaust:
 - a. Power exhaust shall be used in conjunction with an integrated economizer.
 - b. Independent modules for vertical or horizontal return configurations shall be available.
 - c. Horizontal power exhaust shall be mounted in return ductwork.
 - d. Power exhaust shall be controlled by economizer controller operation. Exhaust fans shall be energized when dampers open past the 0 to 100% adjustable setpoint on the economizer control.
 16. Roof Curbs (Vertical):
 - a. Full perimeter roof curb with exhaust capability providing separate air streams for energy recovery from the exhaust air without supply air contamination.
 - b. Formed galvanized steel with wood nailer strip and shall be capable of supporting entire unit weight.
 - c. Permits installation and securing of ductwork to curb prior to mounting unit on the curb.
 17. High Altitude Gas Conversion Kit (not necessary on Ultra Low NOx units):

Package shall contain all the necessary hardware and instructions to convert a standard natural gas unit to operate from 2000 to 7000 ft (610 to 2134 m) elevation with natural gas or from 0 to 7000 ft (0 to 2134 m) elevation with liquefied propane.
 18. Outdoor Air Enthalpy Sensor:

The outdoor air enthalpy sensor shall be used to provide single enthalpy control. When used in conjunction with a return air enthalpy sensor, the unit will provide differential enthalpy control. The sensor allows the unit to determine if outside air is suitable for free cooling.
 19. Return Air Enthalpy Sensor:

The return air enthalpy sensor shall be used in conjunction with an outdoor air enthalpy sensor to provide differential enthalpy control.
 20. Indoor Air Quality (CO₂) Sensor:
 - a. Shall be able to provide demand ventilation indoor air quality (IAQ) control.
 - b. The IAQ sensor shall be available in duct mount, wall mount, or wall mount with LED display. The setpoint shall have adjustment capability.
 21. Smoke Detectors:
 - a. Shall be a 4-Wire Controller and Detector.

- b. Shall be environmentally compensated with differential sensing for reliable, stable, and drift-free sensitivity.
 - c. Shall use magnet-activated test/reset sensor switches.
 - d. Shall have tool-less connection terminal access.
 - e. Shall have a recessed momentary switch for testing and resetting the detector.
 - f. Controller shall include:
 - 1) One set of normally open alarm initiation contacts for connection to an initiating device circuit on a fire alarm control panel.
 - 2) Two Form-C auxiliary alarm relays for interface with rooftop unit or other equipment.
 - 3) One Form-C supervision (trouble) relay to control the operation of the Trouble LED on a remote test/reset station.
 - 4) Capable of direct connection to 2 individual detector modules.
 - 5) Can be wired to up to 14 other duct smoke detectors for multiple fan shut-down applications.
22. Winter Start Kit:
- a. Shall contain a bypass device around the low pressure switch.
 - b. Shall be required when mechanical cooling is required below 40°F (4°C).
 - c. Shall not be required to operate an economizer for cooling when below an outdoor ambient of 40°F (4°C).
 - d. Is not compatible with SystemVu controls.
23. Time Guard:
- a. Shall prevent compressor short-cycling by providing a 5-minute delay (± 2 minutes) before restarting a compressor after shut-down for any reason.
 - b. One device shall be required per compressor.
24. Hinged Access Panels:
- a. Shall provide easy access through integrated quarter turn latches.
 - b. Shall be on major panels of: filter, control box, fan motor, and compressor.
25. Condensate Overflow Switch:
- This sensor and related controller monitors the condensate level in the drain pan and shuts down compression operation when overflow conditions occur. It includes:
- a. Indicator light — solid red (more than 10 seconds on water contact — compressors disabled), blinking red (sensor disconnected).
 - b. 10 second delay to break — eliminates nuisance trips from splashing or waves in pan (sensor needs 10 seconds of constant water contact before tripping).
 - c. Disables the compressor(s) operation when condensate plug is detected, but still allows fans to run for economizer.
26. 4 in. MERV-13 Return Air Filters (factory-installed only):
- a. Factory option to upgrade standard unit filters to 4 in. MERV-13 filters.
 - b. Upgraded option shall include factory-installed 4 in. filter rack
 - c. Shall not be compatible with horizontal units with field installed economizers.
 - d. Shall not be compatible with size 04-06 units with Humidi-MiZer or any single phase units.
27. 4 in. Return Air Rack (field-installed only):
- a. Accessory kit is designed to hold 4 in. MERV-8 or MERV-13 filters. Filters not included in kit.
 - b. Shall not be compatible with horizontal units with field installed economizers.
 - c. Shall not be compatible with size 04-06 units with Humidi-MiZer.
28. 2 in. MERV-13 Return Air Filters:
- a. Accessory kit to field upgrade standard unit filters to 2 in. MERV-13 filters.
 - b. Correct size and quantity of filters shall ship in a single box.
29. 2 in. MERV-8 Return Air Filters:
- a. Accessory kit to field upgrade standard unit filters to 2 in. MERV-8 filters.
 - b. Correct size and quantity of filters shall ship in a single box.
30. Phase Monitor Control:
- a. Shall monitor the sequence of 3-phase electrical system to provide a phase reversal protection.
 - b. Shall monitor the 3-phase voltage inputs to provide a phase loss protection for the 3-phase device.
 - c. Will work on either a Delta or Wye power connection.
31. Horn/Strobe Annunciator:
- a. Provides an audible/visible signaling device for use with factory-installed option or field-installed accessory smoke detectors.
 - b. Requires installation of a field-supplied 24-v transformer suitable for 4.2 VA (AC) or 3.0 VA (DC) per horn/strobe accessory.
 - c. Requires field-supplied electrical box, North American 1-gang box, 2 in. (51 mm) x 4 in. (102 mm).

- d. Shall have a clear colored lens.
- 32. High Short Circuit Current Rating (SCCR) Protection:
 - a. Factory-installed option shall provide high short circuit current protection to compressor and all indoor and outdoor fan motors rated at 10 kA against high potential fault current situations. (Standard unit comes with 5 kA rating.)
 - b. This option is not available with factory-installed Ultra Low NO_x heater, HumidiMiZer, powered convenience outlet, non-fused disconnect, low ambient controls, phase loss monitor/protection, or 575-v models.

Note about this specification:

This specification is in the “Masterformat” as published by the Construction Specification Institute. Please feel free to copy this specification directly into your building spec.



Cooling Only/Electric Heat Packaged Rooftop

HVAC Guide Specifications

Size Range: **3 to 6 Nominal Tons**

Carrier Model Number: **50FE-04-07**

Part 1 — (23 06 80) Schedules for Decentralized HVAC Equipment

1.01 (23 06 80.13) Decentralized Unitary HVAC Equipment Schedule:

- A. (23 06 80.13.A.) Rooftop Unit (RTU) Schedule:
 - 1. Schedule is per the project specification requirements.

Part 2 — (23 07 16) HVAC Equipment Insulation

2.01 (23 07 16.13) Decentralized, Rooftop Units:

- A. (23 07 16.13.A.) Evaporator Fan Compartment:
 - 1. Interior cabinet surfaces shall be insulated with a minimum 1/2 in. thick, minimum 1-1/2 lb density, flexible fiberglass insulation bonded with a phenolic binder, neoprene coated on the air side.
 - 2. Insulation and adhesive shall meet NFPA 90A requirements for flame spread and smoke generation.
- B. (23 07 16.13.B.) Electric Heat Compartment:
 - 1. Aluminum foil-faced fiberglass insulation shall be used.
 - 2. Insulation and adhesive shall meet NFPA 90A requirements for flame spread and smoke generation.

Part 3 — (23 09 13) Instrumentation and Control Devices for HVAC

3.01 (23 09 13.23) Sensors and Transmitters:

- A. (23 09 13.23.A.) Thermostats:
 - 1. Thermostat must:
 - a. energize both “W” and “G” when calling for heat.
 - b. have capability to energize 1 or 2 stages of cooling, and 2 different stages of heating.
 - c. include capability for occupancy scheduling.

Part 4 — (23 09 23) Direct Digital Control System for HVAC

4.01 (23 09 23.13) Decentralized, Rooftop Units:

- A. (23 09 23.13.A.) SystemVu™ intelligent integrated Direct Digital Control (DDC) shall provide:
 - 1. Integrated unit operation for comfort cooling, heating ventilation as well as all monitoring, recording and reporting capabilities. Controller shall also provide diagnostics and alarms of abnormal unit operation through the controller. Controller shall have an intuitive user display and be able to be used in a standalone operation or via building automation system (BAS).
 - 2. Quick Unit Status LEDs of: Run — meaning all systems are go, ALERT — that indicates there is currently a non-critical issue with the unit, like filters need to be replaced and FAULT — that indicates the unit has a critical issue and will possibly shut down.
 - 3. Six large navigation keys for easy access. Navigation keys shall consist of: TEST, BACK, ENTER, and MENU along with UP and DOWN arrows.
 - 4. Full back lit user display with 4 line by 30 character text capabilities. Display menu shall be designed to provide guided major menus and sub menus main menus provided below:
 - a. Shutdown Unit
 - b. Run Status
 - c. Settings
 - d. Alerts/Faults
 - e. Service
 - f. Inputs
 - g. Outputs
 - h. USB
 - 5. The capability for standalone operation with conventional thermostat/sensor or use with building automation systems (BAS) of Carrier i-Vu®, BACnet™1, and Carrier Comfort Network® (CCN) systems. No special modules or boards are required for these capabilities. Has the capability to work with Equipment Touch™ and System Touch™ devices and ZS Sensors.
 - 6. The ability to read refrigerant pressures at display or via BAS network of; Discharge Pressure and Suction Pressure. The need for traditional refrigerant gauges is not required.
 - 7. USB Data Port for flash drive interaction. This will allow the transfer of data for uploads, downloads, perform software upgrades, backup and restore data and file transfer data such as component number of starts and run hours.

1. Third-party trademarks and logos are the property of their respective owners.

8. Reverse Rotation Protection of compressors if field 3-phase wiring is misapplied.
9. Provide Service Capabilities of:
 - a. Auto run test
 - b. Manual run test
 - c. Component run hours and starts
 - d. Commissioning reports
 - e. Data logging
 - f. Alarm history
10. Economizer control and diagnostics. Set up economizer operation, receive feedback from actuator. Also meets the most recent California Title 24, ASHRAE 90.1 and IECC¹ Fault Detection and Diagnostic (FDD) requirements.
11. Unit cooling operation down to 40°F (4°C).
12. Controller shall have easy access connections around the controller perimeter area and consist of Mate-N-Lok^{®1}, terminal block and RJ style modular jack connections.
13. 365 day real time clock, 20 holiday schedules along with occupied and unoccupied scheduling.
14. Auto-recognition for easy installation and commissioning of devices like economizers, space sensors, etc.
15. A 5°F (3°C) temperature difference between cooling and heating setpoints to meet the latest ASHRAE 90.1 Energy Standard.
16. Contain return air sensor, supply air sensor and outdoor air sensor to help monitor and provide data for the unit comfort operation, diagnostic and alarms.
17. Use of Carrier's field accessory Equipment Touch and System Touch devices.
18. Units with the factory-installed Humidi-MiZer[®] system option are capable of providing multiple modes of improved dehumidification as a variation of the normal cooling cycle.
19. Supply Air Tempering control operates the gas or electric heat to maintain a minimum supply air temperature during conditions where very cold outdoor air causes the supply air temperature to fall below the configured Supply Air Tempering Setpoint. This occurs during periods where DCV is active and increasing the amount of outdoor air or in cases where the system is operating at very low airflow and the calculated economizer position has increased to maintain a constant ventilation rate.
20. Demand limiting in SystemVu[™] is achieved through setpoint expansion. The systems heating and cooling setpoints are expanded in steps or levels. The degree to which the setpoints may be expanded is defined by the 6 demand

level offsets and the 2 commanded demand limit levels.

21. 3-year limited part warranty.

Part 5 — (23 09 33) Electric and Electronic Control System for HVAC

5.01 (23 09 33.13) Decentralized, Rooftop Units:

A. (23 09 33.13.A.) General:

1. Shall be complete with self-contained low-voltage control circuit protected by a resettable circuit breaker on the 24-v transformer side. Transformer shall have 75 VA capability.
2. Shall utilize color-coded wiring.
3. Shall include a Unit Control Board to conveniently and safely provide connection points for vital control functions such as: smoke detectors, phase monitor, economizer, thermostat, DDC control options, and low and high pressure switches. Controller shall also provide an intuitive means to adjust the indoor fan speed through a simple switch and pot adjustment design.
4. Unit shall include a minimum of one 8-pin screw terminal connection board for connection of control wiring.

B. (23 09 33.13.B.) Safeties:

1. Compressor over-temperature, over-current. High internal pressure differential.
2. Low Pressure Switch:
Low pressure switch shall use different color wire than the high pressure switch. The purpose is to assist the installer and service technician to correctly wire and or troubleshoot the rooftop unit.
3. High Pressure Switch:
High pressure switch shall use different color wire than the low pressure switch. The purpose is to assist the installer and service technician to correctly wire and or troubleshoot the rooftop unit.
4. Heating section shall be provided with the following minimum protections:
 - a. High temperature limit switches.
5. A2L Refrigerant Leak Dissipation System (Electromechanical):
 - a. Leak dissipation system shall consist of control board and A2L sensor certified to UL 60335-2-40.
 - b. System shall be designed for the life of the unit.
 - c. Dissipation system shall be automatic, ship pre-wired, and require no additional field connections to thermostat to function.
 - d. Refrigerant leak sensor shall be installed in UL-certified location and orientation. Sensor shall be self-correcting and resettable. Single

1. Third-party trademarks and logos are the property of their respective owners.

- use refrigerant leak sensor shall not be permitted.
- e. Factory-installed dissipation controller shall use onboard microprocessor and include:
 - 1) Automatic reset after a dissipation event has occurred.
 - 2) Onboard LED with flash code to indicate current unit status and hardware failures.
 - 3) Depressible “Test” button to allow for a system test and recall/reset of leak detection history.
 - 4) 24-v dry contact alarm terminal to allow for external notification of leak detection.
- f. Dissipation control board shall be accessible via normal maintenance locations and LED shall be visible.
- g. Dissipation system shall “Fail Safe” per UL requirements.
- h. Dissipation shall allow smoke and building fire systems to override in case of event.
- 6. A2L Refrigerant Leak Dissipation System (SystemVu):
 - a. Leak dissipation system shall consist of control board and A2L sensor certified to UL 60335-2-40, integrated with SystemVu controller.
 - b. System shall be designed for the life of the unit.
 - c. Dissipation system shall be automatic, ship pre-wired, and require no additional field connections to function.
 - d. Refrigerant leak sensor shall be installed in UL-certified location and orientation. Sensor shall be self-correcting and resettable. Single use refrigerant leak sensor shall not be permitted.
 - e. Factory-installed dissipation system shall use onboard microprocessor and include:
 - 1) Automatic leak detection and dissipation algorithm.
 - 2) Automatic reset after a dissipation event has occurred.
 - 3) Onboard LED with flash code to indicate current unit status and hardware failures.
 - 4) Depressible “Test” button to allow for a system test and recall/reset of leak detection history.
 - 5) 24-v dry contact alarm terminal on dissipation control board to allow for external notification of leak detection.
 - 6) Ability to notify BAS system of dissipation event via readable alarm point through SystemVu.
 - 7) Recallable dissipation alarm history on SystemVu controller.

- f. Dissipation control board shall be accessible via normal maintenance locations and LED shall be visible.
- g. Dissipation system shall “Fail Safe” per UL requirements.
- h. Dissipation shall allow smoke and building fire systems to override in case of event.

Part 6 — (23 09 93) Sequence of Operations for HVAC Controls

- 6.01 (23 09 93.13) Decentralized, Rooftop Units:
 - A. (23 09 93.13.A.) INSERT SEQUENCE OF OPERATION

Part 7 — (23 40 13) Panel Air Filters

- 7.01 (23 40 13.13) Decentralized, Rooftop Units:
 - A. (23 40 13.13.A.) Standard Filter Section:
 1. Shall consist of factory installed, low velocity, disposable 2 in. thick fiberglass filters of commercially available sizes.
 2. Unit shall use only one filter size. Multiple sizes are not acceptable.
 3. Filters shall be accessible through an access panel with “no-tool” removal as described in the unit cabinet section of this specification (23 81 19.13.G).

Part 8 — (23 81 19) Self-Contained Air Conditioners

- 8.01 (23 81 19.13) Small-Capacity Self-Contained Air Conditioners:
 - A. (23 81 19.13.A.) General:
 1. Outdoor, rooftop-mounted, electrically controlled cooling unit, utilizing a fully hermetic scroll compressor(s) for cooling duty.
 2. Factory assembled, single-piece cooling rooftop unit. Contained within the unit enclosure shall be all factory wiring, piping, controls, and special features required prior to field start-up.
 3. Unit shall use Puron Advance™ (R-454B) refrigerant.
 4. Unit shall be installed in accordance with the manufacturer’s instructions.
 5. Unit must be selected and installed in compliance with local, state, and federal codes.
 - B. (23 81 19.13.B.) Quality Assurance:
 1. Unit meets DOE and ASHRAE 90.1 minimum efficiency requirements.
 2. Unit shall be rated in accordance with AHRI Standards 210/240 (04-06 sizes) or 340/360 (07 size).
 3. Unit shall be designed to conform to ASHRAE 15.
 4. Unit shall be UL-tested and certified in accordance with ANSI Z21.47 Standards and UL-listed and certified under Canadian standards as a total package for safety requirements.

5. Insulation and adhesive shall meet NFPA 90A requirements for flame spread and smoke generation.
 6. Unit casing shall be capable of withstanding 500 hour salt spray exposure per ASTM B117 (scribed specimen).
 7. Unit shall be designed in accordance with ISO 9001, and shall be manufactured in a facility registered by ISO 9001:2015.
 8. Roof curb shall be designed to conform to NRCA Standards.
 9. Unit shall be subjected to a completely automated run test on the assembly line. The data for each unit will be stored at the factory, and must be available upon request.
 10. Unit shall be designed in accordance with UL Standards 60335-1 and 60335-2-40, including testing to withstand rain. Unit shall be IPX4 rated.
 11. Unit shall be constructed to prevent intrusion of snow and tested to prevent snow intrusion into the control box up to 40 mph.
 12. Unit shake tested to assurance level 1, ASTM D4169 to ensure shipping reliability.
- C. (23 81 19.13.C.) Delivery, Storage, and Handling:
1. Unit shall be stored and handled per manufacturer's recommendations.
 2. Lifted by crane requires either shipping top panel or spreader bars.
 3. Unit shall only be stored or positioned in the upright position.
- D. (23 81 19.13.D.) Project Conditions:
1. As specified in the contract.
- E. (23 81 19.13.E.) Operating Characteristics:
1. Unit shall be capable of starting and running at 115°F (46°C) ambient outdoor temperature, meeting maximum load criteria of AHRI Standard 210/240 or 340/360 at ±10% voltage.
 2. Compressor with standard controls shall be capable of operation down to 40°F (4°C) ambient outdoor temperatures.
 3. Unit shall discharge supply air vertically or horizontally as shown on contract drawings.
 4. Unit shall be factory configured for vertical supply and return configurations.
 5. Unit shall be field convertible from vertical to horizontal airflow on all models. No special kit required.
 6. Unit shall be capable of mixed operation: vertical supply with horizontal return or horizontal supply with vertical return.
- F. (23 81 19.13.F.) Electrical Requirements:
1. Main power supply voltage, phase, and frequency must match those required by the manufacturer.
- G. (23 81 19.13.G.) Unit Cabinet:
1. Unit cabinet shall be constructed of galvanized steel, and shall be bonderized and coated with a prepainted baked enamel finish on all externally exposed surfaces.
 2. Unit cabinet exterior paint shall be: film thickness, (dry) 0.003 in. minimum, gloss (per ASTM D523, 60°F/16°C): 60, Hardness: H-2H Pencil hardness.
 3. Evaporator fan compartment interior cabinet insulation shall conform to AHRI Standards 210/240 and or 340/360 minimum exterior sweat criteria. Interior surfaces shall be insulated with a minimum 1/2 in. thick, 1 lb density, flexible fiberglass insulation, neoprene coated on the air side. Aluminum foil-faced fiberglass insulation shall be used in the heat compartment.
 4. Base of unit shall have a minimum of 4 locations for thru-the-base gas and electrical connections (factory-installed or field-installed), standard.
 5. Base Rail:
 - a. Unit shall have base rails on a minimum of 2 sides.
 - b. Holes shall be provided in the base rails for rigging shackles to facilitate maneuvering and overhead rigging.
 - c. Holes shall be provided in the base rail for moving the rooftop by fork truck.
 - d. Base rail shall be a minimum of 16 gauge thickness.
 6. Condensate Pan and Connections:
 - a. Shall be a sloped condensate drain pan made of a corrosion resistant material.
 - b. Shall comply with ASHRAE Standard 62.
 - c. Shall use a 3/4 in. 14 NPT drain connection, possible either through the bottom or side of the drain pan. Connection shall be made per manufacturer's recommendations.
 7. Top Panel:

Shall be a single piece top panel on all sizes.
 8. Electrical Connections:
 - a. All unit power wiring shall enter unit cabinet at a single, factory prepared, knockout location.
 - b. Thru-the-base capability:
 - 1) Standard unit shall have a thru-the-base electrical location(s) using a raised, embossed portion of the unit basepan.
 - 2) Optional, factory approved, water-tight connection method must be used for thru-the-base electrical connections.
 - 3) No basepan penetration, other than those authorized by the manufacturer, is permitted.

9. Component Access Panels (standard):
 - a. Cabinet panels shall be easily removable for servicing.
 - b. Unit shall have one factory installed, tool-less, removable, filter access panel.
 - c. Panels covering control box, indoor fan, indoor fan motor, gas components (where applicable), and compressors shall have molded composite handles.
 - d. Handles shall be UV modified, composite. They shall be permanently attached, and recessed into the panel.
 - e. Screws on the vertical portion of all removable access panel shall engage into heat resistant, molded composite collars.
 - f. Collars shall be removable and easily replaceable using manufacturer recommended parts.
- H. (23 81 19.13.H.) Coils:
 1. Standard Aluminum Fin-Copper Tube Coils:
 - a. Standard evaporator and condenser coils shall have aluminum lanced plate fins mechanically bonded to seamless internal helically grooved copper tubes with all joints brazed.
 - b. Evaporator coils shall be leak tested to 150 psig, pressure tested to 450 psig, and qualified to UL 60335-2-40 burst test at 1775 psig.
 - c. Condenser coils shall be leak tested to 150 psig, pressure tested to 650 psig, and qualified to UL 60335-2-40 burst test at 1980 psig.
 2. Optional Pre-coated Aluminum-Fin Condenser Coils (3-Phase Models Only):
 - a. Shall have a durable epoxy-phenolic coating to provide protection in mildly corrosive coastal environments.
 - b. Coating shall be applied to the aluminum fin stock prior to the fin stamping process to create an inert barrier between the aluminum fin and copper tube.
 - c. Epoxy-phenolic barrier shall minimize galvanic action between dissimilar metals.
 - d. Corrosion durability of fin stock shall be confirmed through testing to be no less than 1000 hours salt spray per ASTM B117.
 - e. Corrosion durability of fin stock shall be confirmed through testing to have no visible corrosion after 48 hour immersion in a room temperature solution of 5% salt, 1% acetic acid.
 - f. Fin stock coating shall pass 2000 hours of the following: one week exposure in the progression chamber followed by one week of accelerated ultraviolet light testing. Progression chamber: the solution shall contain 3.5% sodium chloride and 0.35% ammonium sulfate. The exposure cycle is one hour of salt fog application at ambient followed by one hour drying at 95°F (35°C).
 3. Optional Copper-Fin Evaporator and Condenser Coils (3-Phase Models Only):
 - a. Shall be constructed of copper fins mechanically bonded to copper tubes and copper tube sheets.
 - b. Galvanized steel tube sheets shall not be acceptable.
 - c. A polymer strip shall prevent coil assembly from contacting the sheet metal coil pan to minimize potential for galvanic corrosion between coil and pan.
 4. Optional E-coated Aluminum-Fin Evaporator and Condenser Coils (3-Phase Models Only):
 - a. Shall have a flexible epoxy polymer coating uniformly applied to all coil surface areas without material bridging between fins.
 - b. Coating process shall ensure complete coil encapsulation of tubes, fins and headers.
 - c. Color shall be high gloss black with gloss per ASTM D523.
 - d. Uniform dry film thickness from 0.8 to 1.2 mil on all surface areas including fin edges.
 - e. Superior hardness characteristics of 2H per ASTM D3363 and cross-hatch adhesion of 4B-5B per ASTM D3359.
 - f. Impact resistance shall be up to 160 in.-lb (ASTM D2794).
 - g. Humidity and water immersion resistance shall be up to minimum 1000 and 250 hours respectively (ASTM D2247 and ASTM D870).
 - h. Corrosion durability shall be confirmed through testing to be no less than 1000 hours salt spray per ASTM B117.
- I. (23 81 19.13.I.) Refrigerant Components:
 1. Refrigerant circuit shall include the following control, safety, and maintenance features:
 - a. Fixed orifice metering system on 04-06 models and TXV on 07 size models shall include a multiple feed distribution system that optimizes coil performance.
 - b. Refrigerant filter drier, solid core design with pre and post-filter service gauge connections for filter diagnostics and maintenance.
 - c. Service gauge connections on suction and discharge lines.
 - d. Pressure gauge access through a specially designed access port in the top panel of the unit.

2. There shall be gauge line access port in the skin of the rooftop, covered by a black, removable plug.
 - a. The plug shall be easy to remove and replace.
 - b. When the plug is removed, the gauge access port shall enable maintenance personnel to route their pressure gauge lines.
 - c. This gauge access port shall facilitate correct and accurate condenser pressure readings by enabling the reading with the compressor access panel on.
 - d. The plug shall be made of a leak proof, UV-resistant, composite material.
3. Compressors:
 - a. Unit shall use fully hermetic scroll compressors.
 - b. Compressor motors shall be cooled by refrigerant gas passing through motor windings.
 - c. Compressors shall be internally protected from high discharge temperature conditions.
 - d. Compressors shall be protected from an over-temperature and over-amperage conditions by an internal, motor overload device.
 - e. Compressor shall be factory mounted on rubber grommets.
 - f. Compressor motors shall have internal line break thermal, current overload and high pressure differential protection.
 - g. Crankcase heaters shall not be required for normal operating range, unless required by compressor manufacturer due to refrigerant charge limits.
 - h. Compressor on 04-06 models shall be of a single stage cooling capacity design and 07 models shall be a 2 stage cooling capacity design.
- J. (23 81 19.13.J.) Filter Section:
 1. Filters access is specified in the unit cabinet section of this specification.
 2. Filters shall be held in place by a pivoting filter tray, facilitating easy removal and installation.
 3. Shall consist of factory installed, low velocity, throw-away 2 in. thick fiberglass filters.
 4. Filters shall be standard, commercially available sizes.
 5. Only one size filter per unit is allowed.
- K. (23 81 19.13.K.) Evaporator Fan and Motor with EcoBlue™ Technology:
 1. Direct Drive Evaporator Fan Motor:
 - a. Shall be an ECM motor design.
 - b. Shall be direct drive design for all static options.
 - c. Shall have permanently lubricated bearings.
 - d. Shall have inherent automatic-reset thermal overload protection.
 - e. Shall have slow ramp-up to speed capabilities.
 - f. Shall require no fan/motor belts for operation, adjustments and or initial fan speed set up.
 - g. Fan DC voltage set up on Unit Control Board can eliminate the need of removal of blower access door, required on conventional belt drive systems.
 - h. Shall be internally protected from electrical phase reversal.
 2. Evaporator Fan:
 - a. Speed shall be easily set with dedicated selection switch and adjustment pot on unit control board or through SystemVu™ controller.
 - b. On sizes 04-06 single speed indoor fan operation provided and on 07 size model with 2 stage cooling capacity control, the indoor fan speed is automatically controlled to meet the code-compliant 66% low fan speed and 100% at full fan speed operation.
 - c. Blower fan shall be a vane axial fan design with fan assembly secured directly to ECM motor. Additional shafts, belts, pulleys/sheaves, and bearing blocks to drive fan shall not be permitted or necessary.
 - d. Additional variable frequency drive to control fan motor speed shall not be permitted or necessary. All speed control electronics must be on board fan motor assembly.
 - e. Shall be constructed of an aluminum stator or high impact composite material on stator, rotor and air inlet casing.
 - f. Shall be a patented / pending design with a corrosion resistant material.
 - g. Fan assembly design shall be integrated into fan deck, dynamically balanced, and require no additional vibration isolation for normal operation.
 - h. Shall have slow ramp-up to speed capabilities to help reduce sound and comfort issues typically associated with single speed belt drive systems.
 - i. Shall be a slide out design with 2 screw removal.
 3. Shall include an easily accessible Unit Control Board to conveniently and safely provide connection points for vital control functions such as: smoke detectors, phase monitor, economizer, thermostat, DDC control options, and low and high pressure switches. Controller shall also provide an intuitive means to adjust the indoor fan speed through a simple switch and pot adjustment design.

L. (23 81 19.13.L.) Condenser Fans and Motors:

1. Condenser Fan Motors:
 - a. Shall be a totally enclosed motor.
 - b. Shall use permanently lubricated bearings.
 - c. Shall have inherent thermal overload protection with an automatic reset feature.
 - d. Shall use a shaft-down design on all sizes.
2. Condenser Fans:

- a. Shall be a direct-driven propeller type fan constructed of high impact composite material.
- b. Shall have high impact composite blades completely formed into one piece without blade fasteners or connectors and shall be dynamically balanced.

M. (23 81 19.13.M.) Special Features Options and Accessories:

1. Integrated EconomizerONE and EconoMi\$er2 Low Leak Rate Models.
 - a. Integrated, gear driven opposing modulating blade design type capable of simultaneous economizer and compressor operation.
 - b. Independent modules for vertical or horizontal return configuration shall be available. Vertical return modules shall be available as a factory-installed option.
 - c. Damper blades shall be galvanized steel with composite gears. Plastic or composite blades on intake or return shall not be acceptable.
 - d. Shall include all hardware and controls to provide free cooling with outdoor air when temperature and/or humidity are below setpoints.
 - e. Shall be equipped with gear driven dampers for both the outdoor ventilation air and the return air for positive air stream control.
 - f. Low leak rate shall be equipped with dampers not to exceed 2% leakage at 1 in. wg pressure differential.
 - g. Economizer controller on EconomizerONE models shall be the Siemens POL224 that provides:
 - 1) Combined minimum and DCV maximum damper position potentiometers with compressor staging relay.
 - 2) Optional configuration via WLAN stick and Siemens Climatix™1 smartphone app for easy setup.
 - 3) Functions with solid-state analog enthalpy or dry bulb changeover control sensing.
 - 4) LED indication for free cooling, sensor, and damper operation.

- 5) One-line LCD interface screen for setup, configuration, and troubleshooting.
- 6) On-board Fault Detection and Diagnostics (FDD) that senses and alerts when the economizer is not operating properly, per California Title 24, ASHRAE 90.1 and IECC.
- 7) Sensor failure loss of communication identification.
- 8) Capabilities for use with multiple-speed or single speed indoor fan systems.
- 9) Digital sensors: dry bulb and enthalpy.
- h. Economizer controller on EconoMi\$er 2 models with SystemVu™ controllers shall be a 4 to 20 mA design controlled directly by the controller. SystemVu controllers meet California Title 24, ASHRAE 90.1 and IECC Fault Detection and Diagnostic (FDD) requirements.
 - i. Shall be capable of introducing up to 100% outdoor air.
 - j. Shall be equipped with a barometric relief damper capable of relieving up to 100% return air and contain seals that meet ASHRAE 90.1 requirements.
 - k. Shall be designed to close damper(s) during loss-of-power situations with spring return built into motor.
 - l. Dry bulb outdoor air temperature sensor shall be provided as standard. Enthalpy sensor is also available on factory installed only. Outdoor air sensor setpoint shall be adjustable and shall range from 40°F to 100°F (4°C to 38°C). Additional sensor options shall be available as accessories.
 - m. The economizer controller shall also provide control of an accessory power exhaust unit function. Factory set at 100%, with a range of 0% to 100%.
 - n. The economizer shall maintain minimum airflow into the building during occupied period and provide design ventilation rate for full occupancy.
 - o. Dampers shall be completely closed when the unit is in the unoccupied mode.
 - p. Economizer controller shall accept a 0 to 10 vdc CO₂ sensor input for IAQ/DCV control. In this mode, dampers shall modulate the outdoor air damper to provide ventilation based on the sensor input.
 - q. Compressor lockout temperature on POL224 control is adjustable from -45°F to 80°F (-43°C to 26°C), set at a factory default of 32°F (0°C).
 - r. Actuator shall be direct coupled to economizer gear. No linkage arms or control rods shall be acceptable.

1. Third-party trademarks and logos are the property of their respective owners.

- s. Contains LED indication for free cooling, sensor, and damper operation.
- 2. Integrated EconomizerONE and EconoMi\$er® 2 Ultra Low Leak Rate Models.
 - a. Integrated, gear driven opposing modulating blade design type capable of simultaneous economizer and compressor operation.
 - b. Independent modules for vertical or horizontal return configuration shall be available. Vertical return modules shall be available as a factory-installed option.
 - c. Damper blades shall be galvanized steel with composite gears. Plastic or composite blades on intake or return shall not be acceptable.
 - d. Shall include all hardware and controls to provide free cooling with outdoor air when temperature and/or humidity are below setpoints.
 - e. Shall be equipped with gear driven dampers for both the outdoor ventilation air and the return air for positive air stream control.
 - f. Ultra Low Leak design meets California Title 24 section 140.4 and ASHRAE 90.1 requirements for 4 cfm per sq ft on the outside air dampers and 10 cfm per sq ft on the return dampers.
 - g. Economizer controller on EconomizerONE models shall be the Siemens POL224 that provides:
 - 1) One-line LCD interface screen for setup, configuration, and troubleshooting.
 - 2) Optional configuration via WLAN stick and Siemens Climatix™ smartphone app for easy setup.
 - 3) On-board Fault Detection and Diagnostics (FDD) that senses and alerts when the economizer is not operating properly, per California Title 24, ASHRAE 90.1 and IECC.
 - 4) Sensor failure loss of communication identification.
 - 5) Capabilities for use with multiple-speed indoor fan systems.
 - 6) Digital sensors: dry bulb and enthalpy.
 - h. Economizer controller on EconoMi\$er 2 models with SystemVu™ controls shall be a 4 to 20 mA design controlled directly by the controller. SystemVu controllers meet California Title 24, ASHRAE 90.1 and IECC Fault Detection and Diagnostic (FDD) requirements.
 - i. Shall be capable of introducing up to 100% outdoor air.
 - j. Shall be equipped with a barometric relief damper capable of relieving up to 100% return air and contain seals that meet ASHRAE 90.1 requirements.
 - k. Shall be designed to close damper(s) during loss-of-power situations with spring return built into motor.
 - l. Dry bulb outdoor air temperature sensor shall be provided as standard. Enthalpy sensor is also available factory-installed only. Outdoor air sensor setpoint shall be adjustable and shall range from 40°F to 100°F (4°C to 38°C). Additional sensor options shall be available as accessories.
 - m. The economizer controller shall also provide control of an accessory power exhaust unit function. Factory set at 100%, with a range of 0% to 100%.
 - n. The economizer shall maintain minimum airflow into the building during occupied period and provide design ventilation rate for full occupancy.
 - o. Dampers shall be completely closed when the unit is in the unoccupied mode.
 - p. Economizer controller shall accept a 0 to 10 vdc CO₂ sensor input for IAQ/DCV control. In this mode, dampers shall modulate the outdoor air damper to provide ventilation based on the sensor input.
 - q. Compressor lockout temperature on POL224 control is adjustable from -45°F to 80°F (-43°C to 26°C), set at a factory default of 32°F (0°C).
 - r. Actuator shall be direct coupled to economizer gear. No linkage arms or control rods shall be acceptable.
 - s. Contains LED indication for free cooling, sensor, and damper operation.
- 3. Wi-Fi/WLAN Stick for EconomizerONE POL224 (field installed):

This item allow for the use of the Siemens Climatix™ mobile application.
- 4. Two-Position Damper (Field-installed only)
 - a. Damper shall be a Two-Position Damper. Damper travel shall be from the full closed position to the field adjustable %-open setpoint.
 - b. Damper shall include adjustable damper travel from 25% to 100% (full open).
 - c. Damper shall include single or dual blade, gear driven dampers and actuator motor.
 - d. Actuator shall be direct coupled to damper gear. No linkage arms or control rods shall be acceptable.
 - e. Damper will admit up to 100% outdoor air for applicable rooftop units.
 - f. Damper shall close upon indoor (evaporator) fan shutoff and/or loss of power.
 - g. The damper actuator shall plug into the rooftop unit's wiring harness plug. No hard wiring shall be required.

- h. Outside air hood shall include aluminum water entrainment filter.
- 5. Manual Damper (field-installed only):
Manual damper package shall consist of damper, air inlet screen, and rain hood which can be preset to admit up to 25% or 50% outdoor air for year round ventilation.
- 6. Humidi-MiZer Adaptive Dehumidification System (3-Phase Models Only):
The Humidi-MiZer Adaptive Dehumidification System shall be factory installed and shall provide greater dehumidification of the occupied space by 2 modes of dehumidification operations in addition to its normal design cooling mode:
 - a. Subcooling mode further sub cools the hot liquid refrigerant leaving the condenser coil when both temperature and humidity in the space are not satisfied.
 - b. Hot gas reheat mode shall mix a portion of the hot gas from the discharge of the compressor with the hot liquid refrigerant leaving the condenser coil to create a 2-phase heat transfer in the system, resulting in a neutral leaving air temperature when only humidity in the space is not satisfied.
 - c. Includes low ambient controller.
- 7. Low Ambient Control Package:
 - a. Controller shall control coil head pressure by condenser fan speed modulation or condenser fan cycling and wind baffles.
 - b. Shall consist of solid-state control and condenser coil temperature sensor to maintain condensing temperature between 90°F (32°C) and 110°F (43°C) at outdoor ambient temperatures down to -20°F (-29°C). For full low ambient control range, winter start kit is required.
- 8. Condenser Coil Hail Guard Assembly (Factory-installed on 3-Phase Models Only. Field-installed on all 3 and 1-Phase Models.)
 - a. Shall protect against damage from hail.
 - b. Shall be either hood style or louvered.
- 9. Unit-Mounted, Non-Fused Disconnect Switch (Available on units with MOCPs of 80 amps or less):
 - a. Switch shall be factory installed, internally mounted.
 - b. National Electric Code (NEC) and UL approved non-fused switch shall provide unit power shutoff.
 - c. Shall be accessible from outside the unit.
 - d. Shall provide local shutdown and lockout capability.
- e. Sized only for the unit as ordered from the factory. Does not accommodate field-installed devices.
- 10. Convenience Outlet:
 - a. Factory-Installed Powered Convenience Outlet (3-Phase Models Only):
 - 1) Outlet shall be powered from main line power to the rooftop unit.
 - 2) Outlet shall be powered from line side or load side of disconnect by installing contractor, as required by code. If outlet is powered from load side of disconnect, unit electrical ratings shall be UL certified and rated for additional outlet amperage.
 - 3) Outlet shall be factory-installed and internally mounted with easily accessible 115-v female receptacle.
 - 4) Outlet shall include 15 amp GFI receptacles with independent fuse protection.
 - 5) Voltage required to operate convenience outlet shall be provided by a factory installed step-down transformer.
 - 6) Outlet shall be accessible from outside the unit.
 - 7) Outlet shall include a field installed “Wet in Use” cover.
 - b. Factory-Installed Non-Powered Convenience Outlet:
 - 1) Outlet shall be powered from a separate 115/120v power source.
 - 2) A transformer shall not be included.
 - 3) Outlet shall be factory-installed and internally mounted with easily accessible 115-v female receptacle.
 - 4) Outlet shall include 15 amp GFI receptacles with independent fuse protection.
 - 5) Outlet shall be accessible from outside the unit.
 - 6) Outlet shall include a field installed “Wet in Use” cover.
 - c. Field-Installed Non-Powered Convenience Outlet:
 - 1) Outlet shall be powered from a separate 115/120-v power source.
 - 2) A transformer shall not be included.
 - 3) Outlet shall be field-installed and internally mounted with easily accessible 115-v female receptacle.
 - 4) Outlet shall include 20 amp GFI receptacles. This kit provides a flexible installation method which allows code compliance for height requirements of the GFCI outlet from the finished roof surface as well as the capability to

- relocate the outlet to a more convenient location.
 - 5) Outlet shall be accessible from outside the unit.
 - 6) Outlet shall include a field installed “Wet in Use” cover.
11. Thru-the-Base Connectors:
- a. Kits shall provide connectors to permit gas and electrical connections to be brought to the unit through the unit basepan.
 - b. Minimum of 4 connection locations per unit.
12. Propeller Power Exhaust:
- a. Power exhaust shall be used in conjunction with an integrated economizer.
 - b. Independent modules for vertical or horizontal return configurations shall be available.
 - c. Horizontal power exhaust shall be mounted in return ductwork.
 - d. Power exhaust shall be controlled by economizer controller operation. Exhaust fans shall be energized when dampers open past the 0 to 100% adjustable setpoint on the economizer control.
13. Roof Curbs (Vertical):
- a. Full perimeter roof curb with exhaust capability providing separate air streams for energy recovery from the exhaust air without supply air contamination.
 - b. Formed galvanized steel with wood nailer strip and shall be capable of supporting entire unit weight.
 - c. Permits installation and securing of ductwork to curb prior to mounting unit on the curb.
14. Outdoor Air Enthalpy Sensor:
- The outdoor air enthalpy sensor shall be used to provide single enthalpy control. When used in conjunction with a return air enthalpy sensor, the unit will provide differential enthalpy control. The sensor allows the unit to determine if outside air is suitable for free cooling.
15. Return Air Enthalpy Sensor:
- The return air enthalpy sensor shall be used in conjunction with an outdoor air enthalpy sensor to provide differential enthalpy control.
16. Indoor Air Quality (CO₂) Sensor:
- a. Shall be able to provide demand ventilation indoor air quality (IAQ) control.
 - b. The IAQ sensor shall be available in duct mount, wall mount, or wall mount with LED display. The setpoint shall have adjustment capability.
17. Smoke Detectors:
- a. Shall be a 4-wire controller and detector.
 - b. Shall be environmentally compensated with differential sensing for reliable, stable, and drift-free sensitivity.
 - c. Shall use magnet-activated test/reset sensor switches.
 - d. Shall have tool-less connection terminal access.
 - e. Shall have a recessed momentary switch for testing and resetting the detector.
 - f. Controller shall include:
 - 1) One set of normally open alarm initiation contacts for connection to an initiating device circuit on a fire alarm control panel.
 - 2) Two Form-C auxiliary alarm relays for interface with rooftop unit or other equipment.
 - 3) One Form-C supervision (trouble) relay to control the operation of the Trouble LED on a remote test/reset station.
 - 4) Capable of direct connection to 2 individual detector modules.
 - 5) Can be wired to up to 14 other duct smoke detectors for multiple fan shut-down applications.
18. Winter Start Kit:
- a. Shall contain a bypass device around the low pressure switch.
 - b. Shall be required when mechanical cooling is required below 40°F (4°C).
 - c. Shall not be required to operate on an economizer for cooling when below an outdoor ambient of 40°F (4°C).
19. Time Guard:
- a. Shall prevent compressor short-cycling by providing a 5-minute delay (± 2 minutes) before restarting a compressor after shut-down for any reason.
 - b. One device shall be required per compressor.
20. Hinged Access Panels:
- a. Shall provide easy access through integrated quarter turn latches.
 - b. Shall be on major panels of: filter, control box, fan motor, and compressor.
21. Condensate Overflow Switch:
- This sensor and related controller monitors the condensate level in the drain pan and shuts down compression operation when overflow conditions occur. It includes:
- a. Indicator light — solid red (more than 10 seconds on water contact — compressors disabled), blinking red (sensor disconnected).

Guide specifications — 50FE (cont)

- b. 10 second delay to break — eliminates nuisance trips from splashing or waves in pan (sensor needs 10 seconds of constant water contact before tripping).
 - c. Disables the compressor(s) operation when condensate plug is detected, but still allows fans to run for economizer.
22. 4 in. MERV-13 Return Air Filters (factory-installed only):
- a. Factory option to upgrade standard unit filters to 4 in. MERV-13 filters.
 - b. Upgraded option shall include factory-installed 4 in. filter rack.
 - c. Shall not be compatible with horizontal units with field-installed economizers.
 - d. Shall not be compatible with size 04-06 units with Humidi-MiZer or any single phase units.
23. 4 in. Return Air Rack (field-installed only):
- a. Accessory kit is designed to hold 4 in. MERV-8 or MERV-13 filters. Filters not included in kit.
 - b. Shall not be compatible with horizontal units with field installed economizers.
 - c. Shall not be compatible with size 04-06 units with Humidi-MiZer.
24. 2 in. MERV-13 Return Air Filters:
- a. Accessory kit to field upgrade standard unit filters to 2 in. MERV-13 filters.
 - b. Correct size and quantity of filters shall ship in a single box
25. 2 in. MERV-8 Return Air Filters:
- a. Accessory kit to field upgrade standard unit filters to 2 in. MERV-8 filters.
 - b. Correct size and quantity of filters shall ship in a single box.
26. Phase Monitor Control:
- a. Shall monitor the sequence of 3-phase electrical system to provide a phase reversal protection.
 - b. Shall monitor the 3-phase voltage inputs to provide a phase loss protection for the 3-phase device.
- c. Will work on either a Delta or Wye power connection.
27. Horn/Strobe Annunciator:
- Provides an audible/visible signaling device for use with factory-installed option or field installed accessory smoke detectors.
- a. Requires installation of a field-supplied 24-v transformer suitable for 4.2 VA (AC) or 3.0 VA (DC) per horn/strobe accessory.
 - b. Requires field-supplied electrical box, North American 1-gang box, 2 in. (51 mm) x 4 in. (102 mm).
 - c. Shall have a clear colored lens.
28. Electric Heat:
- a. Heating Section:
 - 1) Heater element open coil resistance wire, nickel-chrome alloy, 0.29 in. inside diameter, strung through ceramic insulators mounted on metal frame. Coil ends are staked and welded to terminal screw slots.
 - 2) Heater assemblies are provided with integral fusing for protection of internal heater circuits. Auto-reset thermo limit controls, magnetic heater contactors (24-v coil), and terminal block all mounted in electric heater control box (minimum 18 ga galvanized steel) attached to end of heater assembly.
29. High Short Circuit Current Rating (SCCR) Protection:
- a. Factory-installed option shall provide high short circuit current protection to compressor and all indoor and outdoor fan motors rated at 10 kA against high potential fault current situations. (Standard unit comes with 5 kA rating.)
 - b. This option is not available with factory-installed Humidi-MiZer, powered convenience outlet, non-fused disconnect, low ambient controls, phase loss monitor/protection, or 575-v models.