

bryant

Day &
Night

PAYNE

installation instructions

BAROMETRIC RELIEF AIR DAMPER P/N 309273-226

542F/559F/579F

551A/581A

559E/579E

Sizes 150-300
12½ to 28 Tons

Cancels: New

IHK 542F-150-8
3/1/94

Barometric relief air damper P/N 309273-226 is used on Models 542F, 551A, 559E/F, 579E/F, and 581A (cooling sizes 150-300).

INSTALLATION

A. Package Contents

The relief air damper kit includes:

- 1 — Damper assembly (Fig. 1)
- 1 — Center post
- 1 — Insulated panel
- 7 — No. 10AB x ½-in. long screws

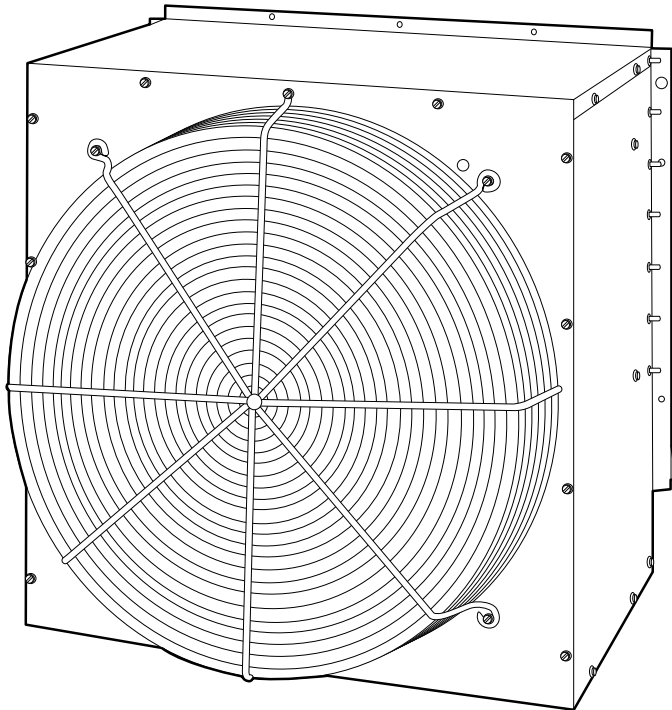

Fig. 1 — Accessory Relief Damper Assembly

B. Procedure

1. Remove alternate return-air access panel (Fig. 2) and save screws. Using these screws, install center post and insulated panel assembly as shown in Fig. 3.
2. Position damper assembly in return-air opening (Fig. 3). Use retainer on back of damper assembly to facilitate positioning (Fig. 4).
3. Using no. 10AB x ½-in. screws, fasten damper assembly to unit (Fig. 5).

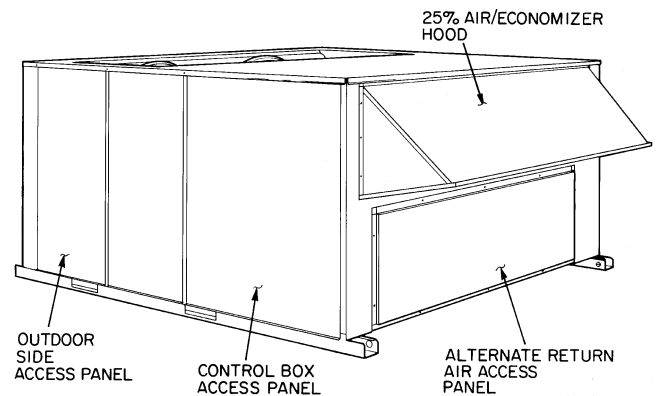

Fig. 2 — Typical Base Unit

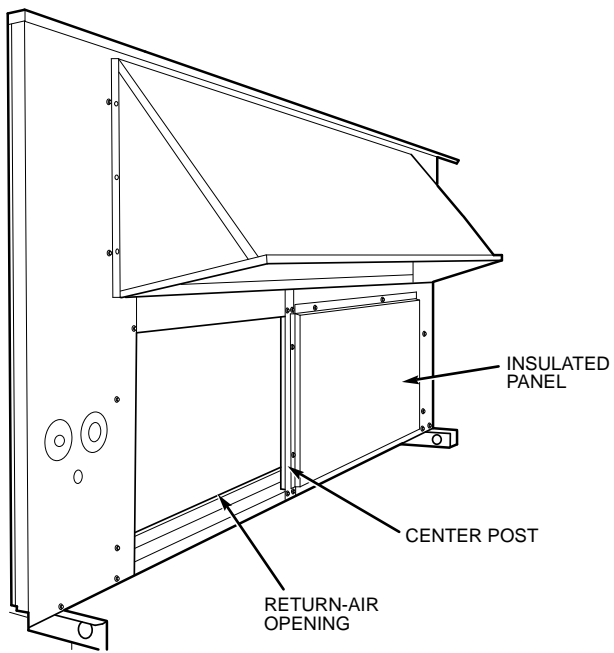

Fig. 3 — Base Unit Details

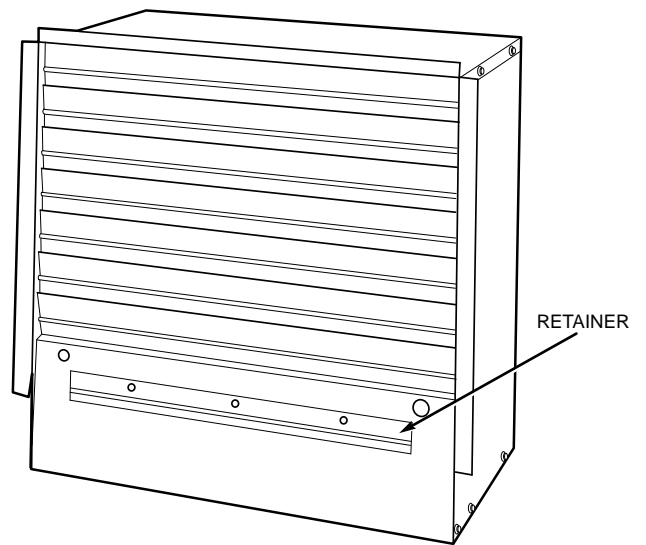

Fig. 4 — Relief Damper Assembly

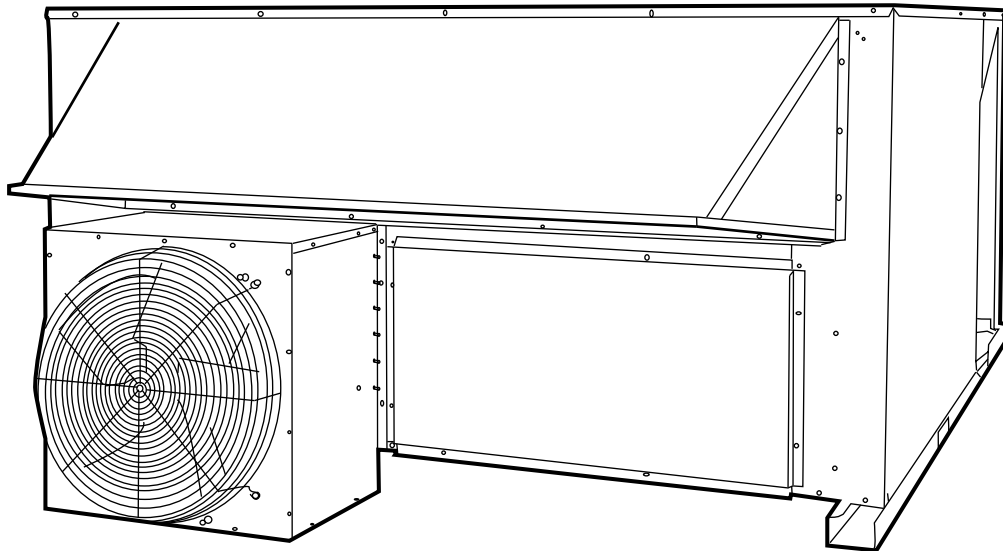

Fig. 5 — Base Unit with Relief Damper Assembly Installed