



WeatherMaker® 48K Gas Heating and Electric Cooling Applied Rooftop Units with Puron Advance™ Refrigerant (R-454B) and Carrier SmartVu™ Controls

User's Information and Maintenance Manual

CONTENTS

	Page
GENERAL	1
SAFETY CONSIDERATIONS	1
MAINTENANCE ACCESS	4
Access Doors	6
• ACCESS DOOR LATCH	
• ACCESS DOOR RETAINERS	
Control Box	6
Power Box	6
• UNITS WITH NON-FUSED DISCONNECT	
Electronic Expansion Valve (EXV) Access Panel ..	7
Access Panels	7
ROUTINE MAINTENANCE	8
Monthly Inspection	8
Cooling Season Start-Up	8
Heating Season Start-Up	8
MAINTENANCE INSTRUCTIONS	8
Indoor Coil Filters	8
• FILTER INSPECTION	
• FILTER REPLACEMENT	
• FILTER CHANGE REMINDER	
Outdoor Coils	11
• OUTDOOR COIL RINSING	
• OUTDOOR COIL CLEANING	
Indoor Coils	11
• INDOOR COIL RINSING	
• INDOOR COIL CLEANING	
• CLEANING COILS WITH AIR	
Indoor Fan System	12
• INSPECT BELTS	
• BELT REPLACEMENT	
• ADJUST BELT TENSION	
• INSPECT FAN AND MOTOR SHEAVES	
• SHEAVE ALIGNMENT	
• INSPECT FAN SHAFT BEARINGS	
• LUBRICATE FAN SHAFT BEARINGS AND COUPLER	
• LUBRICATE INDOOR FAN MOTOR	
• INSPECT INDOOR FAN MOTOR VARIABLE FREQUENCY DRIVE (VFD)	
Gas Heating System	15
• HEATING SYSTEM START-UP	
• HEATING SYSTEM SHUTDOWN	
Outdoor Intake and Relief	17
• OUTDOOR AIR SCREENS	
• ECONOMIZER DAMPER	
• BAROMETRIC RELIEF SYSTEM	
• POWER EXHAUST	
Electrical Connections	17
Refrigerant Circuit	17
• ELECTRONIC EXPANSION VALVES (EXVS)	

- COMPRESSORS
- OUTDOOR FANS
- INSPECT OUTDOOR FAN MOTOR VARIABLE FREQUENCY DRIVE (VFD)
- A2L Leak Dissipation System** 17
- SENSOR CALIBRATION
- LEAK DETECTION TEST
- Ultra-Violet Light System** 18

NOTE TO INSTALLER

This manual should be left with the equipment owner.

GENERAL

This user's guide provides information on maintaining Carrier 48K Series applied rooftop units to ensure reliable and efficient operation. Equipment maintenance should only be performed by qualified personnel. Use proper safety equipment when maintaining equipment and follow codes, regulations, and safety guidelines. Refer to the Advanced Controls, Operation, and Troubleshooting Guide for equipment troubleshooting and service instructions.

SAFETY CONSIDERATIONS





Improper installation, adjustment, alteration, service, maintenance, or use can cause explosion, fire, electrical shock, or other conditions which may cause death, personal injury, or property damage. Consult a qualified installer, service agency, or your distributor or branch for information or assistance. The qualified installer or agency must use factory-authorized kits or accessories when modifying this product. Refer to the individual instructions packaged with the kits or accessories when installing.

Follow all safety codes. Wear safety glasses, protective clothing, and work gloves. Have a fire extinguisher available. Read these instructions thoroughly and follow all warnings or cautions included in literature and attached to the unit. Affix any labels that ship with the unit or accessory installation instructions to the unit. Consult local building codes, the current editions of the National Fuel Gas Code (NFPA) NFPA 54/ANSI Z223.1, and the National Electrical Code (NEC)/National Fire Protection Association (NFPA) 70. Along with NFPA 90A for Ductwork and ventilation standards.

In Canada refer to the current editions of the National Standards of Canada CAN/CSA-B149.1 and 149.2 Natural Gas and Propane Installation Codes, and Canadian Electrical Code (CEC) CSA C22.1.

Recognize safety information. This is the safety-alert symbol . When you see this symbol on the unit and in instructions or manuals, be alert to the potential for personal injury. Understand the signal words DANGER, WARNING, and CAUTION. These words are used with the safety-alert symbol. DANGER identifies the most serious hazards which will result in severe personal injury or death. WARNING signifies hazards which could result in personal injury or death. CAUTION is used to identify unsafe practices which may result in minor personal injury or product and property

damage. NOTE is used to highlight suggestions which will result in enhanced installation, reliability, or operation.

SYMBOL	CODE	MEANING
	GHS02: Flammable	Flammable gas
	ISO 7000-0790 (2004-01)	Read operator's manual.
	ISO 7000-1659 (2004-01)	Service indicator: read technical manual.
	ISO 7000-1641 (2004-01)	Operator's manual: operating instructions

⚠ DANGER

If you smell gas, do not try to light any appliance. Do not touch any electrical switch or plug. Evacuate the building immediately and call the gas supplier. Follow the gas supplier's instructions. If you cannot reach your gas supplier, call the fire department.

⚠ DANGER

Si vous sentez une odeur de gaz, n'essayez pas d'allumer un appareil. Ne touchez aucun interrupteur ou prise électrique. Évacuez immédiatement le bâtiment et appelez le fournisseur de gaz. Suivez les instructions du fournisseur de gaz. Si vous ne parvenez pas à joindre votre fournisseur de gaz, appelez les pompiers.

⚠ WARNING

RISK OF FIRE OR EXPLOSION

If the information in this manual is not followed exactly, a fire or explosion may result causing property damage, personal injury or loss of life.

Do not store or use gasoline or other flammable vapors and liquids in the vicinity of this or any other appliance.

WHAT TO DO IF YOU SMELL GAS

- Do not try to light any appliance.
- Do not touch any electrical switch; do not use any phone in your building.
- Leave the building immediately.
- Immediately call your gas supplier from a neighbor's phone. Follow the gas supplier's instructions.
- If you cannot reach your gas supplier, call the fire department.

Installation and service must be performed by a qualified installer, service agency or the gas supplier.

⚠ AVERTISSEMENT

RISQUE D'INCENDIE OU D'EXPLOSION

Si les consignes de sécurité ne sont pas suivies à la lettre, cela peut entraîner la mort, de graves blessures ou des dommages matériels.

Ne pas entreposer ni utiliser d'essence ni autres vapeurs ou liquides inflammables à proximité de cet appareil ou de tout autre appareil.

QUE FAIRE SI UNE ODEUR DE GAZ EST DÉTECTÉE

- Ne mettre en marche aucun appareil.
- Ne toucher aucun interrupteur électrique; ne pas utiliser de téléphone dans le bâtiment.
- Quitter le bâtiment immédiatement.
- Appeler immédiatement le fournisseur de gaz en utilisant le téléphone d'un voisin. Suivre les instructions du fournisseur de gaz.
- Si le fournisseur de gaz n'est pas accessible, appeler le service d'incendie.

L'installation et l'entretien doivent être effectués par un installateur ou une entreprise d'entretien qualifié, ou le fournisseur de gaz.

⚠ WARNING

CARBON-MONOXIDE POISONING HAZARD

Failure to follow instructions could result in severe personal injury or death due to carbon-monoxide poisoning, if combustion products infiltrate into the building.

Check that all openings in the outside wall around the vent (and air intake) pipe(s) are sealed to prevent infiltration of combustion products into the building.

Check that furnace vent (and air intake) terminal(s) are not obstructed in any way during all seasons.

⚠ AVERTISSEMENT

RISQUE D'INTOXICATION AU MONOXYDE DE CARBONE

Si ces directives ne sont pas suivies, cela peut entraîner des blessures graves ou une intoxication au monoxyde de carbone pouvant causer la mort, si des produits de combustion s'infiltrent dans le bâtiment.

Vérifier que toutes les ouvertures pratiquées dans le mur extérieur autour du ou des tuyaux d'évent (et de la prise d'air) sont scellées de manière à empêcher l'infiltration de produits de combustion dans le bâtiment.

Veiller à ce que la ou les sorties de l'évent de l'appareil de chauffage (et la prise d'air) ne soient, en aucune façon, obstruées, quelle que soit la saison.

⚠ WARNING

FIRE HAZARD

Failure to follow this warning could result in severe personal injury and/or property damage.

Inlet pressure tap set screw must be tightened and 1/8 in. NPT pipe plug must be installed to prevent gas leaks.

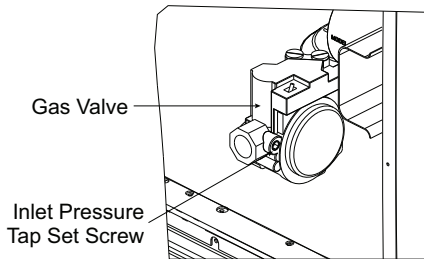

⚠ ADVERTISSEMENT

RISQUE D'INCENDIE

Le non-respect de cet avertissement pourrait entraîner des blessures graves et/ou des dommages matériels.

La vis de réglage du robinet de pression d'entrée doit être serrée et un bouchon de tuyau NPT de 1/8 po doit être installé pour éviter les fuites de gaz.

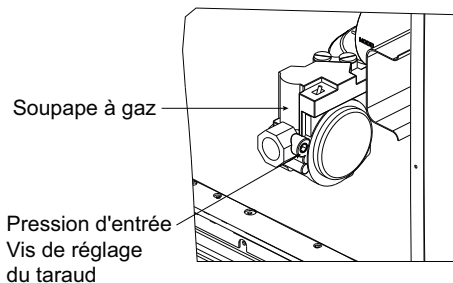

⚠ WARNING

FIRE HAZARD

Failure to follow this warning could result in severe personal injury and/or property damage.

Manifold pressure tap set screw must be tightened and 1/8 in. NPT pipe plug must be installed to prevent gas leaks.

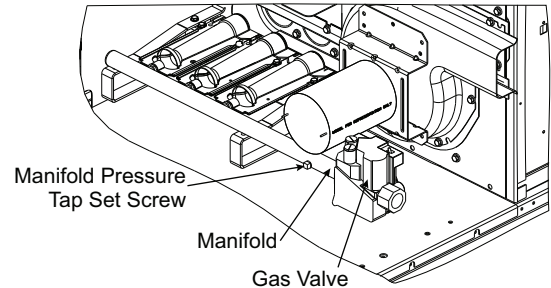

⚠ ADVERTISSEMENT

RISQUE D'INCENDIE

Le non-respect de cet avertissement pourrait entraîner des blessures graves et/ou des dommages matériels.

La vis de réglage du robinet de pression du collecteur doit être serrée et un bouchon de tuyau NPT de 1/8 po doit être installé pour éviter les fuites de gaz.

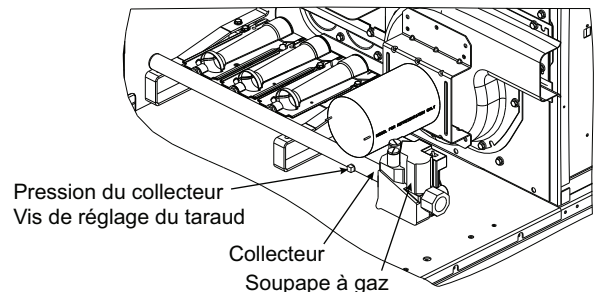

⚠ WARNING



This equipment may contain a UV-C LAMP. Look for this UV-C warning on panels or doors before opening. Disconnect UV-C power before opening access doors, removing panels, or installing, maintaining, or servicing UV-C lamps or fixtures. Do not operate UV-C with open access doors or with panels removed. Do not operate

UV-C outside of unit cabinet. Exposure to UV-C can cause harm to the eyes and skin. Review the UVC lamp accessory installation instructions for details on installing, testing, and maintaining UV-C lamps.

⚠ ADVERTISSEMENT



Cet équipement peut contenir une LAMPE UV-C. Recherchez ces avertissements UV-C sur les panneaux ou les portes avant de les ouvrir. Débranchez l'alimentation UV-C avant d'ouvrir les portes d'accès, de retirer les panneaux ou d'installer, d'entretenir ou de réparer des lampes ou des luminaires UV-C. N'utilisez pas de lampes UV-C en dehors du boîtier de l'appareil. L'exposition aux UV-C peut endommager les yeux et la peau. Consultez les instructions d'installation des accessoires de lampe UV-C pour plus de détails sur l'installation, le test et l'entretien des lampes UV-C.

⚠ WARNING

ELECTRICAL SHOCK HAZARD

Failure to follow this warning could result in personal injury or death.

Before performing installation, service, or maintenance on this unit, turn off the main power disconnect to the unit and install lock and lockout tag. Some equipment may have multiple power disconnects

⚠ ADVERTISSEMENT

RISQUE DE CHOC ÉLECTRIQUE

Le non-respect de cet avertissement pourrait entraîner des blessures corporelles, voire la mort.

Avant d'effectuer l'installation, l'entretien ou la maintenance de cet appareil, coupez l'alimentation principale de l'appareil et installez des verrous et des étiquettes de verrouillage. Certains équipements peuvent avoir plusieurs alimentations de courant.

⚠ WARNING

This equipment is not intended for use by persons (including children) with reduced physical, sensory, or mental capabilities, or lack of experience and knowledge, unless they have been given supervision or instruction concerning use of the appliance by a person responsible for their safety. Children should be supervised to ensure that they do not play with the appliance.

⚠ ADVERTISSEMENT

Cet équipement n'est pas destiné à être utilisé par des personnes (y compris des enfants) ayant des capacités physiques, sensorielles ou mentales réduites, ou un manque d'expérience et de connaissances, à moins qu'elles n'aient reçu une supervision ou des instructions concernant l'utilisation de l'appareil par une personne responsable de leur sécurité. Les enfants doivent être surveillés pour s'assurer qu'ils ne jouent pas avec l'appareil.

⚠ CAUTION

PERSONAL INJURY HAZARD

Failure to follow this caution may result in personal injury.

Sheet metal parts may have sharp edges or burrs. Use care and wear appropriate protective clothing, safety glasses and gloves when handling parts and servicing air conditioning equipment.

⚠ ADVERTISSEMENT

RISQUE DE BLESSURE CORPORELLE

Le non-respect de cette mise en garde peut entraîner des blessures corporelles.

Les pièces en tôle peuvent présenter des bords tranchants ou des bavures. Soyez prudent et portez des vêtements de protection appropriés, des lunettes de sécurité et des gants lors de la manipulation des pièces et de l'entretien des équipements de climatisation.

⚠ CAUTION

All possible ignition sources, including cigarette smoking, must be kept sufficiently far away from the site of work. This includes, but is not limited to, installation, repair, removal, and disposal of equipment.

⚠ AVERTISSEMENT

Toutes les sources d'inflammation possibles, y compris la fumée de cigarette, doivent être maintenues suffisamment loin du lieu de travail. Cela comprend, sans toutefois s'y limiter, l'installation, la réparation, le retrait et l'élimination de l'équipement.

MAINTENANCE ACCESS

See Fig. 1 and 2 for maintenance access. See Fig. 3 for key component locations.

⚠ CAUTION

PERSONAL INJURY

Disconnect UV emitter power before accessing unit interior. UV emitters may be powered separate from the unit.

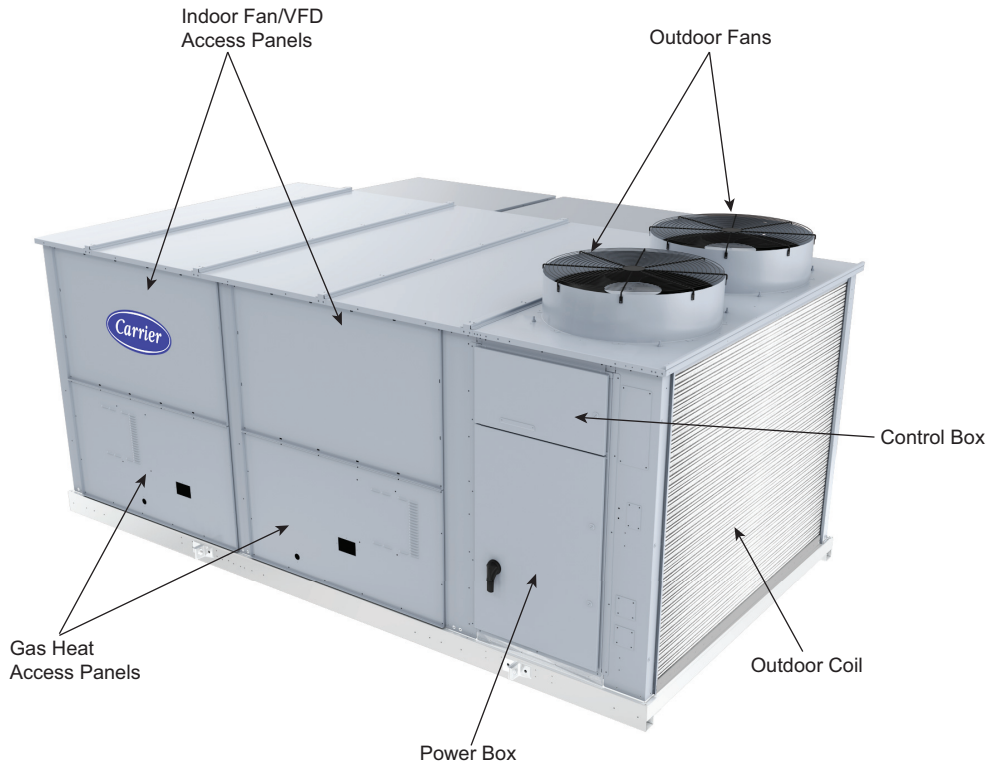

Fig. 1 – 48K Right Maintenance Access (Size 20-34 Shown)

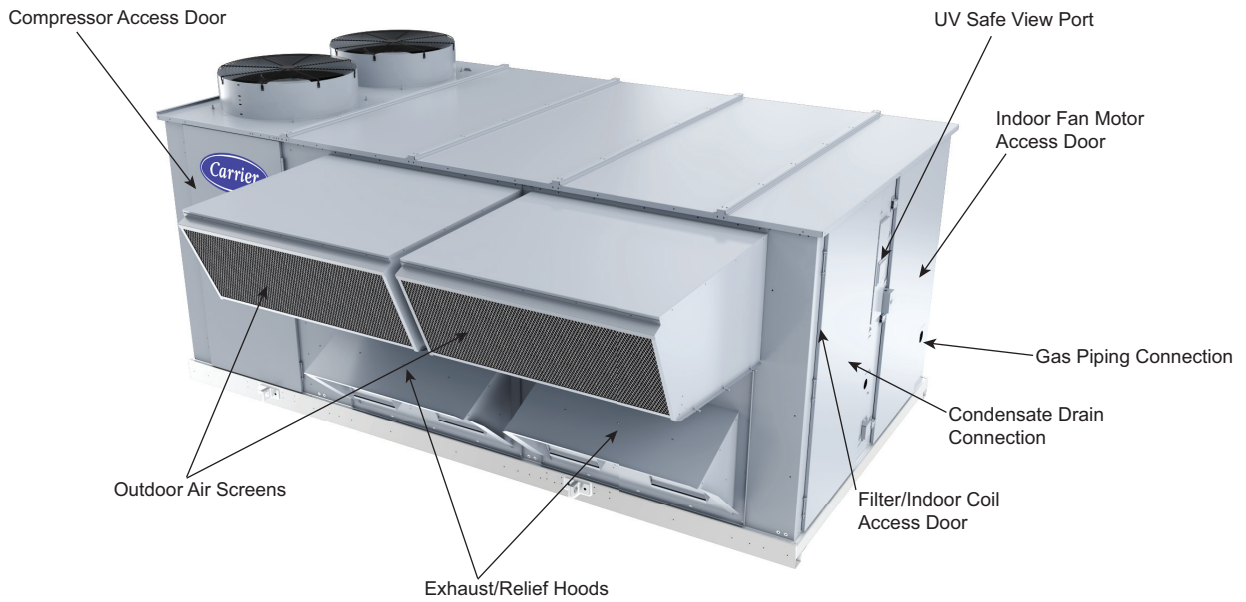

Fig. 2 – 48K Left Maintenance Access (Size 20-34 Shown)

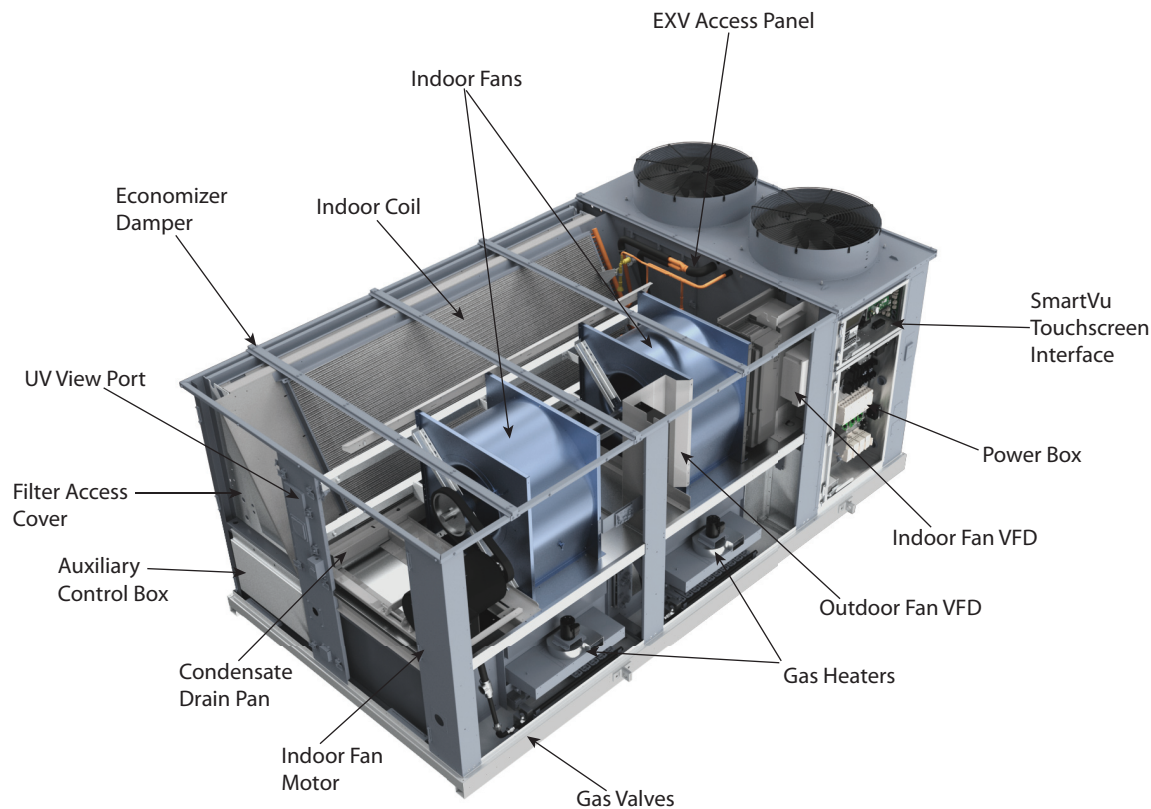

Fig. 3 — 48K Key Component Locations (Size 20-34 Shown)

Access Doors

Review the access doors for UV warnings prior to accessing the unit interior. After performing any maintenance or service on the unit, verify that all access doors are secured and that all door gaskets are in place to prevent water and air leaks.

ACCESS DOOR LATCH

All airside panels include three paddle flaps with latch bolts. Use a 7/16 wrench or socket to loosen all the latch bolts and rotate the paddle flat 90 degrees to allow the door to open. See Fig. 4 for latch bolt location.

ACCESS DOOR RETAINERS

Access door retainers are available as a factory-installed option. To use the access door retainer follow Steps 1-4.

1. Open the access door to the desired opening.
2. Pull up on the retainer rod so that the end is out of the retainer bracket.
3. Rotate the retainer rod toward the door bracket. See Fig. 5 for door bracket and retainer rod locations.
4. Insert the rod end into one of the holes in the door bracket. Open or close the door as needed to get the rod to line up with the hole in the bracket.

Control Box

The control box only contains low voltage (<110-v) power components. The control box access door is secured with cam latches. Use a flat head screwdriver to turn the cam latch 90 degrees to allow the door to open. See Fig. 6 for control box door cam latch locations.

The door is equipped with a catch to hold the door open. The catch latches automatically when the door is fully opened. Pull up on the latch knob to release the door to close it.

After accessing the door, ensure the door is fully closed and latched to prevent dirt and water ingress and prevent unauthorized access.

Power Box

⚠ CAUTION

PERSONAL INJURY

Disconnect all electrical power before accessing power box. Units may have more than one power feed (dual point power and end box).

The power box contains high voltage (≥ 110 -v) power components. The power box access door is secured with cam latches. Use a flat head screwdriver to turn the cam latch 90 degrees to allow the door to open. See Fig. 6 for power box door cam latch locations.

UNITS WITH NON-FUSED DISCONNECT

Units with the non-fused disconnect option include a unit power disconnect in the power box with a through-the-door interlocking handle. See Fig. 6 for disconnect handle location.

After opening the cam latches, turn the disconnect handle to the open position (beyond the Off position) to open the access door. When closing the door, the disconnect handle will also need to be turned to the open position.

The door is equipped with a catch to hold the door open. The catch latches automatically when the door is fully opened. Pull up on the latch knob to release the door to close it.

After accessing the door, ensure the door is fully closed and latched to prevent dirt and water ingress and prevent unauthorized access.

Electronic Expansion Valve (EXV) Access Panel

An EXV access panel is located in the outdoor section to allow easy access to EXVs for inspection or service. To remove the EXV access panel cover, rotate the 6 cam latches 90 degrees and use a flat head screwdriver or putty knife to pull out the top of the panel. When reinstalling the EXV access panel cover, ensure the cover is properly installed to prevent air and water leaks. See Fig. 7 for EXV access panel location.

Access Panels

After performing any maintenance or service on the unit, be sure all access panels are secured using all fasteners and that all seal strips are in place to prevent water and air leaks.

LATCH BOLT

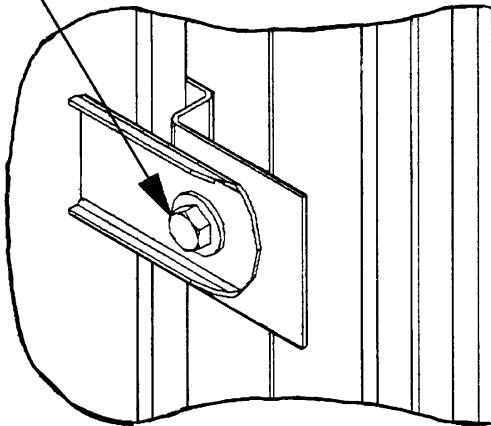

Fig. 4 – Access Door Latch Bolt

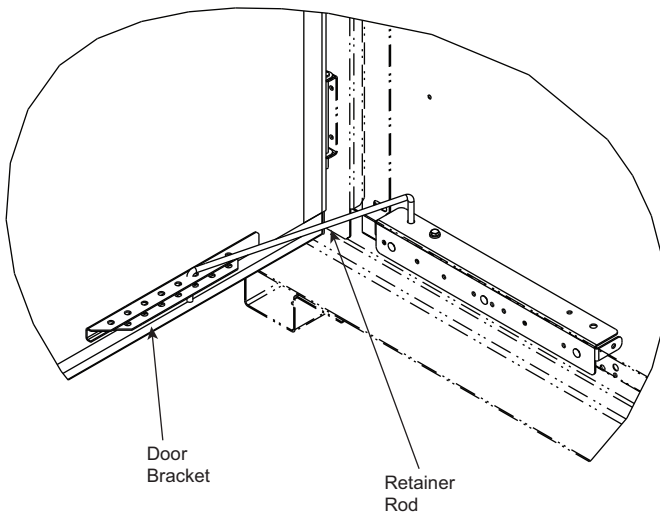

Fig. 5 – Access Door Retainer

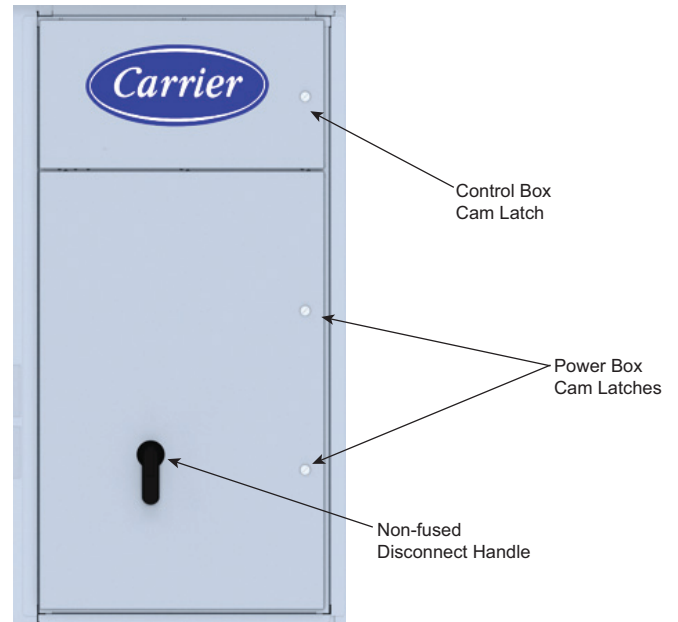

Fig. 6 – Control/Power Box Access

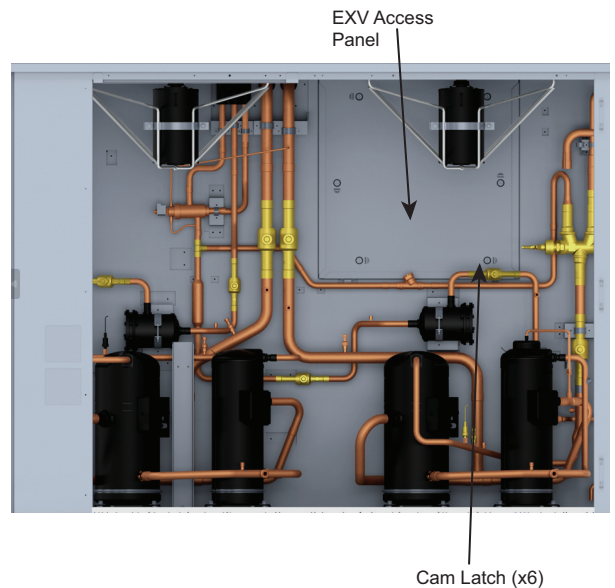

Fig. 7 – EXV Access Panel

ROUTINE MAINTENANCE

The following items should be part of a routine maintenance program. These parts should be checked 30 days after initial unit operation and then again, every one to two months, until a specific maintenance schedule for each can be identified for this equipment.

Monthly Inspection

- Check door latches are secure.
- Check door seals are in place.
- Inspect pre-indoor coil filters, replace if dirty.
- Inspect outdoor air inlet screens, clean if dirty.
- Inspect outdoor coil(s) (during cooling season), clean if dirty.
- Inspect indoor coil(s), clean if dirty.
- Inspect condensate drain, clean if dirty and clear if blocked.
- Inspect indoor fan system.
- Inspect indoor fan belt(s), tighten or replace as needed.
- Inspect indoor shaft fan bearings and coupling, lubricate as needed.
- Inspect power and control box.
- Check UV-light operation (if equipped).
- Review unit alarm history.

Cooling Season Start-Up

In addition to the monthly inspection items, these items should be checked at the beginning of each cooling season (or more often if local conditions and usage patterns dictate an extended cooling season):

- Inspect unit exterior.
- Inspect door gaskets and seals.
- Check that all electrical connections are tight.
- Check voltage and voltage imbalance for all power legs.
- Check indoor fan operation.
- Check indoor fan motor amp draw.
- Inspect indoor fan motor VFD.
- Check A2L mitigation system operation.
- Inspect EXVs, verify cables are tight.
- Inspect outdoor fans.
- Inspect indoor fan VFDs (if equipped).
- Check outdoor fan operation.
- Inspect refrigerant circuit piping.
- Check crank case heater operation.
- Clean condensate drain.
- Inspect compressors.
- Check compressor operation.
- Check cooling operation.
- Check compressor voltages and amp draws.
- Check refrigerant circuit pressures and temperatures.
- Check refrigerant circuit oil level.
- Check cooling air temperatures.
- Check Humidi-Mizer system operation (if equipped).
- Check economizer damper operation (if equipped).
- Check relief damper operation (if equipped).
- Check exhaust fan operation (if equipped).
- Shutdown heater (optional).

Heating Season Start-Up

In addition to the quarterly inspection items, these items should be checked at the beginning of each heating season (or more often if local conditions and usage patterns dictate an extended heating season):

- Inspect unit exterior.
- Check door gaskets and seals.
- Check that all electrical connections are tight.
- Check voltage and voltage imbalance for all power legs.
- Check indoor fan operation.
- Check indoor fan motor amp draw.
- Inspect heat exchanger.
- Inspect flue vents and flue hood.
- Check inducer fan operation.
- Check gas inlet pressure.
- Check heating operation.
- Check heating air temperatures, including temperature rise.
- Check combustion readings.
- Check economizer damper operation (if equipped).
- Check relief damper operation (if equipped).
- Check exhaust fan operation (if equipped).
- Disable cooling operation in SmartVu™ Control (optional).

MAINTENANCE INSTRUCTIONS

Indoor Coil Filters

IMPORTANT: Do not operate equipment without filters installed. Dirt and debris can collect on coils, heat exchangers, and fans, which can lead to equipment damage. This includes compressor failure, fan failure, or motor failure. Dirt and debris can also collect on heaters, which can cause fire or smoke.

IMPORTANT: Do not operate equipment with clogged filters. Clogged filters can lead to equipment damage, including compressor failure, fan failure, or motor failure.

FILTER INSPECTION

The pre-filter rack is in front of the indoor air coil and can be accessed from the filter/indoor coil access door.

Follow the steps below to inspect the filters.

1. Open the filter/indoor coil access door (tool required). Refer to Fig. 2 for access points.
2. Remove the bottom thumbscrew from the filter access cover. Save screw. Refer to Fig. 3 for filter access cover location and Fig. 8 thumbscrew locations.
3. While holding on to the cover flange, remove the top thumbscrew. Save the thumbscrews.
4. Lift up on the filter access cover until the cover lip is over the edge of the side panel and remove the cover. Save cover.
5. To reinstall the filter access cover, start by inserting the filter access cover lip behind the side panel rail. See Fig. 8 for cover lip location.
6. Line up the top hole in the filter access cover with the top thumbscrew nut in the side panel.
7. While holding the cover in place, insert the top thumbscrew. Do not tighten all the way.

8. Verify the cover is in the correct position and is fully covering the side panel opening.
9. Line up the bottom hole in the panel with the bottom thumbscrew in the side panel.
10. Insert the bottom thumbscrew and tighten.
11. Tighten the top thumbscrew.

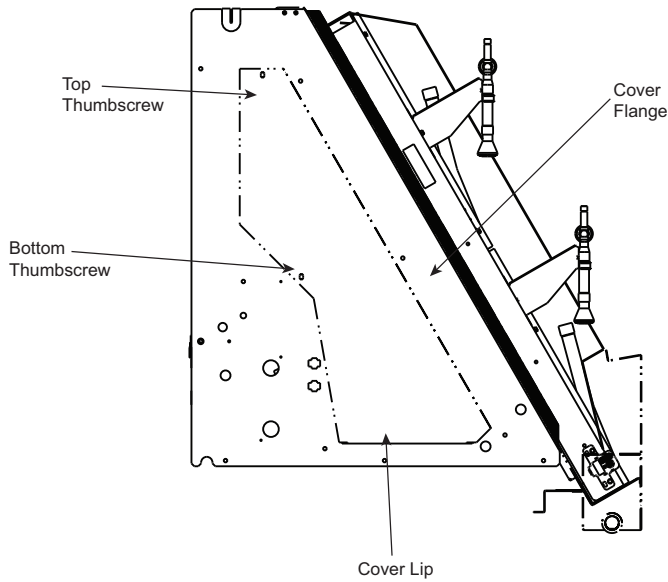

Fig. 8 – Filter Access Cover

FILTER REPLACEMENT

See Table 1 for filter type, size, and quantity by unit size and configuration. It is recommended to use the same filter type that the unit was ordered with. Changing the filter type may affect fan performance.

NOTE: Pre-filter racks are not field convertible between 2 and 4 inches.

Follow Steps 1-14 to inspect or replace the filters.

1. Follow Steps 1-4 outlined in section “FILTER INSPECTION” on page 8 to access the filter rack.

2. Slide the black filter clip outward to remove it from the filter rack. See Fig. 9 for 2 in. filter clip locations and filter rack example.
3. Remove the top right filter by pulling the bottom of the filter away from the middle filter rail and then sliding the filter down to remove it from the top filter rail.
4. A filter hook is included with all units for filter removal. The filter hook ships on the floor in front of the filter rack and is secured with zip ties.
5. Slide the remaining filters in the top filter rack down to the edge of the filter rack to remove. Use the filter hook as needed.
6. After all the top filters are out, remove the bottom right filter by pulling the top of the filter away from the middle filter rail and then sliding the filter up to remove it from the bottom filter rail.
7. Slide the remaining bottom filters down to the edge of the filter rack to remove, using the filter hook as needed.
8. To insert new filters, start with the bottom row of filters. See Fig. 9 for 2 in. filter orientation and dimensions. See Fig. 10 for 4 in. filter orientation in the filter rack.
9. Insert the bottom of the first filter into the bottom filter rail and then slide the top of the filter into the middle filter rail.
10. Slide the filter to the far end of the filter rack using the next filter or the filter hook.
11. Once all the bottom filters are in place, insert the first filter of the top row into the top filter rail and then slide the bottom of the filter into the middle filter rail.
12. Slide the filter to the far end of the filter rack using the next filter or the filter hook.
13. Once all the filters are in place, re-insert the filter clip.
14. Follow Steps 5-10 of the section “FILTER INSPECTION” on page 8 to re-install the filter access panel.

NOTE: Use a marker to write the filter change date on the filter or on a piece of masking tape attached to the filter or filter access door.

NOTE: Consult with customer regarding filter disposal.

Table 1 – Pre-Filters by Unit Size and IAQ Option^a

48K UNIT SIZE (POS 7,8)	IAQ OPTION (POS 18)	FILTERS 1 AND 2 (TYPE)	FILTER 1 QTY...SIZE	FILTER 2 QTY...SIZE
20,26,30,34,40,50	0	2 in. MERV 7	10...20 in.x 24 in.x 2 in.	N/A
	1,2	2 in. MERV 8		
	3,4	4 in. MERV 8	5...20 in.x 24 in.x 4 in	5...20 in. x 20 in. x 4 in.
	5,6	4 in. MERV 13		
60	0	2 in. MERV 7	16...20 in.x 24 in.x 2 in	N/A
	1,2	2 in. ME8V 8		
	3,4	4 in. MERV 8	8...20 in. x 24 in. x 4 in.	8...20 in. x 20 in. x 4 in.
	5,6	4 in. MERV 13		

NOTE(S):

- a. Print out a copy of Table 1 or write the filter type, quantity, and size on the inside of the filter access door or on the filter access panel. Use an adhesive label if necessary.

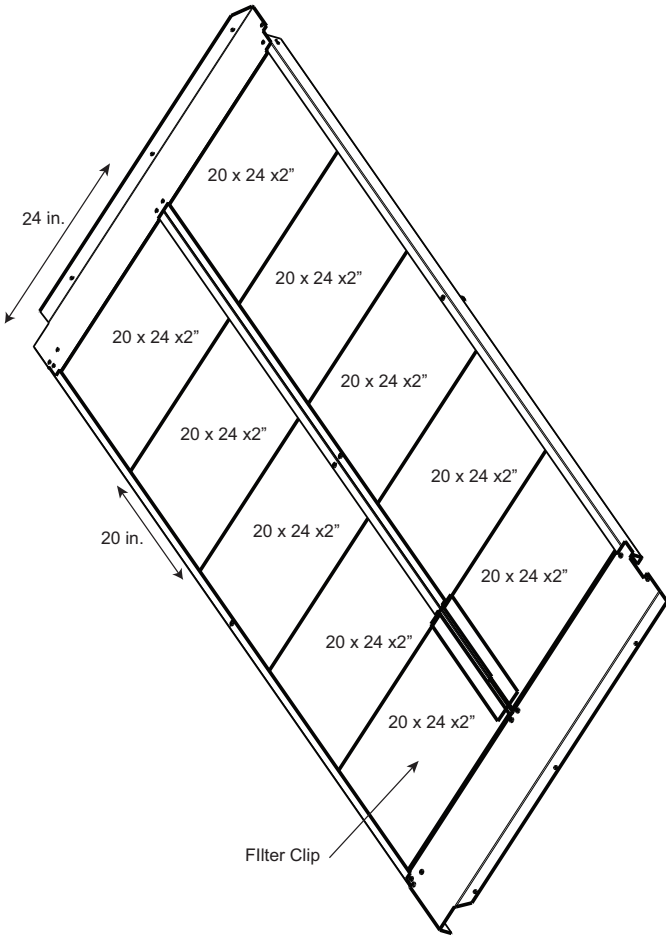

**Fig. 9 — Filter Clip and 2 in. Filter Orientation
(Sizes 20-50 Shown)**

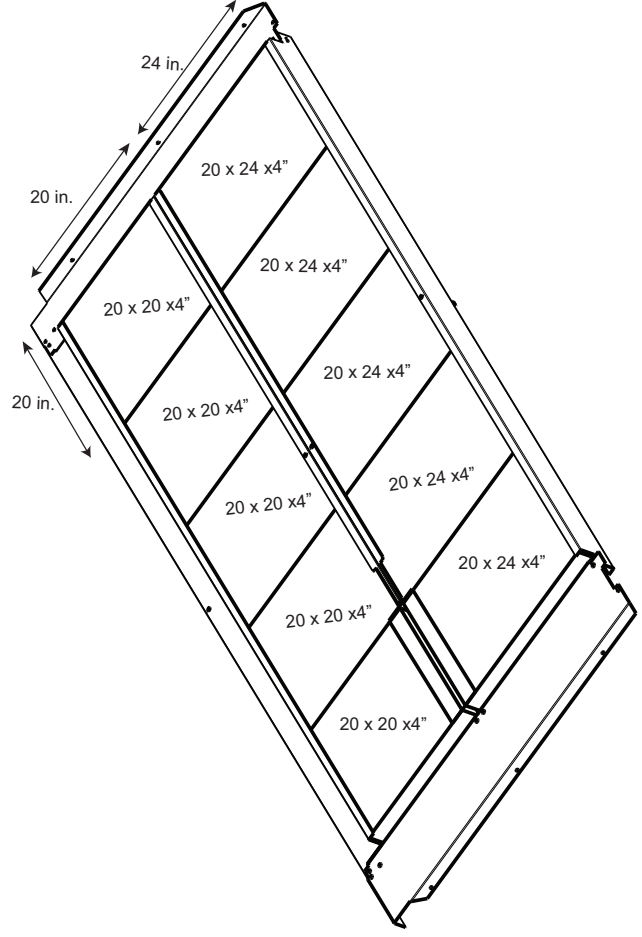

Fig. 10 — 4 in. Filter Orientation (Sizes 20-50 Shown)

FILTER CHANGE REMINDER

The SmartVu control can be configured to set a filter change reminder alert based on filter hours or based on a filter status switch (factory-installed or field-installed accessory).

Refer to the unit installation instructions for directions on changing the alert type (hours or status switch) and on adjusting the filter status switch trigger point. Refer to the filter status switch accessory installation instructions for field installation of the filter status switch.

Review the filter manufacturer's recommendation for final filter pressure drop. For pleated filters, including the factory pleated filters, the final filter pressure drop is typically no more than 1 in. wg.

Outdoor Coils

Inspect outdoor coils for cleanliness. For units with hail guards, remove the hail guards to inspect the coil. Keeping the outdoor coil clean will help maintain proper operation of the unit.

Use a non-metallic brush to remove any large debris from both coil faces. Note any damage or dark spots on the coil. For units with hail guards, use the non-metallic brush to clean the hail guards before re-installing.

OUTDOOR COIL RINSING

Coil rinsing is recommended at least once per year and more frequently as required by environmental conditions.

IMPORTANT: Do not spray water on electrical components or sensors in the outdoor section.

After the coil surface debris has been removed, use low pressure water to rinse the coil. Rinse the coil in the opposite direction of airflow (rinse back side of coil to front side of coil) to prevent debris ingress.

The back face of the coil can be accessed through the outdoor section access door (tool required). For units with hail guards, rinse the hail guards prior to reinstallation.

NOTE: Consult with customer regarding water usage and gray water disposal.

IMPORTANT: Do not use high pressure water to clean the coil.

After the coil is rinsed, make sure the coil is not packed with water before enabling cooling operation. Operating cooling with a coil clogged with water can cause operational issues. Use low pressure air to remove water trapped in the coil. Gently patting the coil can also help to push water out of the coil. Turning on the condenser fans in service mode can also help to pull water from the coil.

IMPORTANT: Do not enable cooling operation if the outdoor coil is clogged with water.

OUTDOOR COIL CLEANING

When rinsing does not clean the coil of grease or other contaminants, chemical coil cleaning is recommended. Elimination of contamination and removal of harmful residues will greatly increase the life of the coil and extend the life of the unit.

IMPORTANT: Do not spray coil cleaner on electrical components or sensors in the outdoor section.

NOTE: Consult with customer regarding coil cleaner usage, gray water disposal, and cleaner disposal.

Periodic cleaning with Totaline® coil cleaners can help extend the life of the coil. A variety of coil cleaners are available from Totaline based on type of coil contamination.

When using third-party coil cleaners, ensure the coil cleaner is microchannel coil safe for un-coated outdoor coils or epoxy safe and microchannel coil safe for e-coated outdoor coils.

Follow coil cleaner manufacturer's directions for cleaner preparation and coil cleaning.

IMPORTANT: Do not use acid or coil brighteners to clean the coil.

After the coil has been cleaned, make sure the coil is not packed with water before enabling cooling operation. Enabling cooling operation with a coil clogged with water can cause operational issues. Use low pressure air to remove water trapped in the coil. Gently patting the coil can also help to push water out of the coil.

IMPORTANT: Do not use "enable cooling operation" if the outdoor coil is clogged with water.

Indoor Coils

CAUTION

PERSONAL INJURY

Disconnect UV emitter power before accessing unit interior. UV emitters may be powered separate from the unit.

Access the right side of the indoor coil through the filter/indoor coil access door (tool required). Refer to Fig. 2 for filter and coil access location. Inspect the face of the indoor coil for cleanliness. Keeping the indoor coil clean will help maintain proper operation of the unit. The indoor coil can be accessed through the filters/indoor fan access door.

For units with Humidi-Mizer dehumidification, also inspect the reheat coil for cleanliness.

Use a non-metallic brush to remove any large debris from the face of the coils. Note any damage or dark spots on the coil. Use a fin comb to straighten any bent fins. The far side of the indoor coil can be accessed from the EXV access panel. Refer to Fig. 7 for EXV location.

INDOOR COIL RINSING

Coil rinsing is recommended at least once per year and more frequently as required by environmental conditions.

NOTE: Consult with customer regarding water usage and gray water disposal.

IMPORTANT: Protect the EXV cable connectors prior to rinsing the indoor coils. Do not directly spray the EXVs.

IMPORTANT: DO not spray water on the UV emitters.

Remove the mist eliminators to access the back side of the indoor coil. Use low pressure water to rinse the coil. Rinse the coil in the opposite direction of airflow (rinse back side of coil to front side of coil) to prevent debris ingress. For units with Humidi-Mizer system also rinse the coil in the opposite direction of airflow. Use the low-pressure water to rinse the moisture eliminators prior to reinstallation.

IMPORTANT: Do not use high pressure washers to clean the coil.

After the coil is rinsed, make sure the coil is not packed with water before enabling cooling operation. Operating cooling with a coil clogged with water can cause operational issues. Use low pressure air to remove water trapped in the coil.

IMPORTANT: Do not use “enable cooling operation” if the outdoor coil is clogged with water.

INDOOR COIL CLEANING

When rinsing does not clean the coil of grease or other contaminants, chemical coil cleaning is recommended. Elimination of contamination and removal of harmful residues will greatly increase the life of the coil and extend the life of the unit. For units that include mist eliminators, remove the mist eliminators.

NOTE: Consult with customer regarding coil cleaning usage, water gray disposal, and cleaner disposal.

IMPORTANT: Protect the EXV cable connectors prior to cleaning the indoor coils. Do not directly spray the EXVs.

Periodic cleaning with Totaline coil cleaners can help extend the life of the coil. A variety of coil cleaners are available from Totaline based on type of coil contamination.

When using third-party coil cleaners, ensure the coil cleaner is aluminum/copper coil safe for un-coated indoor coils or epoxy safe and aluminum/copper coil safe for e-coated indoor coils.

For units with Humidi-Mizer dehumidification system, clean the coil with an epoxy and microchannel coil safe cleaner.

Follow coil cleaner manufacturer’s directions for cleaner preparation, coil cleaning, and rinsing.

IMPORTANT: Do not use acid or coil brighteners to clean the coil.

After the indoor coils have been cleaned, make sure the coil is not packed with water before enabling cooling operation. Operating cooling with a coil clogged with water can cause operational issues. Use low pressure air to remove water trapped in the coil. Gently patting the coil can also help to push water out of the coil.

IMPORTANT: Do not use “enable cooling operation” if the outdoor coil is clogged with water.

CLEANING COILS WITH AIR

For applications where using water or liquid cleaners is not acceptable, a low-pressure vacuum or low pressure compressed air may be used to clean the coils. Clean in the opposite direction of the airflow. Ensure the vacuum or compressed air does not damage the coil fins.

Indoor Fan System

⚠ CAUTION

PERSONAL INJURY
 Disconnect UV emitter power before accessing unit interior. UV emitters may be powered separate from the unit.

⚠ CAUTION

PERSONAL INJURY
 Disconnect all electrical power before accessing unit interior. Units may have more than one power feed (dual point power).

Inspect the indoor fan system periodically to ensure proper fan operation. The indoor fan motor and the right most indoor fan can be accessed through the indoor fan access door (tool required). The remaining fans are accessed through the indoor fan/VFD access panels (tool required). Refer to Fig. 1-3 for component locations.

INSPECT BELTS

Inspect fan belt(s) for signs of fraying, wear, or cracking that could lead to belt failure. Spin the fan shaft to fully inspect the inside and outside of the fan belt. Replace belt as necessary. Check belt tension and adjust as necessary. See Table 2 for fan belt usage and details.

BELT REPLACEMENT

1. Disconnect unit power, lock-out/tag-out.
2. Loosen motor mounting nuts and bolts. See Fig. 11 for nut and bolt locations and installation example.
3. Loosen fan motor nuts.
4. Turn motor jacking bolts to move motor mounting plate left, to reduce belt tension, which allows removal of the belts. Remove and dispose of the used belt(s). See Table 2 for belt usage and tension.
5. Install the new belt(s).
6. Adjust belt tension.

NOTE: Keep record of the the belt replacement date.

NOTE: If spare belt(s) are stored in the fan section of the unit, make sure to secure the belt(s).

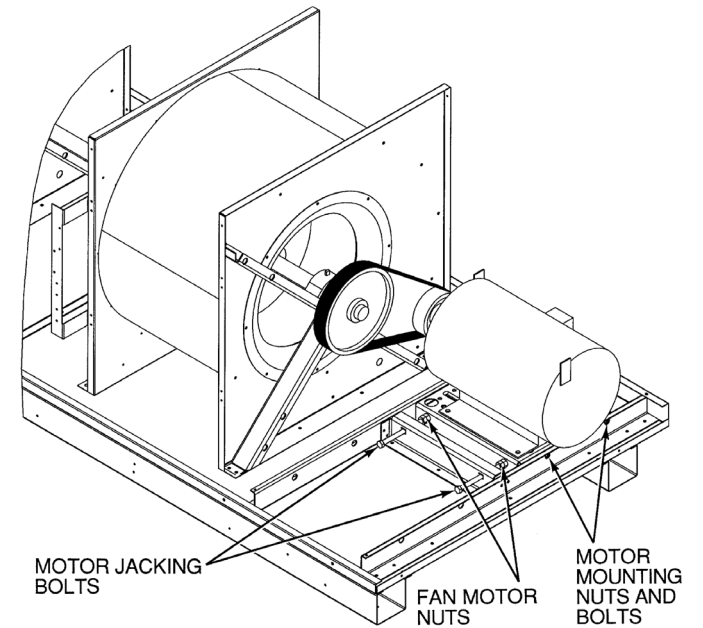

Fig. 11 — Belt Tension Adjustment

ADJUST BELT TENSION

1. Disconnect unit power, lock-out/tag-out.
2. Loosen motor mounting nuts and bolts. Refer to Fig. 11 for nut/bolt locations and installation example.
3. Loosen fan motor nuts.
4. Turn motor jacking bolts to move motor mounting plate left or right for proper belt tension. See Table 2 for belt usage and tension.
5. Tighten nuts.
6. Adjust nuts and bolts on mounting plate to secure motor in fixed position.
7. Restore power to unit.
8. Perform fan test to check belt. A slight bow should be present in the belt on the slack side of the drive while running under full load. Adjust as necessary.

NOTE: Recheck belt tension after 24 hours of operation.

INSPECT FAN AND MOTOR SHEAVES

Inspect the fan and motor sheaves for excessive wear. Turn fan sheaves while inspecting sheaves. Replace as necessary. Check sheave alignment using a straightedge and adjust as necessary. See Fig. 12 for evaporator/fan alignment and adjustment example.

SHEAVE ALIGNMENT

1. Disconnect unit power, lock-out/tag-out.
2. Loosen fan shaft pulley bushing.
3. Slide fan pulley along fan shaft.
4. Make angular alignment by loosening motor from mounting plate.
5. Retighten pulley.
6. Restore power to the unit.

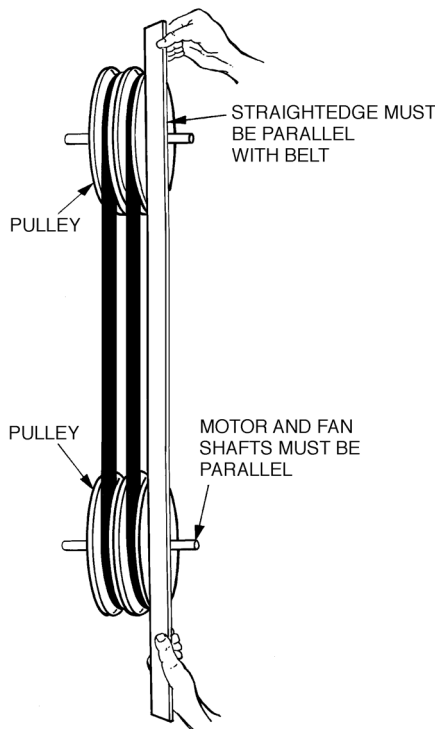

Fig. 12 — Evaporator/Fan Alignment and Adjustment

Table 2 — Indoor Fan Belt Usage^a

MOTOR HP	48K UNIT SIZE	VOLTAGE (v-Ph-Hz)	BELT PART NO.	BELT SIZE NO.	BELT QTY
5	20,26,30	All	KR29BF056	BX56	1
10	20,30,34,40	All	KR29BF050	BX50	2
	26	All	KR29QA057	5VX570	1
15	20,26,30,34,40,50	All	KR29QA053	5VX530	2
20	26,30,34	All	KR29QA053	5VX530	2
	40,50,60	All	KR29QA055	5VX550	2
25	34	All	KR29QA053	5VX530	2
	40	All	KR29QA059	5VX590	2
	50	All	KR29QA057	5VX570	2
	60	All	KR29QA053	5VX530	3
30	50	All	KR29QA057	5VX570	2
	60	All	KR29QA055	5VX550	3
40	60	575	KR29QA057	5VX570	3
	60	208/230,460	KR29QA065	5VX530	3

NOTE(S):

- a. This table lists the factory-installed belt sizes. Belt sizes may be field changed during air balancing. Verify unit installed belt size prior to ordering new belts.

INSPECT FAN SHAFT BEARINGS

Inspect the fan shaft bearings and coupler (60 ton units only) to ensure they contain a grease charge. A loss of fan bearing lubrication can cause catastrophic fan failure.

LUBRICATE FAN SHAFT BEARINGS AND COUPLER

In mild climates, lubricate the fan shaft bearings and the fan shaft coupler (60 ton units only) at least every 4-6 months or 2500 operating hours, whichever comes first.

For humid climates, lubricate the fan shaft bearings and the fan shaft coupler (60 ton units only) at least every month as high humidity can degrade the lubricant.

Lubrication may be required more frequently based on operating conditions or environment. See below for recommended lubricants:

MANUFACTURER	LUBRICANT
Texaco	Regal AFB-2 ^a
Mobil	Mobilplex EP No. 1
Sunoco	Prestige 42
Texaco	Multifak 2

NOTE(S):

- a. This is a preferred lubricant because it contains ruse and oxidation inhibitors.

IMPORTANT: Do not over lubricate bearings or coupler.

Units without extended lubrication lines

The right most fan shaft bearing can be accessed from the indoor fan motor access door. The far indoor fan shaft bearing and fan coupler can be accessed from the indoor fan/VFD access panels. Refer to Fig. 1 for component locations.

Use a hand grease gun to install lubricant using the 1/4 in. grease fitting on the top of the bearing and coupler. Turn the fan shaft while lubricating. Stop when a light bead of grease is visible at the bearing seal.

Units with extended lubrication lines

Units with the service pack or low ambient options will include extended lubrication lines for the far fan shaft bearings and fan shaft coupler. The right most indoor fan shaft bearing and the lubrication port can be accessed from the indoor fan motor access door. Refer to Fig. 1 for indoor fan access location.

Observe the condition of the grease in the lube lines and clear out any older grease as long durations in the lube lines will cause discoloration and loss of the lubrication capability.

Use a hand grease gun to install lubricant using the 1/4 in. grease fitting on the top of the right most fan bearing. Turn the fan while lubricating. Stop lubricating when a light bead of grease is visible at the bearing seal.

To lubricate the additional fan bearings and fan couplings, use the lubrication ports on the lubrication access bracket located near the top of the right most fan assembly. See Fig. 13 for 60 ton unit fan shaft lubrication. When using the extended lubrication lines for the first time, it is recommended to observe the fan bearings during lubrication and count the number of pumps needed until a light bead of grease is visible at the bearing seal. Turn the fan while lubricating. Once a light bead of grease is visible at the bearing seal, stop lubricating and record the number of pumps.

NOTE: Use a marker to write the number of grease pumps on the lubrication access panel or indoor fan motor access door. Use an adhesive label if necessary.

LUBRICATE INDOOR FAN MOTOR

If the indoor fan motor bearings have grease fittings, they will require periodic lubrication. Refer to the fan motor manufacturer's instructions for lubrication frequency and the type of lubricant to be used.

INSPECT INDOOR FAN MOTOR VARIABLE FREQUENCY DRIVE (VFD)

⚠ CAUTION
PERSONAL INJURY
Disconnect the power to the VFDs for a minimum of 5 minutes and check for residual power before accessing the VFDs.

Visually inspect VFD, cooling fan, and heat exchanger. Follow manufacturer's direction on cleaning fan and heat exchanger. Tighten electrical connections.

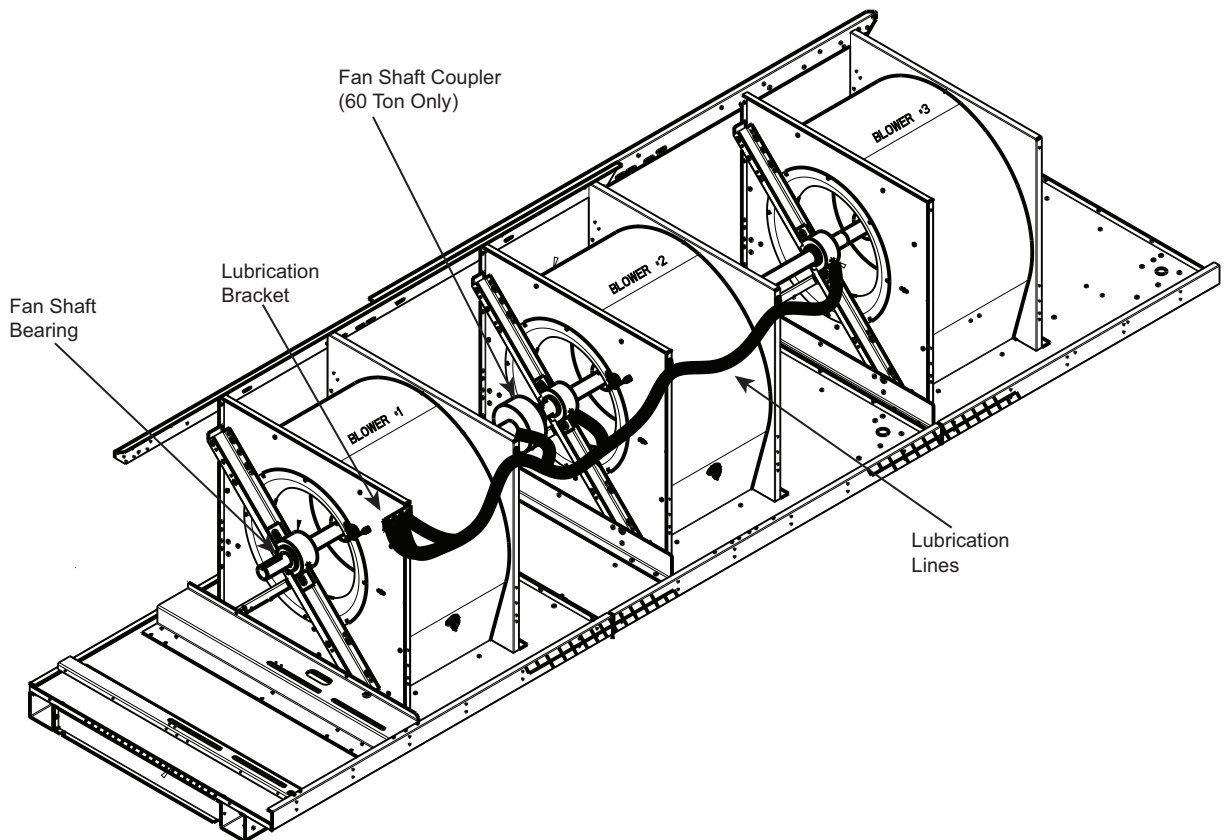

Fig. 13 — Fan Shaft with Extended Lubrication Lines (60 Ton Units)

Gas Heating System

⚠ DANGER

FIRE AND EXPLOSION HAZARD

1. Do not turn off the electrical power to unit without first turning off the gas supply.
2. Before attempting to start the gas heating section, familiarize yourself with all the procedures that must be followed.
3. Never attempt to manually light the burners on the unit with a match, lighter, or any other flame. If the electric sparking device fails to light the burners, refer to the shutdown procedures, then call your dealer as soon as possible.

If you do not follow these instructions exactly, a fire or explosion may result, causing property damage, injury, or loss of life.

⚠ WARNING

Burners will light automatically. Do not attempt to light by hand; personal injury may result.

⚠ WARNING

Should overheating occur or the gas supply fail to shut off, shut off the manual gas valve to the unit before shutting off the electrical supply.

⚠ AVERTISSEMENT

En cas de température excessive, ou s'il est impossible de couper l'alimentation en gaz, fermer le robinet manuel d'alimentation en gaz du générateur d'air chaud avant de couper l'alimentation électrique.

INSPECT HEATING SYSTEM

Prior to starting up the gas heating system, perform a visual inspection of the heater conditions. Refer to Fig. 1 for heater access. To inspect the heating system follow Steps 1-7.

1. Using the SmartVu touchscreen, login with the user password (1111).
2. Navigate to the Start/Stop screen press the Disable button to disable unit operation.
3. Set Auto-Restart to Off.
4. Shut off the gas supply valve.
5. Disconnect and lockout/tag-out unit power.
6. Remove the heater access panels. See Fig. 14 for gas valve and gas heat section location.
7. Inspect the heater components (including the burners, manifold, inducer fan, etc.) for dirt, debris, soot, or rust.

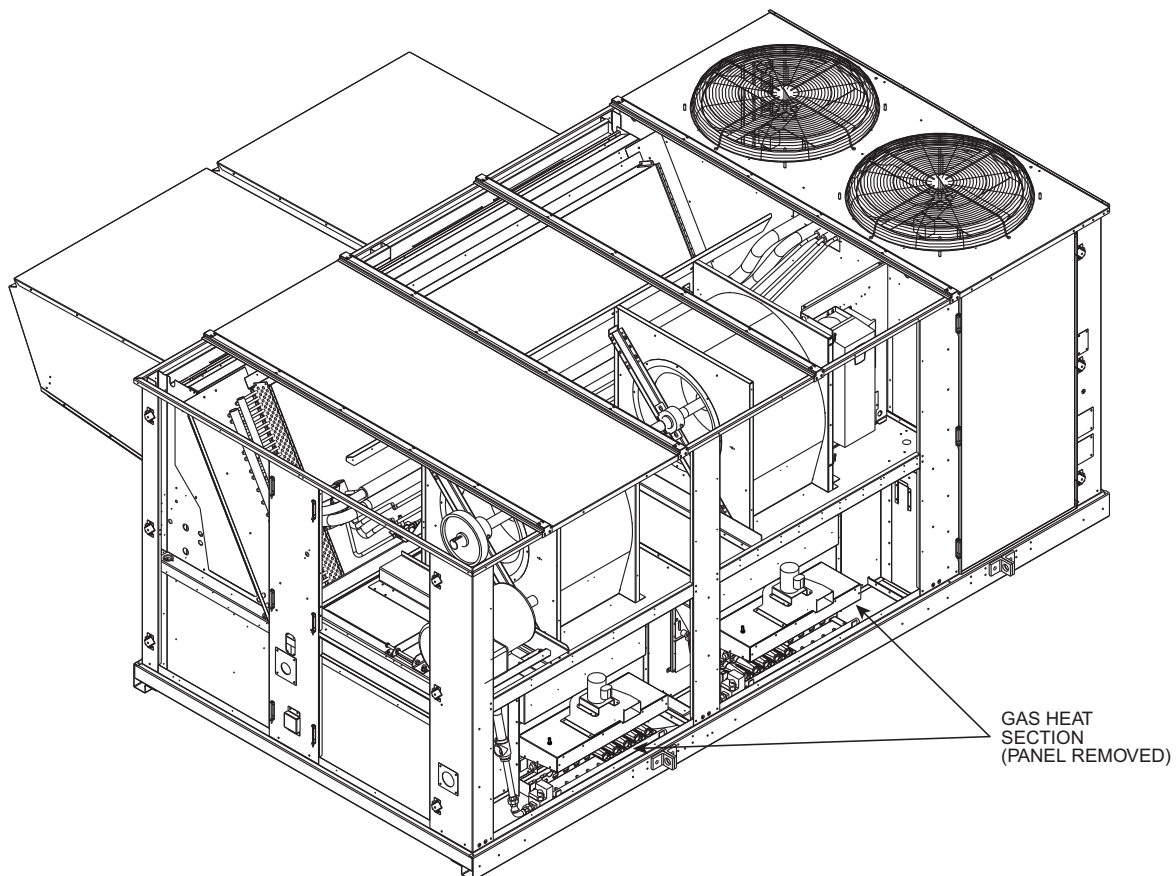

Fig. 14 — Gas Heating System Access

HEATING SYSTEM START-UP

After inspecting the heating system, start up the heating system by following Steps 1-12.

1. Remove the heat access panels. Refer to Fig. 1 and 2 for maintenance access component locations.
2. Locate the two (for 20-50 ton units) or three (for 60 ton units) gas valves in the unit. See Fig. 15 for gas valve locations.
3. Verify that the gas supply valve is shut off.
4. Move the switch on all internal gas valves from the “ON” position to the “OFF” position. See Fig. 16 and 17 for examples of gas valve switch in the on and off positions.
5. Turn on the gas supply valve.
6. Wait 5 minutes. If you smell gas, shut off the gas valve.
7. Move the switch on all gas valves to the “ON” position. See Fig. 16 for example of the valve in the on position.
8. Restore unit power.
9. Use the Service Run test to confirm and check heater operation. Refer to the unit Installation Instructions for guidance on using the Service Run function and for the gas heater start-up checklist.
10. Once the start-up check is complete, reinstall the heater access panels.
11. Using the SmartVu touchscreen, login with the user password (1111).
12. Navigate to the Start/Stop screen and set the unit to Enable by pressing the Enable button, to restore normal operation, or press Disable to keep the unit disabled.

⚠ WARNING

If the main burners fail to light or the blower fails to start, shut down gas heating section and call your trained service professional for service. Failure to follow these requirements could result in serious personal injury.

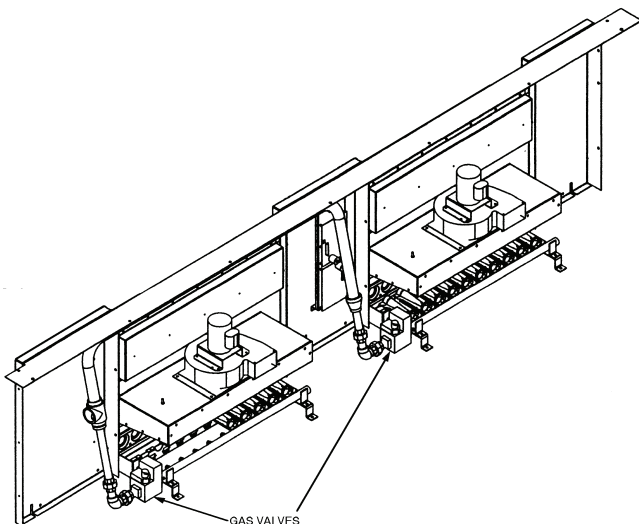

Fig. 15 — Gas Valve Locations (Detail View)

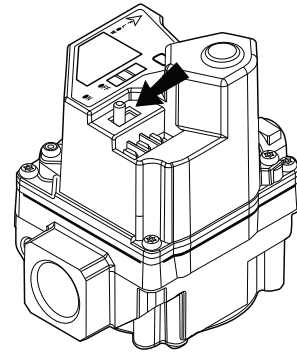

Fig. 16 — Gas Valve Switch - ON

HEATING SYSTEM SHUTDOWN

Follow Steps 1-12 for shutdown instructions.

1. Using the SmartVu touchscreen, login with the user password (1111).
2. Navigate to the Start/Stop screen press the Disable button to disable unit operation.
3. Set Auto-Restart to Off.
4. Disconnect the electrical power to the unit and apply lock-out/tag-out.
5. Turn of the gas supply valve.
6. Remove the heat access panels.
7. Locate the two (20-50 ton units) or three (60 ton units) gas valves in the unit. Refer to Fig. 14 and 15 for gas valve location.
8. Move the switch on all gas valves to the “OFF” position. See Fig. 17 for example the valve in the off position.
9. Replace the heat access panels.
10. Restore the unit power.
11. Using the SmartVu touchscreen, login with the user password (1111).
12. Navigate to the Start/Stop screen and set the unit to Enable by pressing the Enable button, to restore normal operation, or press Disable to keep the unit disabled.

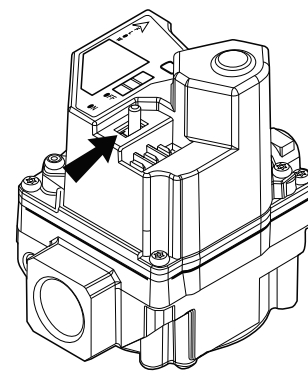

Fig. 17 — Gas Valve Switch - OFF

Outdoor Intake and Relief

OUTDOOR AIR SCREENS

Periodically inspect the outdoor air screens. Use a non-metallic brush to remove large debris from the screens. Rinse the screens periodically to remove any smaller debris. If the screens are very dirty or greasy, use a stainless-steel safe cleaner to clean the screens.

To remove the outdoor air screens follow Steps 1-4.

1. Remove the screws from the screen cover. Save the screws.
2. Remove the screen cover. See Fig. 18 for hood screen locations.
3. Slide the vertically mounted filters up and out of the hood.
4. The horizontally mounted screens can be left in place for rinsing or cleaning.

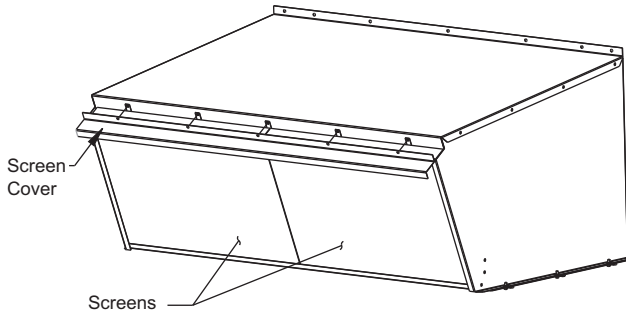

Fig. 18 — Outdoor Air Hood Screens

ECONOMIZER DAMPER

Inspect the economizer damper for any damage or wear. Use the component test function in the SmartVu control to modulate the actuator between open and closed. Listen for any unusual sounds and observe any binding.

BAROMETRIC RELIEF SYSTEM

Inspect the barometric relief system. Ensure the barometric dampers can move freely.

POWER EXHAUST

Inspect the power exhaust systems. Verify the barometric dampers can move freely. Inspect the belts and blower assembly and tighten the VFD electrical connection (high-capacity power exhaust only). Use the component test function in the SmartVu control to verify exhaust fan operation.

Electrical Connections

⚠ CAUTION

PERSONAL INJURY

Disconnect power before accessing electrical components. Wait a minimum of 5 minutes and check for residual power before accessing components with capacitors, like variable frequency drives (VFD).

Verify electrical connections are tight and secure. A loose electrical connection can cause operational issues and may lead to equipment damage.

Refrigerant Circuit

⚠ CAUTION

PERSONAL INJURY

Disconnect power before accessing outdoor section of unit.

Inspect the refrigerant circuit for signs of leaks or damage. Verify all service and isolation valves are open prior to system operation.

ELECTRONIC EXPANSION VALVES (EXVS)

The electronic expansion valve can be accessed through the EXV access panel. Refer to Fig. 7 for EXV access panel. Inspect the EXVs for leaks or other signs of wear. Verify the EXV connector cables are tight. Use the component test function in the SmartVu control to modulate the EXV position. Listen for operation confirmation and signs of grinding or sticking.

COMPRESSORS

The compressors are accessed through the compressor access door. Refer to Fig. 2 for compressor locations. Inspect the compressors for any signs of damage or leaks. Tighten the compressor power terminals.

OUTDOOR FANS

The outdoor fans are accessed through the compressor access door. Refer to Fig. 2 for compressor access door location. Spin the outdoor fans by hand to verify free rotation. Check the gap between the fan and fan shroud.

INSPECT OUTDOOR FAN MOTOR VARIABLE FREQUENCY DRIVE (VFD)

⚠ CAUTION

PERSONAL INJURY

Disconnect the power to the VFDs for a minimum of 5 minutes and check for residual power before accessing the VFDs.

Visually inspect VFD, cooling fan, and heat exchanger. Follow manufacturer's direction on cleaning fan and heat exchanger. Tighten electrical connections.

A2L Leak Dissipation System

All 48K Series units include a factory-installed leak dissipation system consisting of two leak detection sensors installed in the indoor section of the unit and a leak dissipation board installed on the indoor fan side of the unit. See Fig. 19 on page 18 for dissipation system component locations.

NOTE: Some early production units include an additional leak detection sensor installed in the power box and a leak dissipation board in the outdoor section. This additional board and sensor are not required and may be disabled in the unit controls. The unit will not respond to a leak detected from the outdoor sensor or a test from the dissipation board when disabled in the unit control.

SENSOR CALIBRATION

The leak detection sensors are self-calibrating and do not require field calibration. The leak detection system will issue an alert if a sensor is outside of the calibration range and requires replacement. Refer to the Advanced Controls, Service, and Troubleshooting guide for more information.

LEAK DETECTION TEST

IMPORTANT: Make sure all air terminal units, balancing dampers, or fire dampers are open prior to testing the A2L leak dissipation system.

It is recommended to test the A2L leak dissipation system response at cooling start-up (at a minimum). To test the A2L leak dissipation system follow Steps 1-9.

1. With the unit powered on, access the SmartVu touch screen in the control access panel.
2. Navigate to the Start/Stop screen and disable the unit by pressing the disable unit button.
3. Locate the A2L leak dissipation cover on the indoor fan/VFD access panel. Refer to Fig. 1 for access panel location.
4. Remove and save the cover and screws.
5. Locate the test button on the A2L leak dissipation board. See Fig. 19 for dissipation board details.
6. Press the test button on the A2L leak dissipation board for 1 second. This will force the unit into leak dissipation mode for 60 seconds.
7. Access the Home screen on the SmartVu control and verify the following:
 - a. The unit mode shows as emergency.
 - b. The indoor fan status shows “on”.
 - c. The status of all other components shows “off”.

d. If the unit did not respond to the test, press the test button again for 2 seconds. If the unit did not respond to the test, contact your service provider.

8. After the test is complete, reinstall the cover using the screws. Make sure the cover is properly secured to prevent air and water leaks.
9. To restore unit operation, press the login button and login with user access, then press the start/stop button and press “enable unit” button to enable unit operation.

Ultra-Violet Light System

CAUTION

PERSONAL INJURY

Disconnect UV light power prior to accessing unit interior. Note that the UV light power supply may be separate from the unit power supply.

Units with the UV-fixture option include UV fixtures installed after the indoor coil with interlocking door switches and a UV safe view port installed in the panel between the filter/indoor coil access door and indoor fan motor access door. Refer to Fig 2 for access door locations. Review access doors for UV warnings prior to opening UV doors or panels.

Periodically check the UV light operation through the UV safe view port to confirm UV light operation. Note that the UV light power may be separate from the main unit power. Refer to the UV emitter accessory installation instructions for details on replacing emitter bulbs.

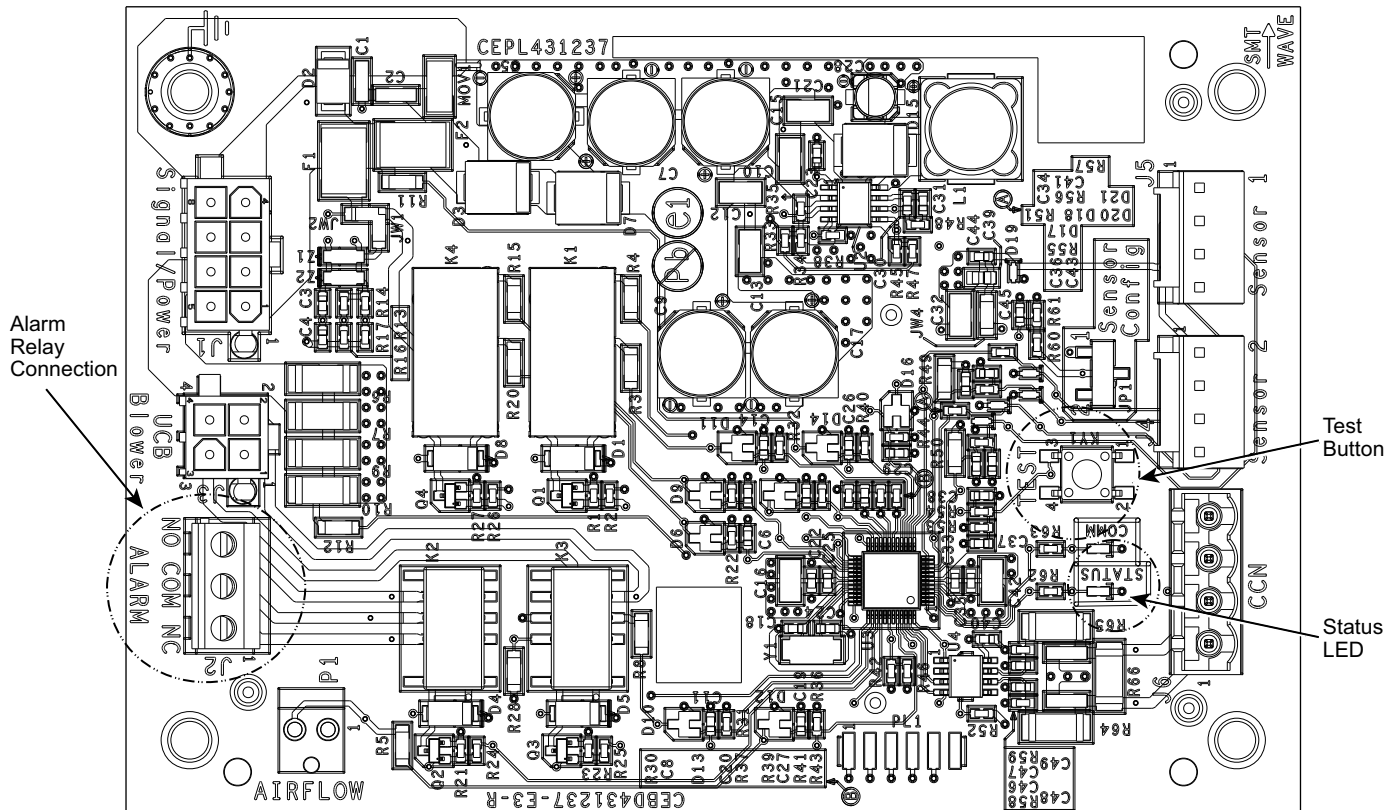

Fig. 19 — A2L Dissipation Board Details

