



Controls, Start-Up, Operation, and Troubleshooting

CONTENTS

	Page
SAFETY CONSIDERATIONS	2
GENERAL	2
Carrier Water Source Heat Pumps	2
Single-Zone (Space Temperature Control)	2
INSTALLATION AND START-UP	5
Local Access	5
Input/Output Wiring	5
• INPUTS	
• BINARY OUTPUTS	
• ANALOG OUTPUTS	
• WIRING INPUTS AND OUTPUTS	
Rnet Wiring	8
• WIRING DEVICES TO THE TRUVU CONTROLLER'S RNET PORT	
• WIRING ZS SENSORS TO THE CONTROLLER	
• WIRING THE EQ1-5 EQUIPMENT TOUCH INTERFACE TO THE TRUVU™ CONTROLLER	
Field-Installed Sensors and Accessories	10
• SUPPLY AIR TEMPERATURE SENSOR (SAT)	
• RETURN AIR TEMPERATURE SENSOR (RAT)	
• SPACE TEMPERATURE	
• RELATIVE HUMIDITY SENSOR (REQUIRED FOR DEUMDIFICATION OPERATION)	
• ZS COMMUNICATING SENSORS (RNET)	
• DISCRETE INPUTS	
Communication Wiring and Addressing Points and Properties	13
• SETPOINTS	
• ZS SENSOR BINDER	
SEQUENCE OF OPERATION	35
Scheduling	35
• OCCUPANCY	
• OCCUPANCY SOURCE - THE FOLLOWING SETTINGS DETERMINE OCCUPANCY.	
Fire/Smoke/Emergency Shutdown Input	35
Shutdown Input	35
Indoor Fan Operation	35
Automatic Fan Speed Control	35
Fan Speed Control	35
Fan Status	36
Cooling Operation	36
Heating Operation	36
Source Water Valve	36
Modulating Source Water Valve	37
2-Position Source Water Valve	37
Auxiliary Heat	37
• AUXILIARY MODULATING HOT WATER / SCR HEATING	
• STAGED ELECTRIC/HYDRONIC HEAT	
Indoor Air Quality (IAQ) and Demand Control Ventilation (DCV)	37
2-Position OA Damper	37
Dehumidification	37
Modulating Hot Gas Reheat	37
On/Off Hot Gas Reheat	37
Waterside Economizer	37
• COOLING	
• HEATING	
Demand Limiting	38
Power Failure Restart Delay	38
Alarms	38
• EMERGENCY SHUTDOWN (FIRE/SMOKE)	
• UNIT HARD LOCKOUT (UPM)	
• ZS SENSOR	
• ZS CONFIGURATION	
• SPACE TEMP SENSOR	
• CTRL TEMP SENSOR FAILURE	
• SPACE TEMPERATURE ALARMS	
• SOURCE WATER TEMPERATURE ALARM	
• SOURCE WATER DELTA TEMPERATURE ALARM	
• SUPPLY AIR TEMPERATURE ALARM	
• SUPPLY TEMPERATURE SENSOR FAILURE	
• RETURN AIR TEMPERATURE ALARM	
• RETURN TEMPERATURE SENSOR FAILURE	
• AIRSIDE DELTA TEMPERATURE ALARM	
• SECONDARY CONDENSATE OVERFLOW ALARM	
• PRIMARY CONDENSATE OVERFLOW ALARM (UPM)	
• SUPPLY FAN FAILURE	
• COMPRESSOR STATUS ALARM(S)	
• FILTER STATUS ALARM	
• INDOOR AIR QUALITY ALARM	
• CO ₂ SENSOR FAILURE	
• RELATIVE HUMIDITY ALARM	
• OUTDOOR AIR TEMPERATURE SENSOR ALARM	
• OA DAMPER ALARM	
• SOURCE WATER VALVE ALARM	
• WATER ECONOMIZER ALARM	
• LOW WATER FLOW ALARM	
• SOURCE WATER LINKAGE	
• INPUT CONFIGURATION	
• OUTPUT CONFIGURATION	
Zone Environmental Index	39
Initial Setup	46
Field Installed Options	46
Unconfigured/Replacement	46
APPENDIX A — BACNET POINTS LIST	40
APPENDIX B — WIRING DIAGRAMS	45
APPENDIX C — EQUIPMENT TOUCH NAVIGATION AND WIZARD	46

This document is to be used in conjunction with the following Carrier Corporation manuals:

- Equipment Touch Installation and Setup Guide
- ZS- sensor Installation Guide
- BACnet IP Integration Guide with TruVu Controller
- Field Assistant User Guide
- TruVu Compact Router (TV-CRB-E2) Installation and Start-up Guide

SAFETY CONSIDERATIONS

Installation and servicing of air-conditioning equipment can be hazardous due to system pressure and electrical components. Only trained and qualified service personnel should install, repair, or service air-conditioning equipment.

Untrained personnel can perform basic maintenance functions of cleaning coils and filters and replacing filters. All other operations should be performed by trained service personnel. When working on air-conditioning equipment, observe precautions in the literature, tags and labels attached to the unit, and other safety precautions that may apply.

Follow all local building codes and appropriate national electrical codes (in USA, ANSI/NFPA 70, National Electrical Code (NEC); in Canada, CSA C22.1) for special requirements. Wear safety glasses and work gloves. Use quenching cloth for unbrazing operations. Have fire extinguisher available for all brazing operations.

It is important to recognize safety information. This is the safety-alert symbol . When you see this symbol on the unit and in instructions or manuals, be alert to the potential for personal injury.

Understand the signal words DANGER, WARNING, CAUTION, and NOTE. These words are used with the safety-alert symbol. DANGER identifies the most serious hazards which **will** result in severe personal injury or death. WARNING signifies hazards which **could** result in personal injury or death. CAUTION is used to identify unsafe practices, which **may** result in minor personal injury or product and property damage. NOTE is used to highlight suggestions which **will** result in enhanced installation, reliability, or operation.

GENERAL

The TruVu™ WSHP controller is an integrated component of the Carrier Water Source Heat Pump (WSHP) unit. Its internal application programming is configured to operate the WSHP as a single-zone unit for space temperature control. The TruVu™ WSHP controller allows the unit to operate within the Carrier i-Vu® Open network, enabling water side linkage or as a standalone unit with monitoring/control from a third-party BACnet®¹ building automation system (BAS). Carrier's i-Vu user

interface Equipment Touch™ and the Field Assistant technician tool can be used with the TruVu™ WSHP controller. Access is available via the local access port or the Rnet communication network. See Fig. 1 for example of TV-WSHP controller. See Tables 1 and 2 for TV-WSHP specifications and input/output and configuration.

NOTE: The WSHP TruVu controller supports BACnet/IP only. For integration with an MS/TP system, the router (TV-CRB-E2) must be provided.

Carrier Water Source Heat Pumps

Carrier 50 Series WSHP units are indoor packaged heat pump products. 50 Series WSHP units are available in sizes 07-70 (single stage), sizes 24-70 (single compressor two-stage) and sizes 072-360 (two compressor, two stage). Each unit contains one or two compressors piped in independent refrigerant circuits. Each circuit includes a coaxial (tube-in-tube) water coil, TXV (thermostatic expansion valve), individual air coil, and all interconnecting piping. Available factory-installed options include Hot Gas Bypass, Hot Gas Reheat and Waterside Economizer (availability may be limited by unit model).

All 50 Series WSHP units include a unit protection module (UPM) which implements all the unit primary safeties. The TruVu™ WSHP interfaces with the UPM via Modbus communication and direct wiring. For details on the UPM sequence of operation see the WSHP equipment installation manual.

For complete details on Carrier WSHP units please refer to the latest product data and installation manuals.

Single-Zone (Space Temperature Control)

The TruVu™ WSHP provides either one or two stages of mechanical cooling and heat pump heating to maintain the zone air temperature setpoint, based on a control temperature input (typically a ZS sensor or RAT sensor). Optional functionality includes modulating or cycling hot gas reheat for dehumidification, modulating or cycling integrated water side economizer control, modulating or cycling electric heat, modulating or cycling hydronic heat, modulating or cycling source water valve, modulating outdoor air damper with demand controlled ventilation (DCV) operation, and auto fan speed control.

For complete details on the single-zone configuration functions See "Sequence of Operation" on page 35.

CAUTION

To protect against large electrical surges on serial EIA-485 networks, place a PROT485 at each place wire enters or exits the building.

1. Third-party trademarks and logos are the property of their respective owners.

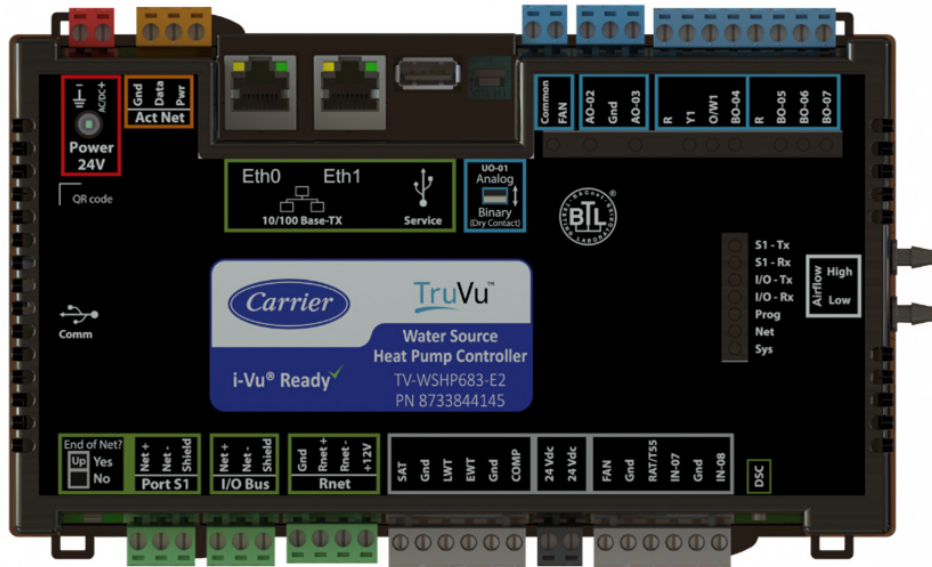

Fig. 1 – TV-WSHP

Table 1 – TV-WSHP Specifications

SPECIFICATIONS		
BACnet® Conformance	Conforms to the BACnet® Advanced Application Controller (B-AAC) and BACnet® Broadcast Management Device (B-BBMD) standard device profiles, as defined in BACnet® 135-2001 2012 Annex L Protocol Rev 14.	
Power	24 vac ± 15%, 50-60 Hz, 55VA, 24 vdc ± 10%, 20W (80VA / 35W if Act Net devices are connected).	
Communication	BAS Primary Port	Dual 10/100 BaseT Ethernet ports with built-in fail safe, supporting direct connection or daisy chain topology natively using BACnet/IP (non-routing).
	Serial Port 1	RS-485 port for communication with UPM (WSHP unit protection module) board .
	I/O Bus Port	Supports up to two TV-UCXP I/O expanders.
	Rnet Port	12 vdc @ 260 mA supports the following: Up to 5 ZS Sensors (freely mix ZS zone, ZS duct, ZS immersion, and ZS outdoor sensors), i-Vu® Equipment Touch, or TruVu ET Displays (external power required).
	Act Net Port	Supports up to 5 Act Net communicating devices such as the i-Vu Smart Valves and Smart Damper Kit.
	USB Service Port	For TruVu ET Display support configuration wireless service access firmware updates and controller recovery via USB drive TruVu ET Displays
	USB Expansion Port	For support of communication expansion devices (future).
Inputs	Universal	8 Universal Inputs configurable to any of the following: Dry Pulse Counting Thermistor 0-10 vdc
	Auxiliary Power	24 vdc @ 100 mA total current capacity
Integral Airflow Sensor	Precision differential pressure sensor 0-2 in. H ₂ O, sensitive down to ±0.001 in. H ₂ O. Barbed tapered airflow connections accept 3/16 in. (4.75 mm) I.D. tubing. Allows for readings across the 0-2in. H ₂ O range, accurate to ±5% of full flow at 2 in. H ₂ O	
Outputs	Universal Output	1 output selectable to 0-10 vdc (20 mA max), 12 vdc 80 Hz PWM, or (Dry Contact) Rated @ 24 vac 1 amp
	Analog Output	2 Analog Outputs 10 vdc @ 20 mA max (D/A Resolution 12 bits)
	Digital Output	6 digital outputs (Dry Contact) Rated @24 vac / vdc 1 amp. Configured normally open
Memory	4 GBs eMMC Flash Memory and 256 MB DDR3 DRAM. User data is archived to non-volatile flash memory when parameters are changed, every 90 seconds.	
Real Time Clock	Real-time clock keeps track of time in the event of a power failure for at least 3 days.	
Compliance	United States: FCC compliant to Title CFR47, Part 15, Subpart B, Class A; UL Listed, File E143900; CCN PAZX, UL 916, Energy Management Equipment; ANZ: RCM Mark AS/NZS 61000-6-3; Canada: UL Listed File E143900, CCN PAZX7, CAN/CSA C22.2 No. 205 Signal Equip., Industry Canada Compliant ICES-003, Class A; CE Mark Compliant with 2014/30/EU, and RoHS Compliant: 2015/863/EU; UKCA Mark compliant with Electromagnetic Compatibility Regulations 2016 – Gov.UK and RoHS for Electrical and Electronic Equipment 2012.	
Plastic Rating	Fire-Retardant Plastic ABS, UL94-5VA	
Environmental	Operating Range	-22 to 158°F (-30 to 70°C), 10-95% RH, Non-Condensing
	Storage	-40 to 158°F (-40 to 70°C), 10-95% RH, Non-Condensing

Table 2 – TV-WSHP I/O Configuration

INPUT/OUTPUT TYPE	TYPE OF I/O	I/O CHANNEL (CONNECTION PIN)	I/O CONFIGURATION
INPUTS			
Supply Air Temperature Sensor	10K Type II	IN-01	AI
Leaving Water Temperature Sensor	10K Type II	IN-02	AI
Entering Water Temperature Sensor	10K Type II	IN-03	AI
Compressor Status	Dry	IN-04	DI
Compressor Current	0-10 vdc		AI
Fan Status	Dry	IN-05	DI
Fan Current	0-10 vdc		AI
Return Air Temperature Sensor	10K Type II	IN-06	AI
Space Temperature Sensor			
Flow Switch, Emergency Shutdown, Remote Occupancy or Secondary Condensate Overflow	Dry	IN-07	DI
Water Flow Meter	0-10 vdc		AI
Flow Switch, Emergency Shutdown, Remote Occupancy or Secondary Condensate Overflow	Dry	IN-08	DI
Water Flow Meter	0-10 vdc		AI
OUTPUTS			
Fan Control (On-Off)	24 vac	UO-01	BO
Fan Control (Variable)	PWM or 0-10 vdc		AO
Multiple Applications (see Table 5)	0-10 vdc	AO-02	AO
Multiple Applications (see Table 5)	0-10 vdc	AO-03	AO
Compressor 1	24 vac	BO-02	BO
Reversing Valve	24 vac	BO-03	BO
Multiple Applications (see Table 5)	24 vac	BO-04	BO
Multiple Applications (see Table 5)	24 vac	BO-05	BO
Multiple Applications (see Table 5)	24 vac	BO-06	BO
Multiple Applications (see Table 5)	24 vac	BO-07	BO

INSTALLATION AND START-UP

Local Access

Use the following items as a local user interface to an Open controller. These items let you access the controller information, read sensor values, and test the controller. See Table 3 for local accesses. See Table 4 for input wiring specifications.

NOTE: These are accessory items that do not come with a controller.

Table 3 – Local Accesses

CONNECT...	TO THE CONTROLLER'S...	FOR:
Field Assistant Application ^a	Local Service Port	Temporary User Interface for Start-Up
Equipment Touch Interface ^b	Rnet Port	Temporary or Permanent User Interface for Start-Up
i-Vu [®] Application	BACnet [®] Network	Permanent Interface

NOTE(S):

- Requires a USB Link (part no. USB-L).
- See the Equipment Touch Installation and Setup Guide for detailed instructions.

⚠ CAUTION

If multiple controllers share power but polarity was not maintained when they were wired, the difference between the controller's ground and the computer's AC power ground could damage the USB Link and the controller. If you are not sure of the wiring polarity, use a USB isolator between the computer and the USB Link. Purchase a USB isolator online from a third-party manufacturer.

Input/Output Wiring

⚠ WARNING

Do not apply line voltage (mains voltage) to the controller's ports and terminals. Refer to Table 2 for terminal types and configuration.

Table 4 – Input Wiring Specifications

INPUT	MAX. LENGTH	MIN. GAUGE	SHIELDING
0-5 vdc 0-10 vdc	500 ft (152 m)	22 AWG	100 ft Unshielded 100-500 ft Shielded
0-20 mA	1000 ft (305 m)	22 AWG	100 ft Unshielded 100-500 ft Shielded
Thermistor Dry Contact Pulse Counter TLO	500 ft (152 m)	22 AWG	100 ft Unshielded 100-500 ft Shielded
RTD	100 ft (30 m)	22 AWG	Shielded
ZS Sensor Equipment Touch Interface TruVu [™] Display	See "WIRING DEVICES TO THE TRUVU CONTROLLER'S RNET PORT" on page 8.		

INPUTS

Refer to Table 2 for available inputs and associated configuration/type. See Table 5 for a description of the different input signal types.

Table 5 – Inputs

SIGNAL TYPE	DESCRIPTION
Thermistor	Precon type 2 (10 kOhm at 77°F). Input voltages should be from 0.489 vdc to 3.825 vdc for thermistors.
Dry Contact	A 5 vdc wetting voltage detects contact position, resulting in a 1 mA maximum sense current when the contacts are closed.
0-5 vdc 0-10 vdc	The input impedance of the TruVu controller is approximately 20 kOhm.
0-20 mA	The input resistance on the positive (+) terminal is 250 Ohms. The Aux Power Out connector is capable of supplying 24 vdc to multiple 4-20 mA transducers, but the total current demanded must not exceed 200 mA. If the voltage measured from the Aux Power Out connector to Gnd is less than 18 vdc, you need to use an external power supply.
RTD	<ul style="list-style-type: none"> Platinum: 1 kOhm at 32°F (0°C) Nickel/Iron: 1 kOhm at 70°F (21°C) Balco TS8000: 1 kOhm at 70°F (21°C) Input voltages should be from 0.6-1.2v

BINARY OUTPUTS

Each output is a dry contact that must be powered from a Class 2 power source. See Table 6 for available binary outputs.

To size output wiring, consider the following:

- Total loop distance from the power supply to the controller, and then to the controlled device.

NOTE: Include the total distance of actual wire. For 2-conductor wires, this is twice the cable length.
- Acceptable voltage drop in the wire from the controller to the controlled device.
- Resistance (Ohms) of the chosen wire gauge.
- Maximum current (amps) the controlled device requires to operate.

ANALOG OUTPUTS

See Table 6 for available analog outputs.

- AO-2 and AO-3 are configurable for 0-10 vdc only.
- Resistance to ground must be 500 ohms minimum.
- The device must share the same ground as the TruVu[™] Controller.

The TV-WSHP comes factory-wired for all standard features and selected factory-installed options. Factory wiring should not be altered in the field. The inputs and outputs available for field connection will vary by based on the unit model and selected options. See Table 6 for an overview of the available field installed inputs and outputs. Turn off power to the unit before making any connections to the TruVu module.

Table 6 – Available Field-Installed Outputs

MODEL	50WC	50WC, 50WD(07-12)	50WC, 50WD(15-18)	50WD(24-70), 50WT	50HQP/50VQP		WIRE LABEL
FAN MOTOR	PSC	CT ECM	CA ECM	CA ECM	VFD	1-Speed	
I/O POINT	FACTORY WIRED POINTS						
UO-1	G1	G1	PWM	PWM	VFD-S	G1	G1
AO-2	N/A	N/A	N/A	MHGRH ^a	N/A	N/A	MHGRH / AO2
AO-3	N/A	N/A	N/A	N/A	N/A	N/A	AO3
BO-2	Y1	Y1	Y1	Y1	Y1	Y1	Y1
BO-3	O	O	O	O	O	O	O
BO-4	WSE ^a	WSE ^a	WSE ^a	Y2	Y2	Y2	Y2
BO-5	HGRH ^a / W1 ^a	HGRH ^a / W1 ^a	HGRH ^a / W1 ^a	HGRH ^a / W1 ^a	HGRH ^a	HGRH ^a	Y2 / WSE / BO4
BO-6	N/A	G2	N/A	WSE ^a	WSE ^a	WSE ^a	HGRH / W1 / BO5
BO-7	N/A	G3	N/A	N/A	VFD-E	N/A	G2 / WSE / BO6
FIELD WIRED POINTS ^b							
AO-2	Aux HT, MWSE, MOAD, MWV						MHGRH/AO2
AO-3	Aux HT, MWSE, MOAD, MWV						AO3
BO-3	W1 ^c						O
BO-4	W1, W2			N/A	N/A	N/A	Y2
BO-5	WSE, W1, W2, FS, CS						Y2 / WSE / BO4
BO-6	WSE, W1, W2, FS, CS, WV	N/A	WSE, W1, W2, FS, CS, WV				HGRH / W1 / BO5
BO-7	WSE, W1, W2, FS, CS, WV	N/A	WSE, W1, W2, FS, CS, WV		N/A	WSE, W1, W2, FS, CS, WV	G2/WSE/BO6

NOTE(S):

- a. Available as factory-installed option, may not be used.
- b. Not available if output is used for factory-installed option.
- c. Available only for electric heat when units are configured for cooling-only operation.

LEGEND

- N/A** — Not Used or Not Available
- Aux HT** — Modulating External Heating Device Output
- CS** — Compressor Status Output
- FS** — Fan Status Output
- G1** — First Speed Fan Output, Low if Multi-Speed
- G2** — Medium Speed Fan Output
- G3** — High Speed Fan Output
- HGRH** — Hot Gas Reheat Output
- MHGRH** — Modulating Outside Air Damper Output
- MWSE** — Modulating Waterside Economizer Valve Output
- MWV** — Modulating Source Water Valve Output
- O** — Reversing Valve Output
- PWM** — Pulse Width Modulation Blower Motor Output
- VFD-E** — VFD Enable Output
- VFD-S** — 0-10 Vdc VFD Speed Output
- W1** — Second Stage Hydronic/Electric Heat Output
- W2** — Second Stage Hydronic/Electric Heat Output
- WSE** — On/Off Waterside Economizer Output
- WV** — Open/Close Source Water Valve
- Y1** — First Stage Compression Output
- Y2** — Second Stage Compression Output

WIRING INPUTS AND OUTPUTS

1. Turn off the TruVu™ controller's power.
2. Connect the input wiring to the screw terminals on the TruVu controller as shown in Fig. 2.
 - a. If using shielded wire, connect the shield to the GND terminal with the ground wire. Tape off the shield wire at the sensor end.
 - b. Connect the shield wire to the GND terminal with the ground wire.
 - c. For an internally powered 4-20 mA sensor, wire the sensor's positive terminal to the + terminal on the TruVu controller's AUX POWER OUT port. Wire the sensor's negative terminal to an input's + terminal.
3. Connect the binary output wiring to the screw terminals on the TruVu™ and to the controlled device as shown in Fig. 3.
4. Connect the analog output wiring to the screw terminals on the TruVu™ and to the controlled device as shown in Fig. 4.
5. Turn on the TruVu™ controller's power.

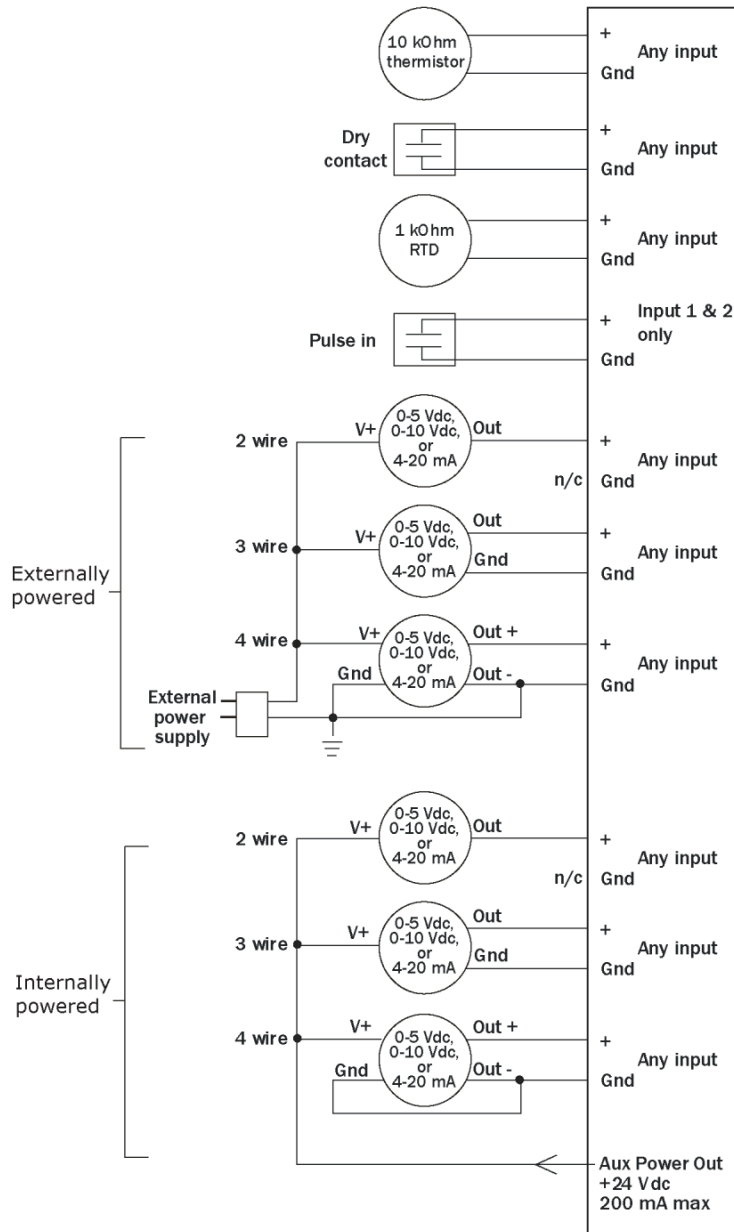

Fig. 2 — TruVu™ Typical Wiring

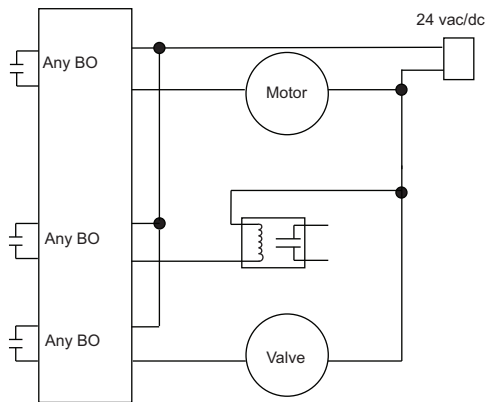

Fig. 3 — Connect Binary Output Wiring Screw Terminals

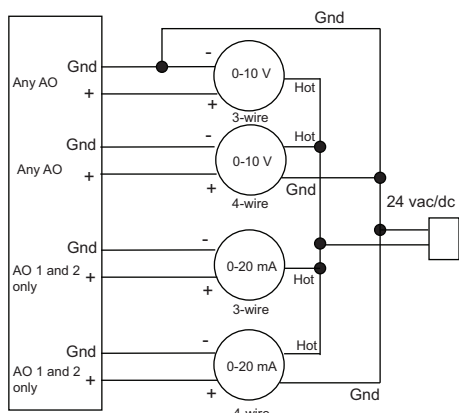

Fig. 4 — Connect Analog Output Wiring to Screw Terminals

Rnet Wiring

WIRING DEVICES TO THE TRUVU CONTROLLER'S RNET PORT

The Rnet communicates at a rate of 115 kbps and should be wired in a daisy-chain configuration. See Table 8 for Rnet wiring specifications.

This configuration supports up to:

- 15 wireless and/or ZS sensors (5 per control program)
- One Equipment Touch interface
- One TruVu™ ET display

NOTE: ZS sensors, a Wireless Adapter, and an Equipment Touch interface can share the Rnet, but not SPT sensors. The Wireless Adapter, Equipment Touch, or TruVu™ ET display must be powered by an external power source.

WIRING ZS SENSORS TO THE CONTROLLER

ZS sensors are thermistor-based temperature sensors that may optionally sense humidity, CO₂, or VOC (volatile organic compounds). ZS sensors are wired to the Rnet port on i-Vu® Open controllers. You can use the following ZS sensors:

- ZS Standard
- ZS Plus
- ZS Pro
- ZS Pro-F

NOTE: The ZS CO₂ model uses 190 mA during sample period. Use auxiliary 12 vdc, unless it is the only device on the Rnet port. A control program can use no more than 5 ZS sensors. SPT sensors cannot share the Rnet with other devices. For detailed instructions, see the ZS Sensor Installation Guide.

Follow Steps 1-4 for wiring the ZS Sensor to the controller:

1. Remove power from the TruVu™ controller.
2. Partially cut, then bend and pull off the outer jacket of the Rnet cable(s). Do not nick the inner insulation. Strip about .25 in. (0.6 cm) of the inner insulation from each wire. See Fig. 5 sensor cable configuration example.
NOTE: Carrier recommends using the Rnet wiring scheme in Table 7.
3. Wire each terminal on the sensor to the same terminal on the controller. See Table 8 for Rnet wiring requirements.
4. Apply power to the TruVu™ controller.

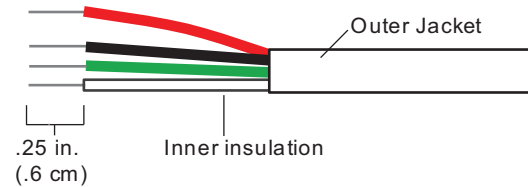

Fig. 5 — Installing ZS Sensor Cables

Table 7 — Rnet Wiring Scheme

Connect this wire...	To this terminal...
Red	+12v
Black	Rnet-
White	Rnet+
Green	Gnd

Table 8 — Rnet Wiring Specifications^a

WIRE/CABLE TYPE	SPECIFICATIONS	DESCRIPTION
4 Conductor Shielded Or Unshielded CMP Plenum Rated Cable	Conductor	22 AWG (7x0096) bare copper if Rnet has only sensors
	Maximum length	500 ft (152 m)
	Insulation	Low-smoke PVC (or equivalent)
	Color Code	Black, white, green, red
	Shielding	If shielded, Aluminum/Mylar ^{®b} shield (100% coverage) with TC drain wire, terminated at controller
	UL Temperature Rating	32-167°F (0-75°C)
	Voltage	300 vac, power limited
	Listing	UL:NEC CL2P, or better

NOTE(S):

- a. Use the specified type of wire and cable for maximum signal integrity.
- b. Third-party trademarks and logos are the property of their respective owners.

- CMP** — Communications Multipurpose Cable Plenum
- AWG** — American Wire Gauge
- PVC** — Polyvinyl Chloride
- TC** — Tinned Copper Wire

WIRING THE EQT1-5 EQUIPMENT TOUCH INTERFACE TO THE TRUVU™ CONTROLLER

The Equipment Touch interface requires a 24 vac power supply. It is not powered by the Rnet.

If the Equipment Touch interface will be:

- Daisy-chained on the Rnet with ZS sensors or a Wireless Adapter, use the standard 4-conductor Rnet wiring and follow the wiring instructions “WIRING ZS SENSORS TO THE CONTROLLER” on page 8.
- The only device on the Rnet, you can use a 2-conductor cable instead of the standard 4-conductor Rnet cable and follow the instructions below.

For complete Equipment Touch installation instructions including wiring diagrams, see the Equipment Touch Installation and Setup Guide.

Complete Steps 1-11:

IMPORTANT: The Equipment Touch controller can share a power supply with the TruVu™ controller as long as:

- The power supply is AC power.
- You maintain the same polarity.
- You use the power source only for Carrier controllers.

1. Turn off the TruVu™ controller’s power.
2. Remove the backplate from the Equipment Touch controller. While firmly pressing the 2 tabs on top of the Equipment Touch interface, pull on the backplate with your index finger until the backplate releases from the Equipment Touch interface.
3. Pull the power and communication wiring through the hole in the center of the backplate.
4. If wiring 1 cable to the Equipment Touch controller, cut the shield wire off at the outer jacket, then wrap the cable with tape at the outer jacket to cover the end of the shield wire. If wiring 2 cables in a daisy-chain configuration, twist together the shield wires, then wrap the shield wires with tape.
5. Strip about 0.25 in. (0.6 cm) insulation from the end of each wire. Refer to Fig. 5 for cable dimensions.

⚠ CAUTION

Allow no more than 0.06 in. (1.5 mm) bare communication wire to protrude. If bare communication wire contacts the cable’s foil shield, shield wire, or a metal surface other than the terminal block, the device may not communicate correctly.

6. Connect wiring to the Equipment Touch controller as shown in Fig. 6.
7. If mounting in or on a panel, attach the backplate to the wall or panel:
 - a. Drill two 3/16 in. (4.8 mm) pilot holes in the panel.
 - b. Attach backplate using pan head 6-32 x 3/8 in. to 1/2 in. long machine screws. Do not overtighten screws to prevent damage to plastic housing.
 - c. RECOMMENDATION: Use Loctite® 220 on screw threads if the Equipment Touch controller will be subject to vibration.
8. Attach the Equipment Touch interface to the backplate:
 - a. Place the bottom of the Equipment Touch interface onto the backplate by aligning the 2 slots on the Equipment Touch interface with the tabs on the backplate.
 - b. Push the Equipment Touch interface onto the backplate until the tabs at the top of the Equipment Touch interface snap onto the backplate.

⚠ CAUTION

Be careful to avoid bending the connecting pins when attaching the Equipment Touch onto the backplate.

9. Connect power wiring to a 24 vac or 12–24 vdc power supply.
10. Turn on the TruVu™ controller’s power.
11. Turn on the Equipment Touch interface.

1. Third-party trademarks and logos are the property of their respective owners.

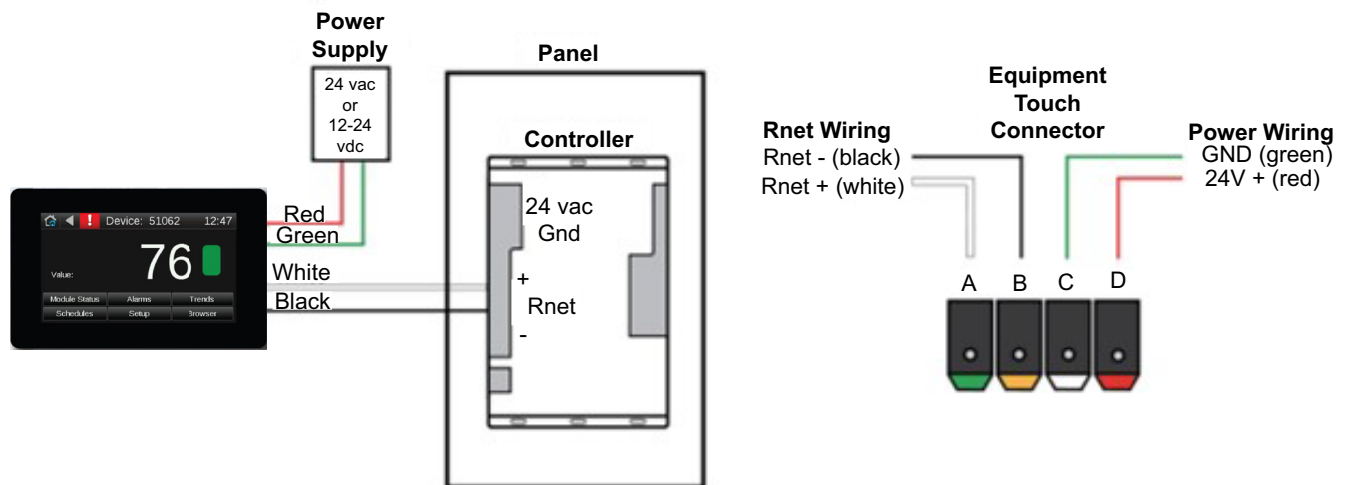

Fig. 6 — Wiring Equipment Touch Interface to TruVu™ Controller

Field-Installed Sensors and Accessories

See Table 9 for a summary of the factory and field-supplied sensors for units ordered with the TV-WSHP controller.

SUPPLY AIR TEMPERATURE SENSOR (SAT)

Units ordered with the TV-WSHP controller ship with a factory-installed supply air temperature sensor located inside the unit cabinet. This sensor must be field installed in the discharge ductwork. If a field installed accessory duct heater is installed this sensor must be mounted downstream of the heater.

Sensor Mounting

1. Place the sensor in the middle of the duct away from temperature stratified air, coils or humidifiers to achieve the best temperature reading. See Fig. 7 for sensor schematic example.
2. Drill the probe hole as depicted in Fig. 8 for the enclosure being used. Insert the probe into the duct.

3. Mount the enclosure to the duct using No. 8 screws through a minimum of two opposing mounting tabs.

NOTE: Weatherproof enclosures require assembly of the mounting tabs on opposite corners. A 1/8 in. pilot screw hole in the duct makes mounting easier through the mounting tabs. Use the enclosure tabs to mark the pilot hole locations.

4. Snug up the sensors so that the foam backing is depressed to prevent air leakage but do not over-tighten or strip the screw threads.

RETURN AIR TEMPERATURE SENSOR (RAT)

Units ordered with the TV-WSHP controller ship with a factory-installed return air temperature sensor located inside the unit cabinet. This sensor must be field-installed in the return ductwork upstream of any heating or cooling coil, including the optional water-side economizer if installed.

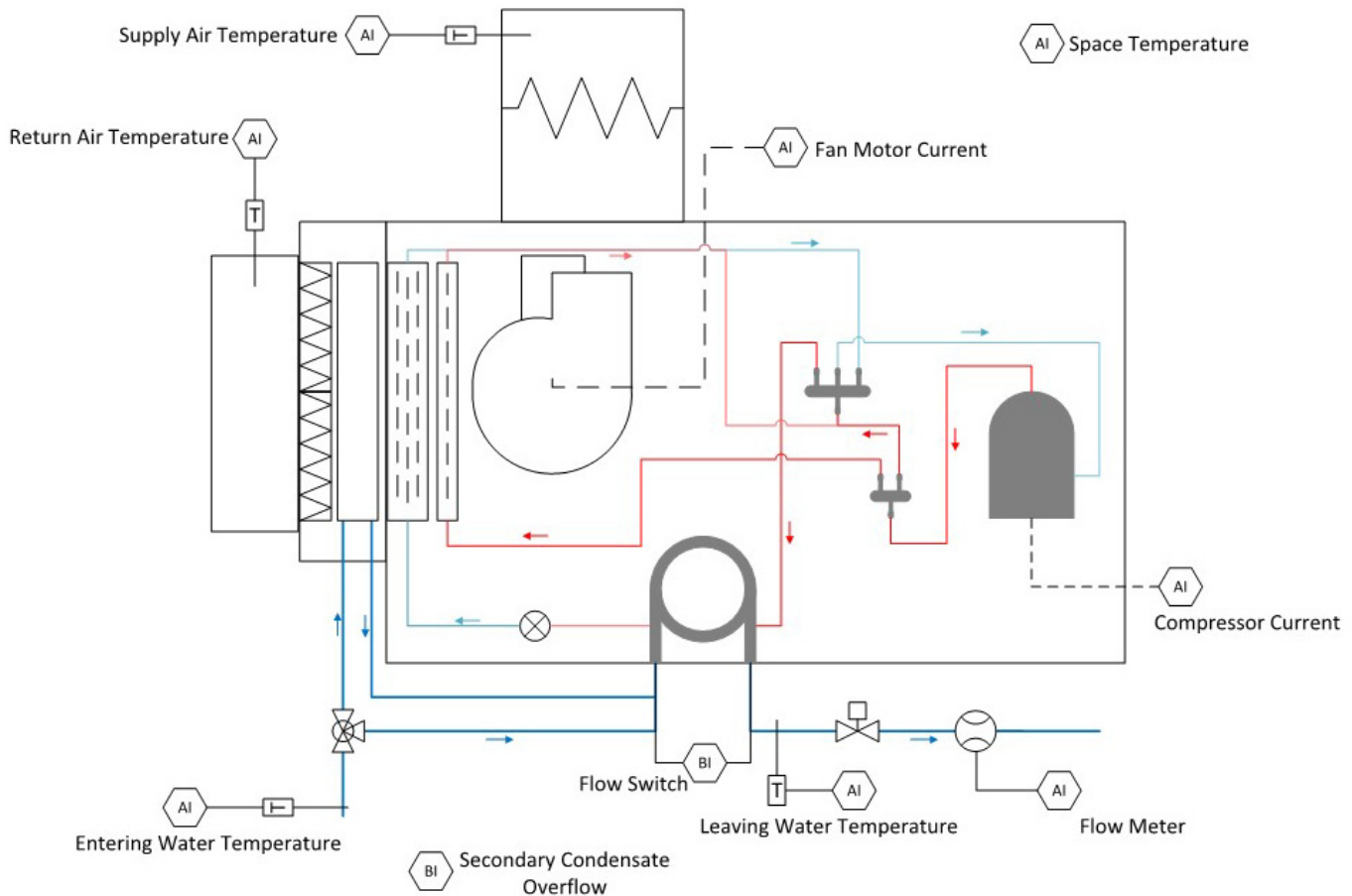

Fig. 7 — Sensor Schematic

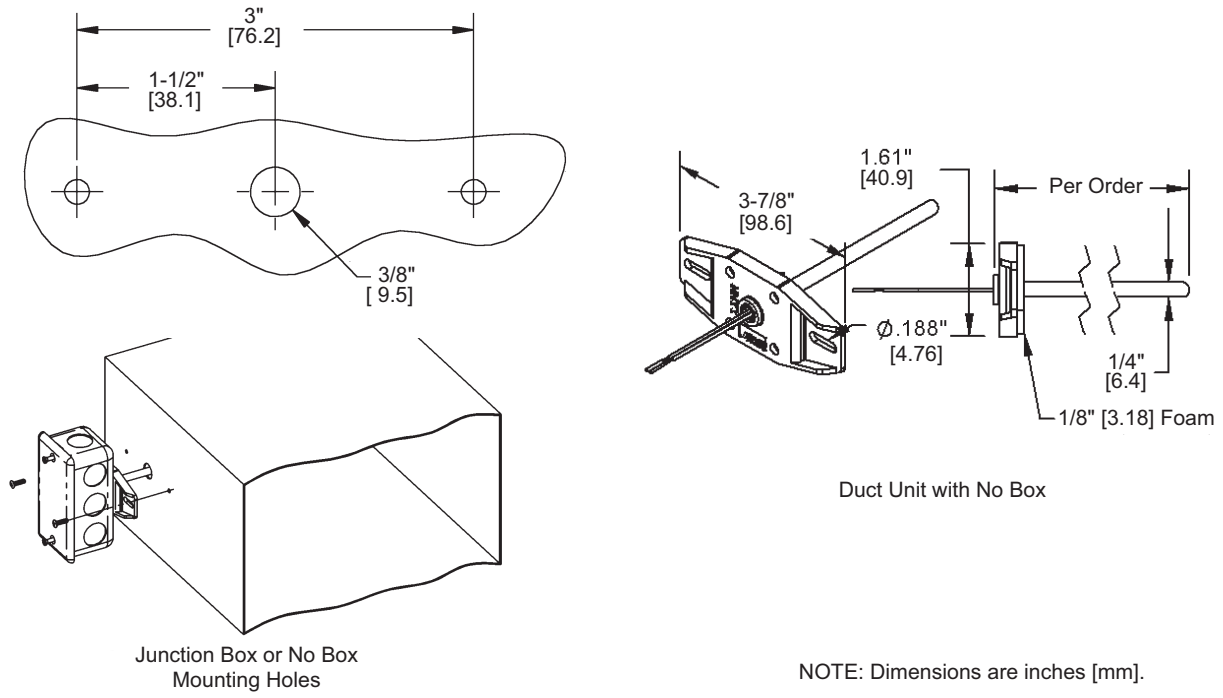

Fig. 8 – Sensor Schematic Mounting to Duct

SPACE TEMPERATURE

For single-zone space temperature control a control temperature input is required. The control temperature can be either a space temperature input or a local return air temperature input. The controller can receive the space temperature via a ZS sensor wired to the Rnet port (preferred) or over the network.

RELATIVE HUMIDITY SENSOR (REQUIRED FOR DEUMIDIFICATION OPERATION)

A space mounted relative humidity sensor can be used to monitor the relative humidity of the conditioned space. This is required for HGRH (hot gas reheat) dehumidification operation available for single-zone space temperature control applications. The controller source for relative humidity can be a ZS sensor wired to the RNET port or the network. Refer to “Input/Output Wiring” on page 5 for wiring specifications and Table 9 for available Carrier relative humidity sensors.

ZS COMMUNICATING SENSORS (RNET)

The Rnet bus allows local communication with the TruVu™ controller, including communicating sensors. The Rnet bus can support zone temperature and relative humidity. A variety of ZS sensors supporting any one or a combination of these values are available for use with the TruVu™ controller. A maximum of five ZS sensors can be used on a single controller.

DISCRETE INPUTS

The following discrete inputs are provided for use with optional field-installed accessories. Each input is configurable to be normally open (NO) or normally closed (NC):

- compressor status (NO only)
- fan status (NO only)
- flow switch
- emergency shutdown
- remote occupancy
- secondary condensate overflow

Table 9 – Sensor Summary

DESCRIPTION	QTY	SHIPPING LOCATION	INSTALLATION LOCATION	PART NUMBER
Supply Air Temperature Sensor	1	Installed	Blower Housing	8-733-815-707
Supply Air Temperature Sensor (required for VAV operation)	1	Loose for Field Installation	Supply Air Stream	T-111-641-258
Return Air Temperature Sensor	4	Loose for Field Installation	Return Air Stream	T-111-641-258
Entering Water Temperature	1	Installed	Source Entering Water	8-733-815-707
Leaving Water Temperature	1	Installed	Source Leaving Water	8-733-815-707
Duct Static Pressure Sensor	1	Loose for Field Installation	Supply Air Stream	8-733-940-957
Compressor Current Transducer	1 per comp.	Installed	Unit Electrical Box	8-733-941-336
Relative Humidity Sensor (optional, required for dehumidification)	1	Field-Supplied	Space or Return Air Stream	ZS, 33ZCSENSRH-02, 33ZCSENDRH-02
CO ₂ Sensor (optional, required for DCV operation)	1	Field-Supplied	Space or Return Air Stream	ZS, 33ZCSPTCO2-01
Flow Switch	1	ETO to Factory Install Differential Pressure Switch / Field-Supplied	Across Water Entering and Leaving / NA	T-111-641-192 / NA

Communication Wiring and Addressing Points and Properties

See Fig. 9 for a navigation outline of the Field Assistant property settings. See Tables 10-24 on pages 16-31 For descriptions of all possible settings for the controller on the i-Vu® or Field Assistant Properties tab.

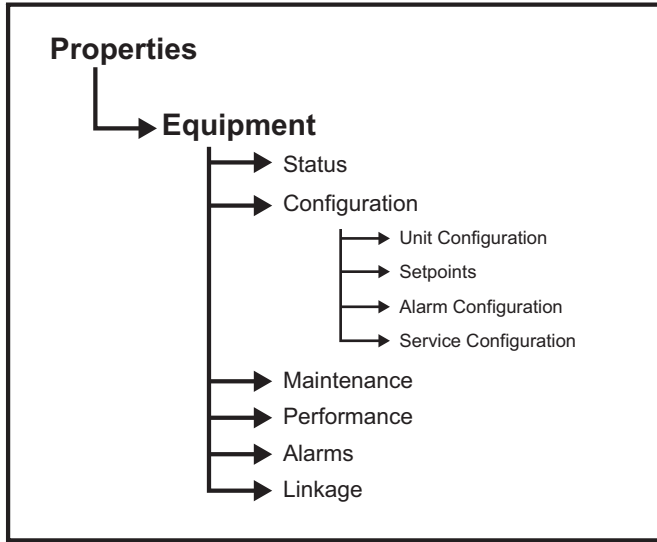

Fig. 9 — Field Assistance Navigation Chart

SETPOINTS

To change setpoints select a color band on the setpoint graph to see the current setpoints in the Heating and Cooling fields. See Fig. 10 for heating and cooling setpoints.

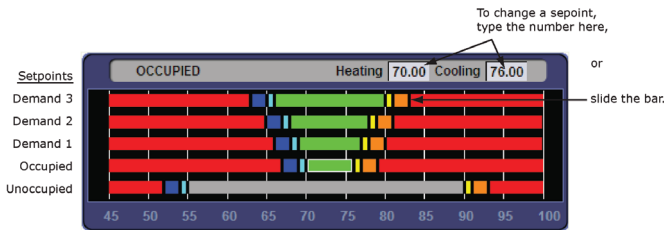

Fig. 10 — Heating and Cooling Setpoints

Occupied Setpoints

The occupied setpoints described in Table 18 on page 26 are the setpoints under normal operating conditions. Demand Level 1-3 setpoints apply if demand limiting is used.

Demand limiting is a cost-saving strategy to reduce energy consumption. The strategy expands the occupied heating and cooling setpoints when the system reaches 1 of 3 levels of consumption. With the expanded setpoints, the equipment works less, thereby saving energy. By default, Demand Level 1 expands the occupied heating and cooling setpoints by 1°F, Demand Level 2 by 2°F, and Demand Level 3 by 4°F. If the occupied heating or cooling setpoints change, the (effective) demand level setpoints automatically change by the same amount. See “Sequence of Operation” on page 35-39 for more information.

Unoccupied Setpoints

The occupied setpoints described in Table 18 are the setpoints under normal operating conditions in the unoccupied state.

Mode Transition Hysteresis

The Hysteresis example in Fig. 11 shows the zone color that results as the space temperature departs from and returns to the acceptable range in a zone with the following settings:

- Color Change Hysteresis = 0.5°F (0.27°C) (applies as the temperature returns to the acceptable range)
- Occupied Cooling Setpoint = 76°F (24.4°C)
- Occupied Heating Setpoint = 70°F (21.1°C)

See Table 19 on page 27 for the unoccupied setpoints under normal operating conditions.

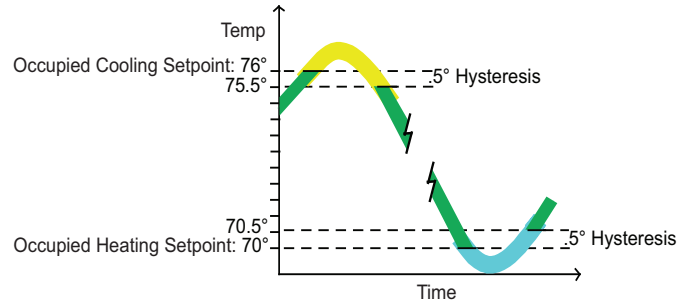

NOTE: Values are in degrees Fahrenheit.

Fig. 11 — Hysteresis Example

Learning Adaptive Optimal Start

When the learning adaptive optimal start algorithm runs, the learned heating capacity or learned cooling capacity values are adjusted based on the color that is achieved when occupancy begins. The adjustment amounts for each color are displayed in the thermographic color fields (with English default values). See Table 20 on page 27 for more details on learning adaptive algorithms. See Fig. 12 for learning adaptive amounts.

Red	DkBlue	LtBlue	Green or SpGrn	Yellow	Orange	Red
0.1900	0.1300	0.0600	0.0600	0.0600	0.1300	0.1900

Fig. 12 — Learning Adaptive Adjustment Amounts

Effective Setpoints

The effective setpoints graph shows the current occupied or unoccupied setpoints. If occupied, these values are the current programmed setpoints plus the offset of any setpoint adjustment that may be in effect. If unoccupied, the values are the programmed unoccupied setpoints. See Fig. 13 for effective setpoints.

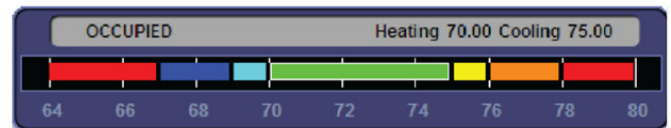

NOTE: Values are in degrees Fahrenheit.

Fig. 13 — Effective Setpoints

ZS Sensor Setpoints

To configure setpoint properties for ZS sensors, Ctrl + click anywhere on the Zone Setpoints graph (at the top of the Setpoints section in order to access the Properties popup). See Fig. 14 for example of zone setpoints and Table 22 on page 28 for more information on ZS sensor setpoints.

In the popup, on the (*Properties* → *Sensor*) tab, configure ZS sensors for Setpoint Adjust. See Fig. 15 for information on adjusting setpoints and Table 21 for information on effective setpoints.

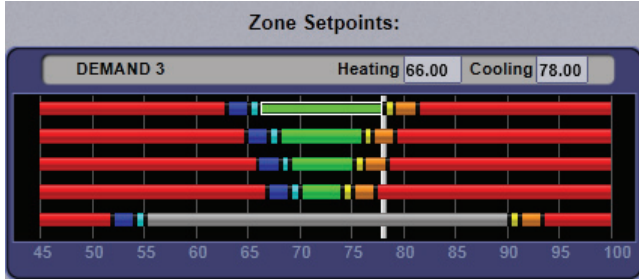

Fig. 14 – Zone Setpoints

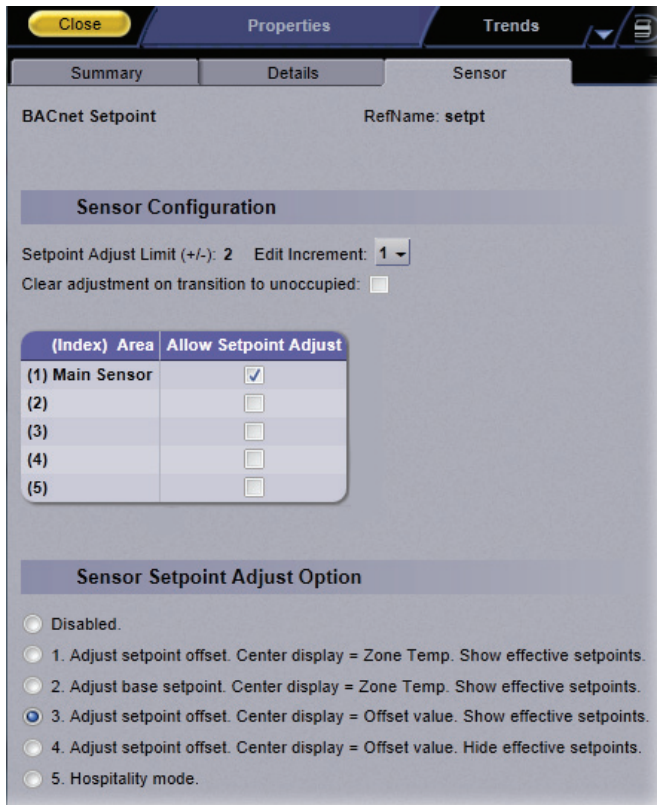

Fig. 15 – Adjusting Setpoints

ZS SENSOR BINDER

Ctrl+click on the name of these properties to access the popup (*Properties page* → *Details*) tab. See Fig. 16 for a sensor binder example.

Sensor Binder

Use Table 9 on page 12 to configure the Rnet to use additional ZS sensors.

Network Type: Set to Rnet.

Address: Enter the DIP switch settings that are on the additional ZS sensors (up to 5 total).

Lock Display: Check to make the sensor display-only.

Index	Area	Network Type	Address	Lock Display	Version	Status	Error
1	Main Sensor	Rnet	1	<input type="checkbox"/>		Sensor Offline	No Comm
2	Sensor 2	Unused	2	<input type="checkbox"/>		Sensor Offline	None
3	Sensor 3	Unused	3	<input type="checkbox"/>		Sensor Offline	None
4	Sensor 4	Unused	4	<input type="checkbox"/>		Sensor Offline	None
5	Sensor 5	Unused	5	<input type="checkbox"/>		Sensor Offline	None

Fig. 16 – Sensor Binder Example

Zone Temp

Configure additional ZS sensors used on the 50BV unit. See Fig. 17 for a zone temperature configuration example.

Use: Check to include ZS sensor's value in the Combined Algorithm (**Average** is default).

Raw Value: Displays sensed temperature for each ZS sensor's address.

Calibration: If needed, enter value to adjust the **Corrected Value** from the **Raw Value**, in order to calibrate an individual ZS sensor's sensed value.

Combination Algorithm: Use **Average**, **Maximum**, or **Minimum** zone temperature to calculate the **Corrected Value** for temperature control.

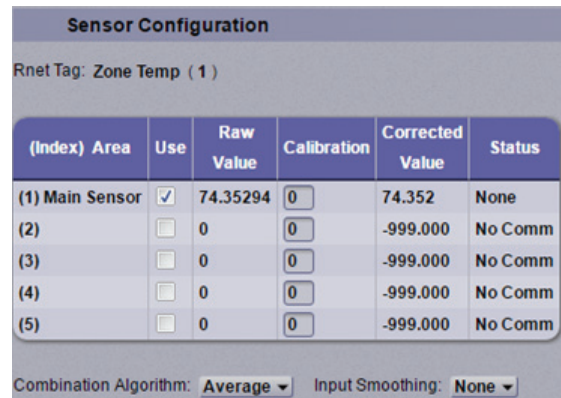

Fig. 17 – Zone Temperature Example

Zone Humidity

Configure additional ZS or wireless humidity sensors used on the Tru-VU WSHP unit. See Fig. 18 for a zone humidity configuration example.

Use: Check to include ZS sensor’s value in the Combined Algorithm (**Average** is default).

Raw Value: Displays sensed temperature for each ZS sensor’s address.

Calibration: If needed, enter value to adjust the **Corrected Value** from the Raw Value, in order to calibrate an individual ZS sensor’s value.

Combination Algorithm: Use **Average**, **Maximum**, or **Minimum** zone temperature to calculate the **Corrected Value** for temperature control.

(Index) Area	Use	Raw Value	Calibration	Corrected Value	Status
(1) Main Sensor	<input checked="" type="checkbox"/>	32.772625	0	32.772	None
(2)	<input type="checkbox"/>	0	0	-999.000	No Comm
(3)	<input type="checkbox"/>	0	0	-999.000	No Comm
(4)	<input type="checkbox"/>	0	0	-999.000	No Comm
(5)	<input type="checkbox"/>	0	0	-999.000	No Comm

Combination Algorithm: **Maximum** Input Smoothing: **Medium**

Fig. 18 – Zone Humidity Example

ZS Zone CO₂

Configure additional ZS CO₂ sensors used on the TruVu WSHP unit. See Fig. 19 for sensor configuration.

Use: Check to include ZS sensor’s value in the **Combined Algorithm** (**Maximum** is default).

Raw Value: Displays sensed CO₂ for each ZS CO₂ sensor’s address.

Calibration: If needed, enter value to adjust the **Corrected Value** from the **Raw Value**, in order to calibrate an individual ZS sensor’s sensed value.

Combination Algorithm: Use **Average**, **Maximum**, or **Minimum** ZS CO₂ to calculate the **Corrected Value** for CO₂ control.

(Index) Area	Use	Raw Value	Calibration	Corrected Value	Status
(1) Main ZS Sensor	<input type="checkbox"/>	0	0	-999.000	Unsupported Read
(2)	<input type="checkbox"/>	0	0	-999.000	No Comm
(3)	<input type="checkbox"/>	0	0	-999.000	No Comm
(4)	<input type="checkbox"/>	0	0	-999.000	No Comm
(5)	<input type="checkbox"/>	0	0	-999.000	No Comm

Combination Algorithm: **Maximum** Input Smoothing: **Medium**

Fig. 19 – ZS Zone CO₂ Example

Table 10 – Alarms

POINT NAME/DESCRIPTION	RANGE
<i>i-Vu® / Field Assistant Navigation: Properties → Control Program → Alarms</i>	
Emergency Shutdown – Indicates if the unit is in a Fire / Smoke / Emergency Shutdown condition.	Normal / Alarm
Unit Hard Lockout – Indicates if the unit is in a Hard Lockout condition from the UPM board.	Normal / Alarm
Space Temperature – Indicates if the space temperature sensor exceeds the high or low alarm limit.	Normal / Alarm
Alarming Temperature – The value of the alarming space temperature sensor. Visible only in an alarm condition.	–60 to 250°F
Alarm Limit Exceeded – The alarm limit that the alarming space temperature sensor exceeded. Visible only in an alarm condition.	–60 to 250°F
ZS Temp Sensor – Indicates if the ZS communicating zone temperature sensor is no longer communicating.	Normal / Alarm
Space Temp Sensor – Indicates if the space temperature sensor is no longer communicating.	Normal / Alarm
CTRL Temp Sensor – Indicates if the controlling temperature sensor is no longer communicating.	Normal / Alarm
ZS Sensor Configuration – Indicates that at least 1 ZS sensor is configured in the Sensor Binder properties and is not communicating.	Normal / Alarm
Supply Fan Failure – Indicates an alarm condition if the supply fan's status fails to match the fan's commanded state when ON. Only for units with a status or amperage feedback.	Normal / Alarm
Indoor Air Quality – Indicates if the occupied CO ₂ level exceeds the Occupied High CO₂ Alarm Limit .	Normal / Alarm
Compressor 1 Status – Indicates an alarm condition if compressor 1 status fails to match the commanded state when ON. Only for units with a status or amperage feedback.	Normal / Alarm
Compressor 2 Status – Indicates an alarm condition if compressor 2 status fails to match the commanded state when ON. Only for units with a status or amperage feedback.	Normal / Alarm
Low Water Flow – Indicates water flow not sufficient to enable compressor(s) or utilize water economizer.	Normal / Alarm
Supply Air Temperature Alarm – Indicates that the supply air temperature is outside the configured alarm limits.	Normal / Alarm
Supply Temp Sensor Failure – Indicates a shorted or open circuit in the SAT input.	Normal / Alarm
Return Air Temperature Alarm – Indicates that the return air temperature is outside the configured alarm limits.	Normal / Alarm
Return Temp Sensor Failure – Indicates a shorted or open circuit in the RAT input.	Normal / Alarm
Secondary Condensate Overflow – Indicates the Secondary Condensate Overflow Switch has detected water.	Normal / Alarm
Primary Condensate Overflow (UPM) – Indicates the Primary Condensate Overflow Switch has detected water. NOTE: The data is provided by the UPM board.	Normal / Alarm
CO₂ Sensor Failure – Indicates a shorted or open circuit in the CO ₂ input.	Normal / Alarm
Cooling Source Water Temperature – Indicates if the source water temperature exceeds the Min/Max Source Temp Cooling values.	Normal / Alarm
Heating Source Water Temperature – Indicates if the source water temperature exceeds the Min/Max Source Temp Heating values.	Normal / Alarm
Filter – Indicates a dirty filter condition when the filter runtime exceeds the value of the Filter Service Alarm Timer .	Clean / Dirty
Space Relative Humidity – Indicates if the relative humidity exceeds the high RH alarm limit.	Normal / Alarm
Src Water Valve Alarm – The differential is the absolute value of the commanded position of the source water valve minus the feedback position has exceed the Src Water Valve Alarm Diff (ACT Net only).	Normal / Alarm
OA Damper Alarm – The differential is the absolute value of the commanded position of the OA damper minus the feedback position has exceed the OA Damper Alarm Diff (ACT Net only).	Normal / Alarm
Water Economizer Alarm – The differential is the absolute value of the commanded position of the water economizer minus the feedback position has exceed the Water Economizer Alarm Diff (ACT Net only).	Normal / Alarm
Input Configuration – Indicates if one or more of the inputs are configured for the same function.	Normal / Alarm
Output Configuration – Indicates if one or more of the outputs are configured for the same type of function.	Normal / Alarm
Outdoor Air Temp Sensor – Indicates if the controller is no longer receiving a valid outdoor air temperature value either through the network or waterside linkage.	Normal / Alarm
Source Water Linkage – Indicates if Source Water Linkage has failed.	Normal / Alarm

Table 11 – Alarm Configuration

POINT NAME/DESCRIPTION	DEFAULT	RANGE
<i>i-Vu® / Field Assistant Navigation: Properties → Control Program → Configuration → Alarm Configuration</i>		
SPACE TEMPERATURE ALARM		
Occupied Alarm Hysteresis – This value is added to the occupied high effective setpoint and subtracted from the occupied low effective setpoint to establish the occupied high and low limits that the space temperature must exceed before an occupied SPT alarm is generated. The alarm returns to normal when the space temperature drops below the high effective setpoint or rises above the low effective setpoint.	5°F	2 to 20°F
Alarm Delay (min/deg) – Determines the amount of delay before an occupied space temperature alarm is generated when the controller transitions to the occupied mode. The delay time equals this value multiplied by the difference between the sensor temperature and occupied alarm setpoint plus 15 minutes.	10 min.	0 to 30 min.
Unoccupied Low SPT Alarm Limit – The value that the space temperature must drop below to generate a Space Temperature Alarm in the unoccupied mode. There is a fixed hysteresis of 1°F (0.5 °C) for return to normal.	45°F	15 to 90°F
Unoccupied High SPT Alarm Limit – The value that the space temperature must exceed to generate a Space Temperature Alarm in the unoccupied mode. There is a fixed hysteresis of 1°F (0.5°C) for return to normal.	95°F	45 to 100°F
SUPPLY AIR TEMPERATURE ALARM		
Low SAT Alarm Limit – The value that the supply air temperature must drop below to generate a Supply Air Temp Alarm . There is a fixed hysteresis of 3°F (1.6°C) for return to normal.	45°F	15 to 90°F
High SAT Alarm Limit – The value that the supply air temperature must exceed to generate a Supply Air Temp Alarm . There is a fixed hysteresis of 3°F (1.6°C) for return to normal.	120°F	90 to 175°F
RETURN AIR TEMPERATURE ALARM		
Low RAT Alarm Limit – The value that the return air temperature must drop below to generate a Return Air Temp Alarm . There is a fixed hysteresis of 3ΔF (1.6ΔC) for return to normal.	45°F	15 to 90°F
High RAT Alarm Limit – The value that the return air temperature must exceed to generate a Return Air Temp Alarm . There is a fixed hysteresis of 3ΔF (1.6ΔC) for return to normal.	45°F	15 to 90°F
AIRSIDE DELTA T ALARMS		
Low Airside Δ T Alarm Limit (Clg) – The value that the airside differential temp must be below when in cooling mode to generate a Airside ΔT Alarm .	5°F	0 to 50°F
High Airside Δ T Alarm Limit (Clg) – The value that the airside differential temp must exceed when in cooling mode to generate a Airside ΔT Alarm .	30°F	0 to 50°F
Low Airside Δ T Alarm Limit (Htg) – The value that the airside differential temp must be below when in heating mode to generate a Airside ΔT Alarm .	3°F	0 to 50°F
High Airside Δ T Alarm Limit (Htg) – The value that the airside differential temp must exceed when in heating mode to generate a Airside ΔT Alarm .	20°F	0 to 50°F
SOURCE W DELTA T ALARMS		
Low SrcW Δ T Alarm Limit (Clg) – The value that the source water differential temp must be below when in cooling mode to generate a SrcW ΔT Alarm .	5°F	0 to 50°F
High SrcW Δ T Alarm Limit (Clg) – The value that the source water differential temp must exceed when in cooling mode to generate a SrcW ΔT Alarm .	30°F	0 to 50°F
Low SrcW Δ T Alarm Limit (Htg) – The value that the source water differential temp must be below when in heating mode to generate a SrcW ΔT Alarm .	3°F	0 to 50°F
High SrcW Δ T Alarm Limit (Htg) – The value that the source water differential temp must exceed when in heating mode to generate a SrcW ΔT Alarm .	20°F	0 to 50°F

Table 11 – Alarm Configuration (cont)

POINT NAME/DESCRIPTION	DEFAULT	RANGE
<i>i-Vu® / Field Assistant Navigation: Properties → Control Program → Configuration → Alarm Configuration</i>		
CONDENSATE OVERFLOW ALARM		
Overflow Alarm Delay – The delay time before an alarm is generated after the alarm condition occurs.	10 sec	5 to 600 sec
RELATIVE HUMIDITY		
Occupied High RH Alarm Limit – The value that the relative humidity sensor must exceed to generate a Space Relative Humidity alarm in the occupied mode.	100% RH	45 to 100% RH
Alarm Delay (min/%RH) – Determines the amount of delay before an occupied RH alarm is generated when the controller transitions to the occupied mode. The delay time equals this value multiplied by the difference between the sensor RH value and the occupied RH setpoint plus 15 minutes.	5 min.	0 to 30 min.
Unocc High RH Alarm Limit – The value that the relative humidity sensor must exceed to generate a Space Relative Humidity alarm in the unoccupied mode.	100% RH	45 to 100% RH
IAQ / VENTILATION ALARM		
Occupied High CO₂ Alarm Limit – The value that the CO ₂ sensor must exceed to generate an Indoor Air Quality Alarm in the occupied mode if DCV Control is set to Enable . There is a fixed hysteresis of 100ppm for return to normal.	1100ppm	0 to 9999 ppm
Alarm Delay (min/ppm) – The fractional portion of a minute used to determine the amount of delay before an indoor air quality alarm is generated when the controller transitions to the occupied mode. The delay time equals this value multiplied by the difference between the sensor CO ₂ value and the setpoint plus 15 minutes.	0.25 min.	0.1 to 1.0 min.
SOURCE WATER VALVE ALARM		
Src Water Valve Alarm Diff – The value of the differential must be exceeded by in order to generate a Src Water Valve Alarm . The differential is the absolute value of the commanded position of the source water valve minus the feedback position (ACT Net only).	5%	0 to 15%
OA DAMPER ALARM		
OA Damper Alarm Diff – The value of the differential must be exceeded by in order to generate a OA Damper Alarm . The differential is the absolute value of the commanded position of the OA damper minus the feedback position (ACT Net only).	5%	0 to 15%
WATER ECONOMIZER VALVE ALARM		
Water Economizer Valve Alarm Diff – The value of the differential must be exceeded by in order to generate a Water Economizer Valve Alarm . The differential is the absolute value of the commanded position of the water economizer valve minus the feedback position (ACT Net only).	5%	0 to 15%
ALARMS DISPLAYED ON ZS SENSOR		
Emergency Shutdown Alarm – If set to display, shows the alarm indicator on the communicating ZS sensor, if the Emergency Shutdown Alarm is active.	Display	Ignore/Display
Space Temperature Alarm – If set to display, shows the alarm indicator on the communicating ZS sensor, if the Space Temperature Alarm is active.	Display	Ignore/Display
Supply Air Temp Alarm – If set to display, shows the alarm indicator on the communicating ZS sensor, if the Supply Air Temperature Alarm is active.	Ignore	Ignore/Display
Return Air Temp Alarm – If set to display, shows the alarm indicator on the communicating ZS sensor, if the Return Air Temperature Alarm is active.	Ignore	Ignore/Display
Compressor Alarm – If set to display, shows the alarm indicator on the communicating ZS sensor, if any Compressor Status Alarm is active.	Display	Ignore/Display
Source Water Temp Alarm – If set to display, shows the alarm indicator on the communicating zone sensors with display, if the Source Water Temperature Alarm is active.	Display	Ignore/Display
Condensate Overflow Alarm – If set to display, shows the alarm indicator on the communicating zone sensors with display, if the Primary or Secondary Condensate Overflow Alarm is active.	Display	Ignore/Display

Table 11 – Alarm Configuration (cont)

POINT NAME/DESCRIPTION	DEFAULT	RANGE
<i>i-Vu® / Field Assistant Navigation: Properties → Control Program → Configuration → Alarm Configuration</i>		
Space High Humidity Alarm – If set to display, shows the alarm indicator on the communicating zone sensors with display, if the Space Relative Humidity alarm is active.	Ignore	Ignore/Display
Space High CO₂ Alarm – If set to display, shows the alarm indicator on the communicating zone sensors with display if the Space CO₂ is in alarm.	Ignore	Ignore/Display
Fan Failure Alarm – If set to display, shows the alarm indicator on the communicating zone sensors with display, if the Supply Fan Failure alarm is active.	Ignore	Ignore/Display
MAINTENANCE DISPLAYED ON ZS SENSOR		
Source Linkage Fault – If set to display, shows the alarm indicator on the communicating zone sensors with display, if the Source Water Linkage Alarm is active.	Ignore	Ignore/Display
Dirty Filter Alarm – If set to display, shows the alarm indicator on the communicating zone sensors with display, if the Filter Alarm is active.	Display	Ignore/Display
Sensor Fault – If set to display, shows the alarm indicator on the communicating zone sensors with display, if any attached Sensor Fault or Failure Alarm is active.	Ignore	Ignore/Display

Table 12 – Maintenance

POINT NAME/DESCRIPTION	DEFAULT	RANGE
<i>i-Vu® / Field Assistant Navigation: Properties → Control Program → Maintenance</i>		
Occupancy Status – The controller's occupancy status as determined by a network input, a local schedule, or remote occupancy input.	—	Unoccupied / Occupied
Fans Amps – The amperage reading from the supply fan current monitor.	—	0 to 10 A
Compressor Amps – The amperage reading from the compressor current monitor.	—	0 to 10 A
Temp Compensated Start – Indicates the state of the Temp Compensated Start algorithm.	—	Inactive / Active
Learning Adaptive Start – Indicates the state of the Learning Adaptive Start algorithm.	—	Inactive / Active
Space Temp Source – The source of the space temperature value.	—	ZS Sensor T55 Sensor Network N/A
Setpoint Adjustment – The amount by which the cooling and heating setpoints have been adjusted.	—	–35 to 240°F
Effective Heat Setpoint – The current heating setpoint. May include offsets from the configured occupied/unoccupied setpoints resulting from Optimal Start or Demand Limit	—	–°F
Effective Cool Setpoint – The current cooling setpoint. May include offsets from the configured occupied/unoccupied setpoints resulting from Optimal Start or Demand Limit.	—	–°F
Relative Humidity Source – The source of the relative humidity value	—	ZS Sensor Network Locked Value N/A
IAQ Source – The source of the indoor air quality value.	—	ZS Sensor Network Locked Value N/A
Ctrl Temp Source – The source of the controlling temperature.	—	RAT Sensor Space Sensor Locked Value
Outdoor Air Temperature Source – The source of the OAT value.	—	Water Linkage Network Locked Value N/A
Demand Limit – The current state of demand limiting.	—	Inactive / Active
System Cooling Demand Level – The current system cooling demand level used by this control. NOTE: Not shown if current level is 0.	—	0 to 3
System Heating Demand Level – The current system heating demand level used by this control. NOTE: Not shown if current level is 0.	—	0 to 3

Table 12 – Maintenance (cont)

POINT NAME/DESCRIPTION	DEFAULT	RANGE
<i>i-Vu® / Field Assistant Navigation: Properties → Control Program → Maintenance</i>		
Aux Heat Control Setpoint – The control setpoint of the auxiliary heat when ACTIVE .	—	72.5 to 105°F
Water Economizer Control Setpoint – The control setpoint of the water economizer heat when ACTIVE .	—	55 to 72.4°F
Calculated DCV Damper Position – The calculated damper position being used for DCV control.	—	0 to 100%
Active Compressor Stages – The number of compressor stages currently operating. NOTE: A value of 1 means one compressor or low speed compressor 1. A value of 2 means two compressors or high speed compressor 1.	—	0 - 2
Emergency Shutdown – The status of the Emergency Shutdown input.	—	Off / On
Secondary Condensate Overflow – The status of the Secondary Condensate Overflow input.	—	Off / On
Flow Switch – The status of the Flow Switch input.	—	No Flow / Flow
Water Meter – The current reading of the water meter.	—	0 to 100 GPM
Reset Filter Alarm – Set this to On to reset an active Filter Alarm and restart the Filter Service Alarm Timer . After the alarm returns to normal, this automatically changes to Off .	Off	Off / On
OCCUPANCY		
BAS On/Off – Determines the occupancy state of the controller and can be set over the network by another device or third party BAS.	Inactive	Inactive / Occupied / Unoccupied
Schedule – The controller's occupancy status based on the local schedule	—	Unoccupied / Occupied
Pushbutton Override – Active indicates if a user pushed the sensor's override button to override the occupancy state.	—	Off / Active
Override Time Remaining – The minutes left that the equipment runs, if activated by override.	—	0 - 960:00 mm:ss
Occupancy Contact – The status of the Remote Occupancy input.	—	Inactive / Active
Local BACnet Schedule	—	Off / On
Configure ZS Sensors by setting the following options in the Local BACnet Schedule popup. Click Local BACnet Schedule to access the popup Properties page > Details tab.		
SENSOR CONFIGURATION		
Allow Force Unoccupied – Check to allow a user to save energy by forcing the zone into an unoccupied schedule on the ZS sensor. The user does this by holding the sensor's On/Off button for at least 3 seconds. This forced state remains in effect until the schedule transitions to unoccupied or until a user presses the sensor's On/Off button again.	Enable	Disable / Enable
Force Unoccupied without Delay – Check to allow a user to force a zone to unoccupied immediately instead of the normal 3-second delay. NOTE: This option is not available if Allow TLO Set During Occupied is checked.	Enable	Disable / Enable
TIMED LOCAL OVERRIDE		
Increment – Minutes that the occupancy control adds to the zone's occupied time for each click of the zone's local override button or switch.	30:00 mm:ss	—
Maximum Duration – Maximum value (up to 960 minutes) the occupancy outputs, regardless of additional pulses from the controller's input.	60:00 mm:ss	0 to 960:00 mm:ss
ENVIRONMENTAL INDEX		
Environmental Index (EI) — Initial Occupied value is 100%. A value of 100% means the zone is Unoccupied . If the space temperature deviates from the Effective Heat Setpoint and Effective Cooling Setpoint range, the value is derated. EI supports an optional RH and CO ₂ sensor. The RH and/or CO ₂ values could also derate an EI.	—	0 to 100%
EI Time Satisfied — Percentage of Occupied time during which a zone maintains and EI of 70% or higher.	—	0 to 100%
Weighted EI — Determines the priority of a zone in an EI roll-up, which must be completed using a different control program.	—	0 to 100000.0
EI Total Weight - Current EI Weighting Factor used to scale the Weighted EI	—	0 to 1000.0

Table 12 – Maintenance (cont)

POINT NAME/DESCRIPTION	DEFAULT	RANGE
<i>i-Vu® / Field Assistant Navigation: Properties → Control Program → Maintenance</i>		
EI Decreased By — Source(s) of an EI value reduction. Options: Temp — EI Decreased by Space Temperature Temp and RH — EI decreased by Space Temperature and Relative Humidity Temp, RH and CO₂ — EI decreased by Space Temperature, Relative Humidity and CO ₂ RH — EI decreased by Relative Humidity RH and CO₂ — EI decreased by Relative Humidity and CO ₂ CO₂ — EI decreased by CO ₂ Temp and CO₂ — EI decreased by Space	—	Temp Temp and RH Temp, RH and CO ₂ RH RH and CO ₂ CO ₂ Temp and CO ₂ None
EI Space Temp Setpoint Tolerance — Expands the ideal heating and cooling setpoint range for EI temperature sensitivity.	±0.5°F	±0 to 5°F
EI Humidity Low Limit — Setpoint value that relative humidity must drop below in order to decrease an EI Value.	30%	0 to 100%
EI Weighting Factor — Creates a weighted average of a zone EI value by indicating the priority of that zone in an EI roll-up. A value of 0 disables the zone from an EI roll-up.	1	0 to 1000.0

Table 13 – Linkage Configuration

POINT NAME/DESCRIPTION	DEFAULT	RANGE
<i>i-Vu® / Field Assistant Navigation: Properties → Control Program → Linkage</i>		
SOURCE WATER LINKAGE		
Waterside Linkage Collector – Set the Number of Providers to the total number of controllers in the linked system. When configured, the controller can collect information from other WSHP TruVu controllers.	1	1 to 64
Waterside Linkage Provider – Allows access to configuration of a water linkage system and to the Provider's details. Enter the Network Number and MAC Address of the controller that runs the Loop Pump Monitor control program. Water source: Network Number = • IP Address =	0 0.0.0.0	0 to 65,534 0.0.0.0 to 255.255.255.255
NOTE :If you change the Network Number or Address from a BACview device, you must cycle power to the controller for the changes to take effect.		
Source Water Linkage – If Active , the controller is part of a linked system. If Not Active , the controller is a stand-alone device.	—	Active/Not Active
Loop Pump Request – Set to 1 if this WSHP requires the source water loop to operate.	—	0 or 1
Loop Pump Status – The actual state of the source water loop pump(s).	—	Off / On
Heat Request – Set to 1 if this WSHP is required to operate in a heating mode.	—	0 or 1
Cool Request – Set to 1 if this WSHP is required to operate in a cooling mode.	—	0 or 1
Water Loop Temperature – Displays the actual temperature of the source water leaving the plant and entering this WSHP.	—	–56 to 245°F
Aux Heat Request – Set to 1 if this WSHP requires the auxiliary heat source to operate.	—	0 or 1
Aux Heat HW Pump Status – The actual state of the auxiliary heat (boiler) pump(s).	—	Off / On
Aux Heat Boiler Water Temp – Displays the actual temperature of the boiler water leaving the plant and entering this WSHP's auxiliary heating coil. A value of –999°F indicates the value is unavailable.	–999°F	–56 to 245°F
Outdoor Air Temp – Displays the outdoor air temperature being sent to this WSHP through Source Water Linkage . A value of –999°F indicates the value is unavailable.	–999°F	–56 to 245°F

Table 14 — UPM Modbus Integration

POINT NAME/DESCRIPTION	DEFAULT	RANGE
<i>i-Vu® / Field Assistant Navigation: Properties → Control Program → UPM Modbus Integration</i>		
UPM MODBUS INTEGRATION		
UPM Modbus boards required — The number of required UPM boards required based upon the number of compressors configured.	—	1 or 2
UPM Modbus boards online — The number of required UPM boards detected via Modbus integration.	—	1 or 2
A2L Mitigation Mode — Current status of A2L mitigation	—	
UPM MODBUS SINGLE STAGE BOARD CURRENT STATUS		
UPM Firmware Version Stage 1 — Reports the decimal number of the current software version.	—	
System Configuration Stage 1 — Reports the numerical value of the system configuration.	—	
Hard Lockout Status Stage 1 — Reports the appropriate fault code when a fault causes hard lockout.	—	
Current Fault Status Stage 1 — Reports the fault code of the current status (0x0000 = no faults).	—	
Soft Lockouts Stage 1 — Reports the latest softlock code (0x0000 = none).	—	
Y Call Stage 1 — 0 = no call, 1 = call	—	0 or 1
HPS Status Stage 1 — 0 = open, 1 = closed	—	0 or 1
LPS Status Stage 1 — 0 = open, 1 = closed	—	0 or 1
Condensate Status — 0 = open, 1 = closed	—	0 or 1
Compressor Contactor Status Stage 1 — 0 = Off, 1 = On	—	0 or 1
DIP SW(1) Lockout Switch Stage 1 — 0 = 2, 1 = 4	—	0 or 1
DIP SW(2) Reset Switch Stage 1 — 0 = Y, 1 = R	—	0 or 1
DIP SW(3) Alarm Switch Stage 1 — 0 = Pulse, 1 = Continuous	—	0 or 1
DIP SW(4) Test Switch Stage 1 — 0 = No, 1 = Yes	—	0 or 1
DIP SW(5) Freeze 1 Switch Stage 1 — 0 = 25°, 1 = 15°	—	0 or 1
DIP SW(6) Freeze 2 Switch Stage 1 — 0 = 25 deg, 1 = 15°	—	0 or 1
Running Soft Lockouts Stage 1 — Reports the number of soft lockouts that have occurred since the last hard lockout (this value is 0 if the control is currently in hard lockout).	—	
Comp Start Requests Stage 1 — Reports the lifetime total of Y calls from the thermostat.	—	
Comp Starts Stage 1 — Reports the lifetime total of successful compressor starts.	—	
Comp Runtime Stage 1 — Reports the lifetime total duration of compressor runtime in a .01-hour resolution.	—	
Freeze 1 Temp Stage 1 — Reports the current temperature sensed by the Freeze 1 input in a 1°F resolution. The possible range is 0 to 160°F.	—	0 to 160°F
Freeze 2 Temp Stage 1 — Reports the current temperature sensed by the Freeze 2 input in a 1°F resolution. The possible range is 0 to 160°F.	—	0 to 160°F
Hard Lockout Status Stage 1 — Reports the appropriate fault code when a fault causes hard lockout.	—	
Current Fault Status Stage 1 — Reports the fault code of the current status (0x0000 = no faults).	—	
System Configuration Stage 1 — [BIT FIELD] Indicates which devices are expected by the LPR-BG1707 on the sensor RS-485 network. (Note that this register will hold an immutable value of 0x0004 for LPR-BK1701, since it is a Modbus slave and does not ping the sensors for data.) a. Bit 0: 0 = no device detected, 1 = Sensor 1 required b. Bit 1: 0 = no device detected, 1 = Sensor 2 required c. Bit 2: 0 = no device detected, 1 = 2nd-stage board required	—	
UPM 1 Valid — Reports the validity of UPM Board 1	—	
UPM MODBUS TWO STAGE BOARD CURRENT STATUS		
UPM Firmware Version Stage 2 — Reports the decimal number of the current software version.	—	
System Configuration Stage 2 — Reports the numerical value of the system configuration.	—	
Hard Lockout Status Stage 2 — Reports the appropriate fault code when a fault causes hard lockout.	—	
Current Fault Status Stage 2 — Reports the fault code of the current status (0x0000 = no faults).	—	
Soft Lockouts Stage 2 — Reports the latest softlock code (0x0000 = none).	—	
Y Call Stage 2 — 0 = no call, 1 = call	—	0 or 1

Table 14 – UPM Modbus Integration (cont)

POINT NAME/DESCRIPTION	DEFAULT	RANGE
<i>i-Vu® / Field Assistant Navigation: Properties → Control Program → UPM Modbus Integration</i>		
HPS Status Stage 2 — 0 = open, 1 = closed	—	0 or 1
LPS Status Stage 2 — 0 = open, 1 = closed	—	0 or 1
Compressor Contactor Status Stage 2 — 0 = Off, 1 = On	—	0 or 1
DIP SW(1) Lockout Switch Stage 2 — 0 = 2, 1 = 4	—	0 or 1
DIP SW(2) Reset Switch Stage 2 — 0 = Y, 1 = R	—	0 or 1
DIP SW(3) Alarm Switch Stage 2 — 0 = Pulse, 1 = Continuous	—	0 or 1
DIP SW(4) Test Switch Stage 2 — 0 = No, 1 = Yes	—	0 or 1
DIP SW(5) Freeze 1 Switch Stage 2 — 0 = 25 deg, 1 = 15°	—	0 or 1
DIP SW(6) Freeze 2 Switch Stage 2 — 0 = 25 deg, 1 = 15°	—	0 or 1
Running Soft Lockouts Stage 2 — Reports the number of soft lockouts that have occurred since the last hard lockout (this value is 0 if the control is currently in hard lockout).	—	
Comp Start Requests Stage 2 — Reports the lifetime total of Y calls from the thermostat.	—	
Comp Starts Stage 2 — Reports the lifetime total of successful compressor starts.	—	
Comp Runtime Stage 2 — Reports the lifetime total duration of compressor runtime in a 0.01-hour resolution.	—	
Freeze 1 Temp Stage 2 — Reports the current temperature sensed by the Freeze 1 input in a 1°F resolution. The possible range is 0 to 160°F.	—	0 to 160°F
Freeze 2 Temp Stage 2 — Reports the current temperature sensed by the Freeze 2 input in a 1°F resolution. The possible range is 0 to 160°F.	—	0 to 160°F
Hard Lockout Status Stage 2 — Reports the appropriate fault code when a fault causes hard lockout.	—	
Current Fault Status Stage 2 — Reports the fault code of the current status (0x0000 = no faults).	—	
System Configuration Stage 2 — [BIT FIELD] Indicates which devices are expected by the LPR-BG1707 on the sensor RS-485 network. (Note that this register will hold an immutable value of 0x0004 for LPR-BK1701, since it is a Modbus slave and does not ping the sensors for data.) a. Bit 0: 0 = no device detected, 1 = Sensor 1 required b. Bit 1: 0 = no device detected, 1 = Sensor 2 required c. Bit 2: 0 = no device detected, 1 = 2nd-stage board required	—	
UPM 2 Valid — Reports the validity of UPM Board 2	—	

Table 15 – CEC Title 24

POINT NAME/DESCRIPTION	DEFAULT	RANGE
<i>i-Vu® / Field Assistant Navigation: Properties → Control Program → CEC Title 24</i>		
CONFIGURATION		
Enable CEC Title 24 — Enables CEC Title 24 algorithm	Disable	Disable / Enable
Occupied Standby — Enables Occupied Standby Routine of CEC Title 24	Disable	Disable / Enable
Occupied Standby Delay — The amount of time the controller remains occupied after the presence sensor returns to the unoccupied position	—	0 to 15 min.
Occupied Standby Offset — The value by which the occupied setpoints are expanded when the space presence sensor or Title 24 compliant system indicates that a Space/Zone is unoccupied.	2°F	0.5 to 15°F
Inhibit Occupied Standby from this zone? — If Yes, Occupied Standby functionality is ignored by this controller.	—	No / Yes
Maintenance		
Occupied Standby Source — The source of the presence value. ZS Sensor – A ZS sensor is connected to the controller’s Rnet port. Network – A network presence sensor is bound to the controller’s presence BV. Locked Value – The controller’s presence input has been manually locked at a value.	—	ZS Sensor Network Locked Value Sensor Failure
Occupied Standby Mode — The controller’s current occupied Standby operating mode. Inactive – Presence sensed in Space/Zone. Fan Off – No demand in Space/Zone. Supply Fan is off. Heating – Supply Fan is on and providing heat. Space Temperature is less than the Effective Heat Setpoint. Cooling – Supply Fan is on and providing cooling. Space Temperature is greater than the Effective Cool setpoint. Fan Running – Supply Fan is on.	—	Inactive Fan Off Heating Cooling Fan Running
Occupied Standby Delay — The status of the Occupied Standby presence delay.	—	Inactive / Active
Remaining Occupied Standby Delay — If Occupied Standby Delay is Active , this is the remaining delay time.	—	0 to 15 min.

Table 16 – I/O Points

POINT NAME/DESCRIPTION	RANGE
<i>i-Vu® / Field Assistant Navigation: Properties → I/O Points</i>	
WARNINGS	
Do not change the Value, Offset/Polarity, Exp:Num, I/O Type, Sensor/Actuator Type, Min/Max, or Resolution I/O configuration parameter for the points listed below. Changing these parameters could cause improper control and/or equipment damage.	
Use extreme caution if locking a point as this may also cause improper control and/or equipment damage. 	
Compressor Current — Raw input value in Volts of the Compressor Current input if configured.	0 to 10-v
Fan Current — Raw input value in Volts of the Fan Current input if configured.	0 to 10-v
SAT Sensor — The value of the controller’s supply air temperature sensor input, prior to any operator-configured Calibration Offset.	–35 to 240°F
Source Leaving Water Temperature — The temperature of the water leaving the compressor’s source water loop.	–35 to 240°F
Source Entering Water Temperature — The temperature of the water entering the compressor’s source water loop.	–35 to 240°F
input_6 — Input 6, 10K Thermistor Only, User configurable for RAT or T55.	–35 to 240°F
Src Water Valve Pos — ACTNet input for Src Water Valve feedback if configured.	0 to 100%
Water Economizer Pos — ACTNet input for Water Economizer feedback if configured.	0 to 100%
OA Damper Pos — ACTNet input for OA Damper feedback if configured.	0 to 100%
Zone CO₂ — IAQ/CO ₂ signal received from CO ₂ enabled ZS Sensors.	___ PPM
Zone Humidity — The value provided by the controller’s ZS Sensor.	0 to 100%
Zone Temp — The value provided by the controller’s ZS Sensor.	___ °F
Compressor Status — Indicates the current state of the compressor status input.	Off / On
Fan Status — Indicates the current state of the fan status input.	Off / On
input_7_bi — Input 7, Dry Contact, User configurable for Emergency Shutdown, Remote Occupancy, Secondary Condensate Overflow or Flow Switch.	Off / On
input_8_bi — Input 8, Dry Contact, User configurable for Emergency Shutdown, Remote Occupancy, Secondary Condensate Overflow or Flow Switch.	Off / On
input_7_ai — Analog Input 7, 0 - 10v, User configurable for Water Meter.	0 to 10-v

Table 16 – I/O Points (cont)

POINT NAME/DESCRIPTION	RANGE
<i>i-Vu® / Field Assistant Navigation: Properties → I/O Points</i>	
input_8_ai — Analog Input 8, 0 - 10v, User configurable for Water Meter.	0 to 10-v
Rnet Sensed Occupancy — Displays occupancy status detected by the wireless infrared motion sensor.	Off / On
Supply Fan VFD — Universal Output 1, 0-10 vdc, Provides VFD output signal used for variable speed fan control if configured.	0 to 10-v
ECM Fan — Universal Output 1, 80 Hz PWM, Provides pulse-width modulation output signal used for variable speed fan control if configured.	0 to 10-v
AO-2 — Analog Output 2,0-10 vdc, User configurable for Aux Heat SCR, Water Economizer, OA Damper, Src Water Valve,Aux Heat Modulating HWV, Dehumidification	0 to 10-v
AO-3 — Analog Output 3,0-10 vdc, User configurable for Aux Heat SCR, Water Economizer, OA Damper, Src Water Valve,Aux Heat Modulating HWV	0 to 10-v
Src Water Valve Cmd — ACTNet onput for Src Water Valve Command if configured.	0 to 100%
Water Economizer Cmd — ACTNet onput for Water Economizer Command if configured.	0 to 100%
OA Damper Cmd — ACTNet output for OA Damper Command if configured.	0 to 100%
Fan G — Universal Output 1, The current commanded output for the fan. Can be single speed ON command or Low Speed command for multispeed fans (PSC configuration only).	Off / On
Y1 — Binary Output 2, The current compressor commanded output.	Off / On
BO-3 — Binary Output 3, User configurable for Reversing Valve or Electric Heat W1.	Off / On
BO-4 — Binary Output 4, User configurable for Water Economizer, Electric Heat W1, Electric Heat W2, Hot Water Valve W1, Hot Water Valve W2, 2nd Stage Compressor Y2, High Speed Compressor Y2	Off / On
BO-5 — Binary Output 5, User configurable for Water Economizer, Electric Heat W1, Electric Heat W2, Hot Water Valve W1, Hot Water Valve W2, Cycle with Fan, Cycle with Compressor, Dehumidification	Off / On
BO-6 — Binary Output 6, User configurable for Water Economizer, Electric Heat W1, Electric Heat W2, Hot Water Valve W1, Hot Water Valve W2, Cycle with Fan, Cycle with Compressor, Source Water Valve, Fan G2	Off / On
BO-7 — Binary Output 7, User configurable for Water Economizer, Electric Heat W1, Electric Heat W2, Hot Water Valve W1, Hot Water Valve W2, Cycle with Fan, Cycle with Compressor, Source Water Valve, VFD Enable, Fan G3	Off / On

Table 17 – Controller Status Commands

POINT NAME/DESCRIPTION	DEFAULT	RANGE
<i>i-Vu® / Field Assistant Navigation: Properties → Control Program → Status</i>		
System Mode — The controller's current operating mode.	—	OFF, Fan Only, Economize, Cooling, Heating, Continuous Fan, Test, Start Delay, Dehumidify, Emerg. Shutdown, Manual Shutdown, IAQ Override, I/O Config Error
Shutdown Reason — The reason for unit shutdown.	—	Normal Operation, CTRL Temp Sensor Failure, SAT Sensor Failure, Condensate Overflow, Hard Lockout from UPM, Emergency Shutdown
Controlling Temperature — The temperature currently used for control.	—	-35 to 240°F
Space Temperature — The space temperature value.	—	-35 to 240°F
Supply Air Temperature — Displays the current supply air temperature.	—	-35 to 240°F
Return Air Temperature — Displays the current return air temperature.	—	-35 to 240°F
Airside Delta T — Displays the absolute difference between SAT and RAT.	—	0 to 100°F
Leaving SrcW Temp — Displays the current leaving source water temperature.	---	-35 to 240°F
Entering SrcW Temp — Displays the current entering source water temperature.	—	-35 to 240°F
SrcW Delta T — Displays the absolute difference between Ent SrcW and Lvg SrcW Temps.	—	0 to 100°F
Outdoor Air Temperature — Displays the current outside air temperature.	—	-35 to 240°F
Fan/Speed — The commanded state of the supply fan.	—	Off, Low, Med, High, Off
Supply Fan Status — Displays the current operating status of the supply fan.	—	Off / On
Compressor Capacity — The percentage of compressors running.	—	0 to 100%
Source Water Valve — The commanded state of the SrcW valve.	—	Close / Open

Table 17 – Controller Status Commands

POINT NAME/DESCRIPTION	DEFAULT	RANGE
<i>i-Vu® / Field Assistant Navigation: Properties → Control Program → Status</i>		
Src Water Valve Ctrl Output — The commanded position of the SrcW valve.	—	0 to 100%
Src Water Valve Feedback — The Act Net feedback position of the ScrW valve.	—	0 to 100%
Flow — Displays condenser water flow state.	—	No Flow/Flow
OA Damper Ctrl Output —The commanded position of the OA damper.	—	0 to 100%
OA Damper Feedback — The Act Net feedback position of the OA damper.	—	0 to 100%
Water Economizer Output — The commanded position of the water economizer.	—	0 to 100%
Water Economizer Feedback — The Act Net feedback position of the water economizer.	—	0 to 100%
Water Economizer — The commanded state of the water economizer with a two position valve.	—	Inactive / Active
Aux Heat Ctrl Output — The commanded output of the aux heat.	—	0 to 100%
Space Relative Humidity — Displays the current space relative humidity.	—	0 to 100% RH
Dehumidification — Displays the current status of dehumidification request.	—	Inactive / Active
Dehum Ctrl Output — Displays the current commanded position of the MHGRH valve.	—	0 to 100%
Indoor Air Quality CO₂ (ppm) — Displays the current CO ₂ value.	—	0 to 9999 ppm
Shutdown — When Active, provides a means to stop the unit in an orderly manner.	Inactive	Inactive / Active

Table 18 – Occupied Cooling and Heating Setpoints

POINT NAME/DESCRIPTION	DEFAULT RANGE: –40°F TO 245°F			
	OCCUPIED	DEMAND LEVEL		
		1	2	3
<i>i-Vu® / Field Assistant Navigation: Properties → Control Program → Configuration → Setpoints</i>				
Occupied Heating: Green The heating setpoint the controller maintains while in occupied mode.	70°F	69°F	68°F	66°F
Occupied Cooling: Green The cooling setpoint the controller maintains while in occupied mode.	76°F	77°F	78°F	80°F
Occupied Heating 1: Light Blue The space temperature must be less than the Occupied Heating 1 setpoint for the VVT Primary to consider the zone a heating caller in a linked system. In a single-zone application, the heating requirement begins as soon as the space temperature falls below the Occupied Heating setpoint. Carrier recommend that the Occupied Heating 1 value be set no less than 0.5°F(0.27°C) below the Occupied Heating setpoint.	69°F	68°F	67°F	65°F
Occupied Heating 2: Dark Blue The space temperature must be less than the Occupied Heating 2 setpoint to generate a low space temperature alarm. Carrier recommend that this value be set no less than 0.5°F (0.27°C) below the Occupied Heating 1 setpoint.	67°F	66°F	65°F	63°F
Occupied Cooling 1: Yellow The space temperature must be greater than the Occupied Cooling 1 setpoint for the VVT Primary to consider the zone a cooling caller in a linked system. In a single-zone application, the cooling requirement begins as soon as the space temperature exceeds the Occupied Cooling setpoint. Carrier recommend that the Occupied Cooling 1 value be set no less than 0.5°F (0.27°C) above the Occupied Cooling setpoint.	77°F	78°F	79°F	81°F
Occupied Cooling 2: Orange The space temperature must be greater than the Occupied Cooling 2 setpoint to generate a high space temperature alarm. Carrier recommend that this value be set no less than 0.5°F (0.27°C) above the Occupied Cooling 1 setpoint.	79°F	80°F	81°F	83°F

Table 19 – Unoccupied Cooling and Heating Setpoints

POINT NAME/DESCRIPTION	DEFAULT	RANGE
<i>i-Vu® / Field Assistant Navigation: Properties → Control Program → Configuration → Setpoints</i>		
Unoccupied Heating: Gray The heating setpoint the controller maintains while in unoccupied mode.	55°F	-40 to 245°F
Unoccupied Cooling: Gray The cooling setpoint the controller maintains while in unoccupied mode.	90°F	-40 to 245°F
Unoccupied Heating 1: Light Blue The space temperature must be less than the Unoccupied Heating 1 setpoint for the VVT Primary to consider the zone an unoccupied heating caller in a linked system. In a single-zone application, the unoccupied heating requirement begins as soon as the space temperature falls below the Unoccupied Heating setpoint. We recommend that the Unoccupied Heating 1 value be set no less than 0.5 °F (0.27°C) below the Unoccupied Heating setpoint.	54°F	-40 to 245°F
Unoccupied Heating 2: Dark Blue The space temperature must be less than the Unoccupied Heating 2 setpoint to generate an unoccupied low space temperature alarm. We recommend that this value be set no less than 0.5 °F (0.27 °C) below the Unoccupied Heating 1 setpoint.	52°F	-40 to 245°F
Unoccupied Cooling 1: Yellow The space temperature must be greater than the Unoccupied Cooling 1 setpoint for the VVT Primary to consider the zone an unoccupied cooling caller in a linked system. In a single-zone application, the unoccupied cooling requirement begins as soon as the space temperature exceeds the Unoccupied Cooling setpoint. We recommend that the Unoccupied Cooling 1 value be set no less than 0.5°F (0.27°C) above the Unoccupied Cooling setpoint.	91°F	-40 to 245°F
Unoccupied Cooling 2: Orange The space temperature must be greater than the Unoccupied Cooling 2 setpoint to generate an unoccupied high space temperature alarm. We recommend that this value be set no less than 0.5°F (0.27°C) above the Unoccupied Cooling 1 setpoint.	93°F	-40 to 245°F
Heating Capacity: Used for Optimal Start, this is the rate at which the space temperature changes when the heating system runs at full capacity to maintain designed occupied heating setpoint.	3°F/hr	0 to 120°F/hr
Heating Design Temperature: The geographically based outdoor air temperature at which the heating system must run constantly to maintain comfort. This information is available in ASHRAE publications and most design references.	0°F	-100 to 150°F
Cooling Capacity: Used for Optimal Start, this is the rate at which the space temperature changes when cooling system runs at full capacity to maintain designed occupied cooling setpoint.	3°F/hr	0 to 140°F
Cooling Design Temperature: The geographically based outdoor air temperature at which the cooling system must run constantly to maintain comfort. This information is available in ASHRAE publications and most design references.	100°F	-100 to 150°F
Hysteresis: The desired difference between the temperature at which the zone color changes as the space temperature departs from the acceptable range between the heating and cooling setpoints (green) into the Cooling 1 (yellow) or Heating 1 (light blue) and the temperature at which the zone color changes back to the acceptable range between the heating and cooling setpoints.	0.5°F	0 to 120°F

Table 20 – Learning Adaptive Algorithms

POINT NAME/DESCRIPTION	DEFAULT	RANGE
<i>i-Vu® / Field Assistant Navigation: Properties → Control Program → Configuration → Setpoints</i>		
Red: The amount the zone’s learned heating capacity is adjusted when the Learning Adaptive Optimal Start algorithm runs, when the zone’s thermographic color at occupancy is red.	0.19	0 to 1
DkBlue: The amount the zone’s learned heating capacity is adjusted when the Learning Adaptive Optimal Start algorithm runs, when the zone’s thermographic color at occupancy is dark blue.	0.13	0 to 1
LtBlue: The amount the zone’s learned heating capacity is adjusted when the Learning Adaptive Optimal Start algorithm runs, when the zone’s thermographic color at occupancy is light blue.	0.06	0 to 1
Green: The amount the zone’s learned heating capacity is adjusted when the Learning Adaptive Optimal Start algorithm runs, when the zone’s thermographic color at occupancy is green.	0.06	0 to 1
SpGrn: The amount the zone’s learned cooling capacity is adjusted when the Learning Adaptive Optimal Start algorithm runs, when the zone’s thermographic color at occupancy is green.	0.06	0 to 1
Yellow: The amount the zone’s learned cooling capacity is adjusted when the Learning Adaptive Optimal Start algorithm runs, when the zone’s thermographic color at occupancy is yellow.	0.06	0 to 1
Orange: The amount the zone’s learned cooling capacity is adjusted when the Learning Adaptive Optimal Start algorithm runs, when the zone’s thermographic color at occupancy is orange.	0.13	0 to 1
Red: The amount the zone’s learned cooling capacity is adjusted when the Learning Adaptive Optimal Start algorithm runs, when the zone’s thermographic color at occupancy is red.	0.19	0 to 1

Table 21 — Effective Setpoints

POINT NAME/DESCRIPTION	DEFAULT	RANGE
<i>i-Vu® / Field Assistant Navigation: Properties → Control Program → Configuration → Setpoints</i>		
Heating — (Occupied or Unoccupied, depending on mode) The current programmed Heating setpoint adjusted by any offset that may be in effect.	—	0 to 120°F
Cooling — (Occupied or Unoccupied, depending on mode) The current programmed Cooling setpoint adjusted by any offset that may be in effect.	—	0 to 120°F
Learned Cooling Capacity — The cooling capacity learned by Learning Adaptive Optimal Start that is required to bring the space temperature down to the occupied cooling setpoint prior to the occupied time.	—	—
Learned Heating Capacity — The heating capacity learned by Learning Adaptive Optimal Start that is required to bring the space temperature up to the occupied heating setpoint prior to the occupied time.	—	—
Optimal Start — The number of hours prior to occupancy, at which the Optimal Start function may begin to adjust the effective setpoints to achieve the occupied setpoints by the time scheduled occupancy begins. Enter 0 to disable Optimal Start.	1 hr	0 to 4 hr
Optimal Start Type — The method used to change from unoccupied to occupied setpoint. Options: None — Unit will not change to occupied setpoint until the scheduled time or the unit goes into an occupied mode. Setpoints do not ramp, but change immediately from unoccupied to occupied values. Temp Compensated — Unit changes to occupied setpoints at a variable time prior to the occupied time, which is calculated by the current difference between space temperature and the appropriate heating or cooling setpoint. At that time, the setpoints do not ramp, but change immediately from unoccupied to occupied values. Learning Adaptive Start — Unit gradually changes to occupied setpoints by adjusting the unoccupied setpoints over a specified period of time to achieve the occupied setpoint by the time scheduled occupancy begins.	Temperature Compensated	None, Temperature Compensated, Learning Adaptive
Heat Start K factor (min/deg) — If Optimal Start Type is Temp Compensated, this is the time in minutes per degree that the equipment starts before the occupied period when the space temperature is below the occupied heating setpoint (including any setpoint offset).	15.00	0 to 99
Cool Start K factor (min/deg) — If Optimal Start Type is Temp Compensated, this is the time in minutes per degree that the equipment starts before the occupied period when the space temperature is above the occupied cooling setpoint (including any setpoint offset).	15.00	0 to 99
Occ Relative Humidity Setpoint — The control setpoint used during occupied periods.	60%	0 to 100%
Unocc Relative Humidity Setpoint — The control setpoint used during unoccupied periods.	95%	0 to 100%
DCV Start Ctrl Setpoint — The value that the CO ₂ level must exceed to begin the IAQ control function.	500 ppm	0 to 9999 ppm
DCV Max Ctrl Setpoint — The value that the CO ₂ level must exceed for the IAQ function to control the damper to its DCV Max Vent Damper Pos.	1050 ppm	0 to 9999 ppm
Clg Src Water Diff Stpt — The current setpoint being used for source water valve control.	10°F	0 to 20°F
Htg Src Water Diff Stpt as % Clg Stpt — The differential setpoint for the source water valve during heating mode as a % of the Clg Src Water Diff Stpt.	75%	0 to 100%
Htg Src Water Diff Stpt — The effective setpoint for the source water valve during heating mode.	—	0 to 20°F
Effective Src Water Diff Stpt — The current setpoint being used for source water valve control.	—	0 to 20°F

Table 22 — ZS Sensor Setpoint

POINT NAME/DESCRIPTION	DEFAULT	RANGE
<i>i-Vu® / Field Assistant Navigation: Properties → Control Program → Configuration → Setpoints</i>		
Edit Increment — Amount of offset in degrees for each press of the up or down arrows on the ZS for setpoint adjustment.	0.5	0.1, 0.5, 1.0
Allow Setpoint Adjust — Check to allow setpoint adjustments on the specified ZS.	(1) Enabled	Disabled/Enabled
Sensor Setpoint Adjust Option — Check to select the ZS or wireless setpoint adjustment display.	3	—

Table 23 – Unit Configuration

POINT NAME/DESCRIPTION	DEFAULT	RANGE
<i>i-Vu® / Field Assistant Navigation: Properties → Control Program → Configuration → Unit Configuration</i>		
Occupancy Source — The method that the controller uses to determine occupancy.	Always Occupied	Always Occupied, BACnet Schedule, BAS On/Off, Remote Occ Input
Heat Enable — Enables or disables heating operation.	Enable	Disable / Enable
Cool Enable — Enables or disables cooling operation.	Enable	Disable / Enable
Fan Mode — The supply fan's operating mode. Options: Auto — The fan cycles on/off in conjunction with heating or cooling. Continuous — The fan runs continuously during occupancy and intermittently during unoccupied periods with heating or cooling. Always On — The fan runs continuously regardless of occupancy or calls for heating and cooling.	Continuous	Auto, Continuous, Always On
Fan On Delay — How long the fan should delay starting after heating or cooling starts	10 sec	0 to 30 sec
Fan Off Delay — How long the supply fan runs after receiving a valid stop command.	90 sec	0 to 180 sec
ZS Fan Speed / Mode Selection — Enables or disables ZS control of fan speed.	Disable	Disable / Enable
Compressor on Delay — The time the compressor should delay starting after flow is proven.	120 sec	0 to 300 sec
OCC Override Delay — The amount of time the controller remains occupied after the remote occupancy switch returns to the unoccupied position.	15 min.	0 to 240 min.
Minimum Cooling SAT — In cooling mode, the cooling outputs are controlled so that the supply air temperature does not drop below this value.	50°F	40 to 60°F
Maximum Heating SAT — In heating mode, the heating outputs are controlled so the supply air temperature does not rise above this value.	110°F	40 to 140°F
Vent Dmpr Pos / DCV Min Pos — The minimum outdoor air damper position maintained during occupied periods.	20%	0 to 100%
DCV Max Vent Damper Pos / Vent Damper Pos — The maximum outdoor air damper position allowed while DCV is active.	100%	0 to 100%
Filter Service Alarm Timer — The amount of time the fan will run before generating a Filter Alarm. Set to 0 to disable the alarm and reset accumulated fan hours.	600 hrs	0 to 10000 hrs
T55 Pushbutton Override — Enables or disables the use of a T55 pushbutton override	Enable	Disable / Enable
T55 Override Duration — This is the amount of time that the controller runs in the occupied mode when a user presses the T55 sensor's override button for 1 to 10 seconds.	1 hr	1 to 3 hrs
Setpoint Adjustment — Enables or disables the setpoint adjustment mechanism on the local space sensor	Enable	Disable / Enable
Setpoint Adjustment Range — The maximum amount that a user can adjust the setpoint on the local SPT sensor.	5°F	0 to 5°F
Cooling OAT Lockout Temp — Cooling is inhibited below this outdoor air temperature.	45°F	-65 to 80°F
Heating OAT Lockout Temp — Heating is inhibited above this outdoor air temperature	65°F	35 to 150°F
Power Fail Restart Delay — How long the controller delays normal operation after the power is restored.	180 sec	0 to 600 sec

Table 23 — Unit Configuration (cont)

POINT NAME/DESCRIPTION	DEFAULT	RANGE
<i>i-Vu® / Field Assistant Navigation: Properties → Control Program → Configuration → Unit Configuration</i>		
INPUT CONFIGURATIONS		
Input 4 Function — Function assigned to Input 4. If Compressor Current is selected, the INPUT NUMBER for Compressor Status on the I/O Points tab in i-Vu must be changed from 4 to 0 and the INPUT NUMBER for Compressor Current must be changed from 0 to 4.	No Function	Compressor Status, Compressor Current, No Function
Input 5 Function — Function assigned to Input 5. If Fan Current is selected, the INPUT NUMBER for Fan Status on the I/O Points tab in i-Vu must be changed from 5 to 0 and the INPUT NUMBER for Fan Current must be changed from 0 to 5.	No Function	Fan Status, Fan Current, No Function
Input 6 Function — Function assigned to Input 6.	No Function	RAT Sensor, T55 Sensor, No Function
Input 7 Function — Function assigned to Input 7. If Water Meter is selected, change input_7_bi INPUT NUMBER from 7 to 0 and input_7_ai INPUT NUMBER from 0 to 7 on the I/O Points tab.	No Function	No Function, Emergency Shutdown, Remote Occupancy, Sec Cond Overflow, Flow Switch, Water Meter
Input 7 Switch Configuration — Normally Open or Normally Closed Configuration of Input 7 Switch	N/O	N/O, N/C
Input 8 Function — Function assigned to Input 8. If Water Meter is selected, change input_8_bi INPUT NUMBER from 8 to 0 and input_8_ai INPUT NUMBER from 0 to 8 on the I/O Points tab.	No Function	No Function, Emergency Shutdown, Remote Occupancy, Sec Cond Overflow, Flow Switch, Water Meter
Input 8 Switch Configuration — Normally Open or Normally Closed Configuration of Input 8 Switch	N/O	N/O, N/C
Input Configuration Status — Checks the the validity of the input configurations. Ensures one or more inputs are not configured for the same function.	—	Invalid, Valid
OUTPUT CONFIGURATIONS		
UO1 Function — Function assigned to Universal Output 1.	PSC/CT ECM/G1	PSC/CT ECM/G1, CA ECM, VFD
AO2 Function — Function assigned to Analog Output 2.	No Function	No Function, Aux Heat SCR, Water Economizer, OA Damper, Source Water Valve, Aux Heat Mod HW Vlv, Dehumidification
AO3 Function — Function assigned to Analog Output 3.	No Function	No Function, Aux Heat SCR, Water Economizer, OA Damper, Source Water Valve, Aux Heat Mod HW Vlv
BO3 Function — Function assigned to Binary Output 3.	Reversing Valve	No Function, Reversing Valve, Electric Heat W1
BO4 Function — Function assigned to Binary Output 4.	No Function	No Function, Water Economizer, Electric Heat W1, Electric Heat W2, Hot Water Valve W1, Hot Water Valve W2, 2nd Stg Compressor Y2, High Spd Compressor Y2
BO5 Function — Function assigned to Binary Output 5.	No Function	No Function, Water Economizer, Electric Heat W1, Electric Heat W2, Hot Water Valve W1, Hot Water Valve W2, Cycle w/ Fan, Cycle w/ Compressor, Dehumidification
BO6 Function — Function assigned to Binary Output 6.	No Function	No Function, Water Side Economizer, Electric Heat W1, Electric Heat W2, Hot Water Valve W1, Hot Water Valve W2, Cycle w/ Fan, Cycle w/ Compressor, Source Water Valve, Fan G2 (CT ECM)
BO7 Function — Function assigned to Binary Output 7.	No Function	No Function, Water Side Economizer, Electric Heat W1, Electric Heat W2, Hot Water Valve W1, Hot Water Valve W2, Cycle w/ Fan, Cycle w/ Compressor, Source Water Valve, VFD Enable, Fan G3 (CT ECM)
Output Configuration Status — Checks the validity of the output configurations. Ensures one or more outputs are not configured for the same function.	—	Invalid, Valid

Table 23 – Unit Configuration (cont)

POINT NAME/DESCRIPTION	DEFAULT	RANGE
<i>i-Vu® / Field Assistant Navigation: Properties → Control Program → Configuration → Unit Configuration</i>		
SENSOR CALIBRATION		
Space Temperature — Displays the current space air temperature.	—	–35 to 240°F
Space Temp Calibration — A calibration offset value to allow the space temperature sensor to be adjusted to match a calibrated standard measuring the temperature in the same location.	0°F	–9.9 to 10°F
Supply Air Temperature — Displays the current supply air temperature.	—	–35 to 240°F
Supply Air Temp Calibration — A calibration offset value to allow the supply air temperature sensor to be adjusted to match a calibrated standard measuring the temperature in the same location	0°F	–9.9 to 10°F
Return Air Temperature — Displays the current return air air temperature.	—	–35 to 240°F
Return Air Temp Calibration — A calibration offset value to allow the return air temperature sensor to be adjusted to match a calibrated standard measuring the temperature in the same location.	0°F	–9.9 to 10°F
Entering Source Water Temperature — Displays the current entering source water air temperature.	—	–35 to 240°F
Entering Src Water Temp Calibration — A calibration offset value to allow the entering source water temperature sensor to be adjusted to match a calibrated standard measuring the temperature in the same location.	0°F	–9.9 to 10°F
Leaving Source Water Temperature — Displays the current Leaving source water air temperature.	—	–35 to 240°F
Leaving Src Water Temp Calibration — A calibration offset value to allow the leaving source water temperature sensor to be adjusted to match a calibrated standard measuring the temperature in the same location.	0°F	–9.9 to 10°F

Table 24 – Service Configuration

POINT NAME/DESCRIPTION	DEFAULT	RANGE
<i>i-Vu® / Field Assistant Navigation: Properties → Control Program → Configuration → Service Configuration</i>		
Reversing Valve Type — The reversing valve's signal output type	O	O / B
Source Water Valve Control — The source water valve control being used.	Modulating	2 Pos / Modulating
Fan Status Indicator Amps — The value the fan amperage must exceed to indicate a valid ON status.	0.5 A	0 to 10 A
Compressor Status Indicator Amps — The value the fan amperage must exceed to indicate a valid ON status.	2 A	0 to 10 A
Water Flow Status Indicator GPM — The value the flow rate must exceed to indicate a valid FLOW status.	0.5 gpm	0 to 10 gpm
Supply Fan Low Speed Setting — The low speed value for VFD fan type (UO1).	50%	0 to 66%
Supply Fan Medium Speed Setting — The medium speed value for VFD fan type (UO1).	66%	50 to 80%
Supply Fan High Speed Setting — The high speed value for VFD fan type (UO1).	100%	70 to 100%
Low Fan Speed % Duty Cycle — The low speed value for CA ECM fan type (UO1).	50%	7.5 to 66%
Medium Fan Speed % Duty Cycle — The medium speed value for CA ECM fan type (UO1).	66%	50 to 80%
High Fan Speed % Duty Cycle — The high speed value for CA ECM fan type (UO1).	95%	70 to 100%
Aux Heat Control — Determines how the auxiliary heat output is used. When set to Auxiliary Heat , it supplements the reverse cycle heating, as required or in cooling only units, maintains CTRL temp. If configured as Boilerless , Aux Heat is only used if the compressor failure alarm is active or the source water temperature is insufficient to operate reverse cycle heating.	Auxiliary Heat	Boilerless / Auxiliary Heat

Table 24 – Service Configuration (cont)

POINT NAME/DESCRIPTION	DEFAULT	RANGE
<i>i-Vu® / Field Assistant Navigation: Properties → Control Program → Configuration → Service Configuration</i>		
<p>Aux Heat PID — This BACnet Object determines what the leaving supply air setpoint target should be. Configuration > Service Configuration > Auxiliary Type must be set to Modulating or 2-Position.</p> <p>NOTE: The following default values should be changed only by a technician trained in PID Loop algorithms.</p> <p>Action reverse Update Interval 0:01 (mm:ss) Proportional 1 Integral 0.15 Derivative 0 Deadband 3 Bias 0</p>	—	—
2 Pt Pwr Connect for Aux Eheat — Determines if external power is used for any form of auxiliary electric heat.	Yes	No / Yes
Ventilation Damper Control — The ventilation damper control being used.	2-Pos	2-Pos / DCV
Min Setpoint Separation — Minimum separation that must be maintained between the heating and cooling setpoints.	5°F	2 to 10°F
Min Source Water Temp Heating — Determines the minimum source water temperature before the unit starts heating.	50°F	25 to 60°F
Max Source Water Temp Heating — Determines the maximum source water temperature before the unit starts heating.	80°F	65 to 100°F
Min Source Water Temp Cooling — Determines the minimum source water temperature before the unit starts cooling.	50°F	30 to 60°F
Max Source Water Temp Cooling — Determines the maximum source water temperature before the unit starts cooling.	105°F	85 to 120°F
Fluid Type — The type of condenser fluid.	Water	Water / Ethylene Glycol / Propylene Glycol
Fluid % — The percentage of the non-water fluid that is either ethylene glycol or propylene glycol.	5%	5 to 50%
Fan Current Min Input (V) — The minimum voltage output of the fan current monitor.	0-v	0 to 10-v
Fan Current Max Input (V) — The maximum voltage output of the fan current monitor.	10-v	0 to 10-v
Fan Current @ Min V — The amperage value that corresponds to the minimum voltage.	0 A	0 to 10 A
Fan Current @ Max V — The amperage value that corresponds to the maximum voltage.	10 A	0 to 10 A
Compressor Current Min Input (V) — The minimum voltage output of the compressor current monitor.	0-v	0 to 10-v
Compressor Current Max Input (V) — The maximum voltage output of the compressor current monitor.	10-v	0 to 10-v
Compressor Current @ Min V — The amperage value that corresponds to the minimum voltage.	0 A	0 to 10 A
Compressor Current @ Max V — The amperage value that corresponds to the maximum voltage.	10 A	0 to 10 A
Water Meter Min Input (V) — The minimum voltage output of the water meter.	0-v	0 to 10-v
Water Meter Max Input (V) — The maximum voltage output of the water meter.	10-v	0 to 10-v
Water Meter @ Min V — The flow rate that corresponds to the minimum voltage.	0 gpm	0 to 20 gpm
Water Meter @ Max V — The flow rate that corresponds to the maximum voltage.	20 gpm	0 to 100 gpm
<p>Sensor Binder — Use the Associated Sensors table to configure the Rnet to use additional ZS or wireless sensors.</p> <ul style="list-style-type: none"> • Network Type — Set to Rnet • Address — Enter the DIP switch settings that are on the additional ZS sensors (up to 5 total) or Rnet ID assigned to each wireless sensor in Sensor Builder • Lock Display — Check to make the sensor display only 	<p>(Index) - 1</p> <p>Network Type - Rnet</p> <p>Address - 1</p>	<p>(Index) - 1 to 5</p> <p>Network Type - Rnet</p> <p>Address - 1 to 5</p>

Table 24 – Service Configuration (cont)

POINT NAME/DESCRIPTION	DEFAULT	RANGE
<i>i-Vu® / Field Assistant Navigation: Properties → Control Program → Configuration → Service Configuration</i>		
Zone Temp — Configure additional ZS or wireless temperature sensors used on the WSHP. <ul style="list-style-type: none"> Use — Check to include ZS or wireless sensors' value in the Combined Algorithm (Average) is the default). Raw Value — Displays sensed temperature for each ZS or wireless temperature sensor's address Calibration — If needed, enter value to adjust the Corrected Value from the Raw Value, in order to calibrate an individual ZS or wireless sensor's sensed value. Combination Algorithm — Use Average, Maximum, or Minimum zone temperature to calculate the Corrected Value for temperature 	(Index) Area - (1) Main Sensor Use - checked Calibration - 0 Combination Algorithm - Average Input Smoothing - None Show on Sensors - Calculated Value Display Resolution - 1 COV Increment - .1	—
Zone Humidity — Configure additional ZS or wireless humidity sensors used on the WSHP. <ul style="list-style-type: none"> Use — Check to include ZS or wireless sensors' value in the Combined Algorithm (Maximum is the default). Raw Value — Displays sensed humidity for each ZS or wireless humidity sensor's address Calibration — If needed, enter value to adjust the Corrected Value from the Raw Value, in order to calibrate an individual ZS or wireless sensor's sensed value. Combination Algorithm — Use Average, Maximum, or Minimum ZS or wireless humidity to calculate the Corrected Value for humidity control. 	(Index) Area - (1) Main Sensor Use - unchecked Calibration - 0 Combination Algorithm - Maximum Input Smoothing - None Show on Sensors - Calculated Value Display Resolution - 1 COV Increment - 1	—
ZS Zone CO₂ — Configure additional ZS CO ₂ sensors used on the WSHP. <ul style="list-style-type: none"> Use — Check to include ZS sensors' value in the Combined Algorithm (Maximum is the default). Raw Value — Displays sensed CO₂ for each ZS CO₂ sensor's address Calibration — If needed, enter value to adjust the Corrected Value from the Raw Value, in order to calibrate an individual ZS sensor's sensed value. Combination Algorithm — Use Average, Maximum, or Minimum ZS CO₂ to calculate the Corrected Value for CO₂ control. 	(Index) Area — (1) Main ZS Sensor Use — unchecked Calibration — 0 Combination Algorithm — Maximum Input Smoothing — Medium Show on Sensors — Calculated Value Display Resolution — 1 COV Increment — 10	—
System Space Temperature — The network space temperature value that the controller is using for control (if applicable).	-999.00°F	—
System Setpoint Adjustment — The space temperature setpoint adjustment value received over the network.	-999.00°F	-5 to 5°F
System Space RH — Allows using another controller's relative humidity value over the network. The remote controller must be equipped with a network-accessible relative humidity sensor value.	-999%	2 to 100%
System Space AQ — Allows this controller to use a CO ₂ value from another controller over the network. The remote controller must be equipped with a network-accessible CO ₂ /IAQ sensor value.	-999 ppm	300 to 9999 ppm
System Cool Demand Level — The system cool demand level being received over the network.	0	0 to 3
System Heat Demand Level — The system heat demand level being received over the network.	0	0 to 3
System Outdoor Air Temperature — The OAT received over the network.	-999.00°F	—
System Occ Standby (t24) — The status of the occupied standby input received over the network.	On	On / Off
System Presence Sensor — The status of the presence sensor received over the network.	On	On / Off
System Standby Offset Motion — The status of the standby offset motion detector received over the network.	On	On / Off
SERVICE TEST		
Service Test — Enable to stop automatic control so you can test the controller's outputs. Automatically resets to Disable after 1 hour.	Disable	Disable / Enable
Fan Test — Enable to test the controller's fan speeds. Sequences fan from low to high speed and operates at each speed for 1 minute. Resets to Disable when complete. Service Test must be set to Enable.	Disable	Disable / Enable

Table 24 – Service Configuration (cont)

POINT NAME/DESCRIPTION	DEFAULT	RANGE
<i>i-Vu® / Field Assistant Navigation: Properties → Control Program → Configuration → Service Configuration</i>		
Fan / Speed — The commanded state of the supply fan.	—	Off Low Med High
Compressor Test — Enable to test compressor cooling and heating operation. Sequences cooling stage 1, then stage 2, then heating stage 2 and reduces capacity to stage 1. Operates each step for 1 minute. Resets to Disable when complete. Service Test must be set to Enable.	Disable	Disable / Enable
Compressor Test Mode — Displays which mode is being tested by the Compressor Test function.	—	Heating Cooling Inactive Dehumid TG Wait
Dehumidification Test — Enable to test the controller's dehumidification mode. Runs for 2 minutes in test mode, then resets to Disable when complete. Service Test must be set to Enable.	Disable	Disable / Enable
Aux Heat Test — Enable to test the auxiliary output. The fan is sequenced on and enables the aux heating coil to maximum for 1 minute. Aux Heat Test resets to Disable when complete. Service Test must be set to Enable.	Disable	Disable / Enable
Economizer Test — Enable to test the water loop economizer output. The fan is sequenced on and the water economizer valve is commanded open for 1 minute. Economizer Test resets to Disable when complete. Service Test must be set to Enable.	Disable	Disable / Enable
Preload OA Damper — Enable to drive the OA Damper 7.5% open. The installer should secure the damper shaft to the actuator with the damper in the fully closed position at this time. This assures a tight seal when the damper is in the closed position. Service Test must be set to Enable.	Disable	Disable / Enable
Open Vent Damper 100% — Enable to test the OA Damper output. During the test, the damper is driven slowly to the 100%, or fully open, position. You must perform the Preload OA Damper Position test before this test and set Service Test to Enable.	Disable	Disable / Enable

SEQUENCE OF OPERATION

Scheduling

Time periods must be configured to schedule the transitions from occupied to unoccupied operation. The time periods control the space temperature to occupied heating and cooling setpoints. The unit operates continuously in the Occupied mode until a time schedule is configured or a third-party control system enables/disables the BAS On/Off point. The local time and date for these functions must be set to operate properly. The occupancy source can be changed to one of the following:

OCCUPANCY

The TV-WSHPs operation depends upon its occupancy state (occupied/unoccupied). The TV-WSHP operates continuously in the Occupied mode until you configure an occupancy schedule.

An occupancy schedule may be:

- A local schedule configured in the controller using an Equipment Touch interface or Field Assistant interface
- A BACnet schedule configured for the TV-WSHP in the i-Vu® application.

To set up occupancy schedules, see the documentation for your user interface.

NOTE: A BACnet® schedule, downloaded from the i-Vu® application will overwrite a local schedule that was set up with an Equipment Touch interface or Field Assistant interface.

OCCUPANCY SOURCE - THE FOLLOWING SETTINGS DETERMINE OCCUPANCY.

Options:

- Always Occupied - (default) Controller operates continuously, regardless of any configured schedule
- BACnet Schedule - Uses a local BACnet occupancy schedule configured within the controller
- BAS On/Off - Occupancy is set over the network by another device or a third-party BAS.
- Remote Occ Input - Controller monitors an input contact connected to one of the available binary inputs configured to receive it. You must set Unit Configuration > Occupancy Source to Remote Occ Input and one Input Switch Configuration to Remote Occupancy.

IMPORTANT: Scheduling can only be controlled from one source.

Fire/Smoke/Emergency Shutdown Input

The TV-WSHP can read the status of an optional Emergency Shutdown contact input to determine if a fire or smoke detector alarm is present. If the controller determines an alarm condition is present, the unit is shutdown. The switch is factory-set to Normally closed and can be changed.

Shutdown Input

The TV-WSHP controller has a shutdown input (software point) which, when set to its Active mode causes the WSHP to safely shutdown in a controlled fashion. Heating and cooling is disabled after any minimum runtime conditions expire and the fan is disabled after the fan-off timer expires. All alarms are reset but any active alarm remains active. After the shutdown input transitions from Active mode to Inactive, the unit restarts after the configured power fail restart delay expires.

Indoor Fan Operation

You can configure the indoor fan to operate in any one of 3 Fan Modes:

- Auto - intermittent operation during both occupied and unoccupied periods
- Continuous (default) - intermittent operation during unoccupied periods and continuous during occupied periods
- Always on - operates the fan continuously during both occupied and unoccupied periods

In the Continuous default mode, the fan is turned on when any one of the following is true:

- It is in occupied mode, which is determined by the occupancy status.
- There is a demand for cooling or heating in the unoccupied mode.
- There is a call for dehumidification (optional).

When power is reapplied after a power outage, there is a configurable delay of 0-600 seconds (default 180) before starting the fan. You must configure the fan delay:

- The Fan On Delay defines the delay time (0-30 seconds, default 10) before the fan begins to operate after heating or cooling is started.
- The Fan Off Delay defines the delay time (0-180 seconds, default 90) the fan continues to operate after heating or cooling is stopped.

NOTE: The fan continues to run if the compressors, heating stages, or the dehumidification are on. If the control temp sensor failure alarm, supply air temp sensor failure alarm, or condensate overflow alarm is active, the fan is shut down immediately, regardless of occupancy state or demand.

Automatic Fan Speed Control

The TV-WSHP can control up to 3 fan speeds which are automatically determined by the output configurations. The TV-WSHP operates at the lowest speed possible to provide quiet and efficient fan operation with the best latent capability. The motor increases speed if additional cooling or heating is required to reach the desired control temperature setpoint. The control increases the motor's speed (if applicable) as the control temperature rises above the cooling or below the heating setpoint. The amount of control temperature increase above or below the setpoint required to increase the fan speed is configurable in the setpoint. Also, the control increases the fan speed as the Supply Air Temperature approaches the configured minimum or maximum limits.

Fan Speed Control

- During heating (HP units only) - When heat is required and active, the control continuously monitors the supply air temperature to verify it does not rise above the configured Maximum Heating SAT Limit (100°F default). As the SAT approaches this value, the control increases the fan speed as required to ensure the SAT remains within the limit. This provides the most quiet and efficient operation by running the fan at the lowest speed possible.
- During cooling - When mechanical cooling is required and active, the control continuously monitors the supply air temperature to verify it does not fall below the configured Minimum Cooling SAT Limit (50°F default). As the SAT approaches this value, the control increases the fan speed as required to ensure the SAT will remain within the limit. Fan operates at the lowest speed during dehumidification to maximize latent capacity during cooling.

Fan Status

The TV-WSHP provides an optional fan current input or a fan status input. If configured as fan current input, the status is proven when amps > 0.5 (default). The controller compares the status of the fan to the desired commanded state. When the fan is commanded to run (ON), the fan status is checked and verified to match the commanded state. If the fan status is not on, then a fan status alarm is generated after 1 minute and the equipment's compressor(s) and auxiliary heat is disabled and the optional OA damper closes.

Cooling Operation

The TV-WSHP Open operates 1 or 2 stages of cooling (up to 2 compressors or 1 compressor with 2 speeds) to maintain the desired cooling setpoint. The number of stages is configured automatically based upon output configurations. The compressor outputs are controlled by the PI (Proportional-integral) cooling loop and cooling stages capacity algorithm. The algorithm calculates the desired number of stages needed to satisfy the space by comparing the control temperature to the appropriate cooling setpoint.

NOTE: The waterside economizer, if applicable, is used for first stage cooling, in addition to the compressor(s).

The following conditions must be true for the cooling algorithm to run:

- Cooling is set to Enable.
- The Fire/Smoke Input and Shutdown modes are inactive.
- Heat mode is not active, and the compressor time guard(s) have expired.
- Condensate Overflow input in normal.
- Fan Status is true (optional).
- If occupied, the control temperature is greater than the occupied cooling setpoint.
- Control and supply air temperature readings are valid.
- If unoccupied, the control temperature is greater than the unoccupied cooling setpoint.
- If economizer cooling is available and active, and the economizer alone is insufficient to provide enough cooling.
- OAT > Cooling Lockout Temperature if OAT is available.
- Source water temperatures are within operating parameters and flow status (if available) is proven for 120 sec (default) via flow switch or water meter.

If all the above conditions are met, the compressors' relays are energized as required. Otherwise, they will be de-energized. If cooling is active and if the SAT approaches the minimum SAT limit, the fan will be indexed to the next higher speed. If this is insufficient, and if the SAT falls further (equal to the minimum SAT limit), the fan will be indexed to the maximum speed. If the SAT still continues to fall 5°F below the minimum SAT limit, all cooling stages will be disabled.

During cooling (HP units only), the reversing valve output is held in the cooling position (either B or O type, as configured), even after the compressor is stopped. The valve does not switch position until the heating mode is required.

The configuration screens contain the Min SAT parameter as well as Cooling Lockout based on outdoor air temperature (OAT). Both can be adjusted to meet various specifications.

There is a 5-minute off-time for the compressor, as well as a 5-minute time delay, when staging up to allow the SAT to achieve a stable temperature, before energizing a second stage of capacity. Likewise, there is a 45 second delay when staging down.

After a compressor is staged off, it may be restarted again after a normal time-guard period of 5 minutes and if the supply air temperature has increased above the minimum supply air temperature limit.

The TV-WSHP provides an optional compressor current input or a compressor status input. If configured as compressor current input, the status is proven when amps > 2 (default). The status is monitored to determine if the compressor status matches the commanded state. This input is used to determine if a refrigerant safety switch or other safety device has tripped and caused the compressor to stop operating normally. If this occurs, an alarm is generated to indicate the faulted compressor condition. If compressor status is not configured, the TV-WSHP receives the compressor status from the UPM board via a serial connection.

Heating Operation

The TV-WSHP operates 1 or 2 stages of compression to maintain the desired heating setpoint. The number of stages is configured automatically based upon output configurations. The compressor outputs are controlled by the heating PI (Proportional-integral) loop and heating stages capacity algorithm. The algorithm calculates the desired number of stages needed to satisfy the space by comparing the control to the appropriate heating setpoint.

The following conditions must be true for the heating algorithm to run:

- Heating is set to Enable.
- The Fire/Smoke Input and Shutdown modes are inactive.
- Cool mode is not active, and the compressor time guard(s) have expired.
- Condensate Overflow input in normal.
- Fan Status is true.
- If occupied, the control temperature is less than the occupied heating setpoint.
- Control and supply air temperature readings are valid.
- If unoccupied, the control temperature is less than the unoccupied heating setpoint
- OAT > Heating Lockout Temperature if OAT is available.
- Source water temperature are within operating parameters and flow status (if available) is proven for 120 sec (default) via flow switch or water meter.

If all the above conditions are met, the heating outputs are energized as required, otherwise they are de-energized. If the heating is active and the SAT approaches the maximum SAT limit, the fan is indexed to the next higher speed. If this is insufficient, and if the SAT rises further and reaches the Maximum Heating SAT limit, the fan is indexed to the maximum speed. If the SAT still continues to rise 5°F above the maximum limit, all heating stages are disabled.

During Heating (HP units only), the reversing valve output is held in the heating position (either B or O-type, as configured), even after the compressor is stopped. The valve does not switch position until the cooling mode is required.

The configuration screens contain the Max SAT parameter as well as heating lockout based on outdoor air temperature (OAT). Both can be adjusted to meet various specifications.

There is a 5-minute off-time for the compressor, as well as a 5-minute time delay, when staging up to allow the SAT to achieve a stable temperature before energizing a second stage of capacity (optional). Likewise, a 45-second delay is used when staging down.

Source Water Valve

The TV-WSHP provides modulating or 2-position control for an optional source water valve. The following conditions must be true for the source water valve algorithm to run otherwise the valve is closed:

- Compressor or waterside economizer is called to run.
- The entering and leaving condenser water temperatures are valid.
- Fan status is true.

Modulating Source Water Valve

When called, the valve opens to 50% minimum and then modulates to maintain a source water differential temperature setpoint. In the cool mode, the differential setpoint is 10°F (adj.). In heat mode, the setpoint is set as 75% (adj.) of the cool mode setpoint. If there is a condenser water temperature alarm, the valve stops modulating and is opened to 20% to allow circulation of water until the temperatures normalize. This valve can also be configured for 2-position control.

2-Position Source Water Valve

When called, the valve fully opens.

Auxiliary Heat

The TV-WSHP can control a modulating water valve, up to 2 stages of electric/hydronic heat, or SCR heat depending on output configurations. If Aux Heat Control is configured for boilerless control operation, the aux heat only operates if a compressor failure occurs, or the source water temperature is insufficient for reverse cycle heating. If Aux Heat Control is configured for Auxiliary Heat, in addition to the above, it also operates to supplement the heat provided by the compressor, if the control temperature falls more than 1°F below the desired heating setpoint. (This amount is configurable.) The heat is controlled so the SAT does not exceed the Maximum Heating SAT limit.

AUXILIARY MODULATING HOT WATER / SCR HEATING

The control can modulate a hot water valve/SCR to maintain the desired heating setpoint if the compressor capacity is insufficient or a compressor failure occurs. Unless a compressor fault condition exists, the hot water valve/SCR only operates to supplement the heat provided by the compressor if the space temperature falls more than 1°F below the desired heating setpoint. The hot water valve/SCR is controlled so the SAT does not exceed the Maximum Heating SAT limit.

STAGED ELECTRIC/HYDRONIC HEAT

The control can operate up to 2 stages of electric/hydronic heat in order to maintain the desired heating setpoint if the compressor capacity is insufficient or a compressor failure occurs. Unless a compressor fault condition exists, the hot water valve/staged electric heat supplements the heat provided by the compressor, if the control temperature falls more than 1°F below the desired heating setpoint. The staged electric heat/hydronic is controlled so the SAT does not exceed the Maximum Heating SAT limit and is subject to a 2-minute minimum OFF-time to prevent excessive cycling.

If the unit is configured for any form of electric heat and Auxiliary Heat is selected as control, external power must be provided for that option. If external power is not provided, then the electric heat will run only if mechanical compression is not active due to power limitations.

Indoor Air Quality (IAQ) and Demand Control Ventilation (DCV)

If the ZS CO₂ (IAQ), or the System Space AQ network input point is used, the TV-WSHP maintains indoor air quality with a modulating OA damper, which provides demand-controlled ventilation. The control operates the modulating OA damper during occupied periods, monitors the CO₂ level, compares it to the configured setpoints, and adjusts the ventilation rate, as required. The control provides proportional ventilation to meet the requirements of ASHRAE specifications by providing a base ventilation rate and then increasing the rate as the CO₂ level increases. The control proportionally increases ventilation when the CO₂ level rises above the start ventilation setpoint and reaches the full ventilation rate when the CO₂ level is at or above the maximum setpoint. You can configure a minimum damper position to ensure that proper base ventilation is delivered when occupants are not present. Access the IAQ configurations through the Configuration screen.

The following conditions must be true for this algorithm to run:

- Damper Control is configured for DCV.
- The Fire/Smoke Input and Shutdown modes are inactive.
- Fan Status is true.
- The unit is in an occupied mode.
- IAQ sensor reading is greater than the DCV Start CTRL Setpoint.

The control has the following 4 adjustable setpoints:

- DCV Start Ctrl Setpoint
- DCV Max Ctrl Setpoint
- Vent Dmpr Pos / DCV Min Pos
- DCV Max Vent Damper Pos

NOTE: In order for the damper to maintain proper base ventilation, you must configure the fan as Continuous or Always On.

2-Position OA Damper

You can configure the TV-WSHP to operate as a ventilation damper in a 2-position ventilation mode to provide the minimum ventilation requirements during occupied periods.

Dehumidification

The TV-WSHP provides occupied and unoccupied dehumidification on units that are equipped with the HGRH option. This function requires a valid space relative humidity reading via a ZS Humidity Sensor or a network input point System Space RH.

When the indoor relative humidity becomes greater than the dehumidification setpoint and there is no demand for heat or cooling, a dehumidification demand is initiated, bringing on the supply fan, mechanical cooling, and hot gas reheat coil. The controls engage cooling mode and the waste heat from the compressor cooling cycle is returned to the hot gas reheat coil simultaneously.

Modulating Hot Gas Reheat

The valve modulates to maintain a HGRH SA setpoint. As control temp fluctuates between the heating and cooling setpoint, it is proportionally converted to a HGRH SA setpoint value between the Maximum Heating SAT and Minimum Cooling SAT.

On/Off Hot Gas Reheat

The valve fully opens when in dehumidification mode.

NOTE: There is a 5-minute delay when the unit switches between dehumidification, cooling and heating mode.

Waterside Economizer

The TV-WSHP can provide modulating, or 2-position water economizer control.

The following conditions must be true for economizer operation:

- If occupied, the control temperature is greater than the occupied cooling setpoint or less than the occupied heating setpoint and the source water is suitable
- If unoccupied, the control temperature is greater than the unoccupied cooling setpoint, or less than the unoccupied heating setpoint, and the source water is suitable
- Flow status (if available) is proven via flow switch or water meter.

COOLING

Cooling provides an economizer cooling function by using the water loop when the entering water loop temperature is at least 5°F below control temperature. If the water loop conditions are suitable, the valve modulates open to maintain a Supply Air Temperature that meets the load conditions. If the economizer coil capacity alone is insufficient for a period greater than 5 minutes, or if a high humidity condition occurs, then the compressor starts, in order to satisfy the load. If the SAT approaches the Minimum

Cooling SAT limit, the economizer valve modulates closed during compressor operation.

HEATING

In addition, the control modulates the water valve if the entering source water loop temperature is suitable for heating (at least 5°F above control temperature) and heat is required. The valve is controlled in a similar manner, except to satisfy the heating requirement. If the coil capacity alone is insufficient to satisfy the space load conditions for more than 5 minutes, then the compressor starts in order to satisfy the load. If the SAT approaches the Maximum Heating SAT limit, the economizer valve modulates closed during compressor operation.

Demand Limiting

The TV-WSHP can accept 3 levels of demand limit from the BACnet® network. In response to a demand limit, the unit decreases its heating setpoint and increases its cooling setpoint to widen the range, in order to immediately lower the electrical demand. You can configure the temperature adjustment for both heating and cooling and for each demand level. You can also set the response to a particular demand level to 0.

Power Failure Restart Delay

The TV-WSHP provides a delay when recovering from a power failure, a shutdown mode, or when transitioning from unoccupied to occupied mode, in order to prevent excessive demand when many units start simultaneously. Each unit can be configured for a unique delay between 0 and 600 seconds. The factory-programmed default delay is 180 seconds.

Alarms

EMERGENCY SHUTDOWN (FIRE/SMOKE)

The control monitors a discrete input to determine the state of an emergency shutdown contact. If the input is in the ON state at any time, an alarm is generated after 3 seconds and the equipment (fan, compressor, aux heat, and damper) immediately shuts down.

UNIT HARD LOCKOUT (UPM)

This alarm indicates the unit is in a Hard Lockout condition from the UPM board.

ZS SENSOR

This alarm indicates a communication failure of a connected ZS sensor that had previously been actively communicating. The alarm is reset when normal ZS sensor communications resume, if power is cycled to the controller.

ZS CONFIGURATION

This alarm indicates that at least 1 ZS sensor is configured in the Sensor Binder properties and is not communicating. The alarm is reset when the configured ZS sensor is communicating, or the configuration is changed to reflect the sensor is no longer connected to the Rnet.

SPACE TEMP SENSOR

This alarm indicates an invalid sensor reading from the Network, T55 or ZS sensor. The alarm is reset once it detects a valid reading.

CTRL TEMP SENSOR FAILURE

This alarm indicates an invalid sensor reading for the temperature used for control (RAT, Space Temperature). The unit is shut down until the alarm is reset. The alarm is reset once it detects a valid reading.

SPACE TEMPERATURE ALARMS

The TV-WSHP provides the ability to generate an alarm when the space temperature exceeds the alarm setpoint. A separate occupied hysteresis and fixed unoccupied high and low alarm setpoints are provided. The control provides a 5-minute alarm delay during

unoccupied periods. During occupied periods, the control uses the occupied temperature setpoint and applies the hysteresis value to determine the alarm setpoints. When occupancy transitions from unoccupied to occupied or the occupied temperature setpoints are changed, causing an alarm condition to occur, the control automatically calculates an alarm delay (equivalent to the configured delay time in minutes/ °F, multiplied by the temperature error, + 15 minutes). This prevents nuisance alarms when an occupancy change occurs and allows time for the unit to correct an alarming temperature condition.

SOURCE WATER TEMPERATURE ALARM

The TV-WSHP has 4 configurable alarm limits for source water temperature. The control verifies that the water temperature is within operating range (between high and low limits) for the specific operating mode (heating or cooling) before energizing the compressor. Once the compressor is started, the source water temperature is further monitored to verify that it is within limits to ensure sufficient water is flowing through the coil. If the leaving water temperature rises above or falls below the appropriate limits, and lasts for more than 15 seconds, an alarm is generated, and the compressor shuts down.

SOURCE WATER DELTA TEMPERATURE ALARM

The TV-WSHP has 4 configurable alarm limits for source water delta temperature. The source water delta temperature is calculated as the absolute value of the difference between entering source water temperature and leaving source water temperature. The control verifies that the source water delta temperature is within operating range (between high and low limits) when the unit is operating in heating or cooling mode. If the air temperature rises above or falls below the appropriate limits, and lasts for more than 5 minutes, an alarm is generated.

SUPPLY AIR TEMPERATURE ALARM

The TV-WSHP has 2 configurable alarm limits for supply air temperature. The control verifies that the supply air temperature is within operating range (between high and low limits) when the unit is operating. If the air temperature rises above or falls below the appropriate limits, and lasts for more than 5 minutes, an alarm is generated.

SUPPLY TEMPERATURE SENSOR FAILURE

This alarm indicates an invalid supply air temp reading. The unit is shut down until the alarm is reset. The alarm is reset once it detects a valid reading.

RETURN AIR TEMPERATURE ALARM

TV-WSHP has 2 configurable alarm limits for return air temperature. The control verifies the return air temperature is within operating range (between high and low limits) when the unit is operating. If the air temperature rises above or falls below the appropriate limits, and lasts for more than 5 minutes, an alarm is generated.

RETURN TEMPERATURE SENSOR FAILURE

This alarm indicates an invalid return air temp reading. The alarm is reset once it detects a valid reading.

AIRSIDE DELTA TEMPERATURE ALARM

The TV-WSHP has 4 configurable alarm limits for airside delta temperature. The airside delta temperature is calculated as the absolute value of the difference between supply air temperature and return air temperature. The control verifies that the airside delta temperature is within operating range (between high and low limits) when the unit is operating in heating or cooling mode. If the air temperature rises above or falls below the appropriate limits, and lasts for more than 5 minutes, an alarm is generated.

SECONDARY CONDENSATE OVERFLOW ALARM

The TV-WSHP monitors a discrete input to determine the state of a secondary condensate level switch. If this input is in an alarm state, the control starts a timer, and after the timer exceeds a

configurable Condensate Overflow Alarm Delay limit (10 second default), the control generates an alarm, and the unit disables the compressor and fan outputs.

PRIMARY CONDENSATE OVERFLOW ALARM (UPM)

The alarm indicates a primary condensate overflow condition from the UPM board.

SUPPLY FAN FAILURE

The TV-WSHP generates a supply fan failure alarm if the fan status is not proven via dry contact or current reading any fan speed output has been enabled. A 30 second alarm delay is used to allow the fan to start operation before an alarm condition is detected. The control monitors the fan output and if the fan is operating at any speed, the fan status must be proven.

COMPRESSOR STATUS ALARM(S)

The TV-WSHP generates a compressor failure alarm if the compressor status is not proven via dry contact, current reading or via UPM board after the compressor output has been energized. A 6-minute alarm delay is used to allow the compressor to start (prevents alarms due to time guard operation) before an alarm condition is detected. The control monitors the compressor output and if the compressor output is energized, compressor status must be detected. For units with 2 compressors, status on proven only via the UPM board.

FILTER STATUS ALARM

The TV-WSHP provides the ability to generate a dirty filter alarm after the number of fan run hours exceeds a configurable filter alarm timer limit. The control monitors the fan output and if the fan is operating at any speed, it accumulates run time. If the fan run time hours exceed the configurable limit, an alarm is generated. To reset the alarm timer after the alarm has been generated, a Reset Filter Alarm input is provided. You can disable the filter alarm by setting the Filter Alarm Timer Delay to 0 (factory default).

INDOOR AIR QUALITY ALARM

The TV-WSHP provides the ability to generate a high CO₂ level alarm during occupied periods when the CO₂ sensor value exceeds the adjustable limit. When a transition from unoccupied to occupied occurs, or the occupied alarm limit is changed to a value that causes an alarm condition to occur, the control will automatically calculate an alarm delay (equivalent to the configured delay time in minutes/ppm, times the error that occurred, +15 minutes). This prevents nuisance alarms from occurring when occupancy changes or the setpoint is changed. You can disable the IAQ alarm by setting Occupied High IAQ Alarm Limit to 0.

CO₂ SENSOR FAILURE

This alarm indicates an invalid sensor reading for the indoor air quality used for DCV control (Network IAQ, ZS IAQ). The unit is shut down until the alarm is reset. The alarm is reset once it detects a valid reading.

RELATIVE HUMIDITY ALARM

The TV-WSHP provides the ability to generate an alarm when the space relative humidity exceeds the alarm setpoint. Separate occupied and unoccupied high humidity alarm setpoints are provided. The control provides a 5-minute alarm delay during unoccupied periods. During occupied periods, the controller uses the occupied high RH alarm limit. When an occupancy transition from unoccupied to occupied occurs, or the occupied high alarm limit is lowered, causing an alarm condition to occur, the control automatically calculates an alarm delay (equivalent to the configured delay time in minutes/% RH, times the humidity error condition that occurred, +15 minutes). This prevents nuisance alarms when an occupancy change occurs and allows time for the unit to correct an alarming humidity condition.

OUTDOOR AIR TEMPERATURE SENSOR ALARM

The alarm indicates a valid OAT sensor value is no longer available to the controller after having been available previously. The alarm is reset once it detects a valid reading.

OA DAMPER ALARM

This alarm indicates the feedback is $\pm 5\%$ (adj.) of the commanded position of the OA damper. (ACT Net only).

SOURCE WATER VALVE ALARM

This alarm indicates the feedback is $\pm 5\%$ (adj.) of the commanded position of the source water valve (ACT Net only).

WATER ECONOMIZER ALARM

This alarm indicates the feedback is $\pm 5\%$ (adj.) of the commanded position of the water economizer damper (ACT Net only).

LOW WATER FLOW ALARM

The TV-WSHP provides the ability to monitor a flow switch or water meter reading indicating condenser water flow. If a compressor/water economizer is called to run and condenser water flow is not proven within 2 minutes (adj.), an alarm is generated.

SOURCE WATER LINKAGE

This alarm, when active, indicates a Source Water Linkage Failure. This alarm is enabled to be operational once a valid Source Water Linkage connection is established.

INPUT CONFIGURATION

The TV-WSHP generates this alarm when Input 7 and 8 are configured for the same function. The alarm clears and normal control is restored when the input function duplication is corrected. Unit will not run while in Alarm.

OUTPUT CONFIGURATION

The TV-WSHP generates this alarm when one or more of the outputs is configured for the same function. The alarm clears and normal control is restored when the input function duplication is corrected. Unit will not run while in Alarm.

Zone Environmental Index

The TV-WSHP uses Environmental Index (EI) to calculate a real-time numerical EI value for a zone based on ideal Occupied space temperature, optional relative humidity (RH) and/or CO₂. Environmental Index determines the source(s) derating the EI value by continuously evaluating Occupied zone conditions. EI Decreased By displays the source(s) derating the EI value. The EI Space Temp Setpoint Tolerance 0.5°F (0.28°C) is subtracted from Effective Heat Setpoint and is added to Effective Cool Setpoint, expanding the ideal EI temperature sensitivity range. The EI is derated from the initial Occupied value of 100% if the space temperature deviates from the ideal EI temperature sensitivity range.

NOTE: The EI Space Temp Setpoint Tolerance does not affect the controlling space temperature Effective Heat Setpoint or Effective Cool Setpoint.

The optional RH and/or CO₂ values derate the EI value when they deviate from their setpoints.

- If a valid RH sensor is detected, EI is derated when RH value is less than EI Humidity Low Limit or when RH value is greater than the Occupied RH Control Setpoint.
- If DCV Control is configured, EI is derated by CO₂ if the value exceeds the DCV Max Ctrl Setpoint.

If a zone is Unoccupied, the EI will calculate a value of 0%.

EI Time Satisfied is the percentage of Occupied time which a zone maintains an EI value of 70% or higher.

Weighted EI determines the priority of a zone in an EI roll-up, which must be completed using a different control program. The value is determined by multiplying the real-time EI value by the EI Weighting Factor.

APPENDIX A – BACNET® POINTS LIST

Table A – BACnet Points List

POINT NAME	POINT ACCESS	UNITS	DEFAULT VALUE	BACnet POINT NAME	BACnet OBJECT ID
Cooling Occupied Setpoint	R/W	°F	76	occ_cl_stpt	AV:3001
Heating Occupied Setpoint	R/W	°F	70	occ_ht_stpt	AV:3002
Cooling Unoccupied Setpoint	R/W	°F	90	unocc_cl_stpt	AV:3003
Heating Unoccupied Setpoint	R/W	°F	55	unocc_ht_stpt	AV:3004
Aux Heat Boiler Water Temp	R	°F	—	link_hwt	AV:2702
Aux Heat Control Setpoint	R	°F	—	aux_heat_stpt	AV:3014
Auxiliary Heat Ctrl Output	R	%	—	aux_heat_output	AV:2021
Clg Src Water Diff Stpt	R/W	°F	10	src_wtr_diff_clg	AV:2036
Compressor Capacity	R	%	—	comp_cap	AV:5001
Comp Runtime Stage 1 (UPM)	R	hrs	—	comp_run_stg1	AV:6122
Comp Runtime Stage 2 (UPM)	R	hrs	—	comp_run_stg2	AV:6222
Comp Start Requests Stage 1 (UPM)	R	—	—	start_req_stg1	AV:6118
Comp Start Requests Stage 2 (UPM)	R	—	—	start_req_stg2	AV:6218
Comp Starts Stage 1 (UPM)	R	—	—	starts_stg1	AV:6120
Comp Starts Stage 2 (UPM)	R	—	—	starts_stg2	AV:6220
Controlling Temperature - Prime Variable	R	°F	—	ctrl_temp	AV:2035
Cooling OAT Lockout Temp	R/W	°F	45	oat_cl_lockout	AV:9002
Current Fault Status Stage 1 (UPM)	R	—	—	flt_status_stg1	AV:6105
Current Fault Status Stage 2 (UPM)	R	—	—	flt_status_stg2	AV:6205
Dehum Ctrl Output	R	%	—	hgrh_heat_output	AV:2029
Effective Cool Setpoint	R	°F	—	eff_cl_stpt	AV:3005
Effective Heat Setpoint	R	°F	—	eff_ht_stpt	AV:3006
Effective Src Water Diff Stpt	R	°F	—	src_wtr_diff_eff	AV:3008
Entering SrcW Temp	R	°F	—	cwe_temp	AV:1020
Fan Off Delay	R/W	sec	90	fan_delay_off	AV:9024
Fan On Delay	R/W	sec	10	fan_delay_on	AV:9025
Filter Runtime	R	hrs	—	filter_rntm	AV:2015
Filter Service Alarm Timer	R/W	hrs	600	filter_service_hrs	AV:2019
Freeze 1 Temp Stage 1 (UPM)	R	°F	—	freeze1_stg1	AV:6123
Freeze 1 Temp Stage 2 (UPM)	R	°F	—	freeze1_stg2	AV:6223
Freeze 2 Temp Stage 1 (UPM)	R	°F	—	freeze2_stg1	AV:6124
Freeze 2 Temp Stage 2 (UPM)	R	°F	—	freeze2_stg2	AV:6224
Hard Lockout Status Stage 1 (UPM)	R	—	—	hd_lock_stg1	AV:6104
Hard Lockout Status Stage 2 (UPM)	R	—	—	hd_lock_stg2	AV:6204
Heating OAT Lockout Temp	R/W	°F	65	oat_ht_lockout	AV:9003
Htg Src Water Diff Stpt	R	°F	—	src_wtr_diff_htg	AV:2046
Htg Src Water Diff Stpt as % Clg Stpt	R	°F	—	src_wtr_diff_per	AV:2047
Indoor Air Quality CO ₂ (ppm)	R	ppm	—	iaq	AV:1009
Leaving SrcW Temp	R	°F	—	cwl_temp	AV:1017
Loop Pump Request	R	0 (Off) / 1 (On)	—	loop_request	AV:2024
Maximum Heating SAT	R/W	°F	110	sat_ht_max	AV:83004
Minimum Cooling SAT	R/W	°F	50	sat_cl_min	AV:83003
OA Damper Ctrl Output	R	%	—	oad_output	AV:2022
Occ Override Delay	R/W	min	15	occ_ovr_delay	AV:9028
Occ Relative Humidity Setpoint	R/W	%rh	60	occ_dehum_stpt	AV:3011
Occupied Standby Delay (T24)	R/W	min	5	os_delay_mins	AV:9054
Occupied Standby Offset (T24)	R/W	°F	2	os_stpt_offset	AV:9053
Optimal Start	R/W	hrs	1	optm_start	AV:9026
Outdoor Air Temperature	R	°F	—	oa_temp	AV:1003
Power Fail Restart Delay	R/W	sec	180	start_delay	AV:9007

APPENDIX A – BACNET® POINTS LIST (cont)

Table A – BACnet Points List (cont)

POINT NAME	POINT ACCESS	UNITS	DEFAULT VALUE	BACnet POINT NAME	BACnet OBJECT ID
Remaining Occupied Standby Delay (T24)	R	min	—	os_delay_rem	AV:9058
Return Air Temperature	R	°F	—	ra_temp	AV:1010
Running Soft Lockouts Stage 1 (UPM)	R	—	—	run_sf_lock_stg1	AV:6116
Running Soft Lockouts Stage 2 (UPM)	R	—	—	run_sf_lock_stg2	AV:6216
Setpoint Adjustment	R	°F	—	stpt_adj	AV:1006
Setpoint Adjustment Range	R/W	°F	5	stpt_adj_range	AV:9015
Soft Lockouts Stage 1 (UPM)	R	—	—	sf_lock_stg1	AV:6106
Soft Lockouts Stage 2 (UPM)	R	—	—	sf_lock_stg2	AV:6206
Space Relative Humidity	R	%rh	—	space_rh	AV:1011
Space Temperature	R	°F	—	space_temp	AV:2007
Standby Offset	R/W	°F	0	stdby_offset	AV:1033
Supply Air Temperature	R	°F	—	sa_temp	AV:1008
System Configuration Stage 1 (UPM)	R	—	—	sys_config_stg1	AV:6103
System Configuration Stage 2 (UPM)	R	—	—	sys_config_stg2	AV:6203
System Cooling Demand Level	R	—	—	cool_demand_level	AV:9006
System Heating Demand Level	R	—	—	heat_demand_level	AV:9036
System Outdoor Air Temperature	R/W	°F	-999	system_oat	AV:1901
System Setpoint Adjustment	R/W	°F	-999	system_stpt_adj	AV:1913
System Space AQ	R/W	ppm	-999	system_iaq	AV:1903
System Space RH	R/W	%rh	-999	system_rh	AV:1904
System Space Temperature	R/W	°F	-999	system_spt	AV:1902
T55 Override Duration	R/W	hrs	1	ovr_dur	AV:9023
Test AO-2	R/W	%	0	ao_two	AV:91008
Test AO-3	R/W	%	0	ao_three	AV:91009
Test UO-1	R/W	%	0	uo_one	AV:91010
Unocc Relative Humidity Setpoint	R/W	%rh	90	unocc_dehum_stpt	AV:3012
Unoccupied High SPT Alarm Limit	R/W	°F	95	uno_spt_alm_hi_lmt	AV:9016
Unoccupied Low SPT Alarm Limit	R/W	°F	45	uno_spt_alm_lo_lmt	AV:9017
UPM Firmware Version Stage 1 (UPM)	R	—	—	firm_ver_stg1	AV:6101
UPM Firmware Version Stage 2 (UPM)	R	—	—	firm_ver_stg2	AV:6201
Vent Dmpr Pos / DCV Min Pos	R/W	%	20	econ_min	AV:4005
Water Economizer Control Setpoint	R	°F	—	h2o_econ_ctrl_stpt	AV:3015
Water Economizer Output	R	%	—	h2o_econ_output	AV:2023
Water Loop Temp	R	°F	—	link_cwt	AV:2701
Water Meter	R	GPM	—	water_flow	AV:2042
Aux Heat HW Pump Status	R	Off (0) / On (1)	—	hw_pump	BV:2703
Compressor Contactor Status Stage 1 (UPM)	R	—	—	contact_status_stg1	BV:6105
Compressor Contactor Status Stage 2 (UPM)	R	—	—	contact_status_stg2	BV:6205
Primary Condensate Status (UPM)	R	—	—	condensate_status	BV:6104
Cool Enable	R/W	Disable (0) / Enable (1)	Enable (1)	cl_enable	BV:1011
Dehumidification	R	Inactive (0) / Active (1)	—	dehum	BV:2006
DIP SW(1) Lockout Switch Stage 1 (UPM)	R	2 (0) / 4 (1)	—	lck_sw_1stg_1	BV:6106
DIP SW(1) Lockout Switch Stage 2 (UPM)	R	2 (0) / 4 (1)	—	lck_sw_1stg_2	BV:6206
DIP SW(2) Reset Switch Stage 1 (UPM)	R	Y (0) / R (1)	—	reset_sw_2stg_1	BV:6107
DIP SW(2) Reset Switch Stage 2 (UPM)	R	Y (0) / R (1)	—	reset_sw_2stg_2	BV:6207

APPENDIX A – BACNET® POINTS LIST (cont)

Table A – BACnet Points List (cont)

POINT NAME	POINT ACCESS	UNITS	DEFAULT VALUE	BACnet POINT NAME	BACnet OBJECT ID
DIP SW(3) Alarm Switch Stage 1 (UPM)	R	Pulse (0) / Continuous (1)	—	alm_sw_3stg_1	BV:6108
DIP SW(3) Alarm Switch Stage 2 (UPM)	R	Pulse (0) / Continuous (1)	—	alm_sw_3stg_2	BV:6208
DIP SW(4) Test Switch Stage 1 (UPM)	R	No (0) / Yes (1)	—	test_sw_4stg_1	BV:6109
DIP SW(4) Test Switch Stage 2 (UPM)	R	No (0) / Yes (1)	—	test_sw_4stg_2	BV:6209
DIP SW(5) Freeze 1 Switch Stage 1 (UPM)	R	25°F (0) / 15°F (1)	—	frz_sw_5stg_1	BV:6110
DIP SW(5) Freeze 1 Switch Stage 2 (UPM)	R	25°F (0) / 15°F (1)	—	frz_sw_5stg_2	BV:6210
DIP SW(6) Freeze 2 Switch Stage 1 (UPM)	R	25°F (0) / 15°F (1)	—	frz2_sw_6stg_1	BV:6111
DIP SW(6) Freeze 2 Switch Stage 2 (UPM)	R	25°F (0) / 15°F (1)	—	frz2_sw_6stg_2	BV:6211
Emergency Shutdown Status	R	Off (0) / On (1)	—	emerg_shtdwn_status	BV:2011
Enable CEC Title 24 (T24)	R/W	Disable (0) / Enable (1)	Disable (0)	ena_t24	BV:9050
Factory Test	R/W	Disable (0) / Enable (1)	Disable (0)	fac_test_enable	BV:91000
Flow	R	Off (0) / On (1)	—	flow	BV:1005
Flow Switch Input	R	No Flow (0) / Flow (1)	—	flow_sw_status	BV:1002
Heat Enable	R/W	Disable (0) / Enable (1)	Enable (1)	ht_enable	BV:1012
HPS Status Stage 1 (UPM)	R	High Pressure Fault (0) / Normal (1)	—	hps_status_stg1	BV:6102
HPS Status Stage 2 (UPM)	R	High Pressure Fault (0) / Normal (1)	—	hps_status_stg2	BV:6202
Inhibit Occupied Standby from this zone? (T24)	R/W	No (0) / Yes (1)	No (0)	os_inhib	BV:9052
Loop Pump Status	R	Off (0) / On (1)	—	loop_pump	BV:2702
LPS Status Stage 1 (UPM)	R	Low Pressure Fault (0) / Normal (1)	—	lps_status_stg1	BV:6103
LPS Status Stage 2 (UPM)	R	Low Pressure Fault (0) / Normal (1)	—	lps_status_stg2	BV:6203
Occupancy Contact	R	Inactive (0) / Active Occupied (1)	—	occ_contact_status	BV:1020
Occupancy Status	R	Unoccupied (0) / Occupied (1)	—	occ_status	BV:2008
Occupied Standby (T24)	R/W	Disable (0) / Enable (1)	Disable (0)	occ_stndby	BV:9051
Occupied Standby Delay (T24)	R	Inactive (0) / Active Occupied (1)	—	os_delay	BV:9057
Reset Filter Alarm	R/W	Off (0) / On (1)	Off (0)	filter_rntm_clr	BV:7517
Reversing Valve Type	R/W	O (0) / B (1)	O (0)	rev_vlv_type	BV:99005
Secondary Condensate Overflow	R	Off (0) / On (1)	—	overflow_sw_status	BV:1001
Setpoint Adjustment	R/W	Disable (0) / Enable (1)	Enable (1)	stpt_adj_enable	BV:1013
Shutdown	R/W	Inactive (0) / Active (1)	Inactive (0)	shutdown	BV:9001
Source Water Linkage	R	Not Active (0) / Active (1)	—	cw_link_status	BV:2701
Source Water Valve	R	Close (0) / Open (1)	—	src_vlv_otpt_bv	BV:1021
Src Water Valve Ctrl Output	R	%	—	src_vlv_otpu_av	AV:2048
Supply Fan Status	R	Off (0) / On (1)	—	sfan_status	BV:1003
Test DO-2	R/W	Off (0) / On (1)	Off (0)	do_two	BV:91002
Test DO-3	R/W	Off (0) / On (1)	Off (0)	do_three	BV:91003
Test DO-4	R/W	Off (0) / On (1)	Off (0)	do_four	BV:91004
Test DO-5	R/W	Off (0) / On (1)	Off (0)	do_five	BV:91005
Test DO-6	R/W	Off (0) / On (1)	Off (0)	do_six	BV:91006
Test DO-7	R/W	Off (0) / On (1)	Off (0)	do_seven	BV:91007
Water Economizer	R	Inactive (0) / Active (1)	—	h2o_econ_output_bo	BV:2027
Y Call Stage 1 (UPM)	R	No Call (0) / Call (1)	—	y_call_stg1	BV:6101
Y Call Stage 2 (UPM)	R	No Call (0) / Call (1)	—	y_call_stg2	BV:6201
BAS On / Off	R/W	Inactive (1) / Occupied (2) / Unoccupied (3)	Inactive (1)	keypad_ovrde	MSV:1001
Ctrl Temp Source	R	Sensor Failure (1) / Space (2) / Return Air (3) / Locked Value (5)	—	ctrl_temp_src	MSV:2013

APPENDIX A – BACNET® POINTS LIST (cont)

Table A – BACnet Points List (cont)

POINT NAME	POINT ACCESS	UNITS	DEFAULT VALUE	BACnet POINT NAME	BACnet OBJECT ID
Current Fault Stage 1 (UPM)	R	No Fault (1) / HPC Fault (2) / LPC Fault (3) / Freeze 1 Fault (4) / Condensate Fault (5) / Brownout Fault (6) / Freeze 2 Fault (7) / Refrig Sensor Fault (8) / HPC1 Fault (9) / LPC1 Fault (10) / HPC2 Fault (11) / LPC2 Fault (12) / Freeze 1 Fault (13) / Condensate Fault (14) / Brownout Fault (15) / Freeze 2 Fault (16) /	—	cur_ft_stg1	MSV:6100
Current Fault Stage 2 (UPM)	R	Same as Current Fault Stage 1 (UPM)	—	cur_ft_stg2	MSV:6200
Fan / Speed	R	Off (1) / Low (2) / Medium (3) / High (4) / On (5)	—	fan_run	MSV:2004
Hard Lockout Stage 1 (UPM)	R	Same as Current Fault Stage 1 (UPM)	—	hd_lk_stg1	MSV:6101
Hard Lockout Stage 2 (UPM)	R	Same as Current Fault Stage 1 (UPM)	—	hd_lk_stg2	MSV:6201
Occupancy Source	R/W	Always Occupied (1) / BACnet Schedule (2) / BAS OnOff (3) / Remote Occ Input (4)	Always Occupied (1)	occ_source	MSV:1002
Occupied Standby Mode (T24)	R	Inactive (1) / Fan Off (2) / Heating (4) / Cooling (5) / Fan Running (6)	—	occ_stndby_status	MSV:9055
Occupied Standby Source (T24)	R	Sensor Failure (1) / Local (2) / Network (3) / ZS Sensor (4) / Locked Value (5)	—	os_snsd_occ_source	MSV:9056
Optimal Start Type	R/W	None (1) / Temp Compensated (2) / Learning Adaptive (3)	None (1)	start_type	MSV:2009
Shutdown Reason	R	Normal Operation (1) / CTRL Temp Sensor Fail (2) / SAT Sensor Fail (3) / Condensate Overflow (4) / Hard Lockput UPM (5) / Emergency Shutdown (6)	—	shtdown_reason	MSV:1004
Space Temp Source	R	Not Available (1) / T55 (3) / Network (4) / Locked Value (6) / ZS Sensor (7)	—	spt_status	MSV:2003
System Mode	R	Off (1) / Fan Only (2) / Economize (3) / Cooling (4) / Heating (5) / Continuous Fan (6) / Test (7) / Start Delay (8) / Dehumidify (9) / Emerg. Shutdown (10) / Manual Shutdown (11) / IAQ Override (12) / I/O Config Error (13)	—	run_status	MSV:2002
Ventilation Damper Control	R/W	2-Pos (1) / DCV (2)	2-Pos (1)	dpr_type	MSV:91002
Airside Delta T Alarm	R	Normal (0) / Alarm (1)	—	airdeltat_alm	BV:7034
CO₂ Sensor Failure	R	Normal (0) / Alarm (1)	—	co2_fail	BV:7024
Compressor 1 Status	R	Normal (0) / Alarm (1)	—	comp1_alarm	BV:7013
Compressor 2 Status	R	Normal (0) / Alarm (1)	—	comp2_alarm	BV:7014
Cooling Source Water Temperature	R	Normal (0) / Alarm (1)	—	cool_cwt_alarm	BV:7088
Ctrl Temp Sensor Failure	R	Normal (0) / Alarm (1)	—	ctrl_temp_fail	BV:7067
Emergency Shutdown	R	Normal (0) / Alarm (1)	—	emergency_alarm	BV:7007
Filter	R	Normal (0) / Alarm (1)	—	filter_alarm	BV:7017
Heating Source Water Temperature	R	Normal (0) / Alarm (1)	—	heat_cwt_alarm	BV:7027
High Space Temperature	R	Normal (0) / Alarm (1)	—	spt_hi_alarm	BV:7011
Indoor Air Quality	R	Normal (0) / Alarm (1)	—	iaq_alarm	BV:7005
Input Configuration	R	Normal (0) / Alarm (1)	—	inpt_cfg_alarm	BV:7025
Low Space Temperature	R	Normal (0) / Alarm (1)	—	spt_lo_alarm	BV:7012
Low Water Flow	R	Normal (0) / Alarm (1)	—	low_flow_alarm	BV:7026

APPENDIX A – BACNET® POINTS LIST (cont)

Table A – BACnet Points List (cont)

POINT NAME	POINT ACCESS	UNITS	DEFAULT VALUE	BACnet POINT NAME	BACnet OBJECT ID
OA Damper Alarm	R	Normal (0) / Alarm (1)	—	sa_oad_alarm	BV:7030
Outdoor Air Temp Sensor	R	Normal (0) / Alarm (1)	—	oat_fail	BV:7029
Output Configuration	R	Normal (0) / Alarm (1)	—	otpt_cfg_alarm	BV:7070
Primary Condensate Overflow (UPM)	R	Normal (0) / Alarm (1)	—	pri_overflow_alarm_mb	BV:7040
Return Air Temperature Alarm	R	Normal (0) / Alarm (1)	—	rat_alarm	BV:7035
Return Temp Sensor Failure	R	Normal (0) / Alarm (1)	—	ra_temp_fail	BV:7071
Secondary Condensate Overflow	R	Normal (0) / Alarm (1)	—	overflow_alarm	BV:7028
Source Water Linkage	R	Normal (0) / Alarm (1)	—	cond_water_linkage_fail	BV:7031
Space Relative Humidity	R	Normal (0) / Alarm (1)	—	sprh_hi_alarm	BV:7018
Src Water Valve Alarm	R	Normal (0) / Alarm (1)	—	sv_src_water_alarm	BV:7032
SrcW Delta T Alarm	R	Normal (0) / Alarm (1)	—	srcwdeltat_alm	BV:7033
Supply Air Temperature Alarm	R	Normal (0) / Alarm (1)	—	sat_alarm	BV:7004
Supply Fan Failure	R	Normal (0) / Alarm (1)	—	sfan_fail_alarm	BV:7008
Supply Temp Sensor Failure	R	Normal (0) / Alarm (1)	—	sa_temp_fail	BV:7069
Unit Hard Lockout	R	Normal (0) / Alarm (1)	—	hard_lck_out_alarm_mb	BV:7041
Water Economizer Alarm	R	Normal (0) / Alarm (1)	—	sv_wse_alarm	BV:7036
ZS Sensor Configuration	R	Normal (0) / Alarm (1)	—	zs_config_fail	BV:7055
ZS Temp Sensor	R	Normal (0) / Alarm (1)	—	zst_sensor_fail	BV:7051

APPENDIX B – WIRING DIAGRAMS

FACTORY INSTALLED COMPONENTS (OUTPUTS):

- UO-1 - UNIVERSAL OUTPUT 1:
 G1 - FAN ON (PSC & CT ECM)
 ECM - FAN MODULATION (CA ECM PWM)
 VFD - FAN MODULATION (VFD 0-10VDC)

AO-2 - ANALOG OUTPUT 2:

- MRV - MODULATING REHEAT VALVE

BO-2 - BINARY OUTPUT 2:

- Y1 - COMPRESSOR

BO-3 - BINARY OUTPUT 3:

- O - REVERSING VALVE

BO-4 - BINARY OUTPUT 4:

- Y2 - COMPRESSOR (TWO STAGE/SPEED)
 WSE - WATER-SIDE ECONOMIZER VALVE (SINGLE STAGE)
 W1 - AUX HEAT 1ST STAGE (SINGLE STAGE)

BO-5 - BINARY OUTPUT 5:

- H - DEHUMIDIFICATION (HGRH)
 W1 - AUX HEAT 1ST STAGE (SINGLE OR TWO STAGE/SPEED)

BO-6 - BINARY OUTPUT 6:

- G2 - FAN ON (CT ECM)
 WSE - WATER-SIDE ECONOMIZER VALVE (TWO STAGE)
 W2 - AUX HEAT 2ND STAGE (TWO STAGE/SPEED)

BO-7 - BINARY OUTPUT 7:

- G3 - FAN ON (CT ECM)
 VFD - VFD ENABLE/DISABLE

STANDARD FACTORY INSTALLED COMPONENTS (INPUTS):

- IN-2 - UNIVERSAL INPUT 2:
 LWTS - LEAVING WATER TEMPERATURE SENSOR

IN-3 - UNIVERSAL INPUT 3:

- EWTS - ENTERING WATER TEMPERATURE SENSOR

STANDARD FACTORY PROVIDED COMPONENTS (INPUTS):

- IN-1 - UNIVERSAL INPUT 1:
 SATS - SUPPLY AIR TEMPERATURE SENSOR

IN-6 - UNIVERSAL INPUT 6:

- RATS - RETURN AIR TEMPERATURE SENSOR

OPTIONAL FACTORY INSTALLED COMPONENTS (INPUTS):

- IN-7 - UNIVERSAL INPUT 7:
 DPS - DIFFERENTIAL PRESSURE SWITCH

OPTIONAL FIELD INSTALLED COMPONENTS (INPUTS):

- IN-6 - UNIVERSAL INPUT 6:
 SPT - SPACE TEMPERATURE SENSOR

IN-7 OR 8 - UNIVERSAL INPUT 7 OR 8:

- EMSD - EMERGENCY SHUTDOWN
 OCC - REMOTE OCCUPANCY
 SCO - SECONDARY CONDENSATE OVERFLOW
 FS - FLOW SWITCH
 FM - WATER FLOW METER

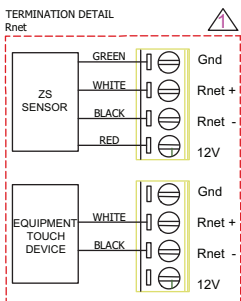
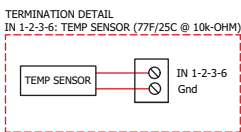
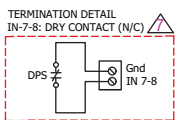

FACTORY WIRE _____
 FIELD WIRE - - - - -

- ⚠ EQUIPMENT TOUCH DEVICE OR OPTIONAL ZS COMBINATION WALL SENSOR CAPABLE OF TEMPERATURE, HUMIDITY, AND CO2 READINGS.
- ⚠ OPTIONAL MODULATING REHEAT VALVE (MRV)
- ⚠ **TWO STAGE/SPEED UNITS:** BO-4 IS ONLY AVAILABLE FOR OUTPUT SIGNAL (Y2)
SINGLE STAGE/SPEED UNITS: BO-4 IS AVAILABLE FOR WSE
- ⚠ H SIGNAL IS USED ON REHEAT APPLICATIONS
- ⚠ **TWO STAGE/SPEED UNITS:** BO-6 IS AVAILABLE FOR WSE OUTPUT SIGNAL
SINGLE STAGE/SPEED UNITS: BO-6 IS AVAILABLE FOR FAN ON G2 OUTPUT SIGNAL
- ⚠ IN-07 UTILIZED FOR OPTIONAL FACTORY INSTALLED DIFFERENTIAL PRESSURE FLOW SWITCH WHEN EQUIPPED

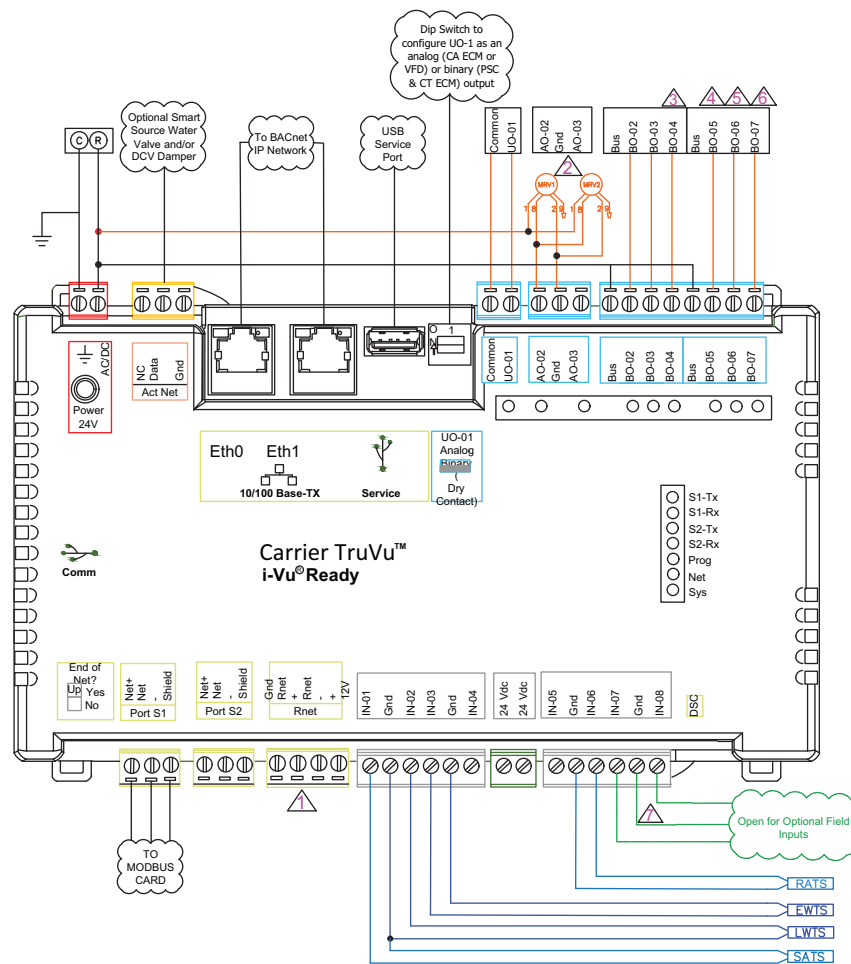

8733837662 Rev 2

Fig. A – TruVu™ Controller for Water-Source Heat Pumps

APPENDIX C — EQUIPMENT TOUCH NAVIGATION AND WIZARD

Initial Setup

1. On the **'Home'** screen select the **'Login'** icon (Key Hole) and enter the factory password. See the Equipment Touch Installation Guide for password.
2. Select the **'Menu'** icon (Gold Gear).
3. On the **'Menu'** screen select the **'Startup'** icon (Key Chain). The **'Startup'** icon will navigate to the **'Unit Type'** screen which will have a base configuration preset from the factory.
4. Follow the intuitive self guided setup process and complete each startup screen.
5. On the **'Summary'** screens review the configuration settings.
6. On the **'Save'** screen, set to Yes to write configuration to controller

Field Installed Options

Initial setup must be completed and saved to the controller prior to configuring field installed options.

1. On the **'Home'** screen select the **'Login'** icon (Key Hole) and enter the factory password. See the Equipment Touch Installation Guide for password.
2. Select the **'Menu'** icon (Gold Gear).
3. On the **'Menu'** screen select the **'Startup'** icon (Key Chain). The **'Startup'** icon will navigate to the **'Unit Type'** screen.
4. Set **'Unit Type'** to **'Custom.'**
5. Navigate through the startup screens to configure the controller for the field installed options.
6. On the **'Summary'** screens review the configuration settings.

7. On the **'Save'** screen, set to Yes to write configuration to controller.

Unconfigured/Replacement

1. On the **'Home'** screen select the **'Login'** icon (Key Hole) and enter the factory password. See the Equipment Touch Installation Guide for password.
2. Select the **'Menu'** icon (Gold Gear).
3. On the **'Menu'** screen select the **'Startup'** icon (Key Chain). The **'Startup'** icon will navigate to the **'Unit Type'** screen.
4. Set **'Unit Type'** to the appropriate base configuration for the unit. The **'Unit Type'** is initially shown as **'Unconfigured.'**
5. Follow the intuitive self guided setup process and complete each startup screen.
6. On the **'Summary'** screens review the configuration settings.
7. On the **'Save'** screen, set to Yes to write configuration to controller.

NOTE: If field installed options are required to be configured refer to **'Field Installed Options'** setup process.









NOTE: The JumpTo buttons (Unit, Fan, Htg, Clg, Summary) will become available to revisit a previous section as the setup process is progressing.

See Table B for further instructions and display examples.

<p>IMPORTANT: Engineering units shown in this document in the defaults and ranges are strictly for reference. You must enter an integer only.</p>
--



APPENDIX C – EQUIPMENT TOUCH NAVIGATION AND WIZARD (cont)

Table B – Quick Start for Configuration

SCREEN NAME	DISPLAY	DETAILS
STANDBY	 <p data-bbox="464 554 1057 577">Not an interactive screen, touch Home icon to advance to Home screen.</p>	<p data-bbox="1263 312 1471 380">Screen displays after the Inactivity Timer expires (default is 5 minutes).</p> <p data-bbox="1263 401 1510 506">Displays: Controlling Temperature Current Setpoints OA (outside air) Temperature Occupancy</p>
HOME	 <p data-bbox="516 911 1008 934">NOTE: Access is limited to certain depending on user level.</p>	<p data-bbox="1263 579 1471 646">Screen displays after the Inactivity Timer expires. (Default is 5 minutes).</p> <p data-bbox="1263 646 1471 793">Displays: Controlling Temperature Current Setpoints OA Temperature Occupancy Navigates to: Login</p> <div data-bbox="1328 814 1458 905">  </div> <p data-bbox="1263 905 1471 972">Log in as User, Admin, or Factory. Trends</p> <div data-bbox="1328 993 1458 1094">  </div> <p data-bbox="1263 1094 1341 1117">Setpoints</p> <div data-bbox="1328 1138 1458 1239">  </div> <p data-bbox="1263 1239 1500 1283">Must be logged in as Admin. Schedule</p> <div data-bbox="1328 1304 1458 1409">  </div> <p data-bbox="1263 1409 1325 1432">Alarms</p> <div data-bbox="1328 1451 1458 1556">  </div> <p data-bbox="1263 1556 1312 1579">Menu</p> <div data-bbox="1328 1598 1458 1703">  </div> <p data-bbox="1263 1703 1325 1726">System</p> <div data-bbox="1328 1745 1458 1850">  </div> <p data-bbox="1263 1850 1500 1873">Must be logged in as Admin.</p>

APPENDIX C – EQUIPMENT TOUCH NAVIGATION AND WIZARD (cont)

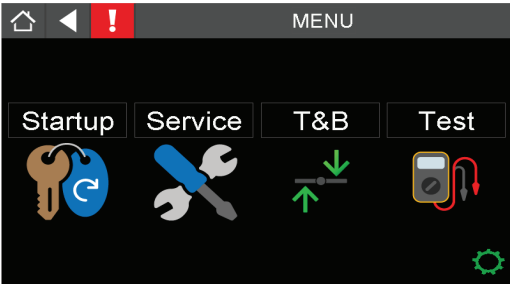
Table B – Quick Start for Configuration (cont)

SCREEN NAME	DISPLAY	DETAILS
<p>MENU</p>	 <p>Click on Startup to begin the configuration process.</p> <p>The new "Persona" design of the Equipment Touch files (Startup Wizard, Service Tech, T and B, Test) are designed to provide an intuitive self guided experience for the setup process by the technician. The process is designed to provide mistake proofing for the simplest experience to get the unit configured and running. The Startup Wizard uses rules for each product type and only offers allowed configurations and options for that factory unit. The unit may still be configured as always using Property Pages in i-Vu® or Field Assistant.</p>	<p>Startup - allows startup technician to configure unit for startup. The screens will intuitively guide the simplified/ abbreviated startup configuration of the unit.</p> <p>Service - allows service technician to access advanced configurations, calibrations, status, monitoring, etc. of the unit.</p> <p>T and B - allows the test and balance agent to access a simplified interface for T and B.</p> <p>Test - allows technician to utilize Service Test mode.</p> <p>Navigates to:</p> 

APPENDIX C – EQUIPMENT TOUCH NAVIGATION AND WIZARD (cont)

Table B – Quick Start for Configuration (cont)

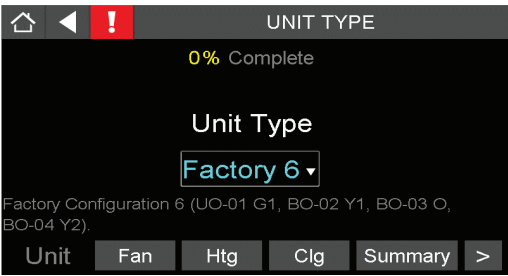
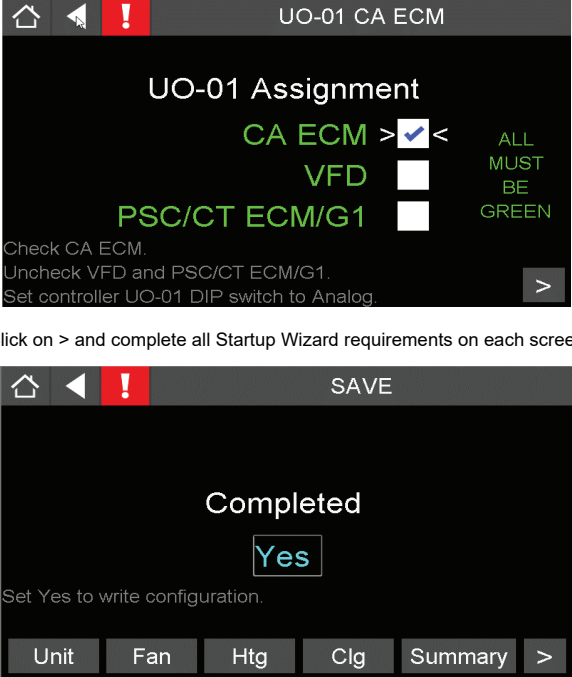
SCREEN NAME	DISPLAY	DETAILS
UNIT TYPE	<p> Factory 1 — Compression 1-Stage, Fan PSC, (UO-01 G1, BO-02 Y1, BO-03 O) Factory 2 — Compression 1-Stage, Fan CT ECM, (UO-01 G1, BO-02 Y1, BO-03 O, BO-06 G2, BO-07 G3) Factory 3 — Compression 1-Stage, Fan CA ECM, (UO-01 PWM, BO-02 Y1, BO-03 O) Factory 4 — Compression 2-Speed, Fan CA ECM, (UO-01 PWM, BO-02 Y1, BO-03 O, BO-04 Y2) Factory 5 — Compression 2-Circuit, Fan VFD, (UO-01 0-10VDC, BO-02 Y1, BO-03 O, BO-04 Y2, BO-07 VFD Enable) Factory 6 — Compression 2-Circuit, Fan 1-Speed, (UO-01 G1, BO-02 Y1, BO-03 O, BO-04 Y2) </p>  <p> LEGEND BO — Binary Output CA ECM — Constant Airflow Electronically Commutated Motor CT ECM — Constant Torque Electronically Commutated Motor Custom — Factory custom configuration G1 — Fan (single speed units) or Low Speed (3 speed units) G2 — Medium Speed (3 speed units) G3 — High Speed (3 speed units) O — Reversing Valve (heating default) PSC — Permanent Split Capacitor PWM — Pulse Width Modulation UO — Universal Output VFD — Variable Frequency Drive Y1 — Compressor 1 or Low Speed Compressor 1 Y2 — Compressor 2 or High Speed Compressor 1 </p>	<p>% Complete - Indicates progress of the Startup Wizard process.</p> <p>Unit Type - The type of unit the TV-WSHP is controlling.</p> <p>Click on > to navigate to the next screen below.</p> <p>If the unit is factory configured, the UO-01 assignment is already selected. If this is a factory unconfigured module, then the appropriate Fan type must be checked.</p>
	 <p>Click on > and complete all Startup Wizard requirements on each screen</p> <p>Once all the startup settings have been configured, set to Yes to write the TV-WSHP controller.</p>	

APPENDIX C – EQUIPMENT TOUCH NAVIGATION AND WIZARD (cont)

Source Water Linkage

Use this screen to set up Source Water Linkage using the following properties in Table C and Fig. B. To navigate to **Startup Wizard**, click on the bottom. See Table D for information on source water linkage.

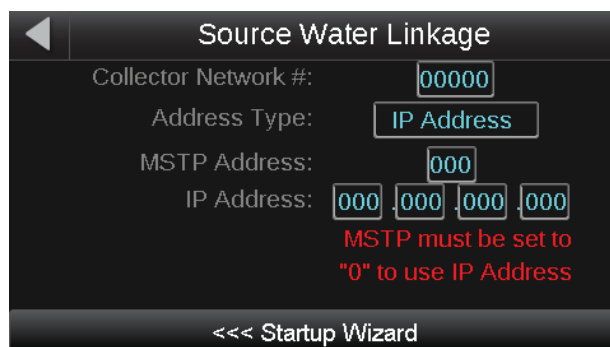

Set up Source Water Linkage using the following properties:

- Collector Network number.
- Address Type: (IP Address/MAC)
- MSTP Address of Collector.
- IP Address of Collector (to set an IP address, the MSTP address must be set to "0").

Fig. B – Source Water Linkage Startup Wizard

Table C – Startup Wizard Configuration

POINT NAME/DESCRIPTION	DEFAULT	RANGE
EQUIPMENT TOUCH START UP WIZARD		
Unit Type: The type of unit installed.	CV	CV, VAV
CV SF Low Speed Setting: The low fan speed setting in CV mode.	50%	0 to 100%
CV SF Med Speed Setting: The medium fan speed setting in CV mode.	66%	0 to 100%
CV SF High Speed Setting: The high fan speed setting in CV mode.	100%	0 to 100%
Min. VFD Output: The minimum allowed fan speed.	25%	0 to 100%
Max. VFD Output: The maximum allowed fan speed.	100%	0 to 100%
Enable SF Status Function: Allows the supply fan status to be used.	No	No, Yes
Enable CW Valve Status Function: Allows the CW valve status to be used.	No	No, Yes
CW DP Switch: Allows the CW DP switch to be used, if installed.	None	None, Installed
Reversing Valve: Allows the reversing valve to be used, if installed.	Installed	Installed, None
Auxiliary Heat Type: Allows the auxiliary heat to be used, if installed.	Installed	Installed, None – Cooling Only
Hot Gas Reheat: Allows the hot gas reheat to be used, if installed.	Modulating	Modulating, None
Entering Air H₂O Economizer: The water side economizer type.	None	None, 2-Pos
Vent Damper Type: The ventilation damper control being used.	None	None, 2-Pos, DCV
Hardwired Humidity Sensor: Set to Installed if a humidity sensor is present.	None	None, Installed
Compression Stages: The number of stages of compression.	Two Stages	Two Stages, Four Stages

Table D – Source Water Linkage

POINT NAME/DESCRIPTION	DEFAULT	RANGE
EQUIPMENT TOUCH START UP WIZARD		
SOURCE WATER LINKAGE		
Collector Network Number: Enter the source water controller's MSTP network number.	0	0 to 65,534
Address Type: Select the type of BACnet network of the source water controller.	MS/TP	MS/TP or IP Address ^a
MSTP Address: Set the MAC address of the source water controller. NOTE: The MSTP address and IP address are mutually exclusive. To set an IP address, the MSTP address must be 0.	0	0 to 99
IP Address: Set the MAC address of the source water controller. NOTE: The MSTP address and IP address are mutually exclusive. To set an IP address, the MSTP address must be 0.	0.0.0.0	0.0.0.0 to 255.255.255.255

NOTE(S):

- a. MS/TP is the default address type; however a BACnet IP address must still be configured unless a MS/TP router (TV-CRB-E2) is provided.

