



Installation Instructions

IMPORTANT: This installation instruction contains basic unit installation information including installation of field control devices. For information on unit start-up, service, and operation, refer to the unit Controls, Start-Up, Operation, Service, and Troubleshooting Instructions also enclosed in the unit literature packet.

CONTENTS

	Page
SAFETY CONSIDERATIONS	2
A2L REFRIGERATION INFORMATION	5
Transportation	5
Minimum Conditioned Space Area	5
GENERAL	7
PRE-INSTALLATION	7
Inspection	7
Unit Storage	7
Storage Guidelines	7
• DRY LOCATION	
• DRAINAGE	
• CONDENSATION PREVENTION	
• PROTECTION	
Temporary Operation for a Completed Building	7
Temporary Operation for an Under-Construction	7
INSTALLATION	7
Step 1 — Check Jobsite	7
• INSTALLATION GUIDELINES (ALL UNITS)	
Step 2 — Check Unit	9
• INSPECT UNIT	
Step 3 — Provide Unit Support	9
• ROOF CURB	
Step 4 — Rig and Place Unit	9
• LIFTING A PACKAGED DOAS	
• MOVING/LIFTING A PACKAGED AIR CONDITIONING UNIT	
• POSITIONING	
• ROOF MOUNT	
• SLAB MOUNT	
• INSTALLATION ONTO CURB	
Step 5 — Field Fabricate Ductwork	27
• DUCTWORK CONSIDERATIONS	
• RETURN AIR DUCTWORK	
• DISCHARGE DUCTWORK	
Step 6 — Make Unit Duct Connections	27
• VERTICAL SUPPLY/RETURN CONNECTIONS	
• HORIZONTAL SUPPLY CONNECTIONS	
Step 7 — Install External Trap for Evaporator Condensate Drain	27
Step 8 — Install Gas Piping (Gas Heat Units Only) 28	
• B, C, CL, AND D CABINETS	
• CXL, DXL CABINETS	
• GAS HEAT SAFETY CONTROLS	
Step 9 — Install Gas Heat Condensate Drain	29
Step 10 — Install Hot Water (Hot Water Units Only) .. 29	
• HOT WATER COIL PIPE ROUTING	
• HOT WATER HEATING CONTROL	
Step 11 — Make Electrical Connections	30
• OPTIONAL UNIT-POWERED TYPE CONVENIENCE OUTLET	
• OPTIONAL NON-UNIT-POWERED TYPE (FIELD WIRED) CONVENIENCE OUTLET	
• FIELD POWER SUPPLY	
• SENSOR WIRING	
• A2L REFRIGERANT LEAK DETECTION SYSTEM INTERLOCK	
Step 12 — Open Exhaust Damper (Units with Optional Exhaust or Energy Conservation Wheel Only) .. 32	
Step 13 — Install all Accessories	32
Step 14 — Configure Controls	32
• SEQUENCE OF OPERATION	
• OCCUPIED MODE	
• STAGED HEAT (ELECTRIC HEAT) 2-STAGE HEAT	
• STAGED HEAT (ELECTRIC HEAT) 4-STAGE HEAT	
• STAGED HEAT (GAS HEATER) 2-STAGE	
• STAGED HEAT (GAS HEATER) 4-STAGE	
• MODULATED HEAT	
• UNOCCUPIED MODE	
• SAFETY SHUTDOWN	
• REFRIGERANT CHARGING	
Step 15 — Unit Start-Up	35
Step 16 — Test Mode and Fan Balancing	35
Typical Wiring Diagrams	35
MAINTENANCE	46
Installation Code and Quarterly Inspections	46
General	46
• QUARTERLY	
Unit Exterior	46
• CABINET EXTERIOR	
• UNIT LOCATION	
Direct Drive Supply and Exhaust Fans	46
• BLOWER WHEEL	
• MOTORS	
Condensing Fans	46
Refrigeration Circuit Components	46
• INDOOR COIL	
• OUTDOOR COIL	
• COMPRESSORS	
Condensate Drain Pan and Drain	46
Dampers	46
• DAMPERS	
• DAMPER MOTOR/LINKAGES	
Energy Conservation Wheel	47
• OVERVIEW	
• MOISTURE TRANSFER	
• WHEEL COMPONENTS	

- CASSETTE SERIAL NUMBER IDENTIFICATION
- PRE-START-UP
- SET PURGE ANGLE (IF NECESSARY)
- POST-START-UP
- INSPECTION CHECKLIST
- CLEANING ENERGY RECOVERY WHEEL SEGMENTS
- SEGMENT REMOVAL/INSTALLATION

Gas Heater 54

- GAS LINE
- MANUAL SAFETY SHUT OFF VALVE
- DIRECT SPARK IGNITER
- GAS VALVE
- BURNERS
- HEAT EXCHANGER
- DRAFT INDUCER
- VENT PIPE/TERMINAL
- CONDENSATION DRAIN

Electric Heater Wiring and Wiring Connections 54

- CONTROL PANEL
- HEATING ELEMENTS

Filters 54

TROUBLESHOOTING 55

SAFETY CONSIDERATIONS





Improper installation, adjustment, alteration, service, maintenance, or use can cause explosion, fire, electrical shock, or other conditions which may cause death, personal injury, or property damage. Consult a qualified installer, service agency, or your distributor or branch for information or assistance. The qualified installer or agency must use factory-authorized kits or accessories when modifying this product. Refer to the individual instructions packaged with the kits or accessories when installing.

Follow all safety codes. Wear safety glasses, protective clothing, and work gloves. Have a fire extinguisher available. Read these instructions thoroughly and follow all warnings or cautions included in literature and attached to the unit. Affix any labels that ship with the unit or accessory installation instructions to the unit. Consult local building codes, the current editions of the National Fuel Gas Code (NFGC) NFPA 54/ANSI Z223.1, and the National Electrical Code (NEC)/National Fire Protection Association (NFPA) 70.

In Canada refer to the current editions of the National Standards of Canada CAN/CSA-B149.1 and 149.2 Natural Gas and Propane Installation Codes, and Canadian Electrical Code (CEC) CSA C22.1.

Recognize safety information. This is the safety-alert symbol . When you see this symbol on the unit and in instructions or manuals, be alert to the potential for personal injury. Understand the signal words DANGER, WARNING, and CAUTION. These words are used with the safety-alert symbol. DANGER identifies the most serious hazards which will result in severe personal injury or death. WARNING signifies hazards which could result in personal injury or death. CAUTION is used to identify unsafe practices which may result in minor personal injury or product and property damage. NOTE is used to highlight suggestions which will result in enhanced installation, reliability, or operation.

The following symbols may be seen on the equipment:

SYMBOL	CODE	MEANING
	GHS02: Flammable	Flammable gas
	ISO 7000-0790 (2004-01)	Read operator's manual.
	ISO 7000-1659 (2004-01)	Service indicator: read technical manual.
	ISO 7000-1641 (2004-01)	Operator's manual: operating instructions

IMPORTANT: Read the entire instruction manual before starting installation.

⚠ WARNING

Before performing service or maintenance operations on unit, turn off main power switch to unit. Electrical shock could cause personal injury.

AVERTISSEMENT

Avant d'effectuer des opérations d'entretien ou de maintenance sur l'appareil, coupez l'alimentation principale de l'appareil. Un choc électrique peut entraîner des blessures corporelles.

⚠ WARNING

FIRE, EXPLOSION HAZARD

Failure to follow this warning could result in death, serious personal injury and/or property damage.

Disconnect gas piping from unit when pressure testing at pressure greater than 0.5 psig (3450 Pa). Pressures greater than 0.5 psig will cause gas valve damage resulting in hazardous condition. If gas valve is subjected to pressure greater than 0.5 psig, it must be replaced before use. When pressure testing field-supplied gas piping at pressures of 0.5 psig or less, a unit connected to such piping must be isolated by closing the manual gas valve(s).

⚠ AVERTISSEMENT

RISQUE D'INCENDIE ET D'EXPLOSION

Le non-respect de cet avertissement peut entraîner la mort, des blessures graves et/ou des dommages matériels.

Débranchez la tuyauterie de gaz de l'appareil lors d'un essai de pression à une pression supérieure à 0,5 psig (3450 Pa). Une pression supérieure à 0,5 psig endommagera la valve de gaz et créera une situation dangereuse. Si la valve de gaz est soumise à une pression supérieure à 0,5 psig, elle doit être remplacée avant utilisation. Lors d'un essai de pression sur une tuyauterie de gaz fournie sur site à une pression inférieure ou égale à 0,5 psig, l'appareil raccordé à cette tuyauterie doit être isolé en fermant la ou les valves de gaz manuelles.

⚠ DANGER

Do not store or use gasoline or other flammable vapors and liquids in the vicinity of this or any other appliance.

⚠ DANGER

Ne stockez pas et n'utilisez pas d'essence ou d'autres vapeurs et liquides inflammables à proximité de cet appareil ou de tout autre appareil.

⚠ WARNING

RISK OF FIRE OR EXPLOSION

If the information in this manual is not followed exactly, a fire or explosion may result causing property damage, personal injury or loss of life.

Do not store or use gasoline or other flammable vapors and liquids in the vicinity of this or any other appliance.

WHAT TO DO IF YOU SMELL GAS

- Do not try to light any appliance.
- Do not touch any electrical switch; do not use any phone in your building.
- Leave the building immediately.
- Immediately call your gas supplier from a neighbor's phone. Follow the gas supplier's instructions.
- If you cannot reach your gas supplier, call the fire department.

Installation and service must be performed by a qualified installer, service agency or the gas supplier.

⚠ AVERTISSEMENT

RISQUE D'INCENDIE OU D'EXPLOSION

Si les consignes de sécurité ne sont pas suivies à la lettre, cela peut entraîner la mort, de graves blessures ou des dommages matériels.

Ne pas entreposer ni utiliser d'essence ni autres vapeurs ou liquides inflammables à proximité de cet appareil ou de tout autre appareil.

QUE FAIRE SI UNE ODEUR DE GAZ EST DÉTECTÉE

- Ne mettre en marche aucun appareil.
- Ne toucher aucun interrupteur électrique; ne pas utiliser de téléphone dans le bâtiment.
- Quitter le bâtiment immédiatement.
- Appeler immédiatement le fournisseur de gaz en utilisant le téléphone d'un voisin. Suivre les instructions du fournisseur de gaz.
- Si le fournisseur de gaz n'est pas accessible, appeler le service d'incendie.

L'installation et l'entretien doivent être effectués par un installateur ou une entreprise d'entretien qualifié, ou le fournisseur de gaz.

⚠ WARNING

CARBON-MONOXIDE POISONING HAZARD

Failure to follow instructions could result in severe personal injury or death due to carbon-monoxide poisoning, if combustion products infiltrate into the building.

Check that all openings in the outside wall around the vent (and air intake) pipe(s) are sealed to prevent infiltration of combustion products into the building.

Check that furnace vent (and air intake) terminal(s) are not obstructed in any way during all seasons.

⚠ AVERTISSEMENT

RISQUE D'INTOXICATION AU MONOXYDE DE CARBONE

Si ces directives ne sont pas suivies, cela peut entraîner des blessures graves ou une intoxication au monoxyde de carbone pouvant causer la mort, si des produits de combustion s'infiltrent dans le bâtiment.

Vérifier que toutes les ouvertures pratiquées dans le mur extérieur autour du ou des tuyaux d'évent (et de la prise d'air) sont scellées de manière à empêcher l'infiltration de produits de combustion dans le bâtiment.

Veiller à ce que la ou les sorties de l'évent de l'appareil de chauffage (et la prise d'air) ne soient, en aucune façon, obstruées, quelle que soit la saison.

⚠ WARNING

FIRE HAZARD

Failure to follow this warning could result in severe personal injury and/or property damage.

Inlet pressure tap set screw must be tightened and 1/8 in. NPT pipe plug must be installed to prevent gas leaks.

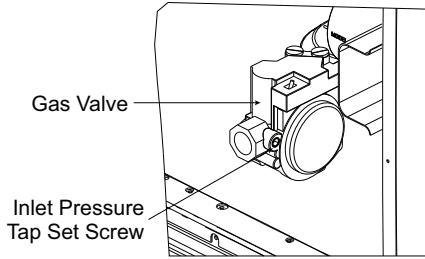

⚠ WARNING

FIRE HAZARD

Failure to follow this warning could result in severe personal injury and/or property damage.

Manifold pressure tap set screw must be tightened and 1/8 in. NPT pipe plug must be installed to prevent gas leaks.

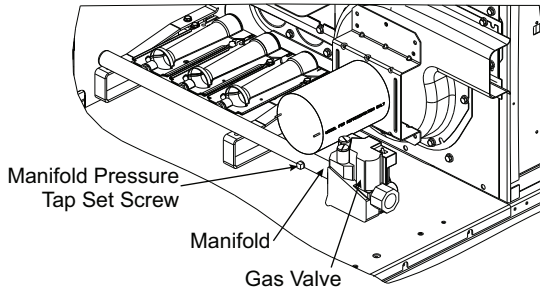

⚠ ADVERTISSEMENT

RISQUE D'INCENDIE

Le non-respect de cet avertissement pourrait entraîner des blessures graves et/ou des dommages matériels.

La vis de réglage du robinet de pression d'entrée doit être serrée et un bouchon de tuyau NPT de 1/8 po doit être installé pour éviter les fuites de gaz.

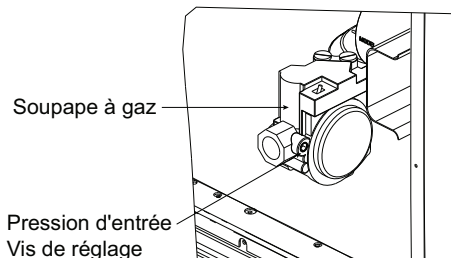

⚠ ADVERTISSEMENT

RISQUE D'INCENDIE

Le non-respect de cet avertissement pourrait entraîner des blessures graves et/ou des dommages matériels.

La vis de réglage du robinet de pression du collecteur doit être serrée et un bouchon de tuyau NPT de 1/8 po doit être installé pour éviter les fuites de gaz.

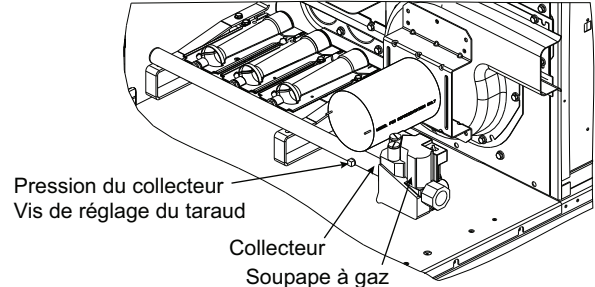

⚠ WARNING



This equipment may contain a UV-C LAMP. Look for this UVC warning on panels or doors before opening. Disconnect UVC power before opening access doors, removing panels, or installing, maintaining, or servicing UVC lamps or fixtures. Do not operate UVC with open access doors or with panels removed. Do not operate

UVC outside of unit cabinet. Exposure to UVC can cause harm to the eyes and skin. Review the UVC lamp accessory installation instructions for details on installing, testing, and maintaining UVC lamps.

⚠ ADVERTISSEMENT



Cet équipement peut contenir une LAMPE UV-C. Recherchez ces avertissements UVC sur les panneaux ou les portes avant de les ouvrir. Débranchez l'alimentation UVC avant d'ouvrir les portes d'accès, de retirer les panneaux ou d'installer, d'entretenir ou de réparer des lampes ou des luminaires UVC. N'utilisez pas de lampes UVC en dehors du boîtier de l'appareil. L'exposition aux UVC peut endommager les yeux et la peau. Consultez les instructions d'installation des accessoires de lampe UVC pour plus de détails sur l'installation, le test et l'entretien des lampes UVC.

L'exposition aux UVC peut endommager les yeux et la peau. Consultez les instructions d'installation des accessoires de lampe UVC pour plus de détails sur l'installation, le test et l'entretien des lampes UVC.

⚠ WARNING

ELECTRICAL SHOCK HAZARD

Failure to follow this warning could result in personal injury or death.

Before performing installation, service, or maintenance on this unit, turn off the main power disconnect to the unit and install lock and lockout tag. Ensure electrical service to DOAS unit agrees with voltage and amperage listed on the unit rating plate. Some equipment may have multiple power disconnects

⚠ ADVERTISSEMENT

RISQUE DE CHOC ÉLECTRIQUE

Le non-respect de cet avertissement pourrait entraîner des blessures corporelles, voire la mort.

Avant d'effectuer l'installation, l'entretien ou la maintenance de cet appareil, coupez l'alimentation principale de l'appareil et installez un verrou et une étiquette de verrouillage. Assurez-vous que le service électrique de l'unité DOAS correspond à la tension et à l'ampérage indiqués sur la plaque signalétique de l'appareil. Certains équipements peuvent avoir plusieurs disjoncteurs d'alimentation.

⚠ WARNING

This equipment is not intended for use by persons (including children) with reduced physical, sensory, or mental capabilities, or lack of experience and knowledge, unless they have been given supervision or instruction concerning use of the appliance by a person responsible for their safety. Children should be supervised to ensure that they do not play with the appliance.

⚠ ADVERTISSEMENT

Cet équipement n'est pas destiné à être utilisé par des personnes (y compris des enfants) ayant des capacités physiques, sensorielles ou mentales réduites, ou un manque d'expérience et de connaissances, à moins qu'elles n'aient reçu une supervision ou des instructions concernant l'utilisation de l'appareil par une personne responsable de leur sécurité. Les enfants doivent être surveillés pour s'assurer qu'ils ne jouent pas avec l'appareil.

⚠ CAUTION

PERSONAL INJURY HAZARD

Failure to follow this caution may result in personal injury. Sheet metal parts may have sharp edges or burrs. Use care and wear appropriate protective clothing, safety glasses and gloves when handling parts and servicing air conditioning equipment.

⚠ ADVERTISSEMENT

RISQUE DE BLESSURE CORPORELLE

Le non-respect de cette mise en garde peut entraîner des blessures corporelles.

Les pièces en tôle peuvent présenter des bords tranchants ou des bavures. Soyez prudent et portez des vêtements de protection appropriés, des lunettes de sécurité et des gants lors de la manipulation des pièces et de l'entretien des équipements de climatisation.

A2L REFRIGERATION INFORMATION

This equipment contains R-454B, a mildly flammable refrigerant classified as A2L. Read all instructions prior to transporting, storing, installing, or servicing this equipment.

R-454B		Refrigerant Safety Group A2L	R-454B
WARNING – Risk of Fire due to Flammable Refrigerant Used. Follow Handling Instructions Carefully in Compliance with National Regulations			

⚠ WARNING

Only use equipment and components that are designed for use with R-454B refrigerant.

⚠ ADVERTISSEMENT

Utilisez uniquement les équipements et les composants conçus pour être utilisés avec le réfrigérant R-454B.

Transportation

Follow all local, state, or federal regulations when transporting equipment containing A2L refrigerant. Carrier Packed DOAS units are designed to be transported on a flatbed trailer or flatbed rail car. Ensure the proper safety equipment, driver training, and any required trailer markings are in place prior to transporting equipment containing an A2L refrigerant. Units with an A2L refrigerant charge are not approved for air or cargo vessel transportation.

Minimum Conditioned Space Area

The space area served by ducted equipment with A2L refrigerant is restricted by building code based on refrigerant volume that the releasable to the conditioned space served by the duct system.

Determine the conditioned space area by calculating the floor area (room length x room width) of all spaces served by a common duct system and adding them all together to get the total conditioned space area.

Compare the calculated total conditioned space area to the minimum conditioned space area (TA_{min}) listed in Tables 1 and 2, based on the unit size.

If the space area is above the minimum conditioned space area listed in Tables 1 and 2 (based on unit size and configuration), no action is needed.

If the conditioned space area is below the minimum conditioned space area listed in Tables 1 and 2 (based on unit size and configuration), then additional ventilation may be required. Refer to local code, UL-60335-2-40, or ASHRAE standard 15.

⚠ CAUTION

Do not install an ignition source or potential ignition source in a space where the total conditioned area is below the minimum total conditioned area (TA_{min}), unless a flame arresting device has been installed.

⚠ ADVERTISSEMENT

N'installez pas de source d'inflammation ou de source potentielle d'inflammation dans un espace où la surface totale conditionnée est inférieure à la surface totale conditionnée minimale (TA_{min}), à moins qu'un dispositif pare-flammes n'ait été installé.

Table 1 – 62H Cooling Only

CAPACITY (TONS)	R-454B REFRIGERANT CHARGE (MC)		Q _{min} MINIMUM CIRCULATION AIRFLOW CIRCULATED TO THE TOTAL CONDITIONED SPACE (GG.15DV)		TA _{min} (m ²) MINIMUM AREA OF THE TOTAL CONDITIONED SPACE IN m ² (GG.17DV)	
	lb	kg	m ³ h	CFM	m ²	ft ²
3	24	10.8	1069	630	32	349
4	24	10.8	1069	630	32	349
5	24	10.8	1069	630	32	349
6	30	13.5	1337	787	41	436
7	30	13.5	1337	787	41	436
8	30	13.5	1337	787	41	436
10	34	15.3	1515	892	46	494
12.5	34	15.3	1515	892	46	494
15	34	15.3	1515	892	46	494
18	34	15.3	1515	892	46	494
20	34	15.3	1515	892	46	494
25	55	24.8	2450	1443	74	799
30	55	24.8	2450	1443	74	799
35	55	24.8	2450	1443	74	799
40	78	35.1	3475	2047	105	1134
45	85	38.3	3787	2231	115	1235
50	85	38.3	3787	2231	115	1235
55	114	51.3	5079	2992	154	1657

Table 2 – 62H Heat Pump

CAPACITY (TONS)	R-454B REFRIGERANT CHARGE (MC)		Q _{min} MINIMUM CIRCULATION AIRFLOW CIRCULATED TO THE TOTAL CONDITIONED SPACE (GG.15DV)		TA _{min} (m ²) MINIMUM AREA OF THE TOTAL CONDITIONED SPACE IN m ² (GG.17DV)	
	lb	kg	m ³ h	CFM	m ²	ft ²
3	31	14.0	1381	814	42	451
4	31	14.0	1381	814	42	451
5	31	14.0	1381	814	42	451
6	41	18.5	1827	1076	55	596
7	41	18.5	1827	1076	55	596
8	41	18.5	1827	1076	55	596
10	42	18.9	1871	1102	57	610
12.5	42	18.9	1871	1102	57	610
15	42	18.9	1871	1102	57	610
18	42	18.9	1871	1102	57	610
20	84	37.8	3743	2204	113	1221
25	84	37.8	3743	2204	113	1221
30	84	37.8	3743	2204	113	1221
35	84	37.8	3743	2204	113	1221
40	120	54.0	5347	3149	162	1744
45	120	54.0	5347	3149	162	1744
50	120	54.0	5347	3149	162	1744
55	144	64.8	6416	3779	194	2093

GENERAL

This Installation Instructions literature is for Carrier 62H Series packaged dedicated outdoor air units. 62H Series units are designed for outdoor installation only, do not install indoors. For additional information on installation, operation, and service, refer to the Advanced Controls, Operation, and Troubleshooting guide, Service Manual, Integration guide, or accessory installation instructions.

PRE-INSTALLATION

Inspection

Upon receipt of shipment, carefully check the shipment against the bill of lading. Make sure all units have been received. Inspect each unit for damage on both the interior and exterior. Ensure the shipping company makes proper notation of any shortages or damage on all copies of the freight bill.

Concealed damage not discovered during unloading must be reported to the shipping company within 5 days of receipt of shipment.

NOTE: It is the responsibility of the purchaser to file all necessary claims with the shipping company.

Unit Storage

Carrier 62H Series units are designed for outdoor installation. However, due to scheduling or building closures, it may need to be stored either on the ground or in its final position. During storage, internal components, whether powered in standby mode or unpowered, may be exposed to conditions unsuitable for subsequent operation. Proper steps must be taken to ensure they remain operational without damage.

Storage Guidelines

DRY LOCATION

Store the equipment in a dry location. Ensure adequate blocking under the base rail to provide proper support. Inadequate support may result in damage when removing screws and opening doors. Ensure the unit is well supported along the entire length of the base rail.

DRAINAGE

Provide proper drainage around the equipment to prevent flooding.

CONDENSATION PREVENTION

Take steps to prevent condensation inside the unit's electrical components and motors. Isolate all side panel service openings, such as conduits, flue, supply air, and return air holes, to minimize the introduction of ambient air until the unit is installed on the curb and prepared for start-up.

PROTECTION

Provide adequate protection from vandalism, mechanical contact, and other potential damages. Condenser fins are particularly vulnerable and can be damaged even by light contact.

Temporary Operation for a Completed Building

Carrier does not recommend operating the supply fan, cooling, dehumidification, or heating systems of this equipment prior to equipment start-up being performed. Operating the equipment prior to start-up can cause damage to the equipment. Damaged caused by improper operation is not covered under Carrier's standard or extended warranties.

If temporary operation of equipment is required, Carrier recommends performing a start-up on the equipment system that requires temporary operation, such as heating or cooling. Performing a start-up on the system will help ensure proper operation.

Temporary Operation for an Under-Construction

This product is not designed to operate in a construction environment. Extensive equipment damage can be caused by operating this equipment while construction, renovation, or remodeling is occurring in the space or near the equipment. Carrier recommends using equipment designed for specific construction duty or specialized application duty based on the construction or application need.

INSTALLATION

Step 1 — Check Jobsite

Installation, operation and maintenance instructions are provided with each unit. Before unit start-up, read all manuals and become familiar with the unit and its operation. Thoroughly check out the system before operation. Complete the inspections and instructions listed below to prepare a unit for installation. See Tables 3-7 for required clearances and unit example physical data. See the unit submittal for actual unit dimensions. See Fig. 1 for label placement.

WARNING

Electrical shock can cause personal injury and death. Shut off all power to this equipment during installation and service. There may be more than one disconnect switch. Tag all disconnect locations to alert others not to restore power until work is completed.

IMPORTANT: The installation of dedicated outdoor air units and all associated components, parts, and accessories which make up the installation shall be in accordance with the regulations of ALL authorities having jurisdiction and MUST conform to all applicable codes. It is the responsibility of the installing contractor to determine and comply with ALL applicable codes and regulations.

INSTALLATION GUIDELINES (ALL UNITS)

1. Be sure that the location chosen for unit installation provides adequate space for condenser airflow.
2. Verify that the outdoor air intake is away from any from any exhaust or other contaminant sources and is in accordance with local codes.
3. For units with gas heat, ensure proper clearance for flue gas exhaust. Ensure flue gas exhaust is away from the outdoor air intake of other equipment. For proper unit operation, adequate combustion and ventilation air must be provided in accordance with Section 5.3 (Air for Combustion and Ventilation) of the National Fuel Gas Code, ANSI Z223.1 (American National Standards Institute). Verify proper access to make gas pipe connections.
4. For units with a power exhaust, verify that the exhaust outlet is free from obstruction.
5. For units with hot water heat, verify access for hot water pipe routing and valve installation.
6. Verify that the unit is installed with proper access and clearance in accordance with recommended service clearances, which is 48 in. on all sides of the unit. See page 16 and page 17 for unit dimensions.
7. Be sure that the unit can be installed with the proper pitch to encourage condensate drainage.
8. Verify the installation location is isolated from sleeping areas, private offices and other acoustically sensitive spaces.

9. For units with horizontal duct connection, provide sufficient space for duct connections and transitions.
10. Provide sufficient access to make power and control wiring connections.

11. Verify the unit power connection and control panel are away from any conductive services in accordance with local code.

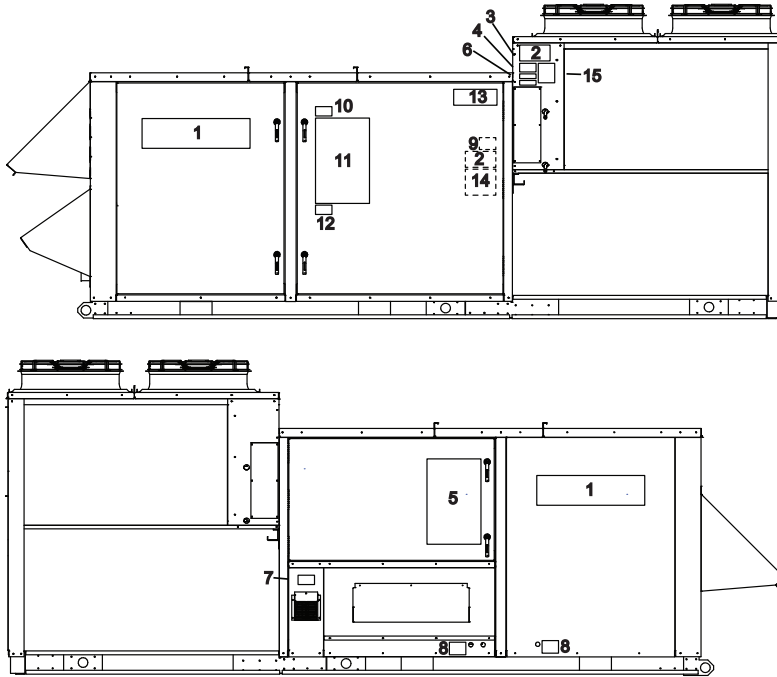

Description:	Location:
Brand Logo	1
Serial Data Plate	2
CA Prop 65 Label	3
R-454B Label	4
Fan Warning Label	5
Quality Inspection Stamp	6
Hot Surface Label	7
Condensate Trap Label	8
Copper Conductors Label	9
Additional Parts Label	10
Electrical Warning Label	11
Door Latch & Lock Label	12
R-454B Data Label	13
R-454B Warning Label	14
R-454B Warning Label	15

Fig. 1 — Label Placement

Step 2 — Check Unit

Upon receipt of equipment at the jobsite, inspect each unit for damage on both the interior and exterior. Note any damage and contact your local equipment sales office.

INSPECT UNIT

To prepare the unit for installation, complete the procedures listed on Steps 1-9:

1. Verify that the correct unit has been received. Check the unit capacity (tonnage), voltage, orientation, and configuration.
2. Compare the electrical data on the unit nameplate with the submittal report to verify the jobsite power feed (voltage, amperage, MCA) and power protection (MOCP).
3. Verify that the unit is the correct model number.
4. Verify all required field installed components, including sensors, control interface, etc. have been received.
5. Check the refrigerant piping connections to make sure they are free from defects, kinks, dents, and leaks.
6. Inspect the blower assembly. Verify that the blower has not come loose during shipping. Verify free blower rotation.
7. For units with energy conservation wheel (ECW), verify the ECW assembly and the drive assembly (belt and motor).
8. Inspect all electrical connections. Be sure connections are clean and tight at the terminals.
9. Verify that the control interface Equipment Touch (standard feature) is installed. Alternate control interfaces may be available. See Controls, Operations and Start-up Manual. Consult Unitary Applications.

Step 3 — Provide Unit Support

ROOF CURB

Assemble or install accessory roof curb in accordance with instructions shipped with this accessory. See submittal drawings for roof curb dimensions. Install insulation, cant strips, roofing, and counter flashing, if required. For vertical supply and return connections, ductwork can be installed to roof curb before unit is set in place. Ductwork must be attached to curb and not to the unit. Curb must be level. This is necessary to permit unit drain to function properly. Unit leveling tolerance is $\pm 1/16$ in. per linear ft in any direction. Refer to Accessory Roof Curb Installation Instructions for additional information as required. When accessory roof curb is used, unit may be installed on class A, B, or C roof covering material. Carrier roof curb accessories are for flat roofs or slab mounting. See “Roof Curb Installation” on page 11 for typical arrangements.

IMPORTANT: The gasketing of the unit to the roof curb is critical for a watertight seal. Install gasket with the roof curb. Improperly applied gasket can also result in air leaks and poor unit performance. Do not slide unit to position on roof curb.

Step 4 — Rig and Place Unit

See Tables 4-7 for physical data. See Fig. 2-6 for illustrations on lifting small and large units. File any claim with transportation agency.

⚠ CAUTION

UNIT DAMAGE HAZARD

Failure to follow this caution may result in equipment damage. All panels must be in place when rigging. Unit is not designed for handling by fork truck when packaging is removed. If using top crate as spreader bar, once unit is set, carefully lower wooden crate off building roof top to ground. Ensure that no people or obstructions are below prior to lowering the crate.

Do not drop unit; keep upright. Use wooden top skid or spreader bars over unit to prevent sling or cable damage. Rollers may be used to move unit across a roof. Level by using unit rail as a reference; leveling tolerance is $\pm 1/16$ in. per linear ft in any direction. Refer to the DOAS (Dedicated Outdoor Air System) Builder generated submittal for weights and dimensions of a unit.

LIFTING A PACKAGED DOAS

The unit must be installed in compliance with all applicable codes. The qualified installer or service technician must use best building practices when installing the unit.

MOVING/LIFTING A PACKAGED AIR CONDITIONING UNIT

Preparing to Move/Lift the Unit:

Prior to moving/lifting the unit, the following steps must be performed.

1. Remove all packaging or blockers.
2. Remove all packages that were shipped inside the unit.
3. Inspect the unit to:
 - a. Verify that there is no damage as a result of shipping.
 - b. Ensure that it is appropriately rated for the utilities available at the installation site.
 - c. Verify that the lifting lugs are intact, undamaged and secured to the packaged air conditioning unit.
 - d. Ensure factory-installed hardware is torqued as specified.
4. Prepare the installation location to be ready to accept the unit (i.e., roof curb is correct size).
5. Verify that the moving/lifting equipment can handle the unit's weight. Verify that forklift forks extend through the unit frame and that crane has required reach.

Moving the Unit with a Forklift

On smaller A, B, and some C cabinet units, forklift pockets are provided for lifting and moving. The following must be considered before using this option.

- Forklift must be rated for the weight of the unit.
- Forklift must have forks long enough to go through both side pockets and not rest on the underside basepans of the unit.
- Care must be taken to not jar the unit, bounce, or drop the unit during move.

⚠ WARNING

CRUSH HAZARD

Use proper lifting equipment and practices. Failure to follow these instructions can result in death, injury, or property damage.

Lifting the Unit with Crane

Lift the unit into place installing appropriate hardware (supplied by others) into all four lifting lugs holes on small units, and up to 8 on larger cabinets. Use spreader bars to ensure that the lifting cables clear the sides of the unit. See Fig. 4-6 for lifting unit examples. Test lift to 12 in. [30.5 cm] to check stability of rigging before completing the lift. Use caution as the load may be unbalanced. The unit must be kept level during the lift to prevent tipping, twisting or falling. If lifted improperly, product damage may occur.

POSITIONING

Maintain clearance around and above unit to provide minimum distance from combustible materials, proper airflow, and service access.

Do not install unit in an indoor location. Do not locate air inlets near exhaust vents or other sources of contaminated air. For proper unit operation, adequate combustion and ventilation air must be provided in accordance with Section 5.3 (Air for Combustion and Ventilation) of the National Fuel Gas Code, ANSI Z223.1 (American National Standards Institute).

Although unit is weatherproof, guard against water from higher level runoff and overhangs. Select a location where external water drainage cannot collect around the unit. Where snowfall is anticipated, mount the unit so all intakes and discharges are above the maximum snow depth for the area.

Unit shall not be installed with inlet opening facing into the prevailing wind direction in order to help prevent the possibility of moisture entrainment.

For gas heat units, locate mechanical draft system flue assembly at least 4 ft from any opening through which combustion products could enter the building, and at least 4 ft from any adjacent building (or per local codes). When the unit is located adjacent to public walkways, flue assembly must be at least 7 ft above grade. Locate unit at least 10 ft away from adjacent units.

Clearances

The clearances listed in the Service, Ventilation, and Required Clearance sections are the required distances that the unit must be away from objects and other units to allow service access and proper operation of the unit. See Fig. 7 and 8 for unit dimensions.

Service Clearances

The minimum recommended service clearance is 48 in. on all sides of unit with access doors.

Ventilation Clearances

In order to ensure proper operation of an air source unit, a 24 in. clearance for ventilation must be maintained on the sides. In addition, specific ventilation situational clearance guidelines are listed below.

- Do not locate the unit under an overhang or near a wall or other equipment that fosters short circuiting hot air to the condenser coil intakes.
- Do not locate unit within 10 ft, or directly downwind, from exhaust fans or flues.
- Do not locate adjacent unit condenser sections closer than 6 ft to one another to reduce the possibility of condenser air circulation. Follow the minimum required clearances listed in Service, Ventilation, and Required Clearance sections or in Fig. 2 and Table 3 (whichever is greater).

Required Clearances

Clearances are the required distances that the unit must be away from objects and other units to allow service access and proper operation of the unit.

Table 3 — Required Clearances^a

Cabinet	A (in.)	B (in.)	C (in.)	D (in.)
B	56	48	41	48
C	62	48	44	48
D	80	48	56	48

NOTE(S):

- a. Minimum clearance required for the side removal of energy recovery wheels and/or DX coils.

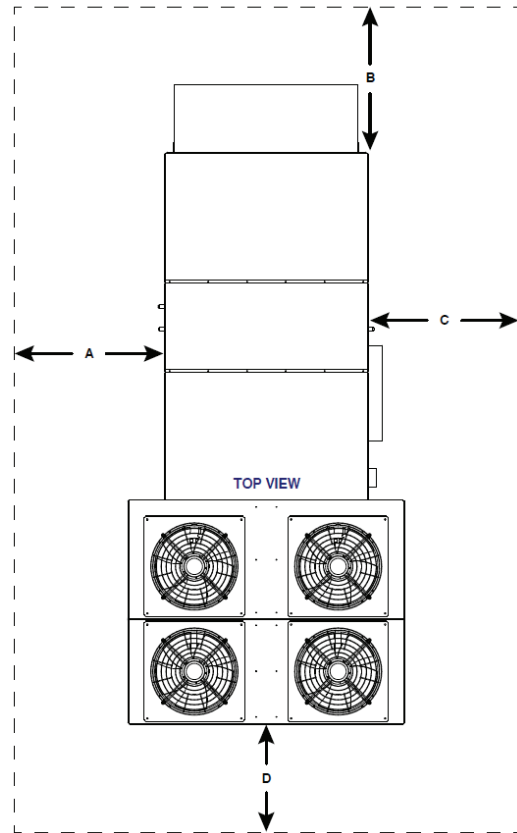

Fig. 2 — Required Clearances

ROOF MOUNT

Check building codes for weight distribution requirements. Unit operating weight is shown in the DOAS Builder generated submittal. When installing the equipment on top of a building, the following should be considered. Structural members supporting the unit must be sufficiently strong for the weight of the unit and mounting rails. Transmission of sound into the building is sometimes a problem when the structure is not strong enough.

SLAB MOUNT

When installed at ground level, the unit should be mounted on a level concrete slab which should extend at least 2 in. beyond the unit on all sides. The top of the slab should be 2 in. above the ground level. The depth of the slab below the ground level and its structural design is governed by the type of soil and climatic conditions. The slab must not be in contact with any part of the building wall or foundation. The space between the slab and building wall prevents the possibility of transmitting vibration to the building. The dimensions of the slab or roof mount should be checked and verified before the equipment arrives. Consider the condensate water trap height when mounting the unit on a slab. The unit is typically mounted on a curb with ductwork and utility connections usually going through the curb. It may also be pad-mounted. (Contact factory for specific instructions if unit is to be mounted in a different way [i.e., on mounting stand].)

INSTALLATION ONTO CURB

Correct placement of the unit onto the curb is important to operating performance. Refer to product submittal drawings to assure proper duct opening alignment. For locations with seismic or wind load requirements, field engineered and provided curb attachment clips must be provided. The standard Carrier curb is not wind or seismic rated.

NOTE: Refer to unit certified drawing for details on the actual cross section shape of the base rail, the above drawing is showing a reference only of the base rail. The actual shape of the base rail may differ from what is shown in Fig. 3.

⚠ CAUTION

Do not slide unit into position when it is sitting on the curb. Curb gasketing material may be damaged and leaks may result.

NOTE: For weight references, consult the DOAS Builder program submittal.

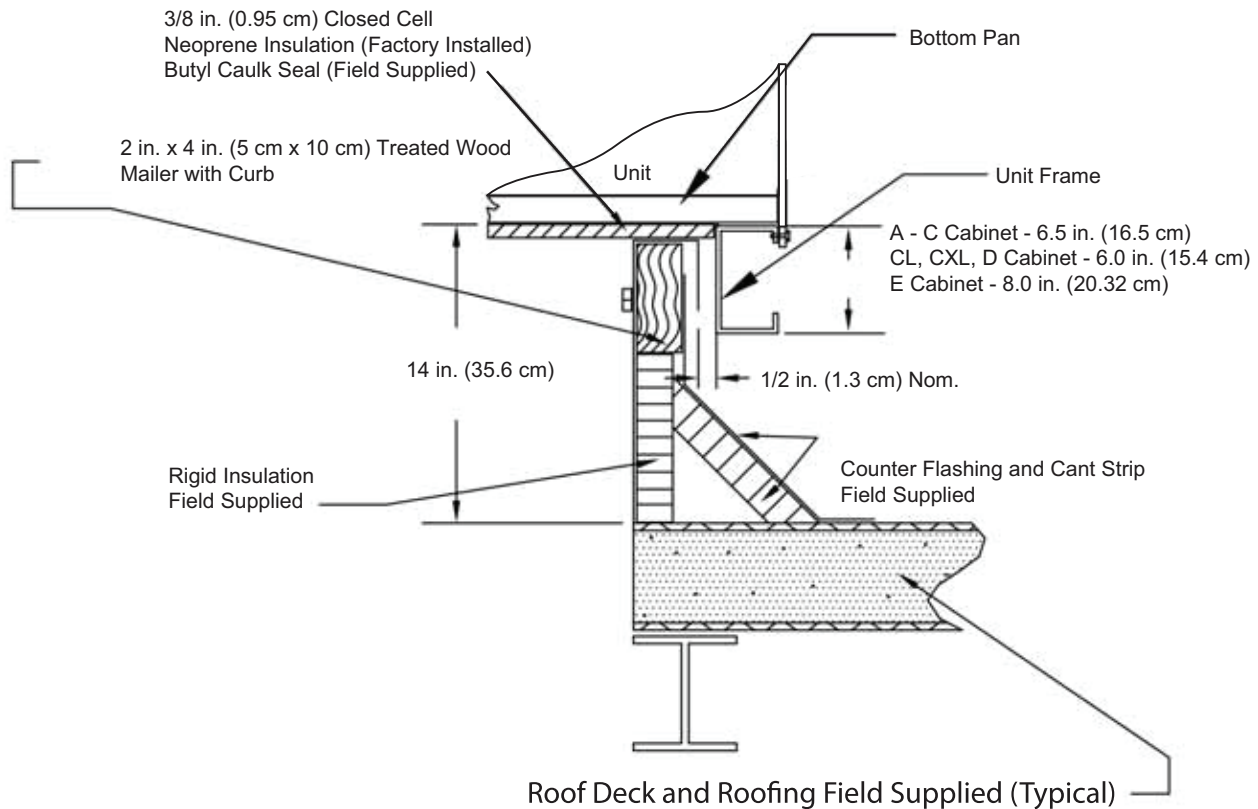

Fig. 3 – Roof Curb Installation

Adjust cable length to lift points as necessary based on unit center of gravity.

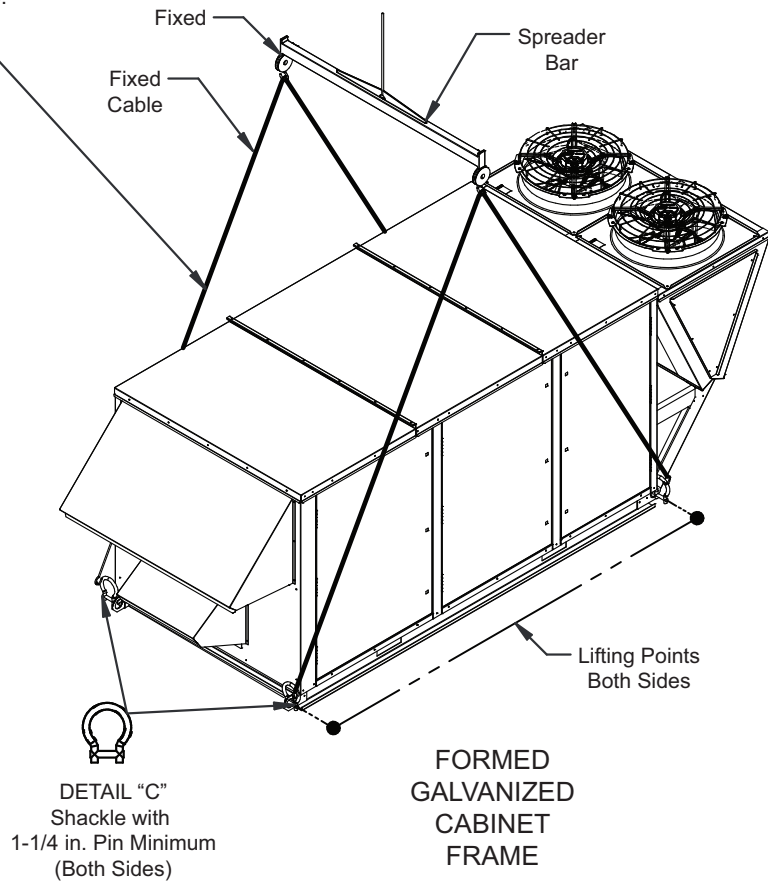
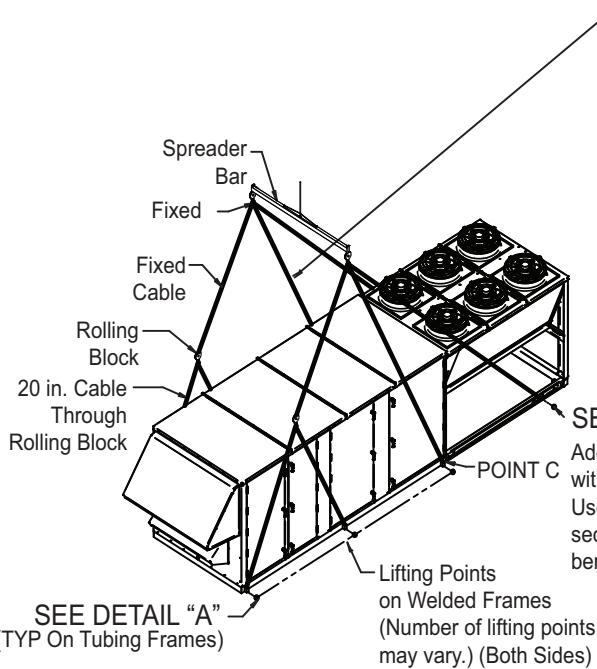
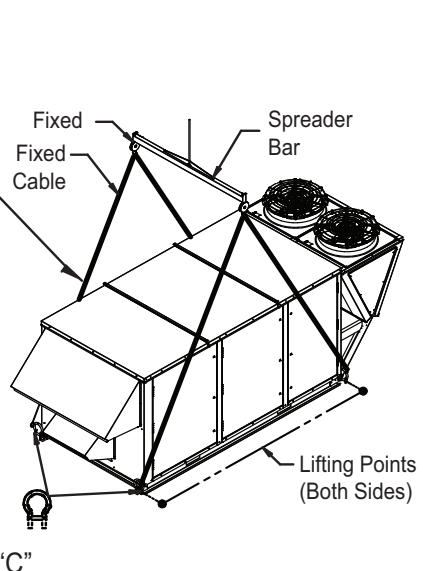
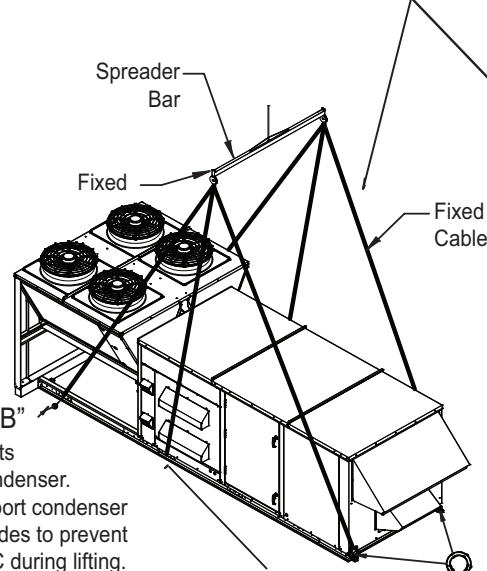

Fig. 4 — Lifting a Small Unit (B Cabinets)

Adjust Cable Length to Lift Points as Necessary Based on Unit Center of Gravity



SEE DETAIL "B"
Additional lift points with extended condenser. Used only to support condenser section on both sides to prevent bending at point C during lifting.



DETAIL "C"
Shackle with 1-1/4 in. Pin Minimum (Both Sides)

13

WELDED TUBING CABINET FRAME

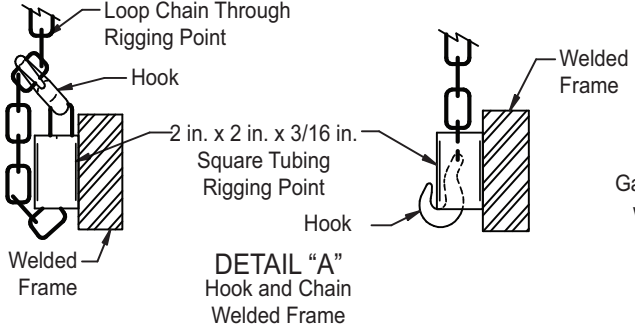

FORMED GALVANIZED CABINET FRAME

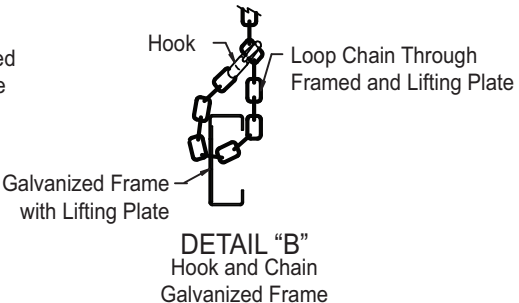

FORMED GALVANIZED CABINET FRAME

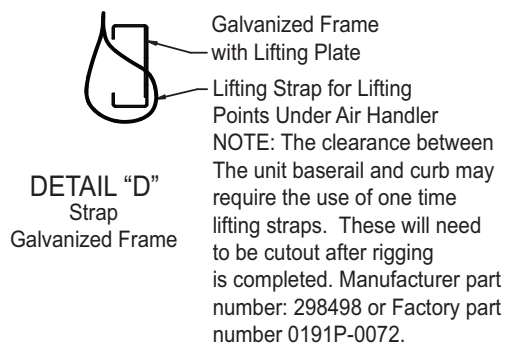
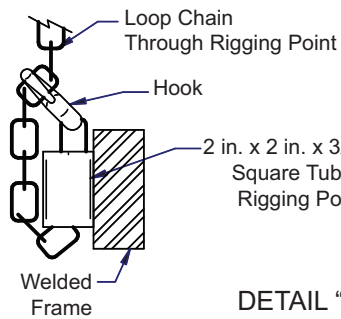
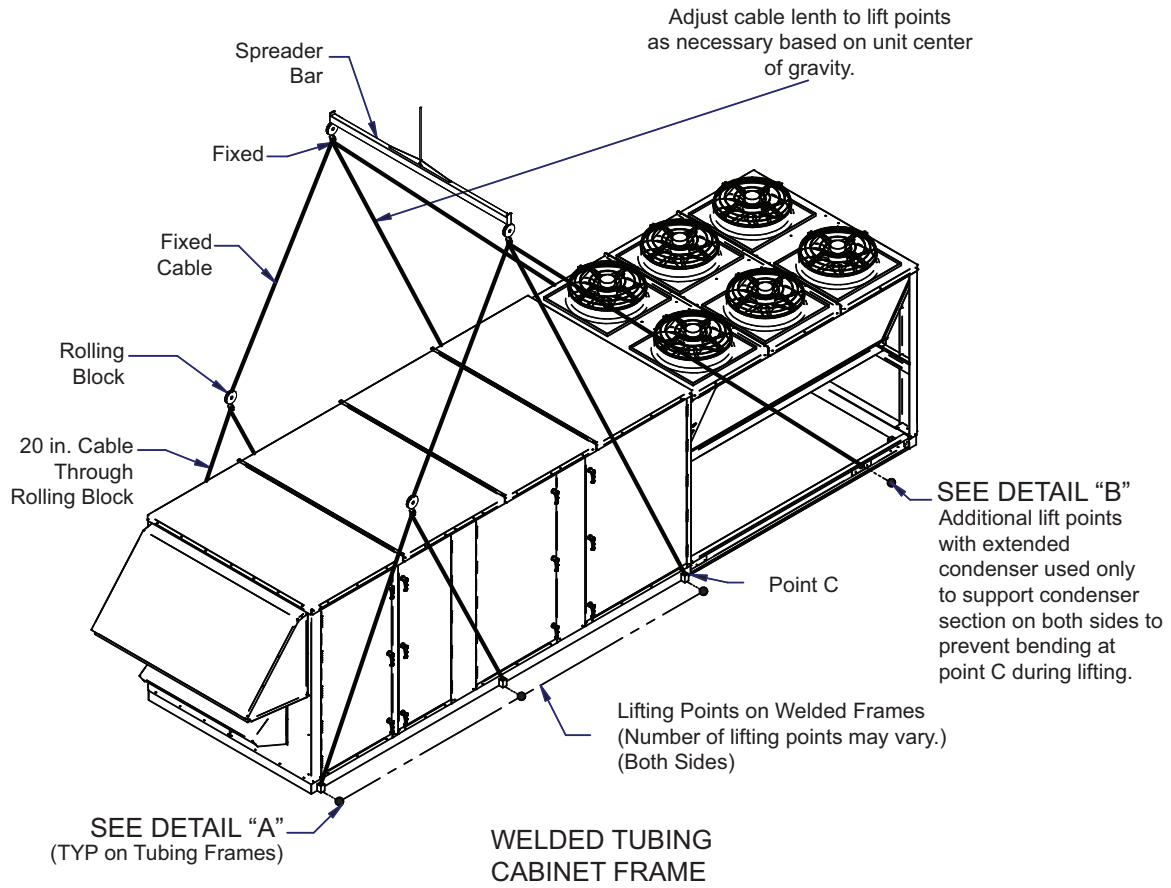
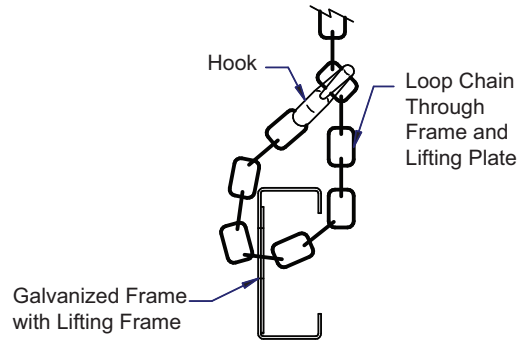
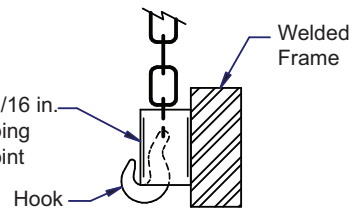

Fig. 5 — Lifting a Medium Unit (C,CL, CXL)



DETAIL "A"
Hook and Chain
Welded Frame



DETAIL "B"
Hook and Chain
Galvanized Frame

Fig. 6 — Lifting a Large Unit (D Cabinet)

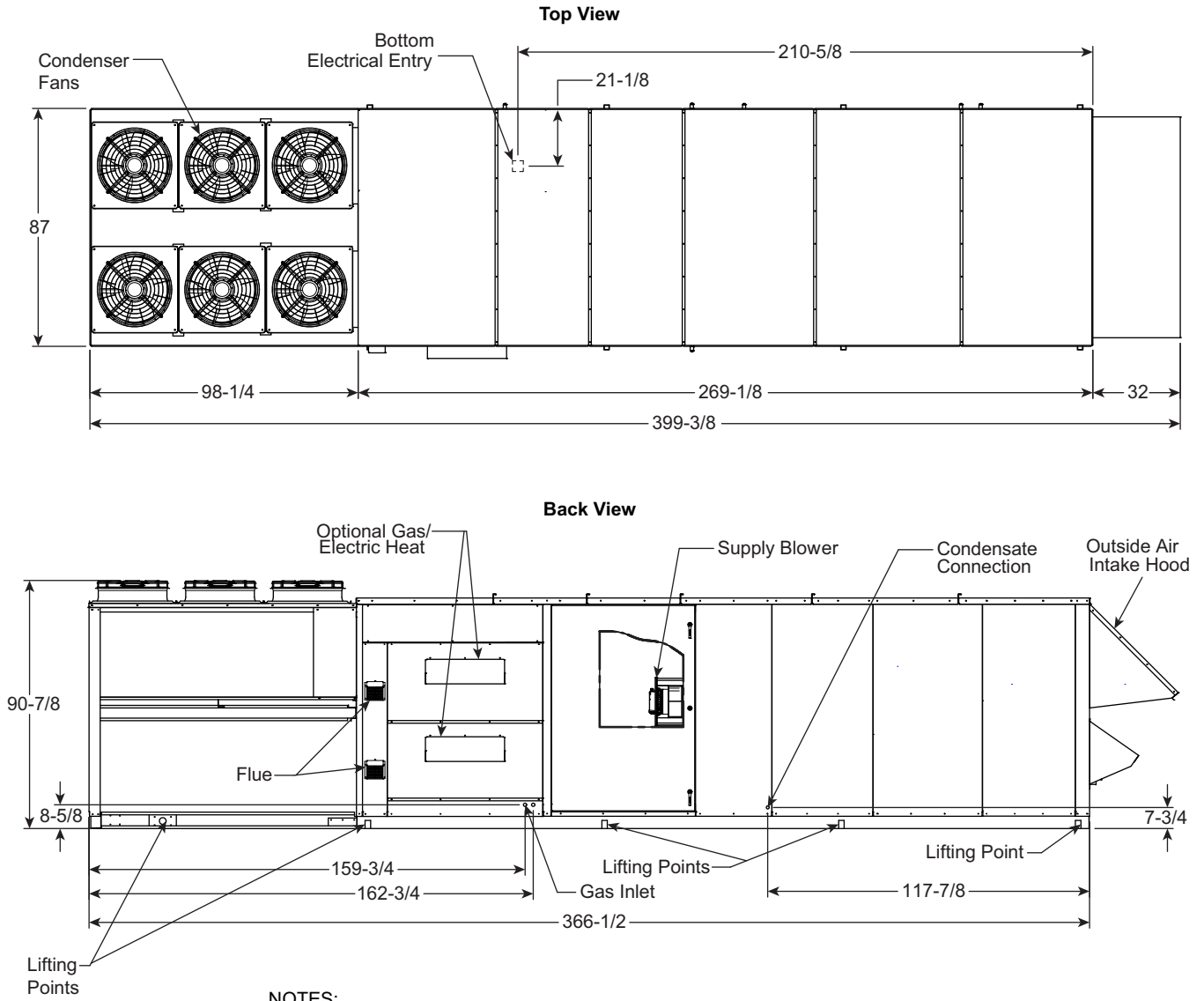

NOTES:

1. Dimensions are in inches.
2. For detailed information on unit dimensions, please refer to a latest edition of Carrier's Dedicated Outdoor Air Systems Builder.
3. For an exact unit drawing, please refer to the DOAS Builder generated submittal.

Fig. 7 – Unit Dimensions – 62H DXL Cabinet, High Efficiency (Sizes 25-35), ERV, Vertical Supply, Vertical Exhaust

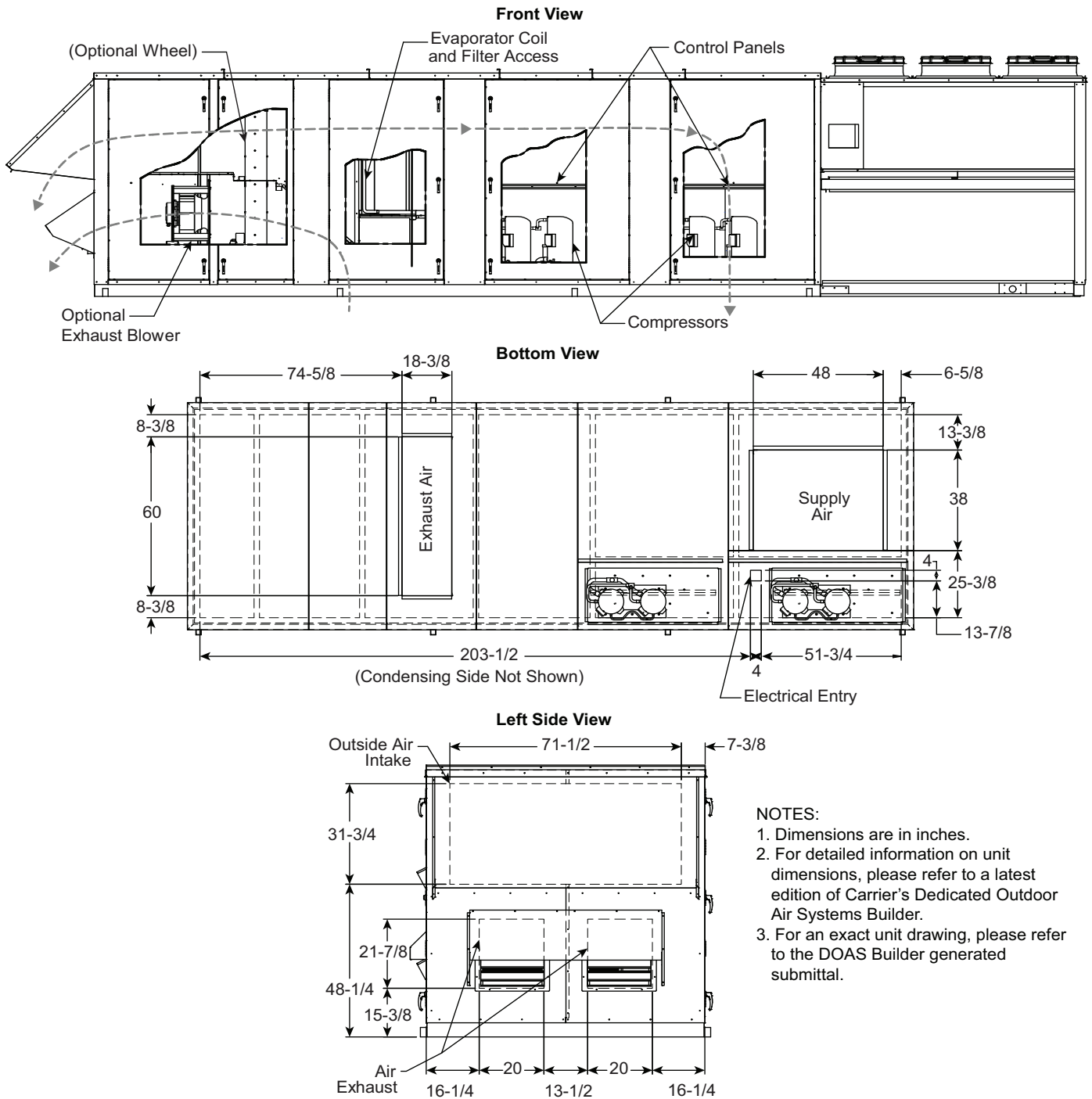

Fig. 7 – Unit Dimensions – 62H DXL Cabinet, High Efficiency (Sizes 25-35), ERV, Vertical Supply, Vertical Exhaust (cont)

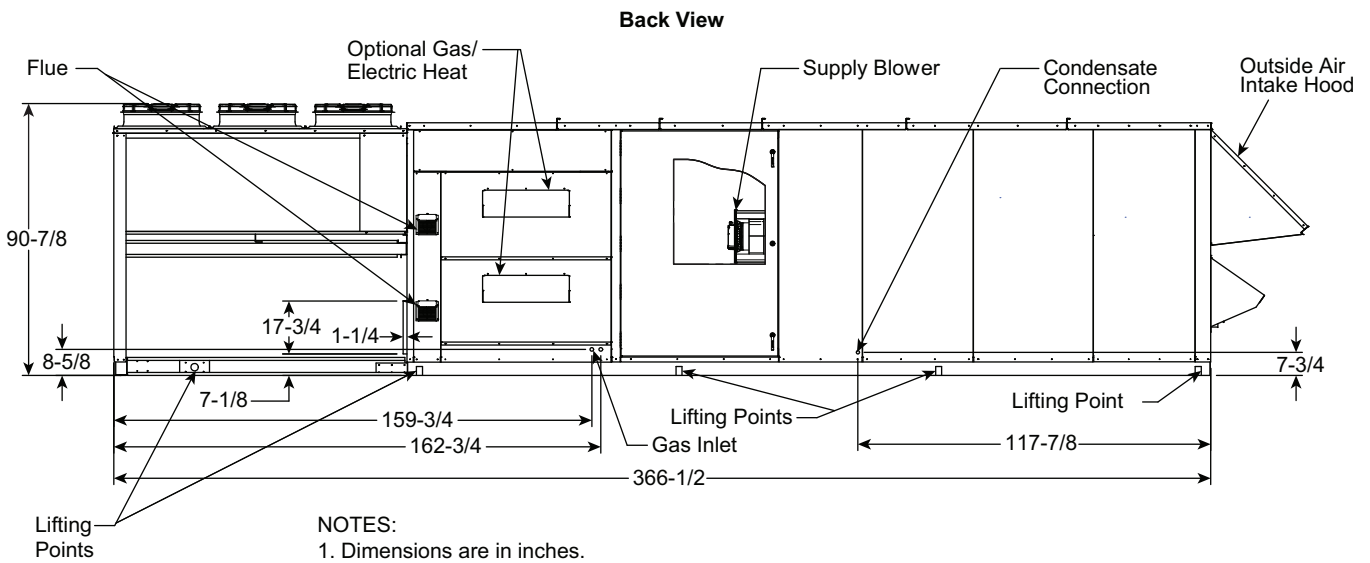
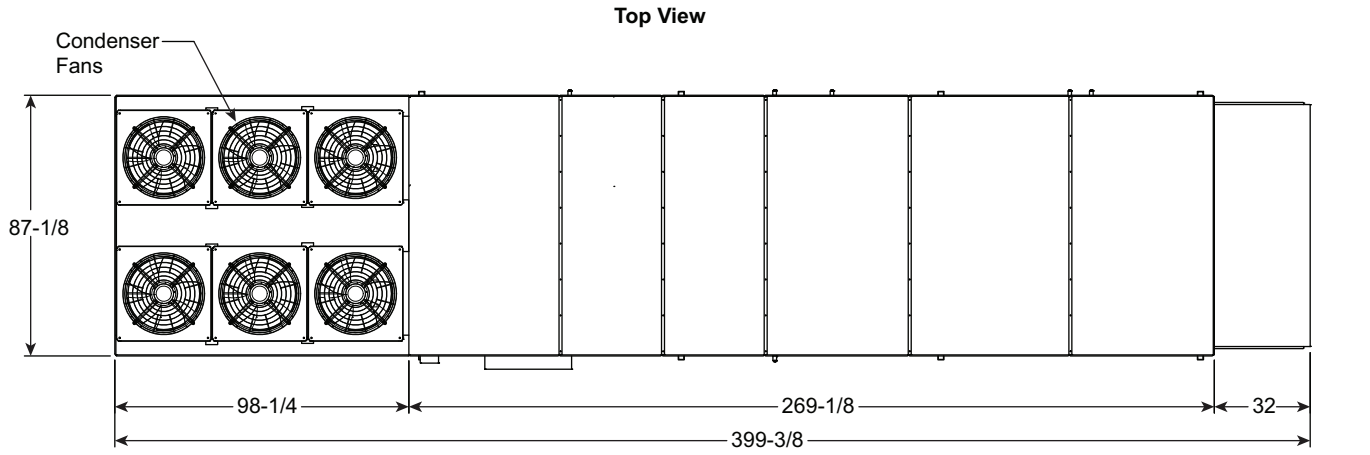
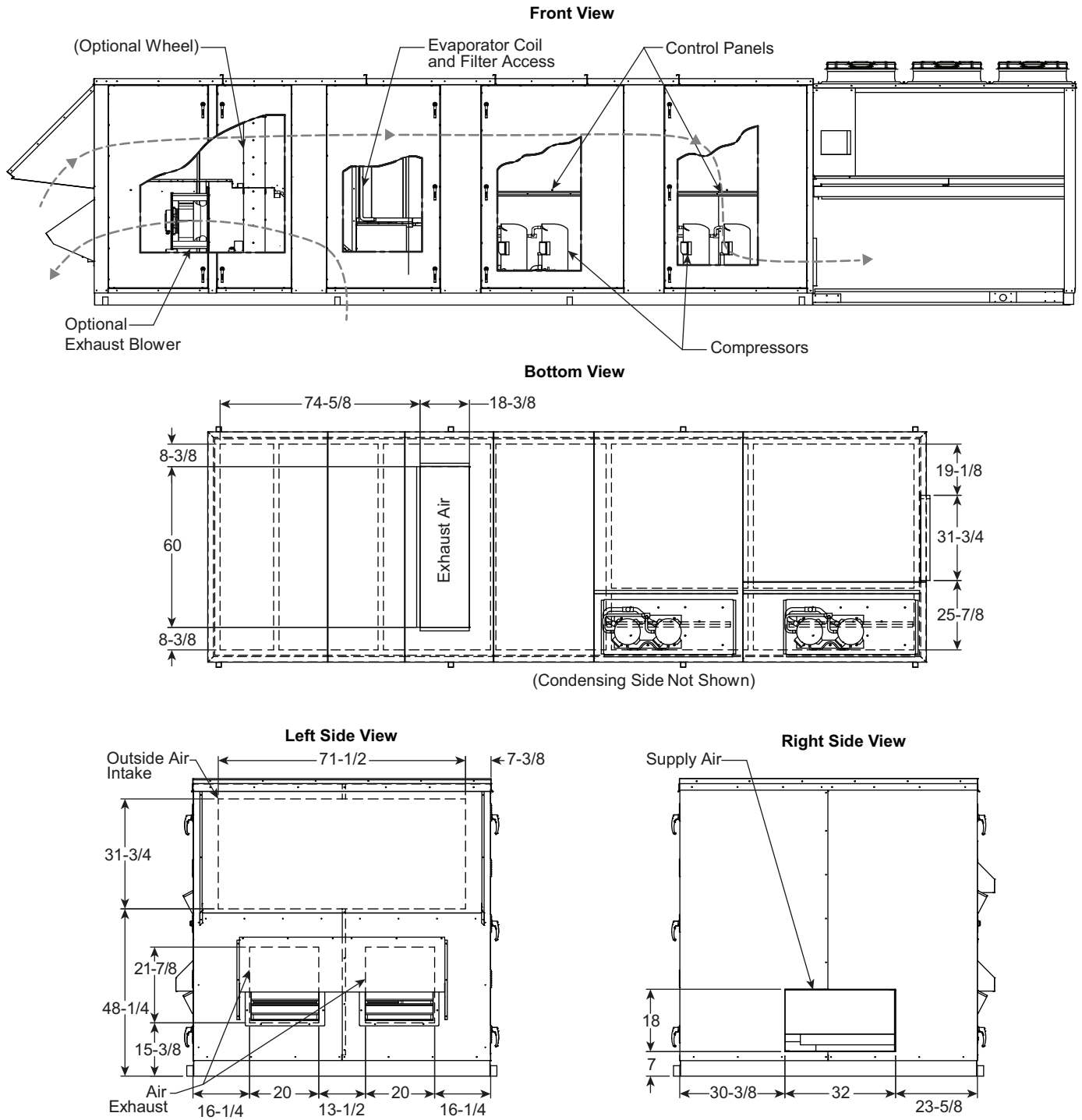

Fig. 8 — Unit Dimensions — 62H DXL Cabinet, High Efficiency (Sizes 25-35), ERV, Horizontal Supply, Vertical Exhaust



- NOTES:
1. Dimensions are in inches.
 2. For detailed information on unit dimensions, please refer to a latest edition of Carrier's Dedicated Outdoor Air Systems Builder.
 3. For an exact unit drawing, please refer to the DOAS Builder generated submittal.

Fig. 8 — Unit Dimensions — 62H DXL Cabinet, High Efficiency (Sizes 25-35), ERV, Horizontal Supply, Vertical Exhaust (cont)

Table 4 – Physical Data – 62H B Cabinet^{a,b,c}

UNIT 62H B CABINET	03	04	05	06	07	08
NOMINAL CAPACITY (TONS)	3	4	5	6	7	8
No. of Refrigerant Circuits	1					
Oil	Pre-Charged					
REFRIGERANT TYPE	R-454B					
OUTDOOR COIL						
Standard Efficiency Condenser (sq ft)	10			13.5		
High-Efficiency Condenser (sq ft)	—			27		
OUTDOOR FAN						
Standard Efficiency Condenser without ERV						
Quantity...Diameter (mm)	1...630					
Motor Hp	1.48					
High Efficiency Condenser without ERV						
Quantity...Diameter (mm)	—			2...630		
Motor Hp	—			1.48		
Standard Efficiency Condenser with ERV						
Quantity...Diameter (mm)	1...630					
Motor Hp	1.48					
High Efficiency Condenser with ERV						
Quantity...Diameter (mm)	—			2...630		
Motor Hp	—			1.48		
INDOOR COIL						
Face Area without ERV (sq ft)	2.8			4.7		
Face Area with ERV (sq ft)	7			10		
SUPPLY FAN						
Backward Curved ECM (mm)	350, 450 (High)					
Airfoil (in.)	12, 14, 16					
Backward Inclined (in.)	10, 11, 12, 14, 16					
Nominal cfm 100% OA	450	600	750	900	1050	1200
Motor Hp Range	ECM, 1, 1.5, 2, 3, 5					
OPTIONAL HOT GAS REHEAT AND LIQUID SUBCOOLING COIL						
Face Area without ERV (sq ft)	2.8			4.7		
Face Area with ERV (sq ft)	7			10		
CONDENSATE DRAIN CONNECTION (NPT) (in.)	0.75					
OPTIONAL GAS HEAT SECTION						
Gas Input Sizes (Btuh x 1000)	75, 100, 150, 200					
Control Type						
Stages (no. of stages)	2					
Modulating (% range) ^b	5:1, 10:1 ^b					
Efficiency (Steady State) (%)	81					
Supply Line Pressure Range (in. wg)	5.0 min. - 13.5 max					
Rollout Switch Cutout Temp (°F)	350					
Gas Valve Quantity	1 Std - 2 with modulating option					
Manifold Pressure (in. wg)						
Natural Gas Std	3.5					
LP Gas Special Order	10					
OPTIONAL ELECTRIC HEAT						
Size Range (kW)	5, 10, 15, 20, 25, 30, 35, 40, 50, 60, 70, 80, 100					
Control Type						
Stages (no. of stages)	1, 2, 4					
SCR (% range) ^d	0-100					
OPTIONAL HOT WATER HEAT COIL WITH ERV	27.5 x 27.5, 4 row, 8 FPI. See Hot Water Coil Drawings.					
OPTIONAL HOT WATER HEAT COIL WITHOUT ERV	27.5 x 27.5, 4 row, 8 FPI. See Hot Water Coil Drawings.					
OUTDOOR AIR FILTERS						
Quantity...Size (in.) with ERV						
Standard 2 in. MERV 8	2...24x24			4...16 x 25		
Optional 4 in.						
MERV 8	2...24x24			4...16 x 25		
MERV 11	2...24x24			4...16 x 25		
MERV 13	2...24x24			4...16 x 25		

Table 4 – Physical Data – 62H B Cabinet^{a,b,c} (cont)

UNIT 62H B CABINET	03	04	05	06	07	08
NOMINAL CAPACITY (TONS)	3	4	5	6	7	8
Quantity...Size (in.) without ERV						
Standard 2 in. MERV 8	1...24x24			2...24x24		
Optional 4 in.						
MERV 8	1...24x24			2...24x24		
MERV 11	1...24x24			2...24x24		
MERV 13	1...24x24			2...24x24		
OPTIONAL ERV						
Type	Synthetic Polymer					
Diameter (in.)...depth (mm)	30...22, 36...28, 41...36					
OPTIONAL ERV FILTERS						
Quantity...Size (in.)						
with 30 in. ERV	6...18x20					
with 36 in. ERV	2...20x20, 2...20x24					
with 41 in. ERV	2...12x24, 4...20x24					
OPTIONAL EXHAUST FAN						
Backward Curved ECM (mm)	350, 450 (High)					
Airfoil (in.)	—					
Backward Inclined (in.)	—					
Nominal cfm	450	600	750	900	1050	1200
Motor Hp Range	ECM, 1,1.5,2,3,5					

NOTE(S):

- a. For unit and component weights, refer to the latest edition of Carrier's Dedicated Outdoor Air Systems Builder. 10:1 gas heat not available for 75 MBH heater.
- b. XL gas heater only available in 10:1 modulation.
- c. Refer to the DOAS NG builder for the latest product data within the equipment submittal report. The above is to be used as reference only.
- d. Optional.

LEGEND

- ECM** — Electronically Commutated Motor
- ERV** — Energy Recovery Ventilator
- FPI** — Fins per Inch
- LP** — Liquid Propane
- OA** — Outdoor Air
- SCR** — Silicon-Controlled Rectifier

Table 5 – Physical Data – 62H, C-CL-CXL Cabinet^{a,b,c}

UNIT 62H C, CL, CXL CABINET	10	12	15	18	20	25	30	35
NOMINAL CAPACITY (TONS)	10	12	15	17.5	20	25	30	35
No. of Refrigerant Circuits	2							
Oil	Pre-Charged							
REFRIGERANT TYPE	R-454B							
OUTDOOR COIL								
Standard Efficiency Condenser (sq ft)	27			—		54		
High-Efficiency Condenser (sq ft)	—			54		—		
OUTDOOR FAN								
Standard Efficiency Condenser without ERV								
Quantity...Diameter (mm)	2...630			—		4...630		
Motor Hp	1.48			—		1.48		
High Efficiency Condenser without ERV								
Quantity...Diameter (mm)	—			4...630		—		
Motor Hp	—			1.48		—		
Standard Efficiency Condenser with ERV								
Quantity...Diameter (mm)	2...630			—		4...630		Use D Cabinet
Motor Hp	1.48			—		1.48		
High Efficiency Condenser with ERV								
Quantity...Diameter (mm)	—			4...630		—		Use D Cabinet
Motor Hp	—			1.48		—		
INDOOR COIL								
Face Area without ERV (sq ft)	7			10		12		16
Face Area with ERV (sq ft)	12			16			Use D Cabinet	
SUPPLY FAN								
Backward Curved ECM (mm)	350, 450 (High), 500 (Low), 500 (High) 460V only							
Airfoil (in.)	14, 16, 18, 20							
Backward Inclined (in.)	14, 16, 18, 20							
Nominal cfm 100% OA	1500	1800	2250	2700	3000	3750	4500	5250
Motor Hp Range	ECM, 1, 1.5, 2, 3, 5, 7.5, 10							
OPTIONAL HOT GAS REHEAT AND LIQUID SUBCOOLING COIL								
Face Area without ERV (sq ft)	7			10		12		16
Face Area with ERV (sq ft)	12			16			Use D Cabinet	
CONDENSATE DRAIN CONNECTION (NPT) (in.)	0.75							
OPTIONAL GAS HEAT SECTION								
Gas Input Sizes (Btuh x 1000)	75, 100, 150, 200, 250, 300, 350, 400							
Gas Input Sizes (Btuh x 1000) XL Cabinet	400, 600, 700, 800							
Control Type								
Stages (no. of stages)	2							
Stages XL Cabinet (no. of stages)	4							
Modulating (% range) ^b	5:1, 10:1 ^b							
Efficiency (Steady State) (%)	81							
Supply Line Pressure Range (in. wg)	5.0 min. - 13.5 max							
Rollout Switch Cutout Temp (°F)	350							
Gas Valve Quantity	1 Std - 2 with modulating option							
Manifold Pressure (in. wg)								
Natural Gas Std	3.5							
LP Gas Special Order	10							
OPTIONAL ELECTRIC HEAT								
Size Range (kW)	5, 10, 15, 20, 25, 30, 35, 40, 50, 60, 70, 80, 100							
Control Type								
Stages (no. of stages)	1, 2, 4							
SCR (% range) ^d	0 - 100							
OPTIONAL HOT WATER HEAT COIL WITH ERV	27.5 x 36.25, 4 row, 8 FPI (See Hot Water Coil Drawings)						Use D Cabinet	
OPTIONAL HOT WATER HEAT COIL WITHOUT ERV	27.5 x 36.25, 4 row, 8 FPI (See Hot Water Coil Drawings)							
OUTDOOR AIR FILTERS								
Quantity...Size (in.) with ERV								
Standard 2 in. MERV 8	2...16x25, 2...20x25			3...16x16, 6...16x20			Use D Cabinet	
Optional 4 in.								

Table 5 – Physical Data – 62H, C-CL-CXL Cabinet^{a,b,c} (cont)

UNIT 62H C, CL, CXL CABINET	10	12	15	18	20	25	30	35
NOMINAL CAPACITY (TONS)	10	12	15	17.5	20	25	30	35
MERV 8	2...16x25, 2...20x25			3...16x16, 6...16x20			Use D Cabinet	
MERV 11	2...16x25, 2...20x25			3...16x16, 6...16x20			Use D Cabinet	
MERV 13	2...16x25, 2...20x25			3...16x16, 6...16x20			Use D Cabinet	
Quantity...Size (in.) without ERV								
Standard 2 in. MERV 8	2...24x24			4...16x25	2,,,16x25, 2...20x25		3...16x16, 6...16x20	
Optional 4 in.								
MERV 8	2...24x24			4...16x25	2,,,16x25, 2...20x25		3...16x16, 6...16x20	
MERV 11	2...24x24			4...16x25	2,,,16x25, 2...20x25		3...16x16, 6...16x20	
MERV 13	2...24x24			4...16x25	2,,,16x25, 2...20x25		3...16x16, 6...16x20	
OPTIONAL ERV								
Type	Synthetic Polymer							
Diameter (in.)...depth (mm)	30...22, 36...28, 41...36, 46...46, 46...50						Use D Cabinet	
OPTIONAL ERV FILTERS								
Quantity...Size (in.)								
with 30 in. ERV	6...18x20						Use D Cabinet	
with 36 in. ERV	2...20x20, 2...20x24						Use D Cabinet	
with 41 in. ERV	2...12x24, 4...20x24						Use D Cabinet	
with 46 in. ERV	6...18x25						Use D Cabinet	
OPTIONAL EXHAUST FAN								
Backward Curved ECM (mm)	350, 450 (High), 500 (Low), 500 (High) 460V only							
Airfoil (in.)	14, 16, 18, 20							
Backward Inclined (in.)	14, 16, 18, 20							
Nominal cfm	1500	1800	2250	2700	3000	3750	4500	5250
Motor Hp Range	ECM, 1, 1.5, 2, 3, 5, 7.5, 10							

NOTE(S):

- a. For unit and component weights, refer to the latest edition of Carrier's Dedicated Outdoor Air Systems Builder. 10:1 gas heat not available for 75 MBH heater.
- b. XL gas heater only available in 10:1 modulation.
- c. Refer to the DOAS NG builder for the latest product data within the equipment submittal report. The above is to be used as reference only.
- d. Optional.

LEGEND

- ECM** — Electronically Commutated Motor
- ERV** — Energy Recovery Ventilator
- FPI** — Fins per Inch
- LP** — Liquid Propane
- OA** — Outdoor Air
- SCR** — Silicon-Controlled Rectifier

Table 6 – Physical Data – 62H, D-DXL Cabinet Sizes 20-35^{a,b,c}

UNIT 62H D, DXL CABINET	20	25	30	35
NOMINAL CAPACITY (TONS)	20	25	30	35
No. of Refrigerant Circuits	2			
Oil	Pre-charged			
REFRIGERANT TYPE	R-454B			
OUTDOOR COIL				
Standard Efficiency Condenser (sq ft)	—		54	
High-Efficiency Condenser (sq ft)	54		80	
OUTDOOR FAN				
Standard Efficiency Condenser without ERV				
Quantity...Diameter (mm)	—		4...630	
Motor Hp	—		1.48	
High Efficiency Condenser without ERV				
Quantity...Diameter (mm)	4...630		—	
Motor Hp	1.48		—	
Standard Efficiency Condenser with ERV				
Quantity...Diameter (mm)	—		4...630	
Motor Hp	—		1.48	
High Efficiency Condenser with ERV				
Quantity...Diameter (mm)	4...630		—	
Motor Hp	1.48		—	
INDOOR COIL				
Face Area without ERV (sq ft)	12		16	
Face Area with ERV (sq ft)	16		28.9	
SUPPLY FAN				
Backward Curved ECM (mm)	450 (High), 500 (Low), 500 (High) 460V only, 560-208/230V only, Dual 450 (High), Dual 500 (Low), Dual 500 (High)			
Airfoil (in.)	18, 20, 22, 25			
Backward Inclined (in.)	18, 20, 22, 25			
Nominal cfm 100% OA	3000	3750	4500	5250
Motor Hp Range	ECM, 1.5, 2, 3, 5, 7.5, 10, 15			
OPTIONAL HOT GAS REHEAT AND LIQUID SUBCOOLING COIL				
Face Area without ERV (sq ft)	12		16	
Face Area with ERV (sq ft)	16		28.9	
CONDENSATE DRAIN CONNECTION (NPT) (in.)	1			
OPTIONAL GAS HEAT SECTION				
Gas Input Sizes (Btuh x 1000)	100, 150, 200, 250, 300, 350, 400			
Gas Input Sizes (Btuh x 1000) XL Cabinet	400, 500, 600, 700, 800, 1000, 1200			
Control Type				
Stages (no. of stages)	2			
Stages XL Cabinet (no. of stages)	4			
Modulating (% range) ^b	5:1, 10:1 ^b			
Efficiency (Steady State) (%)	81			
Supply Line Pressure Range (in. wg)	5.0 min. - 13.5 max			
Rollout Switch Cutout Temp (°F)	350			
Gas Valve Quantity	1 Std - 2 with modulating option			
Manifold Pressure (in. wg)				
Natural Gas Std	3.5			
LP Gas Special Order	10			

Table 6 — Physical Data — 62H, D-DXL Cabinet Sizes 20-35^{a,b,c} (cont)

UNIT 62H D, DXL CABINET	20	25	30	35
NOMINAL CAPACITY (TONS)	20	25	30	35
OPTIONAL ELECTRIC HEAT				
Size Range (kW)	5, 10, 15, 20, 25, 30, 35, 40, 50, 60, 70, 80, 100, 110, 120			
Control Type				
Stages (no. of stages)	1, 2, 4			
SCR (% range)^d	0 - 100			
OPTIONAL HOT WATER HEAT COIL WITH ERV	40.5 x 47.5, 4 row, 8 FPI (See Hot Water Coil Drawings)			
OPTIONAL HOT WATER HEAT COIL WITHOUT ERV	40.5 x 47.5, 4 row, 8 FPI (See Hot Water Coil Drawings)			
OUTDOOR AIR FILTERS				
Quantity...Size (in.) with ERV				
Standard 2 in. MERV 8	3...16x16, 6...16x20	6...20x25, 3...25x25		
Optional 4 in.				
MERV 8	3...16x16, 6...16x20	6...20x25, 3...25x25		
MERV 11	3...16x16, 6...16x20	6...20x25, 3...25x25		
MERV 13	3...16x16, 6...16x20	6...20x25, 3...25x25		
Quantity...Size (in.) without ERV				
Standard 2 in. MERV 8	2...16x25, 2...20x25	3...16x16, 6...16x20		
Optional 4 in.				
MERV 8	2...16x25, 2...20x25	3...16x16, 6...16x20		
MERV 11	2...16x25, 2...20x25	3...16x16, 6...16x20		
MERV 13	2...16x25, 2...20x25	3...16x16, 6...16x20		
OPTIONAL ERV				
Type	Synthetic Polymer			
Diameter (in.)...depth (mm)	46...46, 46...50, 52...62, 64...88, 64...95, 68...100, 68...110			
OPTIONAL ERV FILTERS				
Quantity...Size (in.)				
with 46 in. ERV	6...18x25			
with 52 in. ERV	6...20x30			
with 64 in. ERV	10...16x36			
with 68 in. ERV	8...36x20			
OPTIONAL EXHAUST FAN				
Backward Curved ECM (mm)	450 (High), 500 (Low), 500 (High) 460V only, 560-208/230V only, Dual 450 (High), Dual 500 (Low), Dual 500 (High)			
Airfoil (in.)	18, 20, 22, 25			
Backward Inclined (in.)	18, 20, 22, 25			
Nominal cfm	3000	3750	4500	5250
Motor Hp Range	ECM, 1.5, 2, 3, 5, 7.5, 10, 15			

NOTE(S):

- a. For unit and component weights, refer to the latest edition of Carrier's Dedicated Outdoor Air Systems Builder.
- b. 10:1 modulating control available on DXL Cabinet (400-1200 MBtuh only). 5 kW SCR electric heater not available.
- c. Refer to the DOAS NG builder for the latest product data within the equipment submittal report. The above is to be used as reference only.
- d. Optional.

LEGEND

- ECM** — Electronically Commutated Motor
- ERV** — Energy Recovery Ventilator
- FPI** — Fins per Inch
- LP** — Liquid Propane
- OA** — Outdoor Air
- SCR** — Silicon-Controlled Rectifier

Table 7 – Physical Data – 62H, D-DXL Cabinet, Sizes 40-55^{a,b,c}

UNIT 62H D, DXL CABINET	40	45	50	55
NOMINAL CAPACITY (TONS)	40	45	50	55
No. of Refrigerant Circuits	2			
Oil	Pre-charged			
REFRIGERANT TYPE	R-454B			
OUTDOOR COIL				
Standard Efficiency Condenser (sq ft)	54	80		
High-Efficiency Condenser (sq ft)	—	—		
OUTDOOR FAN				
Standard Efficiency Condenser without ERV				
Quantity...Diameter (mm)	4...630	6...630		
Motor Hp	1.48			
High Efficiency Condenser without ERV				
Quantity...Diameter (mm)	—			
Motor Hp	—			
Standard Efficiency Condenser with ERV				
Quantity...Diameter (mm)	Use E Cabinet (62L)			
Motor Hp	—			
High Efficiency Condenser with ERV				
Quantity...Diameter (mm)	Use E Cabinet (62L)			
Motor Hp	—			
INDOOR COIL				
Face Area without ERV (sq ft)	28.9			
Face Area with ERV (sq ft)	—			
SUPPLY FAN				
Backward Curved ECM (mm)	450 (High), 500 (Low), 500 (High) 460V only, 560-208/230V only, Dual 450 (High), Dual 500 (Low), Dual 500 (High)			
Airfoil (in.)	18, 20, 22, 25			
Backward Inclined (in.)	18, 20, 22, 25			
Nominal cfm 100% OA	6000	6750	7500	8250
Motor Hp Range	ECM, 1.5, 2, 3, 5, 7.5, 10, 15			
OPTIONAL HOT GAS REHEAT AND LIQUID SUBCOOLING COIL				
Face Area without ERV (sq ft)	28.9			
Face Area with ERV (sq ft)	—			
CONDENSATE DRAIN CONNECTION (NPT) (in.)	1			
OPTIONAL GAS HEAT SECTION				
Gas Input Sizes (Btuh x 1000)	100, 150, 200, 250, 300, 350, 400			
Gas Input Sizes (Btuh x 1000) XL Cabinet	400, 500, 600, 700, 800, 1000, 1200			
Control Type				
Stages (no. of stages)	2			
Stages XL Cabinet (no. of stages)	4			
Modulating (% range) ^b	5:1, 10:1 ^b			
Efficiency (Steady State) (%)	81			
Supply Line Pressure Range (in. wg)	5.0 min. - 13.5 max			
Rollout Switch Cutout Temp (°F)	350			
Gas Valve Quantity	1 Std - 2 with modulating option			
Manifold Pressure (in. wg)				
Natural Gas Std	3.5			
LP Gas Special Order	10			
OPTIONAL ELECTRIC HEAT				
Size Range (kW)	5, 10, 15, 20, 25, 30, 35, 40, 50, 60, 70, 80, 100, 110, 120			
Control Type				
Stages (no. of stages)	1, 2, 4			
SCR (% range) ^d	0 - 100			
OPTIONAL HOT WATER HEAT COIL WITH ERV	Use E Cabinet (62L)			
OPTIONAL HOT WATER HEAT COIL WITHOUT ERV	40.5 x 47.5, 4 row, 8 FPI (See Hot Water Coil Drawings)			

Table 7 – Physical Data – 62H, D-DXL Cabinet, Sizes 40-55^{a,b,c} (cont)

UNIT 62H D, DXL CABINET	40	45	50	55
NOMINAL CAPACITY (TONS)	40	45	50	55
OUTDOOR AIR FILTERS				
Quantity...Size (in.) with ERV				
Standard 2 in. MERV 8	—			
Optional 4 in.				
MERV 8	—			
MERV 11	—			
MERV 13	—			
Quantity...Size (in.) without ERV				
Standard 2 in. MERV 8	6...20x25, 3...25x25			
Optional 4 in.				
MERV 8	6...20x25, 3...25x25			
MERV 11	6...20x25, 3...25x25			
MERV 13	6...20x25, 3...25x25			
OPTIONAL ERV				
Type	Use E Cabinet (62L)			
OPTIONAL EXHAUST FAN				
Backward Curved ECM (mm)	450 (High), 500 (Low), 500 (High) 460V only, 560-208/230V only, Dual 450 (High), Dual 500 (Low), Dual 500 (High)			
Airfoil (in.)	18, 20, 22, 25			
Backward Inclined (in.)	18, 20, 22, 25			
Nominal cfm	6000	6750	7500	8250
Motor Hp Range	ECM, 1.5, 2, 3, 5, 7.5, 10, 15			

NOTE(S):

- For unit and component weights, refer to the latest edition of Carrier's Dedicated Outdoor Air Systems Builder.
- 10:1 modulating control available on DXL Cabinet (400-1200 MBtuh only). 5 kW SCR electric heater not available.
- Refer to the DOAS NG builder for the latest product data within the equipment submittal report. The above is to be used as reference only.
- Optional.

LEGEND

- ECM** — Electronically Commutated Motor
- ERV** — Energy Recovery Ventilator
- FPI** — Fins per Inch
- LP** — Liquid Propane
- OA** — Outdoor Air
- SCR** — Silicon-Controlled Rectifier

Step 5 — Field Fabricate Ductwork

The unit is not designed to support the weight of ductwork. Ductwork must be constructed in a fashion that is self-supporting. Ductwork for curb-mounted units should be attached to the curb prior to setting the unit, and may not be attached to the bottom of the unit.

Units ordered in a horizontal discharge are supplied with flanges to attach ductwork. Neither the flanges nor exterior skin of the unit are capable of supporting the load of the ductwork. Ductwork support must come from the structure itself that the unit is servicing. Ductwork passing through unconditioned spaces must be insulated (including a vapor barrier) to prevent unnecessary energy losses and/or condensation.

If a plenum return is used on a vertical unit, the return should be ducted through the roof deck to comply with applicable fire codes. A minimum clearance is not required around ductwork.

DUCTWORK CONSIDERATIONS

The unit has been designed to operate at the specific air volume and external static pressure that was ordered. This static pressure is generated by any additional components that are added to the unit (i.e., ductwork, etc). Additional static pressure beyond that ordered will affect the performance of the packaged air conditioning unit and lessen the air volume that can be delivered.

Proper engineering methods need to be employed when calculating duct and component static pressure (i.e., 2017 ASHRAE Handbook - Fundamentals, Chapter 21). The system ductwork must comply with Sheet Metal and Air Conditioning Contractors National Association (SMACNA) or any other recognized standards.

It is recommended that flexible duct connections be incorporated into the ductwork design to prevent the transmission of any vibrations, either mechanical or harmonic.

As a general rule, all ducts should have a straight run of at least 3 hydraulic duct diameters immediately before and after the unit before adding any fittings, elbows, restrictions, etc.

Hydraulic duct diameter for round ducts (in inches):

$$Dh = d$$

Dh: hydraulic diameter

d: round duct inside diameter

Hydraulic duct diameter for rectangular ducts (in inches):

$$Dh = (2 * H * W) / (H + W)$$

Dh: hydraulic diameter

H: rectangular duct inside height

W: rectangular duct inside width

RETURN AIR DUCTWORK

Return air ductwork height and width must be no smaller than the unit return air opening height and width.

DISCHARGE DUCTWORK

Discharge air ductwork height and width must be no smaller than the unit discharge air opening height and width.

Step 6 — Make Unit Duct Connections

All 62HB, C, D, F, G, H, U, V, X, Y, 7, and 8 units bring in 100% outdoor air through the outdoor air intake hood and do not have a return air connection. The 62HA, B, C, D, U, V, 7, and L units have a vertical supply duct opening in the bottom of the unit. The 62HF, G, H, X, Y, 8, and 9 units have a horizontal supply duct opening in the side of the unit.

All 62HK, L, M, N, Q, R, S, Z, 2, 3, 4, 5, 6, and 9 units bring in 100% outside air through the intake hood and also have a return duct opening in the bottom of the unit for exhaust. They will also be equipped with a factory-installed power exhaust and may be equipped with an energy recovery ventilator (ERV) and/or an energy conservation wheel. The return air to these units is not recirculated or mixed with the incoming outdoor air. The return air may be used to transfer energy to the incoming air via the energy recovery ventilator and is then exhausted. The 62HK, M, N, 2, 3, and L units have a vertical supply and return duct opening in the bottom of the unit. The 62HQ, R, S, 5, 6, and 9 units have a horizontal supply duct opening in the side of the unit and a vertical return opening in the bottom of the unit. To determine the specifics regarding a particular unit, see the model number nomenclature found in the product data guide for the 62H unit.

VERTICAL SUPPLY/RETURN CONNECTIONS

For vertical supply or return connections, ductwork openings are shown in the DOAS Builder generated submittal. Attach the ductwork to the roof curb. Do not attach duct directly to the unit.

⚠ WARNING

PERSONAL INJURY HAZARD

Failure to follow this warning could cause personal injury.

For vertical supply and return units, tools or parts could drop into ductwork and cause an injury. Install a 90 degree turn in the return ductwork between the unit and the conditioned space. If a 90 degree elbow cannot be installed, then a grille of sufficient strength and density should be installed to prevent objects from falling into the conditioned space. Due to electric heater, supply duct will require 90 degree elbow.

HORIZONTAL SUPPLY CONNECTIONS

For horizontal supply connections, ductwork openings are shown in the DOAS Builder generated submittal. The 62H Series units do not have horizontal return connections.

Step 7 — Install External Trap for Evaporator Condensate Drain

The unit's condensate drain connection is located on the side of the unit (3/4 in. condensate drain connection on B and C cabinet units; 1 in. condensate drain connection on D cabinet units). Refer to the DOAS Builder generated submittal for condensate location.

All units must have an external trap for condensate drainage. Install a trap following "A" and "B" dimensions at minimum (see Fig. 9). Protect trap against freeze-up to avoid trap damage. If drain line is installed downstream from the external trap, pitch the line away from the unit at minimum 1/8 in. per 1 ft of run. Use a higher pitch on the line if required by local code.

Do not use a pipe size smaller than the unit connection. Refer to the physical data tables starting on page 19 for condensate drain connection sizes. Failure to follow these guidelines could cause condensate not to drain properly, and potential intrusion of water into the space and/or other negative effects. It is also recommended to pre-prime traps before initial operation, or long shutdown periods. Open vents and drain plugs are recommended. See Fig. 9 for drain piping details.

Minimum Trap Depth
Should Be Based On:

A" = TSP + 1"
B" = A + (A ÷ 2)

Example:

A = 4" + 1" B = 5 + (5 ÷ 2)
A = 5" B = 7.5"

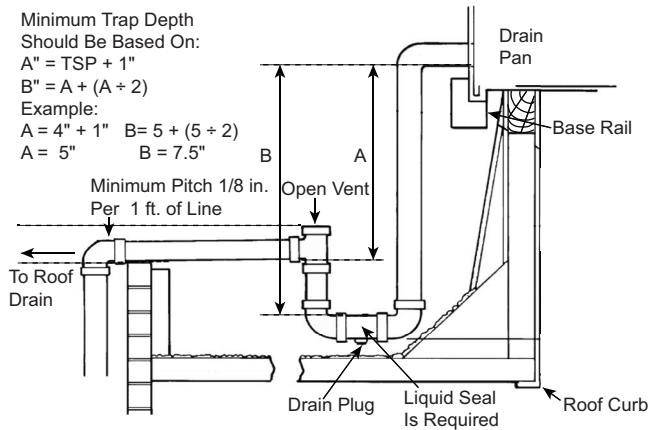

NOTE(S):

- Trap should be deep enough to offset maximum unit static difference. (See submittal and calculate the trap depth based on the above.)
- TSP = Total Static Pressure

Fig. 9 – Condensate Drain Piping Details

Step 8 – Install Gas Piping (Gas Heat Units Only)

62H Series unit heaters are only designed to work with Natural Gas. A special order is available for liquid propane (LP).

B, C, CL, AND D CABINETS

When equipped with gas heat, the above cabinets only use a single heater. Units with a single heater will include a panel knockout for the gas piping connections.

CXL, DXL CABINETS

When equipped with gas heat, the above cabinets only two heaters. Units with two heaters require a field knockout for the gas heat piping connection and require a field fabricated and installed gas pipe manifold to connect the two heaters to the main gas supply line.

See Table 9 for gas manifold sizes and pressures. Refer to local building codes, or in the absence of local codes, to ANSI. Z223.1-latest year and addendum Z223.1A-latest year entitled HFGC. In Canada, installation must be in accordance with the CAN1.B149.1 and CAN1.B149.2 installation codes for gas burning appliances.

Gas piping length and capacity is shown in Table 8. See Fig. 10 for typical pipe guide and locations of external manual gas shutoff valve. Gas supply piping must be supported starting from connection of the unit. If long stretches of piping are expected to be used, there must be supports at intervals of every 6 to 8 ft Metal straps, blocks, or hooks are acceptable to support the gas piping. The piping should never be strained or bent.

Table 8 – Gas Piping Capacity (cubic ft per hr)

GAS PIPE LENGTH (ft)	PIPE SIZE (in.)				
	3/4	1	1-1/4	1-1/2	2
10	278	520	1050	1600	2700
20	190	350	730	1100	2100
30	152	285	590	890	1650
40	130	245	500	760	1450
50	115	215	440	670	1270
60	105	195	400	610	1105
70	96	180	370	560	1050
90	84	160	320	490	930
100	79	150	305	460	870
125	72	130	275	410	780
150	64	120	250	380	710
175	59	110	225	350	650
200	55	100	210	320	610

⚠ WARNING

Do not pressure test gas supply while connected to unit. Always disconnect union before servicing. High pressures can cause gas valve damage resulting in a hazardous condition.

IMPORTANT: Natural gas pressure at unit gas connection must not be less than 5.0 in. wg or greater than 13.0 in. wg for all heat sizes.

Install field-supplied manual gas shutoff valve with a 1/8 in. NPT pressure tap for test gauge connection at unit. The pressure tap is located on the gas manifold, adjacent to the gas valve. Field gas piping must include sediment trap and union (see Fig. 10). Install a field-supplied gas regulator. See Table 9 for gas manifold sizes and pressures.

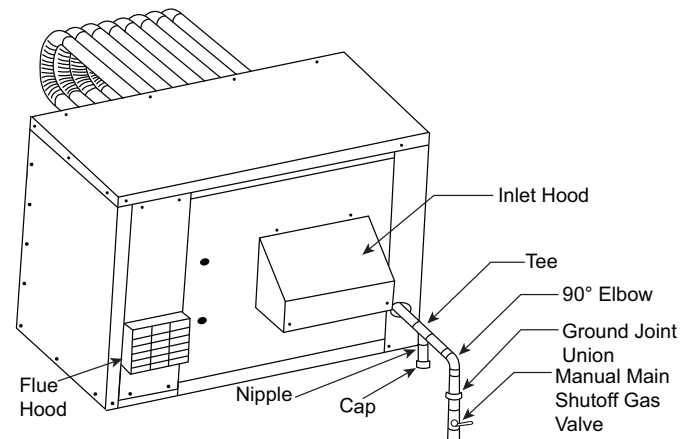

Fig. 10 – Gas Heat Section (Single Heater Unit)

Table 9 — Gas Heat Connection Sizes and Pressures^a

INDIV. GAS HEATER INPUT (MBH)	GAS NPT CONNECTION (in.)	MIN. INLET GAS PRESSURE	
		NG in. wg (MBAR)	LPG in. wg (MBAR)
75	0.75	5.0 (12.5)	11.0 (27.4)
100	0.75	5.0 (12.5)	11.0 (27.4)
150	0.75	5.0 (12.5)	11.0 (27.4)
200	0.75	5.0 (12.5)	11.0 (27.4)
250	0.75	5.0 (12.5)	11.0 (27.4)
300	0.75	5.0 (12.5)	11.0 (27.4)
350	0.75	5.0 (12.5)	11.0 (27.4)
400	1.00	6.0 (14.9)	12.0 (29.9)
500	1.00	6.0 (14.9)	12.0 (29.9)
600	1.00	6.0 (14.9)	12.0 (29.9)

NOTE(S):

a. Size gas-supply piping for 0.3 in. wg maximum pressure drop. Do not use supply pipe smaller than unit gas connection.

LEGEND

LPG — Liquid Propane Gas
 NG — Natural Gas

GAS HEAT SAFETY CONTROLS

Safety systems are required for proper performance of the gas heater. The gas heater shall not be permitted to operate with any safety system disabled. If a fault is found in any of the safety systems, then the system shall be repaired only by a contractor qualified in the installation and service of gas-fired heating equipment.

- **Combustion Airflow Switch:** An airflow switch is provided as part of the control system to verify airflow through an induced draft fan by monitoring the difference in pressure between the fan and the atmosphere. If sufficient negative pressure is not present, indicating lack of proper air movement through heat exchange, the switch opens, shutting off gas supply through the ignition control module. The air pressure switch has fixed settings and is not adjustable.
- **Rollout Switch (Manual Reset):** The heater is equipped with manual reset rollout switch(es) in the event of burner flame rollout. The switch will open on temperature rise and shut off gas supply through the ignition control module. Flame rollout can be caused by insufficient airflow for the burner firing rate (high gas pressure), blockage of the vent system, or in the heat exchanger. The heater should not be placed back in operation until the cause of the rollout condition is identified. The rollout switch can be reset by pressing the button on top of the switch.
- **Primary High Limit Switch:** To prevent the heater from operating under low airflow conditions, the unit is equipped with a fixed temperature high limit switch, mounted on the vestibule panel. This switch will shut off gas to the heater through the ignition control module before the air temperature reaches 250°F (121.1°C). Reduced airflow may be caused by restrictions upstream or downstream of the circulating air blower, such as dirty or blocked filters or restriction of the air inlet or outlet to the unit. The high limit switch will shut off the gas when the temperature reaches its set point and then resets when the temperature drops 30°F (16.7°C) below the set point, initiating a heater ignition. The heater will continue to cycle on limit until the cause of the reduced air flow is corrected.
- **Ignition Control Module:** Ignition control modules are available with a number of different operating functions. Refer to the Sequence of Operation and Control Diagnostic data sheets, provided in the instructions package, for a detailed description of the control features, operation, and troubleshooting for the model control installed.

Step 9 — Install Gas Heat Condensate Drain

Units with natural gas or LP heat also require a condensate drain for heater condensate collection. Condensate in gas heaters can occur during low operating temperatures or during heater start-up.

The unit’s gas heat condensate drain connection is located on the side of the unit. Refer to the DOAS Builder generated submittal for condensate location.

All units must have an external trap for condensate drainage. Install a trap following “A” and “B” dimensions at minimum (refer to Fig. 9). Protect trap against freeze-up to avoid trap damage. If drain line is installed downstream from the external trap, pitch the line away from the unit at minimum 1/8 in. per 1 ft of run. Use higher pitch on the line if required by local code. Do not use a pipe size smaller than the unit connection. Refer to the physical data tables starting on page 19 for condensate drain connection sizes. Failure to follow these guidelines could cause condensate not to drain properly, and potential intrusion of water into the space and/or other negative effects. It is also recommended to pre-prime traps before initial operation, or long shutdown periods. Open vents and drain plugs are recommended. Refer to Fig. 9 for drain piping details.

NOTE: Check with local codes for any requirements for draining of gas heat condensate. Also verify any compatibility issues with roofing material or roof warranty and gas heat condensate disposal.

Step 10 — Install Hot Water (Hot Water Units Only)

Coils should be piped according to any relevant local codes. All external piping must be supported independently from the coil. External piping must be insulated to prevent freeze up. See Table 10 for hot water coil connection sizes. Control valves for hot water coils are to be field provided and installed. Coil freeze protection operation (open HW valve when coil temp approaches freeze limit) must be field provided.

Table 10 — Hot Water Coil Connections

CABINET	ERV	HOT WATER COIL CONNECTION (Sweat, in.)
B	No	1-5/8
	Yes	1-5/8
C / CL / CXL	No	1-5/8
	Yes	1-5/8
D / DXL	No	3-1/8
	Yes	3-1/8

HOT WATER COIL PIPE ROUTING

The piping for the hot water coil can be routed either through the bottom of the unit or through the side of the cabinet (see Fig. 11). The contractor must make a hole for the supply and return water pipes and seal it appropriately.

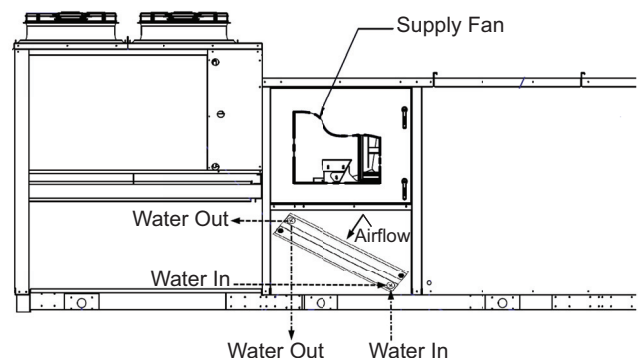

Fig. 11 — Hot Water Coil Pipe Routing Options

HOT WATER HEATING CONTROL

The control valve for units equipped with hot water coils is to be field provided and installed. The control valve will also require field provided power (not from unit). The control signal for the control valve will be provided by the ALC controller by wiring the valve input signal to UO-6 (0 to 10-v signal). Valve selection is to be determined by power requirements, pipe size, and water flow and temperature. See Fig. 12 for control valve wiring example.

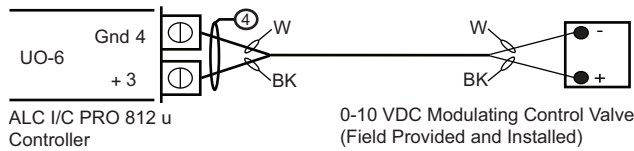

Fig. 12 — Hot Water Coil - Control Valve Wiring

Step 11 — Make Electrical Connections

For units without the factory-installed disconnect, power wiring should be connected to the main power terminal block located within the unit main control section. The power wiring connections on units with non-fused factory disconnects should be made at the line side of the disconnect switch.

The internal power and control wiring of these units is factory-installed and each unit is thoroughly tested prior to shipment. See Fig. 16 for the typical wiring diagram. Standard 62H Series units have an SCCR (short circuit current rating) of 5KA. A higher SCCR rating is available as a special order. Consult the unit nameplate to verify SCCR rating. Contact the local service representative if assistance is required.

It is recommended that an independent 115-v power source be brought to the vicinity of the rooftop unit for portable lights and tools used by the service mechanic, if a factory-installed convenience outlet is not on the unit.

OPTIONAL UNIT-POWERED TYPE CONVENIENCE OUTLET

A unit-mounted transformer is factory-installed to step down the main power supply voltage to the unit to 115-v at the duplex receptacle. This option also includes a manual switch with fuse, located in a utility box and mounted on a bracket behind the convenience outlet. The primary leads to the convenience outlet transformer are not factory-connected. Selection of primary power source is a customer option. If national or local codes permit, the transformer primary leads can be connected at the line-side terminals on the unit-mounted non-fused disconnect (if equipped); this will provide service power to the unit when the unit disconnect switch is open. Other connection methods will result in the convenience outlet circuit being de-energized when the unit disconnects.

⚠ WARNING

Depending on how the convenience outlet and transformer are wired, they may remain HOT regardless of the disconnect switch on/off positions. Before performing service or maintenance operations on unit, turn off main power switch to unit. Electrical shock could cause personal injury.

OPTIONAL NON-UNIT-POWERED TYPE (FIELD WIRED) CONVENIENCE OUTLET

This type requires the field installation of a general-purpose 125-v 15-A circuit powered from a source elsewhere in the building. Observe national and local codes when selecting wire size, fuse or breaker requirements and disconnect switch size and location, Route 125-v power supply conductors into the bottom of the utility box containing the duplex receptacle.

FIELD POWER SUPPLY

The units are factory wired for the voltage shown on the nameplate. Main power wiring should be sized for the minimum wire ampacity shown on the nameplate. An external weather-tight disconnect switch properly sized for the unit total load is required for each unit. Disconnect must be installed in accordance with local and/or national electric codes. This disconnect can be supplied by the factory or by others.

Power wiring may enter the rooftop unit through the unit base and roof curbs on all models. Install conduit connectors at the entrance locations. External connectors must be weatherproof.

All units must be properly grounded. The ground lug is provided for this purpose. **DO NOT** use the ground lug for connecting a neutral conductor. The unit must be electrically grounded in accordance with local codes, or in the absence of local codes, with the NEC (National Electrical Code) ANSI/NFPA (National Fire Protection Association) 70 1981.

Once it is established that supply voltage is within the utilization range, check and calculate if an unbalanced condition exists between phases.

Use the following formula to determine the percent of voltage imbalance.

$$\% \text{ Voltage imbalance} = 100 \times \frac{\text{max voltage deviation from average voltage}}{\text{average voltage}}$$

Example: Supply voltage is 460-3-60.

AB = 452-v
BC = 464-v
AC = 455-v

$$\text{Average Voltage} = \frac{452 + 464 + 455}{3} = \frac{1371}{3} = 457$$

Determine maximum deviation from average voltage.

$$(AB) 457 - 452 = 5\text{-v}$$

$$(BC) 464 - 457 = 7\text{-v}$$

$$(AC) 457 - 455 = 2\text{-v}$$

Maximum deviation is 7-v.

Determine percent of voltage imbalance.

$$\% \text{ Voltage Imbalance} = 100 \times (7 / 457) = 1.53\%$$

This amount of phase imbalance is satisfactory as it is below the maximum allowable 2%.

IMPORTANT: If the supply voltage phase imbalance is more than 2%, contact your local electric utility company immediately.

Unit failure as a result of operation on improper line voltage or excessive phase imbalance constitutes abuse and may cause damage to electrical components.

Consult the wiring diagram furnished with the unit. These packaged units are manufactured for each application selection. The unit wiring diagram is located inside the control panel of each unit.

When installing units without a factory-installed disconnect, provide disconnect per NEC Article 440 or local codes. For non-fused disconnects, size the disconnect according to the sizing data provided on unit nameplate. If a fused disconnect is used, determine the minimum size for the switch based on the disconnect sizing data and then coordinate the disconnect housing size to accommodate the maximum overcurrent protection (MOCP) device size as marked on the unit informative plate. All field wiring must comply with NEC and local codes. Size wire based on MCA (minimum circuit amps) on the unit informative plate. See Fig. 16 for typical installation wiring diagrams.

⚠ CAUTION

The correct power phasing is critical to the operation of the scroll compressors. An incorrect phasing will result in an alarm being generated and compressor operation lockout. Should this occur, power phase correction must be made to the incoming power. Damage to compressor could result.

⚠ WARNING

Unit cabinet must have an uninterrupted, unbroken electrical ground to minimize the possibility of personal injury if an electrical fault should occur. This ground may consist of electrical wire connected to unit ground lug in control compartment, or conduit approved for electrical ground when installed in accordance with NEC; ANSI/NFPA, latest edition, and local electrical codes. *Do not use gas piping as an electrical ground.* Failure to follow this warning could result in the installer being liable for personal injury of others.

⚠ WARNING

Disconnect all power to the unit before performing maintenance or service. Unit may automatically start if power is not disconnected. Failure to follow this warning could cause personal injury, death, and/or equipment damage.

SENSOR WIRING

The 62H Series unit uses a variety of sensors for control purposes. The sensors provided will depend upon the features of the unit as detailed below.

All units are equipped with an outdoor air sensor (OAT) and a combination of supply air temperature (SAT) and duct relative humidity sensor.

The combination sensor should be installed in the supply duct downstream of the heat section. The sensor must be far enough downstream of the heat section so that the discharge air is adequately mixed for proper sensing. If the unit is not equipped with heat, the combination sensor is factory-installed in the cabinet. The sensor is connected to the unit controller as indicated in the wiring diagram with 18 AWG (American Wire Gauge) shielded wire. Do not run the sensor wiring in the same conduit as high voltage wiring.

A zone temperature sensor (ZS) may be provided as an accessory with units that have ordered the space temperature override control function. The ZS should be installed in the space and connected to the unit controller at the Rnet connection as shown in the wiring diagram. See Tables 11 and 12 for Rnet wiring specifications.

Use the specified type of wire and cable for maximum signal integrity shown in Table 11.

To wire the sensor to the controller:

1. Partially cut, then bend and pull off the outer jacket of the Rnet cable(s), being careful not to nick inner insulation.
2. Strip about 1/4 in. of the inner insulation from each wire (see Fig. 13).
3. Wire each terminal on the sensor to the same terminal on the controller. Table 12 shows the recommended Rnet wiring scheme.

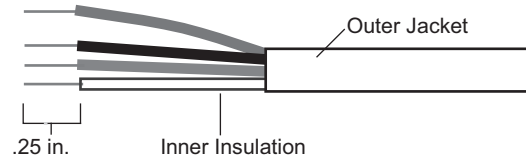

Fig. 13 – Rnet Cable Wire

Table 11 – Rnet Wiring Specifications

RNET WIRING SPECIFICATIONS	
Description	4 conductor, unshielded, CMP, plenum rated cable
Conductor	18 AWG
Maximum Length	500 ft
Recommended Coloring	Jacket: white Wiring: black, white, green, red
UL Temperature	32°F to 167°F
Voltage	300-vac, power limited
Listing	UL: NEC CL2P (or better)

LEGEND

- AWG** — American Wire Gauge
- CMP** — Communications Plenum Cable
- NEC** — National Electrical Code
- UL** — Underwriters Laboratories

Table 12 – Rnet Wiring^a

WIRE	TERMINAL
Red	+12-v
Black	Rnet-
White	Rnet+
Green	Gnd

NOTE(S):

- a. The wire should be connected to the terminal shown.

A2L REFRIGERANT LEAK DETECTION SYSTEM INTERLOCK

Certain applications may require interlocking the DOAS system to field devices that will need to open when the unit initiates A2L dissipation mode. Examples of these devices but not limited to are:

- Fire Dampers
- VAV Dampers

If the DOAS supply air ductwork is connected to the return or OA intake of a separate RTU or other HVAC system, the RTU or other HVAC system will need to be enabled.

When one or both A2L refrigerant leak sensors (A2LGS1 or A2LGS2 sensors) are activated due to a leak, the NO contact in the A2LR will close, therefore initiating A2L dissipation mode. Unit will automatically shut down and remove high-voltage power to major components. The supply fan and exhaust fan (if equipped) will continue running.

Refer to the latest Controls, Operation, Start-up, and Troubleshooting manual for further details.

Step 12 — Open Exhaust Damper (Units with Optional Exhaust or Energy Conservation Wheel Only)

The optional exhaust damper is secured to the exhaust assembly for shipping. Remove the two screws holding the damper to the panel. Damper should be free to swing open during operation. See Fig. 14 for exhaust damper example.



Fig. 14 — Optional Exhaust Damper

Step 13 — Install all Accessories

After all of the factory-installed options have been adjusted, install all of the field-installed accessories. Refer to the accessory installation instructions included with each accessory.

Step 14 — Configure Controls

The unit controller is pre-configured with default set points as detailed below. If changes to the set points are desired, this may be accomplished via the factory-installed Equipment Touch™ device (see Fig. 15). See the Controls, Operation, Start-up, and Troubleshooting manual for wiring and instructions.

NOTE: Rev H and J 62H units are compatible with the Equipment Touch 2 (P/N: EQT2) and not with the previous version Equipment Touch (P/N: EQT1).



Fig. 15 — Equipment Touch 2

SEQUENCE OF OPERATION

100% outdoor air units — 62H

The 62H Series unit is designed to condition 100% outdoor air to room neutral conditions for ventilation purposes. As such, the 62H unit is not designed to, nor will the 62H unit maintain space cooling, heating or relative humidity conditions. A separate ancillary device must be installed to provide primary space heating, cooling, and humidity control.

The controller is turned on by a switch located on its front, upper left corner. Several occupancy control options are available for starting the unit. These can be selected from the Equipment Touch display pad on the Controls screen (requires user password). The Resident Program has an adjustable scheduler that uses the internal time clock to allow for separate Sequences for Occupied and Unoccupied periods. This can be accessed from the Equipment Touch display pad on the Schedules screen (requires user password).

NOTE: All temperature-related events have an additional 10-second (fixed) “delay on make” to allow temperatures to settle.

OCCUPIED MODE

When the Equipment Touch Schedule calls for the start of the Occupied mode, and the controller has verified that there are no fault or shutdown conditions, after a 30-second (fixed) delay the unit goes into Occupied mode.

Outdoor Air Damper (OD)

After the unit goes into Occupied mode, the Outdoor Air (OA) damper will open. As the OA damper opens, the Outdoor Air Damper Actuator (OADA) auxiliary switches close. The OA damper stays open until the system reaches the end of the Occupied mode period. It will remain open until the supply fan turns off. After the supply fan turns off, the OA damper will close.

Supply Fan (SF)

As the OA damper opens, the OADA auxiliary switch (adjustable) will close and the SF will turn on. The SF shall operate continuously while the unit is in the Occupied mode. When the system reaches the end of the Occupied mode period, the SF will continue to run for an additional 2 minutes before turning off.

The SF will operate based on one of four control methods, depending on the unit and control configuration.

Constant Volume (CV)

The unit will operate the SF at full speed or the commanded manual override speed.

Duct Pressure Control (VAV-DPT)

The unit will operate the SF to maintain the supply duct pressure set point.

Air Monitor Control (VAV-AMS)

The unit will operate the SF to maintain the SF airflow set point.

- Space Pressure Control (VAV-SPT)
- The unit will operate the SF to maintain the space pressure set point (special order).

Exhaust fan (EF)

At the same time the SF turns on, the EF will be enabled to run. The EF shall be enabled to run continuously while the unit is in the Occupied mode. When the system reaches the end of the Occupied mode period, the EF will be enabled to run for an additional 2 minutes before turning off.

The EF will operate based on one of three control methods, depending on the unit and control configuration.

Constant Volume (CV)

- The unit will operate the EF at full speed or the commanded manual over-ride speed.

Space Pressure Control (VAV-SPT)

- The unit will operate the EF to maintain the space pressure set point.

Air Monitor Control (VAV-AMS)

- The unit will operate the EF to maintain the EF airflow set point.

Energy Conservation Wheel (ECW)

After the OA damper opens and the SF turns on, the ECW turns on. The ECW Bypass Damper will open when the ECW is off and it will close when the ECW is on.

- *ECW with VFD Controlled Defrost (WM-VFD)* — When the OAT is 3°F (adjustable) or more above or below the RAT, the ECW will be on. It will be off, if the OAT is less than 3°F (adjustable) above or below the RAT. It will decrease speed or stop as the WExAT goes below 25°F (adjustable) to allow for wheel defrosting. It will start back up and increase speed when the WExAT rises toward 25°F (adjustable) or more.

Cooling Mode

Cooling mode is available when the Entering Coil Air Temperature (ECAT) is above the ECAT cooling lower limit (55°F, adjustable) and there is a demand for cooling. When the Entering Coil Air Temperature (ECAT) is 1°F (adjustable) or more above the Supply Air Temperature (SAT) cooling set point (70°F, adjustable), compressor No. 1 turns on. When the SAT is 2°F (adjustable) or more above the SAT cooling set point (70°F, adjustable), compressor No. 2 turns on — not less than 10 minutes (adjustable) after compressor No. 1 turned on. When the SAT is 2°F (adjustable) or more below the SAT cooling set point (70°F, adjustable), compressor No. 2 turns off. When the ECAT is 1°F (adjustable) or more below the Supply Air Temperature (SAT) cooling set point (70°F, adjustable), compressor No. 1 turns off.

- *Variable Speed Compressors (Size 40-140)* — The controller regulates the capacity of the variable speed lead compressor with a 0-10 vdc output signal that controls the VFD's output to the compressor, resulting in an increase or decrease of the compressors motor speed. The variable speed compressor will modulate based upon the Supply Air Temperature (SAT) sensor and set point (70°F, adjustable). The compressor will ramp up to 100% once an hour, for 60 seconds, to push oil back to the compressor. The hot gas reheat circuit and subcooling circuits (if present), will be enabled for the duration of the oil purge. If the DX LAT drops to 38°F or less for 10 minutes, the controller will issue an alarm and the compressor stops. When the DX LAT warms back up to 55°F or more, the compressor turns back on. If there is a current call for first stage cooling and compressor no. 1 is shut down due to an alarm (HPS1, LPS1, or DX LAT1), compressor No. 2 will be turned on to take its place until it returns.
- *Hot Gas Reheat (HGRH) – Modulating* — When the SAT is 1°F (adjustable) or more below the SAT cooling set point, HGRH turns on and modulates to maintain the SAT cooling set point. When the SAT is 2°F (adjustable) or more above the SAT cooling set point, HGRH turns off.

Dehumidification Mode

Dehumidification Mode is available if the ECAT is 1°F (fixed) above the dehumidification lower limit of 60°F (adjustable) and there is no call for heating. When the Entering Coil Air Dew Point (ECDP) is 1°F (adjustable) or more above the Supply Air Dew Point (SADP) set point (55°F, adjustable), dehumidification mode is enabled. After the minimum time-off delay, compressor No. 1 turns on.

When the SADP is 2°F (adjustable) or more above the SADP set point, and after minimum time-off delay, compressor No. 2 turns on — not less than 10 minutes (adjustable) after compressor No. 1 turns on.

When the SADP is 1°F (adjustable) or more below the SADP set point, compressor No. 2 turns off. When ECDP is 2°F (adjustable) or more below the SADP set point, compressor No. 1 turns off and dehumidification mode is disabled.

- *Variable Speed Compressor (Size 40-140)* — The variable speed compressor will modulate based upon the DX Leaving Air Temperature (DX LAT) sensor and set point (55°F, adjustable). See Variable Speed. Freeze protection, oil purge, and back-up sequence are also in effect. See Cooling sequence for details.
- *Hot Gas Reheat (HGRH) – Modulating* — When the SAT is 1°F (adjustable) or more below the SAT cooling set point, HGRH turns on and modulates to maintain the SAT cooling set point. When the SAT is 2°F (adjustable) or more above the SAT cooling set point, HGRH turns off.
- *Liquid Subcooling Reheat (LSRH)* — If equipped when either of the compressor are enabled during dehumidification mode, the subcooling coil is enabled. When the compressors are disabled, the subcooling coil is disabled.

Zone Air Temperature Reset (Optional)

ZAT/SAT Set Point Reset is selectable using the Equipment Touch display pad or Building Automation System (BAS) (default is "OFF"). As the ZAT goes above the ZAT cooling set point, the SAT cooling set point will decrease by a ratio (adjustable) in order to lower the ZAT. As the ZAT goes below the ZAT cooling set point, the SAT cooling set point will increase by a ratio (adjustable) in order to raise the ZAT. When the ZAT equals the ZAT cooling set point, the SAT cooling set point will return to the original value. As the ZAT goes below the ZAT heating set point, the SAT heating set point will increase by a ratio (adjustable) in order to raise the ZAT. As the ZAT goes above the ZAT heating set point, the SAT heating set point will decrease by a ratio (adjustable) in order to lower the ZAT.

When the ZAT equals the ZAT heating set point, the SAT heating set point will return to the original value.

- Example: A ZAT:SAT ratio of 1:3 means for every 1°F of ZAT increase the SAT set point will decrease by 3°F; maximum -15°F (ZAT = 73°F, SAT = 69°F; ZAT = 74°F, SAT = 66°F; ZAT = 75°F, SAT = 63°F; etc.).

Heat Pump Heating Mode

Heat Pump Mode is available when the ECAT is 1°F (fixed) below the ECAT heating upper limit (60°F, adjustable) and there is a demand for heating.

Reversing Valve is "ON" in Heating Mode.

When the SAT is 2°F (adjustable) or more below the SAT heating set point (70°F, adjustable), compressor No. 2 turns on — not less than 10 minutes (adjustable) after compressor No. 1 turned on.

When the SAT is 2°F (adjustable) or more above the SAT heating set point, compressor No. 2 turns off.

When the ECAT is 1°F (adjustable) or more below the ECAT heating set point (55°F, adjustable), compressor No. 1 turns on.

When the ECAT is 1°F (adjustable) or more above the ECAT heating set point, compressor No. 1 turns off.

Heat pump operation shall be disabled if the SF-VSC modulation drops below 85% (factory suggestion; adj.).

Optional: When enabled, if there is a call for first stage heating, second stage heating will be enabled after a 10 minute (adjustable) delay. Default is "OFF".

Compressor enabling logic includes a 5-minute (fixed) minimum run-time as well as the 5 minute (fixed) minimum time off delay to prevent compressor short cycling.

Standard Lead Compressor with VFD

The compressor will modulate based on the SAT heating set point. The compressor will ramp to 100% once an hour, for 60 seconds, to push oil back to the compressor.

If there is a current call for 1st stage heating and compressor No. 1 is shut down due to an alarm (HPS1, LPS1, or Freeze Protection No. 1), compressor No. 2 will be turned on to take its place until it returns.

CAUTION

(WSHP Only) Still water freezes at 32°F. Steps must be taken by purchaser to ensure that water does not freeze in any components during winter conditions, including any loss of power or malfunction. Failure to provide freeze protection can lead to equipment and property damage.

Defrost Mode (ASHP Only)

On defrost mode, the reversing valve will switch to cooling to defrost the built-up ice on the outdoor coil.

The unit is equipped with a Defrost Timer. The defrost timer provides a selectable time interval between defrost cycles. It will allow a 10 minute defrost every 30/60/90 minutes as long as the defrost thermostat is closed. The timer is factory set at 60 minutes. The time interval may be changed to 30 or 90 minutes if desired (disconnect power to the unit before moving the jumper). The hold input on the defrost timer allows the timer to accumulate time while the compressor is running in heating mode. A warm outdoor coil causes the defrost thermostat to open which will prevent time accumulation or end the Defrost period. The defrost timer allows up to a 10 minutes defrost cycle if the defrost thermostat is closed. When the defrost period ends, either by opening of the defrost thermostat or after the 10 minutes defrost period has elapsed, the timer is reset. By shorting the two test terminals together on the defrost timer, a 60 minute delay is reduced to 14 seconds and a 10 minute delay is reduced to 2.3 seconds for testing purposes.

Auxiliary Heating Mode (If equipped)

After the heat pump has been enabled, when the SAT is 2°F (adjustable) or more below the SAT heating set point (70°F, adjustable), and after a 10-minute (adjustable) delay period, auxiliary heating will be enabled. When the SAT is above the SAT heating set point, auxiliary heating will be disabled.

On demand for auxiliary heating, the ALC controller modulates the auxiliary Gas, Electric or Hot Water heating based upon the SAT heating set point (70°F, adjustable).

Emergency Heating Mode (If equipped)

The Compressor is "OFF" in Emergency Heating Mode.

Emergency Heating mode is selectable using the Equipment Interface or Building Automation System (BAS) (default is "OFF"). Emergency Heating mode will automatically be turned on if the heat pump compressor fails or is disabled due to either the OAT going below the Compressor Disable set point of 26°F (adjustable) or the SF-VSC modulating below 85% (adjustable).

Emergency Heating Mode is available when the ECAT is 1°F (fixed) below the ECAT heating upper limit (60°F, adjustable) and there is a demand for heating.

When the ECAT is 1°F (adjustable) or more below the ECAT heating set point (55°F, adjustable), emergency heating is enabled.

When the ECAT is 1°F (adjustable) or more above the ECAT heating set point, emergency heating is disabled.

On demand for emergency heating, the ALC controller modulates the emergency Gas, Electric or Hot Water heating based upon the SAT heating set point (70°F, adjustable).

Heating Mode

Heating mode is available when the OAT is below the OAT heating upper limit (60°F, adjustable) and there is a demand to temper outdoor air to room neutral conditions. When the ECAT is 1°F (adjustable) or more below the ECAT heating set point (50°F, adjustable), heating is enabled and operates to maintain SAT heating set point (70°F, adjustable). When ECAT is

1°F (adjustable) or more above ECAT heating set point (50°F, adjustable), heating is disabled.

STAGED HEAT (ELECTRIC HEAT) 2-STAGE HEAT

Terminal W1 turning on enables first-stage heating. As SAT goes further below the SAT heating set point (70°F, adjustable), terminal W2 energizes and second-stage heating is enabled. As SAT rises, terminal W2 turns off and second-stage heating turns off. As the SAT goes 1°F (adjustable) or more above the SAT heating set point (70°F, adjustable), terminal W1 turns off and first-stage heating turns off.

STAGED HEAT (ELECTRIC HEAT) 4-STAGE HEAT

Terminal W1 turning on enables the Heating Analog Relay Module (HARM) on the control panel which activates the different stages of heating. As the SAT goes further below the SAT heating set point (70°F, adjustable), the different stages will turn on. As the SAT goes further above the SAT heating set point (70°F, adjustable), the different stages will turn off.

STAGED HEAT (GAS HEATER) 2-STAGE

Terminal W1 turning on enables first-stage heating. As SAT goes further below the SAT heating set point (70°F, adjustable), terminal W2 energizes and second-stage heating is enabled. As SAT rises, terminal W2 turns off and second-stage heating turns off. As the SAT goes 1°F (adjustable) or more above the SAT heating set point (70°F, adjustable), terminal W1 turns off and first-stage auxiliary heating turns off.

STAGED HEAT (GAS HEATER) 4-STAGE

Terminal W1 turning on enables the Heating Analog Relay Module (HARM) on the control panel which activates the different stages of heating. As the SAT goes further below the SAT heating set point (70°F, adjustable), the different stages will turn on. As the SAT goes further above the SAT heating set point (70°F, adjustable), the different stages will turn off.

Gas Heater

Terminal W1 turning on energizes the gas heat controller and first-stage auxiliary heating is enabled. If the SAT is 1°F (adjustable) or more above the SAT heating set point (70°F, adjustable) terminal W1 turns off, which deenergizes the gas heat controller, and first-stage auxiliary heating is turned off. All other stages operate as above.

MODULATED HEAT

SCR Electric Heat

On demand to temper outdoor air to room neutral conditions, the controller modulates the electric heating SCR in order to maintain the SAT heating set point (70°F, adjustable).

Modulating Gas Heater

On demand to temper outdoor air to room neutral conditions, the controller modulates the gas heat controller to control the gas flow in order to maintain the SAT heating set point (70°F, adjustable).

Modulating Hot Water Heat

On demand to temper outdoor air to room neutral conditions, the controller modulates the hot water valve to control the hot water flow in order to maintain the SAT heating set point (70°F, adjustable).

UNOCCUPIED MODE

When the Occupancy Control indicates the end of the Occupied mode, the compressor(s) and outdoor fan(s) will turn off (subject to minimum run-time) or the heating system will turn off. The SF and EF will continue to run for 2 minutes before turning off. After this, the ECW will turn off and the OA damper will close. The unit is now off.

Safety Switches

- **High Pressure Switch (HPS1):** If HPS1 is open, compressor No. 1 will turn off and the controller will issue an alarm. After manually resetting HPS1, the HPS1 alarm will reset. Following a minimum time off delay, compressor No. 1 will turn on. If the controller records 3 high pressure start/restart failure incidents within 1 hour, compressor No. 1 is locked out and the controller will issue an alarm. The compressor lockout can be reset in the Equipment Touch display pad or by cycling the power of the controller. This sequence is the same for compressor no. 2, Y2, and HPS2.
- **Low Pressure Switch (LPS1):** If LPS1 is open after the LPS1 bypass time, the controller will issue an alarm and compressor No. 1 turns off. After 30 seconds (fixed), the LPS1 alarm will reset. Following a minimum time off delay, compressor No. 1 will turn on. If the controller records 3 low pressure start/restart failure incidents within 1 hour, compressor No. 1 is locked out and the controller will issue an alarm. The compressor lockout can be reset in the Equipment Touch display pad or by cycling the power of the controller. This sequence is the same for compressor no. 2, Y2, and LPS2.
- **Condensate Overflow Switch:** When the condensate overflow switch (COFS) detects an overflow condition at the drain pan, the contact closes at the unit controller and the unit will disable the cooling system and issue an alarm.

SAFETY SHUTDOWN

Smoke Detector: When a smoke detector (SD) is provided, it is wired directly to the controller. If smoke is detected, the controller will shut down the unit. Other instances where shutdown will occur are as follows: if a compressor fails to start 3 times in an hour due to high/low pressure switch or DX leaving air temperature lock out, or if the controller detects an SAT sensor failure.

Energy Management Relay: The energy management relay (EMR) can be configured to force unoccupied mode or to force an emergency shutdown. When the EMR contact is open, the EMR signal is triggered and the unit will shutdown or go into unoccupied mode (depending on the configuration).

REFRIGERANT CHARGING

The 62H Series units come from the factory with the appropriate operating charge of R-454B.

Charge adjustment might be necessary if subcooling temperatures are too high due to excess refrigerant in the system that is subsequently backed up in the condenser. This symptom could also indicate a failed TXV or line restriction. If there is no line restriction and the TXV is working correctly, reclaim enough R-454B refrigerant so the system ambient compensated pressure readings are at the desired levels. Use a refrigerant recovery unit to safely remove the refrigerant, because it is illegal to release R-454B refrigerant into the atmosphere. After the addition or removal of refrigerant, the unit must be allowed to stabilize for at least 10 minutes before reaching any conclusions if any other adjustments need to be made.

All 62H Series units are equipped with hot gas reheat or liquid subcooling reheat. Operation of the reheat system must be disabled prior to charging unit. To disable, use the unit control interface to disable reheat operation, or disconnect the power or control signal to the reheat valve or solenoid assembly.

The type of unit and operation determines the ranges for liquid subcooling and evaporator superheat. The system is overcharged if the subcooling temperature is too high and the evaporator is fully loaded. High superheat results in increased subcooling. The system is defined as undercharged if the superheat is too high and the subcooling is too low.

To correct an undercharged system, add refrigerant to reduce the superheat and raise subcooling. If the subcooling is correct and the superheat is too high, the TXV may need adjustment to correct the superheat. When checking the charge, units with hot gas reheat must be checked with the hot gas reheat valves closed and the system in cooling mode. To confirm proper charge, the unit should be left in reheat mode to check for proper operation. See Tables 13 and 14 for proper charge levels.

Table 13 – Superheat and Subcooling - 100% OA^{a,b,c}

AMBIENT AIR TEMP.	95°F	85°F	75°F	65°F	55°F	45°F
Subcooling	8°F - 10°F				In heating mode.	
Superheat	10°F - 13°F				In heating mode.	

NOTE(S):

- Subcooling readings must be taken with the reheat circuit disabled and in the cooling mode. On water-source units, water regulating valves need to be open 100%.
- Circuit #1 Subcooling and Superheat readings must be taken with circuit #2 disabled/not running.
- Circuit #2 Subcooling and Superheat readings must be taken with circuit #1 energized/running.

Table 14 – Superheat and Subcooling - Heat Pump^a

AMBIENT AIR TEMP.	95°F	85°F	75°F	65°F	55°F	45°F
Subcooling	8°F - 12°F		8°F - 10°F		In heating mode.	
Superheat	6°F - 15°F				In heating mode.	

NOTE(S):

- Subcooling and Superheat readings must be taken with the reheat circuit disabled and in the cooling mode.

Step 15 – Unit Start-Up

Complete unit start-up. Refer to the unit Controls, Operation, and Start-up manual for start-up check lists and start-up instructions.

Step 16 – Test Mode and Fan Balancing

Carrier recommends all 62H Series units undergo proper air balancing to verify unit supply and exhaust airflow. Consult the Controls, Operation, and Start-up manual.

Typical Wiring Diagrams

See Fig. 16 for typical wiring diagrams. See Fig. 17 and 18 for factory mounted convenience outlet diagrams.

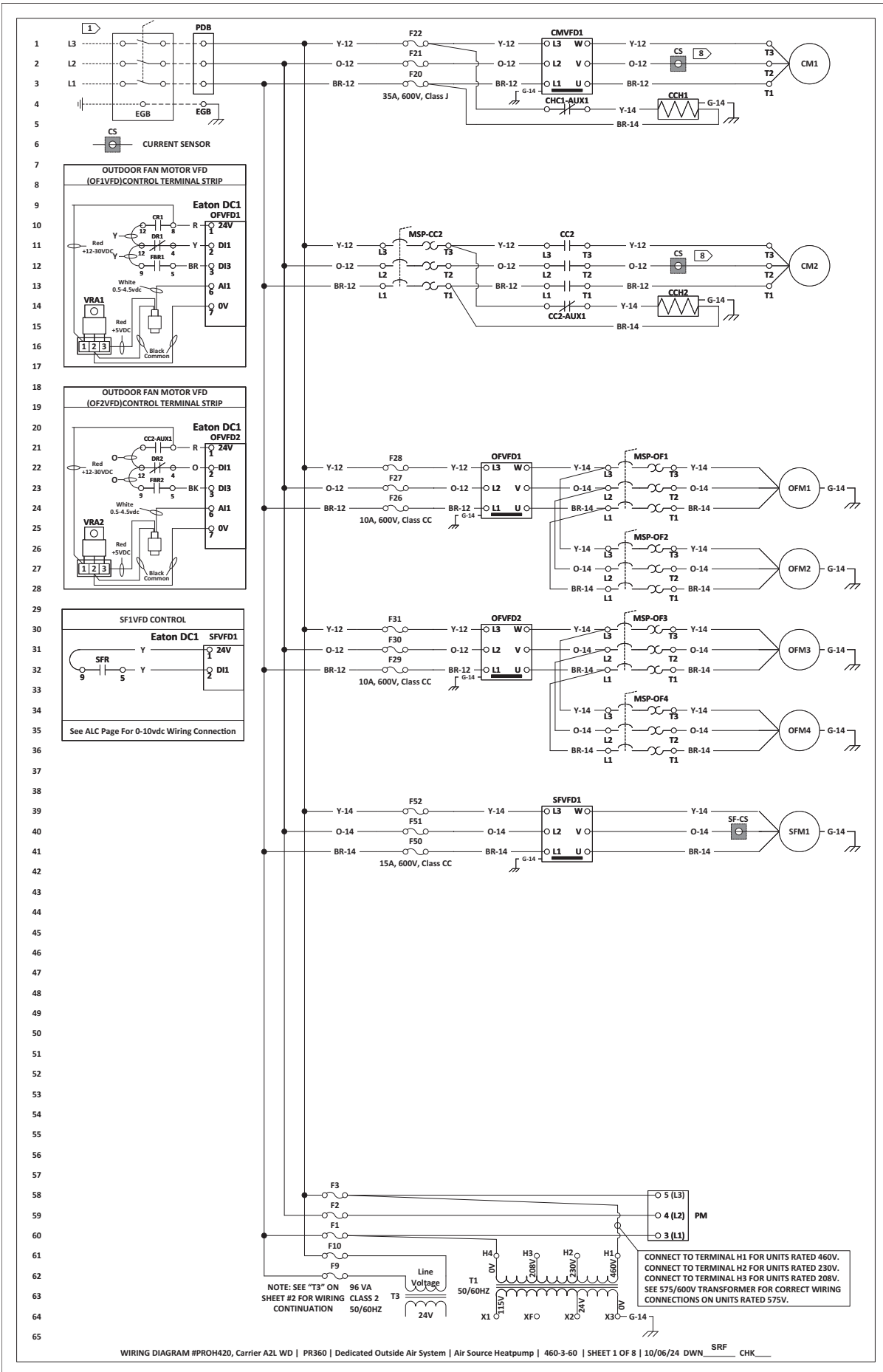

Fig. 16 — Typical Wiring Diagram

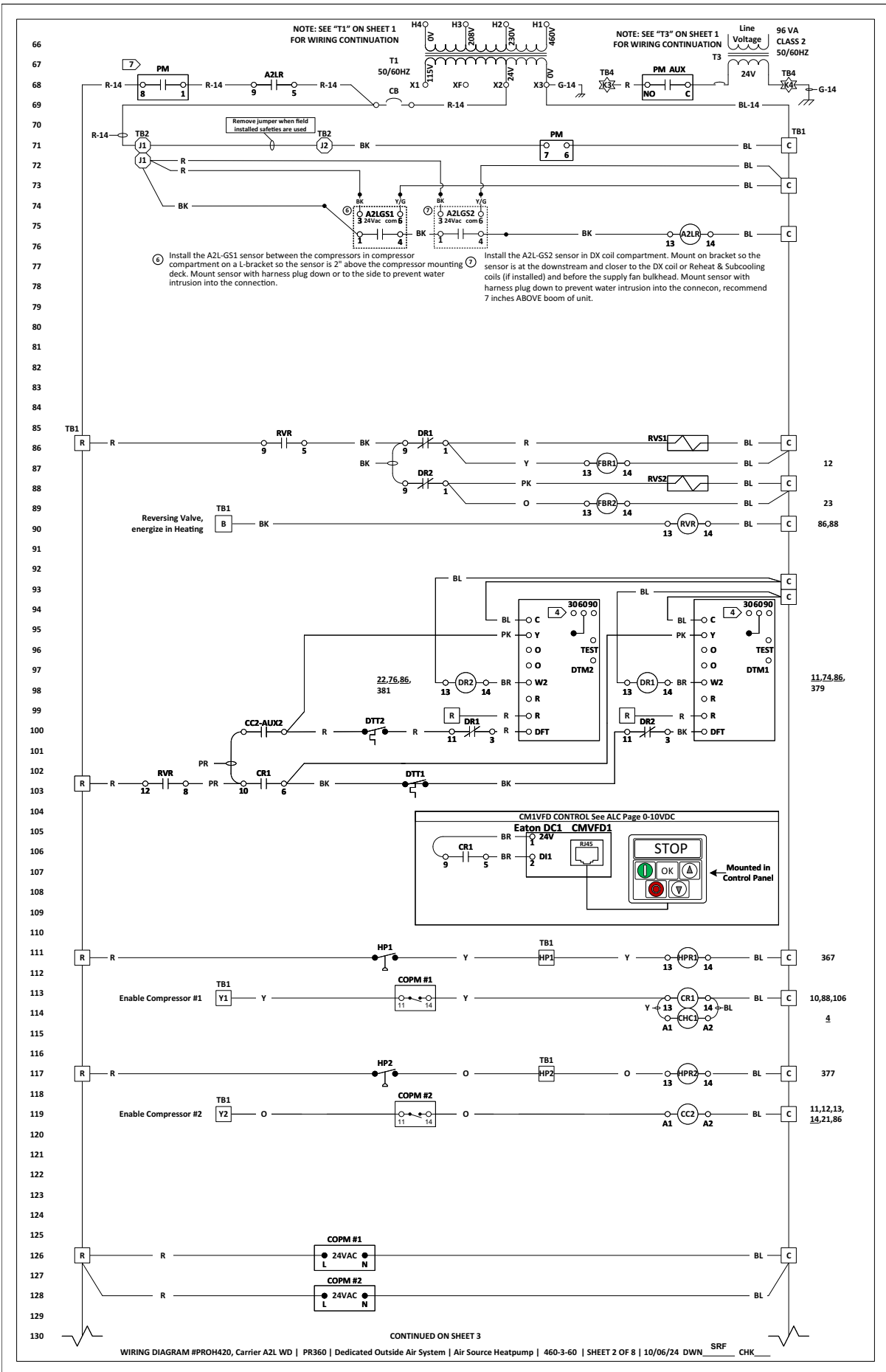

Fig. 16 – Typical Wiring Diagram (cont)

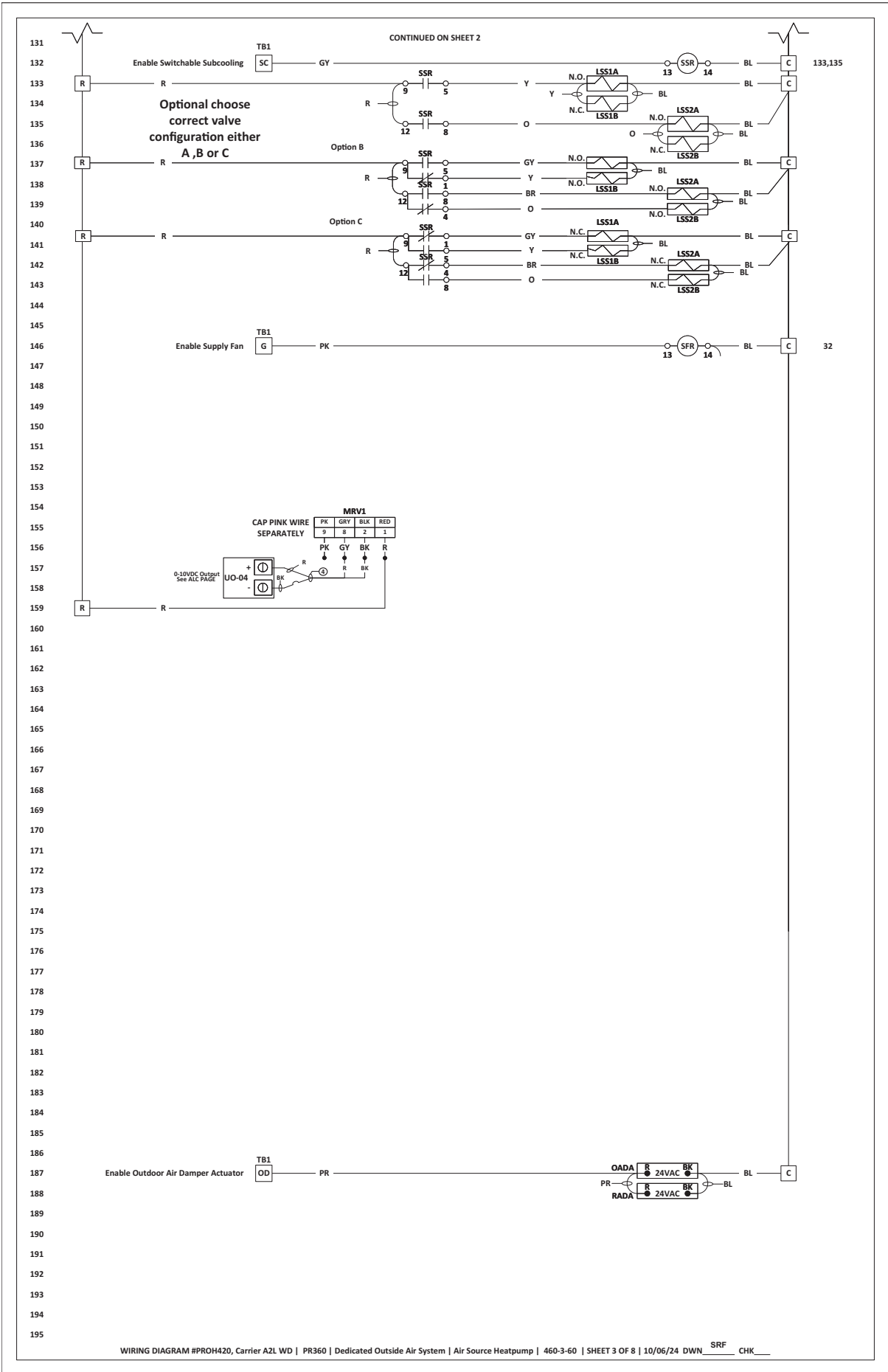

Fig. 16 — Typical Wiring Diagram (cont)

196
197
198
199
200
201
202
203
204
205
206
207
208
209
210
211
212
213
214
215
216
217
218
219
220
221
222
223
224
225
226
227
228
229
230
231
232
233
234
235
236
237
238
239
240
241
242
243
244
245
246
247
248
249
250
251
252
253
254
255
256
257
258
259
260

WIRING DIAGRAM FOR THE GAS FURNACE (HEAT PUMP) P

Calibration and Setup
 - Set the INPUT RANGE jumper to the correct position for the signal to be used (0-15 V).
 - Set the deadband jumper to the desired value (3%). This can be changed at any time with the power on.
 - Connect the power supply and the input signal to the correct terminals.
 - Turn on the power and the POWER LED will light.
 - Apply an input signal equal to the R1 setpoint (0.5V).
 - Adjust the R1 pot clockwise until the RELAY1 LED goes out, then slowly adjust the R1 pot counterclockwise until the LED just lights.
 - Test the operation by increasing the input signal and watch as R1 turn on at the selected setpoints. Then decrease the signal and watch as the relays turn off at the selected setpoints minus the deadband.

Auxiliary Heat is "ON" in Defrost Mode.

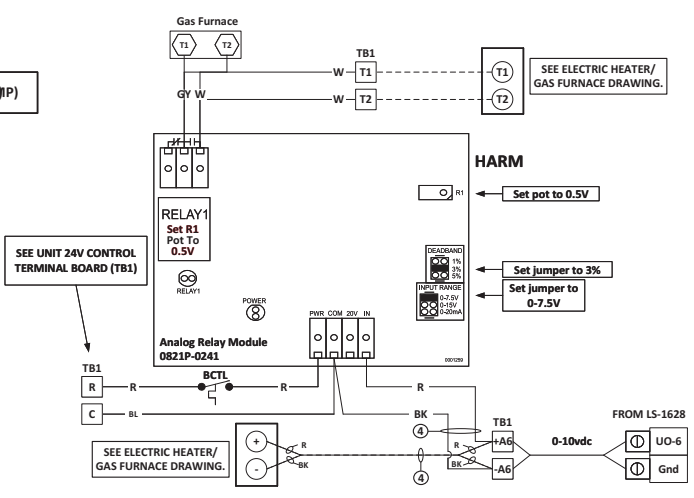

Fig. 16 – Typical Wiring Diagram (cont)

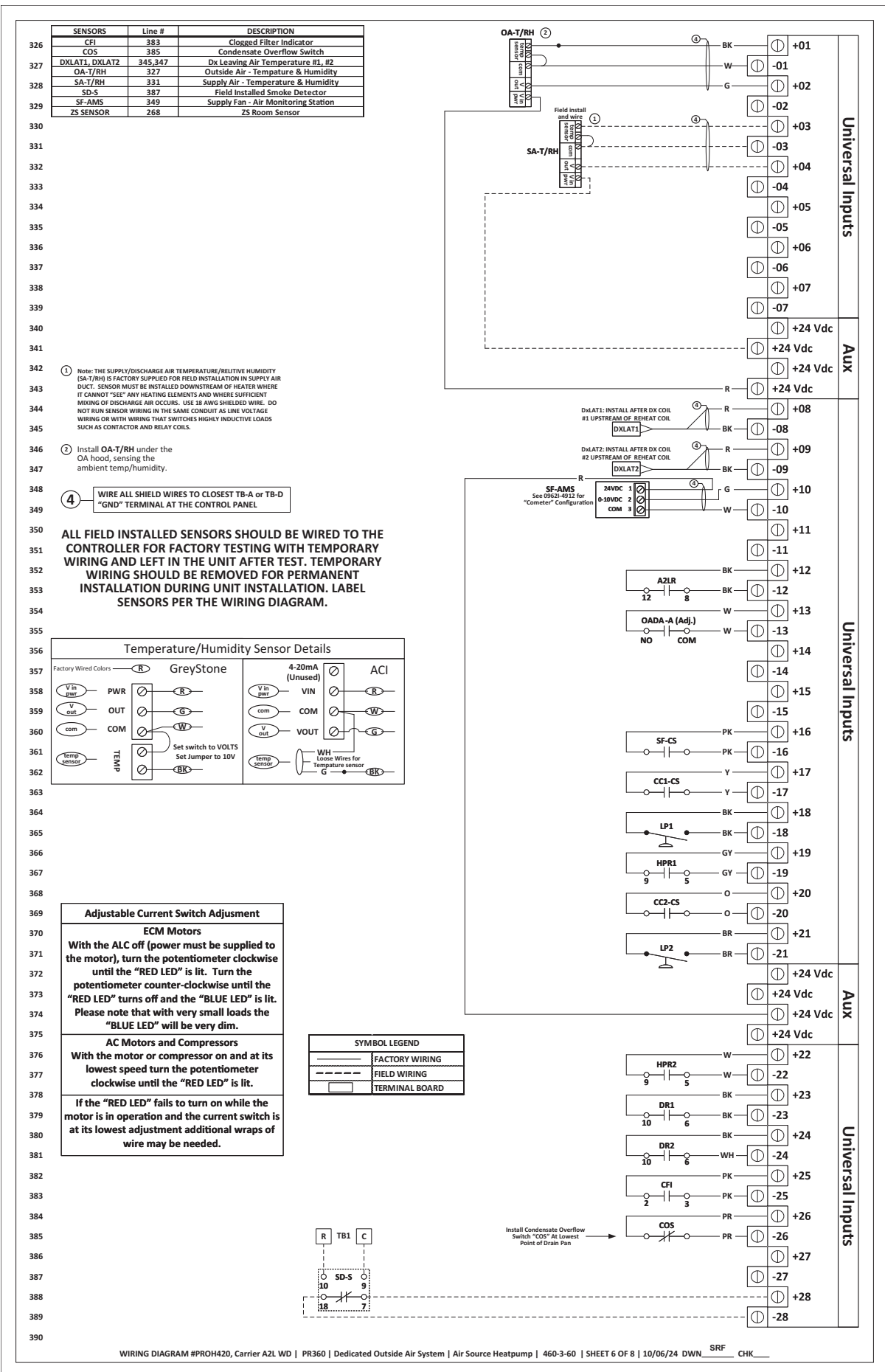

Fig. 16 – Typical Wiring Diagram (cont)

LEGEND - ITEMS INSIDE CONTROL PANEL			
ITEM	FUNCTIONAL DESIGNATION	LINE NUMBER	DESCRIPTION
101	AZLR	75	AZL Sensor Relay
102	CC1-CS	363	Compressor #1 - Current Switch
103	CC2	119	Compressor Contactor no. 2
104	CC2-AUX1, CC2-AUX2	#	CC2 - Auxiliary Contacts no. 1 and 2
105	CC2-CS	369	Compressor #2 - Current Switch
106	CHC1	114	Crankcase Heater Contactor #1
107	CHC1-AUX1	#	CHC1 - Auxiliary Contact no. 1
108	CMVFD1	1,105,292	Compressor #1 VFD
109	CR1	113	AZL RELAY#1
110	DR1, DR2	83, 83	Defrost Relay #1, #2
111	DTM1, DTM2	83,83	Defrost Timer #1, #2
112	EGB	4	Equipment Grounding Bar
113	FBR1, FBR2	87, 89	Fan Bypass Relay #1, #2
114	HARM	247	Heat Analog Relay Module
115	HPR1, HPR2	111, 117	High Pressure Relay #1, #2
116	MSP-CC2	11	Motor Starter Protection - CC2
117	MSP-OF1	22	Motor Starter Protection- Outdoor Fan no. 1
118	MSP-OF2	26	Motor Starter Protection- Outdoor Fan no. 2
119	MSP-OF3	30	Motor Starter Protection- Outdoor Fan no. 3
120	MSP-OF4	34	Motor Starter Protection- Outdoor Fan no. 4
121	OFVFD1, OFVFD2	10,22,21,30	Outdoor Fan VFD #1, #2
122	PDB	1,456	Power Distribution Block
123	PM	59,68,68,71	Power/Phase Monitor
124	RVR	90	Reversing Valve Relay
125	SF-CS	361	Supply Fan - Current Switch
126	SFR	146	Supply Fan Motor Relay
127	SFVFD1	31,39,280	Supply Fan - Variable Frequency Drive #1
128	SSR	132	Switchable Subcooling relay
129	VR#1, VR#2	15,26	Voltage Regulator Assembly #1, #2

SEE LINE NUMBER TO THE RIGHT OF CONTACTOR COIL ON WIRING DIAGRAM.

LEGEND - ITEMS OUTSIDE CONTROL PANEL			
ITEM	FUNCTIONAL DESIGNATION	LINE NUMBER	DESCRIPTION
101	AZLGS1	75	AZL GAS SENSOR #1
102	AZLGS2	75	AZL GAS SENSOR #2
103	BCTL	256	Blower Compartment Thermal Limit
104	CCH1	4	Crankcase Heater #1
105	CCH2	14	Crank Case Heater #2
106	CM1	2	Compressor Motor No.1
107	CM2	12	Compressor Motor No.2
108	COPM #1	113,126	Compressor Overload Protection Module #1
109	COPM #2	119,128	Compressor Overload Protection Module #2
110	DTT1, DTT2	87,85	Defrost Tstat #1, #2
111	HP1	111	High Pressure Switch #1
112	HP2	117	High Pressure Switch #2
113	LP1	365	Low Pressure Switch #1
114	LP2	371	Low Pressure Switch #2
115	LSS1A, LSS1B	133,134	Liquid Sub-Cooling Solenoid no. 1A, 1B
116	LSS2A, LSS2B	135,136	Liquid Sub-Cooling Solenoid no. 2A, 2B
117	MRV1	155	Modulating Reheat Valve #1
118	OADA	187,355	Outside Air Damper Actuator
119	OFM1	23	Outdoor Fan Motor #1
120	OFM2	27	Outdoor Fan Motor #2
121	OFM3	31	Outdoor Fan Motor #3
122	OFM4	35	Outdoor Fan Motor #4
123	RADA	188	Return Air Damper Actuator
124	RVS1, RVS2	86,88	Reversing Valve #1, #2
125	SFM1	40	Supply Fan Motor #1

SYMBOL LEGEND			
	FACTORY WIRING		NORMALLY OPEN CONTACTS
	FIELD WIRING		NORMALLY CLOSED CONTACTS
	EARTH GROUND		IDENTIFIABLE TERMINAL
	CHASSIS (PANEL) GROUND		NON-IDENTIFIABLE TERMINAL, OTHER WIRE JUNCTIONS, INCLUDING SCHEMATIC
	COIL		

WIRE COLOR LEGEND	
ABBREVIATION	COLOR
BK	BLACK
BL	BLUE
BR	BROWN
G	GREEN
O	ORANGE
PK	PINK
PR	PURPLE
R	RED
W	WHITE
Y	YELLOW

NOTE: NUMBER PLACED AFTER DASH FOLLOWING COLOR CODE INDICATES WIRE GAUGE. EX. - BK-12 IS A BLACK, 12 AWG WIRE.
NO NUMBER AFTER COLOR CODE INDICATES 18 AWG WIRE. EX. - BK IS A BLACK 18 AWG WIRE.

FUSE TABLE						
FUSE NO.	CLASS	VAC	AMPS-208/230V	AMPS-460V	XFMR	TIME DELAY
F1, F3	CC	600	3	2	350VA	YES
	CC	600	2	1.5	250VA	YES
	CC	600	2	1.5	200VA	YES
F2, F9, F10	CC	600	1.5	3/4	150VA	YES
	CC	600	1	1	N/A	YES
CB	CC	600	16	16	350VA	YES
	CC	600	10	10	250VA	YES
	CC	600	10	10	200VA	YES
	CC	600	6	6	150VA	YES

- 1 FIELD POWER SUPPLY 208/230/460/575-3-60. MINIMUM CIRCUIT AMPACITY AND MAXIMUM SIZE AND TYPE OF BRANCH-CIRCUIT SHORT-CIRCUIT AND GROUND-FAULT PROTECTION PER UNIT RATING PLATE. PROVIDE DISCONNECTING MEANS AS REQUIRED.
- 2 TYPICAL MOTORS AND COMPRESSORS SHOWN. SEE CONNECTION DIAGRAM ON MOTOR OR COMPRESSOR FOR ACTUAL WIRING DETAIL.

5 SET TIME DELAY PERIOD TO 5-MINUTES. UPON INITIAL APPLICATION OF POWER TO "TD", CONTACTOR "CC" IS ENERGIZES AFTER A 5-MINUTE START DELAY. WHEN POWER IS REMOVED, A LOCKOUT CONDITION AND 5-MINUTE TIME DELAY PERIOD (ADJUSTABLE) IS INITIATED. DURING THIS PERIOD, CONTACTOR "CC" CANNOT BE ENERGIZED.

8 WRAP WIRE THREE TIMES THRU CURRENT SENSOR IF WIRE IS 14 GAUGE. WRAP WIRE TWO TIMES THRU CURRENT SENSRO IF WIRE IS 12 GAUGE.

Fig. 16 – Typical Wiring Diagram (cont)

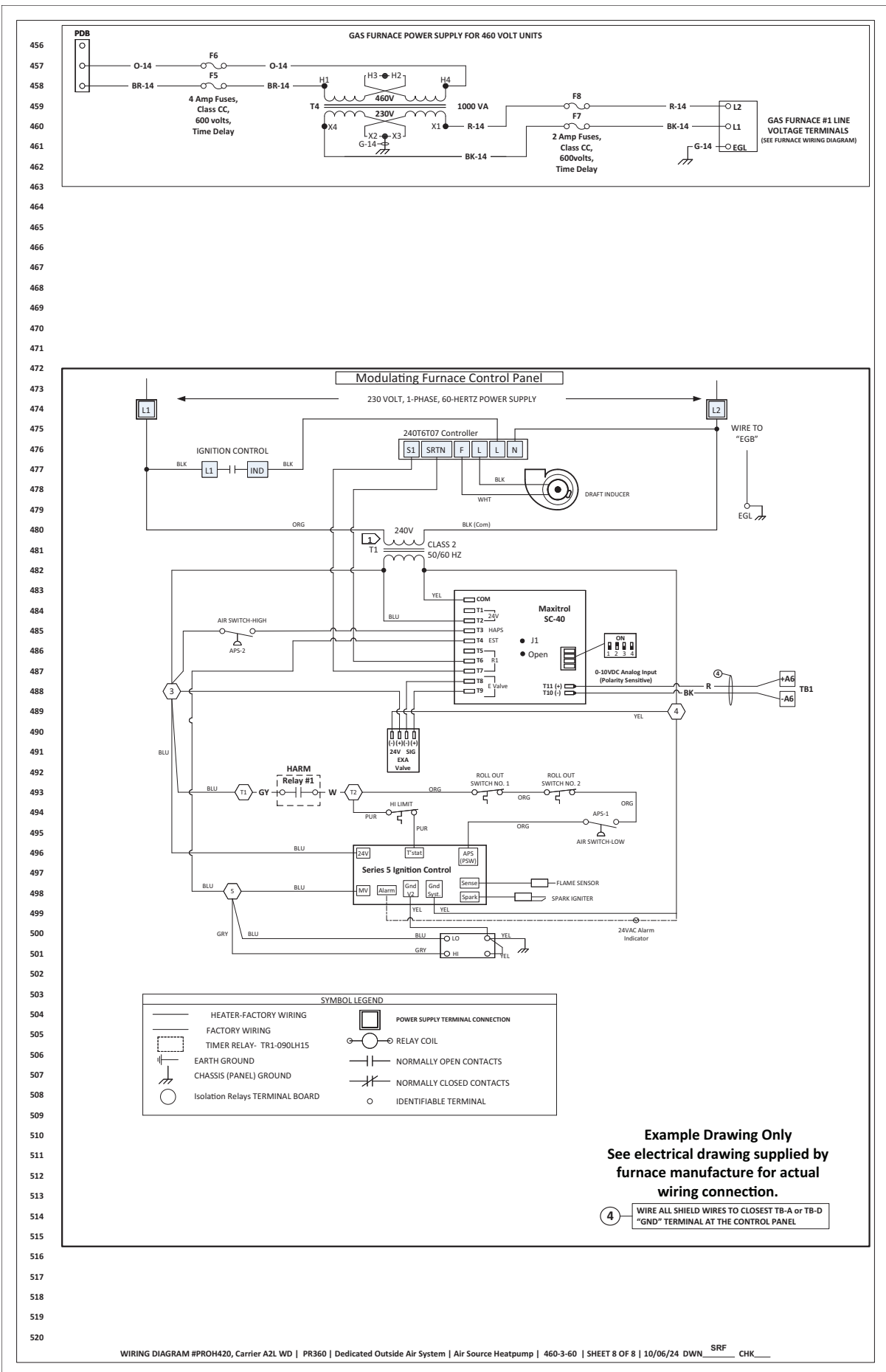

Fig. 16 – Typical Wiring Diagram (cont)

WIRING FOR 208V FACTORY MOUNTED CONVENIENCE OUTLET

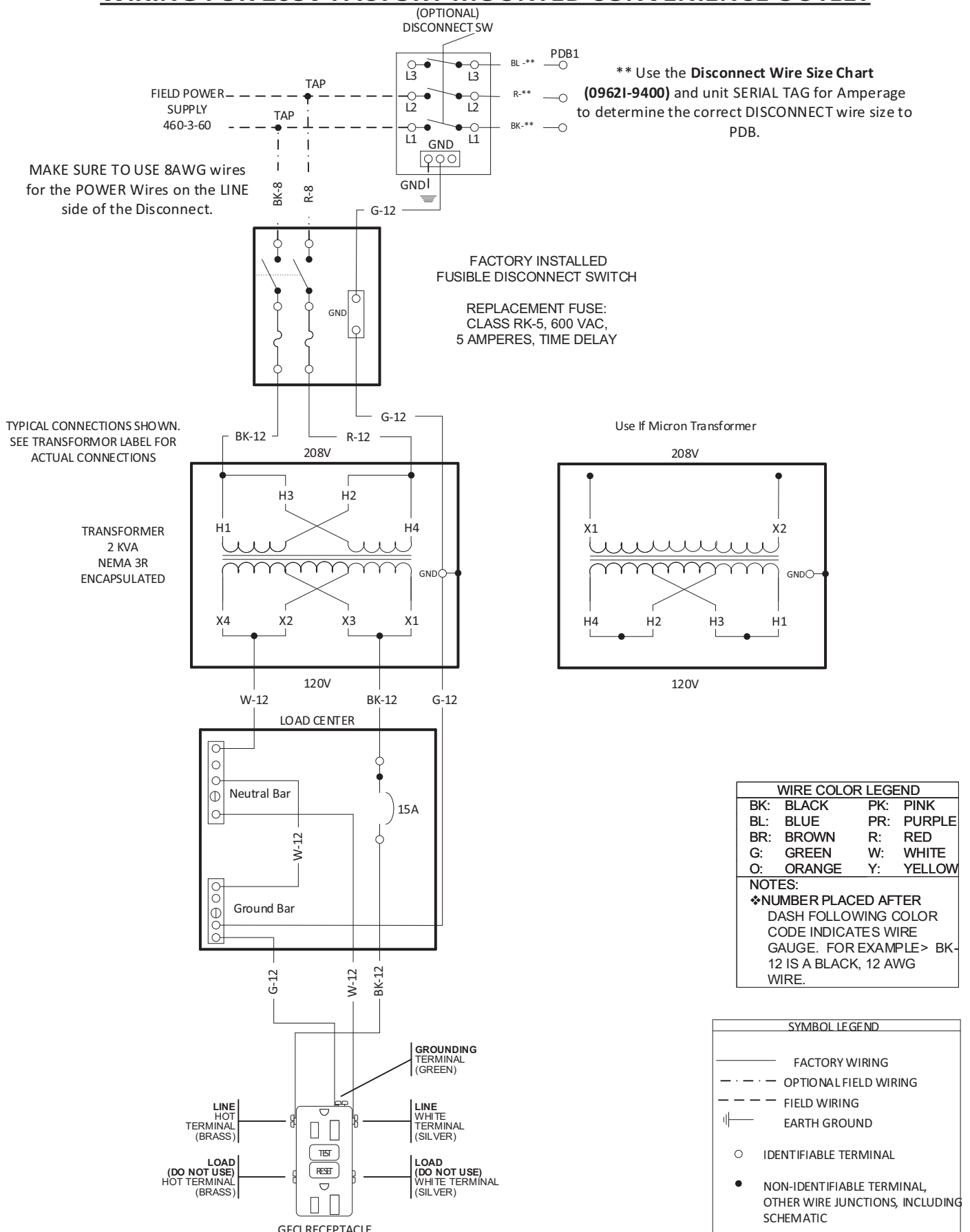
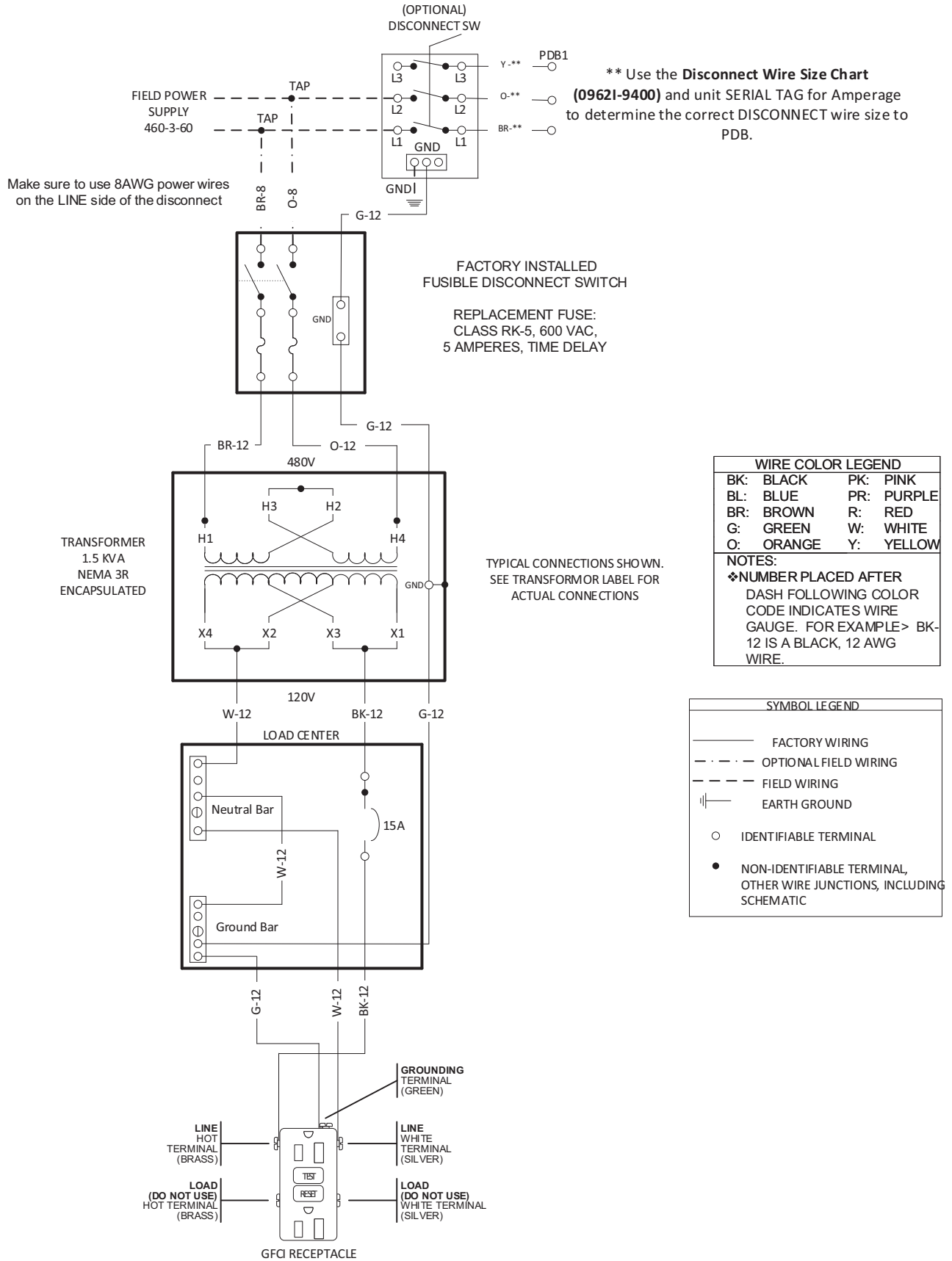

Fig. 17 — Wiring Diagram for 208V Factory Mounted Convenience Outlet

WIRING FOR 480V FACTORY MOUNTED CONVENIENCE OUTLET



WIRING DIAGRAM #09621-3582A REV B | 115V Convenience Outlet Wiring | 460-3-60 | SHEET 1 OF 1 | 07/01/21 DWN_SRE_CHK_LWE

Fig. 18 — Wiring Diagram for 480V Factory Mounted Convenience Outlet

MAINTENANCE

Prior to any maintenance or service to the unit, shut off, lockout, and tagout the electrical disconnect and fuel valve (if applicable) that supplies the unit in accordance with OSHA regulations and, if the unit includes electric or gas heat, allow ample time for the unit to cool. After maintenance is performed or the unit is serviced, the unit shall be re-commissioned per the start-up procedure.

Installation Code and Quarterly Inspections

All installation and service of Carrier's 62H equipment must be performed by a contractor qualified in the installation and service of equipment sold and supplied by Carrier, as well as conform to all requirements set forth in the manuals and all applicable governmental authorities pertaining to the installation, service, operation, and labeling of the equipment.

To help facilitate optimum performance and safety, Carrier recommends that a qualified contractor conducts, at a minimum, quarterly inspections of your 62H Series equipment and perform service where necessary, using only replacements parts sold and supplied by Carrier.

General

QUARTERLY

Follow the entire start-up procedure at this time and check settings (controls, operating temperatures, operating pressures, power, and control voltages) and operation.

Unit Exterior

CABINET EXTERIOR

After installation, fix scratches. Periodic painting should be done thereafter, as required. The caulk should be inspected annually. Re-apply caulk as needed to maintain integrity. For units with harsh coating protection, contact your Carrier sales office to purchase a touch up coating kit.

UNIT LOCATION

Verify that no flammable objects, liquids, or vapors are present near the unit. If unit includes gas heat, clearances to combustibles around the vent must be adhered to. Refer to "Service Clearances" on page 10 for clearance requirements. Do not hang anything from or place anything on the unit. Keep the area around the unit free of all objects.

Direct Drive Supply and Exhaust Fans

BLOWER WHEEL

Inspect blower wheel and clean as necessary. A small build-up of dust can cause a significant decrease in blower performance. Check for excessive vibration. Clean and repair as required.

MOTORS

Inspection

Inspect motor every 3 months. Keep the motor clean and vent openings clear.

Lubrication

1. Motors with grease fittings must be lubricated as indicated in Table 15.

Table 15 — Motor Lubrication Intervals^a

NEMA FRAME SIZE (MOTOR HP)	RATED AT 1800 RPM (HRS)
up to 210 (3-5)	6,000
210-280 (7.5-20)	4,750
280-360 (25-30)	3,700

NOTE(S):

- a. These intervals are based on severe duty. Over lubricating bearings could result in reduced motor life.

2. A high grade ball or roller bearing grease must be used. Recommended grease for standard service is Mobil PolyrexTM EM. Other compatible greases include ChevronTexaco Polystar^{®1}, ChevronTexaco Rykon^{®1} Premium 2, Pennzoil^{®1} Pen 2 Lube, and ChevronTexaco SRI.
3. Motors without grease fittings are sealed for life and do not require re-lubrication.

Lubricating Instructions

Before greasing, be sure fittings are clean and free from dirt. Remove grease relief plug or plate and, using a low-pressure grease gun, pump in the required grease. Do not over-grease. Re-lubrication intervals are specified in Table 15. After re-lubricating, allow motor to run for 10 minutes before replacing relief hardware.

IMPORTANT: In general, it is not recommended to mix greases of different brands. The mixing of different types of thickeners may destroy the composition and physical properties of the grease. In the event that a different grease is required by the end user, the following steps can be taken. Using the Lubricating Instructions, open grease outlet and purge the system as much as possible of the old or unwanted grease. Repeat this same operation after one week of service.

Condensing Fans

Manually rotate to ensure free movement. Check that all fan mounting hardware is tight. Check motor bearings for wear.

Refrigeration Circuit Components

INDOOR COIL

Check for dirt and bent fins. Clean with water from blower side towards filter side.

OUTDOOR COIL

Check for dirt and bent fins. Clean by brushing off with broom.

COMPRESSORS

Compressors are factory-supplied with a charge of oil and should not require additional maintenance.

Condensate Drain Pan and Drain

Check for blockages. Clean as necessary with a mixture of 1/2 cup (0.1 L) bleach and 1 gallon (1.9 L) of warm water, if signs of mold or algae are present.

Dampers

DAMPERS

Check and clean blades.

DAMPER MOTOR/LINKAGES

Verify that all damper linkages move freely. Lubricate if necessary.

1. Third-party trademarks and logos are the property of their respective owners.

Energy Conservation Wheel

OVERVIEW

NOTE: The information in this section applies to all available models of the energy recovery wheels.

Energy recovery wheels rotate between the incoming outdoor air stream and the building exhaust air stream. As the wheel rotates, it transfers a percentage of the heat and moisture differential from one air stream to the other.

Instead of wasting energy in the exhaust airstream, it is temporarily captured by the energy transfer media and then released to pre-heat, pre-cool, humidify, or dehumidify the incoming air. See Fig. 19 for example of ERV system with recovered energy.

Carrier uses wheels that are designed with segmented energy transfer media. The segments are mounted in a stainless steel wheel, which then rotates within a galvanized metal cassette frame. The segmentation allows the transfer media to be easily removed for cleaning or replacement.

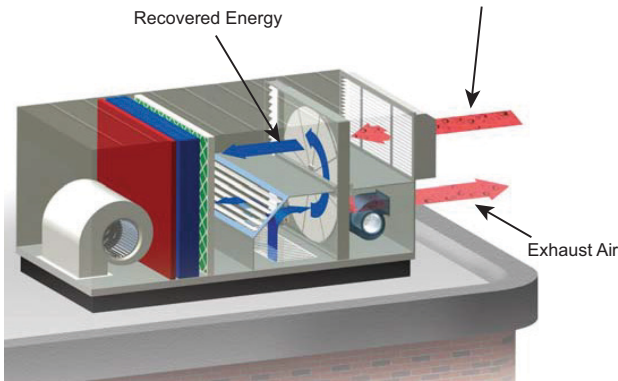

NOTE: The RA damper is only included with units ordered with the factory-installed night setback special order option.

Fig. 19 — ERV System Pre-conditioned Outdoor Air with Recovered Energy

MOISTURE TRANSFER

Carrier utilizes synthetic polymer wheels with permanently bonded silica gel desiccant material. Desiccants transfer water molecules between two air streams of different vapor pressures. The vapor pressure differential drives water molecules into/from desiccants to transfer moisture from the more humid air stream to the drier air stream as the wheel rotates. See Fig. 20 for wheel and frame assembly example.



Fig. 20 — Structural Metal Wheel and Frame Assembly with Removable Polymer Segments

WHEEL COMPONENTS

Use Items 1-8 and Fig. 21 for components in the energy recovery wheel.

1. Removable Segment (Also referred to as “Media”)
2. Permanent Tension Belt
3. Pulley
4. Embedded Segment Stiffeners
5. Segment Retaining Latches
6. Bearing Beam and Bearing Access Cover Plate (Diameter Seals are behind Bearing Beam on both sides)
7. Adjustable Purge
8. Motor

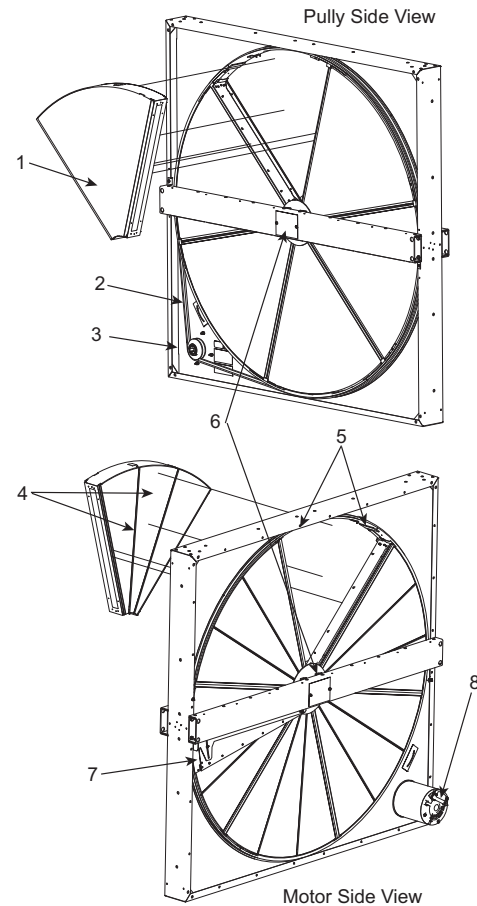

Fig. 21 — Energy Recovery Wheel (Exploded View)

CASSETTE SERIAL NUMBER IDENTIFICATION

All energy recovery wheels are labeled with model, serial, and part numbers. The label can be found on the sheet metal adjacent to the drive pulley. You should always have a serial number when contacting Carrier for product support or when ordering replacement parts. See Fig. 22 for product label location example (on pulley corner of each wheel).

See “Energy Recovery Wheel Product Information” on page 54 to log the details for energy recovery wheel in the DOAS System.



Fig. 22 — Product Label With Serial Number Location
PRE-START-UP

⚠ WARNING

Before servicing entire HVAC system, turn off the main disconnect to the unit. Use the site-specific lockout-tagout procedure.

Motor Guidelines

Follow Steps 1-4 for proper motor function.

1. Always follow motor manufacturer’s wiring instructions.
2. All wheels should rotate clockwise when viewed from the pulley side.
3. On 3-phase motors, if the wheel does not rotate clockwise (when viewed from pulley side), shut off power to the system and interchange any two power supply leads to reverse rotation.
4. Inverter duty motors should not exceed a 20:1 turn down ratio.

Inspect Diameter Seals

Diameter seals are set at the factory, but should be inspected before operation. See Fig. 23 for seal diameter example.

To check the seal, slide a piece of paper (“feeler gauge”) between the seal and the media at multiple locations on both sides of the bearing as you rotate the wheel slowly by hand (clockwise when viewed from the pulley side). Verify that the media slightly grabs the paper during the rotation.

If necessary, loosen adjusting screws along the bearing beam and reset seal to a slight interference fit with the wheel media. See Fig. 23 for adjusting screws.

SET PURGE ANGLE (IF NECESSARY)

The purge angle is factory set to 5-degrees. If the HVAC system design specification requires a different angle, complete Steps 1-4 to adjust the purge.

1. Loosen the three purge adjusting screws (Fig. 24).
2. Adjust purge sector to the specified angle (Fig. 25).
3. Tighten the purge adjusting screws.
4. Turn the wheel by hand clockwise (when viewed from pulley side) to check for interference.

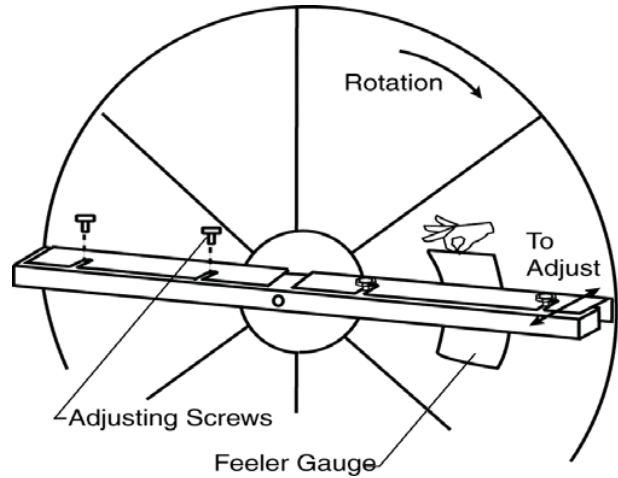

Fig. 23 — Diameter Seal Setting Example

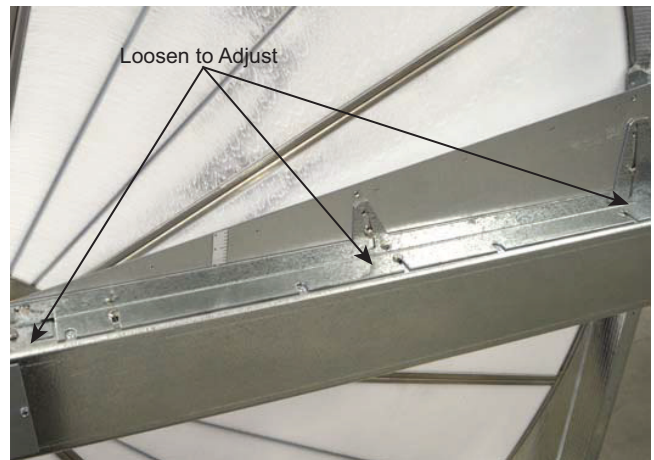

Fig. 24 — Purge Installed On Motor Side Of Wheel

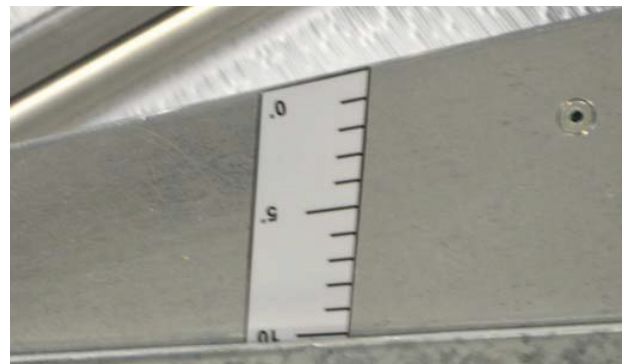

Fig. 25 — Set Purge Angle

Check Purge Seal

Check for a slight interference fit between the seal and the face of the wheel by sliding a piece of paper “feeler gauge” between the seal and the media at multiple locations along the purge seal as you rotate the wheel slowly by hand (clockwise when viewed from the pulley side). Verify that the media slightly grabs the paper during the rotation as shown in Fig. 26.

If it is necessary to adjust a purge seal to the face of the wheel, loosen the two or three screws (depending on the wheel size) along the bearing beam as shown in Fig. 26. Adjust to the proper distance from the media surface. Tighten the screws and retest the seal.



Loosen to Adjust

Fig. 26 — Purge Seal Check/Adjust Example

Inspection

⚠ WARNING

Before servicing entire HVAC system, turn off the main disconnect to the unit. Use the site-specific lockout-tagout procedure.

Before starting the system, confirm Items 1-7.

1. Wheel spins freely by hand in a clockwise direction, with no interference noise.
2. Wheel is not “racked” (wheel rotates parallel to bearing beams).
3. Belt tracks near middle of rim (not against rim support).
4. Belt is not flipped on stretch belts for 36 in. wheels and above. The narrow face contacts the wheel rim on a continuous link belt. Small tabs contact wheel rim.
5. All media segments are installed in the wheel and latches are closed. See “Segment removal/installation” on page 51 for instructions.

6. Diameter seals are properly set and secured. Seal is parallel to and just touching media surface. Refer to “Inspect Diameter Seals” on page 48.
7. If purge is specified, it is set at proper angle. Refer to “SET PURGE ANGLE (IF NECESSARY)” on page 48 for instructions.

POST-START-UP

Inspection

After applying power to system, confirm Items 1-6.

1. Verify that the wheel is rotating clockwise (when viewed from the pulley side).
2. On 3-phase motors, if the wheel does not rotate clockwise (when viewed from pulley side), shut off the power to the system and interchange any two power supply leads to reverse rotation.
3. Visually inspect belt; ensure belt is tracking near the center of the rim.
4. Verify that wheel speed is approximately 45-50 rpm (rotating clockwise when viewed from pulley side).
5. No excessive noise (scraping, brushing, banging etc.).
6. Running amps do not exceed nameplate Full Load Amps (FLA).

Item Check

NOTE: Before beginning normal operation check/verify Items 1-3.

1. The area around the energy recovery wheel is free of debris.
2. Cabinet doors are closed and secure.
3. Power is restored to unit.

INSPECTION CHECKLIST

⚠ WARNING

Before servicing entire HVAC system, turn off the main disconnect to the unit. Use the site-specific lockout-tagout procedure.

Carrier recommends inspecting the wheel once per year to verify that the wheel, motor, belt, energy transfer segments, and seals are all in good working order. Routine maintenance is not required other than to clean the energy transfer media periodically on a schedule that is determined by the application. See “Cleaning Energy Recovery Wheel Segments” on page 50 for details. See Table 16 for recommended inspection steps for energy recovery wheels.

Table 16 — Energy Recovery Inspection List^a

CONDITIONS TO VERIFY DURING INSPECTION	CHECK OFF WHEN VERIFIED
There is no damage to the segments.	
Energy transfer media is not excessively dirty or covered with tacky substances (check both sides).	
Belt is installed around the wheel and pulley.	
Belt is positioned and tracking properly with the narrow face of the urethane belt OR the small tabs on a continuous link belt centered on wheel rim during rotation.	
Belt is not flipped or twisted.	
Belt is not excessively worn (rounded edges, cuts, breaking, etc.).	
Wheel spins freely by hand clockwise (when viewed from pulley side).	
Motor is running at or below the FLA specified by the motor manufacturer. Check nameplate on motor for specifications.	
When motor is running, wheel turns clockwise when viewed from pulley side.	
Diameter seals are properly set and secured with the seal just touching media surface.	
Media segments are properly installed in wheel, sitting flat in wheel.	
All segment retaining latches are closed and secured.	

NOTE(S):

- a. Perform an inspection of the wheel while it is running and again when it is turned OFF.

CLEANING ENERGY RECOVERY WHEEL SEGMENTS

All energy recovery wheels with 25 in. diameter and larger feature segmented energy transfer segments for easy removal and cleanings (per the application requirements). The polymer media segments are lightweight and can be lifted by a single person. This section briefly describes how to determine the need for cleaning and, if necessary, clean the wheel segments.

WARNING
When cleaning polymer media segments, DO NOT use acid based cleaners, aromatic solvents, temperatures in excess of 170°F, or steam. Damage to the media segments may result from improper cleaning.

Classes of Air

Cleaning the energy transfer media will help maintain optimal performance. The frequency of cleaning is largely dependent on the application and air quality. Using ASHRAE’s Classes of Air categories in Table 17 to understand the application and to create a routine cleaning schedule.

Determine Cleaning Frequency

Carrier offers general guidelines for removal and cleaning of the energy transfer media. See Table 17 based on ASHRAE’s Classes of Air categories. Actual cleaning frequency should ultimately be determined based on the results of the annual inspection using Table 18.

Table 17 — Classes of Air

CLASS	DESCRIPTION	EXAMPLES
Class 1 - Clean Air	Air has low contaminant concentration with inoffensive odor and sensory irritation intensity.	<ul style="list-style-type: none"> • Office Spaces • Classrooms • Assembly Rooms • Churches • Corridors
Class 2 - Moderately Clean Air	Air has moderate contaminant concentration, with mildly offensive odors or sensory-irritation intensity.	<ul style="list-style-type: none"> • Rest Rooms • Swimming Pools • Dining Rooms • Locker Rooms • Warehouses • Dorms
Class 3 - Dirty Air	Air has significant contaminant concentration and significant offensive odor or sensory-irritation intensity.	<ul style="list-style-type: none"> • Kitchens • Dry Cleaners • Beauty Salons • Laboratories • Pet Shops
Class 4 - Dirty Air	Air has highly objectionable fumes or gases and potentially contains dangerous particles, bio-aerosols, or gases at a concentration high enough to be considered harmful, not suitable for recirculation or transfer to any other space.	<ul style="list-style-type: none"> • Paint Spray Booths • Laboratory Fume Exhaust • Kitchen Grease Exhaust

Table 18 — Recommended Cleaning Schedule

CLASS OF AIR	CLEANING FREQUENCY
Class 1 - Clean Air	Every 8-10 years
Class 2 - Moderately Clean Air	Every 4-6 years
Class 3 - Dirty Air	Every 1-2 years
Class 4 - Dirty Air	N/A

IMPORTANT: When applied to smoking or industrial environments with visible airborne contaminants, Carrier recommends inspection and cleaning once or twice per year to maintain optimal performance.

Cleaning Requirements

Cleaning requirements vary by application. All surfaces exposed to an air stream will need to be cleaned over time. Generally, rotary energy recovery wheels self-clean when exposed to small amounts of dry dust and dirt as the wheel rotates between two counter flowing air streams.

However, when exposed to air streams containing oils, VOCs, aerosols, or smoke, these contaminants will build on the surface of the media to reduce its energy transfer effectiveness.

Visual Inspection

Annual inspection of the media surface during preventative maintenance checks is recommended. Check both sides of the wheel. Mild discoloration on the surface of the media is normal.

Cleaning Methods

To clean a buildup of dry contaminants on the media surface, brush or vacuum the surface on both sides to remove all debris, including between the layers of polymer. Clean, unobstructed passageways provide the maximum energy savings for the lowest operating cost.

To clean media surfaces that have a buildup of contaminants, Carrier recommends soaking the segment overnight to effectively remove all contaminants and restore the heat/moisture transfer performance.

There are several methods to remove contaminant buildup:

- The best method of removing buildup is to soak the segment overnight in a 5% solution of a non-acid based coil cleaner. After soaking, rinse the segments until the water runs clear and then allow excess water to drain prior to re-installing the segments. A small amount of moisture on the media will be dried out by the airflow.
- Another option is to run water from a hose through the removed media while brushing.
NOTE: This method is not as effective as the overnight soak.

NOTE: Discoloration of Media Surface - Once clean, media segments may remain slightly discolored. Surface discoloration does not affect the performance of the wheel.

Optional Cleaning Method

- If a tub is not available for soaking, a makeshift tub can be easily constructed out of wood boards and any waterproof material, such as a polyethylene sheet. The non-acid based coil cleaner is not corrosive to the polymer media or polyethylene sheet.
- For applications with multiple identical wheels, keeping a spare set of segments available can eliminate system disruptions during cleaning. Contact Carrier for more information.

SEGMENT REMOVAL/INSTALLATION

The procedure to remove and install the energy transfer media varies by size. See Fig. 27 for wheel sizes.

NOTE: Procedures vary by wheel size. Carrier utilizes wheels that are offered in the following sizes:

- Small Segmented (25 to 30 in., 4 segments): See “25 to 30 inch Segmented Wheel Removal” on page 51 for instructions.
- Medium Segmented (36 to 86 in., 6 or 8 segments): See “36 to 86 inch Segmented Wheel Removal” on page 52 for instructions.



Fig. 27 — Available Wheel Sizes

25 to 30 inch Segmented Wheel Removal

Remove or install opposing segments to minimize wheel imbalance. See Fig. 28 for example.

⚠ WARNING

An uneven number of segments in the wheel will cause the wheel to accelerate in rotation. Minimize wheel imbalance and unwanted rotation during service by installing or removing opposing segments for even weight distribution.

Failure to maintain control of the wheel rotation while removing or installing segments could cause severe injury to fingers or hands.

⚠ WARNING

Before servicing entire HVAC system, turn off the main disconnect to the unit. Use the site-specific lockout-tagout procedure.

The tools needed to adjust the wheel are:

- Flathead screwdriver
- Gloves

To remove the wheel follow Steps 1 to 7.

1. Disconnect power from wheel.
2. Remove cabinet covers to gain access and slide wheel frame out of cabinet (if applicable).
3. Position first segment to be removed at the top of the wheel. See Fig. 28 for segment removal example.
4. From the pulley side, unhook the flexible retaining strap on each side of the segment from the wheel rim and then remove both straps. See Fig. 29 retainer strap removal example.
5. Use hand pressure from the motor side to remove segment from the spokes while supporting front with your other hand (segment slides straight out). See Fig. 30 for segment removal.
If necessary, use a flathead screwdriver or pry-bar at the top corner of the segment. Be careful not to bend the segment frame or wheel rim.
6. Rotate wheel and remove remaining two retaining straps. See Fig. 29 for retainer strap removal.
7. Remove the remaining segments.

Wheel Installation (25 to 30 inch)

To install the wheel segments for 25 to 30 inch follow Steps 1 to 4.

1. Ensure that power is disconnected from wheel.
2. From the pulley side, install each of the four segments by sliding them straight into the wheel opening. See Fig. 30 for segment removal.
NOTE: The face of the segment with the embedded stiffener must face the motor side of the wheel. See Fig. 31 for example.
3. Install the flexible retaining straps by inserting the ends under the hub plate and then into the slot on the rim at the end of the spoke. See Fig. 29 for retaining strap removal.
4. Confirm that segments and straps are firmly retained in the wheel structure before applying power to the wheel.

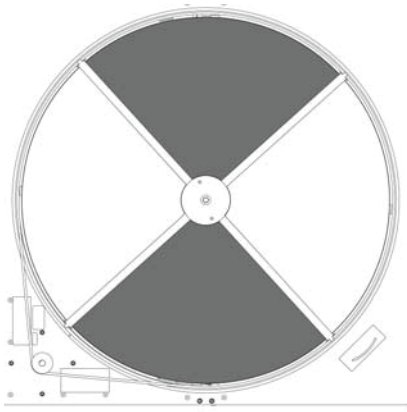

Fig. 28 — Remove/Install opposing segments (25 to 30 in.)



Fig. 30 — Segment Removal



Fig. 29 — Retainer Strap Removal



Fig. 31 — Embedded Stiffener Facing Motor Side

36 to 86 inch Segmented Wheel Removal

Remove or install opposing segments to minimize wheel imbalance. See Fig. 32 for opposing segment removal or installation example.

⚠ WARNING

An uneven number of segments in the wheel will cause the wheel to accelerate in rotation. Minimize wheel imbalance and unwanted rotation during service by installing or removing opposing segments for even weight distribution. Failure to maintain control of the wheel rotation while removing or installing all segments could cause severe injury to fingers or hands. Always close and secure segment retaining latches before rotating wheel.

⚠ WARNING

Before servicing entire HVAC system, turn off the main disconnect to the unit. Use the site-specific lockout-tagout procedure.

The tools needed to adjust the wheel are:

- Flathead screwdriver
- Gloves
- 3/16 inch Allen wrench (for ERC 81 and ERC 86)

To remove the wheel follow Steps 1 to 9.

1. Disconnect power from wheel.
2. Gain access to wheel and slide wheel frame out of cabinet (if applicable).
3. From the pulley side, rotate segment to be removed to the top of the wheel.
4. Using a flathead screwdriver, unlock and open the two segment retaining latches, at the outer corners of the segment to be removed. See Fig. 33 for example of releasing retaining latches.
5. For ERC-81 and ERC 86, use a 3/16 in. Allen wrench to remove the nose bolt securing the segment to the hub plate. See Fig. 34 for example to remove the nose bolt.
NOTE: Nose entering hub plate (ERC 81-86 ONLY) includes a screw).
6. Remove segment by sliding outer portion of segment out first before disengaging the nose. See Fig. 32 for segment removal. A flathead Screwdriver may be used to aid segment removal. Be careful not to bend the segment frame or wheel rim.
7. Once segment is removed, close both latches.

⚠ WARNING

The wheel is now unbalanced.

8. Slowly rotate wheel 180-degrees and remove the opposing segment to rebalance the wheel. See Fig. 32 for removal example.
9. Remove the remaining segments by repeating the previous three steps.

Wheel Installation (36 to 86 inch)

To install the wheel segments for 25 to 30 inch follow Steps 1 to 7.

1. Ensure that power is disconnected from wheel.
2. Begin by positioning one empty segment bay at the top of the wheel and opening the two retaining latches. See Fig. 33 to release retaining latches.
NOTE: The face of the segment with the embedded stiffener must face the motor side of the wheel. Refer to Fig. 31 for example.
3. From the pulley side, slide segment into place nose first, then push outer portion of segment in to wheel frame. If you are installing an ERC-81 or ERC-86, use a 3/16 in. Allen wrench and the nose bolt to secure the segment to the hub. See Fig. 34 for segment placement.
4. Close the retaining latches on outer corners of segment to secure the segment inside the wheel. See Fig. 33 for example of closing the retaining latches.
5. Rotate first segment 180-degrees and install the opposing segment to rebalance the wheel. See Fig. 32 for example of installing opposing segments.
6. Repeat until all of the remaining segments are installed, ensuring balance throughout the procedure. See Fig. 32 for example of installing opposing segments.
7. Apply power to wheel to confirm rotation.

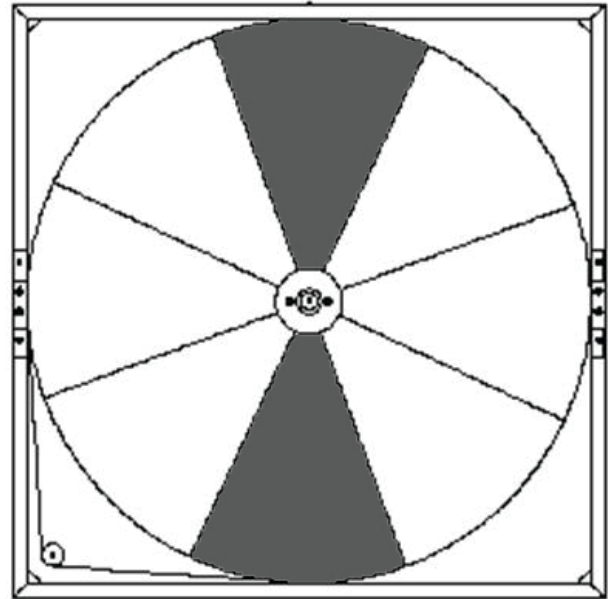

Fig. 32 – Remove/Install Opposing Segments (36 to 86 in.)

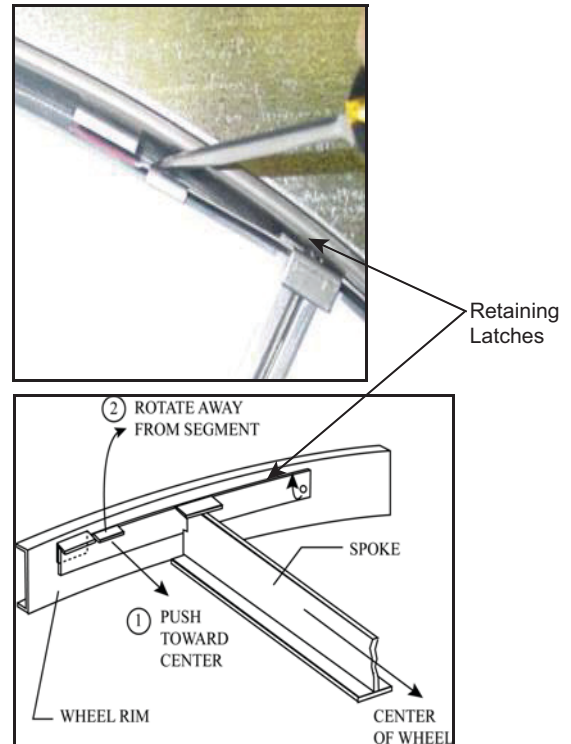

Fig. 33 – Release Retaining Latches

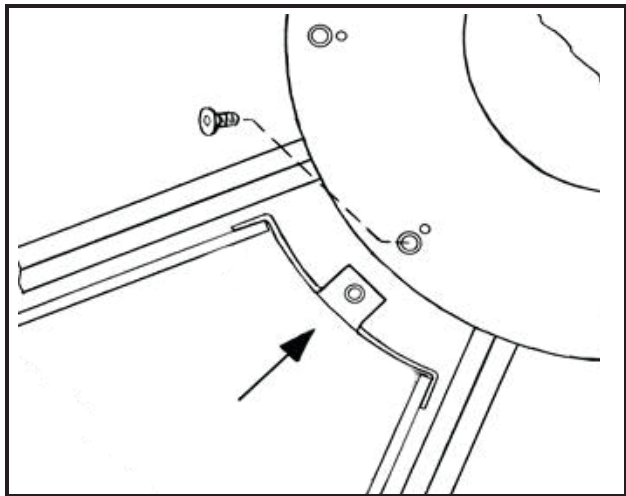

Fig. 34 — Nose to Hub Plate (ERC 81-86 ONLY includes screw)

Use Table 19 to record product information for use when ordering replacement parts and planning maintenance schedules.

Table 19 — Energy Recovery Wheel Product Information

MODEL	SERIAL NUMBER	DATE INSTALLED	LOCATION

Gas Heater

GAS LINE

Check for gas leaks.

MANUAL SAFETY SHUT OFF VALVE

Check for gas leaks.

DIRECT SPARK IGNITER

Check for cracked ceramics, excessive carbon residue, or erosion of the electrode. Replace as required.

GAS VALVE

Check that gas valve seat is not leaking.

BURNERS

Soft brush or vacuum inside burner, at burner ports, and at air inlet between burner and manifold pipe to eliminate accumulation of lint and/or dirt.

HEAT EXCHANGER

Inspect for cracks, sagging, bending, or distortion. Clean with vacuum and/or stiff brush.

DRAFT INDUCER

Clean with compressed air or vacuum.

VENT PIPE/TERMINAL

Venting must be intact. Using a flashlight, look for obstructions, cracks on the pipe, gaps in the sealed areas, or corrosion. Clean vent terminal.

CONDENSATION DRAIN

Check for blockages.

Electric Heater Wiring and Wiring Connections

Check all wiring connections. Tighten as necessary. Check internal wiring. Replace as necessary with type THHN 221°F (105°C), 600-v, 16-gauge wire or equivalent.

CONTROL PANEL

Check control panel, VFD, auxiliary heater controls (if equipped), and all electronics for dust/dirt and moisture. Clean as necessary.

NOTE: Certain applications may require an increased cleaning frequency to electronics and control components due to very dusty environments. If the application requires a higher tier VFD enclosure, contact application engineering to submit a Special Order request.

HEATING ELEMENTS

Check heating elements for dust/dirt buildup and/or broken elements. Replace elements and/or clean elements with low pressure air as necessary. Check element male/female chassis insulators for breaks and/or cracks. Replace as necessary. Check element support frame insulators. Replace missing or broken insulators as necessary.

Filters

Filters should be checked for dirt restriction on a monthly basis (or as required). Replace filters with filters of equal specification when they appear dirty.

TROUBLESHOOTING

See Tables 20-26 for possible causes and solutions to problems that may arise.

Table 20 — Supply Fan

PROBLEM	POSSIBLE CAUSE	SOLUTION
Blower motor does not run.	Damper limit switch not closed or inoperative.	Repair or replace switch.
	Motor thermal overloads tripped.	For tripped condition - reset.
	Fuses blown or missing.	Replace fuses.
	External power source lacking.	Have incoming power lines checked.
	Motor inoperative.	Repair or replace.
Blower motor runs, but fans do not supply enough make-up air.	Intake filters dirty.	Replace or clean.
	Obstruction in the intake.	Check dampers for proper operation. Clear all intake passages of obstructions.
	Fan wheel loose on shaft.	Reposition and tighten.
	Access doors and panels not closed.	Close.
	Excessive discharge resistance from: • Dirty filters in discharge • External dampers	Clean filters and/or re-adjust dampers.
Excessive fan noise.	Fan motor bearing.	Replace.
	Fan wheel loose on shaft.	Reposition and re-tighten.
	Fan wheel rubbing.	Loosen setscrews. Reposition cone and tighten.
	Fan wheel dirty.	Clean.
	Loose duct.	Tighten or reinforce.
	Foreign article in fan or duct.	Remove.

Table 21 — Compressor

PROBLEM	POSSIBLE CAUSE	SOLUTION
Compressor will not start.	Power off, loose electrical connections or fuse open.	Check disconnect switch, fuses and wiring.
	Compressor contactor not closing.	Check voltage to contactor coil, transformer slave relay, thermostat.
	Internal compressor thermal overload open.	If compressor is hot, allow 2 hours to cool.
	Compressor defective.	Check compressor for electrical failure. Compressor may be seized; check for lock rotor amps (LRA).
	High or low pressure switch open or defective.	Check calibration of high or low pressure switch.
	Oil pressure control open or defective.	Check oil failure control.
Compressor starts but cuts out on low pressure switch.	Low on refrigerant.	Check sight glass and check pressures.
	Airflow restricted.	Check for dirty evaporator coil, dirty filters, dampers closed, iced evaporator, VFD settings, check motor amps, duct design.
	Restriction in liquid line.	Check head pressure. Check and adjust TXV, if not functioning properly. Check pressure drop across filter drier.
	Defective low pressure switch.	Check calibration of switch.
Compressor starts but cuts out on high pressure switch.	Refrigerant overcharged.	Check pressures and charge by subcooling.
	Condenser fan control has incorrect setting.	Check calibration of the low ambient control.
	Fan motor defective.	Check fan motor.
	Condenser coil inlet obstructed or dirty.	Check coil and inlet clearances and for possible air recirculation.
	Air or non-condensables in system.	Compare liquid refrigerant pressure with the saturated pressure. If the presence of air or non-condensables is suspected, the refrigerant must be reclaimed through a service port. The system must then be re-evacuated to 250-500 microns and recharged. The filter-drier should also be replaced before charging.
	Defective high pressure switch.	Replace switch.
Compressor cuts out on thermal overload.	Restriction in discharge or liquid line.	Check discharge and liquid line pressures. Check TXV.
	Low voltage.	Check incoming voltage leg-to-leg. All three legs must be within 10% of the required voltage and the leg-to-three-leg average voltage variation must be less than 2% on each leg.
	Sustained high discharge pressure.	Check running amperage and conditions described under high discharge pressure.
	High suction and discharge pressures.	Check TXV setting. Check for air in system.
	Defective compressor overload.	Allow compressor to cool for two hours if compressor is hot. Recheck for open circuit.
	Defective run capacitor.	Check run capacitor for compressor and fan motor.
	Improper refrigerant charge.	Check subcooling.
	Bearings or pistons too tight.	Check for low oil level.
Allow time for compressor to cool.	Check dome temperature of compressor.	
Noisy compressor.	Scroll compressors are rotation sensitive.	Reverse wiring at disconnect switch may require blower to be rechecked for rotation.
	Refrigerant overcharged.	Check pressures and subcooling.
	Excess or insufficient oil in compressor crankcase.	Check oil level on hermetic compressors. Check total equivalent feet of piping. Add oil, as recommended.
	Liquid flood-back.	Check TXV setting. Refrigerant overcharge refrigerant circuit problem.
	Cyclical noise pattern.	Digital compressors have a significant shift in generated noise when running unloaded.
Unit shutdown (A2L alarm)	Compressor defective.	Replace compressor.
	A2L sensor contact is closed.	Check for refrigerant leaks. Check for faulty leak detection sensors.

LEGEND

TXV — Thermal Expansion Valve
VFD — Variable Frequency Drive

Table 22 – Refrigeration Circuit

PROBLEM	POSSIBLE CAUSE	SOLUTION
Noisy operation.	Air noise	Check ductwork. Air velocity too high.
	Chattering contactor.	Check for adequate control voltage. Check for shorts or breaks. Check thermostat. Check contactor points.
	Tubing rattle.	Dampen by taping or clamping. Bend tubing away from contact, where possible.
High suction pressure.	Excessive load on evaporator coil.	Check for high entering wet bulb temperature. Check for excessive airflow.
	Broken compressor valves. Scroll compressors do not have valves.	Scroll compressors should not be pumped down below 5 PSI.
	Compressor is unloaded.	Recalibrate unloader pressure switch.
	Leaking check valve	Check temperature across check valve.
	Expansion valve not secured to suction line or TXV defective.	Check the TXV, ensure bulb is insulated.
High discharge pressure.	TXV setting.	Check TXV setting and calibrate superheat.
	Air inlet to condenser dirty or obstructed.	Check for proper clearances and possible air recirculation.
	Condenser fan, motor defective.	Check condenser fan motor and run capacitor.
	Condenser fan control has incorrect setting.	Check calibration of low ambient head pressure control.
Suction pressure too low.	Refrigerant undercharge.	Check pressures and subcooling.
	Blower running backwards.	Interchange any two wires connected to motor.
	Defective or improperly adjusted expansion valve.	Check superheat and adjust TXV.
	Dirty filter.	Check filter and evaporator coil.
	Too little airflow or low entering air temperature.	Check airflow and entering air wet bulb conditions.
	Restriction in suction or liquid line.	Check refrigerant circuit for restriction.
Head pressure too low.	Insufficient refrigerant charge.	Check subcooling. Check for leak.
	Defective or improperly adjusted expansion valve.	Check superheat and adjust TXV.
	Low suction pressure.	See above – suction pressure too low.
	Condenser fan control setting.	Check calibration of low ambient control.
	Defective compressor	See above – high suction pressure.
Compressor short cycles.	Thermostat location or malfunction	Check thermostat. Check heat anticipator setting.
	Improper refrigerant charge.	Check subcooling. Verify superheat.
	Defective high or low pressure control.	Check high or low pressure switch.
	Cycling on internal overload.	Possible tight bearings – see above.
	Defective expansion valve.	Check TXV and superheat.
	Poor air distribution.	Check ductwork for recirculation.
	High discharge pressure.	See above – high discharge pressure.
	Leaking discharge valves in compressor.	See above – high suction pressure.
Running cycle too long or unit operates continuously.	Refrigerant undercharged.	Check subcooling.
	Dirty filter or evaporator coil	Check filter, coil and airflow.
	Dirty or clogged condenser coil.	Check coil and airflow.
	Air or other non-condensables in system.	Check equalized high side pressure with equivalent outdoor temperature.
	Defective compressor	See above – high suction pressure.
	Restriction in suction and liquid line	Check for restrictions in refrigerant circuit.
	Control contacts stuck.	Check thermostat, shorts in wiring, slave relay compressor contactor.
Supply air temperature too high	Refrigerant undercharge or leak in system.	Check subcooling and check for leaks.
	Evaporator plugged with dirt or ice.	Check evaporator, airflow, and filter.
	Improperly adjusted or defective expansion valve.	Check superheat and adjust TXV. Check bulb.
	Defective compressor.	Check compressor for proper operation.
	High discharge pressure.	See above – high discharge pressure.
	Airflow is too high.	Check external static pressure.
Supply air temperature too low	Airflow is too low.	Check evaporator coil, filter. Check for closed dampers, grills, drive for loose parts, belts, misalignment. Check external static pressure.
	Return air temperature too low.	Check entering air wet bulb conditions.
Liquid line too hot	Refrigerant undercharged.	See above – high discharge pressure.
	High discharge pressure.	Restriction upstream at point of frosting.
Suction line frosting	Insufficient evaporator airflow.	Check airflow. Check fan VFD, closed dampers.
	Restriction in suction or liquid line.	Restriction upstream at point of frosting.
	Malfunctioning or defective expansion valve.	Check bulb of TXV.
Blower motor not running	Improper wiring.	Check wiring diagram.
	Defective motor.	Check motor controller.
	Defective thermostat or control circuit.	Check “R” and “G” circuit.
	Motor off on overload protector	Allow motor to cool. Check amperage.

Table 23 — Variable Speed Head Pressure Control

PROBLEM	POSSIBLE CAUSE	SOLUTION
No fan operation.	No 24-v control voltage	Check for 24 VAC at control.
	No input pressure to control	Check alignment of capillary fitting. Schrader valve depressor must depress Schrader valve enough to allow pressure into capillary.
	Bad fan motor	Disconnect power. When P266 is used, place a jumper from L1 to M1 and connect power. If fan does not start, motor is bad and should be replaced.
	Pressure transducer problem	Disconnect 6 pin connector from right side of control. Place a jumper wire between third pin from the top and bottom pin on the control (not the cable). If fan goes to full speed, check for input pressure. If it has been determined there is adequate pressure, the transducer is bad and the control must be replaced.
Fan stops when pressure reached high end of operating range.	Control is not wired correctly	See "Typical Wiring Diagram" on page 36.
No fan modulation (on-off operation).	Control is not wired correctly	See "Typical Wiring Diagram" on page 36.
Fan starts at full speed.	Control is not wired correctly	See "Typical Wiring Diagram" on page 36.
Erratic fan operation.	Control is not wired correctly	See "Typical Wiring Diagram" on page 36.
	Dirty or blocked condenser coil.	Clean condenser coil.
Fan motor is cycling on thermal overload.	Dirty or blocked condenser coil.	Clean condenser coil.
	Wrong motor for fan speed control application.	Replace with motor approved for fan speed control application.
Erratic pressure control.	Defective regulator.	Replace defective part.
	Dirt causing regulator to bind.	Disassemble regulator and clean internal parts. Install strainer.
	Power source to hot gas solenoid or operation of the solenoid is intermittent.	Determine if problem is caused by supply voltage, solenoid, or excessive MOPD. Make changes necessary to correct problem.
Regulator leakage.	Dirt in regulator causing seat to remain open.	Clean regulator. Install strainer.
	Worn or eroded seating surface on regulator.	Replace defective part.
Regulator hunting (chattering) with large fluctuations in controlled pressures.	Regulator is oversized.	Contact a certified technician for correctly sized regulator.
	Regulator and liquid injection thermovalve have control interaction.	Increase superheat setting. Dampen bulb response by repositioning.
	Regulator and cylinder unloaders have control interaction.	Increase differential between the controls by lowering the regulator's set point.
Regulator will provide pressure control.	Regulator seat is restricted.	Locate and remove stoppage. Install strainer.
	Pressure adjusting stem is set at a point so high that suction pressure never reaches the set point.	Re-adjust the regulator.
	Strainer clogged at the regulator inlet.	Locate and remove stoppage.
	MOPD exceeded across the solenoid or loss of source voltage.	Replace solenoid or troubleshoot the electrical problem.
	Solenoid coil burned out.	Replace coil.
	Wrong type of distributor for hot gas bypass to the evaporator.	Install proper Venturi-Flo [®] type distributor for low pressure drop.
Regulator fails to close.	Dirt under seat of regulator.	Locate and remove stoppage. Install strainer or filter drier.
	Diaphragm failure (leakage around the adjusting stem).	Replace defective parts.
	Pressure adjusting stem is set at a point so high that suction never reaches the set point.	Re-adjust the regulator.
	Blocked external equalizer passage.	Locate and remove stoppage. Install strainer.
	Worn or eroded regulator seat.	Replace defective part.

NOTE(S):

a. Third-party trademarks and logos are the property of their respective owners.

LEGEND

MOPD — Maximum Opening Pressure Difference

Table 24 – Energy Wheel Conservation

PROBLEM	POSSIBLE CAUSE	SOLUTION
Inadequate wheel performance.	Incorrect wheel rotation speed.	Check wheel rotation speed.
	Worn wheel media or worn/out-of-place seals.	Check wheel integrity and seals. Adjust and/or replace seals.
	Unanticipated entering air conditions.	Check entering air conditions and compare to design.
	Dirty media.	Check media for dirt and clean.
Improper wheel rotation.	Misaligned belts.	Check drive belts for engagement with sheaves.
	Improper motor operation.	Check drive motor and drive motor wiring for proper voltage.
	Improper VFD operation.	Check VFD programming.
	Improper VFD sensor operation.	Check VFD input sensor (temperature/relative humidity) for malfunctioning.
High pressure drop.	Unanticipated airflow.	Check airflow and compare to design.
	Dirty filters.	Check filters and clean/replace.
	Dirty media.	Check media for dirt and clean.
Noise.	Out-of-place seals.	Check seals and adjust.
	Worn bearings.	Check bearings.
	Misaligned belts.	Check belts for slippage.

Table 25 – Gas Heater

PROBLEM	POSSIBLE CAUSE	SOLUTION
Steady on - No operation.	Internal control fault.	
One flash - Combustion airflow fault.	Faulty combustion blower.	Check for 230-v supply and tightness at fan connections. If no power, replace.
	Airflow switch not closing.	
	Airflow switch opened during operation.	
Two flashes - Flame with no call for heat.	Faulty gas valve.	Check voltage to gas valve with thermostat off. Valve should not be powered. If there is gas flow, replace valve.
Three flashes - Ignition lockout. ^a	Ignition control miscommunication.	Reset ignition control by removing 24-v power to ignition control terminal 24 VAC.
	Dirty burners.	Clean burners to ensure proper flame carryover.
	Faulty spark igniter.	Check if connecting lead or spark igniter are damaged. If yes, replace.
	Faulty flame sensor.	Check if connecting lead or flame probe are damaged and/or touching earthed components. If yes, replace.
	Incorrect gas pressure at gas valve.	Check that the gas pressure at inlet of valve is correct for the gas type. If not, correct pressure problem.
	Faulty gas valve.	Check that the gas pressure at outlet of the valve rises when valve turns on and returns to zero, or lower, when valve turns off. If not, replace.

NOTE(S):

a. LED flashed on for 0.25 seconds and off for 0.25 seconds during fault condition. The pause between fault codes is 3 seconds.

Table 26 – Electric Heater

PROBLEM	POSSIBLE CAUSE	SOLUTION
No heat.	No call for heat.	Check that the controls are set to call for heating.
	No power and control voltage to heater.	Check that heater has power and control voltage.
	Faulty component.	Check components with continuity meter. Replace as necessary.
Not enough heat.	Faulty component.	Check that ampere draw is reasonably close to that on the heater data plate. If more than 10% short, begin testing individual components. Replace, as necessary.
	Heat anticipator current draw too low, causing short cycling.	Check current draw.
Heater cycling on automatic limit.	Improper airflow.	Check for obstructions to return air, loose or broken fan belt, and clogged filters and/or evaporator coils.
	Faulty temperature limit switch.	Test, and if necessary, replace.
Open secondary protective device.	Stuck contactor.	Check contactor.
Contractor chatter.	Improper wiring.	Check wiring.
	Insufficient transformer capacity.	Check transformer.
Element failure.	Corroded hardware and/or loose connections.	Check hardware.

