



Product Data

Vertical and Horizontal Unit Ventilator

Models 40UV,UH

750 to1500 Nominal cfm

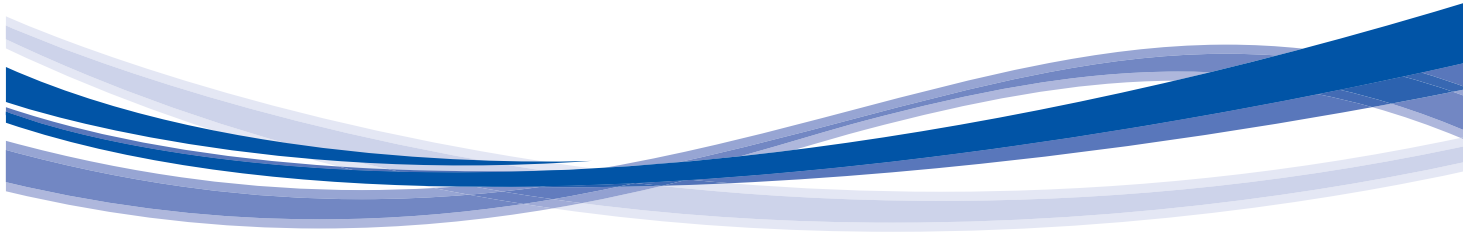

40UV

40UH

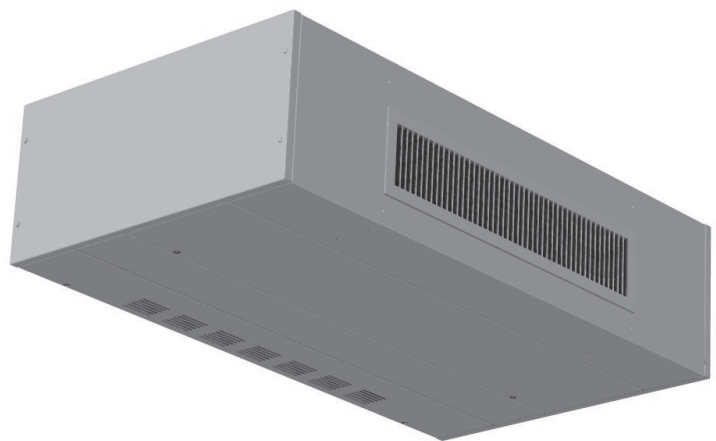

40UV/UH Size 0750 to1500
Floor and Ceiling Mounted Unit Ventilator

The 40UV and 40UH unit ventilators are designed to be tough, dependable, aesthetically pleasing, quiet, and easy to install.

Carrier’s 40U unit ventilators offer:

- Strict indoor air quality to meet requirements of schools, hospitals, and institutions.
- Heavy duty construction that incorporates a draw-thru design.
- Discharge temperature controlled using either a face-and-bypass damper or modulating control valve.
- Available adapter backs in various configurations to allow for easy upgrades to existing systems, and optional factory installed controls which have been engineered to ease installation.
- Configurability for direct expansion (DX) cooling, chilled water, hot water, steam, or a combination of both chilled and hot water (two pipe and four pipe configurations), chilled water and steam, DX and hot water, or DX and steam.
- Construction in accordance with UL and CSA standards with a label affixed to the unit listing the product code under which it is registered.

Cabinet

Prior to assembly, the cabinet parts shall be degreased and coated with an electrostatically applied baked-on polyester powder paint and be insulated with acoustic foam containing no fibrous materials. The foam insulation shall have a fire rating of UL94 HF1.

For floor mounted units, the exterior panels of the cabinet shall be constructed of 16 gauge sheet metal. For ceiling mounted units, the exterior panels of the cabinet shall be constructed of 18 gauge sheet metal.

The front panel and compartment panels shall be easily removable with tamper-proof fasteners securing the panels to the rest of the unit cabinet. The back of the cabinet shall have an opening for connection to a wall sleeve and louver.

Control panel

The control panel is located in the left-hand compartment. All components located in the panel shall be clearly marked for easy identification. All terminal blocks and wire shall be individually numbered. All electrical wires in the control panel shall be run in an enclosed trough. Wiring outside of the control panel shall be run in protective sleeves.

The unit will be provided with a power disconnect sized for the full load amperage of the unit to enable the unit to be disconnected from the power supply prior to any maintenance.

The 3-speed selector switch enables adjustment of the supply air volume. Reduction in fan speed shall be achieved by a step down multi-tap transformer.

Water/steam coil

Large surface area slab coils for optimize heat transfer and airflow.

Evaporator

All direct expansion units include a factory installed thermal expansion valve and utilize large surface area

evaporator coils ideally positioned to optimize heat transfer and airflow. Each evaporator is manufactured from refrigeration quality copper tubes with mechanically bonded aluminum fins. Evaporator coils include a factory-installed low limit stat.

Coil and TXV are rated for use with R-454B refrigerant and include a UL approved refrigerant detection systems and mitigation controls.

Drain pan

Each unit shall be fitted with a 20 gauge, 304 stainless steel welded construction drain pan sloped in 3 directions. The condensate drain pan connection will be located on the same side as the cooling coil connection and include a 3/4 in. reinforced condensate tubing and splashguard over the drain port.

Supply fan

Supply airflow is provided by a double inlet, forward curved, centrifugal type fan with offset aerodynamic blades. The assembly shall be statically and dynamically balanced to ensure smooth running and minimum noise levels. The fan assembly shall be positioned for a “draw-thru” configuration.

Fan motor

The fan motor is an electronically commutated type complete with integral automatic thermal overload protection. The fan and motor assembly shall be direct drive type with motor and bearings positioned outside of the airstream.

Table of contents

	Page
Features/Benefits	2
Model Number Nomenclature	3
Physical Data	4
Options and Accessories	5
Base Unit Dimensions	16
Performance Data	20
Electrical Data	27
Application Data	28
Controls	36
Guide Specifications	39

Model number nomenclature



1-3	4	5	6-9	10	11	12	13	14	15	16	17	18	19	20	21	22	23	24
40U	V	1	1000	A	A	4	2	A	1	C	B	2	A	B	1	C	N	N

Series
40U

Style
V - Floor Mounted Flat Top (Vertical)
H - Ceiling Mounted (Horizontal)

Cooling Control
1 - Valve Control
2 - Face and Bypass

Unit Size
0750- 750 cfm
1000- 1000 cfm
1250- 1250 cfm
1500- 1500 cfm

Inlet Air Arrangement
Floor Mounted Flat Top, 16-5/8" Deep, Front RA
A = Rear OA Open Piping Tunnel
B = Rear OA Closed Piping Tunnel
D = No OA Open Piping Tunnel
Floor Mounted Flat Top, 21-7/8" Deep, Front RA
E = Rear OA Piping Passage Unit
F = Rear OA Full Adapter Back
G = Top Window Intake, Closed PT
J = Closed Back, Closed PT
K = 2" Step-Down, Open PT
L = 2" Step-Down, Closed PT
Ceiling Mounted Units
M - Bottom RA, Rear OW
N - Bottom RA, Top OA
P - Rear RA, Top OA
Q - Rear RA, Rear OA
R - Bottom RA, No OA
S - Rear RA, No OA

Discharge Air
40UV – FLOOR (VERTICAL) UNITS
A = Top Discharge Bar Stock Steel Grille
40UH – CEILING (HORIZONTAL) UNITS
E - Ceiling Mtd with Front Disch Duct Collar
F - Ceiling Mtd with Front Disch Dbl Defl Grille
G - Ceiling Mtd with Down Disch Dbl Defl Grille

Cooling Coil Type
0 - None
2 - 2-Row Chilled Water/Hot Water 2-Pipe
4 - 4-Row Chilled Water/Hot Water 2-Pipe
5 - Direct Expansion Cooling Only

Heating Coil Type
0 - Chilled Water/Hot Water 2-Pipe
1 - 1-Row Hot Water Coil
2 - 2-Row Hot Water Coil
3 - Steam Coil (1-Row)
N - None

Coil Access
A - Right Hand Coil(s)
B - Left Hand Coil(s)
C - RH Cooling - LH Heating
D - LH Cooling - RH Heating

Hot Water Heating Piping Package
40UV - FLOOR (VERTICAL) UNITS ONLY
D - 2-Way Valve, All Components
H - 3-Way Valve, All Components
N - None

Chilled Water Piping Package
40UV - FLOOR (VERTICAL) UNITS ONLY
N - No Valves
D - 2-Way Valve^a
H - 3-Way Valve^a

Filters
A - 70-75% Arrestance
B - MERV10
C - MERV13

Generation
1 - First Generation
2 - Second Generation (DX coil only)

Control Type
A - No Controls (all field-installed)
B - DDC Ready
U - Carrier UV Controls (Future)

Electrical Connection
A - Left Hand Side
B - Right Hand Side

Fan Motor Type
2 = High Static ECM – 3-Speed Switch
3 = High Static ECM – Variable Speed (0-10 vdc)
4 = Standard ECM – 3-Speed Switch
5 = Standard ECM – Variable Speed (0-10 vdc)

Supply Voltage
A - 115/60/1
B - 208/60/1
C - 230/60/1
H - 277/60/1

Outdoor Air Damper
C - Insulated Damper
E - No Damper (Recirculating Unit)

Coil Arrangement
0 - Units with One Coil
1 - Preheat: Pos 1 Heating, Pos 2 Cooling
2 - Reheat: Pos 1 Cooling, Pos 2 Heating

NOTE(S):
a. Modulating on Valve Control, 2-Position on Face and Bypass Control.
All 2-way and 3-way valve packages include shut-off valves, strainer, circuit setter, and a balancing valve for 3-way valve units.

40UV/UH Physical Data

UNIT 40UV, UH		0750	1000	1250	1500
NOMINAL AIRFLOW (cfm)		0750	1000	1250	1500
SUPPLY FANS					
Type		Direct Drive Centrifugal			
Fan Quantity		2	3	4	4
Fan Diameter (in.)		8.06	8.06	8.06	8.06
Fan Width (in.)		7.15	7.15	7.15	7.15
Airflow (High/Medium/Low)	cfm	750/650/500	1000/750/600	1250/900/750	1500/1100/900
	l/s	354/307/236	472/354/283	590/425/354	708/519/425
SUPPLY FAN MOTOR					
Standard Motor (Digit 16 = 4 or 5)					
Motor Type		ECM - Electronically Commutated Motor			
Motor Size - Qty 1 hp (kW)		1/3 hp (0.25)	1/3 hp (0.25)	1/3 hp (0.25)	1/3 hp (0.25)
Max. External Static Pressure (in. wg)		0.05	0.05	0.05	0.05
High Static Motor (Digit 16 = 2 or 3)					
Motor Type		ECM - Electronically Commutated Motor			
Motor Size - Qty 1 hp (kW)		1/2 hp (0.37 kW)	1/2 hp (0.37 kW)	1/2 hp (0.37 kW)	1/2 hp (0.37)
Max. External Static Pressure (in. wg)		0.25	0.25	0.25	0.25
COIL WATER VOLUME gal. (L)					
1-Row		0.32 (1.2)	0.38 (1.4)	0.44 (1.7)	0.5 (1.9)
2-Row		0.51 (1.9)	0.63 (2.4)	0.76 (2.9)	0.88 (3.3)
4-Row		0.92 (3.5)	1.17 (4.4)	1.42 (5.4)	1.66 (6.3)
DX COIL VOLUME					
DX Coil with Header Volume		94.63 in. ³ (1.55 dm ³)	123.45 in. ³ (2.02 dm ³)	152.41 in. ³ (2.50 dm ³)	180.99 in. ³ (2.97 dm ³)
COIL CONNECTIONS (in. OD)					
Water Coils - Standard Units		Unions with 3/4 in. Female Solder Joint			
Water Coils - Units with Piping Package		Chilled Water: 3/4 in. NPT Drop Ear, Hot Water: 1/2 in. NPT Drop Ear			
Evaporator Coil		3/4 in. OD Suction, 1/2 in. OD Liquid			
Steam Coils		1 in. NPT			
Condensate Line		3/4 in. ID Condensate Line			
UNIT OPERATING WEIGHT (Approximate)					
Floor Mounted, 16-5/8 in. Units		410 lb (186 kg)	470 lb (213 kg)	525 lb (238 kg)	580 lb (263 kg)
Floor Mounted, 21-7/8 in. Units		445 lb (202 kg)	510 lb (231 kg)	570 lb (259 kg)	630 lb (286 kg)
Ceiling Mounted Units		510 lb (231 kg)	580 lb (263 kg)	645 lb (293 kg)	710 lb (322 kg)
AIR FILTERS					
Quantity		1	2	2	2
Dimensions	in.	10 X 36	10 X 24	10 X 30	10 X 36
	mm	254 X 914	254 X 610	254 X 762	254 X 914

LEGEND

- CW** — Chilled Water
- DX** — Direct Expansion
- HW** — Hot Water
- ID** — Inside Dimensions
- OD** — Outside Dimensions

Options and accessories



Available Options^a

OPTIONS OR STANDARD FEATURES	UNIT SERIES — 40U	
	Vertical (floor)	Horizontal (ceiling)
	UV	UH
CABINET CONSTRUCTION		
16 Gauge	Std	N/A
18 Gauge	N/A	Std
COILS		
Chilled Water Coil	X	X
Direct Expansion Evaporator Coil (R-454B duty)	X	X
Hot Water Coil	X	X
Steam Coil	X	X
COIL CONNECTION		
Left Hand	X	X
Right Hand	X	X
RH Cooling/LH Heating	Std	Std
LH Cooling/RH Heating	X	X
STAINLESS STEEL DRAIN PAN	Std	Std
DISCHARGE OPTIONS		
Floor Mounted Bar Grille with Screen	X	N/A
Ceiling Mounted Front Discharge with Duct Collar	N/A	X
Ceiling Mounted Front Disch. with Dbl Defl. Grille	N/A	X
Ceiling Mounted Down Disch. with Dbl. Defl. Grille	N/A	X
DAMPERS		
Outside Air	X	X
Face and Bypass	X	X
CONDENSATE PUMP		
	X	X
COIL POSITION		
Pre-Heat	X	X
Re-Heat	X	X
FILTERS		
Throwaway 1 in. (70-75 arrestance)	Std	Std
1 in. MERV 10	X	X
1 in. MERV 13	X	X
MOTORS		
ECM 3-Speed Switch (high static)	X	X
ECM 0-10 vdc (high static)	X	X
ECM 3-Speed Switch (standard)	X	N/A
ECM 0-10 vdc (standard)	X	N/A
INLET AIR OPTIONS		
Rear Outside Air	X	X
No Outside Air	X	X
Top Outside Air	N/A	X
Front Return Air	X	N/A
Bottom Return Air	N/A	X
Rear Return Air	N/A	X

Available Options^a (cont)

OPTIONS OR STANDARD FEATURES	UNIT SERIES — 40U	
	Vertical (floor)	Horizontal (ceiling)
	UV	UH
PAINT OPTIONS		
Beige	Std	Std
Sky White	X	X
Light Grey	X	X
CONTROLS		
Field Installed By Others	Std	Std
Supply Fan Current Switch Option	X	X
DDC Ready	X	X
Aquastat (2-Pipe changeover)	X	X
Condensate Pan Overflow Switch	X	X
Hot Water Coil Freeze Protection	X	X
ELECTRICAL CONNECTION		
Left Hand Side	Std	Std
Right Hand Side	X	N/A
PIPING PACKAGES		
Modulating Control Valve		
2-way or 3-way (valve control units)	X	N/A
2-position Control Valve		
2-way or 3-way (face and bypass units)	X	N/A
Balancing Valve (Included with 3-way valve package)	X	N/A
Circuit Setter	X	N/A
Drain with Hose Bib	X	N/A
Shut Off Valves	X	N/A
Strainer	X	N/A
VOLTAGE		
115/60/1	X	X
208/60/1	X	X
230/60/1	X	X
277/60/1	X	X

NOTE(S):

a. VRF Compatible DX Coil - ETO only. Contact the application team for ETO availability.

LEGEND

ETO — Engineered to Order
N/A — Not Available
Std — Standard
X — Available As Option

Factory-installed options

Style

Floor-mounted flat top

The unit shall be floor-mounted with adjustable leg levelers. All access and maintenance shall be through the front and the top panels of the unit.

Ceiling mounted

The unit shall be ceiling-mounted using field supplied rods and fasteners. All access and maintenance shall be through the bottom access panels of the unit.

Cooling control

Valve control

The unit shall be furnished with a fixed plate directing 100% of the airflow across the coil(s). Full modulation allowing any mixture of outside air and return air shall be possible. Discharge air temperature is controlled by modulating the optional cooling and/or heating valve(s). The blowers will be located above the coil.

Face and bypass

The unit shall be furnished with a face and bypass section including aluminum opposed blade face and bypass dampers with overlapping neoprene blade tips and jamb seals, and an optional spring return modulating actuator. The face and bypass damper regulates the amount of return air and outside air passing through the coil. The blowers will be located above the coil.

Inlet air

Floor mounted and ceiling mounted units have a variety of inlet air configurations for outside and return air. Refer to "Airflow Arrangements — Inlet Air, Floor Mounted, 16-5/8 in. Depth (Optional 40UV Units)" on page 10 for images on the inlet air configurations available.

Floor mounted units have a built-in pipe tunnel in the rear of the unit. The pipe tunnel allows for field crossover of hot water and/or chilled water piping, electrical conduit, or refrigeration piping without increasing the depth of the unit.

Both open or closed pipe tunnels are available in configurations below:

- The open tunnel provides more space for crossover piping compared to the closed pipe tunnel.
- The closed pipe tunnel includes an insulated back cover for additional insulation and can provide a finished look if the rear of the unit is visible from the exterior of the building.

Floor mounted units with 21-7/8 in. depth can be provided with a 2 in. step-down back adapter. Refer to "Airflow Arrangements — Inlet Air, Floor Mounted, 21-7/8 in. Depth (Optional 40UV Units)" on page 11. The 2 in. step-down allows for the unit to fit against the wall if there are any architectural obstructions below the standard 30 in. unit height.

Discharge air

Floor-mounted bar grille with screen

Floor mounted units have a pencil-proof clear anodized aluminum supply bar grille and 1/4 in. galvanized steel mesh mounted on the top panel.

See "40UV Vertical Unit — 21-7/8 in. Depth — Floor Mounted (Standard)" on page 17 and page 18 for images and dimensions of the top bar grille.

Ceiling mounted front discharge with duct collar

The front discharge duct collar allows for connection to field installed ductwork supplied by others.

Ceiling Mounted Discharge with Double Deflection Grille

The double deflection grille is made of clear anodized aluminum and has adjustable horizontal and vertical louvers to direct air flow. See "40UH Horizontal Unit — Ceiling Mounted — Front Discharge" on page 18 and page 19 for dimensions of the ceiling mounted discharge air options.

Cooling options

2-Row Chilled Water/Hot water 2-pipe

Two-row slab coil assembly for chilled water only or 2-pipe chilled/hot water operation.

4-Row chilled water / hot water 2-pipe

Four-row slab coil assembly for chilled water only or 2-pipe chilled/hot water operation.

Direct expansion (DX) cooling

Large surface area evaporator coil positioned to optimize heat transfer and airflow. The DX coil includes a TXV for use with R-454B refrigerant. Units with the DX coil will also include (2) A2L leak sensors and safety controls.

Heating option

Hot water/chilled water 2-pipe

- The chilled water coil is used for hot water heating also in a 2-pipe changeover system.

1-Row hot water coil

- One-row hot water heating slab coil assembly.

2-Row hot water coil

- Two-row hot water heating slab coil assembly.

1-Row steam slab coil

- One-row steam heating slab coil assembly.

Coil access

Right hand (RH) and left hand (LH) coil access is available for both heating and cooling coils. For chilled water coils, the standard connection will be on the right hand side of the unit. If left hand cooling connections are required, the factory will bring crossover piping for left hand chilled water connections via the pipe tunnel.

For hot water coils, the standard connection will be on the left hand side of the unit. If right hand heating connections are required, the factory will bring crossover piping for right hand hot water connections via the pipe tunnel.

For DX piping, the standard connections will be on the right hand side of the unit. If left hand DX connections are required, refrigerant piping will be routed to the left side of the unit via the pipe tunnel.

For steam piping, the standard connections are on the left hand side of the unit. If right hand steam connections are required, steam piping will be routed to the right hand side of the unit via the pipe tunnel.

Coil positions

Pre-heat

Heating coil will be positioned in the pre-heat position when cooling is also selected.

Re-heat

Heating coil will be positioned in the re-heat position when cooling is also selected.

Damper assembly (outside air)

Insulated damper

The outside air damper is insulated with 1/2 in. thick insulation to inhibit condensation on the damper surface.

No Damper (Recirculating Unit)

Unit will be recirculating only, with no provision for outside air.

Motor type

EC motor, three-speed switch

The fan motor shall be an electronically commutated motor (ECM). The ECM provides constant torque to compensate for a wide variety of static pressures, up to 0.25 in. wg with the High Static motor. The motor features a brushless, permanently lubricated ball bearing construction for maintenance free operation. The three speed selector switch enables adjustment of the supply air volume. Reduction in fan speed shall be achieved by a step down multi-tap transformer.

EC motor, 0-10 vdc

The fan motor shall be an electronically commutated motor (ECM). The ECM provides constant torque to compensate for a wide variety of static pressures, up to 0.25 in. wg with the High Static motor. The motor features a brushless, permanently lubricated ball bearing construction for maintenance free operation. The supply air volume will be adjusted via a 0-10 vdc signal.

Electrical connections

Left hand side

The electrical connections terminate on the left hand side of the unit. On ceiling mounted units, the electrical connections will always terminate on the left hand side.

Right hand side

The electrical connections terminate on the right hand side of the unit. Due to space constraints, floor mounted units with a cooling piping package will have the mains electrical box containing the disconnect switch, fuses, and other components on the left hand side. A junction box will be installed on the right hand side containing a terminal strip and mains ground lug for the electrical connections.

Controls

By others-field installed

The unit will be provided without a controller or temperature sensors. The controls contractor will be responsible for providing the controller and the appropriate sequence of operations. A wiring diagram will be installed within the unit but will reflect a generic controller.

Direct digital controls (DDC) ready

The unit is provided with a fan relay, 75VA 24-v control circuit transformer, return air, outside air and supply air sensors, disconnect switch, three speed switch, and terminal strip. Damper actuators are included with the DDC Ready package for outside air and face and bypass dampers when included in the unit configuration. All components located in the panel shall be clearly marked for easy identification. All terminal blocks and wires shall be individually numbered. The controls contractor will be responsible for providing the controller and the appropriate sequence of operations. A wiring diagram will be installed within the unit but will reflect a generic controller.

Filtration

70-75% arrestance (standard)

1 in. thick throwaway filter provided and installed at the factory and located to provide filtration of both outdoor and return air prior to being conditioned.

MERV 10

1 in. thick radial pleated disposable filters provided and installed at the factory and located to provide filtration of both outdoor and return air prior to being conditioned.

MERV 13

1 in. thick radial pleated disposable filters provided and installed at the factory and located to provide filtration of both outdoor and return air prior to being conditioned. Minimum Efficiency Reporting Value (MERV) corresponding to the MERV value shown below when evaluated per ASHRAE standard 52.2. Arrestance and Dust Spot Efficiency ratings are based on the ASHRAE 52.2 - 1992 test method.

Piping packages

2-Way valve, all components

Factory assembled and installed piping package includes a 2-way valve, strainer, circuit setter, and shut-off valves.

3-Way valve, all components

Factory assembled and installed piping package includes a 3-way valve, balancing valve, strainer, circuit setter, and shut-off valves.

Piping package components

Modulating control valve

Two-way or three-way modulating valve(s) shall be provided for precise capacity control of hot water and/or chilled water coil(s). The capacity control valve(s) shall be controlled by a 2-10 vdc signal from the unit mounted controller.

2-Position spring return control valve

Two-way or three-way 2-position spring return control valve(s) shall be provided for control of hot water and/or chilled water coil(s). The control valve(s) shall be controlled by a 24-v signal from the units control panel.

Balancing valve

A heavy duty ball-valve construction balancing valve.

Circuit setter

A manually adjustable ball-valve construction balancing valve with Schrader¹ style pressure ports and drain port.

Shut-off valve

A set of two heavy duty ball valves, one for the supply and one for the return.

Strainer

A heavy duty cast iron strainer with screen, gasket and tapped retainer cap and blow-off outlet.

Drain with hose bib

A blowdown valve with hose connector and cap shall be mounted on the coil.

Coil freeze protection

An optional automatic reset freeze protection bulb and capillary tube will be mounted on the discharge side of the first coil to prevent any freezing of the first coil assembly. When the sensor detects a freeze up condition it will force the damper to close off the outside air, force the flow control valve open and prevent the supply fan from running.

Aquastat

An optional aquastat shall be fitted to two-pipe systems to prevent changeover into a heating mode when cooling is required and vice-versa.

Condensate pump

The unit may be fitted with a optional condensate pump. The pump shall be equipped with an ABS plastic tank with built-in flow check valve and safety switch.

Condensate pan float switch

The unit may be fitted with a float switch mounted on the condensate pan to stop the cooling function should the condensate rise to a predetermined level.

Field-installed accessories

Side panels

Factory supplied side panels constructed of 14 gauge sheet steel and painted to match the unit shall be field mounted to the base unit. Side panels are available for both 16-5/8 in. and 21-7/8 in. deep units with or without pipe passage cutouts.

1. Third-party trademarks and logos are the property of their respective owners.

Utility compartment (UV unit only)

A factory supplied utility compartment with 14 gauge sheet steel front and top panels and painted to match the unit shall be field mounted to the base unit. Utility compartments are available for both 16-5/8 in. and 21-7/8 in. deep units in 12 in., 18 in., and 24 in. widths.

Filler section

A factory supplied filler section constructed of 18 gauge sheet steel and painted to match the unit shall be field mounted. Filler sections are available in 6 in., 12 in., and 18 in. widths and can be field cut for custom widths.

Unit sub-base (UV unit only)

Unit height adjustments can be made in increments of 1 in., 2 in., 4 in., and 6 in. with a sub-base field mounted under the standard unit. The sub-base is fully enclosed, constructed of heavy duty steel and painted to match the base of the standard unit.

Utility compartment sub-base

Utility compartment height adjustments can be made in increments of 1 in., 2 in., 4 in., and 6 in. with a sub-base field mounted under the standard utility compartment. The sub-base is fully enclosed, constructed of heavy duty steel and painted to match the base of the standard utility compartment.

Wall sleeve

The wall sleeve shall be constructed from galvanized steel. The sleeve shall be provided by Carrier and insulated by the installing contractor with foil back insulation.

Louver

An outdoor louver shall be furnished by Carrier and be suitable for masonry, glass or panel wall construction. Two louver styles are available: AMCA rated and non-AMCA rated. Louvers shall be made of aluminum with clear anodized finish.

Duct flange

A 1 in. duct flange shall be supplied and field installed to allow for easy installation of a supply air duct to the unit.

Return air kickplate

Factory-supplied floor mounted unit ventilator slotted kickplate accessory shall be supplied and field installed to cover the standard rectangular openings in the unit base.

Component Layout

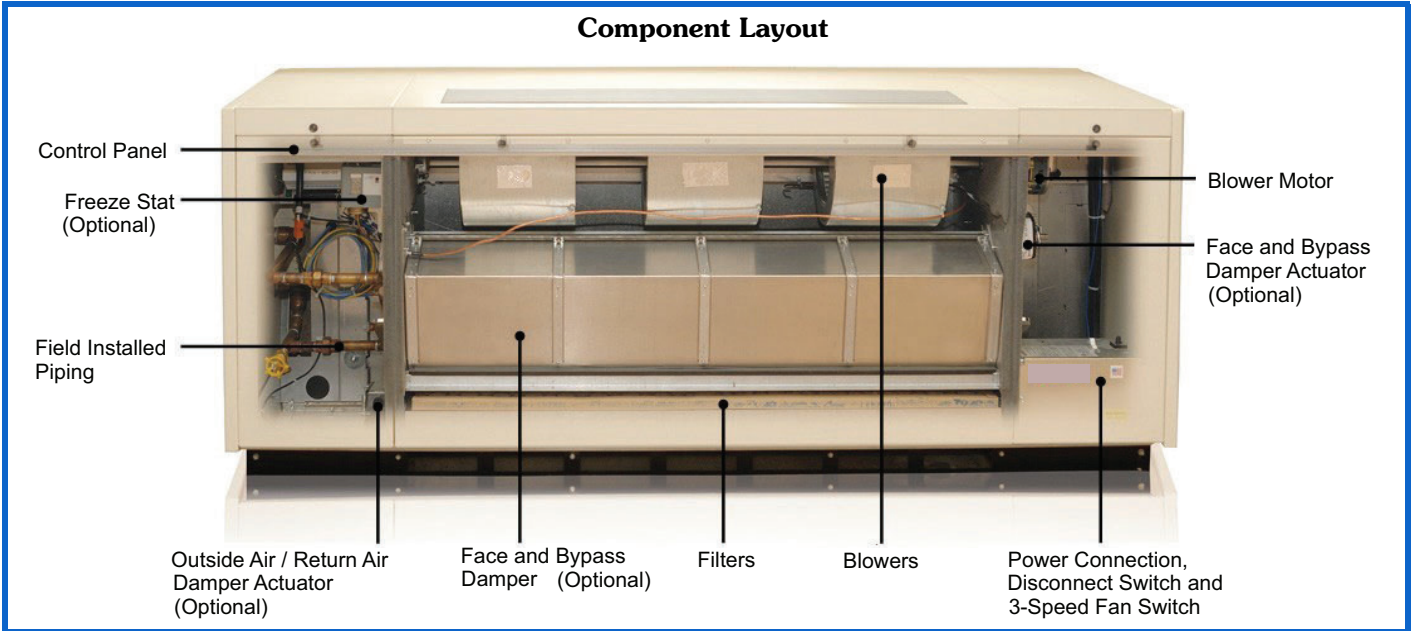

Component Locations

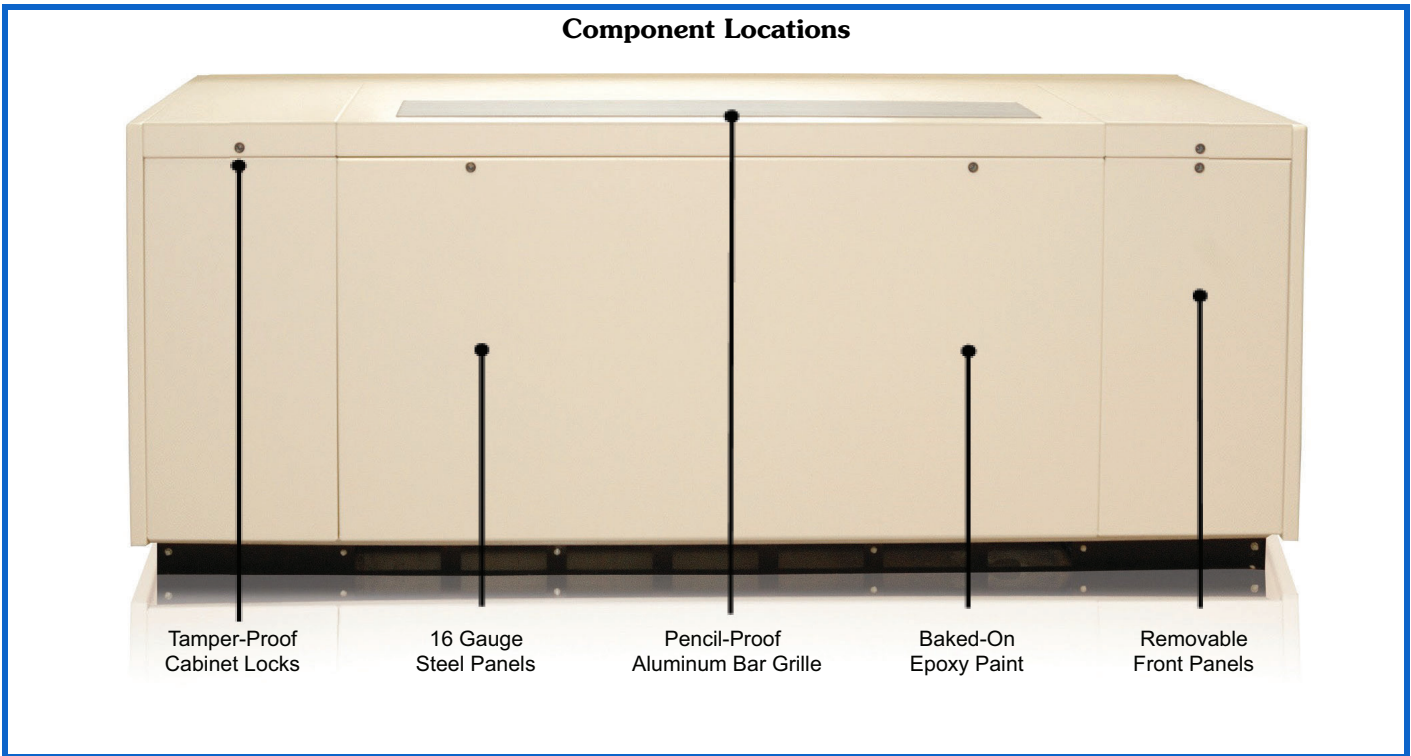

Airflow Arrangements — Inlet Air, Floor Mounted, 16-5/8 in. Depth (Optional 40UV Units)

Rear Outside Air — Open Pipe Tunnel

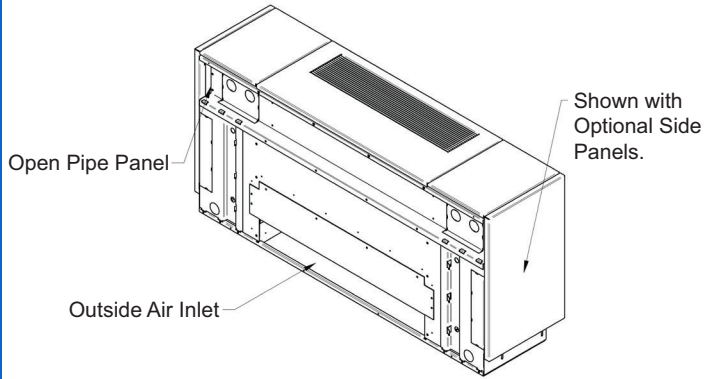

Rear Outside Air — Closed Pipe Tunnel

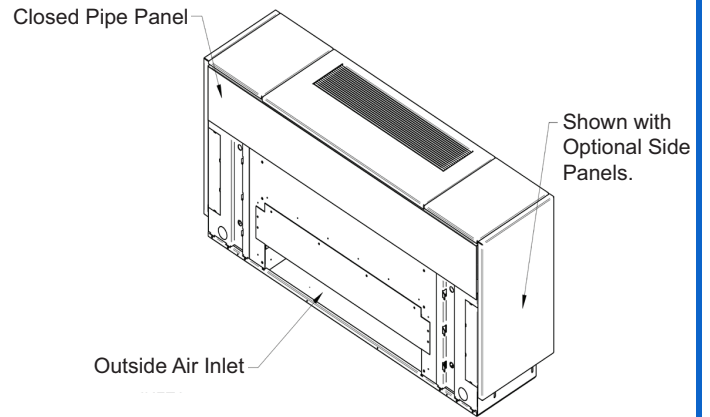

No Outside Air — Open Pipe Tunnel

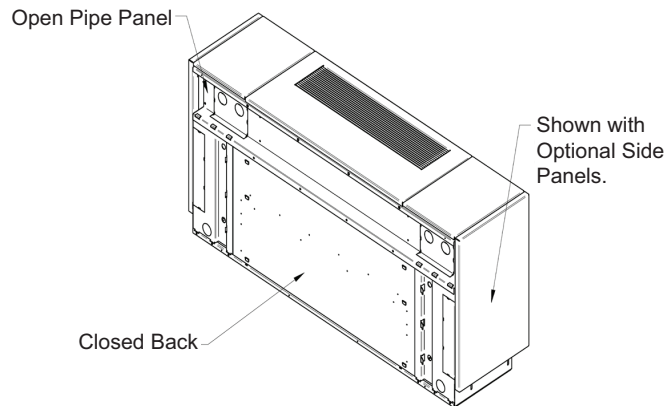

Airflow Arrangements — Inlet Air, Floor Mounted, 21-7/8 in. Depth (Optional 40UV Units)

Rear Outside Air — Open Pipe Tunnel

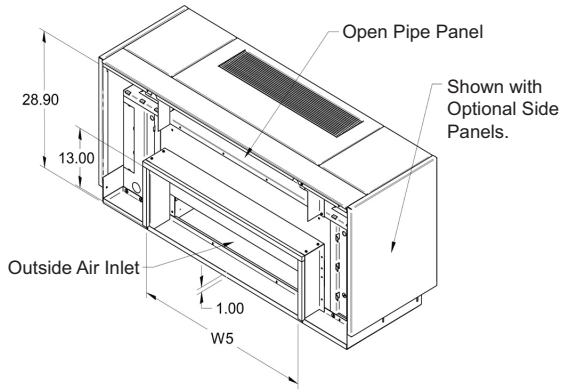

Rear Outside Air — Closed Pipe Tunnel

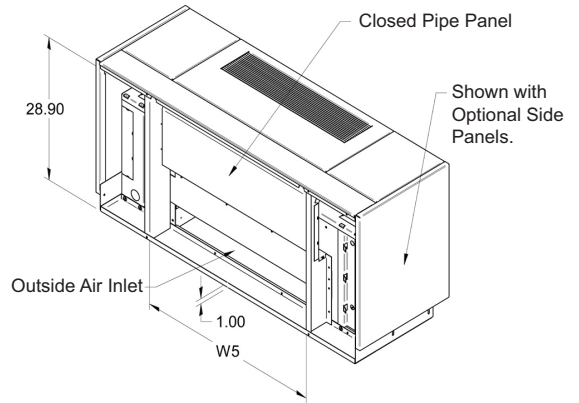

Closed Back — Closed Pipe Tunnel

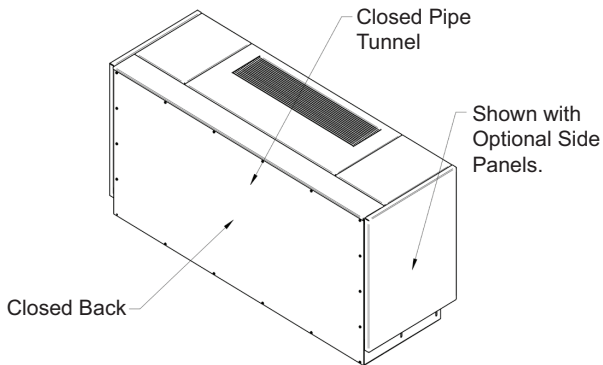

2 in. Step Down — Open Pipe Tunnel

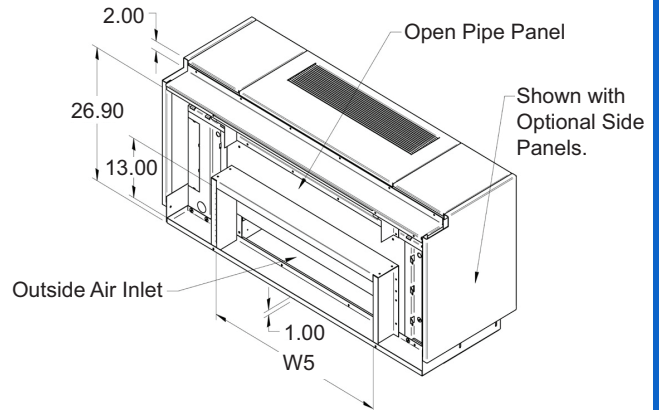

2 in. Step Down — Closed Pipe Tunnel

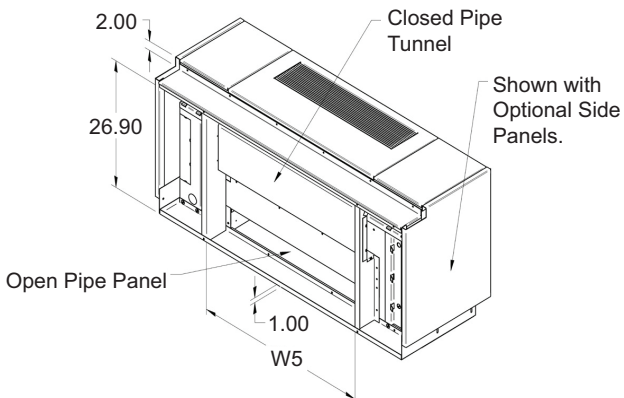

Unit Dimensions

MODEL SIZE	DIMENSIONS (in.)	
	40UV	W5
0750		38
1000		50
1250		62
1500		74

Side Panels — 40UV Floor Mounted Units (16-5/8 or 21-7/8 in.)

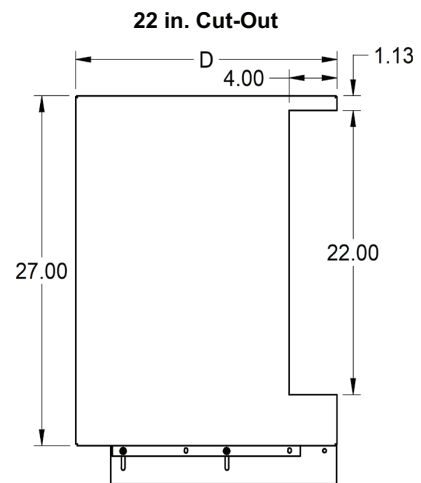
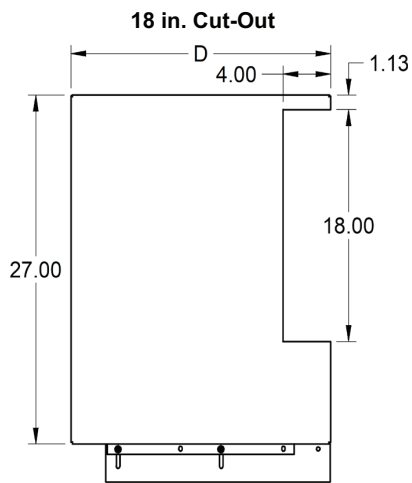
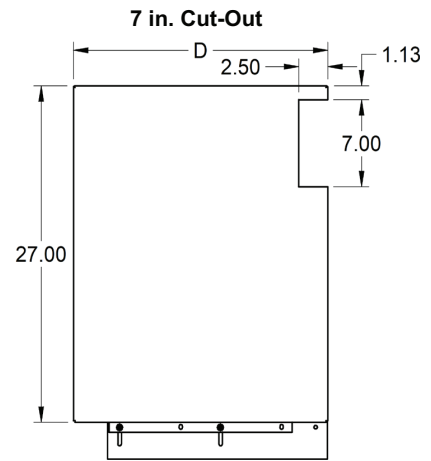
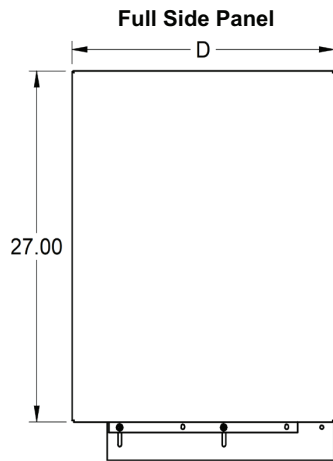

2 in. Step Down (21-7/8 in. Depth Only)

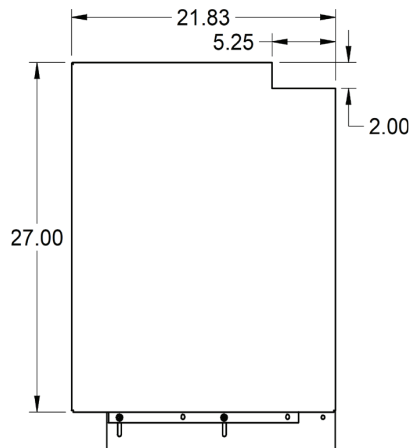

Utility Compartments — 40UV Floor Mounted Units, Flat Top (12, 18, or 24 in.)

16-5/8 in. Flat Top Utility Compartment

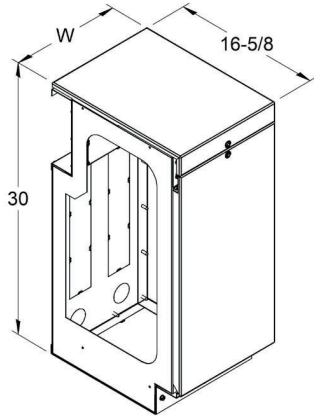

21-7/8 in. Flat Top Utility Compartment

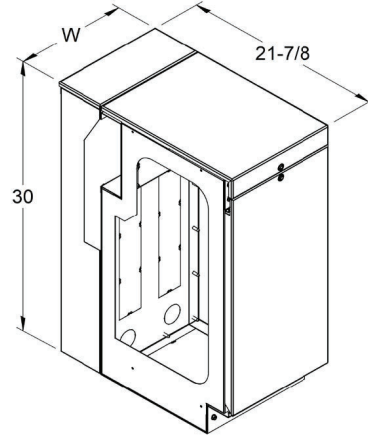

2 in. Step Down Utility Compartment (21-7/8 in. Flat Top Units Only)

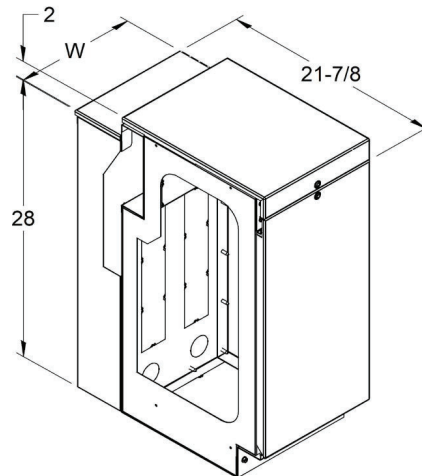

Filler Sections

Flat Top Filler Section for Standard Height Units

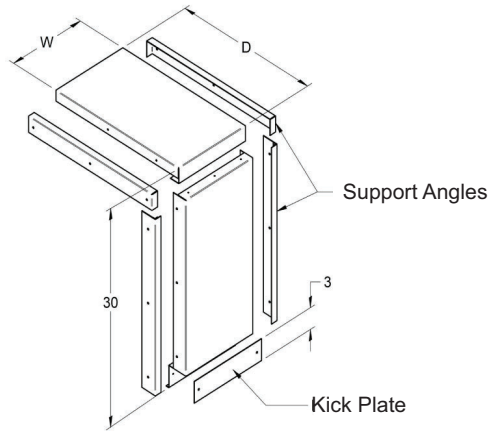

Flat Top Filler Section for Units With Sub-Base

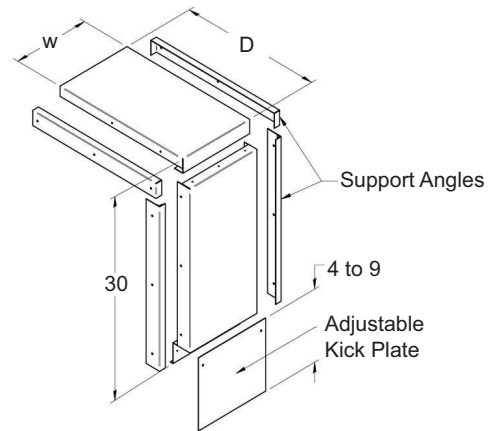

NOTE: W = 6, 12 or 18 in. D = 16-5/8 or 21-7/8 in.

Unit Sub-Base

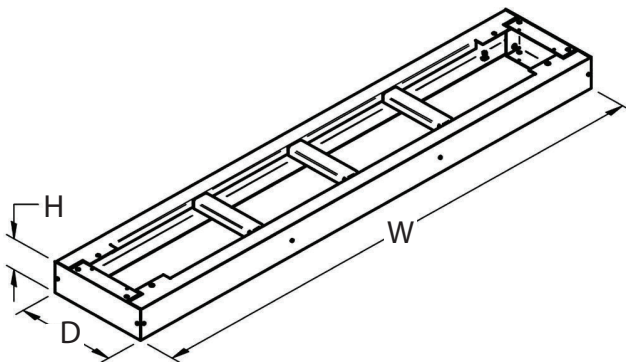

Unit Sub-Base Dimensions

DIMENSIONS (in.)	40UV MODEL SIZE			
	0750	1000	1250	1500
W	62	74	86	98
D (16-5/8 in. Deep Units)	13.65	13.65	13.65	13.65
D (21-7/8 in. Deep Units)	18.90	18.90	18.90	18.90
H	1, 2, 4, or 6 in.			

Wall Sleeve (40UV and 40UH Units) — Field-Installed Kit

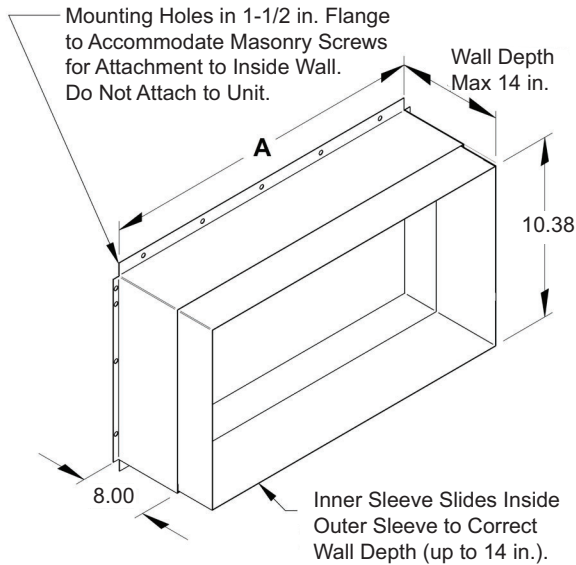

NOTE: Dimensions in inches.

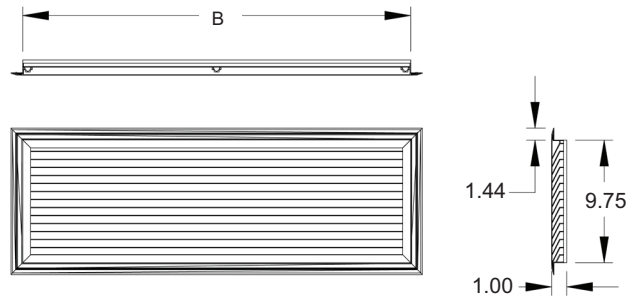

NOTE: Dimensions in inches.

Wall Sleeve and Louver Dimensions

DIMENSIONS (in.)	40UV/UH MODEL SIZE			
	0750	1000	1250	1500
A	36	48	60	72
B	35.5	47.5	59.5	71.5

Return Air Kickplate — Field-Installed Kit

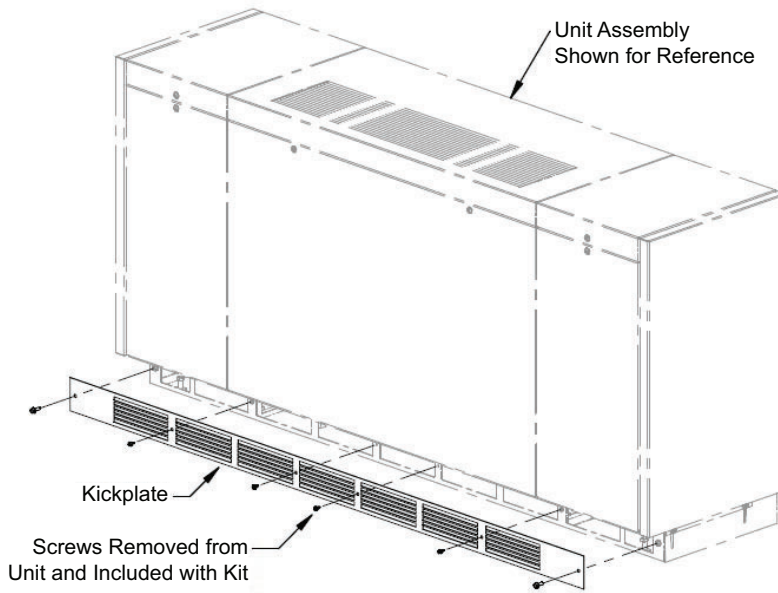

40UV Vertical Unit — 16-5/8 in. Depth — Floor Mounted (Standard)

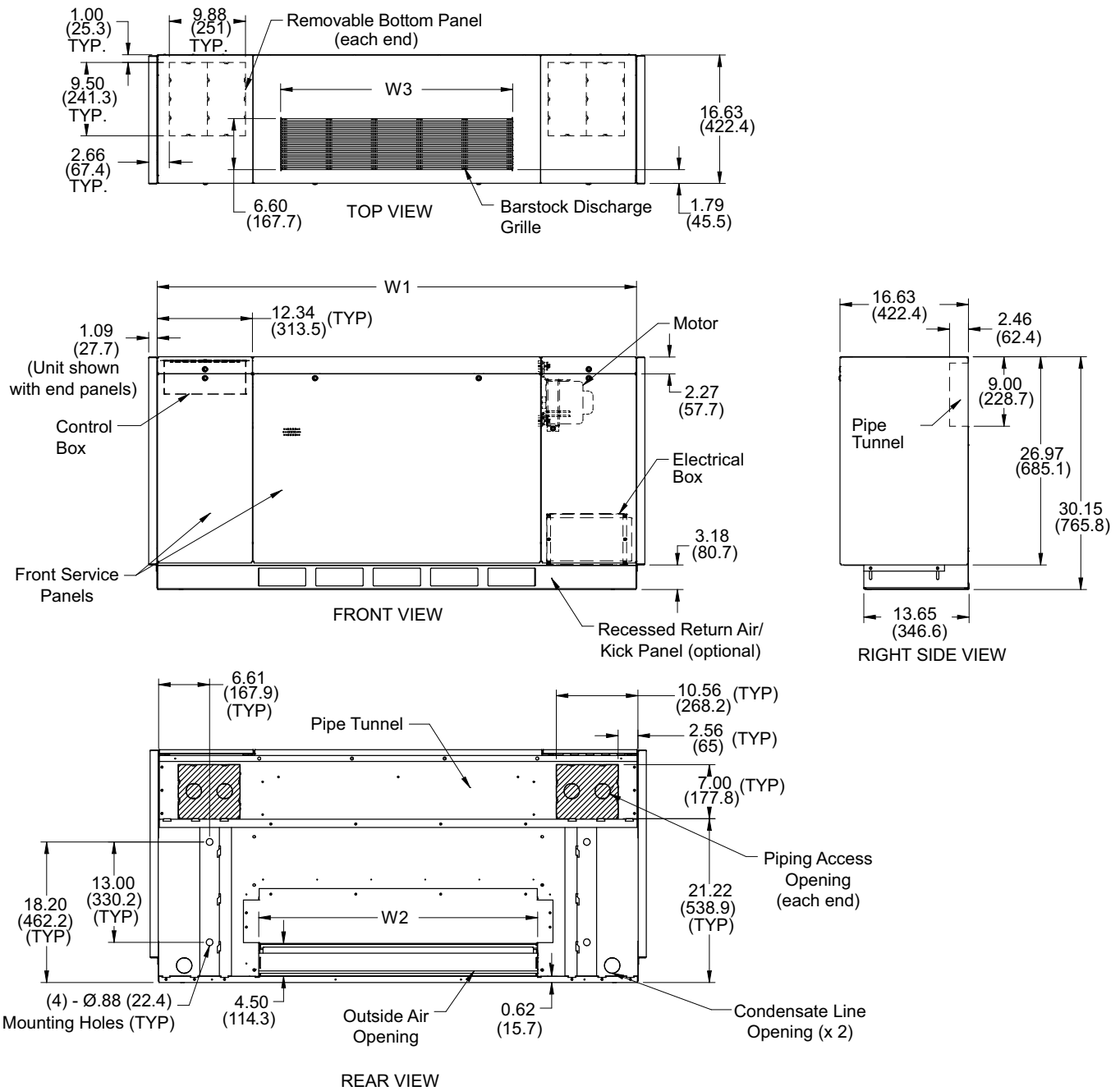

NOTE: Dimensions shown are in inches (mm).

UNIT 40UV	AIRFLOW (cfm)	DIMENSIONS		
		W1	W2	W3
0750	750	62" (1574.8 mm)	36" (914.4 mm)	30" (762.0 mm)
1000	1000	74" (1879.6 mm)	48" (1219.2 mm)	42" (1066.8 mm)
1250	1250	86" (2184.4 mm)	60" (1524.0 mm)	54" (1371.6 mm)
1500	1500	98" (2489.2 mm)	72" (1828.8 mm)	66" (1676.4 mm)

Base unit dimensions (cont)



40UV Vertical Unit — 21-7/8 in. Depth — Floor Mounted (Standard)

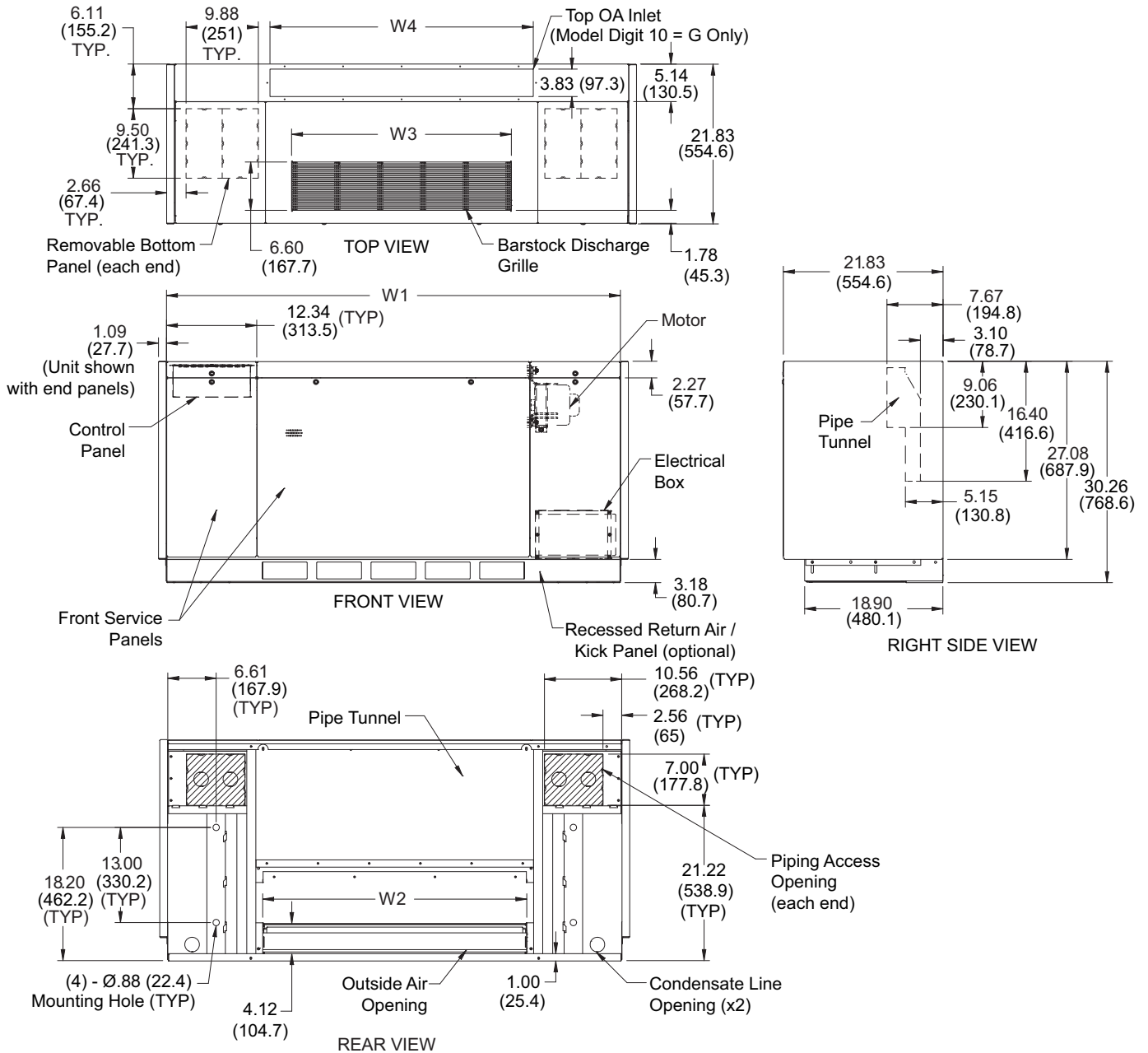

NOTE: Dimensions shown are inches (mm).

UNIT 40UV	AIRFLOW (cfm)	DIMENSIONS			
		W1	W2	W3	W4
0750	750	62" (1574.8 mm)	36" (914.4 mm)	30" (762.0 mm)	36.1" (916.9 mm)
1000	1000	74" (1879.6 mm)	48" (1219.2 mm)	42" (1066.8 mm)	48.1" (1221.7 mm)
1250	1250	86" (2184.4 mm)	60" (1524.0 mm)	54" (1371.6 mm)	60.1" (1526.5 mm)
1500	1500	98" (2489.2 mm)	72" (1828.8 mm)	66" (1676.4 mm)	72.1" (1831.3 mm)

Base unit dimensions (cont)



40UH Horizontal Unit — Ceiling Mounted — Front Discharge

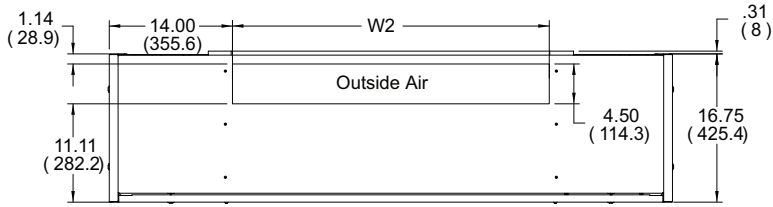

REAR VIEW

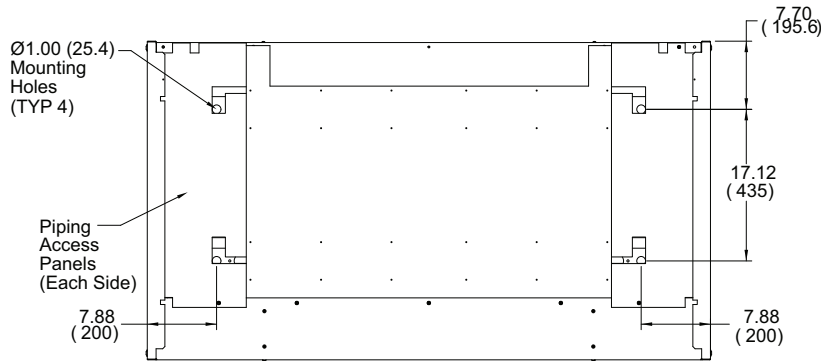

TOP VIEW

LEFT END VIEW

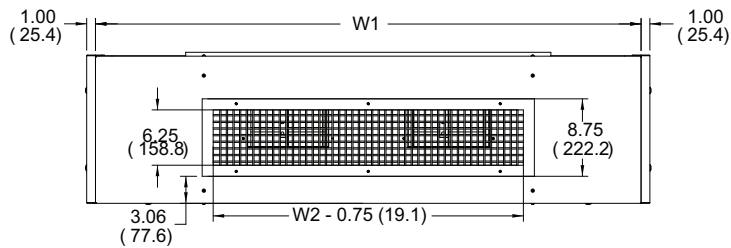
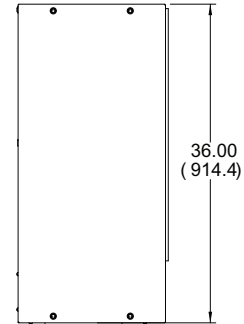

FRONT VIEW

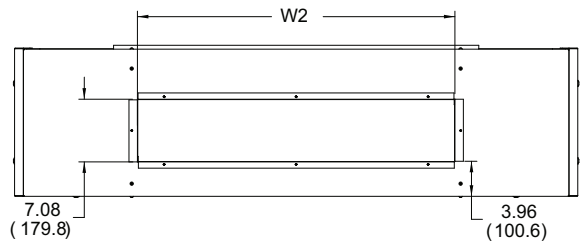

ALT. FRONT VIEW WITH DISCHARGE DUCT COLLAR

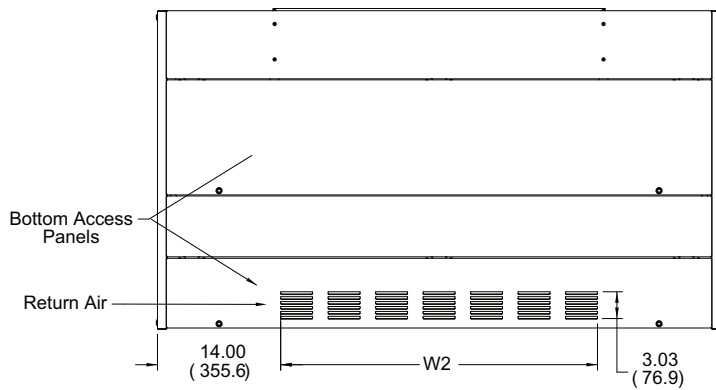

BOTTOM VIEW

UNIT 40UH	AIRFLOW (cfm)	DIMENSIONS (in.)	
		W1	W2
0750	750	62	36
1000	1000	74	48
1250	1250	86	60
1500	1500	98	72

NOTE: Dimensions shown are inches (mm).

Base unit dimensions (cont)



40UH Horizontal Unit — Ceiling Mounted — Down Discharge

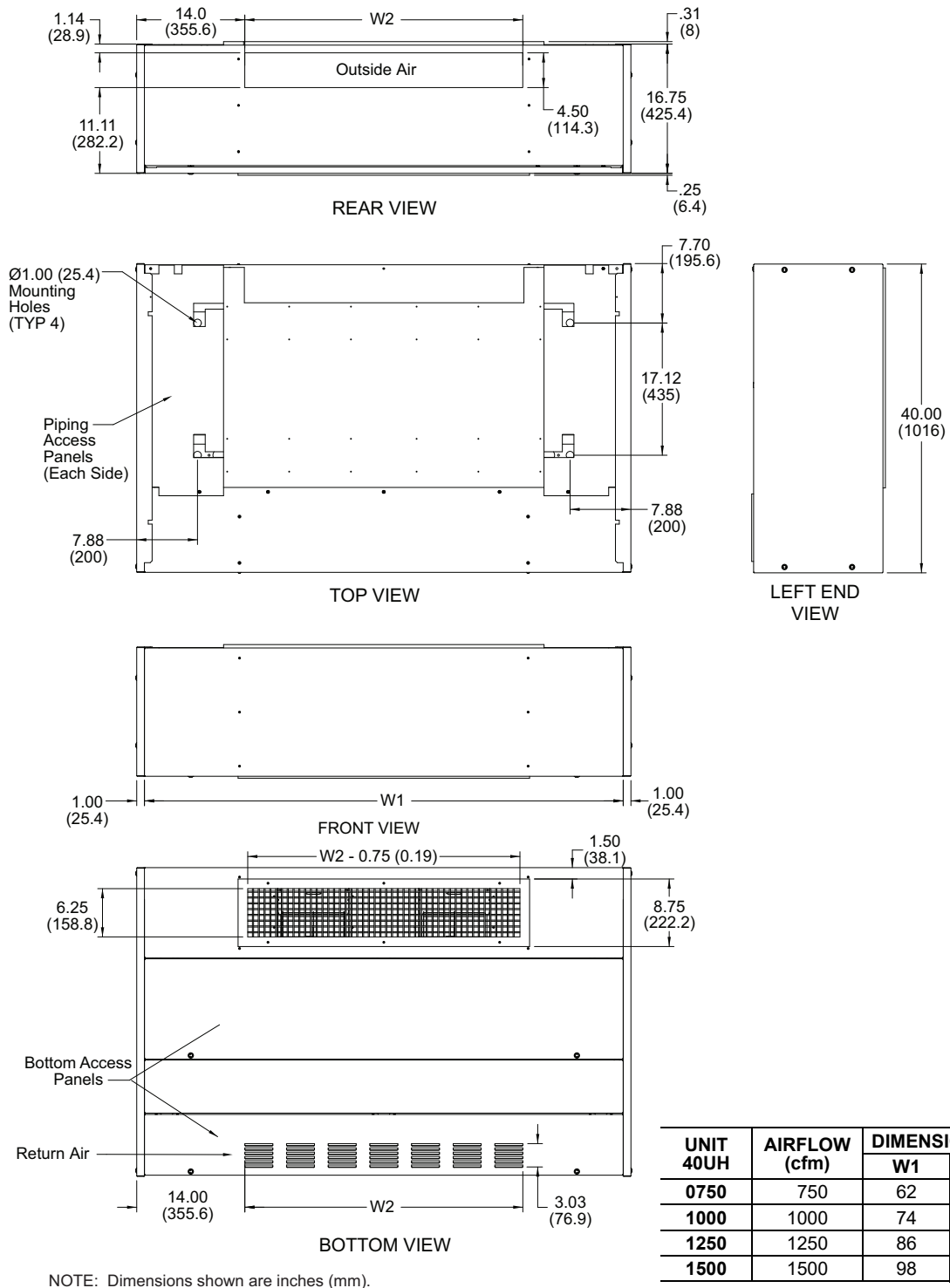

UNIT 40UH	AIRFLOW (cfm)	DIMENSIONS (in.)	
		W1	W2
0750	750	62	36
1000	1000	74	48
1250	1250	86	60
1500	1500	98	72

Chilled Water — Unit Size 0750^{a,b}

40UV, UH UNIT SIZE	EWT (°F)	FLOW RATE (gpm)	NUMBER OF ROWS	PD (PSI)	COOLING CAPACITY AND LEAVING AIR TEMPERATURES				
					Airflow cfm		750 (H)	650 (M)	500 (L)
0750	45	6	2	2.09	TC	Btu/Hr	18,312	17,071	14,694
					SC	Btu/Hr	14,965	13,694	11,464
			LDB	°F	62.0	61.0	59.3		
			LWB	°F	59.5	58.8	57.8		
		4	1.14	TC	Btu/Hr	27,520	25,656	22,083	
				SC	Btu/Hr	19,109	17,486	14,639	
				LDB	°F	57.0	55.8	53.6	
				LWB	°F	55.2	54.2	52.4	
		10	2	5.20	TC	Btu/Hr	21,297	19,255	16,392
					SC	Btu/Hr	16,533	14,908	12,508
			LDB	°F	60.1	59.3	57.5		
			LWB	°F	58.1	57.7	56.6		
4	2.84	TC	Btu/Hr	32,066	28,938	24,634			
		SC	Btu/Hr	21,110	19,036	15,971			
		LDB	°F	54.6	53.6	51.2			
		LWB	°F	53.0	52.3	50.4			

NOTE(S):

- a. Cooling Capacity based on Mixed Air at 80/67°F dry/wet bulb.
- b. For additional capacity information, please consult Carrier.

Chilled Water — Unit Size 1000^{a,b}

40UV, UH UNIT SIZE	EWT (°F)	FLOW RATE (gpm)	NUMBER OF ROWS	PD (PSI)	COOLING CAPACITY AND LEAVING AIR TEMPERATURES				
					Airflow cfm		1000 (H)	750 (M)	600 (L)
1000	45	6	2	2.58	TC	Btu/Hr	27,859	24,376	21,468
					SC	Btu/Hr	22,876	19,163	16,439
			LDB	°F	59.4	57.0	55.3		
			LWB	°F	58.3	56.7	55.3		
		4	1.35	TC	Btu/Hr	34,454	30,147	26,550	
				SC	Btu/Hr	24,461	20,490	17,578	
				LDB	°F	58.0	55.4	53.6	
				LWB	°F	56.0	53.9	52.4	
		10	2	6.40	TC	Btu/Hr	32,099	28,494	25,835
					SC	Btu/Hr	25,955	21,442	19,026
			LDB	°F	56.6	54.2	51.4		
			LWB	°F	56.6	54.2	51.4		
4	3.35	TC	Btu/Hr	39,698	35,240	31,951			
		SC	Btu/Hr	27,752	22,927	20,344			
		LDB	°F	55.0	52.5	49.5			
		LWB	°F	54.1	51.3	48.8			

NOTE(S):

- a. Cooling Capacity based on Mixed Air at 80/67°F dry/wet bulb.
- b. For additional capacity information, please consult Carrier.

LEGEND

- EWT — Entering Water Temperature
- LDB — Leaving Dry Bulb
- LWB — Leaving Wet Bulb
- PD — Pressure Drop
- SC — Sensible Capacity
- TC — Total Capacity

Chilled Water — Unit Size 1250^{a,b}

40UV, UH UNIT SIZE	EWT (°F)	FLOW RATE (gpm)	NUMBER OF ROWS	PD (PSI)	COOLING CAPACITY AND LEAVING AIR TEMPERATURES				
					Airflow cfm		1250 (H)	900 (M)	750(L)
					TC	Btu/Hr			
1250	45	6	2	3.40	TC	Btu/Hr	32,871	28,391	25,135
					SC	Btu/Hr	27,608	22,624	19,635
			LDB	°F	60.1	57.4	56.4		
			LWB	°F	58.8	57.0	56.3		
		4	1.38	TC	Btu/Hr	40,652	35,112	31,085	
				SC	Btu/Hr	29,520	24,191	20,995	
				LDB	°F	58.7	55.8	54.5	
				LWB	°F	56.7	54.4	53.4	
		10	2	8.30	TC	Btu/Hr	39,623	32,737	29,067
					SC	Btu/Hr	30,868	24,748	21,672
			LDB	°F	57.8	55.2	54.0		
			LWB	°F	57.0	55.2	54.0		
4	3.43	TC	Btu/Hr	49,004	40,487	35,949			
		SC	Btu/Hr	33,006	26,462	23,173			
		LDB	°F	56.2	53.5	52.2			
		LWB	°F	54.3	52.1	51.0			

NOTE(S):

- a. Cooling capacity based on mixed air at 80/67°F dry/wet bulb.
- b. For additional capacity information, please consult Carrier.

Chilled Water — Unit Size 1500^{a,b}

40UV, UH UNIT SIZE	EWT (°F)	FLOW RATE (gpm)	NUMBER OF ROWS	PD (PSI)	COOLING CAPACITY AND LEAVING AIR TEMPERATURES				
					Airflow cfm		1500 (H)	1100 (M)	900 (L)
					TC	Btu/Hr			
1500	45	6	2	2.58	TC	Btu/Hr	37,455	32,871	29,721
					SC	Btu/Hr	32,186	26,797	23,503
			LDB	°F	60.7	58.1	56.5		
			LWB	°F	59.3	57.6	56.5		
		4	1.35	TC	Btu/Hr	49,356	40,683	36,784	
				SC	Btu/Hr	34,601	28,808	25,267	
				LDB	°F	59.2	56.4	54.7	
				LWB	°F	57.2	55.1	53.7	
		10	2	6.40	TC	Btu/Hr	45,709	38,736	34,125
					SC	Btu/Hr	36,205	29,616	25,637
			LDB	°F	58.3	55.7	54.3		
			LWB	°F	57.4	55.7	54.3		
4	3.35	TC	Btu/Hr	56,572	47,942	42,235			
		SC	Btu/Hr	38,922	31,839	27,562			
		LDB	°F	56.6	53.9	52.4			
		LWB	°F	54.8	52.6	51.4			

NOTE(S):

- a. Cooling capacity based on mixed air at 80/67°F dry/wet bulb.
- b. For additional capacity information, please consult Carrier.

LEGEND

- EWT** — Entering Water Temperature
- LDB** — Leaving Dry Bulb
- LWB** — Leaving Wet Bulb
- PD** — Pressure Drop
- SC** — Total Capacity
- TC** — Sensible Capacity

Direct Expansion — 40UV, UH Unit Size 0750^a

EVAPORATOR SATURATION TEMPERATURE (°F)	AIRFLOW cfm		750 (H)			650 (M)			500 (L)		
	ENTERING AIR db/wb (°F)		85/71	80/67	75/63	85/71	80/67	75/63	85/71	80/67	75/63
40	TC	Btu/Hr	34,325	28,463	23,036	30,940	25,669	20,786	26,407	21,928	17,782
	SC	Btu/Hr	19,042	16,960	14,849	17,163	15,294	13,396	14,644	13,059	11,451
	LDB	°F	62.1	59.6	57.2	61.2	58.8	56.4	58.6	56.5	54.4
	LWB	°F	57.3	54.8	52.4	56.6	54.2	51.9	54.8	52.6	50.5
45	TC	Btu/Hr	29,630	23,766	18,430	26,724	21,446	16,644	22,829	18,345	14,258
	SC	Btu/Hr	16,780	14,708	12,614	15,132	13,268	11,386	12,918	11,339	9,740
	LDB	°F	64.8	62.3	59.8	64.0	61.6	59.2	61.7	59.6	57.4
	LWB	°F	59.4	57.0	54.7	58.9	56.5	54.3	57.3	55.2	53.2
50	TC	Btu/Hr	24,542	18,802	13,605	22,147	16,981	12,296	18,944	14,547	10,546
	SC	Btu/Hr	14,563	12,510	10,432	13,137	11,291	9,421	11,223	9,657	8,066
	LDB	°F	67.5	65.0	62.5	66.8	64.4	61.9	64.8	62.6	60.5
	LWB	°F	61.6	59.3	57.0	61.2	58.9	56.7	59.9	57.9	56.0

NOTE(S):

a. Performance based on 105°F liquid inlet temperature.

Direct Expansion — 40UV, UH Unit Size 1000^a

EVAPORATOR SATURATION TEMPERATURE (°F)	AIRFLOW cfm		1000 (H)			750 (M)			600 (L)		
	ENTERING AIR db/wb (°F)		85/71	80/67	75/63	85/71	80/67	75/63	85/71	80/67	75/63
40	TC	Btu/Hr	46,343	37,911	30,215	38,144	31,142	24,804	32,848	26,875	21,463
	SC	Btu/Hr	25,801	22,727	19,661	21,237	18,671	16,132	18,291	16,116	13,953
	LDB	°F	61.8	59.5	57.3	59.5	57.6	55.6	57.5	55.8	54.0
	LWB	°F	57.1	54.8	52.6	55.5	53.4	51.5	54.0	52.2	50.4
45	TC	Btu/Hr	39,763	31,423	24,087	32,749	25,860	19,781	28,192	22,328	17,087
	SC	Btu/Hr	22,688	19,649	16,660	18,688	16,160	13,676	16,092	13,946	11,806
	LDB	°F	64.6	62.3	60.0	62.6	60.6	58.6	60.8	59.1	57.3
	LWB	°F	59.3	57.1	54.9	58.0	56.0	54.0	56.8	55.0	53.2
50	TC	Btu/Hr	32,716	24,757	17,677	26,996	20,380	14,494	23,246	17,559	12,483
	SC	Btu/Hr	19,634	16,669	13,698	16,189	13,706	11,232	13,934	11,802	9,675
	LDB	°F	67.3	65.0	62.7	65.6	63.5	61.5	64.1	62.3	60.5
	LWB	°F	61.6	59.4	57.2	60.5	58.6	56.6	59.6	57.8	56.1

NOTE(S):

a. Performance based on 105°F liquid inlet temperature.

LEGEND

LDB — Leaving Dry Bulb
LWB — Leaving Wet Bulb
SC — Total Capacity
TC — Sensible Capacity

Direct Expansion — 40UV, UH Unit Size 1250^a

EVAPORATOR SATURATION TEMPERATURE (°F)	AIRFLOW cfm		1250 (H)			900 (M)			750 (L)		
	ENTERING AIR db/wb (°F)		85/71	80/67	75/63	85/71	80/67	75/63	85/71	80/67	75/63
40	TC	Btu/Hr	62,055	50,784	40,492	49,872	40,756	32,468	43,540	35,633	28,453
	SC	Btu/Hr	34,494	30,368	26,263	27,729	24,385	21,063	24,212	21,326	18,455
	LDB	°F	60.1	58.1	56.1	57.2	55.6	53.9	55.9	54.4	52.8
	LWB	°F	55.9	53.8	51.8	53.8	52.0	50.3	52.8	51.1	49.5
45	TC	Btu/Hr	53,246	42,060	32,261	42,825	33,830	25,876	37,376	29,596	22,633
	SC	Btu/Hr	30,293	26,219	22,226	24,380	21,079	17,834	21,284	18,436	15,600
	LDB	°F	63.2	61.1	59.0	60.6	58.9	57.1	59.4	57.9	56.3
	LWB	°F	58.4	56.3	54.2	56.6	54.9	53.1	55.8	54.2	52.6
50	TC	Btu/Hr	43,777	33,135	23,674	35,296	26,613	18,942	30,791	23,255	16,537
	SC	Btu/Hr	26,181	22,224	18,271	21,096	17,848	14,631	18,405	15,588	12,778
	LDB	°F	66.1	64.0	61.8	63.9	62.1	60.4	62.9	61.3	59.7
	LWB	°F	60.9	58.8	56.7	59.5	57.7	56.0	58.9	57.2	55.6

NOTE(S):

a. Performance based on 105°F liquid inlet temperature.

Direct Expansion — 40UV, UH Unit Size 1500^a

EVAPORATOR SATURATION TEMPERATURE (°F)	AIRFLOW cfm		1500 (H)			1100 (M)			900 (L)		
	ENTERING AIR db/wb (°F)		85/71	80/67	75/63	85/71	80/67	75/63	85/71	80/67	75/63
40	TC	Btu/Hr	71,293	58,404	46,636	57,981	47,427	37,803	50,287	41,211	32,891
	SC	Btu/Hr	39,581	34,844	30,138	32,198	28,311	24,452	27,930	24,610	21,290
	LDB	°F	61.2	59.1	56.9	58.6	56.8	55.0	57.0	55.4	53.7
	LWB	°F	56.7	54.4	52.3	54.8	52.8	51.0	53.6	51.8	50.1
45	TC	Btu/Hr	61,240	48,405	37,142	49,855	39,329	30,174	43,229	34,188	26,276
	SC	Btu/Hr	34,743	30,066	25,490	28,303	24,455	20,712	24,552	21,257	18,037
	LDB	°F	64.1	61.9	59.7	61.8	60.0	58.0	60.4	58.7	56.9
	LWB	°F	59.0	56.8	54.6	57.4	55.6	53.6	56.5	54.7	53.0
50	TC	Btu/Hr	50,283	38,162	27,273	41,040	31,073	22,195	35,610	27,006	19,326
	SC	Btu/Hr	29,992	25,478	20,972	24,471	20,749	17,051	21,229	18,034	14,838
	LDB	°F	67.0	64.7	62.4	65.0	63.0	61.0	63.7	61.9	60.1
	LWB	°F	61.3	59.1	57.0	60.1	58.2	56.3	59.4	57.6	55.8

NOTE(S):

a. Performance based on 105°F liquid inlet temperature.

LEGEND

LDB — Leaving Dry Bulb
LWB — Leaving Wet Bulb
SC — Total Capacity
TC — Sensible Capacity

Hot Water Heating — Unit Size 0750^{a,b}

40UV,UH UNIT SIZE	EWT (°F)	FLOW RATE (GPM)	NUMBER OF ROWS	PD (PSI)	COOLING CAPACITY AND LEAVING AIR TEMPERATURES				
					Airflow cfm		750 (H)	650 (M)	500 (L)
					TC	Btu/Hr	°F		
0750	160	6	1	0.88	TC	Btu/Hr	38,386	34,752	28,560
					LAT	°F	106.4	108.5	111.8
			2	1.78	TC	Btu/Hr	50,110	45,366	37,283
					LAT	°F	120.6	123.3	127.7
			4 ^c	0.86	TC	Btu/Hr	61,152	55,363	45,499
					LAT	°F	134.0	137.3	142.6
		10	1	2.32	TC	Btu/Hr	41,823	37,438	30,477
					LAT	°F	110.6	112.3	115.3
			2	4.71	TC	Btu/Hr	54,596	48,872	39,786
					LAT	°F	126.1	128.2	132.2
			4 ^c	2.28	TC	Btu/Hr	66,627	59,642	48,553
					LAT	°F	140.6	143.3	148.1

NOTE(S):

- a. Performance based on mixed air at 60°F dry bulb.
- b. For additional capacity information, please consult Carrier.
- c. 2-pipe chilled water / hot water units.

Hot Water Heating — Unit Size 1000^{a,b}

40UV, UH UNIT SIZE	EWT (°F)	FLOW RATE (GPM)	NUMBER OF ROWS	PD (PSI)	COOLING CAPACITY AND LEAVING AIR TEMPERATURES				
					Airflow cfm		1000 (H)	750 (M)	600 (L)
					TC	Btu/Hr	°F		
1000	160	6	1	1.16	TC	Btu/Hr	49,804	40,803	34,395
					LAT	°F	105.2	109.4	112.0
			2	2.35	TC	Btu/Hr	62,381	51,107	43,080
					LAT	°F	116.6	121.8	125.2
			4 ^c	1.14	TC	Btu/Hr	81,135	66,472	56,032
					LAT	°F	133.6	140.4	144.7
		10	1	3.07	TC	Btu/Hr	54,685	44,005	36,773
					LAT	°F	109.6	113.2	115.6
			2	6.20	TC	Btu/Hr	68,494	55,118	46,059
					LAT	°F	122.2	126.7	129.7
			4 ^c	3.01	TC	Btu/Hr	89,086	71,689	59,906
					LAT	°F	140.8	146.7	150.6

NOTE(S):

- a. Performance based on mixed air at 60°F dry bulb.
- b. For additional capacity information, please consult Carrier.
- c. 2-pipe chilled water / hot water units.

LEGEND

- EWT — Entering Air Temperature
- LAT — Leaving Air Temperature
- PD — Pressure Drop
- TC — Total Capacity

Performance data (cont)



Hot Water Heating — Unit Size 1250^{a,b}

40UV, UH UNIT SIZE	EWT (°F)	FLOW RATE (GPM)	NUMBER OF ROWS	PD (PSI)	COOLING CAPACITY AND LEAVING AIR TEMPERATURES				
					Airflow cfm		1250 (H)	900 (M)	750 (L)
1250	160	6	1	1.45	TC	Btu/Hr	59,656	47,744	41,610
					LAT	°F	103.3	108.1	110.3
			2	2.93	TC	Btu/Hr	77,550	62,065	54,091
					LAT	°F	116.3	122.6	125.5
			4 ^c	1.43	TC	Btu/Hr	99,226	79,413	69,210
					LAT	°F	132.0	140.1	143.7
		10	1	3.82	TC	Btu/Hr	66,035	51,738	44,724
					LAT	°F	107.9	112.2	114.1
			2	7.71	TC	Btu/Hr	85,843	67,258	58,139
					LAT	°F	122.3	127.8	130.3
			4 ^c	3.75	TC	Btu/Hr	109,836	86,057	74,389
					LAT	°F	139.7	146.8	150.0

NOTE(S):

- a. Performance based on mixed air at 60°F dry bulb.
- b. For additional capacity information, please consult Carrier.
- c. 2-pipe chilled water / hot water units.

Hot Water Heating — Unit Size 1500^{a,b}

40UV, UH UNIT SIZE	EWT (°F)	FLOW RATE (GPM)	NUMBER OF ROWS	PD (PSI)	COOLING CAPACITY AND LEAVING AIR TEMPERATURES				
					Airflow cfm		1500 (H)	1100 (M)	900 (L)
1500	160	6	1	1.75	TC	Btu/Hr	70,109	57,236	49,403
					LAT	°F	102.4	107.2	109.8
			2	3.52	TC	Btu/Hr	92,625	75,619	65,269
					LAT	°F	116.0	122.4	125.8
			4 ^c	1.71	TC	Btu/Hr	108,959	88,594	76,779
					LAT	°F	125,978	133.4	137.4
		10	1	4.58	TC	Btu/Hr	78,277	62,508	53,391
					LAT	°F	107.4	111.6	113.8
			2	9.24	TC	Btu/Hr	103,417	82,584	70,539
					LAT	°F	122.6	128.1	131.1
			4 ^c	4.49	TC	Btu/Hr	121,653	97,146	82,978
					LAT	°F	133.6	140.1	143.7

NOTE(S):

- a. Performance based on mixed air at 60°F dry bulb.
- b. For additional capacity information, please consult Carrier.
- c. 2-pipe chilled water / hot water units.

LEGEND

- EWT** — Entering Air Temperature
- LAT** — Leaving Air Temperature
- PD** — Pressure Drop
- TC** — Total Capacity

40UV, UH Steam Heating Capacity at 2 lb Steam^a

UNIT SIZE	AIRFLOW cfm	AIR ON COIL TEMPERATURE (°F)									
		40		50		60		70		80	
		TC (MBH)	LAT (°F)	TC (MBH)	LAT (°F)	TC (MBH)	LAT (°F)	TC (MBH)	LAT (°F)	TC (MBH)	LAT (°F)
750	750 (H)	59.9	113.9	56.1	119.3	52.3	124.5	48.7	130.1	44.9	135.4
	650 (M)	54.8	118.1	51.4	123.2	47.9	128.2	44.5	133.5	41.1	138.6
	500 (L)	45.7	124.7	42.9	129.4	39.9	133.9	37.2	138.8	34.3	143.5
1000	1000 (H)	84.4	118.1	79.1	123.2	73.7	128.2	68.6	133.5	63.3	138.6
	750 (M)	63.3	118.1	59.3	123.2	55.2	128.2	51.4	133.5	47.4	138.6
	600 (L)	54.0	123.4	50.6	128.1	47.2	132.8	43.9	137.7	40.5	142.5
1250	1250 (H)	97.0	111.9	90.9	117.3	84.7	122.7	78.8	128.4	72.7	133.9
	900 (M)	74.3	116.4	69.6	121.6	64.8	126.7	60.3	132.1	55.7	137.3
	750 (L)	66.3	121.9	62.1	126.7	57.9	131.5	53.9	136.5	49.7	141.4
1500	1500 (H)	116.9	112.2	109.6	117.6	102.0	123.0	95.0	128.6	87.6	134.1
	1100 (M)	89.1	115.0	83.5	120.3	77.8	125.5	72.4	130.9	66.8	136.2
	900 (L)	80.5	122.8	75.5	127.6	70.3	132.3	65.4	137.3	60.4	142.1

NOTE(S):

a. Steam heating performance based on 2 psig steam.

40UV, UH Steam Heating and Leaving Air Temperature Correction Factors

STEAM PRESSURE (psig)	AIR ON COIL TEMPERATURE (°F)									
	40		50		60		70		80	
	TC (MBH)	LAT (°F)	TC (MBH)	LAT (°F)	TC (MBH)	LAT (°F)	TC (MBH)	LAT (°F)	TC (MBH)	LAT (°F)
0	0.96	0.96	0.96	0.97	0.96	0.96	0.96	0.95	0.97	0.93
2	1.00	1.00	1.00	1.00	1.00	1.00	1.00	1.00	1.00	1.00
5	1.04	1.05	1.05	1.05	1.05	1.06	1.05	1.06	1.06	1.07
10	1.10	1.12	1.11	1.13	1.12	1.14	1.13	1.15	1.14	1.15

LEGEND

LAT — Leaving Air Temperature
 TC — Total Capacity

40UV, UH — Electrical Data

UNIT	NOMINAL V/Ph/Hz	CONDENSATE PUMP	FLA	MCA	MOP
STANDARD – ECM	115/1/60	No	5.7	7.1	15
		Yes	7.2	8.6	15
	208/1/60	No	3.8	4.7	15
		Yes	4.4	5.3	15
	230/1/60	No	3.3	4.1	15
		Yes	3.8	4.6	15
277/1/60	No	3.5	4.4	15	
	Yes	4.0	4.9	15	
HIGH STATIC – ECM	115/1/60	No	6.8	8.5	15
		Yes	8.3	10.0	15
	208/1/60	No	4.5	5.6	15
		Yes	5.1	6.2	15
	230/1/60	No	4.1	5.1	15
		Yes	4.6	5.6	15
277/1/60	No	3.7	4.6	15	
	Yes	4.2	5.1	15	

LEGEND

- ECM** — Electronically Communicated Motor
- FLA** — Full Load Amps
- MCA** — Unit Minimum Circuit Ampacity
- MOP** — Maximum Overcurrent Protection (Maximum Fuse Size or Circuit Breaker Amps)

Piping components

- modulating control valve/2-way or 3-way (for valve control units)
- 2-position control valve/2-way or 3-way (for face and bypass units)
- balancing valve
- circuit setter
- drain with hose bib
- shut off valves
- strainer

Piping components are factory assembled and shipped installed to the unit.

Piping components shipped installed to the unit are 3/4 in. for chilled water and 1/2 in. for hot water.

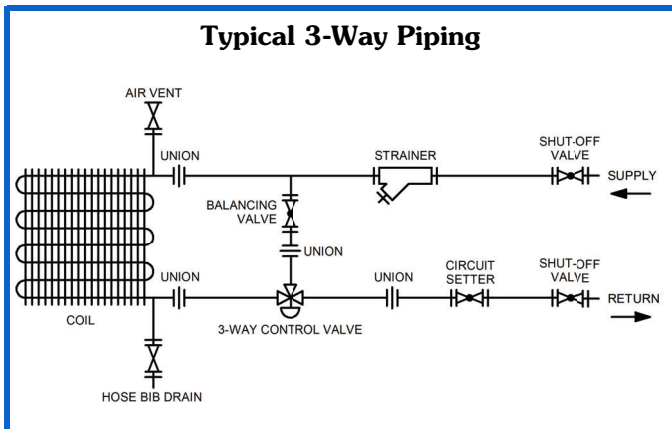
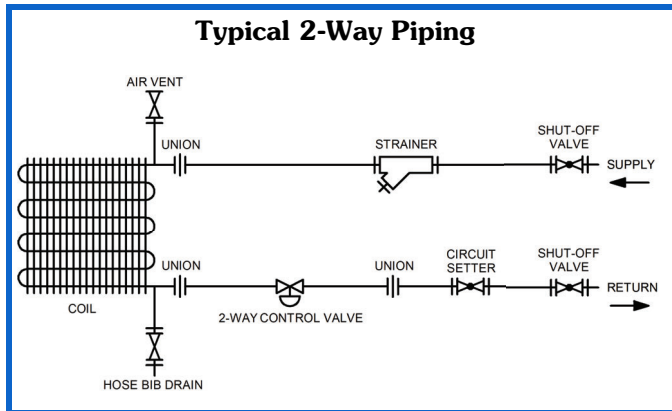

Cooling piping connection locations — floor units (no piping package)

Chilled water

Chilled Water Coil With Or Without Optional Re-Heat Coil

LEFT HAND CONNECTIONS

RIGHT HAND CONNECTIONS

S = Supply
R = Return

NOTES:

1. Supply and Return connection locations represent counterflow orientation (recommended). Unit should be piped in accordance with good plumbing practices.
2. All dimensions shown are in inches and are for reference only. For dimensions in mm, multiply inches by 25.4.

**Piping Location Dimensions
(Chilled Water Optional Re-heat Coil)^{a,b}**

UNIT DEPT	COIL ROWS	DIMENSIONS (in.)							
		A	B	C	D	E	F	G	H
16-5/8	2-row	14.25	11.25	7.25	4.75	13.50	12.25	8.25	4.00
	4-row	15.00	11.00	7.50	4.75	14.00	11.75	9.50	3.00
21-7/8	2-row	14.25	16.50	7.25	10.00	13.50	17.50	8.25	10.00
	4-row	15.00	16.25	7.50	10.00	14.00	17.00	9.50	8.25

NOTE(S):

- a. For hot water re-heat piping locations see "Hot Water Re-Heat Coil with Chilled Water/DX Cooling Coil (No Piping Package)" on page 31.
- b. For steam re-heat piping locations see "Steam Re-Heat Coil With Chilled Water/DX Cooling Coil (No Piping Package)" on page 32.

Chilled Water Coil with Pre-Heat Coil (No Piping Package)

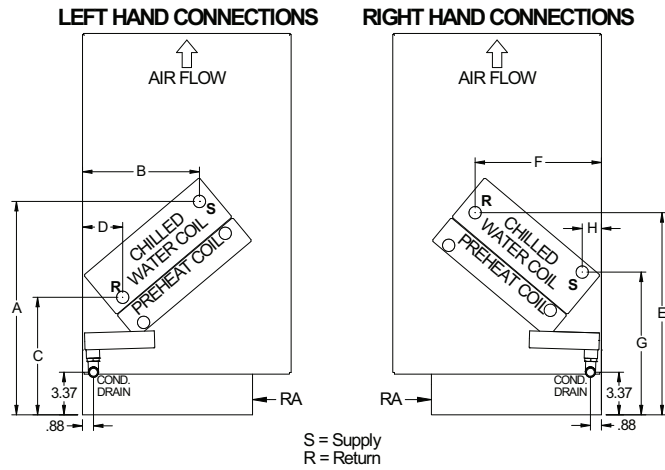

NOTES:

1. Supply and Return connection locations represent counterflow orientation (recommended). Unit should be piped in accordance with good plumbing practices.
2. All dimensions shown are in inches and are for reference only. For dimensions in mm, multiply inches by 25.4.

Piping Location Dimensions (Chilled Water Pre-Heat Coil)^{a,b}

UNIT DEPTH (in.)	COIL ROWS	DIMENSIONS (in.)							
		A	B	C	D	E	F	G	H
16-5/8	2-row	17.50	8.75	10.50	2.25	16.50	9.50	11.50	1.50
	4-row	16.75	9.25	9.25	3.25	16.00	10.00	11.25	1.50
21-7/8	2-row	17.50	14.00	10.50	7.50	16.50	14.75	11.50	6.75
	4-row	16.75	14.50	9.25	8.50	16.00	15.25	11.25	6.75

NOTE(S):

- a. For hot water pre-heat piping locations see "Hot Water Only or Chilled Water/DX Cooling Coil with Hot Water Pre-Heat Coil (No Piping Package)" on page 31.
- b. For steam pre-heat piping locations see "Steam Heating Coil Only or Chilled Water/DX Cooling Coil With Steam Pre-Heat Coil" on page 32.

Direct expansion (DX) coil connection locations — 40UV, Size 0750 only

DX Cooling (Size 0750) With or Without Optional Re-Heat Coil

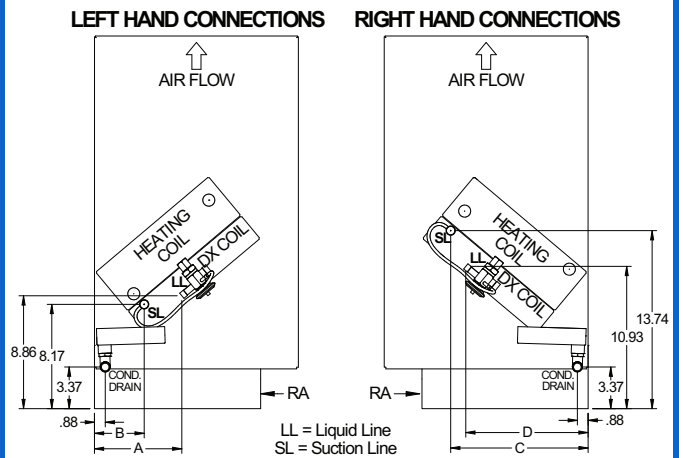

DX Cooling (Size 0750) with Pre-Heat Coil

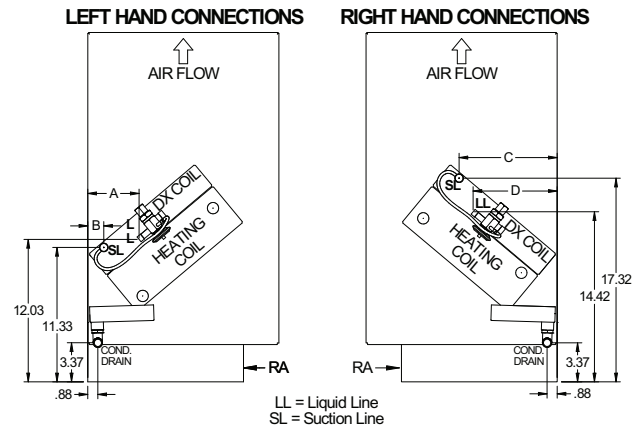

DX Cooling Coil Piping Locations^{a,b}

UNIT DEPT	MODEL SIZE	DIMENSIONS			
		A	B	C	D
16-5/8	0750	14.25	11.25	7.25	4.75
21-7/8	0750	14.25	16.50	7.25	10.00

NOTE(S):

- a. For hot water re-heat piping location see "Hot Water Re-Heat Coil with Chilled Water/DX Cooling Coil (No Piping Package)" on page 31. For steam re-heat piping location see "Steam Re-Heat Coil With Chilled Water/DX Cooling Coil (No Piping Package)" on page 32.
- b. For hot water pre-heat piping location see "Hot Water Only or Chilled Water/DX Cooling Coil with Hot Water Pre-Heat Coil (No Piping Package)" on page 31. For steam pre-heat piping location see "Steam Heating Coil Only or Chilled Water/DX Cooling Coil With Steam Pre-Heat Coil" on page 32.

40UV heating piping connection locations — (no piping package)

Hot water heating coil

Hot Water Only or Chilled Water/DX Cooling Coil with Hot Water Pre-Heat Coil (No Piping Package)

LEFT HAND CONNECTIONS

RIGHT HAND CONNECTIONS

S = Supply
R = Return

NOTES:

- Supply and Return connection locations represent counterflow orientation (recommended). Unit should be piped in accordance with good plumbing practices. Refer to Hot Water Heating Coil Piping Locations table dimensions.
- All dimensions shown are in inches and are for reference only. For dimensions in mm, multiply inches by 25.4.

Hot Water Heating Coil Piping Locations^a

UNIT DEPTH (in.)	COIL ROW	DIMENSIONS (in.)							
		A	B	C	D	E	F	G	H
16-5/8	1-row	14.25	11.50	7.00	5.00	13.50	12.00	8.25	4.00
	2-row	14.25	11.25	7.25	4.75	13.50	12.25	8.25	4.00
21-7/8	1-row	14.25	16.75	7.00	10.25	13.50	17.25	8.25	9.25
	2-row	14.25	16.50	7.25	10.00	13.50	17.50	8.25	9.25

NOTE(S):

a. For Chilled Water piping location see "Chilled Water Coil With Or Without Optional Re-Heat Coil" on page 28. For DX Cooling piping location see "DX Cooling (Size 0750) with Pre-Heat Coil" on page 29. "DX Cooling (Size 1000-1500) with Pre-Heat Coil" on page 30.

Hot Water Re-Heat Coil with Chilled Water/DX Cooling Coil (No Piping Package)

LEFT HAND CONNECTIONS

RIGHT HAND CONNECTIONS

S = Supply
R = Return

NOTES:

- Supply and Return connection locations represent counterflow orientation (recommended). Unit should be piped in accordance with good plumbing practices. Refer to Hot Water Re-Heat Coil Piping Locations table dimensions.
- All dimensions shown are in inches and are for reference only. For dimensions in mm, multiply inches by 25.4.

Hot Water Heating Coil Piping Locations^a

UNIT DEPTH (in.)	COIL ROW	DIMENSIONS (in.)							
		A	B	C	D	E	F	G	H
16-5/8	1-row	14.25	11.50	7.00	5.00	13.50	12.00	8.25	4.00
	2-row	14.25	11.25	7.25	4.75	13.50	12.25	8.25	4.00
21-7/8	1-row	14.25	16.75	7.00	10.25	13.50	17.25	8.25	9.25
	2-row	14.25	16.50	7.25	10.00	13.50	17.50	8.25	9.25

NOTE(S):

a. For Chilled Water piping location see "Chilled Water Coil With Or Without Optional Re-Heat Coil" on page 28. For DX Cooling piping location see "DX Cooling (Size 0750) With or Without Optional Re-Heat Coil" on page 29 and "DX Cooling (Size 1000-1500) with or without Optional Re-Heat Coil" on page 30.

Application data (cont)



Steam heating coil piping connection locations — 40UV

Steam Heating Coil Only or Chilled Water/DX Cooling Coil With Steam Pre-Heat Coil (No Piping Package)

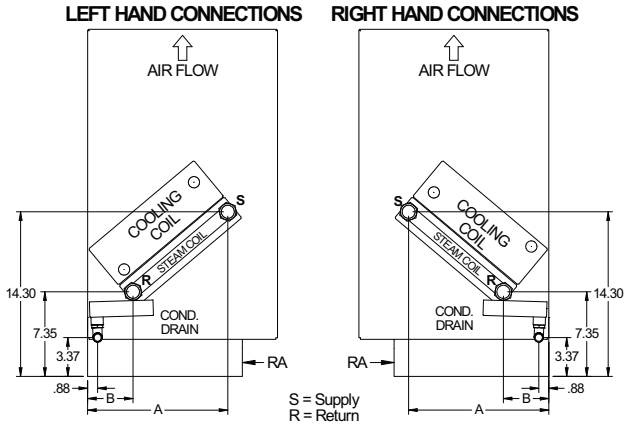

Steam Heating Coil Piping Locations^a

UNIT DEPTH (in.)	COIL ROW	DIMENSIONS (in.)	
		A	B
16-5/8	1-Row	12.25	4.00
21-7/8	1-Row	17.50	9.25

NOTE(S):

- a. For Chilled Water piping location see "Chilled Water Coil with Pre-Heat Coil (No Piping Package)" on page 29. For DX Cooling piping location see "DX Cooling (Size 0750) with Pre-Heat Coil" on page 29 and "DX Cooling (Size 1000-1500) with Pre-Heat Coil" on page 30.

Steam Re-Heat Coil With Chilled Water/DX Cooling Coil (No Piping Package)

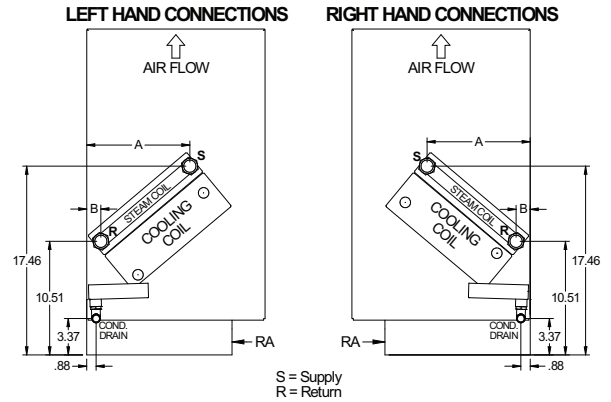

Steam Re-Heat Coil Piping Locations^a

UNIT DEPTH (in.)	COIL ROW	DIMENSIONS (in.)	
		A	B
16-5/8	1-Row	9.50	1.25
21-7/8	1-Row	14.75	6.50

NOTE(S):

- a. For Chilled Water piping location see "Chilled Water Coil With Or Without Optional Re-Heat Coil" on page 28. For DX Cooling piping location see "DX Cooling (Size 0750) With or Without Optional Re-Heat Coil" on page 29 and "DX Cooling (Size 1000-1500) with Pre-Heat Coil" on page 30.

40UV cooling piping connection locations — floor units (with piping package)

Chilled water

Chilled Water Coil With or Without Optional Re-Heat Coil (With Piping Package)

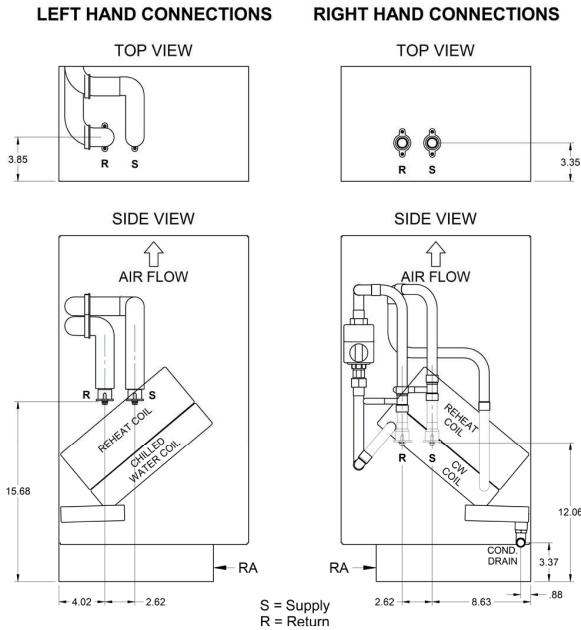

- NOTE(S):
1. Condensate drain connection located in right end compartment.
 2. All dimensions shown are in inches and are for reference only. For dimensions in mm, multiply inches by 25.4.

Direct expansion (DX) piping connection locations — 40UV, size 0750 only

DX Cooling Coil Only or DX Cooling with Re-Heat Coil (Size 0750 With Piping Package)

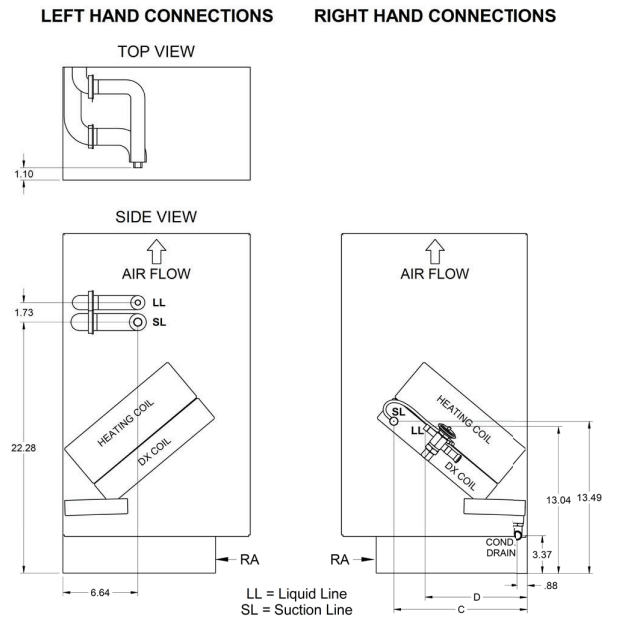

Unit Size 0750

- NOTE(S):
1. For dimensions C and D refer to DX Cooling Coil Piping Locations (Size 0750) table.
 2. Condensate drain connection located in right end compartment.
 3. All dimensions are in inches and are for reference only. For dimensions in mm, multiply inches by 25.4.

Chilled Water Coil with Pre-Heat Coil (With Piping Package)

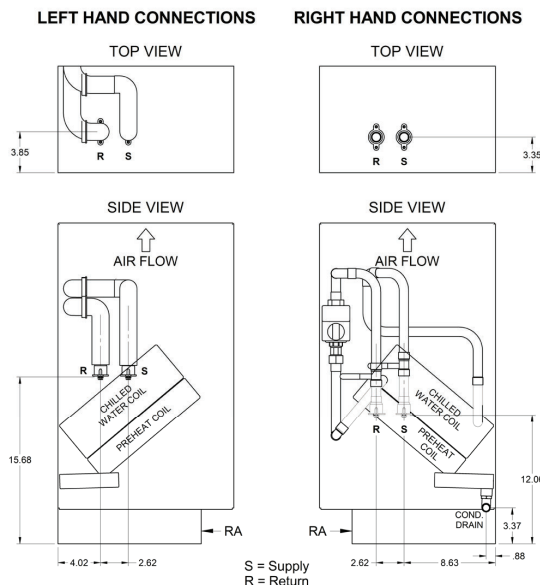

- NOTE(S):
1. Condensate drain connection located in right end compartment.
 2. All dimensions shown are in inches and are for reference only. For dimensions in mm, multiply inches by 25.4.

DX Cooling Coil with Pre-Heat Coil Only (Size 0750 With Piping Package)

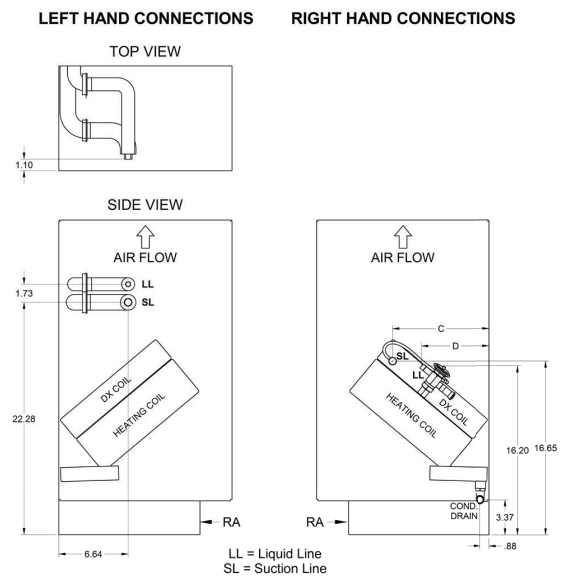

Unit Size 0750

- NOTE(S):
1. For dimensions C and D refer to DX Coil with Pre-Heat Piping Locations table.
 2. Condensate drain connection located in right end compartment.
 3. All dimensions are in inches and are for reference only. For dimensions in mm, multiply inches by 25.4.

Application data (cont)



Direct expansion (DX) Piping connection locations — 40UV, size 1000-1500

Hot water heating coil piping connection locations — 40UV

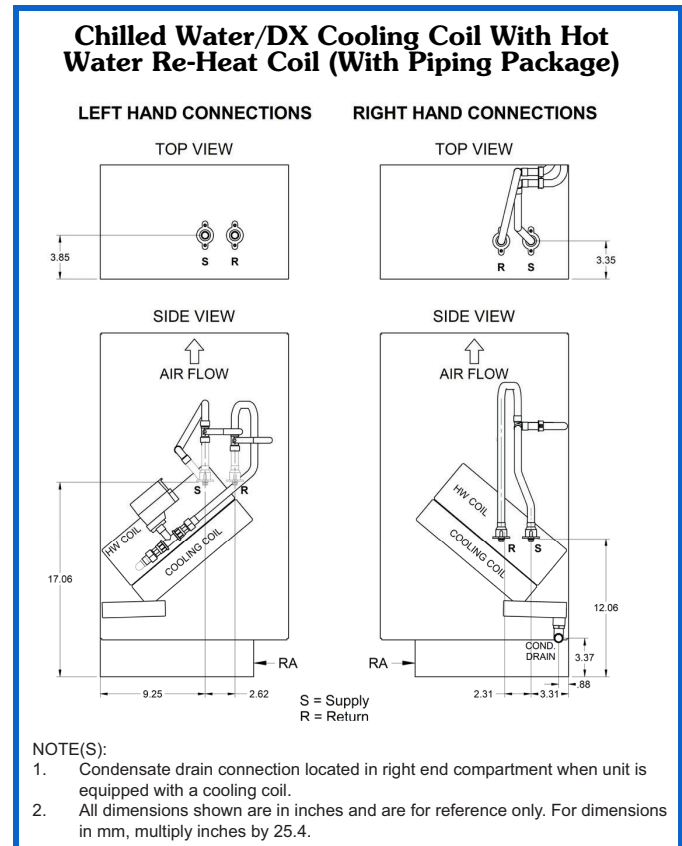
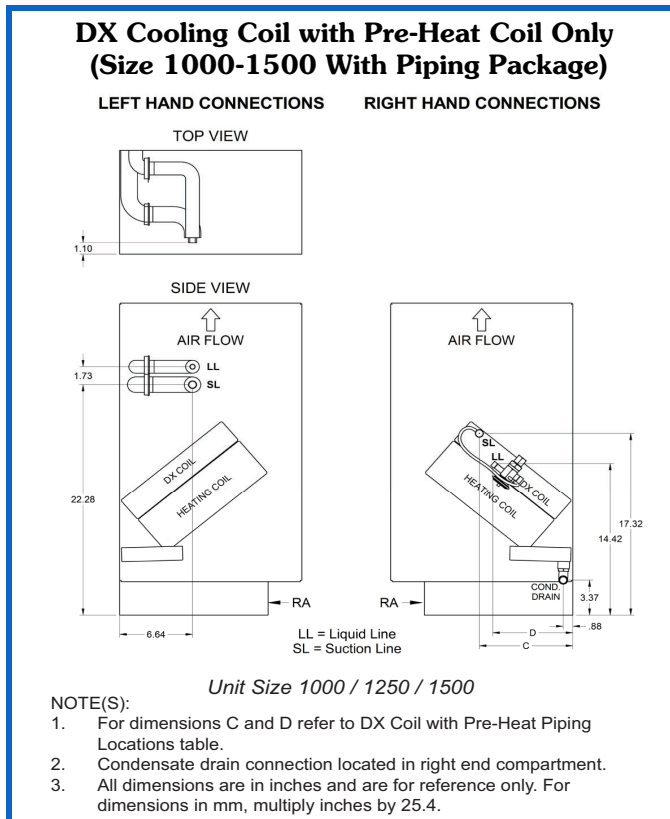
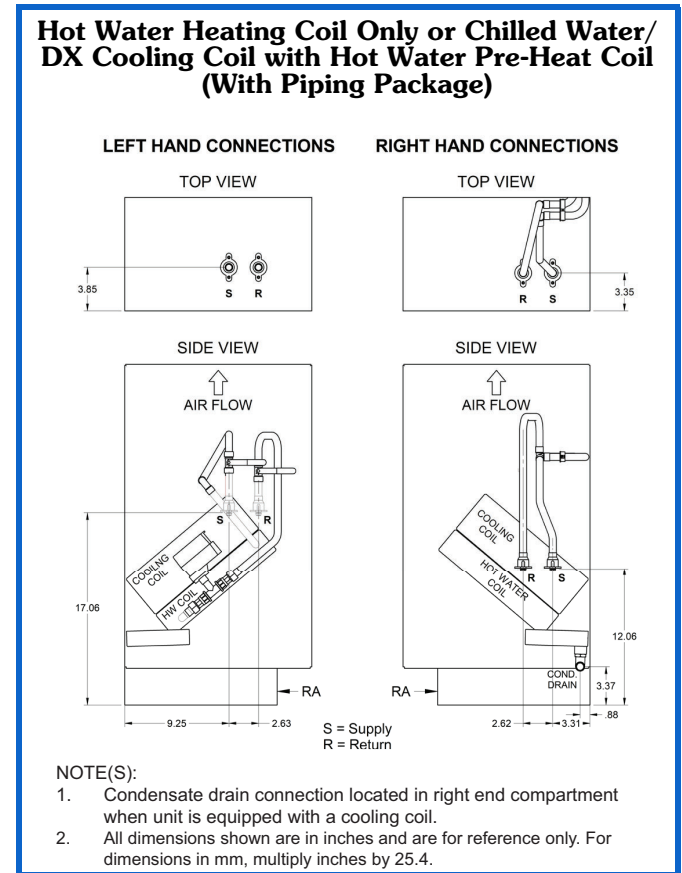
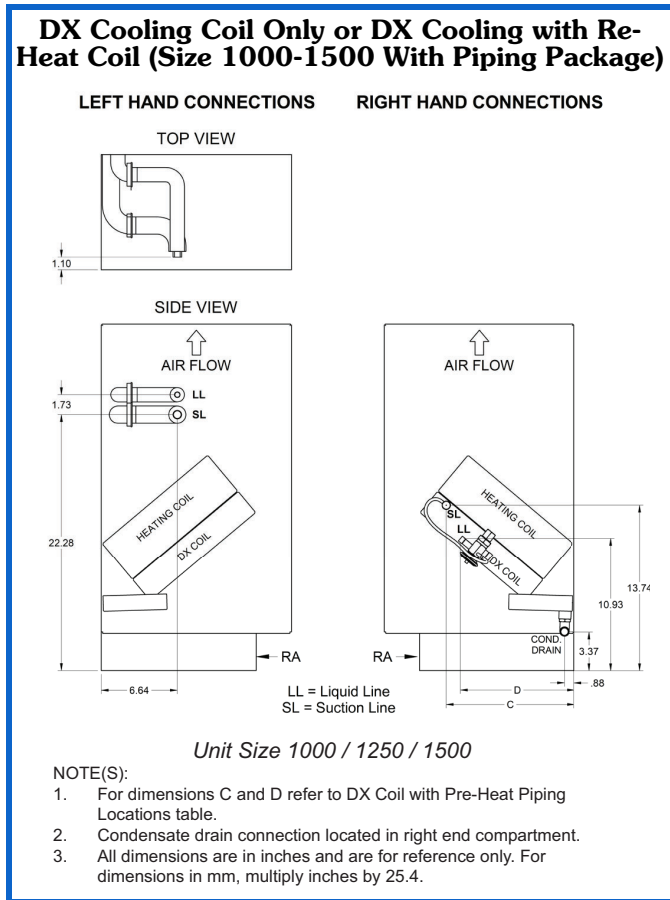

Application data (cont)



Steam heating coil piping connection locations — 40UV

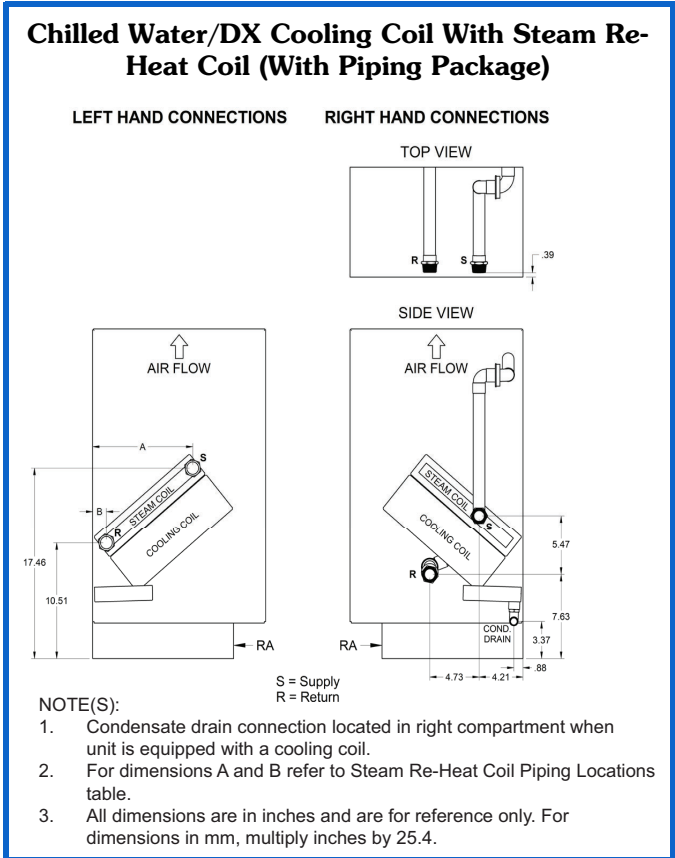
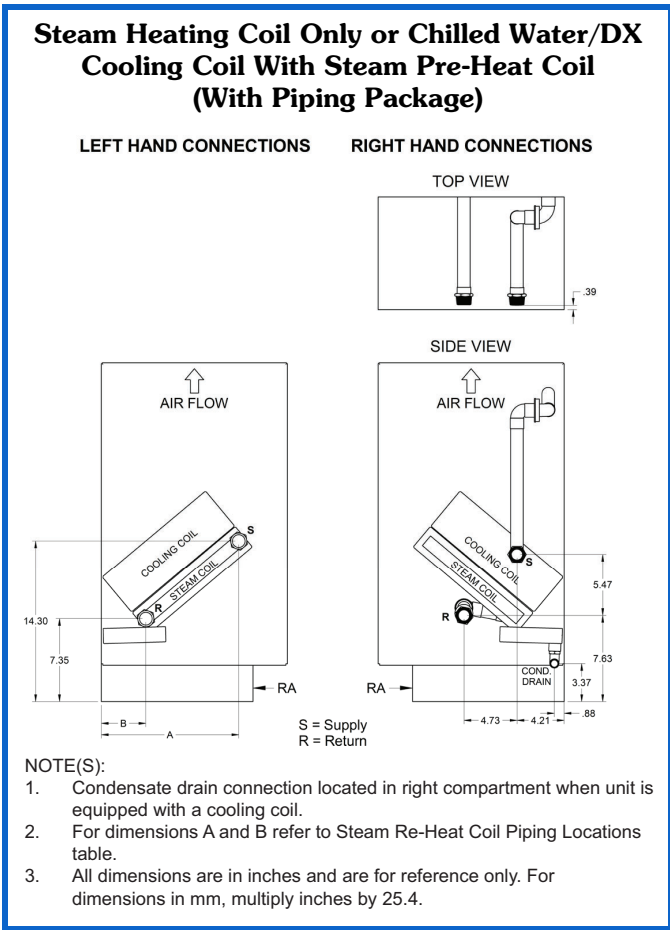

Valve control and face and bypass control

Valve control units

In a valve control unit all of the air passes through the coil. The flow of water through the coil is modulated to maintain the set point temperature in the room.

1. Air is drawn through the unit by the blowers (draw-thru design), conditioned and supplied to the room.
2. Return air enters through the lower front kick panel of the unit and outside air enters through the lower back panel of the unit.
3. The percentage of outside air and return air is controlled by the position of the outside air and return air dampers.
4. Air passes through the filters and then through the coil. The air is conditioned as it passes through the coil.
5. Cooling or heating capacity is controlled by adjusting the flow of water through the coil with a modulating valve. For units with DX cooling coils the outdoor condensing unit shall be energized on a call for cooling.

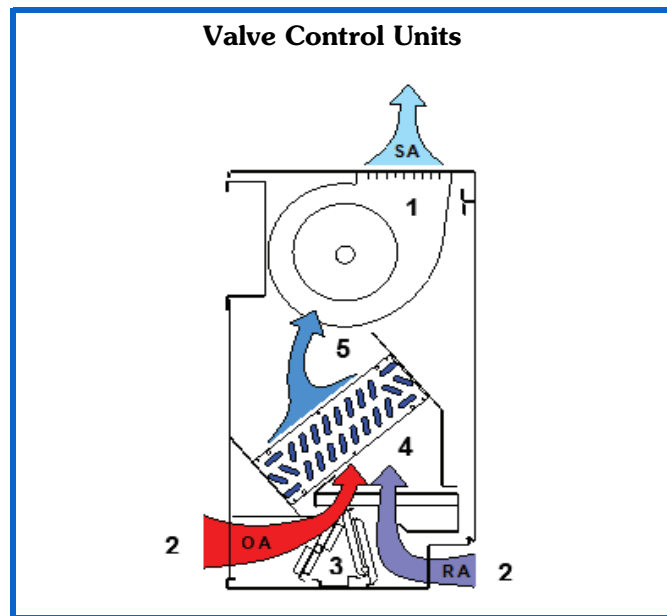

Face and bypass units

In a face and bypass unit the outside air and return air can be separated, to condition only the outside air, or mixed before passing through the coil. The face and bypass damper is modulated to maintain the setpoint temperature in the room.

1. Air is drawn through the unit by the blowers (draw-thru design), conditioned or bypassed and supplied to the room.
2. Return air enters through the lower front kick panel of the unit and outside air enters through the lower back panel of the unit.
3. The percentage of outside air and return air is controlled by the position of the outside air and return air dampers.
4. Air passes through the filters and then either passes through the coil or is diverted to bypass the coil. The

air passing through the coil is conditioned. Bypassed air is mixed with the conditioned air and delivered to the room.

5. Cooling or heating capacity is controlled by adjusting the face and bypass damper.

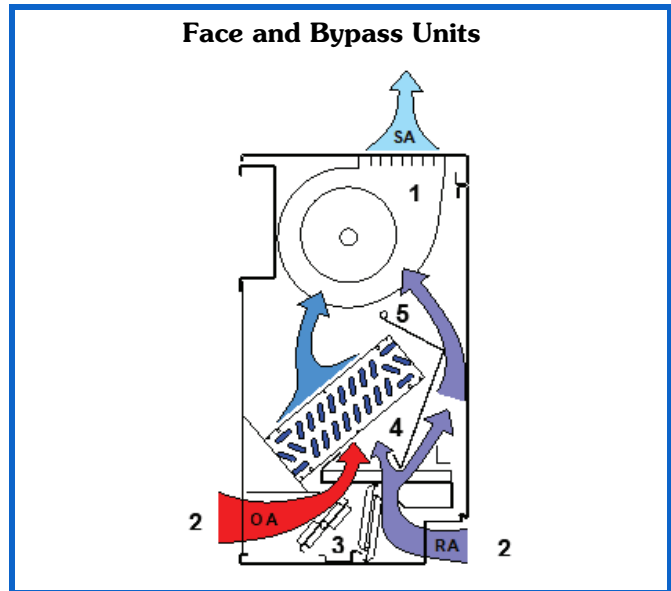

Chilled water/hot water face and bypass operation

For chilled water/hot water units, water flow and coil temperature remain constant to provide maximum dehumidification and low risk of coil freezing.

Dehumidification face and bypass and valve control comparison

Face and bypass control is the preferred method for maintaining indoor humidity levels compared to valve control. Due to the constant water flowing through the cooling coil, the surface temperature of the coil will remain cold to improve latent cooling and dehumidification. On valve controlled units, the water flow is modulated causing the surface temperature of the coil to increase. As a result, the coil's ability to remove moisture and dehumidify is reduced.

Coil freeze protection face and bypass and valve control comparison

Face and bypass control has a lower risk of coil freezing compared to valve control units. With face and bypass damper control, the water flow remains constant through the coil so the coil has a lower risk of freezing. With valve controlled units water can remain in the coil after the modulating control valve closes, which can freeze and damage the coil. A hot water coil freeze protection stat is recommended regardless of damper control type.

Recommended sequence of operation

The supply fan shall run at all times when unit is in occupied mode. When in unoccupied mode, the supply fan shall run only on a call for heating or cooling. The supply fan speed can be adjusted using the standard equipped manual 3-speed switch.

Freeze stat (optional)

On units equipped, an adjustable auto-resetting freeze stat is factory set to trip at 35°F. If the coil temperature reaches the limit and the freeze stat trips, it shall automatically reset

when the coil temperature rises 5°F above the setpoint. The freeze stat shall be wired so that upon tripping, power is removed from the supply fan, the outside air damper closes, and either the HW (Hot Water) valve opens or the face and bypass damper goes to full bypass.

Outside air and return air dampers (optional)

The outside air and return air dampers control the mixture of return air and outside air drawn through the unit. Both dampers are linked together and are controlled by an actuator requiring a 2 to 6 vdc proportional signal. At 2-v, the dampers are positioned for full return air and no outside air. At 6-v, the dampers are positioned for full outside air and no return air. The outside air damper shall open to a minimum position to provide ventilation requirements when the room is occupied. When in heating mode, if the space temperature is more than 4°F from the heating setpoint, the outside air damper shall fully close. The outside air damper shall also be fully closed during unoccupied mode. If the unit is equipped with a CO₂ sensor, the outside air damper shall modulate open proportionally to compensate for the CO₂ levels in the room.

The dampers can act as economizers for free-cooling. If cooling is required and the outside air temperature is below the economizer outside air lockout temperature (60°F recommended) and above 35°F (adjustable), the outside air damper shall modulate open. When the unit is in free-cooling, water valves shall be fully closed, and if equipped, the face and bypass damper should move to full bypass position.

Chilled water with valve control

Units with a chilled water coil controls requiring valve control shall use a non-spring return modulating valve operated by either a proportional (2 to 10 vdc) or a tri-state (24 vac) signal. When the room temperature is above the cooling setpoint, the valve shall open proportionally according to the adjustable proportional band.

Chilled water with face and bypass control

Units equipped with a chilled water coil and face and bypass control shall modulate the face and bypass damper via a spring return actuator, controlled by a proportional signal (2-5.5-v). The face and bypass damper regulates the amount of return air and outside air passing through the chilled water coil. On a call for cooling, the damper shall open to the face of the coil proportionally based on how many degrees the room temperature is from the setpoint. When the damper is in full bypass position (2-v), all return and outside air bypasses the chilled water coil. When the damper is in full face position (5.5-v), all return and outside air passes through the chilled water coil.

Direct expansion (DX) cooling control

When the room temperature is above the cooling setpoint, the compressor will be energized. The compressor will deenergize when the room temperature falls below the cooling setpoint. If the factory-installed low limit stat detects indoor evaporator coil temperatures below its setpoint, the compressor will be disabled.

If the refrigerant detection system detects a leak, the fan motor will be energized and a signal to disable the compressor and all other functions will be initiated.

Hot water or steam with valve control

Units with hot water or steam coil controls and valve control shall use a spring-return, normally open modulating

valve operated by a proportional signal (2 to 10 vdc) or a tri-state (24 vac) signal. When the room temperature is below the heating setpoint, the valve shall open proportionally according to the adjustable proportional band. If for any reason the supply air temperature drops below 55°F (adjustable), the valve shall modulate open to maintain 55°F.

Hot water with face and bypass control

Units equipped with a hot water or steam coil and face and bypass control shall modulate the face and bypass damper via a spring return actuator, controlled by a proportional signal (5.5-v). The face and bypass damper regulates the amount of return air and outside air passing through the heating coil. On a call for heating, the damper shall open proportionally based on how many degrees the room temperature is from the setpoint. When the damper is in full bypass position (2-v), all return and outside air bypasses the heating coil. When the damper is in full face position (5.5-v), all return and outside air passes through the heating coil. If for any reason the supply air temperature drops below 55°F (adjustable), the heating valve shall open (if equipped) and the face and bypass damper shall modulate to maintain 55°F.

Hot water and chilled water (2-pipe) with valve control

Units with valve control to provide heating and cooling on a single water coil (2-pipe system) shall use a spring-return, normally open modulating valve operated by a proportional signal (2-10 vdc) or a tri-state (24 vac) signal. On a call for heating or cooling (depending on the season), the valve shall open proportionally based on how many degrees the room temperature is from the setpoint. If for any reason the supply air temperature drops below 55°F (adjustable), the water valve shall modulate open to maintain 55°F. On 2-pipe units connected to a network, an optional aquastat is recommended to prevent inadvertent changeover of heating/cooling modes.

Hot water and chilled water (2-pipe) with face and bypass control

Units with face and bypass control to provide heating and cooling on a single water coil (2-pipe system) shall modulate the face and bypass damper via a spring return actuator, controlled by a proportional signal (2-5.5-v). The face and bypass damper regulates the amount of return air and outside air passing through the water coil. On a call for heating or cooling (depending on the season), the damper shall open proportionally based on how many degrees the room temperature is from the setpoint. When the damper is in full bypass position (2-v), all return and outside air bypasses the water coil. When the damper is in full face position (5.5-v), all return and outside air passes through the water coil. If for any reason the supply air temperature drops below 55°F (adjustable), the water valve shall open (if equipped) and the face and bypass damper shall modulate to maintain 55°F.

2-Position control valves

Optional spring-return, 2-position control valves can be used to control the end of cycle flow on both chilled and hot water coils. On a chilled water coil, a normally closed valve is used. On a hot water coil or 2-pipe changeover system, a normally open valve is used.

The 2-position valve used on a chilled water coil shall open on a call for cooling when the outside air temperature is

greater than 55°F (adjustable). When the outside air temperature is less than 55°F, the valve should remain closed and free cooling shall be utilized. The 2-position chilled water valve shall be closed when the 2-position hot water valve is open (when equipped). The valve is controlled by a 24 vac digital output.

The 2-position valve used on a hot water coil shall open on a call for heating. The valve shall always open when the outside air temperature drops below 40°F. This is to prevent the coil from freezing or nuisance tripping of the freeze stat. The 2-position hot water valve shall be closed when the 2-position chilled water valve is open (if equipped). The valve is controlled by a 24 vac digital output.

The 2-position valve used on a 2-pipe changeover system shall operate like the 2-position chilled water valve in

cooling mode, and like the 2-position hot water valve in heating mode.

Condensate pump (optional)

On units equipped with a condensate pump, the pump shall begin to run once the condensate reaches a set level. The pump comes with an internal safety switch that can be wired either normally open or normally closed. The safety switch shall be wired such that the chilled water valve closes when it trips.

Condensate pan float switch (optional)

On units equipped with a condensate pan float switch, the normally closed switch shall be wired such that the chilled water valve closes or the outdoor condensing unit is disabled (DX cooling models only) upon tripping.

Unit Ventilator Series — Vertical

HVAC Guide Specifications — 40UV/UH

Size Range: 750 to 1500 Nominal cfm

Carrier Model Numbers:

40UH (Horizontal)

40UV (Vertical)

Part 1 — General

1.01 SYSTEM DESCRIPTION

- A. The supplied product shall be a Carrier chilled water cooling/hot water heating or combined chilled water cooling and hot water or steam heating unit ventilator. The unit shall be floor-mounted and horizontally configured with adjustable leg levelers. All access and maintenance shall be through the front and the top side panels of the unit.
- B. The supplied product shall be a Carrier split DX (direct expansion) cooling only or a combined split DX cooling with hot water or steam heating unit ventilator. The unit shall be floor-mounted and horizontally configured with adjustable leg levelers. All access and maintenance shall be through the front and the top side panels of the unit.
- C. The supplied product shall be a Carrier chilled water cooling/hot water heating or combined chilled water cooling and hot water or steam heating unit ventilator. The unit shall be ceiling-mounted using field supplied rods and fasteners. All access and maintenance shall be through the bottom access panels of the unit.
- D. The supplied product shall be a Carrier split DX cooling only or a combined split DX cooling with hot water or steam heating unit ventilator. The unit shall be ceiling-mounted using field supplied rods and fasteners. All access and maintenance shall be through the bottom access panels of the unit.

1.02 SUBMITTALS

- A. General:

This document must be carefully reviewed by the Engineer to ensure it meets the requirements of the project and local building code(s).
- B. As Carrier has a Continuous Product Improvement program, it reserves the right to change design and specifications without notice.

1.03 QUALITY ASSURANCE

- A. The unit shall be constructed and listed in accordance with ETL and CSA standards (UL 60335-2-40:2022 Ed.4) (CSA C22.2#60335-2-40:2022 Ed.4).
- B. The unit shall be constructed following ISO: 9001 quality control program procedures and be fully assembled and tested prior to shipment.
- C. ASHRAE Compliance: Applicable requirements in ASHRAE 62.1-2010, Section 5 - "Systems and Equipment" and Section 7 - "Construction and Startup".

D. Manufacturer Qualifications:

Company specializing in manufacturing the products specified in this section with minimum ten years documented experience.

Part 2 — Products

A. 40UV UNIT:

1. Cabinet Construction:

The exterior panels of the cabinet shall be constructed of 16 gauge sheet steel, degreased and coated with electrostatically applied baked-on polyester powder paint.

2. Fresh and Return Air (Standard):

Unit shall provide an opening in rear for fresh air. Return air is from bottom front of unit.

3. Return Air Only (Optional):

Return air is from bottom front of unit. No provisions for fresh air.

4. Pipe Tunnel (Standard):

Unit shall utilize an open rear pipe tunnel.

5. Pipe Tunnel (Optional):

Unit shall utilize a closed rear pipe tunnel.

6. Service and Maintenance Access:

All service and maintenance access shall be possible through the top and front of the unit only.

7. Service and Maintenance Access:

All service and maintenance access shall be possible through the top and front of the unit only.

8. The front panel and compartment panels shall be easily removable with tamperproof fasteners securing it to the rest of the unit cabinet.

9. The back of the cabinet shall have an opening for connection to a wall sleeve and louver. (optional)

10. Discharge Air (optional):

The unit shall have a pencil-proof clear anodized aluminum supply air bar grille and 1/4 in. galvanized steel mesh mounted on the top panel.

B. 40UH UNIT:

1. Cabinet Construction:

The exterior panels of the cabinet shall be constructed of 18 gauge sheet steel, degreased and coated with electrostatically applied baked-on polyester powder paint.

2. Fresh and Return Air (Optional):

a. Return air provided from bottom return air louvers. Fresh air is from rear duct collar.

b. Return air provided from bottom return air louvers. Fresh air is from top duct collar.

c. Return air provided from rear duct collar. Fresh air is from top duct collar.

d. Return air provided from rear lower duct collar. Fresh air is from rear upper duct collar.

3. Return Air Only (Standard):

Return air provided from bottom return air louvers. No provisions for fresh air.

4. Return Air Only (Optional):

Return air provided from rear duct collar. No provisions for fresh air.

5. Service and Maintenance Access:

All service and maintenance access shall be possible through the bottom of the unit only.

6. The bottom panels shall be easily removable with tamper proof fasteners securing them to the rest of the unit cabinet.

7. Discharge Air (optional):

- a. The unit shall have a front discharge duct collar for connection to field installed ductwork supplied by others.
- b. The unit shall have a front discharge duct collar for connection to field-installed ductwork supplied by others.
- c. The unit shall have a clear anodized aluminum supply double deflection front discharge grille.
- d. The unit shall have a clear anodized aluminum supply double deflection down discharge grille.

C. ALL UNITS

1. Unit Color:

The standard unit color shall be Beige. Optional unit colors are Sky White or Light Gray.

2. Paint finish shall be easily cleanable and hard wearing to give maximum protection.

3. Insulation:

1 in. thick, acoustic Hushcloth^{®1} Polyester/Polyurethane foam with density of 2-pounds per cubic foot containing no fibrous materials.

4. Fire-Hazard Classification:

Insulation shall have a fire rating of UL94HF-1.

5. Airstream Surfaces:

Surfaces in contact with the airstream shall comply with requirements in ASHRAE 62.1-2010.

6. Drain Pan:

Each unit shall be fitted with a 20 gauge, 304 stainless steel welded construction drain pan sloped in 3 directions. The condensate connection will be at the same side as the chilled water or DX coil access side and include 3/4 in. reinforced condensate tubing and splashguard over the drain port.

2.01 COILS

A. Evaporator Coil (Optional): Direct expansion units include a factory installed thermal expansion valve rated for use with R-454B refrigerant and utilize large surface area evaporator coils ideally positioned to optimize heat transfer and airflow. Each evaporator is manufactured from refrigeration quality copper tubes with mechanically bonded aluminum fins.

1. Unit with DX Coils shall include A2L leak detection and safety controls. The refrigerant detection system shall be wired to energize the supply fan and disable all other unit operation in the event of a refrigerant leak.

B. Water/Steam Coil (Optional):

Large surface area slab coils shall be utilized to optimize heat transfer and airflow. Each coil shall be manufactured from refrigeration quality 3/8 in. diameter copper tubing mechanically bonded onto aluminum Highmix^{®1} fins with coil circuitry designed to ensure minimum waterside pressure drops. Each coil shall be fitted with an air bleed at the high point of the coil and a drain plug at the low point.

2.02 FANS AND MOTORS

A. The fan motor shall be an electronically commutated motor (ECM). The DC motor features a brush-less, permanently lubricated ball bearing construction for maintenance free operation.

B. (Optional) The high-static constant torque ECM shall compensate for up to 0.25 in. wg.

C. The fan assembly shall be positioned for a "draw thru" configuration.

2.03 FILTERS

A. Standard:

Throwaway 1 in. thick 50 to 65% arrestance filters shall be provided and installed at the factory and located to provide filtration of the outdoor and return air prior to being conditioned.

B. Optional:

1. 1 in. thick disposable cotton and synthetic blend filters shall be provided and installed at the factory and located to provide filtration of the outdoor and return air prior to being conditioned. Minimum Efficiency Reporting Value of MERV 10 per ASHRAE standard 52.2.
2. 1 in. thick disposable cotton and synthetic blend filters shall be provided and installed at the factory and located to provide filtration of the outdoor and return air prior to being conditioned. Minimum Efficiency Reporting Value of MERV 13 per ASHRAE standard 52.2.

2.04 DAMPERS (OPTIONAL)

A. Fresh and Return Air Dampers:

1. Each unit shall be fitted with separate outside air and return air dampers.
2. The dampers shall have the capability of permitting only the outside air into the space, or

1. Third-party trademarks and logos are the property of their respective owners.

recycling the return air and allowing only a minimum of outside air to enter the space.

3. Full modulation allowing any mixture of outside air and return air shall be possible.

B. Fresh and Return Air Dampers Construction:

1. The outside air damper is constructed of galvanized steel and the return air damper is constructed of aluminum.
2. Dampers shall be gasketed to prevent air bypass and shall pivot on self-lubricating nylon bearings.

C. Face and Bypass Damper:

1. Each unit shall be fitted with an optional factory installed face and bypass damper constructed of aluminum and braced for rigidity.
2. The damper shall include EPDM rubber end seal and F3 wool felt side seals.
3. The damper shall be removable to allow access to the coil(s).

NOTE: For DX Cooling units with Face and Bypass Damper, the damper must be in the full face mode on call for cooling enabling the condensing unit by others. Full airflow must pass across the evaporator coil.

2.05 CONTROLS

A. Standard:

1. 40UV Unit:
 - a. The control panel is located in the left-hand compartment.
2. 40UH Unit:
 - a. The slide-out control panel is located under the bottom access panel.
3. The unit shall be fitted with a power disconnect switch sized for the full load amperage of the unit to enable the unit to be disconnected from the power supply prior to any maintenance.
4. Field installed and provided by others:
 - a. Controller
 - b. Controls Transformer
 - c. Damper Actuators
5. All components located in the panel shall be clearly marked for easy identification.
6. All terminal blocks and wires shall be individually numbered.
7. All electrical wires in the control panel shall be run in an enclosed trough.
8. Wiring outside the control panel shall be run in protective sleeves.

B. Optional:

1. The 3-speed selector switch enables adjustment of the supply air volume.
2. The supply air volume will be adjusted via a 0-10 vdc signal.

3. DDC Ready Controls:

- a. Factory-installed DDC ready controls shall include a fan relay, 75VA 24-v control circuit transformer, return air, outside air and supply air sensors, and terminal strip.
- b. Sensors are NTC 10K Type II.
- c. Controls also include a 2-10 vdc outside air and/or face and bypass damper actuator where applicable.

4. Aquastat: An aquastat shall be fitted to 2-pipe systems to prevent changeover into a heating mode when cooling is required and vice-versa.

5. Condensate Pump:

- a. The unit shall be fitted with a condensate pump.
- b. The pump shall have a 1/30th hp motor capable of 20 gph at 15 ft of lift with rust-proof, ABS plastic tank with built-in flow check valve and safety switch.

6. Condensate Pan Float Switch:

The unit shall be fitted with a float switch mounted on the condensate pan to stop the cooling function should the condensate rise to a predetermined level.

7. Freeze Stat:

- a. The unit shall be fitted with a freeze protection sensor mounted on the discharge side of the first coil to prevent any freezing of the water coil assembly.
- b. When the sensor detects a freeze up condition it shall shut the damper and force the flow control valve open and prevent the unit supply fan from running.

NOTE: Carrier recommends full airflow across coil in cooling mode (no bypass operation) to prevent DX coil from freezing.

8. Supply Fan Current Switch Option:

The unit shall be provided with an internally mounted current switch to monitor the status of the supply fan. The switch contacts shall be wired to the unit terminal strip.

2.06 PIPING COMPONENTS

A. Factory Installed Cooling Piping Components (Optional):

1. The 3/4 in. chilled water (or 2-pipe HW/CW) piping components shall be factory assembled, with all the necessary piping and unions, inside the side compartment and outside of the airstream of the unit ventilator.
2. Two-way modulating valve shall be provided for capacity control of chilled water. The capacity control valve shall be controlled by a 2 to 10 vdc signal from the unit mounted controller.
3. Three-way modulating valve shall be provided for capacity control of chilled water. The capacity control valve shall be controlled by a

2 to 10 vdc signal from the unit mounted controller.

4. Two-way 2-position normally closed spring return control valve shall be provided for control of chilled water coil. The control valve shall be controlled by a 24-v signal from the units control panel.
 5. Three-way 2-position spring return control valve shall be provided for control of chilled water coil.
 6. The control valve shall be controlled by a 24-v signal from the units control panel:
 - a. Two-way 2-position normally open spring return control valve shall be provided for control of chilled water/hot water coil.
 - b. The control valve shall be controlled by a 24-v signal from the units control panel.
 7. Heavy duty forged brass ball-valve construction balancing valve.
 8. Manually adjustable ball-valve construction balancing valve with Schrader¹ style pressure ports and drain port.
 9. Blowdown valve with hose connector and cap.
 10. A set of two heavy duty forged brass ball valves, one for the supply and one for the return.
 11. Heavy duty cast iron strainer with 20 mesh 304 stainless steel screen, gasketed and tapped retainer cap and blow-off outlet.
- B. Factory-Installed Heating Piping Components (Optional):
1. 3/4 in. hot water piping components shall be factory assembled (2-pipe HW/CW coil), with all the necessary piping and unions, inside the side compartment and outside of the airstream of the unit ventilator.
 2. 1/2 in. hot water piping components shall be factory assembled, with all the necessary piping and unions, inside the side compartment and outside of the airstream of the unit ventilator.
 3. Two-way modulating valve shall be provided for capacity control of hot water coil.
 - a. The capacity control valve shall be controlled by a 2 to 10 vdc signal from the unit mounted controller.
 4. Three-way modulating valve shall be provided for capacity control of hot water coil.
 - a. The capacity control valve shall be controlled by a 2 to 10 vdc signal from the unit mounted controller.
 5. Two-way 2-position normally closed spring return control valve shall be provided for control of hot water coil.

The control valve shall be controlled by a 24-v signal from the units control panel.

6. Three-way 2-position spring return control valve shall be provided for control of hot water coil.

The control valve shall be controlled by a 24-v signal from the units control panel.

7. Two-way 2-position normally open spring return control valve shall be provided for control of chilled water/hot water coil.

The control valve shall be controlled by a 24-v signal from the units control panel.
 8. Heavy duty forged brass ball-valve construction balancing valve.
 9. Manually adjustable ball-valve construction balancing valve with Schrader style pressure ports and drain port.
 10. Blowdown valve with hose connector and cap.
 11. A set of two heavy duty forged brass ball valves, one for the supply and one for the return.
 12. Heavy duty cast iron strainer with 20 mesh 304 stainless steel screen, gasketed and tapped retainer cap and blow-off outlet.
- 2.07 FIELD INSTALLED ACCESSORIES
- A. Optional:
1. Side Panel(s): Factory supplied side panel(s) constructed of 14 gauge sheet steel and painted to match the unit shall be field mounted to the base unit.
 2. Utility Compartment(s): Factory supplied utility compartment(s) with 14 gauge sheet steel front and top panel(s) and painted to match the unit shall be field mounted to the base unit.
 3. Filler Section(s):
 - a. Factory supplied filler section(s) constructed of 16 gauge sheet steel and painted to match the unit shall be field mounted.
 - b. Filler section(s) can be field cut for custom widths.
 - c. Filler section includes a kick plate that can be field trimmed to accommodate the unit sub base height up to 6 in.
 4. Unit Sub-Base:
 - a. Unit height adjustments can be made with a sub-base field mounted under the standard unit.
 - b. The sub-base is fully enclosed, constructed of heavy duty steel and painted to match the base of the standard unit.
 5. Utility Compartment Sub-Base:
 - a. Utility compartment height adjustments can be made with a sub-base field mounted under the standard utility compartment.
 - b. The sub-base is fully enclosed, constructed of heavy duty steel and painted to match the base of the standard utility compartment.

1. Third-party trademarks and logos are the property of their respective owners.

6. Wall Sleeve:
 - a. The wall sleeve shall be constructed from galvanized steel.
 - b. The sleeve shall be field assembled and insulated by the installing contractor with foil back insulation.
7. Outdoor Louver:
 - a. An outdoor louver suitable for masonry, glass, or panel wall construction.
 - b. The louvers are flanged style with the following finish:
 - 1) Aluminum with bird screen and a clear anodized finish—Greenheck ESU150 Model.
 - 2) Aluminum with bird screen and a clear anodized finish—Greenheck ESD435 Model - AMCA rated.
8. Spare Filters: 1 in. spare filter(s) shall be supplied with the unit.
9. Return Air Kickplate: Unit shall be supplied with a field installed slotted return air kickplate

to cover the standard rectangular openings in the unit base.

2.08 EXAMINATION

- A. Prior to start of installation, examine area and conditions to verify correct location for compliance with installation tolerances and other conditions affecting unit performance. See unit Installation and Service Manual.
- B. Examine roughing-in of plumbing, electrical and HVAC services to verify actual location and compliance with unit requirements. See unit Installation and Service Manual.
- C. Proceed with installation only after all unsatisfactory conditions have been corrected.

2.09 INSTALLATION

- A. Installation shall be accomplished in accordance with these written specifications, project drawings, manufacturer's installation instructions as documented in manufacturer's Installation and Service Manual, Best Practices and all applicable building codes.

