



Controls, Start-Up, Operation, Service and Troubleshooting Instructions

CONTENTS

| | Page | | Page |
|---|-------|--|------|
| SAFETY CONSIDERATIONS | 2 | | |
| GENERAL | 2 | | |
| BASIC CONTROL USAGE | 2-5 | | |
| <i>ComfortLink™</i> Control | 2 | | |
| Scrolling Marquee | 3 | | |
| Accessory Navigator™ Display | 3 | | |
| Operation | 3 | | |
| System Pilot™ | 4 | | |
| CCN Tables and Display | 4 | | |
| Conventions Used in this Manual | 4 | | |
| START-UP | 6-35 | | |
| Unit Preparation | 6 | | |
| Compressor Mounting | 6 | | |
| Refrigerant Service Ports | 6 | | |
| Crankcase Heater(s) | 6 | | |
| Compressor Rotation | 6 | | |
| Internal Wiring | 6 | | |
| Subcooler Heat Exchanger (SHX) | 6 | | |
| Evaporator Fan | 6 | | |
| Condenser Fans and Motors | 6 | | |
| Return-Air Filters | 6 | | |
| Outdoor-Air Inlet Screens | 6 | | |
| Gas Heat (48PG Only) | 6 | | |
| Orifice Change (48PG Only) | 7 | | |
| Power Supply | 7 | | |
| Air Baffles | 7 | | |
| Accessory Installation | 7 | | |
| CONTROLS QUICK START | 35,36 | | |
| Thermostat Control | 35 | | |
| Space Temperature Sensor Control — Direct Wired (T-55 or T-56) | 35 | | |
| Space Temperature Sensor Control — CCN (T-58) | 35 | | |
| Space Temperature Sensor Control — CCN Linkage | 35 | | |
| Space Humidity Control — Humidistat | 35 | | |
| Space Humidity Control — Thermidistat™ | 35 | | |
| Space Humidity Control — Relative Humidity Sensor | 35 | | |
| CCN Communication | 35 | | |
| Accessories | 35 | | |
| Service Test | 35 | | |
| Control Configuration Checklist | 36 | | |
| Programming Operating Schedules | 36 | | |
| SERVICE TEST | 36-38 | | |
| THIRD PARTY CONTROL | 38,39 | | |
| Thermostat | 38 | | |
| Humidistat | 38 | | |
| Humidity Sensor | 38 | | |
| Remote Occupancy | 38 | | |
| Fire Shutdown | 38 | | |
| Alarm Output | 38 | | |
| Outdoor Enthalpy | 38 | | |
| IAQ Switch | 39 | | |
| IAQ Sensor | 39 | | |
| OAQ Sensor | 39 | | |
| CONTROLS OPERATION | 39-52 | | |
| Display Configuration | 39 | | |
| Modes | 39 | | |
| Unit Configuration | 39 | | |
| Occupancy Determination | 40 | | |
| Indoor Fan | 41 | | |
| Cooling | 41 | | |
| • THERMOSTAT CONTROL | | | |
| • SPACE SENSOR CONTROL | | | |
| • OUTDOOR FANS | | | |
| Gas Heating (48PG Units) | 42 | | |
| • THERMOSTAT CONTROL | | | |
| • SPACE SENSOR CONTROL | | | |
| • SUPPLY AIR TEMPERATURE (SAT) SENSOR | | | |
| Electric Heat (50PG Units) | 44 | | |
| • THERMOSTAT CONTROL | | | |
| • SPACE SENSOR CONTROL | | | |
| • SUPPLY AIR TEMPERATURE (SAT) SENSOR | | | |
| Economizer | 44 | | |
| • THERMOSTAT CONTROL | | | |
| • SPACE SENSOR CONTROL | | | |
| • ECONOMIZER ACTUATOR COMMUNICATIONS | | | |
| • UNOCCUPIED FREE COOLING | | | |
| • POWER EXHAUST | | | |
| Optional Humidi-MiZer Dehumidification System | 45 | | |
| • SETTING UP THE SYSTEM | | | |
| • REHEAT MODE SELECTION PROCESS | | | |
| • REHEAT MODE DIAGNOSTIC HELP | | | |
| • AIR BAFFLES | | | |
| Indoor Air Quality | 49 | | |
| Temperature Compensated Start | 51 | | |
| Carrier Comfort Network® (CCN) Configuration | 51 | | |
| Alarm Handling | 52 | | |
| TROUBLESHOOTING | 52-67 | | |
| Complete Unit Stoppage | 52 | | |
| Restart Procedure | 54 | | |
| Control Module Communication | 54 | | |
| Alarms and Alerts | 54 | | |
| • VIEWING AND CLEARING UNIT ALARMS | | | |
| • DIAGNOSTIC ALARM CODES AND POSSIBLE CAUSES | | | |
| Cooling Troubleshooting | 57 | | |
| Humidi-MiZer Troubleshooting | 57 | | |
| Economizer Troubleshooting | 57 | | |
| Heating Troubleshooting | 60 | | |
| Phase Loss Protection | 60 | | |
| Thermistor Troubleshooting | 61 | | |
| Transducer Troubleshooting | 64 | | |
| Forcing Inputs and Outputs | 64 | | |
| MAJOR SYSTEM COMPONENTS | 67-84 | | |
| General | 67 | | |
| Main Base Board (MBB) | 67 | | |
| Economizer Control Board (ECB) | 67 | | |
| Integrated Gas Control (IGC) Board | 67 | | |
| Low Voltage Terminal Strip (TB2) | 67 | | |
| Scrolling Marquee Display | 80 | | |
| Accessory Navigator™ Display | 80 | | |
| Carrier Comfort Network® Interface | 80 | | |
| Subcooler Heat Exchanger | 80 | | |
| Field-Installed Accessories | 82 | | |
| • SPACE TEMPERATURE SENSOR (T-55) | | | |
| • SPACE TEMPERATURE SENSOR (T-56) | | | |
| • SPACE TEMPERATURE SENSOR (T-58) | | | |
| • SPACE TEMPERATURE SENSOR AVERAGING | | | |
| • ECONOMIZER | | | |
| • POWER EXHAUST | | | |
| • TWO-POSITION DAMPER | | | |
| • INDOOR AIR QUALITY | | | |
| • OUTDOOR AIR QUALITY | | | |
| • SMOKE DETECTORS | | | |
| • FILTER STATUS | | | |
| • FAN STATUS | | | |

CONTENTS (cont)

| | Page |
|---|--------------|
| • ENTHALPY SENSORS | |
| • RETURN/SUPPLY AIR TEMPERATURE SENSOR | |
| • SPACE HUMIDITY SENSOR | |
| • ELECTRIC HEAT | |
| SERVICE | 85-92 |
| Cleaning | 85 |
| Lubrication | 86 |
| Manual Outdoor Air Damper | 87 |
| Economizer Adjustment | 87 |
| Evaporator Fan Service and Replacement | 87 |
| Evaporator Fan Performance Adjustment | 87 |
| Evaporator Fan Belt Tension Adjustment | 88 |
| Condenser-Fan Adjustment | 88 |
| Verify Sensor Performance | 88 |
| Economizer Operation During Power Failure | 88 |
| Evacuation | 88 |
| Refrigerant Charge | 89 |
| Gas Valve Adjustment (48PG Only) | 90 |
| High Altitude (48PG Only) | 90 |
| Main Burners (48PG Only) | 91 |
| Filter Drier | 92 |
| Protective Devices | 92 |
| Relief Devices | 92 |
| Control Circuit 24-V | 92 |
| Replacement Parts | 92 |
| Diagnostic LEDs | 92 |
| APPENDIX A — LOCAL DISPLAY AND CCN TABLES | 93-103 |
| APPENDIX B — CONTROL MODES WITH HUMIDI-MIZER SYSTEM AND ECONOMIZER | 104 |
| CONTROL SET UP POINT AND CONFIGURATION LOG | CL-1 to CL-5 |
| UNIT START-UP CHECKLIST | CL-6 |

SAFETY CONSIDERATIONS

Installation and servicing of air-conditioning equipment can be hazardous due to system pressure and electrical components. Only trained and qualified service personnel should install, repair, or service air-conditioning equipment. Untrained personnel can perform the basic maintenance functions of replacing filters. Trained service personnel should perform all other operations.

When working on air-conditioning equipment, observe precautions in the literature, tags and labels attached to the unit, and other safety precautions that may apply. Follow all safety codes. Wear safety glasses and work gloves. Use quenching cloth for unbrazing operations. Have fire extinguishers available for all brazing operations.

⚠ WARNING

Before performing service or maintenance operation on unit turn off and lock off main power switch to unit. Electrical shock can cause personal injury and death. Shut off all power to this equipment during installation and service. The unit may have an internal non-fused disconnect or a field-installed disconnect.

⚠ CAUTION

This unit uses a microprocessor-based electronic control system. **Do not** use jumpers or other tools to short out components or to bypass or otherwise depart from recommended procedures. Any short-to-ground of the control board or accompanying wiring may destroy the electronic modules or electrical components.

⚠ WARNING

1. Improper installation, adjustment, alteration, service, or maintenance can cause property damage, personal injury, or loss of life. Refer to the User's Information Manual provided with this unit for more details.
2. Do not store or use gasoline or other flammable vapors and liquids in the vicinity of this or any other appliance.

What to do if you smell gas:

1. DO NOT try to light any appliance.
2. DO NOT touch any electrical switch, or use any phone in your building.
3. IMMEDIATELY call your gas supplier from a neighbor's phone. Follow the gas supplier's instructions.
4. If you cannot reach your gas supplier call the fire department.

GENERAL

This publication contains Start-Up, Controls, Operation, Service, and Troubleshooting information for the 48/50PG rooftop units. See Table 1. These units are equipped with ComfortLink™ controls and use Puron® refrigerant.

Table 1 — Unit Sizes (48/50PG)

| UNIT | NOMINAL TONS |
|------------------|--------------|
| 48/50PG20 | 18 |
| 48/50PG24 | 20 |
| 48/50PG28 | 25 |

BASIC CONTROL USAGE

ComfortLink Control — The ComfortLink control is a comprehensive unit-management system. The control system is easy to access, configure, diagnose and troubleshoot.

The ComfortLink™ control is fully communicating and cable-ready for connection to the Carrier Comfort Network® (CCN) building management system. The control provides high-speed communications for remote monitoring via the Internet. Multiple units can be linked together (and to other ComfortLink control equipped units) using a 3-wire communication bus.

The ComfortLink control system is easy to access through the use of a unit-mounted display module. There is no need to bring a separate computer to this unit for start-up. Access to control menus is simplified by the ability to quickly select from 11 menus. A scrolling readout provides detailed explanations of control information. Only four, large, easy-to-use buttons are required to maneuver through the entire controls menu. The display readout is designed to be visible even in bright sunlight.

For added service flexibility, an accessory hand-held Navigator™ module is also available. This portable device has an extended communication cable that can be plugged into the unit's communication network at the main control box. The Navigator display provides the same menu structure, control access and display data as is available at the unit-mounted Scrolling Marquee display.

Scrolling Marquee — This device is the keypad interface used to access the control information, read sensor values, and test the unit. The Scrolling Marquee is located in the main control box and is standard on all units. The Scrolling Marquee display is a 4-key, 4-character, 16-segment LED (light-emitting diode) display module. The display also contains an Alarm Status LED. See Fig. 1. The display is easy to operate using 4 buttons and a group of 11 LEDs that indicate the following menu structures:

- Run Status
- Service Test
- Temperatures
- Pressures
- Set points
- Inputs
- Outputs
- Configuration
- Timeclock
- Operating Modes
- Alarms

Through the Scrolling Marquee, the user can access all of the inputs and outputs to check on their values and status, configure operating parameters plus evaluate the current decision status for operating modes. The control also includes an alarm history which can be accessed from the display. In addition, through the Scrolling Marquee, the user can access a built-in test routine that can be used at start-up commissioning and to diagnose operational problems with the unit.

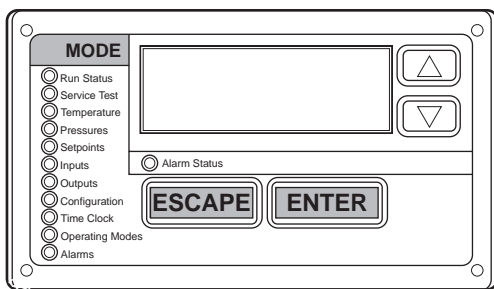

Fig. 1 — Scrolling Marquee

Accessory Navigator™ Display — The accessory hand-held Navigator display can be used with the 48/50PG units. See Fig. 2. The Navigator display operates the same way as the Scrolling Marquee device. The Navigator display is plugged into the LEN port on either TB2 or the ECB board.

Operation — All units are shipped from the factory with the Scrolling Marquee display, which is located in the main control box. See Fig. 1. In addition, the *ComfortLink™* control also supports the use of the handheld Navigator display.

Both displays provide the user with an interface to the *ComfortLink* control system. The displays have ▲ and ▼ arrow keys, an **ESCAPE** key and an **ENTER** key. These keys are used to navigate through the different levels of the display structure. The Navigator and the Scrolling Marquee operate in the same manner, except that the Navigator display has multiple lines of display and the Scrolling Marquee has a single line. All further discussions and examples in this document will be based on the Scrolling Marquee display. See Table 2 for the menu structure.

The four keys are used to navigate through the display structure, which is organized in a tiered mode structure. If the buttons have not been used for a period, the display will default

to the AUTO VIEW display category as shown under the RUN STATUS category. To show the top-level display, press the **ESCAPE** key until a blank display is shown. Then use the ▲ and ▼ arrow keys to scroll through the top-level categories. These are listed in Appendix A and will be indicated on the Scrolling Marquee by the LED next to each mode listed on the face of the display.

When a specific mode or sub-mode is located, push the **ENTER** key to enter the mode. Depending on the mode, there may be additional tiers. Continue to use the ▲ and ▼ keys and the **ENTER** keys until the desired display item is found. At any time, the user can move back a mode level by pressing the **ESCAPE** key. Once an item has been selected the display will flash showing the item, followed by the item value and then followed by the item units (if any).

Items in the Configuration and Service Test modes are password protected. The display will flash PASS and WORD when required. Use the **ENTER** and arrow keys to enter the four digits of the password. The default password is 1111.

Pressing the **ESCAPE** and **ENTER** keys simultaneously will scroll an expanded text description across the display indicating the full meaning of each display point. Pressing the **ESCAPE** and **ENTER** keys when the display is blank (MODE LED level) will return the display to its default menu of rotating AUTO VIEW display items. In addition, the password will need to be entered again before changes can be made.

Changing item values or testing outputs is accomplished in the same manner. Locate and display the desired item. If the display is in rotating auto-view, press the **ENTER** key to stop the display at the desired item. Press the **ENTER** key again so that the item value flashes. Use the arrow keys to change the value of state of an item and press the **ENTER** key to accept it. Press the **ESCAPE** key and the item, value or units display will resume. Repeat the process as required for other items.

Depending on the unit model, factory-installed options and field-installed accessories, some of the items in the various Mode categories may not apply.

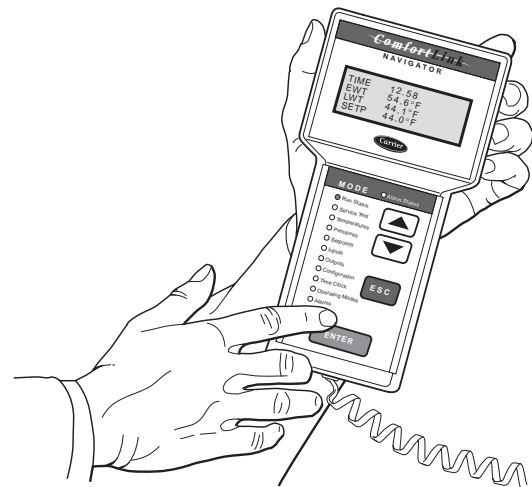

Fig. 2 — Accessory Navigator Display

System Pilot™ Device — The System Pilot (33PILOT-01) device is a component of Carrier’s 3V™ system and serves as a user-interface and configuration tool for all Carrier communicating devices. The System Pilot device can be used to install and commission a 3V zoning system, linkage compatible air source, universal controller, and all other devices operating on the Carrier communicating network.

Additionally, the System Pilot device can serve as a wall-mounted temperature sensor for space temperature measurement. The occupant can use the System Pilot device to change set points. A security feature is provided to limit access of features for unauthorized users. See Fig. 3 for System Pilot details.

CCN Tables and Display — In addition to the unit-mounted Scrolling Marquee display, the user can also access the same information through the CCN tables by using the Service tool or other CCN programs. Details on the CCN tables are summarized in Appendix A. The variable names used for the CCN tables and the Scrolling Marquee tables may be different and more items are displayed in the CCN tables. As a reference, the CCN variable names are included in the Scrolling Marquee tables and the Scrolling Marquee names are included in the local display tables in Appendix A.

Conventions Used in This Manual — The following conventions for discussing configuration points for the local display (Scrolling Marquee or Navigator™ accessory) will be used in this manual.

Point names will be written with the Mode name first, then any submodes, then the point name, each separated by an arrow symbol (→). Names will also be shown in bold and italics. As an example, the Thermostat Control Type which is located in the Configuration mode, and Unit sub-mode would be written as *Configuration* → *UNIT* → *T.CTL*.

This path name will show the user how to navigate through the local display to reach the desired configuration. The user would scroll through the modes and submodes using the ▲ and ▼ keys. The arrow symbol in the path name represents pressing **ENTER** to move into the next level of the menu structure.

When a value is included as part of the path name, it will be shown at the end of the path name after an equals sign. If the

value represents a configuration setting, an explanation will be shown in parenthesis after the value. As an example, *Configuration* → *UNIT* → *T.CTL = 1* (1 Stage Y1).

Pressing the **ESCAPE** and **ENTER** keys simultaneously will scroll an expanded text description of the point name across the display. The expanded description is shown in the local display tables but will not be shown with the path names in text.

The CCN point names are also referenced in the local display tables for users configuring the unit with CCN software instead of the local display. The CCN tables are located in Appendix A of this manual.

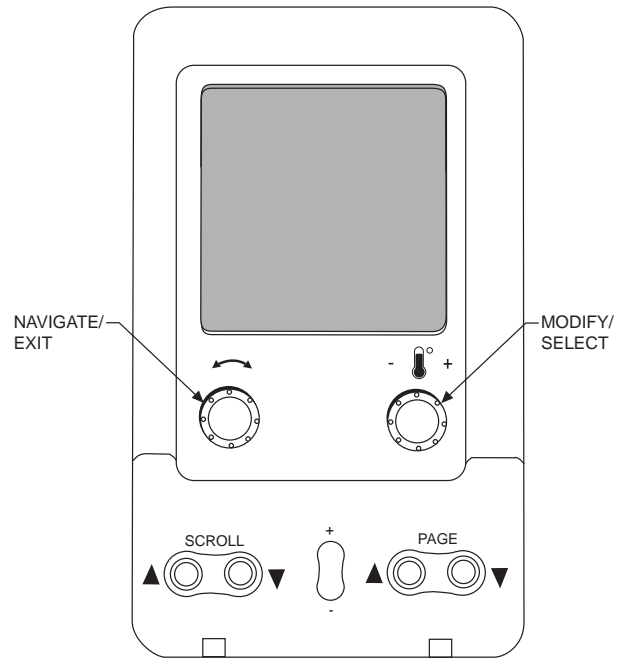

Fig. 3 — System Pilot User Interface

Table 2 — Scrolling Marquee Menu Display Structure

| RUN STATUS | SERVICE TEST | TEMPERATURES | PRESSURES | SETPOINTS | INPUTS | OUTPUTS | CONFIGURATION | TIME CLOCK | OPERATING MODES | ALARMS |
|--------------------------------------|--------------------------------------|---------------------------------------|-----------------------------------|---------------------------------------|------------------------------------|--------------------------------|--------------------------------------|--------------------------------------|-----------------------------------|--|
| Auto View of Run Status (VIEW) ↓ | Service Test Mode (TEST) ↓ | Air Temperatures (AIR.T) ↓ | Suction Pressure A (SSP.A) ↓ | Occupied Cool Setpoint (OCSP) ↓ | Thermostat Inputs (STAT) ↓ | Fan Outputs (FANS) ↓ | Display Configuration (DISP) ↓ | Time of Day (TIME) ↓ | Control Modes (MODE) ↓ | Reset All Current Alarms (R.CURR) ↓ |
| Software Version Numbers (VERS) ↓ | Test Independent Outputs (INDP) ↓ | Refrigerant Temperatures (REF.T) ↓ | Condenser Pressure A (SCP.A) ↓ | Unoccupied Cool Setpoint (UCSP) ↓ | General Inputs (GEN.I) ↓ | Cool Outputs (COOL) ↓ | Unit Configuration (UNIT) ↓ | Month, Date Day and Year (DATE) ↓ | Cool Mode Diagnostic (COOL) ↓ | Reset Alarm History (R.HIST) ↓ |
| Component Run Hours (HRS) ↓ | Test Fans (FANS) ↓ | | Suction Pressure B (SSP.B) ↓ | Occupied Heat Setpoint (OHSP) ↓ | Current Sensor Inputs (CS.IN) ↓ | Heat Outputs (HEAT) ↓ | Cooling Configuration (COOL) ↓ | Daylight Savings Time (DST) ↓ | Humidifier (HMZR) ↓ | Currently Active Alarms (CURR) ↓ |
| Component Starts (STRT) ↓ | Test Cooling (COOL) ↓ | | Condenser Pressure B (SCP.B) ↓ | Unoccupied Heat Setpoint (UHSP) ↓ | Air Quality Inputs (AIR.Q) ↓ | Economizer Outputs (ECON) ↓ | Humidifier Config. (HMZR) ↓ | Local Time Schedule (SCH.L) ↓ | Heat Mode Diagnostic (HEAT) ↓ | Alarm History (HIST) ↓ |
| Control Modes (MODE) ↓ | Test Humidifier (HMZR) ↓ | | Suction Pressure C (SSP.C) ↓ | Heat-Cool Setpoint (GAP) ↓ | | Alarm Relay (ALRM) ↓ | Heating Configuration (HEAT) ↓ | Local Holiday Schedules (HOL.L) ↓ | Economizer Diagnostic (ECON) ↓ | |
| Cooling Status (COOL) ↓ | Test Heating (HEAT) | | Condenser Pressure C (SCP.C) | SPT Offset Range (±) (STO.R) ↓ | | | Economizer Configuration (ECON) ↓ | | | |
| Heating Status (HEAT) ↓ | | | | Space RH Setpoint (RH.SP) ↓ | | | Air Quality Cfg. (AIR.Q) ↓ | | | |
| Economizer Status (ECON) | | | | Space RH Deadband (RH.DB) ↓ | | | Alarm Relay Config. (ALM.Ö) ↓ | | | |
| | | | | Reheat Heat SP Deadband (RH.HB) ↓ | | | Sensor Calibration (TRIM) ↓ | | | |
| | | | | Circuit A Lockout Temp (CA.LO) ↓ | | | CCN Configuration (CCN) | | | |
| | | | | Circuit B Lockout Temp (CB.LO) ↓ | | | | | | |
| | | | | Circuit C Lockout Temp (CC.LO) ↓ | | | | | | |
| | | | | Heating Lockout Temp (HT.LO) ↓ | | | | | | |
| | | | | Econo Cool Hi Temp Limit (EH.LO) ↓ | | | | | | |
| | | | | Econo Cool Lo Temp Limit (EL.LO) ↓ | | | | | | |
| | | | | Free Cool Low Temp Limit (FC.LO) ↓ | | | | | | |
| | | | | Low Cool SAT Set Point (LCSP) ↓ | | | | | | |
| | | | | High Cool SAT Set Point (HCSP) ↓ | | | | | | |
| | | | | Minimum SAT Upper Level (SAT.U) ↓ | | | | | | |
| | | | | Minimum SAT Lower Level (SAT.L) | | | | | | |

START-UP

Use the following information and Start-Up Checklist on page CL-1 to check out unit PRIOR to start-up.

Unit Preparation — Check that unit has been installed in accordance with these installation instructions and all applicable codes.

Compressor Mounting — Compressors are internally spring mounted. Do not loosen or remove compressor hold-down bolts.

Refrigerant Service Ports — Each independent refrigerant system has a total of 3 Schrader-type service gage ports per circuit. One port is located on the suction line, one on the compressor discharge line, and one on the liquid line. Be sure that caps on the ports are tight.

Crankcase Heater(s) — Crankcase heaters are energized as long as there is power to the unit and the compressor is not operating.

IMPORTANT: Unit power must be on for 24 hours prior to start-up. Otherwise, damage to compressor may result.

Compressor Rotation

⚠ CAUTION

Improper wiring will cause compressor stoppage and alarm. Correct wiring by switching leads as indicated below.

It is important to be certain the compressors are rotating in the proper direction. To determine whether or not compressors are rotating in the proper direction, use a phase-rotation meter on the unit input power to check for L1-L2-L3 or clockwise rotation or use the Service Test mode to energize a compressor. If the compressor is rotating in the wrong direction, the controls will stop the compressor and display alarm for “Circuit x Failure to Pressurize,” where x is the corresponding A or B compressor circuit.

NOTE: Indoor or outdoor fan rotation direction may not indicate proper input power phase sequence, as some 3-phase units use single-phase fan motors.

To correct the wrong compressor rotation direction, perform the following procedure:

1. Turn off power to the unit and lock out the power.
2. Switch any two of the incoming unit power leads.
3. Turn on power to the unit.
4. Verify corrected compressor rotation.

Internal Wiring — Check all electrical connections in unit control boxes; tighten as required.

Subcooler Heat Exchanger (SHX) — The subcooler heat exchanger adds approximately 10 to 15° F of subcooling to the system. Check all valves and TXV.

Evaporator Fan — Fan belt and variable pulleys are factory-installed. See Tables 3-26 for fan performance data. Be sure that fans rotate in the proper direction. See Tables 27 and 28 for air quantity limits. See Tables 29 and 30 for evaporator fan motor specifications. See Tables 31 and 32 for accessory FIOP static pressure. See Tables 33 and 34 for fan rpm at

various motor pulley settings. To alter fan performance, see Evaporator Fan Performance Adjustment section on page 87.

Condenser Fans and Motors — Condenser fans and motors are factory set. Refer to Condenser-Fan Adjustment section (page 88) as required.

Return-Air Filters — Check that correct filters are installed in filter tracks (see Physical Data table in Installation Instructions). Do not operate unit without return-air filters.

NOTE: For units with 4-in. filter option, units are shipped with standard 2-in. filters. To install 4-in. filters, the filter spacers must be removed.

Outdoor-Air Inlet Screens — Outdoor-air inlet screens must be in place before operating unit.

Gas Heat (48PG Only) — Verify gas pressures before turning on heat as follows:

1. Turn off field-supplied manual gas stop, located external to unit.
2. Connect pressure gage to supply gas tap, located on field-supplied manual shutoff valve (see Fig. 4).
3. Connect pressure gage to manifold pressure tap.
4. Turn on field-supplied manual gas stop. Enter Service Test mode by setting TEST to “YES” using the Scrolling Marquee display. Temporarily install the jumper wire between “R” and “W1” on TB2. Use the Service Test feature to set HT.1 to ON (first stage of heat) using the Scrolling Marquee.
5. After the unit has run for several minutes, verify the supply gas pressure is between 5.5 in. wg to 13.0 in. wg, and the manifold pressure is 2.95 in. wg on horizontal discharge applications and 3.00 on vertical discharge applications. If manifold pressure must be adjusted, refer to Gas Valve Adjustment section.
NOTE: Supply gas pressure must not exceed 13.0 in. wg.
6. Set HT.1 to OFF using Scrolling Marquee.
7. Remove jumper wire if the unit will be operating under thermostat mode. The jumper must remain if a space temperature sensor (T-55, T-56, or T-58) will control the unit.
8. Exit Service Test mode by setting TEST to “NO” using the Scrolling Marquee.

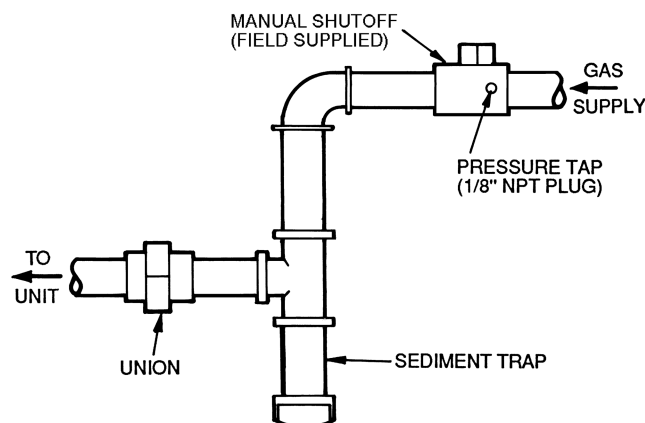

Fig. 4 — Field Gas Piping

Orifice Change (48PG Only) — This unit is factory assembled for heating operation using natural gas at an elevation from sea level to 2000 ft.

Use accessory high altitude kit when installing this unit at an elevation of 2000 to 7000 ft. For elevations above 7000 ft, refer to High Altitude section on page 90 to identify the correct orifice size for the elevation. Purchase these orifices from your local Carrier dealer. Follow instructions in accessory Installation Instructions to install the correct orifices.

Use accessory LP (liquid propane) gas conversion kit when converting this unit for use with LP fuel usage for elevations up to 7000 ft. For elevations above 7000 ft, refer to High Altitude section on page 90 to identify the correct orifice size for the elevation. Purchase these orifices from your local Carrier dealer. Follow instructions in accessory Installation Instructions to install the correct orifices.

Power Supply — All 208/230-v units are factory wired for 230-v power supply. If the 208/230-v unit is to be

connected to a 208-v power supply, the transformers (TRAN1, TRAN2 and TRAN3) must be rewired by moving the wire from the 230-volt connection and moving to the 200-volt terminal on the primary side of the transformer. Refer to unit label diagram for additional information.

Air Baffles — The 48/50PG units with Humid-MiZer™ option are equipped with Motormaster® control to maintain adequate discharge pressure for proper unit operation during low ambient operation. Field-fabricated and installed wind baffles may be required. See Optional Humid-MiZer Dehumidification System section on page 45.

Accessory Installation — Check to make sure that all accessories including space thermostats and sensors have been installed and wired as required by the instructions and unit wiring diagrams.

Table 3 — Fan Performance — 48PGD020 — Vertical Supply/Return Units

| AIRFLOW (Cfm) | AVAILABLE EXTERNAL STATIC PRESSURE (in. wg) | | | | | | | | | |
|---------------|---|-------------|------------|-------------|------------|-------------|--------|------|------------|-------------|
| | 0.2 | | 0.4 | | 0.6 | | 0.8 | | 1.0 | |
| | Rpm | Bhp | Rpm | Bhp | Rpm | Bhp | Rpm | Bhp | Rpm | Bhp |
| 5000 | 590 | 1.47 | 663 | 1.74 | 727 | 2.01 | 786 | 2.26 | 840 | 2.52 |
| 5500 | 633 | 1.82 | 703 | 2.11 | 764 | 2.40 | 820 | 2.67 | A 872 | 2.94 |
| 6000 | 677 | 2.21 | 744 | 2.53 | A 803 | 2.84 | A 857 | 3.13 | 907 | 3.42 |
| 6500 | 722 | 2.67 | A 786 | 3.01 | 842 | 3.33 | 894 | 3.64 | 942 | 3.95 |
| 7000 | A 767 | 3.17 | 828 | 3.53 | 883 | 3.88 | 933 | 4.21 | B 979 | 4.53 |
| 7500 | 813 | 3.74 | 871 | 4.12 | 924 | 4.48 | B 972 | 4.83 | 1017 | 5.18 |
| 8000 | 859 | 4.36 | 915 | 4.77 | B 966 | 5.15 | 1012 | 5.52 | 1056 | 5.88 |
| 8500 | 906 | 5.05 | B 959 | 5.47 | C 1008 | 5.87 | C 1053 | 6.26 | C 1096 | 6.64 |
| 9000 | C 952 | 5.81 | C 1004 | 6.25 | C 1051 | 6.67 | C 1095 | 7.07 | 1136 | 7.47 |

| AIRFLOW (Cfm) | AVAILABLE EXTERNAL STATIC PRESSURE (in. wg) | | | | | | | | | |
|---------------|---|------|------------|-------------|--------|------|--------|------|-------------|-------------|
| | 1.2 | | 1.4 | | 1.6 | | 1.8 | | 2.0 | |
| | Rpm | Bhp | Rpm | Bhp | Rpm | Bhp | Rpm | Bhp | Rpm | Bhp |
| 5000 | A 891 | 2.77 | 940 | 3.02 | 987 | 3.27 | 1032 | 3.52 | 1076 | 3.77 |
| 5500 | A 921 | 3.21 | 968 | 3.48 | 1014 | 3.74 | B 1057 | 4.01 | B 1099 | 4.27 |
| 6000 | 954 | 3.70 | B 999 | 3.99 | B 1042 | 4.27 | B 1084 | 4.55 | B 1125 | 4.83 |
| 6500 | B 988 | 4.25 | B 1032 | 4.55 | 1073 | 4.85 | 1114 | 5.14 | 1153 | 5.44 |
| 7000 | B 1024 | 4.85 | 1066 | 5.17 | 1106 | 5.48 | C 1145 | 5.79 | 1183 | 6.10 |
| 7500 | 1060 | 5.51 | 1101 | 5.84 | C 1140 | 6.17 | 1178 | 6.50 | D 1215 | 6.82 |
| 8000 | 1098 | 6.23 | C 1138 | 6.58 | 1176 | 6.92 | D 1213 | 7.26 | D 1249 | 7.60 |
| 8500 | C 1137 | 7.01 | 1175 | 7.38 | D 1212 | 7.74 | D 1248 | 8.09 | 1283 | 8.45 |
| 9000 | 1176 | 7.86 | D 1214 | 8.24 | 1250 | 8.61 | 1285 | 8.99 | 1319 | 9.36 |

LEGEND

Bhp — Brake Horsepower Input to Fan

Boldface indicates field-supplied motor/drive required.

NOTES:

- Motor drive ranges:
 - (A) Low Range: 685-939, 4.26 Bhp (208/230 and 460-v), 751-954, 5.75 Bhp (575-v)
 - (B) Mid-Low Range: 949-1206, 5.75 Bhp
 - (C) Mid High Range: 941-1176, 8.63 Bhp
 - (D) High Range: 1014-1297, 11.50 Bhp
 All other rpms require field-supplied motor or drive.
- See page 30 for general fan performance notes.

Table 4 — Fan Performance — 48PGE20 — Vertical Supply/Return Units

| AIRFLOW (Cfm) | AVAILABLE EXTERNAL STATIC PRESSURE (in. wg) | | | | | | | | | |
|------------------|---|-------------|---------------|-------------|---------------|-------------|---------------|------|---------------|------|
| | 0.2 | | 0.4 | | 0.6 | | 0.8 | | 1.0 | |
| | Rpm | Bhp | Rpm | Bhp | Rpm | Bhp | Rpm | Bhp | Rpm | Bhp |
| 5000 | 607 | 1.53 | 677 | 1.80 | 740 | 2.06 | 797 | 2.31 | 850 | 2.57 |
| 5500 | 652 | 1.90 | 719 | 2.19 | 779 | 2.47 | A 833 | 2.74 | A 884 | 3.01 |
| 6000 | 699 | 2.32 | A 763 | 2.63 | A 819 | 2.93 | A 872 | 3.22 | A 921 | 3.50 |
| 6500 | A 746 | 2.79 | A 807 | 3.12 | 861 | 3.44 | 911 | 3.75 | 958 | 4.05 |
| 7000 | 794 | 3.33 | 851 | 3.68 | 904 | 4.02 | 952 | 4.34 | B 998 | 4.66 |
| 7500 | 842 | 3.93 | 897 | 4.30 | 947 | 4.65 | B 994 | 5.00 | 1038 | 5.33 |
| 8000 | 891 | 4.59 | 943 | 4.98 | B 991 | 5.35 | 1036 | 5.71 | 1079 | 6.07 |
| 8500 | C 940 | 5.32 | B 990 | 5.72 | C 1036 | 6.11 | C 1080 | 6.49 | C 1121 | 6.87 |
| 9000 | 990 | 6.12 | C 1037 | 6.54 | 1082 | 6.95 | C 1124 | 7.35 | 1163 | 7.73 |

| AIRFLOW (Cfm) | AVAILABLE EXTERNAL STATIC PRESSURE (in. wg) | | | | | | | | | |
|------------------|---|------|---------------|------|---------------|------|---------------|-------------|---------------|-------------|
| | 1.2 | | 1.4 | | 1.6 | | 1.8 | | 2.0 | |
| | Rpm | Bhp | Rpm | Bhp | Rpm | Bhp | Rpm | Bhp | Rpm | Bhp |
| 5000 | A 900 | 2.82 | 949 | 3.06 | 995 | 3.31 | 1040 | 3.56 | 1083 | 3.81 |
| 5500 | A 933 | 3.27 | 979 | 3.54 | 1023 | 3.80 | B 1066 | 4.06 | B 1108 | 4.33 |
| 6000 | 967 | 3.79 | B 1011 | 4.07 | B 1054 | 4.35 | B 1095 | 4.62 | B 1135 | 4.90 |
| 6500 | B 1003 | 4.35 | 1046 | 4.65 | 1087 | 4.94 | 1127 | 5.24 | 1165 | 5.53 |
| 7000 | B 1041 | 4.98 | 1082 | 5.29 | 1122 | 5.60 | C 1160 | 5.91 | 1197 | 6.22 |
| 7500 | 1079 | 5.67 | C 1119 | 5.99 | C 1158 | 6.32 | 1195 | 6.64 | D 1231 | 6.96 |
| 8000 | C 1119 | 6.42 | C 1158 | 6.76 | 1195 | 7.10 | D 1231 | 7.44 | 1267 | 7.78 |
| 8500 | C 1160 | 7.23 | D 1198 | 7.59 | D 1234 | 7.95 | 1269 | 8.30 | 1303 | 8.65 |
| 9000 | D 1202 | 8.12 | 1238 | 8.49 | 1273 | 8.87 | 1308 | 9.23 | 1341 | 9.60 |

LEGEND

Bhp — Brake Horsepower Input to Fan

Boldface indicates field-supplied motor/drive required.

NOTES:

- Motor drive ranges:
(A) Low Range: 685-939, 4.26 Bhp (208/230 and 460-v), 751-954, 5.75 Bhp (575-v)
(B) Mid-Low Range: 949-1206, 5.75 Bhp
(C) Mid High Range: 941-1176, 8.63 Bhp
(D) High Range: 1014-1297, 11.50 Bhp

All other rpms require field-supplied motor or drive.

- See page 30 for general fan performance notes.

Table 5 — Fan Performance — 48PGF20 — Vertical Supply/Return Units

| AIRFLOW (Cfm) | AVAILABLE EXTERNAL STATIC PRESSURE (in. wg) | | | | | | | | | |
|------------------|---|-------------|---------------|-------------|---------------|-------------|---------------|------|---------------|------|
| | 0.2 | | 0.4 | | 0.6 | | 0.8 | | 1.0 | |
| | Rpm | Bhp | Rpm | Bhp | Rpm | Bhp | Rpm | Bhp | Rpm | Bhp |
| 5000 | 607 | 1.53 | 677 | 1.80 | 740 | 2.06 | 797 | 2.31 | 850 | 2.57 |
| 5500 | 652 | 1.90 | 719 | 2.19 | 779 | 2.47 | A 833 | 2.74 | A 884 | 3.01 |
| 6000 | 699 | 2.32 | A 763 | 2.63 | A 819 | 2.93 | A 872 | 3.22 | A 921 | 3.50 |
| 6500 | A 746 | 2.79 | A 807 | 3.12 | 861 | 3.44 | 911 | 3.75 | 958 | 4.05 |
| 7000 | 794 | 3.33 | 851 | 3.68 | 904 | 4.02 | 952 | 4.34 | B 998 | 4.66 |
| 7500 | 842 | 3.93 | 897 | 4.30 | 947 | 4.65 | B 994 | 5.00 | 1038 | 5.33 |
| 8000 | 891 | 4.59 | 943 | 4.98 | B 991 | 5.35 | 1036 | 5.71 | 1079 | 6.07 |
| 8500 | 940 | 5.32 | B 990 | 5.72 | C 1036 | 6.11 | 1080 | 6.49 | C 1121 | 6.87 |
| 9000 | C 990 | 6.12 | C 1037 | 6.54 | C 1082 | 6.95 | C 1124 | 7.35 | 1163 | 7.73 |

| AIRFLOW (Cfm) | AVAILABLE EXTERNAL STATIC PRESSURE (in. wg) | | | | | | | | | |
|------------------|---|------|---------------|------|---------------|------|---------------|-------------|---------------|-------------|
| | 1.2 | | 1.4 | | 1.6 | | 1.8 | | 2.0 | |
| | Rpm | Bhp | Rpm | Bhp | Rpm | Bhp | Rpm | Bhp | Rpm | Bhp |
| 5000 | A 900 | 2.82 | 949 | 3.06 | 995 | 3.31 | 1040 | 3.56 | 1083 | 3.81 |
| 5500 | A 933 | 3.27 | 979 | 3.54 | 1023 | 3.80 | B 1066 | 4.06 | B 1108 | 4.33 |
| 6000 | 967 | 3.79 | B 1011 | 4.07 | B 1054 | 4.35 | B 1095 | 4.62 | B 1135 | 4.90 |
| 6500 | B 1003 | 4.35 | 1046 | 4.65 | 1087 | 4.94 | 1127 | 5.24 | 1165 | 5.53 |
| 7000 | B 1041 | 4.98 | 1082 | 5.29 | 1122 | 5.60 | C 1160 | 5.91 | 1197 | 6.22 |
| 7500 | 1079 | 5.67 | 1119 | 5.99 | C 1158 | 6.32 | 1195 | 6.64 | D 1231 | 6.96 |
| 8000 | C 1119 | 6.42 | C 1158 | 6.76 | 1195 | 7.10 | D 1231 | 7.44 | 1267 | 7.78 |
| 8500 | C 1160 | 7.23 | D 1198 | 7.59 | D 1234 | 7.95 | 1269 | 8.30 | 1303 | 8.65 |
| 9000 | D 1202 | 8.12 | D 1238 | 8.49 | 1273 | 8.87 | 1308 | 9.23 | 1341 | 9.60 |

LEGEND

Bhp — Brake Horsepower Input to Fan

Boldface indicates field-supplied motor/drive required.

NOTES:

- Motor drive ranges:
(A) Low Range: 685-939, 4.26 Bhp (208/230 and 460-v), 751-954, 5.75 Bhp (575-v)
(B) Mid-Low Range: 949-1206, 5.75 Bhp
(C) Mid High Range: 941-1176, 8.63 Bhp
(D) High Range: 1014-1297, 11.50 Bhp

All other rpms require field-supplied motor or drive.

- See page 30 for general fan performance notes.

Table 6 — Fan Performance — 48PGD24 — Vertical Supply/Return Units

| AIRFLOW (Cfm) | AVAILABLE EXTERNAL STATIC PRESSURE (in. wg) | | | | | | | | | |
|------------------|---|-------------|------------|-------------|------------|-------------|--------|------|------------|-------------|
| | 0.2 | | 0.4 | | 0.6 | | 0.8 | | 1.0 | |
| | Rpm | Bhp | Rpm | Bhp | Rpm | Bhp | Rpm | Bhp | Rpm | Bhp |
| 5,500 | 633 | 1.82 | 703 | 2.11 | 764 | 2.40 | 820 | 2.67 | A 872 | 2.94 |
| 6,000 | 677 | 2.21 | 744 | 2.53 | A 803 | 2.84 | A 857 | 3.13 | 907 | 3.42 |
| 6,500 | 722 | 2.67 | A 786 | 3.01 | A 842 | 3.33 | A 894 | 3.64 | 942 | 3.95 |
| 7,000 | A 767 | 3.17 | 828 | 3.53 | 883 | 3.88 | 933 | 4.21 | 979 | 4.53 |
| 7,500 | 813 | 3.74 | 871 | 4.12 | 924 | 4.48 | B 972 | 4.83 | B 1017 | 5.18 |
| 8,000 | 859 | 4.36 | 915 | 4.77 | B 966 | 5.15 | B 1012 | 5.52 | 1056 | 5.88 |
| 8,500 | 906 | 5.05 | B 959 | 5.47 | 1008 | 5.87 | 1053 | 6.26 | C 1096 | 6.64 |
| 9,000 | 952 | 5.81 | 1004 | 6.25 | C 1051 | 6.67 | C 1095 | 7.07 | 1136 | 7.47 |
| 9,500 | C 999 | 6.63 | C 1049 | 7.09 | C 1094 | 7.53 | C 1137 | 7.95 | 1177 | 8.36 |
| 10,000 | 1047 | 7.53 | 1094 | 8.00 | 1138 | 8.46 | D 1180 | 8.90 | D 1219 | 9.33 |

| AIRFLOW (Cfm) | AVAILABLE EXTERNAL STATIC PRESSURE (in. wg) | | | | | | | | | |
|------------------|---|------|--------|-------|-------------|--------------|-------------|--------------|-------------|--------------|
| | 1.2 | | 1.4 | | 1.6 | | 1.8 | | 2.0 | |
| | Rpm | Bhp | Rpm | Bhp | Rpm | Bhp | Rpm | Bhp | Rpm | Bhp |
| 5,500 | A 921 | 3.21 | 968 | 3.48 | 1014 | 3.74 | 1057 | 4.01 | 1099 | 4.27 |
| 6,000 | 954 | 3.70 | 999 | 3.99 | 1042 | 4.27 | B 1084 | 4.55 | B 1125 | 4.83 |
| 6,500 | 988 | 4.25 | B 1032 | 4.55 | B 1073 | 4.85 | 1114 | 5.14 | 1153 | 5.44 |
| 7,000 | B 1024 | 4.85 | 1066 | 5.17 | 1106 | 5.48 | C 1145 | 5.79 | 1183 | 6.10 |
| 7,500 | 1060 | 5.51 | 1101 | 5.84 | C 1140 | 6.17 | 1178 | 6.50 | D 1215 | 6.82 |
| 8,000 | 1098 | 6.23 | C 1138 | 6.58 | 1176 | 6.92 | D 1213 | 7.26 | D 1249 | 7.60 |
| 8,500 | C 1137 | 7.01 | 1175 | 7.38 | 1212 | 7.74 | D 1248 | 8.09 | 1283 | 8.45 |
| 9,000 | 1176 | 7.86 | 1214 | 8.24 | D 1250 | 8.61 | 1285 | 8.99 | 1319 | 9.36 |
| 9,500 | 1216 | 8.77 | D 1253 | 9.17 | 1288 | 9.56 | 1322 | 9.95 | 1355 | 10.33 |
| 10,000 | D 1256 | 9.75 | 1292 | 10.16 | 1327 | 10.57 | 1360 | 10.98 | 1393 | 11.38 |

LEGEND

Bhp — Brake Horsepower Input to Fan

Boldface indicates field-supplied motor/drive required.

NOTES:

1. Motor drive ranges:

- (A) Low Range: 685-939, 4.26 Bhp (208/230 and 460-v), 751-954, 5.75 Bhp (575-v)
- (B) Mid-Low Range: 949-1206, 5.75 Bhp
- (C) Mid High Range: 941-1176, 8.63 Bhp
- (D) High Range: 1014-1297, 11.50 Bhp

All other rpms require field-supplied motor or drive.

2. See page 30 for general fan performance notes.

Table 7 — Fan Performance — 48PGE24 — Vertical Supply/Return Units

| AIRFLOW (Cfm) | AVAILABLE EXTERNAL STATIC PRESSURE (in. wg) | | | | | | | | | |
|------------------|---|-------------|------------|-------------|------------|-------------|--------|------|--------|------|
| | 0.2 | | 0.4 | | 0.6 | | 0.8 | | 1.0 | |
| | Rpm | Bhp | Rpm | Bhp | Rpm | Bhp | Rpm | Bhp | Rpm | Bhp |
| 5,500 | 652 | 1.90 | 719 | 2.19 | 779 | 2.47 | 833 | 2.74 | A 884 | 3.01 |
| 6,000 | 699 | 2.32 | A 763 | 2.63 | A 819 | 2.93 | A 872 | 3.22 | A 921 | 3.50 |
| 6,500 | 746 | 2.79 | 807 | 3.12 | A 861 | 3.44 | 911 | 3.75 | 958 | 4.05 |
| 7,000 | 794 | 3.33 | 851 | 3.68 | 904 | 4.02 | 952 | 4.34 | B 998 | 4.66 |
| 7,500 | 842 | 3.93 | 897 | 4.30 | 947 | 4.65 | B 994 | 5.00 | 1038 | 5.33 |
| 8,000 | 891 | 4.59 | 943 | 4.98 | B 991 | 5.35 | 1036 | 5.71 | 1079 | 6.07 |
| 8,500 | 940 | 5.32 | B 990 | 5.72 | 1036 | 6.11 | 1080 | 6.49 | C 1121 | 6.87 |
| 9,000 | 990 | 6.12 | 1037 | 6.54 | C 1082 | 6.95 | C 1124 | 7.35 | 1163 | 7.73 |
| 9,500 | 1039 | 7.00 | C 1085 | 7.43 | 1128 | 7.85 | 1168 | 8.27 | 1207 | 8.67 |
| 10,000 | 1089 | 7.95 | 1133 | 8.40 | D 1174 | 8.83 | D 1213 | 9.26 | D 1251 | 9.69 |

| AIRFLOW (Cfm) | AVAILABLE EXTERNAL STATIC PRESSURE (in. wg) | | | | | | | | | |
|------------------|---|-------|-------------|--------------|-------------|--------------|-------------|--------------|-------------|--------------|
| | 1.2 | | 1.4 | | 1.6 | | 1.8 | | 2.0 | |
| | Rpm | Bhp | Rpm | Bhp | Rpm | Bhp | Rpm | Bhp | Rpm | Bhp |
| 5,500 | A 933 | 3.27 | 979 | 3.54 | 1023 | 3.80 | 1066 | 4.06 | 1108 | 4.33 |
| 6,000 | 967 | 3.79 | 1011 | 4.07 | 1054 | 4.35 | B 1095 | 4.62 | B 1135 | 4.90 |
| 6,500 | 1003 | 4.35 | B 1046 | 4.65 | B 1087 | 4.94 | 1127 | 5.24 | 1165 | 5.53 |
| 7,000 | B 1041 | 4.98 | 1082 | 5.29 | 1122 | 5.60 | C 1160 | 5.91 | 1197 | 6.22 |
| 7,500 | 1079 | 5.67 | 1119 | 5.99 | C 1158 | 6.32 | 1195 | 6.64 | D 1231 | 6.96 |
| 8,000 | C 1119 | 6.42 | 1158 | 6.76 | 1195 | 7.10 | D 1231 | 7.44 | 1267 | 7.78 |
| 8,500 | 1160 | 7.23 | 1198 | 7.59 | D 1234 | 7.95 | 1269 | 8.30 | 1303 | 8.65 |
| 9,000 | 1202 | 8.12 | D 1238 | 8.49 | 1273 | 8.87 | 1308 | 9.23 | 1341 | 9.60 |
| 9,500 | D 1244 | 9.07 | 1279 | 9.46 | 1314 | 9.85 | 1347 | 10.24 | 1379 | 10.62 |
| 10,000 | 1287 | 10.10 | 1321 | 10.51 | 1355 | 10.91 | 1387 | 11.31 | — | — |

LEGEND

Bhp — Brake Horsepower Input to Fan

Boldface indicates field-supplied motor/drive required.

NOTES:

- Motor drive ranges:
(A) Low Range: 685-939, 4.26 Bhp (208/230 and 460-v), 751-954, 5.75 Bhp (575-v)
(B) Mid-Low Range: 949-1206, 5.75 Bhp
(C) Mid High Range: 941-1176, 8.63 Bhp
(D) High Range: 1014-1297, 11.50 Bhp
 All other rpms require field-supplied motor or drive.
- See page 30 for general fan performance notes.

Table 8 — Fan Performance — 48PGF24 — Vertical Supply/Return Units

| AIRFLOW (Cfm) | AVAILABLE EXTERNAL STATIC PRESSURE (in. wg) | | | | | | | | | |
|------------------|---|-------------|------------|-------------|------------|-------------|--------|------|--------|------|
| | 0.2 | | 0.4 | | 0.6 | | 0.8 | | 1.0 | |
| | Rpm | Bhp | Rpm | Bhp | Rpm | Bhp | Rpm | Bhp | Rpm | Bhp |
| 5,500 | 652 | 1.90 | 719 | 2.19 | 779 | 2.47 | 833 | 2.74 | A 884 | 3.01 |
| 6,000 | 699 | 2.32 | A 763 | 2.63 | A 819 | 2.93 | A 872 | 3.22 | A 921 | 3.50 |
| 6,500 | 746 | 2.79 | 807 | 3.12 | A 861 | 3.44 | 911 | 3.75 | 958 | 4.05 |
| 7,000 | 794 | 3.33 | 851 | 3.68 | 904 | 4.02 | 952 | 4.34 | B 998 | 4.66 |
| 7,500 | 842 | 3.93 | 897 | 4.30 | 947 | 4.65 | B 994 | 5.00 | 1038 | 5.33 |
| 8,000 | 891 | 4.59 | 943 | 4.98 | B 991 | 5.35 | 1036 | 5.71 | 1079 | 6.07 |
| 8,500 | 940 | 5.32 | B 990 | 5.72 | 1036 | 6.11 | 1080 | 6.49 | C 1121 | 6.87 |
| 9,000 | 990 | 6.12 | 1037 | 6.54 | C 1082 | 6.95 | C 1124 | 7.35 | 1163 | 7.73 |
| 9,500 | C 1039 | 7.00 | C 1085 | 7.43 | 1128 | 7.85 | C 1168 | 8.27 | 1207 | 8.67 |
| 10,000 | 1089 | 7.95 | 1133 | 8.40 | D 1174 | 8.83 | D 1213 | 9.26 | D 1251 | 9.69 |

| AIRFLOW (Cfm) | AVAILABLE EXTERNAL STATIC PRESSURE (in. wg) | | | | | | | | | |
|------------------|---|-------|-------------|--------------|-------------|--------------|-------------|--------------|-------------|--------------|
| | 1.2 | | 1.4 | | 1.6 | | 1.8 | | 2.0 | |
| | Rpm | Bhp | Rpm | Bhp | Rpm | Bhp | Rpm | Bhp | Rpm | Bhp |
| 5,500 | A 933 | 3.27 | 979 | 3.54 | 1023 | 3.80 | 1066 | 4.06 | 1108 | 4.33 |
| 6,000 | 967 | 3.79 | 1011 | 4.07 | 1054 | 4.35 | B 1095 | 4.62 | B 1135 | 4.90 |
| 6,500 | 1003 | 4.35 | B 1046 | 4.65 | B 1087 | 4.94 | 1127 | 5.24 | 1165 | 5.53 |
| 7,000 | B 1041 | 4.98 | 1082 | 5.29 | 1122 | 5.60 | C 1160 | 5.91 | 1197 | 6.22 |
| 7,500 | 1079 | 5.67 | 1119 | 5.99 | C 1158 | 6.32 | 1195 | 6.64 | D 1231 | 6.96 |
| 8,000 | C 1119 | 6.42 | 1158 | 6.76 | 1195 | 7.10 | D 1231 | 7.44 | 1267 | 7.78 |
| 8,500 | 1160 | 7.23 | 1198 | 7.59 | D 1234 | 7.95 | 1269 | 8.30 | 1303 | 8.65 |
| 9,000 | 1202 | 8.12 | D 1238 | 8.49 | 1273 | 8.87 | 1308 | 9.23 | 1341 | 9.60 |
| 9,500 | D 1244 | 9.07 | 1279 | 9.46 | 1314 | 9.85 | 1347 | 10.24 | 1379 | 10.62 |
| 10,000 | 1287 | 10.10 | 1321 | 10.51 | 1355 | 10.91 | 1387 | 11.31 | — | — |

LEGEND

Bhp — Brake Horsepower Input to Fan

Boldface indicates field-supplied motor/drive required.

NOTES:

1. Motor drive ranges:

(A) Low Range: 685-939, 4.26 Bhp (208/230 and 460-v), 751-954, 5.75 Bhp (575-v)

(B) Mid-Low Range: 949-1206, 5.75 Bhp

(C) Mid High Range: 941-1176, 8.63 Bhp

(D) High Range: 1014-1297, 11.50 Bhp

All other rpms require field-supplied motor or drive.

2. See page 30 for general fan performance notes.

Table 9 — Fan Performance — 48PGD28 — Vertical Supply/Return Units

| AIRFLOW (Cfm) | AVAILABLE EXTERNAL STATIC PRESSURE (in. wg) | | | | | | | | | |
|------------------|---|--------------|-------------|--------------|-------------|--------------|-------------|--------------|-------------|--------------|
| | 0.2 | | 0.4 | | 0.6 | | 0.8 | | 1.0 | |
| | Rpm | Bhp | Rpm | Bhp | Rpm | Bhp | Rpm | Bhp | Rpm | Bhp |
| 6,500 | 750 | 2.84 | A 806 | 3.18 | A 854 | 3.49 | 898 | 3.79 | B 943 | 4.12 |
| 7,000 | A 797 | 3.38 | 853 | 3.77 | 899 | 4.09 | B 941 | 4.41 | B 982 | 4.74 |
| 7,500 | 845 | 3.99 | B 900 | 4.42 | B 945 | 4.76 | 985 | 5.09 | 1024 | 5.43 |
| 8,000 | B 892 | 4.65 | 948 | 5.13 | 991 | 5.51 | 1030 | 5.86 | 1067 | 6.20 |
| 8,500 | 939 | 5.38 | 995 | 5.91 | 1038 | 6.32 | C 1076 | 6.69 | C 1112 | 7.05 |
| 9,000 | 986 | 6.17 | C 1042 | 6.76 | C 1085 | 7.21 | C 1122 | 7.60 | 1157 | 7.98 |
| 9,500 | C 1033 | 7.03 | 1090 | 7.69 | 1132 | 8.17 | 1169 | 8.59 | 1203 | 8.99 |
| 10,000 | 1079 | 7.95 | 1137 | 8.68 | D 1180 | 9.21 | D 1216 | 9.66 | D 1249 | 10.08 |
| 10,500 | 1126 | 8.94 | D 1184 | 9.75 | 1227 | 10.33 | D 1263 | 10.81 | D 1296 | 11.25 |
| 11,000 | D 1172 | 10.00 | 1232 | 10.90 | 1274 | 11.52 | 1310 | 12.04 | 1342 | 12.51 |
| 11,500 | 1219 | 11.13 | 1279 | 12.12 | 1322 | 12.80 | 1357 | 13.35 | — | — |
| 12,000 | 1265 | 12.34 | 1326 | 13.42 | — | — | — | — | — | — |
| 12,500 | 1311 | 13.63 | — | — | — | — | — | — | — | — |

| AIRFLOW (Cfm) | AVAILABLE EXTERNAL STATIC PRESSURE (in. wg) | | | | | | | | | |
|------------------|---|--------------|-------------|--------------|-------------|--------------|-------------|--------------|-------------|--------------|
| | 1.2 | | 1.4 | | 1.6 | | 1.8 | | 2.0 | |
| | Rpm | Bhp | Rpm | Bhp | Rpm | Bhp | Rpm | Bhp | Rpm | Bhp |
| 6,500 | B 988 | 4.49 | 1035 | 4.89 | 1082 | 5.33 | C 1130 | 5.81 | 1177 | 6.32 |
| 7,000 | 1024 | 5.09 | C 1066 | 5.48 | C 1109 | 5.90 | 1153 | 6.35 | D 1197 | 6.85 |
| 7,500 | C 1063 | 5.78 | 1101 | 6.15 | C 1141 | 6.56 | 1181 | 6.99 | 1222 | 7.46 |
| 8,000 | 1104 | 6.55 | 1140 | 6.92 | 1176 | 7.32 | D 1213 | 7.74 | 1251 | 8.19 |
| 8,500 | 1146 | 7.41 | 1180 | 7.78 | 1214 | 8.17 | 1249 | 8.58 | 1283 | 9.01 |
| 9,000 | 1190 | 8.35 | D 1222 | 8.73 | D 1255 | 9.11 | 1287 | 9.52 | 1319 | 9.94 |
| 9,500 | D 1235 | 9.37 | 1266 | 9.76 | 1296 | 10.15 | 1327 | 10.55 | 1357 | 10.97 |
| 10,000 | 1280 | 10.48 | 1310 | 10.88 | 1340 | 11.28 | 1369 | 11.68 | 1398 | 12.10 |
| 10,500 | 1326 | 11.67 | 1355 | 12.08 | 1384 | 12.49 | — | — | — | — |
| 11,000 | 1372 | 12.95 | — | — | — | — | — | — | — | — |
| 11,500 | — | — | — | — | — | — | — | — | — | — |
| 12,000 | — | — | — | — | — | — | — | — | — | — |
| 12,500 | — | — | — | — | — | — | — | — | — | — |

LEGEND

Bhp — Brake Horsepower Input to Fan

Boldface indicates field-supplied motor/drive required.

NOTES:

1. Motor drive ranges:

- (A) Low Range: 687-873, 5.75 Bhp
- (B) Mid-Low Range: 805-1007, 5.75 Bhp
- (C) Mid High Range: 941-1176, 8.63 Bhp
- (D) High Range: 1014-1297, 11.50 Bhp

All other rpms require field-supplied motor or drive.

2. See page 30 for general fan performance notes.

Table 10 — Fan Performance — 48PGE28 — Vertical Supply/Return Units

| AIRFLOW (Cfm) | AVAILABLE EXTERNAL STATIC PRESSURE (in. wg) | | | | | | | | | |
|------------------|---|--------------|-------------|--------------|-------------|--------------|-------------|--------------|-------------|--------------|
| | 0.2 | | 0.4 | | 0.6 | | 0.8 | | 1.0 | |
| | Rpm | Bhp | Rpm | Bhp | Rpm | Bhp | Rpm | Bhp | Rpm | Bhp |
| 6,500 | A 775 | 2.99 | A 825 | 3.30 | A 871 | 3.60 | 915 | 3.91 | B 959 | 4.25 |
| 7,000 | 826 | 3.58 | 875 | 3.92 | 918 | 4.23 | B 959 | 4.55 | B 1000 | 4.88 |
| 7,500 | B 878 | 4.24 | B 925 | 4.61 | B 966 | 4.94 | 1005 | 5.26 | 1043 | 5.60 |
| 8,000 | 929 | 4.98 | 975 | 5.37 | 1015 | 5.72 | 1052 | 6.06 | C 1088 | 6.40 |
| 8,500 | 981 | 5.78 | 1026 | 6.20 | C 1064 | 6.58 | C 1100 | 6.93 | 1134 | 7.28 |
| 9,000 | C 1033 | 6.67 | C 1076 | 7.12 | C 1114 | 7.51 | 1148 | 7.89 | 1181 | 8.25 |
| 9,500 | 1085 | 7.64 | 1128 | 8.12 | 1164 | 8.54 | 1198 | 8.93 | D 1229 | 9.31 |
| 10,000 | 1137 | 8.69 | D 1179 | 9.20 | D 1214 | 9.64 | D 1247 | 10.05 | 1278 | 10.45 |
| 10,500 | D 1190 | 9.82 | D 1230 | 10.37 | D 1265 | 10.84 | 1297 | 11.27 | 1327 | 11.68 |
| 11,000 | 1242 | 11.05 | 1282 | 11.63 | 1316 | 12.12 | 1347 | 12.58 | 1376 | 13.01 |
| 11,500 | 1294 | 12.37 | 1333 | 12.98 | 1367 | 13.50 | — | — | — | — |
| 12,000 | 1347 | 13.78 | — | — | — | — | — | — | — | — |
| 12,500 | — | — | — | — | — | — | — | — | — | — |

| AIRFLOW (Cfm) | AVAILABLE EXTERNAL STATIC PRESSURE (in. wg) | | | | | | | | | |
|------------------|---|--------------|-------------|--------------|-------------|--------------|-------------|--------------|-------------|--------------|
| | 1.2 | | 1.4 | | 1.6 | | 1.8 | | 2.0 | |
| | Rpm | Bhp | Rpm | Bhp | Rpm | Bhp | Rpm | Bhp | Rpm | Bhp |
| 6,500 | B 1004 | 4.62 | 1050 | 5.03 | 1098 | 5.48 | C 1145 | 5.97 | 1192 | 6.49 |
| 7,000 | 1041 | 5.24 | C 1083 | 5.64 | C 1126 | 6.07 | C 1170 | 6.54 | D 1214 | 7.04 |
| 7,500 | C 1081 | 5.96 | C 1120 | 6.34 | 1159 | 6.75 | 1199 | 7.20 | 1240 | 7.68 |
| 8,000 | 1124 | 6.76 | 1160 | 7.13 | 1196 | 7.54 | D 1233 | 7.97 | 1270 | 8.43 |
| 8,500 | 1168 | 7.64 | 1202 | 8.02 | D 1235 | 8.42 | 1269 | 8.84 | 1304 | 9.28 |
| 9,000 | D 1214 | 8.62 | D 1245 | 9.00 | 1277 | 9.39 | 1309 | 9.81 | 1341 | 10.24 |
| 9,500 | 1260 | 9.69 | 1290 | 10.07 | 1320 | 10.47 | 1351 | 10.88 | 1381 | 11.31 |
| 10,000 | 1308 | 10.84 | 1337 | 11.23 | 1365 | 11.63 | 1394 | 12.05 | — | — |
| 10,500 | 1356 | 12.09 | 1384 | 12.49 | — | — | — | — | — | — |
| 11,000 | — | — | — | — | — | — | — | — | — | — |
| 11,500 | — | — | — | — | — | — | — | — | — | — |
| 12,000 | — | — | — | — | — | — | — | — | — | — |
| 12,500 | — | — | — | — | — | — | — | — | — | — |

LEGEND

Bhp — Brake Horsepower Input to Fan

Boldface indicates field-supplied motor/drive required.

NOTES:

1. Motor drive ranges:

- (A) Low Range: 687-873, 5.75 Bhp
- (B) Mid-Low Range: 805-1007, 5.75 Bhp
- (C) Mid High Range: 941-1176, 8.63 Bhp
- (D) High Range: 1014-1297, 11.50 Bhp

All other rpms require field-supplied motor or drive.

2. See page 30 for general fan performance notes.

Table 11 — Fan Performance — 48PGF28 — Vertical Supply/Return Units

| AIRFLOW (Cfm) | AVAILABLE EXTERNAL STATIC PRESSURE (in. wg) | | | | | | | | | |
|------------------|---|--------------|-------------|--------------|-------------|--------------|-------------|--------------|-------------|--------------|
| | 0.2 | | 0.4 | | 0.6 | | 0.8 | | 1.0 | |
| | Rpm | Bhp | Rpm | Bhp | Rpm | Bhp | Rpm | Bhp | Rpm | Bhp |
| 6,500 | A 775 | 2.99 | A 825 | 3.30 | A 871 | 3.60 | 915 | 3.91 | B 959 | 4.25 |
| 7,000 | 826 | 3.58 | 875 | 3.92 | 918 | 4.23 | B 959 | 4.55 | B 1000 | 4.88 |
| 7,500 | B 878 | 4.24 | B 925 | 4.61 | B 966 | 4.94 | 1005 | 5.26 | 1043 | 5.60 |
| 8,000 | 929 | 4.98 | 975 | 5.37 | 1015 | 5.72 | 1052 | 6.06 | C 1088 | 6.40 |
| 8,500 | 981 | 5.78 | 1026 | 6.20 | C 1064 | 6.58 | C 1100 | 6.93 | 1134 | 7.28 |
| 9,000 | C 1033 | 6.67 | C 1076 | 7.12 | C 1114 | 7.51 | 1148 | 7.89 | 1181 | 8.25 |
| 9,500 | 1085 | 7.64 | 1128 | 8.12 | 1164 | 8.54 | 1198 | 8.93 | D 1229 | 9.31 |
| 10,000 | 1137 | 8.69 | D 1179 | 9.20 | D 1214 | 9.64 | D 1247 | 10.05 | 1278 | 10.45 |
| 10,500 | D 1190 | 9.82 | D 1230 | 10.37 | D 1265 | 10.84 | 1297 | 11.27 | 1327 | 11.68 |
| 11,000 | 1242 | 11.05 | 1282 | 11.63 | 1316 | 12.12 | 1347 | 12.58 | 1376 | 13.01 |
| 11,500 | 1294 | 12.37 | 1333 | 12.98 | 1367 | 13.50 | — | — | — | — |
| 12,000 | 1347 | 13.78 | — | — | — | — | — | — | — | — |
| 12,500 | — | — | — | — | — | — | — | — | — | — |

| AIRFLOW (Cfm) | AVAILABLE EXTERNAL STATIC PRESSURE (in. wg) | | | | | | | | | |
|------------------|---|--------------|-------------|--------------|-------------|--------------|-------------|--------------|-------------|--------------|
| | 1.2 | | 1.4 | | 1.6 | | 1.8 | | 2.0 | |
| | Rpm | Bhp | Rpm | Bhp | Rpm | Bhp | Rpm | Bhp | Rpm | Bhp |
| 6,500 | B 1004 | 4.62 | 1050 | 5.03 | 1098 | 5.48 | 1145 | 5.97 | 1192 | 6.49 |
| 7,000 | 1041 | 5.24 | 1083 | 5.64 | C 1126 | 6.07 | C 1170 | 6.54 | D 1214 | 7.04 |
| 7,500 | C 1081 | 5.96 | C 1120 | 6.34 | 1159 | 6.75 | 1199 | 7.20 | D 1240 | 7.68 |
| 8,000 | 1124 | 6.76 | 1160 | 7.13 | 1196 | 7.54 | D 1233 | 7.97 | 1270 | 8.43 |
| 8,500 | 1168 | 7.64 | 1202 | 8.02 | D 1235 | 8.42 | 1269 | 8.84 | 1304 | 9.28 |
| 9,000 | 1214 | 8.62 | D 1245 | 9.00 | 1277 | 9.39 | 1309 | 9.81 | 1341 | 10.24 |
| 9,500 | D 1260 | 9.69 | 1290 | 10.07 | 1320 | 10.47 | 1351 | 10.88 | 1381 | 11.31 |
| 10,000 | 1308 | 10.84 | 1337 | 11.23 | 1365 | 11.63 | 1394 | 12.05 | — | — |
| 10,500 | 1356 | 12.09 | 1384 | 12.49 | — | — | — | — | — | — |
| 11,000 | — | — | — | — | — | — | — | — | — | — |
| 11,500 | — | — | — | — | — | — | — | — | — | — |
| 12,000 | — | — | — | — | — | — | — | — | — | — |
| 12,500 | — | — | — | — | — | — | — | — | — | — |

LEGEND

Bhp — Brake Horsepower Input to Fan

Boldface indicates field-supplied motor/drive required.

NOTES:

1. Motor drive ranges:

- (A) Low Range: 687-873, 5.75 Bhp
- (B) Mid-Low Range: 805-1007, 5.75 Bhp
- (C) Mid High Range: 941-1176, 8.63 Bhp
- (D) High Range: 1014-1297, 11.50 Bhp

All other rpms require field-supplied motor or drive.

2. See page 30 for general fan performance notes.

Table 12 — Fan Performance — 50PG20 — Vertical Supply/Return Units

| AIRFLOW (Cfm) | AVAILABLE EXTERNAL STATIC PRESSURE (in. wg) | | | | | | | | | |
|------------------|---|------|-------|------|-------|------|-------|------|--------|------|
| | 0.2 | | 0.4 | | 0.6 | | 0.8 | | 1.0 | |
| | Rpm | Bhp | Rpm | Bhp | Rpm | Bhp | Rpm | Bhp | Rpm | Bhp |
| 5000 | 533 | 1.27 | 611 | 1.54 | 682 | 1.82 | 748 | 2.10 | 808 | 2.37 |
| 5500 | 571 | 1.57 | 643 | 1.86 | 711 | 2.15 | 773 | 2.44 | 832 | 2.73 |
| 6000 | 610 | 1.92 | 676 | 2.21 | 740 | 2.52 | 800 | 2.82 | A 857 | 3.13 |
| 6500 | 650 | 2.31 | 712 | 2.61 | A 772 | 2.93 | A 829 | 3.25 | 883 | 3.58 |
| 7000 | 691 | 2.75 | A 748 | 3.06 | 805 | 3.39 | 859 | 3.73 | 911 | 4.07 |
| 7500 | A 732 | 3.24 | A 786 | 3.57 | 839 | 3.91 | 891 | 4.25 | 941 | 4.61 |
| 8000 | 775 | 3.79 | 824 | 4.12 | 874 | 4.47 | 924 | 4.83 | B 972 | 5.19 |
| 8500 | 817 | 4.40 | 863 | 4.74 | 911 | 5.09 | B 958 | 5.46 | C 1003 | 5.84 |
| 9000 | 860 | 5.06 | 904 | 5.41 | C 948 | 5.77 | C 993 | 6.15 | 1036 | 6.54 |

| AIRFLOW (Cfm) | AVAILABLE EXTERNAL STATIC PRESSURE (in. wg) | | | | | | | | | |
|------------------|---|------|--------|------|--------|------|--------|------|--------|------|
| | 1.2 | | 1.4 | | 1.6 | | 1.8 | | 2.0 | |
| | Rpm | Bhp | Rpm | Bhp | Rpm | Bhp | Rpm | Bhp | Rpm | Bhp |
| 5000 | 865 | 2.64 | A 918 | 2.91 | 969 | 3.17 | 1018 | 3.44 | 1065 | 3.70 |
| 5500 | A 886 | 3.02 | 938 | 3.31 | 988 | 3.59 | 1035 | 3.87 | 1081 | 4.16 |
| 6000 | 910 | 3.44 | 960 | 3.74 | B 1008 | 4.05 | B 1054 | 4.35 | B 1099 | 4.65 |
| 6500 | 935 | 3.90 | B 984 | 4.22 | 1030 | 4.54 | 1075 | 4.86 | 1118 | 5.18 |
| 7000 | 961 | 4.40 | 1008 | 4.74 | 1054 | 5.08 | 1098 | 5.41 | 1140 | 5.75 |
| 7500 | B 989 | 4.96 | 1035 | 5.31 | 1079 | 5.66 | 1122 | 6.01 | C 1163 | 6.36 |
| 8000 | 1018 | 5.56 | 1062 | 5.93 | C 1105 | 6.29 | C 1147 | 6.66 | 1187 | 7.02 |
| 8500 | C 1048 | 6.22 | C 1091 | 6.60 | C 1133 | 6.98 | C 1173 | 7.36 | D 1212 | 7.73 |
| 9000 | 1079 | 6.93 | 1121 | 7.32 | 1161 | 7.71 | D 1201 | 8.11 | 1239 | 8.50 |

LEGEND

Bhp — Brake Horsepower Input to Fan

Boldface indicates field-supplied drive required.

NOTES:

- Motor drive ranges:
(A) Low Range: 685-939, 4.26 Bhp (208/230 and 460-v), 751-954, 5.75 Bhp 4 (575-v)
(B) Mid-Low Range: 949-1206, 5.75 Bhp
(C) Mid-High Range: 941-1176, 8.63 Bhp
(D) High Range: 1014-1297, 11.50 Bhp
 All other rpms require field-supplied drive.
- See page 30 for general fan performance notes.

Table 13 — Fan Performance — 50PG24 — Vertical Supply/Return Units

| AIRFLOW (Cfm) | AVAILABLE EXTERNAL STATIC PRESSURE (in. wg) | | | | | | | | | |
|------------------|---|-------------|--------------|-------------|--------------|-------------|---------------|-------------|---------------|-------------|
| | 0.2 | | 0.4 | | 0.6 | | 0.8 | | 1.0 | |
| | Rpm | Bhp | Rpm | Bhp | Rpm | Bhp | Rpm | Bhp | Rpm | Bhp |
| 5,500 | 571 | 1.57 | 643 | 1.86 | 711 | 2.15 | 773 | 2.44 | 832 | 2.73 |
| 6,000 | 610 | 1.92 | 676 | 2.21 | 740 | 2.52 | 800 | 2.82 | A 857 | 3.13 |
| 6,500 | 650 | 2.31 | 712 | 2.61 | A 772 | 2.93 | A 829 | 3.25 | A 883 | 3.58 |
| 7,000 | 691 | 2.75 | A 748 | 3.06 | 805 | 3.39 | 859 | 3.73 | 911 | 4.07 |
| 7,500 | A 732 | 3.24 | 786 | 3.57 | 839 | 3.91 | 891 | 4.25 | 941 | 4.61 |
| 8,000 | 775 | 3.79 | 824 | 4.12 | 874 | 4.47 | 924 | 4.83 | B 972 | 5.19 |
| 8,500 | 817 | 4.40 | 863 | 4.74 | 911 | 5.09 | B 958 | 5.46 | 1003 | 5.84 |
| 9,000 | 860 | 5.06 | 904 | 5.41 | 948 | 5.77 | 993 | 6.15 | C 1036 | 6.54 |
| 9,500 | 903 | 5.79 | 944 | 6.14 | C 986 | 6.51 | C 1028 | 6.90 | C 1070 | 7.29 |
| 10,000 | C 947 | 6.57 | C 985 | 6.93 | 1025 | 7.32 | 1065 | 7.71 | 1105 | 8.11 |

| AIRFLOW (Cfm) | AVAILABLE EXTERNAL STATIC PRESSURE (in. wg) | | | | | | | | | |
|------------------|---|------|---------------|------|---------------|------|---------------|------|---------------|-------|
| | 1.2 | | 1.4 | | 1.6 | | 1.8 | | 2.0 | |
| | Rpm | Bhp | Rpm | Bhp | Rpm | Bhp | Rpm | Bhp | Rpm | Bhp |
| 5,500 | 886 | 3.02 | A 938 | 3.31 | 988 | 3.59 | 1035 | 3.87 | 1081 | 4.16 |
| 6,000 | A 910 | 3.44 | 960 | 3.74 | 1008 | 4.05 | 1054 | 4.35 | 1099 | 4.65 |
| 6,500 | 935 | 3.90 | B 984 | 4.22 | B 1030 | 4.54 | B 1075 | 4.86 | B 1118 | 5.18 |
| 7,000 | 961 | 4.40 | B 1008 | 4.74 | 1054 | 5.08 | 1098 | 5.41 | 1140 | 5.75 |
| 7,500 | B 989 | 4.96 | 1035 | 5.31 | 1079 | 5.66 | 1122 | 6.01 | C 1163 | 6.36 |
| 8,000 | 1018 | 5.56 | 1062 | 5.93 | 1105 | 6.29 | C 1147 | 6.66 | 1187 | 7.02 |
| 8,500 | 1048 | 6.22 | C 1091 | 6.60 | 1133 | 6.98 | 1173 | 7.36 | 1212 | 7.73 |
| 9,000 | 1079 | 6.93 | 1121 | 7.32 | 1161 | 7.71 | 1201 | 8.11 | D 1239 | 8.50 |
| 9,500 | C 1112 | 7.70 | 1152 | 8.10 | 1191 | 8.51 | D 1229 | 8.91 | 1266 | 9.32 |
| 10,000 | 1145 | 8.52 | D 1184 | 8.94 | 1222 | 9.36 | 1259 | 9.78 | 1295 | 10.20 |

LEGEND

Bhp — Brake Horsepower Input to Fan

Boldface indicates field-supplied drive required.

NOTES:

- Motor drive ranges:
(A) Low Range: 685-939, 4.26 Bhp (208/230 and 460-v), 751-954, 5.75 Bhp (5.75-v)
(B) Mid-Low Range: 949-1206, 5.75 Bhp
(C) Mid-High Range: 941-1176, 8.63 Bhp
(D) High Range: 1014-1297, 11.50 Bhp
 All other rpms require field-supplied drive.
- See page 30 for general fan performance notes.

Table 14 — Fan Performance — 50PG28 — Vertical Supply/Return Units

| AIRFLOW (Cfm) | AVAILABLE EXTERNAL STATIC PRESSURE (in. wg) | | | | | | | | | |
|------------------|---|-------|---------------|-------|---------------|--------------|---------------|--------------|---------------|--------------|
| | 0.2 | | 0.4 | | 0.6 | | 0.8 | | 1.0 | |
| | Rpm | Bhp | Rpm | Bhp | Rpm | Bhp | Rpm | Bhp | Rpm | Bhp |
| 6,500 | 734 | 2.74 | 752 | 2.85 | A 803 | 3.16 | A 848 | 3.45 | 891 | 3.74 |
| 7,000 | 728 | 2.88 | A 792 | 3.35 | 844 | 3.70 | 887 | 4.01 | B 928 | 4.30 |
| 7,500 | A 746 | 3.15 | 831 | 3.88 | 884 | 4.29 | B 927 | 4.63 | 966 | 4.94 |
| 8,000 | 786 | 3.62 | 869 | 4.45 | B 925 | 4.94 | B 968 | 5.30 | 1006 | 5.64 |
| 8,500 | 827 | 4.15 | B 905 | 5.04 | 964 | 5.63 | 1008 | 6.04 | 1046 | 6.40 |
| 9,000 | 870 | 4.74 | B 940 | 5.66 | 1003 | 6.36 | C 1049 | 6.83 | C 1086 | 7.22 |
| 9,500 | B 913 | 5.40 | 975 | 6.30 | C 1042 | 7.13 | 1089 | 7.68 | 1127 | 8.11 |
| 10,000 | 957 | 6.11 | C 1010 | 6.98 | 1079 | 7.94 | 1128 | 8.57 | 1167 | 9.06 |
| 10,500 | C 1002 | 6.89 | 1047 | 7.72 | 1115 | 8.78 | D 1167 | 9.52 | D 1207 | 10.06 |
| 11,000 | 1047 | 7.73 | 1086 | 8.53 | D 1150 | 9.65 | 1205 | 10.50 | 1247 | 11.13 |
| 11,500 | 1092 | 8.63 | 1126 | 9.41 | 1185 | 10.54 | 1242 | 11.53 | 1286 | 12.24 |
| 12,000 | D 1137 | 9.61 | D 1168 | 10.36 | 1220 | 11.47 | 1278 | 12.59 | 1325 | 13.40 |
| 12,500 | 1182 | 10.65 | 1210 | 11.39 | 1256 | 12.46 | 1314 | 13.68 | — | — |

| AIRFLOW (Cfm) | AVAILABLE EXTERNAL STATIC PRESSURE (in. wg) | | | | | | | | | |
|------------------|---|--------------|---------------|--------------|---------------|--------------|---------------|--------------|---------------|--------------|
| | 1.2 | | 1.4 | | 1.6 | | 1.8 | | 2.0 | |
| | Rpm | Bhp | Rpm | Bhp | Rpm | Bhp | Rpm | Bhp | Rpm | Bhp |
| 6,500 | 934 | 4.05 | B 978 | 4.40 | 1023 | 4.78 | 1071 | 5.22 | 1119 | 5.71 |
| 7,000 | B 967 | 4.61 | 1007 | 4.94 | 1048 | 5.30 | C 1090 | 5.70 | C 1134 | 6.15 |
| 7,500 | 1003 | 5.25 | 1040 | 5.57 | C 1078 | 5.92 | 1116 | 6.30 | 1155 | 6.71 |
| 8,000 | 1041 | 5.96 | C 1076 | 6.29 | 1111 | 6.63 | 1146 | 6.99 | 1181 | 7.37 |
| 8,500 | C 1081 | 6.74 | 1114 | 7.07 | 1147 | 7.42 | 1179 | 7.77 | D 1212 | 8.14 |
| 9,000 | 1121 | 7.59 | 1153 | 7.93 | 1184 | 8.28 | D 1215 | 8.64 | 1246 | 9.01 |
| 9,500 | 1161 | 8.50 | 1193 | 8.87 | D 1223 | 9.23 | 1253 | 9.59 | 1282 | 9.96 |
| 10,000 | D 1202 | 9.48 | D 1233 | 9.87 | 1263 | 10.25 | 1291 | 10.62 | 1319 | 11.00 |
| 10,500 | 1242 | 10.53 | 1273 | 10.95 | 1303 | 11.35 | 1331 | 11.73 | 1358 | 12.12 |
| 11,000 | 1282 | 11.64 | 1314 | 12.09 | 1343 | 12.52 | 1371 | 12.92 | 1397 | 13.32 |
| 11,500 | 1322 | 12.81 | 1354 | 13.30 | 1384 | 13.76 | — | — | — | — |
| 12,000 | — | — | — | — | — | — | — | — | — | — |
| 12,500 | — | — | — | — | — | — | — | — | — | — |

LEGEND

Bhp — Brake Horsepower Input to Fan

Boldface indicates field-supplied motor and drive required.

NOTES:

1. Motor drive ranges:

- (A) Low Range: 687-873, 5.75 Bhp
- (B) Mid-Low Range: 805-1007, 5.75 Bhp
- (C) Mid-High Range: 941-1176, 8.63 Bhp
- (D) High Range: 1014-1297, 11.50 Bhp

All other rpms require field-supplied motor/drive.

2. See page 30 for general fan performance notes.

Table 15 — Fan Performance — 48PGD20 — Horizontal Supply and Return Units

| AIRFLOW (Cfm) | AVAILABLE EXTERNAL STATIC PRESSURE (in. wg) | | | | | | | | | |
|------------------|---|-------------|---------------|-------------|---------------|-------------|---------------|-------------|---------------|-------------|
| | 0.2 | | 0.4 | | 0.6 | | 0.8 | | 1.0 | |
| | Rpm | Bhp | Rpm | Bhp | Rpm | Bhp | Rpm | Bhp | Rpm | Bhp |
| 5000 | 862 | 2.65 | 917 | 2.93 | F 969 | 3.21 | F 1019 | 3.17 | F 1066 | 3.52 |
| 5500 | F 937 | 3.26 | F 988 | 3.56 | F 1036 | 3.53 | F 1083 | 3.90 | G 1127 | 4.28 |
| 6000 | F 1013 | 3.58 | 1060 | 3.96 | 1105 | 4.35 | 1149 | 4.75 | G 1191 | 5.16 |
| 6500 | 1089 | 4.48 | G 1133 | 4.89 | G 1175 | 5.31 | G 1216 | 5.73 | H 1256 | 6.17 |
| 7000 | G 1166 | 5.52 | H 1207 | 5.96 | H 1247 | 6.41 | H 1285 | 6.86 | H 1323 | 7.32 |
| 7500 | H 1243 | 6.71 | H 1282 | 7.18 | H 1319 | 7.66 | 1355 | 8.14 | 1391 | 8.63 |
| 8000 | 1320 | 8.07 | 1356 | 8.57 | 1392 | 9.08 | — | — | — | — |
| 8500 | 1398 | 9.60 | — | — | — | — | — | — | — | — |
| 9000 | — | — | — | — | — | — | — | — | — | — |

| AIRFLOW (Cfm) | AVAILABLE EXTERNAL STATIC PRESSURE (in. wg) | | | | | | | | | |
|------------------|---|-------------|---------------|-------------|---------------|-------------|---------------|-------------|---------------|-------------|
| | 1.2 | | 1.4 | | 1.6 | | 1.8 | | 2.0 | |
| | Rpm | Bhp | Rpm | Bhp | Rpm | Bhp | Rpm | Bhp | Rpm | Bhp |
| 5000 | F 1112 | 3.88 | F 1156 | 4.25 | G 1199 | 4.63 | G 1240 | 5.02 | G 1280 | 5.42 |
| 5500 | G 1171 | 4.67 | G 1212 | 5.06 | G 1253 | 5.47 | H 1292 | 5.88 | H 1331 | 6.30 |
| 6000 | G 1232 | 5.57 | H 1271 | 6.00 | H 1310 | 6.43 | 1348 | 6.87 | 1384 | 7.31 |
| 6500 | H 1295 | 6.61 | H 1333 | 7.06 | 1369 | 7.52 | — | — | — | — |
| 7000 | 1360 | 7.80 | 1396 | 8.27 | — | — | — | — | — | — |
| 7500 | — | — | — | — | — | — | — | — | — | — |
| 8000 | — | — | — | — | — | — | — | — | — | — |
| 8500 | — | — | — | — | — | — | — | — | — | — |
| 9000 | — | — | — | — | — | — | — | — | — | — |

LEGEND

Bhp — Brake Horsepower Input to Fan

Boldface indicates field-supplied motor/drive required.

NOTES:

- Motor drive ranges:
(E) Low Range: Not Used
(F) Mid-Low Range: 896-1227, 4.26 Bhp (208/230 and 460-v), 873-1108, 5.75 Bhp (575-v)
(G) Mid-High Range: 1113-1414, 5.75 Bhp
(H) High Range: 1096-1339, 8.63 Bhp
 All other rpms require field-supplied motor or drive.
- See page 30 for general fan performance notes.

Table 16 — Fan Performance — 48PGE20 — Horizontal Supply and Return Units

| AIRFLOW (Cfm) | AVAILABLE EXTERNAL STATIC PRESSURE (in. wg) | | | | | | | | | |
|------------------|---|-------------|---------------|-------------|---------------|-------------|---------------|-------------|---------------|-------------|
| | 0.2 | | 0.4 | | 0.6 | | 0.8 | | 1.0 | |
| | Rpm | Bhp | Rpm | Bhp | Rpm | Bhp | Rpm | Bhp | Rpm | Bhp |
| 5000 | 875 | 2.74 | 931 | 3.04 | F 984 | 3.34 | F 1035 | 3.33 | F 1083 | 3.69 |
| 5500 | F 952 | 3.38 | F 1003 | 3.32 | 1053 | 3.70 | 1100 | 4.09 | G 1145 | 4.49 |
| 6000 | 1029 | 3.74 | 1077 | 4.15 | G 1123 | 4.56 | G 1167 | 4.98 | G 1210 | 5.41 |
| 6500 | 1106 | 4.67 | G 1151 | 5.11 | G 1194 | 5.56 | H 1236 | 6.01 | H 1276 | 6.47 |
| 7000 | G 1184 | 5.75 | H 1226 | 6.23 | H 1266 | 6.71 | H 1306 | 7.19 | 1344 | 7.68 |
| 7500 | H 1262 | 7.00 | 1302 | 7.50 | 1340 | 8.01 | 1377 | 8.53 | — | — |
| 8000 | 1341 | 8.41 | 1378 | 8.95 | — | — | — | — | — | — |
| 8500 | — | — | — | — | — | — | — | — | — | — |
| 9000 | — | — | — | — | — | — | — | — | — | — |

| AIRFLOW (Cfm) | AVAILABLE EXTERNAL STATIC PRESSURE (in. wg) | | | | | | | | | |
|------------------|---|-------------|---------------|-------------|---------------|-------------|---------------|-------------|---------------|-------------|
| | 1.2 | | 1.4 | | 1.6 | | 1.8 | | 2.0 | |
| | Rpm | Bhp | Rpm | Bhp | Rpm | Bhp | Rpm | Bhp | Rpm | Bhp |
| 5000 | F 1130 | 4.07 | G 1174 | 4.45 | G 1218 | 4.84 | G 1259 | 5.23 | G 1300 | 5.63 |
| 5500 | G 1189 | 4.90 | 1232 | 5.31 | 1273 | 5.72 | H 1313 | 6.15 | 1352 | 6.58 |
| 6000 | H 1251 | 5.85 | H 1292 | 6.29 | H 1331 | 6.74 | 1369 | 7.19 | — | — |
| 6500 | 1315 | 6.94 | 1354 | 7.41 | 1391 | 7.89 | — | — | — | — |
| 7000 | 1381 | 8.18 | — | — | — | — | — | — | — | — |
| 7500 | — | — | — | — | — | — | — | — | — | — |
| 8000 | — | — | — | — | — | — | — | — | — | — |
| 8500 | — | — | — | — | — | — | — | — | — | — |
| 9000 | — | — | — | — | — | — | — | — | — | — |

LEGEND

Bhp — Brake Horsepower Input to Fan

Boldface indicates field-supplied motor/drive required.

NOTES:

- Motor drive ranges:
(E) Low Range: Not Used
(F) Mid-Low Range: 896-1227, 4.26 Bhp (208/230 and 460-v), 873-1108, 5.75 Bhp (575-v)
(G) Mid-High Range: 1113-1414, 5.75 Bhp
(H) High Range: 1096-1339, 8.63 Bhp

All other rpms require field-supplied motor or drive.

- See page 30 for general fan performance notes.

Table 17 — Fan Performance — 48PGF20 — Horizontal Supply and Return Units

| AIRFLOW (Cfm) | AVAILABLE EXTERNAL STATIC PRESSURE (in. wg) | | | | | | | | | |
|------------------|---|-------------|---------------|-------------|---------------|-------------|---------------|-------------|---------------|-------------|
| | 0.2 | | 0.4 | | 0.6 | | 0.8 | | 1.0 | |
| | Rpm | Bhp | Rpm | Bhp | Rpm | Bhp | Rpm | Bhp | Rpm | Bhp |
| 5000 | 875 | 2.74 | 931 | 3.04 | F 984 | 3.34 | F 1035 | 3.33 | F 1083 | 3.69 |
| 5500 | F 952 | 3.38 | F 1003 | 3.32 | 1053 | 3.70 | 1100 | 4.09 | G 1145 | 4.49 |
| 6000 | 1029 | 3.74 | 1077 | 4.15 | G 1123 | 4.56 | G 1167 | 4.98 | 1210 | 5.41 |
| 6500 | 1106 | 4.67 | G 1151 | 5.11 | 1194 | 5.56 | 1236 | 6.01 | H 1276 | 6.47 |
| 7000 | G 1184 | 5.75 | H 1226 | 6.23 | H 1266 | 6.71 | H 1306 | 7.19 | 1344 | 7.68 |
| 7500 | H 1262 | 7.00 | 1302 | 7.50 | 1340 | 8.01 | 1377 | 8.53 | — | — |
| 8000 | 1341 | 8.41 | 1378 | 8.95 | — | — | — | — | — | — |
| 8500 | — | — | — | — | — | — | — | — | — | — |
| 9000 | — | — | — | — | — | — | — | — | — | — |

| AIRFLOW (Cfm) | AVAILABLE EXTERNAL STATIC PRESSURE (in. wg) | | | | | | | | | |
|------------------|---|-------------|---------------|-------------|---------------|-------------|---------------|-------------|---------------|-------------|
| | 1.2 | | 1.4 | | 1.6 | | 1.8 | | 2.0 | |
| | Rpm | Bhp | Rpm | Bhp | Rpm | Bhp | Rpm | Bhp | Rpm | Bhp |
| 5000 | F 1130 | 4.07 | G 1174 | 4.45 | G 1218 | 4.84 | G 1259 | 5.23 | G 1300 | 5.63 |
| 5500 | G 1189 | 4.90 | 1232 | 5.31 | 1273 | 5.72 | H 1313 | 6.15 | 1352 | 6.58 |
| 6000 | H 1251 | 5.85 | H 1292 | 6.29 | H 1331 | 6.74 | 1369 | 7.19 | — | — |
| 6500 | 1315 | 6.94 | 1354 | 7.41 | 1391 | 7.89 | — | — | — | — |
| 7000 | 1381 | 8.18 | — | — | — | — | — | — | — | — |
| 7500 | — | — | — | — | — | — | — | — | — | — |
| 8000 | — | — | — | — | — | — | — | — | — | — |
| 8500 | — | — | — | — | — | — | — | — | — | — |
| 9000 | — | — | — | — | — | — | — | — | — | — |

LEGEND

Bhp — Brake Horsepower Input to Fan

Boldface indicates field-supplied motor/drive required.

NOTES:

- Motor drive ranges:
(E) Low Range: Not Used
(F) Mid-Low Range: 896-1227, 4.26 Bhp (208/230 and 460-v), 873-1108, 5.75 Bhp (575-v)
(G) Mid-High Range: 1113-1414, 5.75 Bhp
(H) High Range: 1096-1339, 8.63 Bhp

All other rpms require field-supplied motor or drive.

- See page 30 for general fan performance notes.

Table 18 — Fan Performance — 48PGD24 — Horizontal Supply and Return Units

| AIRFLOW (Cfm) | AVAILABLE EXTERNAL STATIC PRESSURE (in. wg) | | | | | | | | | |
|------------------|---|-------------|-------------|-------------|-------------|-------------|-------------|-------------|-------------|-------------|
| | 0.2 | | 0.4 | | 0.6 | | 0.8 | | 1.0 | |
| | Rpm | Bhp | Rpm | Bhp | Rpm | Bhp | Rpm | Bhp | Rpm | Bhp |
| 5,500 | F 937 | 3.26 | F 988 | 3.56 | F 1036 | 3.53 | F 1083 | 3.90 | G 1127 | 4.28 |
| 6,000 | 1013 | 3.58 | F 1060 | 3.96 | 1105 | 4.35 | G 1149 | 4.75 | 1191 | 5.16 |
| 6,500 | 1089 | 4.48 | G 1133 | 4.89 | G 1175 | 5.31 | G 1216 | 5.73 | H 1256 | 6.17 |
| 7,000 | G 1166 | 5.52 | H 1207 | 5.96 | H 1247 | 6.41 | H 1285 | 6.86 | H 1323 | 7.32 |
| 7,500 | H 1243 | 6.71 | H 1282 | 7.18 | H 1319 | 7.66 | 1355 | 8.14 | 1391 | 8.63 |
| 8,000 | 1320 | 8.07 | 1356 | 8.57 | 1392 | 9.08 | — | — | — | — |
| 8,500 | 1398 | 9.60 | — | — | — | — | — | — | — | — |
| 9,000 | — | — | — | — | — | — | — | — | — | — |
| 9,500 | — | — | — | — | — | — | — | — | — | — |
| 10,000 | — | — | — | — | — | — | — | — | — | — |

| AIRFLOW (Cfm) | AVAILABLE EXTERNAL STATIC PRESSURE (in. wg) | | | | | | | | | |
|------------------|---|-------------|-------------|-------------|-------------|-------------|-------------|-------------|-------------|-------------|
| | 1.2 | | 1.4 | | 1.6 | | 1.8 | | 2.0 | |
| | Rpm | Bhp | Rpm | Bhp | Rpm | Bhp | Rpm | Bhp | Rpm | Bhp |
| 5,500 | G 1171 | 4.67 | G 1212 | 5.06 | G 1253 | 5.47 | H 1292 | 5.88 | H 1331 | 6.30 |
| 6,000 | 1232 | 5.57 | H 1271 | 6.00 | H 1310 | 6.43 | 1348 | 6.87 | 1384 | 7.31 |
| 6,500 | H 1295 | 6.61 | H 1333 | 7.06 | 1369 | 7.52 | — | — | — | — |
| 7,000 | 1360 | 7.80 | 1396 | 8.27 | — | — | — | — | — | — |
| 7,500 | — | — | — | — | — | — | — | — | — | — |
| 8,000 | — | — | — | — | — | — | — | — | — | — |
| 8,500 | — | — | — | — | — | — | — | — | — | — |
| 9,000 | — | — | — | — | — | — | — | — | — | — |
| 9,500 | — | — | — | — | — | — | — | — | — | — |
| 10,000 | — | — | — | — | — | — | — | — | — | — |

LEGEND

Bhp — Brake Horsepower Input to Fan

Boldface indicates field-supplied motor/drive required.

NOTES:

- Motor drive ranges:
 (E) Low Range: Not Used
 (F) Mid-Low Range: 896-1227, 4.26 Bhp (208/230 and 460-v), 873-1108, 5.75 Bhp (575-v)
 (G) Mid-High Range: 1113-1414, 5.75 Bhp
 (H) High Range: 1096-1339, 8.63 Bhp
 All other rpms require field-supplied motor or drive.
- See page 30 for general fan performance notes.

Table 19 — Fan Performance — 48PGE24 — Horizontal Supply and Return Units

| AIRFLOW (Cfm) | AVAILABLE EXTERNAL STATIC PRESSURE (in. wg) | | | | | | | | | |
|------------------|---|-------------|-------------|-------------|-------------|-------------|-------------|-------------|-------------|-------------|
| | 0.2 | | 0.4 | | 0.6 | | 0.8 | | 1.0 | |
| | Rpm | Bhp | Rpm | Bhp | Rpm | Bhp | Rpm | Bhp | Rpm | Bhp |
| 5,500 | F 952 | 3.38 | F 1003 | 3.32 | F 1053 | 3.70 | F 1100 | 4.09 | G 1145 | 4.49 |
| 6,000 | F 1029 | 3.74 | F 1077 | 4.15 | G 1123 | 4.56 | G 1167 | 4.98 | G 1210 | 5.41 |
| 6,500 | 1106 | 4.67 | G 1151 | 5.11 | 1194 | 5.56 | 1236 | 6.01 | H 1276 | 6.47 |
| 7,000 | G 1184 | 5.75 | H 1226 | 6.23 | H 1266 | 6.71 | H 1306 | 7.19 | 1344 | 7.68 |
| 7,500 | H 1262 | 7.00 | H 1302 | 7.50 | 1340 | 8.01 | 1377 | 8.53 | — | — |
| 8,000 | 1341 | 8.41 | 1378 | 8.95 | — | — | — | — | — | — |
| 8,500 | — | — | — | — | — | — | — | — | — | — |
| 9,000 | — | — | — | — | — | — | — | — | — | — |
| 9,500 | — | — | — | — | — | — | — | — | — | — |
| 10,000 | — | — | — | — | — | — | — | — | — | — |

| AIRFLOW (Cfm) | AVAILABLE EXTERNAL STATIC PRESSURE (in. wg) | | | | | | | | | |
|------------------|---|-------------|-------------|-------------|-------------|-------------|-------------|-------------|-------------|-------------|
| | 1.2 | | 1.4 | | 1.6 | | 1.8 | | 2.0 | |
| | Rpm | Bhp | Rpm | Bhp | Rpm | Bhp | Rpm | Bhp | Rpm | Bhp |
| 5,500 | G 1189 | 4.90 | G 1232 | 5.31 | G 1273 | 5.72 | H 1313 | 6.15 | 1352 | 6.58 |
| 6,000 | H 1251 | 5.85 | H 1292 | 6.29 | H 1331 | 6.74 | 1369 | 7.19 | — | — |
| 6,500 | H 1315 | 6.94 | 1354 | 7.41 | 1391 | 7.89 | — | — | — | — |
| 7,000 | 1381 | 8.18 | — | — | — | — | — | — | — | — |
| 7,500 | — | — | — | — | — | — | — | — | — | — |
| 8,000 | — | — | — | — | — | — | — | — | — | — |
| 8,500 | — | — | — | — | — | — | — | — | — | — |
| 9,000 | — | — | — | — | — | — | — | — | — | — |
| 9,500 | — | — | — | — | — | — | — | — | — | — |
| 10,000 | — | — | — | — | — | — | — | — | — | — |

LEGEND

Bhp — Brake Horsepower Input to Fan

Boldface indicates field-supplied motor/drive required.

NOTES:

- Motor drive ranges:
 (E) Low Range: Not Used
 (F) Mid-Low Range: 896-1227, 4.26 Bhp (208/230 and 460-v), 873-1108, 5.75 Bhp (575-v)
 (G) Mid-High Range: 1113-1414, 5.75 Bhp
 (H) High Range: 1096-1339, 8.63 Bhp
 All other rpms require field-supplied motor or drive.
- See page 30 for general fan performance notes.

Table 20 — Fan Performance — 48PGF24 — Horizontal Supply and Return Units

| AIRFLOW (Cfm) | AVAILABLE EXTERNAL STATIC PRESSURE (in. wg) | | | | | | | | | |
|------------------|---|-------------|---------------|-------------|---------------|-------------|---------------|-------------|---------------|-------------|
| | 0.2 | | 0.4 | | 0.6 | | 0.8 | | 1.0 | |
| | Rpm | Bhp | Rpm | Bhp | Rpm | Bhp | Rpm | Bhp | Rpm | Bhp |
| 5,500 | F 952 | 3.38 | F 1003 | 3.32 | F 1053 | 3.70 | F 1100 | 4.09 | G 1145 | 4.49 |
| 6,000 | 1029 | 3.74 | 1077 | 4.15 | G 1123 | 4.56 | G 1167 | 4.98 | 1210 | 5.41 |
| 6,500 | 1106 | 4.67 | G 1151 | 5.11 | 1194 | 5.56 | 1236 | 6.01 | H 1276 | 6.47 |
| 7,000 | G 1184 | 5.75 | H 1226 | 6.23 | H 1266 | 6.71 | H 1306 | 7.19 | 1344 | 7.68 |
| 7,500 | H 1262 | 7.00 | H 1302 | 7.50 | 1340 | 8.01 | 1377 | 8.53 | — | — |
| 8,000 | 1341 | 8.41 | 1378 | 8.95 | — | — | — | — | — | — |
| 8,500 | — | — | — | — | — | — | — | — | — | — |
| 9,000 | — | — | — | — | — | — | — | — | — | — |
| 9,500 | — | — | — | — | — | — | — | — | — | — |
| 10,000 | — | — | — | — | — | — | — | — | — | — |

| AIRFLOW (Cfm) | AVAILABLE EXTERNAL STATIC PRESSURE (in. wg) | | | | | | | | | |
|------------------|---|-------------|---------------|-------------|---------------|-------------|---------------|-------------|-------------|-------------|
| | 1.2 | | 1.4 | | 1.6 | | 1.8 | | 2.0 | |
| | Rpm | Bhp | Rpm | Bhp | Rpm | Bhp | Rpm | Bhp | Rpm | Bhp |
| 5,500 | G 1189 | 4.90 | G 1232 | 5.31 | G 1273 | 5.72 | H 1313 | 6.15 | 1352 | 6.58 |
| 6,000 | 1251 | 5.85 | H 1292 | 6.29 | H 1331 | 6.74 | 1369 | 7.19 | — | — |
| 6,500 | H 1315 | 6.94 | 1354 | 7.41 | 1391 | 7.89 | — | — | — | — |
| 7,000 | 1381 | 8.18 | — | — | — | — | — | — | — | — |
| 7,500 | — | — | — | — | — | — | — | — | — | — |
| 8,000 | — | — | — | — | — | — | — | — | — | — |
| 8,500 | — | — | — | — | — | — | — | — | — | — |
| 9,000 | — | — | — | — | — | — | — | — | — | — |
| 9,500 | — | — | — | — | — | — | — | — | — | — |
| 10,000 | — | — | — | — | — | — | — | — | — | — |

LEGEND

Bhp — Brake Horsepower Input to Fan

Boldface indicates field-supplied motor/drive required.

NOTES:

1. Motor drive ranges:

(E) Low Range: Not Used

(F) Mid-Low Range: 896-1227, 4.26 Bhp (208/230 and 460-v), 873-1108, 5.75 Bhp (575-v)

(G) Mid-High Range: 1113-1414, 5.75 Bhp

(H) High Range: 1096-1339, 8.63 Bhp

All other rpms require field-supplied motor or drive.

2. See page 30 for general fan performance notes.

Table 21 — Fan Performance — 48PGD28 — Horizontal Supply and Return Units

| AIRFLOW (Cfm) | AVAILABLE EXTERNAL STATIC PRESSURE (in. wg) | | | | | | | | | |
|------------------|---|--------------|---------------|--------------|---------------|--------------|---------------|--------------|---------------|--------------|
| | 0.2 | | 0.4 | | 0.6 | | 0.8 | | 1.0 | |
| | Rpm | Bhp | Rpm | Bhp | Rpm | Bhp | Rpm | Bhp | Rpm | Bhp |
| 6,500 | E 786 | 3.06 | E 819 | 3.26 | E 857 | 3.51 | 899 | 3.80 | F 943 | 4.12 |
| 7,000 | 842 | 3.69 | 871 | 3.89 | 905 | 4.14 | F 943 | 4.42 | F 983 | 4.74 |
| 7,500 | 898 | 4.40 | F 925 | 4.61 | F 955 | 4.85 | 989 | 5.13 | 1026 | 5.44 |
| 8,000 | F 955 | 5.20 | F 979 | 5.40 | 1007 | 5.65 | 1037 | 5.92 | 1070 | 6.23 |
| 8,500 | 1012 | 6.08 | 1034 | 6.29 | 1059 | 6.53 | G 1087 | 6.80 | G 1117 | 7.10 |
| 9,000 | G 1069 | 7.05 | G 1090 | 7.26 | G 1113 | 7.50 | 1138 | 7.77 | 1165 | 8.07 |
| 9,500 | 1127 | 8.11 | 1146 | 8.32 | 1167 | 8.57 | 1190 | 8.84 | 1215 | 9.13 |
| 10,000 | 1184 | 9.27 | H 1202 | 9.49 | H 1221 | 9.73 | H 1243 | 10.00 | H 1266 | 10.29 |
| 10,500 | 1242 | 10.52 | H 1258 | 10.75 | H 1276 | 10.99 | 1296 | 11.26 | 1318 | 11.55 |
| 11,000 | 1299 | 11.88 | 1315 | 12.11 | 1332 | 12.36 | 1350 | 12.63 | 1370 | 12.92 |
| 11,500 | 1357 | 13.35 | 1372 | 13.58 | — | — | — | — | — | — |
| 12,000 | — | — | — | — | — | — | — | — | — | — |
| 12,500 | — | — | — | — | — | — | — | — | — | — |

| AIRFLOW (Cfm) | AVAILABLE EXTERNAL STATIC PRESSURE (in. wg) | | | | | | | | | |
|------------------|---|--------------|---------------|--------------|---------------|--------------|---------------|--------------|---------------|--------------|
| | 1.2 | | 1.4 | | 1.6 | | 1.8 | | 2.0 | |
| | Rpm | Bhp | Rpm | Bhp | Rpm | Bhp | Rpm | Bhp | Rpm | Bhp |
| 6,500 | F 988 | 4.49 | 1035 | 4.89 | 1082 | 5.33 | G 1129 | 5.81 | 1177 | 6.32 |
| 7,000 | 1024 | 5.09 | G 1066 | 5.48 | G 1109 | 5.89 | G 1153 | 6.35 | 1197 | 6.84 |
| 7,500 | G 1063 | 5.79 | 1102 | 6.16 | G 1141 | 6.56 | 1181 | 6.99 | H 1221 | 7.46 |
| 8,000 | 1105 | 6.57 | 1140 | 6.93 | 1176 | 7.32 | H 1213 | 7.74 | 1250 | 8.18 |
| 8,500 | 1149 | 7.44 | 1181 | 7.79 | 1215 | 8.18 | H 1249 | 8.58 | 1283 | 9.02 |
| 9,000 | 1194 | 8.40 | H 1225 | 8.75 | H 1256 | 9.13 | 1287 | 9.53 | 1319 | 9.95 |
| 9,500 | H 1242 | 9.46 | 1270 | 9.80 | 1298 | 10.17 | 1328 | 10.57 | 1358 | 10.98 |
| 10,000 | 1290 | 10.61 | 1316 | 10.96 | 1343 | 11.32 | 1370 | 11.71 | 1399 | 12.12 |
| 10,500 | 1340 | 11.87 | 1364 | 12.21 | 1389 | 12.57 | — | — | — | — |
| 11,000 | 1391 | 13.23 | — | — | — | — | — | — | — | — |
| 11,500 | — | — | — | — | — | — | — | — | — | — |
| 12,000 | — | — | — | — | — | — | — | — | — | — |
| 12,500 | — | — | — | — | — | — | — | — | — | — |

LEGEND

Bhp — Brake Horsepower Input to Fan

Boldface indicates field-supplied motor/drive required.

NOTES:

1. Motor drive ranges:

- (E) Low Range: 687-873, 5.75 Bhp
- (F) Mid-Low Range: 805-1007, 5.75 Bhp
- (G) Mid-High Range: 941-1176, 8.63 Bhp
- (H) High Range: 1014-1297, 11.50 Bhp

All other rpms require field-supplied motor or drive.

2. See page 30 for general fan performance notes.

Table 22 — Fan Performance — 48PGE28 — Horizontal Supply and Return Units

| AIRFLOW (Cfm) | AVAILABLE EXTERNAL STATIC PRESSURE (in. wg) | | | | | | | | | |
|------------------|---|--------------|-------------|--------------|-------------|--------------|-------------|--------------|-------------|--------------|
| | 0.2 | | 0.4 | | 0.6 | | 0.8 | | 1.0 | |
| | Rpm | Bhp | Rpm | Bhp | Rpm | Bhp | Rpm | Bhp | Rpm | Bhp |
| 6,500 | E 799 | 3.14 | E 833 | 3.35 | E 872 | 3.61 | 914 | 3.90 | F 958 | 4.24 |
| 7,000 | 856 | 3.79 | 887 | 4.00 | F 921 | 4.25 | F 958 | 4.54 | 999 | 4.87 |
| 7,500 | F 913 | 4.52 | F 941 | 4.74 | F 972 | 4.99 | 1006 | 5.27 | 1042 | 5.59 |
| 8,000 | 971 | 5.33 | 996 | 5.55 | 1024 | 5.80 | 1055 | 6.08 | G 1088 | 6.40 |
| 8,500 | 1029 | 6.24 | 1052 | 6.46 | G 1078 | 6.71 | G 1106 | 6.99 | 1136 | 7.30 |
| 9,000 | G 1087 | 7.23 | G 1108 | 7.46 | 1132 | 7.71 | 1158 | 7.99 | 1185 | 8.29 |
| 9,500 | 1145 | 8.32 | 1165 | 8.55 | 1187 | 8.80 | H 1211 | 9.08 | H 1236 | 9.39 |
| 10,000 | H 1203 | 9.50 | H 1222 | 9.74 | H 1243 | 10.00 | H 1265 | 10.28 | 1288 | 10.58 |
| 10,500 | 1261 | 10.79 | H 1279 | 11.03 | 1299 | 11.29 | 1319 | 11.58 | 1341 | 11.88 |
| 11,000 | 1320 | 12.18 | 1337 | 12.43 | 1355 | 12.70 | 1374 | 12.98 | 1394 | 13.28 |
| 11,500 | 1378 | 13.68 | — | — | — | — | — | — | — | — |
| 12,000 | — | — | — | — | — | — | — | — | — | — |
| 12,500 | — | — | — | — | — | — | — | — | — | — |

| AIRFLOW (Cfm) | AVAILABLE EXTERNAL STATIC PRESSURE (in. wg) | | | | | | | | | |
|------------------|---|--------------|-------------|--------------|-------------|--------------|-------------|--------------|-------------|--------------|
| | 1.2 | | 1.4 | | 1.6 | | 1.8 | | 2.0 | |
| | Rpm | Bhp | Rpm | Bhp | Rpm | Bhp | Rpm | Bhp | Rpm | Bhp |
| 6,500 | F 1005 | 4.62 | 1052 | 5.05 | 1100 | 5.51 | G 1148 | 6.00 | 1195 | 6.52 |
| 7,000 | 1041 | 5.24 | G 1084 | 5.64 | G 1128 | 6.09 | 1172 | 6.57 | H 1217 | 7.08 |
| 7,500 | G 1080 | 5.94 | 1119 | 6.33 | 1160 | 6.76 | 1201 | 7.22 | 1242 | 7.71 |
| 8,000 | 1122 | 6.74 | 1158 | 7.12 | 1195 | 7.53 | H 1233 | 7.97 | 1272 | 8.45 |
| 8,500 | 1167 | 7.63 | 1200 | 8.00 | H 1234 | 8.40 | 1269 | 8.83 | 1304 | 9.29 |
| 9,000 | H 1214 | 8.63 | H 1244 | 8.99 | 1275 | 9.37 | 1308 | 9.79 | 1340 | 10.23 |
| 9,500 | 1262 | 9.72 | 1290 | 10.07 | 1319 | 10.45 | 1349 | 10.85 | 1379 | 11.28 |
| 10,000 | 1312 | 10.91 | 1338 | 11.25 | 1365 | 11.63 | 1392 | 12.02 | — | — |
| 10,500 | 1363 | 12.20 | 1387 | 12.55 | — | — | — | — | — | — |
| 11,000 | — | — | — | — | — | — | — | — | — | — |
| 11,500 | — | — | — | — | — | — | — | — | — | — |
| 12,000 | — | — | — | — | — | — | — | — | — | — |
| 12,500 | — | — | — | — | — | — | — | — | — | — |

LEGEND

Bhp — Brake Horsepower Input to Fan

Boldface indicates field-supplied motor/drive required.

NOTES:

1. Motor drive ranges:

- (E) Low Range: 687-873, 5.75 Bhp
- (F) Mid-Low Range: 805-1007, 5.75 Bhp
- (G) Mid-High Range: 941-1176, 8.63 Bhp
- (H) High Range: 1014-1297, 11.50 Bhp

All other rpms require field-supplied motor or drive.

2. See page 30 for general fan performance notes.

Table 23 — Fan Performance — 48PGF28 — Horizontal Supply and Return Units

| AIRFLOW (Cfm) | AVAILABLE EXTERNAL STATIC PRESSURE (in. wg) | | | | | | | | | |
|------------------|---|--------------|-------------|--------------|-------------|--------------|-------------|--------------|-------------|--------------|
| | 0.2 | | 0.4 | | 0.6 | | 0.8 | | 1.0 | |
| | Rpm | Bhp | Rpm | Bhp | Rpm | Bhp | Rpm | Bhp | Rpm | Bhp |
| 6,500 | E 799 | 3.14 | E 833 | 3.35 | E 872 | 3.61 | 914 | 3.90 | F 958 | 4.24 |
| 7,000 | 856 | 3.79 | 887 | 4.00 | F 921 | 4.25 | F 958 | 4.54 | 999 | 4.87 |
| 7,500 | F 913 | 4.52 | F 941 | 4.74 | F 972 | 4.99 | 1006 | 5.27 | 1042 | 5.59 |
| 8,000 | 971 | 5.33 | 996 | 5.55 | 1024 | 5.80 | 1055 | 6.08 | G 1088 | 6.40 |
| 8,500 | 1029 | 6.24 | 1052 | 6.46 | G 1078 | 6.71 | G 1106 | 6.99 | 1136 | 7.30 |
| 9,000 | G 1087 | 7.23 | G 1108 | 7.46 | 1132 | 7.71 | 1158 | 7.99 | 1185 | 8.29 |
| 9,500 | 1145 | 8.32 | 1165 | 8.55 | H 1187 | 8.80 | H 1211 | 9.08 | H 1236 | 9.39 |
| 10,000 | H 1203 | 9.50 | H 1222 | 9.74 | 1243 | 10.00 | 1265 | 10.28 | 1288 | 10.58 |
| 10,500 | 1261 | 10.79 | 1279 | 11.03 | 1299 | 11.29 | 1319 | 11.58 | 1341 | 11.88 |
| 11,000 | 1320 | 12.18 | 1337 | 12.43 | 1355 | 12.70 | 1374 | 12.98 | 1394 | 13.28 |
| 11,500 | 1378 | 13.68 | — | — | — | — | — | — | — | — |
| 12,000 | — | — | — | — | — | — | — | — | — | — |
| 12,500 | — | — | — | — | — | — | — | — | — | — |

| AIRFLOW (Cfm) | AVAILABLE EXTERNAL STATIC PRESSURE (in. wg) | | | | | | | | | |
|------------------|---|--------------|-------------|--------------|-------------|--------------|-------------|--------------|-------------|--------------|
| | 1.2 | | 1.4 | | 1.6 | | 1.8 | | 2.0 | |
| | Rpm | Bhp | Rpm | Bhp | Rpm | Bhp | Rpm | Bhp | Rpm | Bhp |
| 6,500 | F 1005 | 4.62 | 1052 | 5.05 | 1100 | 5.51 | G 1148 | 6.00 | 1195 | 6.52 |
| 7,000 | 1041 | 5.24 | G 1084 | 5.64 | G 1128 | 6.09 | 1172 | 6.57 | H 1217 | 7.08 |
| 7,500 | G 1080 | 5.94 | 1119 | 6.33 | 1160 | 6.76 | 1201 | 7.22 | 1242 | 7.71 |
| 8,000 | 1122 | 6.74 | 1158 | 7.12 | 1195 | 7.53 | H 1233 | 7.97 | 1272 | 8.45 |
| 8,500 | 1167 | 7.63 | 1200 | 8.00 | H 1234 | 8.40 | 1269 | 8.83 | 1304 | 9.29 |
| 9,000 | H 1214 | 8.63 | H 1244 | 8.99 | 1275 | 9.37 | 1308 | 9.79 | 1340 | 10.23 |
| 9,500 | 1262 | 9.72 | 1290 | 10.07 | 1319 | 10.45 | 1349 | 10.85 | 1379 | 11.28 |
| 10,000 | 1312 | 10.91 | 1338 | 11.25 | 1365 | 11.63 | 1392 | 12.02 | — | — |
| 10,500 | 1363 | 12.20 | 1387 | 12.55 | — | — | — | — | — | — |
| 11,000 | — | — | — | — | — | — | — | — | — | — |
| 11,500 | — | — | — | — | — | — | — | — | — | — |
| 12,000 | — | — | — | — | — | — | — | — | — | — |
| 12,500 | — | — | — | — | — | — | — | — | — | — |

LEGEND

Bhp — Brake Horsepower Input to Fan

Boldface indicates field-supplied motor/drive required.

NOTES:

1. Motor drive ranges:

(E) Low Range: 687-873, 5.75 Bhp

(F) Mid-Low Range: 805-1007, 5.75 Bhp

(G) Mid-High Range: 941-1176, 8.63 Bhp

(H) High Range: 1014-1297, 11.50 Bhp

All other rpms require field-supplied motor or drive.

2. See page 30 for general fan performance notes.

Table 24 — Fan Performance — 50PG20 — Horizontal Supply/Return Units

| AIRFLOW (Cfm) | AVAILABLE EXTERNAL STATIC PRESSURE (in. wg) | | | | | | | | | |
|------------------|---|-------------|------------|-------------|------------|-------------|------------|-------------|------------|-------------|
| | 0.2 | | 0.4 | | 0.6 | | 0.8 | | 1.0 | |
| | Rpm | Bhp | Rpm | Bhp | Rpm | Bhp | Rpm | Bhp | Rpm | Bhp |
| 5000 | 575 | 1.37 | 642 | 1.61 | 700 | 1.84 | 754 | 2.08 | 808 | 2.33 |
| 5500 | 619 | 1.71 | 682 | 1.96 | 737 | 2.21 | 788 | 2.45 | E 837 | 2.71 |
| 6000 | 663 | 2.09 | 723 | 2.35 | 776 | 2.62 | E 825 | 2.88 | E 871 | 3.14 |
| 6500 | 708 | 2.53 | 765 | 2.80 | E 816 | 3.08 | 863 | 3.35 | 906 | 3.63 |
| 7000 | E 753 | 3.02 | E 807 | 3.30 | 857 | 3.59 | 902 | 3.88 | 944 | 4.17 |
| 7500 | 800 | 3.58 | 850 | 3.86 | 898 | 4.16 | 942 | 4.47 | F 982 | 4.77 |
| 8000 | 847 | 4.20 | 894 | 4.48 | 940 | 4.80 | F 982 | 5.11 | F 1022 | 5.43 |
| 8500 | 894 | 4.88 | 939 | 5.17 | F 982 | 5.49 | G 1024 | 5.82 | G 1062 | 6.14 |
| 9000 | G 941 | 5.63 | G 983 | 5.92 | G 1025 | 6.24 | G 1065 | 6.58 | G 1103 | 6.92 |

| AIRFLOW (Cfm) | AVAILABLE EXTERNAL STATIC PRESSURE (in. wg) | | | | | | | | | |
|------------------|---|------|--------|------|--------|------|--------|------|--------|------|
| | 1.2 | | 1.4 | | 1.6 | | 1.8 | | 2.0 | |
| | Rpm | Bhp | Rpm | Bhp | Rpm | Bhp | Rpm | Bhp | Rpm | Bhp |
| 5000 | 862 | 2.60 | E 917 | 2.89 | 972 | 3.20 | 1028 | 3.53 | 1084 | 3.89 |
| 5500 | E 886 | 2.97 | 935 | 3.25 | 985 | 3.55 | 1035 | 3.87 | 1086 | 4.21 |
| 6000 | 916 | 3.41 | 960 | 3.69 | F 1005 | 3.98 | F 1050 | 4.29 | F 1096 | 4.61 |
| 6500 | 949 | 3.90 | F 990 | 4.19 | 1032 | 4.48 | 1073 | 4.78 | 1114 | 5.10 |
| 7000 | F 984 | 4.46 | 1023 | 4.75 | 1062 | 5.04 | 1100 | 5.34 | 1139 | 5.66 |
| 7500 | 1021 | 5.07 | 1059 | 5.37 | 1095 | 5.67 | G 1131 | 5.98 | G 1167 | 6.29 |
| 8000 | 1059 | 5.74 | 1095 | 6.05 | G 1130 | 6.36 | 1165 | 6.67 | 1199 | 6.99 |
| 8500 | G 1099 | 6.47 | G 1133 | 6.79 | 1167 | 7.11 | H 1200 | 7.43 | H 1232 | 7.76 |
| 9000 | 1138 | 7.26 | 1172 | 7.59 | H 1205 | 7.93 | 1237 | 8.26 | 1268 | 8.59 |

LEGEND

Bhp — Brake Horsepower Input to Fan

Boldface indicates field-supplied drive required.

NOTES:

- Motor drive ranges:
(E) Low Range: 685-939, 4.26 Bhp (208/230 and 460-v), 751-954, 5.75 Bhp (575-v)
(F) Mid-Low Range: 949-1206, 5.75 Bhp
(G) Mid-High Range: 941-1176 8.63 Bhp
(H) High Range: 1014-1297, 11.50 Bhp
 All other rpms require field-supplied drive.
- See page 30 for general fan performance notes.

Table 25 — Fan Performance — 50PG24 — Horizontal Supply/Return Units

| AIRFLOW (Cfm) | AVAILABLE EXTERNAL STATIC PRESSURE (in. wg) | | | | | | | | | |
|------------------|---|-------------|------------|-------------|------------|-------------|------------|-------------|------------|-------------|
| | 0.2 | | 0.4 | | 0.6 | | 0.8 | | 1.0 | |
| | Rpm | Bhp | Rpm | Bhp | Rpm | Bhp | Rpm | Bhp | Rpm | Bhp |
| 5,500 | 619 | 1.71 | 682 | 1.96 | 737 | 2.21 | 788 | 2.45 | 837 | 2.71 |
| 6,000 | 663 | 2.09 | 723 | 2.35 | 776 | 2.62 | E 825 | 2.88 | E 871 | 3.14 |
| 6,500 | 708 | 2.53 | E 765 | 2.80 | E 816 | 3.08 | E 863 | 3.35 | E 906 | 3.63 |
| 7,000 | E 753 | 3.02 | 807 | 3.30 | 857 | 3.59 | 902 | 3.88 | 944 | 4.17 |
| 7,500 | 800 | 3.58 | 850 | 3.86 | 898 | 4.16 | 942 | 4.47 | F 982 | 4.77 |
| 8,000 | 847 | 4.20 | 894 | 4.48 | 940 | 4.80 | F 982 | 5.11 | F 1022 | 5.43 |
| 8,500 | 894 | 4.88 | 939 | 5.17 | F 982 | 5.49 | 1024 | 5.82 | 1062 | 6.14 |
| 9,000 | 941 | 5.63 | 983 | 5.92 | 1025 | 6.24 | G 1065 | 6.58 | G 1103 | 6.92 |
| 9,500 | G 989 | 6.45 | G 1029 | 6.74 | G 1069 | 7.07 | G 1108 | 7.41 | G 1144 | 7.77 |
| 10,000 | 1037 | 7.34 | 1075 | 7.63 | 1113 | 7.96 | 1150 | 8.32 | H 1186 | 8.68 |

| AIRFLOW (Cfm) | AVAILABLE EXTERNAL STATIC PRESSURE (in. wg) | | | | | | | | | |
|------------------|---|------|--------|------|--------|------|-------------|--------------|-------------|--------------|
| | 1.2 | | 1.4 | | 1.6 | | 1.8 | | 2.0 | |
| | Rpm | Bhp | Rpm | Bhp | Rpm | Bhp | Rpm | Bhp | Rpm | Bhp |
| 5,500 | E 886 | 2.97 | E 935 | 3.25 | 985 | 3.55 | 1035 | 3.87 | 1086 | 4.21 |
| 6,000 | 916 | 3.41 | 960 | 3.69 | 1005 | 3.98 | F 1050 | 4.29 | F 1096 | 4.61 |
| 6,500 | 949 | 3.90 | F 990 | 4.19 | F 1032 | 4.48 | F 1073 | 4.78 | F 1114 | 5.10 |
| 7,000 | F 984 | 4.46 | F 1023 | 4.75 | 1062 | 5.04 | 1100 | 5.34 | 1139 | 5.66 |
| 7,500 | 1021 | 5.07 | 1059 | 5.37 | 1095 | 5.67 | G 1131 | 5.98 | G 1167 | 6.29 |
| 8,000 | 1059 | 5.74 | 1095 | 6.05 | G 1130 | 6.36 | 1165 | 6.67 | 1199 | 6.99 |
| 8,500 | G 1099 | 6.47 | G 1133 | 6.79 | 1167 | 7.11 | 1200 | 7.43 | H 1232 | 7.76 |
| 9,000 | 1138 | 7.26 | 1172 | 7.59 | 1205 | 7.93 | H 1237 | 8.26 | 1268 | 8.59 |
| 9,500 | H 1179 | 8.12 | H 1212 | 8.46 | H 1244 | 8.81 | 1275 | 9.15 | 1305 | 9.50 |
| 10,000 | 1220 | 9.04 | H 1252 | 9.40 | 1283 | 9.76 | 1313 | 10.11 | 1342 | 10.47 |

LEGEND

Bhp — Brake Horsepower Input to Fan

Boldface indicates field-supplied drive required.

NOTES:

1. Motor drive ranges:

(E) Low Range: 685-939, 4.26 Bhp (208/230 and 460-v), 751-954, 5.75 Bhp (575-v)

(F) Mid-Low Range: 949-1206, 5.75 Bhp

(G) Mid-High Range: 941-1176, 8.63 Bhp

(H) High Range: 1014-1297, 11.50 Bhp

All other rpms require field-supplied motor or drive.

2. See page 30 for general fan performance notes.

Table 26 — Fan Performance — 50PG28 — Horizontal Supply/Return Units

| AIRFLOW (Cfm) | AVAILABLE EXTERNAL STATIC PRESSURE (in. wg) | | | | | | | | | |
|------------------|---|--------------|-------------|--------------|-------------|--------------|-------------|--------------|-------------|--------------|
| | 0.2 | | 0.4 | | 0.6 | | 0.8 | | 1.0 | |
| | Rpm | Bhp | Rpm | Bhp | Rpm | Bhp | Rpm | Bhp | Rpm | Bhp |
| 6,500 | 759 | 2.89 | E 804 | 3.17 | E 844 | 3.42 | 883 | 3.68 | F 922 | 3.96 |
| 7,000 | E 810 | 3.47 | 853 | 3.77 | 891 | 4.04 | F 928 | 4.30 | F 964 | 4.58 |
| 7,500 | 862 | 4.12 | F 903 | 4.43 | F 939 | 4.72 | 974 | 5.00 | 1008 | 5.29 |
| 8,000 | F 913 | 4.84 | 953 | 5.18 | 988 | 5.48 | 1021 | 5.77 | G 1053 | 6.07 |
| 8,500 | 965 | 5.63 | 1003 | 5.99 | 1037 | 6.32 | G 1069 | 6.62 | G 1100 | 6.93 |
| 9,000 | 1017 | 6.50 | G 1054 | 6.89 | G 1087 | 7.23 | G 1118 | 7.55 | 1147 | 7.87 |
| 9,500 | G 1069 | 7.45 | 1105 | 7.86 | 1137 | 8.22 | 1167 | 8.56 | 1195 | 8.89 |
| 10,000 | 1121 | 8.48 | 1156 | 8.92 | H 1187 | 9.30 | H 1216 | 9.66 | H 1243 | 10.01 |
| 10,500 | H 1173 | 9.60 | H 1207 | 10.06 | 1238 | 10.47 | H 1266 | 10.85 | H 1292 | 11.21 |
| 11,000 | 1226 | 10.81 | 1259 | 11.30 | 1288 | 11.72 | 1316 | 12.12 | 1342 | 12.50 |
| 11,500 | 1278 | 12.11 | 1310 | 12.62 | 1339 | 13.07 | 1366 | 13.49 | — | — |
| 12,000 | 1331 | 13.51 | — | — | — | — | — | — | — | — |
| 12,500 | — | — | — | — | — | — | — | — | — | — |

| AIRFLOW (Cfm) | AVAILABLE EXTERNAL STATIC PRESSURE (in. wg) | | | | | | | | | |
|------------------|---|--------------|-------------|--------------|-------------|--------------|-------------|--------------|-------------|--------------|
| | 1.2 | | 1.4 | | 1.6 | | 1.8 | | 2.0 | |
| | Rpm | Bhp | Rpm | Bhp | Rpm | Bhp | Rpm | Bhp | Rpm | Bhp |
| 6,500 | F 962 | 4.27 | F 1003 | 4.61 | 1045 | 4.98 | 1090 | 5.41 | G 1135 | 5.87 |
| 7,000 | 1000 | 4.88 | 1037 | 5.21 | G 1075 | 5.56 | G 1115 | 5.95 | G 1155 | 6.38 |
| 7,500 | 1041 | 5.58 | G 1075 | 5.90 | 1110 | 6.24 | 1145 | 6.61 | 1182 | 7.01 |
| 8,000 | G 1085 | 6.37 | G 1116 | 6.68 | 1148 | 7.01 | 1180 | 7.36 | H 1214 | 7.74 |
| 8,500 | 1129 | 7.23 | 1159 | 7.55 | 1189 | 7.88 | H 1219 | 8.22 | H 1249 | 8.59 |
| 9,000 | 1175 | 8.18 | 1204 | 8.50 | H 1232 | 8.83 | 1260 | 9.18 | 1288 | 9.53 |
| 9,500 | H 1222 | 9.22 | H 1249 | 9.55 | 1276 | 9.88 | 1302 | 10.22 | 1329 | 10.58 |
| 10,000 | 1270 | 10.34 | 1296 | 10.68 | 1321 | 11.02 | 1346 | 11.37 | 1371 | 11.72 |
| 10,500 | 1318 | 11.56 | 1343 | 11.90 | 1367 | 12.25 | 1391 | 12.61 | — | — |
| 11,000 | 1366 | 12.86 | 1390 | 13.22 | — | — | — | — | — | — |
| 11,500 | — | — | — | — | — | — | — | — | — | — |
| 12,000 | — | — | — | — | — | — | — | — | — | — |
| 12,500 | — | — | — | — | — | — | — | — | — | — |

LEGEND

Bhp — Brake Horsepower Input to Fan

Boldface indicates field-supplied motor/drive required.

NOTES:

1. Motor drive ranges:

- (E) Low Range: 687-873, 5.75 Bhp
- (F) Mid-Low Range: 805-1007, 5.75 Bhp
- (G) Mid-High Range: 941-1176, 8.63 Bhp
- (H) High Range: 1014-1297, 11.50 Bhp

All other rpms require field-supplied motor or drive.

2. See below for general fan performance notes.

GENERAL NOTES FOR FAN PERFORMANCE DATA TABLES

1. Static pressure losses from accessories and options (Humidi-MiZer™, economizer, etc.) must be added to external static pressure before entering Fan Performance table. Refer to Tables 31 and 32 for Accessory/FIOP Static Pressure information.
2. Extensive motor and electrical testing on these units ensures that the full range of the motor can be utilized with confidence. Using the fan motors up to the bhp ratings shown will not result in nuisance tripping or premature motor failure. Unit warranty will not be affected. See Tables 29 and 30 (Evaporator-Fan Motor Specifications) on page 31 and 32 for additional information.
3. Use of a field-supplied motor may affect wire sizing. Contact your local Carrier representative for details.
4. Interpolation is permissible. Do not extrapolate.

Table 27 — Air Quantity Limits (48PG20-28 Units)

| 48PG | COOLING | | GAS HEAT | HEATING (NAT. GAS, VERTICAL) MINIMUM CFM | HEATING (NAT. GAS, HORIZONTAL) MINIMUM CFM | HEATING (PROPANE, VERTICAL) MINIMUM CFM | HEATING (PROPANE, HORIZONTAL) MINIMUM CFM |
|------|-------------|-------------|----------------------|---|---|--|--|
| | Minimum Cfm | Maximum Cfm | | | | | |
| 20 | 5000 | 9,000 | High Heat (8 Cell) | 5522 | 5522 | 5522 | 4920 |
| | | | Medium Heat (8 Cell) | 4977 | 4977 | 4480 | 4480 |
| | | | Low Heat (5 Cell) | 4218 | 4218 | 4218 | 3796 |
| 24 | 5500 | 10,000 | High Heat (8 Cell) | 5522 | 5522 | 5522 | 4920 |
| | | | Medium Heat (8 Cell) | 4977 | 4977 | 4480 | 4480 |
| | | | Low Heat (5 Cell) | 4218 | 4218 | 4218 | 3796 |
| 28 | 6500 | 12,000 | High Heat (8 Cell) | 5522 | 5470* | 5522 | 4920* |
| | | | Medium Heat (8 Cell) | 4977 | 4977* | 4480 | 4480* |
| | | | Low Heat (5 Cell) | 4218 | 4218 | 4218 | 3796 |

*7000 cfm minimum recommended above 1.0 in. wg external static pressure.

Table 28 — Air Quantity Limits (50PG20-28 Units)

| 50PG | COOLING | | ELECTRIC HEAT | ELECTRIC HEAT (Vertical) MINIMUM CFM | ELECTRIC HEAT (Horizontal) MINIMUM CFM |
|------|-------------|-------------|---------------------|--------------------------------------|--|
| | Minimum Cfm | Maximum Cfm | | | |
| 20 | 5000 | 9,000 | High Heat (75 kW) | 4,500 | 5,400 |
| | | | Medium Heat (50 kW) | 3,750 | 4,800 |
| | | | Low Heat (25 kW) | 3,750 | 3,750 |
| 24 | 5500 | 10,000 | High Heat (75 kW) | 4,500 | 5,400 |
| | | | Medium Heat (50 kW) | 3,750 | 4,800 |
| | | | Low Heat (25 kW) | 3,750 | 3,750 |
| 28 | 6500 | 12,000 | High Heat (75 kW) | 4,500 | 5,400 |
| | | | Medium Heat (50 kW) | 3,750 | 4,800 |
| | | | Low Heat (25 kW) | 3,750 | 3,750 |

Table 29 — Evaporator Fan Motor Specifications — 48PG20-28 Units

| UNIT 48PG | DRIVE | ORIENTATION | NOMINAL HP | VOLTAGE | MAX WATTS | EFFICIENCY % | MAX BHP | MAX Bkw | MAX AMPS | |
|-----------|----------|-------------|------------|---------|-----------|--------------|---------|---------|----------|------|
| 20 | Low | Vertical | 3.7 | 208 | 3700 | 85.8 | 4.26 | 3.17 | 10.6 | |
| | | | 3.7 | 230 | 3700 | 85.8 | 4.26 | 3.17 | 9.6 | |
| | | | 3.7 | 460 | 3700 | 85.8 | 4.26 | 3.17 | 4.8 | |
| | Mid-Low | Vertical | 5 | 575 | 5015 | 87.5 | 5.88 | 4.39 | 6.0 | |
| | | | 5 | 208 | 4578 | 87.5 | 5.37 | 4.01 | 15.8 | |
| | | | 5 | 230 | 5115 | 87.5 | 6.00 | 4.48 | 15.4 | |
| | | | 5 | 460 | 5115 | 87.5 | 6.00 | 4.48 | 7.7 | |
| | | | 5 | 575 | 5015 | 87.5 | 5.88 | 4.39 | 6.0 | |
| | | | 7.5 | 208 | 6458 | 88.5 | 7.66 | 5.71 | 22.0 | |
| | Mid-High | Vertical | 7.5 | 230 | 7169 | 88.5 | 8.51 | 6.34 | 22.0 | |
| | | | 7.5 | 460 | 7586 | 88.5 | 9.00 | 6.71 | 11.6 | |
| | | | 7.5 | 575 | 7586 | 88.5 | 9.00 | 6.71 | 9.4 | |
| | | | 10 | 208 | 8284 | 89.5 | 9.94 | 7.41 | 28.0 | |
| | High | Vertical | 10 | 230 | 8708 | 89.5 | 10.45 | 7.79 | 28.0 | |
| | | | 10 | 460 | 9330 | 89.5 | 11.19 | 8.35 | 15.0 | |
| | | | 10 | 575 | 9711 | 89.5 | 11.65 | 8.69 | 12.0 | |
| | Low | Horizontal | N/A | 208 | N/A | N/A | N/A | N/A | N/A | |
| | | | N/A | 230 | N/A | N/A | N/A | N/A | N/A | |
| | | | N/A | 460 | N/A | N/A | N/A | N/A | N/A | |
| | | | N/A | 575 | N/A | N/A | N/A | N/A | N/A | |
| | Mid-Low | Horizontal | 3.7 | 208 | 3700 | 85.8 | 4.26 | 3.17 | 10.6 | |
| | | | 3.7 | 230 | 3700 | 85.8 | 4.26 | 3.17 | 9.6 | |
| | | | 3.7 | 460 | 3700 | 85.8 | 4.26 | 3.17 | 4.8 | |
| | Mid-High | Horizontal | 5 | 575 | 5015 | 87.5 | 5.88 | 4.39 | 6.0 | |
| | | | 5 | 208 | 4578 | 87.5 | 5.37 | 4.01 | 15.8 | |
| | | | 5 | 230 | 5115 | 87.5 | 6.00 | 4.48 | 15.4 | |
| | | | 5 | 460 | 5115 | 87.5 | 6.00 | 4.48 | 7.7 | |
| | | | 5 | 575 | 5015 | 87.5 | 5.88 | 4.39 | 6.0 | |
| | | | 7.5 | 208 | 6458 | 88.5 | 7.66 | 5.71 | 22.0 | |
| | High | Horizontal | 7.5 | 230 | 7169 | 88.5 | 8.51 | 6.34 | 22.0 | |
| | | | 7.5 | 460 | 7586 | 88.5 | 9.00 | 6.71 | 11.6 | |
| | | | 7.5 | 575 | 7586 | 88.5 | 9.00 | 6.71 | 9.4 | |
| | | | 10 | 208 | 8284 | 89.5 | 9.94 | 7.41 | 28.0 | |
| | 24 | Low | Vertical | 3.7 | 208 | 3700 | 85.8 | 4.26 | 3.17 | 10.6 |
| | | | | 3.7 | 230 | 3700 | 85.8 | 4.26 | 3.17 | 9.6 |
| | | | | 3.7 | 460 | 3700 | 85.8 | 4.26 | 3.17 | 4.8 |
| Mid-Low | | Vertical | 5 | 575 | 5015 | 87.5 | 5.88 | 4.39 | 6.0 | |
| | | | 5 | 208 | 4578 | 87.5 | 5.37 | 4.01 | 15.8 | |
| | | | 5 | 230 | 5115 | 87.5 | 6.00 | 4.48 | 15.4 | |
| | | | 5 | 460 | 5115 | 87.5 | 6.00 | 4.48 | 7.7 | |
| | | | 5 | 575 | 5015 | 87.5 | 5.88 | 4.39 | 6.0 | |
| | | | 7.5 | 208 | 6458 | 88.5 | 7.66 | 5.71 | 22.0 | |
| Mid-High | | Vertical | 7.5 | 230 | 7169 | 88.5 | 8.51 | 6.34 | 22.0 | |
| | | | 7.5 | 460 | 7586 | 88.5 | 9.00 | 6.71 | 11.6 | |
| | | | 7.5 | 575 | 7586 | 88.5 | 9.00 | 6.71 | 9.4 | |
| | | | 10 | 208 | 8284 | 89.5 | 9.94 | 7.41 | 28.0 | |
| High | | Vertical | 10 | 230 | 8708 | 89.5 | 10.45 | 7.79 | 28.0 | |
| | | | 10 | 460 | 9330 | 89.5 | 11.19 | 8.35 | 15.0 | |
| | | | 10 | 575 | 9711 | 89.5 | 11.65 | 8.69 | 12.0 | |
| Low | | Horizontal | N/A | 208 | N/A | N/A | N/A | N/A | N/A | |
| | | | N/A | 230 | N/A | N/A | N/A | N/A | N/A | |
| | | | N/A | 460 | N/A | N/A | N/A | N/A | N/A | |
| | | | N/A | 575 | N/A | N/A | N/A | N/A | N/A | |
| Mid-Low | | Horizontal | 3.7 | 208 | 3700 | 85.8 | 4.26 | 3.17 | 10.6 | |
| | | | 3.7 | 230 | 3700 | 85.8 | 4.26 | 3.17 | 9.6 | |
| | | | 3.7 | 460 | 3700 | 85.8 | 4.26 | 3.17 | 4.8 | |
| Mid-High | | Horizontal | 5 | 575 | 5015 | 87.5 | 5.88 | 4.39 | 6.0 | |
| | | | 5 | 208 | 4578 | 87.5 | 5.37 | 4.01 | 15.8 | |
| | | | 5 | 230 | 5115 | 87.5 | 6.00 | 4.48 | 15.4 | |
| | | | 5 | 460 | 5115 | 87.5 | 6.00 | 4.48 | 7.7 | |
| | | | 5 | 575 | 5015 | 87.5 | 5.88 | 4.39 | 6.0 | |
| | | | 7.5 | 208 | 6458 | 88.5 | 7.66 | 5.71 | 22.0 | |
| High | | Horizontal | 7.5 | 230 | 7169 | 88.5 | 8.51 | 6.34 | 22.0 | |
| | | | 7.5 | 460 | 7586 | 88.5 | 9.00 | 6.71 | 11.6 | |
| | | | 7.5 | 575 | 7586 | 88.5 | 9.00 | 6.71 | 9.4 | |
| | | | 10 | 208 | 8284 | 89.5 | 9.94 | 7.41 | 28.0 | |

Table 29 — Evaporator Fan Motor Specifications — 48PG20-28 Units (cont)

| UNIT 48PG | DRIVE | ORIENTATION | NOMINAL HP | VOLTAGE | MAX WATTS | EFFICIENCY % | MAX BHP | MAX BkW | MAX AMPS |
|--------------|----------|-------------|------------|---------|-----------|--------------|---------|---------|----------|
| 28 | Low | Vertical | 5 | 208 | 4578 | 87.5 | 5.37 | 4.01 | 15.8 |
| | | | 5 | 230 | 5115 | 87.5 | 6.00 | 4.48 | 15.4 |
| | | | 5 | 460 | 5115 | 87.5 | 6.00 | 4.48 | 7.7 |
| | | | 5 | 575 | 5015 | 87.5 | 5.88 | 4.39 | 6.0 |
| | Mid-Low | Vertical | 5 | 208 | 4578 | 87.5 | 5.37 | 4.01 | 15.8 |
| | | | 5 | 230 | 5115 | 87.5 | 6.00 | 4.48 | 15.4 |
| | | | 5 | 460 | 5115 | 87.5 | 6.00 | 4.48 | 7.7 |
| | | | 5 | 575 | 5015 | 87.5 | 5.88 | 4.39 | 6.0 |
| | Mid-High | Vertical | 7.5 | 208 | 6458 | 88.5 | 7.66 | 5.71 | 22.0 |
| | | | 7.5 | 230 | 7169 | 88.5 | 8.51 | 6.34 | 22.0 |
| | | | 7.5 | 460 | 7586 | 88.5 | 9.00 | 6.71 | 11.6 |
| | | | 7.5 | 575 | 7586 | 88.5 | 9.00 | 6.71 | 9.4 |
| | High | Vertical | 10 | 208 | 8284 | 89.5 | 9.94 | 7.41 | 28.0 |
| | | | 10 | 230 | 8708 | 89.5 | 10.45 | 7.79 | 28.0 |
| | | | 10 | 460 | 9330 | 89.5 | 11.19 | 8.35 | 15.0 |
| | | | 10 | 575 | 9711 | 89.5 | 11.65 | 8.69 | 12.0 |
| | Low | Horizontal | 5 | 208 | 4578 | 87.5 | 5.37 | 4.01 | 15.8 |
| | | | 5 | 230 | 5115 | 87.5 | 6.00 | 4.48 | 15.4 |
| | | | 5 | 460 | 5115 | 87.5 | 6.00 | 4.48 | 7.7 |
| | | | 5 | 575 | 5015 | 87.5 | 5.88 | 4.39 | 6.0 |
| | Mid-Low | Horizontal | 5 | 208 | 4578 | 87.5 | 5.37 | 4.01 | 15.8 |
| | | | 5 | 230 | 5115 | 87.5 | 6.00 | 4.48 | 15.4 |
| | | | 5 | 460 | 5115 | 87.5 | 6.00 | 4.48 | 7.7 |
| | | | 5 | 575 | 5015 | 87.5 | 5.88 | 4.39 | 6.0 |
| | Mid-High | Horizontal | 7.5 | 208 | 6458 | 88.5 | 7.66 | 5.71 | 22.0 |
| | | | 7.5 | 230 | 7169 | 88.5 | 8.51 | 6.34 | 22.0 |
| | | | 7.5 | 460 | 7586 | 88.5 | 9.00 | 6.71 | 11.6 |
| | | | 7.5 | 575 | 7586 | 88.5 | 9.00 | 6.71 | 9.4 |
| | High | Horizontal | 10 | 208 | 8284 | 89.5 | 9.94 | 7.41 | 28.0 |
| | | | 10 | 230 | 8708 | 89.5 | 10.45 | 7.79 | 28.0 |
| | | | 10 | 460 | 9330 | 89.5 | 11.19 | 8.35 | 15.0 |
| | | | 10 | 575 | 9711 | 89.5 | 11.65 | 8.69 | 12.0 |

NOTES:

- Extensive motor and electrical testing ensures that the motors can be utilized with confidence up to the maximum applied bhp, watts, and amps. Using the fan motor up to the maximum ratings shown will not result in nuisance tripping or premature motor failure. Unit warranty will not be affected.
- All indoor-fan motors 5 hp and larger meet the minimum efficiency requirements as established by the Energy Policy Act of 1992 (EPACT) effective October 24, 1997.

- Convert bhp to watts using the following formula:

$$\text{watts} = \frac{\text{bhp (746)}}{\text{motor efficiency}}$$

Table 30 — Evaporator Fan Motor Specifications — 50PG20-28 Units

| UNIT 50PG | DRIVE | ORIENTATION | NOMINAL HP | VOLTAGE | MAX WATTS | EFFICIENCY % | MAX BHP | MAX BkW | MAX AMPS |
|--------------|----------|-------------|------------|---------|-----------|--------------|---------|---------|----------|
| 20 | Low | Vertical | 3.7 | 208 | 3700 | 85.8 | 4.26 | 3.17 | 10.6 |
| | | | 3.7 | 230 | 3700 | 85.8 | 4.26 | 3.17 | 9.6 |
| | | | 3.7 | 460 | 3700 | 85.8 | 4.26 | 3.17 | 4.8 |
| | | | 5 | 575 | 5015 | 87.5 | 5.88 | 4.39 | 6.0 |
| | Mid-Low | Vertical | 5 | 208 | 4578 | 87.5 | 5.37 | 4.01 | 15.8 |
| | | | 5 | 230 | 5115 | 87.5 | 6.00 | 4.48 | 15.4 |
| | | | 5 | 460 | 5115 | 87.5 | 6.00 | 4.48 | 7.7 |
| | | | 5 | 575 | 5015 | 87.5 | 5.88 | 4.39 | 6.0 |
| | Mid-High | Vertical | 7.5 | 208 | 6458 | 88.5 | 7.66 | 5.71 | 22.0 |
| | | | 7.5 | 230 | 7169 | 88.5 | 8.51 | 6.34 | 22.0 |
| | | | 7.5 | 460 | 7586 | 88.5 | 9.00 | 6.71 | 11.6 |
| | | | 7.5 | 575 | 7586 | 88.5 | 9.00 | 6.71 | 9.4 |
| | High | Vertical | 10 | 208 | 8284 | 89.5 | 9.94 | 7.41 | 28.0 |
| | | | 10 | 230 | 8708 | 89.5 | 10.45 | 7.79 | 28.0 |
| | | | 10 | 460 | 9330 | 89.5 | 11.19 | 8.35 | 15.0 |
| | | | 10 | 575 | 9711 | 89.5 | 11.65 | 8.69 | 12.0 |
| | Low | Horizontal | 3.7 | 208 | 3700 | 85.8 | 4.26 | 3.17 | 10.6 |
| | | | 3.7 | 230 | 3700 | 85.8 | 4.26 | 3.17 | 9.6 |
| | | | 3.7 | 460 | 3700 | 85.8 | 4.26 | 3.17 | 4.8 |
| | | | 5 | 575 | 5015 | 87.5 | 5.88 | 4.39 | 6.0 |
| | Mid-Low | Horizontal | 5 | 208 | 4578 | 87.5 | 5.37 | 4.01 | 15.8 |
| | | | 5 | 230 | 5115 | 87.5 | 6.00 | 4.48 | 15.4 |
| | | | 5 | 460 | 5115 | 87.5 | 6.00 | 4.48 | 7.7 |
| | | | 5 | 575 | 5015 | 87.5 | 5.88 | 4.39 | 6.0 |
| | Mid-High | Horizontal | 7.5 | 208 | 6458 | 88.5 | 7.66 | 5.71 | 22.0 |
| | | | 7.5 | 230 | 7169 | 88.5 | 8.51 | 6.34 | 22.0 |
| | | | 7.5 | 460 | 7586 | 88.5 | 9.00 | 6.71 | 11.6 |
| | | | 7.5 | 575 | 7586 | 88.5 | 9.00 | 6.71 | 9.4 |
| | High | Horizontal | 10 | 208 | 8284 | 89.5 | 9.94 | 7.41 | 28.0 |
| | | | 10 | 230 | 8708 | 89.5 | 10.45 | 7.79 | 28.0 |
| | | | 10 | 460 | 9330 | 89.5 | 11.19 | 8.35 | 15.0 |
| | | | 10 | 575 | 9711 | 89.5 | 11.65 | 8.69 | 12.0 |

NOTES:

- Extensive motor and electrical testing ensures that the motors can be utilized with confidence up to the maximum applied bhp, watts, and amps. Using the fan motor up to the maximum ratings shown will not result in nuisance tripping or premature motor failure. Unit warranty will not be affected.

- All indoor-fan motors 5 hp and larger meet the minimum efficiency requirements as established by the Energy Policy Act of 1992 (EPACT) effective October 24, 1997.
- Convert bhp to watts using the following formula:

$$\text{watts} = \frac{\text{bhp (746)}}{\text{motor efficiency}}$$

Table 30 — Evaporator Fan Motor Specifications — 50PG20-28 Units (cont)

| UNIT 50PG | DRIVE | ORIENTATION | NOMINAL HP | VOLTAGE | MAX WATTS | EFFICIENCY % | MAX BHP | MAX BkW | MAX AMPS |
|--------------|------------|-------------|------------|---------|-----------|--------------|---------|---------|----------|
| 24 | Low | Vertical | 3.7 | 208 | 3700 | 85.8 | 4.26 | 3.17 | 10.6 |
| | | | 3.7 | 230 | 3700 | 85.8 | 4.26 | 3.17 | 9.6 |
| | | | 3.7 | 460 | 3700 | 85.8 | 4.26 | 3.17 | 4.8 |
| | | | 5 | 575 | 5015 | 87.5 | 5.88 | 4.39 | 6.0 |
| | Mid-Low | Vertical | 5 | 208 | 4578 | 87.5 | 5.37 | 4.01 | 15.8 |
| | | | 5 | 230 | 5115 | 87.5 | 6.00 | 4.48 | 15.4 |
| | | | 5 | 460 | 5115 | 87.5 | 6.00 | 4.48 | 7.7 |
| | | | 5 | 575 | 5015 | 87.5 | 5.88 | 4.39 | 6.0 |
| | Mid-High | Vertical | 7.5 | 208 | 6458 | 88.5 | 7.66 | 5.71 | 22.0 |
| | | | 7.5 | 230 | 7169 | 88.5 | 8.51 | 6.34 | 22.0 |
| | | | 7.5 | 460 | 7586 | 88.5 | 9.00 | 6.71 | 11.6 |
| | | | 7.5 | 575 | 7586 | 88.5 | 9.00 | 6.71 | 9.4 |
| | High | Vertical | 10 | 208 | 8284 | 89.5 | 9.94 | 7.41 | 28.0 |
| | | | 10 | 230 | 8708 | 89.5 | 10.45 | 7.79 | 28.0 |
| | | | 10 | 460 | 9330 | 89.5 | 11.19 | 8.35 | 15.0 |
| | | | 10 | 575 | 9711 | 89.5 | 11.65 | 8.69 | 12.0 |
| | Low | Horizontal | 3.7 | 208 | 3700 | 85.8 | 4.26 | 3.17 | 10.6 |
| | | | 3.7 | 230 | 3700 | 85.8 | 4.26 | 3.17 | 9.6 |
| | | | 3.7 | 460 | 3700 | 85.8 | 4.26 | 3.17 | 4.8 |
| | | | 5 | 575 | 5015 | 87.5 | 5.88 | 4.39 | 6.0 |
| | Mid-Low | Horizontal | 5 | 208 | 4578 | 87.5 | 5.37 | 4.01 | 15.8 |
| | | | 5 | 230 | 5115 | 87.5 | 6.00 | 4.48 | 15.4 |
| | | | 5 | 460 | 5115 | 87.5 | 6.00 | 4.48 | 7.7 |
| | | | 5 | 575 | 5015 | 87.5 | 5.88 | 4.39 | 6.0 |
| Mid-High | Horizontal | 7.5 | 208 | 6458 | 88.5 | 7.66 | 5.71 | 22.0 | |
| | | 7.5 | 230 | 7169 | 88.5 | 8.51 | 6.34 | 22.0 | |
| | | 7.5 | 460 | 7586 | 88.5 | 9.00 | 6.71 | 11.6 | |
| | | 7.5 | 575 | 7586 | 88.5 | 9.00 | 6.71 | 9.4 | |
| High | Horizontal | 10 | 208 | 8284 | 89.5 | 9.94 | 7.41 | 28.0 | |
| | | 10 | 230 | 8708 | 89.5 | 10.45 | 7.79 | 28.0 | |
| | | 10 | 460 | 9330 | 89.5 | 11.19 | 8.35 | 15.0 | |
| | | 10 | 575 | 9711 | 89.5 | 11.65 | 8.69 | 12.0 | |
| 28 | Low | Vertical | 5 | 208 | 4578 | 87.5 | 5.37 | 4.01 | 15.8 |
| | | | 5 | 230 | 5115 | 87.5 | 6.00 | 4.48 | 15.4 |
| | | | 5 | 460 | 5115 | 87.5 | 6.00 | 4.48 | 7.7 |
| | | | 5 | 575 | 5015 | 87.5 | 5.88 | 4.39 | 6.0 |
| | Mid-Low | Vertical | 5 | 208 | 4578 | 87.5 | 5.37 | 4.01 | 15.8 |
| | | | 5 | 230 | 5115 | 87.5 | 6.00 | 4.48 | 15.4 |
| | | | 5 | 460 | 5115 | 87.5 | 6.00 | 4.48 | 7.7 |
| | | | 5 | 575 | 5015 | 87.5 | 5.88 | 4.39 | 6.0 |
| | Mid-High | Vertical | 7.5 | 208 | 6458 | 88.5 | 7.66 | 5.71 | 22.0 |
| | | | 7.5 | 230 | 7169 | 88.5 | 8.51 | 6.34 | 22.0 |
| | | | 7.5 | 460 | 7586 | 88.5 | 9.00 | 6.71 | 11.6 |
| | | | 7.5 | 575 | 7586 | 88.5 | 9.00 | 6.71 | 9.4 |
| | High | Vertical | 10 | 208 | 8284 | 89.5 | 9.94 | 7.41 | 28.0 |
| | | | 10 | 230 | 8708 | 89.5 | 10.45 | 7.79 | 28.0 |
| | | | 10 | 460 | 9330 | 89.5 | 11.19 | 8.35 | 15.0 |
| | | | 10 | 575 | 9711 | 89.5 | 11.65 | 8.69 | 12.0 |
| | Low | Horizontal | 5 | 208 | 4578 | 87.5 | 5.37 | 4.01 | 15.8 |
| | | | 5 | 230 | 5115 | 87.5 | 6.00 | 4.48 | 15.4 |
| | | | 5 | 460 | 5115 | 87.5 | 6.00 | 4.48 | 7.7 |
| | | | 5 | 575 | 5015 | 87.5 | 5.88 | 4.39 | 6.0 |
| | Mid-Low | Horizontal | 5 | 208 | 4578 | 87.5 | 5.37 | 4.01 | 15.8 |
| | | | 5 | 230 | 5115 | 87.5 | 6.00 | 4.48 | 15.4 |
| | | | 5 | 460 | 5115 | 87.5 | 6.00 | 4.48 | 7.7 |
| | | | 5 | 575 | 5015 | 87.5 | 5.88 | 4.39 | 6.0 |
| Mid-High | Horizontal | 7.5 | 208 | 6458 | 88.5 | 7.66 | 5.71 | 22.0 | |
| | | 7.5 | 230 | 7169 | 88.5 | 8.51 | 6.34 | 22.0 | |
| | | 7.5 | 460 | 7586 | 88.5 | 9.00 | 6.71 | 11.6 | |
| | | 7.5 | 575 | 7586 | 88.5 | 9.00 | 6.71 | 9.4 | |
| High | Horizontal | 10 | 208 | 8284 | 89.5 | 9.94 | 7.41 | 28.0 | |
| | | 10 | 230 | 8708 | 89.5 | 10.45 | 7.79 | 28.0 | |
| | | 10 | 460 | 9330 | 89.5 | 11.19 | 8.35 | 15.0 | |
| | | 10 | 575 | 9711 | 89.5 | 11.65 | 8.69 | 12.0 | |

NOTES:

1. Extensive motor and electrical testing ensures that the motors can be utilized with confidence up to the maximum applied bhp, watts, and amps. Using the fan motor up to the maximum ratings shown will not result in nuisance tripping or premature motor failure. Unit warranty will not be affected.

- 2. All indoor-fan motors 5 hp and larger meet the minimum efficiency requirements as established by the Energy Policy Act of 1992 (EPACT) effective October 24, 1997.
- 3. Convert bhp to watts using the following formula:

$$\text{watts} = \frac{\text{bhp (746)}}{\text{motor efficiency}}$$

Table 31 — Accessory/FIOP Static Pressure (in. wg)* — 48/50PG20-28 Units

| COMPONENT | CFM | | | | | | | | |
|------------------------|-------|-------|-------|-------|-------|-------|-------|-------|-------|
| | 4,000 | 4,500 | 5,000 | 5,500 | 6,000 | 6,500 | 7,000 | 7,500 | 8,000 |
| Economizer | 0.02 | 0.03 | 0.04 | 0.05 | 0.06 | 0.07 | 0.08 | 0.09 | 0.10 |
| Humidi-MiZer™ (20, 24) | — | — | — | 0.10 | 0.17 | 0.25 | 0.32 | 0.40 | 0.47 |
| Humidi-MiZer (28) | — | — | — | — | — | 0.05 | 0.13 | 0.21 | 0.29 |

| COMPONENT | CFM | | | | | | | | |
|-----------------------|-------|-------|-------|--------|--------|--------|--------|--------|--|
| | 8,500 | 9,000 | 9,500 | 10,000 | 10,500 | 11,000 | 11,500 | 12,000 | |
| Economizer | 0.11 | 0.12 | 0.13 | 0.15 | 0.16 | 0.17 | 0.19 | 0.20 | |
| Humidi-MiZer (20, 24) | 0.54 | 0.60 | 0.68 | 0.74 | — | — | — | — | |
| Humidi-MiZer (28) | 0.38 | 0.44 | 0.51 | 0.59 | 0.66 | 0.72 | 0.80 | 0.86 | |

LEGEND
 FIOP — Factory-Installed Option

*The static pressure must be added to the external static pressure. The sum and the evaporator entering-air cfm should then be used in conjunction with the Fan Performance tables to determine blower rpm and watts.

Table 32 — Accessory/FIOP Electric Heat Static Pressure (in. wg) — 50PG20-28 Units

| UNIT 50PG | ELECTRIC HEATERS | | | | | | | |
|------------|------------------|--------|--------------------------|------------------------|--------------------------|------------------------|--------------------------|------------------------|
| | Unit Voltages | Cfm | Nominal Heater Size (kW) | Pressure Drop (in. wg) | Nominal Heater Size (kW) | Pressure Drop (in. wg) | Nominal Heater Size (kW) | Pressure Drop (in. wg) |
| 20, 24, 28 | 208/240 | | | | | | | |
| | | 5,000 | 0.01 | 0.04 | | | | |
| | | 6,000 | 0.02 | 0.06 | | | | |
| | | 7,000 | 0.03 | 0.08 | | | | |
| | | 8,000 | 0.04 | 0.12 | | | | |
| | | 9,000 | 0.05 | 0.15 | | | | |
| | | 10,000 | 0.06 | 0.20 | | | | |
| | | 11,500 | 0.09 | 0.27 | | | | |
| | | 4,800 | 0.01 | 0.03 | | | | |
| | | 5,000 | 0.01 | 0.04 | | | | |
| | | 6,000 | 0.02 | 0.06 | | | | |
| | | 7,000 | 0.03 | 0.08 | | | | |
| | 8,000 | 0.04 | 0.12 | | | | | |
| | 9,000 | 0.05 | 0.15 | | | | | |
| | 10,000 | 0.06 | 0.20 | | | | | |
| | 11,500 | 0.09 | 0.27 | | | | | |
| | 4,800 | 0.01 | 0.03 | | | | | |
| | 5,000 | 0.01 | 0.04 | | | | | |
| | 6,000 | 0.02 | 0.06 | | | | | |
| | 7,000 | 0.03 | 0.08 | | | | | |
| | 8,000 | 0.04 | 0.12 | | | | | |
| | 9,000 | 0.05 | 0.15 | | | | | |
| | 10,000 | 0.06 | 0.20 | | | | | |
| | 11,500 | 0.09 | 0.27 | | | | | |

LEGEND
 FIOP — Factory-Installed Option

NOTES:
 1. Heaters are rated at 240 v, 480 v, and 600 v.
 2. The static pressure must be added to external static pressure. The sum and the evaporator entering-air cfm should then be used in conjunction with the Fan Performance table to determine blower rpm, bhp, and watts.

Table 33 — Fan RPM At Motor Pulley Settings* — 48PG20-28 Units

| UNIT 48PG | DRIVE | MOTOR PULLEY TURNS OPEN | | | | | | | | | | | | | | |
|------------------------------|----------------------|-------------------------|----------|------|-------|------|-------|------|-------|------|-------|------|-------|------|------|------|
| | | 0 | 1/2 | 1 | 1 1/2 | 2 | 2 1/2 | 3 | 3 1/2 | 4 | 4 1/2 | 5 | 5 1/2 | 6 | | |
| 20 and 24 (230 and 460 volt) | Vertical | Low | 685 | 706 | 727 | 749 | 770 | 791 | 812 | 833 | 854 | 876 | 897 | 918 | 939 | |
| | | Mid-Low | 949 | 970 | 992 | 1013 | 1035 | 1056 | 1078 | 1099 | 1120 | 1142 | 1163 | 1185 | 1206 | |
| | | Mid-High | 941 | 961 | 980 | 1000 | 1019 | 1039 | 1059 | 1078 | 1098 | 1117 | 1137 | 1156 | 1176 | |
| | | High | 1014 | 1038 | 1061 | 1085 | 1108 | 1132 | 1156 | 1179 | 1203 | 1226 | 1250 | 1273 | 1297 | |
| | Horizontal | Low | n/a | n/a | n/a | n/a | n/a | n/a | n/a | n/a | n/a | n/a | n/a | n/a | n/a | |
| | | Mid-Low | 896 | 924 | 951 | 979 | 1006 | 1034 | 1062 | 1089 | 1117 | 1144 | 1172 | 1199 | 1227 | |
| | | Mid-High | 1113 | 1138 | 1163 | 1188 | 1213 | 1238 | 1264 | 1289 | 1314 | 1339 | 1364 | 1389 | 1414 | |
| | | High | 1096 | 1116 | 1137 | 1157 | 1177 | 1197 | 1218 | 1238 | 1258 | 1278 | 1299 | 1319 | 1339 | |
| | 20 and 24 (575 volt) | Vertical | Low | 751 | 768 | 785 | 802 | 819 | 836 | 853 | 869 | 886 | 903 | 920 | 937 | 954 |
| | | | Mid-Low | 949 | 970 | 992 | 1013 | 1035 | 1056 | 1078 | 1099 | 1120 | 1142 | 1163 | 1185 | 1206 |
| | | | Mid-High | 941 | 961 | 980 | 1000 | 1019 | 1039 | 1059 | 1078 | 1098 | 1117 | 1137 | 1156 | 1176 |
| | | | High | 1014 | 1038 | 1061 | 1085 | 1108 | 1132 | 1156 | 1179 | 1203 | 1226 | 1250 | 1273 | 1297 |
| Horizontal | | Low | n/a | n/a | n/a | n/a | n/a | n/a | n/a | n/a | n/a | n/a | n/a | n/a | n/a | |
| | | Mid-Low | 873 | 893 | 912 | 932 | 951 | 971 | 991 | 1010 | 1030 | 1049 | 1069 | 1088 | 1108 | |
| | | Mid-High | 1113 | 1138 | 1163 | 1188 | 1213 | 1238 | 1264 | 1289 | 1314 | 1339 | 1364 | 1389 | 1414 | |
| | | High | 1096 | 1116 | 1137 | 1157 | 1177 | 1197 | 1218 | 1238 | 1258 | 1278 | 1299 | 1319 | 1339 | |
| 28 (all voltages) | | Vertical | Low | 687 | 703 | 718 | 734 | 749 | 765 | 780 | 796 | 811 | 827 | 842 | 858 | 873 |
| | | | Mid-Low | 805 | 822 | 839 | 856 | 872 | 889 | 906 | 923 | 940 | 957 | 973 | 990 | 1007 |
| | | | Mid-High | 941 | 961 | 980 | 1000 | 1019 | 1039 | 1059 | 1078 | 1098 | 1117 | 1137 | 1156 | 1176 |
| | | | High | 1014 | 1038 | 1061 | 1085 | 1108 | 1132 | 1156 | 1179 | 1203 | 1226 | 1250 | 1273 | 1297 |
| | Horizontal | Low | 687 | 703 | 718 | 734 | 749 | 765 | 780 | 796 | 811 | 827 | 842 | 858 | 873 | |
| | | Mid-Low | 805 | 822 | 839 | 856 | 872 | 889 | 906 | 923 | 940 | 957 | 973 | 990 | 1007 | |
| | | Mid-High | 941 | 961 | 980 | 1000 | 1019 | 1039 | 1059 | 1078 | 1098 | 1117 | 1137 | 1156 | 1176 | |
| | | High | 1014 | 1038 | 1061 | 1085 | 1108 | 1132 | 1156 | 1179 | 1203 | 1226 | 1250 | 1273 | 1297 | |

*Approximate fan rpm shown.

NOTE: Factory pulley speed setting is at 3 turns open.

Table 34 — Fan Rpm At Motor Pulley Settings* — 50PG20-28

| 50PG | DRIVE | MOTOR PULLEY TURNS OPEN | | | | | | | | | | | | |
|---------------------------------|---------------------------|-------------------------|------|------|-------|------|-------|------|-------|------|-------|------|-------|------|
| | | 0 | 1/2 | 1 | 1 1/2 | 2 | 2 1/2 | 3 | 3 1/2 | 4 | 4 1/2 | 5 | 5 1/2 | 6 |
| 20 and 24 (230 and 460 volt) | Low Range Vertical | 685 | 706 | 727 | 749 | 770 | 791 | 812 | 833 | 854 | 876 | 897 | 918 | 939 |
| | Mid-Low Range Vertical | 949 | 970 | 992 | 1013 | 1035 | 1056 | 1078 | 1099 | 1120 | 1142 | 1163 | 1185 | 1206 |
| | Mid-High Range Vertical | 941 | 961 | 980 | 1000 | 1019 | 1039 | 1059 | 1078 | 1098 | 1117 | 1137 | 1156 | 1176 |
| | High Range Vertical | 1014 | 1038 | 1061 | 1085 | 1108 | 1132 | 1156 | 1179 | 1203 | 1226 | 1250 | 1273 | 1297 |
| | Low Range Horizontal | 685 | 706 | 727 | 749 | 770 | 791 | 812 | 833 | 854 | 876 | 897 | 918 | 939 |
| | Mid-Low Range Horizontal | 949 | 970 | 992 | 1013 | 1035 | 1056 | 1078 | 1099 | 1120 | 1142 | 1163 | 1185 | 1206 |
| | Mid-High Range Horizontal | 941 | 961 | 980 | 1000 | 1019 | 1039 | 1059 | 1078 | 1098 | 1117 | 1137 | 1156 | 1176 |
| | High Range Horizontal | 1014 | 1038 | 1061 | 1085 | 1108 | 1132 | 1156 | 1179 | 1203 | 1226 | 1250 | 1273 | 1297 |
| | Low Range Vertical | 751 | 768 | 785 | 802 | 819 | 836 | 853 | 869 | 886 | 903 | 920 | 937 | 954 |
| | Mid-Low Range Vertical | 949 | 970 | 992 | 1013 | 1035 | 1056 | 1078 | 1099 | 1120 | 1142 | 1163 | 1185 | 1206 |
| 20 and 24 (575 Volt) | Mid-High Range Vertical | 941 | 961 | 980 | 1000 | 1019 | 1039 | 1059 | 1078 | 1098 | 1117 | 1137 | 1156 | 1176 |
| | High Range Vertical | 1014 | 1038 | 1061 | 1085 | 1108 | 1132 | 1156 | 1179 | 1203 | 1226 | 1250 | 1273 | 1297 |
| | Low Range Horizontal | 751 | 768 | 785 | 802 | 819 | 836 | 853 | 869 | 886 | 903 | 920 | 937 | 954 |
| | Mid-Low Range Horizontal | 949 | 970 | 992 | 1013 | 1035 | 1056 | 1078 | 1099 | 1120 | 1142 | 1163 | 1185 | 1206 |
| | Mid-High Range Horizontal | 941 | 961 | 980 | 1000 | 1019 | 1039 | 1059 | 1078 | 1098 | 1117 | 1137 | 1156 | 1176 |
| | High Range Horizontal | 1014 | 1038 | 1061 | 1085 | 1108 | 1132 | 1156 | 1179 | 1203 | 1226 | 1250 | 1273 | 1297 |
| | Low Range Vertical | 687 | 703 | 718 | 734 | 749 | 765 | 780 | 796 | 811 | 827 | 842 | 858 | 873 |
| | Mid-Low Range Vertical | 805 | 822 | 839 | 856 | 872 | 889 | 906 | 923 | 940 | 957 | 973 | 990 | 1007 |
| | Mid-High Range Vertical | 941 | 961 | 980 | 1000 | 1019 | 1039 | 1059 | 1078 | 1098 | 1117 | 1137 | 1156 | 1176 |
| | High Range Vertical | 1014 | 1038 | 1061 | 1085 | 1108 | 1132 | 1156 | 1179 | 1203 | 1226 | 1250 | 1273 | 1297 |
| 28 (all voltages) | Low Range Horizontal | 687 | 703 | 718 | 734 | 749 | 765 | 780 | 796 | 811 | 827 | 842 | 858 | 873 |
| | Mid-Low Range Horizontal | 805 | 822 | 839 | 856 | 872 | 889 | 906 | 923 | 940 | 957 | 973 | 990 | 1007 |
| | Mid-High Range Horizontal | 941 | 961 | 980 | 1000 | 1019 | 1039 | 1059 | 1078 | 1098 | 1117 | 1137 | 1156 | 1176 |
| | High Range Horizontal | 1014 | 1038 | 1061 | 1085 | 1108 | 1132 | 1156 | 1179 | 1203 | 1226 | 1250 | 1273 | 1297 |

*Approximate fan rpm shown.
NOTE: Factory pulley speed setting is at 3 turns open.

CONTROLS QUICK START

The following information will provide a quick guide to setting up and configuring the 48/50PG series units with *ComfortLink™* controls. Unit controls are pre-configured at the factory for factory-installed options. Field-installed accessories will require configuration at start-up. Additionally, specific job requirements may require changes to default configuration values. See the CCN and Display parameter tables and other sections of these instructions for more details.

Thermostat Control — Wire accessory thermostat to the corresponding R, Y1, Y2, W1, W2, and G terminals on the field connection terminal board located at the unit control box.

The Unit Control Type configuration, *Configuration* → *UNIT* → *U.CTL*, default value is for Thermostat (2) so there is no need to configure this item.

Space Temperature Sensor Control — Direct Wired (T-55 or T-56) — Wire accessory space temperature sensor(s) to the T-55 terminals on the field connection terminal board located at the unit control box. Refer to Field-Installed Accessories section.

The Unit Control Type configuration, *Configuration* → *UNIT* → *U.CTL*, must be set to Space Sensor (3). The jumper wire in the installer’s packet must be connected between R and W1 for heating mode to operate.

Space Temperature Sensor Control — CCN (T-58) — Install the T-58 communicating thermostat. Connect the CCN communication bus from the T-58 to the CCN terminals on the field connection terminal board located at the unit control box. Configure the 48/50PG unit CCN communication element number, bus number, and baud rate. Configure the T-58 thermostat CCN communication element number and also configure the T-58 with the 48/50PG unit element number.

The Unit Control Type configuration, *Configuration* → *UNIT* → *U.CTL*, must be set to Space Sensor (3). The jumper wire in the installer’s packet must be connected between R and W1 for heating mode to operate.

Space Temperature Control — CCN Linkage — The CCN communication must be properly configured for the 48/50PG unit and all devices. Linkage configuration is automatically done by the supervisory CCN Linkage device.

The Unit Control Type configuration, *Configuration* → *UNIT* → *U.CTL* must be set to Space Sensor (3). The jumper

wire in the installer’s packet must be connected between R and W1 for heating mode to operate.

Installation of an accessory supply air temperature (SAT) sensor in the supply duct is recommended for Linkage applications. A supply duct SAT measurement is valid for heating mode display, while the factory-standard internal SAT is not valid for heating due to its location upstream of the heating section. When installing the supply duct SAT, the heating mode display is enabled by setting *Configuration* → *HEAT* → *SAT.H* to ENBL.

Space Humidity Control — Humidistat — Wire the Humidistat accessory to terminals Humidistat 1 and 2 located on the field connection terminal strip in the bottom of the control box. The Space Humidity Switch setting is located at *Configuration* → *Unit* → *RH.SW*. The factory default for units with Humidi-MiZer™ system is 1 (normally open).

Space Humidity Control — Thermidistat™ — Wire the Thermidistat accessory Dehum output to terminal Humidistat1 located on the field connection terminal strip in the bottom of the control box. The Space Humidity Switch setting is located at *Configuration* → *Unit* → *RH.SW*. The factory default for units with Humidi-MiZer system is 1 (normally open).

Space Humidity Control — Relative Humidity Sensor — Wire the humidity sensor to terminals 3 (–) and 4 (+) located on the field connection terminal strip in the bottom of the control box. The RH Sensor on OAQ Input setting is located at *Configuration* → *Unit* → *RH.S*. The setting must be configured to YES to use the relative humidity sensor.

CCN Communication — Configure *Configuration* → *CCN* → *CCN.A* to desired element number. (Default is 1.) Configure *Configuration* → *CCN* → *CCN.B* to desired bus number. (Default is 0.) Configure *Configuration* → *CCN* → *BAUD* to desired code number for baud rate. (Default is 3 = 9600 baud.)

Accessories — See the Field-Installed Accessories section, control connection tables, and CCN or Display parameter tables for required connections and configurations.

Service Test — The Service Test function can be used to verify proper operation of compressors, heating stages, indoor fan, outdoor fans, power exhaust fans, economizer, Humidi-MiZer system, and alarm relay. Use of Service Test is recommended at initial system start-up and during troubleshooting.

Control Configuration Checklist — Refer to checklist CL-1 for recording site specific unit control configurations.

Programming Operating Schedules — The *ComfortLink™* controls will accommodate up to eight different schedules (Periods 1 through 8), and each schedule is assigned to the desired days of the week. Each schedule includes an occupied on and off time. As an example, to set an occupied schedule for 8 AM to 5 PM for Monday through Friday, the user would set days Monday through Friday to ON for Period 1. Then the user would configure the Period 1 Occupied From point to 08:00 and the Period 1 Occupied To point to 17:00. To create a different weekend schedule, the user would use Period 2 and set days Saturday and Sunday to ON with the desired Occupied On and Off times.

NOTE: By default, the time schedule periods are programmed for 24 hours of occupied operation.

To create a schedule, perform the following procedure:

1. Scroll to the Configuration mode, and select CCN CONFIGURATION (CCN). Scroll down to the Schedule Number (*Configuration* → *CCN* → *SCH.O* = *SCH.N*). If password protection has been enabled, the user will be prompted to enter the password before any new data is accepted. *SCH.N* has a range of 0 to 99. The default value is 1. A value of 0 is always occupied, and the unit will control to its occupied set points. A value of 1 means the unit will follow a local schedule, and a value of 65 to 99 means it will follow a CCN schedule. Schedules 2-64 are not used as the control only supports one internal/local schedule. If one of the 2-64 schedules is configured, then the control will force the number back to 1. Make sure the value is set to 1 to use a local schedule.
2. Enter the Time Clock mode. Scroll down to the LOCAL TIME SCHEDULE (*SCH.L*) sub-mode, and press **ENTER**. Period 1 (*PER.1*) will be displayed.
3. Scroll down to the MON point. This point indicates if schedule 1 applies to Monday. Use the **ENTER** command to go into Edit mode, and use the **▲** or **▼** key to change the display to YES or NO. Scroll down through the rest of the days and apply schedule 1 where desired. The schedule can also be applied to a holiday.
4. Configure the beginning of the occupied time period for Period 1 (OCC). Press **ENTER** to go into Edit mode, and the first two digits of the 00.00 will start flashing. Use the **▲** or **▼** key to display the correct value for hours, in 24-hour (military) time. Press **ENTER** and hour value is saved and the minutes digits will start flashing. Use the same procedure to display and save the desired minutes value.
5. Configure the unoccupied time for period 1 (*UNC*). Press **ENTER** to go into Edit mode, and the first two digits of the 00.00 will start flashing. Use the **▲** or **▼** key to display the correct value for hours, in 24-hour (military) time. Press **ENTER** and hour value is saved and the minutes digits will start flashing. Use the same procedure to display and save the desired minutes value.
6. The first schedule is now complete. If a second schedule is needed, such as for weekends or holidays, scroll down and repeat the entire procedure for period 2 (*PER.2*). If additional schedules are needed, repeat the process for as many as are needed. Eight schedules are provided. See Table 35 for an example of setting the schedule.

SERVICE TEST

The Service Test function can be used to verify proper operation of compressors, heating stages, indoor fan, outdoor fans, power exhaust fans, economizer, and alarm relay. Use of Service Test is recommended at initial system start up and during troubleshooting. See Table 36.

Service Test mode has the following changes from normal operation:

- Normal compressor timeguards and other staging delays are reduced to 30 seconds or less.
- Circuit alerts are limited to 1 strike (versus 3) before changing to alarm shut down state.
- The status of *ALM.N* is ignored so all alerts and alarms are broadcast on CCN.
- The words “SERVICE TEST” are inserted into every alarm message.

Service test can only be turned ON/OFF at the unit display. Once turned ON, other entries may be made with the display or through CCN.

NOTE: Service Test mode may be password protected. Refer to Scrolling Marquee section on page 3 for more information.

To turn Service Test on, change the value of TEST to ON. To turn service test off, change the value of TEST to OFF.

The independent (*INDP*) submenu is used to change output status for the economizer, power exhaust stages, and the alarm relay. These independent outputs can operate simultaneously with other Service Test modes. All outputs return to normal operation when Service Test is turned off. When the economizer is using the factory default Digital Control Type (*Configuration* → *ECON* → *E.CTL* is 1 or 2) then the Economizer Calibration feature may be used to automatically check and reset the economizer actuator range of motion.

The fans (*FANS*) submenu is used to change output status for the indoor fan and outdoor fan stages.

The cooling (*COOL*) submenu is used to change output status for the individual compressors. Compressor starts are staggered by 15 seconds. The fans (*FANS*) and heating (*HEAT*) service test outputs are reset to OFF for the cooling service test. Indoor fans and outdoor fans are controlled normally to maintain proper unit operation. All normal cooling alarms and alerts are functional.

When charging unit, all outdoor fans may be forced on in cooling service test modes by setting the Outdoor Fan Override (*OF.OV*) to on.

NOTE: Circuit A is always operated with Circuit B in Humidi-MiZer™ system equipped units.

For units with the factory Humidi-MiZer option, the Humidi-MiZer (*HZMR*) submenu is used to change the output status to operate the circuits in different Humidi-MiZer modes or to separately test the Humidi-MiZer valve operations. The fans (*FANS*), cooling (*COOL*), and heating (*HEAT*) service test outputs are reset to OFF for the Humidi-MiZer service test. Indoor and outdoor fans are controlled normally to maintain proper unit operation. All normal cooling alarms and alerts are functional.

The heating (*HEAT*) submenu is used to change output status for the individual heat stages, gas or electric. The fans (*FANS*) and cooling (*COOL*) service test outputs are reset to OFF for the heating service test. Indoor and outdoor fans are controlled normally to maintain proper unit operation. All normal heating alarms and alerts are functional.

NOTE: Field terminal strip terminal R must be connected to W1 for the heat to operate in service test. Alert number T410 will occur as a reminder if not done. If the normal unit control mode is thermostat mode, then remove the R-W1 jumper after completing service test.

Table 35 — Setting an Occupied Time Schedule — Weekdays Only for 7:30 to 22:30

| DISPLAY MENU | SUB-SUB MODE | KEYPAD ENTRY | ITEM | DISPLAY | ITEM EXPANSION | COMMENT | |
|-----------------|--------------|--------------|------------------|--------------------------------|--------------------------|--------------------------------|--------------------------------|
| TIMECLOCK SCH.L | | ENTER | | | Local Occupancy Schedule | | |
| | PER.1 | ENTER | OCC.1 | | Period Occupied Time | | |
| | | ENTER | | | 00.00 | | Scrolling stops |
| | | ENTER | | | 00.00 | | Hours Flash |
| | | ▲ | | | 07.00 | | Select 7 |
| | | ENTER | | | 07.00 | | Change accepted, minutes flash |
| | | ▲ | | | 07.30 | | Select 30 |
| | | ENTER | | | 07.30 | | Change accepted |
| | | ESCAPE | OCC.1 | 07.30 | Period Occupied Time | Item/Value/Units scrolls again | |
| | | ▼ | UNC.1 | 00.00 | Period Unoccupied Time | | |
| | | ENTER | | | 00.00 | | Scrolling stops |
| | | ENTER | | | 00.00 | | Hours Flash |
| | | ▲ | | | 22.00 | | Select 22 |
| | | ENTER | | | 22.00 | | Change accepted, minutes flash |
| | | ▲ | | | 22.30 | | Select 30 |
| | | ENTER | | | 22.30 | | Change accepted |
| | | ESCAPE | UNC.1 | 22.30 | Period Unoccupied Time | Item/Value/Units scrolls again | |
| | | ▼ | MON.1 | NO | Monday In Period | | |
| | | ENTER | | | NO | | Scrolling stops |
| | | ▲ | | | YES | | Select YES |
| | | ENTER | | | YES | | Change accepted |
| | | ESCAPE | MON.1 | YES | Monday In Period | Item/Value/Units scrolls again | |
| | | ▼ | TUE.1 | NO | Tuesday In Period | | |
| | | ENTER | | | NO | | Scrolling stops |
| | | ▲ | | | YES | | Select YES |
| | | ENTER | | | YES | | Change accepted |
| | | ESCAPE | TUE.1 | YES | Tuesday In Period | Item/Value/Units scrolls again | |
| | | ▼ | WED.1 | NO | Wednesday In Period | | |
| | | ENTER | | | NO | | Scrolling stops |
| | | ▲ | | | YES | | Select YES |
| | | ENTER | | | YES | | Change accepted |
| | | ESCAPE | WED.1 | YES | Wednesday In Period | Item/Value/Units scrolls again | |
| | | ▼ | THU.1 | NO | Thursday In Period | | |
| | | ENTER | | | NO | | Scrolling stops |
| | | ▲ | | | YES | | Select YES |
| | | ENTER | | | YES | | Change accepted |
| | | ESCAPE | THU.1 | YES | Thursday In Period | Item/Value/Units scrolls again | |
| | | ▼ | FRI.1 | NO | Friday In Period | | |
| | | ENTER | | | NO | | Scrolling stops |
| | | ▲ | | | YES | | Select YES |
| ENTER | | | YES | | Change accepted | | |
| ESCAPE | FRI.1 | YES | Friday In Period | Item/Value/Units scrolls again | | | |
| ESCAPE | | | | | | | |
| ESCAPE | | | | | | | |

Table 36 — Service Test Modes and Submodes Directory

| DISPLAY MENU/ SUB-MENU/NAME | EXPANDED NAME | VALUES | UNITS | DEFAULT | CCN TABLE/ SUB-TABLE | CCN NAME |
|--|--|--|-------|---|-------------------------|--|
| SERVICE TEST TEST | Field Service Test Mode | On/Off | | Off | MAINTENANCE DISPLAY | (TEST = display only) |
| INDP ECON E.CAL PE.1 PE.2 ALRM CCH | Test Independent Outputs Economizer Position Test Calibrate Economizer Power Exhaust 1 Test Power Exhaust 2 Test Alarm Relay Test Crankcase Heat Test | 0 to 100 On/Off On/Off On/Off On/Off On/Off On/Off | % | 0 Off Off Off Off Off | TESTINDP | S_ECONO S_ECOCAL S_PE_1 S_PE_2 S_ALMOUT S_CCH |
| FANS IDF OFC.1 OFC.2 OFC.3 | Test Fans Indoor Fan Test Outdoor Fan 1 Test Outdoor Fan 2 Test Outdoor Fan 3 Test | On/Off On/Off On/Off On/Off | | Off Off Off Off | TESTFANS | S_IDF S_OFC_1 S_OFC_2 S_OFC_3 |
| COOL CMP.A CMP.B CMP.C OF.OV | Test Cooling Cool A Test Cool B Test Cool C Test Outdoor Fan Override | On/Off On/Off On/Off On/Off | | Off Off Off Off | TESTCOOL | S_COMP_A S_COMP_B S_COMP_C S_OFC_OV |
| HMZR RH1.A RH1.B RH1.C RH2.A RH2.B RH2.C CRC RHV.A RHV.B | Test Humidimizer Reheat1 A Test Reheat1 B Test Reheat1 C Test Reheat2 A Test Reheat2 B Test Reheat2 C Test Cool->Reheat1 Valve Test Reheat2 Valve A Test Reheat2 Valve B Test | On/Off On/Off On/Off On/Off On/Off On/Off On/Off On/Off On/Off On/Off | | Off Off Off Off Off Off Off Off Off | TESTHMZR | S_RH1_A S_RH1_B S_RH1_C S2_RH2_A S2_RH2_B S2_RH2_C S_CRC S_RH2_A S_RH2_B |
| HEAT HT.1 HT.2 | Test Heating Heat Stage 1 Test Heat Stage 2 Test | On/Off On/Off | | Off Off | TESTHEAT | S_HEAT_1 S_HEAT_2 |

THIRD PARTY CONTROL

Third party controls may interface with the unit *ComfortLink™* controls through the connections described below. See other sections of these instructions for more information on the related unit control configurations.

Thermostat — The thermostat inputs are provided on the field connection terminal board (TB2). The Thermostat Control Type configuration, *Configuration* → *UNIT* → *T.CTL*, selects the unit response to these inputs.

- Y1 = first stage cooling
- Y2 = second stage cooling
- W1 = first stage heating
- W2 = second stage heating
- G = indoor fan

Humidistat — For units with the factory Humidi-MiZer™ option, the humidistat input is provided on the field connection terminal board (TB2). The Space Humidity Switch configuration, *Configuration* → *UNIT* → *RH.SW*, identifies the normally open or normally closed status of this input at high humidity.

- Humidistat 1 = 24 VAC signal input
- Humidistat 2 = 24 VAC source for dry contact

Humidity Sensor — For units with the factory Humidi-MiZer option and the economizer option with the ECB (economizer control board), the humidity sensor input is provided on the field connection terminal board (TB2). The sensor can be used instead of a humidistat. The RH Sensor on OAQ Input configuration, *Configuration* → *UNIT* → *RH.S=YES*, identifies the sensor use. Default conversion to 0 to 100% relative humidity can be changed in the configurations.

- 4 = 4-20 mA + signal input
- 3 = 4-20 mA – common

Remote Occupancy — The remote occupancy input is provided on the field connection terminal board (TB2). The Remote Occupancy Switch configuration, *Configuration* → *UNIT* → *RM.SW*, identifies the normally open or normally closed status of this input when unoccupied.

- 5 = 24 VAC signal input
- 6 = 24 VAC source for dry contact

Fire Shutdown — The fire shutdown input is provided for unit shutdown in response to a fire alarm or smoke detector. The Fire Shutdown Switch configuration, *Configuration* → *UNIT* → *FS.SW*, identifies the normally open or normally closed status of this input when there is no fire alarm.

For 48/50 units without Humidi-MiZer system, input at field connection terminal board (TB2)

- Fire Shutdown 1 = 24 VAC source for dry contact
- Fire Shutdown 2 = 24 VAC signal input

For 50 series units with Humidi-MiZer system, input at wire harness plug 19 (PL 19)

- PL 19-3 = 24 VAC source for dry contact
- PL 19-5 = 24 VAC signal input for fire shutdown

For 48 series units with Humidi-MiZer system, input at wire harness plug 19 (PL 19)

- PL 19-3 = 24 VAC source for dry contact
- PL 19-5 = 24 VAC signal for Fire Shutdown
- PL 19-4 = 24 VAC power for indoor fan contactor control circuit

NOTE: For 48 series units with Humidi-MiZer system, if the indoor fan must be shut down without any delay upon Fire Shutdown input, then the factory jumper between PL19-3 and PL19-4 must be replaced with a normally closed contact when there is no alarm (open with alarm).

Alarm Output — The alarm output is provided on the field connection terminal board (TB2) to indicate a current alarm status. The output will be 24VAC if a current alarm exists.

- C = 24 VAC common
- X = 24 VAC signal output

Outdoor Enthalpy — For units with the economizer option or accessory and the ECB control board, the outdoor enthalpy input is provided on the field connection terminal board (TB2). The Enthalpy Switch configuration, *Configuration* → *ECON* → *EN.SW*, identifies the normally open or normally closed status of this input when the outdoor enthalpy is low.

- 6 = 24 VAC source for dry contact
- 7 = 24 VAC signal input

IAQ Switch — For units with the economizer option or accessory and the ECB control board, the IAQ switch input is provided on the field connection terminal board (TB2). The IAQ Switch Input configuration, **Configuration**→**AIR.Q**→**I.CF**, identifies the normally open or normally closed status of this input when the indoor air quality value is low (good) and also selects the unit response to this input.

6 = 24 VAC source for dry contact

7 = 24 VAC signal input

NOTE: An IAQ switch cannot be used if an enthalpy switch is already on this input.

IAQ Sensor — For units with the economizer option or accessory and the ECB control board, the IAQ sensor input is provided on the field connection terminal board (TB2). The IAQ Analog Input configuration, **Configuration**→**AIR.Q**→**I.AC** selects the unit response to this input. Default conversion to 0 to 2000 ppm can be changed in the configurations.

2 = 4-20 mA + signal

3 = 4-20 mA – common

OAQ Sensor — For units with the economizer option or accessory and the ECB control board, the OAQ sensor input is provided on the field connection terminal board (TB2). The OAQ Analog Input configuration, **Configuration**→**AIR.Q**→**O.AC** selects the unit response to this input. Default conversion to 0 to 2000 ppm can be changed in the configurations.

3 = 4-20 mA – common

4 = 4-20 mA + signal

NOTE: An OAQ sensor cannot be used if a humidity sensor is used.

CONTROLS OPERATION

Display Configuration — The **Configuration**→**DISP** submenu is used to configure the local display settings.

Metric Display (METR) — This variable is used to change the display from English units to Metric units.

Language Selection (LANG) — This variable is used to change the language of the *ComfortLink* display. At this time, only English is available.

Password Enable (PROT) — This variable enables or disables the use of a password. The password is used to restrict use of the control to change configurations.

Service Password (PSWD) — This variable is the 4-digit numeric password that is required if enabled.

Test Display LEDs (TEST) — This is used to test the operation of the *ComfortLink* display.

Modes — The *ComfortLink* controls operate under a hierarchy of command structure as defined by four main elements: the System Mode, the HVAC Mode, the Occupied status, and the Unit Control Type.

The System Mode is the top level that defines three main states of the control system: Disabled, Enabled, or Test.

The HVAC Mode is the next level that defines four main states of functional operation: Disabled, Fan Only, Cool, and Heat.

The Occupied status affects set points for cooling and heating in Space Sensor control mode and operation of the economizer for indoor air quality ventilation and free cooling.

The Unit Control Type (**Configuration**→**UNIT**→**U.CTL**) defines if temperature control is based on thermostat inputs or space temperature sensor input.

The general operating mode of the control and the status of some related operation lockouts are located on the display at two locations: **Run Status**→**MODE** and **Operating Modes**→**MODE**.

System Mode (SYS) — In Run Status, the current system mode is displayed as a number with expandable text. In

Operating Modes, system mode is displayed as expandable text.

| NUMBER | RUN STATUS EXPANDED TEXT | OPERATING MODES EXPANDED TEXT |
|--------|--------------------------|-------------------------------|
| 1 | Disabled | Unit Operation Disabled |
| 2 | Enabled | Unit Operation Enabled |
| 3 | Test | Service Test Enabled |

HVAC Mode (HVAC) — In Run Status, the current allowed HVAC mode is displayed as a number with expandable text. In Operating Modes, HVAC mode is displayed as expandable text.

| NUMBER | RUN STATUS EXPANDED TEXT | OPERATING MODES EXPANDED TEXT |
|--------|--------------------------|-------------------------------|
| 1 | Disabled | HVAC Operation Disabled |
| 2 | Fan Only | Ventilation (Fan Only) |
| 3 | Cool | Cooling or Free Cooling |
| 4 | Heat | Heating |

NOTE: Optional Humidi-MiZer™ operation is included within Cooling mode.

Currently Occupied (OCC) — Displays the current state of assumed space occupancy based on unit configuration and inputs.

Timed Override in Effect (T.OVR) — Displays if the state of occupancy is currently occupied due to an override.

Linkage Active (LINK) — Displays if a linkage master in a zoning system has established “linkage” with this unit.

Circuit OAT Lockout (C.LOC) — Displays if one or more refrigerant circuits operation is prevented due to outdoor temperature limit lockout.

Heat OAT Lockout (H.LOC) — Displays if heating operation is prevented due to outdoor temperature limit lockout.

Econo Cool OAT Lockout (E.LOC) — Displays if economizer operation for cooling is prevented due to outdoor temperature limit lockout.

Unit Configuration — Many configurations that indicate what factory options and/or field accessories are installed and other common operation variables are included in Unit Configuration (**Configuration**→**UNIT**). Configuration will be done at the factory for any factory-installed option (FIOP).

Start-Up Delay (S.DLY) — This configuration sets the control start-up delay after the power is interrupted. This can be used to stagger the start-up of multiple units.

Unit Control Type (U.CTL) — This configuration defines if temperature control is based on thermostat inputs or space temperature sensor input.

- **U.CTL = 2** (Thermostat) – The unit determines cooling and heating demand by the state of G, Y1, Y2, W1, and W2 inputs from a space thermostat. This value is the factory default.
- **U.CTL = 3** (Space Sensor) – The unit determines cooling and heating demand based on the space temperature and the appropriate set point.

Thermostat Control Type (T.CTL) — This configuration applies only if Unit Control Type is Thermostat (**Configuration**→**Unit**→**U.CTL = 2**). The value determines alternative cooling and Humidi-MiZer circuit staging. See the Cooling and Humidi-MiZer sections for more information. The factory default value is **T.CTL = 0** (Adaptive).

Fan On When Occupied (OC.FN) — This configuration applies only if Unit Control Type is Space Sensor (**Configuration**→**Unit**→**U.CTL = 3**). A YES value will operate the indoor fan whenever the unit is in the Occupied mode. A NO value will operate the indoor fan only when heating or cooling is necessary. The factory default value is YES.

Shut Down on IDF Failure (*ID.FF*) — This configuration applies only if a fan switch is installed and configured. A YES value will enable diagnostic Alert T409 to shut down the unit when incorrect fan status is sensed. A NO value will still permit Alert T409 but will not cause unit shutdown. The factory default value is YES.

Economizer Installed (*EC.EN*) — This configuration identifies if an economizer is installed. A YES value enables economizer operation. A NO value disables economizer operation. This point is repeated in the Economizer Configuration menu (**Configuration** → *ECON* → *EC.EN*).

Fan Status Switch (*FN.SW*) — This configuration identifies if a fan status switch is installed, and what status (normally open, normally closed) the input is when the indoor fan is OFF.

Filter Status Switch (*FL.SW*) — This configuration identifies if a filter status switch is installed, and what status (normally open, normally closed) the input is when the filter is CLEAN.

Fire Shutdown Switch (*FS.SW*) — This configuration identifies if a fire shutdown switch is installed, and what status (normally open, normally closed) the input is when the fire or smoke alarm is OFF (no alarm).

Remote Occupancy Switch (*RM.SW*) — This configuration identifies if a remote occupancy switch is installed, and what status (normally open, normally closed) the input is when UNOCCUPIED.

SAT Settling Time (*SAT.T*) — This configuration sets a supply air temperature settling time before using the reading for compressor staging in some units with multiple circuits. See Adaptive Thermostat Control (*U.CTL = 2*, *T.CTL = 0*) and Space Sensor Control (*U.CTL = 3*) within the Cooling operation section for more information. The factory default value is 240 seconds.

SAT Heat Mode Sensing (*SAT.H*) — This configuration controls the display of the supply-air temperature during heating operation. A DISABLE value will force the displayed supply-air temperature (SAT) to zero when heat is ON and for 5 minutes after. A ENABLE value will display the temperature at all times. See the Heating sections for more information. The factory default is DISABLE due to the factory SAT sensor location. This point is repeated in the Heating Configuration menu.

RAT Sensor On SPTO Input (*RAT.S*) — This configuration identifies if a return air temperature (RAT) sensor is installed on the space temperature offset (SPTO) input. A YES value enables RAT display. A NO value disables RAT display.

RH Sensor On OAQ Input (*RH.S*) — This configuration identifies if a space relative humidity sensor is installed on the outdoor air quality (OAQ) input. A YES value enables *SPRH* display. If a Humdi-MiZer™ unit, then the unit determines dehumidification demand based on this input and the appropriate set point. A NO value disables *SPRH* display and use.

Space Humidity Switch (*RH.SW*) — This configuration identifies if a space relative humidity switch is installed on the ENTHALPY input, and what status (normally open, normally closed) the input is when the space humidity is LOW.

Temperature Compensated Start Cooling Factor (*TCS.C*) — This factor is used in the equation of the Temperature Compensated Start Time Bias for cooling. A setting of 0 minutes indicates Temperature Compensated Start in Cooling is not permitted.

Temperature Compensated Start Heating Factor (*TCS.H*) — This factor is used in the equation of the Temperature Compensated Start Time Bias for heating. A setting of 0 minutes indicates Temperature Compensated Start in Heating is not permitted.

Occupancy Determination — Many factors determine whether the unit considers the building occupied or

unoccupied. If the unit is operating with a space temperature sensor (T-55, T-56 or T-58), occupancy affects the unit set points and the operation of the economizer. If the unit is operating under thermostat control, occupancy only affects the operation of the economizer. The factors affecting occupancy are listed below from highest to lowest priority.

1. The CCN point OCCUPIED is forced via an external device such as a ComfortID™ controller: When OCCUPIED is forced to YES, the unit is considered occupied. When OCCUPIED is forced to NO, the unit is considered unoccupied. If OCCUPIED is not being forced, proceed to the level 2 priority.
2. Remote Occupancy Switch should be configured to either Normally Open or Normally Closed when the user would like to control the occupancy with an external switch. This switch is field-supplied (24-v, single pole, single throw [SPST]). There are three possible configurations for the remote occupancy switch: No Switch (0), Normally Open (1) or Normally Closed (2). This configuration is accessible on the display at **Configuration** → *UNIT* → *RM.SW*. If the switch is configured to No Switch (0), the switch input value will be ignored and software will proceed to the level 3 priority. For each type of switch, the appropriate configuration and states are listed in the table below.

| TYPE OF SWITCH | SWITCH CONFIGURATION | STATE OF SWITCH AND STATE OF OCCUPANCY |
|--|----------------------|--|
| Occupied when closed or Unoccupied when open | Normal Open (1) | Open and Unoccupied |
| | | Closed and Occupied |
| Occupied when open or Unoccupied when closed | Normal Close (2) | Open and Occupied |
| | | Closed and Unoccupied |

NOTE: To perform remote occupancy, an Economizer Control Board must be installed in the unit.

3. The following occupancy options are determined by the state of Occupancy Schedule Number (**Configuration** → *CCN* → *SCH.O* → *SCH.N*) and the Global Schedule Broadcast (**Configuration** → *CCN* → *BROD* → *B.GS*).
 - a. *SCH.N = 0*: The unit is always considered occupied and the programmed schedule is ignored. This is the factory default.
 - b. *SCH.N = 1-64*: Follow the local programmed schedule. Schedules 1 to 64 are local within the controller. The 48/50PG unit can only store one local schedule and therefore changing this number only changes the title of the schedule table.
 - c. *SCH.N = 65-99*: Follow the global programmed schedule. If the 48/50PG unit is configured as a Global Schedule broadcaster (**Configuration** → *CCN* → *BROD* → *B.GS = YES*), the unit will follow the unit's programmed schedule and broadcast the schedule so that other devices programmed to follow this schedule number can receive the schedule. If the 48/50PG unit is not programmed as a Global Schedule broadcaster (**Configuration** → *CCN* → *BROD* → *B.GS = NO*), the unit will receive its information from the unit programmed to broadcast this schedule number.

While using a programmed schedule, occupancy can be temporarily switched from unoccupied to occupied by pressing the override button for approximately 3 seconds on a T-55, T-56, or T-58 device. Override will only occur if **Configuration** → *CCN* → *SCH.O* → *OV.SP* is set to YES. The length of the override period is determined by the setting of **Configuration** → *CCN* → *SCH.O* → *OV.EX*.

Indoor Fan — The indoor fan is controlled by the indoor fan relay output (**Outputs**→**FANS**→**IDF**) on the MBB (main base board) control, which then operates the indoor fan contactor. The indoor fan may operate during cooling with compressors mode, free cooling with outdoor air mode, heating mode, or for ventilation with outdoor air mode.

The indoor fan operation can be affected by configurations for thermostat control type (**Configuration**→**UNIT**→**T.CTL**), the occupancy fan configuration (**Configuration**→**UNIT**→**OC.FN**), the indoor air quality sensor fan configuration (**Configuration**→**AIR.Q**→**IA.FN**), the indoor air quality switch fan configuration (**Configuration**→**AIR.Q**→**II.FN**), and the fan status switch configuration (**Configuration**→**UNIT**→**FN.SW**). For 48PG gas heating units without Humidi-MiZer device, the IGC control fan output is also monitored by the MBB control. This can result in additional modification of fan delays or other operation due to safety functions of the IGC control. See the Indoor Air Quality section if using IAQ (indoor air quality) accessory sensors.

THERMOSTAT CONTROL — In thermostat mode, the IDF relay will be on in the following situations:

- If fan request G in ON, the **IDF** will be ON.
- If cooling request Y1 or Y2 is ON, the **IDF** will be ON.
- If heating request W1 or W2 is ON, the **IDF** will be ON.

SPACE SENSOR CONTROL — In Space Sensor Control mode, the IDF (indoor fan) relay will be on in the following situations. If the unit is in Occupied mode and the indoor fan is configured to always run while occupied (**Configuration**→**UNIT**→**OC.FN**=**YES**), the indoor fan will be ON. If **OC.FN** equals NO or the unit is unoccupied, the indoor fan will operate only when heating or cooling is necessary.

Cooling — Compressors will not operate if the outdoor temperature is less than the value configured for the circuit lockout temperatures (**Configuration**→**COOL**→**CA.LO**; **Configuration**→**COOL**→**CB.LO**; and **Configuration**→**COOL**→**CC.LO**); The Minimum On Time (**Configuration**→**COOL**→**MRT.C**), and Minimum Off Time (**Configuration**→**COOL**→**MOT.C**) time guards apply to all compressors. Factory default values are 3 minutes for Minimum On Time and 5 minutes for Minimum Off Time.

If the indoor fan control is configured to cycle with the cooling demand (**Configuration**→**UNIT**→**OC.FN** = No), the fan will stop after a configured delay (**Configuration**→**COOL**→**FOD.C**). Factory default value is 60 seconds.

THERMOSTAT CONTROL — To operate the unit in Thermostat mode, the Unit Control Type (**Configuration**→**UNIT**→**U.CTL**) configuration must be set to 2 (Thermostat). There are up to four types of thermostat control depending on model size. These are configured with the Thermostat Control Type (**Configuration**→**UNIT**→**T.CTL**).

For economizer equipped units (**Configuration**→**UNIT**→**EC.EN** = Yes), the Adaptive control algorithm is used whenever the economizer can provide cooling. This will

ensure proper time delays and SAT control when the economizer is cooling. Cooling begins when the Y1 input is energized. The economizer will try to provide cooling as described in the Economizer section. If the economizer is not available for cooling or the economizer has been at 100% for 5 minutes, compressor staging will begin.

Configuration→**UNIT**→**T.CTL** = 0 (Adaptive) — When **T.CTL** = 0, additional timers and supply air temperature limits apply to control the compressor staging. In Adaptive mode, a stage of compression will be turned off if the Supply-Air Temperature (**Temperatures**→**AIR.T**→**SAT**) is less than Minimum Supply Air Temperature Lower Level (**Setpoints**→**SAT.L**). In addition, a stage of compression will be turned on if the **SAT** is greater than the Minimum Supply Air Temperature Upper Level (**Setpoints**→**SAT.U**). If **SAT.L** and **SAT.U** are configured so that they are close together, the last stage of compressor might cycle rapidly, slowed only by its minimum on and off-time requirements. Configurable time delays also apply when adding stages (**Configuration**→**COOL**→**C.INC**) or removing stages (**Configuration**→**COOL**→**C.DEC**). **C.INC** and **C.DEC** are accessible via the Scrolling Marquee at **Configuration**→**COOL**. Compressor minimum on-time (**Configuration**→**COOL**→**MRT.C**) and compressor minimum off-time (**Configuration**→**COOL**→**MOT.C**) do apply.

T.CTL = 1 (1 Stage Y1) — When **T.CTL** = 1, no additional compressor staging timers or supply air temperature limits apply. Compressor staging will follow the thermostat inputs directly. Y1 will turn on refrigerant circuit A. Y2 will add refrigerant circuit B. Compressor minimum on-time (**MRT.C**) and compressor minimum off-time (**MOT.C**) do apply.

SPACE SENSOR CONTROL — To operate the unit in Space Sensor mode, set the Unit Control Type to 3 (**Configuration**→**UNIT**→**U.CTL**=3). To enable heating during space temperature control, a jumper wire must be added between R and W1 on the field connection terminal strip (see Major System Components section for wiring diagrams).

Because Space Sensor mode is an “Auto” mode, the control will switch between cooling and heating to maintain space temperature. However, to minimize unnecessary changes, there is a 10-minute mode select timeguard (**Operating Modes**→**COOL**→**MS.TG**), after the last stage of heat turns off before cooling is allowed.

The unit tries to maintain the space temperature at the Occupied Cool Set Point (**Setpoints**→**OCSP**) or the Unoccupied Cool Set Point (**Setpoints**→**UCSP**). See the Occupancy Determination section for factors that affect the Occupied status (**Run Status**→**VIEW**→**OCC**). The Cooling Demand (**Operating Modes**→**COOL**→**SPT**→**DMD.C**) is equal to Space Temperature (**Operating Modes**→**COOL**→**SPT**→**SPT**) minus the occupied or unoccupied set point (**DMD.C** = SPT – set point). See Table 37 for an example of reading and changing the occupied set point (OCSP).

Table 37 — Reading and Changing Cooling Occupied Set Point

| DISPLAY MENU | KEYPAD ENTRY | ITEM | DISPLAY | ITEM EXPANSION | COMMENT |
|--------------|--------------|------|---------|-------------------------|-------------------------------|
| SETPOINTS | ENTER | OCSP | 78 | Occupied Cool Set point | Default: 78 |
| | ENTER | | 78 | | Scrolling Stops |
| | ENTER | | 78 | | Value flashes |
| | ▼ | | | | Select 75 |
| | ENTER | | 75 | | Change accepted |
| | ESCAPE | OCSP | 75 | Occupied Cool Set point | Item/Value/Units scroll again |

Two methods are used to add and remove stages of cooling for units with more than one compressor. The first method causes the unit to operate around its steady-state number of stages. For example, if the correct number of stages is between 0 and 1, this method will cause the first stage to cycle. If the correct number of stages is between 1 and 2, this method will cause the second stage to cycle. The second method causes the unit to find the steady-state number of stages. Details of these methods are provided below.

The control uses two methods to add a stage of compressor cooling. The first method will add a stage of cooling when the Cooling Demand (*Operating Modes*→*COOL*→*SPT*→*DMD.C*) plus the change in cool demand (*Operating Modes*→*COOL*→*SPT*→*TRD.C*) times the Cool Thermal Lag Factor (*Operating Modes*→*COOL*→*SPT*→*C.LAG*) is greater than the SPT Cool Demand (+) Level (*Operating Modes*→*COOL*→*SPT*→*CL.PD*).

$$DMD.C + TRD.C * C.LAG > CL.PD$$

This method is only used after the Compressor Settling Time (*Configuration*→*UNIT*→*SAT.T*), has been exceeded and the supply-air temperature is slowly increasing. The second method will add a stage of cooling when Cool Demand is greater than the SPT Cool Demand (+) Level plus 0.5° F ($DMD.C > CL.PD + 0.5$) and the supply-air temperature (*Operating Modes*→*COOL*→*SAT*→*SAT*) is changing at a rate greater than -0.3° F per minute.

The control uses two methods to remove a stage of compressor cooling. The first method will remove a stage of cooling when the Cooling Demand (*Operating Modes*→*COOL*→*SPT*→*DMD.C*) plus the change in cool demand (*Operating Modes*→*COOL*→*SPT*→*TRD.C*) times the Cool Thermal Lag Factor (*Operating Modes*→*COOL*→*SPT*→*C.LAG*) is less than the SPT Cool Demand (-) Level (*Operating Modes*→*COOL*→*SPT*→*CL.ND*).

$$DMD.C + TRD.C * C.LAG < CL.ND$$

This method is only used after the Compressor Settling Time (*SAT.T*), has been exceeded and the supply air temperature is slowly decreasing. The second method will remove a stage of cooling when Cool Demand is less than the SPT Cool Demand (-) Level minus 0.5° F ($DMD.C < CL.ND - 0.5$) and the supply air temperature (*SAT*) is changing at a rate less than 0.2° F per minute.

Configurable delays also apply when adding stages (*Configuration*→*COOL*→*C.INC*) or removing stages (*Configuration*→*COOL*→*C.DEC*). Compressor minimum on-time (*Configuration*→*COOL*→*MRT.C*) and minimum off-time (*Configuration*→*COOL*→*MOT.C*) also apply.

OUTDOOR FANS — Each unit has a means for variable outdoor airflow to control condenser pressure control within an acceptable range by responding to varied operating modes and ambient temperatures. This is implemented differently on different units using multi-speed motors, multiple outdoor fans, or variable-speed motor controllers.

NOTE: Factory default configurations account for these model differences and should not be changed. The default configurations have been qualified over a large range of conditions and are provided in case a field replacement of a control board occurs and the settings need to be checked or manually configured. Outdoor fan operation is further described below to assist in troubleshooting.

Units Without Humidi-MiZer™ System — The outdoor fan speed, number, and location for each of three levels is defined for each cooling circuit in the Circuit submenus (*Configuration*→*COOL*→*CIR.x*). Results of the factory configurations are shown in Tables 38A-39B. The fan level selected during operation is based on factory configurations of outdoor temperature limits and condenser pressure limits. These are in the Outdoor Fan Control submenu (*Configuration*→*COOL*→*OFC*). Initial fan level starts at zero and increments to

level 1 when Fan LEV0 Max Pressure limit is reached. Changes between levels 1 to 3 are initially selected based on outdoor air temperature (OAT) input and the level On and Off temperature limits. The levels may be further adjusted based on the circuit saturated condensing temperatures (*Temperatures*→*REF.T*→*SCT.x*) and the level Max and Min pressure limits.

Units With Humidi-MiZer System — Outdoor fan control for Humidi-MiZer units includes a Motormaster® variable-speed control for OFM1 and OFM4. Contactor OFC1 controls power to the Motormaster control. The Motormaster control automatically adjusts the outdoor fan speed to maintain approximately 80 to 100 F condenser temperature for circuit A at all outdoor ambient temperatures. Contactor OFC2 controls the remaining two fans (48/50PG20) or remaining 4 fans (48/50PG24 and 28). The fan level operation is determined by some or all outdoor fan control configurations described above, plus additional Humidimizer configurations (*Configuration*→*HZMR*).

Table 38A — Outdoor Fan Level Transitions without Humidi-MiZer System

| FAN LEVEL | OUTDOOR TEMPERATURE (F) |
|-------------|---------------------------------|
| Level 2 On | 55 (size 20), 45 (sizes 24, 28) |
| Level 2 Off | 50 (size 20), 40 (sizes 24, 28) |
| Level 3 On | 65 |
| Level 3 Off | 55 |

Table 38B — Outdoor Fan Level Transitions with Humidi-MiZer System

| FAN LEVEL | OUTDOOR TEMPERATURE (F) |
|-------------|-----------------------------------|
| Level 2 On | 68 (size 20), 61 (size 24 and 28) |
| Level 2 Off | 57 |
| Level 3 On | 88 (size 20), 68 (size 24 and 28) |
| Level 3 Off | 78 (size 20), 62 (size 24 and 28) |

Table 39A — Fan Level Control of Outdoor Fan Contactors (1, 2, 3) without Humidi-MiZer System

| FAN LEVEL | CIRCUIT | |
|-----------|----------------------------|------------------------|
| | A | B |
| 0 | — | — |
| 1 | 1 (20, 24) 1, 3 (28) | 3 |
| 2 | 1, 2 (20) 2 (24, 28) | 2, 3(20) 2 (24, 28) |
| 3 | 1, 2 (20, 24) 1, 2, 3 (28) | 2, 3 |

Table 39B — Fan Level Control of Outdoor Fan Contactors (1 and 2) with Humidi-MiZer System

| FAN LEVEL | CIRCUITS A and B |
|-----------|------------------------|
| 0 | — |
| 1 | 1 |
| 2 | 1, 2 (20) 2 (24-28) |
| 3 | 1, 2 |

Gas Heating (48PG Units) — For 48PG units, the heat type configuration *Configuration*→*HEAT*→*HT.TY* will be factory set to a value of 1.

Heat will not operate if the outdoor temperature is greater than the value configured for the heat lockout temperature, *Configuration*→*HEAT*→*HT.LO*. Minimum on-time, *Configuration*→*HEAT*→*MRT.H*, and minimum off-time, *Configuration*→*HEAT*→*MOT.H*, timeguards apply to both stages of heating. Factory default values are 2 minutes On and 2 minutes Off. The IGC minimum on-time of 1 minute will be followed even if *MRT.H* is lower and during Service Test.

If the indoor fan control is configured to cycle with the heating demand (*Configuration*→*UNIT*→*OC.FN* = *No*) the fan will stop after a configured delay, *Configuration*→*HEAT*→*FOD.G*. Factory default value is 45 seconds. If the IGC temperature limit switch opens within 10 minutes of the end of the gas heating, the next fan off delay will be extended by 15 seconds. The maximum delay is 3 minutes. Once modified by the IGC, the fan off delay will not change back to *FOD.G* unless power is reset to the control.

A light-emitting-diode (LED) is provided on the IGC (integrated gas controller) to indicate its status. During normal operation the LED is continuously on. See the Troubleshooting section if the LED is off or flashing. The IGC is located behind gas section access panel. See Fig. 5 for location.

THERMOSTAT CONTROL — When the thermostat calls for heating, the MBB senses that W1 is On and closes the HT.1 relay. When the relay is closed, it sends power to W on the IGC (integrated gas unit controller) board. An LED (light-emitting diode) on the IGC board will be on during normal operation. A check is made to ensure that the rollout switch and limit switch are closed. The induced-draft motor is then energized. When speed is proven with the Hall Effect sensor on the motor, the ignition activation period begins.

The burners will ignite within 5 seconds. If the burners do not light, there is a 22-second delay before another 5-second attempt. If the burners still do not light, this sequence is repeated for 15 minutes. After the 15 minutes have elapsed, if the burners still have not ignited, heating is locked out. The control will reset when the request for heat is temporarily removed.

When ignition occurs, the IGC board will continue to monitor the condition of the rollout switch, limit switches, Hall Effect sensor, and the flame sensor. If the unit is controlled through a room thermostat set for fan auto, 45 seconds after ignition occurs the indoor-fan motor will be energized (and the outdoor-air dampers will open to their minimum position). If for some reason the overtemperature limit opens prior to the start of the indoor fan blower, on the next attempt, the 45-second delay will be shortened to 5 seconds less than the time from initiation of heat to when the limit tripped. Gas will not be interrupted to the burners and heating will continue. Once modified, the fan on delay will not change back to 45 seconds unless power is reset to the control.

When additional heat is required and the MBB senses that W2 is On, the MBB will turn on the HT.2 relay which sends power to the second stage of the main gas valve. If the thermostat removes the call for W2, the unit will turn off HT.2. If W1

is satisfied, the MBB will turn off HT.1 which will turn off gas to the main burners.

If the user has selected Adaptive (see Cooling section) for its thermostat mode, the algorithm will follow the configurable delays for adding and removing stages. When adding additional heat stages, the delay is measured from when the last stage was added (*Configuration*→*HEAT*→*H.INC*). When removing stages, the delay is measured from when the last stage was removed (*Configuration*→*HEAT*→*H.DEC*). Therefore, if W1 and W2 turn on simultaneously, the second stage will turn on after a *H.INC* delay.

NOTE: If the mode is not Adaptive, then there are no delays for adding and removing stages.

SPACE SENSOR CONTROL — To operate the unit in Space Sensor mode, set the Unit Control Type to 3 (*Configuration*→*UNIT*→*U.CTL*=3). To enable heating during space temperature control, a jumper wire must be added between R and W1 on the field connection terminal strip (see Major System Components section for wiring diagrams).

Because Space Sensor mode is an “Auto” mode, the control will switch between cooling and heating to maintain space temperature. However, to minimize unnecessary changes, there is a 10-minute mode select timeguard (*Operating Modes*→*HEAT*→*MS.TG*) after the last stage of cool turns off before heating is allowed.

The unit tries to maintain the space temperature at the Occupied Heat Set Point (*Setpoints*→*OHSP*) or the Unoccupied Heat Set Point (*Setpoints*→*UHSP*). See the Occupancy Determination section for factors that affect the Occupied status (*Run Status*→*VIEW*→*OCC*). Heating Demand (*Operating Modes*→*HEAT*→*SPT*→*DMD.H*) is equal to the occupied or unoccupied set point minus the Space Temperature (*Operating Modes*→*HEAT*→*SPT*→*SPT*).

$$DMD.H = \text{setpoint} - SPT$$

Two methods are used to add and remove stages of heating for units with more than one heat stage. The first method causes the unit to operate around its steady-state number of stages.

For example, if the correct number of stages is between 0 and 1, this method will cause the first stage to cycle. If the correct number of stages is between 1 and 2, this method will cause the second stage to cycle. The second method causes the unit to find the steady-state number of stages. Details of these methods are provided below.

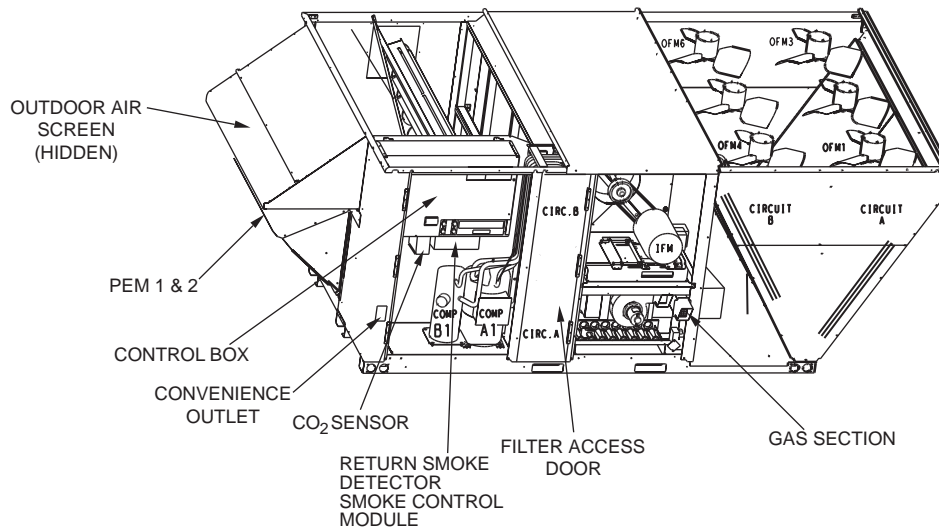

Fig. 5 — Panel and Filter Locations (48PG Unit Shown)

The control uses two methods to add a stage of heating. The first method will add a stage of heating when the Heating Demand (*Operating Modes*→*HEAT*→*SPT*→*DMD.H*) plus the change in heat demand (*Operating Modes*→*HEAT*→*SPT*→*TRD.H*) times the Heat Thermal Lag Factor (*Operating Modes*→*HEAT*→*SPT*→*H.LAG*) is greater than the SPT Heat Demand (+) Level (*Operating Modes*→*HEAT*→*SPT*→*HT.PD*).

$$DMD.H + TRD.H * H.LAG > HT.PD$$

The second method will add a stage of heating when Heat Demand is greater than the SPT Heat Demand (+) Level plus 0.5° F ($DMD.H > HT.PD + 0.5$) and the heat demand is changing at a rate greater than 0.3° F per minute.

The control uses two methods to remove a stage of heating. The first method will remove a stage of heating when the Heating Demand (*Operating Modes*→*HEAT*→*SPT*→*DMD.H*) plus the change in heat demand (*Operating Modes*→*HEAT*→*SPT*→*TRD.H*) times the Heat Thermal Lag Factor (*Operating Modes*→*HEAT*→*SPT*→*H.LAG*) is less than the SPT Heat Demand (-) Level (*Operating Modes*→*HEAT*→*SPT*→*HT.ND*).

$$DMD.H + \text{change } TRD.H * H.LAG < HT.ND$$

The second method will remove a stage of heating when Heat Demand is less than the SPT Heat Demand (-) Level minus 0.5° F ($DMD.H < HT.ND - 0.5$) and the heat demand is changing at a rate less than 0.3° F per minute.

Configurable delays also apply when adding stages (*Configuration*→*HEAT*→*H.INC*) or removing stages (*Configuration*→*HEAT*→*H.DEC*). Heat stage minimum on-time (*Configuration*→*HEAT*→*MRT.H*) and minimum off-time (*Configuration*→*HEAT*→*MOT.H*) also apply.

SUPPLY-AIR TEMPERATURE (SAT) SENSOR — The SAT Heat Sensing Configuration affects the SAT value displayed. The configuration is accessible via the Scrolling Marquee at *Configuration*→*Unit*→*SAT.H*.

Configuration→*HEAT*→*SAT.H* = **DSBL** — When *SAT.H* = **DSBL**, the SAT value on the Scrolling Marquee and CCN tables will be forced to zero when heat outputs come ON and for 5 minutes after. The default SAT sensor location is at the fan inlet, upstream of the heat section.

Configuration→*HEAT*→*SAT.H* = **ENBL** — When *SAT.H* = **ENBL**, the supply-air temperature measured by the SAT sensor is displayed at the scrolling marquee and the CCN tables during heating mode. This setting should only be used if the original SAT sensor is replaced by an accessory SAT sensor located in the supply duct, downstream of the heat section.

Electric Heat (50PG Units) — For 50PG units with factory-installed electric heat, the heat type configuration *Configuration*→*HEAT*→*HT.TY* will be factory set to a value of 2 and the number of heat stages configuration *Configuration*→*HEAT*→*N.HTR* will be factory set to match the installed heater. If electric heat is installed in the field, the value of *HT.TY* must be changed.

Heat will not operate if the outdoor temperature is greater than the value configured for the heat lockout temperature, *Configuration*→*HEAT*→*HT.LO*. Minimum on-time, *Configuration*→*HEAT*→*MRT.H*, and minimum off-time, *Configuration*→*HEAT*→*MOT.H*, timeguards apply to both stages of heating. Factory default values are 2 minutes On and 2 minutes Off.

If the indoor fan control is configured to cycle with the heating demand (*Configuration*→*UNIT*→*OC.FN* = **No**) the fan will stop after a configured delay (*Configuration*→*HEAT*→*FOD.E*). The factory default value is 30 seconds.

THERMOSTAT CONTROL — The first stage of electric heat (HT.1) will follow the W1 input and the second stage (HT.2) of heat will follow the W2 input. During auto fan, the

indoor fan will follow the HT.1 output. During continuous fan, the indoor fan will follow the G input.

If the user has selected Adaptive (see Cooling section) for thermostat mode, the algorithm will follow the configurable delays for adding and removing stages. When adding additional heat stages, the delay is measured from when the last stage was added (*Configuration*→*HEAT*→*H.INC*). When removing stages, the delay is measured from when the last stage was removed (*Configuration*→*HEAT*→*H.DEC*). Therefore, if W1 and W2 turn on simultaneously, the second stage will turn on after a *H.INC* delay.

NOTE: If the mode is not Adaptive, then there are no delays for adding and removing stages.

SPACE SENSOR CONTROL — During Space Sensor control, the electronic control uses information from the space sensor to determine the number of heat stages. Once the number of stages needed for heating is determined, either HT.1 or HT.1 and HT.2 outputs will be turned on. See Space Sensor Control section for gas heat units for more information.

NOTE: The jumper wire in the installer's packer must be connected between R and W1 when using a T-55, T-56, or T-58 device. See Major System Components section.

SUPPLY-AIR TEMPERATURE (SAT) SENSOR — The SAT Heat Sensing Configuration affects the SAT value displayed. SAT Heat Sensing (*SAT.H*) Configuration is accessible via the Scrolling Marquee at *Configuration*→*Unit*→*SAT.H*.

Configuration→*HEAT*→*SAT.H* = **DSBL** — When *SAT.H* = **DSBL**, the SAT value on the Scrolling Marquee and CCN tables will be forced to zero when heat outputs come ON and for 5 minutes after. The default SAT sensor location is at the fan inlet, upstream of the heat section.

Configuration→*HEAT*→*SAT.H* = **ENBL** — When *SAT.H* = **ENBL**, the supply-air temperature measured by the SAT sensor is displayed at the scrolling marquee and the CCN tables during heating mode. This setting should only be used if the original SAT sensor is replaced by an accessory SAT sensor located in the supply duct, downstream of the heat section.

Economizer — If an economizer is installed, then Economizer Installed configuration (*Configuration*→*UNIT*→*EC.EN*) should be set to YES. The economizer is controlled by the economizer output signal (*Outputs*→*ECON*→*EC.CP*) on the ECB control. If the indoor fan is off or the building is unoccupied, the economizer position is zero. If in Occupied mode and the unit is heating or cooling and the economizer cannot provide free cooling, the economizer position is the configured economizer minimum position (*Configuration*→*ECON*→*EC.MN*) or the position specified by the IAQ algorithm. If in Unoccupied mode, the position is 0% open.

The economizer will be allowed to help with cooling if the outdoor-air temperature (*Temperature*→*AIR.T*→*OAT*) is less than the configured economizer high temperature lockout (*Setpoints*→*EH.LO*) and greater than the configured economizer low temperature lockout (*Setpoints*→*EL.LO*). If an enthalpy sensor is installed, the outdoor temperature must be below the economizer high temperature lockout and the enthalpy (*Inputs*→*GEN.I*→*ENTH*) must be LOW. For cooling, the economizer position can vary between the configured economizer minimum position (*Configuration*→*ECON*→*EC.MN*) and the economizer maximum cooling position (*Configuration*→*ECON*→*EC.MX*).

THERMOSTAT CONTROL — If the unit is in cooling, operating under thermostat control, Y1 = ON, and the economizer is available for cooling, the economizer will control the supply-air temperature to the low cool set point (*Setpoints*→*LCSP*). When Y2 = ON, the economizer will control the supply-air temperature to high cool set point (*Setpoints*→*HCSP*).

SPACE SENSOR CONTROL — If the unit is in cooling, operating under space temperature control, the economizer is available for cooling, and no compressors are operating, the economizer will control the SAT to either *Setpoints*→*LCSP* or *Setpoints*→*HCSP* (see Table 40). If a compressor is ON, the economizer will try to position itself at the economizer maximum cooling position (*Configuration*→*ECON*→*EC.MX*).

If the control senses low suction pressure for any active refrigerant circuit when the economizer is also providing cooling, the maximum allowable economizer position will be reduced. Factory default configurations have been qualified over a large range of conditions and should only be changed with care. For unit troubleshooting, factory default maximum economizer limits for this condition are provided in Table 41.

Table 40 — LCSP and HCSP Transitions for Space Temperature Mode

| CURRENT SAT SET POINT | COOL DEMAND (ΔF) | NEXT SAT SET POINT |
|-----------------------|------------------|--------------------|
| LCSP | >0.5 | HCSP |
| HCSP | <0 | LCSP |
| LCSP | <-0.5 | Exit Cooling |

LEGEND

- HCSP — High Cool Set Point
- LCSP — Low Cool Set Point
- SAT — Supply-Air Temperature

Table 41 — Maximum Economizer Limits During Low Suction Pressure

| COOLING STAGE | LIMIT (%) |
|---------------|-----------|
| Bottom | 50 |
| Middle | 50 |
| Top | 0 |

ECONOMIZER ACTUATOR COMMUNICATIONS — The configuration Economizer Control Type determines the communication method, either digital or analog, used to communicate between the ECB and the economizer actuator. Economizer Control Type is accessible via the Scrolling Marquee at *Configurations*→*ECON*→*E.CTL*. The power to the unit must be cycled after *E.CTL* is changed.

E.CTL = 1 (Digital/Position) — When *E.CTL* is set to 1, the ECB will communicate with the economizer actuator using the digital protocol. The ECB 4 to 20 mA output will represent the actuator’s actual position. Because the wiring has a built-in 500-ohm resistor, the 4 to 20 mA signal is converted to a 2 to 10-v signal that is accessible via field connection terminal board TB2-8 and TB2-9. However, before this signal can be read, the violet wire that connects the actuator to field connection terminal board TB2-J10-8 must be removed or cut.

E.CTL = 2 (Digital/Command) — When *E.CTL* is set to 2, the ECB will communicate with the economizer actuator using the digital protocol. The ECB 4 to 20 mA output will represent the actuator’s commanded position. Because the wiring has a built-in 500-ohm resistor, the 4 to 20 mA signal is converted to a 2 to 10-v signal that is accessible via field connection terminal board TB2-8 and TB2-9. However, before this signal can be read, the violet wire that connects the actuator to field connection terminal board TB2-J10-8 must be removed or cut.

E.CTL = 3 (Analog Control) — When *E.CTL* is set to 3, the ECB will communicate with the economizer actuator using the 4 to 20 mA analog signal wired to TB2-8 and TB2-9 along with the 500-ohm resistor producing a 2 to 10-v signal for the actuator. While in this mode, the actuator’s built-in 2 to 10-v feedback signal is accessible via TB2-9 and TB2-10.

UNOCCUPIED FREE COOLING — The unoccupied free cooling algorithm attempts to maintain the building space at the occupied cooling set point during unoccupied periods if the conditions in the building and the outdoors are suitable. Three different configurations define this algorithm: Unoccupied

Free Cooling (*Configuration*→*ECON*→*UEFC*), Free Cooling Preoccupancy Time (*Configuration*→*ECON*→*FC.TM*) and Free Cool Low Temp Limit (*Configuration*→*ECON*→*FC.LO*).

Configuration→*ECON*→*UEFC* = 0 (Disabled) — When *UEFC* = 0, unoccupied free cooling is disabled.

Configuration→*ECON*→*UEFC* = 1 (Unoccupied) — When *UEFC* = 1, unoccupied free cooling can occur whenever the building is unoccupied.

Configuration→*ECON*→*UEFC* = 2 (Preoccupancy) — When *UEFC* = 2, unoccupied free cooling can only occur when the time to the next occupied period is less than *Configuration*→*ECON*→*FC.TM* minutes.

Configuration→*ECON*→*FC.TM* — *FC.TM* is the configuration that determines how many minutes before occupancy that free cooling can occur.

Configuration→*ECON*→*FC.LO* — Unoccupied free cooling cannot occur if the Outdoor Air Temperature (*Temperature*→*AIR.T*→*OAT*) is less than *FC.LO*.

POWER EXHAUST — To enable power exhaust, *Configuration*→*ECON*→*PE.EN* must be set to *ENBL*. If power exhaust is enabled, Power Exhaust 1 will turn on when the economizer position is greater than the value of *Configuration*→*ECON*→*PE.1*. If power exhaust is enabled, Power Exhaust 2 will turn on when the economizer position is greater than the value of *Configuration*→*ECON*→*PE.2*. There are small time delays to ensure that rapid cycling does not occur.

Optional Humidi-MiZer™ Dehumidification System

— Units with the factory-equipped Humidi-MiZer option are capable of providing multiple modes of improved dehumidification as a variation of the normal cooling cycle. The Humidi-MiZer option includes additional valves in the liquid line and discharge line of each refrigerant circuit, a small reheat condenser coil downstream of the evaporator, and Motormaster® variable-speed control of some or all outdoor fans. Operation of the revised refrigerant circuit for each mode is described below.

NOTE: x = refrigerant circuit A or B.

Normal Cooling — Refrigerant flows from the outdoor condenser through the de-energized 3-way valve (RH1.x) to the expansion device. Reheat2 Valve (RH2.x) is closed. See Fig. 6.

Reheat 1 (Subcooling Mode) — This mode increases latent cooling and decreases sensible cooling compared to normal cooling. Refrigerant flows from the outdoor condenser, through the energized 3-way Valve (RH1.x), and through the reheat condenser coil to the expansion device. Reheat2 Valve (RH2.x) is closed. See Fig. 7.

Reheat 2 (Hot Gas Reheat Mode) — This mode provides maximum latent cooling with little to no sensible capacity. This mode can operate to provide dehumidification when there is no cooling demand. Like Reheat 1 mode, refrigerant flows from the outdoor condenser, through the energized 3-way valve (RH1.x), and through the reheat condenser coil to the expansion device. Reheat2 Valve (RH2.x) is open which provides some compressor discharge gas to the reheat condenser to further increase the reheat of the evaporator air stream. See Fig. 8.

Units with multiple circuits can operate with additional staging of the cooling and dehumidification capacity. When there is only cooling demand, based on a space temperature sensor or thermostat, one or more circuits will operate in normal cooling mode. When there is only dehumidification demand, based on a space humidity sensor or switch, all circuits will operate in reheat2 mode. When there is both cooling demand and dehumidification demand, all circuits will operate in either reheat1 or reheat2 mode, with the portion of reheat1 circuits determined from the cooling demand.

Outdoor fan control for Humidi-MiZer system units includes a Motormaster® variable-speed control of some or all outdoor fans, depending on unit model size. The Motormaster control automatically adjusts the outdoor fan speed to maintain approximately 80 to 100 F condenser temperature for circuit A at all outdoor ambient temperatures. Some model sizes have additional on/off staging of some outdoor fans. This staging is controlled by both outdoor temperature and condenser coil temperature.

Compressor staging control for Humidi-MiZer units requires that circuit A always operate when circuit B is on. This applies to normal operation, service test, and for control alarm responses. This operation difference is required due to the fact that the Motormaster outdoor fan control senses circuit A only.

SETTING UP THE SYSTEM — The system requires installation and configuration of either a space relative humidity sensor or a relative humidity switch input.

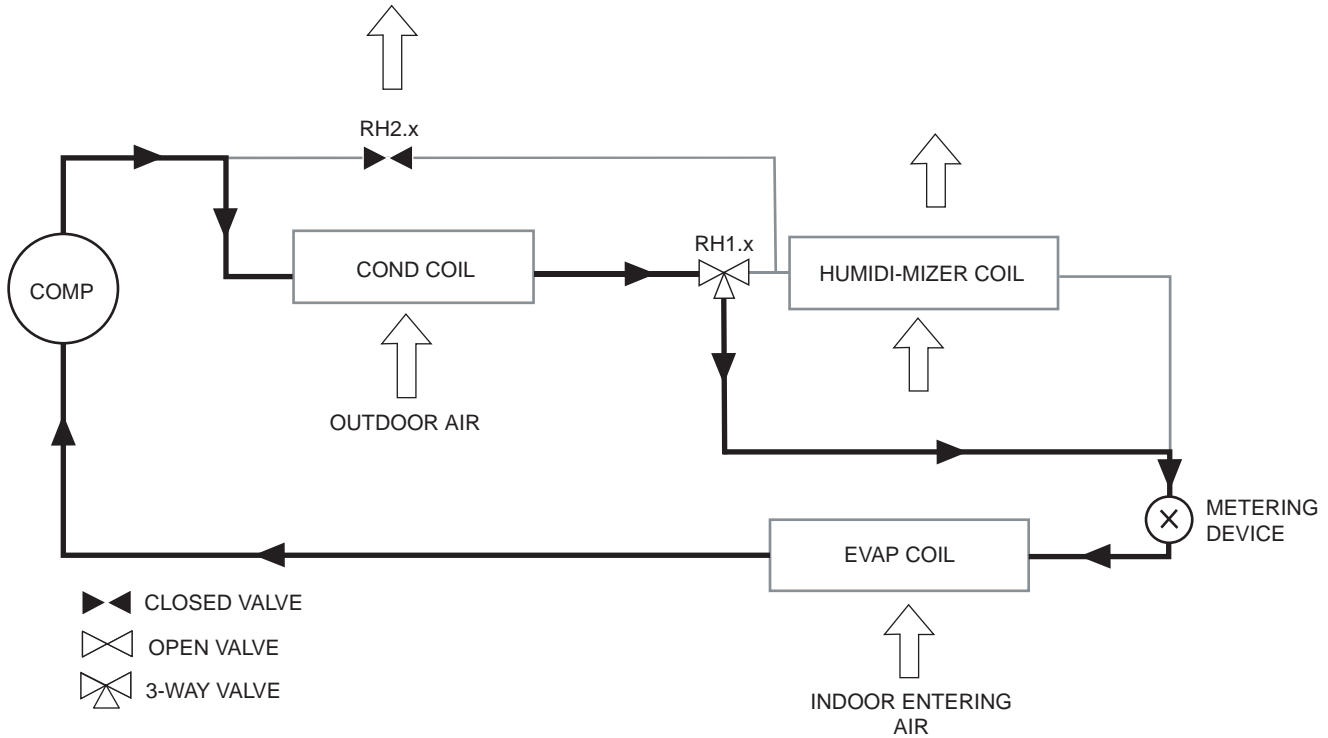

Fig. 6 — Normal Cooling Mode — Humidi-MiZer™ System

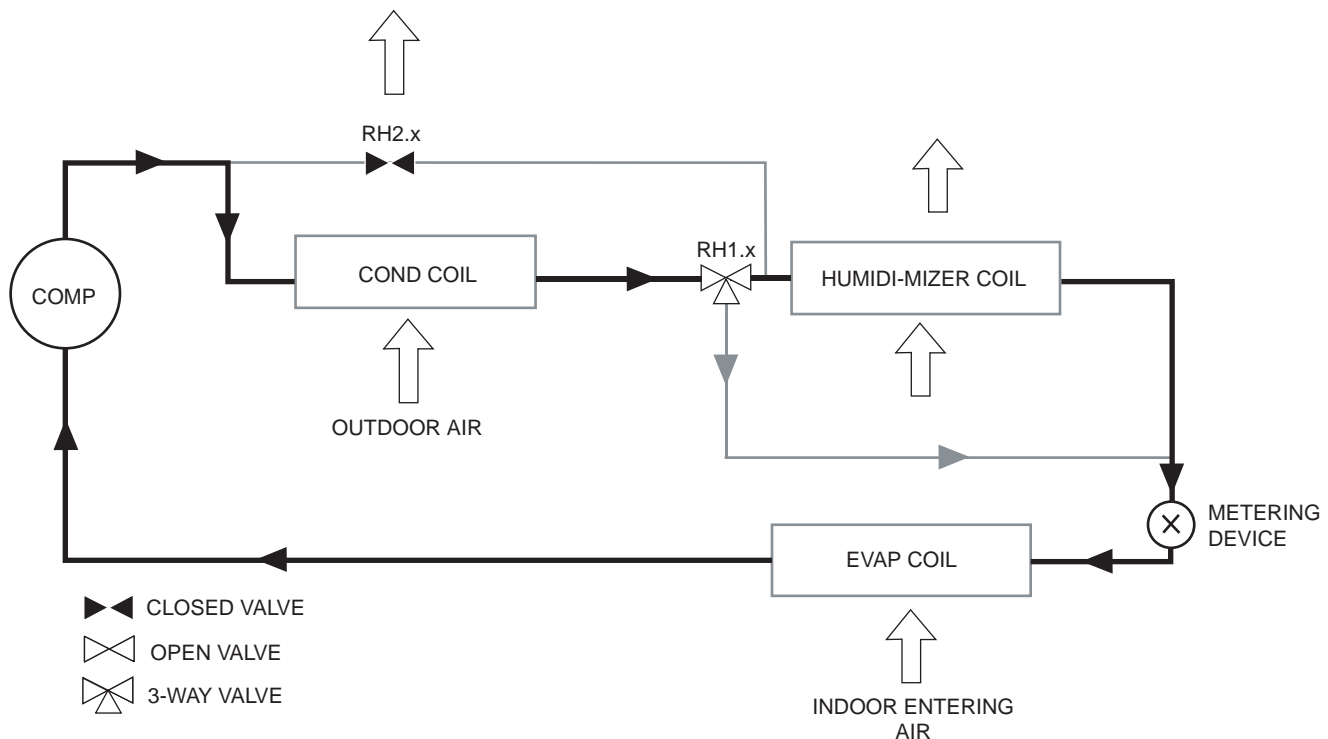

Fig. 7 — Subcooling Mode (Reheat1) — Humidi-MiZer System

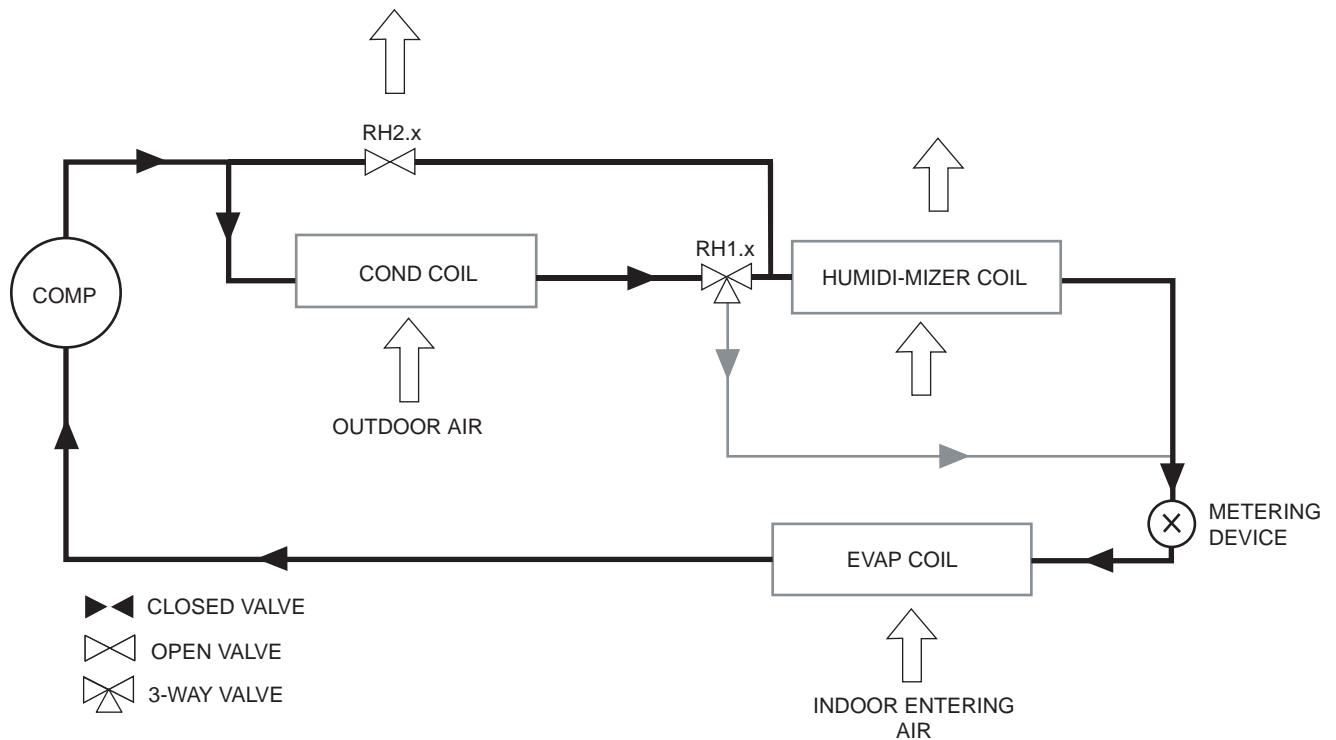

Fig. 8 — Hot Gas Reheat Mode (Reheat2) — Humidi-MiZer™ System

Space Humidity Switch (*Configuration* → *UNIT* → *RH.SW*)

— Set to 1 for use of a normally open switch, or 2 for normally closed switch. The switch is wired to field connection terminal board terminals labeled HUMDISTAT.

RH Sensor on OAQ Input (*Configuration* → *UNIT* → *RH.S*)

— Set to Yes for use of a 4 to 20 mA output RH sensor wired to field connection terminal board terminals 3 and 4. If using an RH sensor, the following configurations also apply:

Space RH Setpoint (*Setpoints* → *RH.SP*) — This sets the target % relative humidity.

Space RH Deadband (*Setpoints* → *RH.DB*) — This sets the control ± deadband for % relative humidity.

RH Sensor Value at 4ma (*Configuration* → *AIR.Q* → *H.4M*)

— This sets the % display for a 4mA input from the relative humidity sensor.

RH Sensor Value at 20ma (*Configuration* → *AIR.Q* → *H.20M*) — This sets the % display for a 20mA input from the relative humidity sensor.

Reheat Heat SP Deadband (*Setpoints* → *RH.HB*) — If the unit is configured for use of a space temperature sensor instead of a thermostat (*Configuration* → *UNIT* → *U.CTL* = Yes), then this configuration applies. This configuration sets the offset above the heating set point at which a unit in Reheat2 mode will turn off. This is a protection against over cooling the space and causing a heat demand.

Other configurations affecting the Humidi-MiZer operation are located at *Configuration* → *HMZR*. See Appendix A.

NOTE: These configurations are dependent on the specific unit and should not be changed. The configurations are provided in case a field replacement of a control board occurs and the settings need to be checked or manually configured.

Humidifier Equipped (*REHT*) — Set to Yes for Humidi-MiZer equipped units. Enables Humidi-MiZer operating modes and service test.

Reheat2 Stage Decr. Time (*R.DEC*) — If using adaptive control mode, then this is a time delay in staged decrease of

multiple circuits in Reheat2 mode. This delay is overridden by a zero demand for dehumidification or a positive demand for cooling.

Reheat2 Stage Incr. Time (*R.INC*) — If using adaptive control mode, then this is a time delay in staged increase of multiple circuits in Reheat2 mode.

Reheat Fan Control (*RH.FN*) — Enables model specific outdoor fan control for certain models equipped with Humidi-MiZer system.

Reheat ODF Fan On Level (*R.FLV*) — Sets the Reheat2 mode outdoor fan level in some model specific fan control.

Reheat2 ODF Fan On Temp (*R.F.ON*) — Sets the Reheat2 mode change temperature to increased outdoor fan level.

Reheat2 ODF Fan Off Temp (*R.F.OF*) — Sets the Reheat2 mode change temperature to decrease outdoor fan level.

Reheat2 OAT Limit A (*RA.LO*) — This configuration is the low outdoor air temperature limit for Reheat2 mode for circuit A. It will disable or enable circuit A.

Reheat2 SSP Lo Limit A (*RA.LP*) — This configuration is the low pressure limit for Reheat2 mode for circuit A. It will turn valve RH2.A off.

Reheat2 SSP Hi Limit A (*RA.HP*) — This configuration is the high pressure limit for Reheat2 mode for circuit A. If low pressure limit previously occurred, this limit will turn valve RH2.A back on after 2-minute delay.

Reheat2 OAT Limit B,C (*RB.LO*) — This configuration is the low outdoor air temperature limit for Reheat2 mode for circuit B. It will disable or enable circuit B.

Reheat2 SSP Lo Limit B,C (*RB.LP*) — This configuration is the low pressure limit for Reheat2 mode for circuit B. It will turn valve RH2.B off.

Reheat2 SSP Hi Limit B,C (*RB.HP*) — This configuration is the high pressure limit for Reheat2 mode for circuit B. If low pressure limit previously occurred, this limit will turn valve RH2.B back on after 2-minute delay.

REHEAT MODE SELECTION PROCESS — Selection of the reheat mode for each refrigerant circuit is determined from the space humidity (from RH sensor or switch input) and the circuit cooling demand (from space temperature sensor or thermostat input). Table 42 shows the corresponding circuit mode and output status for the different demand combinations.

Figure 9 shows the valve locations of Humidi-MiZer™ equipped units. Units with multiple circuits can operate with a combination of Reheat1 and Reheat2 circuits, as determined by the amount of space cooling demand. See Appendix B for complete tables of unit operation response to thermostat and humidity inputs.

REHEAT MODE DIAGNOSTIC HELP — The status of reheat mode sensor inputs may be viewed within the display Inputs menu. The status of reheat mode outputs may be viewed within the display Outputs or *Run Status* → *COOL* menus. Additional diagnostic help, including status of circuit reheat temperature limit lockouts may be viewed within the Humidi-MiZer sub-menu of the cooling mode diagnostic table at *Operating Modes* → *COOL* → *HMZR*.

The Service Test mode may be used to force the system to operate in various stages of Reheat1 or Reheat2 mode, or to independently operate the reheat valve control outputs.

The following forced operating states are changed or added to the available service test operation for a Humidi-MiZer equipped unit:

Service Test → *COOL* → *CMP.A* (Cool A Test) — A value of On will turn on circuit A in Normal Cooling mode.

Service Test → *COOL* → *CMP.B* (Cool B Test) — A value of On will turn on circuits A and B in Normal Cooling mode.

Service Test → *COOL* → *CM.P.C* (Cool C Test) — Not used.

Service Test → *HMZR* → *RH1.A* (Reheat1 A Test) — A value of On will turn on circuit A in Reheat1 mode.

Service Test → *HMZR* → *RH1.B* (Reheat1 B Test) — A value of On will turn on circuits A and B in Reheat1 mode.

Service Test → *HMZR* → *RH1.C* (Reheat1 C Test) — Not used.

Service Test → *HMZR* → *RH2.A* (Reheat2 A Test) — A value of On will turn on circuit A in Reheat2 mode.

Service Test → *HMZR* → *RH2.B* (Reheat2 B,C Test) — A value of On will turn on circuits A and B in Reheat2 mode.

Service Test → *HMZR* → *CRC* (Cool-Reheat1 Valve Test) — A value of On will turn on the CRC relay. This will energize RH1.A and RH1.B.

Service Test → *HMZR* → *RHV.A* (Reheat2 Valve A Test) — A value of On will turn on the RH2.A valve.

Service Test → *HMZR* → *RHV.B* (Reheat2 Valve B,C Test) — A value of On will turn on the RH2.B valve.

Service Test → *Fans* → *OFC.1* (Outdoor Fan 1 Test) — Turn on OFC1, providing power to the Motormaster® controller. Outdoor fans 1 and 4 will operate under the control of the Motormaster controller.

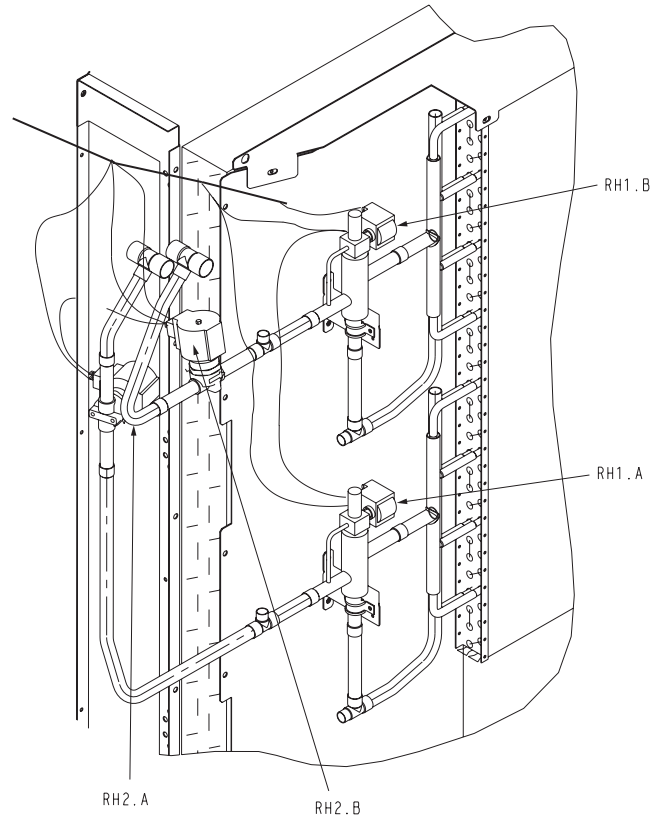

Fig. 9 — Humidi-MiZer System Valve Locations

Service Test → *Fans* → *OFC.2* (Outdoor Fan 2 Test) — Turn on OFC2. Outdoor fans 2, 3, 5, and 6 will operate.

Service Test → *Fans* → *OFC.3* (Outdoor Fan 1 Test) — Not used.

Service Test → *INDP* → *CCH* (Crankcase Heat Test) — Not used. Compressor crankcase heaters are wired directly to line power.

AIR BAFFLES — The 48/50PG units with Humidi-MiZer option are equipped with Motormaster® control to maintain adequate discharge pressure for proper unit operation during low ambient operation. This becomes especially critical in the Reheat2 mode of operation. Wind could have a detrimental effect depending on the orientation and the expected design latent load of the space. If the unit is oriented with the vertical condenser coil toward the prevailing wind, then the field-fabricated wind baffles are required. If the unit is not oriented as described above, but there is expected long operational periods in the Reheat2 mode, then the field-fabricated wind baffles are recommended. See Fig. 10 for dimensions of the field-fabricated wind baffles.

Table 42 — Control Modes with Humidi-MiZer System
Output and Valve States versus Circuit Mode .x = Circuit A or B identifier

| DEMAND AND MODE | | | OUTPUTS | | | | VALVES | |
|-----------------|------------------------|--------------|-------------------------|----------------------------|-------------------------------|-----------------------|-------------------|-------------------|
| Space Humidity | Circuit Cooling Demand | Circuit Mode | Indoor Fan (IDF) | Circuit Compressor (CMP.x) | Cooling-Reheat Control (CRC)* | Reheat2 Valve (RH2.x) | RH1.x Valve 3-way | RH2.x Valve 2-way |
| — | — | No power | OFF | OFF | OFF | OFF | Off | Off (closed) |
| Low | No | Off | Per ventilation control | OFF | OFF | OFF | Off | Off (closed) |
| Low | Yes | Cool | ON | ON | OFF | OFF | Off | Off (closed) |
| High | Yes | Reheat1 | ON | ON | ON | OFF | On | Off (closed) |
| High | No | Reheat2 | ON | ON | ON | ON | On | On (open) |

*NOTE: One CRC state for all circuits per space humidity.

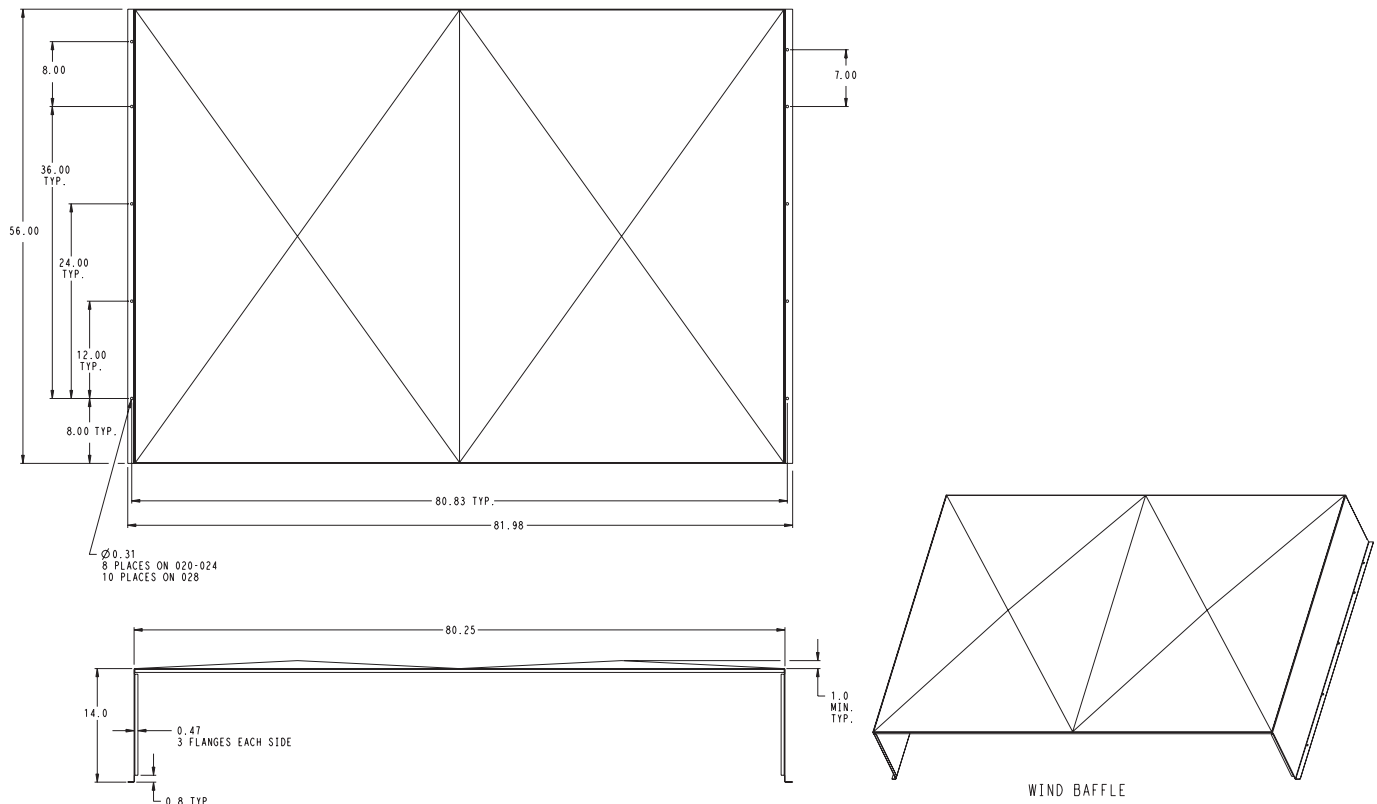

Fig. 10 — Wind Baffle Dimensions

Indoor Air Quality (IAQ) — The *ComfortLink*TM control has the capability for several methods of demand ventilation control. Indoor air quality is typically measured using a CO₂ sensor whose measurements are displayed in parts per million (ppm). Outdoor air quality may be measured with a CO₂ sensor for indoor-outdoor differential demand ventilation control, or with other sensor types for the outdoor air lockout function. The factory-installed indoor air quality CO₂ sensor is mounted in the return section. A field-installed indoor air quality CO₂ sensor may be mounted in the return or directly in the occupied space, per job requirements. The indoor air quality modes of operation can be affected by configurations for indoor air quality sensor (*Configuration* → *AIR.Q* → *IA.CF*), indoor air quality switch (*Configuration* → *AIR.Q* → *II.CF*), outdoor air quality sensor (*Configuration* → *AIR.Q* → *OA.CF*) and other related fan and limit configurations as described below.

IAQ (Analog Input) — The *ComfortLink*TM control is configured for indoor air quality sensors which provide 4 to 20 mA for 0 to 2000 ppm. If a sensor has a different range, the ppm display range must be reconfigured by entering new values for *Configuration* → *AIR.Q* → *I.4M* and *Configuration* → *AIR.Q* → *I.20M*.

IA.CF = 0 (No IAQ) — *IA.CF = 0* signifies that there is no IAQ sensor installed. The damper will operate at the *Configuration* → *AIR.Q* → *EC.MN* position when the space is occupied and the indoor fan is on.

IA.CF = 1 (DCV) — When *IA.CF = 1*, the IAQ algorithm is set for Demand Control Ventilation (DCV). During DCV, the damper modulates between two user configurations depending upon the relationship between the IAQ and the Outdoor Air Quality (OAQ). The lower of these two positions is referred to as the Minimum IAQ Damper Position (*Configuration* → *AIR.Q* → *AQ.MN*) while the higher is referred to as Economizer Minimum Position (*EC.MN*). The *AQ.MN* should be set to an economizer position that brings in enough fresh air to

remove contaminants and CO₂ generated by sources other than people. The *EC.MN* should be set to an economizer position that brings in enough fresh air to remove contaminants and CO₂ generated by all sources including people. The *EC.MN* value is the design value for maximum occupancy.

The *ComfortLink* control will begin to open the damper from the *AQ.MN* position when the IAQ level begins to exceed the Outdoor Air Quality (OAQ) level by a configurable amount. This amount is referred to as AQ Differential Low (*Configuration* → *AIR.Q* → *AQD.L*). When the differential between IAQ and OAQ reaches AQ Differential High (*Configuration* → *AIR.Q* → *AQD.H*), the economizer position will be *EC.MN*. When the IAQ/OAQ differential is between *AQD.L* and *AQD.H*, the control will modulate the damper between *AQ.MN* and *EC.MN* in a linear manner as shown in Fig. 11. The damper position will never exceed the bounds specified by *AQ.MN* and *EC.MN* during IAQ control.

IA.CF = 2 (Override IAQ) — When *IA.CF = 2*, the IAQ algorithm maintains the damper at *Configuration* → *AIR.Q* → *EC.MN* until the override condition triggers. The override triggers when the IAQ/OAQ differential is greater than *Configuration* → *AIR.Q* → *AQD.H*. The override position is *Configuration* → *AIR.Q* → *OVR.P* (Economizer Override Position). The economizer position will return to *EC.MN* when the IAQ/OAQ differential is less than *Configuration* → *AIR.Q* → *AQD.L*.

The Override algorithm will operate whenever the building is occupied and the indoor fan is operating or whenever the IAQ algorithm has caused the indoor fan to operate. The configuration *IA.FN* determines whether or not the IAQ algorithm can turn on the indoor fan.

If the indoor fan is not operating, the economizer position will be zero. If the override is not active and the building is unoccupied, the economizer position will be zero. The damper position may exceed *Configuration* → *AIR.Q*

→*EC.MN* or *Configuration*→*AIR.Q*→*OVR.P* to provide economizer cooling.

***IA.CF = 3* (Control Minimum Position)** — When *IA.CF = 3*, an external 4 to 20 mA source is used to set the minimum position. The 4 mA signal corresponds to 0% and the 20 mA signal corresponds to 100%. In this mode, configurations such as *Configuration*→*AIR.Q*→*EC.MN* and *Configuration*→*AIR.Q*→*AQ.MN* are not used.

If the indoor fan is not operating, the economizer position will be zero. The damper position may exceed the economizer minimum position to provide economizer cooling.

IAQ (Switch Input) — Indoor air quality can also be measured using a switch input. For the purpose of specifying the type of switch input, low CO₂ levels are considered normal. The IAQ switch input is defined by the configuration by *Configuration*→*AIR.Q*→*II.CF* IAQ Level (Switch Input). Enthalpy and IAQ are controlled by the same switch input and therefore they cannot be used simultaneously.

***Configuration*→*AIR.Q*→*II.CF = 0* (No IAQ)** — The *II.CF = 0* configuration signifies that there is no IAQ switch input. The damper will operate at the *EC.MN* position when the space is occupied and the indoor fan is on.

***Configuration*→*AIR.Q*→*II.CF = 1* (DCV NO) or *II.CF = 2* (DCV NC)** — The Demand Control Ventilation (DCV) allows the economizer minimum position to be decreased when there is no IAQ problem. If IAQ is low, the economizer minimum position is Minimum IAQ Damper Position (*Configuration*→*AIR.Q*→*AQ.MN*). If IAQ is high, the economizer minimum position is the Economizer Minimum Position (*Configuration*→*AIR.Q*→*EC.MN*).

***Configuration*→*AIR.Q*→*II.CF = 3* (Override NO) or *II.CF = 4* (Override NC)** — The damper override function permits absolute positioning of the economizer damper for ventilation purposes. The override is active when IAQ is high and inactive when IAQ is low. The override position is configurable by the configuration by *Configuration*→*AIR.Q*→*OVR.P* (Economizer Override Position).

OUTDOOR AIR QUALITY (Analog Input) — The *ComfortLink* control is configured for outdoor air quality sensors which provide 4 to 20 mA for 0 to 2000 ppm. If a sensor has a different range, the ppm display range must be reconfigured by entering new values for *Configuration*→*AIR.Q*→*O.4M* and *Configuration*→*AIR.Q*→*O.20M*.

***Configuration*→*AIR.Q*→*OA.CF = 0* (No OAQ)** — This signifies there is no outdoor air sensor installed. The default value of *OAQ* is 400 ppm.

***Configuration*→*AIR.Q*→*OA.CF = 1* (DCV)** — The outdoor air quality sensor analog input is for the value of *OAQ*.

***Configuration*→*AIR.Q*→*OA.CF = 2* (OAQ Lockout)** — The outdoor air quality sensor analog input is only used to lock out the outdoor ventilation. The economizer commanded position is set to 0% when the ppm exceeds the OAQ lockout value configured for *Configuration*→*AIR.Q*→*OAQ.L*. The default value of *OAQ.L* is 600 ppm.

FAN ENABLE (Analog IAQ Sensor) — The DCV algorithm will operate whenever the building is occupied and the indoor fan is operating or whenever the IAQ algorithm has caused the indoor fan to operate. The configuration *Configuration*→*AIR.Q*→*IA.FN* (Fan Enable for IAQ), determines whether or not the IAQ algorithm can turn on the indoor fan. If the indoor fan is not operating, the economizer position will be zero. The damper position may exceed *Configuration*→*AIR.Q*→*EC.MN* to provide economizer cooling.

***Configuration*→*AIR.Q*→*IA.FN = 0* (Never)** — When *IA.FN = 0*, the IAQ algorithm can never turn on the fan.

***Configuration*→*AIR.Q*→*IA.FN = 1* (Occupied)** — When *IA.FN = 1*, the IAQ algorithm will turn on the indoor fan whenever the building is occupied and IAQ/OAQ differential is greater than the configuration *Configuration*→*AIR.Q*→*DF.ON* (Fan On AQ Differential). The indoor fan will turn off when the IAQ/OAQ differential is less than the configuration *Configuration*→*AIR.Q*→*DF.OF* (Fan Off AQ Differential).

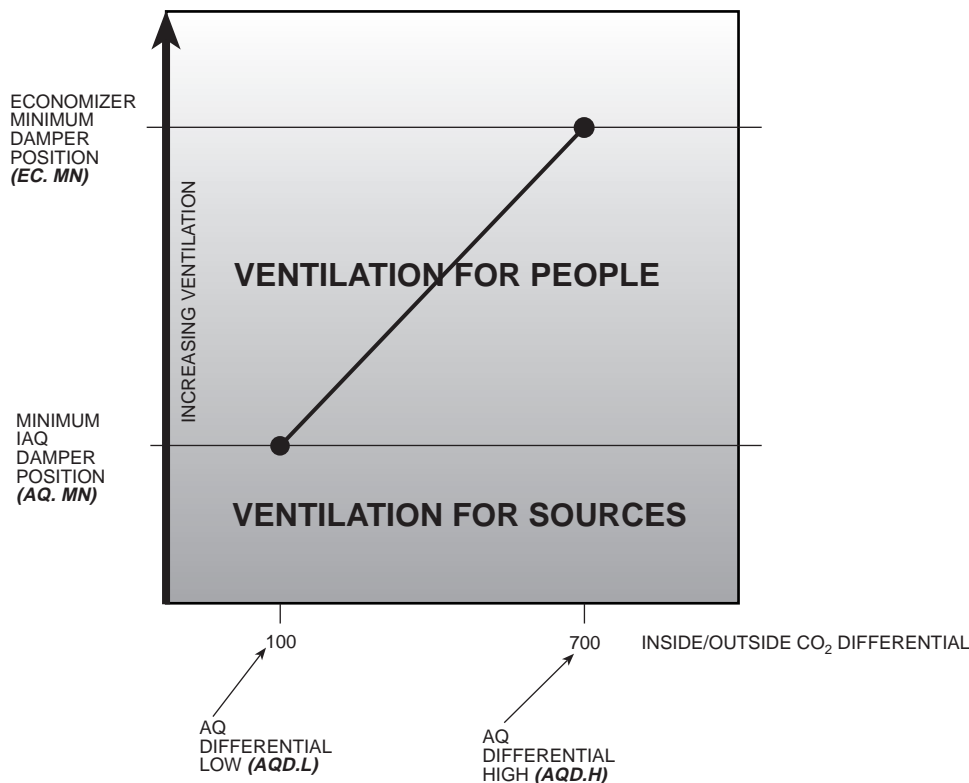

Fig. 11 — IAQ Control

Configuration → AIR.Q → IA.FN = 2 (Always) — The indoor fan performance for *IA.FN = 2* is the same as the performance when *IA.FN = 1* except the algorithm is not limited to occupied periods only. The fan can be triggered on when the space is occupied or unoccupied.

FAN ENABLE (IAQ Switch Input) — The DCV algorithm will operate whenever the building is occupied and the indoor fan is operating or the whenever the IAQ algorithm has caused the indoor fan to operate. The configuration **Configuration → AIR.Q → II.FN** (IAQ Switch Input Fan CFG) determines whether or not the IAQ algorithm can turn on the indoor fan. If the indoor fan is not operating, the economizer position will be zero. The damper position may exceed **Configuration → AIR.Q → EC.MN** to provide economizer cooling.

Configuration → AIR.Q → II.FN = 0 (Never) — When *II.FN = 0*, the IAQ algorithm can never turn on the fan.

Configuration → AIR.Q → II.FN = 1 (Occupied) — When *II.FN = 1*, the IAQ algorithm will turn on the indoor fan whenever the building is occupied and IAQ is high. The indoor fan will turn off if IAQ returns to normal.

Configuration → AIR.Q → II.FN = 2 (Always) — The indoor fan performance for *II.FN = 2* is the same as the performance when *II.FN = 1* except the algorithm is not limited to occupied periods only. The fan can be triggered on when the space is occupied or unoccupied.

Temperature Compensated Start — This logic is used when the unit is in the unoccupied state. The control will calculate early Start Bias time based on Space Temperature deviation from the occupied cooling and heating set points. This will allow the control to start the unit so that the space is at conditioned levels when the occupied period starts. This is required for ASHRAE 90.1 compliance. This control function requires a valid occupancy schedule. A space sensor is required for non-linkage applications.

SETTING UP THE SYSTEM — The settings for temperature compensated start can be found in the local display under **Configuration → UNIT**.

| ITEM | EXPANSION | RANGE | UNITS | CCN POINT |
|--------------|--------------------------|--------|-------|-----------|
| TCS.C | Temp.Cmp.Strt.Cool Factr | 0 - 60 | min | TCSTCOOL |
| TCS.H | Temp.Cmp.Strt.Heat Factr | 0 - 60 | min | TCSTHEAT |

Temp Comp Strt Cool Factr (TCS.C) — This is the factor for the start time bias equation for cooling.

Temp Lamp Strt Heat Factr (TCS.H) — This is the factor for the start time bias equation for heating.

NOTE: Temperature compensated start is disabled when these factors are set to 0.

TEMPERATURE COMPENSATED START LOGIC — The following conditions must be met for the algorithm to run:

- Unit is in unoccupied state.
- Next occupied time is valid.
- Current time of day is valid.
- Valid space temperature reading is available (sensor or CCN network).

The algorithm will calculate a Start Bias time in minutes using the following equations:

If (space temperature > occupied cooling set point)

Start Bias Time = (space temperature – occupied cooling set point)* **TCS.C**

If (space temperature < occupied heating set point)

Start Bias Time = (occupied heating set point – space temperature)* **TCS.H**

When the Start Bias Time is greater than zero the algorithm will subtract it from the next occupied time to calculate the new start time. When the new start time is reached, the Temperature Compensated Start mode is set, the fan is started and the unit controlled as in an occupied state. Once set, Temperature

Compensated mode will stay on until the unit goes into the Occupied mode. The Start Bias Time will be written into the CCN Linkage Equipment Table if the unit is controlled in DAV mode. If the Unoccupied Economizer Free Cool mode is active when temperature compensated start begins, the Unoccupied Free Cool mode will be stopped.

Carrier Comfort Network® (CCN) Configuration — It is possible to configure the *ComfortLink™* control to participate as an element of the Carrier Comfort Network (CCN) system directly from the local display. This section will deal with explaining the various programmable options which are found under the CCN sub-menu in the Configuration mode.

The major configurations for CCN programming are located in the local displays at **Configuration → CCN**. See Appendix A.

CCN Address (CCN.A) — This configuration is the CCN address the rooftop is assigned.

CCN Bus Number (CCN.B) — This configuration is the CCN bus the rooftop is assigned.

CCN Baud Rate (BAUD) — This configuration is the CCN baud rate.

CCN Time/Date Broadcast (BROD → B.TIM) — If this configuration is set to ON, the control will periodically send the time and date out onto the CCN bus once a minute. If this device is on a CCN network then it will be important to make sure that only one device on the bus has this configuration set to ON. If more than one time broadcaster is present, problems with the time will occur.

NOTE: Only the time and date broadcaster can perform daylight savings time adjustments. Even if the rooftop is stand alone, the user may want to set this to ON to accomplish the daylight/savings function.

CCN OAT Broadcast (BROD → B.OAT) — If this configuration is set to ON, the control will periodically broadcast its outside-air temperature at a rate of once every 30 minutes.

Global Schedule Broadcast (BROD → B.GS) — If this configuration is set to ON and the schedule number (*SCH.N*) is between 65 and 99, then the control will broadcast the internal time schedule once every 2 minutes.

CCN Broadcast Acknowledger (BROD → B.ACK) — If this configuration is set to ON, then when any broadcasting is done on the bus, this device will respond to and acknowledge. Only one device per bus can be configured for this option.

Schedule Number (SCH.O → SCH.N) — This configuration determines what schedule the control may follow.

SCH.N = 0 The control is always occupied.

SCH.N = 1 The control follows its internal time schedules. The user may enter any number between 1 and 64 but it will be overwritten to “1” by the control as it only has one internal schedule.

SCH.N = 65-99 The control is either set up to receive to a broadcasted time schedule set to this number or the control is set up to broadcast its internal time schedule (**B.GS**) to the network and this is the global schedule number it is broadcasting. If this is the case, then the control still follows its internal time schedules.

Accept Global Holidays? (SCH.O → HOL.G) — If a device is broadcasting the time on the bus, it is possible to accept the time yet not accept the global holiday from the broadcast message.

Override Time Limit (SCH.O → OV.TL) — This configuration allows the user to decide how long an override occurs when it is initiated. The override may be configured from 1 to 4 hours. If the time is set to 0, the override function will become disabled.

Timed Override Hours (*SCH.O*→*OV.EX*) — This displays the current number of hours left in an override. It is possible to cancel an override in progress by writing “0” to this variable, thereby removing the override time left.

SPT Override Enabled? (*SCH.O*→*OV.SP*) — If a space sensor is present, then it is possible to override an unoccupied period by pushing the override button on the T55 or T56 sensor. This option allows the user to disable this function by setting this configuration to NO.

Alarm Handling — There are a variety of different alerts and alarms in the system. Alerts are indicated by Tnnn (where nnn is the alert number) on the display and generally signify that the improperly functioning circuit can restart without human interaction. If an alarm occurs, indicated by Annn (where nnn is the alarm number), the damaged circuit will generally not restart without an alarm reset via the Scrolling Marquee display or CCN.

The response of the control system to various alerts and alarms depends on the seriousness of the particular alert or alarm. In the mildest case, an alert does not affect the operation of the unit in any manner. An alert can also cause a “strike.” A “striking” alert will cause the circuit to shut down for 15 minutes. This feature reduces the likelihood of false alarms causing a properly working system to be shut down incorrectly. If three strikes occur before the circuit has an opportunity to show that it can function properly, the circuit will be deactivated, causing the shutdown alarm for that particular circuit. Once activated, the shutdown alarm can only be cleared via an alarm reset.

However, circuits with strikes will be given an opportunity to reset their strike counter to zero. As discussed above, a strike typically causes the circuit to shut down. Fifteen minutes later, that circuit will once again be allowed to run. If the circuit is able to run for 1 minute, its replacement circuit will be allowed to shut down (if not required to run to satisfy requested stages). However, the “troubled” circuit must run continuously for a user defined time (*Configuration*→*COOL*→*RST.C*) with no detectable problems before the strike counter will be reset to zero. Default value is 5 minutes.

CCN ALARM BROADCAST — Operators of CCN networks might not want to be notified of “striking” alerts for refrigerant circuits until the circuit has been shut down due to 3 strikes. Set the cooling configuration of Alert Each Strike (*Configuration*→*COOL*→*ALM.N* on display, *ALM_NOW* on CCN) to YES to broadcast each circuit strike alert. Set Alert Each Strike to NO to broadcast only circuit shut down. Alert Each Strike configuration is ignored during Service Test and all alerts are broadcast. The default is YES.

ALARM RELAY OUTPUT — The alarm relay output is a normally open 24 vac output between field connection terminal board terminals C and X. Selection of which alerts and alarms will result in closing of the alarm relay may be set in the Alarm Relay Configuration (*Configuration*→*ALM.O*). Setting a configuration to YES will result in the alarm output relay, *ALRM*, status of ON and 24 vac between C and X when that particular condition is in an alarm state. Setting a configuration to NO will result in no action by the alarm output relay for that particular condition.

NOTE: An accessory filter switch can be used along with the alarm relay output function to indicate dirty filter service need.

See the Troubleshooting section for more information on viewing, diagnosing, and clearing alerts and alarms.

TROUBLESHOOTING

The Scrolling Marquee display shows the actual operating conditions of the unit while it is running. If there are alarms or there have been alarms, they will be displayed in either the current alarm list or the history alarm list. See Table 43. The Service Test mode allows proper operation of the compressors, fans, and other components to be checked while the unit is not operating. See Service Test on page 36.

Complete Unit Stoppage — There are several conditions that can cause the unit not to provide heating or cooling:

- If an alarm is active which causes the unit to shut down, diagnose the problem using the information provided in Alarms and Alerts section below.
- Cooling and heating loads are satisfied.
- Programmed occupancy schedule.
- General power failure.
- Tripped CB1, CB2, or CB3 (24-volt transformer circuit breakers).
- Blown fuse (FU1 or FU2)
- Unit is turned off through the CCN network.
- If supply-air temperature is less than the Minimum SAT Lower Level (*SATL*) configuration value, unit cannot cool.
- If outdoor-air temperature is less than the Compressor Lockout Temperature (*CA.LO*, *CB.LO*, *CC.LO*) configuration value, unit cannot cool.
- If outdoor-air temperature is greater than the Heating Lockout Temperature (*HT.LO*) configuration value, unit cannot heat.

Table 43 — ComfortLink™ Alarm Codes

| ALARM OR ALERT NUMBER | DESCRIPTION | ACTION TAKEN BY CONTROL | RESET METHOD | PROBABLE CAUSE |
|-----------------------|---|---|---|--|
| T051 | Compressor A1 Safety Trip | Add Strike for Circuit A | Automatic | High-pressure switch open. Compressor internal protection open. Wiring error |
| | Compressor A1 Current Detected After Turnoff | Turn off all compressors | Automatic | Welded contactor |
| T052 | Compressor A2 Safety Trip | Add Strike for Circuit A | Automatic | High pressure switch open. Compressor internal protection open. Wiring error. |
| | Compressor A2 Current Detect After Turnoff | Turn off all compressors | Automatic | Welded contactor |
| T055 | Compressor B1 Safety Trip | Add Strike for Circuit B | Automatic | High-pressure switch open. Compressor internal protection open. Wiring error |
| | Compressor B1 Current Detected After Turnoff | Turn off all compressors | Automatic | Welded contactor |
| T059 | Compressor C1 Safety Trip | Add Strike for Circuit C | Automatic | High-pressure switch open. Compressor internal protection open. Wiring error |
| | Compressor C1 Current Detected After Turnoff | Turn off all compressors | Automatic | Welded contactor |
| T064 | Circuit A Saturated Condensing Temp Thermistor Failure | Use OAT to control Outdoor fans | Automatic | Faulty, shorted, or open thermistor caused by wiring error or loose connection. |
| T065 | Circuit B Saturated Condensing Temp Thermistor Failure | Use OAT to control Outdoor fans | Automatic | Faulty, shorted, or open thermistor caused by wiring error or loose connection. |
| T073 | Outdoor Air Temperature Thermistor Failure | No cooling with economizer | Automatic | Faulty, shorted, or open thermistor caused by wiring error or loose connection. |
| T074 | Space Temperature Thermistor Failure | If U.CTL = 3, then no heating or cooling | Automatic | Faulty, shorted, or open thermistor caused by wiring error or loose connection. |
| T075 | Supply Air Temperature Thermistor Failure | No cooling with economizer and No adaptive compressor staging | Automatic | Faulty, shorted, or open thermistor caused by wiring error or loose connection. |
| T076 | Return Air Thermistor Failure | If RAT.S = Yes, then no return air display | Automatic | Faulty, shorted, or open thermistor caused by wiring error or loose connection. |
| T077 | Space Relative Humidity Sensor Failure | If RH.S = Yes, then no indoor humidity control | Automatic | Faulty sensor or wiring error |
| T080 | Circuit C Saturated Condensing Temp Thermistor Failure | Use OAT to control Outdoor fans | Automatic | Faulty, shorted, or open thermistor caused by wiring error or loose connection. |
| T092 | Circuit A Suction Pressure Transducer Failure | Shutdown Circuit A | Manual | Faulty transducer, faulty 5-V power supply, or loose connection |
| T093 | Circuit B Suction Pressure Transducer Failure | Shutdown Circuit B | Manual | Faulty transducer, faulty 5-V power supply, or loose connection |
| T101 | Circuit C Suction Pressure Transducer Failure | Shutdown Circuit C | Manual | Faulty transducer, faulty 5-V power supply, or loose connection |
| T102 | Compressor A1 Current Sensor Failure | If CS.A1 = Enable, then no T051 current alarm | Automatic | Faulty current sensor caused by wiring error or loose connection |
| | Compressor A2 Current Sensor Failure | If CS.A2 = Enable, then no T052 current alarm | Automatic | Faulty current sensor caused by wiring error or loose connection |
| T103 | Compressor B1 Current Sensor Failure | If CS.B1 = Enable, then no T055 current alarm | Automatic | Faulty current sensor caused by wiring error or loose connection |
| T104 | Compressor C1 Current Sensor Failure | If CS.C1 = Enable, then no T059 current alarm | Automatic | Faulty current sensor caused by wiring error or loose connection |
| T110 | Circuit A Loss of Charge | Shutdown Circuit A | Manual | Low refrigerant or faulty suction pressure transducer |
| T111 | Circuit B Loss of Charge | Shutdown Circuit B | Manual | Low refrigerant or faulty suction pressure transducer |
| T126 | Circuit A High Refrigerant Pressure | Shutdown Circuit A | Automatic | An overcharged system, high outdoor ambient temperature coupled with dirty outdoor coil, plugged filter drier, or a faulty high-pressure switch. |
| T127 | Circuit B High Refrigerant Pressure | Shutdown Circuit B | Automatic | An overcharged system, high outdoor ambient temperature coupled with dirty outdoor coil, plugged filter drier, or a faulty high-pressure switch. |
| T133 | Circuit A Low Refrigerant Pressure | Add Strike for Circuit A | Automatic | Low refrigerant charge, dirty filters, evaporator fan turning backwards, loose or broken fan belt, plugged filter drier, faulty transducer, excessively cold return air, or stuck open economizer when the ambient temperature is low. |
| T134 | Circuit B Low Refrigerant Pressure | Add Strike for Circuit B | Automatic | Low refrigerant charge, dirty filters, evaporator fan turning backwards, loose or broken fan belt, plugged filter drier, faulty transducer, excessively cold return air, or stuck open economizer when the ambient temperature is low. |
| T140 | Circuit C Loss of Charge | Shutdown Circuit C | Manual | Low refrigerant or faulty suction pressure transducer |
| T141 | Circuit C Low Refrigerant Pressure | Add Strike for Circuit C | Automatic | Low refrigerant charge, dirty filters, evaporator fan turning backwards, loose or broken fan belt, plugged filter drier, faulty transducer, excessively cold return air, or stuck open economizer when the ambient temperature is low. |
| T142 | Circuit C High Refrigerant Pressure | Shutdown Circuit C | Automatic | An overcharged system, high outdoor ambient temperature coupled with dirty outdoor coil, plugged filter drier, or a faulty high-pressure switch. |
| T143 | Circuit A Failure To Pressurize | Add Strike for Circuit A | Automatic | Wiring causing reverse rotation or faulty compressor |
| T144 | Circuit B Failure To Pressurize | Add Strike for Circuit B | Automatic | Wiring causing reverse rotation or faulty compressor |
| T145 | Circuit C Failure To Pressurize | Add Strike for Circuit C | Automatic | Wiring causing reverse rotation or faulty compressor |
| T153 | Real Timeclock Hardware Failure | No time and date schedule operation | Automatic | No time/date configured, software failure, or MBB failure |
| A154 | Serial EEPROM Hardware Failure | Unit Shutdown | Automatic | Software failure or MBB failure |
| T155 | Serial EEPROM Storage Failure Error | Unit operation errors | Automatic | Software failure or MBB failure |
| A156 | Critical Serial EEPROM Storage Fail Error | Unit Shutdown | Automatic | Software failure or MBB failure |
| A157 | A/D Hardware Failure | Unit Shutdown | Automatic | Software failure or MBB failure |
| A163 | Circuit A Down Due to Failure | Shutdown Circuit A | Manual | Circuit has 3 strikes or has been locked out by another alarm |
| A164 | Circuit B Down Due to Failure | Shutdown Circuit B | Manual | Circuit has 3 strikes or has been locked out by another alarm |
| A165 | Circuit C Down Due to Failure | Shutdown Circuit C | Manual | Circuit has 3 strikes or has been locked out by another alarm |
| T179 | Loss of communication with the Economizer Control Board | No economizer operation | Automatic | Communication wiring problem with ECB or faulty MBB or ECB |
| T180 | Loss of communication with the Economizer Actuator | No economizer operation | Automatic | Communication wiring problem with actuator. |
| A404 | Fire Shutdown | Unit Shutdown | Automatic | Smoke detected by smoke detector |
| T408 | Dirty Filter | — | Automatic | Dirty Filter |
| T409 | Fan Status Switch ON, Contactor OFF | If ID.F.F = Yes, then Unit Shutdown | If ID.F.F = YES, then Manual, otherwise automatic | Bad Fan Status Switch. Configuration incorrect. |
| | Fan Status Switch OFF, Contactor ON | If ID.F.F = Yes, then Unit Shutdown | If ID.F.F = YES, then Manual, otherwise automatic | Tripped Circuit Breaker. Broken belt. Bad indoor fan motor. Configuration incorrect. Bad fan status switch. |

LEGEND

ECB — Economizer Control Board MBB — Main Base Board
 IGC — Integrated Gas Controller OAT — Outdoor-Air Thermistor

Table 43 — ComfortLink™ Alarm Codes (cont)

| ALARM OR ALERT NUMBER | DESCRIPTION | ACTION TAKEN BY CONTROL | RESET METHOD | PROBABLE CAUSE |
|-----------------------|---|----------------------------------|--------------|---|
| T410 | R-W1 Jumper Not Installed in Space Temp Mode | Unable to run heat | Automatic | Missing jumper wire |
| | R-W1 Jumper Must Be Installed to Run Heat In Service Test | Unable to Test Heat Outputs | Automatic | Missing jumper wire. |
| T411 | Thermostat Y2 Input Activated without Y1 Activated | Run unit as if Y2 and Y1 are On | Automatic | Bad Thermostat or Thermostat Wiring |
| T412 | Thermostat W2 Input Activated without W1 Activated | Run unit as if W2 and W1 are On | Automatic | Bad Thermostat or Thermostat Wiring |
| T413 | Thermostat Y and W Inputs Activated Simultaneously | Run unit in mode activated first | Automatic | Bad Thermostat or Thermostat Wiring |
| T414 | Economizer Damper Actuator Out of Calibration | Alert Generated | Automatic | Calibrate economizer (E.CAL). If problem still exist then determine what is limiting economizer rotation. |
| | Economizer Damper Actuator Torque Above Load Limit | Alert Generated | Automatic | Actuator load too high. Check damper load. |
| | Economizer Damper Actuator Hunting Excessively | Alert Generated | Automatic | Damper position changing too quickly. |
| | Economizer Damper Stuck or Jammed | Alert Generated | Automatic | No economizer motion. Check damper blades, gears, and actuator. |
| | Economizer Damper Actuator Mechanical Failure | Alert Generated | Automatic | Check actuator and replace if necessary. |
| | Economizer Damper Actuator Direction Switch Wrong | Alert Generated | Automatic | Actuator direction control switch (CCW, CW) wrong. |
| T415 | IAQ Input Out of Range | No IAQ Operations | Automatic | Bad sensor, bad wiring, or sensor configured incorrectly. |
| T416 | OAQ Input Out of Range | No OAQ Operations | Automatic | Bad sensor, bad wiring, or sensor configured incorrectly. |

LEGEND

ECB — Economizer Control Board MBB — Main Base Board
 IGC — Integrated Gas Controller OAT — Outdoor-Air Thermistor

Restart Procedure — Before attempting to restart the machine, check the alarm list to determine the cause of the shut down. If the shutdown alarm for a particular control function has occurred, determine and correct the cause before allowing the unit to run under its own control again. When there is problem, the unit should be diagnosed in Service Test mode. The alarms must be reset before the control function can operate in either Normal mode or Service Test mode.

Control Module Communication

RED LED — Proper operation of the MBB and ECB control boards can be visually checked by looking at the red status LEDs. When operating correctly, the red status LEDs should blink in unison at a rate of once every 2 seconds. If the red LED on the ECB is not blinking, check the DIP switch positions on the board. If the red LEDs are not blinking in unison, verify that correct power is being supplied to all modules. Also, be sure that the board is supplied with the current software. If necessary, re-load current software. A board LED that is lit continuously or blinking at a rate of once per second or faster indicates that the board should be replaced.

GREEN LED — The MBB and ECB each have one green LED. The Local Equipment Network (LEN) LED should always be blinking whenever power is on. If LEN LED is not blinking, check LEN connections for potential communication errors (J3 and J4 connectors). Communication between modules is accomplished by a 3-wire sensor bus. These 3 wires run in parallel from module to module. The J4 connector on the MBB also provides both power and communication directly to the Scrolling Marquee display.

YELLOW LED — The MBB has one yellow LED which is used to indicate CCN communication activity. The Carrier Comfort Network® (CCN) LED will blink during times of network communication.

Alarms and Alerts

VIEWING AND CLEARING UNIT ALARMS — Presence of active alarms will be indicated on the Scrolling Marquee display by the Alarm Status light turning on and by the number of active alarms being displayed in the automatic View of Run Status. Presence of active alarms may also be signaled on the Alarm Output terminals. Each alarm may also be broadcast on the CCN network. Active alarms and past alarm history can be reviewed and cleared via the local display or a CCN device. The following menu locations are used for the local display:

Alarms → R.CURR (Reset All Current Alarms) — Change to YES to reset all active alarms. Turning unit power off will also reset all current alarms.

Alarms → R.HIST (Reset Alarm History) — Change to YES to reset the alarm history. Turning unit power off will not reset the alarm history.

Alarms → CURR (Currently Active Alarms) — Use the ENTER key, then scroll through any alarm numbers using the up and down arrow keys. Alarms are displayed in numerical order.

Alarms → HIST (Alarm History) — Use the ENTER key, then scroll through any alarm numbers using the up and down arrow keys. Up to 20 alarms are displayed in order of occurrence, with time and date.

The description for an alarm can be viewed on the Scrolling Marquee display by pressing ESCAPE and ENTER keys simultaneously while displaying the alarm code number. Be sure to expand description for each code, because in some cases there are different possible descriptions and causes for the same code number.

DIAGNOSTIC ALARM CODES AND POSSIBLE CAUSES

Alert Codes T051, T052, T055 and T059 (Compressor Safety) — Alert codes T051, T052, T055, and T059 are for compressors A1, A2, B1, and C1, respectively. These alerts occur when the Current Sensor (CS) does not detect compressor current during compressor operation. When this occurs, the control turns off the compressor and logs a strike for the respective circuit. These alerts reset automatically.

The possible causes are:

1. High-pressure switch (HPS) open. The HPS is wired in series with compressor relays on the MBB. If the high-pressure switch opens during compressor operation, the compressor stops, and the CS no longer detects current, causing the control to activate this alert.
2. Compressor internal protection is open.
3. Wiring error. A wiring error might not allow the compressor to start.

To check out alerts T051, T052, T055, and T059:

1. Turn on the compressor in question using Service Test mode. If the compressor does not start, then most likely the problem is one of the following: HPS open, open internal protection, incorrect safety wiring, or incorrect compressor wiring.
2. If the compressor starts, verify that the indoor and outdoor fans are operating properly.
3. If the CS is always detecting current, then verify that the compressor is on. If the compressor is on, check the contactor and the relay on the MBB. If the compressor is off

and there is no current, verify CS wiring and replace if necessary.

4. Return to Normal mode and observe compressor operation to verify that compressor current sensor is working and condenser fans are energized after compressor starts.

Alert Codes T051, T052, T055 and T059 (Current Detected After Turnoff) — Alert codes T051, T052, T055, and T059 are for compressors A1, A2, B1, and C1, respectively. These alerts occur when the Current Sensor (CS) detects current when the compressor should be off. When this occurs, the control turns off all of the compressors. Use the Scrolling Marquee to reset the alert.

The possible causes are

1. Welded contactor.
2. Frozen compressor relay on MBB.

To check out alerts T051, T052, T055, and T059:

1. Place the unit in Service Test mode. All compressors should be Off.
2. Verify that there is not 24 v at the contactor coil. If there is 24 v at the contactor, check relay on MBB and wiring.
3. Check for welded contactor.
4. Verify CS wiring.
5. Return to Normal mode and observe compressor operation to verify that compressor current sensor is working and condenser fans are energized after compressor starts.

Alert Codes T064, T065 and T080 (Condensing Temp. Failure) — Alert codes T064, T065, and T080 are for circuits A, B and C, respectively. These alerts occur when the temperature is outside the range -40 to 240 F (-40 to 116 C). When this occurs, the control will use only the outdoor temperature to control the outdoor fans. If both the SCT and OAT fail, then circuit shutdown alarm will occur also. The cause of the alert is usually a faulty thermistor, a shorted or open thermistor caused by a wiring error, or a loose connection.

Alert Code T073 (Outdoor Air Temp. Failure) — This alert occurs when the temperature is outside the range -40 to 240 F (-40 to 116 C). For all units, all ambient temperature lockout limits for cooling and heating are ignored. For all units, if both SCT and OAT fail, then circuit shutdown alarm will also occur. For economizer equipped units, the economizer will not operate to provide cooling. The economizer will still operate for ventilation. For units without Humidi-MiZer™ system, the control will use condenser temperatures for outdoor fan control. For Humidi-MiZer system equipped units, the Reheat2 mode will operate at fan level 1. For units with CCH crankcase heat relay control, the crankcase heat relay will be turned on if any compressor is off. This alert resets automatically. The cause of the alert is usually a faulty thermistor, a shorted or open thermistor caused by a wiring error, or a loose connection.

Alert Code T074 (Space Temp. Failure) — This alert occurs when the temperature is outside the range -40 to 240 F (-40 to 116 C). This alert will only occur if the unit control type is configured for Space Sensor (versus Thermostat). Cooling and heating will not operate. For economizer equipped units, the economizer will still operate for ventilation. This alert resets automatically. The cause of the alert is usually a faulty thermistor in the T-55, T-56, or T-58 device, a shorted or open thermistor caused by a wiring error, or a loose connection.

Alert Code T075 (Supply Air Temp. Failure) — This alert occurs when the temperature is outside the range -40 to 240 F (-40 to 116 C). Economizer cooling and adaptive compressor staging cannot occur while this alarm is active. This alert resets automatically. The cause of the alert is usually a faulty thermistor, a shorted or open thermistor caused by a wiring error, or a loose connection.

Alert Code T076 (Return Air Thermistor Failure) — This alert occurs when the temperature is outside the range -40 to

240 F (-40 to 116 C). This alert will only occur if the unit is configured for a return air sensor. There is no control action as a result of this alert. This alert resets automatically. The cause of the alert is usually a faulty thermistor, a shorted or open thermistor caused by a wiring error, or a loose connection.

Alert Code T077 (Space Relative Humidity Sensor Failure) — This alert occurs when the input is less than 3.5 mA and the sensor is configured as installed. Check sensor and wiring. This alert clears automatically.

Alert Code T080 (Condensing Temp. Failure) — See Alert T064.

Alert Codes T092, T093, T101 (Suction Pressure Transducer Failure) — Alert codes T092, T093, and T101 are for circuits A, B and C, respectively. These alerts occur when the pressure is outside the range 0.5 to 134.5 psig. A circuit cannot run when this alert is active. Use the Scrolling Marquee to reset the alarm. The cause of the alert is usually a faulty transducer, faulty 5-v power supply, or a loose connection.

Alert Codes T102, T103, and T104 (Current Sensor Failure) — Alert codes T102, T103, and T104 are for compressors A1 and A2, B1, and C1, respectively. These alerts occur when the output of the current sensor (CS) is a constant high value. These alerts reset automatically. The cause of the alert is a wiring error or a loose connection. If the problem cannot be resolved and the CS board must be replaced, the CS board can be temporarily disabled while securing a replaced board. A CS board is disabled by setting the corresponding configuration to DISABLE (**Configuration** → **COOL** → **CIR.A** → **CS.A1**, **CS.B1** or **CS.C1**).

Alert Codes T110, T111, T140 (Loss of Charge) — Alert codes T110, T111, and T140 are for circuits A, B and C, respectively. These alerts occur when the compressor is OFF and the suction pressure is less than 5 psig and OAT is greater than -5 F for 1 continuous minute. Use the Scrolling Marquee to reset the alert. The cause of the alert is usually low refrigerant pressure or a faulty suction pressure. These alerts only occur when the compressor is OFF because the low refrigerant pressure alarms (alerts T133, T134 and T141) handle this situation when the compressor is operating.

Alert Codes T126, T127, T142 (High Refrigerant Pressure) — Alert codes T126, T127, and T142 are for circuits A, B, and C, respectively. These alerts occur when alerts T051, T055, or T059 are active while the appropriate condensing temperature is greater than 150 F. These alerts reset automatically. The cause of the alert is usually an overcharged system, high outdoor ambient temperature coupled with dirty outdoor coil, plugged filter drier, or a faulty high-pressure switch. See Alerts T051, T055 and T059 for diagnostic procedure.

Alert Codes T133, T134, T141 (Low Refrigerant Pressure) — Alert codes T133, T134, and T141 are for circuits A, B and C, respectively. These alerts occur when the compressor is operating and the evaporating temperature (converted from the suction pressure) is less than configured low suction control levels, **Configuration** → **COOL** → **SST** → **SST.1** (Low Suction — Level 1) or **SST.2** (Low Suction — Level 2) or **SST.3** (Low Suction Level 3). The circuit SST value must be less than SST.1 for 5 minutes, SST.2 for 3 minutes, or SST.3 for 1.5 minutes for the alert to occur. When the outdoor temperature is less than 40 F, the above values are reduced by an offset that scales between 0 and 20 as the outdoor temperature goes from 40 to 0° F. An alert will also occur if the circuit SST value is less than **SST.3** -5 F for 20 seconds. These alerts cause a strike for the respective circuit. These alerts will activate when the coil becomes frosted. However, during the 15-minute reset period, the coils will thaw and strike should clear at restart if there is nothing else wrong with the circuit. The alert resets automatically. The cause of the alert is usually low refrigerant charge, dirty filters, evaporator fan operating backwards, loose or broken belt, plugged filter drier, faulty transducer, excessively cold

return air, or stuck open economizer when the ambient temperature is low.

Alert Code T140 (Loss of Charge) — See Alert T110.

Alert Code T141 (Low Refrigerant Pressure) — See Alert T133.

Alert Code T142 (High Refrigerant Pressure) — See Alert T126.

Alert Codes T143, T144, T145 (Failure to Pressurize) — Alert codes T143, T144, and T145 are for circuits A, B, and C, respectively. These alerts occur when the compressor turns on and the suction pressure does not drop 5 psig during the first 15 seconds and the condensing temperature does not rise 5 F during the first minute. These alerts cause a strike for the respective circuit. The alert resets automatically. The cause of the alert is usually compressor wiring causing reverse rotation or a faulty compressor.

Alert Code T153 (Real Time Clock Hardware Failure) — Time and date functions will not operate, such as local occupancy schedules. The RTC clock chip on the MBB is not responding. Recovery is automatic but MBB board replacement may be necessary. Cycling power to the control and reconfiguring the time and date should be tried before board replacement.

Alarm Code A154 (Serial EEPROM Hardware Failure) — The unit will completely shut down. The serial EEPROM chip on the MBB which stores the unit's configuration is not responding. Recovery is automatic but MBB board replacement may be necessary. Cycling the power to the control should be tried before board replacement.

Alert Code T155 (Serial EEPROM Storage Failure Error) — Configuration data in the serial EEPROM chip can not be verified. Recovery is automatic but MBB board replacement may be necessary. Cycling power to the control and reconfiguring the control points should be tried before board replacement.

Alarm Code A156 (Critical Serial EEPROM Storage Fail Error) — The unit will completely shut down. Critical configuration data in the serial EEPROM chip can not be verified. Recovery is automatic but MBB board replacement may be necessary. Cycling power to the control and reconfiguring the critical control points should be tried before board replacement. Check the configurations for the following critical points:

Configuration → **COOL** → **N.CIR** (Number of Circuits)

Configuration → **COOL** → **N.A** (Compressors on Circuit A)

Configuration → **COOL** → **OFC** → **OFC.3** (OFC.3 Enable, CCH Disable)

Configuration → **HMZR** → **REHT** (Humidimizer Equipped)

Configuration → **HMZR** → **RH.FN** (Reheat Fan Control)

Alarm Code A157 (A/D Hardware Failure) — The unit will completely shut down. The analog to digital conversion chip on the MBB has failed. Recovery is automatic but MBB board replacement may be necessary. Cycling power to the control should be tried before board replacement.

Alarm Codes A163, A164, A165 (Circuit Failure) — Alarm codes A163, A164, and A165 are for circuits A, B, and C, respectively. These alarms occur when a circuit has 3 strikes. Use the Scrolling Marquee display to reset the alarm. Investigate the alarm that caused the strikes to occur.

Alert Code T179 (Com. Failure with ECB) — This alert occurs when the MBB cannot communicate with the ECB. This is usually caused by a wiring problem. Investigate using the Low Voltage Schematic.

Alert Code T180 (Com. Failure with Economizer Actuator) — This alert occurs when the MBB cannot communicate with the Belimo Actuator. This is usually caused by a wiring problem. Investigate using the Low Voltage Schematic.

Alarm Code A404 (Fire Shutdown) — This alarm occurs when the shutdown input is either open or closed depending

upon its configuration. This alarm is usually caused by an auxiliary device that is trying to shut down the unit, e.g., smoke detector. The configuration for this switch input can be found at variable **Configuration** → **UNIT** → **FS.SW**. Verify that the configuration is set correct, verify the wiring and auxiliary device. This alarm resets automatically.

Alert Code T408 (Dirty Air Filter) — This alert occurs when the Filter Status switch senses a plugged filter for 120 continuous seconds after the indoor fan has been running for 10 seconds. Because the Dirty Air Filter switch can be configured normally opened or closed, the switch might be open or closed. The configuration for this switch input can be found at variable **Configuration** → **UNIT** → **FL.SW**. Verify that the configuration is set correct, verify the wiring and filter status switch. The hose should be connected to the low side of the switch. This alert resets automatically.

Alert Code T409 (Fan Status Switch On, Fan Contactor Off) — This alarm occurs when the fan status switch has sensed that the indoor fan has been on for 10 seconds and the indoor fan feedback has determined that the indoor fan should be off. Because the Fan Status switch can be configured normally opened or closed, the switch might be open or closed. The configuration for this switch input can be found at **Configuration** → **UNIT** → **FN.SW**. Verify that the configuration is set correctly. Verify the wiring and fan status switch. The hose should be connected to the high side of the switch. If the IDF is configured to shut down the unit when this alarm occurs (**Configuration** → **UNIT** → **IDF.F** = **YES**), then this alarm can only be reset manually and the unit is shut down. If the IDF is not configured to shut the unit down when this alarm occurs (**Configuration** → **UNIT** → **IDF.F** = **NO**), then this alarm resets automatically and no specific control action is taken.

Alert Code T409 (Fan Status Switch Off, Fan Contactor On) — This alert occurs when the fan status switch has sensed that the indoor fan has been off for 10 seconds and the indoor fan feedback has determined that the indoor fan should be on. Because the Fan Status switch can be configured normally opened or closed, the switch might be open or closed. The configuration for this switch input can be found at **Configuration** → **UNIT** → **FN.SW**. Verify that the configuration is set correctly. Verify the wiring and fan status switch. The hose should be connected to the high side of the switch. If the IDF is configured to shut down the unit down when this alert occurs (**Configuration** → **UNIT** → **IDF.F** = **YES**), then this alarm can only be reset manually and the unit is shut down. If the IDF is not configured to shut the unit down when this alert occurs (**Configuration** → **UNIT** → **IDF.F** = **NO**), then this alert resets automatically and no specific control action is taken.

Alert Code T410 (R-W1 Jumper Not Installed in Spare Temp Mode) — This alert occurs when the control mode is Space Temperature mode via Auto Select or Space Temp Select yet there is no power to W1. Verify that space temperature mode is the desired mode or add jumper between R and W1. This alert resets automatically.

Alert Code T410 (R-W1 Jumper Must be Installed to Run Heat in Service Test) — This alert occurs when a request for a heat output has occurred yet the W1 input is not high. A jumper must be installed between R and W1 when trying to test heat in Service Test. The alert will clear when Service Test is exited or if another Service Test mode is selected. Remove jumper when done using Service Test if the unit is operating with a thermostat. The jumper should only be left in place if the unit is operating with a space temperature probe.

Alert Code T411 (Y2 without Y1) — This alert occurs in Thermostat mode when Y2 is energized and Y1 is not. Verify thermostat and thermostat wiring. When Y2 turns On, the software will behave as if Y1 and Y2 are both On. When Y2 turns Off, the software will behave as if Y1 and Y2 are both Off. This alert resets automatically when Y1 is turned On.

Alert Code T412 (W2 without W1) — This alert occurs in Thermostat mode when W2 is energized and W1 is not. Verify thermostat and thermostat wiring. When W2 turns On, the software will behave as if W1 and W2 are both On. When W2 turns Off, the software will behave as if W1 and W2 are both Off. This alert resets automatically when W1 is turned On.

Alert Code T413 (Y and W Simultaneously) — This alert occurs in Thermostat mode when Y1 or Y2 is energized simultaneously with W1 or W2. Verify thermostat and thermostat wiring. The software will enter either the cooling or heating mode depending upon which input turned on first. This alert resets automatically when Y1 and Y2 are not on simultaneously with W1 and W2.

Alert Code T414 (Economizer Damper Actuator Out of Calibration) — This alert occurs when the economizer range of motion is less than 90 degrees. Initiate economizer calibration (*Service Test*→*INDP*→*E.CAL*) using the Service Test menu. The economizer calibration procedure will try to find new maximum open and closed positions. If the alert does not clear automatically after the calibration procedure is complete, investigate what is limiting economizer rotation. This alert resets automatically.

Alert Code T414 (Economizer Damper Actuator Torque Above Load Limit) — This alert occurs when the actuator load is too high. Investigate to determine what is increasing damper load. This alert resets automatically.

Alert Code T414 (Economizer Damper Actuator Hunting Excessively) — This alert occurs when the commanded damper position is changing too rapidly. This alert resets automatically.

Alert Code T414 (Economizer Damper Stuck or Jammed) — This alarm occurs when the actuator senses it can no longer move. Investigate what is stopping the rotation of the actuator and fix. This alert resets automatically.

Alert Code T414 (Economizer Damper Actuator Mechanical Failure) — This alert occurs when the actuator senses a catastrophic failure. Investigate actuator and replace if necessary. This alert resets automatically.

Alert Code T414 (Economizer Damper Actuator Direction Switch Wrong Position) — This alert occurs when the economizer damper direction switch is in the wrong position. The direction switch should be in the clockwise position and the actuator should be mounted so that the CW face of the actuator is accessible. Correct if necessary. This alert clears automatically.

Alert Code T415 (IAQ Input Out of Range) — This alert occurs when the IAQ input is less than 3.5 mA and the sensor is configured as installed. Check sensor and wiring. This alert clears automatically.

Alert Code T416 (OAQ Input Out of Range) — This alert occurs when the OAQ input is less than 3.5 mA and the sensor is configured as installed. Check sensor and wiring. This alert clears automatically.

Cooling Troubleshooting — Use the Scrolling Marquee display or a CCN device to view the cooling status display and the cooling diagnostic display (see Appendix A) for information on the cooling operation. Check the current alarms and alarm history for any cooling alarm codes and correct any causes (see Table 43). Verify any unique control configurations per installed site requirements or accessories. If alarms conditions are

corrected and cleared, operation of the compressors and fans may be verified by using the Service Test mode (see page 36 and Table 36). See Table 44 for general cooling service analysis.

Humidi-MiZer™ Troubleshooting — Use the unit Scrolling Marquee display or a CCN device to view the cooling status display and the cooling diagnostic display (see Appendix A) for information on the cooling operation and the related Humidi-MiZer operation. Check the current alarms and alarm history for any cooling alarm codes and correct any causes (see Table 43). Verify any unique control configurations per installed site requirements or accessories. If alarm conditions are corrected and cleared, operation of the compressors, fans, and Humidi-Mizer valves may be verified by using the Service Test mode (see page 36 and Table 36). In addition to general cooling service analysis Table 44, see Table 45 for general Humidi-MiZer service analysis.

Economizer Troubleshooting — Use the unit Scrolling Marquee display or a CCN device to view the economizer status display and the economizer diagnostic display (see Appendix A) for information on the economizer operation. Check the current alarms and alarm history for any economizer alarm codes and correct any causes (see Table 43). Verify any unique control configurations per installed site requirements or accessories. If alarms conditions are corrected and cleared, operation of the economizer may be verified by using the Service Test mode (see Service Test section on page 36 and Table 36). The following steps specify how to test the economizer using the Scrolling Marquee display. See Table 46 for general economizer service analysis.

1. Enter the *Service Test* main menu on the display.
2. Enter *TEST* and turn ON test mode. A password may be needed in order to turn ON the Service Test. The default password is 1111.
3. Return to the main level of *Service Test*.
4. Enter the *INDP* submenu and enter an initial value for *ECON*. This will drive the economizer damper to the specified position. Continue to adjust the *ECON* value to make sure the economizer opens and closes.
5. Because of a mechanical problem with the economizer, the actuator might acquire a new degree of rotation which is less than 90 degrees. If this occurs, a “T414 Economizer Damper Actuator Out of Calibration” alert will be generated. This alert can only occur if the economizer is using digital communications (*Configuration*→*ECON*→*E.CTL = 1 or 2*). The economizer calibration procedure (*Service Test*→*IND.P*→*E.CAL*) will reconfigure the actuator to the new fully closed and fully open positions. To implement the calibration procedure, change *E.CAL* from OFF to ON. *E.CAL* will remain ON as long as the calibration procedure is being implemented (as long as 5 minutes). During the calibration procedure the actuator will close fully and then open fully. After the calibration is complete, the degree of rotation should be greater than 90 degrees, causing the T414 alert to clear. If the T414 alert does not clear, check the economizer damper for other mechanical problems.
6. Return to *Service Test*→*TEST* and turn OFF test mode. This will cause the unit to return to normal operation.

Table 44 — Cooling Service Analysis

| PROBLEM | CAUSE | REMEDY |
|---|---|---|
| Compressor and Fan Will Not Start. | Power failure. | Call power company. |
| | Fuse blown or circuit breaker tripped. Check CB1, CB2, and CB3. | Replace fuse or reset circuit breaker. |
| | Disconnect off. | Power disconnect. |
| | Compressor time guard to prevent short cycling. | Check using <i>ComfortLink™</i> Scrolling Marquee. |
| | Thermostat or occupancy schedule set point not calling for Cooling. | Check using <i>ComfortLink</i> Scrolling Marquee. |
| | Outdoor temperature too low. | Check Compressor Lockout Temperature using <i>ComfortLink</i> Scrolling Marquee. |
| | Active alarm. | Check active alarms using <i>ComfortLink</i> Scrolling Marquee. |
| Compressor Cycles (other than normally satisfying thermostat). | Insufficient line voltage. | Determine cause and correct. |
| | Active alarm. | Check active alarms using <i>ComfortLink</i> Scrolling Marquee. |
| Compressor Operates Continuously. | Unit undersized for load. | Decrease load or increase size of unit. |
| | Thermostat or occupancy schedule set point too low. | Reset thermostat or schedule set point. |
| | Dirty air filters. | Replace filters. |
| | Low refrigerant charge. | Check pressure, locate leak, repair, evacuate, and recharge. |
| | Condenser coil dirty or restricted. | Clean coil or remove restriction. |
| Excessive Condenser Pressures. | Loose condenser thermistors. | Tighten thermistors. |
| | Dirty condenser coil. | Clean coil. |
| | Refrigerant overcharge. | Recover excess refrigerant. |
| | Faulty TXV. | 1. Check TXV bulb mounting and secure tightly to suction line and insulate. 2. Replace TXV (and filter drier) if stuck open or closed. |
| | Condenser air restricted or air short cycling. | Determine cause and correct. |
| | Restriction in liquid tube. | Remove restriction. |
| | No Power to contactors. | Fuse blown or plug at motor loose. |
| Condenser Fans Not Operating. | High heat load. | Check for sources and eliminate |
| | Faulty TXV. | 1. Check TXV bulb mounting and secure tightly to suction line and insulate. 2. Replace TXV (and filter drier) if stuck open or closed. |
| Excessive Suction Pressure. | Refrigerant overcharged. | Recover excess refrigerant. |
| | Dirty air filters. | Replace air filters. |
| Suction Pressure Too Low. | Low refrigerant charge. | Check pressure, locate leak, repair, evacuate, and recharge. |
| | Faulty TXV. | 1. Check TXV bulb mounting and secure tightly to suction line and insulate. 2. Replace TXV (and filter drier) if stuck open or closed. |
| | Insufficient evaporator airflow. | Check belt tension. Check for other restrictions. |
| | Temperature too low in conditioned area (low return-air temperature). | Reset thermostat or occupancy schedule. |

LEGEND

- CB** — Circuit Breaker
- TXV** — Thermostatic Expansion Valve

Table 45 — Humidi-MiZer™ Service Analysis

| PROBLEM | CAUSE | REMEDY |
|---|--|---|
| Subcooling Reheat Mode Will Not Activate. | General cooling mode problem. | See Cooling Service Analysis (Table 44). |
| | No dehumidification demand. | See No Dehumidification Demand, below. |
| | Circuit RH1 valve is not open. | See RH1 Valve Operation, below. |
| Hot Gas Reheat Mode Will Not Activate. | General cooling mode problem. | See Cooling Service Analysis (Table 44). |
| | No dehumidification demand. | See No Dehumidification Demand, below. |
| | Circuit RH1 valve is not open. | See RH1 Valve Operation, below. |
| | Circuit RH2 valve is not open. | See RH2 Valve Operation, below. |
| | Outdoor temperature too low. | Check Reheat2 Circuit Limit Temperatures (Configuration→HMZR→RA.LO and RB.LO) using <i>ComfortLink™</i> Scrolling Marquee. |
| No Dehumidification Demand. | Relative humidity setpoint is too low — Humidistat | Check/reduce setting on accessory humidistat. |
| | Relative humidity setpoint is too low — RH sensor. | Check Space RH Setpoint (Setpoints→RH.SP) using <i>ComfortLink</i> Scrolling Marquee. |
| | Software configuration error for accessory humidistat. | Check Space Humidity Switch (Configuration→UNIT→RH.SW) using <i>ComfortLink</i> Scrolling Marquee. |
| | Software configuration error for accessory humidity sensor. | Check RH Sensor on OAQ Input (Configuration→UNIT→RH.S) using <i>ComfortLink</i> Scrolling Marquee. |
| | No humidity signal. | Check wiring. Check humidistat or humidity sensor. |
| RH1 Valve Operation. | No 24V signal to input terminals. | Check using Cool→Reheat1 Valve Test (Service Test→HMZR→CRC) using <i>ComfortLink</i> Scrolling Marquee. Check Wiring. Check transformer and circuit breaker or fuses. |
| | Solenoid coil burnout. | Check continuous over-voltage is less than 10%. Check under-voltage is less than 15%. Check for missing coil assembly parts. Check for damaged valve enclosing tube. |
| | Stuck valve. | Replace valve. Replace filter drier. |
| | | |
| | | |
| RH2 Valve Operation. (NOTE: Normally Closed When Deenergized) | No 24V signal to input terminals. | Check using Cool→Reheat1 Valve Test (Service Test→HMZR→RHV.A or RHV.B) using <i>ComfortLink</i> Scrolling Marquee. Check MBB relay output. Check wiring. Check transformer and circuit breaker or fuses. |
| | Solenoid coil burnout. | Check continuous over-voltage is less than 10%. Check under-voltage is less than 15%. Check for missing coil assembly parts. Check for damaged valve enclosing tube. |
| | Stuck valve. | Replace valve. Replace filter drier. |
| | | |
| | | |
| Low Latent Capacity in Subcooling or Hot Gas Reheat Modes. | RH1 valve open or leaking. | See RH1 Valve Operation, above. |
| Low Sensible Capacity in Normal Cool or Subcooling Reheat Modes. | RH2 valve open or leaking. | See RH2 Valve Operation, above. |
| Low Suction Pressure and High Superheat During Normal Cool Mode. | General cooling mode problem. | See Cooling Service Analysis (Table 44). |
| | RH2 valve open or leaking. | See RH2 Valve Operation, above. |
| Low Suction Pressure | General cooling mode problem. | See Cooling Service Analysis (Table 44). |
| RH2 Valve Cycling On/Off. | Hot Gas Reheat mode low suction pressure limit. | Normal Operation During Mixed Circuit Subcooling and Hot Gas Reheat Modes at Lower Outdoor Temperatures. |
| Circuit B Will Not Operate With Circuit A Off. | Normal operation. Motormaster outdoor fan control requires operation of circuit A. | None |

LEGEND

- CV — Cooling Valve
- RH — Relative Humidity

Table 46 — Economizer Service Analysis

| PROBLEM | POSSIBLE CAUSE | REMEDY |
|---|---|---|
| Damper Does Not Move. | Indoor Fan is off. | Check for proper thermostat connection. |
| | | Unit is not configured for continuous fan operation and the thermostat is not calling for heating or cooling. |
| | | Unit is in Unoccupied mode and there is no call for heating or cooling. |
| | | Tripped circuit breaker. |
| | | No power to the unit. |
| | Unit is off via CCN command. | |
| | Actuator is unplugged at motor or at economizer board. | Check wiring connections. |
| | Unit is not configured for economizer. | Configure unit for economizer per the instructions. |
| Economizer Operation is Limited to Minimum Position. | Outdoor-air temperature is above economizer high temperature lockout. | Adjust the high temperature lockout setting if it is incorrect, otherwise, economizer is operating correctly. |
| | Outdoor-air temperature is below economizer low temperature lockout. | Adjust the low temperature lockout setting if it is incorrect, otherwise, economizer is operating correctly. |
| | Communication loss to economizer board. | Check wiring connections. |
| | Damper is jammed. | Identify the obstruction and safely remove. |
| | Minimum position is set incorrectly. | Adjust minimum position setting. |
| | Outdoor-air temperature is above economizer high temperature lockout. | Adjust the high temperature lockout setting if it is incorrect, otherwise, economizer is operating correctly. |
| | Outdoor-air temperature is below economizer low temperature lockout. | Adjust the low temperature lockout setting if it is incorrect, otherwise, economizer is operating correctly. |
| Economizer Position is Less Than Minimum Position. | Outdoor-air thermistor is faulty. | Replace outdoor-air thermistor. |
| | Low suction pressure problem with a compressor. | Economizer is operating correctly, identify compressor problem. |
| | IAQ is controlling minimum damper position. | Adjust the IAQ settings if incorrect, otherwise, the economizer is operating correctly. |
| Economizer Does Not Return to Minimum Position. | Unit is in Unoccupied mode. | Adjust unit occupied schedule if incorrect, otherwise, economizer is operating correctly. |
| | Unit is operating under free cooling. | Economizer is operating correctly. |
| Damper Does Not Close on Power Loss. | Damper is jammed. | Identify the obstruction and safely remove. |
| Outdoor Damper Does Not Fully Close at 0% or Fully Open at 100%. | Economizer actuator is out of calibration. | Enter Service Test mode and run the Calibrate Economizer (E.CAL) procedure. |

LEGEND

- CCN — Carrier Comfort Network®
- IAQ — Indoor Air Quality

Heating Troubleshooting — Use the unit Scrolling Marquee display or a CCN device to view the heating status display and the heating diagnostic display (see Appendix A) for information on the heating operation. Check the current alarms and alarm history for any heating alarm codes and correct any causes (see Table 44). Verify any unique control configurations per installed site requirements or accessories. If alarms conditions are corrected and cleared, operation of the heat stages and indoor fan may be verified by using the Service Test mode (see page 36 and Table 36).

GAS HEAT (48PG UNITS) — See Table 47 for general gas heating service analysis. See Fig. 12 for service analysis of the IGC board logic. Check the status LED on the IGC board for any flashing alarm codes and correct any causes (see Table 48).

ELECTRIC HEAT (50PG UNITS) — See Table 49 for electric heating service analysis.

Phase Loss Protection — The phase loss protection option will monitor the three-phase electrical system to provide phase reversal and phase loss protection.

PHASE REVERSAL PROTECTION — If the control senses an incorrect phase relationship, the relay (K1) will be de-energized (opening its contact). If the phase relationship is correct, the relay will be energized. The control has a self-bypass function after a pre-set time. If the control determines that the three phases stay in a correct relationship for 10 consecutive minutes, the relay will stay energized regardless of the phase sequence of three inputs as long as 24-vac control voltage is applied. This self-bypass function will be reset if all three phases are restored in a phase loss event.

PHASE LOSS PROTECTION — If the reverse rotation board senses any one of the three phase inputs has no AC voltage, the relay will be deenergized (opening its contact). This protection is always active as long as 24-vac control voltage is applied, and is not affected by the self by-pass function of the phase sequence monitoring function. However, in the event of phase loss, the relay will be re-energized only if all three phases are restored and the three phases are in the correct sequence.

A red LED is provided to indicate the function of the board. See the table below.

| LED STATUS | FUNCTION |
|-----------------|---|
| On Continuously | Relay contact closed (normal operation). |
| Blinking | Relay contact open (phase loss or phase reversal has occurred) — No power will be supplied to the control system. |
| Off | 24 vac control power not present (off). |

Thermistor Troubleshooting — The electronic control uses thermistors to sense temperatures used to control operation of the unit. Resistances at various temperatures are listed in Tables 50 and 51. Thermistor pin connection points are shown in the Major System Components section. The general locations of the thermistors are shown the Major System Components section.

AIR TEMPERATURES — Air temperatures are measured with 10 kilo-ohm thermistors. This includes supply-air temperature (SAT), outdoor-air temperature (OAT), space temperature sensors (T55, T56, T58), and return air temperature (RAT).

The supply air temperature (SAT) and outdoor air temperature (OAT) thermistors use a snap-mount to attach through the unit sheet metal panels. The snap-mount tabs must be flattened on the tip end of the sensor to release for removal from the panel. See Fig. 13. To reinstall, make sure the snap-mount tabs extend out.

REFRIGERANT TEMPERATURES — Condenser coil temperatures are measured with 5 kilo-ohm thermistors. These measurements provide an approximate saturated condensing temperature for each circuit (SCT.A, SCT.B). Ensure that thermistors are placed at the correct location and are snapped securely over the return bend so that contact is made between the thermistor and the tube.

THERMISTOR/TEMPERATURE SENSOR CHECK — A high quality digital volt-ohmmeter is required to perform this check.

1. Connect the digital voltmeter across the appropriate thermistor terminals at the J8 terminal strip on the Main Base Board (see Major System Components section).
2. Using the voltage reading obtained, read the sensor temperature from Tables 50 and 51.
3. To check thermistor accuracy, measure temperature at probe location with an accurate thermocouple-type temperature-measuring instrument. Insulate thermocouple to avoid ambient temperatures from influencing reading. Temperature measured by thermocouple and temperature determined from thermistor voltage reading should be close, within 5° F if care was taken in applying thermocouple and taking readings.

Table 47 — Gas Heating Service Analysis

| PROBLEM | CAUSE | REMEDY |
|------------------------------------|--|---|
| Burners Will Not Ignite. | Active alarm. | Check active alarms using <i>ComfortLink™</i> Scrolling Marquee. |
| | No power to unit. | Check power supply, fuses, wiring, and circuit breakers. |
| | No power to IGC (Integrated Gas Control). | Check fuses and plugs. |
| | Heaters off due to time guard to prevent short cycling. | Check using <i>ComfortLink</i> Scrolling Marquee. |
| | Thermostat or occupancy schedule set point not calling for Cooling. | Check using <i>ComfortLink</i> Scrolling Marquee. |
| | No gas at main burners. | Check gas line for air and purge as necessary. After purging gas line of air, allow gas to dissipate for at least 5 minutes before attempting to re-light unit. |
| Inadequate Heating. | Water in gas line. | Drain water and install drip. |
| | Dirty air filters. | Replace air filters. |
| | Gas input too low. | Check gas pressure at manifold. Refer to gas valve adjustment on page 90. |
| | Thermostat or occupancy schedule set point only calling for W1. | Allow time for W2 to energize. |
| | Unit undersized for load. | Decrease load or increase of size of unit. |
| | Restricted airflow. | Remove restriction. |
| | Too much outdoor air. | Check economizer position and configuration. Adjust minimum position using <i>ComfortLink</i> Scrolling Marquee. |
| Limit switch cycles main burners. | Check rotation of blower, thermostat heat anticipator settings, and temperature rise of unit. Adjust as needed. | |
| Poor Flame Characteristics. | Incomplete combustion (lack of combustion air) results in: Aldehyde odors, CO, sooting flame, or floating flame. | Check all screws around flue outlets and burner compartment. Tighten as necessary. |
| | | Cracked heat exchanger, replace. |
| | | Unit is over-fired, reduce input. Adjust gas line or manifold pressure. |
| | | Check vent for restriction. Clean as necessary. |
| Burners Will Not Turn Off. | Check orifice to burner alignment. | |
| | Unit is in Minimum on-time. | Check using <i>ComfortLink</i> Scrolling Marquee. |
| | Unit running in Service Test mode. | Check using <i>ComfortLink</i> Scrolling Marquee. |
| | Main gas valve stuck. | Turn off gas supply and unit power. Replace gas valve. |

Table 48 — IGC Board LED Alarm Codes

| LED FLASH CODE | DESCRIPTION | ACTION TAKEN BY CONTROL | RESET METHOD | PROBABLE CAUSE |
|----------------|-------------------------------------|--|---|--|
| On | Normal Operation | — | — | — |
| Off | Hardware Failure | No gas heating. | — | Loss of power to the IGC. Check 5 amp fuse on IGC, power to unit, 24V circuit breaker, transformer, and wiring to the IGC. |
| 1 Flash | Indoor Fan On/Off Delay Modified | 5 seconds subtracted from On delay. 5 seconds added to Off delay (3 min max). | Power reset. | High temperature limit switch opens during heat exchanger warm-up period before fan-on delay expires. High temperature limit switch opens within 10 minutes of heat call (W) Off. See Limit Switch Fault. |
| 2 Flashes | Limit Switch Fault | Gas valve and igniter Off. Indoor fan and inducer On. | Limit switch closed, or heat call (W) Off. | High temperature limit switch is open. Check the operation of the indoor (evaporator) fan motor. Ensure that the supply-air temperature rise is within the range on the unit nameplate. Check wiring and limit switch operation. |
| 3 Flashes | Flame Sense Fault | Indoor fan and inducer On. | Flame sense normal. Power reset for LED reset. | The IGC sensed a flame when the gas valve should be closed. Check wiring, flame sensor, and gas valve operation. |
| 4 Flashes | Four Consecutive Limit Switch Fault | No gas heating. | Heat call (W) Off. Power reset for LED reset. | 4 consecutive limit switch faults within a single call for heat. See Limit Switch Fault. |
| 5 Flashes | Ignition Fault | No gas heating. | Heat call (W) Off. Power reset for LED reset. | Unit unsuccessfully attempted ignition for 15 minutes. Check igniter and flame sensor electrode spacing, gaps, etc. Check flame sense and igniter wiring. Check gas valve operation and gas supply. |
| 6 Flashes | Induced Draft Motor Fault | If heat off: no gas heating. If heat on: gas valve Off and inducer On. | Inducer sense normal, or heat call (W) Off. | Inducer sense On when heat call Off, or inducer sense Off when heat call On. Check wiring, voltage, and operation of IGC motor. Check speed sensor wiring to IGC. |
| 7 Flashes | Rollout Switch Lockout | Gas valve and igniter Off. Indoor fan and inducer On. | Power reset. | Rollout switch has opened. Check gas valve operation. Check induced-draft blower wheel is properly secured to motor shaft. |
| 8 Flashes | Internal Control Lockout | No gas heating. | Power reset. | IGC has sensed internal hardware or software error. If fault is not cleared by resetting 24 v power, replace the IGC. |
| 9 Flashes | Temporary Software Lockout | No gas heating. | 1 hour auto reset, or power reset. | Electrical interference is disrupting the IGC software. |

LEGEND

IGC — Integrated Gas Unit Control
LED — Light-Emitting Diode

NOTES:

1. There is a 3-second pause between alarm code displays.
2. If more than one alarm code exists, all applicable alarm codes will be displayed in numerical sequence.
3. Alarm codes on the IGC will be lost if power to the unit is interrupted.

Table 49 — Electric Heat Service Analysis

| PROBLEM | CAUSE | REMEDY |
|---|---|---|
| Heat Will Not Turn On. | Active alarm. | Check active alarms using <i>ComfortLink™</i> Scrolling Marquee. |
| | No power to unit. | Check power supply, fuses, wiring, and circuit breakers. |
| | Unit is in minimum heat off-time, or minimum cool-heat changeover time. | Check using <i>ComfortLink</i> Scrolling Marquee. |
| | Thermostat or occupancy schedule setpoint not calling for heating. | Check using <i>ComfortLink</i> Scrolling Marquee. |
| | Heat forced off in Service Test mode. | Check using <i>ComfortLink</i> Scrolling Marquee. Turn Service Test mode off. |
| | No 24 vac at heater contactor. | Check transformer and circuit breaker. |
| | | Check auto-reset limit switches on heater. |
| Check manual-reset limit switch (LS) on heater. | | |
| Open temperature limit switch on heater. | Check minimum airflow. Check limit switch when it is cool, replace if open. | |
| Inadequate Heating. | Dirty air filters. | Replace air filters. |
| | Thermostat or occupancy schedule setpoint only calling for W1. | Allow time for W2 to energize. |
| | Heat undersized for load. | Decrease load or increase size of heater. |
| | Restricted airflow | Remove restriction. |
| | Too much outdoor air. | Check economizer position and configuration. Adjust minimum position. |
| | Limit switch cycles heaters. | Check rotation of blower and minimum airflow. |
| | Bad heater elements. | Power off unit and remove high voltage wires. Check resistance of element, replace if open. |
| Heat Will Not Turn Off. | Unit is in minimum heat on-time. | Check using <i>ComfortLink</i> Scrolling Marquee. |
| | Thermostat or occupancy schedule setpoint still calling for heating. | Check using <i>ComfortLink</i> Scrolling Marquee. |
| | Heat forced on in Service Test mode. | Check using <i>ComfortLink</i> Scrolling Marquee. Turn Service Test mode off. |
| | Heater contactor failed. | Power off unit. Check contactor and replace if closed. |

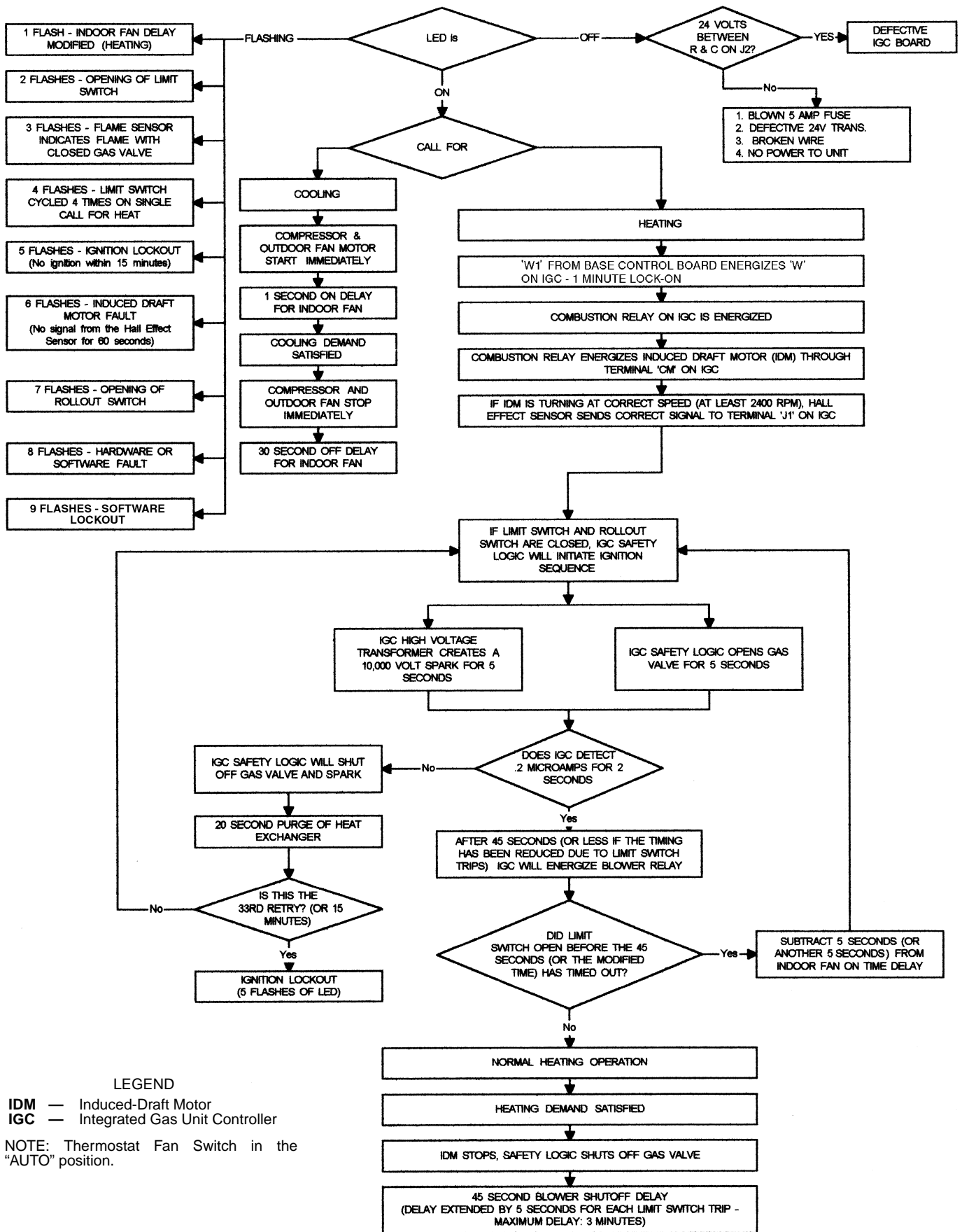

Fig. 12 — IGC Service Analysis Logic

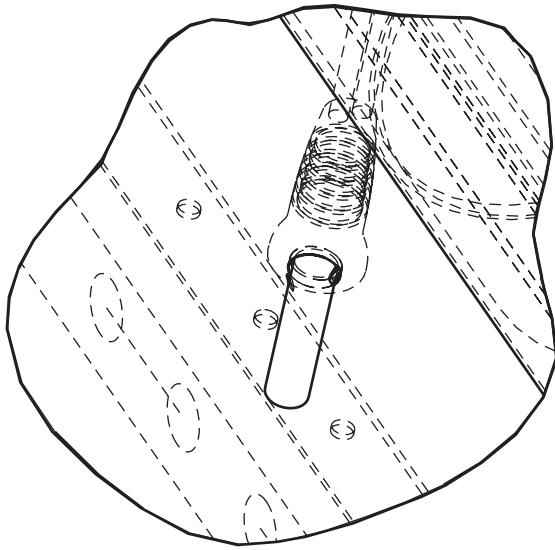

Fig. 13 — SAT and OAT Thermistor Mounting

If a more accurate check is required, unit must be shut down and thermistor removed and checked at a known temperature (freezing point or boiling point of water) using either voltage drop measured across thermistor at the J8 terminal, or by determining the resistance with unit shut down and thermistor disconnected from J8. Compare the values determined with the value read by the control in the Temperatures mode using the Scrolling Marquee display.

SENSOR TRIM — Corrective offsets can be applied to the space temperature and the supply air temperature sensor readings. These corrections are set in the *Configuration* → *TRIM* menu for the display, or in the *Maintenance* → *TRIM* table for CCN. See the Indoor Air Quality section for available

adjustments to IAQ and OAQ sensor readings. The space temperature may be corrected by entering either a calibration temperature value in *SPT.C*, or an offset temperature value in *SPT.T*. The supply-air temperature may be corrected by entering either a calibration temperature value in *SAT.C*, or an offset temperature value in *SAT.T*. Temperature corrections should only be made if sensor readings are compared to an accurate reference temperature measurement device.

Transducer Troubleshooting — The electronic control uses suction pressure transducers to measure the suction pressure of the refrigerant circuits. The pressure/voltage characteristics of these transducers are shown in Table 52. The accuracy of these transducers can be verified by connecting an accurate pressure gage to the second refrigerant port in the suction line.

Forcing Inputs and Outputs — Many variables may have their value forced through CCN or directly at the local display. This can be useful during diagnostic testing and also during operation, typically as part of an advanced third party control scheme. Input and output points that may be forced are indicated as ‘forcible’ in the write status column of the display and CCN tables.

If the user needs to force a variable, follow the same process as when editing a configuration parameter. A forced variable will be displayed on the Scrolling Marquee with a blinking period “.” following its value. A forced value on Navigator™ accessory is indicated with a blinking “f”. A forced value on CCN devices is indicated with “Control” if forced at the unit display, or “Supervisor” if forced via CCN. To remove a local force with the Scrolling Marquee, select the point with the ENTER key and then press the up-arrow and down-arrow keys simultaneously.

NOTE: In the case of a control power reset, any force in effect at the time of power reset will be cleared.

Table 50 — Temperature (°F) vs Resistance/Voltage Drop Values for OAT, SAT, and SPT Thermistors (10K at 25 C Resistors)

| TEMP (F) | VOLTAGE DROP (V) | RESISTANCE (Ohms) | TEMP (F) | VOLTAGE DROP (V) | RESISTANCE (Ohms) | TEMP (F) | VOLTAGE DROP (V) | RESISTANCE (Ohms) |
|----------|------------------|-------------------|----------|------------------|-------------------|----------|------------------|-------------------|
| -25 | 4.758 | 196,453 | 61 | 2.994 | 14,925 | 147 | 0.890 | 2,166 |
| -24 | 4.750 | 189,692 | 62 | 2.963 | 14,549 | 148 | 0.876 | 2,124 |
| -23 | 4.741 | 183,300 | 63 | 2.932 | 14,180 | 149 | 0.862 | 2,083 |
| -22 | 4.733 | 177,000 | 64 | 2.901 | 13,824 | 150 | 0.848 | 2,043 |
| -21 | 4.724 | 171,079 | 65 | 2.870 | 13,478 | 151 | 0.835 | 2,003 |
| -20 | 4.715 | 165,238 | 66 | 2.839 | 13,139 | 152 | 0.821 | 1,966 |
| -19 | 4.705 | 159,717 | 67 | 2.808 | 12,814 | 153 | 0.808 | 1,928 |
| -18 | 4.696 | 154,344 | 68 | 2.777 | 12,493 | 154 | 0.795 | 1,891 |
| -17 | 4.686 | 149,194 | 69 | 2.746 | 12,187 | 155 | 0.782 | 1,855 |
| -16 | 4.676 | 144,250 | 70 | 2.715 | 11,884 | 156 | 0.770 | 1,820 |
| -15 | 4.665 | 139,443 | 71 | 2.684 | 11,593 | 157 | 0.758 | 1,786 |
| -14 | 4.655 | 134,891 | 72 | 2.653 | 11,308 | 158 | 0.745 | 1,752 |
| -13 | 4.644 | 130,402 | 73 | 2.622 | 11,031 | 159 | 0.733 | 1,719 |
| -12 | 4.633 | 126,183 | 74 | 2.592 | 10,764 | 160 | 0.722 | 1,687 |
| -11 | 4.621 | 122,018 | 75 | 2.561 | 10,501 | 161 | 0.710 | 1,656 |
| -10 | 4.609 | 118,076 | 76 | 2.530 | 10,249 | 162 | 0.699 | 1,625 |
| -9 | 4.597 | 114,236 | 77 | 2.500 | 10,000 | 163 | 0.687 | 1,594 |
| -8 | 4.585 | 110,549 | 78 | 2.470 | 9,762 | 164 | 0.676 | 1,565 |
| -7 | 4.572 | 107,006 | 79 | 2.439 | 9,526 | 165 | 0.666 | 1,536 |
| -6 | 4.560 | 103,558 | 80 | 2.409 | 9,300 | 166 | 0.655 | 1,508 |
| -5 | 4.546 | 100,287 | 81 | 2.379 | 9,078 | 167 | 0.645 | 1,480 |
| -4 | 4.533 | 97,060 | 82 | 2.349 | 8,862 | 168 | 0.634 | 1,453 |
| -3 | 4.519 | 94,020 | 83 | 2.319 | 8,653 | 169 | 0.624 | 1,426 |
| -2 | 4.505 | 91,019 | 84 | 2.290 | 8,448 | 170 | 0.614 | 1,400 |
| -1 | 4.490 | 88,171 | 85 | 2.260 | 8,251 | 171 | 0.604 | 1,375 |
| 0 | 4.476 | 85,396 | 86 | 2.231 | 8,056 | 172 | 0.595 | 1,350 |
| 1 | 4.461 | 82,729 | 87 | 2.202 | 7,869 | 173 | 0.585 | 1,326 |
| 2 | 4.445 | 80,162 | 88 | 2.173 | 7,685 | 174 | 0.576 | 1,302 |
| 3 | 4.429 | 77,662 | 89 | 2.144 | 7,507 | 175 | 0.567 | 1,278 |
| 4 | 4.413 | 75,286 | 90 | 2.115 | 7,333 | 176 | 0.558 | 1,255 |
| 5 | 4.397 | 72,940 | 91 | 2.087 | 7,165 | 177 | 0.549 | 1,233 |
| 6 | 4.380 | 70,727 | 92 | 2.059 | 6,999 | 178 | 0.540 | 1,211 |
| 7 | 4.363 | 68,542 | 93 | 2.030 | 6,838 | 179 | 0.532 | 1,190 |
| 8 | 4.346 | 66,465 | 94 | 2.003 | 6,683 | 180 | 0.523 | 1,169 |
| 9 | 4.328 | 64,439 | 95 | 1.975 | 6,530 | 181 | 0.515 | 1,148 |
| 10 | 4.310 | 62,491 | 96 | 1.948 | 6,383 | 182 | 0.507 | 1,128 |
| 11 | 4.292 | 60,612 | 97 | 1.921 | 6,238 | 183 | 0.499 | 1,108 |
| 12 | 4.273 | 58,781 | 98 | 1.894 | 6,098 | 184 | 0.491 | 1,089 |
| 13 | 4.254 | 57,039 | 99 | 1.867 | 5,961 | 185 | 0.483 | 1,070 |
| 14 | 4.235 | 55,319 | 100 | 1.841 | 5,827 | 186 | 0.476 | 1,052 |
| 15 | 4.215 | 53,693 | 101 | 1.815 | 5,698 | 187 | 0.468 | 1,033 |
| 16 | 4.195 | 52,086 | 102 | 1.789 | 5,571 | 188 | 0.461 | 1,016 |
| 17 | 4.174 | 50,557 | 103 | 1.763 | 5,449 | 189 | 0.454 | 998 |
| 18 | 4.153 | 49,065 | 104 | 1.738 | 5,327 | 190 | 0.447 | 981 |
| 19 | 4.132 | 47,627 | 105 | 1.713 | 5,210 | 191 | 0.440 | 964 |
| 20 | 4.111 | 46,240 | 106 | 1.688 | 5,095 | 192 | 0.433 | 947 |
| 21 | 4.089 | 44,888 | 107 | 1.663 | 4,984 | 193 | 0.426 | 931 |
| 22 | 4.067 | 43,598 | 108 | 1.639 | 4,876 | 194 | 0.419 | 915 |
| 23 | 4.044 | 42,324 | 109 | 1.615 | 4,769 | 195 | 0.413 | 900 |
| 24 | 4.021 | 41,118 | 110 | 1.591 | 4,666 | 196 | 0.407 | 885 |
| 25 | 3.998 | 39,926 | 111 | 1.567 | 4,564 | 197 | 0.400 | 870 |
| 26 | 3.975 | 38,790 | 112 | 1.544 | 4,467 | 198 | 0.394 | 855 |
| 27 | 3.951 | 37,681 | 113 | 1.521 | 4,370 | 199 | 0.388 | 841 |
| 28 | 3.927 | 36,610 | 114 | 1.498 | 4,277 | 200 | 0.382 | 827 |
| 29 | 3.903 | 35,577 | 115 | 1.475 | 4,185 | 201 | 0.376 | 814 |
| 30 | 3.878 | 34,569 | 116 | 1.453 | 4,096 | 202 | 0.370 | 800 |
| 31 | 3.853 | 33,606 | 117 | 1.431 | 4,008 | 203 | 0.365 | 787 |
| 32 | 3.828 | 32,654 | 118 | 1.409 | 3,923 | 204 | 0.359 | 774 |
| 33 | 3.802 | 31,752 | 119 | 1.387 | 3,840 | 205 | 0.354 | 762 |
| 34 | 3.776 | 30,860 | 120 | 1.366 | 3,759 | 206 | 0.349 | 749 |
| 35 | 3.750 | 30,009 | 121 | 1.345 | 3,681 | 207 | 0.343 | 737 |
| 36 | 3.723 | 29,177 | 122 | 1.324 | 3,603 | 208 | 0.338 | 725 |
| 37 | 3.697 | 28,373 | 123 | 1.304 | 3,529 | 209 | 0.333 | 714 |
| 38 | 3.670 | 27,597 | 124 | 1.284 | 3,455 | 210 | 0.328 | 702 |
| 39 | 3.654 | 26,838 | 125 | 1.264 | 3,383 | 211 | 0.323 | 691 |
| 40 | 3.615 | 26,113 | 126 | 1.244 | 3,313 | 212 | 0.318 | 680 |
| 41 | 3.587 | 25,396 | 127 | 1.225 | 3,244 | 213 | 0.314 | 670 |
| 42 | 3.559 | 24,715 | 128 | 1.206 | 3,178 | 214 | 0.309 | 659 |
| 43 | 3.531 | 24,042 | 129 | 1.187 | 3,112 | 215 | 0.305 | 649 |
| 44 | 3.503 | 23,399 | 130 | 1.168 | 3,049 | 216 | 0.300 | 639 |
| 45 | 3.474 | 22,770 | 131 | 1.150 | 2,986 | 217 | 0.296 | 629 |
| 46 | 3.445 | 22,161 | 132 | 1.132 | 2,926 | 218 | 0.292 | 620 |
| 47 | 3.416 | 21,573 | 133 | 1.114 | 2,866 | 219 | 0.288 | 610 |
| 48 | 3.387 | 20,998 | 134 | 1.096 | 2,809 | 220 | 0.284 | 601 |
| 49 | 3.357 | 20,447 | 135 | 1.079 | 2,752 | 221 | 0.279 | 592 |
| 50 | 3.328 | 19,903 | 136 | 1.062 | 2,697 | 222 | 0.275 | 583 |
| 51 | 3.298 | 19,386 | 137 | 1.045 | 2,643 | 223 | 0.272 | 574 |
| 52 | 3.268 | 18,874 | 138 | 1.028 | 2,590 | 224 | 0.268 | 566 |
| 53 | 3.238 | 18,384 | 139 | 1.012 | 2,539 | 225 | 0.264 | 557 |
| 54 | 3.208 | 17,904 | 140 | 0.996 | 2,488 | | | |
| 55 | 3.178 | 17,441 | 141 | 0.980 | 2,439 | | | |
| 56 | 3.147 | 16,991 | 142 | 0.965 | 2,391 | | | |
| 57 | 3.117 | 16,552 | 143 | 0.949 | 2,343 | | | |
| 58 | 3.086 | 16,131 | 144 | 0.934 | 2,297 | | | |
| 59 | 3.056 | 15,714 | 145 | 0.919 | 2,253 | | | |
| 60 | 3.025 | 15,317 | 146 | 0.905 | 2,209 | | | |

Table 51 — Temperature (°F) vs. Resistance/Voltage Drop Values for SCT Sensors (5K at 25 C Resistors)

| TEMP (F) | VOLTAGE DROP (V) | RESISTANCE (Ohms) | TEMP (F) | VOLTAGE DROP (V) | RESISTANCE (Ohms) | TEMP (F) | VOLTAGE DROP (V) | RESISTANCE (Ohms) |
|----------|------------------|-------------------|----------|------------------|-------------------|----------|------------------|-------------------|
| -25 | 3.699 | 98,010 | 59 | 1.982 | 7,866 | 143 | 0.511 | 1,190 |
| -24 | 3.689 | 94,707 | 60 | 1.956 | 7,665 | 144 | 0.502 | 1,165 |
| -23 | 3.679 | 91,522 | 61 | 1.930 | 7,468 | 145 | 0.494 | 1,141 |
| -22 | 3.668 | 88,449 | 62 | 1.905 | 7,277 | 146 | 0.485 | 1,118 |
| -21 | 3.658 | 85,486 | 63 | 1.879 | 7,091 | 147 | 0.477 | 1,095 |
| -20 | 3.647 | 82,627 | 64 | 1.854 | 6,911 | 148 | 0.469 | 1,072 |
| -19 | 3.636 | 79,871 | 65 | 1.829 | 6,735 | 149 | 0.461 | 1,050 |
| -18 | 3.624 | 77,212 | 66 | 1.804 | 6,564 | 150 | 0.453 | 1,029 |
| -17 | 3.613 | 74,648 | 67 | 1.779 | 6,399 | 151 | 0.445 | 1,007 |
| -16 | 3.601 | 72,175 | 68 | 1.754 | 6,238 | 152 | 0.438 | 986 |
| -15 | 3.588 | 69,790 | 69 | 1.729 | 6,081 | 153 | 0.430 | 965 |
| -14 | 3.576 | 67,490 | 70 | 1.705 | 5,929 | 154 | 0.423 | 945 |
| -13 | 3.563 | 65,272 | 71 | 1.681 | 5,781 | 155 | 0.416 | 925 |
| -12 | 3.550 | 63,133 | 72 | 1.656 | 5,637 | 156 | 0.408 | 906 |
| -11 | 3.536 | 61,070 | 73 | 1.632 | 5,497 | 157 | 0.402 | 887 |
| -10 | 3.523 | 59,081 | 74 | 1.609 | 5,361 | 158 | 0.395 | 868 |
| -9 | 3.509 | 57,162 | 75 | 1.585 | 5,229 | 159 | 0.388 | 850 |
| -8 | 3.494 | 55,311 | 76 | 1.562 | 5,101 | 160 | 0.381 | 832 |
| -7 | 3.480 | 53,526 | 77 | 1.538 | 4,976 | 161 | 0.375 | 815 |
| -6 | 3.465 | 51,804 | 78 | 1.516 | 4,855 | 162 | 0.369 | 798 |
| -5 | 3.450 | 50,143 | 79 | 1.493 | 4,737 | 163 | 0.362 | 782 |
| -4 | 3.434 | 48,541 | 80 | 1.470 | 4,622 | 164 | 0.356 | 765 |
| -3 | 3.418 | 46,996 | 81 | 1.448 | 4,511 | 165 | 0.350 | 750 |
| -2 | 3.402 | 45,505 | 82 | 1.426 | 4,403 | 166 | 0.344 | 734 |
| -1 | 3.386 | 44,066 | 83 | 1.404 | 4,298 | 167 | 0.339 | 719 |
| 0 | 3.369 | 42,679 | 84 | 1.382 | 4,196 | 168 | 0.333 | 705 |
| 1 | 3.352 | 41,339 | 85 | 1.361 | 4,096 | 169 | 0.327 | 690 |
| 2 | 3.335 | 40,047 | 86 | 1.340 | 4,000 | 170 | 0.322 | 677 |
| 3 | 3.317 | 38,800 | 87 | 1.319 | 3,906 | 171 | 0.317 | 663 |
| 4 | 3.299 | 37,596 | 88 | 1.298 | 3,814 | 172 | 0.311 | 650 |
| 5 | 3.281 | 36,435 | 89 | 1.278 | 3,726 | 173 | 0.306 | 638 |
| 6 | 3.262 | 35,313 | 90 | 1.257 | 3,640 | 174 | 0.301 | 626 |
| 7 | 3.243 | 34,231 | 91 | 1.237 | 3,556 | 175 | 0.296 | 614 |
| 8 | 3.224 | 33,185 | 92 | 1.217 | 3,474 | 176 | 0.291 | 602 |
| 9 | 3.205 | 32,176 | 93 | 1.198 | 3,395 | 177 | 0.286 | 591 |
| 10 | 3.185 | 31,202 | 94 | 1.179 | 3,318 | 178 | 0.282 | 581 |
| 11 | 3.165 | 30,260 | 95 | 1.160 | 3,243 | 179 | 0.277 | 570 |
| 12 | 3.145 | 29,351 | 96 | 1.141 | 3,170 | 180 | 0.272 | 561 |
| 13 | 3.124 | 28,473 | 97 | 1.122 | 3,099 | 181 | 0.268 | 551 |
| 14 | 3.103 | 27,624 | 98 | 1.104 | 3,031 | 182 | 0.264 | 542 |
| 15 | 3.082 | 26,804 | 99 | 1.086 | 2,964 | 183 | 0.259 | 533 |
| 16 | 3.060 | 26,011 | 100 | 1.068 | 2,898 | 184 | 0.255 | 524 |
| 17 | 3.038 | 25,245 | 101 | 1.051 | 2,835 | 185 | 0.251 | 516 |
| 18 | 3.016 | 24,505 | 102 | 1.033 | 2,773 | 186 | 0.247 | 508 |
| 19 | 2.994 | 23,789 | 103 | 1.016 | 2,713 | 187 | 0.243 | 501 |
| 20 | 2.972 | 23,096 | 104 | 0.999 | 2,655 | 188 | 0.239 | 494 |
| 21 | 2.949 | 22,427 | 105 | 0.983 | 2,597 | 189 | 0.235 | 487 |
| 22 | 2.926 | 21,779 | 106 | 0.966 | 2,542 | 190 | 0.231 | 480 |
| 23 | 2.903 | 21,153 | 107 | 0.950 | 2,488 | 191 | 0.228 | 473 |
| 24 | 2.879 | 20,547 | 108 | 0.934 | 2,436 | 192 | 0.224 | 467 |
| 25 | 2.856 | 19,960 | 109 | 0.918 | 2,385 | 193 | 0.220 | 461 |
| 26 | 2.832 | 19,393 | 110 | 0.903 | 2,335 | 194 | 0.217 | 456 |
| 27 | 2.808 | 18,843 | 111 | 0.888 | 2,286 | 195 | 0.213 | 450 |
| 28 | 2.784 | 18,311 | 112 | 0.873 | 2,239 | 196 | 0.210 | 445 |
| 29 | 2.759 | 17,796 | 113 | 0.858 | 2,192 | 197 | 0.206 | 439 |
| 30 | 2.735 | 17,297 | 114 | 0.843 | 2,147 | 198 | 0.203 | 434 |
| 31 | 2.710 | 16,814 | 115 | 0.829 | 2,103 | 199 | 0.200 | 429 |
| 32 | 2.685 | 16,346 | 116 | 0.815 | 2,060 | 200 | 0.197 | 424 |
| 33 | 2.660 | 15,892 | 117 | 0.801 | 2,018 | 201 | 0.194 | 419 |
| 34 | 2.634 | 15,453 | 118 | 0.787 | 1,977 | 202 | 0.191 | 415 |
| 35 | 2.609 | 15,027 | 119 | 0.774 | 1,937 | 203 | 0.188 | 410 |
| 36 | 2.583 | 14,614 | 120 | 0.761 | 1,898 | 204 | 0.185 | 405 |
| 37 | 2.558 | 14,214 | 121 | 0.748 | 1,860 | 205 | 0.182 | 401 |
| 38 | 2.532 | 13,826 | 122 | 0.735 | 1,822 | 206 | 0.179 | 396 |
| 39 | 2.506 | 13,449 | 123 | 0.723 | 1,786 | 207 | 0.176 | 391 |
| 40 | 2.480 | 13,084 | 124 | 0.710 | 1,750 | 208 | 0.173 | 386 |
| 41 | 2.454 | 12,730 | 125 | 0.698 | 1,715 | 209 | 0.171 | 382 |
| 42 | 2.428 | 12,387 | 126 | 0.686 | 1,680 | 210 | 0.168 | 377 |
| 43 | 2.402 | 12,053 | 127 | 0.674 | 1,647 | 211 | 0.165 | 372 |
| 44 | 2.376 | 11,730 | 128 | 0.663 | 1,614 | 212 | 0.163 | 367 |
| 45 | 2.349 | 11,416 | 129 | 0.651 | 1,582 | 213 | 0.160 | 361 |
| 46 | 2.323 | 11,112 | 130 | 0.640 | 1,550 | 214 | 0.158 | 356 |
| 47 | 2.296 | 10,816 | 131 | 0.629 | 1,519 | 215 | 0.155 | 350 |
| 48 | 2.270 | 10,529 | 132 | 0.618 | 1,489 | 216 | 0.153 | 344 |
| 49 | 2.244 | 10,250 | 133 | 0.608 | 1,459 | 217 | 0.151 | 338 |
| 50 | 2.217 | 9,979 | 134 | 0.597 | 1,430 | 218 | 0.148 | 332 |
| 51 | 2.191 | 9,717 | 135 | 0.587 | 1,401 | 219 | 0.146 | 325 |
| 52 | 2.165 | 9,461 | 136 | 0.577 | 1,373 | 220 | 0.144 | 318 |
| 53 | 2.138 | 9,213 | 137 | 0.567 | 1,345 | 221 | 0.142 | 311 |
| 54 | 2.112 | 8,973 | 138 | 0.557 | 1,318 | 222 | 0.140 | 304 |
| 55 | 2.086 | 8,739 | 139 | 0.548 | 1,291 | 223 | 0.138 | 297 |
| 56 | 2.060 | 8,511 | 140 | 0.538 | 1,265 | 224 | 0.135 | 289 |
| 57 | 2.034 | 8,291 | 141 | 0.529 | 1,240 | 225 | 0.133 | 282 |
| 58 | 2.008 | 8,076 | 142 | 0.520 | 1,214 | | | |

Table 52 — Pressure (psig) vs. Voltage Drop Values for Suction Pressure Transducers

| PRESSURE (psig) | VOLTAGE DROP (V) | PRESSURE (psig) | VOLTAGE DROP (V) | PRESSURE (psig) | VOLTAGE DROP (V) | PRESSURE (psig) | VOLTAGE DROP (V) |
|-----------------|------------------|-----------------|------------------|-----------------|------------------|-----------------|------------------|
| 0 | 0.465 | 68 | 1.135 | 136 | 1.804 | 204 | 2.474 |
| 2 | 0.485 | 70 | 1.154 | 138 | 1.824 | 206 | 2.493 |
| 4 | 0.505 | 72 | 1.174 | 140 | 1.844 | 208 | 2.513 |
| 6 | 0.524 | 74 | 1.194 | 142 | 1.863 | 210 | 2.533 |
| 8 | 0.544 | 76 | 1.214 | 144 | 1.883 | 212 | 2.553 |
| 10 | 0.564 | 78 | 1.233 | 146 | 1.903 | 214 | 2.572 |
| 12 | 0.583 | 80 | 1.253 | 148 | 1.922 | 216 | 2.592 |
| 14 | 0.603 | 82 | 1.273 | 150 | 1.942 | 218 | 2.612 |
| 16 | 0.623 | 84 | 1.292 | 152 | 1.962 | 220 | 2.631 |
| 18 | 0.642 | 86 | 1.312 | 154 | 1.982 | 222 | 2.651 |
| 20 | 0.662 | 88 | 1.332 | 156 | 2.001 | 224 | 2.671 |
| 22 | 0.682 | 90 | 1.351 | 158 | 2.021 | 226 | 2.690 |
| 24 | 0.702 | 92 | 1.371 | 160 | 2.041 | 228 | 2.710 |
| 26 | 0.721 | 94 | 1.391 | 162 | 2.060 | 230 | 2.730 |
| 28 | 0.741 | 96 | 1.410 | 164 | 2.080 | 232 | 2.749 |
| 30 | 0.761 | 98 | 1.430 | 166 | 2.100 | 234 | 2.769 |
| 32 | 0.780 | 100 | 1.450 | 168 | 2.119 | 236 | 2.789 |
| 34 | 0.800 | 102 | 1.470 | 170 | 2.139 | 238 | 2.809 |
| 36 | 0.820 | 104 | 1.489 | 172 | 2.159 | 240 | 2.828 |
| 38 | 0.839 | 106 | 1.509 | 174 | 2.178 | 242 | 2.848 |
| 40 | 0.859 | 108 | 1.529 | 176 | 2.198 | 244 | 2.868 |
| 42 | 0.879 | 110 | 1.548 | 178 | 2.218 | 246 | 2.887 |
| 44 | 0.898 | 112 | 1.568 | 180 | 2.237 | 248 | 2.907 |
| 46 | 0.918 | 114 | 1.588 | 182 | 2.257 | 250 | 2.927 |
| 48 | 0.938 | 116 | 1.607 | 184 | 2.277 | 252 | 2.946 |
| 50 | 0.958 | 118 | 1.627 | 186 | 2.297 | 254 | 2.966 |
| 52 | 0.977 | 120 | 1.647 | 188 | 2.316 | 256 | 2.986 |
| 54 | 0.997 | 122 | 1.666 | 190 | 2.336 | 258 | 3.005 |
| 56 | 1.017 | 124 | 1.686 | 192 | 2.356 | 260 | 3.025 |
| 58 | 1.036 | 126 | 1.706 | 194 | 2.375 | 262 | 3.045 |
| 60 | 1.056 | 128 | 1.726 | 196 | 2.395 | 264 | 3.065 |
| 62 | 1.076 | 130 | 1.745 | 198 | 2.415 | 266 | 3.084 |
| 64 | 1.095 | 132 | 1.765 | 200 | 2.434 | 268 | 3.104 |
| 66 | 1.115 | 134 | 1.785 | 202 | 2.454 | 270 | 3.124 |

MAJOR SYSTEM COMPONENTS

General — The 48/50PG single-package rooftop units contain the *ComfortLink*™ electronic control system that monitors all operations of the rooftop. The control system is composed of several main control components and available factory-installed options or field-installed accessories as listed in sections below. See Fig. 14-19 for the control and power schematics. Figures 20 and 21 show the layout of the control box, unit, and thermistor and transducer locations.

Main Base Board (MBB) — See Fig. 22 and Table 53. The MBB is the center of the *ComfortLink* control system. It contains the major portion of the operating software and controls the operation of the unit. The MBB continuously monitors input/output channel information received from its inputs and from the Economizer Control Board (ECB). The MBB receives inputs from thermistors and transducers. The MBB also receives the Current Sensor inputs for compressors and other discrete or digital inputs. The MBB reads space temperature (SPT) from either a T-55, T-56 or T-58 device and space temperature offset (SPTO) from a T-56 device. See Field-Installed Accessories section on page 82. The MBB controls 9 relays.

NOTE: The Main Base Board (MBB) has a 3-position instance jumper that is factory set to '1'. **Do not change this setting.**

Economizer Control Board (ECB) — The ECB controls the economizer actuator. See Fig. 23 and Table 54. The control signal from the ECB uses either the MFT (Multi-Function Technology) communication protocol or a 4 to 20 mA output signal as defined by the configuration

Configuration→*ECON*→*E.CTL*. The ECB has inputs for Indoor Air Quality (IAQ), Outdoor Air Quality (OAQ), and enthalpy. It also controls two power exhaust outputs.

By digitally communicating with the ECB, the economizer actuator is able to provide the damper position and diagnostic information to the *ComfortLink* controller. The damper position is displayed at *Outputs*→*ECON*→*EC.AP*. Diagnostic information is displayed via Alert T414. More information about these alarms is contained in the Alarms and Alerts section.

NOTE: The Economizer Control Board (ECB) has a 4-position DIP switch that is factory set to ON (towards the center of the board). **Do not change this setting.**

Integrated Gas Control (IGC) Board — The IGC is provided on gas heat units. See Table 55 and Fig. 24. The IGC controls the direct spark ignition system and monitors the rollout switch, limit switch, and induced-draft motor Hall Effect switch. The IGC is equipped with an LED (light-emitting diode) for diagnostics. See the Troubleshooting section for more information.

Low Voltage Terminal Strip (TB2) — This circuit board provides a connection point between the major control boards and a majority of the field-installed accessories. See Fig. 25 and Table 56. The interface connection for the Carrier Comfort Network® (CCN) communication and interface connection for the Local Equipment Network (LEN) communications are also located on the low voltage terminal strip.

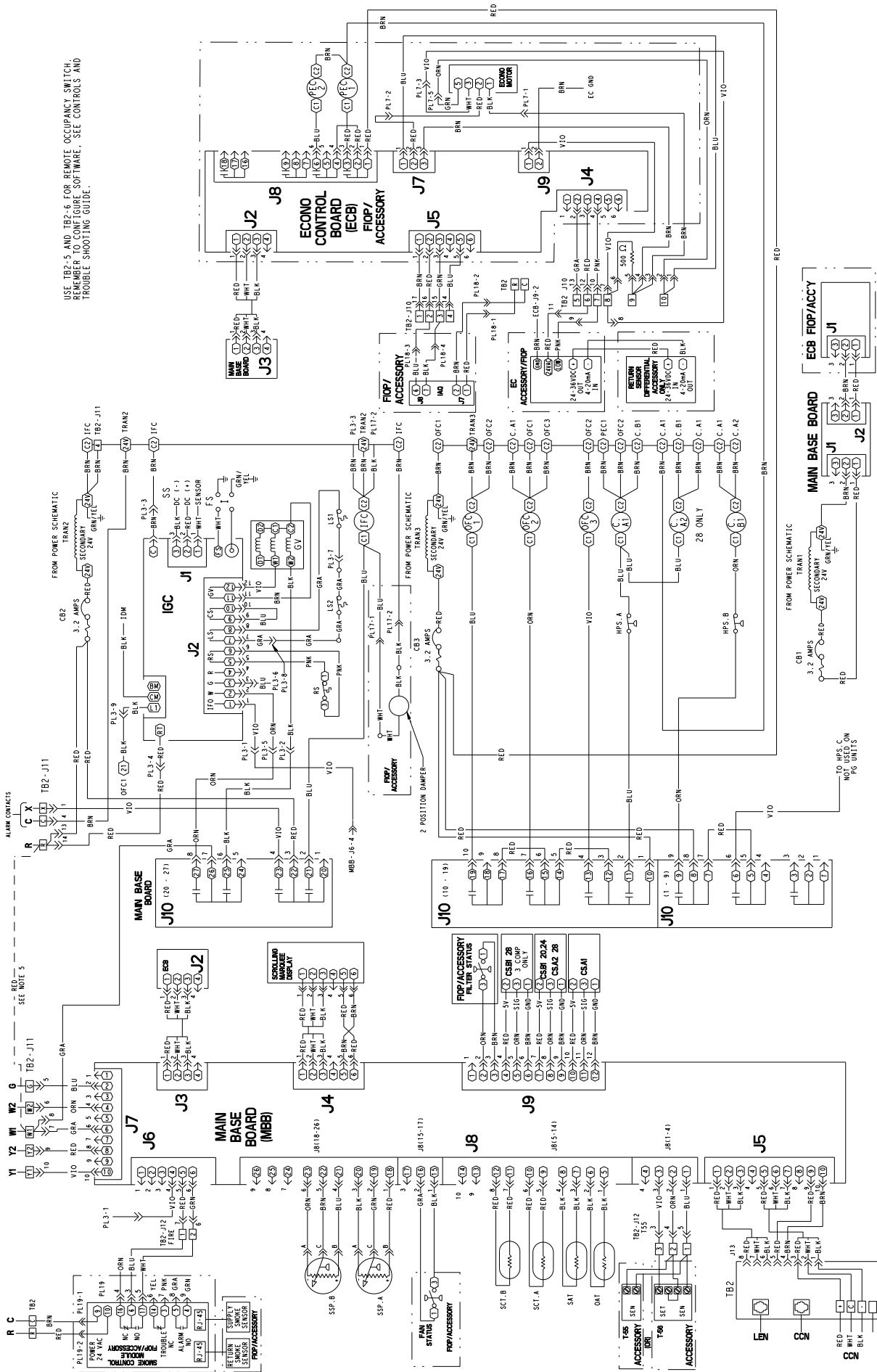

Fig. 14 — Low Voltage Control Schematic — 48PG20-28 Units without Humidi-Mizer™ System

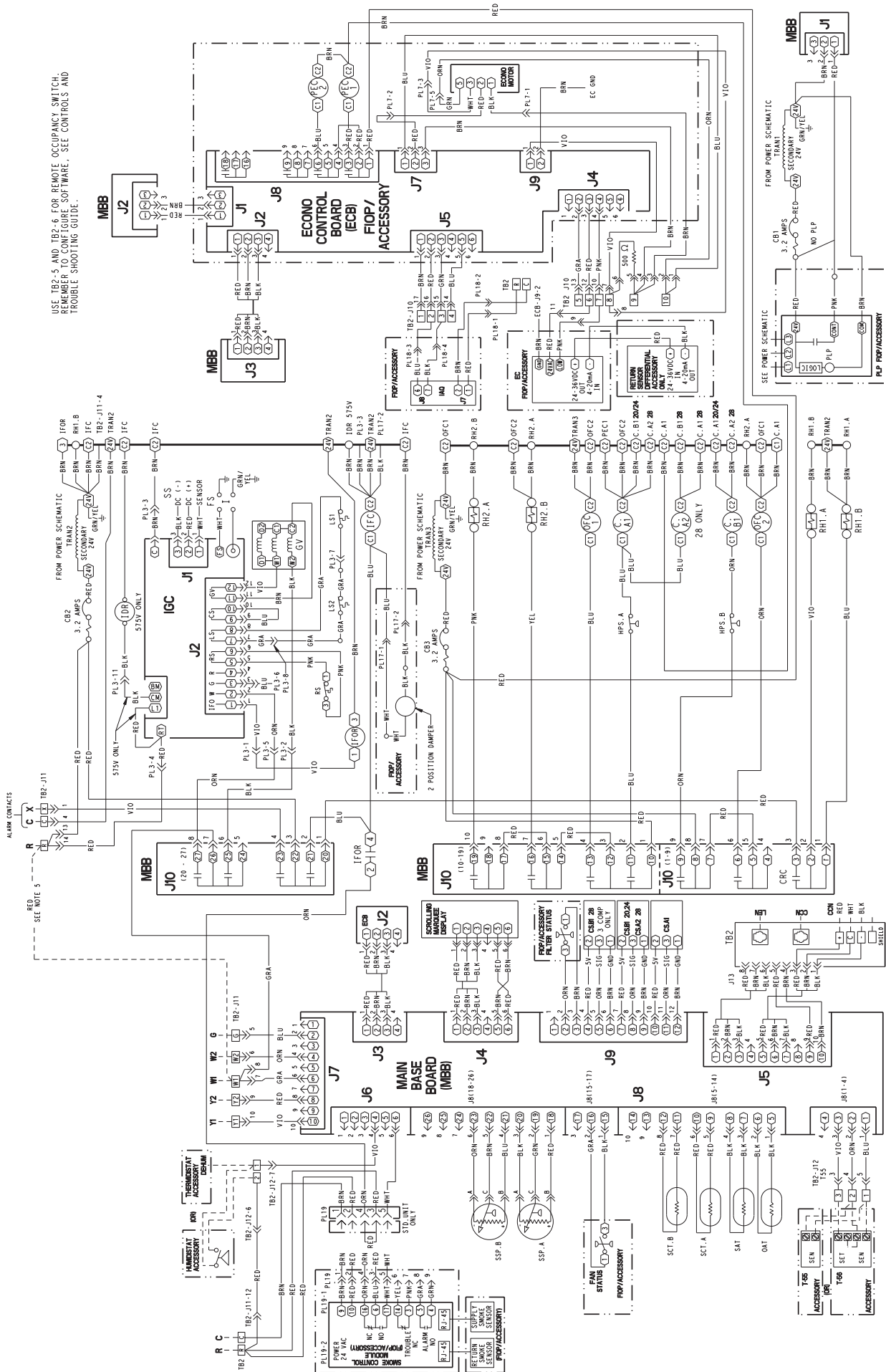

Fig. 15 — Low Voltage Control Schematic — 48PG20-28 Units with Humidi-Mizer™ System

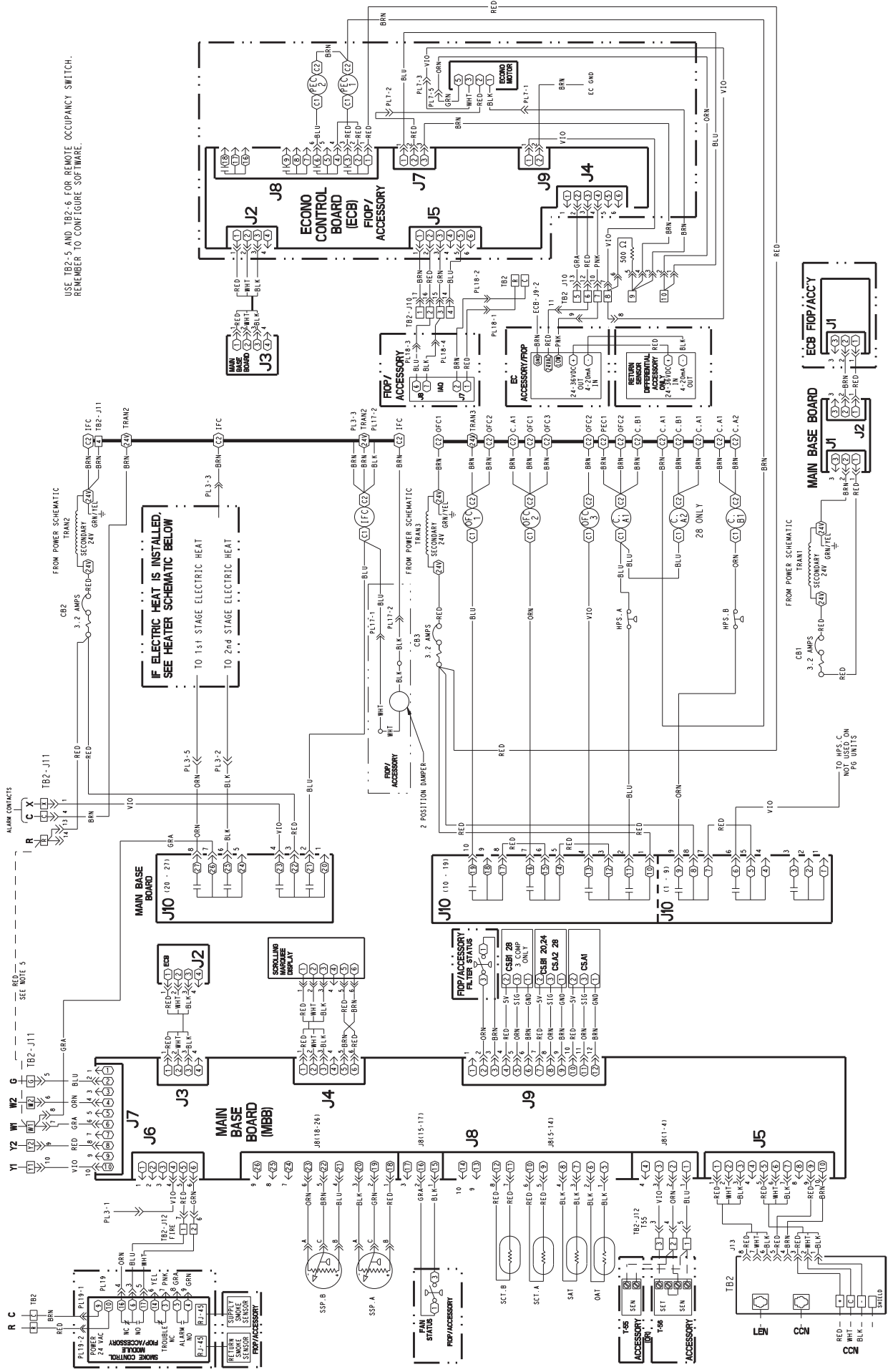
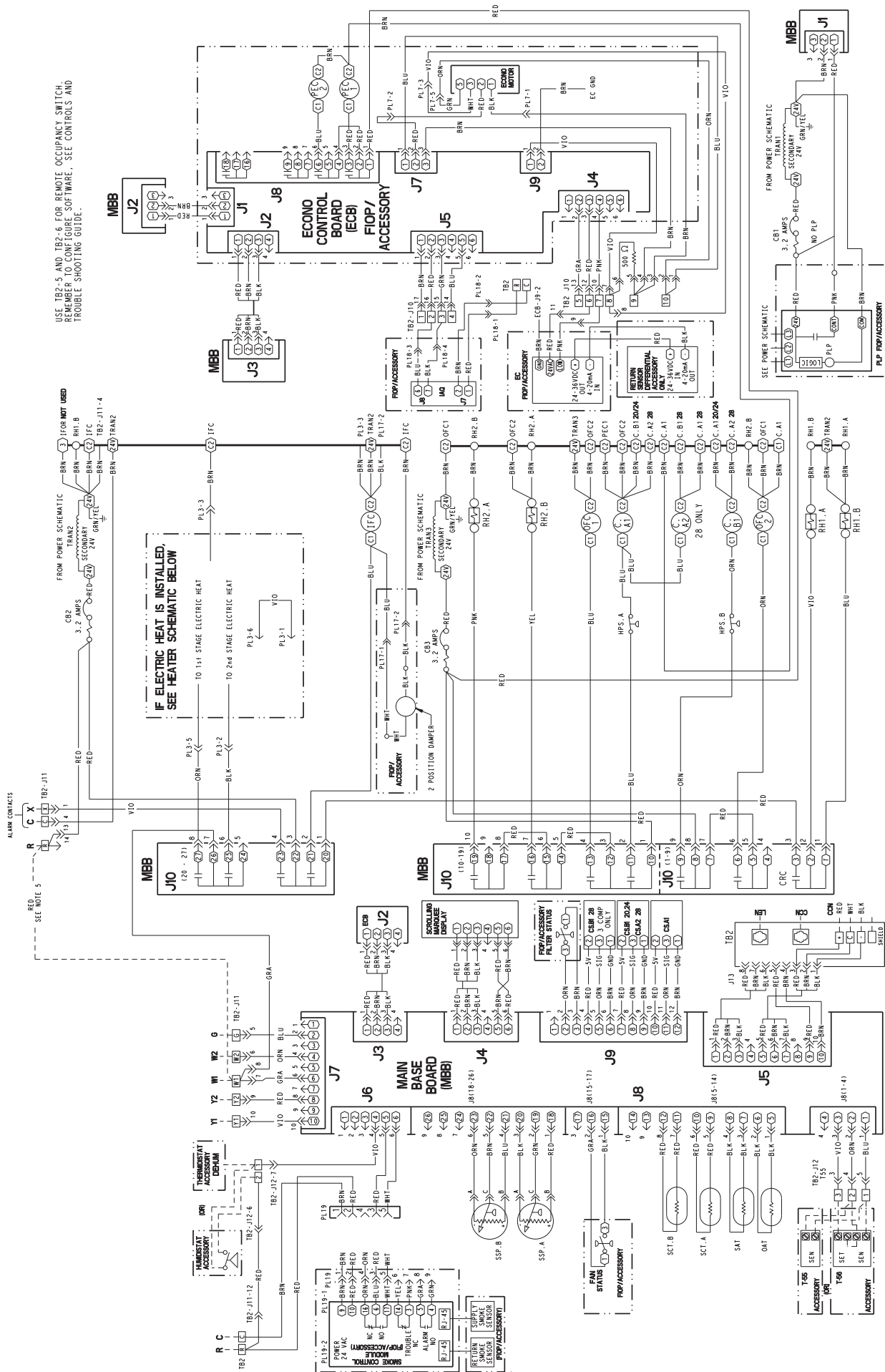

Fig. 16 — Low Voltage Control Schematic — 50PG20-28 Units without Humidi-Mizer™ System



USE TB2-5 AND TB2-6 FOR REMOTE OCCUPANCY SWITCH. REMEMBER TO CONFIGURE SOFTWARE. SEE CONTROLS AND TROUBLE SHOOTING GUIDE.

IF ELECTRIC HEAT IS INSTALLED, SEE HEATER SCHEMATIC BELOW

Fig. 17 — Low Voltage Control Schematic — 50PG20-28 Units with Humidi-Mizer™ System

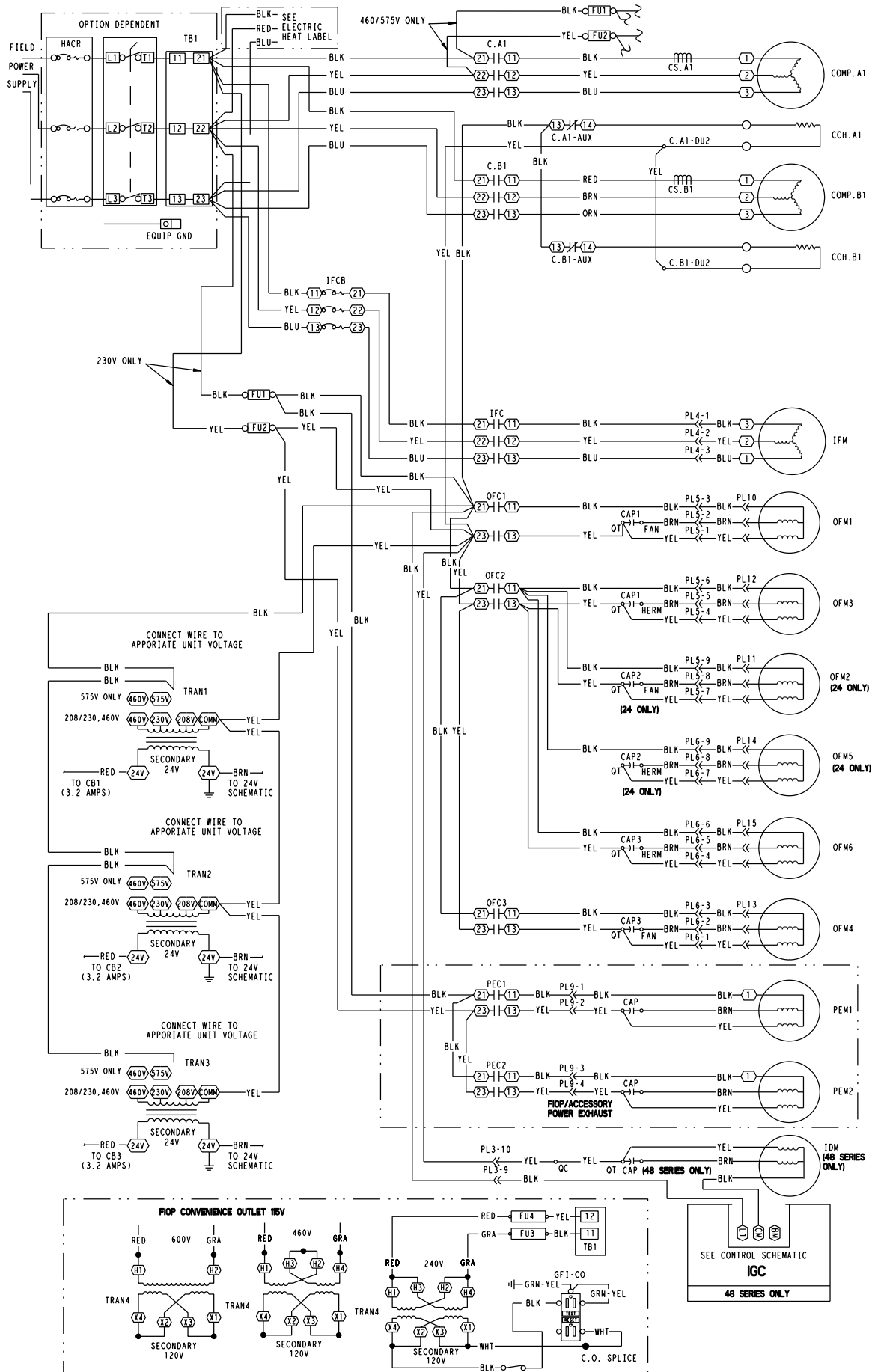

Fig. 18 — Power Schematic — Units without Humidi-MiZer™ System

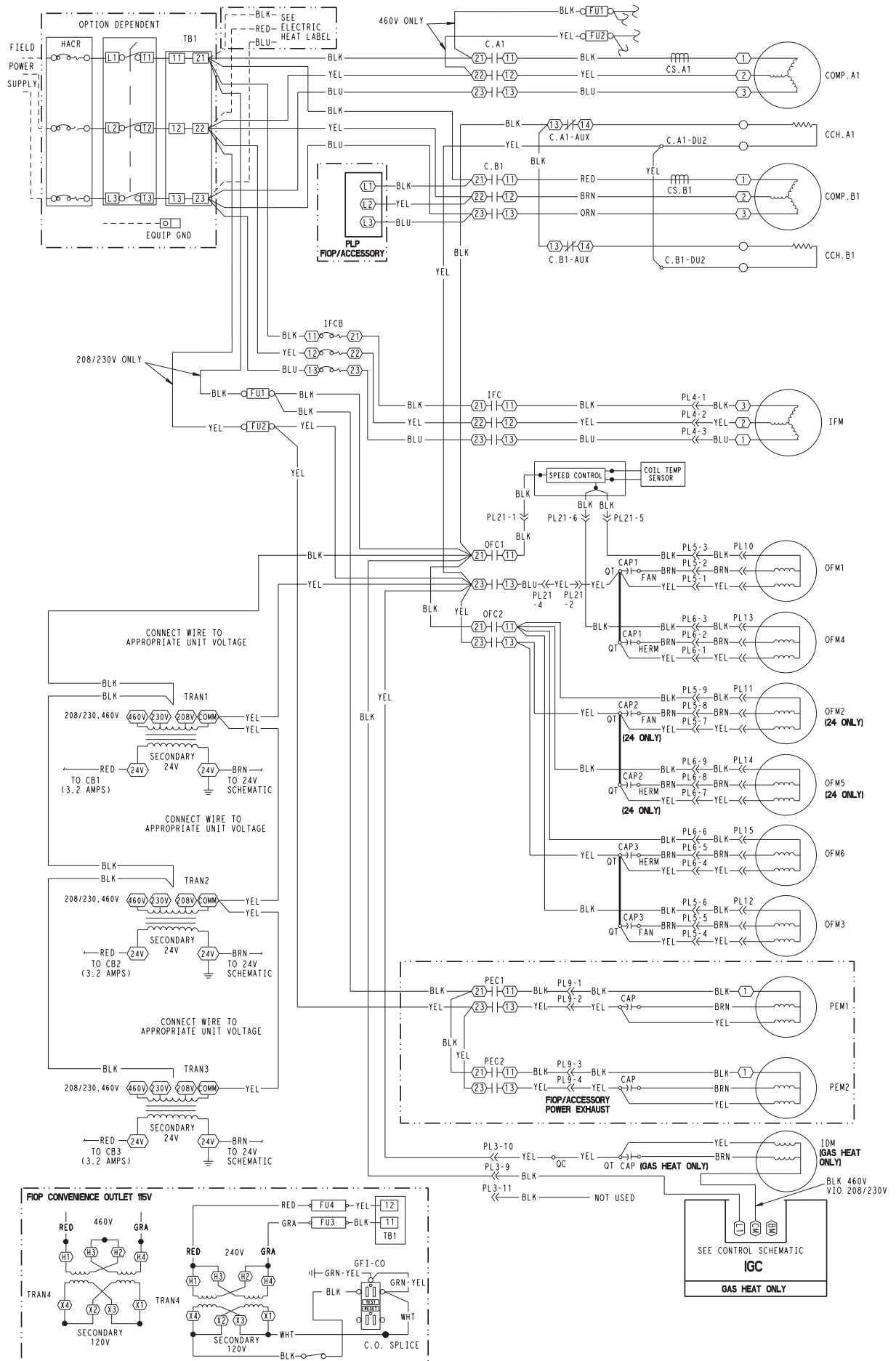

Fig. 19 — Power Schematic — Units with Humidi-MiZer™ System

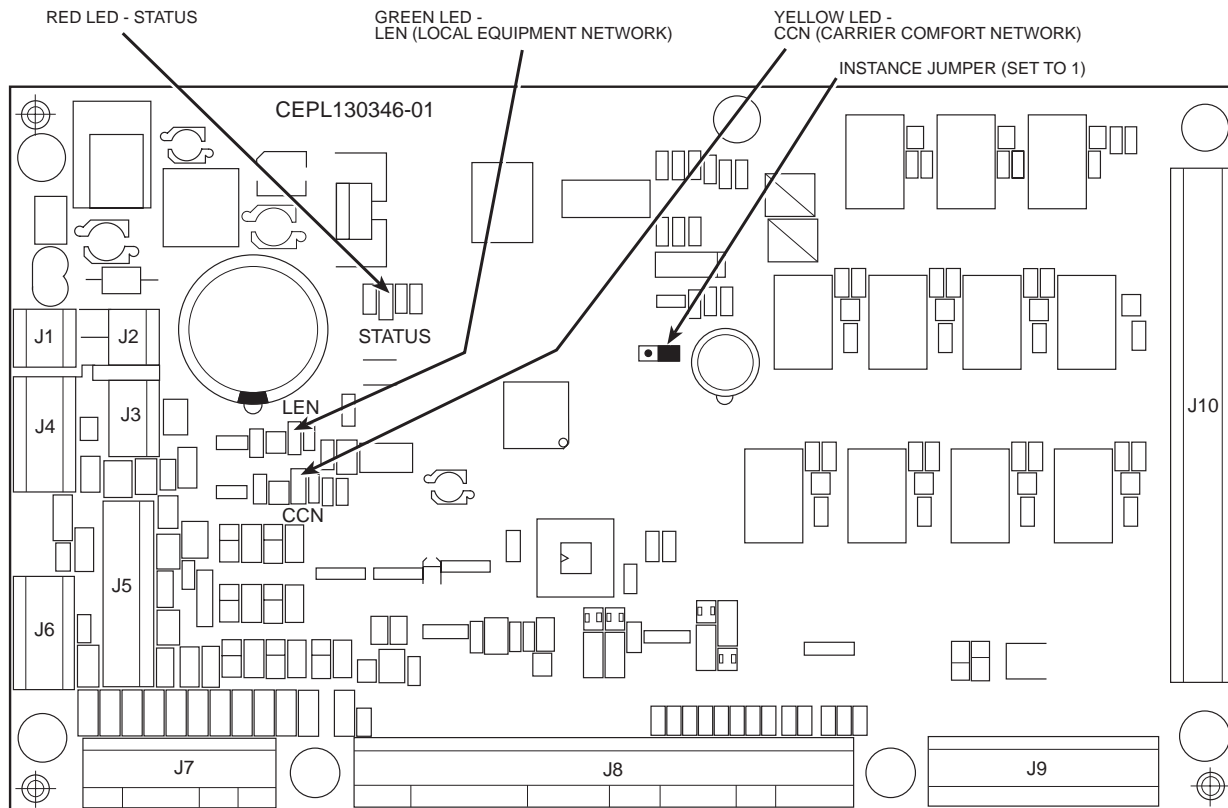

Fig. 22 — Main Base Board (MBB)

Table 53 — MBB Connections

| DISPLAY NAME | POINT DESCRIPTION | SENSOR LOCATION | TYPE OF I/O | CONNECTION PIN NUMBER |
|-----------------------|--|------------------------------------|----------------|-----------------------|
| INPUTS | | | | |
| | Input power from TRAN1 | control box | 24 VAC | J1, 1-3 |
| HUM | Indoor fan output feedback (IGC), or Space humidity switch | gas section space | switch input | J6, 4 |
| FDWN | Fire shutdown switch | supply/return/space | switch input | J6, 5-6 |
| G | Thermostat G (Fan) | space | switch input | J7, 2 |
| W2 | Thermostat W2 (2nd Stage Heat) | space | switch input | J7, 4 |
| W1 | Thermostat W1 (1st Stage Heat) | space | switch input | J7, 6 |
| Y2 | Thermostat Y2 (2nd Stage Cool) | space | switch input | J7, 8 |
| Y1 | Thermostat Y1 (1st Stage Cool) | space | switch input | J7, 10 |
| SPT | Space temperature (T55/56) | space | 10k thermistor | J8, 1-2 |
| SPTO or RAT | Space temperature offset (T56), or Return air temperature | space return | 10k thermistor | J8, 2-3 |
| OAT | Outdoor air temperature | outdoor coil support | 10k thermistor | J8, 5-6 |
| SAT | Supply air temperature | indoor fan housing, or supply duct | 10k thermistor | J8, 7-8 |
| SCT.A | Saturated condenser temperature, circuit A | outdoor coil, circuit A | 5k thermistor | J8, 9-10 |
| SCT.B | Saturated condenser temperature, circuit B | outdoor coil, circuit B | 5k thermistor | J8, 11-12 |
| SCT.C | Saturated condenser temperature, circuit C | outdoor coil, circuit C | 5k thermistor | J8, 13-14 |
| FAN.S | Fan status switch | indoor fan section | switch input | J8, 15-16 |
| SSPA | Suction pressure, circuit A | compressor A suction | analog input | J8, 18-20 |
| SSPB | Suction pressure, circuit B | compressor B suction | analog input | J8, 21-23 |
| SSPC | Suction pressure, circuit C | compressor C suction | analog input | J8, 24-26 |
| FIL.S | Filter status switch | indoor fan section | switch input | J9, 2-3 |
| CS.A1 | Compressor A1 feedback | control box | digital input | J9, 4-6 |
| CS.B1 or CS.A2 | Compressor B1 feedback, or Compressor A2 feedback | control box | digital input | J9, 7-9 |
| CS.C1 or CS.B1 | Compressor C1 feedback, or Compressor B1 feedback | control box | digital input | J9, 10-12 |
| OUTPUTS | | | | |
| | Output power to ECB | | 24 VAC | J2, 1-2 |
| | Output power to Marquee Display | | 24 VAC | J4, 5-6 |
| CRC | Cool-Reheat1 control | | relay | J10, 3 |
| CMPC or OFC.2 | Compressor C1 relay, or Outdoor fan 2 relay | | relay | J10, 6 |
| CMPB | Compressor B1 relay | | relay | J10, 9 |
| CMPA | Compressor A1 relay | | relay | J10, 11 |
| CCH or OFC.3 or OFC.1 | Crankcase heat relay, or Outdoor fan 3 relay, or Outdoor fan 1 relay | | relay | J10, 13 |
| OFC.2 or RH2.B | Outdoor fan 2 relay, or Reheat2 valve, circuit B and C | | relay | J10, 16 |
| OFC.1 or RH2.A | Outdoor fan 1 relay, or Reheat2 valve, circuit A | | relay | J10, 19 |
| IDF | Indoor fan relay | | relay | J10, 21 |
| ALRM | Alarm relay | | relay | J10, 23 |
| HT.1 | Heat stage 1 relay | | relay | J10, 25 |
| HT.2 | Heat stage 2 relay | | relay | J10, 27 |
| COMMUNICATION | | | | |
| | Local Equipment Network (LEN) | | communication | J5, 1-3 |
| | Carrier Comfort Network (CCN) | | communication | J5, 5-7 |
| | Network device power | | 24 VAC | J5, 9-10 |

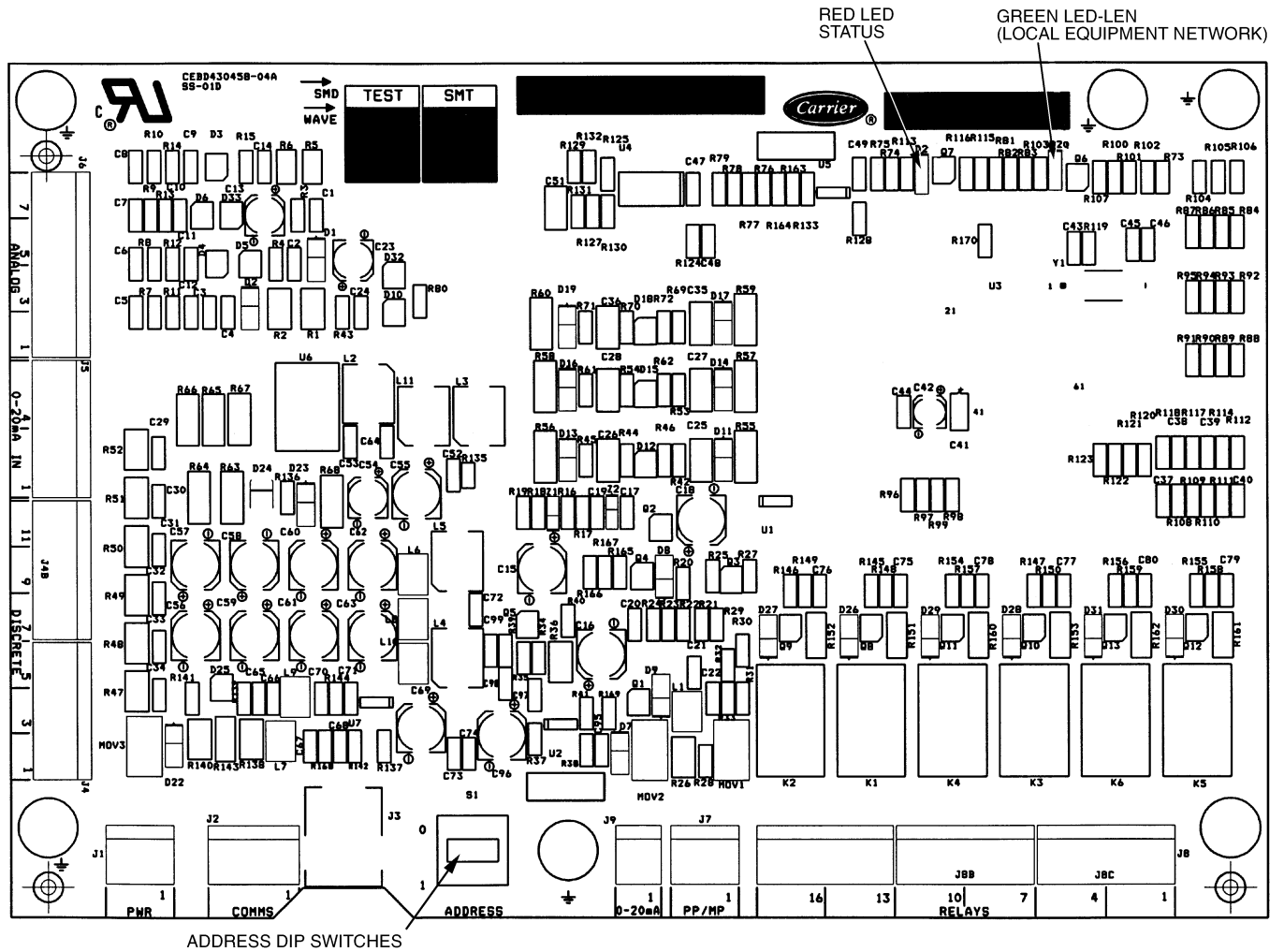

Fig. 23 — Economizer Control Board (ECB)

Table 54 — ECB Connections

| DISPLAY NAME | POINT DESCRIPTION | SENSOR LOCATION | TYPE OF I/O | CONNECTION PIN NUMBER |
|----------------------|---|----------------------------|---------------|-----------------------|
| INPUTS | | | | |
| | Input power from MBB | control box | 24 VAC | J1, 1-2 |
| RM.OC | Remote occupancy switch | field installed | switch input | J4, 2-3 |
| ENTH or IAQ.S | Outdoor enthalpy switch, or Indoor air quality switch | economizer space or return | switch input | J4, 4-3 |
| IAQ | Indoor air quality sensor | space or return | 4-20 mA | J5, 2-3 |
| OAQ or SPRH | Outdoor air quality sensor, or Space humidity sensor | economizer space | 4-20 mA | J5, 4-3 |
| OUTPUTS | | | | |
| PE.1 | Power exhaust 2 relay | | relay | J8, 3 |
| PE.2 | Power exhaust 2 relay | | relay | J8, 6 |
| EC.CP or EC.AP | Economizer actuator (analog, digital) | | 4-20 mA | J9, 1 |
| COMMUNICATION | | | | |
| | Local Equipment Network (LEN) | | communication | J2, 1-3 |
| EC.CP and EC.AP | Economizer actuator (digital control) | | communication | J7, 1-3 |

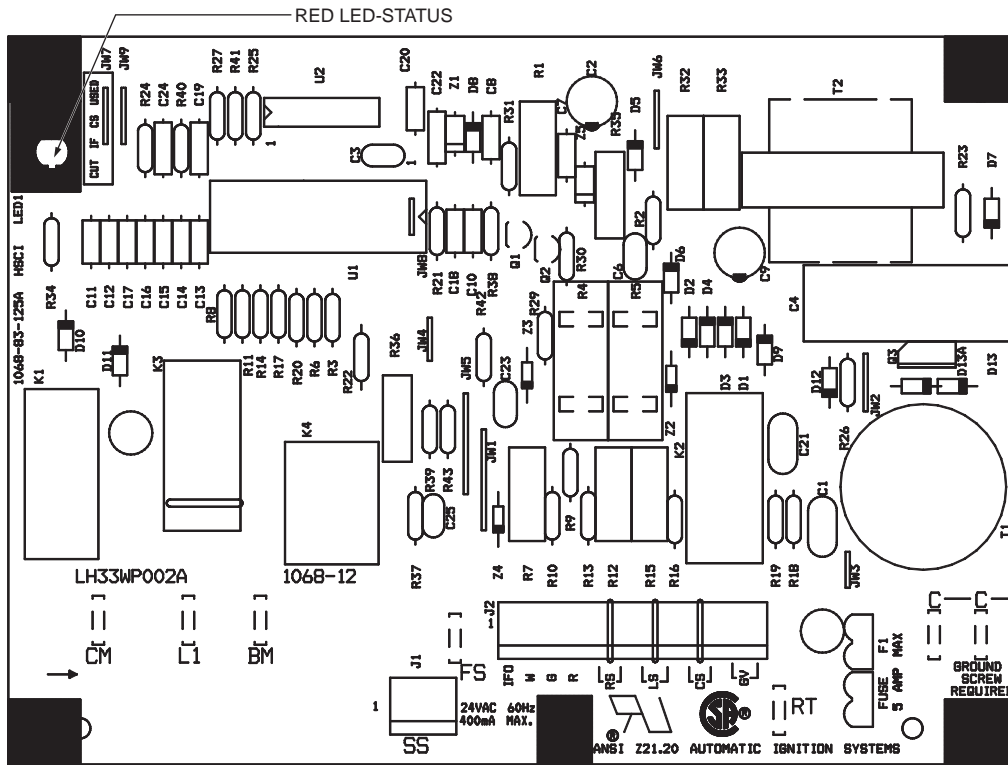

Fig. 24 — Integrated Gas Control (IGC) Board

Table 55 — IGC Connections

| TERMINAL LABEL | POINT DESCRIPTION | SENSOR LOCATION | TYPE OF I/O | CONNECTION PIN NUMBER |
|----------------|--------------------------------|-----------------|--------------|-----------------------|
| INPUTS | | | | |
| RT, C | Input power from TRAN 1 | control box | 24 VAC | — |
| SS | Speed sensor | gas section | analog input | J1, 1-3 |
| FS, T1 | Flame sensor | gas section | switch input | — |
| W | Heat stage 1 | MBB | 24 VAC | J2, 2 |
| RS | Rollout switch | gas section | switch input | J2, 5-6 |
| LS | Limit switch | gas section | switch input | J2, 7-8 |
| CS | Centrifugal switch (not used) | — | switch input | J2, 9-10 |
| OUTPUTS | | | | |
| L1, CM | Induced draft combustion motor | gas section | line VAC | |
| IFO | Indoor fan | MBB | relay | J2, 1 |
| GV | Gas valve (heat stage 1) | gas section | relay | J2, 11-12 |

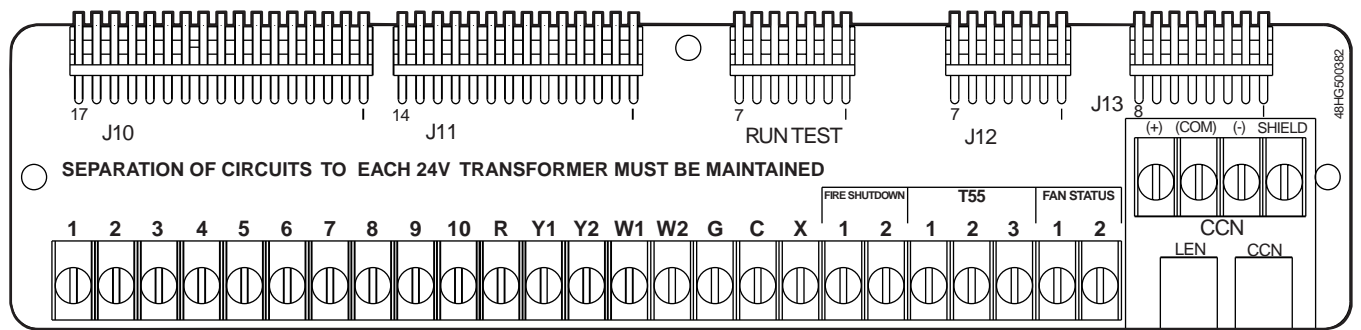

Fig. 25 — Low-Voltage Terminal Strip

Table 56 — Field Connection Terminal Strip

| TERMINAL LABEL | DISPLAY NAME | POINT DESCRIPTION | SENSOR LOCATION | TYPE OF I/O | CONNECTION PIN NUMBER |
|---|-------------------------|---|------------------------------|------------------------------------|-----------------------|
| 1 | | 24 VAC power | | 24 VAC output | J10, 17 |
| 2 | IAQ | Indoor air quality sensor | return/space | 4-20 mA input | J10, 16 |
| 3 | | Indoor & outdoor air quality common | | 4-20 mA input | J10, 15 |
| 4 | OAQ or SP.RH | Outdoor air quality sensor, or Space humidity sensor | economizer space | 4-20 mA input | J10, 14 |
| 5 | RM.OC | Remote occupancy switch | field installed | 24 VAC input | J10, 13 |
| 6 | | Outdoor enthalpy switch power | economizer | 24 VAC input | J10, 11-12 |
| 7 | ENTH or IAQ.S | Outdoor enthalpy switch, or Indoor air quality switch | economizer, or return/space | 24 VAC input | J10, 9-10 |
| 8 | EC.CP or EC.AP EC.CP | Economizer actuator (digital control) Economizer actuator (analog control) | economizer | 2-10 VDC output 2-10 VDC output | J10, 6-8 |
| 9 | | Economizer signal common | economizer | VDC | J10, 3-5 |
| 10 | EC.CP EC.AP | Economizer actuator (digital control) Economizer actuator (analog control) | economizer | communication 2-10 VDC output | J10, 1-2 |
| R | | 24 VAC power | | 24 VAC output | J11, 11-14 |
| Y1 | Y1 | Thermostat Y1 (1st stage cool) | space | 24 VAC input | J11,10 |
| Y2 | Y2 | Thermostat Y2 (2nd stage cool) | space | 24 VAC input | J11, 9 |
| W1 | W1 | Thermostat W1 (1st stage heat) | space | 24 VAC input | J11, 7-8 |
| W2 | W2 | Thermostat W2 (2nd stage heat) | space | 24 VAC input | J11, 6 |
| G | G | Thermostat G (Fan) | space | 24 VAC input | J11, 5 |
| C | | 24 VAC common | | 24 VAC output | J11, 2-4 |
| X | ALRM | Alarm output (normally open) | | 24 VAC output | J11, 1 |
| FIRE SHUTDOWN 1-2, or HUMIDISTAT 1-2* | FDWN HUM | Fire shutdown switch Space humidity switch | supply/return/space space | switch input | J12, 6-7 |
| T55 1-2 | SPT | Space temperature (T55/56) | space | 10k thermistor | J12, 4-5 |
| T55 2-3 | SPTO or RAT | Space temperature offset (T56) or Return air temperature | space or return | 10k thermistor | J12, 3-4 |
| LEN | | Local Equipment Network (LEN) | | communication | J13, 1-3, 4-5 |
| CCN | | Carrier Comfort Network (CCN) | | communication | J13, 6-8, 4-5 |

*Refer to Third Party Control section on page 38 for information on wiring fire shutdown with a Humidi-MiZer™ system.

Scrolling Marquee Display — This device is the keypad interface used to access rooftop information, read sensor values, and test the unit. See Fig. 26. The Scrolling Marquee display is a 4-key, 4-character, 16-segment LED (light-emitting diode) display. Eleven mode LEDs are located on the display as well as an Alarm Status LED. See Scrolling Marquee section on page 2 for further details.

Accessory Navigator™ Display — The accessory hand-held Navigator display can be used with the 48/50PG series units. See Fig. 27. The Navigator display operates the same way as the Scrolling Marquee device. The Navigator display plugs into the LEN port on either TB2 or the ECB board.

Carrier Comfort Network® (CCN) Interface — The 48/50PG units can be connected to the CCN if desired. The communication bus wiring is a shielded, 3-conductor cable with drain wire and is field supplied and installed. The system elements are connected to the communication bus in a daisy chain arrangement. See Fig. 28. The positive pin of each system element communication connector must be wired to the positive pins of the system elements on either side of it. This is also required for the negative and signal ground pins of each system element. Wiring connections for CCN should be made at TB2. See Fig. 14-17. Consult the CCN Contractor's Manual for further information.

NOTE: Conductors and drain wire must be 20 AWG (American Wire Gage) minimum stranded, tinned copper. Individual conductors must be insulated with PVC, PVC/nylon, vinyl, Teflon, or polyethylene. An aluminum/polyester 100% foil shield and an outer jacket of PVC, PVC/nylon, chrome vinyl, or Teflon with a minimum operating temperature range of -20 C to 60 C is required. See the table below for acceptable wiring.

| MANUFACTURER | PART NO. |
|--------------|--------------|
| Alpha | 2413 or 5463 |
| Belden | 8772 |
| Carol | C2528 |
| West Penn | 302 |

It is important when connecting to a CCN communication bus that a color-coding scheme be used for the entire network to simplify the installation. It is recommended that red be used for the signal positive, black for the signal negative and white for the signal ground. Use a similar scheme for cables containing different colored wires.

At each system element, the shields of its communication bus cables must be tied together. The shield screw on TB2 can be used to tie the cables together. If the communication bus is entirely within one building, the resulting continuous shield must be connected to a ground at one point only. The shield screw on TB2 is not acceptable for grounding. If the communication bus cable exits from one building and enters another, the shields must be connected to grounds at the lightning suppressor in each building where the cable enters or exits the building (one point per building only). To connect the unit to the network:

1. Turn off power to the control box.
2. Cut the CCN wire and strip the ends of the red (+), white (ground), and black (-) conductors. (Substitute appropriate colors for different colored cables.)
3. Connect the red wire to (+) terminal on TB2, the white wire to COM terminal, and the black wire to the (-) terminal.
4. The RJ14 CCN connector on TB2 can also be used, but is only intended for temporary connection (for example, a laptop computer running Carrier network software).

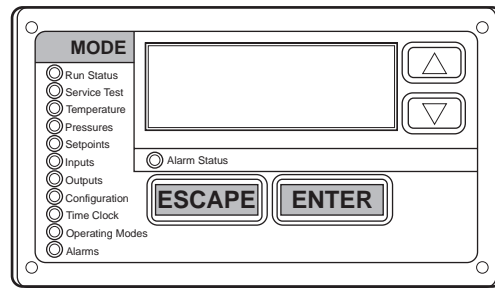

Fig. 26 — Scrolling Marquee

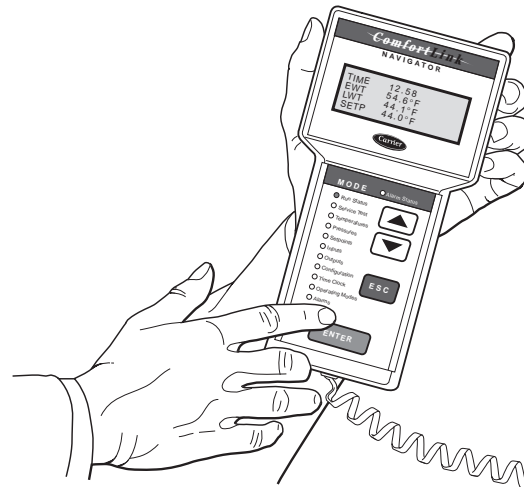

Fig. 27 — Accessory Navigator™ Display

5. Restore power to unit.

IMPORTANT: A shorted CCN bus cable will prevent some routines from running and may prevent the unit from starting. If abnormal conditions occur, unplug the connector. If conditions return to normal, check the CCN connector and cable. Run new cable if necessary. A short in one section of the bus can cause problems with all system elements on the bus.

Subcooler Heat Exchanger (SHX) — The purpose of the subcooler heat exchanger (SHX) and the subcooler TXV is to increase the capacity of the evaporator by sending subcooled liquid refrigerant into the evaporator. Normally, the condenser subcools the liquid refrigerant by approximately 10 F. The SHX adds another 10 F to 15 F degrees of subcooling before the refrigerant reaches the evaporator. This allows the refrigerant to absorb more heat from the mixed air, thereby providing more cooling capacity.

The subcooler functions by taking a small percentage of the high pressure, medium temperature liquid refrigerant which exits the condenser and converting it into a low pressure, low temperature gas. This is accomplished by using the subcooler TXV. The gas is then routed through a reverse-flow heat exchanger (SHX), which transfers heat from the remaining liquid refrigerant in the liquid line to the reverse flow gas refrigerant. The moderate temperature gas is then sent to the compressor to complete the loop and the cooler liquid refrigerant continues its normal path to the main TXV and the evaporator. See Fig. 29.

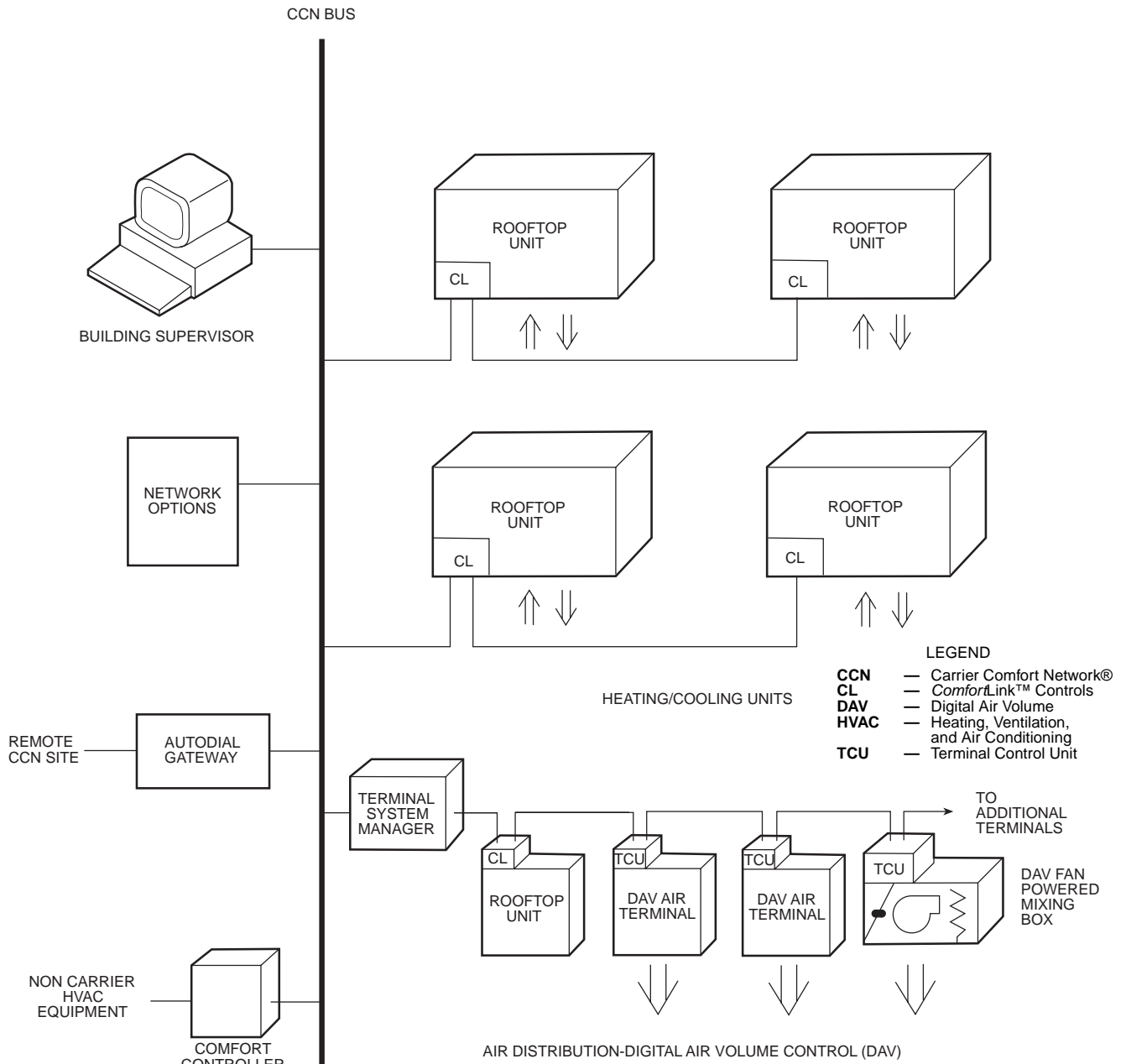

Fig. 28 — CCN System Architecture

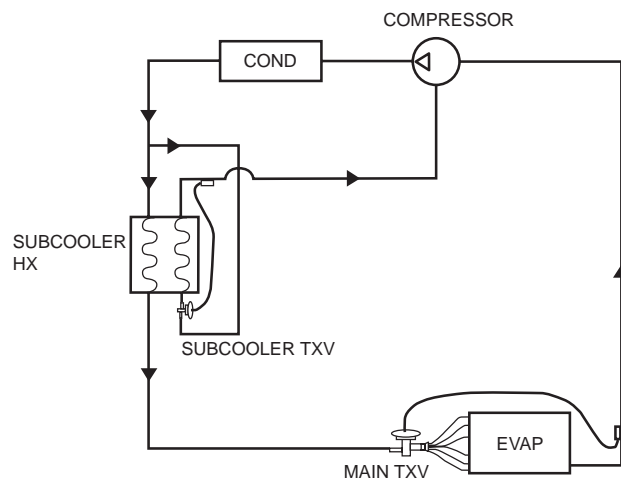

Fig. 29 — Subcooler Operation

Field-Installed Accessories

SPACE TEMPERATURE SENSOR (T-55) — The T-55 space temperature sensor (part no. 33ZCT55SPT) is a field-installed accessory. The sensor is installed on a building interior wall to measure room air temperature. The T-55 sensor also includes an override button on the front cover to permit occupants to override the Unoccupied Schedule (if programmed). The jumper wire in the installer's packet must be connected between R and W1 when using a T-55 device. See Fig. 30 and 31.

SPACE TEMPERATURE SENSOR (T-56) — The T-56 space temperature sensor (part no. 33ZCT56SPT) is a field-installed accessory. This sensor includes a sliding scale on the front cover that permits an occupant to adjust the space temperature set point remotely. The T-56 sensor also includes an override button on the front cover to allow occupants to override the unoccupied schedule (if programmed). The jumper wire in the installer's packet must be connected between R and W1 when using a T-56 device. See Fig. 30 and 32.

SPACE TEMPERATURE SENSOR (T-58) — The T-58 space temperature sensor (part no. 33ZCT58SPT) is a field-installed accessory. The T-58 sensor communicates with the *ComfortLink*[™] controller, providing space temperature, heating and cooling set points, and mode operation information. The jumper wire in the installer's packet must be connected between R and W1 when using a T-58 device. See Fig. 33.

Refer to the T-58 installation instructions for information on installing and configuring the T-58 sensor.

Each T-58 sensor must have a unique address on the CCN. Each T-58 sensor must also be configured with the address of the unit control it is communicating to.

SPACE TEMPERATURE SENSOR AVERAGING — See Fig. 34 for space temperature averaging with T-55 sensors only. If the use of one T-56 sensor is required, refer to Fig. 35.

ECONOMIZER — The economizer accessory usage depends on model size. When installing this accessory, the unit must be configured for economizer installation by setting **Configuration** → **ECON** → **EC.EN** to YES. The default settings for the other economizer configurations should be satisfactory. If they need to be changed, additional information about these configuration settings can be found in the Economizer section.

POWER EXHAUST — The power exhaust accessory usage depends on voltage. When installing this accessory, the unit must be configured for power exhaust installation by setting **Configuration** → **ECON** → **PE.EN** to ENBL. The default settings for the other power exhaust configurations should be satisfactory. If they need to be changed, additional information about these configurations can be found in the Power Exhaust section.

TWO-POSITION DAMPER — This accessory wires directly into the low voltage circuit for the indoor fan control. No other control configuration is needed.

INDOOR AIR QUALITY — The indoor air quality (IAQ) sensor is a field-installed accessory which measures CO₂ levels in the air. When installing this sensor, the unit must be configured for IAQ use by setting **Configuration** → **AIR.Q** → **IA.CF** to a value of 1, 2, or 3. See the Indoor Air Quality section for more information.

OUTDOOR AIR QUALITY — The outdoor air quality (OAQ) sensor (part no. 33ZCSENCO2) is a field-installed accessory that measures CO₂ levels in the air. When installing this sensor, the unit must be configured for OAQ use by setting **Configuration** → **AIR.Q** → **OA.CF** to a value of 1 or 2. See the Indoor Air Quality section for more information.

SMOKE DETECTORS — The smoke detectors are field-installed accessories. These detectors can detect smoke in either the return air (part no. CRSMKDET001D00) or supply and return air (part no. CRSMKSUP001B00). When installing either detector, the unit must be configured for fire shutdown by setting **Configuration** → **UNIT** → **FS.SW** to normally open (1) or normally closed (2).

NOTE: When a Humidi-Mizer[™] system is installed, the inputs to the fire shutdown are moved to the control harness. See the Third Party Control section on page 38 for more information.

FILTER STATUS — The filter status accessory (part no. CRSTATUS003B00) is a field-installed accessory. This accessory detects plugged filters. When installing this accessory, the unit must be configured for filter status by setting **Configuration** → **UNIT** → **FL.SW** to normally open (1) or normally closed (2). Normally open (1) is the preferred configuration.

FAN STATUS — The fan status accessory (part no. CRSTATUS003B00) is a field-installed accessory. This accessory detects when the indoor fan is blowing air. When installing this accessory, the unit must be configured for fan status by setting **Configuration** → **UNIT** → **FN.SW** to normally open (1) or normally closed (2). Normally open (1) is the preferred configuration.

ENTHALPY SENSORS — The enthalpy accessories (part no. CRENTSNG02A00 and CRENTDIF02A00) are field-installed accessories. The first accessory (outdoor air only) determines when the enthalpy is low relative to a fixed reference. Adding the second accessory (return air) compares the enthalpy between the outdoor and return airstreams. In each case, the enthalpy 4 to 20 mA signals are converted to a switch output which is read by the ECB. When installing this accessory, the unit must be configured for enthalpy-based control by setting **Configuration** → **ECON** → **EN.SW** to normally open (1). See Fig. 14-19 for wiring details.

RETURN/SUPPLY AIR TEMPERATURE SENSOR — The temperature sensor (part no. 33ZCSENSAT) is a field-installed accessory which may be installed on the common return air duct and/or the common supply air duct near the unit. The duct return air temperature (RAT) may be selected for display only if the space temperature offset (SPTO) is not used. When installing the sensor, the unit must be configured by setting **Configuration** → **UNIT** → **RAT.S** to YES. The duct supply air temperature (SAT) may be used to replace the SAT sensor that is internal to the unit. A supply duct SAT measurement is valid for heating mode display while the factory-standard internal SAT is not valid for heating due to its location upstream of the heating section. When installing the supply duct SAT, the unit must be configured by setting **Configuration** → **UNIT** → **SAT.H** to ENBL. A SAT sensor in the supply duct is the preferred configuration for systems with Carrier VVT[®] controls.

SPACE HUMIDITY SENSOR — The space relative humidity sensor (part no. HL39ZZ005 duct mount or HL39ZZ007 wall mount) is a field-installed accessory. The space relative humidity (RHS) may be selected for display only if the outdoor air quality sensor (OAQ) is not used. When installing the relative humidity sensor, the unit must be configured by setting **Configuration** → **UNIT** → **RH.S** to YES.

ELECTRIC HEAT — The electric heat accessory depends on model size, voltage, and heater kW size. When field installing this accessory, the unit must be configured for electric heat by setting **Configuration** → **HEAT** → **HT.TY** to a value of 2.

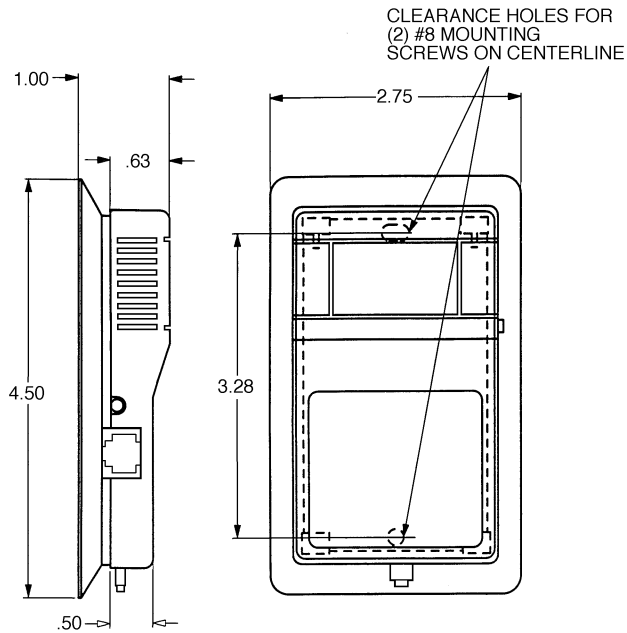

NOTE: Dimensions are in inches.

Fig. 30 — Space Temperature Sensor Mounting

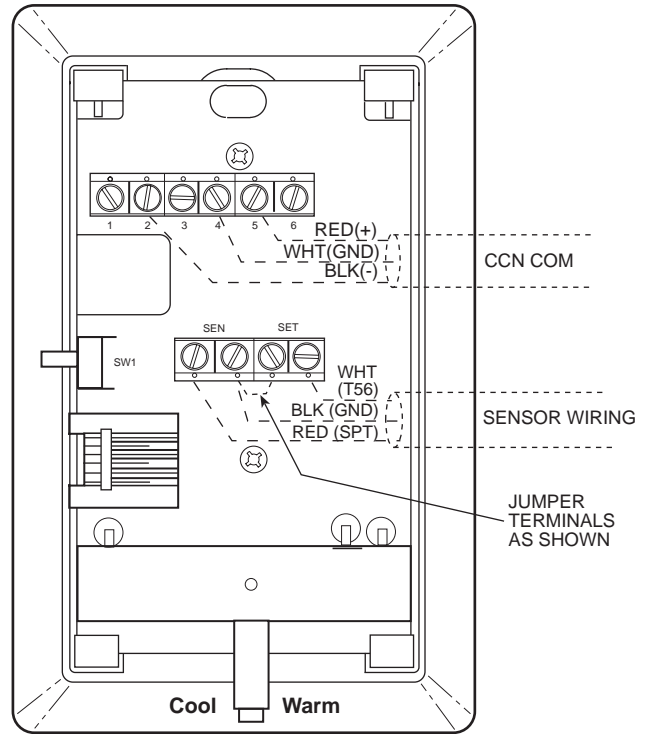

**Fig. 32 — T-56 Space Temperature Sensor Wiring
(P/N 33ZCT56SPT)**

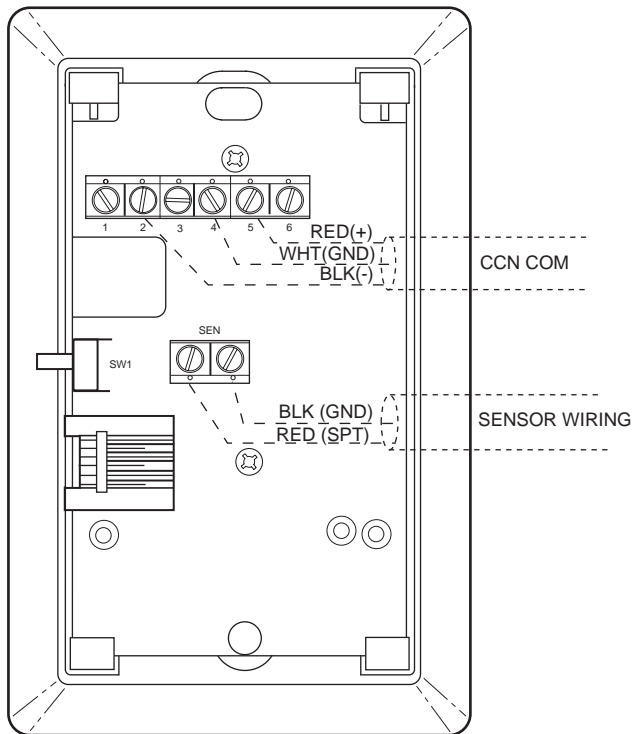

**Fig. 31 — T-55 Space Temperature Sensor Wiring
(P/N 33ZCT55SPT)**

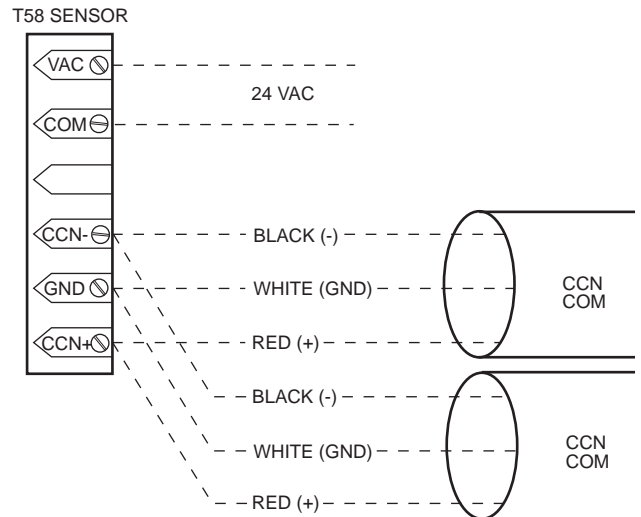

LEGEND

CCN — Carrier Comfort Network

**Fig. 33 — T-58 Communicating Space
Temperature Sensor Wiring**

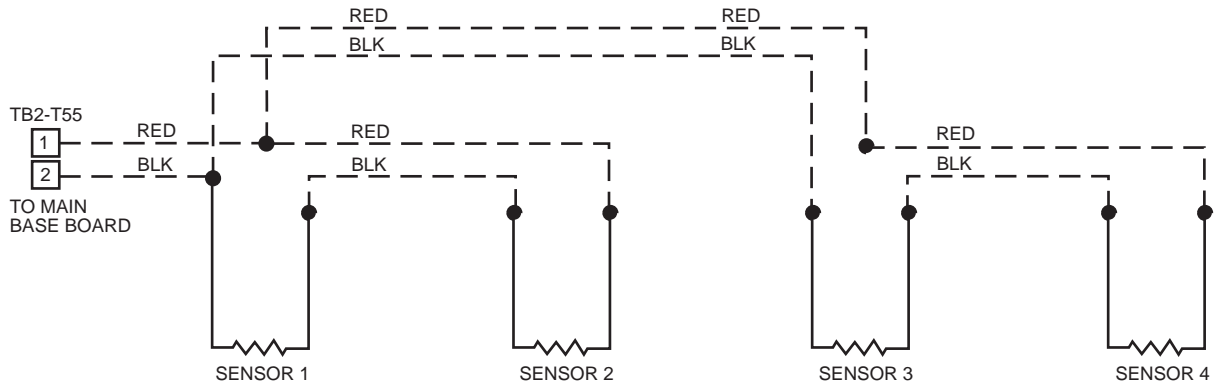

SPACE TEMPERATURE AVERAGING — 4 T-55 SENSOR APPLICATION

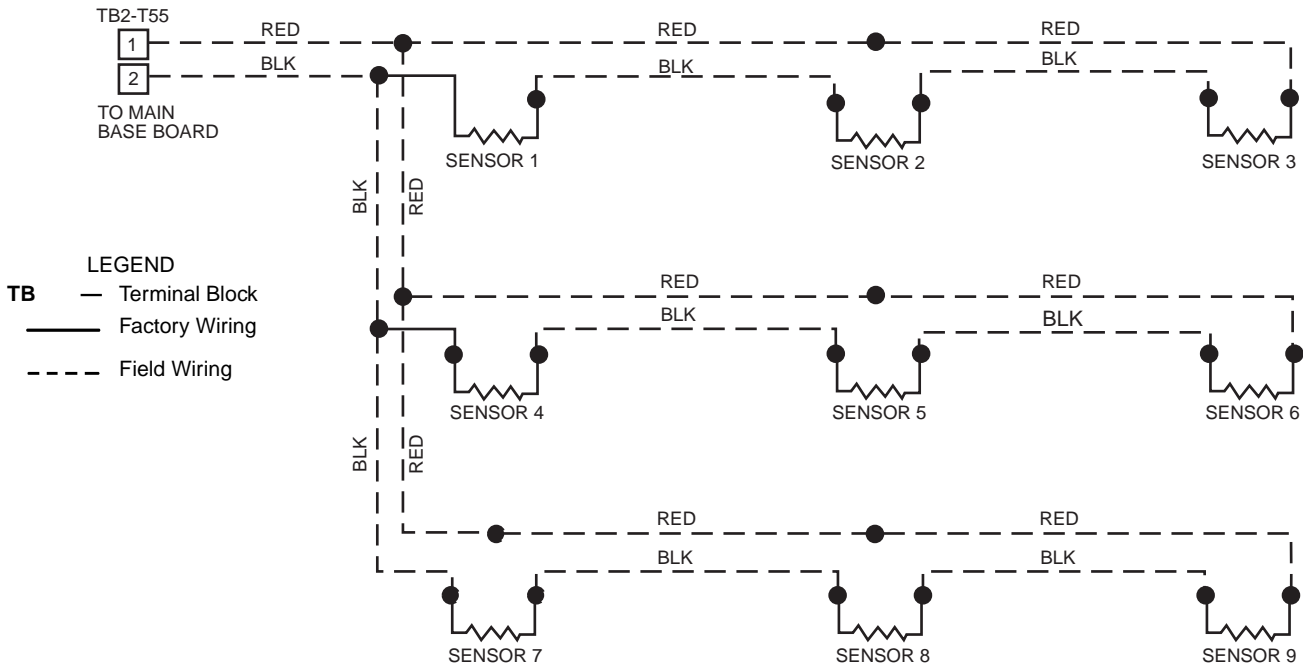

LEGEND

- TB** — Terminal Block
- Factory Wiring
- - - Field Wiring

SPACE TEMPERATURE AVERAGING — 9 T-55 SENSOR APPLICATION

Fig. 34 — Space Temperature Sensor Averaging

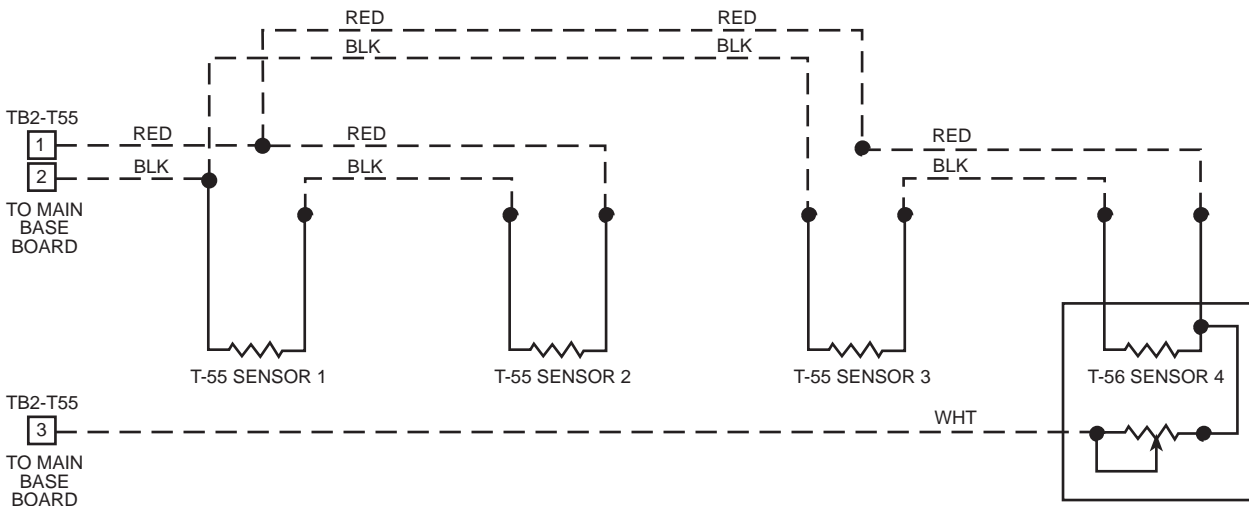

Fig. 35 — Space Temperature Sensor Averaging with 3 T-55 Sensors and One T-56 Sensor

SERVICE

⚠ WARNING

Before performing service or maintenance operations on unit, turn off main power switch to unit. Electrical shock could cause personal injury.

⚠ CAUTION

Puron® (R-410A) refrigerant systems operate at higher pressures than standard R-22 systems. Do not use R-22 service equipment or components on Puron refrigerant equipment. If service equipment is not rated for Puron refrigerant, equipment damage or personal injury may result.

⚠ WARNING

1. Improper installation, adjustment, alteration, service, or maintenance can cause property damage, personal injury, or loss of life. Refer to the User's Information Manual provided with this unit for more details.
2. Do not store or use gasoline or other flammable vapors and liquids in the vicinity of this or any other appliance.

What to do if you smell gas:

1. DO NOT try to light any appliance.
2. DO NOT touch any electrical switch, or use any phone in your building.
3. IMMEDIATELY call your gas supplier from a neighbor's phone. Follow the gas supplier's instructions.
4. If you cannot reach your gas supplier, call the fire department.

⚠ WARNING

Disconnect gas piping from unit when pressure testing at pressure greater than 0.5 psig. Pressures greater than 0.5 psig will cause gas valve damage resulting in hazardous condition. If gas valve is subjected to pressure greater than 0.5 psig, it *must* be replaced before use. When pressure testing field-supplied gas piping at pressures of 0.5 psig or less, a unit connected to such piping must be isolated by closing the manual gas valve(s).

Cleaning — Inspect unit interior at beginning of each heating and cooling season and as operating conditions require. Remove unit top panel and/or side panels for access to unit interior. **COIL MAINTENANCE AND CLEANING RECOMMENDATION** — Routine cleaning of coil surfaces is essential to maintain proper operation of the unit. Elimination of contamination and removal of harmful residues will greatly increase the life of the coil and extend the life of the unit. The following maintenance and cleaning procedures are recommended as part of the routine maintenance activities to extend the life of the coil.

Remove Surface Loaded Fibers — Surface loaded fibers or dirt should be removed with a vacuum cleaner. If a vacuum cleaner is not available, a soft non-metallic bristle brush may be used. In either case, the tool should be applied in the direction of the fins. Coil surfaces can be easily damaged (fin edges can be easily bent over and damage to the coating of a protected coil) if the tool is applied across the fins.

NOTE: Use of a water stream, such as a garden hose, against a surface loaded coil will drive the fibers and dirt into the coil.

This will make cleaning efforts more difficult. Surface loaded fibers must be completely removed prior to using low velocity clean water rinse.

Periodic Clean Water Rinse — A periodic clean water rinse is very beneficial for coils that are applied in coastal or industrial environments. However, it is very important that the water rinse is made with very low velocity water stream to avoid damaging the fin edges. Monthly cleaning as described below is recommended.

Routine Cleaning of Coil Surfaces — Monthly cleaning with Totaline® environmentally sound coil cleaner is essential to extend the life of coils. This cleaner is available from Carrier Replacement parts division as part number P902-0301 for a one gallon container, and part number P902-0305 for a 5 gallon container. It is recommended that all coils, including standard aluminum, pre-coated, copper/copper or E-coated coils be cleaned with the Totaline environmentally sound coil cleaner as described below. Coil cleaning should be part of the unit's regularly scheduled maintenance procedures to ensure long life of the coil. Failure to clean the coils may result in reduced durability in the environment.

Avoid the use of:

- coil brighteners
- acid cleaning prior to painting
- high pressure washers
- poor quality water for cleaning

Totaline environmentally sound coil cleaner is non-flammable, hypoallergenic, nonbacterial, and a USDA accepted biodegradable agent that will not harm the coil or surrounding components such as electrical wiring, painted metal surfaces, or insulation. Use of non-recommended coil cleaners is strongly discouraged since coil and unit durability could be affected.

Totaline Environmentally Sound Coil Cleaner Application Equipment

- 2½ gallon garden sprayer
- water rinse with low velocity spray nozzle

⚠ CAUTION

Harsh chemicals, household bleach or acid or basic cleaners should not be used to clean outdoor or indoor coils of any kind. These cleaners can be very difficult to rinse out of the coil and can accelerate corrosion at the fin/tube interface where dissimilar materials are in contact. If there is dirt below the surface of the coil, use the Totaline® environmentally sound coil cleaner as described above.

⚠ CAUTION

High velocity water from a pressure washer, garden hose, or compressed air should never be used to clean a coil. The force of the water or air jet will bend the fin edges and increase airside pressure drop. Reduced unit performance or nuisance unit shutdown may occur.

Totaline Environmentally Sound Coil Cleaner Application Instructions

1. Proper eye protection such as safety glasses is recommended during mixing and application.
2. Remove all surface loaded fibers and dirt with a vacuum cleaner as described above.
3. Thoroughly wet finned surfaces with clean water and a low velocity garden hose, being careful not to bend fins.
4. Mix Totaline environmentally sound coil cleaner in a 2½ gallon garden sprayer according to the instructions included with the cleaner. The optimum solution temperature is 100 F.

NOTE: Do **NOT USE** water in excess of 130 F, as the enzymatic activity will be destroyed.

5. Thoroughly apply Totaline environmentally sound coil cleaner solution to all coil surfaces including finned area, tube sheets and coil headers.
6. Hold garden sprayer nozzle close to finned areas and apply cleaner with a vertical, up-and-down motion. Avoid spraying in horizontal pattern to minimize potential for fin damage.
7. Ensure cleaner thoroughly penetrates deep into finned areas.
8. Interior and exterior finned areas must be thoroughly cleaned.
9. Finned surfaces should remain wet with cleaning solution for 10 minutes.
10. Ensure surfaces are not allowed to dry before rinsing. Re-applying cleaner as needed to ensure 10-minute saturation is achieved.
11. Thoroughly rinse all surfaces with low velocity clean water using downward rinsing motion of water spray nozzle. Protect fins from damage from the spray nozzle.

CONDENSATE DRAIN — Check and clean each year at the start of the cooling season. An access panel is located above the condensate connection to allow easy clean out of the condensate pan. The first time the panel is removed, the insulation behind the access panel will need to be cut away. Carefully cut the insulation with a knife or blade on three sides so the insulation can be folded out of the way during cleaning. Be careful not to damage components behind the insulation while cutting. Once cleaning is completed, fold the insulation back into place and secure the access panel in the original position.

FILTERS — Clean or replace at start of each heating and cooling season, or more often if operating conditions require. Refer to unit installation instructions for type and size.

OUTDOOR-AIR INLET SCREENS — Clean screens with steam or hot water and a mild detergent. Do not use throwaway filters in place of screens. See unit installation instructions for quantity and size.

MAIN BURNER (48PG Only) — At the beginning of each heating season, inspect for deterioration or blockage due to corrosion or other causes. Observe the main burner flames. Refer to Main Burners section on page 91.

FLUE GAS PASSAGEWAYS (48PG Only) — The flue collector box and heat exchanger cells may be inspected by removing heat section access panel (Fig. 5), flue box cover, and main burner assembly (Fig. 36). Refer to Main Burners section on page 91 for burner removal sequence. If cleaning is required, clean tubes with a wire brush.

Use caution with ceramic heat exchanger baffles. When installing retaining clip, be sure the center leg of the clip extends inward toward baffle. See Fig. 37.

COMBUSTION-AIR BLOWER (48PG Only) — Clean periodically to assure proper airflow and heating efficiency. Inspect blower wheel every fall and periodically during heating season. For the first heating season, inspect blower wheel bimonthly to determine proper cleaning frequency.

To inspect blower wheel, remove heat section panel. Using an inspection mirror and flashlight, look into the flue exhaust duct to inspect the wheel. If cleaning is required, remove motor and wheel assembly by removing the screws holding the flue box cover to the flue box. See Fig. 36. Remove the screws holding the inducer housing to the inlet plate. The wheel can then be removed from the motor shaft and cleaned with a detergent or solvent. Replace the wheel onto the motor shaft in the correct position and reassemble the flue cover onto the flue box.

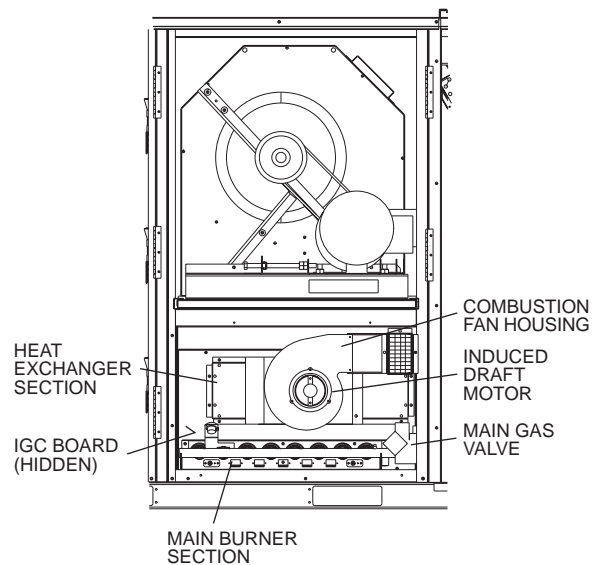

IGC — Integrated Gas Controller

Fig. 36 — Typical Gas Heating Section

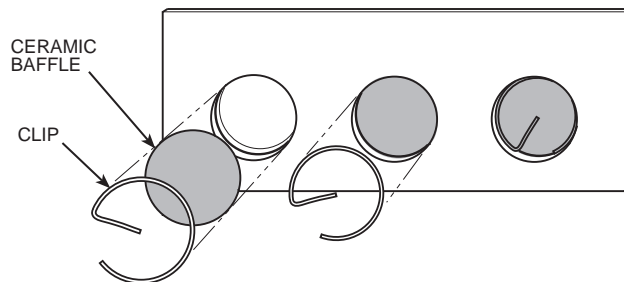

NOTE: One baffle and clip will be in each upper tube of the heat exchanger.

Fig. 37 — Removing Heat Exchanger Ceramic Baffles and Clips

Lubrication

COMPRESSORS — Each compressor is charged with the correct amount of oil at the factory.

⚠ CAUTION

The compressor is in a Puron® refrigerant system and uses a polyolester (POE) oil. This oil is extremely hygroscopic, meaning it absorbs water readily. POE oils can absorb 15 times as much water as other oils designed for HCFC and CFC refrigerants. Avoid exposure of the oil to the atmosphere. Damage to components could result.

Polyolester (POE) compressor lubricants are known to cause long term damage to some synthetic roofing materials. Exposure, even if immediately cleaned up, may cause roofing materials to become brittle (leading to cracking) within a year. When performing any service which may risk exposure of compressor oil to the roof, take appropriate precautions to protect roofing. Procedures which risk oil leakage include compressor replacement, repairing refrigerant leaks, and replacing refrigerant components. To prepare rooftop:

1. Cover extended roof work area with an impermeable plastic dropcloth or tarp. Make sure a 10 x 10 area around the work area is covered.

- Cover area in front of the unit service panel with a terry cloth shop towel to absorb lubricant spills and prevent run-offs. Towel will also protect dropcloth from tears caused by tools or components.
- Place terrycloth shop towel inside the unit directly under components to be serviced to prevent spills through the bottom of the unit.
- Perform the required service.
- Remove and dispose of any oil contaminated material per local codes.

FAN SHAFT BEARINGS — Lubricate bearings at least every 6 months with suitable bearing grease. Typical lubricants are given below:

| MANUFACTURER | LUBRICANT |
|--------------|--------------------|
| Texaco | Regal AFB-2* |
| Mobil | Mobilplex EP No. 1 |
| Sunoco | Prestige 42 |
| Texaco | Multifak 2 |

*Preferred lubricant because it contains rust and oxidation inhibitors.

FAN MOTOR BEARINGS — Fan motor bearings are of the permanently lubricated type. No field lubrication is required. No lubrication of the condenser or evaporator motors are required.

Manual Outdoor Air Damper — If manual outdoor air damper blade adjustment is required, refer to unit Installation Instructions.

Economizer Adjustment — If economizer adjustment is required, refer to unit Installation Instructions.

Evaporator Fan Service and Replacement — The 48/50PG units feature a slide-out fan deck for easy servicing of the indoor-fan motor, pulleys, belt, and bearings. To service components in this section, perform the following procedure:

- Turn off unit power.
- Open the fan section access panel.
- Remove three no. 10 screws at front of slide-out fan deck. Save screws. See Fig. 38.
- Disconnect the limit switch wires located on the right side of the fan deck (48PG only). Other wires do not need to be disconnected.
- Fan deck can now be slid out to access serviceable components.

CAUTION

DO NOT SLIDE FAN DECK OUT PAST THE STOP BRACKET. If further access is required, the fan deck must be supported. Make sure plugs and wiring are not pinched between fan housing and unit center post. Damage to unit may result.

- To replace fan deck to operating position, slide fan deck back into the unit. Secure with the three no. 10 screws removed in Step 3.
- Re-attach electrical plugs and wires.
- Close fan section access door.
- Restore power to unit.

Evaporator Fan Performance Adjustment (Fig. 38 and 39) — Fan motor pulleys are factory set for speed shown in Table 57.

To change fan speeds:

- Shut off unit power supply.
- Loosen nuts on the 4 carriage bolts in the mounting base. Using adjusting bolts and plate, slide motor and remove belt.
- Loosen movable-pulley flange setscrew (see Fig. 39).

- Screw movable flange toward fixed flange to increase speed and away from fixed flange to decrease speed. Increasing fan speed increases load on motor. Do not exceed maximum speed specified in unit Installation Instructions.

See Tables 27 and 28 for air quantity limits.

- Set movable flange at nearest keyway of pulley hub and tighten setscrew. (See Tables 33 and 34 for speed change for each full turn of pulley flange.)
- Replace and tighten belts (see Evaporator Fan Belt Tension Adjustment section below).
- Restore power to unit.

To align fan and motor pulleys:

- Loosen fan pulley setscrews.
- Slide fan pulley along fan shaft.
- Make angular alignment by loosening motor from mounting plate.

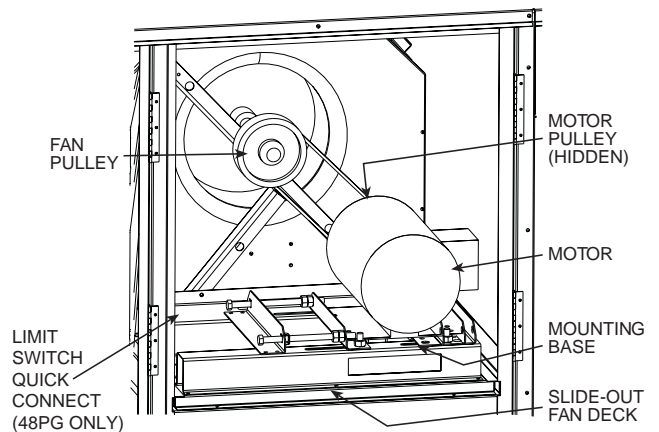

Fig. 38 — Evaporator-Fan Motor Adjustment

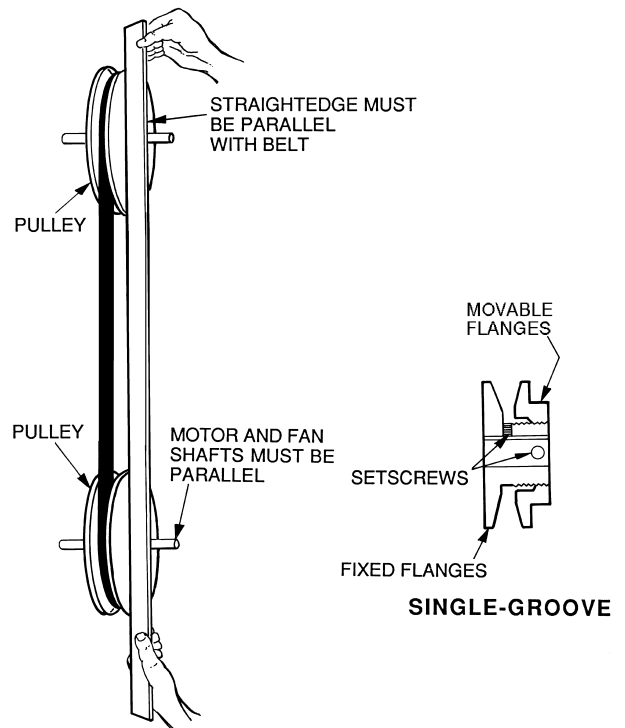

Fig. 39 — Evaporator-Fan Alignment and Adjustment

Evaporator Fan Belt Tension Adjustment — To adjust belt tension:

1. Turn off unit power.
2. Slide out fan deck to service position as shown in Evaporator Fan Service and Replacement section above.
3. Loosen fan motor bolts.
4. Move motor mounting plate to adjust to proper belt tension. See Table 57. Motor adjuster bolts may be used to tighten belts. See Fig. 38.
5. Check for proper belt alignment. Adjust if necessary.
6. Tighten motor mounting plate bolts to lock motor in proper position.
7. Return fan deck back into operating position.
8. Restore power to unit.

Condenser-Fan Adjustment (Fig. 40)

1. Shut off unit power supply.
2. Remove condenser-fan assembly (grille, motor, motor cover, and fan) and loosen fan hub setscrews.
3. Adjust fan height as shown in Fig. 40.
4. Tighten setscrews and replace condenser-fan assembly.
5. Turn on power to unit.

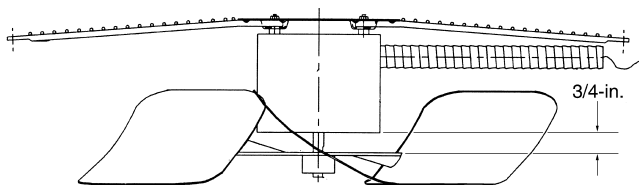

Fig. 40 — Condenser-Fan Adjustment

Verify Sensor Performance — Verify that thermistor, transducer, and switch inputs (see Tables 50-52) are reading correctly. These values can be accessed through the Scrolling Marquee display in the Temperatures, Pressures, and Inputs menus. Some values will depend on configuration choices. Refer to the Control Set Up Checklist completed for the specific unit installation and to the configuration tables in Appendix A.

Economizer Operation During Power Failure — Dampers have a spring return. In event of power failure, dampers will return to fully closed position until power is restored. *Do not manually operate damper motor.*

Evacuation — Proper evacuation of the system will remove noncondensables and ensure a tight, dry system before charging. Evacuate from both high and low side ports. Never use the system compressor as a vacuum pump. Refrigerant tubes and indoor coil should be evacuated to 500 microns. Always break a vacuum with dry nitrogen. The two possible methods are the deep vacuum method and the triple evacuation method.

DEEP VACUUM METHOD — The deep vacuum method requires a vacuum pump capable of pulling a minimum vacuum of 500 microns and a vacuum gage capable of accurately measuring this vacuum depth. The deep vacuum method is the most positive way of assuring a system is free of air and liquid water. (See Fig. 41.)

Table 57 — Belt Tension Adjustment

| 48PG | VOLTAGE | BELT TENSION (lb) | | | | | | | |
|------|---------|-------------------------------|-----|-----|-----|-----|-----|-----|-----|
| | | Unit Model Number Position 10 | | | | | | | |
| | | A,J | B,K | C,L | D,M | E,N | F,P | G,Q | H,R |
| 20 | 230 | 4.8 | 5.1 | 5.6 | 4.5 | NA | 4.7 | 5.0 | 5.5 |
| | 460 | 4.8 | 5.1 | 5.6 | 4.5 | NA | 4.7 | 5.0 | 5.5 |
| | 575 | 5.3 | 5.1 | 5.6 | 4.5 | NA | 5.2 | 5.0 | 5.5 |
| 24 | 230 | 4.8 | 5.1 | 5.6 | 4.5 | NA | 4.7 | 5.0 | 5.5 |
| | 460 | 4.8 | 5.1 | 5.6 | 4.5 | NA | 4.7 | 5.0 | 5.5 |
| | 575 | 5.3 | 5.1 | 5.6 | 4.5 | NA | 5.2 | 5.0 | 5.5 |
| 28 | 230 | 4.5 | 5.4 | 5.9 | 4.5 | 4.5 | 5.4 | 5.9 | 4.5 |
| | 460 | 4.5 | 5.4 | 5.9 | 4.5 | 4.5 | 5.4 | 5.9 | 4.5 |
| | 575 | 4.5 | 5.4 | 5.9 | 4.5 | 4.5 | 5.4 | 5.9 | 4.5 |

| 50PG | VOLTAGE | BELT TENSION (lb) | | | | | | | |
|------|---------|-------------------------------|-----|-----|-----|-----|-----|-----|-----|
| | | Unit Model Number Position 10 | | | | | | | |
| | | A,J | B,K | C,L | D,M | E,N | F,P | G,Q | H,R |
| 20 | 230 | 4.8 | 5.1 | 5.6 | 4.5 | 4.8 | 5.1 | 5.6 | 4.5 |
| | 460 | 4.8 | 5.1 | 5.6 | 4.5 | 4.8 | 5.1 | 5.6 | 4.5 |
| | 575 | 5.3 | 5.1 | 5.6 | 4.5 | 5.3 | 5.1 | 5.6 | 4.5 |
| 24 | 230 | 4.8 | 5.1 | 5.6 | 4.5 | 4.8 | 5.1 | 5.6 | 4.5 |
| | 460 | 4.8 | 5.1 | 5.6 | 4.5 | 4.8 | 5.1 | 5.6 | 4.5 |
| | 575 | 5.3 | 5.1 | 5.6 | 4.5 | 5.3 | 5.1 | 5.6 | 4.5 |
| 28 | 230 | 4.5 | 5.4 | 5.9 | 4.5 | 4.5 | 5.4 | 5.9 | 4.5 |
| | 460 | 4.5 | 5.4 | 5.9 | 4.5 | 4.5 | 5.4 | 5.9 | 4.5 |
| | 575 | 4.5 | 5.4 | 5.9 | 4.5 | 4.5 | 5.4 | 5.9 | 4.5 |

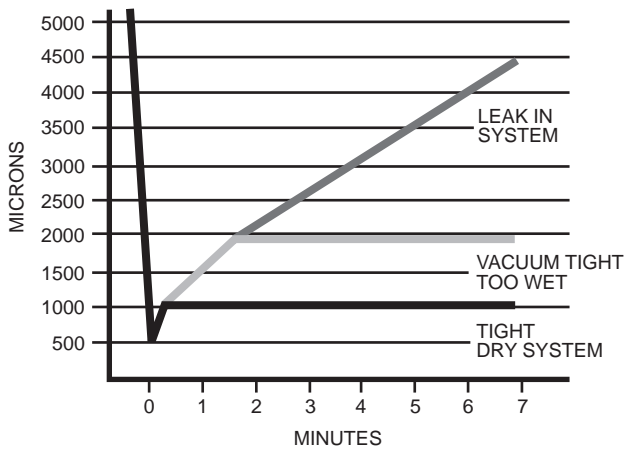

Fig. 41 — Deep Vacuum Graph

TRIPLE EVACUATION METHOD — The triple evacuation method should only be used when vacuum pump is capable of pumping down to 28 in. of mercury and system does not contain any liquid water. Proceed as follows:

1. Pump system down to 28 in. of mercury and allow pump to continue operating for an additional 15 minutes.
2. Close service valves and shut off vacuum pump.
3. Connect a nitrogen cylinder and regulator to system and open until system pressure is 2 psig.
4. Close service valve and allow system to stand for 1 hr. During this time, dry nitrogen will be able to diffuse throughout the system, absorbing moisture.
5. Repeat this procedure. System will then contain minimal amounts of contaminants and water vapor.

Refrigerant Charge — Amount of refrigerant charge is listed on unit nameplate. Refer to Carrier GTAC II; Module 5; Charging, Recovery, Recycling, and Reclamation section for charging methods and procedures. Unit panels must be in place when unit is operating during charging procedure.

Puron® (R-410A) refrigerant cylinders contain a dip tube which allows liquid refrigerant to flow from the cylinder in an upright position. Charge units with cylinder in the upright position and a commercial type metering device in the manifold hose.

⚠ CAUTION

This system uses Puron refrigerant which has higher pressures than R-22 and other refrigerants. No other refrigerant may be used in this system. Gage set, hoses, and recovery system must be designed to handle Puron refrigerant. If unsure about equipment, consult the equipment manufacturer.

NOTE: Do not use recycled refrigerant as it may contain contaminants.

NO CHARGE — Use standard evacuating techniques. After evacuating system, weigh in the specified amount of refrigerant (refer to unit nameplate).

NOTE: System charge for units with Humidi-MiZer™ system is greater than the system charge of the standard unit.

LOW CHARGE COOLING — Using cooling charging chart (see Fig. 42-45), add or remove refrigerant until conditions of the chart are met. An accurate pressure gage and temperature-sensing device are required. Charging is accomplished by ensuring the proper amount of liquid subcooling. Measure liquid line pressure at the liquid line service valve using pressure gage. Connect temperature sensing device to the liquid line near the liquid line service valve and insulate it so that outdoor ambient temperature does not affect reading.

TO USE THE COOLING CHARGING CHART, STANDARD UNITS — Use the above temperature and pressure readings, and find the intersection point on the cooling charging chart. If intersection point on chart is above line, add refrigerant. If intersection point on chart is below line, carefully recover some of the charge. Recheck suction pressure as charge is adjusted.

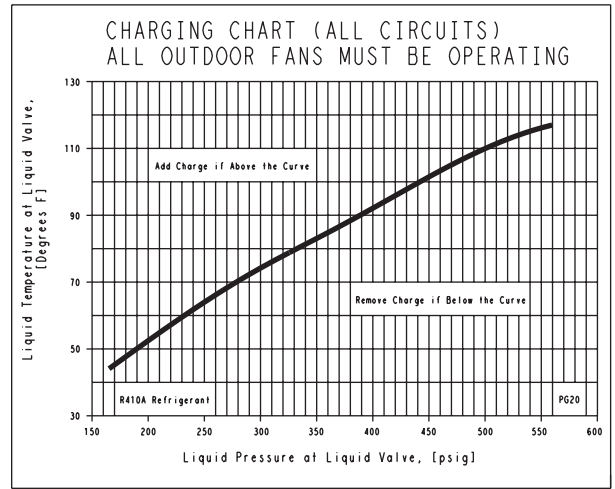

Fig. 42 — Charging Chart — 48/50PG20 — Standard Unit

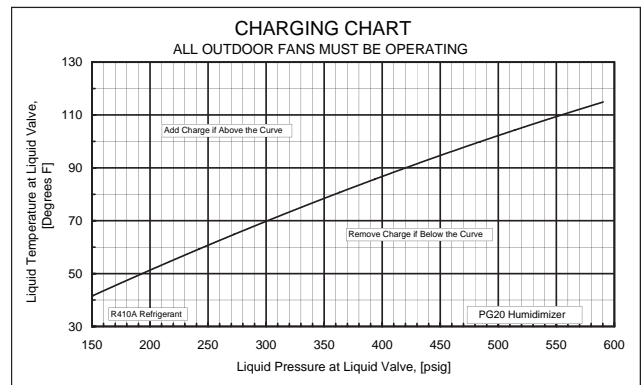

Fig. 43 — Charging Chart — 48/50PG20 — Unit with Humidi-MiZer™ System

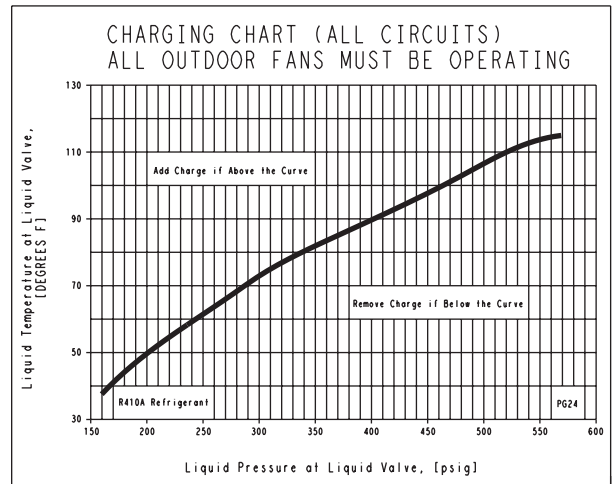

Fig. 44 — Charging Chart — 48/50PG24 — Standard Unit and Unit with Humidi-MiZer™ System

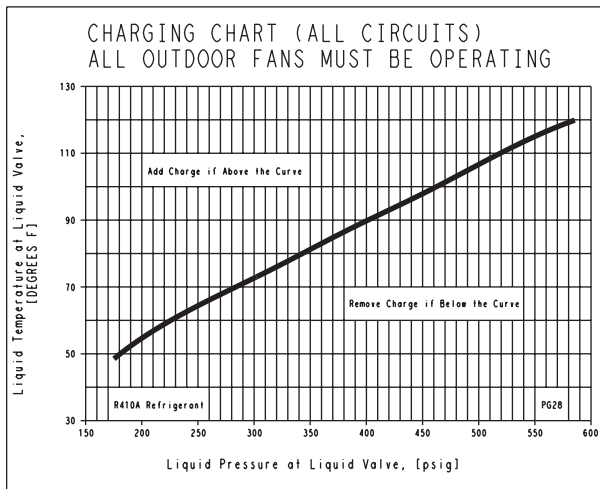

Fig. 45 — Charging Chart — 48/50PG28 — Standard Unit and Unit with Humidi-MiZer™ System

The TXV (thermostatic expansion valve) is set to maintain between 10 and 15 degrees of superheat at the compressors. The valves are factory set and cannot be adjusted. Do not use an R-22 TXV.

NOTE: All circuits must be running in normal cooling mode. Indoor airflow must be within specified air quantity limits for cooling (see Tables 27 and 28). All outdoor fans must be on and running at high speed. If outdoor temperature is low, this may require a temporary change in unit wiring.

TO USE THE COOLING CHARGING CHARTS, UNITS WITH HUMIDI-MIZER ADAPTIVE DEHUMIDIFICATION SYSTEM

NOTE: All circuits must be running in normal cooling mode. Indoor airflow must be within specified air quantity limits for cooling (see Tables 27 and 28). All outdoor fans must be on and running at high speed. Use the Cooling Service Test Outdoor Fan function (*Service Test* → *COOL* → *OF.OV*) to start all outdoor fans. If the outdoor temperature is low, the Motormaster® outdoor fan control device may need to be temporarily bypassed by rewiring the power leads to obtain full speed.

Be sure unit is in normal cooling mode by checking that the RH2 solenoid coil(s) and the CRC relay are deenergized (control outputs off). Adjust charge per the charging charts as described in the To Use The Cooling Charging Charts, Standard Unit section on page 89. Switch system to run in the dehumidification mode for 5 minutes. Dehumidification mode is when the RH2 solenoid coil(s) and the CRC relay are energized. Switch back to cooling mode to recheck pressures and temperatures on the charging chart and adjust charge if necessary. If charge adjustment is necessary, then repeat the steps in this paragraph until no charge adjustment is necessary. When no more charge adjustment is necessary after switching from Dehumidification mode back to Cooling mode, then charge adjustment procedure is complete. Remove jumper from the outdoor motor speed controller.

PURON® REFRIGERANT — Puron refrigerant operates at 50 to 70 percent higher pressures than R-22. Be sure that servicing equipment and replacement components are designed to operate with Puron refrigerant. Do not mix with components that have been used with other refrigerants. Puron refrigerant, as with other HFCs, is only compatible with POE oils.

Recovery cylinder service pressure rating must be 400 psig. Puron systems should be charged with liquid refrigerant. Use a commercial-type metering device in the manifold hose. Manifold sets should be 750 psig high-side and 200 psig low-side with 520 psig low-side retard. Use hoses with 750 psig service pressure rating. Leak detectors should be designed to detect HFC refrigerant.

Gas Valve Adjustment (48PG Only)

NATURAL GAS — The gas valve opens and closes in response to the thermostat or limit control.

When power is supplied to valve terminals W2 (High Fire) and C1, the main valve opens to its preset position.

The regular factory setting is stamped on the valve body. The setting is 3.00 in. wg for vertical supply/discharge units. The setting is 2.95 in. wg for horizontal supply/discharge units.

To adjust regulator:

1. Set unit at setting for no call for heat.
2. Turn main gas valve to OFF position.
3. Remove 1/8-in. pipe plug from manifold or gas valve pressure tap connection. Install a suitable pressure-measuring device.
4. Set main gas valve to ON position.
5. Set thermostat at setting to call for heat.
6. Remove screw cap covering regulator adjustment screw (See Fig. 46).
7. Turn adjustment screw clockwise to increase pressure or counterclockwise to decrease pressure.
8. Once desired pressure is established, set unit setting for no call for heat, turn off main gas valve, remove pressure-measuring device, and replace 1/8-in. pipe plug and screw cap.

High Altitude (48PG Only) — For high altitude applications greater than 2000 ft the heat input rate should be reduced. The higher the altitude is above sea level, the less oxygen is in the air. See Table 58 for orifice sizing. A high altitude kit is available to convert unit for altitudes up to 7,000 ft.

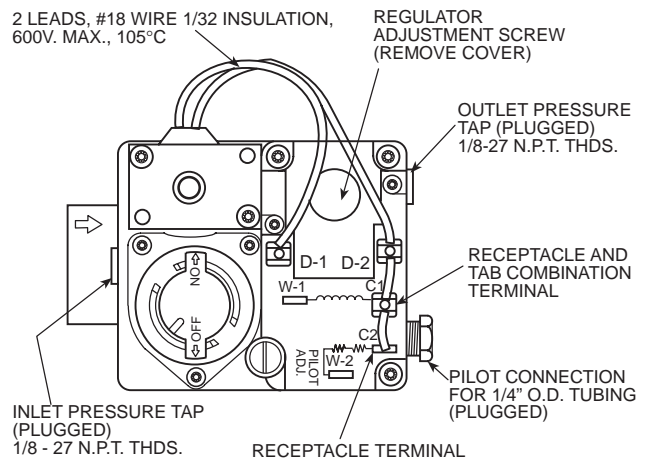

Fig. 46 — Gas Valve (48PG Only)

Main Burners (48PG Only) — For all applications, main burners are factory set and should require no adjustment.

MAIN BURNER REMOVAL

1. Shut off (field-supplied) manual main gas valve.
2. Shut off power to unit.
3. Remove gas section access panel.
4. Disconnect gas piping from gas valve inlet.
5. Remove wires from gas valve.
6. Remove wires from rollout switch.
7. Remove sensor wire and ignitor cable from IGC board.
8. Remove 2 screws securing manifold bracket to basepan.
9. Remove 2 screws that hold the burner assembly to vestibule plate.

10. Lift burner/manifold assembly out of unit.

CLEANING AND ADJUSTMENT

1. Remove burner rack from unit as described in Main Burner Removal section above.
2. Inspect burners, and if dirty, remove burners from rack.
3. Using a soft brush, clean burners and crossover port as required.
4. Adjust spark gap. See Fig. 47.
5. Reinstall burners on rack.
6. Reinstall burner rack as described above.

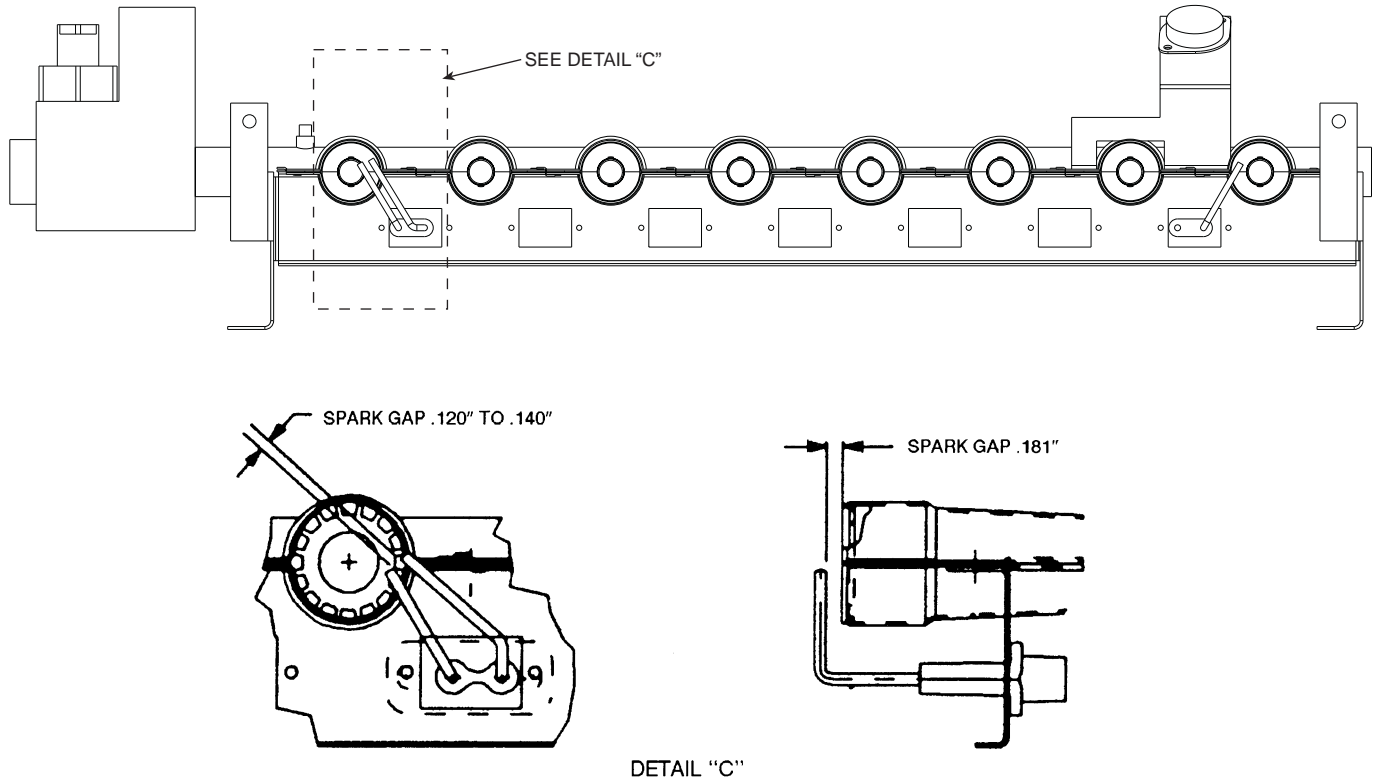

Fig. 47 — Spark Gap Adjustment (48PG Only)

Table 58 — Altitude Compensation* — 48PG20-28

| NATURAL GAS | | | |
|----------------|---------------------------|-------------------|-----------------|
| ELEVATION (ft) | NATURAL GAS ORIFICE SIZE† | | |
| | Low Heat (D,L) | Medium Heat (E,M) | High Heat (F,N) |
| 0-1,999 | 29 | 30 | 29 |
| 2,000 | 29 | 30 | 29 |
| 3,000 | 30 | 31 | 30 |
| 4,000 | 30 | 31 | 30 |
| 5,000 | 30 | 31 | 30 |
| 6,000 | 30 | 31 | 30 |
| 7,000 | 31 | 32 | 31 |
| 8,000 | 31 | 32 | 31 |
| 9,000 | 31 | 32 | 31 |
| 10,000 | 32 | 33 | 32 |

| PROPANE GAS | | | |
|----------------|---------------------------|-------------------|-----------------|
| ELEVATION (ft) | PROPANE GAS ORIFICE SIZE† | | |
| | Low Heat (D,L) | Medium Heat (E,M) | High Heat (F,N) |
| 0-1,999 | 35 | 38 | 35 |
| 2,000 | 36 | 39 | 36 |
| 3,000 | 36 | 39 | 36 |
| 4,000 | 37 | 40 | 37 |
| 5,000 | 37 | 40 | 37 |
| 6,000 | 38 | 41 | 38 |
| 7,000 | 39 | 42 | 39 |
| 8,000 | 40 | 43 | 40 |
| 9,000 | 41 | 44 | 41 |
| 10,000 | 42 | 45 | 42 |

*As the height above sea level increases, there is less oxygen per cubic foot of air. Therefore, heat input rate should be reduced at higher altitudes. Includes a 4% input reduction per each 1000 ft. †Orifices available through your Carrier dealer.

*As the height above sea level increases, there is less oxygen per cubic foot of air. Therefore, heat input rate should be reduced at higher altitudes. Includes a 4% input reduction per each 1000 ft. †Orifices available through your Carrier dealer.

Filter Drier — Replace whenever refrigerant system is exposed to atmosphere. Only use factory specified liquid-line filter driers with working pressures no less than 650 psig. Do not install a suction-line filter drier in liquid line. A liquid-line filter drier designed for use with Puron® refrigerant is required for each circuit.

Protective Devices

COMPRESSOR PROTECTION

Overcurrent — Each compressor has internal line break motor protection.

Overtemperature — Each compressor has an internal protector to protect it against excessively high discharge gas temperatures.

High-Pressure Switch — If the high-pressure switch trips, the compressor will shut down and the current sensor will not detect current. See the Current Sensor section below for more information.

Current Sensor (CS) — The purpose of the CS is to detect losses in compressor power. After detecting a loss in compressor power, unit control locks out the compressor for 15 minutes. After 15 minutes, the alarm will automatically reset. If this alarm occurs 3 times consecutively, the compressor will remain locked out until an alarm reset is initiated via CCN or manually via the Scrolling Marquee display (see Alarms and Alerts section on page 54 for more details).

EVAPORATOR FAN MOTOR PROTECTION — A manual reset, calibrated trip, magnetic circuit breaker protects against overcurrent. Do not bypass connections or increase the size of the breaker to correct trouble. Determine the cause and correct it before resetting the breaker.

CONDENSER-FAN MOTOR PROTECTION — Each condenser-fan motor is internally protected against overtemperature.

Fuses are also located in the control box and feed power to the condenser fan motors. Always replace blown fuses with the correct size fuse as indicated on the unit fuse label.

SATURATED SUCTION PRESSURE (SSP) — If the SSP for a particular circuit is reading below the alarm set point for an extended period of time, that circuit will be shut down. After 15 minutes, the alarm will automatically reset. If this alarm occurs 3 times consecutively, the circuit will remain locked out until an alarm reset is initiated via CCN or manually via the Scrolling Marquee display (see Alarms and Alerts section on page 54 for more details).

Relief Devices — All units have relief devices to protect against damage from excessive pressures (i.e., fire). These devices protect the high and low side and are located at the suction line service port. Protect joint during brazing operations near joint.

Control Circuit, 24-V — Each control circuit is protected against overcurrent by a 3.2 amp circuit breaker. Breaker can be reset. If it trips, determine cause of trouble before resetting.

Replacement Parts — A complete list of replacement parts may be obtained from any Carrier distributor upon request.

Diagnostic LEDs — The IGC control board has a LED for diagnostic purposes. See Heating Troubleshooting section on page 60 for more information.

**APPENDIX A — LOCAL DISPLAY AND CCN TABLES
MODE — RUN STATUS**

| ITEM | EXPANSION | RANGE | UNITS | CCN TABLE/ SUB-TABLE | CCN POINT | WRITE STATUS |
|--|---|--|--|---|--|--|
| RUN STATUS VIEW HVAC | Auto View of Run Status HVAC Mode Status | 1=Disabled 2=Fan Only 3=Cool 4=Heat | | STATUS DISPLAY (VIEW = Display only) | | |
| OCC SAT ALRM TIME | Currently Occupied Supply Air Temperature Current Alarms & Alerts Time of Day | Yes/No xxx.x xx xx.xx | dF hh.mm | | | |
| VERS MBB ECB MARQ | Software Version Numbers CESR131320-xx-xx CESR131249-xx-xx CESR131171-xx-xx | | | VERSIONS | | |
| HRS A1 A2 B1 C1 CCH IDF OFC.1 OFC.2 OFC.3 HT.1 HT.2 PE.1 PE.2 ALRM CRC RH2.A RH2.B | Component Run Hours Compressor A1 Run Hours Compressor A2 Run Hours Compressor B1 Run Hours Compressor C1 Run Hours Crankcase Heat Run Hours Indoor Fan Run Hours Outdoor Fan 1 Run Hours Outdoor Fan 2 Run Hours Outdoor Fan 3 Run Hours Heat Stage 1 Run Hours Heat Stage 2 Run Hours Power Exhaust1 Run Hours Power Exhaust2 Run Hours Alarm Relay Run Hours Reheat1 Valve Run Hours Reheat2 Valve A Run Hrs Reheat2 Valve BC Run Hrs | xxxxx.xx xxxxx.xx xxxxx.xx xxxxx.xx xxxxx.xx xxxxx.xx xxxxx.xx xxxxx.xx xxxxx.xx xxxxx.xx xxxxx.xx xxxxx.xx xxxxx.xx xxxxx.xx xxxxx.xx xxxxx.xx xxxxx.xx xxxxx.xx | hours hours hours hours hours hours hours hours hours hours hours hours hours hours hours hours hours hours | STRTHOUR | HR_A1 HR_A2 HR_B1 HR_C1 HR_CCH HR_IDF HR_OFC_1 HR_OFC_2 HR_OFC_3 HR_HTR_1 HR_HTR_2 HR_PE_1 HR_PE_2 HR_ALM HR_CRC HR_RH2_A HR_RH2_B | Forcible Forcible Forcible Forcible Forcible Forcible Forcible Forcible Forcible Forcible Forcible Forcible Forcible Forcible Forcible Forcible Forcible Forcible |
| STRT A1 A2 B1 C1 CCH IDF OFC.1 OFC.2 OFC.3 HT.1 HT.2 PE.1 PE.2 ALRM CRC RH2.A RH2.B | Component Starts Compressor A1 Starts Compressor A2 Starts Compressor B1 Starts Compressor C1 Starts Crankcase Heat Starts Indoor Fan Starts Outdoor Fan 1 Starts Outdoor Fan 2 Starts Outdoor Fan 3 Starts Heat Stage 1 Starts Heat Stage 2 Starts Power Exhaust1 Starts Power Exhaust2 Starts Alarm Relay Starts Reheat1 Valve Starts Reheat2 Valve A Starts Reheat2 Valve BC Starts | xxxxxx xxxxxx xxxxxx xxxxxx xxxxxx xxxxxx xxxxxx xxxxxx xxxxxx xxxxxx xxxxxx xxxxxx xxxxxx xxxxxx xxxxxx xxxxxx xxxxxx xxxxxx | | | ST_A1 ST_A2 ST_B1 ST_C1 ST_CCH ST_IDF ST_OFC_1 ST_OFC_2 ST_OFC_3 ST_HTR_1 ST_HTR_2 ST_PE_1 ST_PE_2 ST_ALM ST_CRC ST_RH2_A ST_RH2_B | Forcible Forcible Forcible Forcible Forcible Forcible Forcible Forcible Forcible Forcible Forcible Forcible Forcible Forcible Forcible Forcible Forcible Forcible |
| MODE SYS HVAC OCC T.OVR LINK C.LOC H.LOC E.LOC | Control Modes System Mode HVAC Mode Currently Occupied Timed Override in Effect Linkage Active Circuit OAT Lockout Heat OAT Lockout Econo Cool OAT Lockout | 1=Disabled 2=Enabled 3=Test 1=Off 2=Fan Only 3=Cool 4=Heat Yes/No Yes/No Yes/No Yes/No Yes/No | | MODEDISP | SYS_MODE HVACMODE OCCUPIED MODETOVR MODELINK COMPCLOCK HEATLOCK ECONLOCK | Forcible |
| COOL DMD.C AVL.C REQ.C IDF CCH OFC.1 OFC.2 OFC.3 CRC CIR.A CMP.A TG.A CS.A1 CS.A2 RH2.A SST.A SSP.A SCT.A SCP.A | Cooling Status Cooling Demand Available Cooling Stages Requested Cooling Stages Indoor Fan Relay Crankcase Heat Relay Outdoor Fan 1 Relay Outdoor Fan 2 Relay Outdoor Fan 3 Relay Cool->Reheat1 Control Refrigerant Circuit A Compressors A Timeguard A Compressor A1 Feedback Compressor A2 Feedback Reheat2 Valve A Sat. Suction Temp A Suction Pressure A Sat. Condenser Temp A Condenser Pressure A | xxx.x x x On/Off On/Off On/Off On/Off On/Off On/Off On/Off xxx xxx On/Off On/Off On/Off xxx.x xxx.x xxx.x xxx.x | ^F sec dF psig dF psig | COOLDISP | COOL_DMD AVLCSTGS REQCSTGS IDF CCH OFC_1 OFC_2 OFC_3 CRC COMP_A TIMGD_A CS_A1 CS_A2 RH2_A SST_A SSP_A SCT_A SCP_A | |

APPENDIX A — LOCAL DISPLAY AND CCN TABLES (cont)
MODE — RUN STATUS (cont)

| ITEM | EXPANSION | RANGE | UNITS | CCN TABLE/ SUB-TABLE | CCN POINT | WRITE STATUS |
|------------------------------|----------------------------|----------|-------|-------------------------|-----------|--------------|
| RUN STATUS (cont) | | | | | | |
| COOL (cont) | | | | | | |
| CIR.B | Refrigerant Circuit B | | | | | |
| CMP.B | Compressors B | On/Off | | | COMP_B | |
| TG.B | Timeguard B | xxx | sec | | TIMGD_B | |
| CS.B1 | Compressor B1 Feedback | On/Off | | | CS_B1 | |
| RH2.B | Reheat2 Valve B,C | On/Off | | | RH2_B | |
| SST.B | Sat. Suction Temp B | xxx.x | dF | | SST_B | |
| SSP.B | Suction Pressure B | xxx.x | psig | | SSP_B | |
| SCT.B | Sat. Condenser Temp B | xxx.x | dF | | SCT_B | |
| SCP.B | Condenser Pressure B | xxx.x | psig | | SCP_B | |
| CIR.C | Refrigerant Circuit C | | | | | |
| CMP.C | Compressors C | On/Off | | | COMP_C | |
| TG.C1 | Timeguard C | xxx | sec | | TIMGD_C | |
| CS.C1 | Compressor C1 Feedback | On/Off | | | CS_C1 | |
| RH2.C | Reheat2 Valve B,C | On/Off | | | RH2_C | |
| SST.C | Sat. Suction Temp C | xxx.x | dF | | SST_C | |
| SSP.C | Suction Pressure C | xxx.x | psig | | SSP_C | |
| SCT.C | Sat. Condenser Temp C | xxx.x | dF | | SCT_C | |
| SCP.C | Condenser Pressure C | xxx.x | psig | | SCP_C | |
| HEAT | Heating Status | | | HEATDISP | | |
| DMD.H | Heating Demand | xxx.x | ^F | | HEAT_DMD | |
| AVL.H | Available Heating Stages | x | | | AVLHSTGS | |
| REQ.H | Requested Heating Stages | x | | | REQHSTGS | |
| IDF | Indoor Fan Relay | On/Off | | | IDF | |
| HT.1 | Heat Stage 1 Relay | On/Off | | | HEAT_1 | |
| TG.H1 | Heat Stage 1 Timeguard | xxx | sec | | TIMGD_H1 | |
| HT.2 | Heat Stage 2 Relay | On/Off | | | HEAT_2 | |
| TG.H2 | Heat Stage 2 Timeguard | xxx | sec | | TIMGD_H2 | |
| ECON | Economizer Status | | | ECONDISP | | |
| EC.CP | Econo Commanded Position | xxx | % | | ECONOCMD | |
| EC.AP | Econo Actual Position | xxx | % | | ECONOPOS | |
| EC.MP | Minimum Position in Effect | xxx | % | | MIN_POS | |
| IAQ.S | IAQ Level (Switch) | High/Low | | | IAQIN | |
| IAQ | IAQ Level (Sensor) | xxxx | ppm | | IAQ | |
| OAT | Outdoor Air Temperature | xxx.x | dF | | OA_TEMP | |
| ENTH | Outdoor Enthalpy Switch | High/Low | | | ENTHALPY | |
| OAQ | OAQ Level (Sensor) | xxxx | ppm | | OAQ | |
| PE.1 | Power Exhaust 1 Relay | On/Off | | | PE_1 | |
| PE.2 | Power Exhaust 2 Relay | On/Off | | | PE_2 | |
| (LON_DATA = CCN only) | LON Communication Status | | | LON_DATA | | |
| | nviSpaceTemp | xxx.x | dF | | NVI_SPT | |
| | nviSetPoint | xxx.x | dF | | NVI_SP | Forcible |
| | nvoSpaceTemp | xxx.x | dF | | NVO_SPT | |
| | nvoUnitStatus.mode | xxxx | | | NVO_MODE | |
| | nvoUnitStatus.heat_out_p | xxx.x | % | | NVO_HPRI | |
| | nvoUnitStatus.heat_out_s | xxx.x | % | | NVO_HSEC | |
| | nvoUnitStatus.cool_out | xxx.x | % | | NVO_COOL | |
| | nvoUnitStatus.econ_out | xxx.x | % | | NVO_ECON | |
| | nvoUnitStatus.fan_out | xxx | % | | NVO_FAN | |
| | nvoUnitStatus.in_alarm | xxx | | | NVO_ALRM | |
| | nviSetPtOffset | xxx.x | ^F | | NVI_SPTO | Forcible |
| | nviOutsideTemp | xxx.x | dF | | NVI_OAT | Forcible |
| | nviOutsideRH | xxxx.x | % | | NVI_OARH | Forcible |
| | nvoEffectSetPt | xxx.x | dF | | NVO_EFSP | |
| | nvoOutsideTemp | xxxx.x | dF | | NVO_OAT | |
| | nvoOutsideRH | xxx.x | % | | NVO_OARH | |
| | nviSpaceRH | xxx.x | % | | NVI_SPRH | Forcible |
| | nviCO2 | xxxxx | | | NVI_CO2 | Forcible |
| | nvoCO2 | xxxxx | | | NVO_CO2 | |
| | nvoTEMP1 | xxx.x | dF | | NVO_SAT | |
| | nvoTEMP2 | xxx.x | dF | | NVO_RAT | Forcible |
| | nviPCT1 | xxx.x | % | | NVI_RHSP | |
| | nvoPCT1 | xxx.x | % | | NVO_SPRH | |
| | nviDISCRETE1 | Off/On | | | NVI_FSD | |
| | nviDISCRETE2 | No/Yes | | | NVI_OCC | |
| | nviDISCRETE3 | Off/On | | | NVI_IAQD | |
| | nvoDISCRETE1 | Off/On | | | NVO_FSD | Forcible |
| | nvoDISCRETE2 | No/Yes | | | NVO_OCC | Forcible |
| | nvoDISCRETE3 | Off/On | | | NVO_IAQD | |
| | nciCO2Limit | xxxxx | | | NCL_CO2 | |
| | nciSetPnts.occupied_cool | xxx.x | dF | | NCL_OCSP | Forcible |
| | nciSetPnts.standby_cool | xxx.x | dF | | NCL_SCSP | Forcible |
| | nciSetPnts.unoccupd_cool | xxx.x | dF | | NCL_UCSP | Forcible |
| | nciSetPnts.occupied_heat | xxx.x | dF | | NCL_OHSP | Forcible |
| | nciSetPnts.standby_heat | xxx.x | dF | | NCL_SHSP | Forcible |
| | nciSetPnts.unoccupd_heat | xxx.x | dF | | NCL_UHSP | Forcible |

APPENDIX A — LOCAL DISPLAY AND CCN TABLES (cont)

MODE — SERVICE TEST

| ITEM | EXPANSION | RANGE | UNITS | DEFAULT | CCN TABLE/ SUB-TABLE | CCN POINT | WRITE STATUS |
|---|---|--|-------|--|-------------------------|--|--|
| SERVICE TEST TEST | Field Service Test Mode | On/Off | | Off | MAINTENANCE DISPLAY | (TEST = display only) | Forcible |
| INDP ECON E.CAL PE.1 PE.2 ALRM CCH | Test Independent Outputs Economizer Position Test Calibrate Economizer Power Exhaust 1 Test Power Exhaust 2 Test Alarm Relay Test Crankcase Heat Test | 0 to 100 On/Off On/Off On/Off On/Off On/Off | % | 0 Off Off Off Off Off | TESTINDP | S_ECONO S_ECOCAL S_PE_1 S_PE_2 S_ALMOUT S_CCH | Forcible Forcible Forcible Forcible Forcible Forcible |
| FANS IDF OFC.1 OFC.2 OFC.3 | Test Fans Indoor Fan Test Outdoor Fan 1 Test Outdoor Fan 2 Test Outdoor Fan 3 Test | On/Off On/Off On/Off On/Off | | Off Off Off Off | TESTFANS | S_IDF S_OFC_1 S_OFC_2 S_OFC_3 | Forcible Forcible Forcible Forcible |
| COOL CMP.A CMP.B CMP.C OF.OV | Test Cooling Cool A Test Cool B Test Cool C Test Outdoor Fan Override | On/Off On/Off On/Off On/Off | | Off Off Off Off | TESTCOOL | S_COMP_A S_COMP_B S_COMP_C S_OFC_3 | Forcible Forcible Forcible Forcible |
| HMZR RH1.A RH1.B RH1.C RH2.A RH2.B RH2.C CRC RHV.A RHV.B | Test Humidimizer Reheat1 A Test Reheat1 B Test Reheat1 C Test Reheat2 A Test Reheat2 B Test Reheat2 C Test Cool->Reheat1 Valve Test Reheat2 Valve A Test Reheat2 Valve B, C Test | On/Off On/Off On/Off On/Off On/Off On/Off On/Off On/Off On/Off On/Off | | Off Off Off Off Off Off Off Off Off Off | TESTHMZR | S_RH1_A S_RH1_B S_RH1_C S2_RH2_A S2_RH2_B S2_RH2_C S_CRC S_RH2_A S_RH2_B | Forcible Forcible Forcible Forcible Forcible Forcible Forcible Forcible Forcible Forcible |
| HEAT HT.1 HT.2 | Test Heating Heat Stage 1 Test Heat Stage 2 Test | On/Off On/Off | | Off Off | TESTHEAT | S_HEAT_1 S_HEAT_2 | Forcible Forcible |

MODE — TEMPERATURES

| ITEM | EXPANSION | RANGE | UNITS | CCN TABLE/ SUB-TABLE | CCN POINT | WRITE STATUS |
|---|--|--|----------------------------------|--------------------------|--|--|
| TEMPERATURES AIR.T SAT OAT SPT SPTO RAT | Air Temperatures Supply Air Temperature Outdoor Air Temperature Space Temperature Space Temperature Offset Return Air Temperature | | | STATUS DISPLAY UINPUT | SAT_DISP OA_TEMP SPACE_T SPTO RETURN_T | Forcible Forcible Forcible Forcible |
| REFT SST.A SCT.A SST.B SCT.B SST.C SCT.C | Refrigerant Temperatures Sat. Suction Temp A Sat. Condenser Temp A Sat. Suction Temp B Sat. Condenser Temp B Sat. Suction Temp C Sat. Condenser Temp C | xxx.x xxx.x xxx.x xxx.x xxx.x xxx.x | dF dF dF dF dF dF | | SST_A SCT_A SST_B SCT_B SST_C SCT_C | |

MODE — PRESSURES

| ITEM | EXPANSION | RANGE | UNITS | CCN TABLE/ SUB-TABLE | CCN POINT | WRITE STATUS |
|--|---|--|--|--------------------------|--|--------------|
| PRESSURES SSPA SCPA SSPB SCPB SSPC SCPC | Refrigerant Pressures Suction Pressure A Condenser Pressure A Suction Pressure B Condenser Pressure B Suction Pressure C Condenser Pressure C | xxx.x xxx.x xxx.x xxx.x xxx.x xxx.x | psig psig psig psig psig psig | STATUS DISPLAY UINPUT | SSP_A SCP_A SSP_B SCP_B SSP_C SCP_C | |

APPENDIX A — LOCAL DISPLAY AND CCN TABLES (cont)

MODE — SET POINTS

| DISPLAY MENU/ SUB-MENU/NAME | EXPANDED NAME | VALUES | UNITS | DEFAULT | CCN TABLE/ SUB-TABLE | CCN NAME |
|--------------------------------|--------------------------|-----------|-------|---------------------------------------|-------------------------|-------------|
| SETPOINTS | | | | | SETPOINT CONFIGURATION | |
| | | | | | SET_PNT | |
| <i>OCSP</i> | Occupied Cool Setpoint | 55 to 80 | dF | 78 | | OCSP |
| <i>UCSP</i> | Unoccupied Cool Setpoint | 75 to 95 | dF | 85 | | UCSP |
| <i>OHSP</i> | Occupied Heat Setpoint | 55 to 80 | dF | 68 | | OHSP |
| <i>UHSP</i> | Unoccupied Heat Setpoint | 40 to 80 | dF | 60 | | UHSP |
| <i>GAP</i> | Heat-Cool Setpoint Gap | 2 to 10 | dF | 5 | | HCS_P_GAP |
| <i>STO.R</i> | SPT Offset Range (+/-) | 1 to 5 | ^F | 5 | | SPTO_RNG |
| <i>RH.SP</i> | Space RH Setpoint | 30 to 95 | % | 50 | | SPRH_SP |
| <i>RH.DB</i> | Space RH Deadband | 2 to 20 | % | 5 | | SPRH_DB |
| <i>RH.HB</i> | Reheat Heat SP Deadband | -5 to 5 | ^F | 2 | | RH_HSPDB |
| <i>CA.LO</i> | Circuit A Lockout Temp | 0 to 100 | dF | 0 | | OATLCMPA |
| <i>CB.LO</i> | Circuit B Lockout Temp | 0 to 100 | dF | 0: no Humidi-Mizer 0: Humidi-Mizer | | OATLCMPB |
| <i>CC.LO</i> | Circuit C Lockout Temp | 0 to 100 | dF | 0 | | OATLCMPC |
| <i>HT.LO</i> | Heating Lockout Temp | 40 to 125 | dF | 75 | | OATLHEAT |
| <i>EH.LO</i> | Econo Cool Hi Temp Limit | 40 to 100 | dF | 65 | | OATLECLH |
| <i>EL.LO</i> | Econo Cool Lo Temp Limit | -30 to 50 | dF | 0 | | OATLECLL |
| <i>FC.LO</i> | Free Cool Low Temp Limit | -35 to 70 | dF | 50 | | OATLUEFC |
| <i>LCSP</i> | Low Cool SAT Setpoint | 55 to 75 | dF | 65 | | LCSASP |
| <i>HCSP</i> | High Cool SAT Setpoint | 50 to 70 | dF | 55 | | HCSASP |
| <i>SAT.U</i> | Minimum SAT Upper Level | 35 to 65 | dF | 58 (20, 24) | | SATMIN_H |
| <i>SAT.L</i> | Minimum SAT Lower Level | 35 to 65 | dF | 53 (28) 48 | | SATMIN_L |

MODE — INPUTS

| ITEM | EXPANSION | RANGE | UNITS | CCN TABLE/ SUB-TABLE | CCN POINT | WRITE STATUS |
|---------------|-------------------------|-------------|-------|-------------------------|--------------|-----------------|
| INPUTS | | | | STATUS DISPLAY | | |
| <i>STAT</i> | Thermostat Inputs | | | UINPUT | | |
| <i>Y1</i> | Thermostat Y1 Input | On/Off | | | Y1 | Forcible |
| <i>Y2</i> | Thermostat Y2 Input | On/Off | | | Y2 | Forcible |
| <i>W1</i> | Thermostat W1 Input | On/Off | | | W1 | Forcible |
| <i>W2</i> | Thermostat W2 Input | On/Off | | | W2 | Forcible |
| <i>G</i> | Thermostat G Input | On/Off | | | G | Forcible |
| <i>GEN.I</i> | General Inputs | | | | | |
| <i>FIL.S</i> | Filter Status Switch | Dirty/Clean | | | FILTSTAT | |
| <i>FAN.S</i> | Fan Status Switch | On/Off | | | FAN_STAT | |
| <i>FDWN</i> | Fire Shutdown Switch | On/Off | | | FIREDOWN | Forcible |
| <i>ENTH</i> | Outdoor Enthalpy Switch | High/Low | | | ENTHALPY | Forcible |
| <i>RM.OCC</i> | Remote Occupancy Switch | On/Off | | | REM_OCC | Forcible |
| <i>HUM</i> | Space Humidity Switch | High/Low | | | HUM_STAT | Forcible |
| <i>CS.IN</i> | Current Sensor Inputs | | | | | |
| <i>CS.A1</i> | Compressor A1 Feedback | On/Off | | | CS_A1 | |
| <i>CS.A2</i> | Compressor A2 Feedback | On/Off | | | CS_A2 | |
| <i>CS.B1</i> | Compressor B1 Feedback | On/Off | | | CS_B1 | |
| <i>CS.C1</i> | Compressor C1 Feedback | On/Off | | | CS_C1 | |
| <i>AIR.Q</i> | Air Quality Inputs | | | | | |
| <i>IAQ.S</i> | IAQ Level (Switch) | High/Low | | | IAQIN | Forcible |
| <i>IAQ</i> | IAQ Level (Sensor) | xxxx | ppm | | IAQ | Forcible |
| <i>OAQ</i> | OAQ Level (Sensor) | xxxx | ppm | | OAQ | Forcible |
| <i>SP.RH</i> | Space Humidity Sensor | xxx.x | % | | SPRH | Forcible |

MODE — OUTPUTS

| ITEM | EXPANSION | RANGE | UNITS | CCN TABLE/ SUB-TABLE | CCN POINT | WRITE STATUS |
|----------------|--------------------------|----------|-------|-------------------------|--------------|-----------------|
| OUTPUTS | | | | STATUS DISPLAY | | |
| <i>FANS</i> | Fan Outputs | | | UOUTPUT | | |
| <i>IDF</i> | Indoor Fan Relay | On/Off | | | IDF | |
| <i>OFC.1</i> | Outdoor Fan 1 Relay | On/Off | | | OFC_1 | |
| <i>OFC.2</i> | Outdoor Fan 2 Relay | On/Off | | | OFC_2 | |
| <i>OFC.3</i> | Outdoor Fan 3 Relay | On/Off | | | OFC_3 | |
| <i>COOL</i> | Cool Outputs | | | | | |
| <i>CMP.A</i> | Circuit A Compressors | On/Off | | | COMP_A | |
| <i>CMP.B</i> | Circuit B Compressors | On/Off | | | COMP_B | |
| <i>CMP.C</i> | Circuit C Compressors | On/Off | | | COMP_C | |
| <i>CCH</i> | Crankcase Heat Relay | On/Off | | | CCH | |
| <i>CRC</i> | Cool->Reheat1 Control | On/Off | | | CRC | |
| <i>RH2.A</i> | Reheat2 Valve A | On/Off | | | RH2_A | |
| <i>RH2.B</i> | Reheat2 Valve BC | On/Off | | | RH2_B | |
| <i>HEAT</i> | Heat Outputs | | | | | |
| <i>HT.1</i> | Heat Stage 1 Relay | On/Off | | | HEAT_1 | |
| <i>HT.2</i> | Heat Stage 2 Relay | On/Off | | | HEAT_2 | |
| <i>ECON</i> | Economizer Outputs | | | | | |
| <i>EC.CP</i> | Econo Commanded Position | 0 to 100 | % | | ECONOCMD | Forcible |
| <i>EC.AP</i> | Econo Actual Position | 0 to 100 | % | | ECONOPOS | |
| <i>PE.1</i> | Power Exhaust 1 Relay | On/Off | | | PE_1 | Forcible |
| <i>PE.2</i> | Power Exhaust 2 Relay | On/Off | | | PE_2 | Forcible |
| <i>ALRM</i> | Alarm Relay | On/Off | | | ALMOUT | Forcible |

APPENDIX A — LOCAL DISPLAY AND CCN TABLES (cont)
MODE — CONFIGURATION

| ITEM | EXPANSION | RANGE | UNITS | DEFAULT | CCN TABLE/SUB-TABLE | CCN POINT | PAGE NO. |
|----------------------|---------------------------|---|-------|---|-----------------------|-----------|-----------------------|
| CONFIGURATION | | | | | SERVICE CONFIGURATION | | |
| DISP | Display Configuration | | | | DISPLAY | | |
| METR | Metric Display | On/Off | | Off | | DISPUNIT | 39 |
| LANG | Language Selection | 0=English 1=Spanish 2=French 3=Portuguese | | 0 | | LANGUAGE | 39 |
| PROT | Password Enable | Enable/Disable | | Enable | | PASS_EBL | 39 |
| PSWD | Service Password | 0000 to 9999 | | 1111 | | PASSWORD | 39 |
| TEST | Test Display LEDs | On/Off | | Off | | DISPTST | 39 |
| UNIT | Unit Configuration | | | | UNIT | | |
| S.DLY | Start Up Delay | 0 to 600 | sec | 30 | | STARTDLY | 39 |
| U.CTL | Unit Control Type | 1=Auto Select 2=Thermostat 3=Space Sensor | | 2 | | CTL_TYPE | 35, 39, 41, 43, 47 |
| T.CTL | Thermostat Control Type | 0=Adaptive 1=1 Stage Y1 2=2 Stage Y1 | | 0 | | STATTYPE | 38, 39, 41 |
| OC.FN | Fan On When Occupied | Yes/No | | Yes | | OCC_FAN | 39, 41, 43 |
| IDF.F | Shut Down on IDF Failure | Yes/No | | Yes | | FATALFAN | 40, 56 |
| EC.EN | Economizer Installed | Yes/No | | No: no FIOP Yes: FIOP | | ECONO | 40, 41 |
| FN.SW | Fan Status Switch | 0=No Switch 1=Normally Open 2=Normally Closed | | 0: no FIOP 1: FIOP | | FANSTCFG | 40, 56, 82 |
| FL.SW | Filter Status Switch | 0=No Switch 1=Normally Open 2=Normally Closed | | 0: no FIOP 1: FIOP | | FILSTCFG | 40, 82 |
| FS.SW | Fire Shutdown Switch | 0=No Switch 1=Normally Open 2=Normally Closed | | 0: no FIOP 1: FIOP | | SHTDNCFG | 38, 40 |
| RM.SW | Remote Occupancy Switch | 0=No Switch 1=Normally Open 2=Normally Closed | | 0 | | REMOCCFG | 38, 40 |
| SAT.T | SAT Settling Time | 10 to 900 | sec | 240 | | SAT_SET | 40, 42 |
| SAT.H | SAT Heat Mode Sensing | Enable/Disable | | Disable | | SAT_HEAT | 40, 44 |
| RAT.S | RAT Sensor On SPTO Input | Yes/No | | No | | RAT_SPTO | 40, 82 |
| RH.S | RH Sensor ON OAQ Input | Yes/No | | No | | RH_OAQ | 35, 38, 40, 47, 82 |
| RH.SW | Space Humidity Switch | 0=No Switch 1=Normal Open 2=Normal Closed | | 0: no Humidi-MiZer FIOP 1: Humidi-MiZer FIOP | | HUMSTCFG | 35, 38, 40, 47, 82 |
| TCS.C | Temp Cmp Strt Cool Factr | 0 to 60 | mins | 0 | | TCSTCOOL | 40, 51 |
| TCS.H | Temp Cmp Strt Heat Factr | 0 to 60 | mins | 0 | | TCSTHEAT | 40, 41 |
| COOL | Cooling Configuration | | | | COOL_CFG | | |
| N.CIR | Number of Circuits | 1 to 3 | | 2 | | NUM_CIRC | 56 |
| N.A | Compressors on Circuit A | 1 to 2 | | 1 | | A_COMPS | 56 |
| MRT.C | Compressor Min On Time | 120 to 999 | sec | 180 | | MIN_ON | 41, 42 |
| MOT.C | Compressor Min Off Time | 300 to 999 | sec | 300 | | MIN_OFF | 41, 42 |
| RST.C | Runtime to Reset Strikes | 120 to 999 | sec | 300 | | MIN_ON_S | 41, 42 |
| C.DEC | Cool Stage Decrease Rate | 120 to 999 | sec | 300 | | STAGEDEC | 41, 42 |
| C.INC | Cool Stage Increase Rate | 120 to 999 | sec | 450 | | STAGEINC | 41, 42 |
| FOD.C | Fan-off Delay, Mech Cool | 0 to 600 | sec | 60 | | COOL_FOD | 41, 42 |
| CA.LO | Circuit A Lockout Temp | 0 to 100 | dF | 0 | | OATLCMPA | 41 |
| CB.LO | Circuit B Lockout Temp | 0 to 100 | dF | 0: no Humidi-MiZer FIOP Humidi-MiZer FIOP: | | OATLCMPB | 41 |
| CC.LO | Circuit C Lockout Temp | 0 to 100 | dF | 0 | | OATLCMPC | 41 |
| ALM.N | Alert Each Strike | Yes/No | | Yes | | ALM_NOW | 52 |
| SAT | Supply Air Temperature | | | | | | |
| SA.PD | SAT Cool Demand (+) Level | 0.5 to 10 | AF | 1 | | SAT_POS | |
| SA.ND | SAT Cool Demand (-) Level | -10 to -0.5 | AF | -1 | | SAT_NEG | |
| SAT.U | Minimum SAT Upper Level | 35.0 to 65.0 | dF | 58 | | SATMIN_H | |
| SAT.L | Minimum SAT Lower Level | 35.0 to 65.0 | dF | 48 | | SATMIN_L | |
| SPT | Space Temperature | | | | | | |
| CL.PD | SPT Cool Demand (+) Level | 0.5 to 5 | AF | 1 | | DEM_POS | |
| CL.ND | SPT Cool Demand (-) Level | -5 to -0.5 | AF | -1 | | DEM_NEG | |
| C.LAG | Cool Thermal Lag Factor | 0 to 5 | min | 1 | | COOL_LAG | |
| CIR.A | Circuit A | | | | | | |
| CS.A1 | A1 Current Sensing | Enable/Disable | | Disable (1-phase) Enable (3-phase) | | A1_SENSE | 42 55 |
| CS.A2 | A2 Current Sensing | Enable/Disable | | Disable | | A2_SENSE | |
| A1.FN | A Circuit Level 1 Fans | 0 to 7 | | 1: No Humidi-MiZer FIOP (20, 24) 5: No Humidi-MiZer FIOP (28) | | CIR_A_1 | |
| A2.FN | A Circuit Level 2 Fans | 0 to 7 | | 1: Humidi-MiZer FIOP No Humidi-MiZer FIOP 3 (20) 2 (24, 28) Humidi-MiZer FIOP 3 (20) | | CIR_A_2 | |
| A3.FN | A Circuit Level 3 Fans | 0 to 7 | | 2 (24, 28) No Humidi-MiZer FIOP 3 (20, 24) 7 (28) Humidi-MiZer FIOP 3 | | CIR_A_3 | |

LEGEND

FIOP — Factory-Installed Option

APPENDIX A — LOCAL DISPLAY AND CCN TABLES (cont)
MODE — CONFIGURATION (cont)

| ITEM | EXPANSION | RANGE | UNITS | DEFAULT | CCN TABLE/ SUB-TABLE | CCN POINT | PAGE NO. |
|-----------------------------|--------------------------|----------------|-------|-----------------------|----------------------|-----------|----------|
| CONFIGURATION (cont) | | | | | | | |
| COOL (cont) | | | | | | | |
| CIR.B | Circuit B | | | | | | 42 |
| CS.B1 | B1 Current Sensing | Enable/Disable | | Enable | | B1_SENSE | 55 |
| B1.FN | B Circuit Level 1 Fans | 0 to 7 | | No Humidi-MiZer FIOP | | CIR_B_1 | |
| | | | | 4 | | | |
| B2.FN | B Circuit Level 2 Fans | 0 to 7 | | Humidi-MiZer FIOP | | CIR_B_2 | |
| | | | | 1 | | | |
| | | | | No Humidi-MiZer FIOP | | | |
| | | | | 6 (20) | | | |
| | | | | 2 (24, 28) | | | |
| | | | | Humidi-MiZer FIOP | | | |
| | | | | 3 (20) | | | |
| B3.FN | B Circuit Level 3 Fans | 0 to 7 | | 2 (24, 28) | | CIR_B_3 | |
| | | | | No Humidi-MiZer FIOP | | | |
| | | | | 6 | | | |
| | | | | Humidi-MiZer FIOP | | | |
| | | | | 3 | | | |
| CIR.C | | | | | | | |
| CS.C1 | Circuit C | | | | | | 42 |
| C1.FN | C1 Current Sensing | Enable/Disable | | Disable | | C1_SENSE | 55 |
| | C Circuit Level 1 Fans | 0 to 7 | | 0 | | CIR_C_1 | |
| C2.FN | C Circuit Level 2 Fans | 0 to 7 | | 0 | | CIR_C_2 | |
| C3.FN | C Circuit Level 3 Fans | 0 to 7 | | 0 | | CIR_C_3 | |
| SST | | | | | | | |
| SST.O | Low Suction Control | | | | LOW SUCTION CONTROL | | |
| SST.1 | Suction OK Temperature | 10 to 50 | dF | 18 | | SSTOK | |
| SST.2 | Low Suction — Level 1 | 10 to 50 | dF | 20 | | SSTLEV1 | 55 |
| SST.3 | Low Suction — Level 2 | 5 to 50 | dF | 15 | | SSTLEV2 | 55 |
| | Low Suction — Level 3 | 0 to 50 | dF | 10 | | SSTLEV3 | 42 |
| OFC | | | | | | | |
| OFC.3 | Outdoor Fan Control | | | | OUTDOOR FAN CONTROL | | |
| 0.MXP | OFC3 Enable, CCH Disable | Yes/No | | Yes | | OFC3_CTL | 56 |
| 1.MXP | Fan Lev0 Max Pressure | 100 to 500 | psig | 200 | | LEV0MAXP | |
| 2.MNP | Fan Lev1 Max Pressure | 100 to 500 | psig | 450 | | LEV1MAXP | |
| 2.ON | Fan Lev2 Min Pressure | 100 to 500 | psig | 200 | | LEV2MNP | |
| | Fan Lev2 On Temperature | 0 to 100 | F | no Humidi-MiZer FIOP: | | LEV2ON | |
| | | | | 55 (20) | | | |
| | | | | 45 (24-28) | | | |
| | | | | Humidi-MiZer FIOP: | | | |
| | | | | 68 (20) | | | |
| | | | | 61 (24) | | | |
| | | | | 61 (28) | | | |
| 2.OFF | Fan Lev2 Off Temperature | 0 to 100 | F | no Humidi-MiZer FIOP: | | LEV2OFF | |
| | | | | 50 (20) | | | |
| | | | | 40 (24-28) | | | |
| | | | | Humidi-MiZer FIOP: | | | |
| | | | | 57 (20) | | | |
| | | | | 57 (24) | | | |
| | | | | 57 (28) | | | |
| 2.MXP | Fan Lev2 Max Pressure | 100 to 500 | psig | 400 | | LEV2MAXP | |
| 3.MNP | Fan Lev3 Min Pressure | 100 to 500 | psig | 250 | | LEV3MNP | |
| 3.ON | Fan Lev3 on Temperature | 0 to 100 | F | no Humidi-MiZer FIOP: | | LEV3ON | |
| | | | | 65 | | | |
| | | | | Humidi-MiZer FIOP: | | | |
| | | | | 88 (20) | | | |
| | | | | 68 (24) | | | |
| | | | | 68 (28) | | | |
| 3.OFF | Fan Lev3 Off Temperature | 0 to 100 | F | no Humidi-MiZer FIOP: | | LEV3OFF | |
| | | | | 55 | | | |
| | | | | Humidi-MiZer FIOP: | | | |
| | | | | 78 (20) | | | |
| | | | | 62 (24) | | | |
| | | | | 62 (28) | | | |

LEGEND

FIOP — Factory-Installed Option

APPENDIX A — LOCAL DISPLAY AND CCN TABLES (cont)
MODE — CONFIGURATION (cont)

| ITEM | EXPANSION | RANGE | UNITS | DEFAULT | CCN TABLE/SUB-TABLE | CCN POINT | PAGE NO. |
|-----------------------------|--|---|-------|--|---------------------|-----------|------------------|
| CONFIGURATION (cont) | | | | | | | |
| HMZR REHT | Humidimizer Config Humidimizer Equipped | Yes/No | | No: no Humidi-MiZer FIOp Yes: Humidi-MiZer FIOp | HMZR_CFG | REHEAT | 42, 47 47, 56 |
| R.DEC | Reheat2 Stage Decr. Time | 0 to 999 | secs | 60 | | RSTAGDEC | 47 |
| R.INC | Reheat2 Stage Incr. Time | 0 to 999 | secs | 300 | | RSTAGINC | 47 |
| RH.FN | Reheat Fan Control | Yes/No | | Yes | | RHFANCTL | 47, 56 |
| RFLV | Reheat2 ODF Fan On Level | 0 to 3 | | 2 | | RHFANLEV | 47 |
| R.FON | Reheat2 ODF Fan On Temp | 0 to 100 | F | 93 (20) 93 (24) 85 (28) | | RHFANON | 47 |
| R.FOF | Reheat2 ODF Fan Off Temp | 0 to 100 | F | 83 (20) 88 (24) 80 (28) | | RHFANOFF | 47 |
| RA.LO | Reheat2 OAT Limit A | 20 to 70 | F | 40 | | OATLRH_A | 47 |
| RA.LP | Reheat2 SSP Lo Limit A | 50 to 100 | psig | 80 | | RHSSPL_A | 47 |
| RA.HP | Reheat2 SSP Hi Limit A | 50 to 100 | psig | 90 | | RHSSPH_A | 47 |
| RB.LO | Reheat2 OAT Limit B, C | 20 to 70 | F | 50 | | OATLRH_B | 47 |
| RB.LP | Reheat2 SSP Lo Limit B, C | 50 to 100 | psig | 80 | | RHSSPL_B | 47 |
| RB.HP | Reheat2 SSP Hi Limit B, C | 50 to 100 | psig | 90 | | RHSSPH_B | 47 |
| HEAT HT.TY | Heating Configuration Type of Heat Installed | 0 = No Heat 1 = Gas 2 = Electric | | 0 (50 series with no electric heat) 1 (48 series) 2 (50 series with electric heat) | HEAT_CFG | HEATTYPE | 42, 44, 82 |
| N.HTR | Number of Heat Stages | 1 to 2 | | 1 (48 series 1-phase, 50 series <15kW) 2 (48 series 3-phase, 50 series >=15kW) | | NUM_HEAT | 44 |
| MRT.H | Heat Minimum On Time | 60 to 999 | sec | 120 | | HMIN_ON | 42, 44 |
| MOT.H | Heat Minimum Off Time | 60 to 999 | sec | 120 | | HMIN_OFF | 42, 44 |
| H.DEC | Heat Stage Decrease Rate | 120 to 999 | sec | 300 | | HSTAGDEC | 43, 44 |
| H.INC | Heat Stage Increase Rate | 120 to 999 | sec | 450 | | HSTAGINC | 43, 44 |
| FOD.E | Fan-off Delay, Elect Heat | 10 to 600 | sec | 30 | | ELEC_FOD | 44 |
| FOD.G | Fan-off Delay, Gas Heat | 45 to 600 | sec | 45 | | GAS_FOD | 43 |
| HT.LO | Heating Lockout Temp | 40 to 125 | dF | 75 | | OATLHEAT | 42 |
| SAT.H | SAT Heat Mode Sensing | Enable/Disable | | Disable | | SAT_HEAT | 44 |
| SPT | Space Temperature Sensor | | | | | | |
| HT.PD | SPT Heat Demand (+) Level | 0.5 to 5 | AF | 1 | | HDEM_POS | |
| HT.ND | SPT Heat Demand (-) Level | -5 to -0.5 | AF | -1 | | HDEM_NEG | |
| H.LAG | Heat Thermal Lag Factor | 0 to 5 | min | 1 | | HEAT_LAG | |
| ECON EC.EN | Economizer Configuration Economizer Installed | Yes/No | | No: no FIOp Yes: FIOp | ECON_CFG | ECONO | 44, 82 |
| E.CTL | Economizer Control Type | 1=Digital, Position Feedback 2=Digital, Command Feedback 3=Analog Control | | 1 | | ECON_CTL | 36, 45, 57 |
| EC.MN | Econo Minimum Position | 0 to 100 | % | 30 | | ECONOMIN | 44 |
| EC.MX | Econo Cool Max Position | 0 to 100 | % | 100 | | ECONOMAX | 44, 45 |
| EH.LO | Econo Cool Hi Temp Limit | 40 to 100 | dF | 65 | | OATLECLH | |
| EL.LO | Econo Cool Lo Temp Limit | -30 to 50 | dF | 0 | | OATLECLL | |
| UEFC | Unoccupied Free Cooling | 0=Disabled 1=Entire Unoccupied Period 2=PreOccupancy Time | | 2 | | UEFC_CFG | 45 |
| FC.TM | Free Cool PreOcc Time | 1 to 9999 | min | 120 | | UEFCTIME | 45 |
| FC.LO | Free Cool Low Temp Limit | 0 to 70 | dF | 50 | | OATLUEFC | 45 |
| PE.EN | Power Exhaust Installed | Yes/No | | No: no FIOp Yes: FIOp | | PE_ENABL | 45, 82 |
| PE.1 | PE Stage1 Econo Position | 10 to 100 | % | 40 | | PE1_POS | 45 |
| PE.2 | PE Stage2 Econo Position | 10 to 100 | % | 75 | | PE2_POS | 45 |
| EN.SW | Enthalpy Switch | 0=No Switch 1=Normally Open 2=Normally Closed | | 0: no FIOp 1: FIOp | | ENTHLCFG | 38 |
| E.TRV | Economizer Travel Time | 5 to 300 | sec | 150 | | ECONOTRV | |
| E.MXB | Bottom Stage Max Econo | 0 to 100 | % | 50 | | ECONMAXB | |
| E.MXM | Middle Stage Max Econo | 1 to 100 | % | 35 | | ECONMAXM | |
| E.MXT | Top Stage Max Econo | 0 to 100 | % | 25 | | ECONMAXT | |
| E.DBD | Economizer PID Deadband | 0 to 25 | % | 3 | | ECONBAND | |
| EC.P | Economizer PID — kP | 0.0 to 99.9 | sec | 2.5 | | ECONO_P | |
| EC.I | Economizer PID — kI | 0.0 to 99.9 | sec | 0.1 | | ECONO_I | |
| EC.D | Economizer PID — kD | 0.0 to 99.9 | sec | 1 | | ECONO_D | |
| EC.DT | Economizer PID — rate | 10.0 to 180.0 | sec | 15 | | ECONO_DT | |

LEGEND

FIOp — Factory-Installed Option

APPENDIX A — LOCAL DISPLAY AND CCN TABLES (cont)
MODE — CONFIGURATION (cont)

| ITEM | EXPANSION | RANGE | UNITS | DEFAULT | CCN TABLE/SUB-TABLE | CCN POINT | PAGE NO. |
|---|---|--|-------|---|---|---|--|
| CONFIGURATION (cont) | | | | | | | |
| AIR.Q IA.CF | Air Quality Configuration IAQ Analog Input Config | 0=No IAQ 1=Demand Ventilation 2=Econ Position Override 3=Econ Min Position Control | | 0: no FIOP 1: FIOP | IAQ_CFG | IAQANCFG | 39, 49, 82 |
| IA.FN | IAQ Analog Fan Config | 0=Never 1=Only While Occupied 2=Always | | 0 | | IAQANFAN | 41, 51 |
| II.CF | IAQ Switch Input Config | 0=No IAQ 1=DCV Normally Open 2=DCV Normally Closed 3=Override Normally Open 4=Override Normally Closed | | 0 | | IAQINCFG | 39, 49, 50 |
| II.FN | IAQ Switch Fan Config | 0=Never 1=Only While Occupied 2=Always | | 0 | | IAQINFAN | 41 |
| AQ.MN EC.MN OVR.P OA.CF | Econo Min IAQ Position Econo Minimum Position IAQ Override Position OAQ Analog Input Cfg | 0 to 100 0 to 100 0 to 100 0=No OAQ 1=Demand Ventilation 2=Outdoor Air Lockout | | 10 30 100 0 | | IAQMINP ECONOMIN IAQOVPOS OAQANCFG | 49 49, 50 49, 50 39, 49, 50, 82 |
| OAQ.L AQD.L AQD.H DF.ON DF.OF I.4M I.20M O.4M O.20M H.4M H.20M | OAQ Lockout Limit AQ Differential Low AQ Differential High Fan On AQ Differential Fan Off AQ Differential IAQ Sensor Value at 4mA IAQ Sensor Value at 20mA OAQ Sensor Value at 4mA OAQ Sensor Value at 20mA RH Sensor Value at 4mA RH Sensor Value at 20mA | 0 to 5000 0 to 5000 0 to 5000 0 to 5000 0 to 5000 0 to 5000 0 to 5000 0 to 5000 0 to 50 60 to 100 | | 600 100 700 600 200 0 2000 0 2000 0 % | | OAQLOCK DAQ_LOW DAQ_HIGH DAQFNON DAQFNOFF IAQ_4MA IAQ_20MA OAQ_4MA OAQ_20MA RH_4MA RH_20MA | 50 49 49 50 50 49 49 50 50 47 47 |
| ALM.O A.SPC A.SRT A.OAT A.CS A.CMP A.CKT A.SSP A.SCT A.FAN A.FIL A.TST A.ECO | Alarm Relay Configuration SPT/SPRH Sensor Failure SAT/RAT Sensor Failure OAT Thermistor Failure Current Sensor Failure Compressor Failure Refrigerant Circuit Failure SSP Transducer Failure SCT Thermistor Failure Indoor Fan Failure Dirty Filter Thermostat Failure Economizer Failure | Yes/No Yes/No Yes/No Yes/No Yes/No Yes/No Yes/No Yes/No Yes/No Yes/No Yes/No Yes/No Yes/No | | Yes Yes Yes Yes Yes Yes Yes Yes Yes Yes Yes Yes Yes | ALM_CFG | SPACE_AL SATRAT_AL OAT_AL CS_AL COMP_AL CKT_AL SSP_AL SCT_AL FAN_AL FILT_AL TSTAT_AL ECON_AL | 52 |
| TRIM SPT.C SPT.T SAT.C SAT.T RAT.C RAT.T | Sensor Calibration Space Temp Calibration Space Temp Trim Supply Air Temp Calib. Supply Air Temp Trim Return Air Temp Calib. Return Air Temp Trim | –30 to 120 –30 to 30 –30 to 130 –30 to 30 –30 to 130 –30 to 30 | | dF ^F dF ^F dF ^F | | (CCN TRIM — see Maintenance Display) | 64 64 64 64 64 |
| CCN CCN.A CCN.B BAUD | CCN Configuration CCN Element Number CCN Bus Number CCN Baud Rate | 1 to 239 0 to 239 1=2400 2=4800 3=9600 4=19200 5=38400 | | 1 0 3 | CONFIGURATION (not in CCN table) (not in CCN table) (not in CCN table) | | 35, 51 35, 51 35, 51 |
| BROD B.TIM B.OAT B.GS B.ACK | CCN Broadcast Configuration CCN Time/Date Broadcast CCN OAT Broadcast Global Schedule Broadcast CCN Broadcast Ack'er | Yes/No Yes/No Yes/No Yes/No | | No No No No | BRODEFS | CCNBC OATBC GSBC CCNBCACK | 51 51 40, 51 51 |
| SCH.O SCH.N HOL.G OV.TL OV.EX OV.SP | CCN Schedule Overrides Schedule Number Accept Global Holidays Override Time Limit Timed Override Hours SPT Override Enabled | 0=Always Occupied 1 to 64=Local Schedule 65 to 99=Global Schedule Yes/No 0 to 4 0 to 4 Yes/No | | 0 No 1 0 Yes | SCHEDOVR | SCHEDNUM HOLIDAYT OTL OVR_EXT TIMEOVER | 36, 40, 51 51 51 40, 52 40, 52 |

LEGEND

FIOP — Factory-Installed Option

APPENDIX A — LOCAL DISPLAY AND CCN TABLES (cont)
MODE — TIME CLOCK

| ITEM | EXPANSION | RANGE | UNITS | DEFAULT | CCN TABLE/ SUB-TABLE | CCN POINT |
|--|---|--|----------------|--|---|---|
| TIME CLOCK <i>TIME</i> TIME <i>DATE</i> MNTH DOM YEAR DAY | Time of Day Hour and Minute Current Date Month of Year Day of Month Year Day of Week | xx.xx 1 to 12 = January to December 1 to 31 xxxx 1 to 7 = Monday to Sunday | hh.mm | | CONFIGURATION (not in CCN table) (not in CCN table) (not in CCN table) (not in CCN table) | |
| DST STR.M STR.W STR.D M.ADD STP.M STP.W STP.D M.SUB | Daylight Savings Config Daylight Savings Start: Start Month Start Week Start Day Minutes to Add Daylight Savings Stop: Stop Month Stop Week Stop Day Minutes to Subtract | 1 to 12 = January to December 1 to 5 1 to 7 0 to 90 1 to 12 = January to December 1 to 5 1 to 7 0 to 90 | | 4 1 7 60 10 5 7 60 | BRODEFS | STARTM STARTW STARTD MINADD STOPM STOPW STOPD MINSUB |
| SCH.L PER.x OCC.x UNC.x MON.x TUE.x WED.x THU.x FRI.x SAT.x SUN.x HOL.x (repeat up to x= 8 Periods) | Occupancy Schedule Occupancy Period x Occupied From Occupied To Monday in Period Tuesday in Period Wednesday in Period Thursday in Period Friday in Period Saturday in Period Sunday in Period Holiday in Period | 00.00 to 23.59 00.00 to 23.59 Yes/No Yes/No Yes/No Yes/No Yes/No Yes/No Yes/No Yes/No | hh.mm hh.mm | 00.00 00.00 No No No No No No No No | (SCH.L = Display only) | |
| (OCCFECS = CCN only) | Occupancy Supervisory Period x DOW (MTWTFSSH) Occupied From Occupied To | xxxxxxxx 00.00 to 23.59 00.00 to 23.59 | hh.mm hh.mm | 00000000 00.00 00.00 | OCCDEFCS | DOWx OCCTODx UNOCTODx (repeat up to x= 8 Periods) |
| HOL.L HOL.x MON.x DAY.x LEN.x (repeat up to x= 9 Holidays) | Holiday Schedule Holiday x Holiday Start Month Holiday Start Day Holiday Duration (days) | 1 to 12 = January to December 1 to 31 1 to 99 | | 0 0 0 | HOLIDAY HOLDYxxS | HOL_MON HOL_DAY HOL_LEN (repeat up to xx= 30 Holidays) |

CCN ONLY TABLES

| ITEM | EXPANSION | RANGE | UNITS | DEFAULT | CCN TABLE/ SUB-TABLE | CCN POINT |
|------------------------------|--|--|------------|--|-------------------------|--|
| (ALARMDEF = CCN only) | Alarm Routing Control Equipment Priority Comm Failure Retry Time Re-Alarm Time Alarm System Name | 00000000 to 11111111 0 to 7 1 to 240 1 to 255 up to 8 alphanumeric | min min | 11000000 5 10 180 48_50_PG | ALARMDEF | ALRM_CNT EQP_TYPE RETRY_TM RE-ALARM ALRM_NAM |
| (CTRLID = CCN only) | Device Name: Description: Location: Software Part Number: Model Number: Serial Number: Reference Number: | 48_50_PG text string text string CESR131320-XX-XX | | | CTRL-ID | |

APPENDIX A — LOCAL DISPLAY AND CCN TABLES (cont)
MODE — OPERATING MODES

| ITEM | EXPANSION | RANGE | UNITS | CCN TABLE/ SUB-TABLE | CCN POINT | WRITE STATUS | |
|------------------------|---------------------------|-------------|-------|------------------------------|--------------|-----------------|----------|
| OPERATING MODES | | | | MAINTENANCE DISPLAY MODES | | | |
| MODE | Control Modes | | | | | | |
| SYS | System Mode | text string | | | SYS_MODE | Forcible | |
| HVAC | HVAC Mode | text string | | | HVACMODE | | |
| OCC | Currently Occupied | Yes/No | | | OCCUPIED | | |
| T.OVR | Timed Override in Effect | Yes/No | | | MODETOVR | | |
| LINK | Linkage Active | Yes/No | | | MODELINK | | |
| C.LOC | Comp Cool OAT Lockout | Yes/No | | | COMPCOOL | | |
| H.LOC | Heat OAT Lockout | Yes/No | | | HEATLOCK | | |
| E.LOC | Econ Cool OAT Lockout | Yes/No | | | ECONLOCK | | |
| COOL | Cool Mode Diagnostic | | | COOLDIAG | | | |
| COOL | In Cooling Mode? | Yes/No | | | IN_COOL | Forcible | |
| OK.CL | OK to Select Cool Mode? | Yes/No | | | OK TO COOL | | |
| MS.TG | Mode Select Timeguard | 0 to 999 | secs | | COOLMSTG | | |
| OK.EC | OK to Use Economizer? | Yes/No | | | ECONCOOL | | |
| OK.MC | OK to Use Compressors? | Yes/No | | | MECHCOOL | | |
| C.LOC | Circuit OAT Lockout | Yes/No | | | COMPCOOL | | |
| CA.LO | Circuit A Lockout Temp | 0 to 100 | dF | | OATLCMPA | | |
| CB.LO | Circuit B Lockout Temp | 0 to 100 | dF | | OATLCMPB | | |
| CC.LO | Circuit C Lockout Temp | 0 to 100 | dF | | OATLCMPC | | |
| AVL.C | Available Cooling | x | | | AVLCSTGS | | |
| REQ.C | Requested Cooling | x | | | REQCSTGS | | |
| ACT.C | Actual Compressors | x | | | ACTCSTGS | | |
| CMP.A | Circuit A Compressors | On/Off | | | COMP_A | | |
| CMP.B | Circuit B Compressors | On/Off | | | COMP_B | | |
| CMP.C | Circuit C Compressors | On/Off | | | COMP_C | | |
| ST.A | Circuit A Strikes | x | | | ASTRIKES | | |
| ST.B | Circuit B Strikes | x | | | BSTRIKES | | |
| ST.C | Circuit C Strikes | x | | | CSTRIKES | | |
| F.LEV | Outdoor Fan Level | x | | | FANLEV | | |
| SAT | Supply Air Temperature | | | | SAT | | |
| SAT | Supply Air Temperature | xxx.x | dF | | SAT_DMD | | |
| SA.DM | Supply Air Temp Demand | xxx.x | ^F | | SAT_POS | | |
| SA.PD | SAT Cool Demand (+) Level | xx.x | ^F | | SAT_NEG | | |
| SA.ND | SAT Cool Demand (-) Level | xx.x | ^F | | SATMIN_H | | |
| SAT.U | Minimum SAT Upper Level | xx.x | dF | | SATMIN_L | | |
| SAT.L | Minimum SAT Lower Level | xx.x | dF | | SAT_TREND | | |
| SA.TR | Supply Air d/dt (F/min) | xxxx.x | | | SAT_REF | | |
| SA.DR | SAT Delta Reference Temp | xxx.x | dF | | | | |
| SPT | Space Temperature | | | | SPACE_T | | Forcible |
| SPT | Space Temperature | xxx.x | dF | | COOL_DMD | | |
| DMD.C | Cooling Demand | xxx.x | ^F | | CLDTREND | | |
| TRD.C | Cool Demand d/dt (F/min) | xxx.x | | | DEM_POS | | |
| CL.PD | SPT Cool Demand (+) Level | xx.x | ^F | | DEM_NEG | | |
| CL.ND | SPT Cool Demand (-) Level | xx.x | ^F | | COOL_LAG | | |
| C.LAG | Cool Thermal Lag Factor | x.x | min | | | | |
| HMZR | Humidimizer | | | HUMIDIMIZER | | | |
| REHT | Humidimizer Equipped | Yes/No | | | REHEAT | Forcible | |
| HUM | Space Humidity Switch | High/Low | | | HUM_STAT | | |
| SPRH | Space Humidity Sensor | xxx.x | % | | SPRH | | |
| R.LO.A | Reheat2 OAT Lockout A | Yes/No | | F | RHALOCK | | |
| R.A.LO | Reheat2 OAT Limit A | xx | | F | OATLRH_A | | |
| R.L.P.A | Reheat2 SSP Override A | Yes/No | | | RHALPOV | | |
| R.LO.B | Reheat2 OAT Lockout B, C | Yes/No | | | RHBLOCK | | |
| RB.LO | Reheat2 OAT Limit B, C | xx | | | OATLRH_B | | |
| R.L.P.B | Reheat2 SSP Override B, C | Yes/No | | | RHBLPOV | | |
| AVL.R | Available Reheat2 Stages | x | | | AVLRSTGS | | |
| REQ.R | Requested Reheat2 Stages | x | | | REQRSTGS | | |
| ACT.R | Actual Reheat2 Stages | x | | | ACTRSTGS | | |
| CRC | Cool->Reheat1 Control | On/Off | | | CRC | | |
| RH2.A | Reheat2 Valve A | On/Off | | | RH2_A | | |
| RH2.B | Reheat2 Valve B, C | On/Off | | | RH2_B | | |
| HEAT | Heat Mode Diagnostic | | | HEATDIAG | | | |
| HEAT | In Heating Mode? | Yes/No | | | IN_HEAT | | Forcible |
| OK.HT | OK to Select Heat Mode? | Yes/No | | | OK TO HEAT | | |
| MS.TG | Mode Select Timeguard | 0 to 999 | secs | | HEATMSTG | | |
| H.LOC | Heat OAT Lockout | Yes/No | | | HEATLOCK | | |
| HT.LO | Heating Lockout Temp | 40 to 125 F | dF | | OATLHEAT | | |
| AVL.H | Available Heating Stages | x | | | AVLHSTGS | | |
| REQ.H | Requested Heating Stages | x | | | REQHSTGS | | |
| ACT.H | Actual Heating Stages | x | | | ACTHSTGS | | |
| HT.1 | Heat Stage 1 Relay | On/Off | | | HEAT_1 | | |
| HT.2 | Heat Stage 2 Relay | On/Off | | | HEAT_2 | | |
| SPT | Space Temperature | | | | SPACE_T | Forcible | |
| SPT | Space Temperature | xxx.x | dF | | HEAT_DMD | | |
| DMD.H | Heating Demand | xxx.x | ^F | | HTDTREND | | |
| TRD.H | Heat Demand d/dt (F/min) | xxx.x | | | HDEM_POS | | |
| HT.PD | SPT Heat Demand (+) Level | xx.x | ^F | | HDEM_NEG | | |
| HT.ND | SPT Heat Demand (-) Level | xx.x | ^F | | HEAT_LAG | | |
| H.LAG | Heat Thermal Lag Factor | x.x | min | | | | |

APPENDIX B — CONTROL MODES WITH HUMIDI-MIZER™ SYSTEM AND ECONOMIZER

Thermostat input shown for cooling demand (versus temperature sensor and set point). Humidistat input shown for dehumidification demand (versus relative humidity sensor and set point). Economizer cooling availability is dependent on outdoor temperature or enthalpy.

Circuit Subcooling mode = REHEAT 1

Circuit HGRH mode = hot gas reheat = REHEAT 2

Circuit ON mode = normal cooling

Thermostat Control type configuration = 0 = Adaptive, or Unit Control Type configuration = 3 = Space Temperature, for Dual-circuit and Tri-Circuit units results in added staging timers and flex between 1-stage Y1 and 2-stage Y1.

DUAL CIRCUIT UNITS 1-Stage Y1 (Thermostat Control Type configuration = 1) and 2-Stage Y1 (Thermostat Control Type configuration = 2)

| ECONO AVAILABLE? | Y1 | Y2 | HUMIDISTAT | CIRCUIT A | CIRCUIT B | ECONOMIZER | |
|------------------|-----|-----|------------|------------|------------|---------------|---------------------------|
| NO | OFF | OFF | LOW | OFF | OFF | Min. Position | (Econo closed if fan off) |
| NO | OFF | OFF | HIGH | HGRH | HGRH | Min. Position | |
| NO | ON | OFF | HIGH | Subcooling | HGRH | Min. Position | |
| NO | OFF | ON | HIGH | Subcooling | Subcooling | Min. Position | alarm T411: Y2 without Y1 |
| NO | ON | ON | HIGH | Subcooling | Subcooling | Min. Position | |
| NO | ON | OFF | LOW | ON | OFF | Min. Position | |
| NO | OFF | ON | LOW | ON | ON | Min. Position | alarm T411: Y2 without Y1 |
| NO | ON | ON | LOW | ON | ON | Min. Position | |
| YES | OFF | OFF | LOW | OFF | OFF | Min. Position | (Econo closed if fan off) |
| YES | OFF | OFF | HIGH | HGRH | HGRH | Min. Position | |
| YES | ON | OFF | HIGH | Subcooling | HGRH | Min. Position | |
| YES | OFF | ON | HIGH | Subcooling | Subcooling | Min. Position | alarm T411: Y2 without Y1 |
| YES | ON | ON | HIGH | Subcooling | Subcooling | Min. Position | |
| YES | ON | OFF | LOW | OFF or ON | OFF | Cooling | |
| YES | OFF | ON | LOW | OFF or ON | OFF or ON | Cooling | alarm T411: Y2 without Y1 |
| YES | ON | ON | LOW | OFF or ON | OFF or ON | Cooling | |

DUAL-CIRCUIT UNITS Digital (Thermostat Control Type configuration = 3)

| ECONO AVAILABLE? | Y1 | Y2 | HUMIDISTAT | CIRCUIT A | CIRCUIT B | ECONOMIZER | |
|------------------|-----|-----|------------|------------|------------|---------------|---------------------------|
| NO | OFF | OFF | LOW | OFF | OFF | Min. Position | (Econo closed if fan off) |
| NO | OFF | OFF | HIGH | HGRH | OFF | Min. Position | |
| NO | ON | OFF | HIGH | HGRH | HGRH | Min. Position | |
| NO | OFF | ON | HIGH | Subcooling | HGRH | Min. Position | |
| NO | ON | ON | HIGH | Subcooling | Subcooling | Min. Position | |
| NO | ON | OFF | LOW | ON | OFF | Min. Position | |
| NO | OFF | ON | LOW | ON | ON | Min. Position | |
| NO | ON | ON | LOW | ON | ON | Min. Position | |
| YES | OFF | OFF | LOW | OFF | OFF | Min. Position | (Econo closed if fan off) |
| YES | OFF | OFF | HIGH | HGRH | OFF | Min. Position | |
| YES | ON | OFF | HIGH | HGRH | HGRH | Min. Position | |
| YES | OFF | ON | HIGH | Subcooling | HGRH | Min. Position | |
| YES | ON | ON | HIGH | Subcooling | Subcooling | Min. Position | |
| YES | ON | OFF | LOW | OFF or ON | OFF | Cooling | |
| YES | OFF | ON | LOW | OFF or ON | OFF or ON | Cooling | |
| YES | ON | ON | LOW | OFF or ON | OFF or ON | Cooling | |

CONTROL SET POINT AND CONFIGURATION LOG

Model Number: _____
 Serial Number: _____
 Date: _____
 Technician: _____

Software Versions: _____
 MBB: CESR131320-- __ __
 ECB: CESR131249-- __ __
 MARQ: CESR131171-- __ __

INDICATE UNIT SETTINGS BELOW

Control Type: Thermostat / T-55 Space Temp. / T-56 Space Temp. / T-58 Space Temp.
 Set Points: Cooling Occupied: _____ Unoccupied: _____
 Heating Occupied: _____ Unoccupied: _____

MODE — CONFIGURATION

| ITEM | EXPANSION | RANGE | DEFAULT | ENTRY |
|----------------------|---|---|---|-------|
| CONFIGURATION | | | | |
| DISP | Display Configuration | | | |
| METR | Metric Display | On/Off | Off | |
| LANG | Language Selection | 0=English 1=Spanish 2=French 3=Portuguese | 0 | |
| PROT | Password Enable | Enable/Disable | Enable | |
| PSWD | Service Password | 0000 to 9999 | 1111 | |
| TEST | Test Display LEDs | On/Off | Off | |
| UNIT | | | | |
| S.DLY | Unit Configuration Start Up Delay | 0 to 600 sec | 30 | |
| U.CTL | Unit Control Type | 1=Auto Select 2=Thermostat 3=Space Sensor | 1 | |
| T.CTL | Thermostat Control Type | 0=Adaptive 1=1 Stage Y1 2=2 Stage Y1 | 0 | |
| OC.FN | Fan On When Occupied | Yes/No | Yes | |
| IDF.F | Shut Down on IDF Failure | Yes/No | Yes | |
| EC.EN | Economizer Installed | Yes/No | No: no FIOP Yes: FIOP | |
| FN.SW | Fan Status Switch | 0=No Switch 1=Normally Open 2=Normally Closed | 0: no FIOP 1: FIOP | |
| FL.SW | Filter Status Switch | 0=No Switch 1=Normally Open 2=Normally Closed | 0: no FIOP 1: FIOP | |
| FS.SW | Fire Shutdown Switch | 0=No Switch 1=Normally Open 2=Normally Closed | 0: no FIOP 1: FIOP | |
| RM.SW | Remote Occupancy Switch | 0=No Switch 1=Normally Open 2=Normally Closed | 0 | |
| SAT.T | SAT Settling Time | 10 to 900 sec | 240 | |
| SAT.H | SAT Heat Mode Sensing | Enable/Disable | Disable | |
| RAT.S | RAT Sensor On SPTO Input | Yes/No | No | |
| RH.S | RH Sensor ON OAQ Input | Yes/No | No | |
| RH.SW | Space Humidity Switch | 0=No Switch 1=Normal Open 2=Normal Closed | 0: no Humidi-MiZer FIOP 1: Humidi-MiZer FIOP | |
| TCS.C | Temp Cmp Strt Cool Factr | 0 to 60 mins | 0 | |
| TCS.H | Temp Cmp Strt Heat Factr | 0 to 60 mins | 0 | |
| COOL | | | | |
| N.CIR | Cooling Configuration Number of Circuits | 1 to 3 | 2 | |
| N.A | Compressors on Circuit A | 1 to 2 | 1 | |
| MRT.C | Compressor Min On Time | 120 to 999 sec | 180 | |
| MOT.C | Compressor Min Off Time | 300 to 999 sec | 300 | |
| RST.C | Runtime to Reset Strikes | 120 to 999 sec | 300 | |
| C.DEC | Cool Stage Decrease Rate | 120 to 999 sec | 300 | |
| C.INC | Cool Stage Increase Rate | 120 to 999 sec | 450 | |
| FOD.C | Fan-off Delay, Mech Cool | 0 to 600 sec | 60 | |
| CA.LO | Circuit A Lockout Temp | 0 to 100 dF | 0 | |
| CB.LO | Circuit B Lockout Temp | 0 to 100 dF | 0: no Humidi-MiZer FIOP Humidi-MiZer FIOP: | |
| CC.LO | Circuit C Lockout Temp | 0 to 100 dF | 0 | |
| ALM.N | Alert Each Strike | Yes/No | Yes | |

LEGEND

FIOP — Factory-Installed Option

Manufacturer reserves the right to discontinue, or change at any time, specifications or designs without notice and without incurring obligations.

MODE — CONFIGURATION (cont)

| ITEM | EXPANSION | RANGE | DEFAULT | ENTRY |
|-----------------------------|---------------------------|-----------------|---|-------|
| CONFIGURATION (cont) | | | | |
| COOL (cont) | | | | |
| SAT | Supply Air Temperature | | | |
| SA.PD | SAT Cool Demand (+) Level | 0.5 to 10 ^F | 1 | |
| SA.ND | SAT Cool Demand (-) Level | -10 to -0.5 ^F | -1 | |
| SAT.U | Minimum SAT Upper Level | 35.0 to 65.0 dF | 58 | |
| SAT.L | Minimum SAT Lower Level | 35.0 to 65.0 dF | 48 | |
| SPT | Space Temperature | | | |
| CL.PD | SPT Cool Demand (+) Level | 0.5 to 5 ^F | 1 | |
| CL.ND | SPT Cool Demand (-) Level | -5 to -0.5 ^F | -1 | |
| C.LAG | Cool Thermal Lag Factor | 0 to 5 min | 1 | |
| CIR.A | Circuit A | | | |
| CS.A1 | A1 Current Sensing | Enable/Disable | Disable (1-phase) Enable (3-phase) | |
| CS.A2 | A2 Current Sensing | Enable/Disable | Disable | |
| A1.FN | A Circuit Level 1 Fans | 0 to 7 | No Humidi-MiZer FIOP 1 (20, 24) 5 (28) Humidi-MiZer FIOP 1 | |
| A2.FN | A Circuit Level 2 Fans | 0 to 7 | No Humidi-MiZer FIOP 3 (20) 2 (24, 28) Humidi-MiZer FIOP 3 (20) 2 (24, 28) | |
| A3.FN | A Circuit Level 3 Fans | 0 to 7 | No Humidi-MiZer FIOP 3 (20, 24) 7 (28) Humidi-MiZer FIOP 3 | |
| CIR.B | Circuit B | | | |
| CS.B1 | B1 Current Sensing | Enable/Disable | Enable | |
| B1.FN | B Circuit Level 1 Fans | 0 to 7 | No Humidi-MiZer FIOP 4 Humidi-MiZer FIOP 1 | |
| B2.FN | B Circuit Level 2 Fans | 0 to 7 | No Humidi-MiZer FIOP 6 (20) 2 (24, 28) Humidi-MiZer FIOP 3 (20) 2 (24, 28) | |
| B3.FN | B Circuit Level 3 Fans | 0 to 7 | No Humidi-MiZer FIOP 6 Humidi-MiZer FIOP 3 | |
| CIR.C | Circuit C | | | |
| CS.C1 | C1 Current Sensing | Enable/Disable | Disable | |
| C1.FN | C Circuit Level 1 Fans | 0 to 7 | 0 | |
| C2.FN | C Circuit Level 2 Fans | 0 to 7 | 0 | |
| C3.FN | C Circuit Level 3 Fans | 0 to 7 | 0 | |
| SST | Low Suction Control | | | |
| SST.O | Suction OK Temperature | 10 to 50 dF | 18 | |
| SST.1 | Low Suction — Level 1 | 10 to 50 dF | 20 | |
| SST.2 | Low Suction — Level 2 | 5 to 50 dF | 15 | |
| SST.3 | Low Suction — Level 3 | 0 to 50 dF | 10 | |
| OFC | Outdoor Fan Control | | | |
| OFC.3 | OFC3 Enable. CCH | Yes/No | Yes | |
| 0.MXP | Fan Lev0 Max Pressure | 100 to 500 psig | 200 | |
| 1.MXP | Fan Lev1 Max Pressure | 100 to 500 psig | 450 | |
| 2.MNP | Fan Lev2 Min Pressure | 100 to 500 psig | 200 | |
| 2.ON | Fan Lev2 On Temperature | 0 to 100 F | no Humidi-MiZer FIOP: 55 (20) 45 (24-28) Humidi-MiZer FIOP: 68 (20) 61 (24) 61 (28) | |
| 2.OFF | Fan Lev2 Off Temperature | 0 to 100 F | no Humidi-MiZer FIOP: 50 (20) 40 (24-28) Humidi-MiZer FIOP: 57 (20) 57 (24) 57 (28) | |
| 2.MXP | Fan Lev2 Max Pressure | 100 to 500 psig | 400 | |
| 3.MNP | Fan Lev3 Min Pressure | 100 to 500 psig | 250 | |
| 3.ON | Fan Lev3 on Temperature | 0 to 100 F | no Humidi-MiZer FIOP: 65 Humidi-MiZer FIOP: 88 (20) 68 (24) 68 (28) | |

CUT ALONG DOTTED LINE

CUT ALONG DOTTED LINE

LEGEND

FIOP — Factory-Installed Option

MODE — CONFIGURATION (cont)

| ITEM | EXPANSION | RANGE | DEFAULT | ENTRY |
|--|--|---|--|-------|
| CONFIGURATION (cont) <i>OFC (cont)</i> 3.OFF | Fan Lev3 Off Temperature | 0 to 100 F | no Humidi-MiZer FIOP: 55 Humidi-MiZer FIOP: 78 (20) 62 (24) 62 (28) | |
| HMZR REHT | Humidimizer Config Humidimizer Equipped | Yes/No | No: no Humidi-MiZer FIOP Yes: Humidi-MiZer FIOP 60 | |
| R.DEC | Reheat2 Stage Decr. Time | 0 to 999 secs | 300 | |
| R.INC | Reheat2 Stage Incr. Time | 0 to 999 secs | Yes | |
| RH.FN | Reheat Fan Control | Yes/No | 2 | |
| RF.LV | Reheat2 ODF Fan On Level | 0 to 3 | 93 (20) 93 (24) 85 (28) | |
| RF.ON | Reheat2 ODF Fan On Temp | 0 to 100 F | 83 (20) 88 (24) 80 (28) | |
| RF.OF | Reheat2 ODF Fan Off Temp | 0 to 100 F | 40 | |
| RA.LO | Reheat2 OAT Limit A | 20 to 70 F | 80 | |
| RA.LP | Reheat2 SSP Lo Limit A | 50 to 100 psig | 90 | |
| RA.HP | Reheat2 SSP Hi Limit A | 50 to 100 psig | 50 | |
| RB.LO | Reheat2 OAT Limit B, C | 20 to 70 F | 80 | |
| RB.LP | Reheat2 SSP Lo Limit B, C | 50 to 100 psig | 90 | |
| RB.HP | Reheat2 SSP Hi Limit B, C | 50 to 100 psig | | |
| HEAT HT.TY | Heating Configuration Type of Heat Installed | 0 = No Heat 1 = Gas 2 = Electric | 0 (50 series with no electric heat) 1 (48 series) 2 (50 series with electric heat) | |
| N.HTR | Number of Heat Stages | 1 to 2 | 1 (48 series 1-phase, 50 series <15kW) 2 (48 series 3-phase, 50 series >=15kW) | |
| MRT.H | Heat Minimum On Time | 60 to 999 sec | 120 | |
| MOT.H | Heat Minimum Off Time | 60 to 999 sec | 120 | |
| H.DEC | Heat Stage Decrease Rate | 120 to 999 sec | 300 | |
| H.INC | Heat Stage Increase Rate | 120 to 999 sec | 450 | |
| FOD.E | Fan-off Delay, Elect Heat | 10 to 600 sec | 30 | |
| FOD.G | Fan-off Delay, Gas Heat | 45 to 600 sec | 45 | |
| HT.LO | Heating Lockout Temp | 40 to 125 dF | 75 | |
| SAT.H | SAT Heat Mode Sensing | Enable/Disable | Disable | |
| SPT | Space Temperature Sensor | | | |
| HT.PD | SPT Heat Demand (+) Level | 0.5 to 5 ^F | 1 | |
| HT.ND | SPT Heat Demand (-) Level | -5 to -0.5 ^F | -1 | |
| H.LAG | Heat Thermal Lag Factor | 0 to 5 min | 1 | |
| ECON EC.EN | Economizer Configuration Economizer Installed | Yes/No | No: no FIOP Yes: FIOP | |
| E.CTL | Economizer Control Type | 1=Digital, Position Feed- back 2=Digital, Command Feedback 3=Analog Control | 1 | |
| EC.MN | Econo Minimum Position | 0 to 100 % | 30 | |
| EC.MX | Econo Cool Max Position | 0 to 100 % | 100 | |
| EH.LO | Econo Cool Hi Temp Limit | 40 to 100 dF | 65 | |
| EL.LO | Econo Cool Lo Temp Limit | -30 to 50 dF | 0 | |
| UEFC | Unoccupied Free Cooling | 0=Disabled 1=Entire Unoccupied Period 2=PreOccupancy Time | 2 | |

LEGEND

FIOP — Factory-Installed Option

MODE — CONFIGURATION (cont)

| ITEM | EXPANSION | RANGE | DEFAULT | ENTRY |
|-----------------------------|--|--|--------------------------|-------|
| CONFIGURATION (cont) | | | | |
| ECON (cont) | | | | |
| FC.TM | Free Cool PreOcc Time | 1 to 9999 min | 120 | |
| FC.LO | Free Cool Low Temp Limit | 0 to 70 dF | 50 | |
| PE.EN | Power Exhaust Installed | Yes/No | No: no FIOP Yes: FIOP | |
| PE.1 | PE Stage1 Econo Position | 10 to 100 % | 40 | |
| PE.2 | PE Stage2 Econo Position | 10 to 100 % | 75 | |
| EN.SW | Enthalpy Switch | 0=No Switch 1=Normally Open 2=Normally Closed | 0: no FIOP 1: FIOP | |
| E.TRV | Economizer Travel Time | 5 to 300 sec | 150 | |
| E.MXB | Bottom Stage Max Econo | 0 to 100 % | 50 | |
| E.MXM | Middle Stage Max Econo | 1 to 100 % | 35 | |
| E.MXT | Top Stage Max Econo | 0 to 100 % | 25 | |
| E.DBD | Economizer PID Deadband | 0 to 25 % | 3 | |
| EC.P | Economizer PID — kP | 0.0 to 99.9 sec | 2.5 | |
| EC.I | Economizer PID — kI | 0.0 to 99.9 sec | 0.1 | |
| EC.D | Economizer PID — kD | 0.0 to 99.9 sec | 1 | |
| EC.DT | Economizer PID — rate | 10.0 to 180.0 sec | 15 | |
| AIR.Q | | | | |
| IA.CF | Air Quality Configuration IAQ Analog Input Config | 0=No IAQ 1=Demand Ventilation 2=Econ Position Override 3=Econ Min Position Control | 0: no FIOP 1: FIOP | |
| IA.FN | IAQ Analog Fan Config | 0=Never 1=Only While Occupied 2=Always | 0 | |
| II.CF | IAQ Switch Input Config | 0=No IAQ 1=DCV Normally Open 2=DCV Normally Closed 3=Override Normally Open 4=Override Normally Closed | 0 | |
| II.FN | IAQ Switch Fan Config | 0=Never 1=Only While Occupied 2=Always | 0 | |
| AQ.MN | Econo Min IAQ Position | 0 to 100 | 10 | |
| EC.MN | Econo Minimum Position | 0 to 100 | 30 | |
| OVR.P | IAQ Override Position | 0 to 100 | 100 | |
| OA.CF | OAQ Analog Input Cfg | 0=No OAQ 1=Demand Ventilation 2=Outdoor Air Lockout | 0 | |
| OAQ.L | OAQ Lockout Limit | 0 to 5000 | 600 | |
| AQD.L | AQ Differential Low | 0 to 5000 | 100 | |
| AQD.H | AQ Differential High | 0 to 5000 | 700 | |
| DF.ON | Fan On AQ Differential | 0 to 5000 | 600 | |
| DF.OF | Fan Off AQ Differential | 0 to 5000 | 200 | |
| I.4M | IAQ Sensor Value at 4mA | 0 to 5000 | 0 | |
| I.20M | IAQ Sensor Value at 20mA | 0 to 5000 | 2000 | |
| O.4M | OAQ Sensor Value at 4mA | 0 to 5000 | 0 | |
| O.20M | OAQ Sensor Value at 20mA | 0 to 5000 | 2000 | |
| H.4M | RH Sensor Value at 4mA | 0 to 50 % | 0 | |
| H.20M | RH Sensor Value at 20mA | 60 to 100 % | 100 | |
| ALM.O | | | | |
| A.SPC | Alarm Relay Configuration SPT/SPRH Sensor Failure | Yes/No | Yes | |
| A.SRT | SAT/RAT Sensor Failure | Yes/No | Yes | |
| A.OAT | OAT Thermistor Failure | Yes/No | Yes | |
| A.CS | Current Sensor Failure | Yes/No | Yes | |
| A.CMP | Compressor Failure | Yes/No | Yes | |
| A.CKT | Refrigerant Circuit Failure | Yes/No | Yes | |
| A.SSP | SSP Transducer Failure | Yes/No | Yes | |
| A.SCT | SCT Thermistor Failure | Yes/No | Yes | |
| A.FAN | Indoor Fan Failure | Yes/No | Yes | |
| A.FIL | Dirty Filter | Yes/No | Yes | |
| A.TST | Thermostat Failure | Yes/No | Yes | |
| A.ECO | Economizer Failure | Yes/No | Yes | |

CUT ALONG DOTTED LINE

CUT ALONG DOTTED LINE

MODE — CONFIGURATION (cont)

| ITEM | EXPANSION | RANGE | DEFAULT | ENTRY |
|-----------------------------|-----------------------------|---|---------|-------|
| CONFIGURATION (cont) | | | | |
| TRIM | Sensor Calibration | | | |
| SPT.C | Space Temp Calibration | -30 to 120 dF | | |
| SPT.T | Space Temp Trim | -30 to 30 ^F | 0 | |
| SAT.C | Supply Air Temp Calib. | -30 to 130 dF | | |
| SAT.T | Supply Air Temp Trim | -30 to 30 ^F | 0 | |
| RAT.C | Return Air Temp Calib. | -30 to 130 dF | | |
| RAT.T | Return Air Temp Trim | -30 to 30 ^F | 0 | |
| CCN | CCN Configuration | | | |
| CCN.A | CCN Element Number | 1 to 239 | 1 | |
| CCN.B | CCN Bus Number | 0 to 239 | 0 | |
| BAUD | CCN Baud Rate | 1=2400 2=4800 3=9600 4=19200 5=38400 | 3 | |
| BROD | CCN Broadcast Configuration | | | |
| B.TIM | CCN Time/Date Broadcast | Yes/No | No | |
| B.OAT | CCN OAT Broadcast | Yes/No | No | |
| B.GS | Global Schedule Broadcast | Yes/No | No | |
| B.ACK | CCN Broadcast Ack'er | Yes/No | No | |
| SCH.O | CCN Schedule Overrides | | | |
| SCH.N | Schedule Number | 0=Always Occupied 1 to 64=Local Schedule 65 to 99=Global Schedule | 0 | |
| HOL.G | Accept Global Holidays | Yes/No | No | |
| OV.TL | Override Time Limit | 0 to 4 hours | 1 | |
| OV.EX | Timed Override Hours | 0 to 4 hours | 0 | |
| OV.SP | SPT Override Enabled | Yes/No | Yes | |

