

Installation Instructions

Electric Heater Packages With DC Relay

KFCEH

NOTE: Read the entire instruction manual before starting the installation.
This symbol → indicates a change since the last issue.

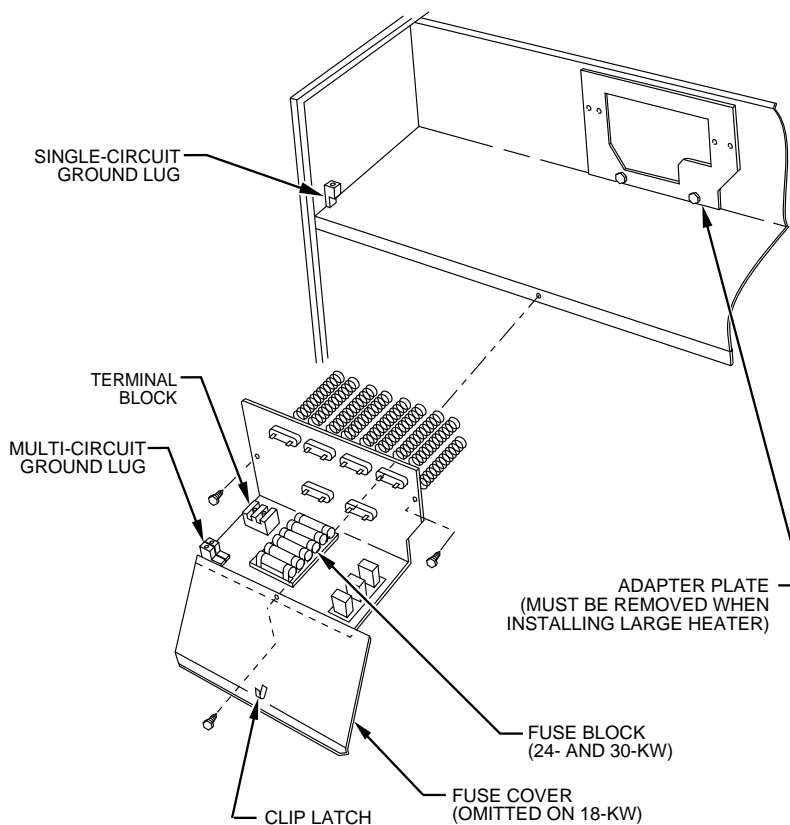

Fig. 1—Installation of 18-, 24-, and 30-kw Model Heaters

A90154

SAFETY CONSIDERATIONS

Installing and servicing heating and air conditioning equipment can be hazardous due to system pressures and electrical components. Only trained personnel should install or service heating and air conditioning equipment.

Untrained personnel can perform basic maintenance functions such as cleaning coils, or cleaning and replacing filters. All other operations should be performed by trained service personnel. When working on heating and air conditioning equipment, observe precautions in the literature, on tags, and on labels attached to the unit.

Follow all safety codes. Wear safety glasses and work gloves. Have a fire extinguisher available.

Recognize safety information. This is the safety-alert symbol ⚠.

When you see this symbol on the unit and in instructions or manuals, be alert to the potential for personal injury.

Understand the signal words DANGER, WARNING and CAUTION. These words are used with the safety-alert symbol. DANGER identifies the most serious hazards which **will** result in severe personal injury or death. WARNING signifies hazards which **could** result in personal injury or death. CAUTION is used to identify unsafe practices which **would** result in minor personal injury or product and property damage.

⚠ WARNING: Before beginning any installation or modification, be sure the main electrical disconnect switch is in the OFF position. Tag the disconnect switch with a suitable warning label. Electrical shock can cause personal injury or death.

INTRODUCTION

Table 1—Accessory Heater Usage

ELECTRIC HEATER PART NO.	KW	INTERNAL PROTECTION	MODEL FA, FB, PF SIZE	MODEL FC SIZE	MODEL FH SIZE	MODEL FX SIZE	MODEL FK4C, FV4A, 40FK SIZE	FK, FV, 40FK INTELLIGENT HEAT CAPABLE
1 Phase								
KFCEH0401N03	3	Non-fused	018, 024	024	001	—	—	NO
KFCEH0501N05 KFCEH0601C05	5	Non-fused Circuit Breaker	018-071	024-070	001-004	030-060	001-006	NO NO
KFCEH0801N08 KFCEH1001C08	8	Non-fused Circuit Breaker	018-071	024-070	001-004	030-060	001-006	NO NO
KFCEH1401N09	9*	Non-fused	036-071	036-070	002-004	036-060	001-006	YES†
KFCEH0901N10 KFCEH1101C10	10	Non-fused Circuit Breaker	018-071	024-070	001-004	030-060	001-006	NO NO
KFCEH1501F15 KFCEH1701C15	15	Fused Circuit Breaker	024-071	024-070	001-004	030-060	001-006	YES† YES†
KFCEH1801F20 KFCEH1901C20	20	Fused Circuit Breaker	030-071	030-070	002-004	030-060	001-006	YES† YES†
3 Phase Only								
KFCEH1601315	15	Non-fused	036-071	036-070	002-004	036-060	001-006	NO
KFCEH2001318	18	Non-fused	042-071	042-070	003, 004	042-060	003-006	NO
3 Phase, Factory Shipped‡								
KFCEH2101F24 KFCEH2201F30	24 30	Fused Fused	048-071	048-070	003, 004	048-060	005, 006	YES† YES†

† These heaters are Intelligent Heat capable when used with the FK4, FV4, and 40FK fan coils and corporate 2-speed programmable thermostat (TSTATXXP2S01-B), or Thermostat® Control (TSTATXXPRH01-B).

‡ Field convertible to 1 phase, single or multiple supply circuit.

* Field convertible to 3 phase.

Table 2—Minimum CFM and Motor Speed Selection

FAN COIL SIZES FA, FB, FC, FH, FX, PF	HEATER KW									
	3	5	8	9	10	15	18	20	24	30
018	525	525	525	—	600*	—	—	—	—	—
024	700	700	700	—	700	775*	—	—	—	—
030, 033	—	875	875	—	875	875	—	1060*	—	—
036, 038,	—	1050	970	970	970	920	—	1040	—	—
042	—	—	1225	1225	1225	1225	1225	1225	—	—
048, 054,	—	—	1400	1400	1400	1400	1400	1400	1400	1400
060, 070,	—	—	1750	1750	1750	1750	1750	1750	1750	1750

* Indicates medium speed (blue). All other motor speeds at low tap.

This instruction describes the installation of Part No. KFCEH accessory heaters in FA, FB, FC, FH, FX, and PF1MNA018-070 fan coils and in the FK4, FV4, 40FK, and PF1MNA071 fan coils.

NOTE: Electric heaters require a minimum airflow. Minimum airflow and motor speed selection are listed in Table 2. For 3- through 18-kw heaters there are no clearance requirements for the first 36 in. of ductwork. For 20- through 30-kw heaters, a 1-in. clearance is required for the first 36 in. of ductwork.

INSTALLATION

PROCEDURE 1—INSTALL ELECTRIC HEATER ASSEMBLY

NOTE: Ensure heater coils are not deformed or damaged during heater installation.

1. Make sure power to unit is off.
2. Remove blower access panel of fan coil unit.

⚠ CAUTION: Before installation of heater, the black and yellow pigtail leads must be removed from the fan coil PCB or wire harness to prevent possible damage to the product. Electrical power will be provided to the board through the heater circuit plug.

3. Disconnect 2 power wires (black and yellow pigtail leads) from PCB or wire harness (if applicable) and discard. Wires may be part of a plug assembly or attached to terminals L1 and L2. Remove cooling control plate from fan coil (if equipped). For 18-, 24-, and 30-kw heaters, remove adapter plate. (See Fig. 1.)
4. Insert heater assembly into front of fan coil so that element rods engage holes in rear heat shield.
5. Attach heater control plate to fan coil using 2 screws provided. For 18-, 24-, and 30-kw heater models, attach front of heater to fan deck using third screw. (See Fig. 1.)

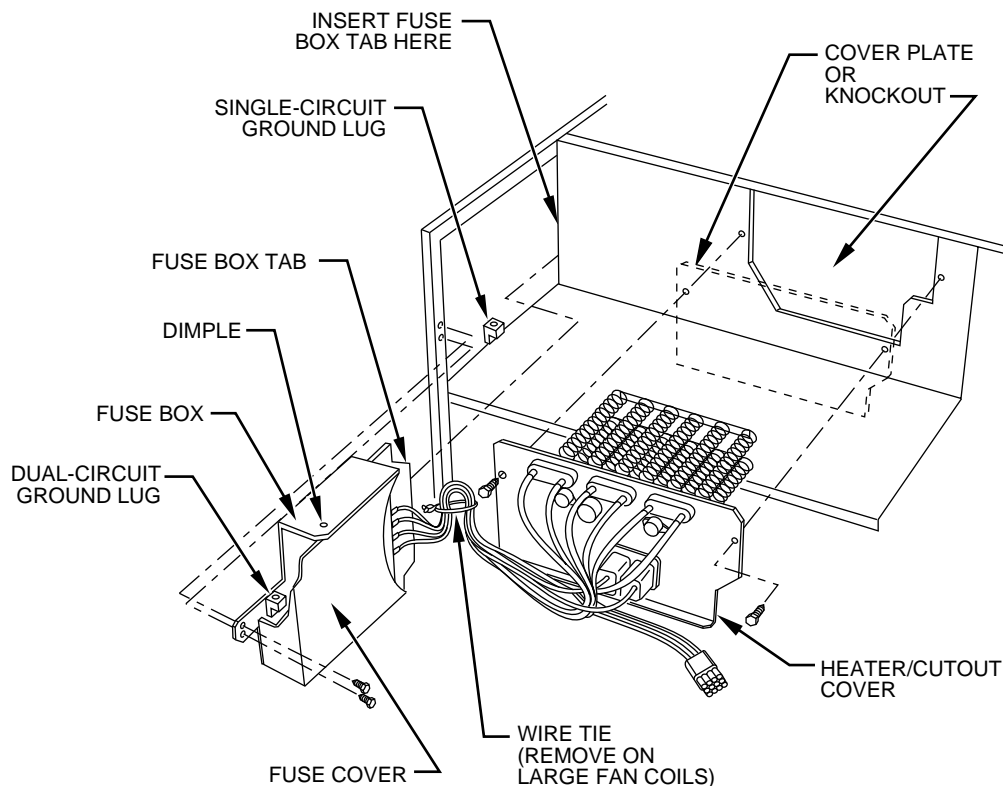

Fig. 2—Installation of Fused Model Heater

A90151

PROCEDURE 2—ATTACH FUSE BOX OR CIRCUIT BREAKER BOX

1. For 15- and 20-kw fused models:

After installing heater assembly, attach fuse assembly to side of fan coil unit by inserting fuse box tab between insulation and to left side of unit and fan deck. Mount front of assembly to side flange with 2 screws provided. On fan coil units size 042 and larger, remove wire tie that shortens wire length between heater and fuses. Fuse cover is closed by engaging dimples in fuse box. (See Fig. 2.)

2. For 24- and 30-kw fused models:

Fuse assembly is mounted on heater. Be sure fuse cover is closed by engaging clip latch on unit top panel. (See Fig. 1.)

⚠ WARNING: Ensure fuse box is closed before power is turned to ON position. Electrical shock may cause personal injury or death.

3. For 5- through 20-kw circuit breaker models:

After installing heater assembly, attach circuit breaker assembly to unit with screws provided. (See Fig. 3.) On fan coil units size 042 and larger, remove wire tie that shortens wire length between heater and circuit breaker assembly to allow mounting of circuit breaker assembly. (See Fig. 3.)

4. Circuit breaker models require installing a bezel in unit door to provide safe access to circuit breakers. Bezel mounts on inside of blower door. (See Fig. 4.)
 - a. Cut insulation away from access hole in blower access panel. Slide bezel flanges under insulation. Lip on bezel must protrude inward toward unit.
 - b. Secure bezel to panel with 2 No. 6 hex head screws. Insert screws through original cover plate holes on access panel and drive into engagement holes on bezel flanges.

PROCEDURE 3—ELECTRICAL CONNECTIONS

Refer to unit instructions for recommended wiring procedures. Install wiring in accordance with all applicable local and national codes. (See Tables 3, 4, and 5.)

Connect heater wiring harness plug to receptacle on PCB or wire harness. A positive connection must be made between plug and receptacle. Plug will interlock with receptacle when properly seated. Harness contains both 24-v control and high-voltage wiring.

NOTE: Units with or without electric heaters require a minimum CFM. Refer to unit wiring label to ensure the fan speed selected with electric heaters is equal to or greater than the minimum fan speed indicated. The minimum CFM for cooling is determined by the outdoor unit requirements. Use the higher of the 2 for year-round operation.

→ Table 3—Electric Heater Electrical Data

HEATER PART NO.	KW		PHASE	INTERNAL CIRCUIT PROTECTION	HEATER AMPS 208/230V			Min Wire Size (AWG) 208/230V††			Min Ampacity 208/230V**			Min Gnd Wire Size 208/230V			Max Fuse/Ckt Bkr Amps 208/230V			Max Wire Length 208/230V (Ft)‡‡		
	240V	208V			Single Circuit	Dual Circuit		Single Circuit	L1,L2	L3,L4	Single Circuit	L1,L2	L3,L4	Single Circuit	L1,L2	L3,L4	Single Circuit	L1,L2	L3,L4	Single Circuit	L1,L2	L3,L4
						L1,L2	L3,L4															
KFCEH0401N03	3	2.3	1	None	10.9/12.0	—	—	—	12/12	—	—	12/12	—	—	20/20	—	—	67/68	—	—		
KFCEH0501N05 ¹	5	3.8	1	None	18.1/20.0	—	—	—	10/10	—	—	10/10	—	—	30/30	—	—	66/66	—	—		
KFCEH0501N05 ²	5	3.8	1	None	18.1/20.0	—	—	—	8/8	—	—	8/8	—	—	35/35	—	—	85/88	—	—		
KFCEH0601C05 ¹	5	3.8	1	Ckt Bkr	18.1/20.0	—	—	—	10/10	—	—	10/10	—	—	30/30	—	—	66/66	—	—		
KFCEH0601C05 ²	5	3.8	1	Ckt Bkr	18.1/20.0	—	—	—	8/8	—	—	8/8	—	—	35/35	—	—	85/88	—	—		
KFCEH0801N08	8	6.0	1	None	28.9/32.0	—	—	—	8/8	—	—	8/8	—	—	45/50	—	—	59/60	—	—		
KFCEH1001C08	8	6.0	1	Ckt Bkr	28.9/32.0	—	—	—	8/8	—	—	8/8	—	—	45/50	—	—	59/60	—	—		
KFCEH1401N09***	9	6.8	1	None	32.8/36.0	—	—	—	8/8	—	—	8/8	—	—	50/60	—	—	54/87	—	—		
KFCEH1401N09†	9	6.8	3	None	18.8/20.8	—	—	—	8/8	—	—	8/8	—	—	35/35	—	—	83/85	—	—		
KFCEH0901N10	10	7.5	1	None	36.2/40.0	—	—	—	6/6	—	—	6/6	—	—	60/60	—	—	78/80	—	—		
KFCEH1101C10	10	7.5	1	Ckt Bkr	36.2/40.0	—	—	—	6/6	—	—	6/6	—	—	60/60	—	—	78/80	—	—		
KFCEH1501F15***	15	11.3	1	Fuse	54.2/59.9	36.2/40.0	18.1/20.0	53.8/58.5	22.7/25.0	4/4	6/6	10/10	10/10	10/10	80/90	60/60	25/25	88/89	78/80	75/76		
KFCEH1701C15***	15	11.3	1	Ckt Bkr	36.2/40.0	—	—	—	22.7/25.0	—	6/6	10/10	10/10	10/10	—	60/60	25/25	—	78/80	75/76		
KFCEH1601315	15	11.3	3	None	31.3/34.6	—	—	—	8/6	—	—	8/6	—	—	50/60	—	—	56/90	—	—		
KFCEH2001318	18	13.5	3	None	37.6/41.5	—	—	—	6/6	—	—	6/6	—	—	60/70	—	—	76/77	—	—		
KFCEH1801F20***	20	15.0	1	Fuse	72.3/79.9	36.2/40.0	36.2/40.0	53.8/58.5	45.3/50.0	3/2	6/6	8/8	8/8	10/10	100/110	60/60	50/50	85/109	78/80	59/59		
KFCEH1901C20***	20	15.0	1	Ckt Bkr	36.2/40.0	—	—	—	45.3/50.0	—	6/6	8/8	8/8	10/10	—	60/60	50/50	—	78/80	59/59		
KFCEH2101F24†††	24	18.0	3	Fuse	50.1/55.4	—	—	—	71.2/77.8	—	4/4	—	—	—	80/80	—	—	94/95	—	—		
KFCEH2101F24†††	24	18.0	1	Fuse	86.7/95.5	—	—	—	116.9/127.9	—	1/1	—	—	—	125/150	—	—	115/116	—	—		
KFCEH2201F30†††	30	22.5	3	Fuse	62.6/69.2	—	—	—	86.8/95.0	—	3/3	—	—	—	90/100	—	—	97/98	—	—		
KFCEH2201F30†††	30	22.5	1	Fuse	109.0/120.0	—	—	—	144.8/158.5	—	0/00	—	—	—	150/175	—	—	117/150	—	—		

→ Table 4—Smart Heat Electrical Data

HEATER PART NO.	KW		PHASE	INTERNAL CIRCUIT PROTECTION	HEATER AMPS 208/230V			Min Wire Size (AWG) 208/230V††			Min Ampacity 208/230V**			Min Gnd Wire Size 208/230V			Max Fuse/Ckt Bkr Amps 208/230V			Max Wire Length 208/230V (Ft)‡‡		
	240V	208V			Single Circuit	Dual Circuit		Single Circuit	L1,L2	L3,L4	Single Circuit	L1,L2	L3,L4	Single Circuit	L1,L2	L3,L4	Single Circuit	L1,L2	L3,L4	Single Circuit	L1,L2	L3,L4
						L1,L2	L3,L4															
KFCEH0101H10	9	6.8	1	None	32.5/35.9	—	—	—	44.0/48.3	—	8/8	—	—	10/10	—	—	45/50	—	60/61	—	—	
KFCEH0201H15	15	11.3	1	Fuse	54.2/59.9	39.7/43.9	14.4/16.0	73.2/80.3	49.7/54.9	23.4/25.4	4/4	8/6	10/10	10/10	80/90	50/60	25/30	92/92	53/85	73/74	73/74	
KFCEH0301H20	20	15.0	1	Fuse	72.3/79.9	36.2/40.0	36.2/40.0	97.2/106.7	52.0/56.8	45.3/50.0	3/2	6/6	8/8	8/6	100/110	60/60	50/50	87/111	81/82	93/93	93/93	

→ Table 5—Field Multipoint Wiring of 24- and 30-Kw Single Phase

HEATER PART NO.	KW		PHASE	HEATER AMPS 208/230V			MIN AMPACITY 208/230V**			MIN WIRE SIZE (AWG) 208/230V††			MIN GND WIRE SIZE 208/230V			MAX FUSE/CKT BKR AMPS 208/230V			MAX WIRE LENGTH (FT)‡‡		
	240V	208V		L1,L2	L3,L4	L5,L6	L1,L2	L3,L4	L5,L6	L1,L2	L3,L4	L5,L6	L1,L2	L3,L4	L5,L6	L1,L2	L3,L4	L5,L6	L1,L2	L3,L4	L5,L6
KFCEH2101F24†	24	18.0	1	28.9/32.0	28.9/32.0	28.9/32.0	44.7/48.5	36.2/40.0	36.2/40.0	8/8	8/8	8/8	10/10	45/50	40/40	40/40	59/60	73/73	73/73	73/73	
KFCEH2201F30†	30	22.5	1	36.2/40.0	36.2/40.0	36.2/40.0	53.8/58.5	45.3/50.0	45.3/50.0	6/6	8/8	8/8	10/10	60/60	50/50	50/50	78/80	59/59	59/59	59/59	

† Field convertible to 1 phase, single or multiple supply circuit.
 ‡ Field convertible to 3 phase.
 ** Includes blower motor amps of largest fan coil used with heater.
 †† Copper wire must be used. If other than uncoated (non-plated), 75°C ambient, copper wire (solid wire for 10 AWG and smaller, stranded wire for larger than 10 AWG) is used, consult applicable tables of the National Electric Code (ANSI/NFPA 70).
 ‡‡ Length shown is as measured 1 way along wire path between unit and service panel for a voltage drop not to exceed 2%.
 *** Heaters are Intelligent Heat capable when used with the FK4, FV4, and 40FK fan coils and corporate 2-speed programmable thermostat (TSTATXXP2S01-B), or Thermidistat™ Control (TSTATXXPRH01-B).
NOTES: 1. For fan coil sizes 018-036.
 2. For fan coil sizes 042-060 and all FK4C, FV4A, 40FK sizes.
 3. Single circuit application of F15 and F20 heaters requires single-point wiring kit accessory.

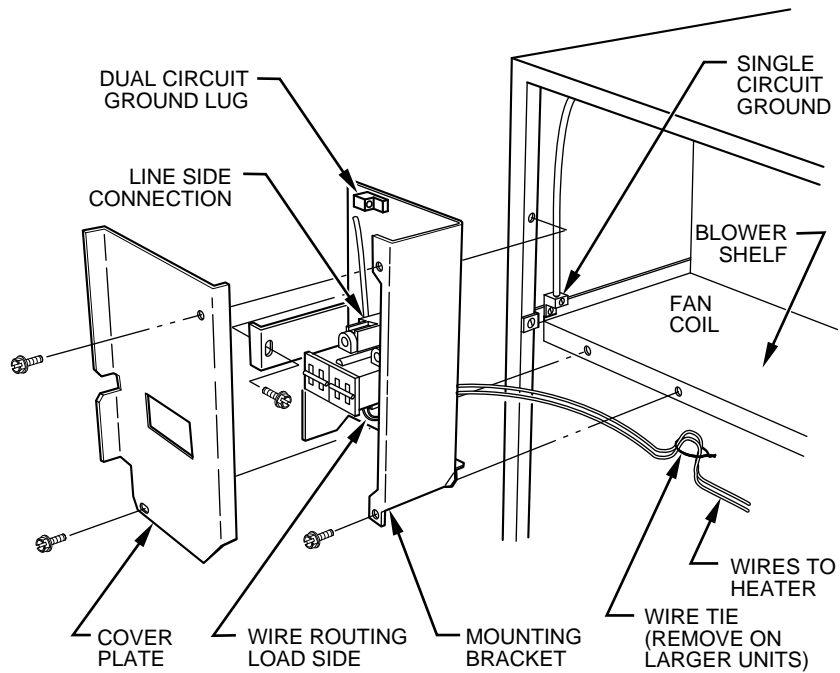

Fig. 3—Installation of Circuit Breaker Model Heater

A90153

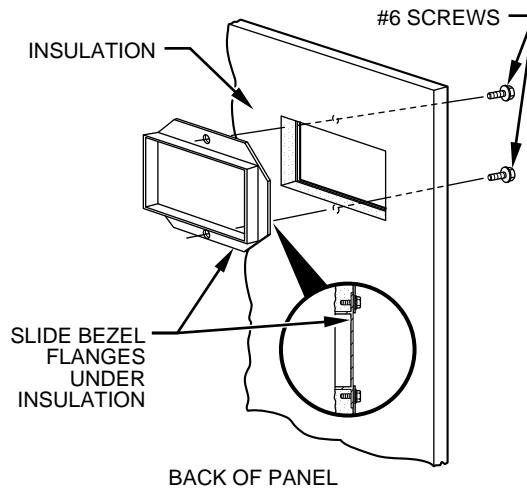

Fig. 4—Installation of Bezel for Circuit Breaker Model Heater

A90112

A. Wire 24-v Control Systems

1. Connections to unit

Use No. 18 AWG color-coded, insulated (35° C minimum) wire to make low-voltage connections between thermostat, fan coil unit, and outdoor unit. If thermostat is located more than 100 ft from unit (as measured along the low-voltage wire), use No. 16 AWG color-coded, insulated (35° C minimum) wire. All wiring must be separated from line voltage power leads. Refer to outdoor unit wiring instructions for additional wiring procedure recommendations.

2. Transformer

Transformer is factory wired for 230-v operation. For 208-v applications, disconnect black wire on transformer 230-v terminal and reconnect it to 208-v terminal. (See Fig. 5.) The secondary circuit of transformer is protected by a 5-amp fuse mounted on PCB.

CAUTION: If W2, W3, and E are individually connected on any 3 sequence heater (18, 20 24, 30 kw), as with outdoor thermostats or any other situation, an emergency heat relay must be used. This relay is in kit Part No. KHAOT0201SEC and is normally used with kit Part No. KHAOT0301FST for 2 outdoor thermostat systems.

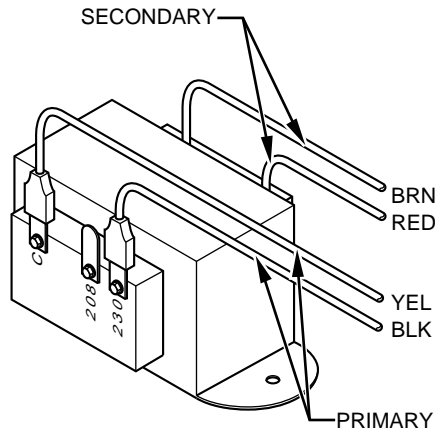

A94067

Fig. 5—Connection of Transformer

3. Heater staging

The units are shipped circuited for single-stage operation. Use outdoor thermostat kit Part No. KHAOT0301FST for 2-stage operation. Use both kit Part No. KHAOT0201SEC and KHAOT0301FST for 3-stage operation. When 2-stages are desired, cut W3 at the W2 wire nut, strip and reconnect per wiring staging layout in Installation Instructions for fan coils.

- a. The 3-, 5-, 8-, and 10-kw heaters are single stage only.
- b. The 9- and 15-kw heaters are adaptable for 2-stage operation.
- c. The 18-, 20-, 24-, and 30-kw heaters are adaptable for 3-stage operation.

4. Intelligent Heat Staging

40FK, FK4 and FV4 Fan Coils are capable of Intelligent Heat Staging when installed with Intelligent capable electric heaters (See Table 1) and a corporate 2-speed programmable thermostat (TSTATXXP2S01-B) or Thermidistat™ Control (TSTATXXPRH01-B). Consult the fan coil Installation and Set-up Instructions for wiring details. Do not install with outdoor thermostats when installing for Intelligent Heat Staging.

B. Power Connections

NOTE: Heater supply circuit wire size and overcurrent protection must comply with National Electrical Code (NEC) and UL branch circuit requirements. (See Tables 3, 4, and 5.) Wires and overcurrent protection, integral to the heater, are not required to meet branch circuit requirements. Internal circuit protection of 60 amps (maximum) is acceptable.

1. Unprotected heaters:

- a. The 5- through 10-kw single-phase and 15- and 18-kw 3-phase heaters can be wired for single-supply circuit only. Supply circuit connects to heater pigtail leads (terminal block on 18-kw heaters).
- b. The 3- through 10-kw single-phase heaters can use a separate field-installed, factory-authorized disconnect kit which installs in fan coil.

NOTE: Refer to wiring label for component locations.

→ c. The 9-kw heater is factory wired for single supply circuit, single phase. To convert heater to single supply circuit, 3 phase:

- (1.) Disconnect blue wire from limit switch (LS2). Cut, strip, and connect to field wire L3.
- (2.) Disconnect yellow wire from LS3 and connect to LS2.
- (3.) Disconnect blue wire from relay 2 terminal 2 and connect to LS3.

2. Circuit breaker heaters:

- a. The 3- through 10-kw heaters can be wired for single-supply circuit only.
- b. The 15- and 20-kw heaters can be wired for dual-supply circuits only.

3. Fused heaters:

- a. The 15- and 20-kw heaters can be wired for single- or dual-supply circuits. Single-supply circuit wiring requires a factory-authorized, single-point adapter kit.
- b. The 24- and 30-kw heaters can be wired for single- or multiple-supply circuits. Heaters are factory wired for single circuit 3 phase. To convert heaters to single circuit single phase, disconnect yellow lead from L3 and connect to L1. Disconnect black lead from L3 and connect to L2. To convert heaters to multiple-supply circuit single phase, remove and discard leads between single-circuit terminal block and fuse block. Remove and discard single-circuit terminal block. Attach L1 through L6 power leads as indicated on label next to fuse block.

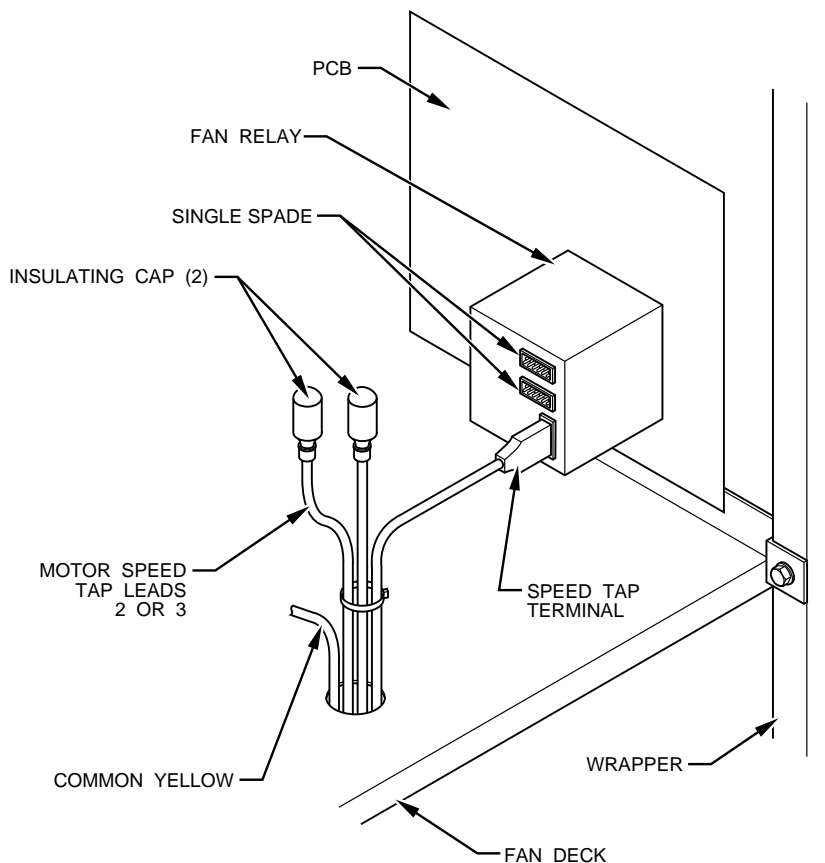

Fig. 6—Motor Speed Tap and Fan Relay

A94068

Table 6—Color Code for Motor Lead Wires FA, FB, FC, FH, FX, PF1MNA018—070 Units

MOTOR SPEED TAP	WIRE COLOR
Common	Yellow
High	Black
Medium	Blue (Factory selected)
Low	Red (Blue on 2-speed models)

C. Ground Connections

⚠ WARNING: According to NEC, ANSI/NFPA 70, and local codes, cabinet must have an uninterrupted or unbroken ground to minimize personal injury if an electrical fault should occur. The ground may consist of electrical wire or metal conduit when installed in accordance with existing electrical codes. Failure to follow this warning could result in an electric shock, fire, or death.

1. For unprotected or single-circuit heaters, 1 equipment ground connection is provided on fan coil unit. (See Fig. 1 or 2.)
2. For 15- and 20-kw circuit breaker heaters, an additional ground lug is provided on circuit breaker mounting bracket for dual-circuit grounding. (See Fig. 3.)
3. For 15- and 20-kw fused heaters, an additional ground lug is provided on fuse mounting bracket for dual-circuit grounding. (See Fig. 2.)
4. For 24- and 30-kw fused heaters, 2 additional ground lugs are provided for single-phase, multicircuit wiring. (See Fig. 1.)

D. Fan Speeds for FA, FB, FC, FH, FX, PF1MNA018—070 Fan Coils

1. Speed tap selection is done at fan relay. To change motor speeds, disconnect fan lead on relay and replace with motor speed tap desired. Save insulating cap and place on motor lead that was removed from relay. (See Fig. 6.) Refer to Table 6 for further clarification of speed tap selections.

E. FK4, FV4, 40FK, PF1MNA071

1. Refer to Table 7 and 8 for minimum CFM and airflow delivery.

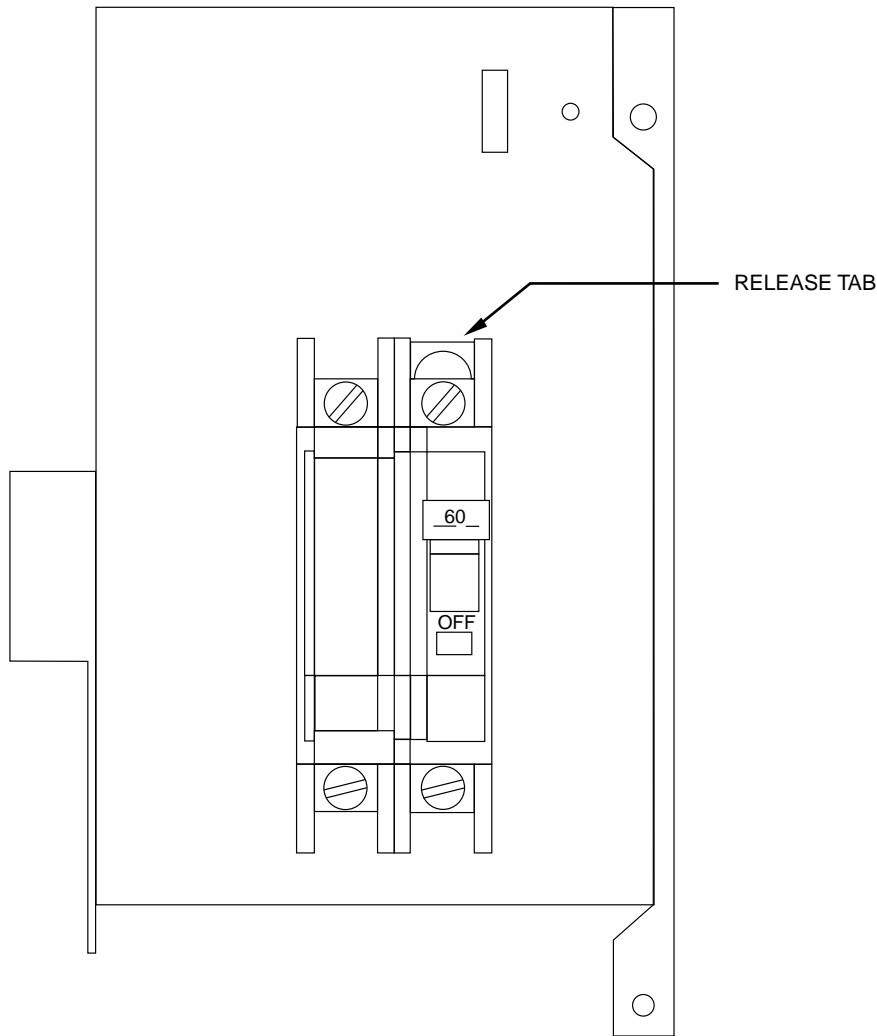

→ Fig. 7—Conversion of Circuit Breaker

A99094

→ **PROCEDURE 4—CONVERSION OF CIRCUIT BREAKER FOR DOWNFLOW APPLICATIONS**

1. Tag and disconnect factory wiring from terminals on circuit breaker(s).
2. Pull white plastic release tab on the bottom of circuit breaker straight out to release circuit breaker from bracket. (See Fig. 7.)
3. Remove quick connect adapters from factory side of breaker(s). Reinstall adapters on other end of breakers(s). Be sure adapter is located between lug screw and plate. Torque lug screw to 30-in.-lb.
4. Rotate breaker 180 degrees from its original position and reinstall in bracket. Slide breaker slot into sheet metal tab and snap breaker into place. Make sure both tabs engage breaker. Reconnect wiring on opposite end. Make sure wires are positioned as before.
5. Remount circuit breaker bracket into unit so that the switch will be in UP position when ON.

PROCEDURE 5—ATTACH WIRING DIAGRAM AND RATING LABEL

Attach heater rating label included with kit over existing electrical information label located on front access panel of fan coil. (See Fig. 8.) If kit contains multiple rating labels, ensure correct label is applied (check phase and supply circuits).

ON FA, FB, FC, FH, FX, AND PF1MNA018-070 MODELS, PLACE WIRING DIAGRAM LABEL 1 INCLUDED WITH KIT OVER EXISTING UNIT WIRING DIAGRAM LOCATED ON BLOWER HOUSING. DISCARD WIRING DIAGRAM LABEL 2.

ON MODEL FK4, FV4, 40FK OR PF1MNA071 PLACE WIRING DIAGRAM LABEL 2 INCLUDED WITH KIT OVER EXISTING UNIT WIRING DIAGRAM. DISCARD WIRING DIAGRAM LABEL 1.

PROCEDURE 6—VERIFY INSTALLATION

After completion of heater installation, check wiring to ensure tightness and that proper connections and routings have been made. Ensure all electrical covers are in place and proper labels have been applied. Reinstall blower access panel before turning unit power on.

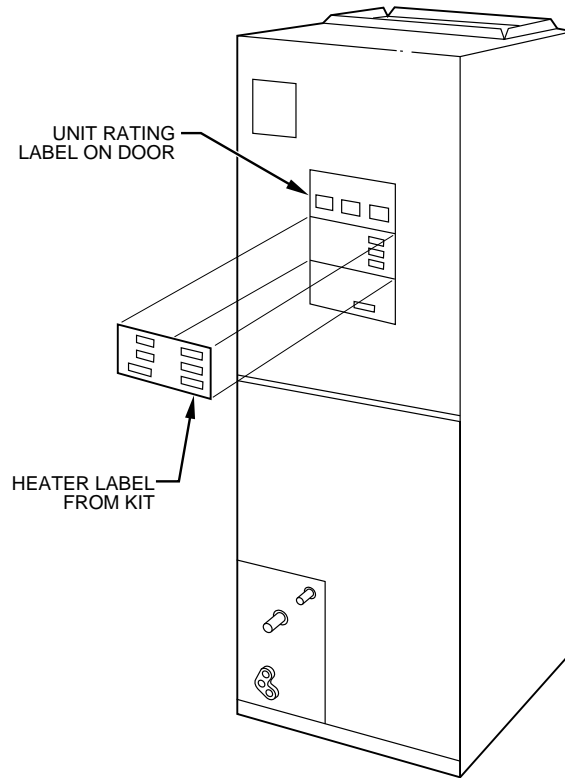

A96251

Fig. 8—Heater Rating Label Location

Table 7—FK4C, FV4A, 40FK, PF1MNA071 Airflow Delivery (CFM)

FAN UNIT SIZE	OUTDOOR UNIT CAPACITY BTUH	ELECTRIC HEATER KW RANGE											
		0—5			0—10			0—15			0—20		
		LO	NOM	HI	LO	NOM	HI	LO	NOM	HI	LO	NOM	HI
001 002	18,000	625	625	625	675	675	675	*	*	*	*	*	*
	24,000	650	725	835	*	725	835	875	875	875	*	*	*
	30,000	815	905	1040	*	905	1040	900	900	1040	1100	1100	1100
	36,000	980	1085	1250	980	1085	1250	980	1085	1250	1100	1100	1250
003	24,000	675	725	835	875	875	875	*	*	*	*	*	*
	30,000	815	905	1040	875	905	1040	1100	1100	1100	*	*	*
	36,000	980	1085	1250	980	1085	1250	1100	1100	1250	1225	1225	1250
	42,000	1140	1270	1460	1140	1270	1460	1140	1270	1460	1225	1270	1460
UNIT FAN SIZE	OUTDOOR UNIT CAPACITY BTUH	ELECTRIC HEATER KW RANGE											
		0—10			0—15			0—20			0—30		
		LO	NOM	HI	LO	NOM	HI	LO	NOM	HI	LO	NOM	HI
005	30,000	975	975	1040	1100	1100	1100	*	*	*	*	*	*
	36,000	980	1085	1250	1100	1100	1250	1250	1250	1250	*	*	*
	42,000	1140	1270	1460	1140	1270	1460	1250	1270	1460	1500	1500	1500
	48,000	1305	1450	1665	1305	1450	1665	1305	1450	1665	1500	1500	1665
006 071	36,000	1100	1100	1250	1350	1350	1350	*	*	*	*	*	*
	42,000	1140	1270	1460	1350	1350	1460	1525	1525	1525	*	*	*
	48,000	1305	1450	1665	1350	1450	1665	1525	1525	1665	1750	1750	1750
	60,000	1630	1810	2085	1630	1810	2085	1630	1810	2085	1750	1810	2085

* Airflow not recommended for heater/system size.

NOTE: LO, NOM, and HI refer to AC/HP CFM ADJUST selection.

Table 8—FK4C, FV4A, 40FK, PF1MNA071 Minimum CFM for Electric Heater Application (CFM)

FAN COIL UNIT	HEAT PUMP UNIT SIZE	CFM				
		HEATER SIZE KW				
		5	8, 9, 10	15	18, 20	24, 30
001 002	Heater Only	625	625	725	875	—
	018	625	625	—	—	—
	024	650	725	875	—	—
	030	800	875	875	1040	—
	036	970	970	970	1040	—
003	Heater Only	675	700	1050	1050	—
	024	675	875	1050	—	—
	030	800	875	1100	—	—
	036	975	975	1100	1225	—
	042	1125	1125	1125	1225	—
005	Heater Only	675	700	1050	1050	1400
	030	800	875	1100	—	—
	036	975	975	1100	1225	—
	042	1125	1125	1125	1225	—
	048	1305	1305	1305	1305	1400
006 071	Heater Only	1050	1050	1050	1050	1750
	036	1100	1100	1350	1350	—
	042	1125	1125	1350	1350	—
	048	1300	1300	1350	1465	1750
	060	1625	1625	1625	1750	1750

NOTES:

1. Heater Only—Air conditioner with electric heater application.
2. These airflows are minimum acceptable airflows as UL listed. Actual airflow delivered will be per airflow delivery chart for Electric Heating Modes.

