

Primary Cell Outlet Panel Kit

Cancels: IIK 340M-40-76 IIK 340M-40-90
8-05

Installation Instructions Part No. 330541-751, -752, -753, -754, -755, and -756

NOTE: Read the entire instruction manual before starting the installation.

This symbol → indicates a change since the last issue.

SAFETY CONSIDERATIONS

Installing and servicing of heating equipment can be hazardous due to gas and electrical components. Only trained personnel should install or service heating equipment.

Untrained personnel can perform basic maintenance functions such as cleaning and replacing filters. All other operations should be performed by trained service personnel. When working on heating equipment, observe precautions in the literature, on tags, and on labels attached to the unit.

Follow all safety codes. Wear safety glasses and work gloves. Have a fire extinguisher available.

Recognize safety information. This is the safety-alert symbol ⚠. When you see this symbol on the furnace and in instructions or manuals, be alert to the potential for personal injury.

Understand the signal words DANGER, WARNING, and CAUTION. These words are used with the safety-alert symbol. DANGER identifies the most serious hazards which **will** result in severe personal injury or death. WARNING signifies a hazard which **could** result in personal injury or death. CAUTION is used to identify unsafe practices which **may** result in minor personal injury or product and property damage. NOTE is used to highlight suggestions which **will** result in enhanced installation, reliability, or operation.

⚠ WARNING

FIRE, EXPLOSION AND ELECTRICAL SHOCK HAZARD

Failure to follow this warning could result in personal injury, death and/or property damage.

Turn off gas and electrical supplies to unit before beginning any installation or modification. Follow the operating instructions on label attached to furnace.

⚠ CAUTION

UNIT DAMAGE HAZARD

Failure to follow this caution may cause improper and dangerous operation.

Label all wires prior to disconnection when servicing controls.

INTRODUCTION

→ This instruction covers installation of the primary cell outlet panel kit Part No. 330541-751, -752, -753, -754, -755, and -756 in 40-in. tall, condensing gas furnaces.

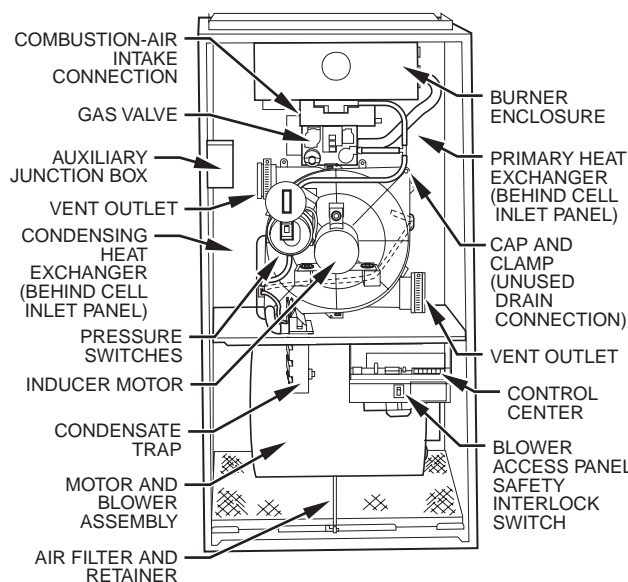

A01026

Fig. 1—Fixed and Two-Stage Models

→ **NOTE:** A releasing agent such as PAM cooking spray or equivalent (must not contain corn or canola oil, halogenated hydrocarbons nor aromatic contents to prevent inadequate seal) and RTV sealant (G.E. 162, G.E. 6702, or Dow-Corning 738) are needed before starting installation. DO NOT substitute any other type of RTV sealant. G.E. 162 (P771-9003) is available through RCD in 3-oz tubes.

DESCRIPTION AND USAGE

Use this primary cell outlet panel kit when repairing a primary cell outlet panel.

This primary cell outlet panel kit contains the following items:

Gasket (primary to condensing cell)	1
Primary cell outlet panel	1
Screw (No. 8D X 3/8-in. LG)	9 max
Screw (No. 8A X 1/2-in. LG)	4 max
Installation Instructions	1

INSTALLATION

Step 1—Remove Whole Cell Panel Assembly

See Fig. 1 and 2 for furnace component locations. See Fig. 3 for expanded view of heating system components.

NOTE: Actual component location may vary depending on model and series.

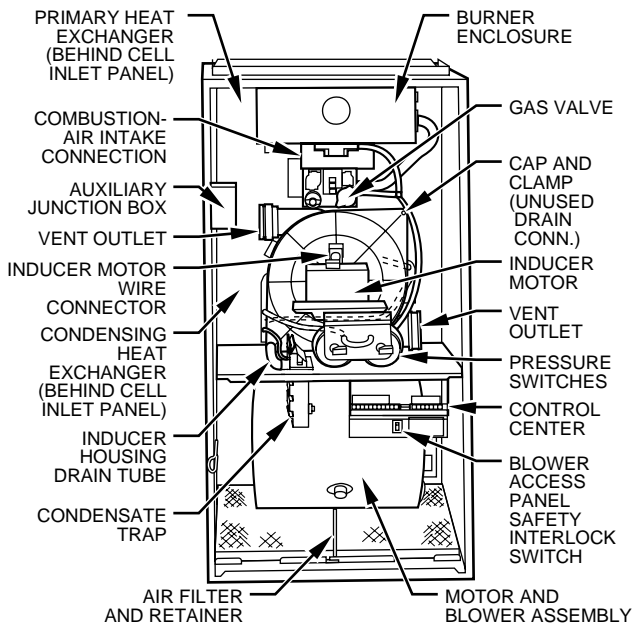

A93407

Fig. 2—Variable Capacity Models

1. Turn off gas and electrical supplies to furnace.
2. Remove main furnace door.
3. Remove blower access panel.
4. Disconnect field power supply wires from J-box.
5. Remove 2 screws securing J-box.
6. Remove 2 screws securing top filler panel and rotate panel upwards to remove or allow the heat exchanger to be removed from front of furnace.
7. Disconnect combustion-air intake pipe from intake housing and move pipe out of furnace casing.
8. Disconnect gas supply pipe from gas valve using backup wrench.
9. Disconnect vent pipe from inducer housing by loosening coupling clamp on inducer outlet. If coupling has 2 clamps, loosen clamp on vent pipe side. Move pipe out of furnace casing.
10. If control center is located in burner compartment of furnace, remove blower motor leads, transformer wires, door switch wires, and auxiliary limit switch wires (if present) from control center and pull wires through blower shelf.
11. If control center is located in blower compartment of furnace, disconnect wires from flame sensor, hot surface ignitor, overtemperature switch, gas valve, pressure switch(es), inducer motor, limit switch, and J-box, then pull wires through blower shelf.
12. Remove 2 screws securing blower to blower shelf (4 screws on 120 and 140 sizes).
13. Remove 2 screws adjacent to blower mounting screws that secure blower shelf to cell panel.
14. Remove 3 screws from each side of cell panel.
15. If control center is located in burner compartment of furnace, remove control center by removing screw and pressing tabs inward.
16. If control center was removed from furnace casing, secure control center (and J-box) to manifold for removal purposes only.
17. Disconnect drain tubes and relief port tube from condensate trap.
18. Disconnect field drain connections from condensate trap.
19. Remove condensate trap from furnace casing or blower shelf.

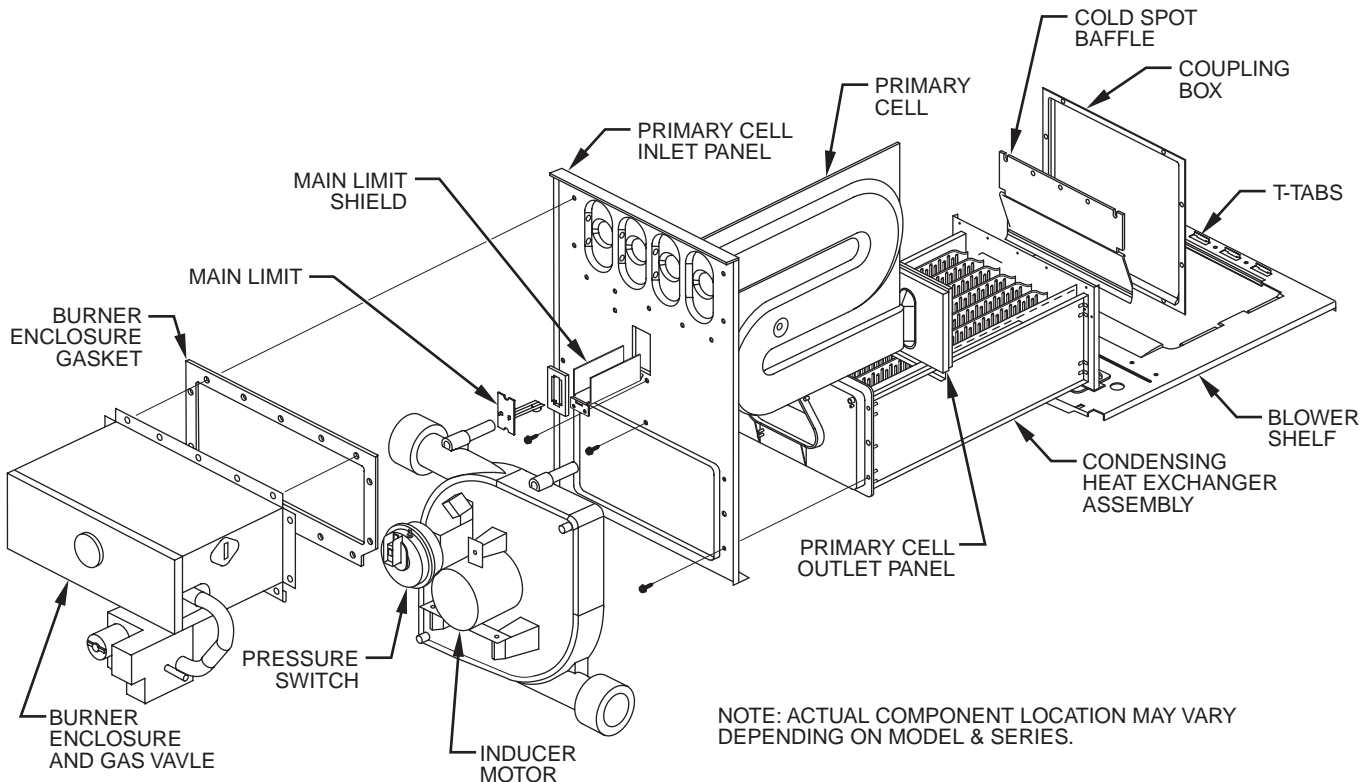

NOTE: ACTUAL COMPONENT LOCATION MAY VARY DEPENDING ON MODEL & SERIES.

A01027

Fig. 3—Expanded View of Heat System Components in Upflow Orientation

Table 1—Kit Usage

KIT PART NO.	UNIT									
	340AAV 350AAV 340MAV 350MAV 490AAV	351DAS	345MAV	352AAV 352MAV	355AAV 355MAV	58MCB 58MXB 58MCA 58MXA	58MSA	58MTB 58MTA	58MVB 58MVP	PG9MAB PG9MAA
330541-751	024040 036040	—	024040 036040	—	—	040-08 040-12	040-08 040-12	—	—	024040 036040
330541-752	024060 036060 048060	—	024060 036060 048060	036060	042060	060-08 060-12 060-16	060-08 060-12 060-16	060-12	060-14	024060 036060 048060
330541-753	036080 048080 060080	036080 048080 060080	036080 048080 060080	036080 048080	042080 060080	080-12 080-16 080-20	080-12 080-16 080-20	080-12 080-16	080-14 080-20	036080 048080 060080
330541-754	048100 060100	—	048100 060100	048100 060100	060100	100-16 100-20	100-16 100-20	100-16 100-20	100-20	048100 060100
330541-755	060120 060140	—	060120	060120	060120	120-20 140-20	120-20	120-20	120-20	060120 060140
330541-756	—	—	—	—	042040	—	—	—	040-14	—

20. Remove whole cell panel assembly with heat exchanger, burner box, inducer assembly, J-box (if applicable), and control center (if applicable) attached through front of furnace.

⚠ CAUTION

PERSONAL INJURY HAZARD

Failure to follow this caution may result in personal injury. Whole cell panel assembly is heavy. Get help to remove and lift assembly.

Step 2—Remove Coupling Box

1. Remove screws securing coupling box to primary cell outlet panel and condensing heat exchanger.
2. Break seal between top flange of coupling box and cell panel using screwdriver blade.
3. Remove coupling box.

Step 3—Remove Cold Spot Baffle

1. Remove all screws securing cold spot baffle to primary cell outlet panel and condensing heat exchanger.
2. Remove cold spot baffle.

Step 4—Install Primary Cell Outlet Panel

1. Remove screws securing primary cell outlet panel to primary cells.
2. Remove primary cell outlet panel by lifting panel off primary cells. Discard old primary cell outlet panel.
3. Attach new primary cell outlet panel to primary cells by doing the following:
 - a. Center new primary cell outlet panel over primary cell openings.
 - b. Use an awl to align holes and start ALL 3/8-in. screws (provided in kit) in primary cells.
 - c. After all screws are started, check position of fiberglass gasket and tighten screws in cells.
4. Position gasket between primary cell outlet panel and condensing heat exchanger assembly.

5. Start both end screws (1/2-in.), provided in kit, to properly locate primary cell outlet panel to condensing heat exchanger assembly. Leave screws loose for installation of cold spot baffle.

Step 5—Reinstall Cold Spot Baffle

1. Position cold spot baffle so positioning tab is facing away from condensing heat exchanger. Slide cold spot baffle under loose end screws.
2. Start screws that secure cold spot baffle to primary cell outlet panel. Use 1/2-in. screws provided in kit.

⚠ WARNING

CARBON MONOXIDE POISONING HAZARD

Failure to follow this warning could result in personal injury or death.

Ensure gasket between primary cell outlet panel and condensing heat exchanger assembly is in position to prevent leakage of combustion products.

3. Tighten all cold spot baffle screws.

Step 6—Reinstall Coupling Box

1. Clean old sealant from condensing heat exchanger assembly.
- 2. Apply sealant releasing agent such as PAM cooking spray or equivalent (must not contain corn or canola oil, halogenated hydrocarbons nor aromatic contents to prevent inadequate seal) to primary cell outlet panel and condensing heat exchanger surface where new coupling box sealant will mate. (See Fig. 3.)
3. Apply generous bead of RTV sealant (G.E. 162, G.E. 6702, or Dow-Corning 738) to coupling box flange. Sealant must not set more than 10 minutes prior to installation. (See Fig. 4.)
4. Attach coupling box using screws removed earlier, keeping coupling box movement to a minimum to avoid spreading sealant.

NOTE: Coupling box mounting holes will only align in 1 position. (See Fig. 3.)

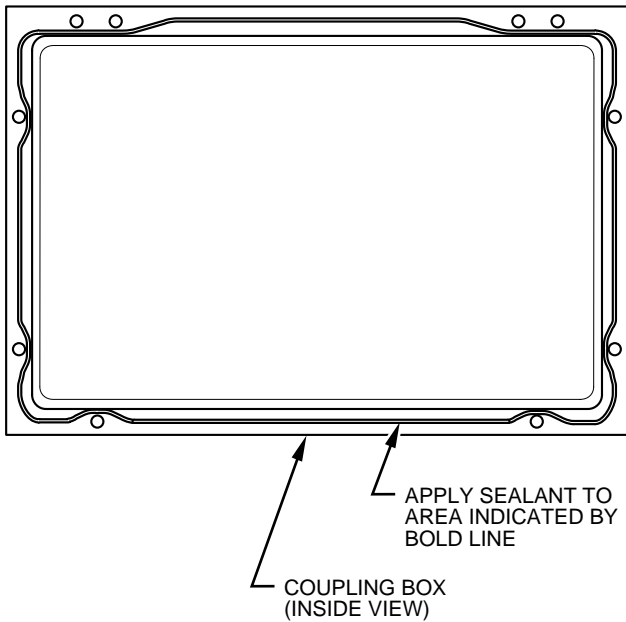

A93426

Fig. 4—Coupling Box Sealant Application

Step 7—Reinstall Whole Cell Panel Assembly

⚠ CAUTION

PERSONAL INJURY HAZARD

Failure to follow this caution may result in personal injury. Whole cell panel assembly is heavy. Get help to remove and lift assembly.

1. Install whole cell panel assembly with heat exchanger, burner box, inducer assembly, J-box (if applicable), and control center (if applicable) through front of furnace.

⚠ CAUTION

UNIT AND PROPERTY DAMAGE HAZARD

Failure to follow this caution may result in property damage. DO NOT cut or tear foil face insulation inside casing. If cuts or tears occur, repair insulation with foil tape.

2. Secure whole cell panel assembly to blower shelf by installing 2 screws through blower housing (4 screws on 120 and 140 sizes) and 2 screws adjacent to blower housing.

→ **NOTE:** When re-installing condensing heat exchanger assembly, the lower flange of the condensing heat exchanger cell rear panel must engage on the T-tabs in rear blower shelf. (See Fig. 3.)

3. Install 3 screws to each side of inlet cell panel and into cell panel supports.
4. If previously removed, reinstall control center in casing flange.

5. If control center is located in burner compartment or furnace, reinstall blower motor leads, transformer wires, door switch wires, and auxiliary limit switch wires (if present) through blower shelf and grommet.
6. If control is located in blower compartment of furnace, pull wires to flame sensor, hot surface ignitor, overtemperature switch, gas valve, pressure switch(es), inducer motor, limit switch, and J-box through blower shelf.
7. Install J-box.
8. Reattach wires to control center or components. See wiring diagram on furnace for proper attachment.
9. Reinstall condensate trap in furnace casing or blower shelf.
10. Connect field drain to condensate trap.
11. Reconnect condensate trap drain tubes. See tubing diagram on furnace for proper tube location.

NOTE: Ensure tubes are not kinked or pinched, as this will affect operation.

- 12. Connect vent pipe by inserting pipe through the elastomeric (rubber) coupling and then fully into inducer housing outlet. Tighten coupling clamp screw(s) to 15 in.-lb of torque.
13. Connect combustion-air intake pipe to intake housing and install screw to secure. Do not use RTV unless previously used.
14. Install top filler panel.
15. Install gas supply pipe to gas valve using backup wrench.

NOTE: Use propane gas resistant pipe dope to prevent gas leaks. DO NOT use Teflon tape.

⚠ WARNING

FIRE AND EXPLOSION HAZARD

Failure to follow this warning could result in personal injury, death and/or property damage. For upflow or downflow applications, gas valve knob or switch must be facing forward or tipped to the UP position.

16. Connect field power supply to J-box.
17. Install blower access panel.
18. Turn on gas and electrical supplies to furnace.
19. Check for gas leaks.

⚠ WARNING

FIRE AND EXPLOSION HAZARD

Failure to follow this warning could result in personal injury, death and/or property damage. Never use matches, candles, flame, or other sources of ignition to check for gas leakage. Use a soap-and-water solution.

20. Check furnace operation through 2 cycles.
21. Check for condensate leaks.
22. Replace main furnace door.