

Product Data



Fig. 1 —Sizes 09K - 24K

NOTE: Images are for illustration purposes **only**. Actual models may differ slightly.

TABLE OF CONTENTS

	PAGE
INDUSTRY LEADING FEATURES / BENEFITS	1
MODEL NUMBER NOMENCLATURE	3
STANDARD FEATURES AND ACCESSORIES	4
DIMENSIONS	5
CLEARANCES.....	5
SPECIFICATIONS	6
COMPATIBILITY.....	6
APPLICATION DATA	7
WIRING	7
WIRING DIAGRAMS.....	11
GUIDE SPECIFICATIONS.....	13

INDUSTRY LEADING FEATURES / BENEFITS

A PERFECT BALANCE BETWEEN BUDGET LIMITS, ENERGY SAVINGS AND COMFORT.

The **DLFSHB** series ductless systems are a matched combination of an outdoor condensing unit and an indoor fan coil unit connected only by refrigerant tubing and wires.

The fan coil is mounted on the wall, near the ceiling. This selection of fan coils permits creative solutions to design problems such as:

- Add-ons to current space (an office or family room addition)
- Special space requirements
- When changes in the load cannot be handled by the existing system
- When adding air conditioning to spaces that are heated by hydronic or electric heat and have no ductwork
- Historical renovations or any application where preserving the look of the original structure is essential.

The ideal compliment to your ducted system when it is impractical or prohibitively expensive to use ductwork. These compact indoor fan coil units take up very little space in the room and do not obstruct windows. The fan coils are attractively styled to blend with most room decors.

Advanced system components incorporate innovative technology to provide reliable cooling performance at low sound levels.

LOW SOUND LEVELS

When noise is a concern, the ductless systems are the answer. The indoor units are whisper quiet. There are no compressors indoors, either in the conditioned space or directly over it, and there is none of the noise usually generated by air being forced through ductwork.

SECURE OPERATION

If security is an issue, outdoor and indoor units are connected only by refrigerant piping and wiring to prevent intruders from crawling through ductwork. In addition, since the outdoor units can be installed close to an outside wall, coils are protected from vandals and severe weather.

FAST INSTALLATION

This compact ductless system is simple to install. A mounting bracket is standard with the indoor units and only wire and piping need to be run between the indoor and outdoor units. These units are fast and easy to install ensuring minimal disruption to customers in the home or workplace. This makes the **DLFSHB** ductless systems the equipment of choice, especially in retrofit situations.

SIMPLE SERVICING AND MAINTENANCE

Removing the top panel on outdoor units provides immediate access to the control compartment, providing a service technician access to check unit operation. In addition, the draw-thru design of the outdoor section means that dirt accumulates on the outside surface of the coil. Coils can be cleaned quickly from the inside using a pressure hose and detergent.

On all indoor units, service and maintenance expense is reduced due to easy-to-use cleanable filters. In addition, these high wall systems have extensive self-diagnostics to assist in troubleshooting.

BUILT-IN RELIABILITY

Ductless system indoor and outdoor units are designed to provide years of trouble-free operation. The high wall indoor units include protection against freeze-up and high evaporator temperatures on heat pumps. The condensing units on heat pumps are protected by a three minute time delay before the compressor starts the over-current protection and the high temperature protection.

INDIVIDUAL ROOM COMFORT

Maximum comfort is provided because each space can be controlled individually based on usage pattern. The air sweep feature provided permits optimal room air mixing to eliminate hot and cold spots for occupant comfort. In addition, year-round comfort can be provided with heat pumps.

ECONOMICAL OPERATION

The ductless system design allows individual room heating or cooling when required. There is no need to run large supply-air fans or chilled water pumps to handle a few spaces with unique load patterns. In addition, because air is moved only in the space required, no energy is wasted while air moves through the ducts.

EASY-TO-USE CONTROLS

The high wall units have microprocessor-based controls to provide the ultimate in comfort and efficiency. The user friendly wireless remote control provides the interface between the user and the unit.

ACCESSORIES

Customizing these ductless systems to your application is easily accomplished.

Adding a condensate pump accessory to the high wall fan coil provides installation flexibility.

OPTIONAL WIRED CONTROLLER

OPTIONAL 24V INTERFACE FOR THIRD PARTY CONTROL

OPTIONAL WI-FI KIT FOR SMART PHONE CONTROL

AGENCY LISTING

All systems are listed with AHRI (Air Conditioning, Heating & Refrigeration Institute), and ETL.

MODEL NUMBER NOMENCLATURE

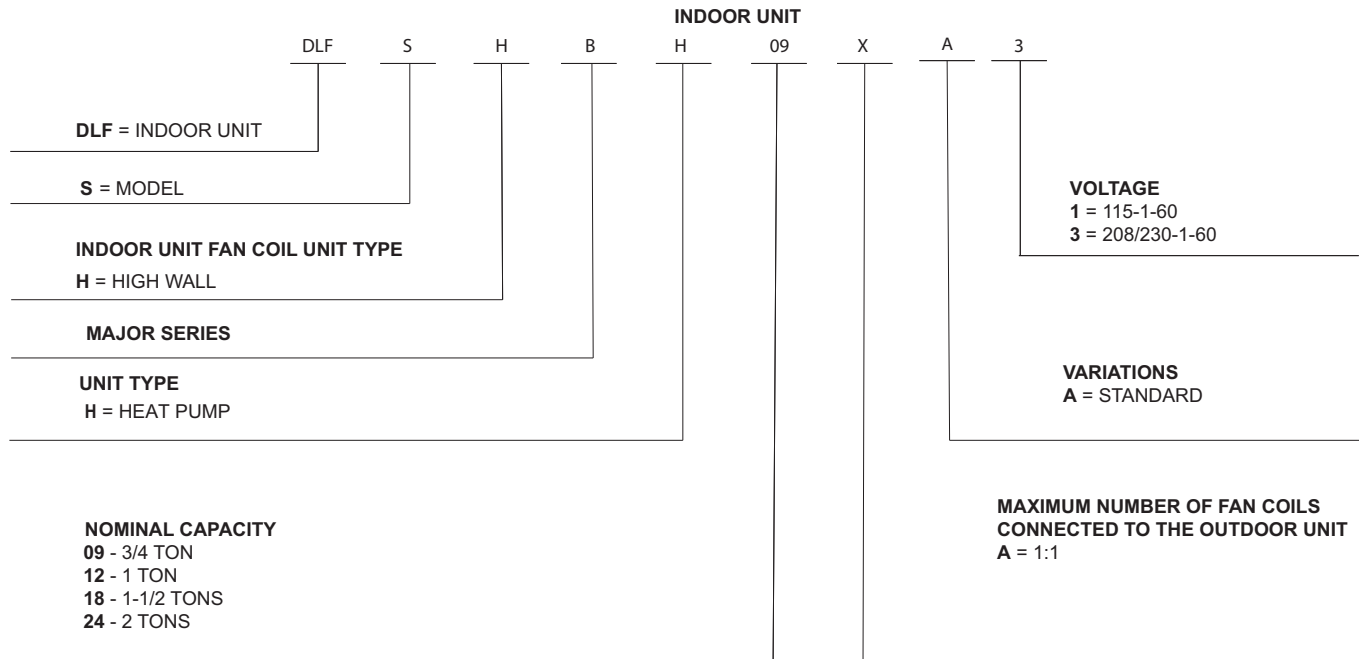

Use of the AHRI Certified TM Mark indicates a manufacturer's participation in the program For verification of certification for individual products, go to www.ahridirectory.org.



STANDARD FEATURES AND ACCESSORIES

Ease Of Installation	
Mounting Brackets	S
Low Voltage Controls	S
Stencil Template	S
Comfort Features	
Microprocessor Controls	S
Wired Remote Controller	A
Wireless Remote Controller	S
Automatic Up-Down Airflow Louver Swing	S
Air Direction Control	S
Auto Restart Function	S
Wi-Fi Control	A
Cold Blow Protection On Heat Pumps	S
Freeze Protection Mode on Heat Pumps	S
Turbo Mode	S
Silence Mode	S
Auto Changeover on Heat Pumps	S
Follow Me	S
ECO Mode	S
Energy Saving Features	
Sleep Mode	S
Stop/Start Timer	S
46° F Heating Mode (Heating Setback)	S
Safety And Reliability	
Indoor Coil Freeze Protection	S
Indoor Coil High Temp Protection in Heating Mode	S
Aluminum Hydrophilic pre-coated fins	S
Ease Of Service And Maintenance	
Cleanable Filters	S
Diagnostics	S
Carbon Filter	S
Application Flexibility	
Condensate Pumps	A

Legend

S - Standard
A - Accessory

ACCESSORIES

Accessory No.	Description	For Models
KSACN0901AAA	Wired Remote Control 7 Day Programmable	All Sizes
KSACN0101AAA	Wired Remote Control with Timer Function	All Sizes
KSAIC0401230	24V Interface Kit 230V	208/230 Models**
KSAIF0601AAA	Wi-Fi™ Kit High Wall Mid-Tier	All Sizes

DIMENSIONS



Fig. 2 — Dimensions

HIGH WALL UNIT SIZE		12K	9K	12K	18K	24K
(Voltage)		(115V)	(208/230V)	(208/230V)	(208/230V)	(208/230V)
Height (H)	In/ (mm)	11.61(295)	11.61(295)	11.61(295)	13.27(337)	13.27(337)
Width (W)	In/ (mm)	31.57(802)	31.57(802)	31.57(802)	42.60(1082)	42.60(1082)
Depth (D)	In/ (mm)	7.87(200)	7.87(200)	7.87(200)	9.21 (234)	9.21 (234)
Weight - Net	lbs. (kg)	18.96(8.6)	18.96(8.6)	18.96(8.6)	29.54(13.4)	29.98(13.6)

CLEARANCES

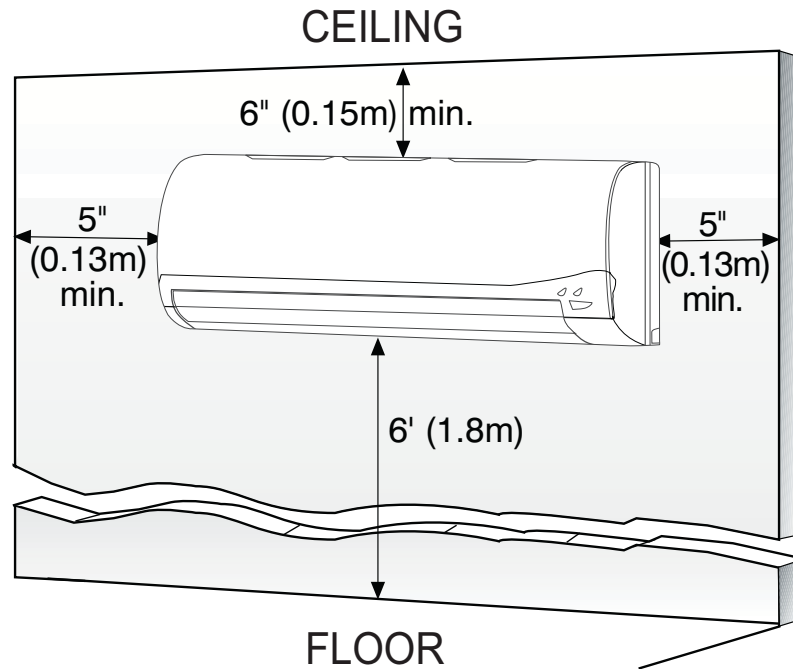

Fig. 3 — Indoor Unit Clearances

NOTE: The top clearance recommended for proper return airflow is 5.9in (15cm). Reduction of this clearance may decrease unit performance. This may be reduced to 2.0in (50mm) as long as the right and left clearances are achieved.

SPECIFICATIONS

SYSTEM	SIZE		12	9	12	18	24
	Indoor Model		DLFSHBH12XAJ	DLFSHBH09XAK	DLFSHBH12XAK	DLFSHBH18XAK	DLFSHBH24XAK
Electrical	Voltage, Phase, Cycle	V/Ph/Hz	115-1-60	208/230-1-60	208/230-1-60	208/230-1-60	208/230-1-60
	Power Supply						
	MCA	A.	0.31	0.19	0.19	0.5	0.5
Controls	Wireless Remote Controller (°F/°C Convertible)		Standard	Standard	Standard	Standard	Standard
	Wired Remote Controller (°F/°C Convertible)		Optional	Optional	Optional	Optional	Optional
Operating Range	Cooling Indoor DB Min - Max	°F(°C)	62~90 (17~32)	62~90 (17~32)	62~90 (17~32)	62~90 (17~32)	62~90 (17~32)
	Heating Indoor DB Min - Max	°F(°C)	32~86 (0~30)	32~86 (0~30)	32~86 (0~30)	32~86 (0~30)	32~86 (0~30)
Piping	Pipe Connection Size - Liquid	in (mm)	1/4 (6.35)	1/4 (6.35)	1/4 (6.35)	1/4 (6.35)	3/8 (9.52)
	Pipe Connection Size - Suction	in (mm)	1/2 (12.7)	3/8 (9.52)	1/2 (12.7)	1/2 (12.7)	5/8 (16)
Indoor Coil	Face Area	Sq. Ft.	1.9	1.9	1.9	3.0	3.0
	No. Rows		2.05	2.05	2.05	2.67	2.67
	Fins per inch		20	20	20	20	20
	Circuits		2	2	2	4	4
Indoor	Unit Width	in (mm)	31.57 (802)	31.57 (802)	31.57 (802)	42.60 (1082)	42.60 (1082)
	Unit Height	in (mm)	11.61 (295)	11.61 (295)	11.61 (295)	13.27 (337)	13.27 (337)
	Unit Depth	in (mm)	7.87 (200)	7.87 (200)	7.87 (200)	9.21 (234)	9.21 (234)
	Net Weight	lbs (kg)	18.96 (8.6)	18.96 (8.6)	18.96 (8.6)	29.54 (13.4)	29.98 (13.6)
	Number of Fan Speeds		4	4	4	4	4
	Airflow (lowest to highest)	CFM	176/241/300/341	152/194/291/341	152/194/291/341	382/458/531/761	382/459/601/761
	Sound Pressure (lowest to highest)	dB(A)	29.8/32.3/38.6	32.3/35.5/41.2	32.9/35.6/41	37.9/40.9/46.3	41/45.1/49.8
	Air throw Data	ft (m)	23 (7)	19.7 (6)	22.3 (6.8)	31.8 (9.7)	34.4 (10.5)
	Moisture Removal	Pint/h (L/h)	70 (1.39)	35 (0.69)	74 (1.47)	87 (1.72)	128 (2.54)
	Field Drain Pipe Size O.D.	in (mm)	0.625 (16)	0.625 (16)	0.625 (16)	0.625 (16)	0.625 (16)

* Performance may vary based on the outdoor unit it is matched to. See the compatible outdoor units pages for performance data.

COMPATIBILITY

Indoor Unit	DLFSHBH12XAJ	DLFSHBH09XAK	DLFSHBH12XAK	DLFSHBH18XAK	DLFSHBH24XAK
Outdoor Unit Single Zone	DLCSRBH12AAJ	DLCSRBH09AAK	DLCSRBH12AAK	DLCSRBH18AAK	DLCSRBH24AAK
Outdoor Unit Multi-zone		DLCMRAH18BAK			
		DLCMRAH27CAK			
		DLCMRAH36DAK			
		DLCMRAH48EAK			

APPLICATION DATA

Unit Selection

Select equipment that either matches or is supports slightly more than the anticipated peak load. This provides better humidity control, fewer unit cycles, and less part-load operation.

For units used in spaces with high sensible loads, base equipment selection on unit sensible load, not on total anticipated load. Adjust for anticipated room wet bulb temperature to avoid undersizing the equipment.

Unit Mounting (Indoor)

Refer to the unit's installation instructions for further details.

Unit leveling - For reliable operation, units should be level in all planes.

Clearance - Provide adequate clearance for airflow. See Fig. 3 — on page 5.

Unit location - Select a location which provides the best air circulation for the room. These units should be positioned as high as possible on the wall for the best air circulation. The unit return and discharge should not be obstructed by furniture, curtains, or anything which may cause unit short cycling or air recirculation. Place the unit in the middle of the selected wall (if possible). Use an outside wall, if available, to make piping easier, and place the unit so it faces the normal location of room occupants.

Unit Mounting (Outdoor)

Refer to the unit's installation instructions for further details. Do not install the indoor or outdoor units in a location with special environmental conditions. For those applications, contact your Carrier representative.

Mounting Template

Refer to the unit's installation instructions for further details. The fan coil units are furnished with mounting to mark the location of the wiring, and the refrigeration line hole locations.

Support

Adequate support must be provided to support the weight of all the fan coils. Refer to the *Physical Data* section for fan coil weights, and the base unit dimensional drawings for the mounting bracket locations.

System Operating Conditions

OPERATING RANGE MIN/MAX °F / °C		
	COOLING	HEATING
INDOOR DB	62 / 90 (17 / 32)	32 / 86 (0 / 30)
INDOOR WB	57 / 68 (14 / 20)	

NOTE: Reference the product installation instructions for more information.

WIRING

All wires must be sized per NEC (National Electrical Code) or CEC (Canadian Electrical Code) and local codes. Use Electrical Data table MCA (minimum circuit amps) and MOCP (maximum over current protection) to correctly size the wires and the disconnect fuse or breakers respectively.

Recommended Connection Method for Power and Communication Wiring:

The main power is supplied to the outdoor unit. The field supplied 14/3 stranded wire with ground with a 600 volt insulation rating, power/communication wiring from the outdoor unit to indoor unit consists of four (4) wires and provides the power for the indoor unit.

Two wires are line voltage AC power, one is communication wiring (S) and the other is a ground wire. Wiring between indoor and outdoor unit is polarity sensitive. The use of BX wire is NOT recommended.

If installed in a high Electromagnetic field (EMF) area and communication issues exists, a 14/2 stranded shielded wire can be used to replace L2/N and (S) between outdoor unit and indoor unit landing the shield onto ground in the outdoor unit only.

 **CAUTION**

EQUIPMENT DAMAGE HAZARD

Failure to follow this caution may result in equipment damage or improper operation.

Wires should be sized based on NEC and local codes.

 **CAUTION**

EQUIPMENT DAMAGE HAZARD

Failure to follow this caution may result in equipment damage or improper operation.

Be sure to comply with local codes while running wire from the indoor unit to the outdoor unit.

Every wire must be connected firmly. Loose wiring may cause the terminal to overheat or result in unit malfunction. A fire hazard may also exist. Ensure all wiring is tightly connected.

No wire should touch the refrigerant tubing, compressor or any moving parts.

Disconnecting means must be provided and shall be located within sight and readily accessible from the air conditioner.

Connecting cable with conduit shall be routed through the hole in the conduit panel.

DRAIN CONNECTIONS

Install drains to meet the local sanitation codes. If adequate gravity drainage cannot be provided, the unit should be equipped with an accessory condensate pump. The high wall fan coil unit condensate pumps have a maximum lift of 10' (3.05m) for 9k and 12k units and 25' (7.62m) for 18k and 30k units. See the physical dimension tables for the drain sizes.

NOTE: High wall fan coil units have internal condensate traps. A trap is not required.

Drain connections can be routed through alternate locations on most fan coils (see Fig. 4).

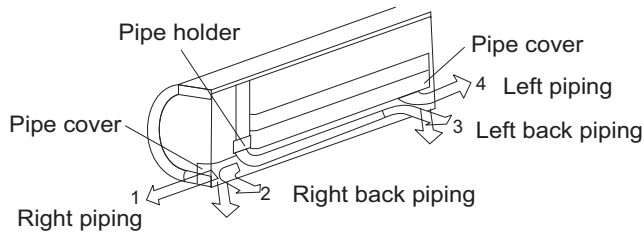

Fig. 4 — Piping Locations

CONTROL SYSTEM

The indoor unit is equipped with a microprocessor control to perform two functions:

1. Provide safety for the system
2. Control the system and provide optimum levels of comfort and efficiency.

The main microprocessor is located on the control board of the fan coil unit (outdoor units also have a microprocessor) with thermistors located in the fan coil air inlet and on the indoor coil. Heat pump units have a thermistor on the outdoor coil. These thermistors monitor the system operation to maintain the unit within acceptable parameters and controls the operating mode.

WIRELESS REMOTE CONTROLLER



Fig. 5 — Wireless Remote Controller

1. A wireless remote control is supplied for system operation for system operation of all high wall units.
2. Each battery operated wireless (infrared)

WIRED REMOTE CONTROLLER (OPTIONAL)

1. Optional wired remote controller used for system operation of all high wall units.
2. Kit includes a wired remote controller and a connecting cable.

NOTE: Extension wire available through RCD.

3. Connect with wire terminal between the remote controller and the indoor unit.
4. Display in °F or °C and temperature increments every 1°F or every 1°C.



Fig. 6 — Wired Remote Controller

24V INTERFACE (OPTIONAL)

Allows a third party thermostat to control the ductless system.

WI-FI KIT FOR SMART PHONE CONTROL (OPTIONAL)

Allows a connected smart phone application to control the ductless system.

AIR FLOW DATA

DLFSHB SYSTEM SIZE		12K (115 V)	9K (208/230 V)	12K (208/230 V)	18K (208/230 V)	24K (208/230 V)
Indoor (CFM)	Turbo	341.18	341.18	341.18	760.59	760.59
	High	300.00	291.18	291.18	530.59	601.18
	Medium	241.18	194.12	194.12	458.82	458.82
	Low	176.47	152.94	152.94	382.35	382.35

AIR THROW DATA

HIGH WALL UNIT CAPACITY	MAX. APPROXIMATE AIR THROW FT. (M)
12K (115)	23(7)
9K (230)	19.7(6)
12K (230)	22.3(6.8)
18K (230)	31.8(9.7)
24K (230)	34.4(10.5)

AIR MOISTURE

SIZE		12K	9K	12K	18K	24K
Voltage, Phase, Cycle	V/Ph/Hz	115-1-60	208/230-1-60	208/230-1-60	208/230-1-60	208/230-1-60
Dehumidifying Volume	L/h	1.39	0.69	1.47	1.72	2.54
Dehumidifying Volume	PINT/D	70	35	74	87	128

SOUND PRESSURE

HIGH WALLS INDOOR		12K (115 V)	9K (208/230 V)	12K (208/230 V)	18K (208/230 V)	24K (208/230 V)
Cooling Operation Indoor	dB(A) at (Turbo/High(100%) / Med(60%) /Low(40%) CFM)	41.7/37.1/34.8	39.5/34.6/32.4	42.5/36.7/34	45.1/39.8/37.4	47.5/41.3/37.6
Heating Operation Indoor Sound Pressure	dB(A) at (Turbo/High(100%) / Med(60%) /Low(40%) CFM)	38.6/32.3/29.8	41.2/35.5/32.3	41/35.6/32.9	46.3/40.9/37.9	49.8/45.1/41

FAN AND MOTOR SPECIFICATIONS

HIGH WALL UNIT SIZE			12K	9K	12K	18K	24K
			(115 V)	(208/230 V)	(208/230 V)	(208/230 V)	(208/230 V)
High Wall Fan	Material		Acrylontrile Styrene +30%GF	Acrylontrile Styrene +30%GF	Acrylontrile Styrene +30%GF	Acrylontrile Styrene +30%GF	Acrylontrile Styrene +30%GF
	Type		GL-96*608-IN	GL-96*608-IN	GL-96*608-IN	GL-108*818	GL-108*818
	Diameter	In (mm)	3.78(96)	3.78(96)	3.78(96)	4.25(108)	4.25(108)
	Height	In (mm)	23.94(608)	23.94(608)	23.94(608)	32.2(818)	32.2(818)
High Wall fan Motor	Model		ZKFP-20-8-113	ZKFP-13-8-4	ZKFP-13-8-4	ZKFP-58-8-1-5	ZKFP-58-8-1-5
	Volts	V	140	310	310	310	310
	Phase		1	1	1	1	1
	FLA	A	0.25	0.15	0.15	0.4	0.4
	MCA	A	0.31	0.19	0.19	0.5	0.5
	Type		DC				
	Insulation class		E	E	E	E	E
	Safe class		IP20(Welling, Dayang)/ IPX0(Tongda)	IPX0	IPX0	IP20	IP20
	Input	W	65.8 (Welling, Tongda)/ 68(Dayang)	36.8	36.8	64.1	64.1
	Output	W	20	13	13	58	58
	Range of current	Amps	0.467±10% (Welling, Tongda)/ 0.486±10% (Dayang)	0.34±10%	0.34±10%	0.21±10%	0.21±10%
	Rated current	Amps	0.467 (Welling, Tongda)/ 0.486(Dayang)	0.34	0.34	0.21	0.21
	Capacitor	μF	NA	NA	NA	NA	NA
	Rated HP	HP	0.027	0.017	0.017	0.077	0.077
Speed	rev/min	850/750/450	1150/990/750	1250/990/750	1120/952/868	1200/960/600	
Rated RPM	rev/min	850	1150	1250	1120	1200	
Max. input	W	65.8	36.8	36.8	58	58	

NOTE: Refer to the outdoor unit installation instructions (indoor unit powered by the outdoor unit).

WIRING DIAGRAMS

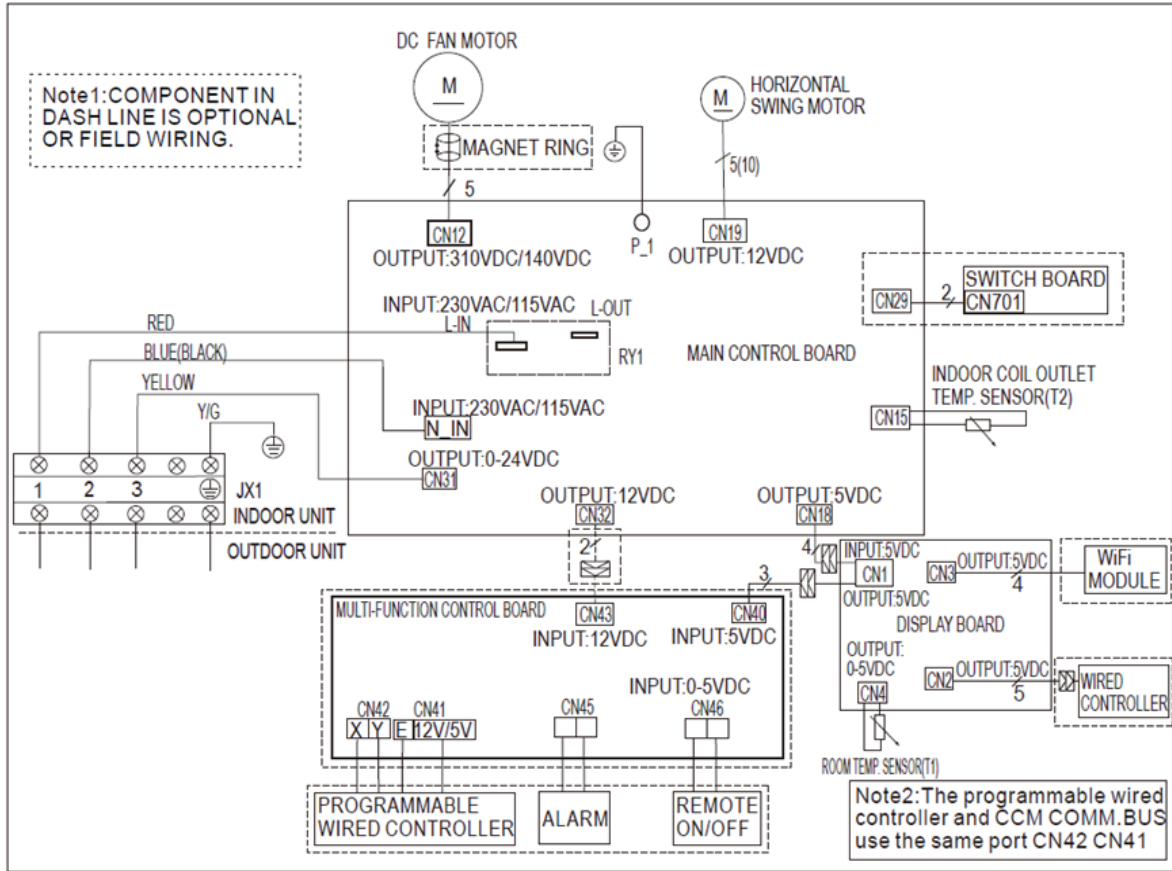

Fig. 7 — Wiring Diagram Sizes 9K - 12K (208/230V)

WIRING DIAGRAMS (CONT)

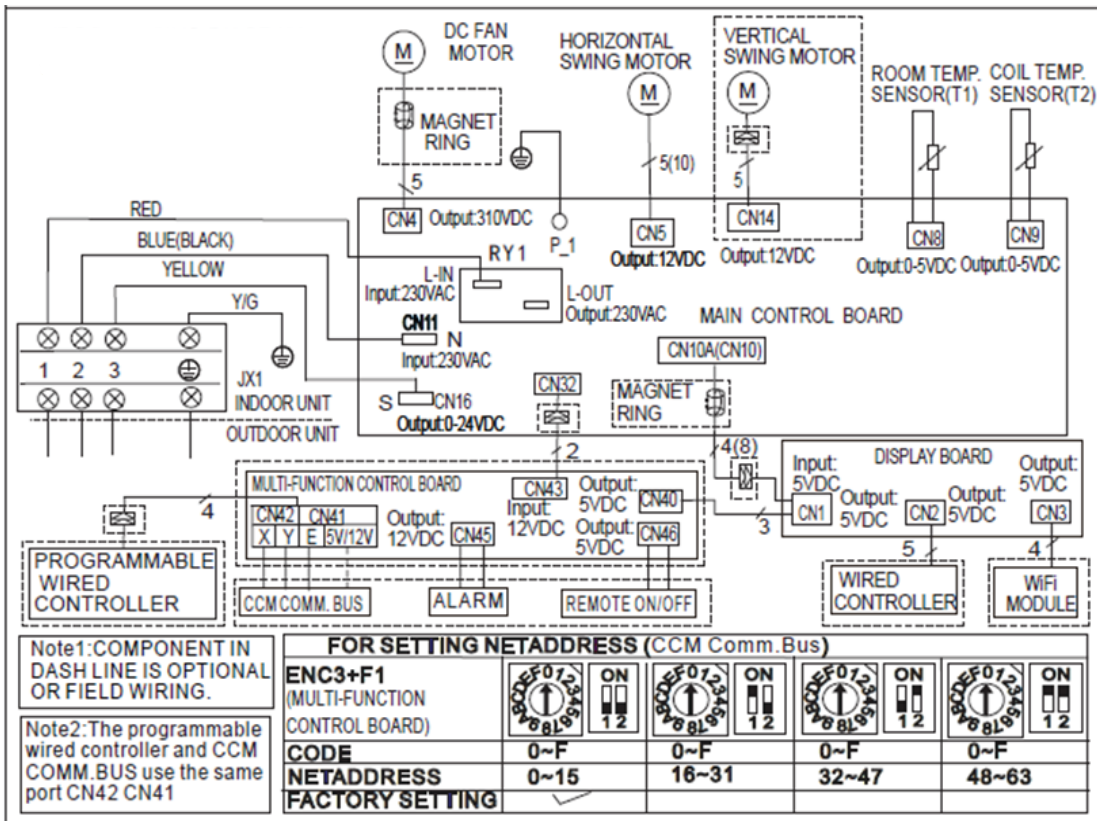

Fig. 8 — Wiring Diagram Sizes 18K - 24K (208/230V)

GUIDE SPECIFICATIONS

INDOOR WALL-MOUNTED DUCTLESS UNITS

Size Range: 1/2 to 2 Ton Nominal Cooling and Heating Capacity
Model Number: **DLFSHB**

Part 1 - GENERAL

1.01 System Description

Indoor, wall-mounted, direct-expansion fan coils are matched with the heat pump outdoor unit.

1.02 Agency Listings

Unit are rated per AHRI Standards 210/240 and listed in the AHRI directory as a matched system.

1.03 Delivery, Storage, And Handling

Units are stored and handled per the unit manufacturer's recommendations.

1.04 Warranty (For Inclusion By Specifying Engineer)

Part 2 - PRODUCTS

2.01 Equipment

A. General: Indoor, direct-expansion, wall-mounted fan coil

Unit is complete with a cooling/heating coil, fan, fan motor, piping connectors, electrical controls, microprocessor control system, and integral temperature sensing. Unit is furnished with an integral wall mounting bracket and mounting hardware.

B. Unit Cabinet:

Cabinet discharge and inlet grilles are attractively styled, high-impact polystyrene. Cabinet is fully insulated for improved thermal and acoustic performance.

C. Fans:

1. Fan is the tangential direct-drive blower type with air intake at the top of the unit and discharge at the bottom front. An automatic, motor-driven vertical and horizontal air sweep is provided as standard equipment.
2. The air sweep operation is user selectable. The vertical and horizontal sweep may be adjusted (using the remote control).

D. Coil:

The coil is a copper tube with aluminum fins and galvanized steel tube sheets. The fins are bonded to the tubes by mechanical expansion and anti-corrosive fin coating. A drip pan under the coil has a drain connection for the hose attachment to remove condensate. The condensate pan has an internal trap.

E. Motors:

Motors are open drip-proof, with a permanently lubricated ball bearing. The fan motors is 3-speed.

F. Controls:

Controls consist of a microprocessor-based control system which controls space temperature, determine optimum fan speed, and run self diagnostics. The temperature control range is from 62°F to 86°F (17°C to 30°C) in increments of 1°F or 1°C, and have 46°F Heating Mode (Heating Setback). The wireless remote controller has the ability to act as the temperature sensing location for room comfort.

The unit has the following functions as a minimum:

1. An automatic restart after a power failure at the same operating conditions as at the failure.
2. A timer function to provide a minimum 24-hour timer cycle for system Auto Start/Stop.
3. Temperature-sensing controls sense return air temperature.
4. Indoor coil freeze protection.
5. Wireless infrared remote control to enter set points and operating conditions.
6. Automatic air sweep control to provide on or off activation of air sweep louvers.
7. Dehumidification mode provides increased latent removal capability by modulating the system operation and the set point temperature using Relative Humidity percentage control.
8. Fan-only operation to provide room air circulation when no cooling is required.
9. Diagnostics provide continuous checks of unit operation and warn of possible malfunctions. Error messages appear on the unit.
10. Fan speed control is user-selectable: turbo, high, medium, low, or microprocessor controlled automatic operation during all operating modes.
11. Automatic heating-to-cooling changeover in the heat pump mode. Control includes deadband to prevent rapid mode cycling between heating and cooling.
12. Indoor coil high temperature protection detects excessive indoor discharge temperature when the unit is in the heat pump mode.

G. Filters:

Unit have a filter track located at the top of the unit with factory-supplied cleanable filters for easy cleaning.

H. Electrical Requirements:

Indoor fan motor to operate on 115V on model size 12 and on 208-230V on model sizes 06-36, as specified. Power is supplied by the outdoor unit..

I. Operating Characteristics:

The **DLFSHB** system has a minimum SEER (Seasonal Energy Efficiency Ratio) and HSPF at AHRI conditions, as listed on the specifications table.

J. Refrigerant Lines:

All units have refrigerant lines that can be oriented to connect from the left, right or back of unit. Both refrigerant lines need to be insulated.

K. Special Features (Field Installed):

Condensate Pump:

The condensate pump removes condensate from the drain pan when gravity drainage cannot be used. The pump is designed for quiet operation. The pump consists of two parts: an internal reservoir/sensor assembly, and a remote sound-shielded pump assembly. A liquid level sensor in the reservoir stops the cooling operation if the liquid level in the reservoir is unacceptable.

Wi-Fi Compatible

BACNet Compatible

