

Visit [www.carrier.com](http://www.carrier.com)

# Installation, Start-Up, and Operating Instructions

## For Sizes 040—120, Series 140 and 150

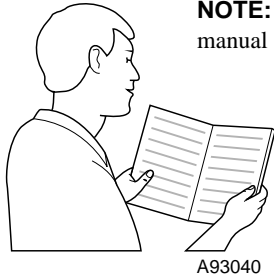

**NOTE:** Read the entire instruction manual before starting the installation.



As an ENERGY STAR® Partner, Carrier Corporation has determined that this product meets the ENERGY STAR® guidelines for energy efficiency.

REGISTERED QUALITY SYSTEM

This symbol → indicates a change since the last issue.

Index	Page
DIMENSIONAL DRAWING	3
SAFETY CONSIDERATIONS	2
Clearances to Combustibles	4
ELECTROSTATIC DISCHARGE (ESD) PRECAUTIONS	2
INTRODUCTION	2-4
APPLICATIONS	5-11
General	5
Upflow Applications	5-7
Downflow Applications	7-8
Horizontal Left (Supply-Air Discharge) Applications	8-10
Horizontal Right (Supply-Air Discharge) Applications	10-11
LOCATION	11-13
General	11-12
Low-Fire Only Installation	13
Furnace Location Relative to Cooling Equipment	13
Hazardous Locations	13
INSTALLATION	13-14
Leveling Legs (If Desired)	13
Installation In Upflow or Downflow Applications	14-15
Installation In Horizontal Applications	14
AIR DUCTS	14-18
General Requirements	14
Ductwork Acoustical Treatment	14
Supply-Air Connections	14
Return-Air Connections	14
Filter Arrangement	16-17
Bottom Closure Panel	17
Gas Piping	17-18
ELECTRICAL CONNECTIONS	18-22
115-v Wiring	18-19
24-v Wiring	19
Accessories	21-22
DIRECT VENTING	22-31
Removal of Existing Furnaces from	
Common Vent Systems	23
Combustion-Air and Vent Piping	23
Concentric Vent and Combustion-Air Termination	
Kit Installation	28-31
Multiventing and Vent Terminations	31
CONDENSATE DRAIN	31-33
General	31-32

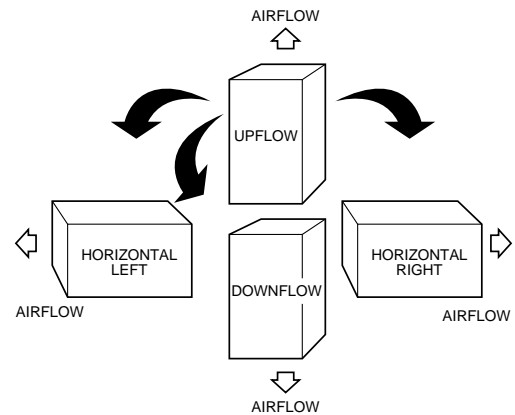

**Fig. 1—Multipoise Orientations**

A93041

Application	31
Condensate Drain Protection	31
SEQUENCE OF OPERATION	33-36
Self-Test Mode	33
Heating Mode	33
Heating Mode—Two Stage	34
Emergency Heat Mode	34
Cooling Mode	34
Heat Pump Mode	34-35
Continuous Fan Mode	35-36
Component Test	36
Bypass Humidifier Mode	36
Dehumidification Mode	36
Zone Mode	36
START-UP PROCEDURES	36-45
General	36
Select Setup Switch Positions	37
Prime Condensate Trap With Water	37
Purge Gas Lines	38
Adjustments	38-45
Set Gas Input Rate	38-44
Set Temperature Rise	44

Manufacturer reserves the right to discontinue, or change at any time, specifications or designs without notice and without incurring obligations.

Set Thermostat Heat Anticipator.....45  
CHECK SAFETY CONTROLS.....45  
Check Primary Limit Control.....45  
Check Pressure Switch .....45  
CHECKLIST .....45

**SAFETY CONSIDERATIONS**

Installing and servicing heating equipment can be hazardous due to gas and electrical components. Only trained and qualified personnel should install, repair, or service heating equipment. Untrained personnel can perform basic maintenance functions such as cleaning and replacing air filters. All other operations must be performed by trained service personnel. When working on heating equipment, observe precautions in literature, on tags, and on labels attached to or shipped with unit and other safety precautions that may apply.

Follow all safety codes. In the United States, follow all safety codes including the National Fuel Gas Code (NFGC) NFPA No. 54-1999/ANSI Z223.1-1999 and the Installation Standards, Warm Air Heating and Air Conditioning Systems (NFPA 90B) ANSI/NFPA 90B. In Canada, refer to the current edition of the CAN/CGA-B149.1- and .2-M95 National Standard of Canada, Natural Gas and Propane Installation Codes (NSCNGPIC). Wear safety glasses and work gloves. Have a fire extinguisher available during start-up and adjustment procedures and service calls.

Recognize safety information. This is the safety-alert symbol . When you see this symbol on unit or in instructions and manuals, be alert to potential for personal injury.

Understand the signal words DANGER, WARNING, and CAUTION. These words are used with safety-alert symbol. DANGER identifies the most serious hazards which **will** result in severe personal injury or death. WARNING signifies hazards which **could** result in personal injury or death. CAUTION is used to identify unsafe practices which **would** result in minor personal injury or product and property damage. NOTE is used to highlight suggestions which **will** result in enhanced installation, reliability, or operation.

**ELECTROSTATIC DISCHARGE (ESD) PRECAUTIONS**

** CAUTION**

Electrostatic discharge can affect electronic components. Take precautions during furnace installation and servicing to protect the furnace electronic control. Precautions will prevent electrostatic discharges from personnel and hand tools which are held during the procedure. These precautions will help to avoid exposing the control to electrostatic discharge by putting the furnace, the control, and the person at the same electrostatic potential.

1. Disconnect all power to the furnace. **DO NOT TOUCH THE CONTROL OR ANY WIRE CONNECTED TO THE CONTROL PRIOR TO DISCHARGING YOUR BODY'S ELECTROSTATIC CHARGE TO GROUND.**
2. Firmly touch a clean, unpainted, metal surface of the furnace chassis which is close to the control. Tools held in a person's hand during grounding will be satisfactorily discharged.
3. After touching the chassis you may proceed to service the control or connecting wires as long as you do nothing that recharges your body with static electricity (for example; DO NOT move or shuffle your feet, DO NOT touch ungrounded objects, etc.).
4. If you touch ungrounded objects (recharge your body with static electricity), firmly touch furnace again before touching control or wires.

5. Use this procedure for installed and uninstalled (ungrounded) furnaces.
6. Before removing a new control from its container, discharge your body's electrostatic charge to ground to protect the control from damage. If the control is to be installed in a furnace, follow items 1 through 5 before bringing the control or yourself into contact with the furnace. Put all used AND new controls into containers before touching ungrounded objects.
7. An ESD service kit (available from commercial sources) may also be used to prevent ESD damage.

**INTRODUCTION**

The 58MVP Multipoise Condensing Gas-Fired Furnaces are CSA (A.G.A. and C.G.A.) certified for natural and propane gases and for installation in alcoves, attics, basements, closets, utility rooms, crawlspaces, and garages. The furnace is factory-shipped for use with natural gas. A manufacturer's accessory gas conversion kit is required to convert furnace for use with propane gas.

These furnaces **SHALL NOT** be installed directly on carpeting, tile, or any other combustible material other than wood flooring. In downflow installations, a manufacturer's accessory floor base **MUST** be used when installed on combustible materials and wood flooring. Special base is not required when this furnace is installed on manufacturer's Coil Assembly Part No. CD5 or CK5, or when Coil Box Part No. KCAKC is used. The design of this furnace line is not CSA (A.G.A. and C.G.A.) certified for installation in mobile homes, recreation vehicles, or outdoors. These furnaces are suitable for installation in a residence built on site or a manufactured residence completed at final site.

These furnaces are shipped with the drain and pressure tubes connected for UPFLOW applications. Minor modifications are required when used in DOWNFLOW, HORIZONTAL RIGHT, or HORIZONTAL LEFT (supply-air discharge direction) applications as shown in Fig. 1. See details in Applications section.

These furnaces are shipped with the following materials to assist in proper furnace installation. These materials are shipped in the main blower compartment.

Installer Packet includes:

- Installation, Start-Up, and Operating Instructions
- Service and Maintenance Instructions
- User's Information Manual
- Warranty Certificate

Loose Parts Bag includes:

	Quantity
Pressure tube extension	1
Collector box or condensate trap extension tube	1
Inducer housing drain tube	1
1/2-in. CPVC street elbow	2
Drain tube coupling	1
Drain tube coupling grommet	1
Vent and combustion-air pipe support	2
Combustion-air pipe perforated disk assembly	1
Condensate trap hole filler plug	3
Vent and combustion-air intake hole filler plug	2

This furnace must be installed with a direct-vent (combustion air and flue) system and a factory accessory termination kit. In a direct-vent system, all air for combustion is taken directly from the outside atmosphere and all flue products are discharged to the outside atmosphere. See furnace and factory accessory termination kit instructions for proper installation.

Before installing the furnace in the United States, refer to the current edition of the NFGC and the NFPA 90B. For copies of the NFGC and NFPA 90B, contact the National Fire Protection

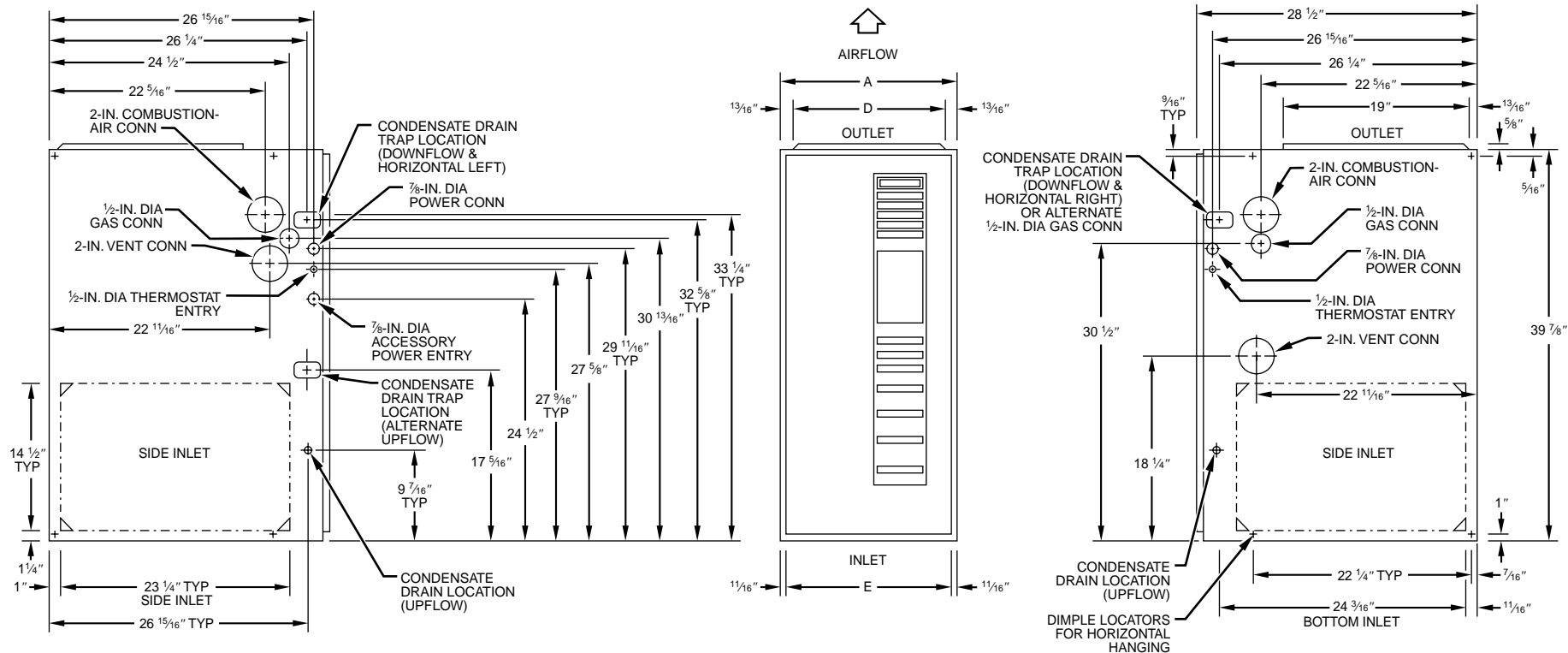

- NOTES:**
- Minimum return-air openings at furnace, based on metal duct. If flex duct is used, see flex duct manufacturer's recommendations for equivalent diameters.
  - Minimum return-air opening at furnace:
    - For 800 CFM—16-in. round or 14 1/2 x 12-in. rectangle.
    - For 1200 CFM—20-in. round or 14 1/2 x 19 1/2-in. rectangle.
    - For 1600 CFM—22-in. round or 14 1/2 x 23 1/4-in. rectangle.
    - For airflow requirements above 1800 CFM, see Air Delivery table in Product Data literature for specific use of single side inlets. The use of both side inlets, a combination of 1 side and the bottom, or the bottom only will ensure adequate return air openings for airflow requirements above 1800 CFM.

**Dimensions (In.)**

UNIT SIZE	A	D	E
040-14*	24-1/2*	22-7/8*	23*
060-14	17-1/2	15-7/8	16
080-14	21	19-3/8	19-1/2
080-20	21	19-3/8	19-1/2
100-20	21	19-3/8	19-1/2
120-20	24-1/2	22-7/8	23

\* These dimensions reflect the wider casing for the Trophy (96.6 percent AFUE) furnace.

**Fig. 2—Dimensional Drawing**

Association Inc., Batterymarch Park, Quincy, MA 02269; or American Gas Association, 1515 Wilson Boulevard, Arlington, VA 22209.

Before installing the furnace in Canada, refer to the current edition of the NSCNPGIC. Contact Standard Sales CSA International, 178 Rexdale Boulevard, Etobicoke, (Toronto) Ontario, Canada M9W 1R3.

Installation must comply with regulations of serving gas supplier and local building, heating, plumbing or other codes in effect in the area in which installation is made. In absence of local codes, installation must comply with the NFGC in the United States and the NSCNPGIC in Canada.

These instructions cover minimum requirements for a safe installation and conform to existing national standards and safety codes. In some instances, these instructions exceed certain local codes and ordinances, especially those that may not have kept pace with changing residential construction practices. We require these instructions as a minimum for a safe installation.

**CAUTION**  
Application of this furnace should be indoors with special attention given to vent sizing and material, gas input rate, air temperature rise, unit leveling, and unit sizing. Improper installation or misapplication of furnace can require excessive servicing or cause premature component failure.

**WARNING**  
Improper installation, adjustment, alteration, service, maintenance, or use can cause carbon monoxide poisoning, explosion, fire, electrical shock, or other conditions which may cause personal injury or property damage. Consult a qualified installer, service agency, local gas supplier, or your distributor or branch for information or assistance. The qualified installer or agency must use only factory-authorized and listed kits or accessories when modifying this product. Failure to follow this warning could result in electrical shock, fire, personal injury, or death.

For accessory installation details, refer to applicable installation literature.

## INSTALLATION

This forced air furnace is equipped for use with natural gas at altitudes 0 - 10,000 ft (0 - 3,050m).  
An accessory kit, supplied by the manufacturer, shall be used to convert to propane gas use or may be required for some natural gas applications.

This furnace is for indoor installation in a building constructed on site. This furnace may be installed in a manufactured (mobile) home when stated on rating plate and using factory authorized kit.

This furnace may be installed on combustible flooring in alcove or closet at minimum clearance from combustible material.

This appliance requires a special venting system. Refer to the installation instructions for parts list and method of installation. This furnace is for use with schedule-40 PVC, PVC-DWV, or ABS-DWV pipe, and must not be vented in common with other gas-fired appliances. Construction through which vent/air intake pipes may be installed is maximum 24 inches (600 mm), minimum 3/4 inches (19 mm) thickness (including roofing materials).

---

Furnace must be installed level, or pitched forward within 1/2 inch of level for proper drainage. Failure will result in equipment or property damage. See Installation Manual for IMPORTANT unit support details on horizontal applications.

---

### MINIMUM INCHES CLEARANCE TO COMBUSTIBLE CONSTRUCTION

**ALL POSITIONS:**  
\* Minimum front clearance for service 30 inches (762mm).

**DOWNFLOW POSITIONS:**  
† For installation on combustible floors only when installed on special base No. KGASB0201ALL, Coil Assembly, Part No. CD5 or CK5, or Coil Casing, Part No. KCAKC.

**HORIZONTAL POSITIONS:**  
§ Clearance shown is for air inlet and air outlet end. Line contact is permissible only between lines formed by intersections of top and two sides of furnace jacket, and building joists, studs, or framing.  
∅ 120 size Furnace require 1 inch bottom clearance to combustible materials.

325400-201 REV. A  
(LIT. TOP)

This furnace is approved for UPFLOW, DOWNFLOW and HORIZONTAL installations.

Clearance arrows do not change with furnace orientation.

Clearance in inches.

Vent clearance to combustibles 0".

Fig. 3—Clearances to Combustibles

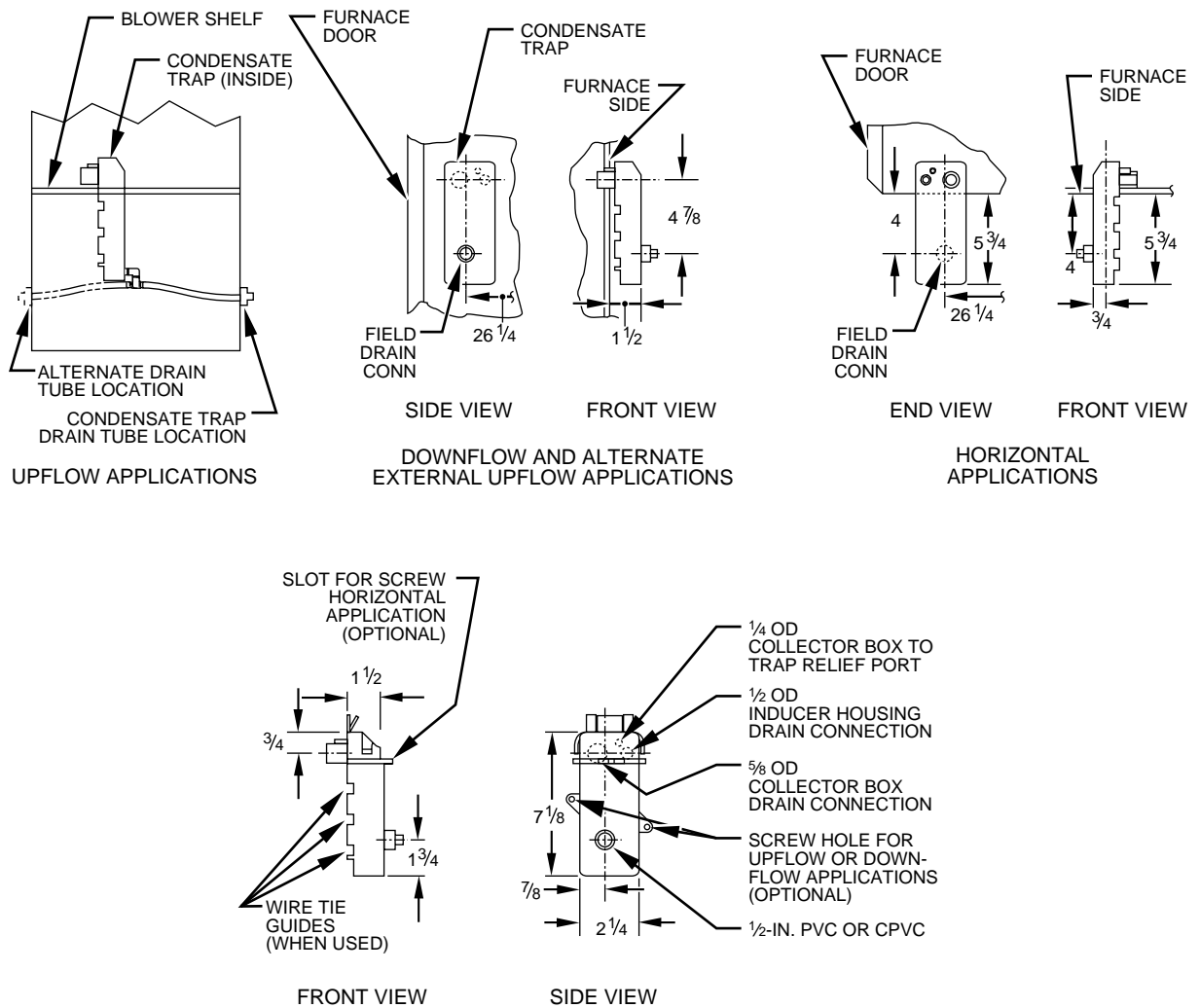

Fig. 4—Condensate Trap

A93026

**APPLICATIONS**

**Step 1—General**

Some assembly and modifications are required for furnaces installed in any of the 4 applications shown in Fig. 1. All drain and pressure tubes are connected as shown in Fig. 5. See appropriate application instructions for these procedures.

**Step 2—Upflow Applications**

An upflow furnace application is where furnace blower is located below combustion and controls section of furnace, and conditioned air is discharged upwards.

**CONDENSATE TRAP LOCATION (FACTORY-SHIPPED ORIENTATION)**

The condensate trap is factory installed in the blower shelf and factory connected for UPFLOW applications. A factory-supplied tube is used to extend the condensate trap drain connection to the desired furnace side for field drain attachment. See Condensate Trap Tubing (Factory-Shipped Orientation) section for drain tube extension details.

**CONDENSATE TRAP TUBING (FACTORY-SHIPPED ORIENTATION)**

**NOTE:** See Fig. 5 or tube routing label on main furnace door to confirm location of these tubes.

1. Collector Box Drain, Inducer Housing Drain, Relief Port, and Pressure Switch Tubes

These tubes should be factory attached to condensate trap and pressure switch ready for use in UPFLOW applications. These tubes can be identified by their connection location and also by a color label on each tube. These tubes are identified as follows: collector box drain tube (blue label), inducer housing drain tube (violet label or molded), relief port tube (green label), and pressure switch tube (pink label).

**2. Condensate Trap Drain Tube**

The condensate trap drain connection must be extended for field attachment by doing the following:

- a. Determine location of field drain connection. (See Fig. 2 or 5.)

**NOTE:** If internal filter or side filter/media cabinet is used, drain tube should be located to opposite side of casing of return duct attachment to assist in filter removal.

- b. Remove and discard casing drain hole plug button from desired side.
- c. Install drain tube coupling grommet (factory-supplied in loose parts bag) in selected casing hole.
- d. Slide drain tube coupling (factory-supplied in loose parts bag) through grommet so long end of coupling faces blower.

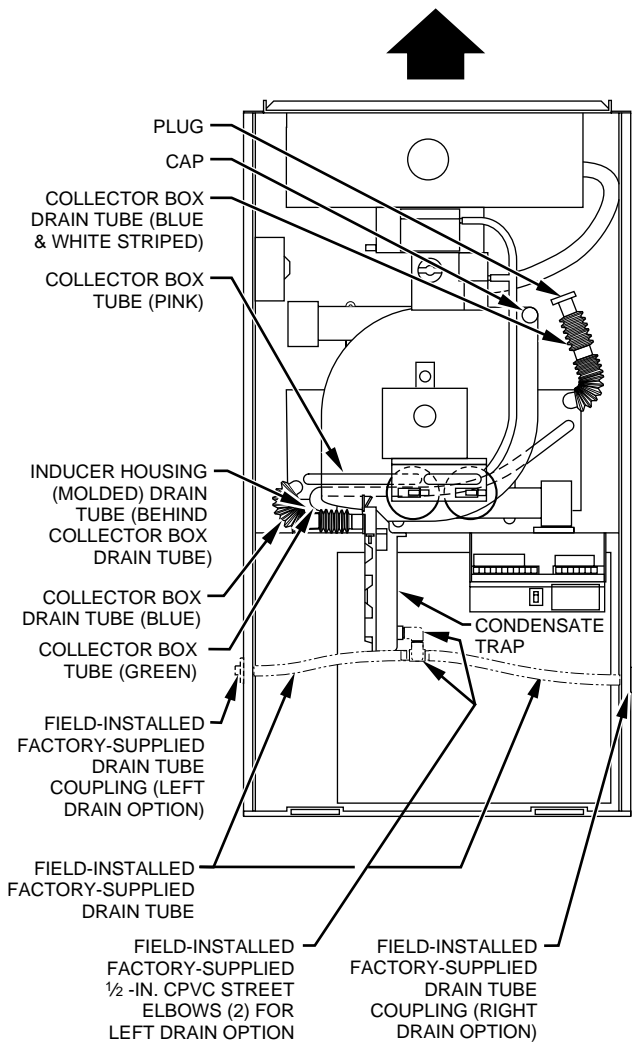

A94213

**Fig. 5—Factory-Shipped Upflow Tube Configuration (Shown With Blower Access Panel Removed)**

- e. Cement 2 factory-supplied 1/2-in. street CPVC elbows to rigid drain tube connection on condensate trap. (See Fig. 5.) These elbows must be cemented together and cemented to condensate trap drain connection.

**NOTE:** Failure to use CPVC elbows may allow drain to kink, preventing draining.

- f. Connect larger diameter drain tube and clamp (factory-supplied in loose parts bag) to condensate trap and clamp securely.
- g. Route tube to coupling and cut to appropriate length.
- h. Attach tube to coupling and clamp securely.

**CONDENSATE TRAP LOCATION (ALTERNATE UPFLOW ORIENTATION)**

An alternate location for the condensate trap is the left-hand side of casing. (See Fig. 2 and 6.)

**NOTE:** If the alternate left-hand side of casing location is used, the factory-connected drain and relief port tubes must be disconnected and modified for attachment. See Condensate Trap Tubing (Alternate Upflow Orientation) section for tubing attachment.

To relocate condensate trap to the left-hand side, perform the following:

1. Remove 3 tubes connected to condensate trap.

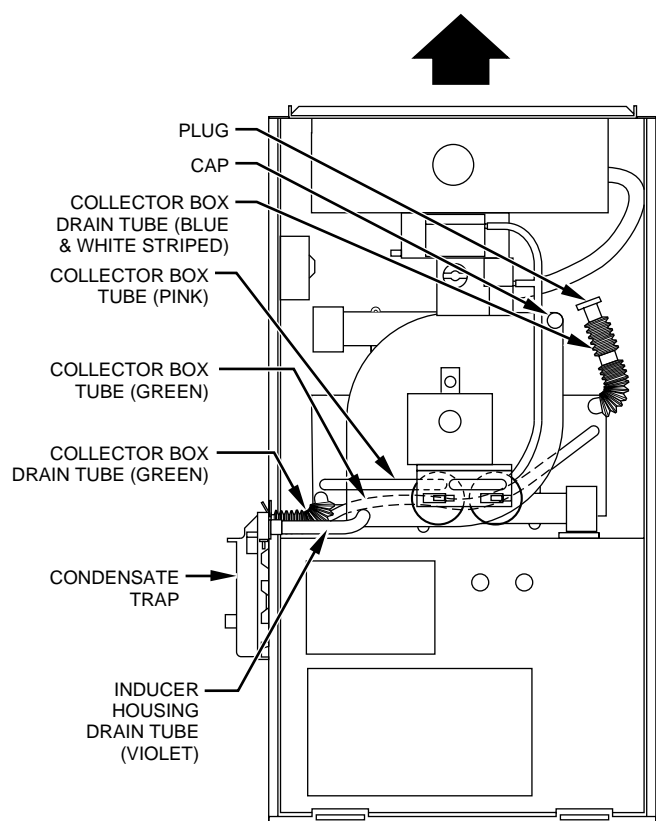

A94214

**Fig. 6—Alternate Upflow Tube Configuration and Trap Location**

2. Remove trap from blower shelf by gently pushing tabs inward and rotating trap.
3. Install casing hole filler cap (factory-supplied in loose parts bag) into blower shelf hole where trap was removed.
4. Install casing hole filler cap into blower shelf hole where trap was removed.
5. Fill unused condensate trap casing holes with plastic filler caps (factory-supplied in loose parts bag).

**CONDENSATE TRAP TUBING (ALTERNATE UPFLOW ORIENTATION)**

**NOTE:** See Fig. 6 or tube routing label on main furnace door to confirm location of these tubes.

1. Collector Box Drain Tube  
Connect collector box drain tube (blue label) to condensate trap.

**NOTE:** On 17-1/2-in. wide furnaces ONLY, cut tube between corrugated sections to prevent kinks.

2. Inducer Housing Drain Tube
  - a. Remove and discard LOWER (molded) inducer housing drain tube which was previously connected to condensate trap.

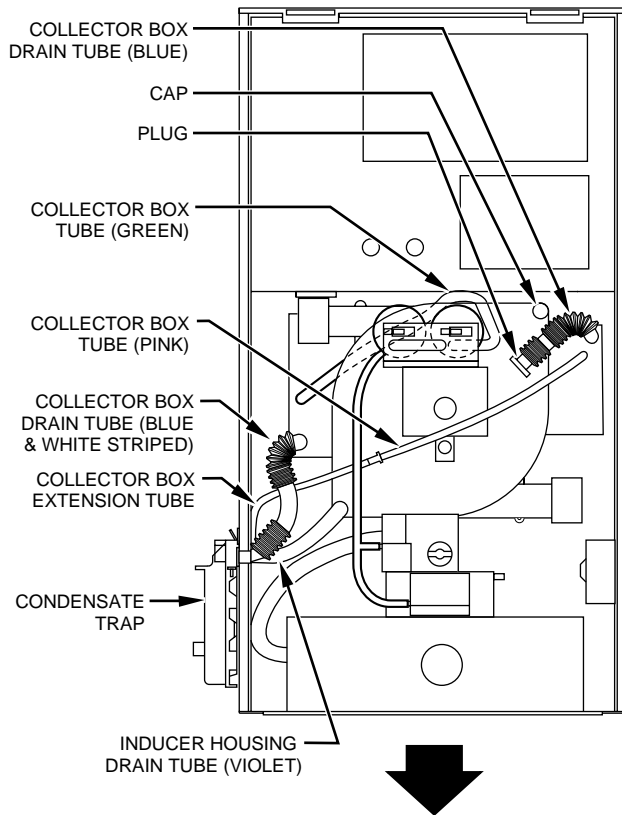

**Fig. 7—Downflow Tube Configuration (Left-Hand Trap Installation)**

A94215

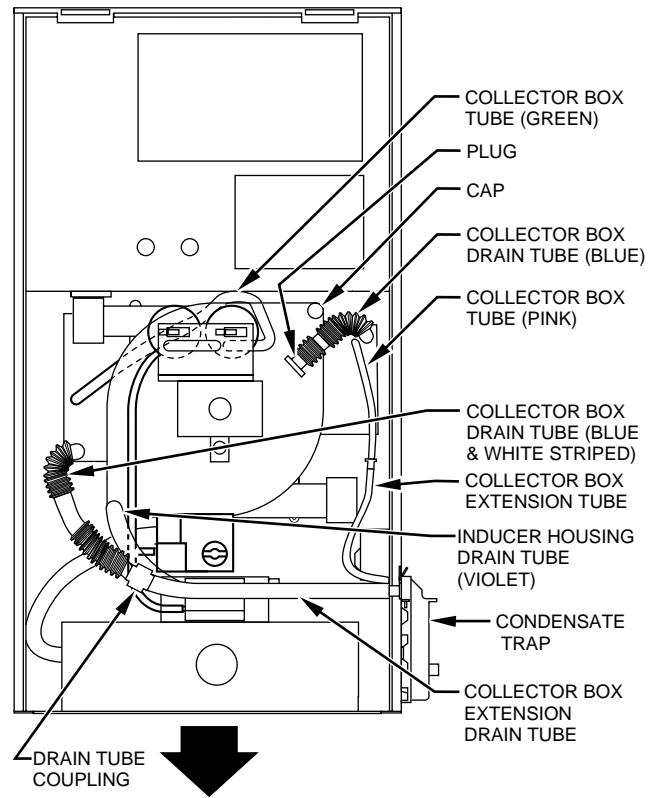

**Fig. 8—Downflow Tube Configuration (Right-Hand Trap Installation)**

A94216

- b. Use inducer housing drain extension tube (violet label and factory-supplied in loose parts bag) to connect LOWER inducer housing drain connection to condensate trap.
  - c. Determine appropriate length, cut, and connect tube.
  - d. Clamp tube to prevent any condensate leakage.
3. Relief Port Tube
- a. Connect relief port tube (green label) to condensate trap.
  - b. Extend this tube (if required) by splicing to small diameter tube (factory-supplied in loose parts bag).
  - c. Determine appropriate length, cut, and connect tube.

#### CONDENSATE TRAP FIELD DRAIN ATTACHMENT

Refer to Condensate Drain section for recommendations and procedures.

#### PRESSURE SWITCH TUBING

The LOWER collector box pressure tube (pink label) is factory connected to the pressure switch and should not require any modification.

**NOTE:** See Fig. 5 or 6 or tube routing label on main furnace door to check for proper connections.

#### UPPER COLLECTOR BOX AND INDUCER HOUSING (UNUSED) DRAIN CONNECTIONS

##### Upper Collector Box Drain Connection

Attached to the UPPER collector box drain connection is a factory-installed corrugated, plugged tube (blue and white striped label). This tube is plugged to prevent condensate leakage in this application. Ensure this tube is plugged.

**NOTE:** See Fig. 5 or 6 or tube routing label on main furnace door to check for proper connections.

#### Upper Inducer Housing Drain Connection

Attached to the UPPER (unused) inducer housing drain connection is a cap and clamp. This cap is used to prevent condensate leakage in this application. Ensure this connection is capped.

**NOTE:** See Fig. 5 or 6 or tube routing label on main furnace door to check for proper connections.

#### CONDENSATE TRAP FREEZE PROTECTION

Refer to Condensate Drain Protection section for recommendations and procedures.

#### Step 3—Downflow Applications

A downflow furnace application is where furnace blower is located above combustion and controls section of furnace, and conditioned air is discharged downwards.

#### CONDENSATE TRAP LOCATION

The condensate trap must be removed from the factory-installed blower shelf location and relocated in selected application location as shown in Fig. 2, 7, or 8.

To relocate condensate trap from the blower shelf to desired location, perform the following:

1. Remove 3 tubes connected to condensate trap.
2. Remove trap from blower shelf by gently pushing tabs inward and rotating trap.
3. Install casing hole filler cap (factory-supplied in loose parts bag) into blower shelf hole where trap was removed.
4. Install casing hole filler cap into blower shelf hole where trap was removed.
5. Fill unused condensate trap casing holes with plastic filler caps (factory-supplied in loose parts bag).

## CONDENSATE TRAP TUBING

**NOTE:** See Fig. 7 or 8 or tube routing label on main furnace door to check for proper connections.

### 1. Collector Box Drain Tube

- a. Remove factory-installed plug from LOWER collector box drain tube (blue and white striped label).
- b. Install removed clamp and plug into UPPER collector box drain tube (blue label) which was connected to condensate trap.
- c. Connect LOWER collector box drain connection to condensate trap.

#### (1.) Condensate Trap Located on Left Side of Casing

- (a.) Connect LOWER collector box drain tube (blue and white striped label) to condensate trap. Tube does not need to be cut.
- (b.) Clamp tube to prevent any condensate leakage.

#### (2.) Condensate Trap Located on Right Side of Casing

- (a.) Install drain tube coupling (factory-supplied in loose parts bag) into collector box drain tube (blue and white striped label) which was previously plugged.
- (b.) Connect larger diameter drain tube (factory-supplied in loose parts bag) to drain tube coupling, extending collector box drain tube for connection to condensate trap.
- (c.) Route extended collector box drain tube between gas valve and inlet housing as shown in Fig. 8.
- (d.) Determine appropriate length and cut.
- (e.) Connect to condensate trap.
- (f.) Clamp tube to prevent any condensate leakage.

### 2. Inducer Housing Drain Tube

- a. Remove factory-installed cap and clamp from LOWER inducer housing drain connection.
- b. Remove and discard UPPER (molded) inducer housing drain tube which was previously connected to condensate trap.
- c. Install cap and clamp on UPPER inducer housing drain connection where molded drain tube was removed.
- d. Use inducer housing drain tube (violet label and factory-supplied in loose parts bag) to connect LOWER inducer housing drain connection to the condensate trap.
- e. Connect inducer housing drain connection to condensate trap.

#### (1.) Condensate Trap Located on Left Side of Casing

- (a.) Determine appropriate length and cut.
- (b.) Connect tube to condensate trap.
- (c.) Clamp tube to prevent any condensate leakage.

#### (2.) Condensate Trap Located on Right Side of Casing

- (a.) Route inducer housing drain tube (violet label) directly from collector box drain to condensate trap.
- (b.) Determine appropriate length and cut.
- (c.) Connect tube to condensate trap.
- (d.) Clamp tube to prevent any condensate leakage.

### 3. Relief Port Tube

Refer to Pressure Switch Tubing section for connection procedure.

## CONDENSATE TRAP FIELD DRAIN ATTACHMENT

Refer to Condensate Drain section for recommendations and procedures.

## PRESSURE SWITCH TUBING

One collector box pressure tube (pink label) is factory connected to the pressure switch for use when furnace is installed in UPFLOW or HORIZONTAL LEFT applications. This tube **MUST** be disconnected and used for the condensate trap relief port tube. The other collector box pressure tube (green label) which was factory connected to the condensate trap relief port connection **MUST** be connected to the pressure switch in DOWNFLOW or HORIZONTAL RIGHT applications.

**NOTE:** See Fig. 7 or 8 or tube routing label on main furnace door to check for proper connections.

Relocate tubes as described below.

1. Disconnect collector box pressure tube (pink label) attached to pressure switch.
2. Extend collector box pressure tube (green label) which was previously connected to condensate trap relief port connection by splicing to small diameter tube (factory-supplied in loose parts bag).
3. Connect collector box pressure tube (green label) to pressure switch connection labeled COLLECTOR BOX.
4. Extend collector box pressure tube (pink label) which was previously connected to pressure switch by splicing to remaining small diameter tube (factory-supplied in loose parts bag).
5. Route this extended tube (pink label) to condensate trap relief port connection.
6. Determine appropriate length, cut, and connect tube.
7. Clamp tube to relief port connection.

## CONDENSATE TRAP FREEZE PROTECTION

Refer to Condensate Drain Protection section for recommendations and procedures.

### Step 4—Horizontal Left (Supply-Air Discharge) Applications

A horizontal left furnace application is where furnace blower is located to the right of combustion and controls section of furnace, and conditioned air is discharged to the left.

### **⚠ CAUTION**

Local codes may require a drain pan under entire furnace and condensate trap when a condensing furnace is used in an attic application or over a finished ceiling.

**NOTE:** In Canada, installations shall be in accordance with current NSCP and/or local codes.

## CONDENSATE TRAP LOCATION

The condensate trap must be removed from the factory-installed blower shelf location and relocated in selected application location as shown in Fig. 2 or 9.

To relocate condensate trap from the blower shelf to desired location, perform the following:

1. Remove 3 tubes connected to condensate trap.
2. Remove trap from blower shelf by gently pushing tabs inward and rotating trap.
3. Install casing hole filler cap (factory-supplied in loose parts bag) into blower shelf hole where trap was removed.
4. Install casing hole filler cap into blower shelf hole where trap was removed.

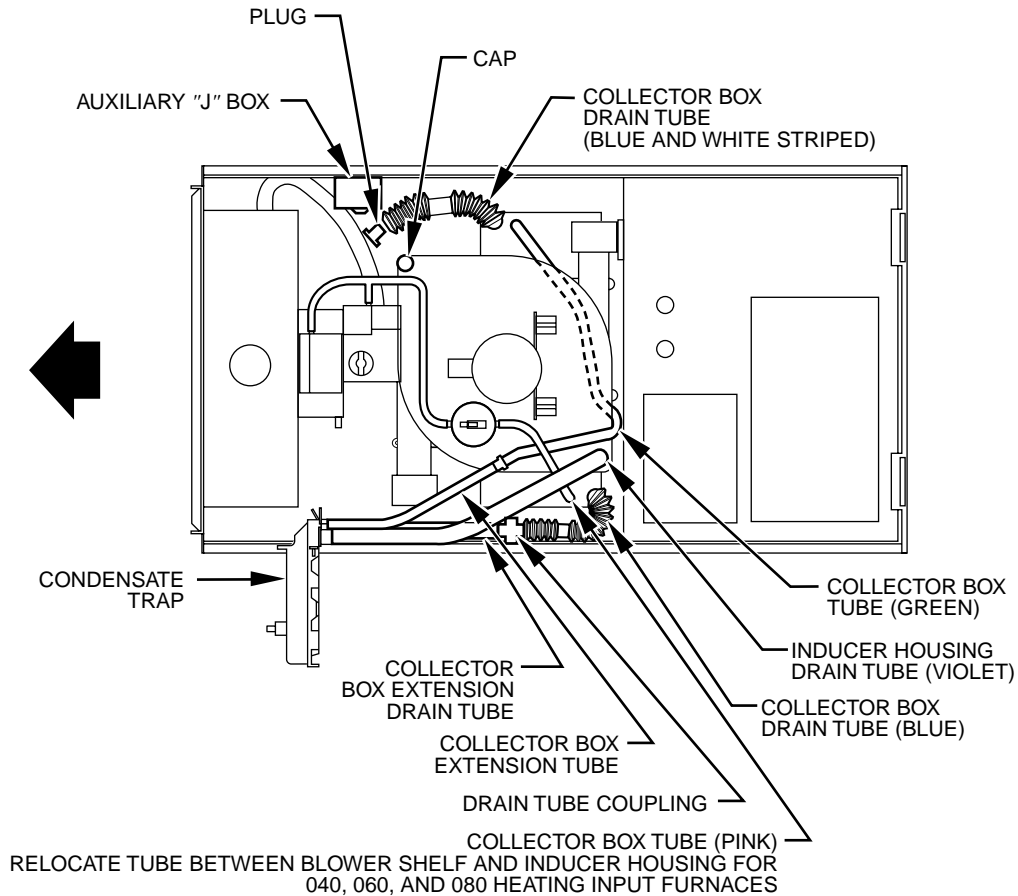

**Fig. 9—Horizontal Left Tube Configuration**

A00215

5. Fill unused condensate trap casing holes with plastic filler caps (factory-supplied in loose parts bag).

**CONDENSATE TRAP TUBING**

**NOTE:** See Fig. 9 or tube routing label on main furnace door to check for proper connections.

1. Collector Box Drain Tube
  - a. Install drain tube coupling (factory-supplied in loose parts bag) into collector box drain tube (blue label) which was previously connected to condensate trap.
  - b. Connect large diameter drain tube and clamp (factory-supplied in loose parts bag) to drain tube coupling, extending collector box drain tube.
  - c. Route extended tube (blue label) to condensate trap and cut to appropriate length.
  - d. Clamp tube to prevent any condensate leakage.
2. Inducer Housing Drain Tube
  - a. Remove and discard LOWER (molded) inducer housing drain tube which was previously connected to condensate trap.
  - b. Use inducer housing drain extension tube (violet label and factory-supplied in loose parts bag) to connect LOWER inducer housing drain connection to condensate trap.
  - c. Determine appropriate length, cut, and connect tube.
  - d. Clamp tube to prevent any condensate leakage.
3. Relief Port Tube
  - a. Extend collector box tube (green label) which was previously connected to condensate trap by splicing to small diameter tube (factory-supplied in loose parts bag).

- b. Route extended collector box pressure tube to relief port connection on condensate trap.
- c. Determine appropriate length, cut, and connect tube.
- d. Clamp tube to prevent any condensate leakage.

**CONDENSATE TRAP FIELD DRAIN ATTACHMENT**

Refer to Condensate Drain section for recommendations and procedures.

**PRESSURE SWITCH TUBING**

The LOWER collector box pressure tube (pink label) is factory connected to the pressure switch and should not require any modification.

**NOTE:** See Fig. 9 or tube routing label on main furnace door to check for proper connections.

**CONDENSATE TRAP FREEZE PROTECTION**

Refer to Condensate Drain Protection section for recommendations and procedures.

**CONSTRUCT A WORKING PLATFORM**

Construct working platform where all required furnace clearances are met. (See Fig. 3 and 10.)

<b>⚠ CAUTION</b>
The condensate trap <b>MUST</b> be installed below furnace. See Fig. 4 for dimensions. The drain connection to condensate trap must also be properly sloped to an open drain.

**NOTE:** Combustion-air and vent pipes are restricted to a minimum length of 5 ft. (See Table 6.)

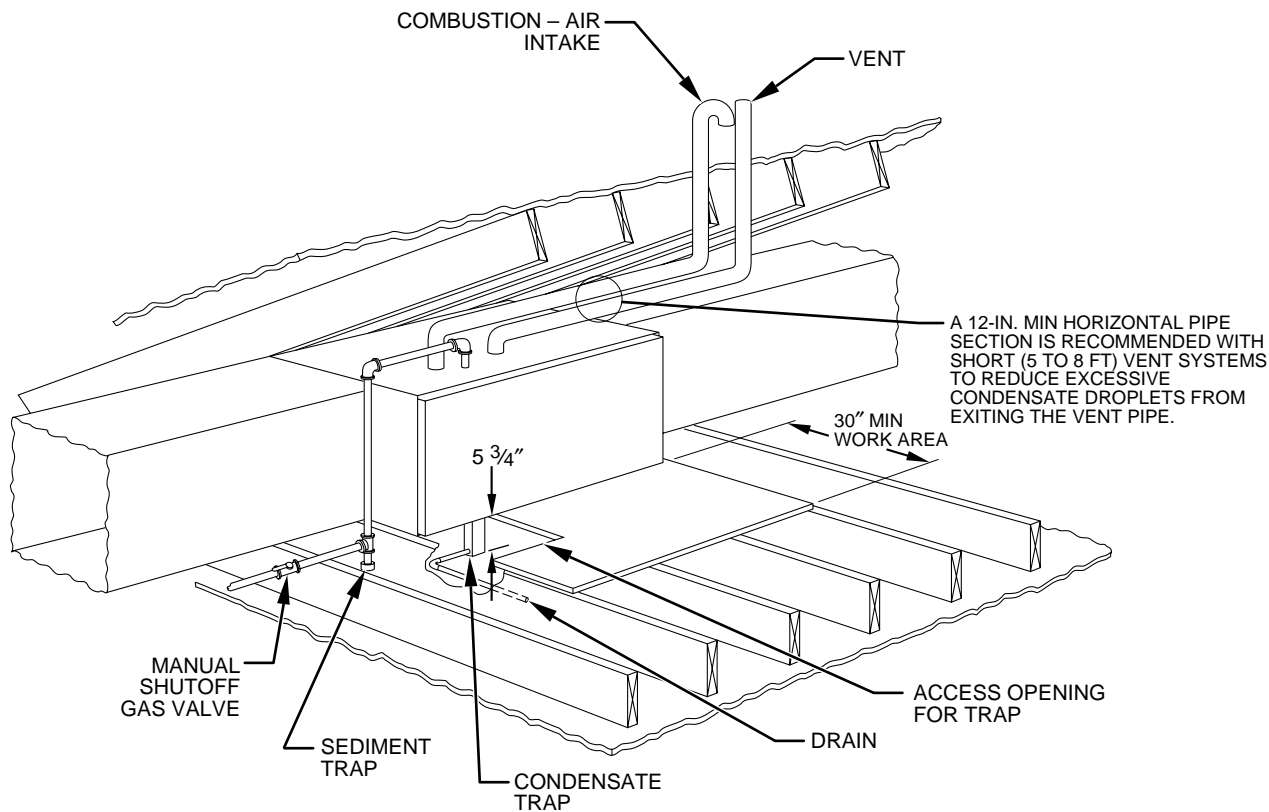

**NOTE:** LOCAL CODES MAY REQUIRE A DRAIN PAN UNDER THE FURNACE AND CONDENSATE TRAP WHEN A CONDENSING FURNACE IS INSTALLED ABOVE FINISHED CEILINGS.

A93031

**Fig. 10—Attic Location and Working Platform**

**NOTE:** A 12-in. minimum offset pipe section is recommended with short (5 to 8 ft) vent systems. This recommendation is to reduce excessive condensate droplets from exiting the vent pipe. (See Fig. 10 or 32.)

### Step 5—Horizontal Right (Supply-Air Discharge) Applications

A horizontal right furnace application is where furnace blower is located to the left of combustion and controls section of furnace, and conditioned air is discharged to the right.

#### **CAUTION**

Local codes may require a drain pan under entire furnace and condensate trap when a condensing furnace is used in attic application or over a finished ceiling.

**NOTE:** In Canada, installations shall be in accordance with current NSCP/NCC Installation Codes and/or local codes.

**NOTE:** The auxiliary junction box (J-box) MUST be relocated to opposite side of furnace casing. (See Fig. 11.) See Electrical Connection section for J-box relocation.

#### CONDENSATE TRAP LOCATION

The condensate trap must be removed from the factory-installed blower shelf location and relocated in selected application location as shown in Fig. 2 or 11.

To relocate condensate trap from the blower shelf to desired location, perform the following:

1. Remove 3 tubes connected to condensate trap.
2. Remove trap from blower shelf by gently pushing tabs inward and rotating trap.

3. Install casing hole filler cap (factory-supplied in loose parts bag) into blower shelf hole where trap was removed.
4. Install casing hole filler cap into blower shelf hole where trap was removed.
5. Fill unused condensate trap casing holes with plastic filler caps (factory-supplied in loose parts bag).

#### CONDENSATE TRAP TUBING

**NOTE:** See Fig. 11 or tube routing label on main furnace door to check for proper connections.

1. Collector Box Drain Tube
  - a. Remove factory-installed plug from LOWER collector box drain tube (blue and white striped label).
  - b. Install removed clamp and plug into UPPER collector box drain tube (blue label) which was previously connected to condensate trap.
  - c. Connect LOWER collector box drain tube (blue and white striped label) to condensate trap. Tube does not need to be cut.
  - d. Clamp tube to prevent any condensate leakage.
2. Inducer Housing Drain Tube
  - a. Remove factory-installed cap and clamp from LOWER inducer housing drain connection.
  - b. Remove and discard UPPER (molded) inducer housing drain tube which was previously connected to condensate trap.
  - c. Install cap and clamp on UPPER inducer housing drain connection where molded drain tube was removed.

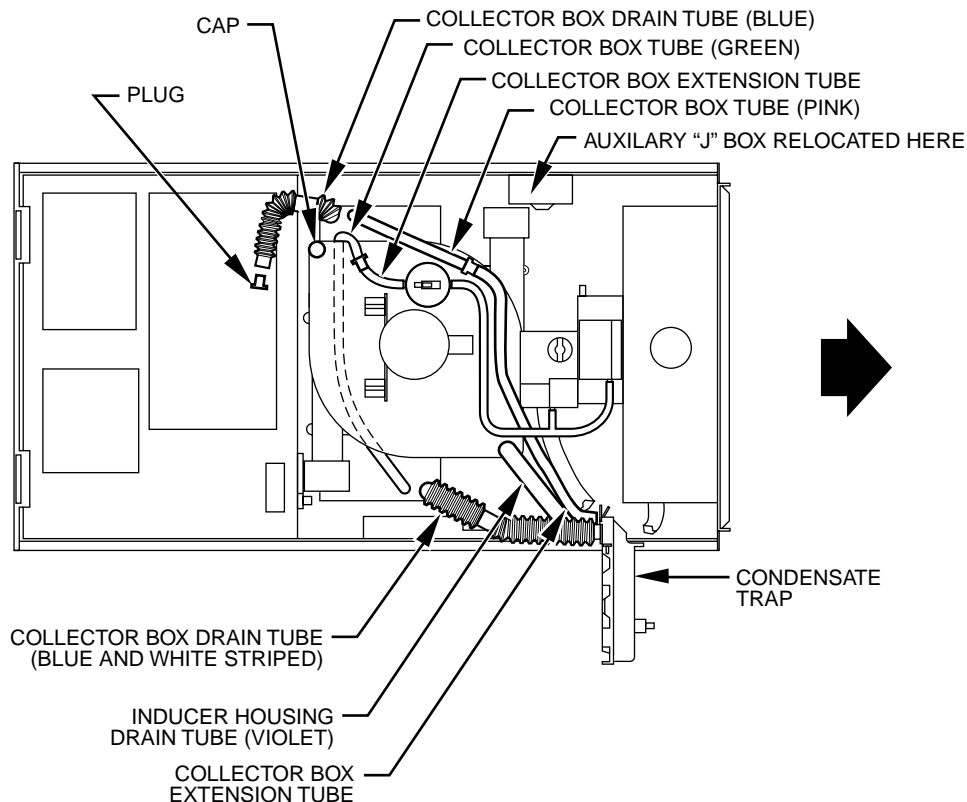

**Fig. 11—Horizontal Right Tube Configuration**

A00214

- d. Use inducer housing drain extension tube (violet label and factory-supplied in loose parts bag) to connect LOWER inducer housing drain connection to condensate trap.
- e. Determine appropriate length, cut, and connect tube to condensate trap.
- f. Clamp tube to prevent any condensate leakage.

**3. Relief Port Tube**

Refer to Pressure Switch Tubing section for connection procedure.

**CONDENSATE TRAP FIELD DRAIN ATTACHMENT**

Refer to Condensate Drain section for recommendations and procedures.

**PRESSURE SWITCH TUBING**

One collector box pressure tube (pink label) is factory connected to the pressure switch for use when furnace is installed in UPFLOW or HORIZONTAL LEFT applications. This tube MUST be disconnected and used for the condensate trap relief port tube. The other collector box pressure tube (green label) which was factory connected to the condensate trap relief port connection MUST be connected to the pressure switch in DOWNFLOW or HORIZONTAL RIGHT applications.

**NOTE:** See Fig. 11 or tube routing label on main furnace door to check for proper connections.

Relocate tubes as described below.

1. Disconnect collector box pressure tube (pink label) attached to pressure switch.
2. Extend collector box pressure tube (green label) which was previously connected to condensate trap relief port connection by splicing to small diameter tube (factory-supplied in loose parts bag).
3. Connect collector box pressure tube (green label) to pressure switch connection labeled COLLECTOR BOX.

4. Use remaining small diameter tube (factory-supplied in loose parts bag) to extend collector box pressure tube (pink label) which was previously connected to pressure switch.
5. Route this extended tube (pink label) to condensate trap relief port connection.
6. Determine appropriate length, cut, and connect tube.
7. Clamp tube to relief port connection.

**CONDENSATE TRAP FREEZE PROTECTION**

Refer to Condensate Drain Protection section for recommendations and procedures.

**CONSTRUCT A WORKING PLATFORM**

Construct working platform where all required furnace clearances are met. (See Fig. 3 and 10.)

<b>⚠ CAUTION</b>
The condensate trap <b>MUST</b> be installed below furnace. See Fig. 4 for dimensions. The drain connection to condensate trap must also be properly sloped to an open drain.

**NOTE:** Combustion-air and vent pipes are restricted to a minimum length of 5 ft. (See Table 6.)

**NOTE:** A 12-in. minimum offset pipe section is recommended with short (5 to 8 ft) vent systems. This recommendation is to reduce excessive condensate droplets from exiting the vent pipe. (See Fig. 10 or 29.)

**LOCATION**

**Step 1—General**

When a furnace is installed so that supply ducts carry air to areas outside the space containing the furnace, return air must also be handled by ducts sealed to furnace casing. The ducts terminate outside the space containing the furnace to ensure there will not be a negative pressure condition within equipment room or space.

Furnace may be located in a confined space without special provisions for dilution or ventilation air. This furnace must be installed so electrical components are protected from water.

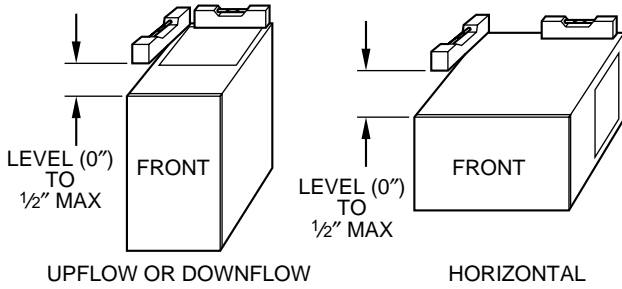

A93025

**NOTE:** For proper furnace operation, install furnace so that it is level or pitched forward within 1/2 in. to ensure proper condensate drainage from secondary heat exchangers.

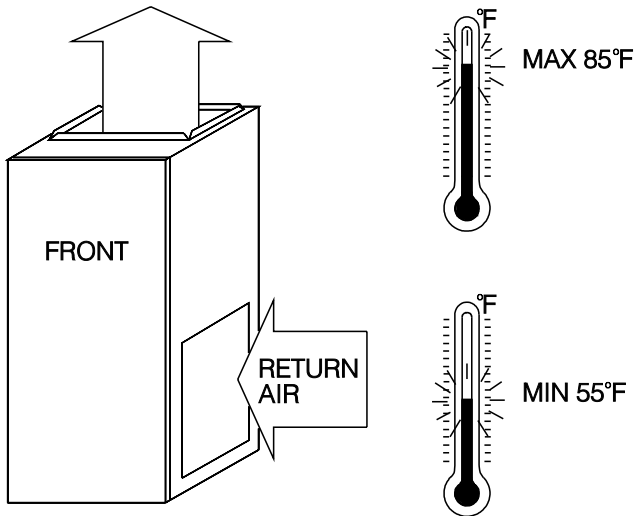

A93042

**NOTE:** These furnaces are designed for a minimum continuous return-air temperature of 60°F or intermittent operation down to 55°F such as when used with a night setback thermostat. Return-air temperature must not exceed a maximum of 85°F. Failure to follow these return-air temperature limits may affect reliability of heat exchangers, motors, and controls.

Locate furnace as close to center of air distribution system as possible.

Locate furnace so combustion-air pipe lengths are not exceeded. Refer to Table 6.

**CAUTION**

If these furnaces are used during construction when adhesives, sealers, and/or new carpets are being installed, make sure all combustion and circulating air requirements are followed. If operation of furnace is required during construction, use clean outside air for combustion and ventilation. Compounds of chlorine and fluorine, when burned with combustion air, form acids which will cause corrosion of heat exchangers. Some of these compounds are found in paneling, dry wall adhesives, paints, thinners, masonry cleaning materials, and many other solvents commonly used in the construction process.

Excessive exposure to contaminated combustion air will result in safety and performance related problems.

Provide ample space for servicing and cleaning. Always comply with minimum fire protection clearances shown on unit's clearance to combustibles label. (See Fig. 3.) Locate furnace where available electric power and gas supplies meet specifications on furnace rating plate.

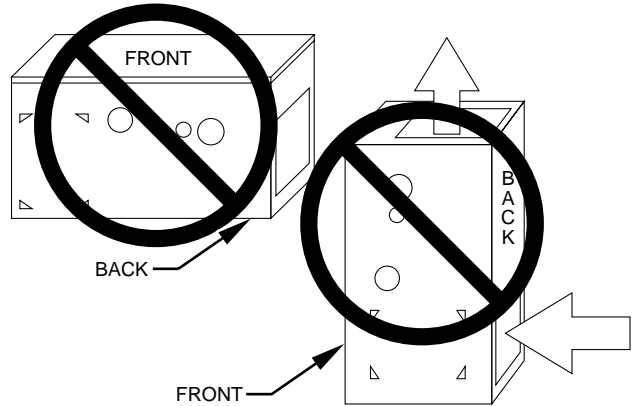

A93043

**WARNING**

Do not install furnace on its back. Safety control operation will be adversely affected. Never connect return-air ducts to back of furnace. Failure to follow this warning could result in fire, personal injury, or death.



A93058

**⚠ CAUTION**

If these furnaces are installed in an unconditioned space where ambient temperatures may be 32°F or lower, freeze protection measures must be taken.

**Step 2—Low-Fire Only Installation**

This 58MVP furnace can be installed to operate in the low-fire only heating mode when sized using the low-fire heating capacity. This is accomplished by placing setup switch SW-2 in the ON position to provide only low-fire-heat operation. See Fig. 25 and Table 10. With this setup, high-fire operation will not occur.

When the model no. on the furnace rating plate is followed by an asterisk (\*), the furnace has an alternate low-fire only efficiency rating as listed in the GAMA and CEC directories. This alternate rating will be listed as the furnace model number followed by an (-L) suffix.

**⚠ CAUTION**

The furnace can operate in the high-fire mode when certain fault conditions occur. The following precautions should be taken:

1. Size gas piping based on the high-fire input.
  2. Check the high-fire input and adjust it per the main literature instructions.
- NEVER assume the high-fire input rate is not important for low-fire-only installation.

**Step 3—Furnace Location Relative to Cooling Equipment**

The cooling coil must be installed parallel with or on downstream side of furnace to avoid condensation in heat exchanger. When installed parallel with a furnace, dampers or other means used to control flow of air must prevent chilled air from entering furnace. If dampers are manually operated, they must be equipped with a means to prevent operation of either unit unless damper is in full-heat or full-cool position.

**Step 4—Hazardous Locations**

**INSTALLATION**

**Step 1—Leveling Legs (If Desired)**

When furnace is used in upflow position with side inlet(s), leveling legs may be desired. (See Fig. 12.) Install field-supplied, corrosion-resistant 5/16-in. machine bolts and nuts.

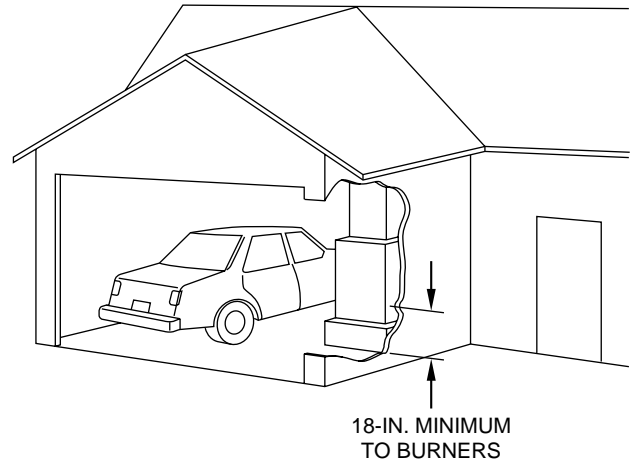

A93044

**⚠ WARNING**

When furnace is installed in a residential garage, it must be installed so that burners and ignition sources are located a minimum of 18 in. above floor. The furnace must be located or protected to avoid physical damage by vehicles. When furnace is installed in a public garage, airplane hangar, or other building having a hazardous atmosphere, unit must be installed in accordance with requirements of National Fire Protection Association, Inc.

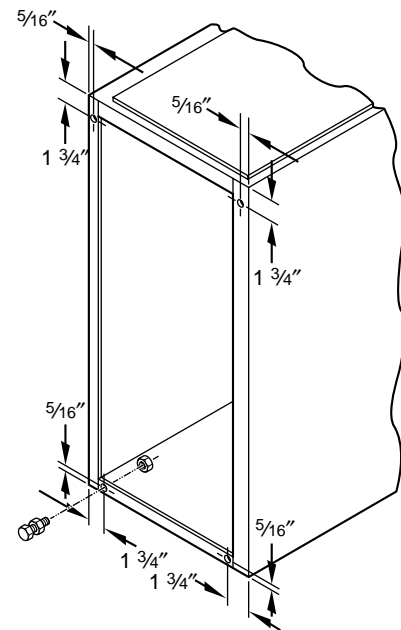

A89014

**Fig. 12—Leveling Legs**

**NOTE:** The maximum length of bolt should not exceed 1-1/2 in.

1. Position furnace on its back. Locate and drill a 5/16-in. diameter hole in each bottom corner of furnace. (See Fig. 12.) Holes in bottom closure panel may be used as guide locations.
2. For each hole, install nut on bolt and then install bolt and nut in hole. (Install flat washer if desired.)
3. Install another nut on other side of furnace base. (Install flat washer if desired.)
4. Adjust outside nut to provide desired height, and tighten inside nut to secure arrangement.

**NOTE:** Bottom closure must be used when leveling legs are used. See Bottom Closure Panel section.

### Step 2—Installation in Upflow or Downflow Applications

**NOTE:** This furnace is approved for use on combustibile flooring when manufacturer's accessory floor base, Part No. KGASB0201ALL, is used. Manufacturer's accessory floor base is not required when this furnace is installed on manufacturer's Coil Assembly Part No. CD5 or CK5, or Coil Box Part No. KCAKC is used.

1. Determine application being installed from Table 1.
2. Construct hole in floor per dimensions specified in Table 1 and Fig. 13.
3. Construct plenum to dimensions specified in Table 1 and Fig. 13.
4. If downflow subbase (KGASB) is used, install as shown in Fig. 14.

If coil assembly CD5 or CK5 or Coil Box KCAKC is used, install as shown in Fig. 15.

**NOTE:** Remove furnace perforated, discharge duct flanges when they interfere with mating flanges on coil on downflow subbase. To remove furnace perforated, discharge duct flange, use wide duct pliers or duct flange tool to bend flange back and forth until it breaks off. Be careful of sharp edges. (See Fig. 16.)

#### **⚠ WARNING**

Do not bend duct flanges inward as shown in Fig. 16. This will affect airflow across heat exchangers and may cause limit cycling or premature heat exchanger failure. Remove duct flange completely or bend it inward a minimum of 210° as shown in Fig. 16.

### Step 3—Installation in Horizontal Applications

These furnaces can be installed horizontally in either horizontal left or right discharge position. In a crawlspace, furnace can either be hung from floor joist or installed on suitable blocks or pad. Furnace can be suspended from each corner by hanger bolts and angle iron supports. (See Fig. 17.) Cut hanger bolts (4 each 3/8-in. all-thread rod) to desired length. Use 1 X 3/8-in. flat washers, 3/8-in. lockwashers, and 3/8-in. nuts on hanger rods as shown in Fig. 17. Dimples are provided for hole locations. (See Fig. 2.)

#### **⚠ CAUTION**

The entire length of furnace **MUST** be supported when furnace is used in a horizontal position to ensure proper draining. When suspended, bottom brace supports sides and center blower shelf. When unit is supported from the ground, blocks or pad should support sides and center blower shelf area.

## AIR DUCTS

### Step 1—General Requirements

The duct system should be designed and sized according to accepted national standards such as those published by: Air Conditioning Contractors Association (ACCA), Sheet Metal and Air Conditioning Contractors National Association (SMACNA) or American Society of Heating, Refrigerating and Air Conditioning Engineers (ASHRAE). Or consult factory *The Air Systems Design Guidelines* reference tables available from your local distributor. The duct system should be sized to handle the required system design CFM at the design static pressure.

When a furnace is installed so that the supply ducts carry air to areas outside the space containing the furnace, the return air must also be handled by a duct(s) sealed to the furnace casing and terminating outside the space containing the furnace.

Secure ductwork with proper fasteners for type of ductwork used. Seal supply- and return-duct connections to furnace with code approved tape or duct sealer.

Flexible connections should be used between ductwork and furnace to prevent transmission of vibration. Ductwork passing through unconditioned space should be insulated to enhance system performance. When air conditioning is used, a vapor barrier is recommended.

Maintain a 1-in. clearance from combustibile materials to supply air ductwork for a distance of 36 in. horizontally from the furnace. See NFPA 90B or local code for further requirements.

### Step 2—Ductwork Acoustical Treatment

Metal duct systems that do not have a 90 degree elbow and 10 ft of main duct to the first branch take-off may require internal acoustical lining. As an alternative, fibrous ductwork may be used if constructed and installed in accordance with the latest edition of SMACNA construction standard on fibrous glass ducts. Both acoustical lining and fibrous ductwork shall comply with NFPA 90B as tested by UL Standard 181 for Class 1 Rigid air ducts.

### Step 3—Supply Air Connections

#### UPFLOW FURNACES

Connect supply-air duct to 3/4-in. flange on furnace supply-air outlet. The supply-air duct attachment must **ONLY** be connected to furnace supply-/outlet-air duct flanges or air conditioning coil casing (when used). **DO NOT** cut main furnace casing to attach supply side air duct, humidifier, or other accessories. All accessories **MUST** be connected external to furnace main casing.

#### DOWNFLOW FURNACES

Connect supply-air duct to supply-air opening on furnace. The supply-air duct attachment must **ONLY** be connected to furnace supply/outlet or air conditioning coil casing (when used), when installed on non-combustibile material. When installed on combustibile material, supply-air duct attachment must **ONLY** be connected to an accessory subbase or factory approved air conditioning coil casing. **DO NOT** cut main furnace casing to attach supply side air duct, humidifier, or other accessories. All accessories **MUST** be connected external to furnace main casing.

#### HORIZONTAL FURNACES

Connect supply-air duct to supply air opening on furnace. The supply-air duct attachment must **ONLY** be connected to furnace supply/outlet or air conditioning coil casing (when used). **DO NOT** cut main furnace casing to attach supply side air duct, humidifier, or other accessories. All accessories **MUST** be connected external to furnace main casing.

### Step 4—Return Air Connections

#### UPFLOW FURNACES

The return-air duct must be connected to bottom, sides (left or right), or a combination of bottom and side(s) of main furnace casing as shown in Fig. 1. Bypass humidifier may be attached into unused side return air portion of the furnace casing. **DO NOT** connect any portion of return-air duct to back of furnace casing.

#### DOWNFLOW AND HORIZONTAL FURNACES

The return-air duct must be connected to return-air opening provided as shown in Fig. 1. **DO NOT** cut into casing sides or back to attach any portion of return-air duct. Bypass humidifier connections should be made at ductwork or coil casing sides exterior to furnace.

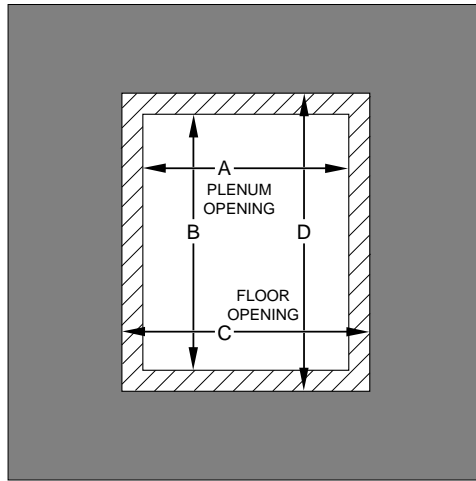

A96283

**Fig. 13—Floor and Plenum Opening Dimensions**

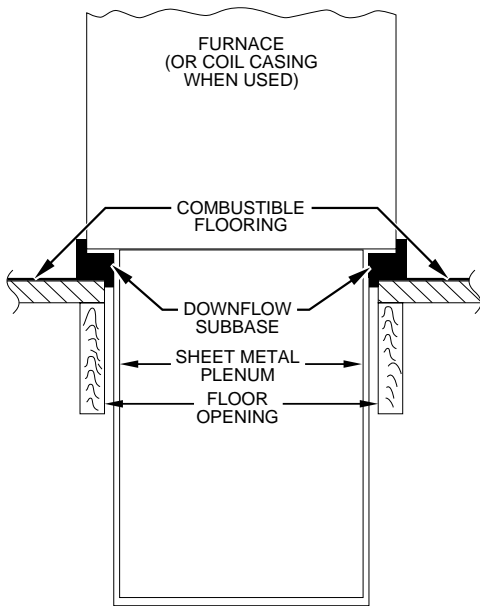

A96285

**Fig. 14—Furnace, Plenum, and Subbase Installed on a Combustible Floor**

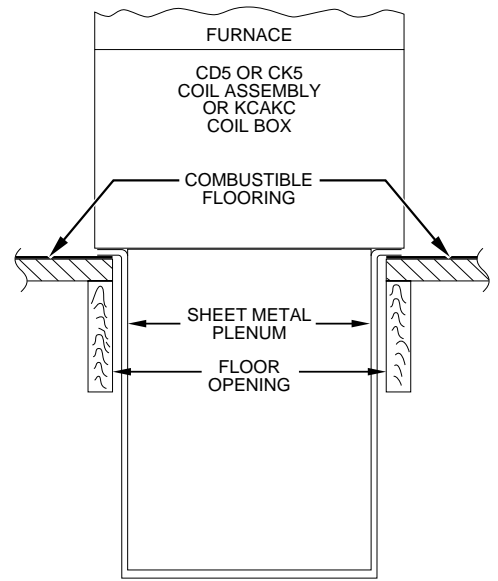

A96284

**Fig. 15—Furnace, Plenum, and Coil Assembly or Coil Box Installed on a Combustible Floor**

**Table 1—Opening Dimensions (In.)**

FURNACE CASING WIDTH	APPLICATION	PLENUM OPENING		FLOOR OPENING	
		A	B	C	D
17-1/2	Upflow Applications	16	24-1/8	16-5/8	24-3/4
	Downflow Applications on Non-Combustible Flooring	15-7/8	19	16-1/2	19-5/8
	Downflow Applications on Combustible Flooring Using KGASB Subbase Furnace with or without CD5 or CK5 Coil Assembly or KCAKC Coil Box	15-1/8	19	16-3/4	20-3/8
	Downflow Applications on Combustible Flooring NOT Using KGASB Subbase Furnace with CD5 or CK5 Coil Assembly or KCAKC Coil Box	15-1/2	19	16-1/2	20
21	Upflow Applications	19-1/2	24-1/8	20-1/8	24-3/4
	Downflow Applications on Non-Combustible Flooring	19-3/8	19	20	19-5/8
	Downflow Applications on Combustible Flooring Using KGASB Subbase Furnace with or without CD5 or CK5 Coil Assembly or KCAKC Coil Box	18-5/8	19	20-1/4	20-3/8
	Downflow Applications on Combustible Flooring NOT Using KGASB Subbase Furnace with CD5 or CK5 Coil Assembly or KCAKC Coil Box	19	19	20	20
24-1/2	Upflow Applications	23	24-1/8	23-5/8	24-3/4
	Downflow Applications on Non-Combustible Flooring	22-7/8	19	23-1/2	19-5/8
	Downflow Applications on Combustible Flooring Using KGASB Subbase Furnace with or without CD5 or CK5 Coil Assembly or KCAKC Coil Box	22-1/8	19	23-3/4	20-3/8
	Downflow Applications on Combustible Flooring NOT Using KGASB Subbase Furnace with CD5 or CK5 Coil Assembly or KCAKC Coil Box	22-1/2	19	23-1/2	20

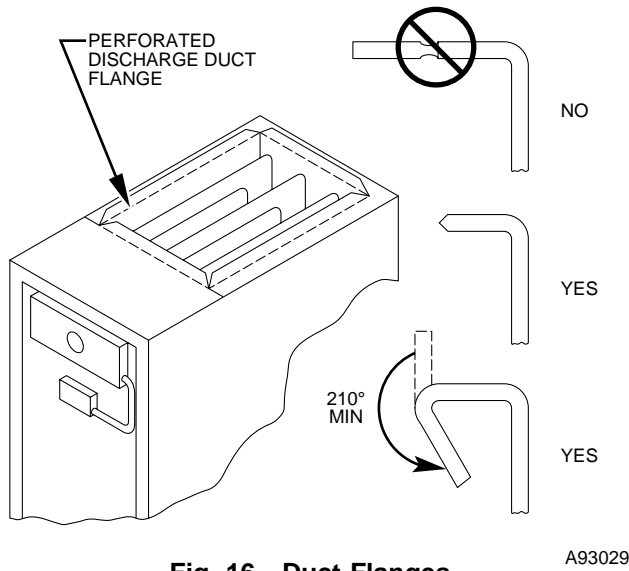

**Fig. 16—Duct Flanges**

A93029

**Step 5—Filter Arrangement**

**⚠ WARNING**

Never operate unit without a filter or with filter access door removed. Failure to follow this warning can cause fire, personal injury, or death.

The air filter arrangement will vary due to application and filter type. The filter may be installed in an external Filter/Media cabinet (if provided) or the furnace blower compartment. Factory supplied washable filters are shipped in the blower compartment.

If a factory-supplied external Filter/Media cabinet is provided, instructions for its application, assembly, and installation are packaged with the cabinet. The Filter/Media cabinet can be used with the factory-supplied washable filter or a factory-specified high-efficiency disposable filter (see cabinet instructions).

If installing the filter in the furnace blower compartment, determine location for filter and relocate filter retaining wire if necessary. See Table 2 to determine correct filter size for desired filter location. Table 2 indicates filter size, location, and quantity shipped with this furnace. See Fig. 2 for location and size of bottom and side return-air openings.

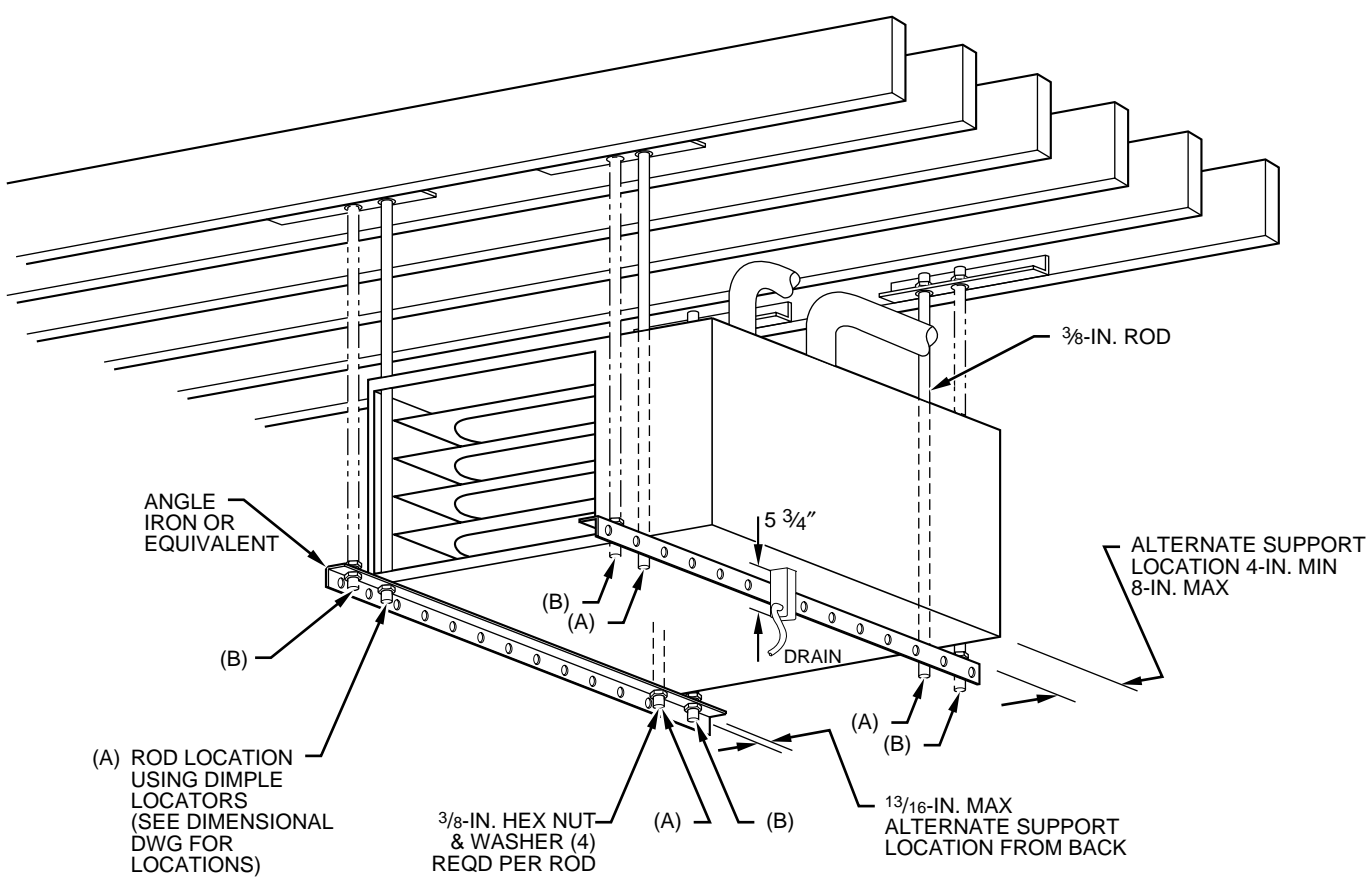

(A) ROD LOCATION USING DIMPLE LOCATORS (SEE DIMENSIONAL DWG FOR LOCATIONS)

(A) PREFERRED ROD LOCATION  
(B) ALTERNATE ROD LOCATION

**NOTES:** 1. A 1 in. clearance minimum between top of furnace and combustible material.  
2. The entire length of furnace must be supported when furnace is used in horizontal position to ensure proper drainage.

**Fig. 17—Crawlspace Horizontal Application**

A93304

**Table 2—Filter Information**

FURNACE CASING WIDTH (IN.)	FILTER SIZE (IN.)*		FILTER TYPE FRAMED
	Side Return	Bottom Return	
17-1/2	(1) 16 X 25 X 1†	(1) 16 X 25 X 1†	Cleanable
21	(1) 16 X 25 X 1	(1) 20 X 25 X 1†	Cleanable
24-1/2	(1 or 2) 16 X 25 X 1	(1) 24 X 25 X 1†	Cleanable

\* Filters may be field modified by cutting filter material and support rods (3) in filters. Alternate sizes can be ordered from your distributor or dealer.  
 † Factory-provided with furnace.

**CAUTION**  
 Use care when cutting support rods in filters to protect against flying pieces and sharp rod ends. Wear safety glasses, gloves, and appropriate protective clothing. Failure to follow this caution could result in personal injury.

**CAUTION**  
 For airflow requirements above 1800 CFM, see Air Delivery table in Product Data literature for specific use of single side inlets. The use of both side inlets, a combination of 1 side and the bottom, or the bottom only will ensure adequate return air openings for airflow requirements above 1800 CFM.

**NOTE:** Side return-air openings can ONLY be used in UPFLOW configurations. Install filter(s) as shown in Fig. 18.

For bottom return-air applications, filter may need to be cut to fit some furnace widths. Install filter as shown in Fig. 19.

**NOTE:** Remove and discard bottom closure panel when bottom inlet is used.

**Step 6—Bottom Closure Panel**

These furnaces are shipped with bottom closure panel installed in bottom return-air opening. This panel MUST be in place when side return air is used.

To remove bottom closure panel, perform following:

1. Tilt or raise furnace and remove 2 screws holding front filler panel. (See Fig. 20.)
2. Rotate front filler panel downward to release holding tabs.
3. Remove bottom closure panel.
4. Reinstall front filler panel and screws.

**Step 7—Gas Piping**

Gas piping must be installed in accordance with national and local codes. Refer to current edition of NFGC. Canadian installations must be made in accordance with NSCNGPIC and all authorities

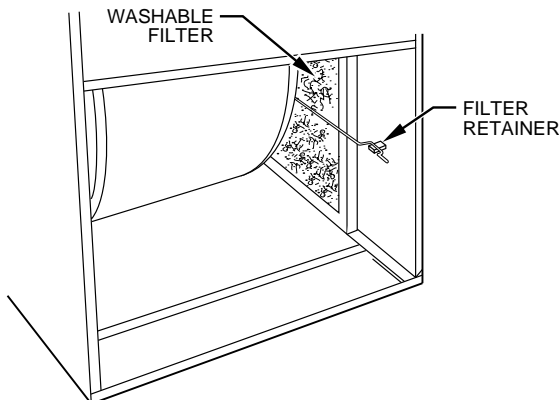
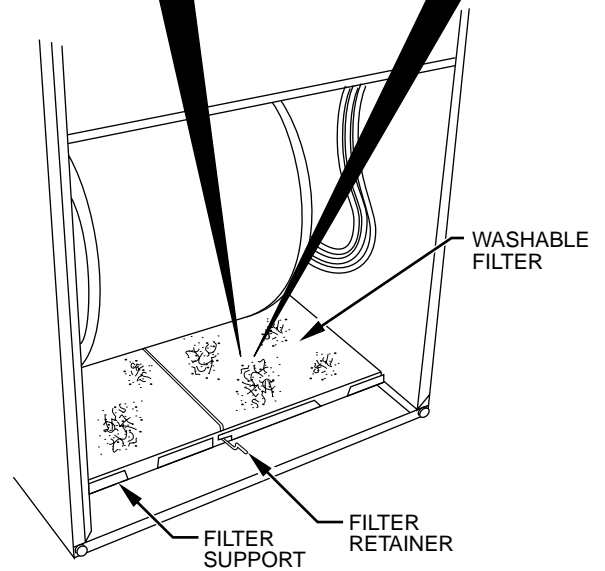
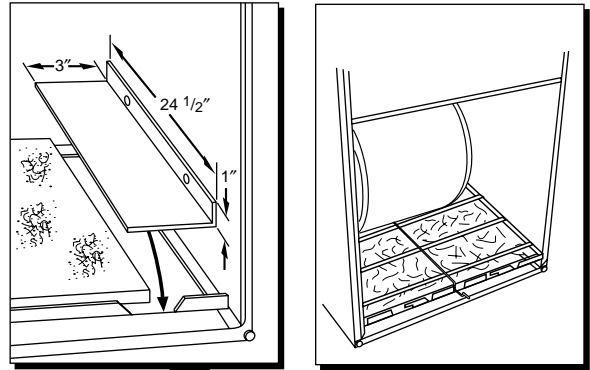

**Fig. 18—Filter Installed for Side Inlet**

A93045

**17½-IN. WIDE CASINGS ONLY:**  
 INSTALL FIELD-SUPPLIED FILTER FILLER STRIP UNDER FILTER.

**21-IN. WIDE CASINGS ONLY:**  
 SUPPORT RODS (3)  
 EXTEND ¼" ON EACH SIDE OF FILTER AND REST ON CASING FLANGE



**Fig. 19—Bottom Filter Arrangement**

A00290

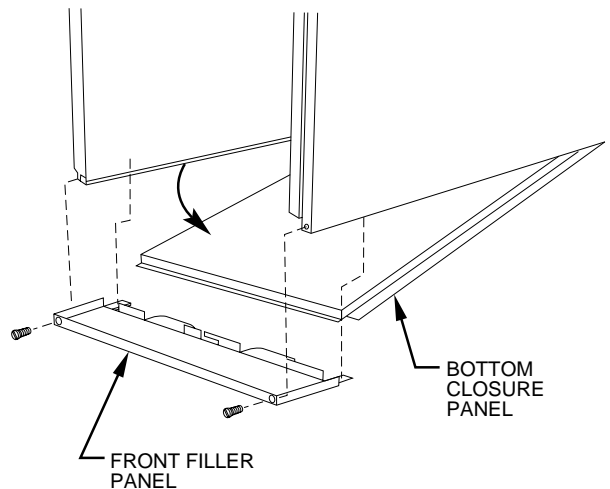

**Fig. 20—Removing Bottom Closure Panel**

A93047

having jurisdiction. Gas supply line should be a separate line running directly from meter to furnace, if possible. Refer to Table 3 for recommended gas pipe sizing. Risers must be used to connect to furnace and to meter. Support all gas piping with appropriate

straps, hangers, etc. Use a minimum of 1 hanger every 6 ft. Joint compound (pipe dope) should be applied sparingly and only to male threads of joints. Pipe dope must be resistant to propane gas.

**Table 3—Maximum Capacity of Pipe\***

NOMINAL IRON PIPE SIZE (IN.)	INTERNAL DIAMETER (IN.)	LENGTH OF PIPE (FT)				
		10	20	30	40	50
1/2	0.622	175	120	97	82	73
3/4	0.824	360	250	200	170	151
1	1.049	680	465	375	320	285
1-1/4	1.380	1400	950	770	660	580
1-1/2	1.610	2100	1460	1180	990	900

\* Cubic ft of gas per hr for gas pressures of 0.5 psig (14-in. wc) or less, and a pressure drop of 0.5-in. wc (based on a 0.60 specific gravity gas). Ref: Table 10-2 NFPA 54-1999.

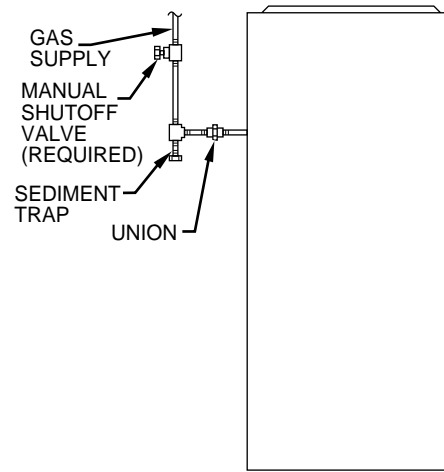

A93324

**Fig. 21—Typical Gas Pipe Arrangement**

**CAUTION**  
Connect gas pipe to furnace using a backup wrench to avoid damaging gas controls.

**WARNING**  
Gas valve shutoff switch **MUST** be facing forward or tilted upward. Failure to follow this warning could result in property damage or death.

**WARNING**  
Never purge a gas line into a combustion chamber. Never use matches, candles, flame, or other sources of ignition for purpose of checking leakage. Use a soap-and-water solution to check for leakage. A failure to follow this warning could result in fire, explosion, personal injury, or death.

**WARNING**  
Use proper length of pipe to avoid stress on gas control manifold. Failure to follow this warning could result in a gas leak resulting in fire, explosion, personal injury, or death.

Install a sediment trap in riser leading to furnace. Trap can be installed by connecting a tee to riser leading to furnace so straight-through section of tee is vertical. Then connect a capped nipple into lower end of tee. Capped nipple should extend below level of gas controls. Place a ground joint union between gas control manifold and manual gas shutoff valve. (See Fig. 21.)

**CAUTION**  
If a flexible connector is required or allowed by authority having jurisdiction, black iron pipe shall be installed at gas valve and extend a minimum of 2 in. outside furnace casing.

An accessible manual shutoff valve **MUST** be installed upstream of furnace gas controls and within 6 ft of furnace. A 1/8-in. NPT plugged tapping, accessible for test gage connection, **MUST** be installed immediately upstream of gas supply connection to furnace and downstream of manual shutoff valve.

**NOTE:** The gas valve inlet press tap connection is suitable to use as test gage connection providing test pressure **DOES NOT** exceed maximum 0.5 psig (14-in. wc) stated on gas valve. (See Fig. 50.) Piping should be pressure tested in accordance with local and national plumbing and gas codes before furnace has been attached. In Canada, refer to current edition of NSCPGIC. If pressure exceeds 0.5 psig (14-in. wc), gas supply pipe must be disconnected

from furnace and capped before pressure test. If test pressure is equal to or less than 0.5 psig (14-in. wc), turn off electric shutoff switch located on gas valve before test. It is recommended that ground joint union be loosened before pressure testing. After all connections have been made, purge lines and check for leakage.

**ELECTRICAL CONNECTIONS**

See Fig. 22 for field wiring diagram showing typical field 115-v and 24-v wiring. Check all factory and field electrical connections for tightness.

**WARNING**  
Blower access panel door switch opens 115-v power to control center. No component operation can occur. Do not bypass or close switch with panel removed. Failure to follow this warning could result in personal injury or death.

**CAUTION**  
Furnace control must be grounded for proper operation or control will lock out. Control is grounded through green wire routed to gas valve and burner box screw.

**Step 1—115-v Wiring**

Before proceeding with electrical connections, make certain that voltage, frequency, and phase correspond to that specified on unit rating plate. Also, check to be sure that service provided by utility is sufficient to handle load imposed by this equipment. Refer to rating plate or Table 4 for equipment electrical specifications.

Make all electrical connections in accordance with NEC ANSI/NFPA 70-1999 and any local codes or ordinances that might apply. For Canadian installations, all electrical connections must be made in accordance with Canadian Electrical Code CSA C22.1 or subauthorities having jurisdiction.

Use a separate, fused branch electrical circuit containing a properly sized fuse or circuit breaker for this furnace. See Table 4 for wire size and fuse specifications. A disconnecting means must be located within sight from and readily accessible to furnace.

**NOTE:** Proper polarity must be maintained for 115-v wiring. If polarity is incorrect, control center fault code indicator light will flash rapidly and furnace will **NOT** operate.

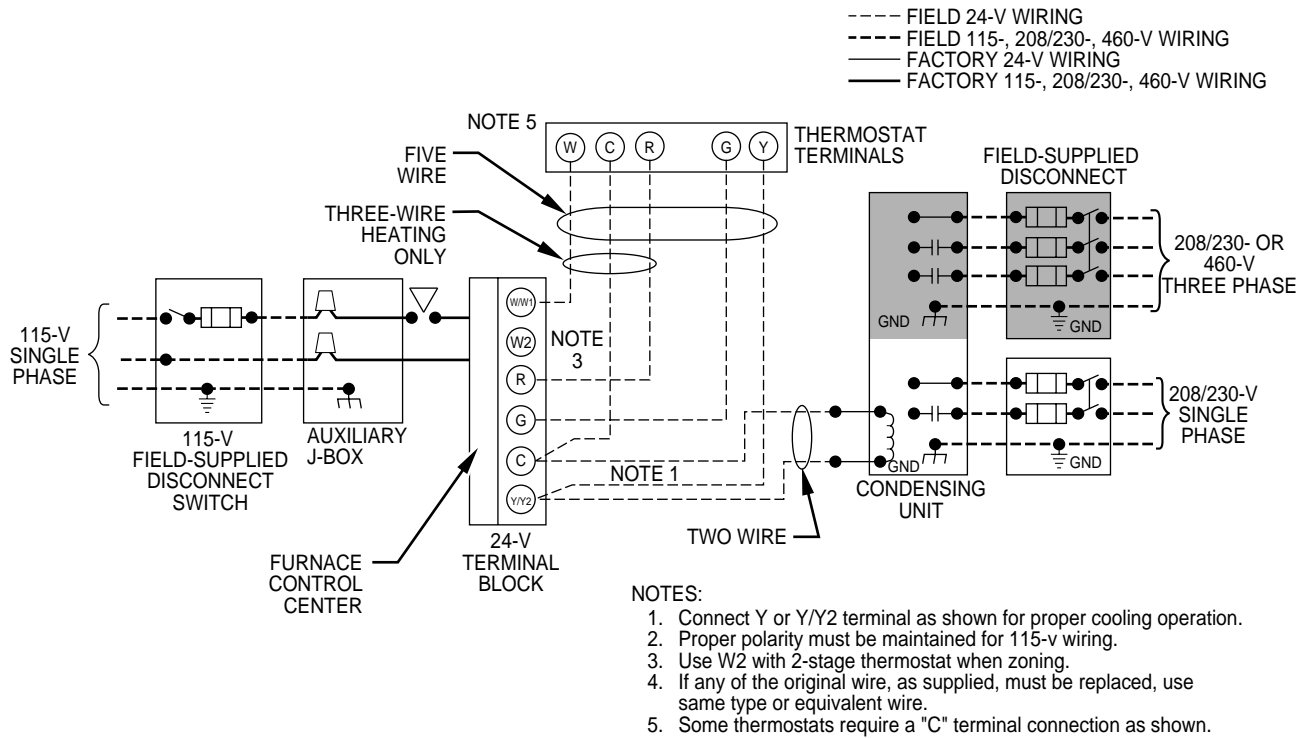
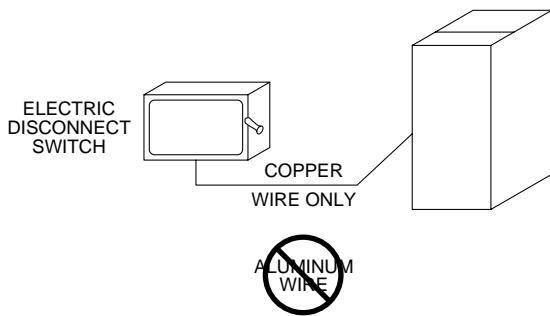

Fig. 22—Heating and Cooling Application Wiring Diagram

A98325



A93033

**CAUTION**

Do not connect aluminum wire between disconnect switch and furnace. Use only copper wire.

**WARNING**

The cabinet MUST have an uninterrupted or unbroken ground according to NEC ANSI/NFPA 70-1999 and Canadian Electrical Code CSA C22.1 or local codes to minimize personal injury if an electrical fault should occur. This may consist of electrical wire or conduit approved for electrical ground when installed in accordance with existing electrical codes. Do not use gas piping as an electrical ground. Failure to follow this warning could result in electric shock, fire, or death.

**J-Box Relocation**

1. Remove 2 screws holding auxiliary J-box. (See Fig. 23.)
2. Rotate J-box 180° and attach box to right side, using holes provided.

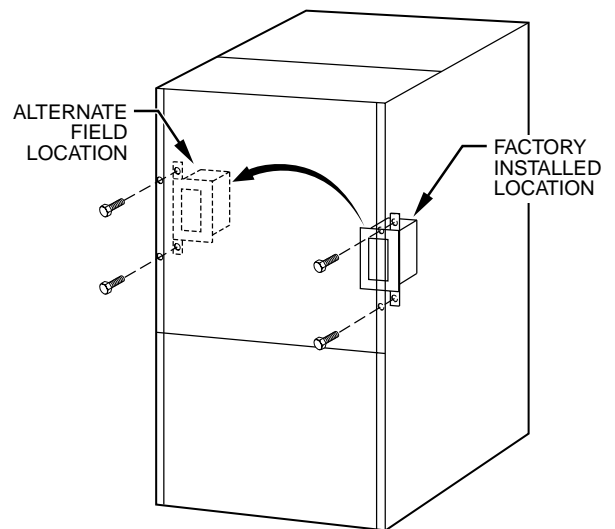

Fig. 23—Relocating J-Box

A00212

**CAUTION**

If manual disconnect switch is to be mounted on furnace, select a location where a drill or fastener will not contact electrical or gas components.

**Step 2—24-v Wiring**

Make field 24-v thermostat connections at 24-v terminal block on control center. Y wire from thermostat MUST be connected to Y terminal on control center, as shown in Fig. 22, for proper cooling operation. The 24-v terminal board is marked for easy connection of field wiring. (See Fig. 24.) The 24-v circuit contains a 3-amp, automotive-type fuse located on control center. (See Fig. 25.) Any electrical shorts of 24-v wiring during installation, service, or maintenance may cause fuse to blow. If fuse replacement is required, use only a fuse of identical size (3 amp).



**Table 4—Electrical Data**

UNIT SIZE	VOLTS—HERTZ—PHASE	OPERATING VOLTAGE RANGE		MAXIMUM UNIT AMPS	UNIT AMPACITY†	MINIMUM WIRE SIZE	MAXIMUM WIRE LENGTH (FT)‡	MAXIMUM FUSE OR CKT BKR AMPS**
		Maximum*	Minimum*					
040-14	115—60—1	127	104	8.9	12.0	14	31	15
060-14	115—60—1	127	104	8.9	12.0	14	31	15
080-14	115—60—1	127	104	8.9	12.0	14	31	15
080-20	115—60—1	127	104	13.8	17.9	12	32	20
100-20	115—60—1	127	104	13.8	18.1	12	32	20
120-20	115—60—1	127	104	11.6	15.3	12	37	20

\* Permissible limits of voltage range at which unit will operate satisfactorily.

† Unit ampacity = 125 percent of largest operating component's full load amps plus 100 percent of all other potential operating components' (EAC, humidifier, etc.) full load amps.

‡ Length shown is as measured 1 way along wire path between unit and service panel for maximum 2 percent voltage drop.

\*\* Time-delay type is recommended.

**NOTE:** Use AWG No. 18 color-coded copper thermostat wire for lengths up to 100 ft. For wire lengths over 100 ft, use AWG No. 16 wire.

**NOTE:** For 2-speed applications, refer to Sequence of Operation section.

**Step 3—Accessories**

1. Electronic Air Cleaner (EAC)

The control center EAC terminals are energized with 115v (1.5-amp maximum) during blower operation.

a. Two extension leads are connected to the control center EAC terminals to assist field installation of an EAC. (See Fig. 25.) To use these leads, proceed with the following:

- (1.) Strip EAC power lead insulation approximately 1/4 in.
- (2.) Insert stripped end into factory-supplied black lead's butt connector and crimp to secure.

(3.) Strip EAC neutral lead insulation approximately 1/4 in.

(4.) Insert stripped end into factory-supplied white leads' butt connector and crimp to secure.

**NOTE:** If desired, cut butt connectors off factory leads and strip insulation approximately 1/4 in and use field-supplied wire nuts to connect.

b. An alternate method to attach EAC lead to control center is the following procedure:

- (1.) Remove 2 screws securing the control box to furnace blower shelf.
- (2.) Remove and discard 2 factory-supplied leads from control center EAC terminals.
- (3.) Strip EAC power leads insulation approximately 1/8 in.

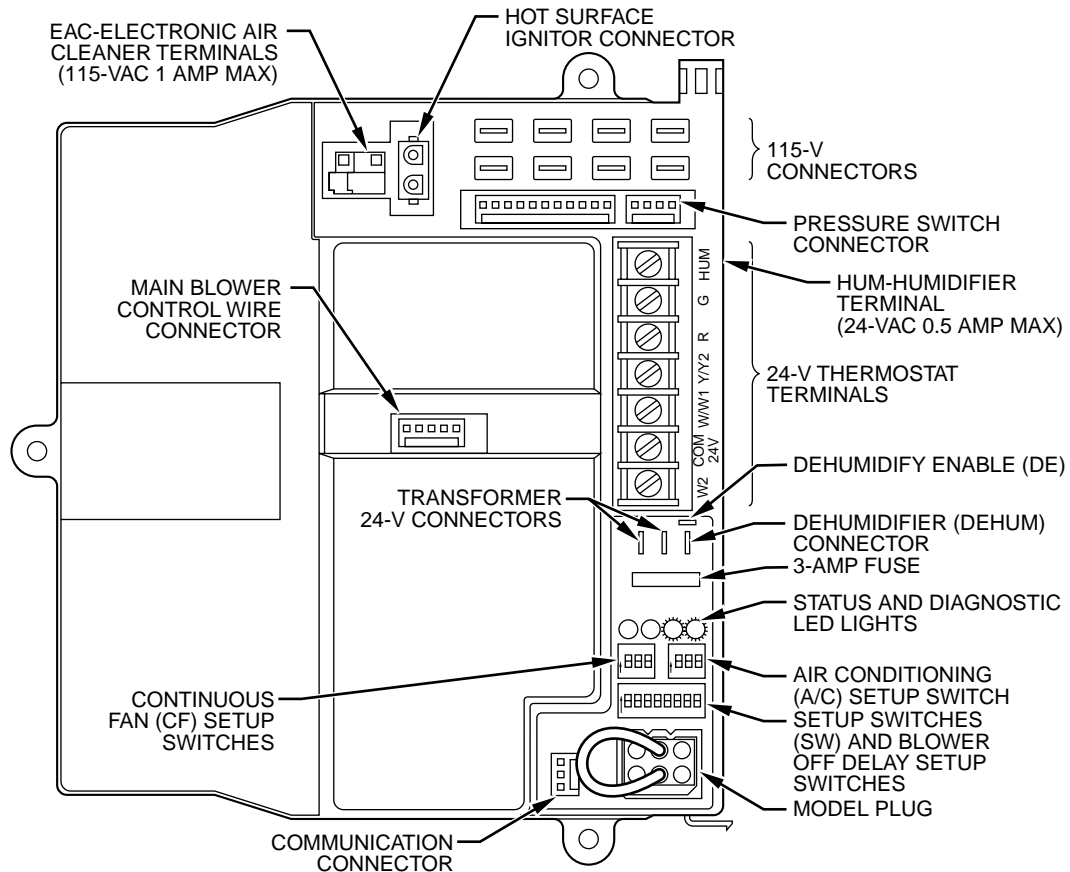

**Fig. 25—Control Center**

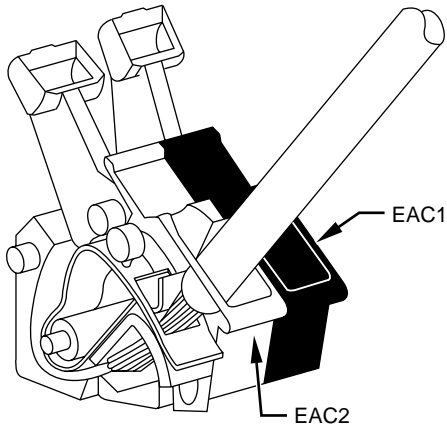

A93053

**Fig. 26—EAC Terminals on Control Center**

**NOTE:** The control center EAC terminals are sized for 12 gage maximum, solid or stranded wire.

- (4.) Route EAC leads through right-hand wire grommet.
  - (5.) Insert EAC stripped leads into control center EAC terminals by depressing terminal's arm with a screwdriver or finger. (See Fig. 26.)
  - (6.) Reinstall control box to furnace blower shelf using 2 screws removed earlier.
2. Humidifier (HUM)

Screw terminals (HUM and Com) are provided for 24-v humidifier connection. (See Fig. 24.) HUM terminal is energized with 24v (0.5-amp maximum) after inducer motor prepurge period.

**NOTE:** A field-supplied, 115-v controlled relay connected to EAC terminals may be added if humidifier operation is desired during blower operation.

3. Dehumidification (DEHUM)

A dehumidification input is provided via a 1/4-in. male quick-connect labeled DEHUM located next to the transformer secondary connections. When there is a dehumidify demand, the DEHUM input is activated, which means 24 vac signal is removed from the DEHUM input terminal. In other words, the DEHUM input logic is reversed. The DEHUM input is turned ON when no dehumidify demand exists and is turned OFF when demand exists. This logic reversal has come about from historical use of a standard humidistat to do dehumidification since the contacts open on high humidity, thus removing the 24-v signal to initiate dehumidification.

The DEHUM output on the thermidstat control or the humidistat output is connected directly to the DEHUM terminal on the furnace control. In addition, the DE jumper located next to the DEHUM terminal must be removed to enable the DEHUM input. (See Fig. 27 and 28.) When a dehumidify demand exists, the furnace control reduces the blower airflow by 21 percent to 315 CFM per ton during continuous fan or cooling operation.

**DIRECT VENTING**

The 58MVP Furnaces require a dedicated (one 58MVP furnace only) direct-vent system. In a direct-vent system, all air for combustion is taken directly from outside atmosphere, and all flue products are discharged to outside atmosphere.

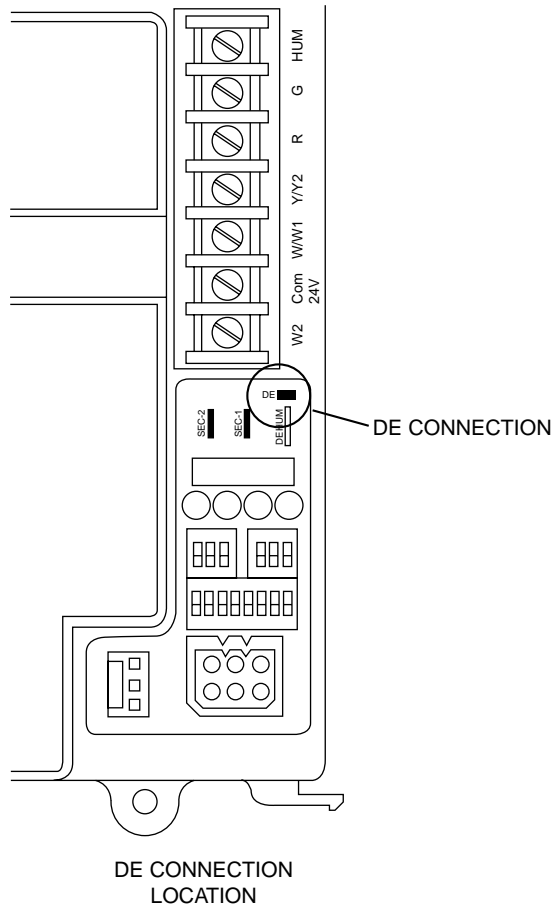

**Fig. 27—58MVP Variable Speed Furnace Control**

A99098

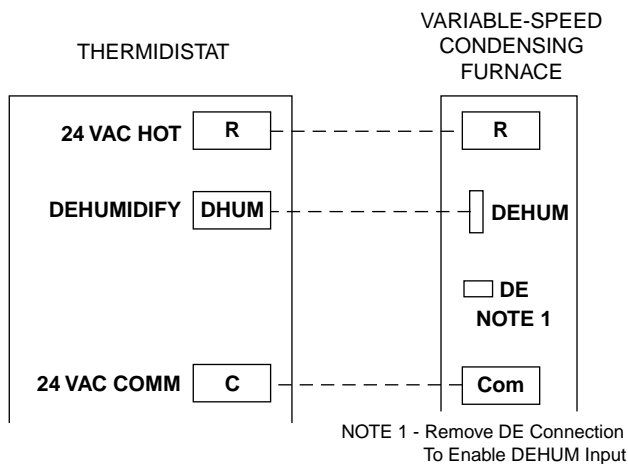

**Fig. 28—Thermidistat Connection**

A98295

**Step 1—Removal of Existing Furnaces from Common Vent Systems**

If furnace being replaced was connected to a common vent system with other appliances, the following steps shall be followed with each appliance connected to the venting system placed in operation, while any other appliances connected to the venting system are not in operation:

1. Seal any unused openings in the venting system.
2. Inspect the venting system for proper size and horizontal pitch as required in the National Fuel Gas Code, NFPA 54-1999/ANSI Z223.1-1999 or the CAN/CGA B149 Installation Codes and these instructions. Determine that there is no blockage or restriction, leakage, corrosion, and other deficiencies which could cause an unsafe condition.
3. If practical, close all building doors and windows and all doors between the space in which the appliance(s) connected to the venting system are located and other spaces of the building. Turn on clothes dryers and any appliance not connected to the venting system. Turn on any exhaust fans, such as range hoods and bathroom exhausts, so they shall operate at maximum speed. Do not operate a summer exhaust fan. Close fireplace dampers.
4. Follow the lighting instructions. Place the appliance being inspected in operation. Adjust thermostat so appliance shall operate continuously.
5. Test for draft hood equipped appliance spillage at the draft hood relief opening after 5 minutes of main burner operation. Use the flame of a match or candle.
6. After it has been determined that each appliance connected to the venting system properly vents when tested as outlined above, return doors, windows, exhaust fans, fireplace dampers, and any other gas-burning appliance to their previous conditions of use.
7. If improper venting is observed during any of above tests, the venting system must be corrected.

Vent system or vent connectors may need to be resized. For any other appliances when resizing vent systems or vent connectors, system or connector must be sized to approach minimum size as determined using appropriate table found in the NFGC or NSC-NGPIC.

**Step 2—Combustion-Air and Vent Piping**

**GENERAL**

Combustion-air and vent pipe fittings must conform to American National Standards Institute (ANSI) standards and American Society for Testing and Materials (ASTM) standards D1785 (schedule-40 PVC), D2665 (PVC-DWV), D2241 (SDR-21 and SDR-26 PVC), D2661 (ABS-DWV), F628 (schedule-40 ABS), F891 (PVC-DWV cellular core) or F441 (schedule-40 CPVC pipe) and F438 (schedule -40 CPVC fittings). Pipe cement and primer must conform to ASTM standards D2564 or F493 (PVC or CPVC) D2235 (ABS). See Table 6 for maximum pipe lengths and Fig. 34, 35, 36, 37, and 38 for exterior piping arrangements.

In Canada, construct all combustion-air and vent pipes for this unit of CSA or ULC certified schedule-40 PVC, PVC-DWV or ABS-DWV pipe and pipe cement. SDR pipe is NOT approved in Canada.

**NOTE:** Furnace combustion-air and vent pipe connections are sized for 2-in. pipe. Any pipe size change should be made outside furnace casing in vertical pipe. (See Fig. 29.) This allows proper drainage of vent condensate.

Combustion-air and vent pipes must terminate together in same atmosphere pressure zone, either through roof or sidewall (roof termination preferred), using accessory termination kit. See Table 5 for required clearances.

**Table 5—Combustion-Air and Vent Pipe Termination Clearances**

LOCATION	CLEARANCE (FT)	
	U.S.A.	Canada
<b>Above grade level or above anticipated snow depth</b>	1	1†
<b>Dryer vent</b>	3	3
<b>From plumbing vent stack</b>	3	3
<b>From any mechanical fresh air intake</b>	1	6
<b>For furnaces with an input capacity less than 100,000 Btuh—from any non-mechanical air supply (windows or doors which can be opened) or combustion-air opening</b>	1	1
<b>From service regulator vent, electric and gas meters, and relief equipment</b>	4*	6‡
<b>Above grade when adjacent to public walkway</b>	Note 3	Note 3

\* Horizontal distance.  
 † 18 in. above roof surface in Canada.  
 ‡ 36 in. to electric meter in Canada only.

**NOTES:**

1. If installing 2 adjacent 58MVP Furnaces, refer to Multiventing and Vent Terminations section for proper vent configurations.
2. When locating combustion-air and vent terminations, consideration must be given to prevailing winds, location, and other conditions which may cause recirculation of the appliance's own flue products or the flue products of adjacent vents. Recirculation can cause poor combustion, inlet condensate problems, and accelerated corrosion of heat exchangers.
3. Vent termination can not terminate less than 2 ft horizontal and 7 ft above public walkway or where condensate vapor or droplets may be a hazard.

Furnace combustion-air and vent pipe connections must be attached as shown in Fig. 31. Combustion-air intake plug fitting and inducer housing alternate vent cap may need to be relocated in some applications.

**NOTE:** →Slope combustion-air and vent pipes a minimum of 1/4 in. per linear ft with no sags between hangers.

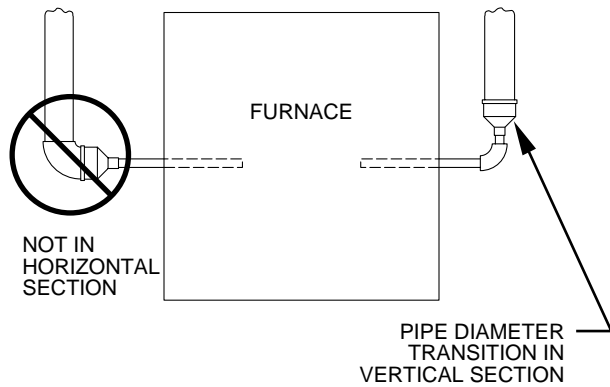

A93034

**Fig. 29—Combustion-Air and Vent Pipe Diameter Transition Location and Elbow Configuration**

**NOTE:** Select 1 vent pipe connection and 1 combustion-air pipe connection.

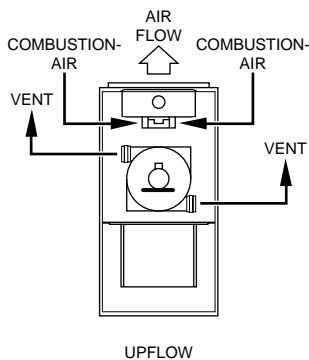

**NOTE:** Select 1 vent pipe connection and 1 combustion-air pipe connection.

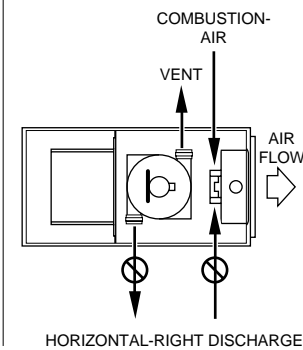
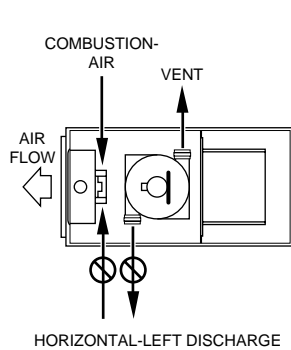
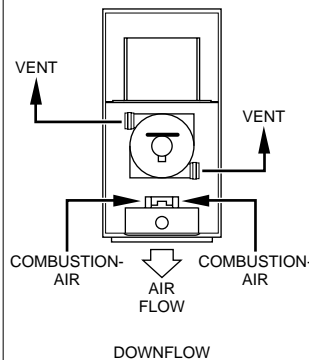

A96187

**Fig. 30—Combustion-Air and Vent Pipe Connections**

**⚠ CAUTION**

When combustion-air pipe is installed above a suspended ceiling, pipe must be insulated with 3/8-in. thick Armaflex-type insulation. Combustion-air pipe should also be insulated when it passes through a warm, humid space.

**⚠ CAUTION**

When vent pipe is exposed to temperatures below freezing, such as when it passes through an unheated space or when a chimney is used as a raceway, pipe must be insulated as shown in Table 7 with Armaflex-type insulation.

**⚠ CAUTION**

Combustion air must not be taken from inside structure because that air is frequently contaminated by halogens, which include fluorides, chlorides, bromides, and iodides. These elements are found in aerosols, detergents, bleaches, cleaning solvents, salts, air fresheners, adhesives, paint, and other household products. Locate combustion-air inlet as far as possible from swimming pool and swimming pool pump house.

Excessive exposure to contaminated combustion air will result in safety and performance related problems.

**⚠ WARNING**

Solvent cements are combustible. Keep away from heat, sparks, and open flame. Use only in well ventilated areas. Avoid breathing in vapor or allowing contact with skin or eyes. Failure to follow this warning could result in fire, property damage, personal injury, or death.

**⚠ WARNING**

All combustion-air and vent pipes must be airtight and watertight. Pipes must also terminate exactly as shown in Fig. 33, 34, 35, 36, or 37. Failure to follow this warning could result in property damage, personal injury, or death.

**NOTE:** The minimum combustion-air and vent pipe length (each) for these furnaces is 5 ft. Short pipe lengths (5-8 ft) may discharge water droplets. These droplets may be undesirable, and a 12-in. minimum offset pipe section is recommended, as shown in Fig. 31, to reduce excessive droplets from exiting vent pipe outlet.

**COMBUSTION-AIR AND VENT PIPE DIAMETER**

Determine combustion-air and vent pipe diameter.

1. Using Table 6, individually determine the combustion-air and vent pipe diameters. Pick the larger of these 2 pipe diameters and use this diameter for both combustion-air and vent pipes.
2. When installing vent systems of short pipe length, use the smallest allowable pipe diameter. Do not use pipe size greater than required or incomplete combustion, flame disturbance, or flame sense lockout may occur.

**NOTE:** Do not count elbows or pipe sections in terminations or within furnace. See shaded areas in Fig. 34, 35, 36, 37, and 38.

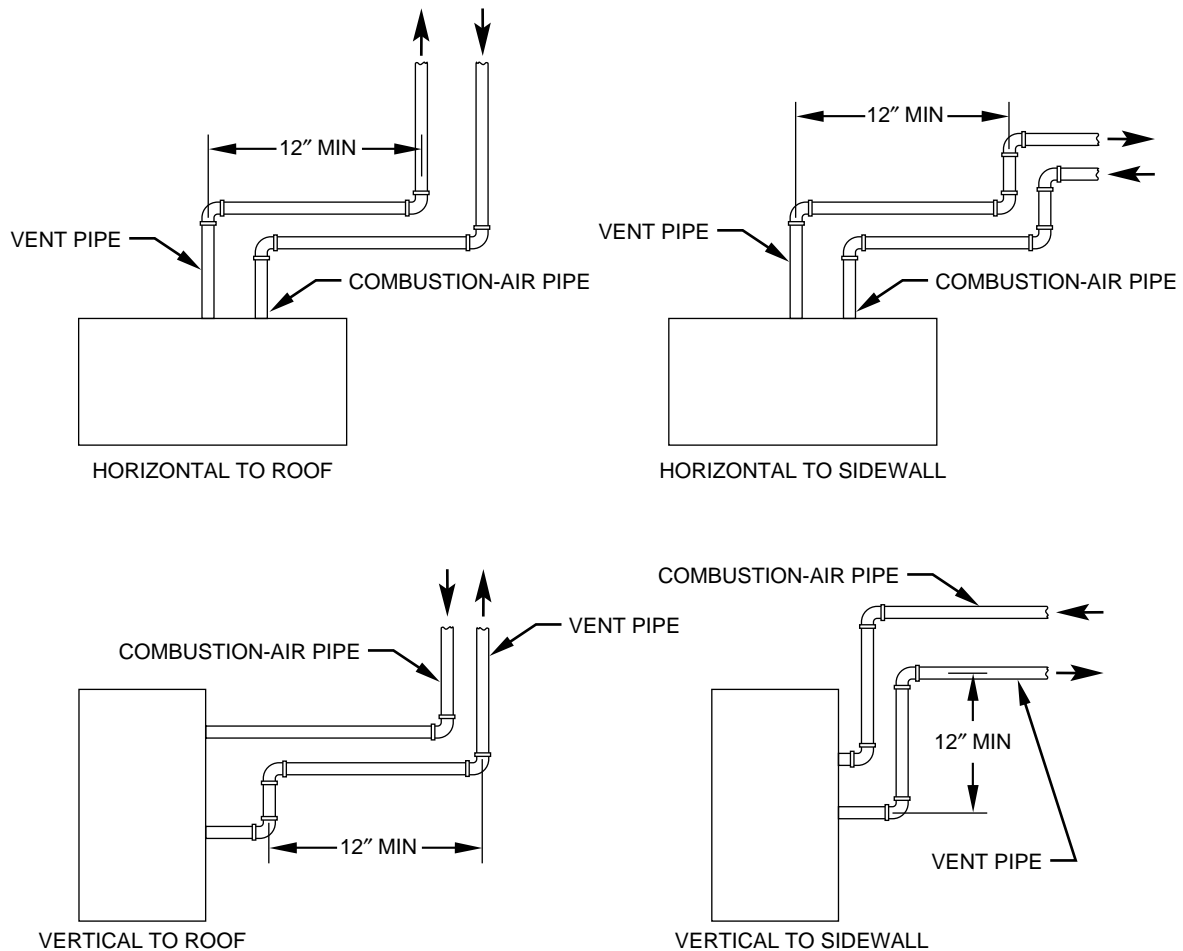

**NOTE:** A 12 in. minimum offset pipe section is recommended with short (5 to 8 ft) vent systems. This recommendation is to reduce excessive condensate droplets from exiting the vent pipe.

**Fig. 31—Short Vent (5 to 8 Ft) System**

A96230

**EXAMPLE:**

An 080-14 size furnace located in Indianapolis, elevation 650 ft above sea level, could be installed in an application requiring 3 elbows and 17 ft of vent pipe, along with 5 elbows and 16 ft of combustion-air pipe. Table 6 indicates this application would allow a 1-1/2-in. diameter vent pipe, but require a 2-in. diameter combustion air pipe (1-1/2-in. pipe is good for 20 ft with 3 elbows, but only 10 ft with 5 elbows). Therefore, 2-in. diameter pipe must be used for both vent and combustion-air pipes since larger required diameter must always be used for both pipes. If same installation were in Albuquerque, elevation 5250 ft above sea level, installation would require 2-in. vent pipe and combustion-air pipe. At 5001- to 6000-ft elevation, 1-1/2-in. pipe is not allowed with 5 elbows, but 2-in. pipe is good for 68 ft with 5 elbows.

**COMBUSTION-AIR AND VENT PIPE ATTACHMENT**

**NOTE:** All pipe joints must be watertight except attachment of combustion-air pipe to inlet housing connection since it may be necessary to remove pipe for servicing.

1. Attach combustion-air pipe as follows:

- a. Determine location of combustion-air intake pipe connection to combustion-air intake housing as shown in Fig. 30 for application.
- b. Reposition combustion-air intake housing plug fitting in appropriate unused intake housing connection.
- c. Insert perforated disk assembly (factory supplied) in intake housing where combustion-air intake pipe will be connected.
- d. Install pipe support (factory-supplied in loose parts bag) into selected furnace casing combustion-air pipe hole. Pipe support should be positioned to bottom of casing hole.
- e. Insert 2-in. diameter pipe into intake housing.
- f. Install casing hole filler cap (factory-supplied in loose parts bag) in unused combustion-air pipe casing hole.

**NOTE:** A 2-in. diameter pipe must be used within the furnace casing. Make all pipe diameter transitions outside furnace casing.

- g. Drill a 1/8-in. hole in 2-in. combustion-air pipe using hole in intake housing as a guide.
- h. Install a field-supplied No. 6 or No. 8 sheet metal screw into combustion-air pipe.

**NOTE:** DO NOT OVERTIGHTEN SCREW. Breakage to intake housing or fitting may cause air leakage to occur.

**Table 6—Maximum Allowable Pipe Length (Ft)**

ALTITUDE	UNIT SIZE	TERMINATION TYPE	PIPE DIAMETER (IN.)*	NUMBER OF 90° ELBOWS					
				1	2	3	4	5	6
0 to 2000	040-14	2 Pipe or 2-In. Concentric	1-1/2	50	45	40	35	30	25
			2	70	70	70	70	70	70
	060-14	2 Pipe or 2-In. Concentric	1-1/2	50	45	40	35	30	25
			2	70	70	70	70	70	70
	080-14 080-20	2 Pipe or 2-In. Concentric	1-1/2	30	25	20	15	10	5
			2	70	70	70	70	70	70
	100-20	2 Pipe or 2-In. Concentric	2	45	40	35	30	25	20
			2-1/2	70	70	70	70	70	70
	120-20	2 Pipe or 3-In. Concentric	2-1/2	10	NA	NA	NA	NA	NA
			3	35	30	15	NA	NA	NA
			3†	70	70	70	70	70	70
ALTITUDE	UNIT SIZE	TERMINATION TYPE	PIPE DIAMETER (IN.)*	NUMBER OF 90° ELBOWS					
				1	2	3	4	5	6
2001 to 3000	040-14	2 Pipe or 2-In. Concentric	1-1/2	45	40	35	30	25	20
			2	70	70	70	70	70	70
	060-14	2 Pipe or 2-In. Concentric	1-1/2	45	40	35	30	25	20
			2	70	70	70	70	70	70
	080-14 080-20	2 Pipe or 2-In. Concentric	1-1/2	26	21	16	11	6	NA
			2	70	70	70	70	70	70
	100-20	2 Pipe or 2-In. Concentric	2	40	35	30	25	20	15
			2-1/2	70	70	70	70	70	70
	120-20	2 Pipe or 3-In. Concentric	3	31	26	12	NA	NA	NA
			3†	63	62	62	61	61	61
ALTITUDE	UNIT SIZE	TERMINATION TYPE	PIPE DIAMETER (IN.)*	NUMBER OF 90° ELBOWS					
				1	2	3	4	5	6
3001 to 4000	040-14	2 Pipe or 2-In. Concentric	1-1/2	42	37	32	27	22	17
			2	70	70	70	70	70	70
	060-14	2 Pipe or 2-In. Concentric	1-1/2	42	37	32	27	22	17
			2	70	70	70	70	70	70
	080-14 080-20	2 Pipe or 2-In. Concentric	1-1/2	25	20	15	10	5	NA
			2	70	70	70	70	70	70
	100-20	2 Pipe or 2-In. Concentric	2	38	33	28	23	18	13
			2-1/2	70	70	70	70	70	70
	120-20	2 Pipe or 3-In. Concentric	3	29	24	10	NA	NA	NA
			3†	59	59	58	57	57	56
ALTITUDE	UNIT SIZE	TERMINATION TYPE	PIPE DIAMETER (IN.)*	NUMBER OF 90° ELBOWS					
				1	2	3	4	5	6
4001 to 5000‡	040-14	2 Pipe or 2-In. Concentric	1-1/2	40	35	30	25	20	15
			2	70	70	70	70	70	70
	060-14	2 Pipe or 2-In. Concentric	1-1/2	40	35	30	25	20	15
			2	70	70	70	70	70	70
	080-14 080-20	2 Pipe or 2-In. Concentric	1-1/2	23	18	13	8	NA	NA
			2	70	70	70	70	70	68
	100-20	2 Pipe or 2-In. Concentric	2	36	31	26	21	16	11
			2-1/2	70	70	70	70	70	70
	120-20	2 Pipe or 3-In. Concentric	3†	56	55	54	53	52	52
	ALTITUDE	UNIT SIZE	TERMINATION TYPE	PIPE DIAMETER (IN.)*	NUMBER OF 90° ELBOWS				
				1	2	3	4	5	6
5001 to 6000‡	040-14	2 Pipe or 2-In. Concentric	1-1/2	37	32	27	22	17	12
			2	70	70	70	70	70	70
	060-14	2 Pipe or 2-In. Concentric	1-1/2	37	32	27	22	17	12
			2	70	70	70	70	70	70
	080-14 080-20	2 Pipe or 2-In. Concentric	1-1/2	22	17	12	7	NA	NA
			2	70	70	70	70	68	63
	100-20	2 Pipe or 2-In. Concentric	2	33	28	23	18	13	8
			2-1/2	70	70	70	70	70	70
	120-20	2 Pipe or 3-In. Concentric	3†	53	52	50	49	48	47

See notes on next page.

**Table 6—Maximum Allowable Pipe Length (Ft) Continued**

ALTITUDE	UNIT SIZE	TERMINATION TYPE	PIPE DIAMETER (IN.)*	NUMBER OF 90° ELBOWS					
				1	2	3	4	5	6
6001 to 7000‡	040-14	2 Pipe or 2-In. Concentric	1-1/2	35	30	25	20	15	10
			2	70	70	68	67	66	64
	060-14	2 Pipe or 2-In. Concentric	1-1/2	35	30	25	20	15	10
			2	70	70	68	67	66	64
	080-14 080-20	2 Pipe or 2-In. Concentric	1-1/2	20	15	10	5	NA	NA
			2	70	70	68	67	62	57
	100-20	2 Pipe or 2-In. Concentric	2	31	26	21	16	11	6
			2-1/2	70	70	68	67	66	64
	120-20	2 Pipe or 3-In. Concentric	3†	49	48	47	45	44	43
	ALTITUDE	UNIT SIZE	TERMINATION TYPE	PIPE DIAMETER (IN.)*	NUMBER OF 90° ELBOWS				
7001 to 8000‡	040-14	2 Pipe or 2-In. Concentric	1-1/2	32	27	22	17	12	7
			2	66	65	63	62	60	59
	060-14	2 Pipe or 2-In. Concentric	1-1/2	32	27	22	17	12	7
			2	66	65	63	62	60	59
	080-14 080-20	2 Pipe or 2-In. Concentric	1-1/2	18	13	8	NA	NA	NA
			2	66	65	63	62	57	52
	100-20	2 Pipe or 2-In. Concentric	2	29	24	19	14	9	NA
			2-1/2	66	65	63	62	60	59
	120-20	2 Pipe or 3-In. Concentric	3†	46	44	43	41	40	38
	ALTITUDE	UNIT SIZE	TERMINATION TYPE	PIPE DIAMETER (IN.)*	NUMBER OF 90° ELBOWS				
8001 to 9000‡	040-14	2 Pipe or 2-In. Concentric	1-1/2	30	25	20	15	10	5
			2	62	60	58	56	55	53
	060-14	2 Pipe or 2-In. Concentric	1-1/2	30	25	20	15	10	5
			2	62	60	58	56	55	53
	080-14 080-20	2 Pipe or 2-In. Concentric	1-1/2	17	12	7	NA	NA	NA
			2	62	60	58	56	51	46
	100-20	2 Pipe or 2-In. Concentric	2	27	22	17	12	7	NA
			2-1/2	62	60	58	56	55	53
	120-20	2 Pipe or 3-In. Concentric	3†	43	41	39	37	35	34
	ALTITUDE	UNIT SIZE	TERMINATION TYPE	PIPE DIAMETER (IN.)*	NUMBER OF 90° ELBOWS				
9001 to 10000‡	040-14	2 Pipe or 2-In. Concentric	1-1/2	27	22	17	12	7	NA
			2	57	55	53	51	49	47
	060-14	2 Pipe or 2-In. Concentric	1-1/2	27	22	17	12	7	NA
			2	57	55	53	51	49	47
	080-14 080-20	2 Pipe or 2-In. Concentric	1-1/2	15	10	5	NA	NA	NA
			2	57	55	53	51	46	41
	100-20	2 Pipe or 2-In. Concentric	2	24	19	14	9	NA	NA
			2-1/2	57	55	53	51	49	47
	120-20	2 Pipe or 3-In. Concentric	3†	39	37	35	33	31	29

\* Disk usage—Unless otherwise stated, use perforated disk assembly (factory-supplied in loose parts bag).

† Wide radius elbow.

‡ Vent sizing for Canadian installations over 4500 ft (1370m) above sea level are subject to acceptance by the local authorities having jurisdiction.

NA—Not Allowed; pressure switch will not make.

**NOTES:**

1. Do not use pipe size greater than those specified in table or incomplete combustion, flame disturbance, or flame sense lockout may occur.
2. Size both the combustion-air and vent pipe independently, then use the larger diameter for both pipes.
3. Assume two 45° elbows equal one 90° elbow. Long radius elbows are desirable and may be required in some cases.
4. Elbows and pipe sections within the furnace casing and at the vent termination should not be included in vent length or elbow count.
5. The minimum pipe length is 5 ft for all applications.

**NOTE:** Do not attach combustion-air intake pipe permanently to combustion-air intake housing since it may be necessary to remove pipe for service of ignitor or flame sensor.

#### COMBUSTION-AIR INTAKE HOUSING PLUG FITTING

The combustion-air intake plug fitting must be installed in unused combustion-air intake housing. This fitting must be attached by using RTV sealant, or by drilling a 1/8-in. hole in fitting, using hole in intake housing as a guide. Install a field-supplied No. 6 or No. 8 sheet metal screw.

**NOTE:** DO NOT OVERTIGHTEN SCREW. Breakage to intake housing or fitting may cause air leakage to occur.

A plugged drain connection has been provided on this fitting for use when moisture is found in combustion-air intake pipe and combustion box.

**NOTE:** Moisture in combustion-air intake may be result of improper termination. Ensure combustion-air intake pipe is similar to that shown in Fig. 33, 34, 35, 36, or 37 so it will not be susceptible to areas where light snow or other sources of moisture could be pulled in.

If use of this drain connection is desired, drill out fitting's tap plug with a 3/16-in. drill and connect a field-supplied 3/8-in. tube. This tube should be routed to open condensate drain for furnace and A/C (if used), and should be trapped. (See Fig. 32.)

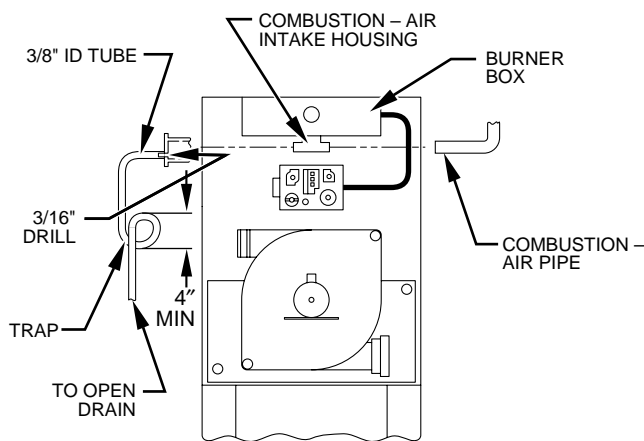

**Fig. 32—Intake Housing Plug Fitting Drain** A93035

2. Attach vent pipe as follows:
  - a. Determine location of vent pipe connection to inducer housing as shown in Fig. 30 for application.
  - b. Reposition elastomeric (rubber) inducer housing outlet cap and clamp to appropriate unused inducer housing connection. Tighten clamp.

**⚠ WARNING**

Inducer housing outlet cap must be installed and fully seated against inducer housing. Clamp must be tightened to prevent any condensate leakage. Failure to follow this warning could result in electrical shock, fire, personal injury, or death.

- c. Install pipe support (factory-supplied in loose parts bag) into selected furnace casing vent pipe hole. Pipe support should be positioned to bottom of casing hole.
- d. Be certain that mating surfaces of inducer housing connection, elastomeric coupling, and 2-in. diameter vent pipe are clean and dry. Assemble the elastomeric (rubber) vent coupling (with 2 loose clamps) onto inducer housing connection. Insert the 2-in. diameter vent pipe through the

elastomeric (rubber) coupling and fully into inducer housing connection until it bottoms on the internal stop. Tighten both clamps to secure the pipe to inducer housing. Tighten the clamp screws to 15 in.-lb. of torque.

- e. Install casing hole filler cap (factory-supplied in loose parts bag) in unused combustion-air pipe casing hole.

**⚠ WARNING**

Vent pipe must be installed and fully seated against inducer housing internal stop. Clamp must be tightened to prevent any condensate leakage. Failure to follow this warning could result in electrical shock, fire, personal injury, or death.

**NOTE:** A 2-in. diameter pipe must be used within the furnace casing. Make all pipe diameter transitions outside furnace casing.

3. Working from furnace to outside, cut pipe to required length(s).
4. Deburr inside and outside of pipe.
5. Chamfer outside edge of pipe for better distribution of primer and cement.
6. Clean and dry all surfaces to be joined.
7. Check dry fit of pipe and mark insertion depth on pipe.

**NOTE:** It is recommended that all pipes be cut, prepared, and preassembled before permanently cementing any joint.

8. After pipes have been cut and preassembled, apply generous layer of cement primer to pipe fitting socket and end of pipe to insertion mark. Quickly apply approved cement to end of pipe and fitting socket (over primer). Apply cement in a light, uniform coat on inside of socket to prevent buildup of excess cement. Apply second coat.
9. While cement is still wet, twist pipe into socket with 1/4 turn. Be sure pipe is fully inserted into fitting socket.
10. Wipe excess cement from joint. A continuous bead of cement will be visible around perimeter of a properly made joint.
11. Handle pipe joints carefully until cement sets.
12. Support combustion-air and vent piping a minimum of every 5 ft (3 ft for SDR-21 or -26 PVC) using perforated metal hanging strap.
13. Slope combustion-air and vent pipes toward furnace a minimum of 1/4 in. per linear ft with no sags between hangers.
14. Use appropriate methods to seal openings where vent and combustion-air pipes pass through roof or sidewall.

#### Step 3—Concentric Vent and Combustion-Air Termination Kit Installation

**NOTE:** If these instructions differ from those packaged with termination kit, follow kit instructions.

Combustion-air and vent pipes must terminate outside structure. A factory accessory termination kit must be installed in 1 of the installations shown in Fig. 33, 34, 35, 36, or 37. Four termination kits are available.

1. The 2-in. termination bracket kit is for 1-in., 1-1/2 in., and 2-in. diameter 2-pipe termination systems.
2. The 3-in. termination bracket kit is for 2-1/2 in. and 3-in. diameter 2-pipe termination systems.
3. The 2-in. concentric vent/air termination kit is for 1-in., 1-1/2 in., 2-in., and 2-1/2 in. diameter pipe systems when single penetration of wall or roof is desired.
4. The 3-in. concentric vent/air termination kit is for 2-1/2 in. and 3-in. diameter pipe systems when single penetration of wall or roof is desired.

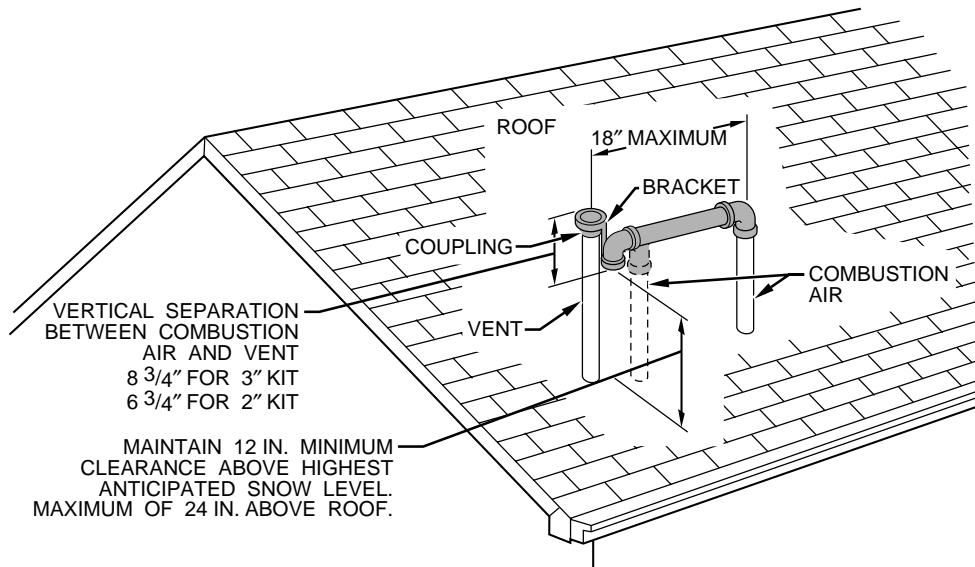

**Fig. 33—Roof Termination (Preferred)**

A87224

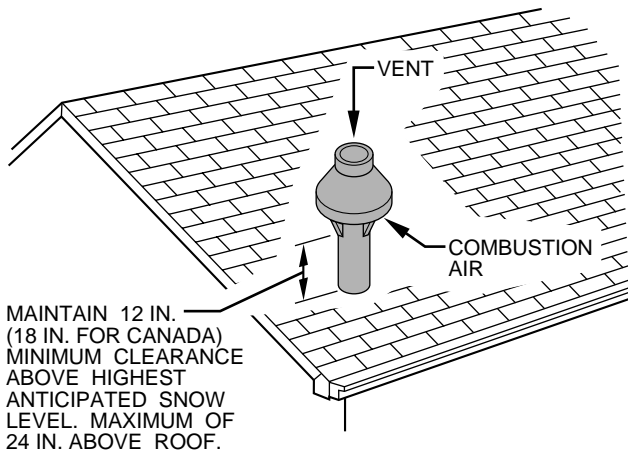

**Fig. 34—Concentric Vent and Combustion-Air Roof Termination (Preferred)**

A93054

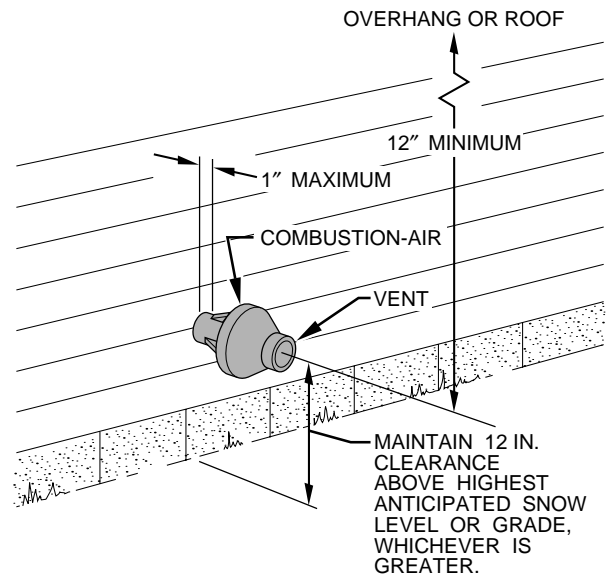

**Fig. 35—Concentric Vent and Combustion-Air Side Termination**

A93055

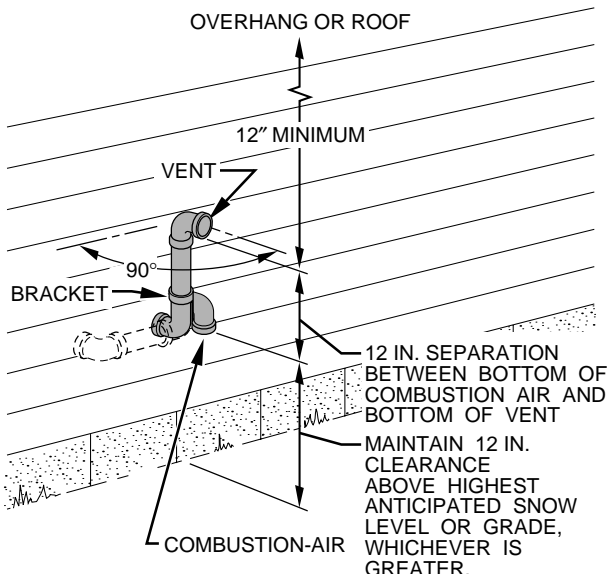

**Fig. 36—Sidewall Termination of 12 in. or More**

A87225

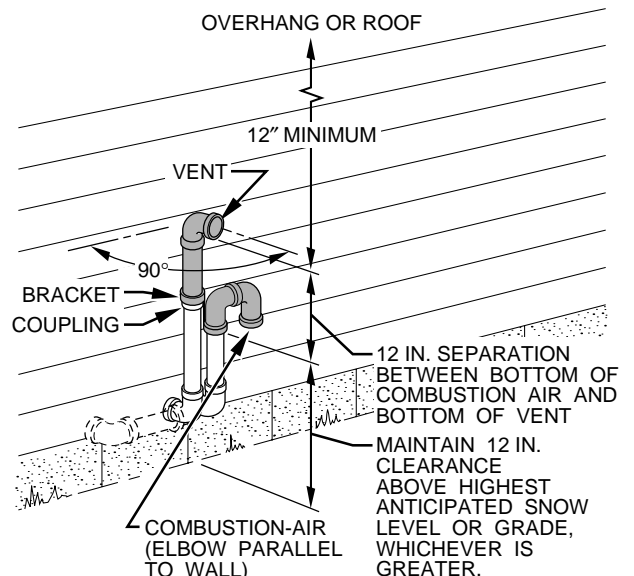

**Fig. 37—Sidewall Termination of Less than 12 in.**

A87226

**Table 7—Maximum Allowable Exposed Vent Pipe Length (Ft) With Insulation in Winter Design Temperature Ambient\***

UNIT SIZE	WINTER DESIGN TEMPERATURE (°F)	MAXIMUM PIPE DIAMETER (IN.)	INSULATION THICKNESS (IN.)†				
			0	3/8	1/2	3/4	1
040-14	20	2	21	37	42	50	57
	0	2	10	22	25	30	35
	-20	2	5	14	17	21	25
060-14	20	2	30	55	61	70	70
	0	2	16	33	38	46	53
	-20	2	9	23	26	33	38
080-14 080-20	20	2	37	65	70	70	70
	0	2	20	39	45	55	63
	-20	2	11	27	31	39	45
100-20	20	2-1/2	41	70	70	70	70
	0	2-1/2	21	42	48	59	68
	-20	2-1/2	11	28	33	41	49
120-20	20	3	49	70	70	70	70
	0	3	26	51	58	70	70
	-20	3	15	35	40	50	59

\* Pipe length (ft) specified for maximum pipe lengths located in unconditioned spaces. Pipes located in unconditioned space cannot exceed total allowable pipe length as specified in Table 6.

† Insulation thickness based on R value of 3.5 per in.

**NOTE:** Shaded parts in Fig. 33, 34, 35, 36, and 37 are considered to be terminations. These components should NOT be counted when determining pipe diameter. Roof termination is preferred since it is less susceptible to damage, has reduced chances to intake contaminants, and has less visible vent vapors. (See Fig. 33 or 34.) Sidewall termination may require sealing or shielding of building surfaces with a corrosive resistance material due to corrosive combustion products of vent system.

**EXTENDED EXPOSED SIDEWALL PIPES**

Sidewall combustion-air and vent pipe terminations may be extended beyond area shown in Fig. 36 or 37 in outside ambient by insulating pipes as indicated in Table 7.

1. Determine combustion-air and vent pipe diameters, as stated above, using total pipe length and number of elbows.
2. Using winter design temperature (used in load calculations), find appropriate temperature for your application and furnace model.
3. Determine required insulation thickness for exposed pipe lengths.

**NOTE:** Pipe length (ft) specified for maximum pipe lengths located in unconditioned spaces cannot exceed total allowable pipe length as specified in Table 6.

**TWO-PIPE TERMINATION KIT**

1. Determine location for termination.

Consideration of the following should be made when determining an appropriate location for termination kit.

- a. Comply with all clearance requirements as stated in Table 5.
- b. Termination kit should be positioned where vent vapors will not damage plants/shrubs or air conditioning equipment.
- c. Termination kit should be positioned so it will not be affected by wind eddy (such as inside building corners) or accumulation of airborne leaves or light snow, or allow recirculation of flue gases.
- d. Termination kit should be positioned where it will not be damaged by or subjected to foreign objects, such as stones, balls, etc.

- e. Termination kit should be positioned where vent vapors are not objectionable.

2. Cut 2 holes, 1 for each pipe, of appropriate size for pipe size being used.
3. Loosely install elbow in bracket and place assembly on combustion-air pipe.

**Roof terminations**—Loosely install pipe coupling on properly cut vent pipe. Coupling must be positioned so bracket will mount as shown in Fig. 33.

For applications using combustion-air pipe option indicated by dashed lines in Fig. 33, install 90° street elbow into 90° elbow, making U-fitting. A 180° U-fitting may be used.

**Sidewall terminations**—Install bracket as shown in Fig. 36 or 37.

For applications using vent pipe option indicated by dashed lines in Fig. 36, rotate vent elbow 90° from position shown in Fig. 36.

4. Disassemble loose pipe fittings. Clean and cement using same procedures as used for system piping.
5. Check required dimensions as shown in Fig. 33, 36, or 37.

**CONCENTRIC VENT/AIR TERMINATION KIT**

1. Determine location for termination.

Consideration of the following should be made when determining an appropriate location for termination kit.

- a. Comply with all clearance requirements as stated in Table 5.
- b. Termination kit should be positioned where vent vapors will not damage plants/shrubs or air conditioning equipment.
- c. Termination kit should be positioned so it will not be affected by wind eddy (such as inside building corners) or accumulation of airborne leaves or light snow, or allow recirculation of flue gases.
- d. Termination kit should be positioned where it will not be damaged by or subjected to foreign objects, such as stones, balls, etc.
- e. Termination kit should be positioned where vent vapors are not objectionable.

2. Cut one 4-in. diameter hole for 2-in. kit, or one 5-in. diameter hole for 3-in. kit.
3. Loosely assemble concentric vent/air termination components together using instructions in kit.
4. Slide assembled kit with rain shield REMOVED through hole.

**NOTE:** Do not allow insulation or other materials to accumulate inside of pipe assembly when installing it through hole.

**Roof terminations**—Locate assembly through roof to appropriate height as shown in Fig. 34.

**Sidewall terminations**—Locate assembly through sidewall with rain shield positioned no more than 1-in. from wall as shown in Fig. 34 .

5. Disassemble loose pipe fittings. Clean and cement using same procedures as used for system piping.
6. Check required dimensions as shown in Fig. 34 or 35.

#### Step 4—Multiventing and Vent Terminations

When 2 or more 58MVP Furnaces are vented near each other, each furnace must be individually vented. NEVER common vent or breach vent 58MVP furnaces. When 2 or more 58MVP furnaces are vented near each other, 2 vent terminations may be installed as shown in Fig. 38, 39, 40, 41, or 42, but next vent termination must be at least 36 in. away from first 2 terminations. It is important that vent terminations be made as shown to avoid recirculation of flue gases. Dimension "A" in Fig. 38, 39, 40, 41, and 42 represents distance between pipes or rain shields, as touching or 2-in. maximum separation.

### CONDENSATE DRAIN

#### Step 1—General

Condensate trap is shipped installed in the blower shelf and factory connected for UPFLOW applications. Condensate trap must be RELOCATED for use in DOWNFLOW and HORIZONTAL applications.

Condensate trap MUST be used for all applications.

An external trap is not required when connecting the field drain to this condensate trap.

The field drain connection (condensate trap or drain tube coupling) is sized for 1/2-in. CPVC, 1/2-in. PVC, or 5/8-in. ID tube connection.

Drain pipe and fittings must conform to ANSI standards and ASTM D1785 or D2846. CPVC or PVC cement and primer must conform to ASTM D2564 or F493. In Canada, use CSA or ULC certified schedule 40 CPVC or PVC drain pipe, fittings, and cement.

When a condensate pump is required, select a pump which is approved for condensing furnace applications. To avoid condensate spillage, select a pump with an overflow switch.

Furnace condensate is mildly acidic, typically in the pH range of 3.2 to 4.5. Due to corrosive nature of this condensate, a condensate pH neutralizing filter may be desired. Check with local authorities to determine if a pH neutralizer is required.

#### Step 2—Application

The furnace, A/C, and humidifier drains may be combined and drained together. The A/C drain must have an external, field-supplied trap prior to the furnace drain connection. All drain connections (furnace, A/C, or humidifier) must be terminated into an open or vented drain as close to the respective equipment as possible to prevent siphoning of the equipment's drain.

See Fig. 43 for example of possible field drain attachment using 1/2-in. CPVC or PVC tee for vent and A/C or humidifier drain connection.

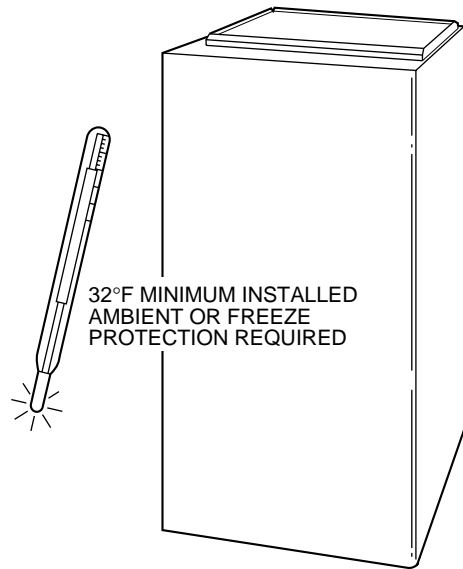

A93058

#### ⚠ CAUTION

Unit must not be installed, operated, and then turned and left off in an unoccupied structure during cold weather when temperature drops to 32°F or below unless drain trap and drain line have adequate freeze protection. See Service and Maintenance Instructions for winterizing procedure.

Outdoor draining of the furnace is permissible if allowed by local codes. Caution should be taken when freezing ambient may freeze drain pipe and prohibit draining.

#### ⚠ WARNING

Caution should be taken to prevent draining where slippery conditions may cause personal injuries. Excessive condensate draining may cause saturated soil conditions which may result in damage to plants.

#### Step 3—Condensate Drain Protection

Freezing condensate left in condensate trap and drain line may cause cracks, and possible water damage may occur. If freeze protection is required, use condensate freeze protection accessory or equivalent 3 to 6 watt per ft at 120v and 40°F self-regulating, shielded, and waterproof heat tape. See Installation Instructions supplied with accessory or heat tape manufacturer's recommendations.

1. Fold heat tape in half and wrap on itself 3 times.
2. Locate heat tape between sides of condensate trap back. (See Fig. 44.)
3. Use wire ties to secure heat tape in place. Wire ties can be positioned in notches of condensate trap sides. (See Fig. 44.)
4. Wrap field drain pipe with remaining heat tape, approximately 1 wrap per ft.
5. When using field-supplied heat tape, follow heat tape manufacturer's instructions for all other installation guidelines.

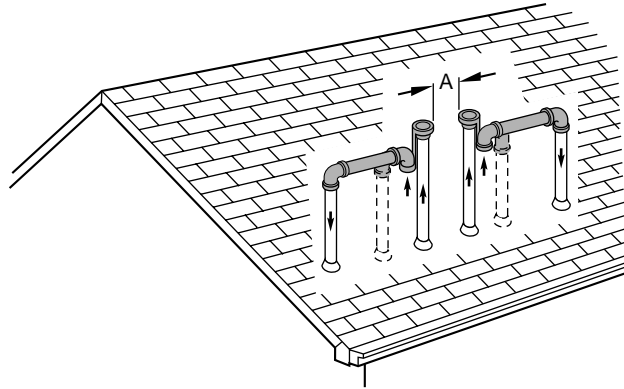

A96128

**Fig. 38—Rooftop Termination (Dimension "A" is Touching or 2-In. Maximum Separation)**

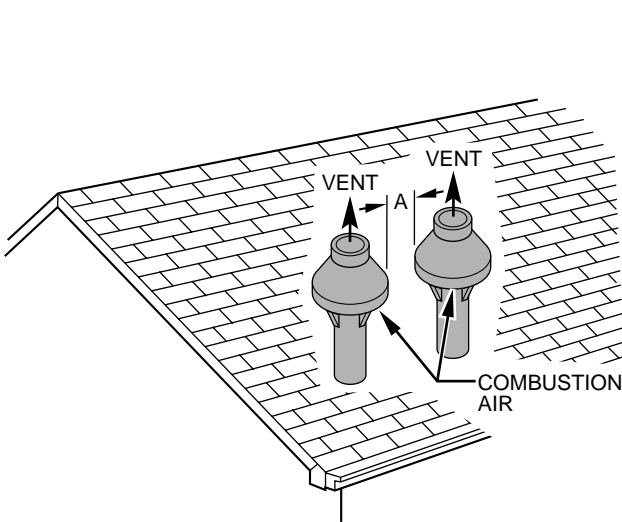

A93056

**Fig. 39—Concentric Vent and Combustion-Air Roof Termination (Dimension "A" is Touching or 2-In. Maximum Separation)**

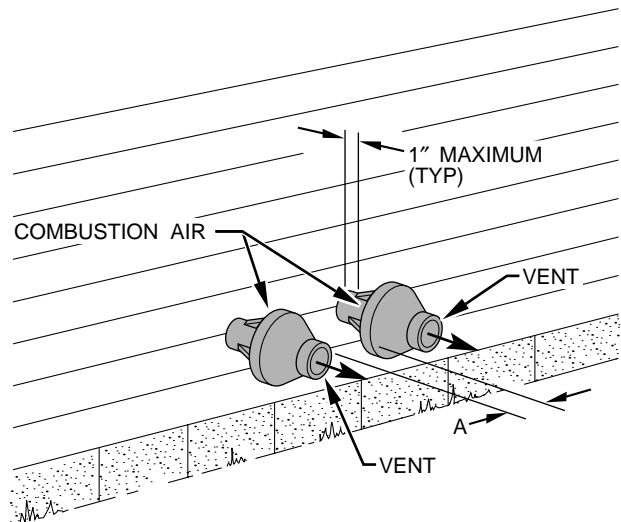

A93057

**Fig. 40—Concentric Vent and Combustion-Air Side Termination (Dimension "A" is Touching or 2-In. Maximum Separation)**

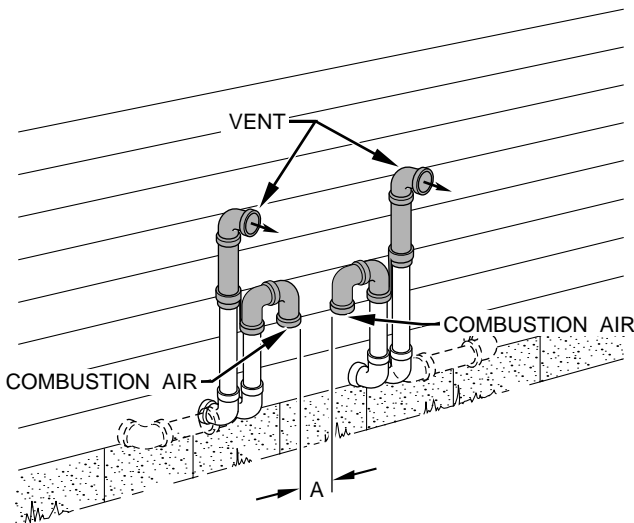

A96129

**Fig. 41—Sidewall Termination of 12 in. or Less (Dimension "A" is Touching or 2-In. Maximum Separation)**

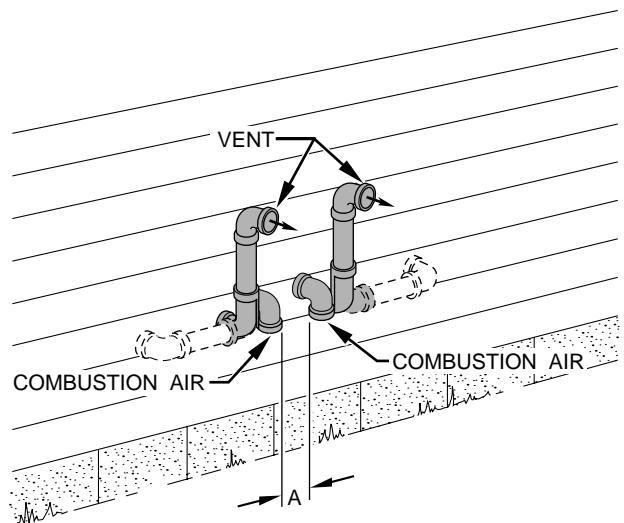

A96130

**Fig. 42—Sidewall Termination of More Than 12 in. (Dimension "A" is Touching or 2-In. Maximum Separation)**

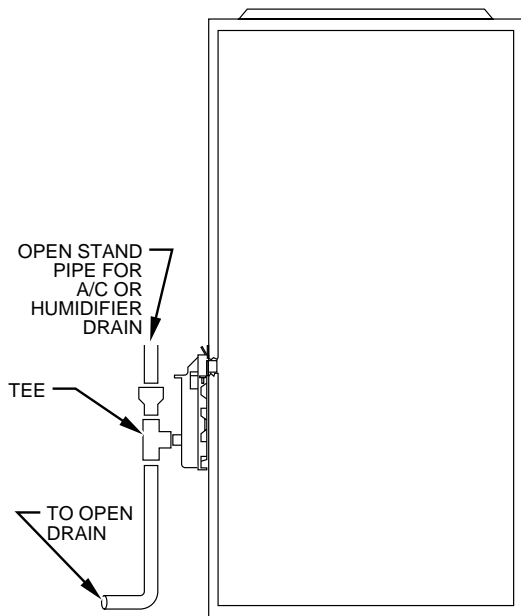

A94054

**Fig. 43—Example of Field Drain Attachment**

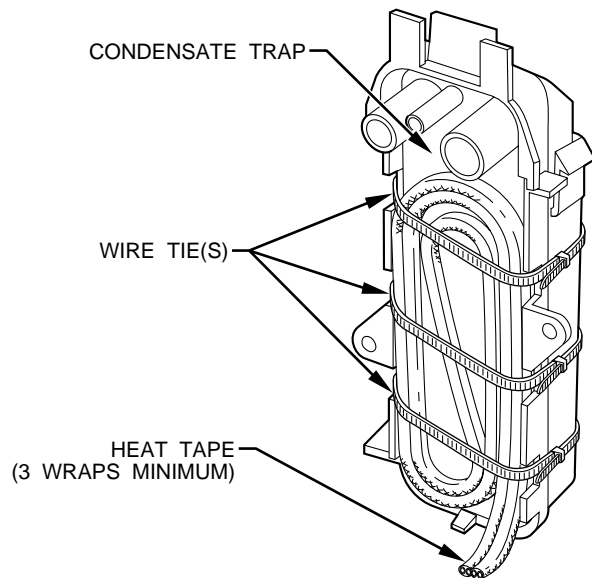

A93036

**Fig. 44—Condensate Trap Heat Tape**

**SEQUENCE OF OPERATION**

**⚠ CAUTION**

Furnace control must be grounded for proper operation, or control will lock out. Control is grounded through green wire routed to gas valve and burner box screw.

Using schematic diagram (see Fig. 24), follow sequence of operation through different modes. This furnace has a new control system. Read and follow wiring diagram carefully.

**NOTE:** If 115-v power supply to furnace or blower access panel switch is interrupted during a call for heat, blower operates at low-heat speed for 60 sec when power is restored before heating cycle is resumed.

**Step 1—Self-Test Mode**

The control center goes through a brief self-test whenever 115-v or 24-v power is interrupted. The self-test takes approximately 2 sec to complete. After power is restored, red (microprocessor) LED

briefly comes on. Then green LED comes on for 1 sec, followed by 1 sec where both yellow and green LEDs are on. During this time, the microprocessor is checking itself.

**Step 2—Heating Mode**

When thermostat calls for heat, R-W/W1 circuit closes.

1. **Prepurge period**—The inducer motor is turned on and slowly comes up to speed. When low-pressure switch closes, inducer motor RPM is noted by microprocessor, and a 25 sec prepurge period begins. The RPM is used to evaluate vent system resistance. This evaluation is then used to determine required RPM necessary to operate inducer in low-heat mode.

**NOTE:** The heat cycle can start in either high or low heat. If a high-heat cycle is initiated, the inducer continues increasing its speed after low-pressure switch closes. When high-pressure switch closes, inducer motor RPM is noted by microprocessor before the 25 sec prepurge period begins. The RPM is used to evaluate vent system resistance. This evaluation is then used to determine required RPM necessary to operate inducer in high-heat mode.

2. **Humidifier (HUM)**—The HUM terminal is energized after the inducer prepurge period is completed.
3. **Ignitor warm up**—At end of prepurge period, the hot surface ignitor (HSI) is energized for a 17-sec HSI warm-up period.
4. **Ignition sequence**—After HSI ignitor warm-up period is completed, the gas valve opens, permitting gas flow to burners where it is ignited. After 5 sec, the HSI is de-energized, and a 2-sec flame-sensing period begins.

**NOTE:** The initial heat mode after 115-v or 24-v power interruption will be LOW HEAT. Low heat remains energized for 16 minutes before high heat is initiated, providing thermostat is still calling for heat.

After initial cycle, the microprocessor evaluates the length of low- and high-heat operating times and calculates optimum length of low and high heat for next heat cycle. This accommodates the heat load requirement seen as a result of thermostat operating time.

5. **Flame sensing**—When burner flame is sensed, the control center holds gas valve open and begins blower on delay period.

**NOTE:** Ignition sequence repeats 3 additional times before a lockout occurs. Lockout automatically resets after 3 hr, or can be manually reset by turning 115-v or 24-v power off (not at thermostat) for 3 sec minimum, then turning on again.

6. **Inducer speed operation**—If cycle starts in low heat, inducer speed reduces slightly after flame sense. If cycle starts in high heat, inducer speed increases 15 sec after flame sense. The reduction in speed in low heat is to optimize combustion for maximum efficiency.
7. **Blower on delay**—The blower starts 60 sec after flame sense if cycle started in low heat or 35 sec after flame sense if cycle started in high heat.

**NOTE:** The blower starts at approximately 400-500 RPM. After 20 sec, the motor is turned off for 1/10 of a sec where a coast down calibration is done to evaluate resistance of the conditioned air duct system. The microprocessor then determines blower RPM required to provide proper airflow for heating mode.

8. **Electronic Air Cleaner**—The EAC-1 terminal is energized whenever the blower operates.
9. **Blower off delay**—When thermostat is satisfied, the R-W/W1 signal is terminated, de-energizing gas valve (stopping gas flow to burners), and HUM terminal is de-energized.

The blower reduces its speed to low-heat RPM. The blower and EAC remain operating 90, 135, 180, or 225 sec (depending on blower off time selection). The furnace is factory set for a 90-sec blower off delay.

10. **Post purge**—The inducer continues operating for 15 sec after gas valve is de-energized.

### Step 3—Heating Mode—Two Stage

The control center provides 2-stage heating using a single-stage thermostat. The control center maximizes comfort while optimizing efficiency to meet the demands of conditioned area when a thermostat R-W/W1 signal is received.

If thermostat control over furnace staging is desired, a 2-stage thermostat can be used. When control center receives a thermostat R-W/W1 and R-W2 signal, high heat is energized and when a R-W/W1 signal alone is received, low heat is energized. This method overrides microprocessor control of high or low heat.

**NOTE:** When using 2-stage thermostat operation with R-W/W1 and R-W2 signals, setup switch SW-2 MUST be in ON position.

The heat cycle operates as stated in Heating Mode section.

To allow for greater comfort, 2-stage thermostat control is recommended when zone systems are used.

### Step 4—Emergency Heat Mode

**NOTE:** The furnace should not be operated in emergency heat mode for extended periods of time. Operation is only recommended to provide heat until replacement components can be obtained or fault resolved.

In this mode, the microprocessor is bypassed and motors operate at full speed with high-heat operation. The heat exchangers, motors, and electronics can be overstressed and may reduce the life of components if operated for an extended period.

**NOTE:** No safeties are bypassed when using emergency heat mode.

Emergency heat mode can be selected using setup switch SW-4. SW-4 should be used when a fault condition exists or difficult to resolve problems occur. This allows heating until fault can be corrected.

In emergency heat mode, the normal heat mode outlined in Heating Mode section is not followed. The following sequence will occur:

When thermostat calls for heat, the R-W/W-1 circuits close.

1. **Prepurge period**—The inducer motor is turned on IMMEDIATELY operating at maximum speed, closing low- and high-pressure switches. Prepurge begins 25 sec after high-pressure switch closes.
2. **Blower on**—The blower motor is turned on IMMEDIATELY and slowly increases to maximum speed as soon as a call for heat is received. No blower calibration occurs.
3. **Electronic Air Cleaner**—The EAC-1 terminal does not operate in emergency heat mode.
4. **Humidifier**—The HUM terminal is energized IMMEDIATELY.
5. **Ignitor warm up**—The HSI is energized for a 17 sec warm-up period after prepurge period is completed.
6. **Ignition sequence**—After HSI warm-up period has completed, the gas valve is energized, permitting gas flow to burners where it is ignited. After 5 sec, the HSI is de-energized, and a 2-sec flame-sensing period begins.

**NOTE:** Emergency heat mode only operates in high heat.

7. **Flame sensing**—When burner flame is sensed, control center holds gas valve open. If burner flame is not sensed, control

center de-energizes gas valve and ignition sequence is repeated.

**NOTE:** Ignition sequence repeats 3 additional times before lockout occurs. Lockout automatically resets after 3 hr, or can be manually reset by turning 115-v or 24-v power off (not at thermostat) for 3 sec minimum, then turning on again. Fault codes will not flash in emergency heat mode.

8. **Blower off delay**—When thermostat is satisfied, the R-W/W1 signal is terminated, de-energizing gas valve (stopping gas flow to burners), and HUM terminal is de-energized. The blower stops immediately.

9. **Post purge**—Post purge does NOT occur. The inducer stops immediately.

### Step 5—Cooling Mode

#### SINGLE-SPEED APPLICATIONS

When thermostat calls for cooling, the R-G and R-Y/Y2 circuits close.

1. **Cooling unit**—The cooling unit starts when thermostat R-Y signal is received.
2. **Blower on**—The control center starts blower immediately when it receives an R-Y/Y2 and R-G signal. The blower starts at approximately 400-500 RPM. After 20 sec, the blower is turned off for 1/10 of a sec where a coast down calibration is done to evaluate resistance of the conditioned air duct system. The microprocessor then determines blower RPM required to provide selected cooling airflow.

**NOTE:** In cooling mode, the microprocessor adjusts blower RPM to operate at 400 CFM per ton as selected on A/C setup switches. Airflow will be reduced to 315 CFM per ton when a dehumidification demand exists. See Air Conditioning Setup Switches section. There is also a chart on wiring diagram. (See Fig. 24.)

**NOTE:** If Y/Y2 thermostat lead is not connected to furnace control center, blower motor operates in continuous fan speed and indoor coil freeze-up may occur.

3. **Electronic Air Cleaner**—The EAC-1 terminal is energized whenever blower operates.
4. **Cooling unit**—The cooling unit stops when thermostat R-Y signal is terminated.
5. **Blower off delay**—When thermostat is satisfied, the R-Y/Y2 and R-G signals are terminated, and blower remains operating for 90 sec. The blower airflow will drop by 21 percent during the off-delay period when the DE jumper is connected. The DE jumper is only removed to enable the DEHUM input for use with a thermidistat or humidistat for dehumidification purposes.

#### TWO-SPEED APPLICATIONS

For details on 2-speed cooling applications, refer to Fig. 45.

### Step 6—Heat Pump Mode

#### SINGLE-SPEED APPLICATIONS

When furnace is operating in heat pump heating mode, R-Y/Y2 and R-G circuits are closed energizing heat pump, and blower operates at cooling speed. When heat pump defrost is required, R-W/W1 circuits close starting gas heat cycle, and blower adjusts to low-heat speed.

1. **Prepurge period**—The inducer motor is turned on and slowly comes up to speed. When low-pressure switch closes, inducer motor RPM is noted by microprocessor, and a 25 sec prepurge period begins. The RPM is used to evaluate vent system resistance. This evaluation is then used to determine required RPM necessary to operate inducer in low-heat mode.

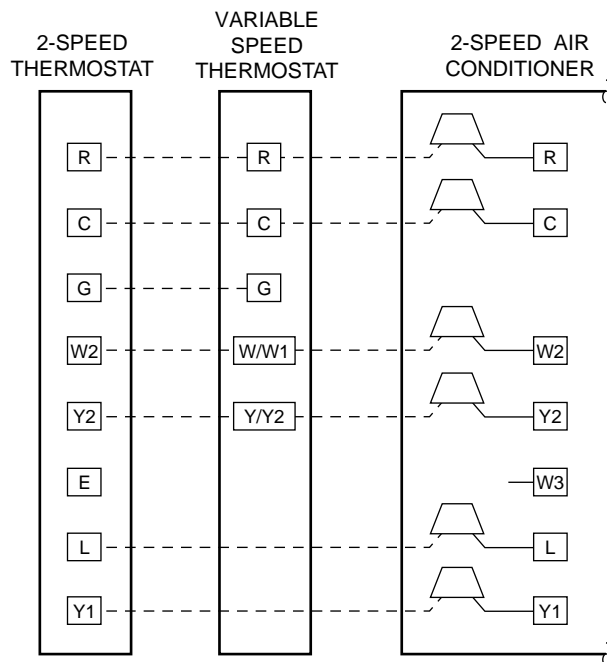

A94302

**Fig. 45—Wiring Schematic for 2-Speed Cooling Applications**

**NOTE:** The heat cycle can start in either high or low heat. If a high-heat cycle is initiated, inducer continues increasing its speed after low-pressure switch closes. When high-pressure switch closes, inducer motor RPM is noted by microprocessor before the 25 sec prepurge period begins. The RPM is used to evaluate vent system resistance. This evaluation is used to determine required RPM necessary to operate inducer in high-heat mode.

2. **Humidifier**—The HUM terminal is energized after inducer prepurge period is completed.
3. **Ignitor warm up**—After prepurge period, HSI is energized for 17 sec.
4. **Ignition sequence**—After HSI warm-up period is completed, the gas valve is energized, permitting gas flow to the burners where it is ignited. After 5 sec, the HSI is de-energized, and a 2-sec flame-sensing period begins.
5. **Flame sensing**—When burner flame is sensed, control center holds gas valve open.  
If burner flame is not sensed, control center de-energizes gas valve, and ignition sequence is repeated.
6. **Blower off period**—Ten sec after gas valve is energized, the blower stops for 25 sec to allow heat exchangers to warm up.
7. **Blower on delay**—After blower off period, blower starts.

**NOTE:** The blower starts at approximately 400-500 RPM. After 20 sec, the motor is turned off for 1/10 of a sec where a coast down calibration is done to evaluate resistance of the conditioned air duct system. The microprocessor then determines blower RPM required to provide proper airflow for heating mode.

8. **Electronic Air Cleaner**—The EAC-1 terminal is energized whenever blower operates.
9. **Inducer speed operation**—If cycle starts in low heat, inducer speed reduces slightly after the flame sense. If cycle starts in high heat, inducer speed increases 15 sec after flame sense. The reduction in speed in low heat is to optimize combustion for maximum efficiency.

10. **Call for heat terminated**—When the call for heat is satisfied, the R-W/W1 signal is terminated, de-energizing gas valve (stopping gas flow to burners), and HUM terminal is de-energized.
  - a. **R-W/W1 signal terminated with R-Y/Y2 and R-G still present**—The blower changes its speed to cooling RPM.
  - b. **R-W/W1 with R-Y/Y2 and R-G signals terminated**—The blower continues to operate completing a normal heating blower off delay.
11. **Post purge**—The inducer continues operating for 15 sec after gas valve is de-energized.

#### TWO-SPEED APPLICATIONS

For details on 2-speed heat pump applications, refer to Fig. 46.

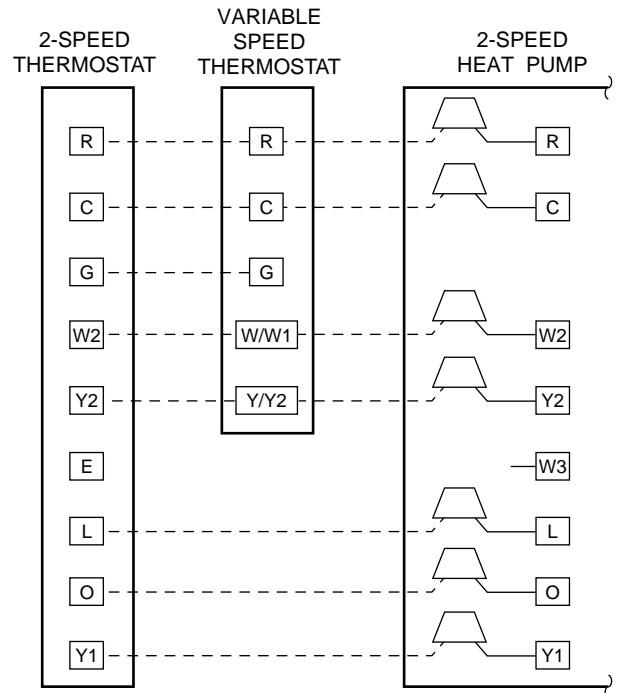

A94303

**Fig. 46—Wiring Schematic for 2-Speed Heat Pump Applications**

#### Step 7—Continuous Fan Mode

1. **Operating with continuous fan only**—
  - a. **Call for continuous fan**—The thermostat closes R-G circuit.
  - b. **Blower on**—The blower starts immediately.

**NOTE:** The blower starts at approximately 400-500 RPM. After 20 sec, the motor is turned off for 1/10 of a sec where a coast down calibration is done to evaluate resistance of the conditioned air duct system. The microprocessor then determines blower RPM required to provide proper airflow for heating mode.

**NOTE:** The continuous fan speed is the same as low-heat speed unless it is field adjusted to another desired airflow. See Continuous Fan Setup Switches section. There is also a chart on wiring diagram. (See Fig. 24.)

- c. **Electronic Air Cleaner**—The EAC-1 terminal is energized whenever blower operates, regardless of operating mode.
2. **Operating with continuous fan (R-G) and call for heat (R-W/W1) is received**—Same as heat pump mode except blower on delay is 10 sec less than heat mode. After call for

heat (R-W/W1) is terminated, the blower remains operating at low-heat speed for selected blower off delay before resuming continuous fan speed.

3. **Operating with continuous fan (R-G) and call for cooling (R-Y/Y2) is received**—See Cooling Mode section. After call for cooling (R-Y/Y2) is terminated, the blower remains operating at cooling speed for 90 sec before resuming continuous fan speed.

### Step 8—Component Test

All components are functionally operated except gas valve with component test feature.

This feature helps diagnose a system problem in case of a component failure.

**NOTE:** Setup switch SW-1 MUST be in OFF position or Fault Code 22 (setup error) will occur.

**NOTE:** NO thermostat signal may be present at control center, and all blower time delay off periods must be completed.

To initiate component test feature, proceed with the following:

1. Leave 115-v power to furnace turned on.
2. Remove main furnace door.
3. Remove blower access panel.
4. Move setup switch SW-6 to ON position.
5. Manually close blower access panel door switch. Use a piece of tape to hold switch closed.

### **⚠ WARNING**

Blower access panel door switch opens 115-v power to control center. No component operation can occur. Caution must be taken when manually closing this switch for service purposes. Failure to follow this warning could result in personal injury or death.

When items 1-5 have been completed, the following will occur:

1. The control center goes through a brief self-test. This self-test takes approximately 2 sec to complete. After door switch is closed, red (microprocessor) LED briefly comes on. Then green LED comes on for 1 sec, followed by 1 sec where both green and yellow LEDs are on. During this time, the microprocessor is checking itself.
2. Inducer motor operates for 20 sec at low speed, operates for 20 sec at high speed, then turns off.
3. Hot surface ignitor is energized for 15 sec, then de-energized.
4. Main blower motor operates for 20 sec at low speed, operates for 20 sec at high speed, then turns off.
5. After component operation test is completed, 1 or more fault codes (11, 22, 41, or 42) will flash. See service label on back of main furnace door for explanation of fault codes.

**NOTE:** To repeat component test, turn setup switch SW-6 to OFF and then back to ON.

After component test, perform the following:

1. Release blower panel access door switch and turn setup switch SW-6 to OFF position.
2. If applicable, replace blower access panel and check LED status by removing plug in blower access panel.
3. Reinstall main furnace door if all LEDs are off, indicating furnace is ready to operate when a signal from thermostat is received.

### Step 9—Bypass Humidifier Mode

When setup switch SW-3 BPH is in ON position, RPM calculated for low heat is multiplied by 1.15 for all furnace model sizes. This compensates for increased return-air temperature caused by bypassed air supply.

### Step 10—Dehumidification Mode

A dehumidification input is provided via a 1/4 in. male quick-connect terminal labeled DEHUM located next to the transformer secondary connections. When there is a dehumidify demand, the DEHUM input is activated, which means 24 vac signal is removed from the DEHUM input terminal. In other words, the DEHUM input logic is reversed. The DEHUM input is turned ON when no dehumidify demand exists and is turned OFF when demand exists. This logic reversal has come about from historical use of a standard humidistat to do dehumidification since the contacts open on high humidity, thus removing the 24-v signal to initiate dehumidification.

The DEHUM output on the thermidistat control or the humidistat output, is connected directly to the DEHUM terminal on the furnace control. In addition, the DE jumper located next to the DEHUM terminal must be removed to enable the DEHUM input (See Fig. 27 and 28). When a dehumidify demand exists, the furnace control reduces the blower airflow by 21 percent to 315 CFM per ton during continuous fan or cooling operation.

This blower speed reduction compensates for high humidity conditions during cooling operation on all furnace model sizes. Reference Thermidistat™ Control Installation, Start-Up, and Operating Instructions for further details.

### Step 11—Zone Mode

When setup switch SW-5 MZ is in ON position, blower motor control is the same as above except with the following exceptions:

1. While blower is operating in either low heat or continuous fan, the coast down calibration is performed once a minute to update blower RPM for zone damper position changes during a given cycle unless the blower pulse width to blower motor is greater than 60 percent. This prevents nuisance faults from occurring when a high continuous fan CFM has been selected.
2. While blower is operating in either high heat or cooling, blower pulse width to blower motor is frozen when blower RPM is within 10 percent of calculated blower RPM for 5 sec.

## START-UP PROCEDURES

### Step 1—General

1. Furnace must have a 115-v power supply properly connected and grounded.

**NOTE:** Proper polarity must be maintained for 115-v wiring. If polarity is incorrect, control center fault indicator light flashes rapidly and furnace does not operate.

2. Thermostat wire connections at terminals R, W/W1, G, and Y/Y2 must be made at 24-v terminal block on control center.
3. Natural gas service pressure must not exceed 0.5 psig (14-in. wc), but must be no less than 0.16 psig (4.5-in. wc).
4. Blower access panel must be in place to complete 24-v electrical circuit to furnace.

**Table 8—Air Conditioning (A/C) Airflow Setup Switch Position**

AIR CONDITIONER (TONS)	CFM AIRFLOW	A/C SETUP SWITCH POSITION			ALLOWABLE FURNACE MODEL SETUP					
		A/C-1	A/C-2	A/C-3	040-14	060-14	080-14	080-20	100-20	120-20
Default	1200 or 2000	OFF	OFF	OFF	3 Tons 1200 CFM	3 Tons 1200 CFM	3 Tons 1200 CFM	5 Tons 2000 CFM	5 Tons 2000 CFM	5 Tons 2000 CFM
1-1/2	600	ON	OFF	OFF	X	X	X	—	—	—
2	800	OFF	ON	OFF	X	X	X	X	X	X
2-1/2	1000	ON	ON	OFF	X	X	X	X	X	X
3	1200	OFF	OFF	ON	X	X	X	X	X	X
3-1/2	1400	ON	OFF	ON	X	X	X	X	X	X
4	1600	OFF	ON	ON	—	—	—	X	X	X
5	2000	ON	ON	ON	—	—	—	X	X	X

X—Indicates allowable selection.

**⚠ CAUTION**

These furnaces are equipped with a manual reset limit switch in burner box. This switch opens if an overheat condition (rollout) occurs in burner enclosure. Correct inadequate combustion-air supply or improper venting condition and reset switch. **DO NOT** jumper this switch.

Before operating furnace, check each manual reset switch for continuity. If necessary, press button to reset switch.

**Step 2—Select Setup Switch Positions**

**AIR CONDITIONING (A/C) SETUP SWITCHES**

The air conditioning setup switches are used to match furnace airflow to cooling unit used. This furnace will provide 400 CFM per selected air conditioning tonnage.

To set the desired cooling airflow:

1. Remove main furnace door and blower access panel.
2. Locate A/C setup switches on control center. (See Fig. 25.)
3. Determine air conditioning tonnage used.
4. Use Table 8 or wiring schematic to determine proper setup position of A/C switches. (See Fig. 24 and 47.)



A95198

**Fig. 47—Example of Setup Switch in OFF Position**

**NOTE:** Excessive airflow caused by improper A/C switch setup may cause condensate blow off in cooling mode.

5. Replace main furnace door and blower access panel.

**NOTE:** EAC-1 terminal is energized whenever blower operates. HUM terminal is only energized when gas valve is energized.

**CONTINUOUS FAN (CF) SETUP SWITCHES**

The CF setup switches are used to select desired airflow when thermostat is in continuous fan mode. This setup feature allows continuous fan airflow to be adjusted. To set desired continuous fan airflow:

1. Remove main furnace door and blower access panel.
2. Locate CF setup switches on control center. (See Fig. 25.)
3. Determine desired continuous fan airflow.
4. Use Table 9 or wiring schematic to determine proper setup position of CF switches. (See Fig. 24 and 48.)

**NOTE:** The CF switches are factory set to provide continuous fan airflow equal to low-heat mode.

5. Replace main furnace door and blower access panel.

**SETUP SWITCHES (SW)**

The control center has 8 setup switches that may be set to meet the application requirements. Position these setup switches for the appropriate requirement.

1. Remove main furnace door and blower access panel.
2. Locate setup switches on control center. (See Fig. 25.)
3. See Table 10 for setup switch description. (See Fig. 24 and 48.)
4. Replace main furnace door and blower access panel.

**NOTE:** If a bypass humidifier is used, setup switch SW-3 (BPH) should be in ON position. This prevents nuisance limit trips caused by the increased temperature in return air resulting from bypass.

**NOTE:** If modulating dampers are used, setup switch SW-5 (MZ) should be in ON position. This allows furnace control center to compensate for modulating dampers. The control re-calibrates for new system static conditions once every minute while operating in low-heat or continuous fan modes.

**Step 3—Prime Condensate Trap With Water**

**⚠ CAUTION**

Condensate trap must be PRIMED or proper draining may not occur. The condensate trap has 2 internal chambers which can ONLY be primed by pouring water into the inducer drain side of condensate trap.

1. Remove upper inducer housing drain connection cap. (See Fig. 48.)
2. Connect field-supplied 1/2-in. ID tube to upper inducer housing drain connection.
3. Insert field-supplied funnel into tube.
4. Pour 1 quart of water into funnel/tube. Water should run through inducer housing, overflow condensate trap, and flow into open field drain. (See Fig. 49.)
5. Remove funnel and tube from inducer housing and replace drain connection cap and clamp.

**Table 9—Continuous Fan (CF) Airflow Setup Switch Position**

CONTINUOUS FAN (CFM)	CF SETUP SWITCH POSITION			ALLOWABLE FURNACE MODEL SETUP					
	CF-1	CF-2	CF-3	040-14	060-14	080-14	080-20	100-20	120-20
Default	OFF	OFF	OFF	565*	515*	690*	690*	860*	1035*
600	ON	OFF	OFF	X	X	X	—	—	—
800	OFF	ON	OFF	X	X	X	X	X	X
1000	ON	ON	OFF	X	X	X	X	X	X
1200	OFF	OFF	ON	X	X	X	X	X	X
1400	ON	OFF	ON	X	X	X	X	X	X
1600	OFF	ON	ON	—	—	—	X	X	X
2000	ON	ON	ON	—	—	—	X	X	X

\* Add 15% additional CFM when Bypass Humidifier switch SW-3 on control board is used.  
X—Indicates allowable selection.

**Table 10—Setup Switch Description**

SETUP SWITCH NO.	NORMAL POSITION	DESCRIPTION OF USE
SW-1 (FLT)	OFF	Turn switch to ON for fault history display. No thermostat signal can be present for fault history display.
SW-2 (LOW)	OFF	Turn switch to ON to lock furnace in low-heat mode only or when using a 2-stage thermostat with R-W/W1 and R-W2 signals.
SW-3 (BPH)	OFF	Turn switch to ON when a bypass humidifier is used. This compensates for higher return-air temperature and provides 15 percent more airflow in low-heat mode only.
SW-4 (EMER HEAT)	OFF	Turn switch to ON to bypass microprocessor control. Furnace will operate at high heat only with main blower and inducer motor operating at maximum RPM. NO safeties are bypassed.
SW-5 (MZ)	OFF	Turn switch to ON when modulating dampers are used. In this mode, main blower speed is recalculated once every minute while furnace is in low-heat or continuous fan mode.
SW-6 (COMP TEST)	OFF	Turn switch to ON to initiate component test. Furnace will operate inducer motor for 20 sec at low speed, operate inducer motor for 20 sec at high speed, energize HSI for 15 sec, operate blower for 20 sec at low speed, and operate blower for 20 sec at high speed. SW-1 must be in OFF position. No thermostat signal can be present for component test to be initiated.
SW-7 and -8 (Blower Off Delay)	See Table 11	Adjust switches to provide desired heating mode blower off delay time, 90, 135, 180, or 225 sec.

**Table 11—Blower Off Delay Setup Switch Position**

DESIRED HEATING MODE BLOWER OFF DELAY (SEC)	SETUP SWITCH (SW-7 AND -8) POSITION	
	SW-7	SW-8
90	OFF	OFF
135	ON	OFF
180	OFF	ON
225	ON	ON

**Step 4—Purge Gas Lines**

If not previously done, purge the lines after all connections have been made and check for leaks.

**⚠ WARNING**

Never purge a gas line into a combustion chamber. Never use matches, candles, flame, or other sources of ignition for the purpose of checking leakage. Use a soap-and-water solution to check for leakage. Failure to follow this warning could result in fire, explosion, personal injury, or death.

**Step 5—Adjustments**

**SET GAS INPUT RATE**

Furnace gas input rate on rating plate is for installations at altitudes up to 2000 ft.

In the U.S.A., the input rating for altitudes above 2000 ft must be reduced by 2 percent for each 1000 ft above sea level.

In Canada, the input rating must be derated by 5 percent for altitudes of 2000 ft to 4500 ft above sea level.

Furnace input rate must be within ±2 percent of input on furnace rating plate.

1. Determine natural gas orifice size and manifold pressure for correct input.
  - a. Obtain yearly heat value average (at installed altitude) from local gas supplier.
  - b. Obtain yearly specific gravity average from local gas supplier.
  - c. Verify furnace model. Table 12 can only be used for model 58MVP Furnaces.
  - d. Find installation altitude in Table 12.

**NOTE:** For Canada altitudes of 2000 to 4500 ft, use U.S.A. altitudes of 2001 to 3000 ft in Table 12.

- e. Find closest natural gas heat value and specific gravity in Table 12.
- f. Follow heat value and specific gravity lines to point of intersection to find orifice size and low- and high-heat manifold pressure settings for proper operation.

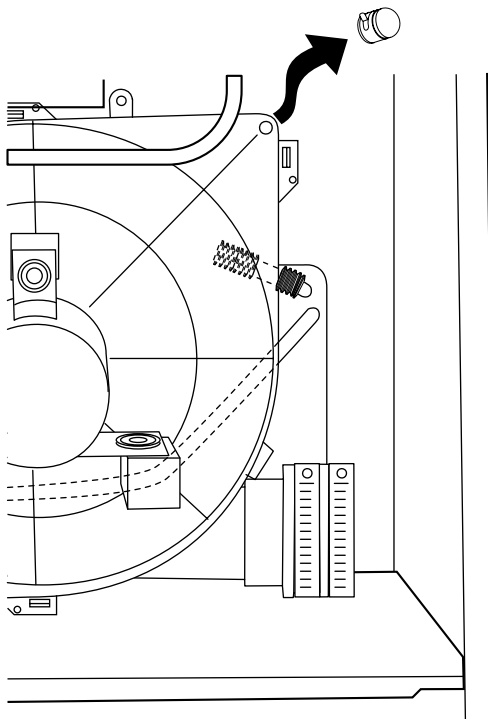

Fig. 48—Inducer Housing Drain Tube

A99118

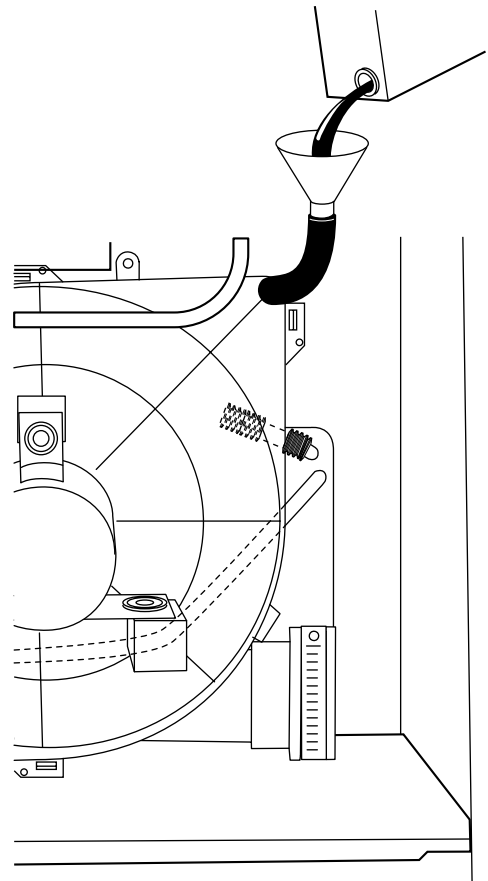

Fig. 49—Filling Condensate Trap

A99119

EXAMPLE: (0—2000 ft altitude)

Heating value = 1050 Btu/cu ft

Specific gravity = 0.62

Therefore: Orifice No. 45

Manifold pressure: 3.6-in. wc for high heat

1.5-in. wc for low heat

\* Furnace is shipped with No. 45 orifices. In this example, all main burner orifices are the correct size and do not need to be changed to obtain proper input rate.

g. Check and verify burner orifice size in furnace. NEVER ASSUME ORIFICE SIZE; ALWAYS CHECK AND VERIFY.

2. Adjust manifold pressure to obtain input rate.

a. Remove burner enclosure front.

**NOTE:** Manifold pressure MUST always be measured with the burner box cover REMOVED.

b. Remove caps that conceal adjustment screws for low- and high-heat gas valve regulators. (See Fig. 50.)

c. Move setup switch SW-2 on control center to ON position. (See Fig. 25.) This keeps furnace locked in low-heat operation.

d. Jumper R and W/W1 thermostat connections on control center to start furnace.

e. Turn low-heat adjusting screw (5/64 hex Allen wrench) counterclockwise (out) to decrease input rate or clockwise (in) to increase input rate.

**NOTE:** DO NOT set low-heat manifold pressure less than 1.3-in. wc or more than 1.7-in. wc for natural gas. If manifold pressure is outside this range, change main burner orifices.

### ⚠ CAUTION

DO NOT bottom out gas valve regulator adjusting screw. This can result in unregulated manifold pressure and result in excess overfire and heat exchanger failures.

**NOTE:** If orifice hole appears damaged or it is suspected to have been redrilled, check orifice hole with a numbered drill bit of correct size. Never redrill an orifice. A burr-free and squarely aligned orifice hole is essential for proper flame characteristics.

f. Move setup switch SW-2 to OFF position after completing low-heat adjustment.

g. Jumper R and W2 thermostat connections on control center. (See Fig. 25.) This keeps furnace locked in high-heat operation.

h. Turn high-heat adjusting screw (5/64 hex Allen wrench) counterclockwise (out) to decrease input rate or clockwise (in) to increase rate.

**NOTE:** DO NOT set high-heat manifold pressure less than 3.2-in. wc or more than 3.8-in. wc for natural gas. If manifold pressure is outside this range, change main burner orifices.

i. When correct input is obtained, replace caps that conceal gas valve regulator adjustment screws. Main burner flame should be clear blue, almost transparent. (See Fig. 51.)

j. Remove jumpers R to W/W1 and R to W2

3. Verify natural gas input rate by clocking gas meter.

**NOTE:** Be sure all pressure tubing, combustion-air and vent pipes, and burner enclosure front are in place when checking input by clocking gas meter.

a. Calculate high-altitude adjustment (if required).

**Table 12—Model 58MVP Orifice Size and Manifold Pressure for Correct Input  
(Tabulated Data Based on 20,000 Btuh High Heat/13,000 Btuh Low Heat per Burner  
Derated 2% for each 1000 ft Above Sea Level) \***

ALTITUDE RANGE (FT)		AVG GAS HEAT VALUE AT ALTITUDE (BTU/CU FT)	SPECIFIC GRAVITY OF NATURAL GAS									
			0.58		0.60		0.62		0.64		0.66	
			Orifice No.	Manifold Pressure High/Low	Orifice No.	Manifold Pressure High/Low	Orifice No.	Manifold Pressure High/Low	Orifice No.	Manifold Pressure High/Low	Orifice No.	Manifold Pressure High/Low
U.S.A. and Canada	0 to 2000	850	43	3.7/1.5	43	3.8/1.6	42	3.2/1.4	42	3.3/1.4	42	3.4/1.4
		875	43	3.5/1.5	43	3.6/1.5	43	3.7/1.6	43	3.8/1.6	42	3.2/1.4
		900	44	3.7/1.6	43	3.4/1.4	43	3.5/1.5	43	3.6/1.5	43	3.7/1.6
		925	44	3.5/1.5	44	3.7/1.6	44	3.8/1.6	43	3.4/1.4	43	3.5/1.5
		950	44	3.4/1.4	44	3.5/1.5	44	3.6/1.5	44	3.7/1.6	44	3.8/1.6
		975	44	3.2/1.3	44	3.3/1.4	44	3.4/1.4	44	3.5/1.5	44	3.6/1.5
		1000	<b>45</b>	<b>3.7/1.6</b>	<b>45</b>	<b>3.8/1.6</b>	44	3.2/1.4	44	3.4/1.4	44	3.5/1.5
		1025	<b>45</b>	<b>3.5/1.5</b>	<b>45</b>	<b>3.6/1.5</b>	<b>45</b>	<b>3.7/1.6</b>	44	3.2/1.3	44	3.3/1.4
		1050	<b>45</b>	<b>3.3/1.4</b>	<b>45</b>	<b>3.4/1.5</b>	<b>45</b>	<b>3.6/1.5</b>	<b>45</b>	<b>3.7/1.6</b>	<b>45</b>	<b>3.8/1.6</b>
		1075	<b>45</b>	<b>3.2/1.3</b>	<b>45</b>	<b>3.3/1.4</b>	<b>45</b>	<b>3.4/1.4</b>	<b>45</b>	<b>3.5/1.5</b>	<b>45</b>	<b>3.6/1.5</b>
		1100	47	3.6/1.5	47	3.7/1.6	<b>45</b>	<b>3.2/1.4</b>	<b>45</b>	<b>3.4/1.4</b>	<b>45</b>	<b>3.5/1.5</b>
U.S.A. and Canada	U.S.A. Altitudes 2001 to 3000 or Canada Altitudes 2000 to 4500	775	43	3.8/1.6	42	3.2/1.4	42	3.3/1.4	42	3.4/1.4	42	3.5/1.5
		800	43	3.5/1.5	43	3.7/1.5	43	3.8/1.6	42	3.2/1.4	42	3.3/1.4
		825	44	3.8/1.6	43	3.4/1.5	43	3.6/1.5	43	3.7/1.5	43	3.8/1.6
		850	44	3.6/1.5	44	3.7/1.6	44	3.8/1.6	43	3.5/1.5	43	3.6/1.5
		875	44	3.4/1.4	44	3.5/1.5	44	3.6/1.5	44	3.7/1.6	43	3.4/1.4
		900	44	3.2/1.4	44	3.3/1.4	44	3.4/1.4	44	3.5/1.5	44	3.6/1.5
		925	<b>45</b>	<b>3.7/1.5</b>	<b>45</b>	<b>3.8/1.6</b>	44	3.2/1.4	44	3.3/1.4	44	3.4/1.5
		950	<b>45</b>	<b>3.5/1.5</b>	<b>45</b>	<b>3.6/1.5</b>	<b>45</b>	<b>3.7/1.6</b>	<b>45</b>	<b>3.8/1.6</b>	44	3.3/1.4
		975	<b>45</b>	<b>3.3/1.4</b>	<b>45</b>	<b>3.4/1.4</b>	<b>45</b>	<b>3.5/1.5</b>	<b>45</b>	<b>3.6/1.5</b>	<b>45</b>	<b>3.8/1.6</b>
		1000	47	3.7/1.6	<b>45</b>	<b>3.2/1.4</b>	<b>45</b>	<b>3.4/1.4</b>	<b>45</b>	<b>3.5/1.5</b>	<b>45</b>	<b>3.6/1.5</b>
		1025	47	3.6/1.5	47	3.7/1.6	<b>45</b>	<b>3.2/1.3</b>	<b>45</b>	<b>3.3/1.4</b>	<b>45</b>	<b>3.4/1.4</b>
U.S.A. Only	3001 to 4000	750	43	3.7/1.6	43	3.8/1.6	42	3.3/1.4	42	3.4/1.4	42	3.5/1.5
		775	43	3.5/1.5	43	3.6/1.5	43	3.7/1.6	43	3.8/1.6	42	3.2/1.4
		800	44	3.7/1.6	43	3.4/1.4	43	3.5/1.5	43	3.6/1.5	43	3.7/1.6
		825	44	3.5/1.5	44	3.6/1.5	44	3.8/1.6	43	3.4/1.4	43	3.5/1.5
		850	44	3.3/1.4	44	3.4/1.4	44	3.5/1.5	44	3.7/1.5	44	3.8/1.6
		875	<b>45</b>	<b>3.8/1.6</b>	44	3.2/1.4	44	3.3/1.4	44	3.5/1.5	44	3.6/1.5
		900	<b>45</b>	<b>3.6/1.5</b>	<b>45</b>	<b>3.7/1.6</b>	<b>45</b>	<b>3.8/1.6</b>	44	3.3/1.4	44	3.4/1.4
		925	<b>45</b>	<b>3.4/1.4</b>	<b>45</b>	<b>3.5/1.5</b>	<b>45</b>	<b>3.6/1.5</b>	<b>45</b>	<b>3.7/1.6</b>	44	3.2/1.3
		950	<b>45</b>	<b>3.2/1.4</b>	<b>45</b>	<b>3.3/1.4</b>	<b>45</b>	<b>3.4/1.5</b>	<b>45</b>	<b>3.5/1.5</b>	<b>45</b>	<b>3.7/1.5</b>
		975	47	3.6/1.5	<b>45</b>	<b>3.2/1.3</b>	<b>45</b>	<b>3.3/1.4</b>	<b>45</b>	<b>3.4/1.4</b>	<b>45</b>	<b>3.5/1.5</b>
		1000	47	3.5/1.5	47	3.6/1.5	47	3.7/1.6	<b>45</b>	<b>3.2/1.4</b>	<b>45</b>	<b>3.3/1.4</b>

\* Orifice numbers shown in **BOLD** are factory installed.

**Table 12—Model 58MVP Orifice Size and Manifold Pressure for Correct Input (Continued)**  
 (Tabulated Data Based on 20,000 Btuh High Heat/13,000 Btuh Low Heat per Burner  
 Derated 2% for each 1000 ft Above Sea Level) \*

ALTITUDE RANGE (FT)		AVG GAS HEAT VALUE AT ALTITUDE (BTU/CU FT)	SPECIFIC GRAVITY OF NATURAL GAS									
			0.58		0.60		0.62		0.64		0.66	
			Orifice No.	Manifold Pressure High/Low	Orifice No.	Manifold Pressure High/Low	Orifice No.	Manifold Pressure High/Low	Orifice No.	Manifold Pressure High/Low	Orifice No.	Manifold Pressure High/Low
U.S.A. Only	4001	725	43	3.7/1.5	43	3.8/1.6	42	3.2/1.4	42	3.3/1.4	42	3.4/1.4
		750	43	3.4/1.4	43	3.5/1.5	43	3.7/1.5	43	3.8/1.6	42	3.2/1.4
		775	44	3.7/1.6	44	3.8/1.6	43	3.4/1.4	43	3.5/1.5	43	3.7/1.5
		800	44	3.5/1.5	44	3.6/1.5	44	3.7/1.6	44	3.8/1.6	43	3.4/1.4
		825	44	3.2/1.4	44	3.4/1.4	44	3.5/1.5	44	3.6/1.5	44	3.7/1.6
	5000	850	<b>45</b>	<b>3.7/1.6</b>	<b>45</b>	<b>3.8/1.6</b>	44	3.3/1.4	44	3.4/1.4	44	3.5/1.5
		875	<b>45</b>	<b>3.5/1.5</b>	<b>45</b>	<b>3.6/1.5</b>	<b>45</b>	<b>3.7/1.6</b>	44	3.2/1.3	44	3.3/1.4
		900	<b>45</b>	<b>3.3/1.4</b>	<b>45</b>	<b>3.4/1.4</b>	<b>45</b>	<b>3.5/1.5</b>	<b>45</b>	<b>3.6/1.5</b>	<b>45</b>	<b>3.8/1.6</b>
		925	47	3.7/1.6	<b>45</b>	<b>3.2/1.4</b>	<b>45</b>	<b>3.3/1.4</b>	<b>45</b>	<b>3.4/1.5</b>	<b>45</b>	<b>3.6/1.5</b>
		950	47	3.5/1.5	47	3.6/1.5	<b>45</b>	<b>3.2/1.3</b>	<b>45</b>	<b>3.3/1.4</b>	<b>45</b>	<b>3.4/1.4</b>
U.S.A. Only	5001	700	43	3.6/1.5	43	3.7/1.6	42	3.2/1.3	42	3.3/1.4	42	3.4/1.4
		725	43	3.4/1.4	43	3.5/1.5	43	3.6/1.5	43	3.7/1.6	43	3.8/1.6
		750	44	3.6/1.5	44	3.7/1.6	43	3.4/1.4	43	3.5/1.5	43	3.6/1.5
		775	44	3.4/1.4	44	3.5/1.5	44	3.6/1.5	44	3.7/1.6	43	3.4/1.4
		800	44	3.2/1.3	44	3.3/1.4	44	3.4/1.4	44	3.5/1.5	44	3.6/1.5
		825	<b>45</b>	<b>3.6/1.5</b>	<b>45</b>	<b>3.7/1.6</b>	44	3.2/1.4	44	3.3/1.4	44	3.4/1.4
		850	<b>45</b>	<b>3.4/1.4</b>	<b>45</b>	<b>3.5/1.5</b>	<b>45</b>	<b>3.6/1.5</b>	<b>45</b>	<b>3.8/1.6</b>	44	3.2/1.4
	6000	875	<b>45</b>	<b>3.2/1.4</b>	<b>45</b>	<b>3.3/1.4</b>	<b>45</b>	<b>3.4/1.5</b>	<b>45</b>	<b>3.6/1.5</b>	<b>45</b>	<b>3.7/1.5</b>
		900	47	3.6/1.5	47	3.7/1.6	<b>45</b>	<b>3.3/1.4</b>	<b>45</b>	<b>3.4/1.4</b>	<b>45</b>	<b>3.5/1.5</b>
		925	47	3.4/1.4	47	3.5/1.5	47	3.7/1.5	<b>45</b>	<b>3.2/1.3</b>	<b>45</b>	<b>3.3/1.4</b>
		950	48	3.7/1.6	48	3.8/1.6	47	3.5/1.5	47	3.6/1.5	47	3.7/1.6
		975	48	3.5/1.5	48	3.6/1.5	48	3.8/1.6	47	3.4/1.4	47	3.5/1.5
		990	48	3.3/1.4	48	3.5/1.5	48	3.6/1.5	48	3.7/1.6	48	3.8/1.6
		1000	48	3.3/1.4	48	3.5/1.5	48	3.6/1.5	48	3.7/1.6	48	3.8/1.6
U.S.A. Only	6001 to 7000	650	42	3.2/1.3	42	3.3/1.4	42	3.4/1.4	42	3.5/1.5	42	3.6/1.5
		675	43	3.6/1.5	43	3.7/1.6	43	3.8/1.6	42	3.2/1.4	42	3.3/1.4
		700	44	3.8/1.6	43	3.4/1.5	43	3.6/1.5	43	3.7/1.6	43	3.8/1.6
		725	44	3.6/1.5	44	3.7/1.6	44	3.8/1.6	43	3.4/1.4	43	3.5/1.5
		750	44	3.3/1.4	44	3.4/1.5	44	3.6/1.5	44	3.7/1.6	44	3.8/1.6
		775	<b>45</b>	<b>3.8/1.6</b>	44	3.2/1.4	44	3.3/1.4	44	3.4/1.5	44	3.5/1.5
		800	<b>45</b>	<b>3.5/1.5</b>	<b>45</b>	<b>3.7/1.5</b>	<b>45</b>	<b>3.8/1.6</b>	44	3.2/1.4	44	3.3/1.4
		825	<b>45</b>	<b>3.3/1.4</b>	<b>45</b>	<b>3.4/1.5</b>	<b>45</b>	<b>3.6/1.5</b>	<b>45</b>	<b>3.7/1.6</b>	<b>45</b>	<b>3.8/1.6</b>
		850	47	3.7/1.6	<b>45</b>	<b>3.2/1.4</b>	<b>45</b>	<b>3.4/1.4</b>	<b>45</b>	<b>3.5/1.5</b>	<b>45</b>	<b>3.6/1.5</b>
		875	47	3.5/1.5	47	3.6/1.5	<b>45</b>	<b>3.2/1.3</b>	<b>45</b>	<b>3.3/1.4</b>	<b>45</b>	<b>3.4/1.4</b>

\* Orifice numbers in **BOLD** are factory installed.

**Table 12—Model 58MVP Orifice Size and Manifold Pressure for Correct Input (Continued)**  
 (Tabulated Data Based on 20,000 Btuh High Heat/13,000 Btuh Low Heat per Burner  
 Derated 2% for each 1000 ft Above Sea Level) \*

ALTITUDE RANGE (FT)		AVG GAS HEAT VALUE AT ALTITUDE (BTU/CU FT)	SPECIFIC GRAVITY OF NATURAL GAS									
			0.58		0.60		0.62		0.64		0.66	
			Orifice No.	Manifold Pressure High/Low	Orifice No.	Manifold Pressure High/Low	Orifice No.	Manifold Pressure High/Low	Orifice No.	Manifold Pressure High/Low	Orifice No.	Manifold Pressure High/Low
U.S.A. Only	7001 to 8000	625	43	3.8/1.6	42	3.3/1.4	42	3.4/1.4	42	3.5/1.5	42	3.6/1.5
		650	43	3.5/1.5	43	3.7/1.6	43	3.8/1.6	42	3.2/1.4	42	3.3/1.4
		675	44	3.8/1.6	43	3.4/1.4	43	3.5/1.5	43	3.6/1.5	43	3.7/1.6
		700	44	3.5/1.5	44	3.6/1.5	44	3.8/1.6	43	3.4/1.4	43	3.5/1.5
		725	44	3.3/1.4	44	3.4/1.4	44	3.5/1.5	44	3.6/1.5	44	3.7/1.6
		750	<b>45</b>	<b>3.7/1.6</b>	<b>45</b>	<b>3.8/1.6</b>	44	3.3/1.4	44	3.4/1.4	44	3.5/1.5
		775	<b>45</b>	<b>3.5/1.5</b>	<b>45</b>	<b>3.6/1.5</b>	<b>45</b>	<b>3.7/1.6</b>	<b>45</b>	<b>3.8/1.6</b>	44	3.3/1.4
		800	<b>45</b>	<b>3.3/1.4</b>	<b>45</b>	<b>3.4/1.4</b>	<b>45</b>	<b>3.5/1.5</b>	<b>45</b>	<b>3.6/1.5</b>	<b>45</b>	<b>3.7/1.6</b>
		825	47	3.6/1.5	<b>45</b>	<b>3.2/1.3</b>	<b>45</b>	<b>3.3/1.4</b>	<b>45</b>	<b>3.4/1.4</b>	<b>45</b>	<b>3.5/1.5</b>
		850	47	3.4/1.4	47	3.5/1.5	47	3.7/1.5	<b>45</b>	<b>3.2/1.3</b>	<b>45</b>	<b>3.3/1.4</b>
U.S.A. Only	8001 to 9000	600	43	3.8/1.6	42	3.3/1.4	42	3.4/1.4	42	3.5/1.5	42	3.6/1.5
		625	43	3.5/1.5	43	3.6/1.5	43	3.8/1.6	42	3.2/1.4	42	3.3/1.4
		650	44	3.7/1.6	43	3.4/1.4	43	3.5/1.5	43	3.6/1.5	43	3.7/1.6
		675	44	3.5/1.5	44	3.6/1.5	44	3.7/1.6	44	3.8/1.6	43	3.4/1.5
		700	44	3.2/1.4	44	3.3/1.4	44	3.4/1.5	44	3.6/1.5	44	3.7/1.6
		725	<b>45</b>	<b>3.6/1.5</b>	<b>45</b>	<b>3.8/1.6</b>	44	3.2/1.4	44	3.3/1.4	44	3.4/1.4
		750	<b>45</b>	<b>3.4/1.4</b>	<b>45</b>	<b>3.5/1.5</b>	<b>45</b>	<b>3.6/1.5</b>	<b>45</b>	<b>3.8/1.6</b>	44	3.2/1.4
		775	<b>45</b>	<b>3.2/1.3</b>	<b>45</b>	<b>3.3/1.4</b>	<b>45</b>	<b>3.4/1.4</b>	<b>45</b>	<b>3.5/1.5</b>	<b>45</b>	<b>3.6/1.5</b>
		800	47	3.6/1.5	47	3.7/1.6	<b>45</b>	<b>3.2/1.3</b>	<b>45</b>	<b>3.3/1.4</b>	<b>45</b>	<b>3.4/1.4</b>
		U.S.A. Only	9001 to 10,000	575	43	3.8/1.6	42	3.2/1.4	42	3.3/1.4	42	3.5/1.5
600	43			3.5/1.5	43	3.6/1.5	43	3.7/1.6	42	3.2/1.3	42	3.3/1.4
625	44			3.7/1.6	44	3.8/1.6	43	3.5/1.5	43	3.6/1.5	43	3.7/1.6
650	44			3.4/1.4	44	3.5/1.5	44	3.7/1.5	44	3.8/1.6	43	3.4/1.4
675	<b>45</b>			<b>3.8/1.6</b>	44	3.3/1.4	44	3.4/1.4	44	3.5/1.5	44	3.6/1.5
700	<b>45</b>			<b>3.6/1.5</b>	<b>45</b>	<b>3.7/1.6</b>	<b>45</b>	<b>3.8/1.6</b>	44	3.3/1.4	44	3.4/1.4
725	<b>45</b>			<b>3.3/1.4</b>	<b>45</b>	<b>3.4/1.5</b>	<b>45</b>	<b>3.6/1.5</b>	<b>45</b>	<b>3.7/1.6</b>	<b>45</b>	<b>3.8/1.6</b>
750	47			3.7/1.6	<b>45</b>	<b>3.2/1.4</b>	<b>45</b>	<b>3.3/1.4</b>	<b>45</b>	<b>3.4/1.5</b>	<b>45</b>	<b>3.5/1.5</b>
775	47			3.5/1.5	47	3.6/1.5	47	3.7/1.6	<b>45</b>	<b>3.2/1.4</b>	<b>45</b>	<b>3.3/1.4</b>

\* Orifice numbers shown in **BOLD** are factory installed.

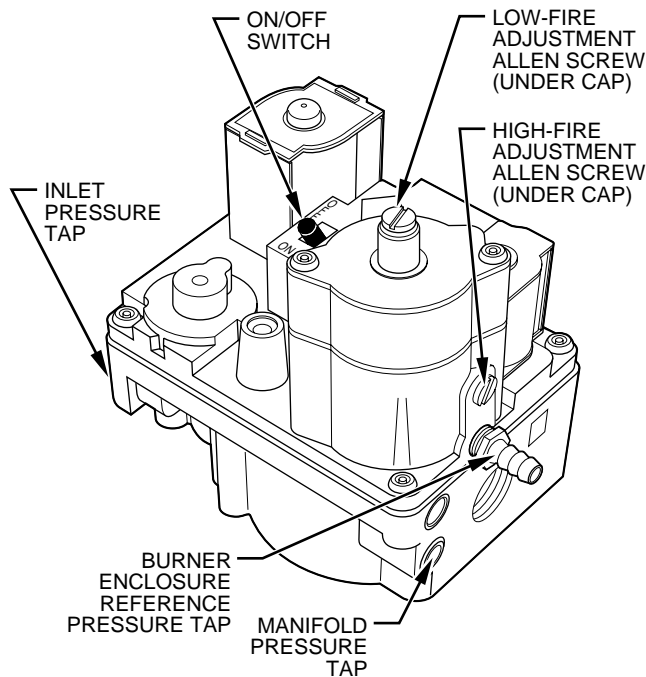

**Fig. 50—Redundant Automatic Gas Valve**

A97386

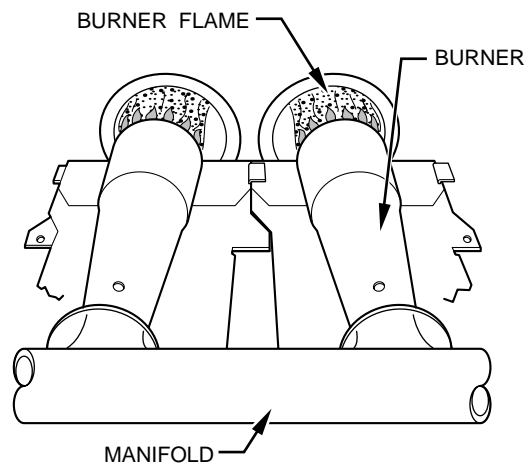

**Fig. 51—Burner Flame**

A89020

**Table 13—Altitude Derate Multiplier for U.S.A.**

ALTITUDE (FT)	% OF DERATE	DERATE MULTIPLIER FACTOR FOR U.S.A.*
0—2000	0	1.00
2001—3000	4—6	0.95
3001—4000	6—8	0.93
4001—5000	8—10	0.91
5001—6000	10—12	0.89
6001—7000	12—14	0.87
7001—8000	14—16	0.85
8001—9000	16—18	0.83
9001—10,000	18—20	0.81

\* Derate multiplier factor is based on midpoint altitude for altitude range.

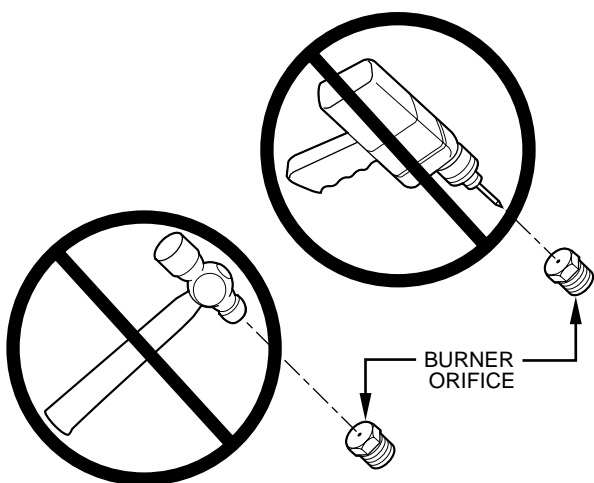

A93059

**CAUTION**

DO NOT redrill orifices. Improper drilling (burrs, out-of-round holes, etc.) can cause excessive burner noise and misdirection of burner flames. This can result in flame impingement of burners and heat exchangers, causing failures.

**UNITED STATES**

At altitudes above 2000 ft, this furnace has been approved for a 2 percent derate for each 1000 ft above sea level. See Table 13 for derate multiplier factor and example.

**EXAMPLE: 100,000 BTUH INPUT FURNACE INSTALLED AT 4300 FT.**

Furnace Input Rate at Sea Level	X	Derate Multiplier Factor	=	Furnace Input Rate at Installation Altitude
100,000	X	0.91	=	91,000

**CANADA**

At installation altitudes from 2000 to 4500 ft, this furnace must be derated 5 percent by an authorized Gas Conversion Station or Dealer. To determine correct input rate for altitude, see example above and use 0.95 as derate multiplier factor.

b. Reinstall burner box cover.

**NOTE:** Clocking gas input rate **MUST** always be performed with the burner box cover **INSTALLED**.

c. Check that gas valve adjustment caps are in place for proper input to be clocked.

d. Obtain yearly heat value average for local gas supply.

**NOTE:** Be sure heating value of gas used for calculations is correct for your altitude. Consult local gas utility for altitude adjustment of gas heating value.

e. Check and verify orifice size in furnace. **NEVER ASSUME THE ORIFICE SIZE. ALWAYS CHECK AND VERIFY.**

f. Turn off all other gas appliances and pilots.

g. Move setup switch SW-2 to ON position. (See Fig. 25.) This keeps furnace locked in low-heat operation.

- h. Jumper R to W/W1.
- i. Let furnace run for 3 minutes in low-heat operation.
- j. Measure time (in sec) for gas meter to complete 1 revolution. Note reading.
- k. Refer to Table 14 for cubic ft of gas per hr.
- l. Multiply gas rate cu ft/hr by heating value (Btu/cu ft).
- m. Move setup switch SW-2 to OFF position and jumper R and W2 thermostat connections. (See Fig. 25.) This keeps furnace locked in high-heat operation. Repeat items h through k for high-heat operation.

EXAMPLE: (High-heat operation at 0—2000 ft altitude)  
 Furnace input from rating plate is 100,000 Btuh  
 Btu heating input = Btu/cu ft X cu ft/hr  
 Heating value of gas = 975 Btu/cu ft  
 Time for 1 revolution of 2-cu ft dial = 70 sec  
 Gas rate = 103 cu ft/hr (from Table 14)  
 Btu heating input = 103 X 975 = 100,425 Btuh In this example, the orifice size and manifold pressure adjustment is within ±2 percent of the furnace input rate.

**NOTE:** Measured gas inputs (high heat and low heat) must be within ±2 percent of that stated on furnace rating plate when installed at sea level or derated per that stated above when installed at higher altitudes.

- n. Remove jumper across R, W/W1, and W2 thermostat connections to terminate call for heat.

## SET TEMPERATURE RISE

### ⚠ CAUTION

Temperature rise must be within limits specified on unit rating plate. Recommended operation is at midpoint of rise or above. Failure to follow this caution may result in condensing or overheating the heat exchangers.

Furnace must operate within range of temperature rise specified on the unit rating plate. Determine air temperature rise as follows:

1. Place thermometers in return and supply ducts as near furnace as possible. Be sure thermometers do not see heat exchanger so that radiant heat does not affect readings. This practice is particularly important with straight-run ducts.
2. When thermometer readings stabilize, subtract return-air temperature from supply-air temperature to determine air temperature rise.

**NOTE:** Temperature rise can be determined for low-fire operation by placing setup switch SW-2 on control center in ON position. For high-heat operation, place setup switch SW-2 in OFF position and jumper R-W2 on control center. DO NOT forget to return setup switch to OFF position and remove R-W2 jumper upon completion of testing. (See Fig. 25 for switch and terminal location.)

3. This furnace is capable of automatically providing proper airflow to maintain the temperature rise within the range specified on unit rating plate. If temperature rise is outside this range, proceed as follows:
  - a. Check gas input for low- and high-heat operation.
  - b. Check derate for altitude if applicable.
  - c. Check all return and supply ducts for excessive restrictions causing static pressure greater than 0.5-in. wc.
  - d. Ensure bypass humidifier switch (BPH) setup switch SW-3 on control center is in ON position when a bypass humidifier is used. (See Fig. 25 for switch location.)
  - e. Check Troubleshooting Guide for Variable-Speed 2-Stage Electronic Condensing Furnaces.

**Table 14—Gas Rate Cu Ft/Hr**

SECONDS FOR 1 REVOLUTION	SIZE OF TEST DIAL			SECONDS FOR 1 REVOLUTION	SIZE OF TEST DIAL		
	1 cu ft	2 cu ft	5 cu ft		1 cu ft	2 cu ft	5 cu ft
10	360	720	1800	50	72	144	360
11	327	655	1636	51	71	141	355
12	300	600	1500	52	69	138	346
13	277	555	1385	53	68	136	340
14	257	514	1286	54	67	133	333
15	240	480	1200	55	65	131	327
16	225	450	1125	56	64	129	321
17	212	424	1059	57	63	126	316
18	200	400	1000	58	62	124	310
19	189	379	947	59	61	122	305
20	180	360	900	60	60	120	300
21	171	343	857	62	58	116	290
22	164	327	818	64	56	112	281
23	157	313	783	66	54	109	273
24	150	300	750	68	53	106	265
25	144	288	720	70	51	103	257
26	138	277	692	72	50	100	250
27	133	267	667	74	48	97	243
28	129	257	643	76	47	95	237
29	124	248	621	78	46	92	231
30	120	240	600	80	45	90	225
31	116	232	581	82	44	88	220
32	113	225	563	84	43	86	214
33	109	218	545	86	42	84	209
34	106	212	529	88	41	82	205
35	103	206	514	90	40	80	200
36	100	200	500	92	39	78	196
37	97	195	486	94	38	76	192
38	95	189	474	96	38	75	188
39	92	185	462	98	37	74	184
40	90	180	450	100	36	72	180
41	88	176	439	102	35	71	178
42	86	172	429	104	35	69	173
43	84	167	419	106	34	68	170
44	82	164	409	108	33	67	167
45	80	160	400	110	33	65	164
46	78	157	391	112	32	64	161
47	76	153	383	116	31	62	155
48	75	150	375	120	30	60	150
49	73	147	367				

## SET THERMOSTAT HEAT ANTICIPATOR

The thermostat heat anticipator must be set to match the amp draw of components in the R-W/W1 circuit. Accurate amp draw measurements can be obtained at the thermostat subbase terminals R and W.

Fig. 52 illustrates an easy method of obtaining thermostat amp draw measurements. The amp reading should be taken after blower motor has started and furnace is operating in low heat.

1. To operate furnace in low heat, turn setup switch SW-2 to ON position (See Fig. 25) and connect ammeter leads across thermostat subbase R-W.
2. See thermostat manufacturer's instructions for adjusting the heat anticipator and for varying heating cycle length.

**NOTE:** When using an electronic thermostat, set cycle rate for 3 cycles per hr.

3. Return setup switch SW-2 to OFF position and replace thermostat on subbase.

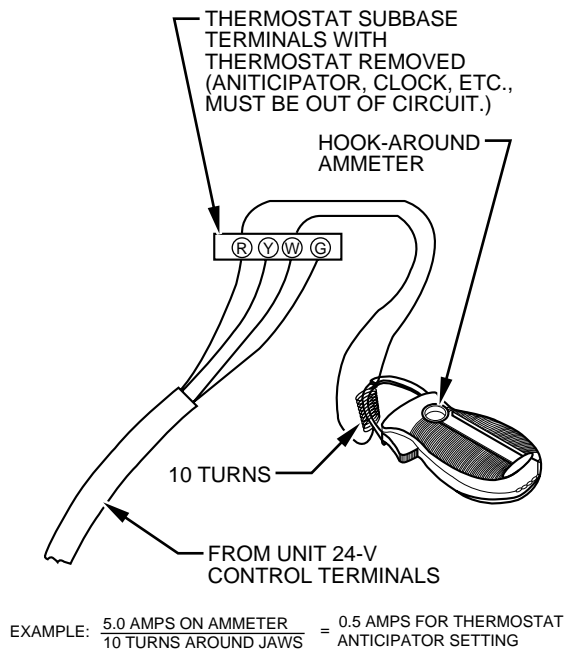

**Fig. 52—Amp Draw Check with Ammeter**

A96316

## CHECK SAFETY CONTROLS

### Step 1—Check Primary Limit Control

This control shuts off the combustion control system and energizes the air-circulating blower motor if furnace overheats.

1. The recommended method of checking this limit control is to gradually block off return air after furnace has been operating for a period of at least 5 minutes.
2. As soon as limit control has shut off burners, a 33 fault code will appear on control center.
3. The return-air opening should be unblocked to permit normal air circulation.

By using this method to check the limit control, it can be established that the limit is functioning properly and the furnace will operate safely if there is a restricted return-air supply or motor failure. If the limit control does not function during this test, the cause must be determined and corrected.

### Step 2—Check Pressure Switches

This control proves operation of the draft inducer. Check switch operation as follows:

1. Turn off 115-v power to furnace.
2. Remove control access door and disconnect inducer motor 12-pin wire harness at inducer motor.
3. Turn on 115-v power to furnace.
4. Set thermostat to call for heat. When pressure switches are functioning properly, fault code 42 will flash on control center approximately 10 sec after thermostat switch is closed. If either a fault code 31 or 32 is flashed when ICM inducer motor is disconnected, the furnace will shut itself down immediately. Determine the reason pressure switches did not function properly and correct the condition.
5. Turn off 115-v power to furnace.
6. Reconnect inducer motor wire harness. Reinstall furnace access door.
7. Turn on 115-v power to furnace.
8. Reset thermostat to desired temperature.

### CHECKLIST

1. Put away tools and instruments. Clean up debris.
2. Verify manual reset switch has continuity.
3. Verify that blower and control access doors are properly installed.
4. Cycle test furnace with room thermostat.
5. Check operation of accessories per manufacturer's instructions.
6. Review User's Manual with owner.
7. Leave literature packet near furnace.

## CHECKLIST—INSTALLATION

### LOAD CALCULATION

\_\_\_\_\_ Heating Load (Btuh)  
\_\_\_\_\_ Cooling Load (Btuh)  
\_\_\_\_\_ Furnace Model Selection

### COMBUSTION AND VENT PIPING

#### Termination Location

\_\_\_\_\_ Roof or Sidewall  
\_\_\_\_\_ Termination Kit — 2 Pipe or Concentric  
\_\_\_\_\_ Combustion-Air Pipe Length  
\_\_\_\_\_ Combustion-Air Pipe Elbow Quantity  
\_\_\_\_\_ Vent Pipe Length  
\_\_\_\_\_ Vent Pipe Elbow Quantity  
\_\_\_\_\_ Pipe Diameter Determined from Sizing Table  
\_\_\_\_\_ Pipe Sloped To Furnace

#### Pipe Insulation

\_\_\_\_\_ Over Ceilings  
\_\_\_\_\_ Low-Ambient Exposed Pipes

### Condensate Drain

\_\_\_\_\_ Unit Level or Pitched Forward  
\_\_\_\_\_ Internal Tubing Connections Free of Kinks and Traps  
\_\_\_\_\_ External Drain Connection Leak Tight and Sloped  
\_\_\_\_\_ Condensate Trap Primed before Start-Up  
\_\_\_\_\_ Heat Tape Installed if Required

### CHECKLIST—START-UP

\_\_\_\_\_ Gas Input Rate  
(Set Within 2 percent of Rating Plate)  
\_\_\_\_\_ Temperature Rise Adjusted  
\_\_\_\_\_ Thermostat Anticipator  
\_\_\_\_\_ Anticipator Setting Adjusted or  
\_\_\_\_\_ Cycle Rate (3 Cycles per Hr) Selected

### Safety Controls Check Operation

\_\_\_\_\_ Primary Limit  
\_\_\_\_\_ Pressure Switches

# SERVICE TRAINING

**Packaged Service Training** programs are an excellent way to increase your knowledge of the equipment discussed in this manual, including:

- Unit Familiarization
- Maintenance
- Installation Overview
- Operating Sequence

A large selection of product, theory, and skills programs is available, using popular video-based formats and materials. All include video and/or slides, plus companion book.

**Classroom Service Training** plus "hands-on" the products in our labs can mean increased confidence that really pays dividends in faster troubleshooting, fewer callbacks. Course descriptions and schedules are in our catalog.

**CALL FOR FREE CATALOG 1-800-962-9212**

Packaged Service Training

Classroom Service Training

A94328

---

**Manufacturer reserves the right to discontinue, or change at any time, specifications or designs without notice and without incurring obligations.**