

## Product Data



**Fig. 1 — Sizes 09 to 24**



**Fig. 2 — Heat Pump Remote Controller**



**Fig. 3 — Cooling Only Remoter Controller**

**NOTE:** Images are for illustration purposes **only**. Actual models may differ slightly.

### TABLE OF CONTENTS

INDUSTRY LEADING FEATURES / BENEFITS.....	1
MODEL NUMBER NOMENCLATURE .....	3
STANDARD FEATURES AND ACCESSORIES .....	4
DIMENSIONS .....	5
CLEARANCES.....	8
SPECIFICATIONS - COOLING ONLY .....	9
SPECIFICATIONS - HEAT PUMP .....	9
APPLICATION DATA .....	10
WIRING .....	11
AIR FLOW DATA .....	12
AIR THROW DATA .....	12
MOISTURE REMOVAL.....	12
SOUND PRESSURE .....	12
FAN AND MOTOR SPECIFICATIONS.....	13
WIRING DIAGRAMS.....	14
GUIDE SPECIFICATIONS.....	16

### INDUSTRY LEADING FEATURES / BENEFITS

#### A PERFECT BALANCE BETWEEN BUDGET LIMITS, ENERGY SAVINGS AND COMFORT

The **DLFEHA** series ductless systems are a matched combination of an outdoor condensing unit and an indoor fan coil unit connected only by refrigerant tubing and wires.

The fan coil is mounted on the wall, near the ceiling. This selection of fan coils permits creative solutions to design problems such as:

- Add-ons to current space (an office or family room addition)
- Special space requirements
- When changes in the load cannot be handled by the existing system
- When adding air conditioning to spaces that are heated by hydronic or electric heat and have no ductwork
- Historical renovations or any application where preserving the look of the original structure is essential.

The ideal compliment to your ducted system when it is impractical or prohibitively expensive to use ductwork. These compact indoor fan coil units take up very little space in the room and do not obstruct windows. The fan coils are attractively styled to blend with most room decors. Advanced system components incorporate innovative technology to provide reliable cooling performance at low sound levels.

## **LOW SOUND LEVELS**

When noise is a concern, the ductless systems are the answer. The indoor units are whisper quiet. There are no compressors indoors, either in the conditioned space or directly over it, and there is none of the noise usually generated by air being forced through ductwork.

## **SECURE OPERATION**

If security is an issue, outdoor and indoor units are connected only by refrigerant piping and wiring to prevent intruders from crawling through the ductwork. In addition, since outdoor units can be installed close to an outside wall, coils are protected from vandals and severe weather.

## **FAST INSTALLATION**

This compact ductless system is simple to install. A mounting bracket and duct work is needed for the indoor units, and only wire and piping need run between the indoor and outdoor units. These units are fast and easy to install ensuring minimal disruption to customers in the home or workplace. This makes the air handler systems the equipment of choice, especially in retrofit situations.

## **SIMPLE SERVICING AND MAINTENANCE**

Removing the top panel on outdoor units provides immediate access to the control compartment, providing a service technician access to check unit operation. In addition, the draw-thru design of the outdoor section means that dirt accumulates on the outside surface of the coil. Coils can be cleaned quickly from the inside using a pressure hose and detergent.

On all indoor units, service and maintenance expense is reduced due to easy-to-use cleanable filters. In addition, these high wall systems have extensive self-diagnostics to assist in troubleshooting.

## **BUILT-IN RELIABILITY**

Ductless system indoor and outdoor units are designed to provide years of trouble-free operation.

The high wall indoor units include protection against freeze-up and high evaporator temperatures on heat pumps.

The condensing units on heat pumps are protected by a three minute time delay before the compressor starts the over-current protection and the high temperature protection.

## **INDIVIDUAL ROOM COMFORT**

Maximum comfort is provided because each space can be controlled individually based on usage pattern. The air sweep feature provided permits optimal room air mixing to eliminate hot and cold spots for occupant comfort. In addition, year-round comfort can be provided with heat pumps.

## **ECONOMICAL OPERATION**

The ductless system design allows individual room heating or cooling when required. There is no need to run large supply-air fans or chilled water pumps to handle a few spaces with unique load patterns. In addition, because air is moved only in the space required, no energy is wasted while air moves through the ducts.

## **EASY-TO-USE CONTROLS**

The high wall units have microprocessor-based controls to provide the ultimate in comfort and efficiency. The user friendly wireless remote control provides the interface between the user and the unit.

## **ACCESSORIES**

Customizing these ductless systems to your application is easily accomplished. Adding a condensate pump accessory to the high wall fan coil provides installation flexibility.

## **OPTIONAL WIRED CONTROLLER**

## **AGENCY LISTINGS**

All systems are listed with AHRI (Air Conditioning, Heating & Refrigeration Institute), and are UL certified per UL 60335-2-40 standard.

# MODEL NUMBER NOMENCLATURE

## INDOOR UNIT

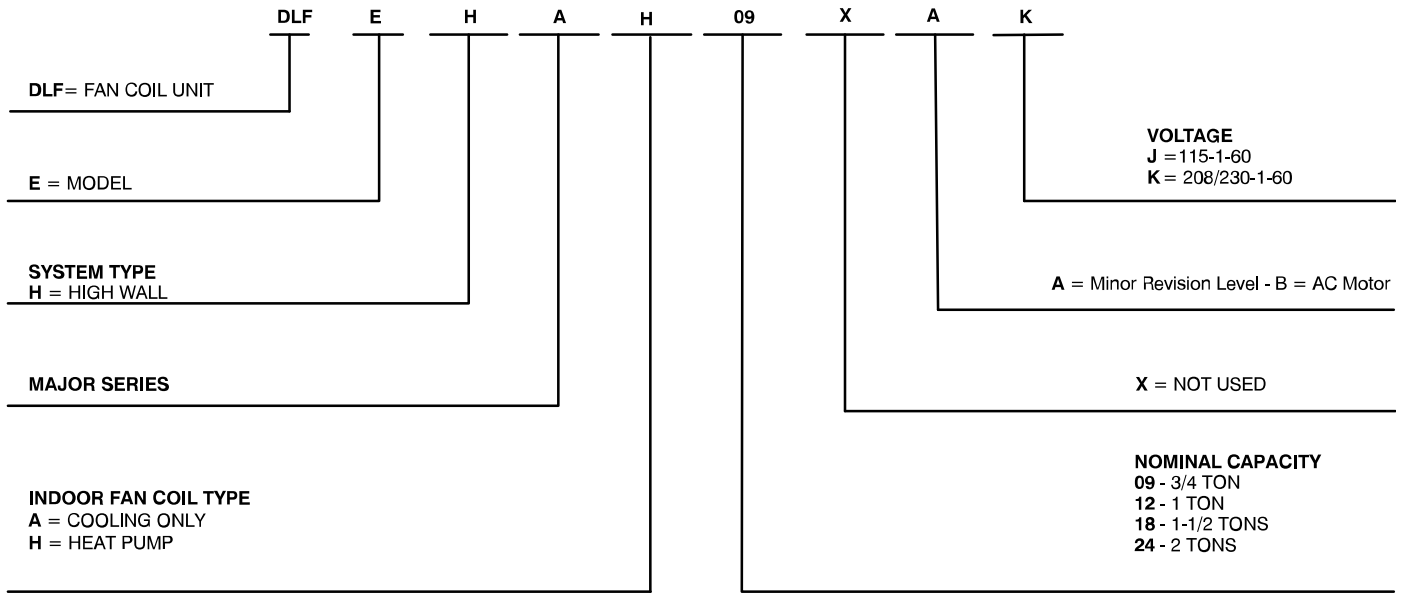

Use of the AHRI Certified TM Mark indicates a manufacturer's participation in the program. For verification of certification for individual products, go to [www.ahridirectory.org](http://www.ahridirectory.org).



## STANDARD FEATURES AND ACCESSORIES

<b>Ease Of Installation</b>	
Mounting Brackets	S
Low Voltage Controls	S
<b>Comfort Features</b>	
Microprocessor Controls	S
Wired Remote Controller	A
Wireless Remote Controller	S
Automatic Up-Down Airflow Louver Swing	S
Air Direction Control	S
Auto Restart Function	S
Cold Blow Protection on Heat Pumps	S
Freeze Protection Mode on Heat Pumps	S
Turbo Mode	S
Auto Changeover on Heat Pumps	S
Follow Me	S
<b>Energy Saving Features</b>	
Sleep Mode	S
Stop/Start Timer	S
46°F Heating Mode (Heating Setback)	S
<b>Safety And Reliability</b>	
Indoor Coil Freeze Protection	S
Indoor Coil High Temp Protection in Heating Mode	S
<b>Ease Of Service And Maintenance</b>	
Cleanable Filters	S
Diagnostics	S
<b>Application Flexibility</b>	
Condensate Pumps	A

### Legend

S - Standard  
A - Accessory

## ACCESSORIES

ACCESSORY NO.	DESCRIPTION	FOR MODELS
53DS-900---117	CONDENSATE PUMP (115V)	Size 12 (115V)
53DS-900---118	CONDENSATE PUMP (208-230V)	Sizes 09, 12, 18, 24, (208-230V)
KSACN0101AAA	WIRED REMOTE CONTROL	All Sizes
KSACN0401AAA		
KSACN0601AAA		
53DS-900---089	INSULATED 25' LINE SET - 1/4" X 3/8"	Size 09
53DS-900---008	INSULATED 25' LINE SET - 1/4" X 1/2"	Sizes 12,18

## INDOOR UNITS

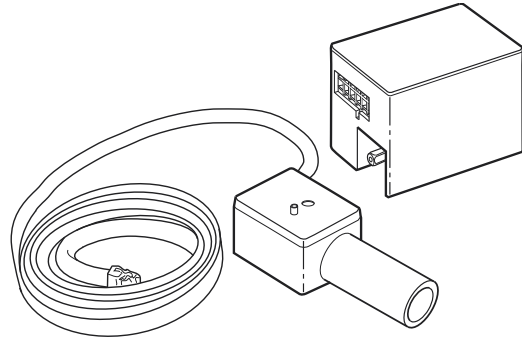

**Fig. 4 — Condensate Pump Accessory**

On high wall fan coils, the condensate pump has a lift capability of 12 ft. (3.6 m) on the discharge side with the pump mounted in the fan coil or 6 ft. (1.8 m) on the suction side if the pump is remote mounted. The pump is recommended when an adequate drain line pitch cannot be provided, or when the condensate must move up to exit.

**NOTE: An external 115v power source is required to run the pump on unit size 12k.**

# DIMENSIONS

HIGH WALL UNIT SIZE		12K (115V)	9K (208/230V)	12K (208/230V)	18K (208/230V)	24K (208/230V)
Height	In. (mm)	11.81(300)	11.81(300)	11.81(300)	12.8(325)	13.41(341)
Width	In. (mm)	32.00(813)	28.53(725)	32.00(813)	38.36(974)	43.83(1113)
Depth	In. (mm)	7.75(197)	7.75(197)	7.75(197)	8.87(225)	9.22(234)
Weight-Net (Cooling Only)	Lbs (kg)	19.62(8.9)	--	19.62(8.9)	25.35(11.5)	33.29(15.1)
Weight-Net (Heat Pump)	Lbs (kg)	19.62(8.9)	17.64(8.0)	18.74(8.5)	25.35(11.5)	33.07(15.0)

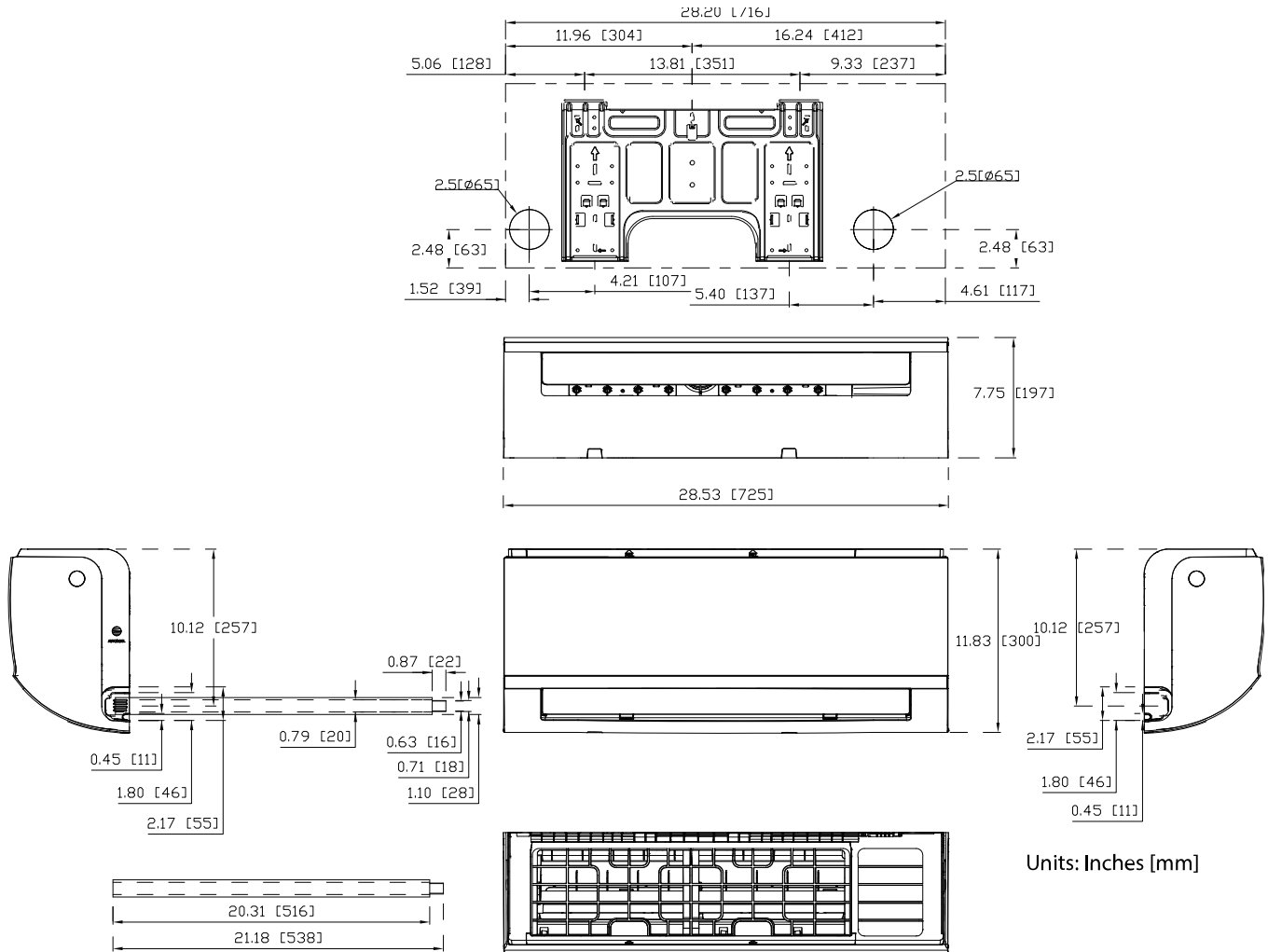
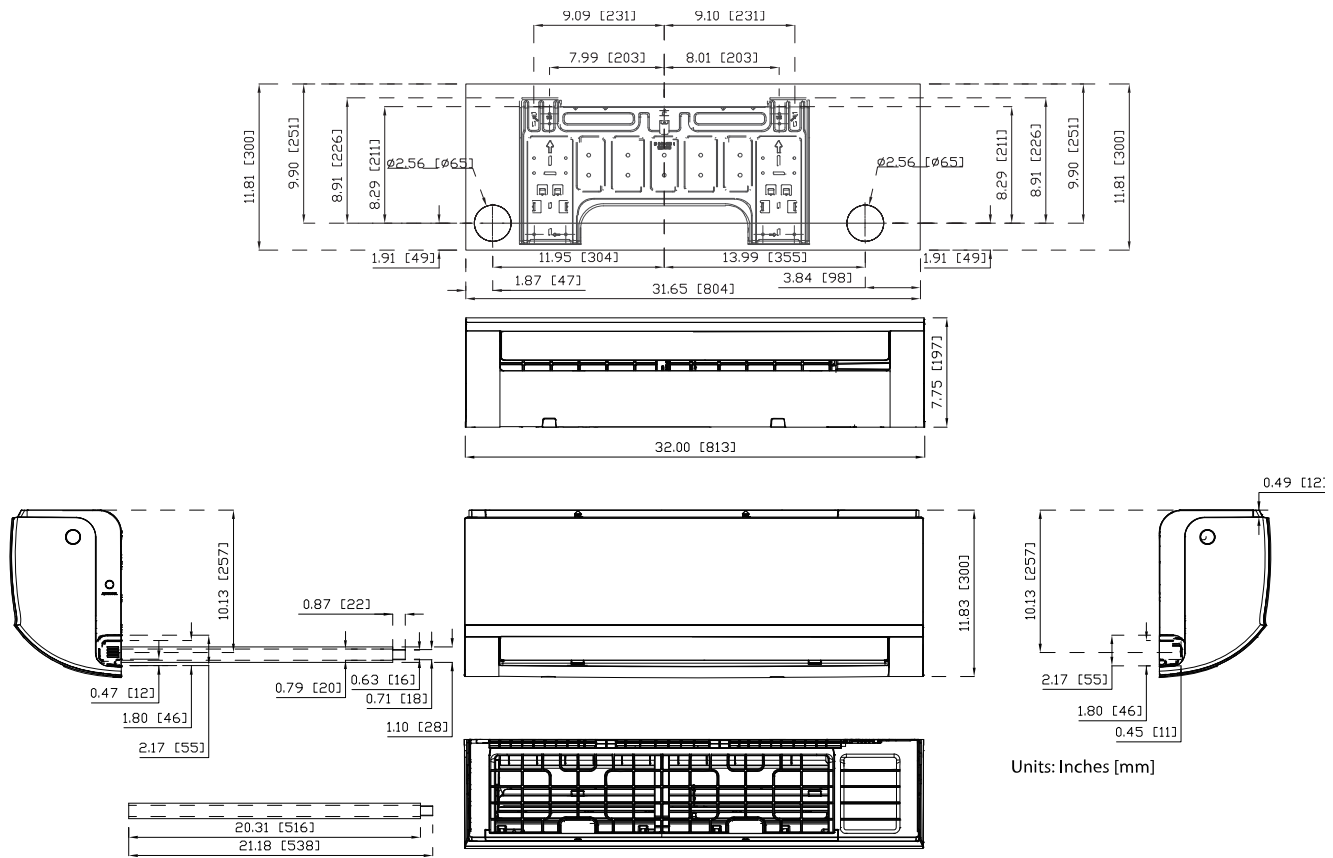

Fig. 5 — Dimensions Size 9K

# DIMENSIONS (CONT)



Units: Inches [mm]

**Fig. 6 — Dimensions Size 12K**

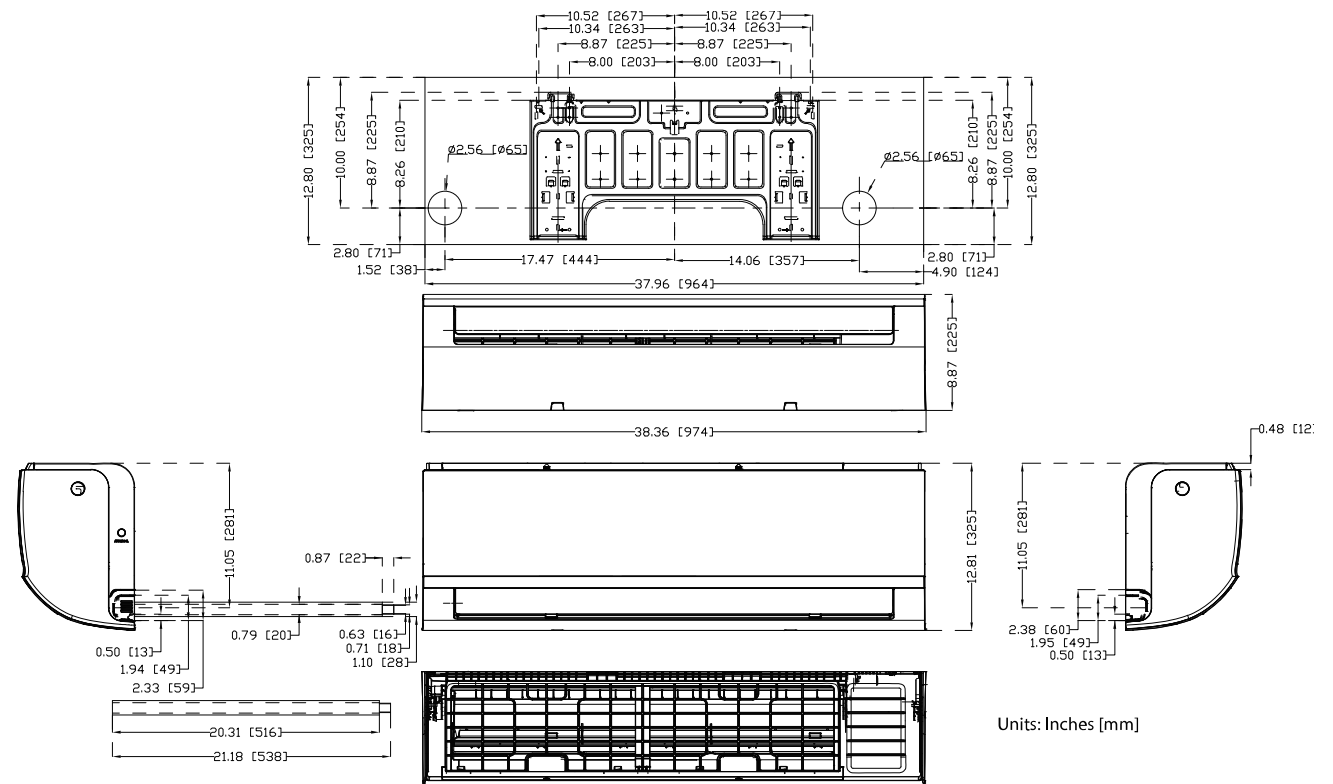

Units: Inches [mm]

**Fig. 7 — Dimensions Size 18K**

# DIMENSIONS (CONT)

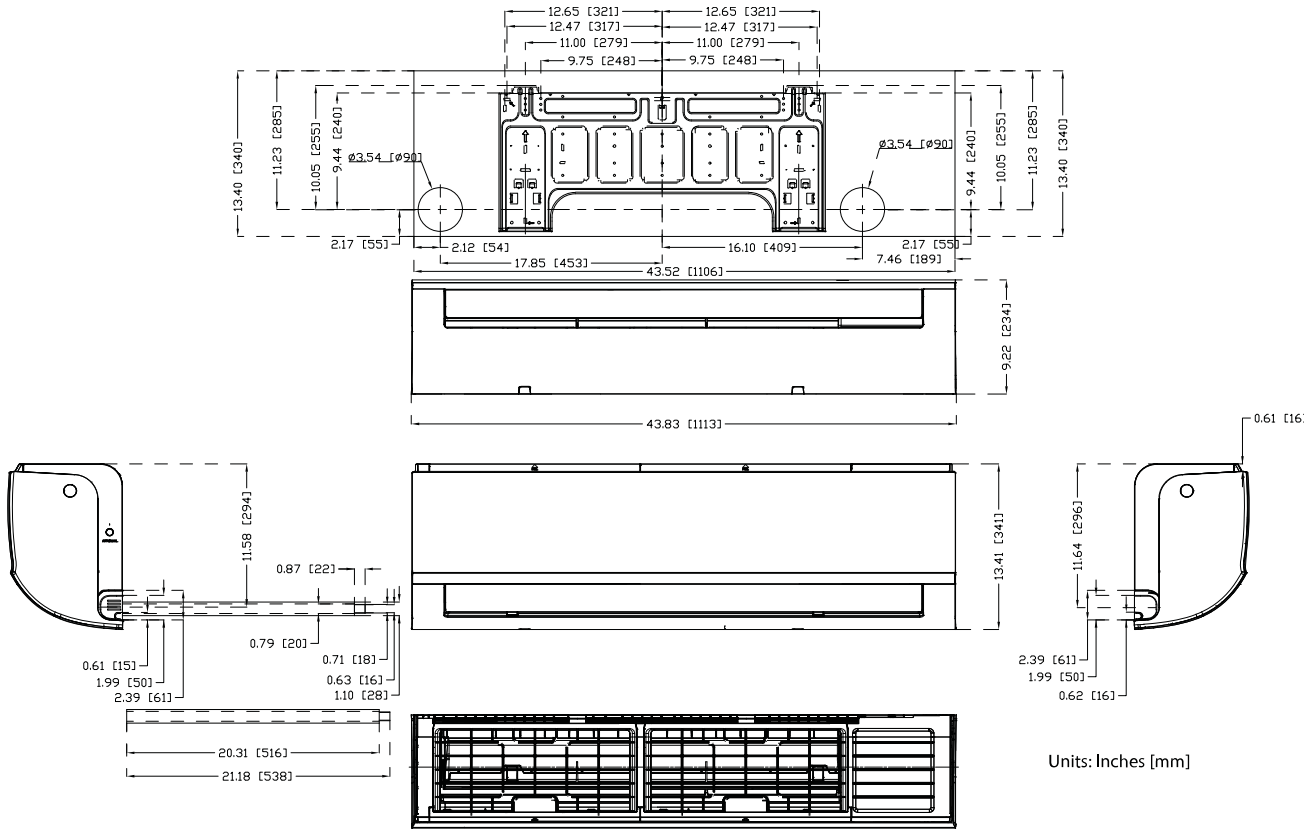
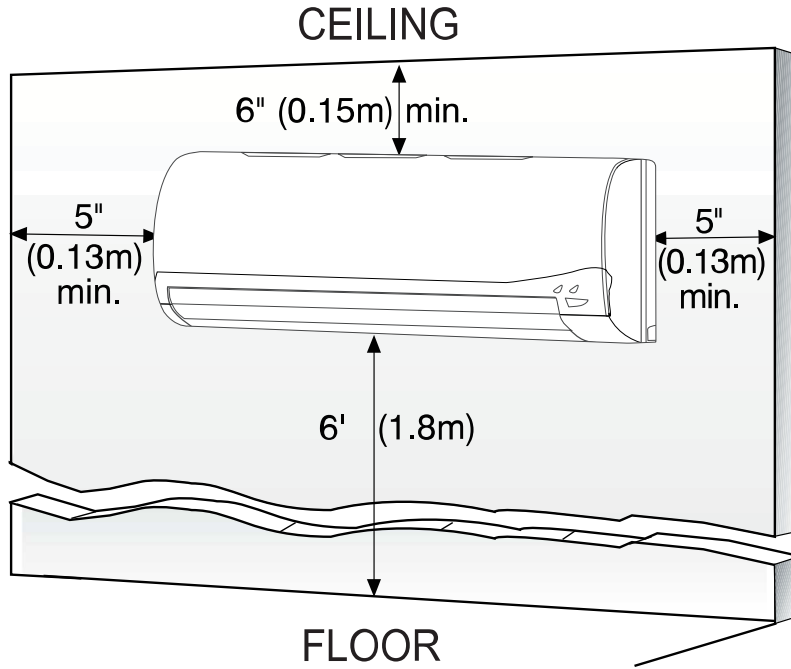

Fig. 8 — Dimensions Size 24K

# CLEARANCES



**Fig. 9 — Indoor Unit Clearances**



**SPECIFICATIONS - COOLING ONLY**

SYSTEM	SIZE		12K(115V)	12K(208/230V)	18K(208/230V)	24K(208/230V)
Electrical	Voltage, Phase, Cycle	V/Ph/Hz	115-1-60	208/230-1-60	208/230-1-60	208/230-1-60
	Power Supply		Indoor unit powered from outdoor unit			
	MCA	A.	0.2	0.1	0.27	0.4
Controls	Wireless Remote Controller (° F/° C Convertible)		Standard	Standard	Standard	Standard
	Wired Remote Controller (° F/° C Convertible)		Optional	Optional	Optional	Optional
Operating Range	Cooling Indoor DB Min - Max	° F(° C)	62~ 90 (17~ 32)	62~ 90 (17~ 32)	62~ 90 (17~ 32)	62~ 90 (17~ 32)
Piping	Pipe Connection Size - Liquid	in (mm)	1/4 (6.35)	1/4 (6.35)	1/4 (6.35)	3/8 (9.52)
	Pipe Connection Size - Suction	in (mm)	1/2 (12.7)	1/2 (12.7)	1/2 (12.7)	5/8 (16)
Indoor Coil	Face Area (sq. ft.)	Sq. Ft.	1.76	1.76	2.71	2.78
	No. Rows		2	2	2	2
	Fins per inch		21/20	21/20	21	20
	Circuits		3	3	4	5
Indoor	Unit Width	in (mm)	32.00 (813)	32.00 (813)	38.36 (974)	43.83 (1113)
	Unit Height	in (mm)	11.81 (300)	11.81 (300)	12.8 (325)	13.41 (341)
	Unit Depth	in (mm)	7.75 (197)	7.75 (197)	8.87 (225)	9.22 (234)
	Net Weight	lbs (kg)	19.62 (8.9)	19.62 (8.9)	23.35 (11.5)	33.29 (15.1)
	Fan Speed #		4	4	4	4
	Airflow (lowest to highest)	CFM	198/237/331/362	191/237/334/362	344/422/505/505	418/506/600/629
	Sound Pressure (lowest to highest)	dB(A)	27/33/42/44	29/33/42/45	36/40/44/45	35/41/46/48
	Air throw Data	ft (m)	22 (6.7)	22 (6.7)	24 (7.3)	39.4 (12)
	Moisture removal	Pint/h (L/h)	3.17 (1.50)	3.09 (1.46)	4.38 (2.07)	6.38 (3.02)
Field Drain Pipe Size O.D.	in (mm)	0.625 (16)	0.625 (16)	0.625 (16)	0.625 (16)	

\*Performance may vary based on the compatible outdoor units. See respective pages for performance data.

**NOTE: See the current compatibility charts for a list of the indoor unit and outdoor unit match ups.**

**SPECIFICATIONS - HEAT PUMP**

SYSTEM	SIZE		12K(115V)	9K(208/230V)	12K(208/230V)	18K(208/230V)	24K(208/230V)
Electrical	Voltage, Phase, Cycle	V/Ph/Hz	115-1-60	208/230-1-60	208/230-1-60	208/230-1-60	208/230-1-60
	Power Supply		Indoor unit powered from outdoor unit				
	MCA	A.	0.2	0.22	0.1	0.27	0.27
Controls	Wireless Remote Controller (° F/° C Convertible)		Standard	Standard	Standard	Standard	Standard
	Wired Remote Controller (° F/° C Convertible)		Optional	Optional	Optional	Optional	Optional
Operating Range	Cooling Indoor DB Min - Max	° F(° C)	62~ 90 (17~ 32)	62~ 90 (17~ 32)	62~ 90 (17~ 32)	62~ 90 (17~ 32)	62~ 90 (17~ 32)
	Heating Indoor DB Min - Max	° F(° C)	32~ 86 (0~ 30)	32~ 86 (0~ 30)	32~ 86 (0~ 30)	32~ 86 (0~ 30)	32~ 86 (0~ 30)
Piping	Pipe Connection Size - Liquid	in (mm)	1/4 (6.35)	1/4 (6.35)	1/4 (6.35)	1/4 (6.35)	3/8 (9.52)
	Pipe Connection Size - Suction	in (mm)	1/2 (12.7)	3/8 (9.52)	1/2 (12.7)	1/2 (12.7)	5/8 (16)
Indoor Coil	Face Area (sq. ft.)	Sq. Ft.	1.76	1.50	1.76	2.71	2.97
	No. Rows		2	2	2	2	2
	Fins per inch		21/20	21	21	21	21
	Circuits		3	2	2	2	2
Indoor	Unit Width	in (mm)	32.00 (813)	28.53 (725)	32.00 (813)	38.36 (974)	43.83 (1113)
	Unit Height	in (mm)	11.81 (300)	11.81 (300)	11.81 (300)	12.8 (325)	13.41 (341)
	Unit Depth	in (mm)	7.75 (197)	7.75 (197)	7.75 (197)	8.87 (225)	9.22 (234)
	Net Weight	lbs (kg)	19.62(8.9)	17.64 (8.0)	18.74(8.5)	25.35(11.5)	33.07(15.0)
	Fan Speeds		4	4	4	4	4
	Airflow (lowest to highest)	CFM	200/265/306/329	153/253/282/324	212/282/324/353	353/412/529/559	353/471/588/647
	Sound Pressure (lowest to highest)	dB(A)	29/35/41/43	30/37/41/43	31/36/42/43	32/36/43/45	35/41/47/48
	Air throw Data	ft (m)	22 (6.7)	20.3 (6.2)	22.6 (6.9)	25 (7.6)	37.7 (11.5)
	Moisture removal	Pint/h (L/h)	3.51 (1.66)	2.37 (1.12)	3.43 (1.62)	4.67 (2.21)	5.28 (2.64)
Field Drain Pipe Size O.D.	in (mm)	0.625 (16)	0.625 (16)	0.625 (16)	0.625 (16)	0.625 (16)	

**NOTE: See the current compatibility charts for a list of the indoor unit and outdoor unit match ups.**

## APPLICATION DATA

### UNIT SELECTION

Select equipment that either matches or is supports slightly more than the anticipated peak load. This provides better humidity control, fewer unit cycles, and less part-load operation.

For units used in spaces with high sensible loads, base equipment selection on unit sensible load, not on total anticipated load. Adjust for anticipated room wet bulb temperature to avoid undersizing the equipment.

### UNIT MOUNTING (INDOOR)

Refer to the unit's installation instructions for further details.

**Unit leveling** - For reliable operation, units should be level in all planes.

**Clearance** - Provide adequate clearance for airflow (see Fig. 9 — on page 8).

**Unit location** - Select a location which provides the best air circulation for the room. These units should be positioned as high as possible on the wall for the best air circulation. The unit return and discharge should not be obstructed by furniture, curtains, or anything which may cause unit short cycling or air recirculation.

Place the unit in the middle of the selected wall (if possible). Use an outside wall, if available, to make piping easier, and place the unit so it faces the normal location of room occupants.

### UNIT MOUNTING (OUTDOOR)

Refer to the unit's installation instructions for further details.

Do not install the indoor or outdoor units in a location with special environmental conditions. For those applications, contact your Ductless representative.

### MOUNTING TEMPLATE

Refer to the unit's installation instructions for further details.

The fan coil units are furnished with mounting to mark the location of the wiring, and the refrigeration line hole locations.

### SUPPORT

Adequate support must be provided to support the weight of all the fan coils. Refer to the Physical Data section for fan coil weights, and the base unit dimensional drawings for the mounting bracket locations.

### SYSTEM OPERATING CONDITIONS

OPERATING RANGE MIN/MAX °F/°C		
	COOLING	HEATING
Indoor DB	62 / 90 (17 / 32)	32 / 86 (0 / 30)

**NOTE:** Reference the product installation instructions for more information.

### DRAIN CONNECTIONS

Install drains to meet the local sanitation codes. If adequate gravity drainage cannot be provided, the unit should be equipped with an accessory condensate pump. The high wall fan coil unit condensate pumps have a maximum lift of 10' (3.05 m) for 9k and 12k units and 25' (7.62 m) for 18k and 24k units.

See the physical dimension tables for the drain sizes.

**NOTE:** High wall fan coil units have internal condensate traps. A trap is not required.

Drain connections may be routed through alternate locations on most fan coils (see Fig. 10).

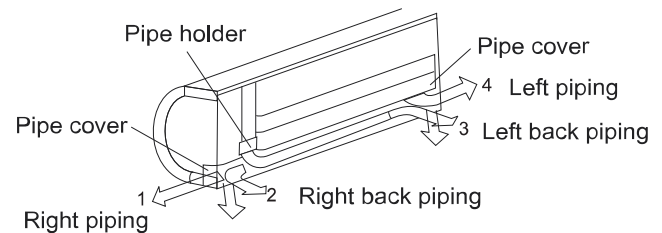

**Fig. 10 — Piping Connections**

## WIRING

All wires must be sized per NEC (National Electrical Code) or CEC (Canadian Electrical Code) and local codes. Per the caution note, only stranded copper conductors with a 600 volt rating and double insulated copper wire must be used.

The use of BX cable is not recommended.

### Recommended Connection Method for Power and Communication Wiring - Power and Communication Wiring:

The main power is supplied to the outdoor unit. The field supplied 14/3 power/communication wiring from the outdoor unit to indoor unit consists of four (4) wires and provides the power for the indoor unit. Two wires are high voltage AC power, one is communication wiring and the other is a ground wire.

### Recommended Connection Method for Power and Communication Wiring (To minimize communication wiring interference)

#### Power Wiring:

The main power is supplied to the outdoor unit. The field supplied power wiring from the outdoor unit to indoor unit consists of three (3) wires and provides the power for the indoor unit. Two wires are high voltage AC power and one is a ground wire.

To minimize voltage drop, the factory recommended wire size is 14/2 stranded with a ground.

#### Communication Wiring:

A separate shielded Stranded copper conductor only, with a 600 volt rating and double insulated copper wire, must be used as the communication wire from the outdoor unit to the indoor unit.

Please use a separate shielded 16GA stranded control wire.

CAUTION

**EQUIPMENT DAMAGE HAZARD**  
Failure to follow this caution may result in equipment damage or improper operation.

Be sure to comply with local codes while running wire from the indoor unit to the outdoor unit.

Every wire must be connected firmly. Loose wiring may cause the terminal to overheat or result in unit malfunction. A fire hazard may also exist. Ensure all wiring is tightly connected.

No wire should touch the refrigerant tubing, compressor or any moving parts.

Disconnecting means must be provided and shall be located within sight and readily accessible from the air conditioner.

Connecting cable with conduit shall be routed through the hole in the conduit panel.

## CONTROL SYSTEM

The indoor unit is equipped with a microprocessor control to perform two functions:

1. Provide safety for the system
2. Control the system and provide optimum levels of comfort and efficiency.

The main microprocessor is located on the control board of the fan coil unit (outdoor units also have a microprocessor) with thermistors located in the fan coil air inlet and on the indoor coil.

The heat pump units have a thermistor on the outdoor coil. These thermistors monitor the system operation to maintain the unit within acceptable parameters and controls the operating mode.

### Wireless Remote Control



**Fig. 11 — Wireless Remote Control**

1. A wireless remote control is supplied for system operation for system operation of all high wall units.
2. Each battery operated wireless (infrared) remote control may be used to control more than one unit.

### WIRED REMOTE CONTROL (OPTIONAL)

P/N KSACN0401AAA (7 day programmable)

1. Optional wired remote controller used for system operation of all high wall units.
2. Kit includes a wired remote controller and a connecting cable.
3. Connect with wire terminal between remote controller and indoor unit.
4. Display in °F or °C and temperature increments every 1°F or every 1°C.

CAUTION

**EQUIPMENT DAMAGE HAZARD**  
Failure to follow this caution may result in equipment damage or improper operation.

Wires should be sized based on NEC and local codes.

Use copper conductors only with a 600 volt rating and double insulated copper wire.

## AIR FLOW DATA

COOLING ONLY		12K (115V)		12K (208/230V)	18K (208/230V)	24K (208/230V)
Indoor (CFM)	Turbo	361.76		361.76	505.29	629.41
	High	331.18		333.53	505.29	600.00
	Medium	237.06		237.06	421.76	505.88
	Low	198.24		191.18	344.12	417.65
HEAT PUMP		12K (115V)	9K (208/230V)	12K (208/230V)	18K (208/230V)	24K (208/230V)
Indoor (CFM)	Turbo	329.41	323.53	352.94	558.82	647.06
	High	305.88	282.35	323.53	529.41	588.24
	Medium	264.71	252.94	282.35	411.76	470.59
	Low	200.00	152.94	211.76	352.94	352.94

## AIR THROW DATA

HIGH WALL UNIT CAPACITY	MAX. APPROXIMATE AIR THROW FT. (M)	APPROXIMATE AIR THROW RANGE. (M)
<b>COOLING ONLY</b>		
12K (115)	22 (6.7)	4.6~22.6 (1.4~6.9)
12K (208)	22 (6.7)	4.6~22.6 (1.4~6.9)
18K (208)	24 (7.3)	4.6~29.5 (1.4~9.0)
24K (208)	39.4 (12)	7.2~44.9 (2.2~13.7)
<b>HEAT PUMP</b>		
12K (115)	22 (6.7)	4.6~22.6 (1.4~6.9)
9K (208)	20.3 (6.2)	4.6~20.7 (1.4~6.3)
12K (208)	22.6 (6.9)	4.6~23.6 (1.4~7.2)
18K (208)	25 (7.6)	4.6~30.2 (1.4~9.2)
24K (208)	37.7 (11.5)	5.9~43.3 (1.8~13.3)

## MOISTURE REMOVAL

COOLING ONLY						
SIZE		12K		12K	18K	24K
Voltage, Phase, Cycle	V/Ph/Hz	115-1-60		208/230-1-60	208/230-1-60	208/230-1-60
Dehumidifying volume	L/h	1.50		1.46	2.07	3.02
Dehumidifying volume	PINT/h	3.17		3.09	4.38	6.38
<b>HEAT PUMP</b>						
SIZE		12K	9K	12K	18K	24K
Voltage, Phase, Cycle	V/Ph/Hz	115-1-60	208/230-1-60	208/230-1-60	208/230-1-60	208/230-1-60
Dehumidifying volume	L/h	1.66	1.12	1.62	2.21	2.64
Dehumidifying volume	PINT/h	3.51	2.37	3.43	4.67	5.58

## SOUND PRESSURE

COOLING ONLY		12K (115V)		12K (208/230V)	18K (208/230V)	24K (208/230V)
Cooling Operation Indoor	DbA at (High / Med / Low CFM)	44.3/42.3/27.1		44.5/42.1/33.2/28.7	45.2/43.9/39.8/36	47.7/45.5/41.3/34.9
HEAT PUMP		12K (115V)	9K (208/230V)	12K (208/230V)	18K (208/230V)	24K (208/230V)
Cooling Operation Indoor	DbA at (High / Med / Low CFM)	42.5/40.6/34.7/29.2	42.8/41.2/36.5/29.9	42.5/40.3/34.1/29.7	45.2/43.2/36.2/32.1	48.4/46.6/40.5/34.6
Heating Operation Indoor Sound Pressure		41.6/41.1/33.6/28.5	42.4/41/35/30.3	42.7/41.9/35.5/30.5	44.4/42.3/35.6/32.4	47.7/42.4/40.9/34.6

## FAN AND MOTOR SPECIFICATIONS

HIGH WALL UNIT SIZE		12K(115V)	12K(208/230V)	18K(208/230V)	24K(208/230V)
HIGH WALL FAN	Material	Acrylontrile Styrene +30%GF	Acrylontrile Styrene +30%GF	A Acrylontrile Styrene +30%GF	Acrylontrile Styrene +30%GF
	Type	GL-94*605-N	GL-94*605-N	GL-98*758-I	GL-108*818
	Diameter	In (mm) 3.7(94)	3.7(94)	3.86(98)	4.25(108)
	Height	In (mm) 23.82(605)	23.82(605)	29.84(758)	32.2(818)
HIGH WALL FAN MOTOR	Model	ZKFP-20-8-113	ZKFP-20-8-6-7	YKFG-28-4-6-5	YKFG-45-4-13
	Volts	V 140	310	220	310
	Phase	1	1	1	1
	FLA	0.4	0.4	0.4	0.45
	Type	DC	DC	AC	DC
	Insulation class	E	E	E	E
	Safe class	IP20	IPX0	IPX0	IPX0
	Input	W 65.8	50	58.5	89
	Output	W 20	20	28	45
	Range of current	Amps 0.2±10%	0.1±10%	0.27±10%	0.4±10%
	Rated current	Amps 0.2	0.1	0.27	0.4
	Capacitor	µF NA	NA	1.5	NA
	Rated HP	HP 0.027	0.027	0.037	0.06
	Speed	rev/min 1200/900/760	1200/900/760	1150/1000/850	1150/1000/800
	Rated RPM	rev/min 1200	1200	1150	1150
Max. input	W 65.8	50	58.5	89	

HIGH WALL UNIT SIZE		12K(115 V)	9K(208/230 V)	12K(208/230 V)	18K(208/230 V)	24K(208/230 V)
HIGH WALL FAN	Material	Acrylontrile Styrene +30%GF	Acrylontrile Styrene +30%GF	Acrylontrile Styrene +30%GF	A Acrylontrile Styrene +30%GF	Acrylontrile Styrene +30%GF
	Type	GL-94*605-N	GL-94*516-I	GL-94*605-N	GL-98*758-I	GL-108*818
	Diameter	In (mm) 3.7(94)	3.7(94)	3.7(94)	3.86(98)	4.25(108)
	Height	In (mm) 23.82(605)	20.31(516)	23.82(605)	29.84(758)	32.2(818)
HIGH WALL FAN MOTOR	Model	ZKFP-20-8-113	YKFG-20-4-10L	ZKFP-20-8-6-7	YKFG-28-4-6-5	ZKFP-58-8-1-5
	Volts	V 140	220	310	220	310
	Phase	3	3	3	1	3
	FLA	0.47	0.34	0.34	0.4	0.45
	Type	DC	AC	DC	AC	DC
	Insulation class	E	E	E	E	E
	Safe class	IP20	IPX0	IP20	IPX0	IP20
	Input	W 25	21	21	58.5	62
	Output	W 20	20	20	28	58
	Range of current	Amps 0.2±10%	0.218±10%	0.1±10%	0.27±10%	0.27±10%
	Rated current	Amps 0.2	0.218	0.1	0.27	0.27
	Capacitor	µF NA	1.5	NA	1.5	NA
	Rated HP	HP 0.027	0.027	0.027	0.037	0.077
	Speed	rev/min 1100/900/750	1080/900/700	1080/900/700	1150/900/800	1150/950/750
	Rated RPM	rev/min 1100	1080	1080	1150	1150
Max. input	W 65.8	47.4	65.8	58.5	58	

# WIRING DIAGRAMS

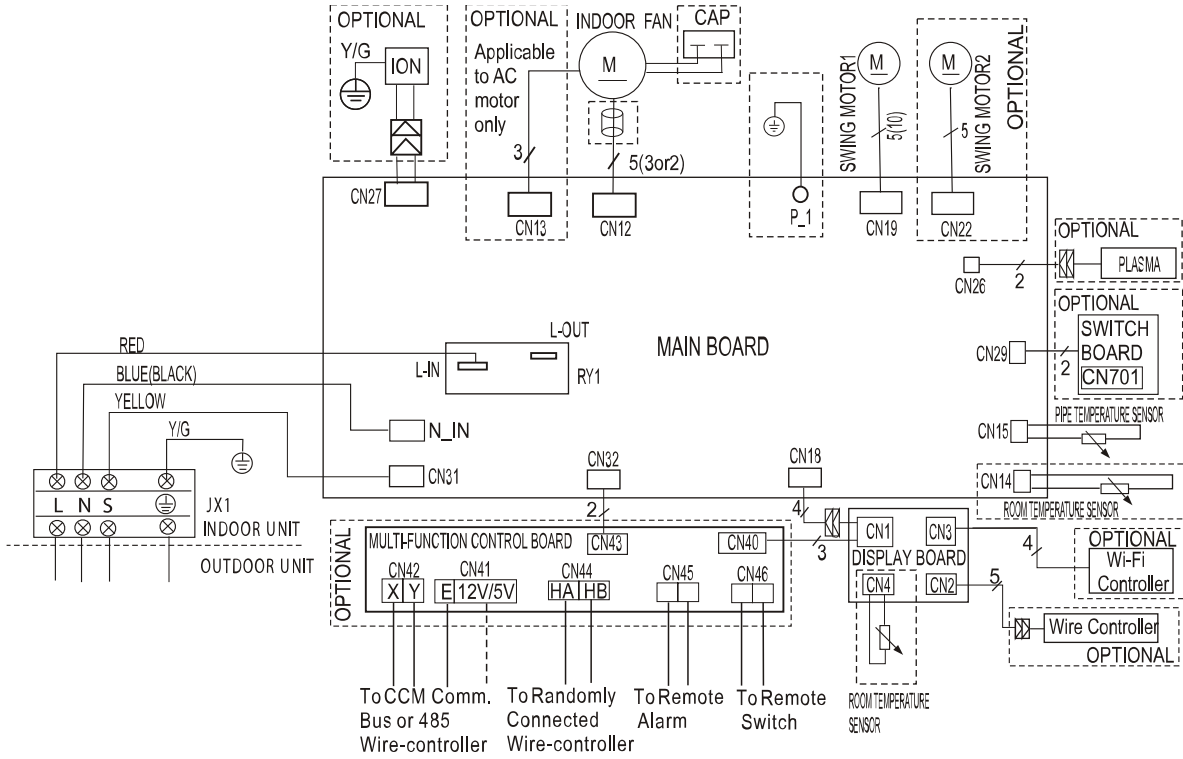

---- This symbol indicates the element is optional, the actual shape shall prevail.

**FOR SETTING NETADDRESS (CCM Comm.Bus)**

	ENC 3+F1 (MULTI-FUNCTION CONTROL BOARD)	ENC 3+F1 (MULTI-FUNCTION CONTROL BOARD)	ENC 3+F1 (MULTI-FUNCTION CONTROL BOARD)	ENC 3+F1 (MULTI-FUNCTION CONTROL BOARD)
CODE	0~F	0~F	0~F	0~F
NETADDRESS	0~15	16~31	32~47	48~63
FACTORY SETTING	✓			

**Fig. 12 — Wiring Diagram Size 12 (115V)**

# WIRING DIAGRAM (CONT)

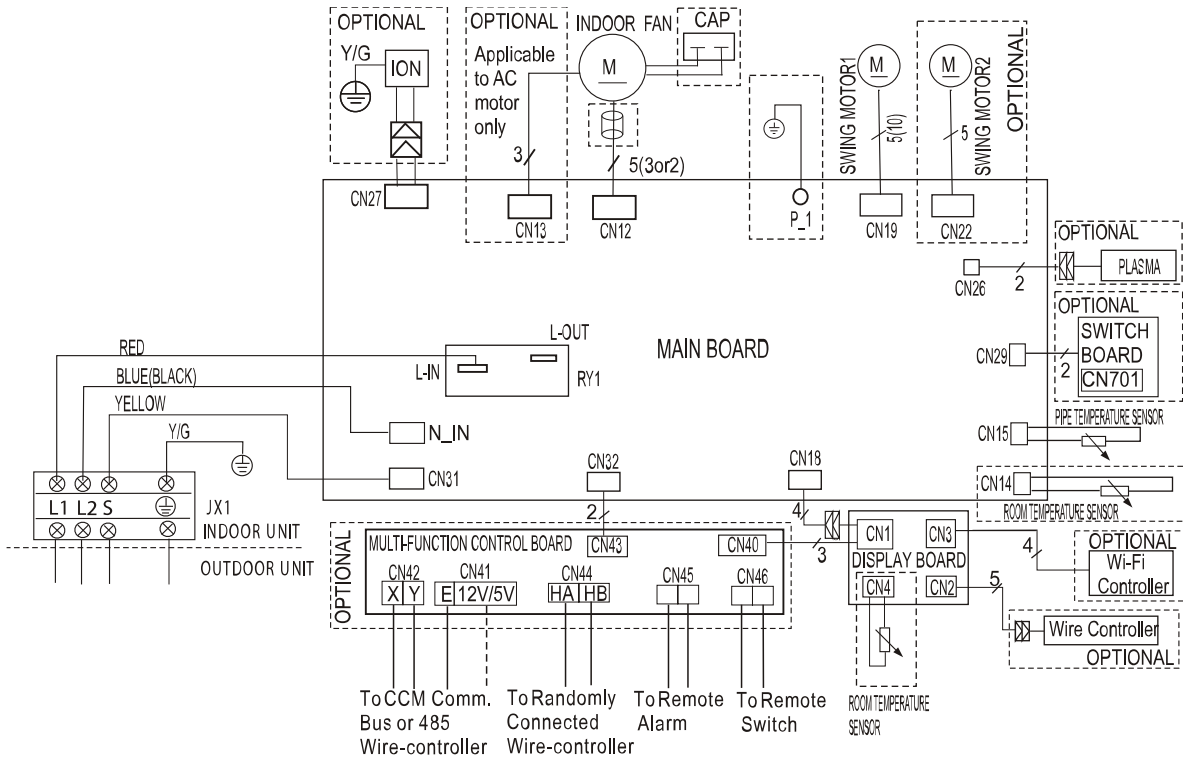

**FOR SETTING NETADDRESS (CCM Comm.Bus)**

---- This symbol indicates the element is optional, the actual shape shall prevail.

ENC 3+F1 (MULTI-FUNCTION CONTROL BOARD)	ENC 3+F1 (MULTI-FUNCTION CONTROL BOARD)	ENC 3+F1 (MULTI-FUNCTION CONTROL BOARD)	ENC 3+F1 (MULTI-FUNCTION CONTROL BOARD)
<b>CODE</b>	0~F	0~F	0~F
<b>NETADDRESS</b>	0~15	16~31	32~47
<b>FACTORY SETTING</b>	✓		

**Fig. 13 — Wiring Diagram Sizes 09-24 (208-230V)**

# GUIDE SPECIFICATIONS

## INDOOR AIR HANDLER DUCTLESS SYSTEMS

Size Range: 3/4 to 2 Ton Nominal Cooling and Heating Capacity Model  
Number: **DLFEHA**

### Part 1 - GENERAL

#### 1.01 System Description

Indoor, wall-mounted, direct-expansion fan coils are matched with the cooling only or the heat pump outdoor unit.

#### 1.02 Agency Listings

Unit is rated per AHRI Standards 210/240 and listed in the AHRI directory as a matched system.

#### 1.03 Delivery, Storage, And Handling

Units are stored and handled per the unit manufacturer's recommendations.

#### 1.04 Warranty (For Inclusion By Specifying Engineer)

### Part 2 - PRODUCTS

#### 2.01 Equipment

##### **A. General:**

Indoor, direct-expansion, ceiling-mounted fan coil. The unit is complete with a cooling/heating coil, fan, fan motor, piping connectors, electrical controls, microprocessor control system, and integral temperature sensing. The unit is furnished with an integral wall mounting bracket and mounting hardware.

##### **B. Unit Cabinet:**

The cabinet discharge and inlet grilles are attractively styled, high-impact polystyrene. The cabinet is fully insulated for improved thermal and acoustic performance.

##### **C. Fans:**

1. Fan is the tangential direct-drive blower type with air intake at the top of the unit and discharge at the bottom front. An automatic, motor-driven vertical air sweep is provided as standard equipment.
2. The air sweep operation is user selectable. The vertical sweep may be adjusted (using the remote control). The horizontal air direction may be set manually.

##### **D. Coil:**

The coil is a copper tube with aluminum fins and galvanized steel tube sheets. The fins are bonded to the tubes by mechanical expansion and blue hydrophilic pre-coated. A drip pan, under the coil, has a drain connection for the hose attachment to remove condensate. The condensate pan has an internal trap.

##### **E. Motors:**

The motors are open drip-proof, with a permanently lubricated ball bearing. The fan motors are 4-speed.

##### **F. Controls:**

The controls consist of a microprocessor-based control system which controls the space temperature, determines the optimum fan speed, and runs self diagnostics. The temperature control range is from 62°F to 86°F (17°C to 30°C) in increments of 1°F or 1°C, and have 46°F Heating Mode (Heating Setback). The wireless remote controller has the ability to act as the temperature sensing location for room comfort.

#### **The unit has the following functions (at a minimum):**

1. An automatic restart after a power failure at the same operating conditions as at the failure.
2. A timer function to provide a minimum 24-hour timer cycle for system Auto Start/Stop.
3. Temperature-sensing controls have sense return air temperature.
4. Indoor coil freeze protection.
5. Wireless infrared remote control to enter set points and operating conditions.
6. Automatic air sweep control to provide on or off activation of air sweep louvers.
7. Dehumidification mode provides increased latent removal capability by modulating the system operation and the set point temperature.
8. Fan-only operation to provide room air circulation when no cooling is required.
9. Diagnostics provide continuous checks of unit operation and warn of possible malfunctions. Error messages appear on the unit.
10. Fan speed control is user-selectable: turbo, high, medium, low, or microprocessor controlled automatic operation during all operating modes.
11. Automatic heating-to-cooling changeover in the heat pump mode. The control includes a deadband to prevent rapid mode cycling between heating and cooling.
12. Indoor coil high temperature protection are provided to detect excessive indoor discharge temperature when the unit is in the heat pump mode.

##### **G. Filters:**

Unit has a filter track with factory-supplied cleanable filters.

##### **H. Electrical Requirements:**

Indoor fan motor to operate on 115V on model size 12 and on 208-230V on model sizes 09-24, as specified. Power is supplied by the outdoor unit.

##### **I. Operating Characteristics:**

The system has a minimum SEER (Seasonal Energy Efficiency Ratio) and HSPF at AHRI conditions, as listed on the specifications table.

##### **J. Refrigerant Lines:**

All units should have refrigerant lines that can be oriented to connect from the left, right or back of unit. Both refrigerant lines need to be insulated.

##### **K. Special Features (Field Installed):**

The condensate pump removes condensate from the drain pan when gravity drainage cannot be used. The pump is designed for quiet operation. The pump consists of two parts: an internal reservoir/sensor assembly, and a remote sound-shielded pump assembly. A liquid level sensor in the reservoir stops the cooling operation if the liquid level in the reservoir is unacceptable.