

Installation Instructions

Round Barometric Bypass Damper

DAMPBAR

NOTE: Read the entire instruction manual before starting the installation.

SAFETY CONSIDERATIONS

Read and follow these Installation Instructions carefully. Follow all safety codes. Wear safety glasses and work gloves.

Recognize safety information. This is the safety-alert symbol . When you see this symbol on the unit and in instructions or manuals, be alert to the potential for personal injury.

Understand the signal words DANGER, WARNING, and CAUTION. These words are used with the safety-alert symbol. DANGER identifies the most serious hazards which **will** result in severe personal injury or death. WARNING signifies hazards which **could** result in personal injury or death. CAUTION is used to identify unsafe practices which **would** result in minor personal injury or product and property damage.

SPECIFICATIONS

Operating Range: -10° to 175°F (-23° to 80°C)

Pressure Range: 0.20 to 0.80 in. wc.

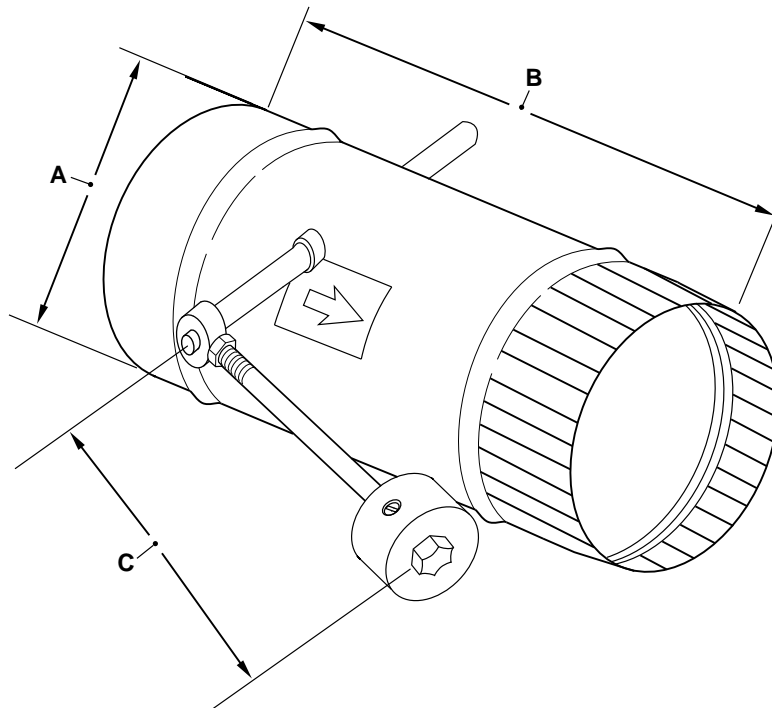

A98374

MODEL NO.	A	B	C	MAXIMUM AIR-FLOW (CFM)
DAMPBAR08INC	8	9	6	400
DAMPBAR10INC	10	11-1/8	8	650
DAMPBAR12INC	12	13-1/8	10	900
DAMPBAR14INC	14	15-3/8	10	1200
DAMPBAR16INC	16	17-5/8	12	1600

Fig. 1—Round Barometric Bypass Dimensions (In.)

INTRODUCTION

The Round Barometric Bypass Damper is used to limit air pressure in a zoning installation while closed zones would otherwise overly restrict the airflow, allowing pressure to build. Air is taken from the supply plenum to relieve pressure buildup. The reason for limiting pressure is only to limit air noise to a level acceptable to the homeowner. If noise is never objectionable, the damper will never need to open and could be eliminated. However, since many factors influence air noise, it is good practice to install a bypass unless the designer is certain that it is not needed. Note that this means an installed damper may never need to open.

This damper uses an adjustable weight on an arm to hold the damper closed until the supply duct pressure exceeds a preset value. The damper then begins to open, limiting the duct pressure. The position of the weight on the arm determines the opening pressure.

NOTE: Because the operating pressures and control forces are relatively small, **ensure there is no binding or drag on the damper blade after installation.** Failure to verify this may prevent the damper from operating properly.

INSTALLATION

PROCEDURE 1—DETERMINE THE BYPASS SIZING AND METHOD — DIRECT RETURN OR DUMP ZONE

The bypass method determines the destination (return plenum or dump zone) of the bypassed air and therefore affects the location of the bypass damper. The size should be sufficient to bypass 25 percent of the total system airflow. For more information on making these selections, consult the Zoning Design Guide. See Fig. 2 for direct return installation and Fig. 3 for dump zone installation.

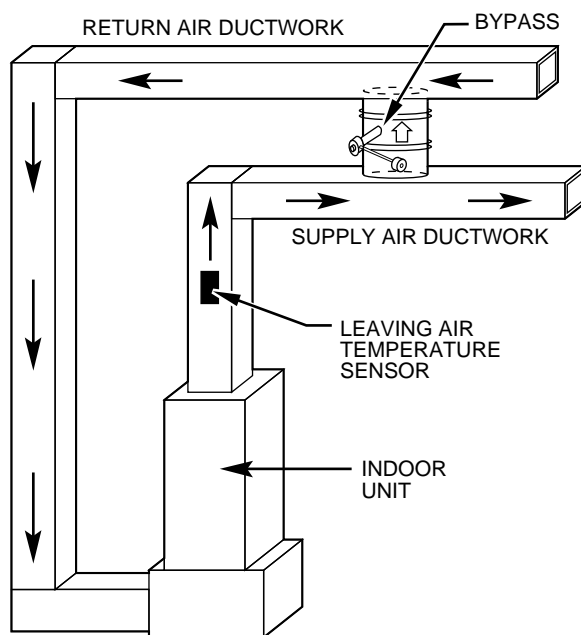

Fig. 2—Direct Return Installation

A98375

PROCEDURE 2—FIND A LOCATION

Consider each of the following before starting the actual installation of the damper:

1. The location of the bypass damper should be accessible to allow inspection and adjustment after installation.
2. The air must flow through the damper in the direction indicated by the "airflow" arrow.
3. The bypass damper may be mounted in any of the 4 positions with airflow up, down, right, or left with the air flowing in the direction of the "airflow" arrow. However, when positioned horizontal (airflow left or right), it must be mounted with the shaft above center. (See Fig. 4—7.)
4. The damper shaft must be free to rotate to a full 90° upward from closed (4:00 up to 1:00 for counterclockwise rotation, or 8:00 up to 11:00 for clockwise rotation).
5. The addition of a bypass reduces the leaving air temperature (LAT) in cooling. This will increase the duct's tendency to sweat while cooling. If sweating may be a problem, insulate the damper appropriately, making sure the insulation does not interfere with the movement of the arm.
6. When using the direct method, connect the return upstream from (ahead of) the air inlet filter. This prevents filter pressure drop from acting to open the bypass damper.
7. The leaving air temperature sensor must be mounted in the supply air stream upstream from the bypass inlet. This assures the sensor is measuring actual leaving air temperature. Make room for this.
8. When using flexible duct, mount or suspend damper firmly so that it can support the flexible duct. Special care should be used not to restrict or kink the flexible duct.

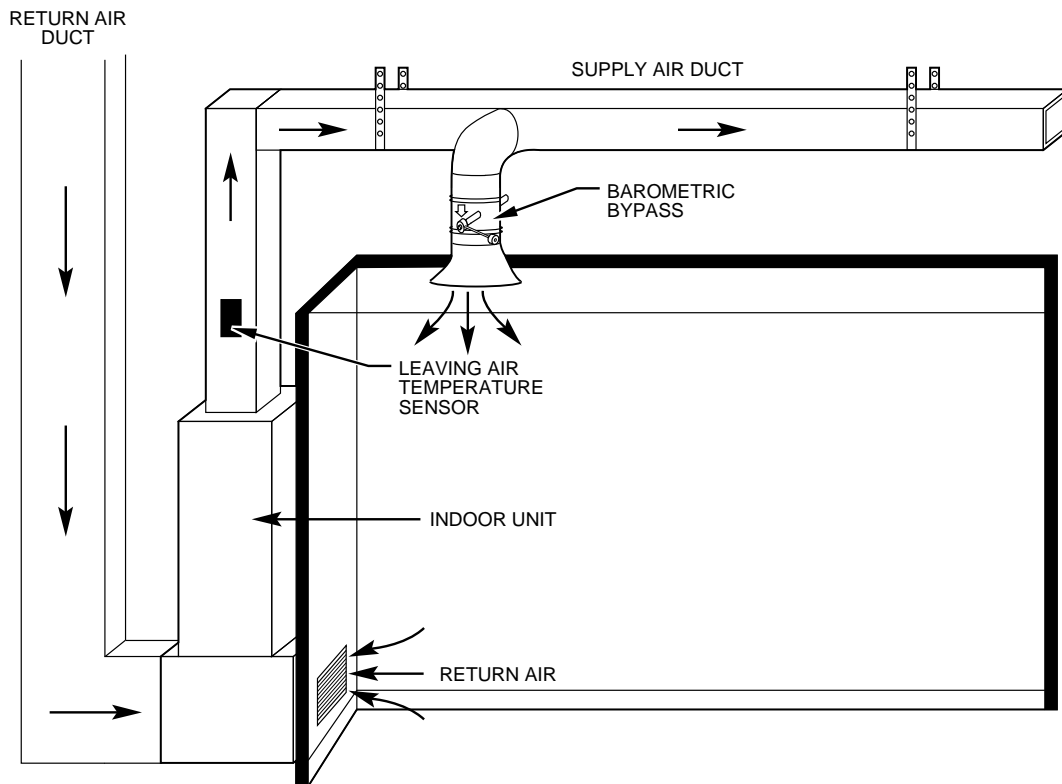

Fig. 3—Dump Zone Installation

A98376

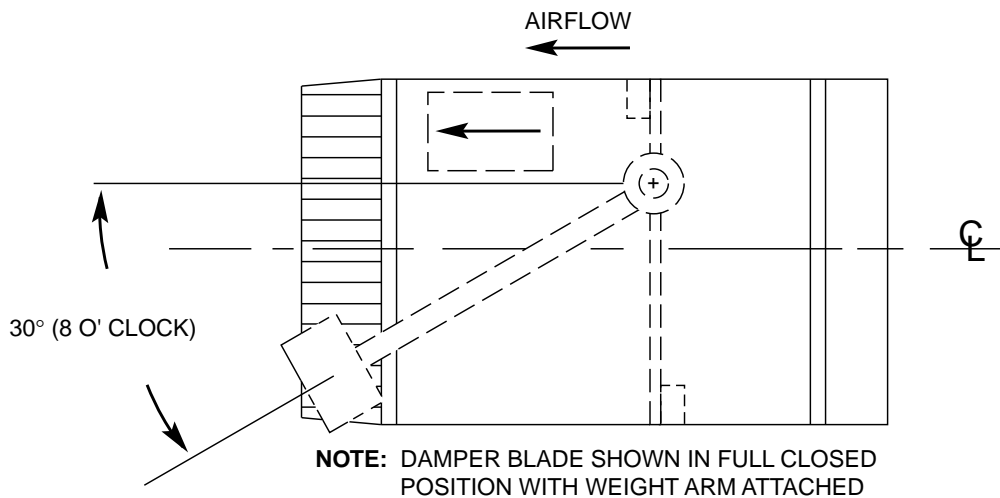
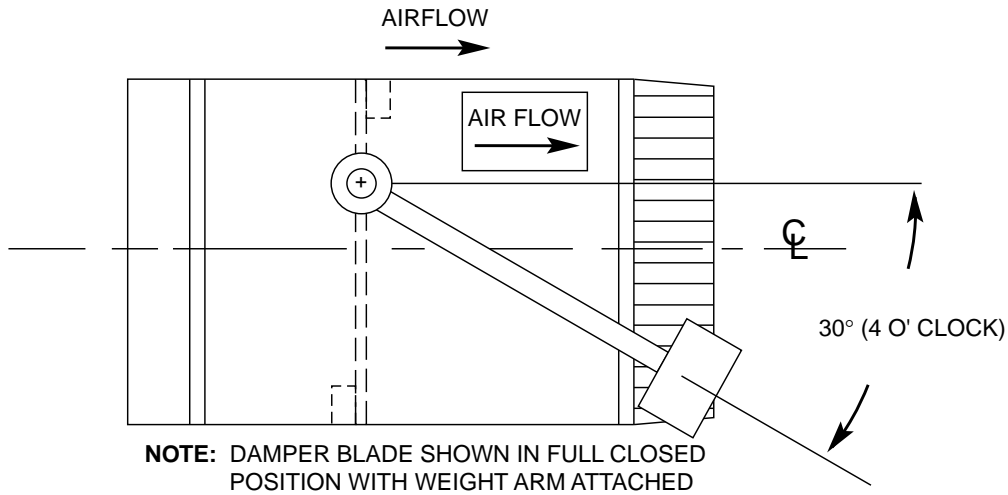

Fig. 4—Damper Arm Assembly Orientation — Counterclockwise Rotation Left

A98479

PROCEDURE 3—MOUNTING THE BYPASS DAMPER

1. The bypass damper may be mounted in any of the 4 positions with airflow up, down, right, or left with the air flowing in the direction of the "airflow" arrow. However, when positioned horizontal (airflow left or right), it must be mounted with the shaft above center. (See Fig. 4—7.)
2. The bypass damper arm assembly may be mounted on either side of the bypass damper.
3. The bypass damper arm and weight(s) (bypass damper arm assembly) are to be positioned 4:00 or 30° below horizontal when the bypass damper is in closed position. The effect of the weight must be to hold the damper closed. Since 4:00 or 30° is 1 hour on the clock, this will require the weight arm assembly to be at 4:00 when the damper opens with counterclockwise rotation or at 8:00 with clockwise rotation to open.
4. Attach the weight arm assembly to the shaft on either side of the bypass damper by sliding the eyelet of the assembly over the shaft end. The hex head on the end of the weight arm may be used to tighten the assembly with a wrench.
5. Tighten the locknut on the weight arm.



A98480

Fig. 5—Damper Arm Assembly Orientation — Counterclockwise Rotation Right

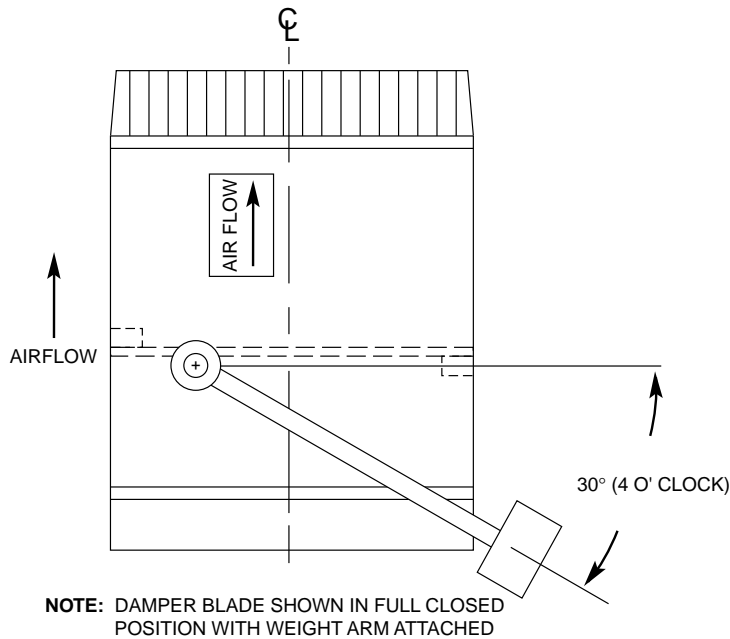

A98481

Fig. 6—Damper Arm Assembly Orientation — Counterclockwise Rotation Up

PROCEDURE 4—ADJUSTING

First, make sure the damper arm is set to the proper angle: 4:00 or 8:00. (See Procedure 2 and 3). Then, manually rotate the bypass damper to make sure there is no binding of its shaft. It must be free to rotate easily even though the weight will hold it solidly closed.

Remember—the bypass damper may never need to open. The highest pressure setting will provide the best performance from the zoning system and will also be best for the equipment. The only reason the damper will need to open is to reduce air noise to an acceptable level.

1. Start with the weight(s) at the end of the arm. This provides at least 0.80 in. of water pressure before the damper begins to open.
2. The equipment blower must be operating in order to adjust the pressure setting.
3. If the zoning system is operational, it may be used to control dampers and equipment while the bypass is being adjusted. See Installer Setup Mode in the zoning Installation Instructions.
4. If the zoning system is not operational, the zone dampers will need to be moved by hand and the equipment blower operating at the highest airflow (cooling airflow). This can usually be done by temporarily connecting R to Y (Y2 if 2-speed). If the system has a variable-speed air handler, be sure the airflow is correct.

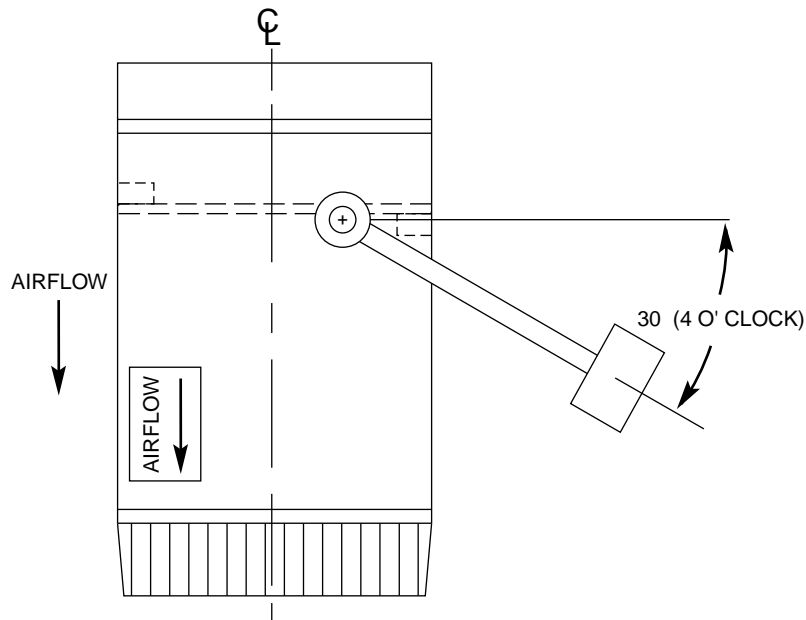

NOTE: DAMPER BLADE SHOWN IN FULL CLOSED POSITION WITH WEIGHT ARM ATTACHED

A98482

Fig. 7—Damper Arm Assembly Orientation — Counterclockwise Rotation Down

5. To determine if adjustment is necessary, first open all zone 1 dampers and close all others. Listen to the air noise from all zone 1 registers. If it is acceptable, do not adjust the bypass. Continue with each zone, opening its dampers only and closing all others. If the noise from a zone is unacceptable, first consider if this zone is likely to be the only zone with demand (all other zones set back). If not, it will likely never be the only zone open, and will be quieter in actual operation and not need any adjustment. If you determine the noise is unacceptable and the damper must be adjusted to a lower pressure setting, follow Step 6.
6. To adjust the bypass, while the blower is running, open the zone damper with the most unacceptable noise and close all other zone dampers. Loosen the weight set screw and reposition the weight nearer the shaft until the bypass just begins to open. Generally, the damper will need to be open a small amount to significantly reduce the air noise. After adjustment, check the noise level again and readjust if necessary. While all other zone dampers are closed, open the other unacceptable noisy zone dampers one by one and adjust the weights if necessary. **In general, try to keep the damper pressure setting as high as possible. Remember you will get the most conditioning into your zone with the bypass fully closed.** If moving the weights all the way to the shaft still does not result in an acceptable noise level, weights may be removed from the arm. This condition is most likely to occur in the downflow orientation.
7. Recheck damper arm alignment and movement. See introductory paragraph of this procedure (Procedure 4).

SERVICE TRAINING

Packaged Service Training programs are an excellent way to increase your knowledge of the equipment discussed in this manual, including:

- Unit Familiarization
- Maintenance
- Installation Overview
- Operating Sequence

A large selection of product, theory, and skills programs is available, using popular video-based formats and materials. All include video and/or slides, plus companion book.

Classroom Service Training plus "hands-on" the products in our labs can mean increased confidence that really pays dividends in faster troubleshooting, fewer callbacks. Course descriptions and schedules are in our catalog.

CALL FOR FREE CATALOG 1-800-644-5544

Packaged Service Training

Classroom Service Training

A94328