

AGAGC9NPS01B Gas Conversion Kit, Natural to Propane Condensing (90%+) Furnaces 40,000 BTUH to 140,000 BTUH Models Only

Installation Instructions

NOTE: Read the entire instruction manual before starting the installation.



A200203

SAFETY CONSIDERATION

WARNING

FIRE, EXPLOSION, ELECTRICAL SHOCK, AND CARBON MONOXIDE POISONING HAZARD

Failure to follow this warning could result in personal injury or death. This conversion kit shall be installed by a qualified service agency in accordance with the manufacturer's instructions and all applicable codes and requirements of the authority having jurisdiction. If the information in these instructions is not followed exactly, a fire, explosion, or production of carbon monoxide could result causing property damage, personal injury, or loss of life. The qualified service agency is responsible for the proper installation of this furnace with this kit. The installation is not proper and complete until the operation of the converted appliance is checked as specified in the manufacturer's instructions supplied with the kit

AVERTISSEMENT

LE FEU, L'EXPLOSION, CHOC ELECTRIQUE, ET MONOXYDE DE CARBONE EMPOISONNER

Cette trousse de conversion doit être installée par un servie d'entretien qualifié, selon les instructions du fabricant et selon toutes les exigences et tous les codes pertinents de l'autorité compétente. Assurezvous de bien suivre les instructions dans cette notice pour réduire au minimum le risque d'incendie, d'explosion ou la production de monoxyde de carbone pouvant causer des dommages matériels, de blessure ou la mort. Le service d'entretien qualifié est responsable de l'installation de cette trousse. L'installation n'est pas adéquate ni complète tant que le bon fonctionnement de l'appareil converti n'a pas été vérifié selon les instructions du fabricant fomies avec la trousse.

Installing and servicing heating equipment can be hazardous due to gas and electrical components. Only trained and qualified personnel should install, repair, or service heating equipment.

Untrained personnel can perform basic maintenance functions such as cleaning and replacing air filters. Trained service personnel must perform all other operations. When working on heating equipment, observe precautions in the literature, on tags, and on labels attached to or shipped with the unit, and other safety precautions that may apply.

Follow all safety codes. In the United States, follow all safety codes including the current edition of the National Fuel Gas Code (NFGC) NFPA No. 54/ANSI Z223.1. In Canada, refer to the current edition of the National Standard of Canada, Natural Gas and Propane Installation Codes (NSCNGPIC), CAN/CSA-B149.1 and .2. Wear safety glasses and work gloves. Have a fire extinguisher available during start-up, adjustment steps, and service calls.

Recognize safety information. This is the safety-alert symbol . When you see this symbol on the furnace and in instructions or manuals, be alert to the potential for personal injury. Understand the signal words DANGER, WARNING, CAUTION and NOTE. The words DANGER, WARNING, and CAUTION are used with the safety alert symbol. DANGER identifies the most serious hazards which will result in severe personal injury or death. WARNING signifies a hazard which could result in personal injury or death. CAUTION is used to identify unsafe practices which may result in minor personal injury or product and property damage. NOTE is used to highlight suggestions which will result in enhanced installation, reliability, or operation.

INTRODUCTION

WARNING

FIRE, EXPLOSION, ELECTRICAL SHOCK AND CARBON MONOXIDE POISONING HAZARD

Failure to follow instructions could result in personal injury, death or property damage.

Improper installation, adjustment, alteration, service, maintenance, or use can cause carbon monoxide poisoning, explosion, fire, electrical shock, or other conditions, which could result in personal injury or death. Consult your distributor or branch for information or assistance. The qualified installer or agency must use only factory-authorized kits or accessories when servicing this product.

WARNING

FIRE, EXPLOSION, ELECTRICAL SHOCK HAZARD

Failure to follow this warning could result in personal injury, death or property damage.

Gas supply **MUST** be shut off before disconnecting electrical power and proceeding with conversion.

! WARNING

ELECTRICAL SHOCK, FIRE OR EXPLOSION HAZARD

Failure to follow this warning could result in personal injury, death or property damage.

Before installing, modifying, or servicing system, main electrical disconnect switch must be in the OFF position and install a lockout tag. There may be more than one disconnect switch. Lock out and tag switch with a suitable warning label. Verify proper operation after servicing.

! CAUTION

UNIT OPERATION HAZARD

Failure to follow this caution may result in unit damage or improper operation.

Do NOT use this kit with furnaces with an input of 26,000 BTUH; the unit will be severely over-fired. This could result in delayed ignition, sooting or premature heat exchanger failure.

This instruction covers the installation of gas conversion kit to convert the following furnaces from natural gas usage to propane gas usage.

NOTE: See appropriate sections for your furnace type.

SINGLE-STAGE GAS VALVE

Condensing Furnaces with 40,000 to 140,000 BTUH (not all models have 140,000 BTUH) gas input rates and a.) Single-Stage, 4-Way Multipoise, Hot Surface Ignition with PSC blower motor or b.) Single-Stage gas valve with Fixed-Speeds Constant Torque ECM (FCT) blower motor .

TWO-STAGE & MODULATING GAS VALVE

Condensing Furnaces with 40,000 through 120,000 Btu/h gas input rate and a.) Modulating gas valve with Variable-Speed Constant Airflow ECM (VCA), b.) Two-Stage gas valve with Variable-Speed Constant Airflow ECM (VCA), or c.) Two-Stage gas valve with Variable-Speed Constant Torque ECM (VCT) blower motor.

Table 1 – Kit Contents

QUANTITY	DESCRIPTION
2	VALVE CVRSN KIT - W/R SPRING 92-0659
1	JUMPER PLUG
7	ORIFICE - 1.25mm
7	MIXER SCREW - CONDENSING FURNACES
1	CONNECTOR - BRASS 1/8" NPT X2"
1	CONNECTOR, SPLC - 3/16"
1	CONNECTOR - 1/4QC ME BOTH ENDS
1	ELBOW, STREET - 150# 1/8" NPT
1	ELBOW, STREET - BRASS 1/8" NPT
1	NIPPLE - HEX (BRASS)
1	SWITCH, PRESSURE
1	TEE - MALE BRANCH (BRASS)
1	TEE, STREET - MALE BRANCH (BRASS)
1	BIT, DRILL 7/64" CONDENSING
1	WIRE ASSY - ORANGE
1	WIRE ASSY - ORANGE
1	LABEL 346161-201 through 346161-205
1	INSTRUCTIONS

DESCRIPTION AND USAGE

This kit is designed for use in the furnaces listed in Table 2 or Table 3, see Table 1 for kit contents. To accommodate many different furnace models, more parts are shipped in kit than will be needed to complete conversion. When installation is complete, discard extra parts.

Table 2 – SINGLE-STAGE CONDENSING FURNACES

MODEL NUMBERS BEGINNING WITH:			
59SP		59SC	
912S	915S	922S	925S
926S	PG95S	PG95ES	PG92ES
(F/G)9MXE	(N/R)92ES	N96VSN	PG92S
R9MS	N9MS	WF(A/H/S)	(N/R)95ES

* Except 26,000 BTUH models.

Table 3 – TWO-STAGE & MODULATING CONDENSING FURNACES

MODEL NUMBERS BEGINNING WITH:			
59MN	59T(N/P)	PG96V	PG95X
987M	986T	925T	926T
(F/G)97C	(F/G)9MA	(F/G)9MV	(F/G)96V
(F/G)9MXT		(F/G)96C	

INSTALLATION

1. Set room thermostat to lowest setting or "OFF"
2. Disconnect power at external disconnect, fuse or circuit breaker.
3. Turn off gas at external shut-off or gas meter.
4. Remove outer doors and set aside.
5. Turn electric switch on gas valve to OFF.

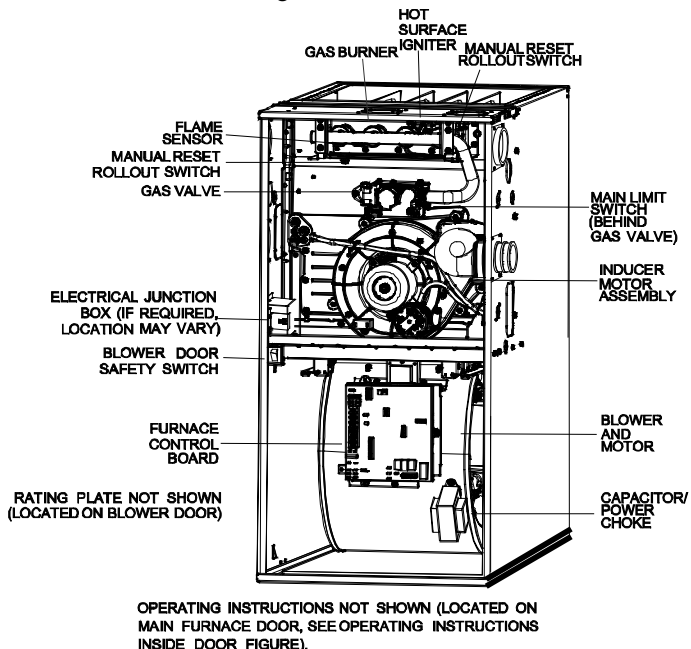

Fig. 1 – Representative Furnace Drawing MANIFOLD/ORIFICE/BURNER REMOVAL

A190014

! CAUTION

UNIT OPERATION HAZARD

Failure to follow this caution may result in unit damage or improper operation.

Label all wires prior to disconnection when servicing controls.

! ATTENTION

D'EQUIPEMENT D'OPERATION

Toute erreur de câblage peut être une source de danger et de panne.
Lors des opérations d'entretien des commandes, étiqueter tous les fils avant de les déconnecter.

NOTE: Use a back-up wrench on the gas valve to prevent the valve from rotating on the manifold or damaging the mounting to the burner box.

1. Disconnect the gas pipe from gas valve and remove pipe from the furnace casing (see Fig. 1)
2. Disconnect the connector harness from gas valve. Disconnect wires from Hot Surface Igniter (HSI) and Flame Sensor.
3. Support the manifold and remove the four (4) screws that secure the manifold assembly to the burner box and set aside.
4. Note the location of the green/yellow wire ground wire for re-assembly later (see Fig. 2)
5. Remove wires from both rollout switches (see Fig. 3)
6. Slide one-piece burner assembly out of slots on sides of burner box (see Fig. 3)
7. Remove the flame sensor from the burner assembly.
8. Remove the orifices from the manifold and discard.

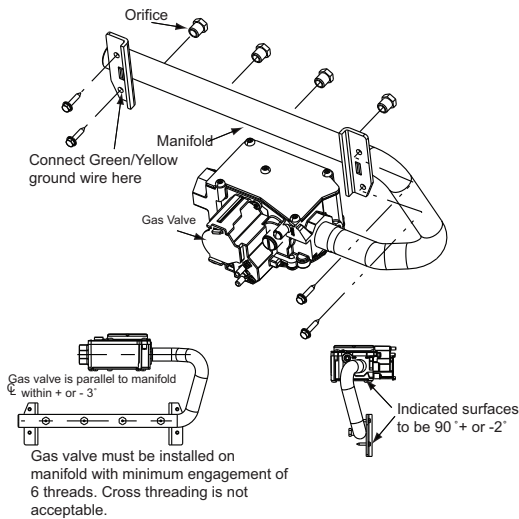

Fig. 2 – Manifold Assembly

A11407

SINGLE-STAGE GAS VALVE

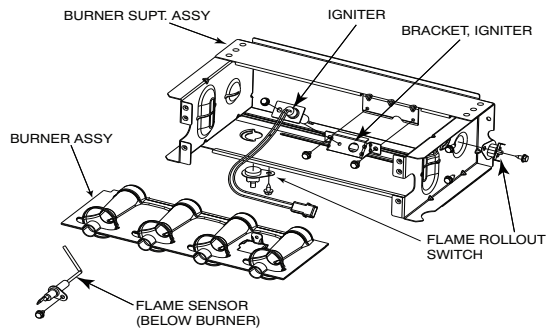

Fig. 3 – Burner Assembly

A11403

ORIFICE SELECTION/DERATE

! CAUTION

UNIT DAMAGE HAZARD

Failure to follow this caution may result in unit damage.
DO NOT re-drill burner orifices. Improper drilling may result in burrs, out-of-round holes, etc. Obtain new orifices if orifice size must be changed (see Fig. 4)

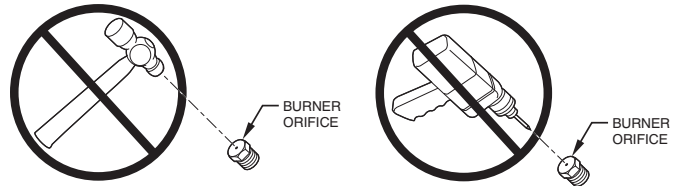

Fig. 4 – Burner Orifice

A96249

Refer to conversion kit rating plate 346161-201 to determine main burner orifice size (see Fig. 5)

Furnace gas input rate on furnace rating plate is for installations at altitudes up to 2000 ft. (610 M).

In the U.S.A.; the input rating for altitudes above 2000 ft. (610 M) must be reduced by 2 percent for each 1000 ft. (305 M) above sea level.

In Canada, the input rating must be derated by 5 percent for altitudes of 2000 ft. to 4500 ft. (610 M to 1372 M) above sea level.

The Conversion Kit Rating Plate accounts for high altitude derate.

CONVERSION KIT RATING PLATE

THIS APPLIANCE HAS BEEN CONVERTED TO USE PROPANE GAS FOR FUEL. REFER TO KIT INSTRUCTIONS FOR CONVERSION PROCEDURES. USE PARTS SUPPLIED BY MANUFACTURER AND INSTALLED BY QUALIFIED PERSONNEL. SEE EXISTING RATING PLATE FOR APPLIANCE MODEL NO. AND INPUT RATING.

NOTE: Furnace gas input rate on rating plate is for installations up to 2000 ft. (610m) above sea level. In U.S.A. the input rating for altitudes above 2000 ft. (610m) must be derated by 2% for each 1000 ft. (305m) above sea level. In Canada the input rating must be derated by 5% for altitudes of 2000 ft. (610m) to 4500 ft. (1372m) above sea level.

KIT NO.: AGAGC9NPS01B (SUPERSEDES: KGBNP50011SP, KGANP51012SP, KGCNP5201VSP, NAHD00901LP, NAHB01001LP, AGAGC9NPS01A) FUEL USED: PROPANE GAS INLET PRESSURE (min - max): 12.0 - 13.6 in. wc

APPLIANCE MODELS Δ	Orifice No.	ALTITUDE OF INSTALLATION (FT. ABOVE SEA LEVEL) U.S.A. *									
		0 to 2000	2001 * to 3000	3001 to 4000	4001 to 5000	5001 to 6000	6001 to 7000	7001 to 8000	8001 to 9000	9001 to 10000	
59S(P/C/E), 91(2/5)S, 92(2/5/6)S, PG9(2/5)S, PG9(2/5)ES, (F/G)9MXE, F9MES, (N/R)9MS, (N/R)9SES, (N/R)9ZES, WF(A/H/S), (N/R)96VS		1.25mm	1.25mm	1.25mm	1.25mm	1.25mm	1.25mm	1.25mm	1.25mm	1.25mm	1.25mm
		11.0	11.0	11.0	11.0	11.0	11.0	11.0	11.0	11.0	11.0

* For Canadian Installations from 2000 to 4500 ft. (610m to 1373m) use U.S.A. column 2001 to 3000 ft. (611m to 914m).
 Δ THIS KIT IS FOR 40K THROUGH 140K INPUT MODELS ONLY

346161-201 REV A

A200206

PLAQUE SIGNALÉTIQUE DE LA TROUSSE DE CONVERSION

CET APPAREIL A ÉTÉ CONVERTI POUR UNE COMBUSTION AU GAZ PROPANE. SE RÉFÉRER AUX INSTRUCTIONS DE L'ÉQUIPEMENT POUR LES PROCÉDURES DE CONVERSION. N'UTILISEZ QUE DES PIÈCES FOURNIES PAR LE MANUFACTURIER ET INSTALLÉES PAR DU PERSONNEL QUALIFIÉ. VOIR LA PLAQUE SIGNALÉTIQUE EXISTANTE POUR LE MODÈLE D'APPAREIL ET LA CONSOMMATION.

REMARQUE: Le débit d'entrée du gaz de la fournaise indiqué sur la plaque signalétique s'applique aux installations jusqu'à 610m (2000 pieds) au-dessus du niveau de la mer. Aux États-Unis, le débit d'entrée pour les altitudes au-dessus de 610m (2000 pieds) doit être réduit de 2% pour chaque 305m (1000 pieds) au-dessus du niveau. Au Canada, le débit d'entrée doit être réduit par 5% pour les altitudes de 2000 pieds à 4500 pieds au-dessus du niveau de la mer.

KIT NO.: AGAGC9NPS01B (SUPPLANT: KGBNP50011SP, KGANP51012SP, KGCNP5201VSP, NAHD00901LP, NAHB01001LP, AGAGC9NPS01A) COMBUSTIBLE: GAZ PROPANE PRESSION D'ENTRÉE (min - max): 12.0 - 13.6 po COLONNE D'EAU

APPROUVÉ POUR LES MODÈLES: Δ	N° Orifice	ALTITUDE DE L'INSTALLATION (PI AU-DESSUS DU NIVEAU DE LA MER) É.U. *								
		0 to 2000	2001 * to 3000	3001 to 4000	4001 to 5000	5001 to 6000	6001 to 7000	7001 to 8000	8001 to 9000	9001 to 10000
59S(P/C/E), 91(2/5)S, 92(2/5/6)S, PG9(2/5)S, PG9(2/5)ES, (F/G)9MXE, F9MES, (N/R)9MS, (N/R)9SES, (N/R)92ES, WF(A/H/S), (N/R)96VS		1.25mm	1.25mm	1.25mm	1.25mm	1.25mm	1.25mm	1.25mm	1.25mm	1.25mm
		Pression Collecteur								
		11.0	11.0	11.0	11.0	11.0	11.0	11.0	11.0	11.0

* Pour les installations au Canada entre 610m et 1373m (2000 to 4500 ft) utiliser la colonne à 611m et 914m (2001 to 3000 ft) des É.U.
 Δ CE KIT EST SEULEMENT POUR LES MODÈLES D'ENTRÉE DE 40K À 140K

346161-204 REV.A

A200208

TWO-STAGE GAS VALVE

CONVERSION KIT RATING PLATE

THIS APPLIANCE HAS BEEN CONVERTED TO USE PROPANE GAS FOR FUEL. REFER TO KIT INSTRUCTIONS FOR CONVERSION PROCEDURES. USE PARTS SUPPLIED BY MANUFACTURER AND INSTALLED BY QUALIFIED PERSONNEL. SEE EXISTING RATING PLATE FOR APPLIANCE MODEL NO. AND INPUT RATING.

NOTE: Furnace gas input rate on rating plate is for installations up to 2000 ft. (610m) above sea level. In U.S.A. the input rating for altitudes above 2000 ft. (610m) must be derated by 2% for each 1000 ft. (305m) above sea level. In Canada the input rating must be derated by 5% for altitudes of 2000 ft. (610m) to 4500 ft. (1372m) above sea level.

KIT NO.: AGAGC9NPS01B (SUPERSEDES: KGBNP50011SP, KGANP51012SP, KGCNP5201VSP, NAHD00901LP, NAHB01001LP, AGAGC9NPS01A) FUEL USED: PROPANE GAS INLET PRESSURE (min - max): 12.0 - 13.6 in. wc

APPLIANCE MODELS Δ	Orifice No.	ALTITUDE OF INSTALLATION (FT. ABOVE SEA LEVEL) U.S.A. *								
		0 to 2000	2001 * to 3000	3001 to 4000	4001 to 5000	5001 to 6000	6001 to 7000	7001 to 8000	8001 to 9000	9001 to 10000
59T(N/P), 986T, 92(5/6)T, PG96V, PG95X, (F/G)9MV, (F/G)9MXT, (F/G)96C, (F/G)96V		1.25mm	1.25mm	1.25mm	1.25mm	1.25mm	1.25mm	1.25mm	1.25mm	1.25mm
		Manifold Pressure								
	HIGH	11.0	11.0	11.0	11.0	11.0	11.0	11.0	11.0	11.0
	LOW	5.8	5.5	5.5	5.5	5.4	5.4	5.4	5.3	5.3

* For Canadian Installations from 2000 to 4500 ft. (610m to 1373m) use U.S.A. column 2001 to 3000 ft. (611m to 914m).
 Δ THIS KIT IS FOR 40K THROUGH 140K INPUT MODELS ONLY

346161-204 REV.A

A200212

PLAQUE SIGNALÉTIQUE DE LA TROUSSE DE CONVERSION

CET APPAREIL A ÉTÉ CONVERTI POUR UNE COMBUSTION AU GAZ PROPANE. SE RÉFÉRER AUX INSTRUCTIONS DE L'ÉQUIPEMENT POUR LES PROCÉDURES DE CONVERSION. N'UTILISEZ QUE DES PIÈCES FOURNIES PAR LE MANUFACTURIER ET INSTALLÉES PAR DU PERSONNEL QUALIFIÉ. VOIR LA PLAQUE SIGNALÉTIQUE EXISTANTE POUR LE MODÈLE D'APPAREIL ET LA CONSOMMATION.

REMARQUE: Le débit d'entrée du gaz de la fournaise indiqué sur la plaque signalétique s'applique aux installations jusqu'à 610m (2000 pieds) au-dessus du niveau de la mer. Aux États-Unis, le débit d'entrée pour les altitudes au-dessus de 610m (2000 pieds) doit être réduit de 2% pour chaque 305m (1000 pieds) au-dessus du niveau. Au Canada, le débit d'entrée doit être réduit par 5% pour les altitudes de 2000 pieds à 4500 pieds au-dessus du niveau de la mer.

KIT NO.: AGAGC9NPS01B (SUPPLANT: KGBNP50011SP, KGANP51012SP, KGCNP5201VSP, NAHD00901LP, NAHB01001LP, AGAGC9NPS01A) COMBUSTIBLE: GAZ PROPANE PRESSION D'ENTRÉE (min - max): 12.0 - 13.6 po COLONNE D'EAU

APPROUVÉ POUR LES MODÈLES: Δ	N° Orifice	ALTITUDE DE L'INSTALLATION (PI AU-DESSUS DU NIVEAU DE LA MER) É.U. *								
		0 to 2000	2001 * to 3000	3001 to 4000	4001 to 5000	5001 to 6000	6001 to 7000	7001 to 8000	8001 to 9000	9001 to 10000
59T(N/P), 986T, 92(5/6)T, PG96V, PG95X, (F/G)9MV, (F/G)9MXT, (F/G)96C, (F/G)96V		1.25mm	1.25mm	1.25mm	1.25mm	1.25mm	1.25mm	1.25mm	1.25mm	1.25mm
		Pression Collecteur								
	HIGH	11.0	11.0	11.0	11.0	11.0	11.0	11.0	11.0	11.0
	LOW	5.8	5.5	5.5	5.5	5.4	5.4	5.4	5.3	5.3

* Pour les installations au Canada entre 610m et 1373m (2000 to 4500 ft) utiliser la colonne à 611m et 914m (2001 to 3000 ft) des É.U.
 Δ CE KIT EST SEULEMENT POUR LES MODÈLES D'ENTRÉE DE 40K À 140K

346161-209 REV.A

A200213

MODULATING GAS VALVE

CONVERSION KIT RATING PLATE

THIS APPLIANCE HAS BEEN CONVERTED TO USE PROPANE GAS FOR FUEL. REFER TO KIT INSTRUCTIONS FOR CONVERSION PROCEDURES. USE PARTS SUPPLIED BY MANUFACTURER AND INSTALLED BY QUALIFIED PERSONNEL. SEE EXISTING RATING PLATE FOR APPLIANCE MODEL NO. AND INPUT RATING.

NOTE: Furnace gas input rate on rating plate is for installations up to 2000 ft. (610m) above sea level. In U.S.A. the input rating for altitudes above 2000 ft. (610m) must be derated by 2% for each 1000 ft. (305m) above sea level. In Canada the input rating must be derated by 5% for altitudes of 2000 ft. (610m) to 4500 ft. (1372m) above sea level.

KIT NO.: AGAGC9NPS01B (SUPERSEDES: KGBNP50011SP, KGANP51012SP, KGCNP5201VSP, NAHD00901LP, NAHB01001LP, AGAGC9NPS01A) FUEL USED: PROPANE GAS INLET PRESSURE (min - max): 12.0 - 13.6 in. wc

APPLIANCE MODELS Δ	Orifice No.	ALTITUDE OF INSTALLATION (FT. ABOVE SEA LEVEL) U.S.A. *								
		0 to 2000	2001 * to 3000	3001 to 4000	4001 to 5000	5001 to 6000	6001 to 7000	7001 to 8000	8001 to 9000	9001 to 10000
59MN, 987M, (F/G)9MA, (F/G)97C		1.25mm	1.25mm	1.25mm	1.25mm	1.25mm	1.25mm	1.25mm	1.25mm	1.25mm
		Manifold Pressure								
	MAX	11.0	11.0	11.0	11.0	11.0	11.0	11.0	11.0	11.0
	INT	5.8	5.5	5.5	5.5	5.4	5.4	5.4	5.3	5.3
	MIN	2.2	2.1	2.1	2.1	2.1	2.0	2.0	2.0	2.0

* For Canadian Installations from 2000 to 4500 ft. (610m to 1373m) use U.S.A. column 2001 to 3000 ft. (611m to 914m).
 Δ THIS KIT IS FOR 40K THROUGH 140K INPUT MODELS ONLY

346161-206 REV.A

A200210

PLAQUE SIGNALÉTIQUE DE LA TROUSSE DE CONVERSION

CET APPAREIL A ÉTÉ CONVERTI POUR UNE COMBUSTION AU GAZ PROPANE. SE RÉFÉRER AUX INSTRUCTIONS DE L'ÉQUIPEMENT POUR LES PROCÉDURES DE CONVERSION. N'UTILISEZ QUE DES PIÈCES FOURNIES PAR LE MANUFACTURIER ET INSTALLÉES PAR DU PERSONNEL QUALIFIÉ. VOIR LA PLAQUE SIGNALÉTIQUE EXISTANTE POUR LE MODÈLE D'APPAREIL ET LA CONSOMMATION.

REMARQUE: Le débit d'entrée du gaz de la fournaise indiqué sur la plaque signalétique s'applique aux installations jusqu'à 610m (2000 pieds) au-dessus du niveau de la mer. Aux États-Unis, le débit d'entrée pour les altitudes au-dessus de 610m (2000 pieds) doit être réduit de 2% pour chaque 305m (1000 pieds) au-dessus du niveau. Au Canada, le débit d'entrée doit être réduit par 5% pour les altitudes de 2000 pieds à 4500 pieds au-dessus du niveau de la mer.

KIT NO.: AGAGC9NPS01B (SUPPLANT: KGBNP50011SP, KGANP51012SP, KGCPNS201VSP, NAHD00901LP, NAHB01001LP, AGAGC9NPS01A) COMBUSTIBLE: GAZ PROPANE PRESSION D'ENTRÉE (min - max): 12.0 - 13.6 po COLONNE D'EAU

APPROUVÉ POUR LES MODÈLES: Δ	Orifice No.	ALTITUDE DE L'INSTALLATION (PI AU-DESSUS DU NIVEAU DE LA MER) É.U. *								
		0 to 2000	2001 * to 3000	3001 to 4000	4001 to 5000	5001 to 6000	6001 to 7000	7001 to 8000	8001 to 9000	9001 to 10000
59MN, 987M, (F/G)9MA, (F/G)97C		1.25mm	1.25mm	1.25mm	1.25mm	1.25mm	1.25mm	1.25mm	1.25mm	1.25mm
	Pression Collecteur									
	MAX	11.0	11.0	11.0	11.0	11.0	11.0	11.0	11.0	11.0
	INT	5.8	5.5	5.5	5.5	5.4	5.4	5.4	5.3	5.3
	MIN	2.2	2.1	2.1	2.1	2.1	2.0	2.0	2.0	2.0

* Pour les installations au Canada entre 610m et 1373m (2000 to 4500 ft) utiliser la colonne à 611m et 914m (2001 to 3000 ft) des É.U.
 Δ CE KIT EST SEULEMENT POUR LES MODÈLES D'ENTRÉE DE 40K À 140K.



346161-207 REV.A

Fig. 5 – Conversion Kit Rating Plate (40,000 BTUH to 140,000 BTUH ONLY)

INSTALL ORIFICES

1. Install main burner orifices. Do not use PTFE thread-seal tape. Finger-tighten orifices at least one full turn to prevent cross-threading, then tighten with wrench.
2. There are enough orifices in each kit for largest furnace. Discard extra orifices.

NOTE: DO NOT reinstall the manifold at this time.

INSTALL MIXER SCREWS

NOTE: “REQUIRED FOR THE CONVERSION OF CONDENSING GAS FURNACES TO PROPANE GAS”

1. See Fig. 6 to verify you have the correct set of mixer screws.
2. Locate the dimple on each burner venturi tube.
3. If you cannot locate the dimple, refer to Fig. 7 for location of the mixer screw.
4. Drill a 7/64-in (2.8 mm) hole (supplied in kit) in each dimple.
5. Install a mixer screw in each drilled hole drilling as straight as possible (i.e. in the center of the gas flow stream as well as perpendicular to the gas flow stream).
6. The screw head should be flush with the top of the burner venturi.

337932-701

PART #	CONTAINS: DESCRIPTION	QTY
328456-402	BIT, DRILL	1
FAJ5812B	SCREW	7

REQUIRED FOR CONVERSION OF CONDENSING GAS FURNACE TO PROPANE GAS.

Fig. 6 – Gas Conversion Kit

A11294

REINSTALL BURNER ASSEMBLY

To reinstall burner assembly:

1. Attach flame sensor to burner assembly.
2. Insert one-piece burner in slot on sides of burner box and slide burner back in place.
3. Reattach HSI wires to HSI.
4. Verify igniter to burner alignment (see Fig. 8 & Fig. 9)

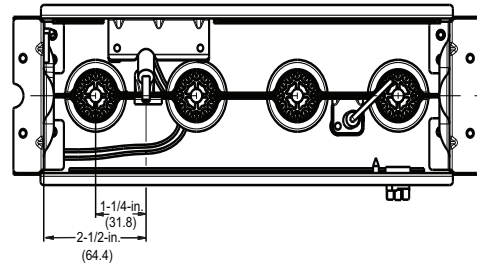

Fig. 8 – Igniter Position - Back View

A11405

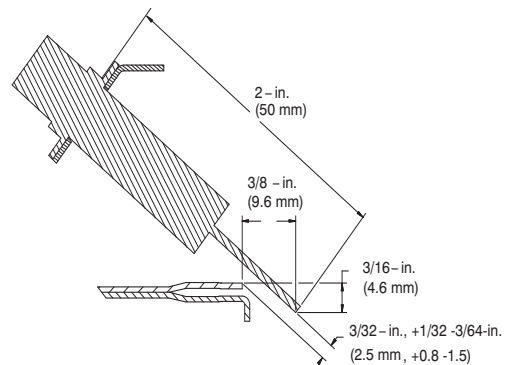

Fig. 9 – Igniter Position - Side View

A12392

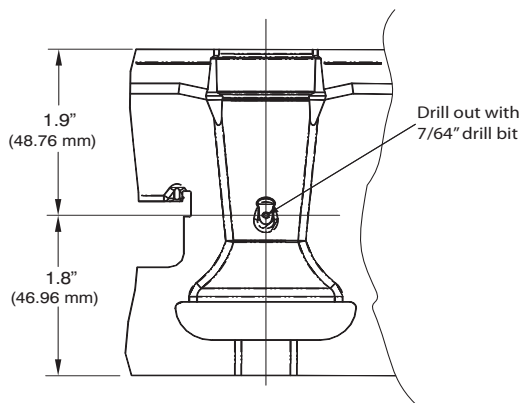

Fig. 7 – Mixer Screw Location

A11460

CONVERT GAS VALVE

! CAUTION

UNIT OPERATION HAZARD

Failure to follow this caution may result in unit damage or improper operation.

Do NOT use this kit if the gas valve has a green label (26,000 BTUH model) on it shown in Fig. 10 or Fig. 11. The 26,000 BTUH model uses a different conversion kit available from your distributor.

The 26,000 BTUH model uses a different conversion kit. Refer to Product Specification for the correct conversion kit, available from your distributor.

NOTE: Do not use this kit if the gas valve in Fig. 10 or Fig. 11 has a green label on top of the valve. The green label on the gas valve is a special low capacity gas valve. Refer to Specification Sheet for the correct conversion kit.

! CAUTION

UNIT DAMAGE HAZARD

Failure to follow this caution may result in unit damage

The gas valve must be converted and pre-adjusted before operating on propane gas. If not converted and pre-adjusted, sooting and corrosion will occur leading to early heat exchanger failure.

! WARNING

FIRE, EXPLOSION, ELECTRICAL SHOCK HAZARD

Failure to follow this warning could result in personal injury, death or property damage.

Gas supply **MUST** be shut off before disconnecting electrical power and proceeding with conversion.

! WARNING

ELECTRICAL SHOCK, FIRE OR EXPLOSION HAZARD

Failure to follow this warning could result in personal injury, death or property damage.

Before installing, modifying, or servicing system, main electrical disconnect switch must be in the OFF position and install a lockout tag. There may be more than one disconnect switch. Lock out and tag switch with a suitable warning label. Verify proper operation after servicing.

Single Stage Gas Valve

1. Refer to Fig. 10 and Fig. 11. Verify the gas valve has a white label with black lettering on top of the operator.
2. Be sure gas and electrical supplies to furnace are off.
3. Remove caps that conceal adjustment screws for the gas-valve regulators (see Fig. 10 and Fig. 11)
4. Remove the regulator adjustment screw.
5. Remove the regulator springs (silver).
6. Install the propane gas regulator springs (white).
7. Install the regulator adjustment screws.
8. Turn the adjusting screw clockwise (in) 8.5 full turns. This will increase the manifold pressure closer to the propane set point (see Fig. 10 and Fig. 11)

9. Do not install regulator seal caps at this time.

NOTE: If there is a GREEN LABEL on gas valve, ensure the correct conversion kit is ordered for the 26K BTUH models.

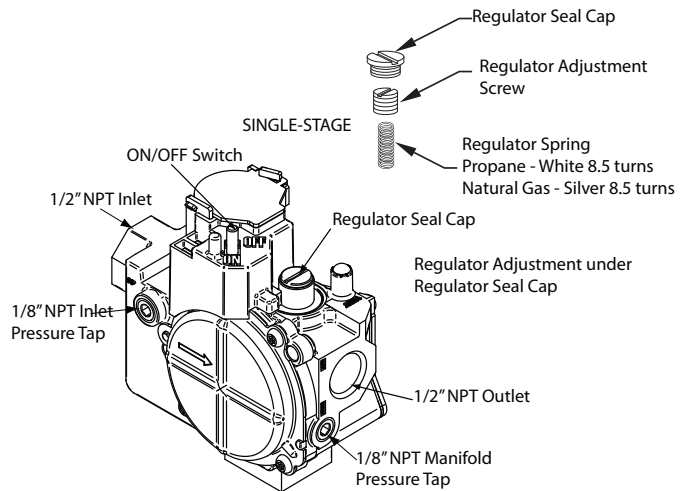

NOTE: Remove the natural gas regulator spring (silver)
Install the propane regulator spring (white)

Fig. 10 – Gas Valve (Single Stage) without Tower Pressure Ports A13048

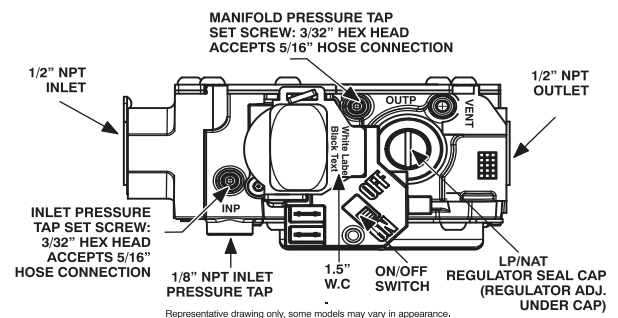

A170118B

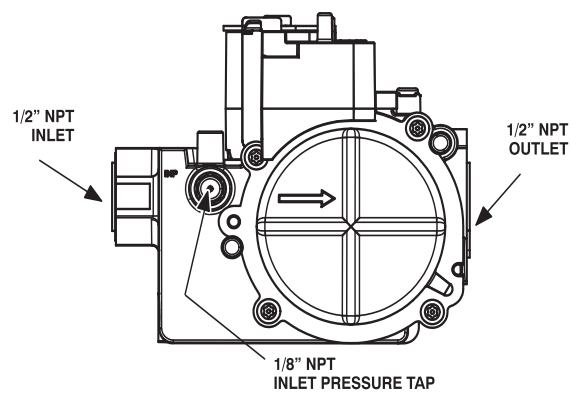

Representative drawing only, some models may vary in appearance.

Fig. 11 – Gas Valve (Single Stage) with Tower Pressure Ports A170133

Two Stage Gas Valve

Refer to Fig. 12 and Fig. 13.

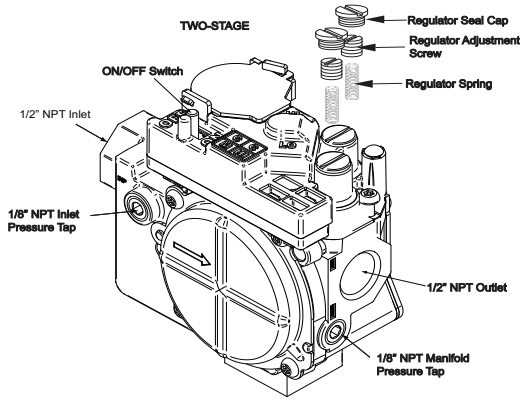
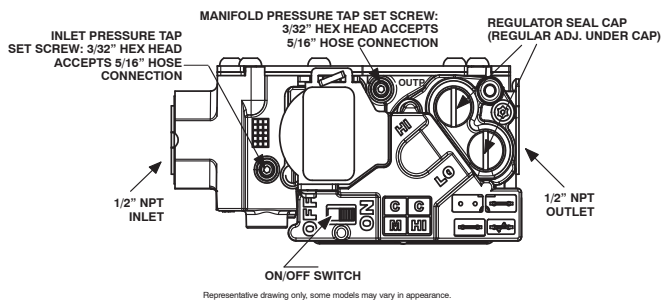

Fig. 12 – Automatic Gas Valve (Two-Stage) without Tower Pressure Ports A11472



A170117

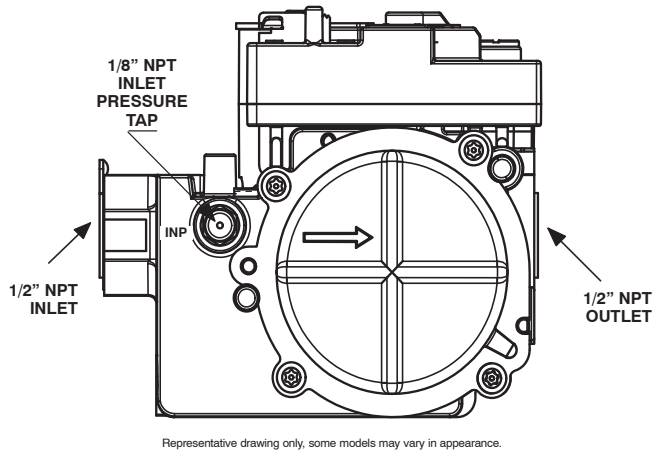

Fig. 13 – Automatic Gas Valve (Two-Stage) with Tower Pressure Ports A170132

1. Remove caps that conceal adjustment screws for high heat and low heat gas-valve regulators (see Fig. 12 and Fig. 13)
2. Remove the high heat and low heat regulator adjustment screws.
3. Remove the high heat and low heat regulator springs (silver).
4. Install the high heat and low heat propane gas regulator springs (white).
5. Install the high heat and low heat regulator adjustment screws.
6. Turn high heat stage adjusting screw clockwise (in) 13.5 full turns. This will increase the manifold pressure closer to the propane set point.

7. Turn low heat stage adjusting screw clockwise (in) 9.5 full turns. This will increase the manifold pressure closer to the propane low heat set point.
8. Do not install regulator seal caps at this time.

Modulating Gas Valve

Refer to Fig. 14 through Fig. 16.

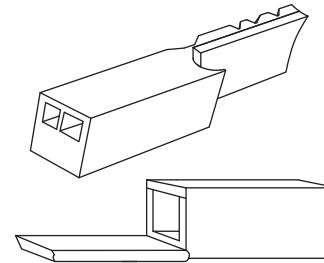

Fig. 14 – Propane Jumper A11373

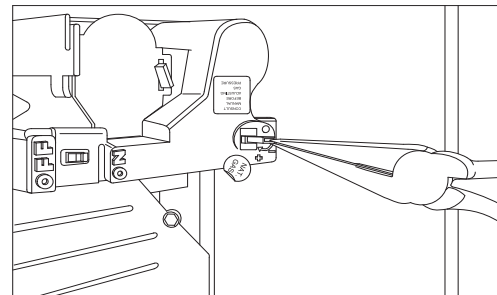
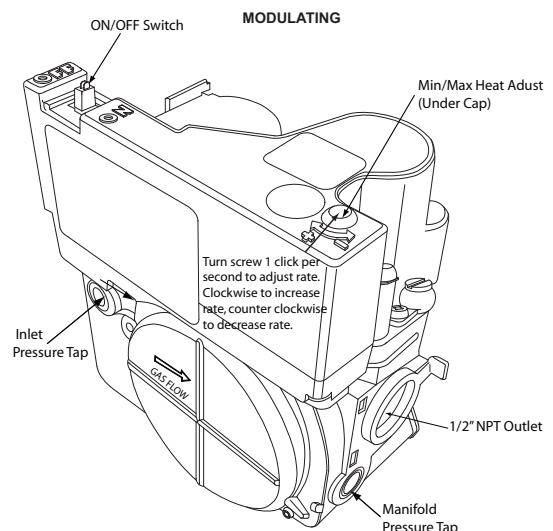

Fig. 15 – Installing Propane Jumper A11375

NOTE: The Propane jumper for the modulating gas valve is very small. Needle-nose pliers are required to insert the jumper into the valve. If the jumper is not installed, the valve will not operate properly on propane.

1. Locate the round “NAT GAS” sticker on the top of the gas valve.
2. Peel the sticker off and discard.
3. Note the small square opening in the top of the gas valve.
4. Note the two jumper pins inside the modulating gas valve.
5. Remove the small black plastic propane jumper from the envelope.
6. Use needle-nosed pliers to hold the jumper by the tab on the end.
7. Insert the jumper on the pins inside the gas valve.
8. Cover the opening in the gas valve with the label marked “LP GAS”



A10496

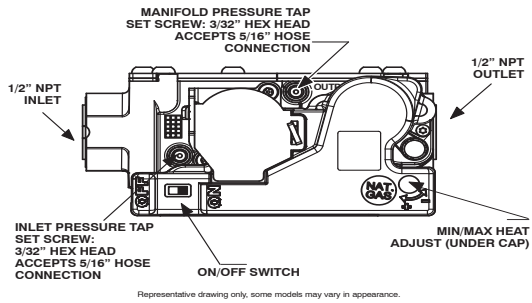

A170116

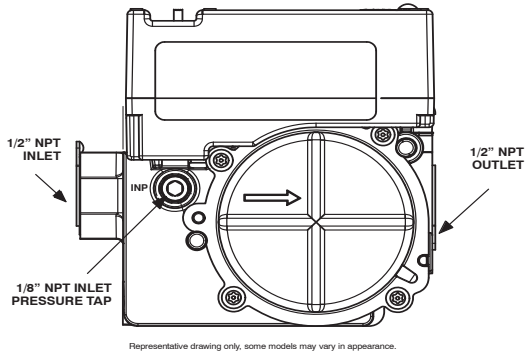

A170131

Fig. 16 – Automatic Control Valve (Modulating) without Tower Pressure Ports

INSTALL LOW GAS PRESSURE SWITCH

NOTE: Install the Low Gas Pressure Switch before installing the manifold on the burner assembly.

There are two ways to mount the Low Gas Pressure Switch.

All 14 3/16-in Casings or Vent Passed Between Inducer Assembly and Burner Assembly

If the vent pipe passes between the inducer and burner assembly, or the furnace is a 14 3/16-in. wide casing. The switch may be installed as shown in Fig. 17:

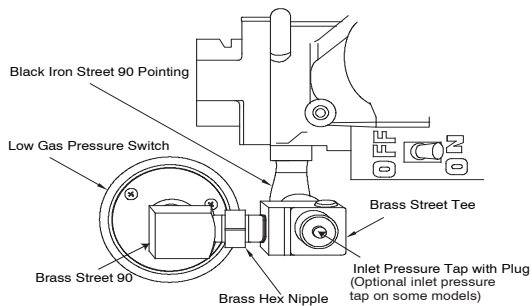

A170141

Fig. 17 – LGPS for 14-3/16 Casing or when vent passes between inducer and burner assembly

1. Remove the 1/8-in. (3 mm) NPT pipe plug from the gas valve inlet pressure tap.

NOTE: Use pipe dope approved for use with Propane Gas.

NOTE: Tighten all fittings and the Low Gas Pressure Switch with a small wrench. Do not over-tighten, check for gas leaks after gas supply has been turned on.

! WARNING

FIRE OR EXPLOSION HAZARD

Failure to follow this warning could result in personal injury, death, and/or property damage.

Never test for gas leaks with an open flame. Use a commercially available soap solution made specifically for the detection of leaks to check all connections. A fire or explosion may result causing property damage, personal injury or loss of life.

! AVERTISSEMENT

RISQUE D'EXPLOSION ET D'INCENDIE

Le non-respect des avertissements de sécurité pourrait d'entraîner des blessures graves, la mort ou des dommages matériels.

Ne jamais utiliser une flamme nue pour vérifier la présence des fuites de gaz. Pour la vérification de tous les joints, utiliser plutôt une solution savonneuse commerciale fabriquée spécifiquement pour la détection des fuites de gaz. Un incendie ou une explosion peut entraîner des dommages matériels, des blessures ou la mort.

2. Apply pipe dope sparingly to the male threads of the 1/8-in. (3 mm) black iron street elbow. Install the street elbow into the gas valve inlet pressure tap. One end of the opening of the street elbow should be parallel with the inlet boss on the gas valve. The other opening should be pointing toward you.
3. Apply pipe dope sparingly to the male threads of the 1/8-in. (3 mm) brass street tee. Install the male end of the street tee as shown in Fig. 17. One opening on the street tee should face you. The other opening should be parallel with the inlet of the gas valve.
4. Apply pipe dope sparingly to the male threads of the 1/8-in. (3 mm) brass hex nipple. Install the hex nipple into the open end of the brass street tee (see Fig. 17) The hex nipple should be parallel with the boss on the gas valve.
5. Install the open end of the brass street elbow on the end of the hex nipple. Tighten the street elbow so the male threads of the elbow point away from you.
6. Apply pipe dope sparingly to the male threads of the 1/8-in. (3 mm) brass street elbow. Install the Low Gas Pressure Switch on the male threads of the 1/8-in. (3 mm) street elbow. Tighten switch at hex fitting at base of switch. Do not use switch body to tighten switch. Do not over-tighten switch.
7. The remaining opening on the brass street tee is the new gas valve inlet pressure tap (optional on some models). Apply pipe dope to inlet pressure plug from gas valve and install in open end of brass street tee.
8. Check all fittings for leaks after gas supply has been turned on.

Casings Wider Than 14 3/16-in/Vent Does Not Pass Between Inducer and Burner Assembly

If the vent pipe does not pass between the inducer and burner assembly, or the furnace is wider than a 14 3/16-in. wide casing. The switch may be installed as shown in Fig. 18):

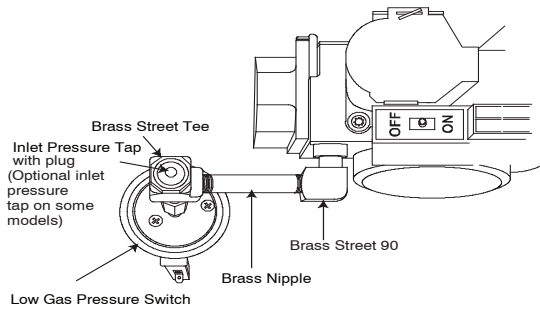

Fig. 18 – LGPS for casing wider than 14-3/16 and vent does not pass between inducer and burner assembly

A170142

1. Remove the 1/8-in. (3 mm) NPT pipe plug from the gas valve inlet pressure tap.

NOTE: Use pipe dope approved for use with Propane Gas.

NOTE: Tighten all fittings and the Low Gas Pressure Switch with a small wrench. Do not over-tighten, check for gas leaks after gas supply has been turned on.

2. Apply pipe dope sparingly to the male threads of the brass street elbow.
3. Install the brass street elbow in inlet pressure tap of the gas valve
4. Tighten the brass street elbow with a small wrench so the outlet faces to your left.
5. Apply pipe dope sparingly to the male threads of the 2-in. brass nipple.
6. Install the brass nipple in the outlet of the brass street elbow.
7. Locate the brass street tee in the kit. Orient the tee so the male threads on the tee face away from you and the female threads face point to the male threads of the 2-in brass nipple.
8. With a small back-up wrench on the brass street elbow, tighten the brass street tee with a small wrench until the fittings are tight and the male portion of the threads point away from you.
9. Apply pipe dope sparingly to the male threads of the 1/8-in. brass street elbow. Install the Low Gas Pressure Switch on the male threads of the street elbow. Tighten switch at hex fitting at base of switch. Do not use switch body to tighten switch. Do not over-tighten switch.
10. The remaining opening on the brass street tee is the new gas valve inlet pressure tap (optional on some models). Apply pipe dope to inlet pressure plug from gas valve and install in open end of brass street tee.
11. Check all fittings for leaks after gas supply has been turned on.

INSTALL LOW GAS PRESSURE SWITCH WIRES

1. Locate the orange wire in the kit with an insulated straight female spade terminal and an insulated straight male terminal on the other end.
2. Connect the female terminal to a terminal on the Low Gas Pressure Switch.
3. Locate the orange wire in kit with an insulated straight female spade terminal and an insulated female flag terminal on the other end.
4. Connect both straight female terminals of the orange wires to the terminals on the Low Gas Pressure Switch.

INSTALL MANIFOLD

1. Refer to Fig. 2 and Fig. 3.
2. Align the orifices in the manifold assembly with the support rings on the end of the burner.

3. Insert the orifices in the support rings of the burners. Manifold mounting tabs should fit flush against the burner box.

NOTE: If manifold does not fit flush against the burner box, the burners are not fully seated forward. Remove the manifold and check burner positioning in the burner box assembly.

4. Attach the green/yellow wire and ground terminal to one of the manifold mounting screws (see Fig. 2)
5. Install the remaining manifold mounting screws.
6. Connect the wires to the flame sensor and hot surface igniter.
7. Connect the connector harness to gas valve.

NOTE: Use only propane-resistant pipe dope. Do not use PTFE thread-seal tape.

8. Insert the gas pipe through the grommet in the casing. Apply a thin layer of pipe dope to the threads of the pipe and thread the pipe by into the gas valve.

NOTE: Use a back-up wrench on the gas valve to prevent the valve from rotating on the manifold or damaging the mounting to the burner box.

9. With a back-up wrench on the inlet boss of the gas valve, finish tightening the gas pipe to the gas valve.
10. Turn gas on at electric switch on gas valve.

MODIFY PRESSURE SWITCH WIRING

! CAUTION

UNIT OPERATION HAZARD

Failure to follow this caution may result in unit damage or improper operation.

Label all wires prior to disconnection when servicing controls.

! ATTENTION

D'ÉQUIPEMENT D'OPERATION

Toute erreur de câblage peut être une source de danger et de panne.

Lors des opérations d'entretien des commandes, étiqueter tous les fils avant de les déconnecter.

1. Disconnect orange wire from Low Heat Pressure Switch LPS on inducer housing (see Fig. 1)
2. Connect the orange wire from the Low Heat Pressure Switch to the orange wire with the insulated male spade terminal (see Fig. 19)
3. Connect the orange wire from the Low Gas Pressure Switch to the terminal on the Low Heat Pressure Switch.
4. Route orange wires along wire harness. If possible, secure with wire tie provided in kit.

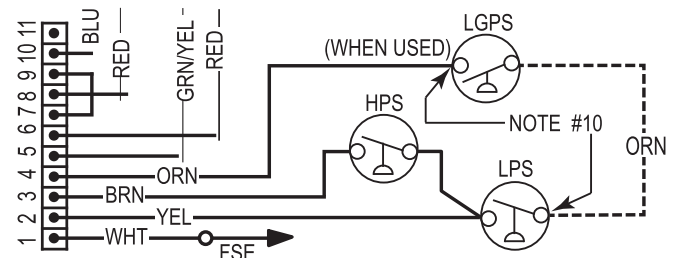

L13F016

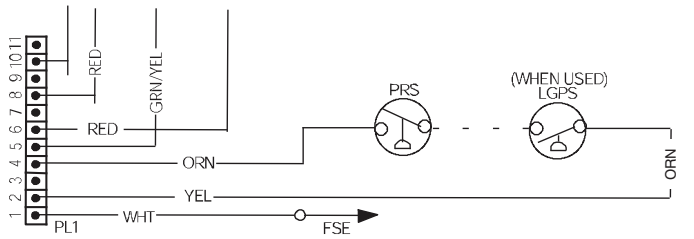

Fig. 19 – Pressure Switch Wiring

A190143

CHECK INLET GAS PRESSURE

! CAUTION

UNIT DAMAGE HAZARD

Failure to follow this caution may result in unit damage.
 DO NOT operate furnace more than one minute to check inlet gas pressure, as conversion is not complete at this time.

NOTE: This kit is to be used only when inlet gas pressure is between 12.0-in. w.c. and 13.6-in. w.c.

1. On some models, remove 1/8-in. (3 mm) pipe plug from inlet pressure tap (see Fig. 17 and Fig. 18) and insert pressure tap. Or, on some models, loosen set screw on inlet tower pressure tap no more than one full turn with the 3/32-in. hex wrench (see Fig. 10 and Fig. 11).
2. Verify manometer is connected to inlet pressure tap on gas valve (see Fig. 10 and Fig. 11).
3. Turn on furnace power supply.
4. Turn gas supply manual shutoff valve to ON position.
5. Turn furnace gas valve switch to ON position.

! WARNING

FIRE, EXPLOSION, ELECTRICAL SHOCK HAZARD

Failure to follow this warning could result in personal injury, death or property damage.
 Gas supply **MUST** be shut off before disconnecting electrical power and proceeding with conversion.

! WARNING

ELECTRICAL SHOCK, FIRE OR EXPLOSION HAZARD

Failure to follow this warning could result in personal injury, death or property damage.
 Before installing, modifying, or servicing system, main electrical disconnect switch must be in the OFF position and install a lockout tag. There may be more than one disconnect switch. Lock out and tag switch with a suitable warning label. Verify proper operation after servicing.

Single Stage Gas Valve

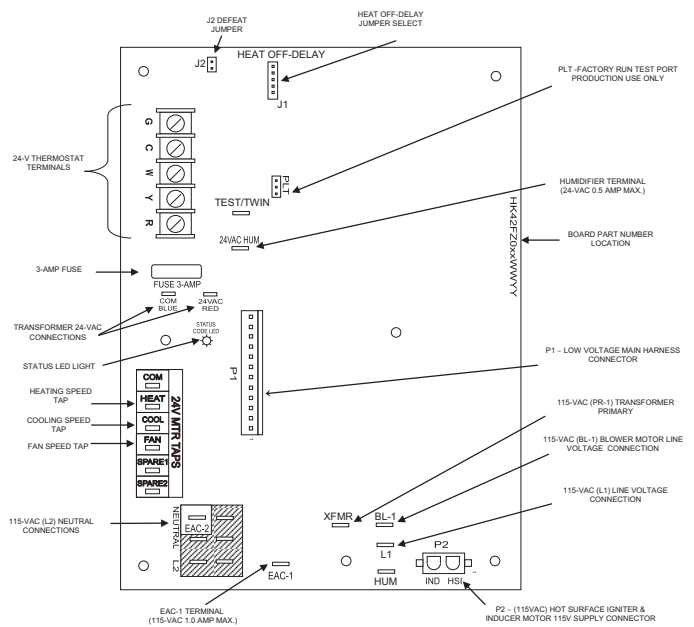
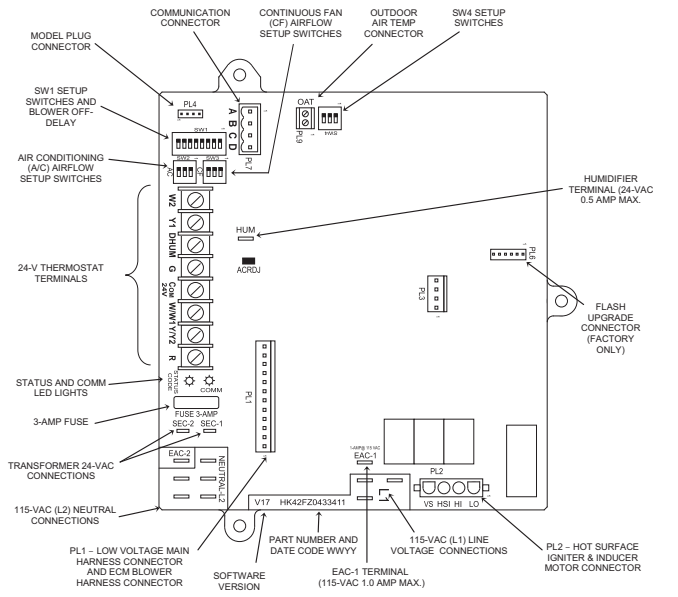

Fig. 20 – Example of Single Stage Furnace Control

A190022

1. Jumper R-W thermostat connections on control.
2. When main burners ignite, confirm inlet gas pressure is between 12.0-in. w.c. and 13.6-in. w.c.
3. Remove jumper across R-W thermostat connections to terminate call for heat.
4. Turn furnace gas valve switch to OFF position.
5. Turn gas supply manual shutoff valve to OFF position.
6. Turn off furnace power supply.
7. Remove manometer and on some models remove pressure tap fitting.
8. On some models, apply pipe dope sparingly to end of inlet gas pipe plug and install into unused end of 1/8-in. (3 mm) tee. Use a small back-up wrench on tee when tightening gas inlet pipe plug. Or, on some models, tighten set screw on inlet tower pressure tap with a 3/32-in. hex wrench (see Fig. 10 and Fig. 11).

Variable Speed Blower, Two-Stage Gas Valve



A200178

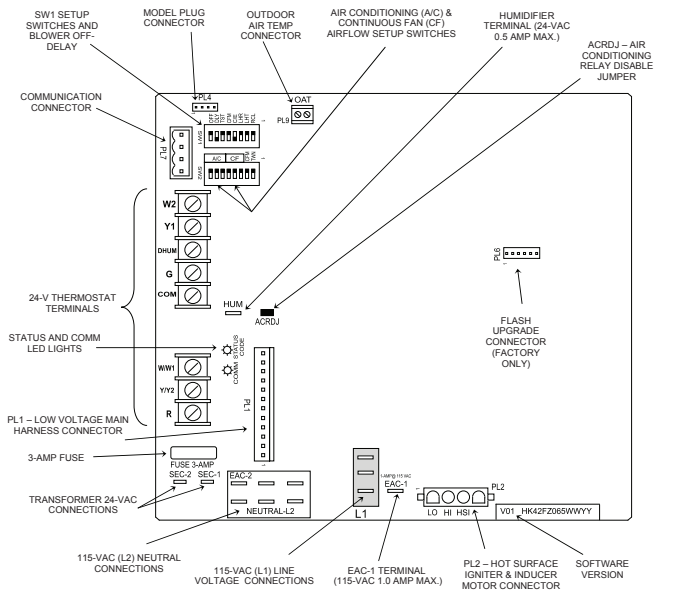
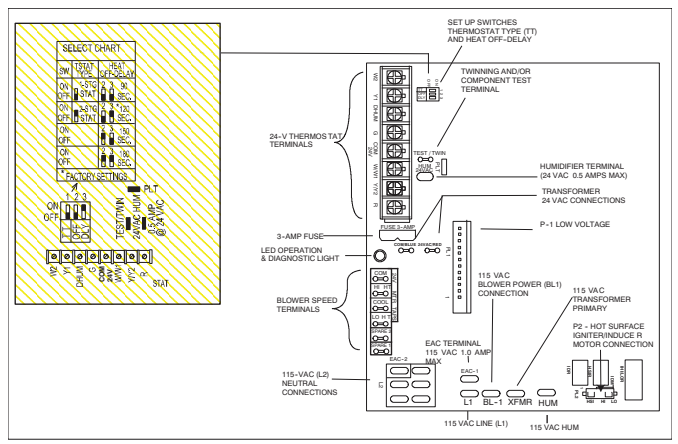

Fig. 21 – Example of Variable Speed Furnace Control for ECM (VCA) Blower Motor

1. Turn Setup Switch SW1-2 on furnace control ON (see Fig. 21).
2. Jumper R-W/W1 and R-W2 thermostat connections on control.
3. When main burners ignite, confirm inlet gas pressure is between 12.0-in. w.c. and 13.6-in. w.c.
4. Remove jumper across R-W/W1 and R-W2 thermostat connections to terminate call for heat.
5. Turn furnace gas valve switch to OFF position.
6. Turn gas supply manual shutoff valve to OFF position.
7. Turn off furnace power supply.
8. Remove manometer and on some models remove pressure tap fitting.
9. On some models, apply pipe dope sparingly to the end of inlet gas pipe plug and install into unused end of 1/8-in. (3 mm) tee. Use a small back-up wrench on tee when tightening gas inlet pipe plug.

Or, on some models, tighten set screw on inlet tower pressure tap with a 3/32-in. hex wrench (see Fig. 12 and Fig. 13).

Fixed Speed Blower (FCT), Two-Stage Gas Valve



A200177

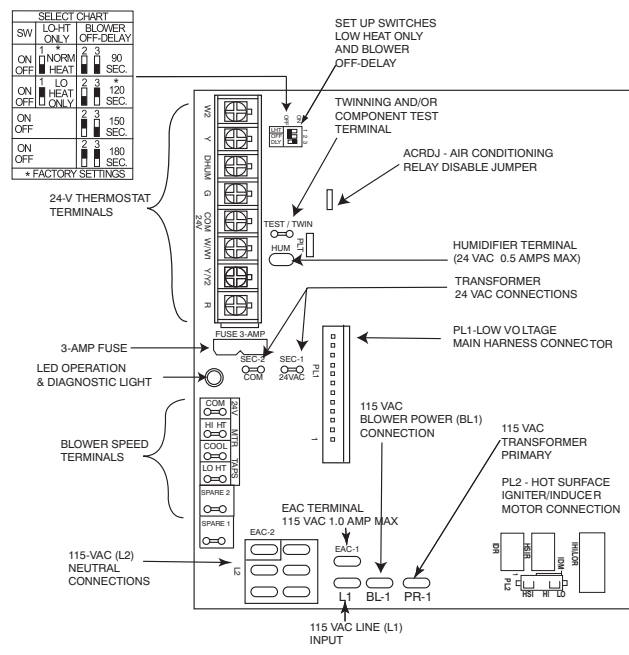

Fig. 22 – Example of Two-Stage Furnace Control

1. Turn Setup Switch SW1 (LHT or TT) on furnace control ON (see Fig. 22).
2. Jumper R-W/W1 and R-W2 thermostat connections on control.
3. When main burners ignite, confirm inlet gas pressure is between 12.0-in. w.c. and 13.6-in. w.c.
4. Remove jumper across R-W/W1 and R-W2 thermostat connections to terminate call for heat.
5. Turn furnace gas valve switch to OFF position.
6. Turn gas supply manual shutoff valve to OFF position.
7. Turn off furnace power supply.
8. Remove manometer and on some models remove pressure tap fitting.
9. On some models, apply pipe dope sparingly to the end of inlet gas pipe plug and install into unused end of 1/8-in. (3 mm) tee. Use a small back-up wrench on tee when tightening gas inlet pipe plug. Or, on some models, tighten set screw on inlet tower pressure tap no more than one full turn with a 3/32-in. hex wrench (see Fig. 12 and Fig. 13).

Modulating Gas Valve

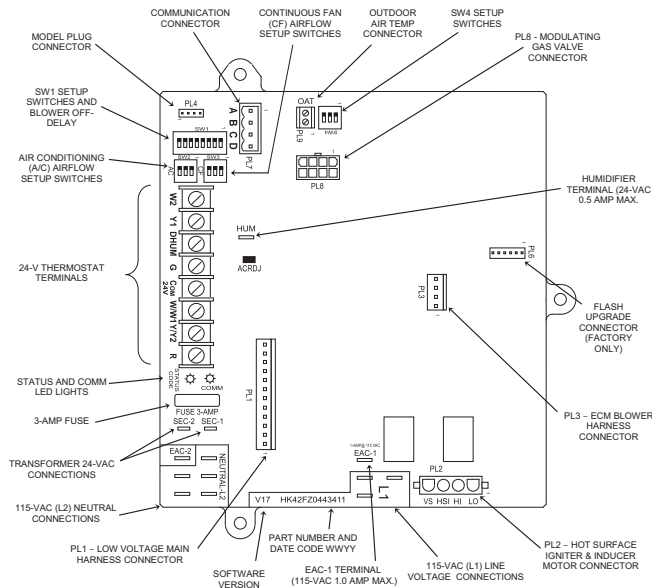

Fig. 23 – Example of Modulating Furnace Control for ECM Blower Motor L11F061

1. Turn Setup Switch SW1-2 on furnace control ON (see Fig. 23).
2. Jumper R-W/W1 and R-W2 thermostat connections on control.
3. When main burners ignite, confirm inlet gas pressure is between 12.0-in. w.c. and 13.6-in. w.c.
4. Remove jumper across R-W/W1 and R-W2 thermostat connections to terminate call for heat.
5. Turn furnace gas valve switch to OFF position.
6. Turn gas supply manual shutoff valve to OFF position.
7. Turn off furnace power supply.
8. Remove manometer and on some models remove pressure tap fitting.
9. On some models, apply pipe dope sparingly to the end of inlet gas pipe plug and install into unused end of 1/8-in. (3 mm) tee. Use a small back-up wrench on tee when tightening gas inlet pipe plug. Or, on some models, tighten set screw on inlet tower pressure tap with a 3/32-in. hex wrench (see Fig. 16 through Fig. 18).

CHECK FURNACE AND MAKE ADJUSTMENTS

! WARNING

FIRE OR EXPLOSION HAZARD

Failure to follow this warning could result in personal injury, death, and/or property damage.

Never test for gas leaks with an open flame. Use a commercially available soap solution made specifically for the detection of leaks to check all connections. A fire or explosion may result causing property damage, personal injury or loss of life.

! AVERTISSEMENT

RISQUE D'EXPLOSION ET D'INCENDIE

Le non-respect des avertissements de sécurité pourrait d'entraîner des blessures graves, la mort ou des dommages matériels.

Ne jamais utiliser une flamme nue pour vérifier la présence des fuites de gaz. Pour la vérification de tous les joints, utiliser plutôt une solution savonneuse commerciale fabriquée spécifiquement pour la détection des fuites de gaz. Un incendie ou une explosion peut entraîner des dommages matériels, des blessures ou la mort.

1. Be sure main gas and electric supplies to furnace are off.
2. On some models, remove 1/8-in. (3 mm) pipe plug from manifold pressure tap on the outlet end of gas valve and insert pressure tap. Or, on some models, loosen the set screw on manifold tower pressure tap no more than one full turn with the 3/32-in. hex wrench.
3. Attach manometer to manifold pressure tap on gas valve (see Fig. 10, Fig. 11, Fig. 12, Fig. 13 or Fig. 16).
4. Turn gas supply manual shutoff valve to ON position.
5. Turn furnace gas valve switch to ON position.
6. Check all threaded pipe connections for gas leaks.
7. Turn on furnace power supply.

GAS INPUT RATE INFORMATION

The gas input rate for propane is the same as for natural gas. See furnace rating plate (see Fig. 5) for input rate. The input rate for propane is determined by manifold pressure and orifice size.

Modulating gas valve must be set for Maximum Heat first and then set for Minimum heat on Modulating furnaces.

Two-Stage gas valve must be set for High Heat first and then set for Low Heat on Two-Stage furnaces.

Furnace gas input rate on rating plate is for installations at altitudes up to 2000 ft. (610 M).

In the U.S.A.; the input rating for altitudes above 2000 ft. (610M) must be reduced by 2 percent for each 1000 ft. (305 M) above sea level.

In Canada; the input rating must be derated by 5 percent for altitudes of 2000 ft. (610 M) to 4500 ft. (1372 M) above sea level.

The Conversion Kit Rating Plate accounts for high altitude derate.

SET GAS INPUT RATE

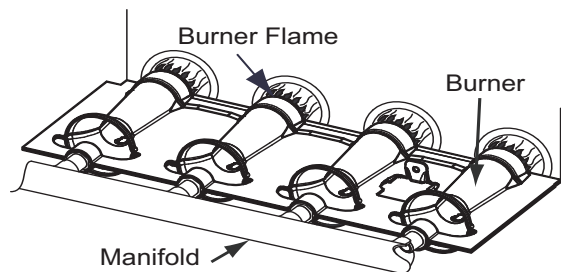

Fig. 24 – Burner Flame A11461

Single Stage Gas Valve

1. Jumper R and W thermostat connections to call for heat (see Fig. 20).
2. Check manifold orifices for gas leaks when main burners ignite.
3. Adjust gas manifold pressure.
4. Remove cap that conceals gas valve regulator adjustment screw.
5. Turn adjusting screw counterclockwise (out) to decrease manifold pressure or clockwise (in) to increase manifold pressure.
6. Replace gas valve regulator seal cap.

7. Verify manifold pressure is correct.

NOTE: Gas valve regulator seal cap **MUST** be in place when checking input rate. When correct input is obtained, main burner flame should be clear blue, almost transparent (see Fig. 24). Be sure regulator seal cap is in place when finished.

8. Remove jumper across R and W thermostat connections to terminate call for heat.
9. Turn furnace gas valve control switch or control knob to OFF position.
10. Turn off furnace power supply.
11. Remove manometer and on some models remove pressure tap fitting.
12. On some models, apply pipe dope sparingly to end of 1/8-in. (3 mm) pipe plug and install in the manifold pressure tap opening. Or, on some models, tighten set screw on manifold tower pressure tap with a 3/32-in. hex wrench (see Fig. 10 or Fig. 11)
13. Turn furnace gas-valve switch to ON position.
14. Turn on furnace power supply.
15. Set room thermostat to call for heat.
16. Check pressure tap plug for gas leaks when main burners ignite.
17. Check for correct burner flame.
18. After making the required manifold pressure adjustments, check and adjust the furnace temperature rise per the furnace installation instructions.

Fixed-Speed Blower (FCT), Two-Stage Gas Valve

1. Verify SW1 (LHT or TT) on furnace control is turned “ON” (see Fig. 22).
2. Jumper R and W/W1 thermostat connections to call for heat.
3. Check manifold orifices for gas leaks when main burners ignite.
4. Adjust gas manifold pressure.
5. Remove caps that conceal adjustment screws for gas valve regulators (see Fig. 12 or Fig. 13).
6. Adjust low heat input rate manifold pressure for propane gas.
7. Turn low heat adjusting screw counterclockwise (out) to decrease input rate or clockwise (in) to increase input rate.
8. When correct input is obtained, main burner flame should be clear blue, almost transparent (see Fig. 24).
9. Jumper R and W/W1 and W2 on control center thermostat connections. This keeps furnace locked in high heat operation.
10. Adjust high heat input rate manifold pressure for propane gas.
11. Turn high heat adjusting screw counterclockwise (out) to decrease input rate or clockwise (in) to increase input rate.
12. Replace caps that conceal gas valve regulator adjustment screws.
13. When correct input is obtained, main burner flame should be clear blue, almost transparent (see Fig. 24).
14. Remove jumper across R, W1, and W2 after high heat adjustment to terminate call for heat.
15. Turn setup switch SW1 (TT) on furnace control to OFF position.
16. Turn furnace gas-valve switch to OFF position.
17. Turn off furnace power supply.
18. Remove manometer from the manifold pressure tap of the gas valve.
19. On some models, apply pipe dope sparingly to end of 1/8-in. (3 mm) pipe plug and install in the manifold pressure tap opening. Or, on some models, tighten set screw on manifold tower pressure tap with a 3/32-in. hex wrench (see Fig. 12 or Fig. 13).
20. Turn on furnace power supply.
21. Set room thermostat to call for heat.
22. Check pressure tap plug for gas leaks when main burners ignite.

23. Check for correct burner flame.

24. After making the required manifold pressure adjustments, check and adjust the furnace temperature rise per the furnace installation instructions.

Variable Speed, Two-Stage Gas Valve

1. Verify SW1-2 on furnace control is turned “ON”.
2. Jumper R and W/W1 thermostat connections to call for heat.
3. Check manifold orifices for gas leaks when main burners ignite.
4. Adjust gas manifold pressure. Refer to Conversion Kit Rating Plate 346161-201
5. Remove caps that conceal adjustment screws for gas valve regulators (see Fig. 12 or Fig. 13).
6. Adjust low-heat manifold pressure for propane gas (see Fig. 12 or Fig. 13).
7. Turn low-heat adjusting screw counterclockwise (out) to decrease input rate or clockwise (in) to increase input rate.

NOTE: When correct input is obtained, main burner flame should be clear blue, almost transparent (see Fig. 24).

8. Jumper R, W/W1 and W2 on control center thermostat connections. This keeps furnace locked in high-heat operation.
9. Adjust high-heat manifold pressure for propane gas.
10. Turn high-heat adjusting screw counterclockwise (out) to decrease input rate or clockwise (in) to increase input rate.
11. Replace caps that conceal gas valve regulator adjustment screws.

NOTE: When correct input is obtained, main burner flame should be clear blue, almost transparent (see Fig. 24).

12. Remove jumper across R, W1, and W2 after high-heat adjustment to terminate call for heat.
13. Turn setup switch SW1-2 on furnace control to OFF position.
14. Turn furnace gas valve switch to OFF position.
15. Turn off furnace power supply.
16. Remove manometer from the manifold pressure tap of the gas valve.
17. On some models, apply pipe dope sparingly to end of 1/8-in. (3 mm) pipe plug and install in the manifold pressure tap opening. Or, on some models, tighten set screw on manifold tower pressure tap with a 3/32-in. hex wrench (see Fig. 12 or Fig. 13).
18. Turn furnace gas valve switch to ON position.
19. Turn on furnace power supply.
20. Set room thermostat to call for heat.
21. Check pressure tap plug for gas leaks when main burners ignite.
22. Check for correct burner flame.
23. Observe unit operation through two complete heating cycles.
24. See Sequence of Operation in furnace Installation, Start-up, and Operating Instructions.
25. Set room thermostat to desired temperature.
26. After making the required manifold pressure adjustments, check and adjust the furnace temperature rise per the furnace installation instructions.

Modulating Gas Valve

! CAUTION

UNIT DAMAGE HAZARD

Failure to follow this caution may result in gas valve damage.

DO NOT force the rotary adjustment switch on the modulating gas valve. **DO NOT** turn the rotary adjustment switch faster than one click per second when adjusting manifold pressure. Gas valve will be damaged if excessive force is used on the rotary switch.

For proper operation and long term reliability, the manifold pressure must be adjusted as specified on the conversion kit rating plate.

The modulating furnace manifold pressure is set at two points. The first point is Maximum Heat. The second point is Minimum Heat. Do not adjust Intermediate Heat manifold pressure. Intermediate Heat manifold pressure can be checked as part of the temperature rise, but is not adjustable. Always adjust Maximum Heat first, then Minimum Heat.

NOTE: DO NOT set Maximum Heat manifold pressure less than 10.5-in. w.c. or more than 11-in. w.c. for propane gas.

NOTE: Use care when performing adjustments. Gas valve adjustment is performed by turning a rotary adjustment switch inside the gas valve with a small straight blade screwdriver. Excessive force can break or bend the rotary adjustment switch making it non-adjustable.

To adjust manifold pressure to obtain input rate for Maximum Heat:

1. Turn Setup switch SW1-2 to ON.
2. Verify Set-up switch SW4-2 is turned OFF.
3. Jumper the R to W/W1 and W2 thermostat connections at the furnace control board.
4. After the main burners ignite and the blower starts, confirm Maximum Heat manifold pressure is correct, based on the manifold pressure table on the Conversion Kit Rating Plate.
5. To adjust the Maximum Heat manifold pressure, Slowly turn the rotary adjustment switch counterclockwise to decrease manifold pressure or clockwise to increase manifold pressure.
6. Turn rotary adjustment switch no more than one click per second until you obtain the required manifold pressure.

Main burner flame should be clear blue, almost transparent.

To adjust manifold pressure to obtain input rate for Minimum Heat:

1. Remove the jumper from W2 at the thermostat connections at the furnace control board control.
2. Wait until the burners and the blower transitions to Minimum Heat.
3. Verify the Minimum Heat manifold pressure is correct, based on the manifold pressure table on Conversion Kit Rating Plate.
4. To adjust the Minimum Heat manifold pressure, Slowly turn the rotary adjustment switch counterclockwise to decrease manifold pressure or clockwise to increase manifold pressure.
5. Turn rotary adjustment switch no more than one click per second until you obtain the required manifold pressure. This adjustment will not affect the previous Maximum Heat adjustment.

After adjusting the manifold pressure, allow the furnace to operate an additional 5 minutes before checking Minimum Heat Temperature rise.

Furnace must operate within ranges of temperature rise specified on the furnace rating plate. Determine air temperature rise as follows:

1. Place thermometers in return and supply ducts as near furnace as possible. Be sure thermometers do not see heat exchanger so that radiant heat does not affect readings. This practice is particularly important with straight-run ducts.

2. When thermometer readings stabilize, subtract return-air temperature from supply-air temperature to determine air temperature rise.
3. Allow the furnace to run for at least 10 minutes before checking Temperature Rise.

If the temperature rise is too high or too low in Minimum Heat:

1. Remove jumpers from R and W/W1.
2. Wait until the blower off delay is completed.
3. Turn 115 VAC power off.
4. Check the position of Heat Rise Adjustment Switch SW1-3. When set to ON, airflow is raised 18% higher for Minimum Heat and Intermediate Heat. Factory default position is OFF.
5. Turn 115 VAC power on.
6. Jumper R to W/W1 and W2.
7. After burners ignite and blower starts allow the furnace to run for at least 10 minutes before checking Temperature Rise.

Maximum Heat Temperature Rise

If the temperature rise is too high or too low in Maximum Heat:

1. Remove jumpers from R, W1 and W2.
2. Wait until the blower off delay is completed.
3. Turn 115 VAC power off.
4. Check the position of the Efficiency/Comfort Adjustment switch SW1-4. When set to OFF (Efficiency Mode), airflow is 10% higher for Minimum, 7.5% for Intermediate Heat, and 17.5% for Maximum Heat. Factory default position is ON (Comfort Mode).
5. Turn 115 VAC power on.
6. Re-check Minimum Heat Temperature Rise.
7. Remove jumpers across thermostat connections to terminate the call for heat. Wait until the blower off delay is completed.
8. Turn gas supply manual shutoff valve to OFF position.
9. Turn off furnace power supply. Turn setup switch SW1-2 to OFF.
10. Remove manometer from the manifold pressure tap of the gas valve.
11. On some models, apply pipe dope sparingly to end of 1/8-in. (3 mm) pipe plug and install in the manifold pressure tap opening (see Fig. 16). Or, on some models, tighten set screw on manifold tower pressure tap with a 3/32-in. hex wrench (see Fig. 25).

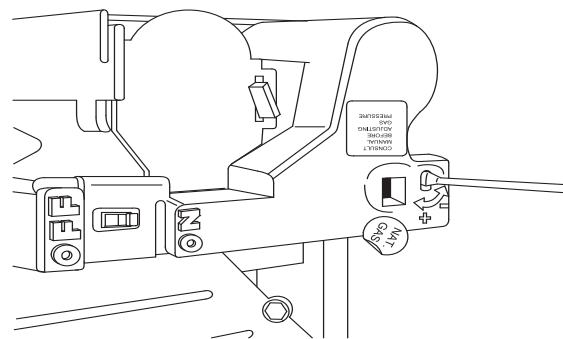

Fig. 25 – Modulating Gas Valve Adjustment

A11451

12. Re-install plastic cap over rotary adjustment switch on the top of the gas valve.

! WARNING

FIRE HAZARD

Failure to follow this warning could result in personal injury, death, and/or property damage.

Manifold pressure tap set screw must be tightened or 1/8-in. (3 mm) NPT pipe plug must be installed to prevent gas leaks.

13. Turn furnace gas valve switch to ON position.
14. Turn on furnace power supply.
15. Set room thermostat to call for heat.
16. Check pressure tap plug for gas leaks when main burners ignite.
17. Check for correct burner flame.

CHECK LOW GAS PRESSURE SWITCH

The newly installed low gas pressure switch is a safety device used to guard against adverse burner operating characteristics that can result from low gas supply pressure. Switch opens at not less than 7.2 in. w.c. and closes at not greater than 10.2 in. w.c.

This switch also prevents operation when the propane tank level is low which can result in gas with a high concentration of impurities, additives, and residues that have settled to the bottom of the tank. Operation under these conditions can cause harm to the heat exchanger system. This normally open switch closes when gas is supplied to gas valve under normal operating pressure.

The closed switch completes control circuit. Should an interruption or reduction in gas supply occur, the gas pressure at switch drops below low gas pressure switch setting, and switch opens. Any interruption in control circuit (in which low gas pressure switch is wired) quickly closes gas valve and stops gas flow to burners. When normal gas pressure is

restored, the system must be electrically reset to re-establish normal heating operation.

Before leaving installation, observe unit operation through two complete heating cycles. During this time, turn gas supply to gas valve off just long enough to completely extinguish burner flame, then instantly restore full gas supply. To ensure proper low gas pressure switch operation, observe that there is no gas supply to burners until after hot surface igniter begins glowing.

LABEL APPLICATION

1. Fill in Conversion Responsibility Label 346161-205 and apply to Blower Access Door of furnace. Date, name, and address of organization making this conversion are required (see Fig. 26,).
2. Attach Conversion Rating Plate Label 346161-201 to outer door of furnace (see Fig. 5).
3. Attach Gas Control Conversion Label 346161-202 to gas valve. Do not use 346161-203, which is similar.

CHECKOUT

1. Observe unit operation through two complete heating cycles.
2. See Sequence of Operation in furnace Installation, Start-Up, and Operating Instructions.
3. Set room thermostat to desired temperature.

<p>THIS FURNACE WAS CONVERTED ON _____ TO PROPANE GAS <small>(DAY-MONTH-YEAR)</small> KIT NO.: AGAGC9NPS01B</p> <p>BY: _____ _____ _____</p> <p><small>(Name and address of organization making this conversion), which accepts the responsibility that this conversion has been properly made.</small></p>	<p>CETTE FOURNAISE A ÉTÉ CONVERTIE AU GAZ PROPANE LE _____ <small>(JOUR-MOIS-ANNÉE)</small> DE L'ENSEMBLE N°.: AGAGC9NPS01B</p> <p>PAR: _____ _____ _____</p> <p><small>(Nom et adresse de l'organisme qui a effectué la conversion), qui accepte l'entière responsabilité de la conversion.</small></p> <p style="text-align: right;"><small>346161-205 REV.A</small> </p>
---	---

Fig. 26 – Gas Conversion Responsibility Label

A200209

<p><small>This control has been converted for use with propane gas. Ce contrôle a été converti pour fonctionner au gaz propane.</small></p> <p style="text-align: right;"><small>346161-202 REV.A</small> </p>	<p><small>This control has been adjusted for use with propane gas. Ce contrôle a été réglée pour fonctionner au gaz propane.</small></p> <p style="text-align: right;"><small>346161-203 REV.A</small> </p>
--	---

Fig. 27 – Gas Control Conversion Label

A200207

