

Installation Instructions

NOTE: Read the entire instruction manual before starting the installation.

SAFETY CONSIDERATIONS

Follow all safety codes. Wear safety glasses, protective clothing, and work gloves. Have a fire extinguisher available. Read these instructions thoroughly and follow all warnings and cautions included in literature and attached to the unit. Consult local building codes and the current edition of the National Electrical Code (NEC) NFPA 70.

In Canada, refer to the current editions of the Canadian Electrical Code CSA C22.1.

Recognize safety information. When you see this symbol  on the unit and in instructions or manuals, be alert to the potential for personal injury. Understand the signal words **DANGER**, **WARNING**, and **CAUTION**. These words are used with the safety-alert symbol. **DANGER** identifies the most serious hazards, which **will** result in severe personal injury or death. **WARNING** signifies hazards, which **could** result in personal injury or death. **CAUTION** is used to identify unsafe practices, which **may** result in minor personal injury or product and property damage. **NOTE** is used to highlight suggestions which **will** result in enhanced installation, reliability, or operation.

INTRODUCTION

These instructions cover the installation of the condensate pan extension kit 343679-701.

CAUTION

CUT HAZARD

Failure to follow this caution may result in personal injury. Sheet metal parts may have sharp edges or burrs. Use care and wear appropriate protective clothing and gloves when handling parts.

Kit Contents	
Quantity	Description
1	Pan Extension
2	Corner screws
1	Cork Tape
1	Installation Instructions

INSTALLATION

1. For horizontal-right installation, install pan extension onto right end of horizontal condensate pan. Pan extension is slotted to fit onto condensate pan edge and will extend into supply plenum.
2. Use cork tape to create air seal between the undersides of the pan extension and front of the vertical drain pan as shown in **Fig. 1**.
3. Install condensate pan extension and two corner screws as shown in **Fig. 2**.

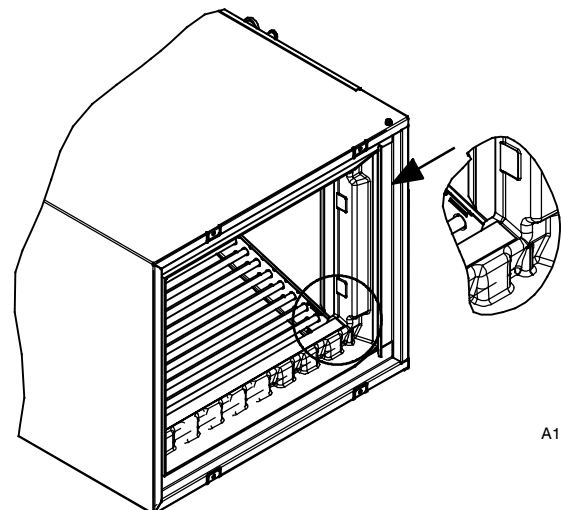

A170282

Fig. 1 - Condensate Pan Extension Cork Tape Location

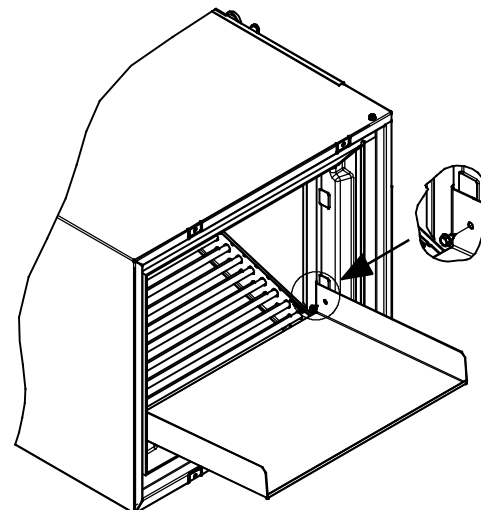

Fig. 2 - Condensate Pan Extension Mounting Screws