

Part Number:  
 CPRFCURB011B00  
 CPRFCURB013B00

SMALL PACKAGED PRODUCT (SPP)  
 ACCESSORY ROOFCURBS


## Installation Instructions

### SAFETY CONSIDERATIONS

Installation and servicing of air-conditioning equipment can be hazardous due to system pressure and electrical components. Only trained and qualified service personnel should install, repair, or service air-conditioning equipment.

Untrained personnel can perform the basic maintenance functions of replacing filters. All other operations should be performed by trained service personnel. When working on air-conditioning equipment, observe precautions in the literature, tags, and labels attached to the unit, and other safety precautions that may apply.

Follow all safety codes. Wear safety glasses, protective clothing, and work gloves. Use quenching cloth for brazing operations. Have a fire extinguisher available. Read these instructions thoroughly and follow all warnings or cautions included in literature and attached to the unit.

Recognize safety information. This is the safety-alert symbol . When you see this symbol on the unit and in instructions or manuals, be alert to the potential for personal injury. Understand these signal words; DANGER, WARNING, and CAUTION. These words are used with the safety-alert symbol. DANGER identifies the most serious hazards which **will** result in severe personal injury or death. WARNING signifies hazards which **could** result in personal injury or death. CAUTION is used to identify unsafe practices which **may** result in minor personal injury or product and property damage. NOTE is used to highlight suggestions which **will** result in enhanced installation, reliability, or operation.

Consult local building codes, the current editions of the National Fuel Gas Code (NFGC) NFPA 54/ANSI 2223.1, and the National Electrical Code (NEC) NFPA 70.

In Canada refer to the current editions of the National Standards of Canada CAN/CSA-B149.1 and .2 Natural Gas and Propane Installation codes, and Canadian Electrical Code CSA C22.1

#### \*IMPORTANT NOTES:

- When installing a large cabinet on CPRFCURB011B00, the provided hold down brackets must be used to keep the unit from tipping. Brackets must be installed before unit is set. See Figure 4, 5 and 6.
- The location of the center supports will vary depending on cabinet size. See Fig. 3 and 4.


 <b>WARNING</b>
<b>UNIT FALLING HAZARD</b>
Failure to follow this warning could result in personal injury or death. Do not install the large cabinet Packaged Dual Fuel units onto these curbs. The center of gravity could overhang the curb causing an unsafe condition.

Table 1 - Package Contents


DESCRIPTION	CPRFCURB011B00	CPRFCURB013B00
Curb Sides	2	2
Curb Ends	2	2
Deck Pan-Insulated	1	2
Long Support	1	1
Side Supports	2	2
Center Supports	2	2
Gasket 3/4-in. Thick x 16 ft.	1	1
Gasket 1/4-in. Thick x 16 ft.	1	1
Hold Down Bracket	2	-

Table 2 - Package Usage

CURB PART NUMBER	UNIT
CPRFCURB011B00	small or large cabinet*
CPRFCURB013B00	large cabinet

\*Hold down brackets only used when large cabinet is set on CPRFCURB011B00

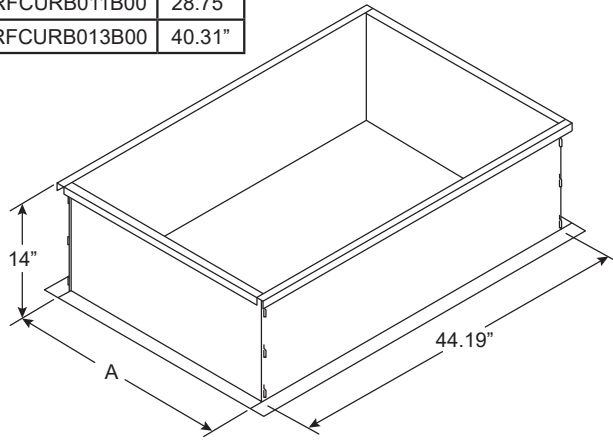
### INSTALLATION

 <b>WARNING</b>
<b>PERSONAL INJURY AND EQUIPMENT DAMAGE HAZARD</b>
Failure to follow this warning could result in personal injury and/or damage to equipment.
Do not leave roof opening uncovered. If installation is not completed immediately after roof opening is cut and framed, provide an adequate temporary cover for the roof opening.

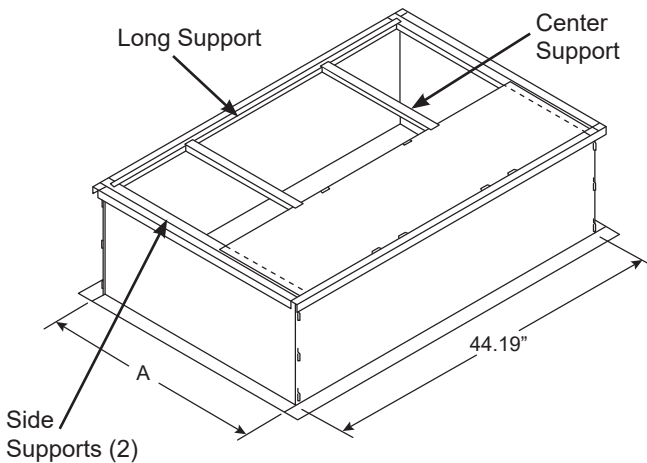
- Before installing the roof curb, ensure that curb is located so that proper clearances are maintained. Ensure that roof structural integrity is capable of supporting weight of rooftop unit. Adding structural support to roof bracing may be necessary. Check unit nameplate or units installation instructions for correct clearances.
- Cut hole in roof for duct openings. (See Fig. 3 and 4.) It is not necessary to cut out the entire area of the roof curb.
- Frame the roof curb opening to provide adequate structural support.
- Assemble the roof curb. Bring together a curb side and a curb end. Insert the tabs in the curb end into the slots on the curb side. Press together until the pieces lock in place. Corners should be flush. (See Fig. 1.)
- Repeat for all four corners. If lifting the curb assembly, bend all corner tabs over to the side. (See Fig. 1.)
- Install the side supports on each end of the roof curb. (See Fig 2, 3 and 4.)

**IMPORTANT:** Gasketing is critical for water integrity. Improperly installed gasketing can result in air leaks and poor unit performance.

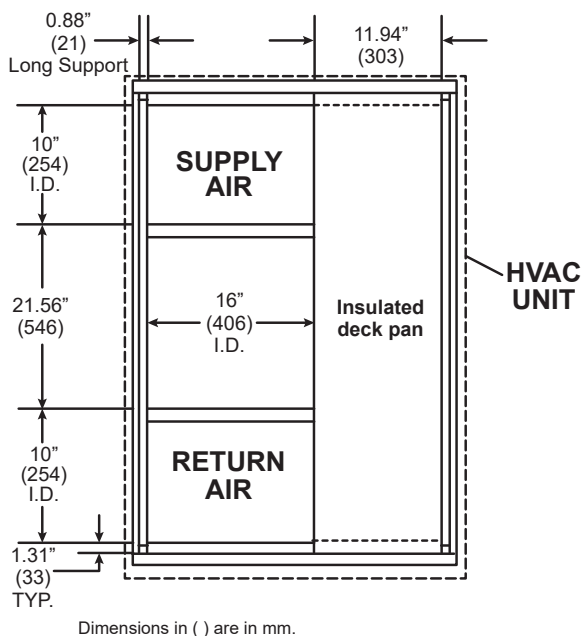
Roofcurb Part No.	A
CPRFCURB011B00	28.75"
CPRFCURB013B00	40.31"



**Fig. 1 - Roof Curb Detail**



**Fig. 2 - Roof Curb Detail (Small Cabinet Curb Shown)**

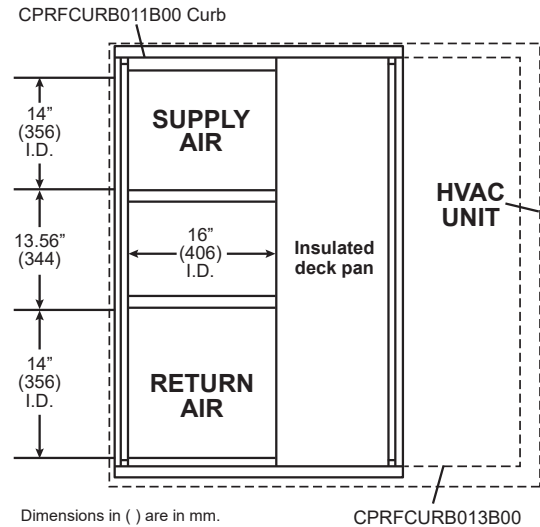


**Fig. 3 - CPRFCURB011B00 Curb with Small Cabinet**

7. Install the insulated deck pan(s) on the compressor side of the roof curb.
8. Install the long support on the side opposite of the deck pan (See Fig. 2, 3 and 4).
9. Install the center supports to frame the supply and return duct openings. (See Fig. 2 and 3.)

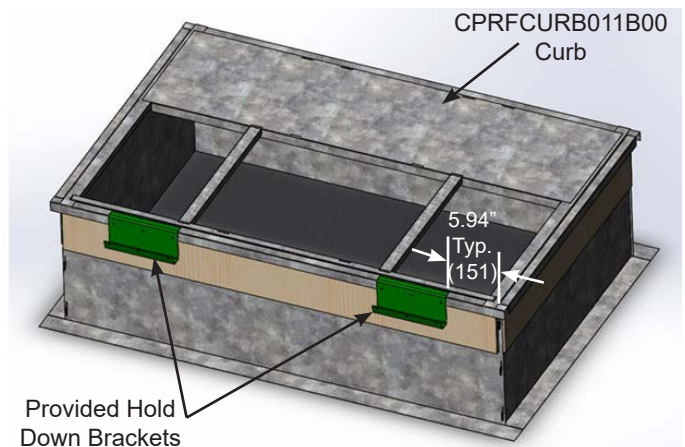
**IMPORTANT:** The CPRFCURB011B00 is designed to fit small and large cabinet SPP units. The large cabinet unit will have significant overhang, and provided brackets must be installed before unit is set. See Fig. 5 and 6.

The CPRFCURB013B00 is designed specifically for the large cabinet unit.

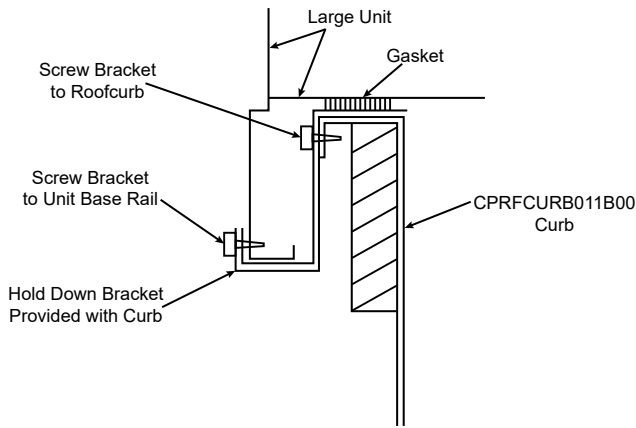


**Fig. 4 - CPRFCURB011B00 Setup for Large Cabinet or CPRFCURB013B00**

10. Square up the roof curb and position over the duct openings cut in Step 2. Level the curb by placing shims (thin pieces of wood or metal) under the bottom flange of the curb. See Fig. 8 for unit leveling tolerances.
11. Secure the curb in place by welding or screwing curb to the roof (field supplied equipment required).
12. When using the CPRFCURB011B00 curb with the large cabinet install hold down brackets per Fig 5 and 6. Holes are pre-punched on curb flange for locating purposes.

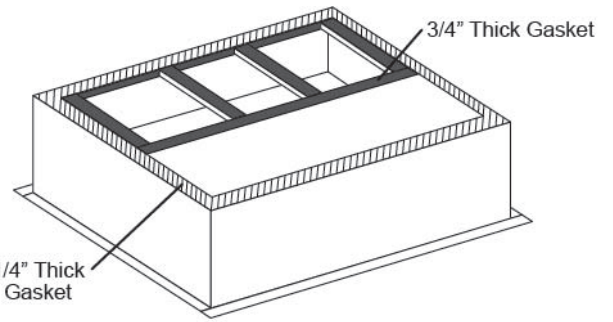




**Fig. 5 - Hold Down Brackets For CPRFCURB011B00 Curb used with Large Cabinet Unit**



**Fig. 6 - Bracket Attachment**

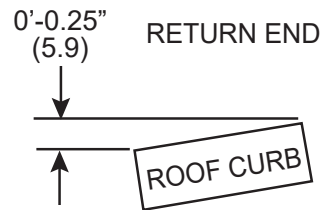
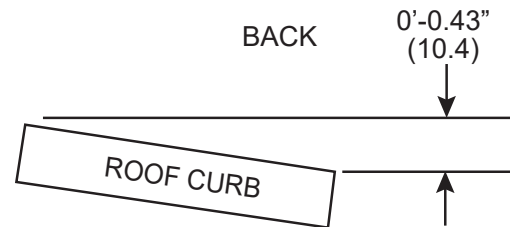
13. Attach ductwork to the curb. Ductwork **MUST** be installed before unit is set in place.
14. Weatherproof and flash the roof curb per applicable codes.
15. Install provided 1/4-in. thick closed-cell gasket seal on the outer/top perimeter of the roof curb. (See Fig. 7.) When installed, the weight of the unit will compress the gasket to seal the joint between the unit and the roof curb. Gasket strips must fit tightly together and leave no gaps for leakage.
15. Install provided 3/4-in. thick gasket seal around the duct opening. (See Fig. 7.)



 3/4" Thick Gasket  
 1/4" Thick Gasket

**Fig. 7 - Roof Curb Detail**

A09670



NOTE: Dimensions in ( ) are in mm.

**Fig. 8 - Unit Leveling Tolerances**

**⚠ CAUTION**

**EQUIPMENT DAMAGE HAZARD**

Failure to follow this caution may result in property damage.

Do not slide unit into position when it is sitting on the curb. Curb gasketing material may be damaged and leaks may result.

**⚠ CAUTION**

**UNIT FALLING HAZARD**

Failure to follow this warning could result in personal injury or death.

When installing the large cabinet unit CPRFCURB011B00 curb (see Fig 4), the provided hold down brackets must be installed on the curb and attached to the unit to keep unit from tipping, See Fig 5 and 6.