

Outdoor Unit Multi-zone Heat Pump Ductless System

Outdoor Model: **DLCMRAH48EAK**

Submittal Data

Job Data: Location:

Buyer: Buyer P.O. #: Carrier #:

Unit Number: Model Number:

Performance Data Certified By: Date:



MULTI-ZONE STANDARD FEATURES

Features Outdoor:

- Connect up to 5, multiple style indoor units
 - High Wall
 - Cassette
 - Ducted
 - Floor Console
- Variable Speed (Inverter) Compressor
- Basepan Heater factory installed
- Quiet operation
- Anti-corrosive fin coating

Cooling operating range -13°~122° F (-25°~50° C)

Heating operating range -22°~86° F (-30°~30° C)

Compatibility Table

For matched compatibility see Product Data

INDOOR UNIT	
High Wall	DLFPHAH09XAK
	DLFPHAH12XAK
	DLFSHAH09XAK
	DLFSHAH12XAK
	DLFSHAH18XAK
	DLFSHAH24XAK
	DLFEHAH09XAK
	DLFEHAH12XAK
	DLFEHAH18XAK
	DLFEHAH24XAK
Cassette	DLFSCAH09XAK
	DLFSCAH12XAK
	DLFSCAH18XAK
	DLFSCAH24XAK
Ducted	DLFSDAH09XAK
	DLFSDAH12XAK
	DLFSDAH18XAK
	DLFSDAH24XAK
Console	DLFSFAH12XAK
	DLFSFAH18XAK
	DLFSFAH24XAK

Specifications

System	Size	48	
	Outdoor Model	DLCMRAH48EAK	
	Max Number of Zones	5	
Performance Non-Ducted	Energy Star	NO	
	Cooling System Tons	4.0	
	Cooling Rated Capacity	Btu/h	48,000
	Cooling Cap. Range Min - Max	Btu/h	8560-53160
	SEER	20.5	
	EER	11	
	Heating Rated Capacity (47°F)	Btu/h	48,000
	Heating Maximum Capacity (5°F)	Btu/h	37,900
	Heating Cap. Range Min - Max	Btu/h	7210-55820
	HSPF	10.2	
	COP (47°F)	W/W	3.5
COP (5°F)	W/W	2.76	
Performance Combination Ducted and Non-Ducted	Energy Star	NO	
	Cooling System Tons	4.0	
	Cooling Rated Capacity	Btu/h	48,000
	Cooling Cap. Range Min - Max	Btu/h	8510-52580
	SEER	19.05	
	EER	10.55	
	Heating Rated Capacity (47°F)	Btu/h	49,000
	Heating Maximum Capacity (5°F)	Btu/h	37,350
	Heating Cap. Range Min - Max	Btu/h	7045-54935
	HSPF	10.15	
	COP (47°F)	W/W	3.45
COP (5°F)	W/W	2.29	
Performance Ducted	Energy Star	NO	
	Cooling System Tons	4.0	
	Cooling Rated Capacity	Btu/h	48,000
	Cooling Cap. Range Min - Max	Btu/h	8460-52000
	SEER	17.6	
	EER	10.1	
	Heating Rated Capacity (47°F)	Btu/h	50,000
	Heating Maximum Capacity (5°F)	Btu/h	36,800
	Heating Cap. Range Min - Max	Btu/h	6880-54050
	HSPF	10.1	
	COP (47°F)	W/W	3.4
COP (5°F)	W/W	1.82	

Operating Range	Cooling Outdoor DB Min - Max	°F(°C)	-13-122 (-25-50)
	Heating Outdoor DB Min - Max	°F(°C)	-22-86 (-30-30)
Piping	Total Piping Length	ft (m)	328 (100)
	Piping to furthest FCU	ft (m)	115 (35)
	Drop (OD above ID)	ft (m)	65 (20)
	Lift (OD below ID)	ft (m)	65 (20)
	Pipe Connection Size - Liquid	in (mm)	1/4"5(6.35"5)
	Pipe Connection Size - Suction	in (mm)	1/2"2+ 3/8"3 (12.7"2+9.52"3)
Refrigerant	Type	R410A	
	Charge	lbs (kg)	10.13 (4.6)
	Metering Device	EEV	
Electrical	Voltage, Phase, Cycle	V/Ph/Hz	208/230-1-60
	Power Supply	0	
	MCA	A.	35
	MOCP - Fuse Rating	A.	50
Compressor	Type	R410A	
	Model	ATQ360D1UMU	
	Oil Type	ESTER OIL VG74	
	Oil Charge	Fl. Oz.	49.38
	Rated Current	RLA	21
Outdoor	Unit Width	in (mm)	41.15 (1045)
	Unit Height	in (mm)	52.48 (1333)
	Unit Depth	in (mm)	17.63 (448)
	Net Weight	lbs (kg)	223.8 (101.5)
	Airflow	CFM	4500
Sound Pressure	dB(A)	64	

Construction View

Outdoor Model: DLCMRAH48EAK

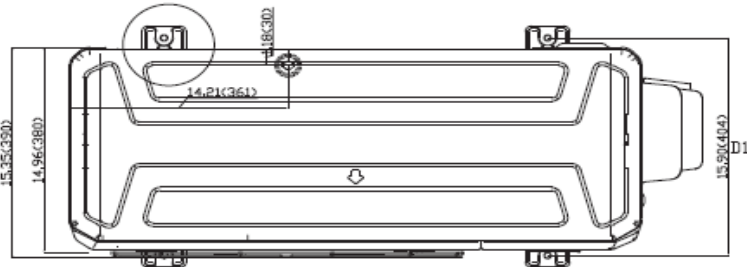
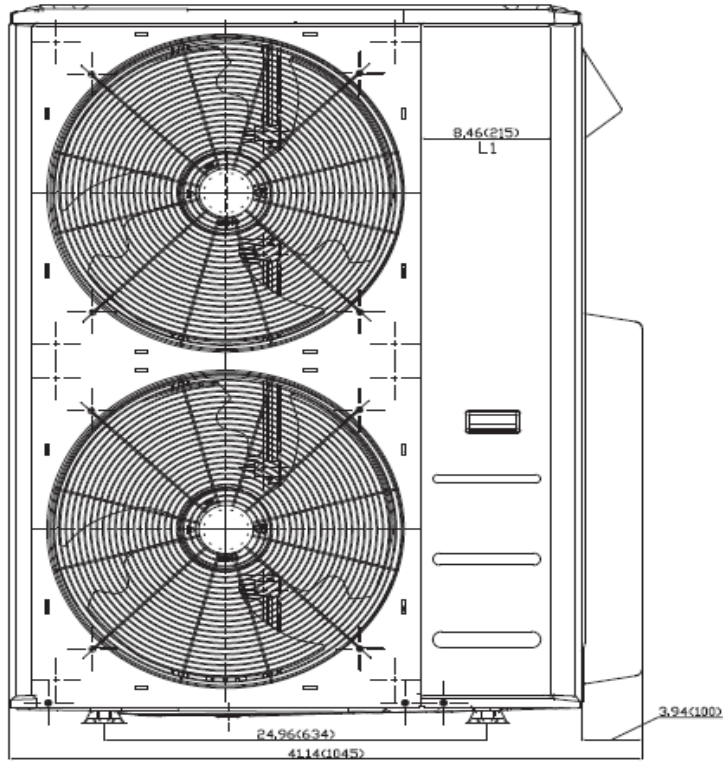
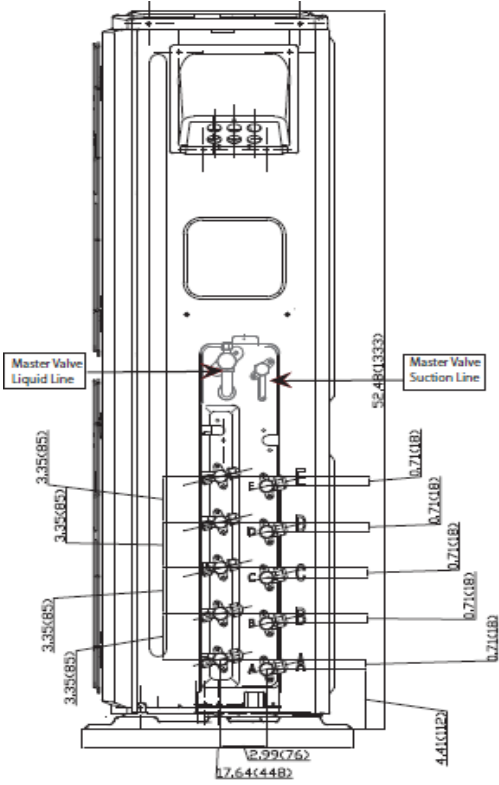

DETAIL .

