



# Service Manual

## FAN COIL UNITS

Cancels: SM03-2

SM03-3  
3-97

### TABLE OF CONTENTS

	Page
<b>SAFETY CONSIDERATIONS</b> .....	1-3
<b>INTRODUCTION</b> .....	3
<b>UNIT IDENTIFICATION</b> .....	2-3
<b>PRODUCT OFFERING</b> .....	3
<b>FAN MOTOR SPEED TAPS</b> .....	3
<b>FA4A, FB4A, FC4B, AND FH4A CIRCUIT BOARD FUNCTION AND TROUBLESHOOTING - CES013003-00 and -01 PCB</b> .....	3-6
• Printed Circuit Board (PCB) Component Layout and Description	
• Unit Functions	
• Troubleshooting PCB	
<b>CIRCUIT BOARD FUNCTION AND TROUBLESHOOTING — HK61GA001 AND HK61GA003 CIRCUIT BOARDS</b> .....	6-16
• Printed Circuit Board (PCB) Component Layout and Description	
• PCB Component Functions	
• Troubleshooting PCB	
<b>ELECTRIC HEATER FUNCTION AND TROUBLESHOOTING</b> .....	16-18
• Description of Electric Heater Components	
• Troubleshooting KFA and KFB Series Electric Heaters	
<b>FAN COIL DESCRIPTION AND TROUBLESHOOTING — FK4B</b> .....	18-26
• Integrated Controls and Motor (ICM2)	
• PCB Layout and Description	
• Sequence of Operation	
• Easy Select Configuration Taps	
• Troubleshooting PCB	
• Troubleshooting ICM2	
• Condensed Version of Troubleshooting FK4B Motor and Controls	
• Accessories	
<b>FAN COIL DESCRIPTION AND TROUBLESHOOTING — FK4C</b> .....	26-32
• Integrated Controls and Motor (ICM2)	
• PCB Layout and Description	
• Sequence of Operation	
• Easy Select Configuration Taps	
• Troubleshooting PCB	
• Troubleshooting ICM2	
• Condensed Version of Troubleshooting FK4C Motor and Controls	
• Accessories	
<b>THERMOSTATIC EXPANSION VALVES (TXV)</b> .....	32-33
• Problems Affecting TXV	
<b>PISTON BODY CLEANING OR REPLACEMENT</b> .....	33-34
<b>LIQUID TUBE STRAINER</b> .....	34
<b>COIL/CONDENSATE PAN REMOVAL AND REPLACEMENT</b> .....	34-35
• A-Coil Units	
• Slope Coil Units	
<b>CARE AND MAINTENANCE</b> .....	35-36
• Filter Assembly	
• Cooling Coil, Drain Pan, and Condensate Drain	

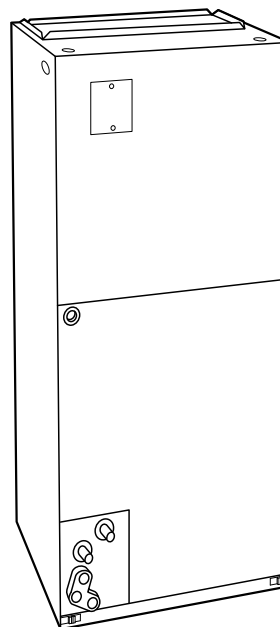

A95518

**Fig. 1—Typical Fan Coil**

• Blower Motor and Wheel	
<b>FF1A/FF1B/FF1C SERVICE AND TROUBLESHOOTING</b> .....	36-39
• Fan Motor	
• Electric Heater Service	
• Cleaning or Replacing Refrigerant Flow-Control Device	
• Liquid Tube Strainer	
• Sequence of Operation	
• Care and Maintenance	
<b>FD3A SERVICE AND TROUBLESHOOTING</b> .....	39-41
• Fan Motor	
• Electric Heater Service	
• Cleaning or Replacing Refrigerant Flow-Control Device	
• Liquid Tube Strainer	
• Care and Maintenance	
<b>FG3A SERVICE AND TROUBLESHOOTING</b> .....	41-42
• Service	
• Maintenance	
<b>FA4A, FB4A, AND FC4B SMART HEAT CIRCUIT BOARD FUNCTION AND TROUBLESHOOTING</b> .....	42-47
• PCB Component Layout, Description, and Function	
• Unit Functions	
• Smart Heat Operation	
• Electrical Operating Sequences and Troubleshooting	

### SAFETY CONSIDERATIONS

Improper installation, adjustment, alteration, service, maintenance, or use can cause explosion, fire, electrical shock, or other conditions which may cause personal injury or property damage. Consult a qualified installer, service agency, or your distributor or branch for information or assistance. The qualified installer or

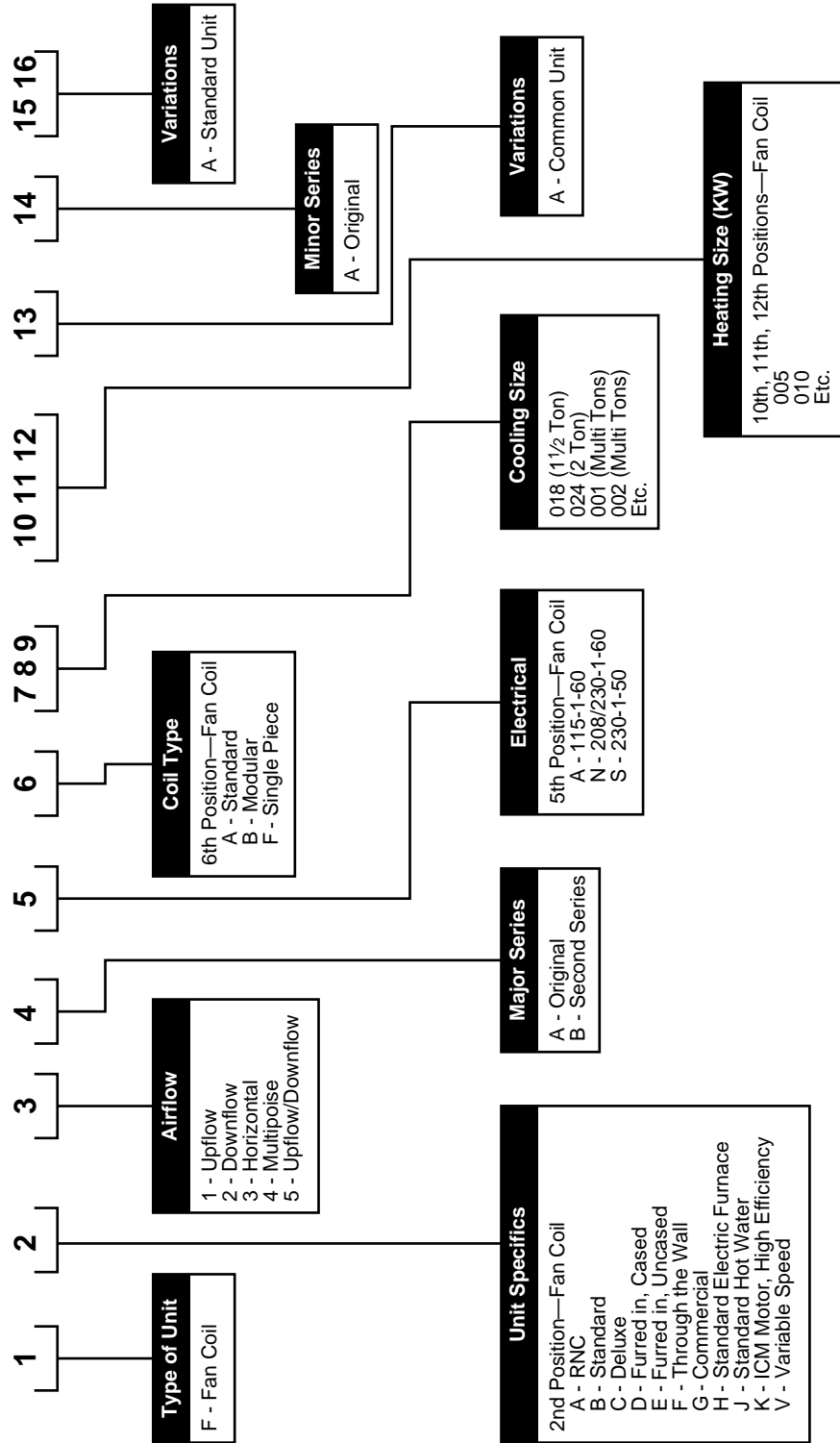

A94344

Fig. 2—Fan Coil 16-Position Numbering System

**TABLE 1—PRODUCT OFFERING**

MODEL	UNIT SIZE	DESCRIPTION	CABINET
FA4ANF	018-060	Multipoise	Single Piece
FB4ANB	042-070	Multipoise	Modular
FB4ANF	018-060	Multipoise	Single Piece
FB4ASB	042-060	Multipoise 50 Hz	Modular
FB4ASF	018-060	Multipoise 50 Hz	Single Piece
FC4BNB	042-070	Multipoise	Modular
FC4BNF	024-060	Multipoise	Single Piece
FD3ANA	018-030	Horizontal	Single Piece
FF1A/FF1BNA/FF1C	018-030	Vertical	Single Piece
FG3ANA	024, 036, 048, 060	Horizontal/Small Commercial	Single Piece
FH4ANB	003, 004	Multipoise	Modular
FH4ANF	001-004	Multipoise	Single Piece
FK4CNB	006	Multipoise	Modular
FK4CNF	001-005	Multipoise	Single Piece

**NOTE:** Multipoise units are approved for upflow, downflow, and horizontal left and right applications.

**TABLE 2—FAN MOTOR SPEED TAPS**

MODEL	UNIT SIZE	NUMBER OF SPEEDS	HIGH SPEED	MEDIUM SPEED	LOW SPEED	COMMON
FA4A	018-036	2	Black	—	Blue	Yellow
FA4A	042-060	3	Black	Blue	Red	Yellow
FB4A	018-070	3	Black	Blue	Red	Yellow
FC4B	024-070	3	Black	Blue	Red	Yellow
FD3A	018-030	2	Black	—	Red	Yellow
FF1A/FF1B/FF1C	018-030	2	Black	—	Red	Violet
FG3A	024, 036, 048, 060	1*	—	—	—	—
FH4A	001-004	3	Black	Blue	Red	Yellow

\*Belt drive.

agency must use factory-authorized kits or accessories when modifying this product. Refer to the individual installation instructions packaged with the kits or accessories for detailed information.

Follow all safety codes. Wear safety glasses and work gloves. Use quenching cloth for brazing operations. Have fire extinguisher available. Read these instructions thoroughly and follow all warnings or cautions attached to the unit. Consult local building codes and National Electrical Code (NEC) for special installation requirements.

It is important to recognize safety information. This is the safety-alert symbol . When you see this symbol on the unit or in instructions and manuals, be alert to the potential for personal injury.

Understand the signal words DANGER, WARNING, and CAUTION. These words are used with the safety-alert symbol. DANGER identifies the most serious hazards which **will** result in severe personal injury or death. WARNING signifies hazards which **could** result in personal injury or death. CAUTION is used to identify unsafe practices which **would** result in minor personal injury or product and property damage.

**INTRODUCTION**

The "F" series fan coil units are designed for flexibility in a variety of applications, meeting upflow, horizontal, or downflow requirements. Units are available in 1-1/2 through 5 ton nominal cooling capacities. Factory-authorized, field-installed electric heater packages are available in 3 through 30 kilowatts.

	<b>WARNING:</b> Before installing or servicing fan coil, always turn off all power to unit. There may be more than 1 disconnect switch. Turn off accessory heater power if applicable. Electrical shock can cause personal injury or death.
---	---

**UNIT IDENTIFICATION**

The 16 position numbering chart allows identification of all available fan coil units. (See Fig. 2.)

**FA4A, FB4A, FC4B, AND FH4A CIRCUIT BOARD FUNCTION AND TROUBLESHOOTING**

**CES0130003-00 and -01 PCB**

This section of the service manual describes the CES0130003-00 and -01 PCB by examining the functional operation of the PCB components.

**I. PRINTED CIRCUIT BOARD (PCB) COMPONENT LAYOUT AND DESCRIPTION**

Layout of the actual PCB is depicted in Fig. 3.

1. The low-voltage stripped leads are used to connect the 24-v side of transformer to indoor thermostat and outdoor section.
2. A 5-amp fuse is used to protect the low-voltage transformer secondary.
3. The fan relay is controlled by thermostat and turns fan on and off.
4. A plug is used as the connection for PCB power and electric heaters. Note the pin numbers on plug.

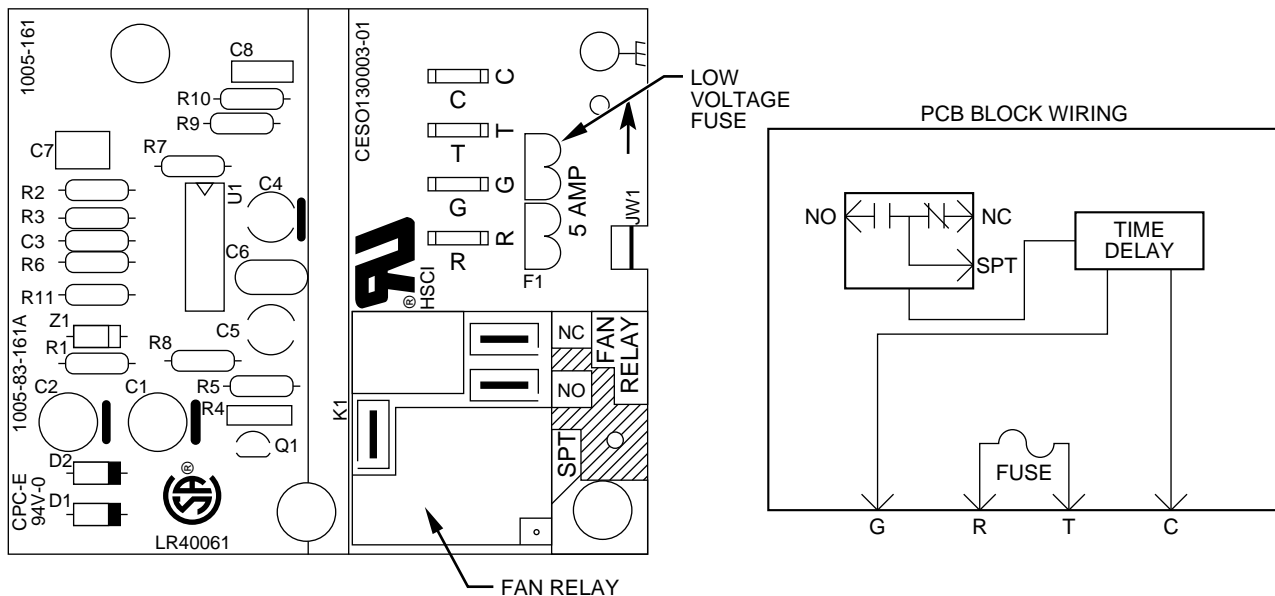

Fig. 3—Fan Coil Printed-Circuit Board

A97020

5. A time-delay relay circuit keeps fan motor running for 90 sec after G is de-energized.

## II. UNIT FUNCTIONS

### A. Transformer

1. Proper Wiring of Transformer Primary or High Side  
Yellow wire from Molex plug is wired to C terminal on transformer and black wire from PCB relay (normally-open) terminal is wired to 208V or 230V terminal on transformer. Units are factory wired at 230V terminal.
2. Proper Wiring of Transformer Secondary or 24-v Side  
Red wire of transformer is wired to T terminal on PCB and brown wire of transformer is wired to C terminal on PCB.

**NOTE:** T terminal on PCB is used to protect transformer. T terminal is connected through the fuse to R terminal on PCB.

### B. Indoor Fan

#### 1. Wiring

Indoor fan motor yellow lead is wired to C terminal on transformer. The red, blue, or black speed lead is wired to SPT terminal on fan relay part of PCB. Units are factory wired on medium speed (blue lead connected).

**NOTE:** Unused fan speed leads must be capped or taped off to prevent direct short to cabinet surface.

#### 2. Functional Control

##### a. Thermostat and Relay Control

When thermostat calls for the fan in cooling, heat pump, heating, or fan-only mode, a 24-vac signal is sent to relay. This causes the relay to close its normally-open contacts, turning on fan. When thermostat no longer calls for the fan, the signal sent to relay is turned off and relay opens causing fan to turn off after a 90-sec fan-off delay.

##### b. Sequencer Interlock

The fan will also operate whenever there is a call for electric heat, even if fan relay is not energized. This happens because fan is interlocked with first stage of electric heat through the normally-closed contact of fan relay.

**NOTE:** The fan interlock is only connected to first stage electric heat W2. W3 and E do not contain an interlock with fan. See outdoor thermostat Installation Instructions when electric heat staging is desired.

### C. Electric Heat

When thermostat calls for electric heat, a 24-vac signal is sent to PCB through W2, causing first stage to turn on. W3 and E also receive signal if wired in with W2. The signal sent to W2 causes first stage to turn on. If W3 and E are not wired to W2, the sequencers can be controlled individually to stage additional electric heat. The sequence control is described in the following section:

#### 1. W2

When thermostat sends a signal to W2, a 24-vac signal is applied across sequencer number 1, causing it to close after a short delay. When sequencer number 1 closes, first stage of electric heat is energized. In straight electric heat, fan is also energized through the normally-closed contacts of fan relay. In cooling, heat pump, or manual fan mode, fan will already be running since fan relay would have been energized. When thermostat stops calling for electric heat, the 24-vac signal to sequencer number 1 turns off and sequencer opens after a delay of 60 to 90 sec. When sequencer opens, first stage of heat turns off along with fan, providing thermostat is not calling for the fan.

#### 2. W3

When a signal is sent to W3, a 24-vac signal to sequencer number 2 causes sequencer to close, with second stage of electric heat turning on after a short delay. The 24-vac signal applied to sequencer number 1 causes fan to operate. Timing is such that sequencer number 1 will turn on before sequencer number 2. When signal to W3 is turned off, sequencer number 2 opens after a short delay. If W2 is also satisfied, first stage of electric heat and fan will also turn off, providing thermostat is not calling for the fan.

#### 3. E

When thermostat sends a signal to E, a 24-vac signal is sent to sequencer number 3. The 24-vac signal applied to sequencer number 3 turns on third stage of electric heat. The 24-vac signal applied to sequencer number 1 turns on first stage of electric heat and fan. When thermostat stops calling for electric heat, the signal to sequencers 1, 2, and 3 are turned off, and sequencers open. This causes electric heat to turn off with fan providing thermostat is not calling for the fan.

**NOTE:** Electric heaters are factory wired with all stages tied together. If independent staging is desired, consult outdoor thermostat Installation Instructions.

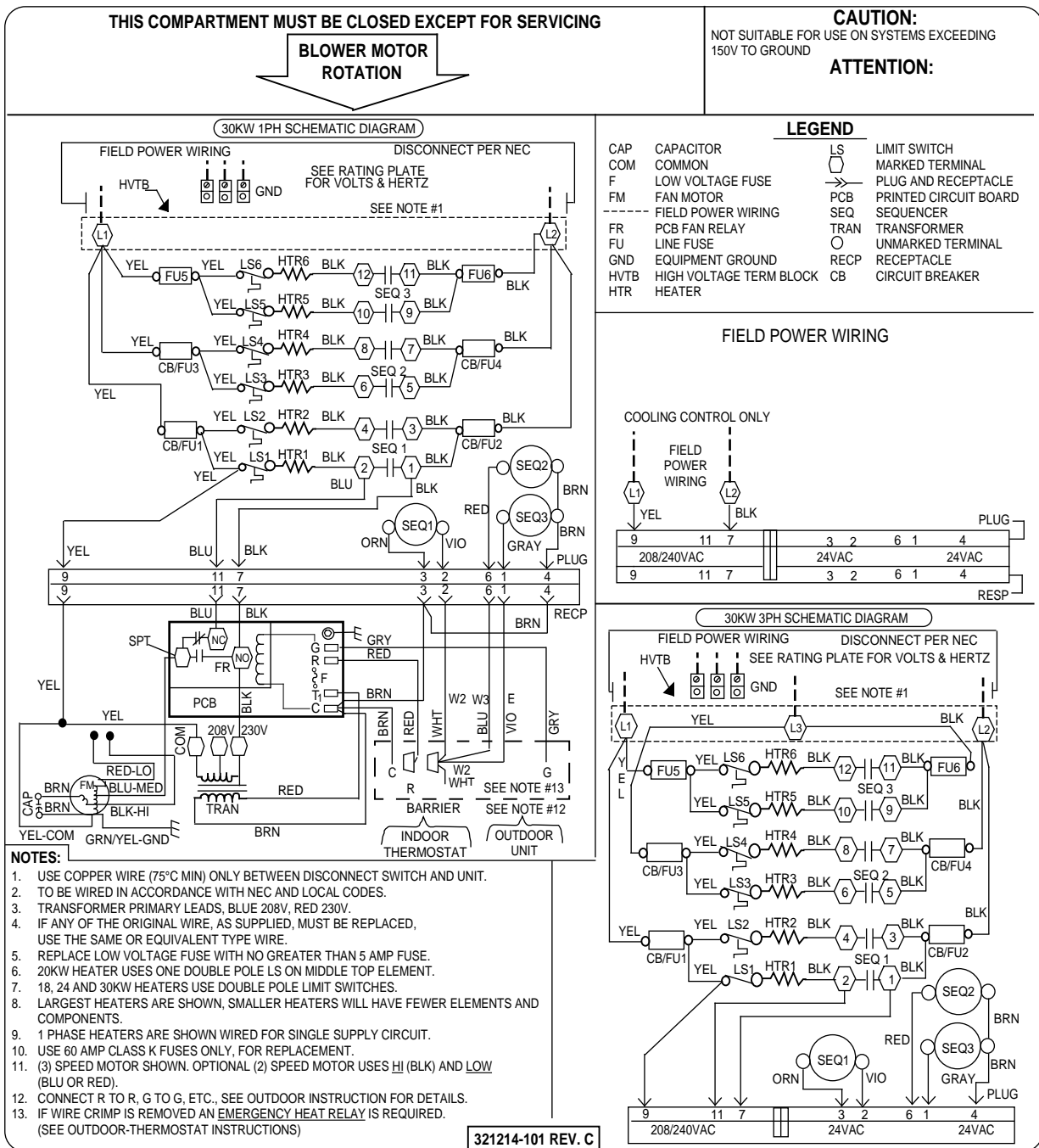

**Fig. 4—Wiring Diagram**

A94346

**III. TROUBLESHOOTING THE PRINTED-CIRCUIT BOARD**

Use wiring schematic shown in Fig. 4 as a guide in troubleshooting PCB unless otherwise noted.

**A. If Fan Will Not Turn On from Thermostat:**

**IF THERE IS NO HIGH VOLTAGE TO PCB:**

1. Check plug/receptacle connection. This supplies power from heaters to PCB. Be sure plug is connected properly.
2. Check sequencer number 1 and plug wiring. Yellow wire should be connected to pin number 9 of plug and to limit switch. Black wire should be connected to pin number 7 of plug and to sequencer number 1.

3. Check power leads L1 and L2. If these are not receiving power, system cannot function.

**IF PCB HAS HIGH VOLTAGE APPLIED TO IT:**

1. Check low-voltage transformer leads R (red) and C (brown). Be sure they are wired to correct locations.
2. Check output voltage of transformer secondary side R (red) and C (brown). Be sure transformer output is between 18 and 30 vac. If transformer output is incorrect and transformer is receiving correct input voltage (208v or 230v), then transformer needs to be replaced with recommended transformer. If no problem exists with transformer secondary, proceed to items 3 and 4.

3. Check low-voltage fuse shown in Fig. 3. If fuse is blown, replace it. The transformer cannot supply power to board with fuse blown or loose. If fuse blows when unit has power applied to it, the system most likely has 1 of the following problems:
  - a. Check all 24-v wiring for an electrical short.
  - b. The maximum load on transformer is 40 va. If load on transformer is excessive, the low-voltage 5-amp fuse will blow to protect transformer. If load exceeds va rating of transformer, a larger va rated transformer needs to be installed. Check sequencers for excessive current draw.
  - c. Check wiring of heaters. If a heater is miswired, fuse may blow. If a heater is miswired, correct miswiring by comparing it to heater wiring label.
4. Check connections on primary side of transformer. If they are not connected properly, the low-voltage terminal board cannot supply the 24-v signal to energize fan relay. If transformer is receiving correct primary voltage but is not putting out correct secondary voltage, transformer needs to be replaced.

**B. If Electric Heat Stages Will Not Turn On But Fan Will Turn On:**

**IF THERE IS NO HIGH VOLTAGE TO PCB:**

1. Check plug connection between heaters and board. This supplies power to transformer and fan. Be sure plug is connected properly.
2. Check sequencer number 1 and plug wiring. Yellow wire should be connected to pin number 9 of plug and to limit switch. Black wire should be connected to pin number 7 of plug and to sequencer number 1.
3. Check incoming high-voltage power leads. If these are not receiving power, system cannot function.

**IF PCB HAS HIGH VOLTAGE APPLIED TO IT:**

1. Check low-voltage transformer leads R (red) and C (brown). Make sure they are wired to correct location. The unit will not function without proper connections.
2. Check output voltage of transformer secondary side R (red) and C (brown). If transformer output is low (less than 18 vac), refer to items 3 and 4 of previous If PCB Has High Voltage Applied To It section.

**IF TRACES ARE OVERHEATED ON BACK OF PCB:**

Usually whenever a trace is blown on PCB, it means either there has been a high-voltage short or high voltage has been applied to low-voltage circuit. This can be prevented by making sure PCB is wired correctly before PCB has power applied to it.

**C. If PCB Fuse Keeps Blowing:**

When low-voltage fuse blows, it means transformer would have blown if fuse had not been in circuit to protect it. The fuse usually blows when there is a high current draw on transformer, high voltage applied to low-voltage circuit, or a direct secondary short. When there is a high current draw on transformer, it is most likely because transformer has been shorted or system is trying to draw more va than transformer rating allows. When fuse blows because of high voltage, the system has mixed high- and low-voltage signals.

1. Check wiring of sequencers as shown in Fig. 4. Be sure transformer is not shorting out because thermostat wires are miswired.
2. Check wiring of sequencers as shown in Fig. 4. Be sure low-voltage and high-voltage wiring is connected to proper sequencers.

3. Check va draw on transformer. If va draw is more than va rating of transformer, fuse will blow. If this is the case, replace transformer with one that has a higher va rating and meets system specifications.

**D. If Fan Runs Continuously:**

1. If PCB has no low-voltage power, check blue and black fan leads. These may be switched at sequencer.
2. If PCB has low-voltage power, check fan relay to see if it is opening and closing. It may be stuck in the normally-closed position due to debris in relay.

**E. Transformer Failure:**

1. Check 208-v and 230-v transformer connections. They may be miswired.

**CIRCUIT BOARD FUNCTION AND TROUBLESHOOTING  
HK61GA001 and HK61GA003 Circuit Boards**

This section of the service manual describes the HK61GA001 and HK61GA003 printed-circuit boards (PCB) by examining the functional operation of the printed-circuit board's components.

**I. PCB COMPONENT LAYOUT AND DESCRIPTION**

Layout of the actual printed-circuit boards are depicted in Fig. 5 and Fig. 6.

1. The low-voltage terminal board is used to connect the indoor thermostat to the low, 24-v side of the transformer, and to serve as a junction between the indoor thermostat and the outdoor section.
  2. Break off the tabs.
    - a. W2-3 — Used to control (stage) the second stage of electric heat. The first stage controlling electric heat and the indoor fan are interlocked through diodes.
    - b. W2-E — Used to control (stage) the third stage of electric heat.
3. A fuse is used to protect the low-voltage transformer.
4. AUX 1 and AUX 2 are connections for the latent capacity control, delay off kit, 2-speed kit and air conditioning accessories.
5. F1, F2, F3, and F4 are connections for the indoor fan.
6. EAC1 and EAC2 are 240-v connections, which parallel fan lead connections, for the electronic air cleaner.
7. L1 and L2 are 240-v connections which parallel power input.
8. T1, T2 and T3 are connections for the primary, high-voltage side of the transformer.
9. The fan relay is controlled by the thermostat and turns the fan on and off.
10. A plug is used as the connection for the PCB power and electric heaters. Note the pin numbers on the plug.
11. Diodes provide DC power for the fan relay and the first stage of electric heat: W2, W3 or E.

**II. PCB COMPONENT FUNCTIONS**

**A. Low-Voltage Terminal Board**

The low-voltage terminal board connects the indoor thermostat to the outdoor unit as shown in Fig. 7. The terminals are listed as follows along with their functional control.

1. R is used to connect the secondary side of the transformer. The red wire provides low voltage (24v) to the PCB and the thermostat. R is fused on the HK61GA003 board.

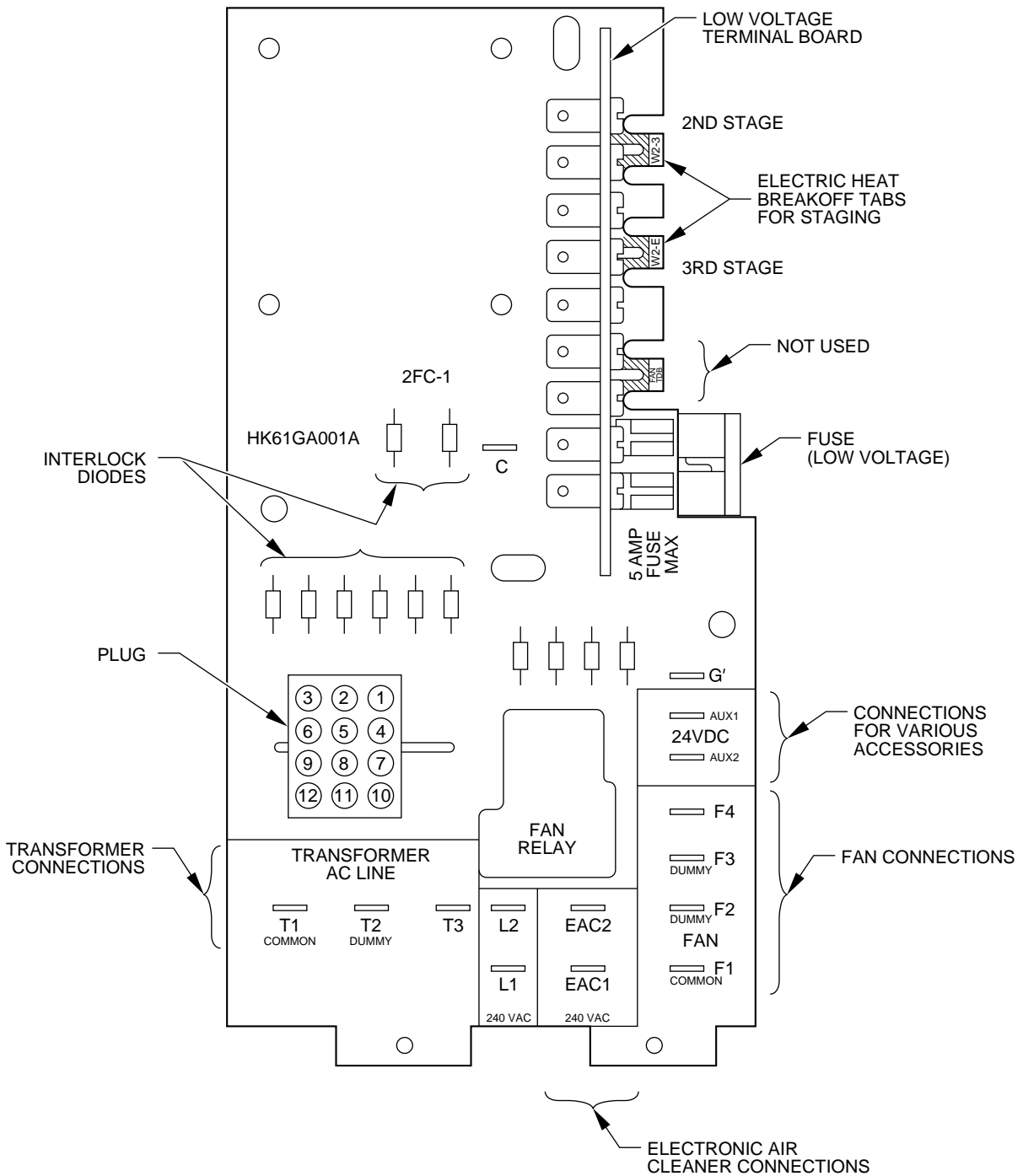
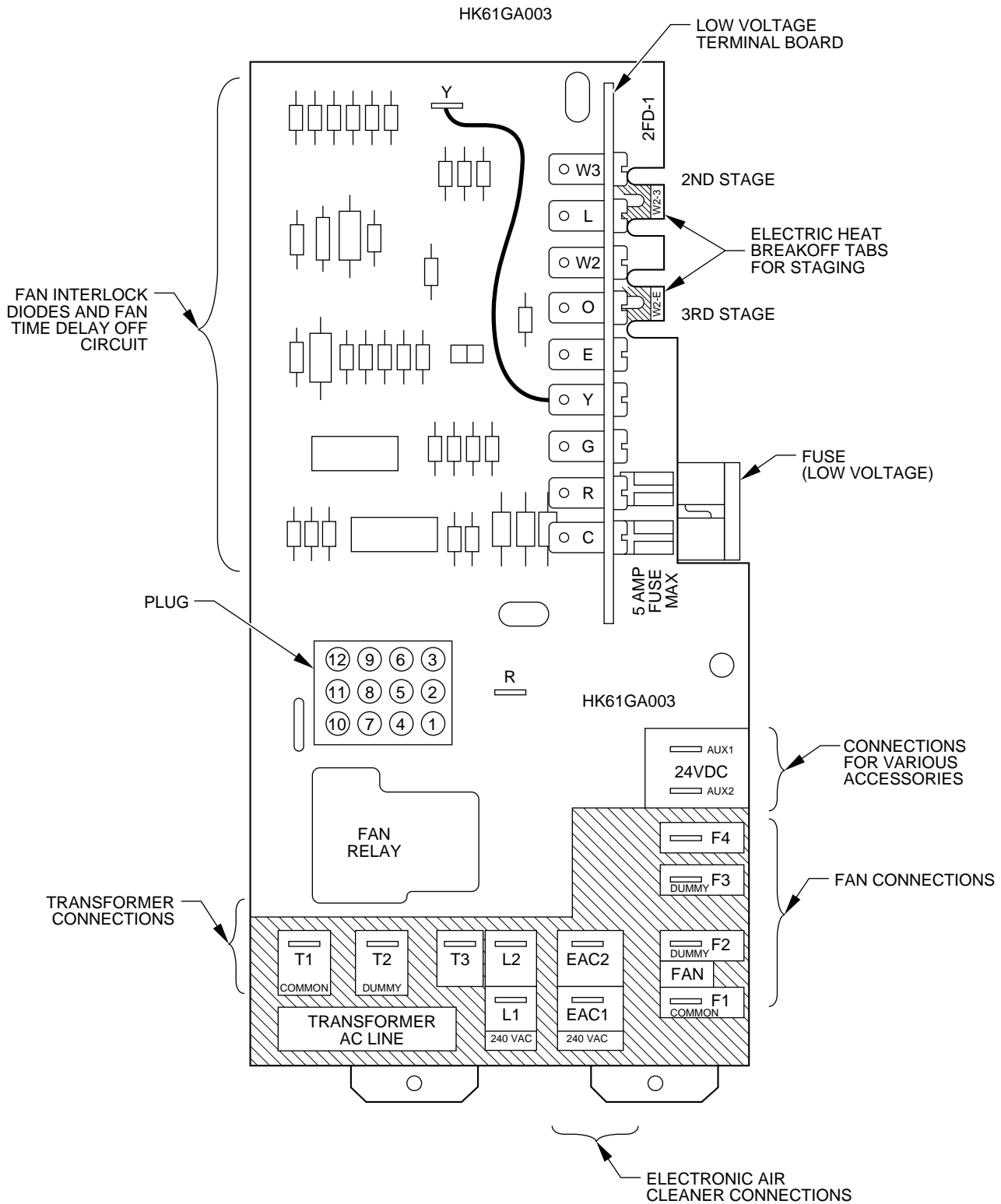

Fig. 5—HK61GA001 Printed-Circuit Board

A97025

2. C is used to connect the brown wire of the thermostat to provide a return path to ground through the fuse which protects the transformer. C is fused on the HK61GA001 board.
3. G is used to control the switching of the relay to turn the fan on through the normally open contact of the relay.
4. Y on the HK61GA001 is used as the junction for the outdoor section's Y connection which controls the compressor contactor for heat pump and cooling modes. The HK61GA003 board contains a 90-sec fan-off delay which begins timing when the Y is de-energized.
5. O is used as a junction for a heat pump reversing valve circuit.
6. W2 is used to turn on the first stage of electric heat which is interlocked with the fan through the normally closed fan relay. Unless the tabs are broken off, all stages of electric heat will turn on when W2 receives a signal from the thermostat.
7. W3 is used to turn on the second stage of electric heat. Note the W2 and W3 tab must be broken off for individual staging to take place. Energizing W3 will always turn on the first stage through the diodes even if the tabs are broken off.



**Fig. 6—HK61GA003 Printed-Circuit Board**

A97026

8. E is used to turn on the third stage of electric heat. Note that the W3 and E tab must be broken for this individual staging. Energizing E will always turn on the first stage through the diodes even if the tab is broken off.

9. L is used as a junction to wire a diagnostic light (LED) on selected thermostats.

**B. Transformer**

The proper wiring of the transformer on the HK61GA001 board is illustrated in Fig. 7. Note that T1, T2, and T3 are wired to the

primary or high side of the transformer. The blue wire is connected to T3 for 208-v applications. The red wire is connected to T3 for 230-v applications. Units are factory wired at 230v. The T2 terminal is a dummy.

**C. Indoor Fan**

1. Wiring--The fan connects to F1, F2, F3, and F4 as shown in Fig. 7. Note that F2 and F3 are dummy terminals. The desired fan speed is connected to F4 and the common is connected to F1. Units are factory wired at medium speed.



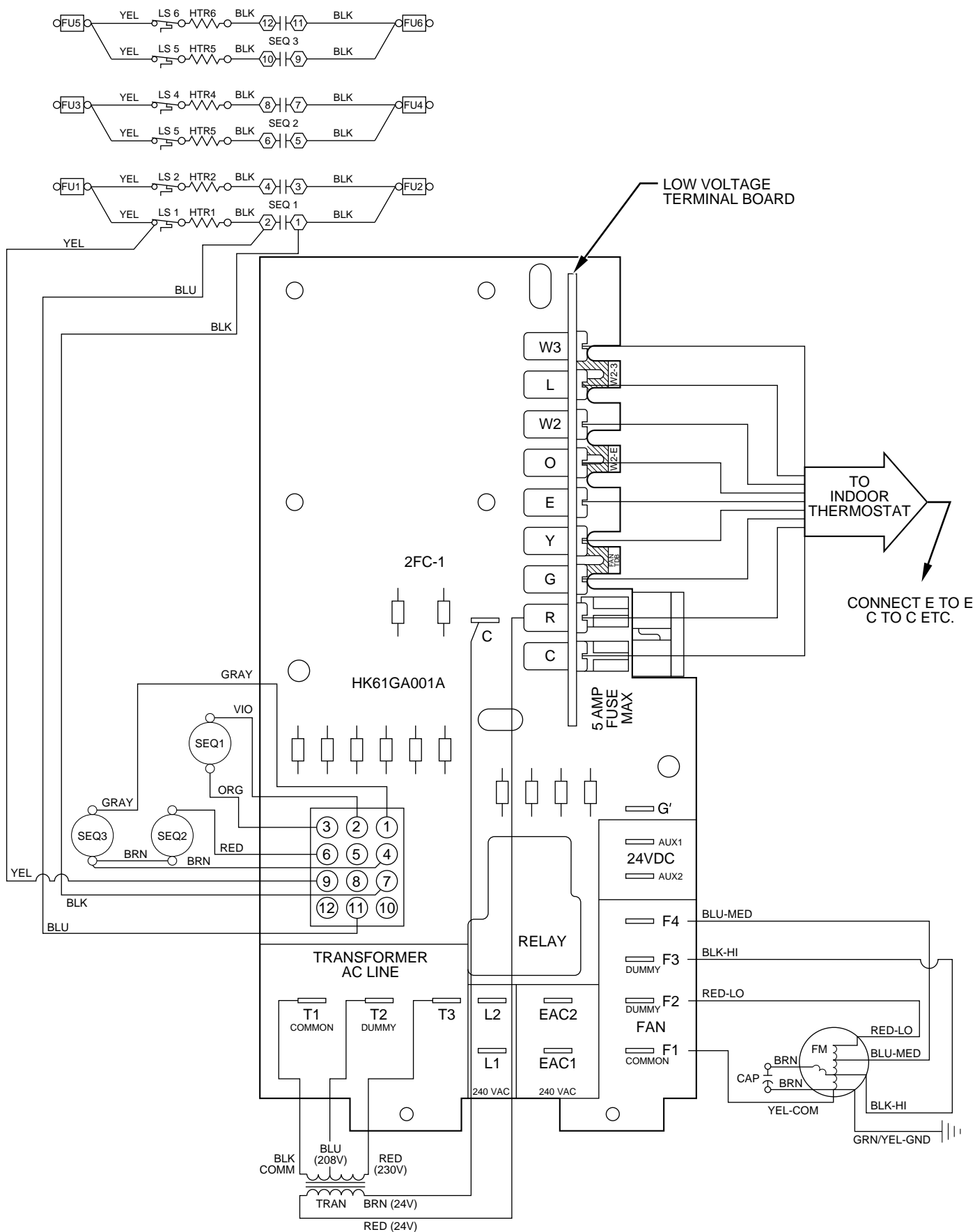

Fig. 7—10kw to 20kw Circuits

## 2. Functional Control

- a. Thermostat and Relay Control--When the thermostat calls for the fan in cooling, heat pump, electric heat, or fan-only mode, a **24-v dc** signal is sent to the relay. This causes the relay to close its normally open contacts, thus turning on the fan. When the thermostat no longer calls for the fan, the signal sent to the relay is turned off and the relay opens causing the fan to turn off. The HK61GA003 board contains a 90-sec fan-off delay when Y is de-energized.
- b. Sequencer Interlock--The fan will also turn on whenever there is any call for electric heat, even if the fan relay is not energized. This happens because the fan is interlocked with the first stage of electric heat through the normally closed contact of the fan relay.

## D. Electric Heat

When the thermostat calls for electric heat, a 24-v signal is sent to the PCB through W2, causing the first stage to turn on. W3 and E also receive the signal if the tabs are not broken off the PCB. The signal sent to W2 causes the first stage to turn on. If the tabs are broken off the PCB, the sequencers can be controlled individually to stage the electric heat. The sequence control is described in the following section:

1. W2--When the thermostat sends a signal to W2, a 24-v dc signal is applied across sequencer number 1, causing it to close. When sequencer number 1 closes, the first stage of electric heat energizes after a short delay. In straight electric heat, the fan is also energized through the normally closed contacts of the fan relay. In cooling, heat pump, or manual fan mode, the fan will already be running since the fan relay would have been energized. When the thermostat stops calling for electric heat, the 24-v dc signal to sequencer number 1 turns off and the sequencer opens after a delay of 60 to 90 sec. When the sequencer opens, the first stage of heat turns off along with the fan, providing that the thermostat is not calling for the fan. Note that the electric heat cannot be turned on without the fan being turned on at the same time. This is a fan interlock system.
2. W3--When a signal is sent to W3, 2 control signals are sent out to the sequencers; a 24-v dc signal to sequencer number 1 through the diode interlock, and a 24-v ac signal to sequencer number 2. The 24-v ac signal applied to sequence number 2 causes the sequencer to close, with the second stage of electric heat turning on after a short delay.

The 24-v dc signal applied to sequencer number 1 causes the first stage of electric heat to turn on in the same manner as described in W2 above. Note that W3 is interlocked with the fan, since sequence

number 1 is turned on whenever W3 has a signal sent to it. Timing is such that sequence number 1 will turn on before sequence number 2. When the signal to W3 is turned off, sequencer number 2 opens after a short delay. If W2 is also satisfied, the first stage of electric heat and the fan will also turn off, providing the thermostat is not calling for the fan to be on.

E--When the thermostat sends a signal to E 2 signals are sent out to the sequencers. A 24-v ac signal is sent to sequencer number 3 and a 24-v dc signal is sent to sequencer number 1. The 24-v ac signal applied to sequencer number 3 turns on the third stage of electric

heat. The 24-v dc signal applied to sequencer 1 turns on the first stage of electric heat and the fan in the same manner as W3. Note that E is also interlocked with the fan.

When the thermostat stops calling for electric heat, the signals to sequencers 1 and 3 are turned off and the sequencers open. This causes the electric heat to turn off with the fan if the thermostat is not calling for the fan.

## E. Accessories

1. EAC1 and EAC2 for Electronic Air Cleaners
  - a. There are 240-v electronic air cleaner contacts provided at EAC1 and EAC2. The electronic air cleaner is connected in parallel with the fan so that it is on whenever the fan is on. A 120-v installation is similar in function but connected between EAC2 and neutral of 230-v: 120-v transformer connected to EAC1 and EAC2. Refer to electronic air cleaner literature for further information.
2. AUX1 and AUX2 for 2-Speed Fan Relay Kit
  - a. Use to control fan speed operation, high speed for cooling, heat pump, and fan-only modes. Low speed is used for electric heat. Fig. 8 shows proper connection for 24-v dc 2-speed fan relay kit. Note that kit's relay coil is in parallel with fan relay coil on PCB connected to AUX1 and AUX2. Make sure the normally closed contact is connected to the lower speed.
  - b. The latent capacity control kit is used to control fan speed operation when the relative humidity is above a set point on humidistat. Humidistat opens and 2-speed fan relay remains in normally closed position with fan motor running at a lower speed for maximum humidity control. Fig. 9 shows proper connection for latent capacity control kit. Note that it is connected in the same manner as 2-speed fan relay kit but with relay connected to humidistat (orange wires).
  - c. Time delay-off relay kit is used to increase the efficiency of the system by delaying the fan from turning off after the thermostat is satisfied on the HK61GA001 board. The HK61GA003 board has this feature as standard. The proper wiring and mounting of the time delay-off relay kit is shown in Fig. 10.
  - d. Latent capacity control and time delay-off connections are shown in Fig. 11, for the HK61GA001 board only.

## III. TROUBLESHOOTING THE PRINTED-CIRCUIT BOARD

Use Fig. 12 wiring schematic as a guide in troubleshooting the PCB unless otherwise noted.

### A. If the fan will not turn on from the thermostat:

IF THERE IS NO HIGH VOLTAGE TO THE PCB:

1. Check the plug/receptacle connection; this brings power to the PCB. Make sure the plug is connected properly.
2. Check sequencer number 1 and the plug's wiring; the yellow wire should be connected to pin number 9 of the plug and the limit switch. A black wire should be connected to pin number 7 of the plug and to sequencer number 1.
3. Check power leads L1 and L2. If these are not receiving power, the system cannot function.

IF THE PCB HAS HIGH VOLTAGE APPLIED TO IT:

1. Check the low-voltage transformer leads, R and C. Make sure they are wired to the correct locations. Note that Fig. 12 shows wiring of the HK61GA001 board.
2. Check the output voltage of the secondary side, R and C, of the transformer. If the circuit board is a HK61GA003, make sure the ground strap is in place from C to the bracket. This strap must be in place to complete the 24-v circuit. Make sure the transformer output is around 24-v ac. If the transformer output is zero-v ac and the transformer is receiving the correct input voltage (208-v or 240-v), then the transformer needs to be replaced with the recommended transformer. If the transformer output is 24-v ac, then proceed to 3 and 4.

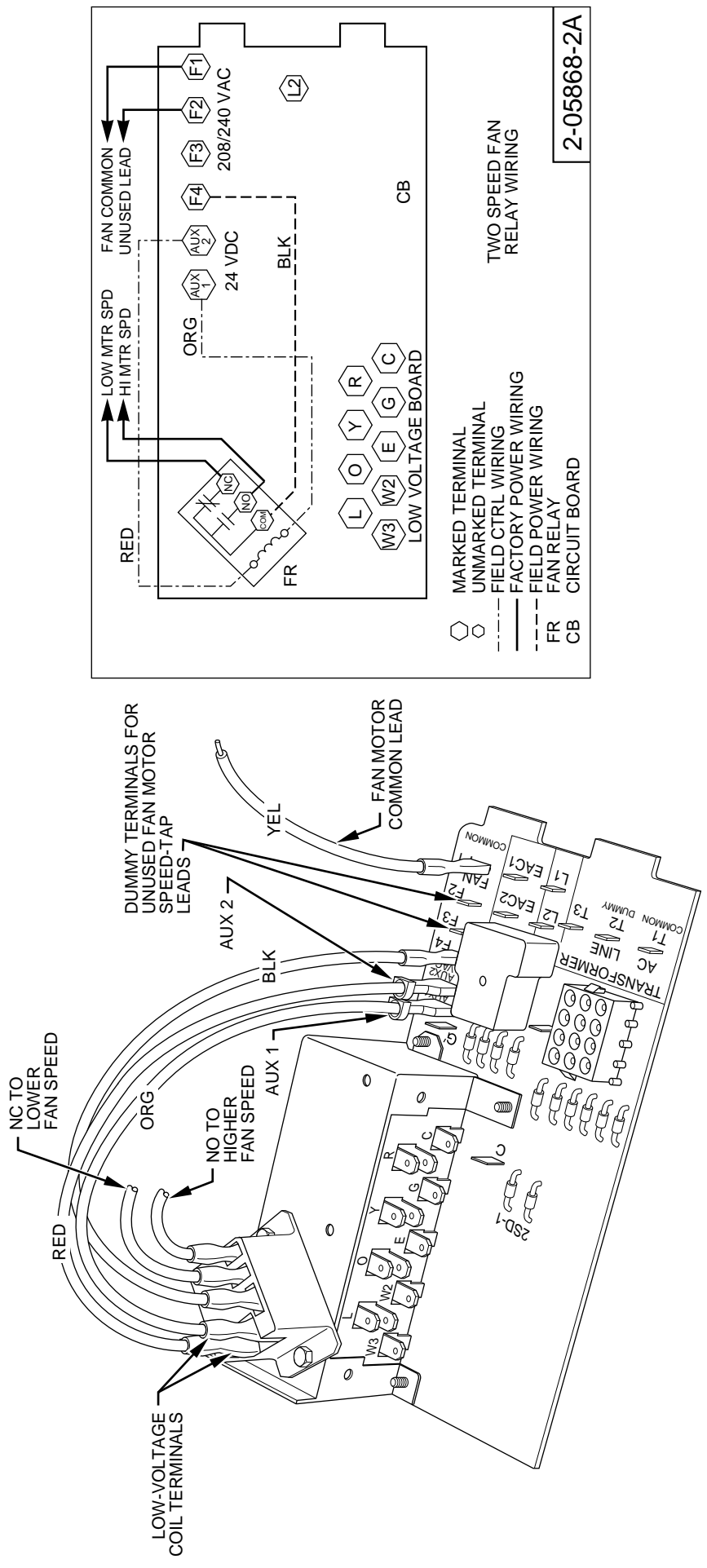
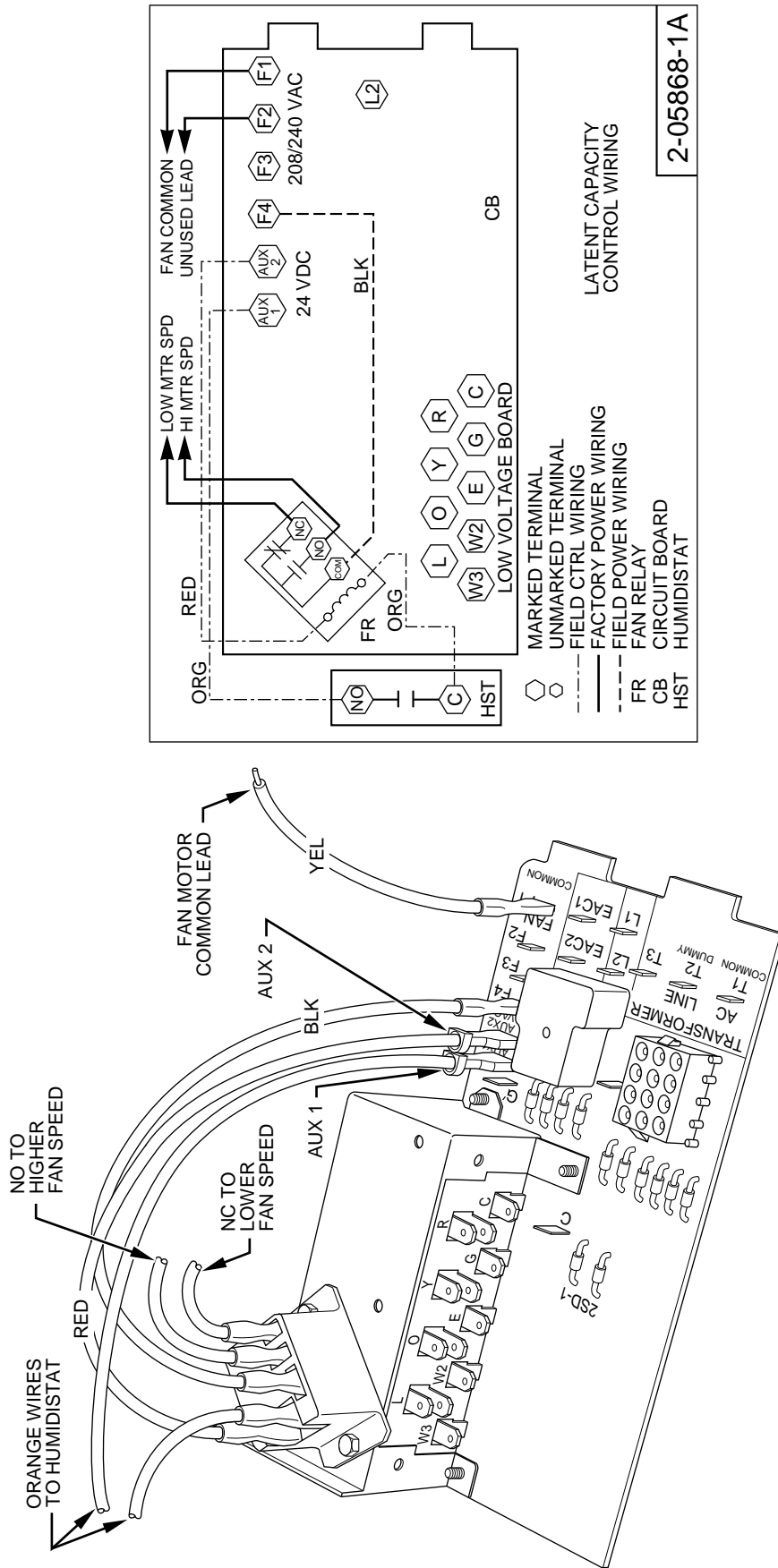

Fig. 8—Two-Speed Fan Relay Kit

A97028



A97029

Fig. 9—Latent Capacity Control Kit

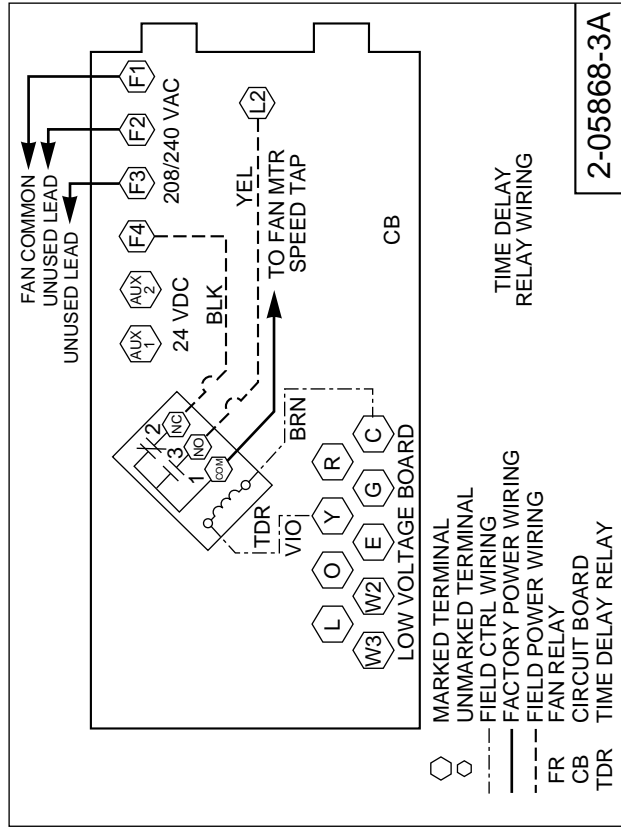
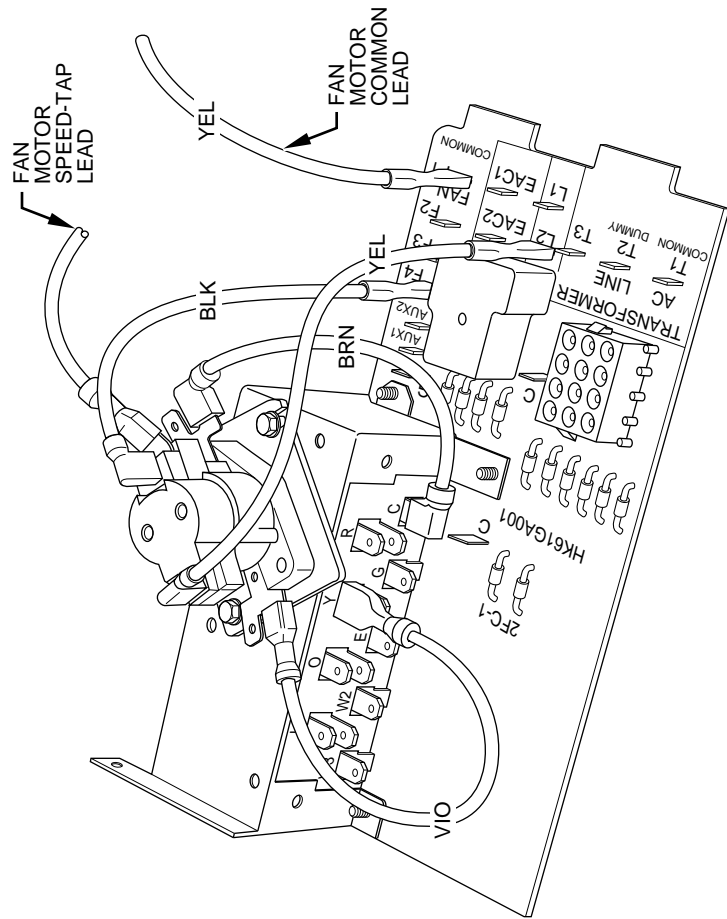

A97030

Fig. 10—Time Delay-Off Relay Kit

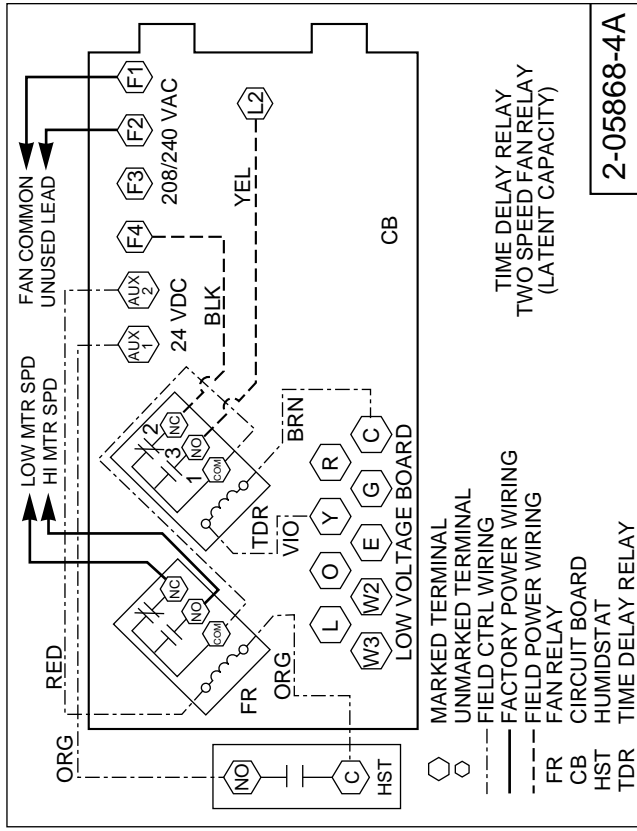
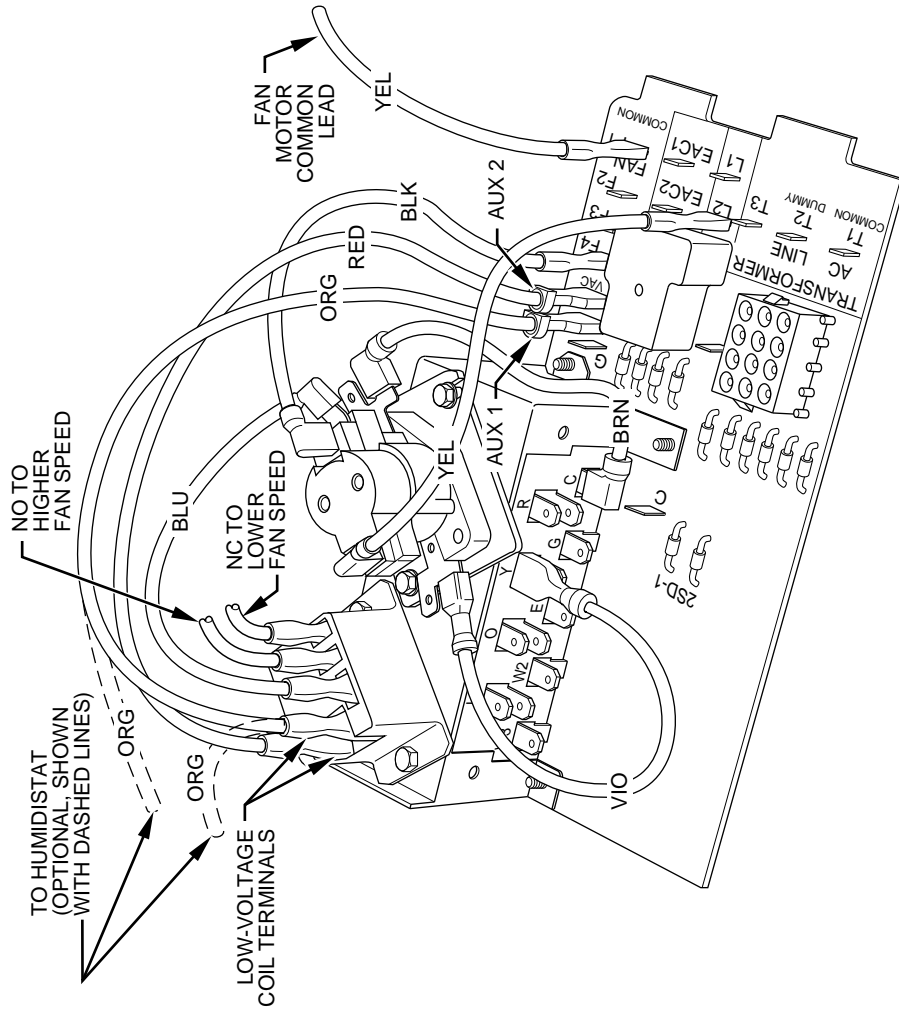

Fig. 11—Latent Capacity Control and Time Delay-Off Relay Kits

A97031

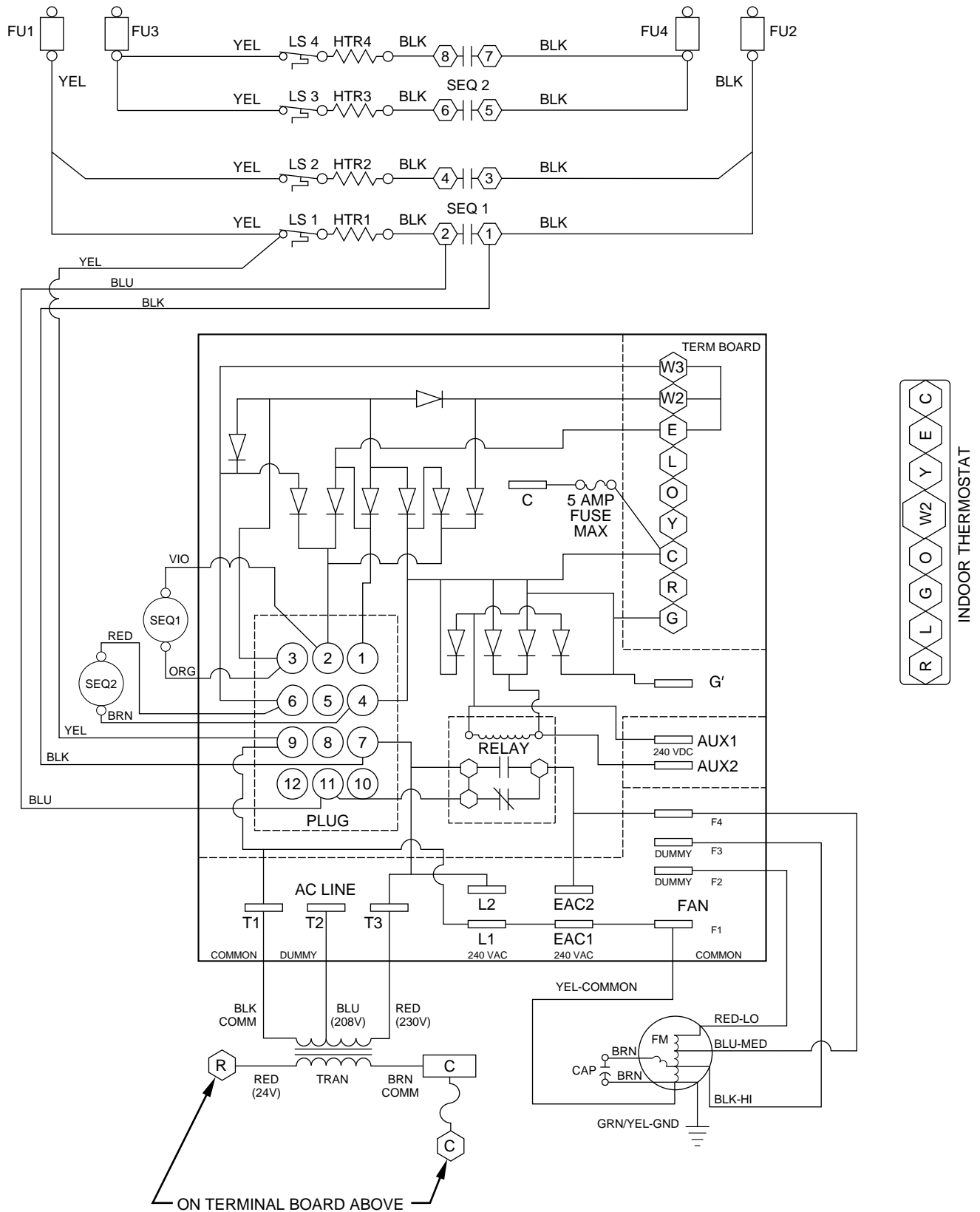

Fig. 12—Wiring Schematic

3. Check the low-voltage fuse shown in Fig. 5 and Fig. 6. If the fuse is blown, replace it. The transformer cannot supply power to the board with the fuse blown or loose. If the fuse blows when the unit has power applied to it, the system most likely has 1 of the following problems:
  - a. If the transformer is shorting out, check the wiring of the transformer.
  - b. The maximum load on the transformer is 40 va. If the load on the transformer is excessive, the low-voltage, 5-amp fuse will blow to protect the transformer. If the load exceeds the va rating of the transformer, a larger va rated transformer needs to be installed. Check the sequencers for excessive current draw.
  - c. Check the wiring of the heaters. If the heater is miswired, the fuse may blow. Check the diodes shown in Fig. 13 for signs of overheating. If the heater is miswired, correct the miswiring.
4. Check the T1, T2, and T3 connections on the primary side of the transformer. If they are not connected properly, the low-voltage terminal board cannot supply the 24-v signal to energize the fan relay. If the transformer is receiving the correct primary voltage but is not outputting the correct secondary voltage, the transformer needs to be replaced.

**B. If the electric heat stages will not turn on but the fan will turn on:**

1. Check the wiring of the sequencer. Pay particular attention to the high and low-voltage wiring of the sequencers.
2. Check the plug wiring to make sure that it is wired correctly.
3. Check the voltage to the sequencer; sequencer number 1 receives a 24-vac signal. If it is receiving the correct voltage, check to see if the sequencer is closing. If the sequencer is not closing but is receiving the correct voltage, replace the sequencer. If the sequencer is closing, check the high-voltage wiring as discussed in 1 and 2.

**C. If the electric heat and the fan will not turn on:**

**IF THERE IS NO HIGH VOLTAGE TO THE PCB:**

1. Check the plug connection. This brings power to the PCB transformer and the fan. Make sure the plug is connected properly.
2. Check sequencer number 1 and the plug wiring. The yellow wire should be connected to pin number 9 of the plug and the limit switch. The black wire should be connected to pin number 7 of the plug and to sequencer number 1.
3. Check incoming high-voltage power leads. If these are not receiving power, the system cannot function.

**IF THE PCB HAS HIGH-VOLTAGE APPLIED TO IT:**

1. Check the low-voltage transformer leads, R and C. Make sure they are wired to the correct location. The unit will not function without proper connections.
2. Check the output voltage of the secondary side, R and C, of the transformer. If the circuit board is an HK61GA003, make sure the ground strap is in place from C to the bracket. This strap must be in place to complete the 24-v circuit. If the transformer output is zero-v ac, refer to "If the PCB has high voltage applied to it" in column 1, numbers 3 and 4.

**D. If the traces are burnt off the back of the PCB:**

Usually whenever there is a trace blown on the PCB it means either there has been a high-voltage short or high voltage has been applied to the low-voltage circuit. This can be prevented by making sure the PCB is wired correctly before the PCB has power applied to it.

**E. If there are blown diodes:**

1. If diodes a and b are blown, it is probable the electric heater plug was miswired. Correct the miswiring. It should be noted the board will need to be replaced if the diode indicated is bad.
2. If any of the c diodes are blown, the fan is miswired to 1 of the low-voltage terminals, AUX1 or AUX2. Check to make sure that the fan leads are connected to the proper terminals as shown in Fig. 12. If the fan is connected properly, make sure that no other high voltage is applied to the AUX terminals.

**F. The PCB fuse keeps blowing:**

When the low-voltage fuse blows, it means the transformer would have just blown if the fuse had not been in the circuit to protect it. The fuse usually blows when there is a high current draw on the transformer, high voltage applied to the low-voltage circuit, or a direct secondary short. When there is a high current draw on the transformer, it is most likely because the transformer has been shorted or the system is trying to draw more va than the transformer is rated for. When the fuse blows because of high voltage, the system has mixed high- and low-voltage signals.

1. Check the transformer and thermostat wiring as shown in Fig. 10. Make sure the transformer is not shorting out by the thermostat wires being miswired.
2. Check the wiring of the sequencers as shown in Fig. 12. Make sure the low-voltage and the high-voltage wiring are connected to the proper sequencers.
3. Check the va draw on the transformer. If the va draw is more than the va rating of the transformer, the fuse will blow. If this is the case, replace the transformer with 1 that has a higher va rating and meets system specifications.

**G. The fan runs continuously:**

1. If the PCB has no low-voltage power, check the blue and black fan leads. These may be switched at the sequencer.
2. If the PCB has low-voltage power, check the fan relay to see if it is opening and closing. It may be stuck in the normally closed position due to debris in the relay.
3. See Service Manager Bulletin (SMB) 92-3.

**H. Transformer failure:**

1. Check the 208-v and 240-v taps connected to T1, and T3. They may be miswired.

**ELECTRIC HEATER FUNCTION AND TROUBLESHOOTING**

This section describes KFA and KFB series electric heaters in exclusion of Smart Heat by examining the functional operation of these heaters.

**I. DESCRIPTION OF ELECTRIC HEATER COMPONENTS**

**A. Limit Switch**

The limit switch is a temperature-sensitive control whose function is to prevent system from overheating in abnormal conditions. The temperature settings often vary from heater to heater due to variations in airflow patterns and element radiant heat conditions. The devices are sized to remain on-line under heat pump conditions (115°F air off coil) and minimum CFM, but trip to prevent outlet air conditions above 200°F or excessive component or duct temperatures.

The device itself consists of a bimetallic disc, which when overheated "snaps through" to open a normally-closed high-voltage, high-current switch. When system temperatures cool sufficiently, the switch will automatically reset to its closed position. Normal failure mode for this switch is open.



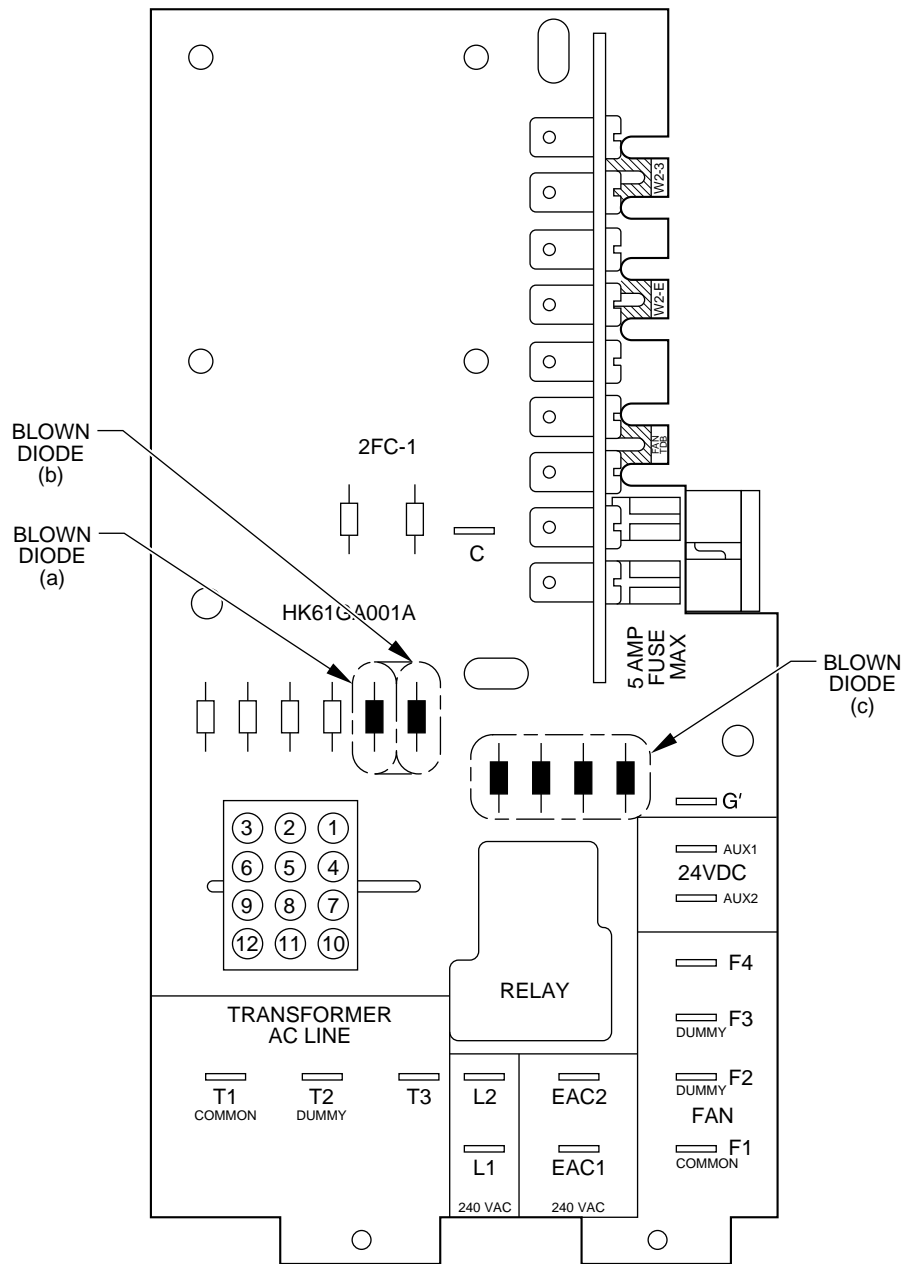

Fig. 13—Control Board Noting Diodes

A97033

If a limit switch has been determined to be defective, NEVER BYPASS THE LIMIT SWITCH. When replacing limit switch, ensure that it is replaced with a limit switch of identical opening temperature and closing differential. Limits switches are typically color coded to identify their range.

### B. Sequencer

The sequencer is essentially a thermally activated time-delay relay normally activated by low-voltage control signals from thermostat. The typical sequencer is a 1- or 2-pole normally-open device which energizes within 10 to 30 sec after application of control signal and de-energizes 60 to 90 sec after control signal is removed.

In simplistic terms, the sequencers which we use are nothing more than normally-open limit switches which sit on top of a small resistive heater. When voltage is applied to this heater, a positive temperature coefficient resistor (PTC), heat is supplied to a bimetallic disc which "snaps through" and closes switch.

The time required for PTC to heat to a sufficient point controls ON timing of device. The time required for disc to cool down when power is removed controls OFF time of device. The PTC can be varied to provide varied timing. Typically a short ON equates to a long OFF.

Because this is a thermally-activated device, ambient conditions affect the ON/OFF cycle. Higher ambient temperature means shorter ON times and longer OFF times.

These sequencers may be "ganged up" to 3 on a common mounting plate to control up to 6 heater elements. In this situation, PTCs are different in each sequencer to provide a staged ON of a minimum of 10 sec between each sequencer — 3 stages of 2 elements since the KFA and KFB series heaters use sequencers in which both switches of the 2-pole sequencer close simultaneously. Older models used sequencers which had a minimum delay of 10 sec between each switch.

Application of these devices is such that the first switch ON not only turns on first heater element, but also ensures that indoor fan

is energized, because first ON is last OFF. This ensures fan remains ON until the last heater de-energizes.

### C. Positive Temperature Coefficient (PTC)

The PTC heater is essentially a resistor. It will operate on either AC or DC voltages. It should be noted that because resistance of PTC increases as it heats, initial current inrush is higher than its steady state condition.

## II. TROUBLESHOOTING KFA AND KFB SERIES ELECTRIC HEATERS

### A. Discolored Wire Insulation at Terminal

Check quick-connect terminal at discoloration. Connection may be loose, creating a high resistance through connection point.

### B. Fuse Failure

1. Check for shorted wire. Replace wire. Never try to fix wire using electrical tape.
2. Check shorted element. If element is shorted, replace heater.

### C. No Heat

1. Check fuse for failure. If fuse has failed, refer to Fuse Failure section.
2. Check for faulty transformer. Check output voltage of transformer secondary side R (red) and C (brown). Make sure output is between 18 and 30 vac. If output voltage is low and input voltage tests normal, replace transformer.
3. Check for miswired heater plug harness.
4. Check limit switch or sequencer failure. These switches should have failed in open position. If output voltage is zero v, replace switch.

### D. Heater Will Not Turn Off

1. Check low-voltage wiring for miswire.
2. Check for shorted elements to ground.
3. Replace sequencer contacts. They may be stuck closed.

### E. Nuisance Trips

1. Check for low airflow due to dirty filters, blocked registers, or undersized duct.
2. Check blower motor and wheel for proper operation. Excessive current draw of motor will cause internal overload to trip.
3. The fan speed may be low.

## FAN COIL DESCRIPTION AND TROUBLESHOOTING FK4B

The FK4B is similar to the discontinued FK4A only in that they both have integrated controls and motor (ICM) and their own special circuit board. The greatest difference between the 2 models is the way each goes about delivering air.

Setting up desired airflow on the FK4B is obtained by the selections made on Easy Select circuit board. The motor delivers requested airflow as defined by signals received from Easy Select Board and its internal programming. The major difference is that the FK4B motor reacts to changes in system static pressures to maintain constant airflow.

Unlike conventional fan coils where static pressure affects airflow, the FK4B is a constant airflow unit. The blower delivers requested airflow up to about 0.7 in. of static pressure. The ICM2 is pre-programmed and contains airflows for all modes of operation. Blower characteristics (airflow, torque, and speed-vs-static pressure) are known from laboratory testing. If any 3 characteristics are known, the fourth is defined.

Requested airflow is known because of Easy Select board configuration and thermostat signals. Torque is known because it is directly related to armature current which is measured by motor control. Speed is measured from its generated back EMF. This information is entered into an expression which calculates torque from speed and airflow numbers. If calculation does not match stored blower characteristics, torque is adjusted every 0.8 sec until agreement is reached. The unit does not directly measure static pressure, but does react to a change in static to maintain constant airflow.

### I. INTEGRATED CONTROLS AND MOTOR (ICM2)

The ICM2 is similar to the ICM1 used in FK4A series units, but cannot be used as a replacement without some modification to FK4A unit. Consult SMB 93-0052 for motor conversion kit. The electronics of motor are built into rear of motor, deriving the name ICM. (See Fig. 14.)

An ICM is first fed high voltage AC power through the 5-pin connector. The AC power is then rectified to DC by a diode module. After rectification, DC signal is electronically communicated and fed in sequential order to 3 stator windings. The frequency of communication pulses determines motor speed. The rotor is permanently magnetized.

An ICM is powered with high voltage at all times. The motor will not run with high voltage alone. Low voltage must be applied to control plug to run motor.

## II. PCB LAYOUT AND DESCRIPTION

**NOTE:** Layout of actual PCB is depicted in Fig. 15 and 16.

The control is a single PCB which interfaces a variable-speed ICM2 with other system components.

Power for system is supplied from a 230-vac, 60-Hz line. Class 2 voltage (24 vac nom.), used for thermostat connections, is derived from a transformer located in close proximity to control. The primary and secondary of transformer are connected to control board. The 24-vac secondary circuit includes a socket, soldered into circuit at SEC2, to receive a 5-amp automotive-type fuse.

Connection to heater panel is made through 12-circuit connector P1. Connections to thermostat are made at screw terminals. Line voltage for ICM2 is made through 7-circuit connector P2. Eighteen quick-connect terminals comprise field select taps for motor.

Fuse Data: 5 amp automotive-type ATC/ATO (tan)  
32v

200 percent current opening time of 5 sec maximum

### A. Electrical Connections

Eighteen 0.187-in quick-connect terminals are used to provide programming selections for operating modes of ICM2. The 5 selection modes are listed below. For additional information, refer to Easy Select Configuration Taps section.

- AUX Heat Range—(Violet Wire)
- AC/HP Size—(Blue Wire)
- Type—(Orange Wire)
- AC/HP CFM Adjust—(Black Wire)
- AC/HP Time Delay—(Grey Wire)

## III. SEQUENCE OF OPERATION

### A. Continuous Fan Mode

The thermostat closes circuit R to G. The G signal is sent directly to ICM2.

### B. Cooling Mode—Single Speed or 2-Speed High

Thermostat closes circuits R to Y/Y2 and R to O (heat pump only) for single speed. A circuit from R to Y1 is also required for 2-speed high. The Y/Y2 signal is sent directly to ICM2.

### C. Cooling Mode—Two-Speed Low

Thermostat closes circuits R to Y1 and R to O (heat pump only). The Y1 signal is sent directly to ICM2.

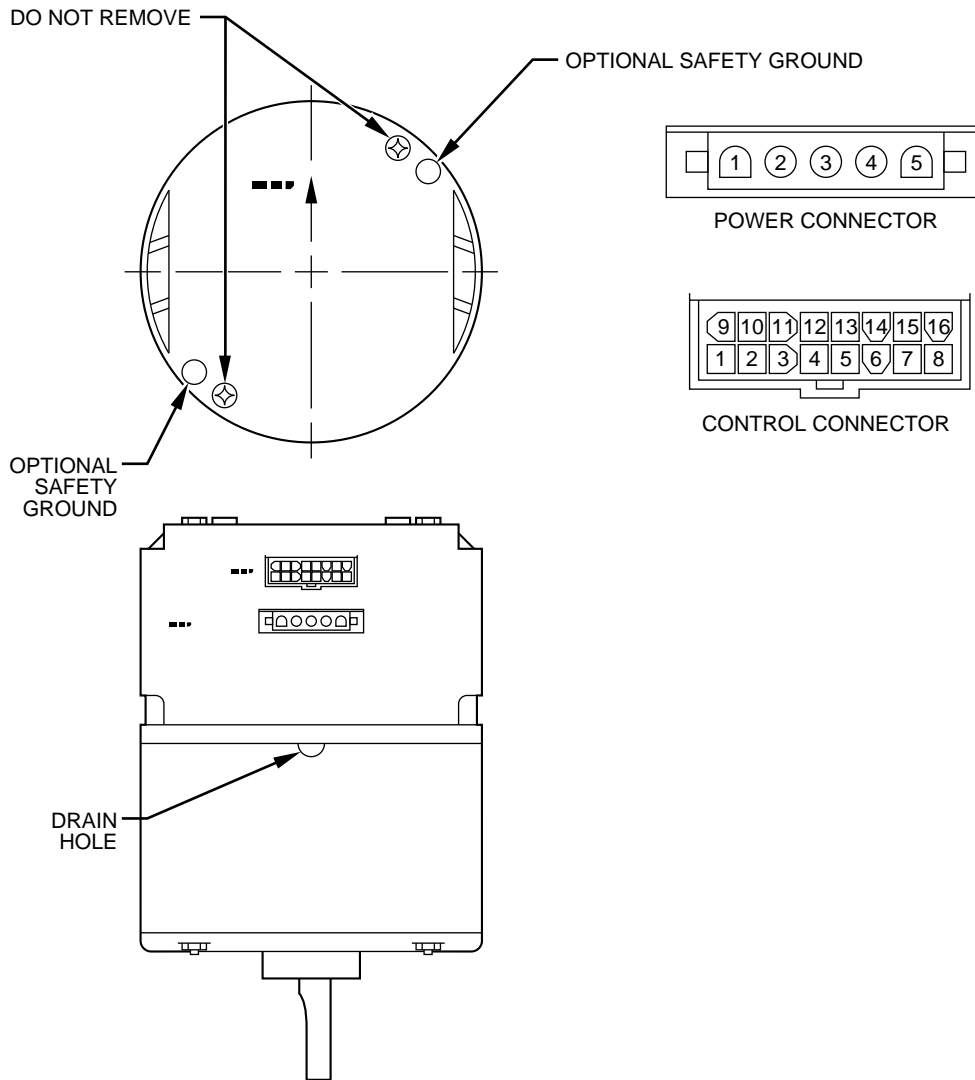

Fig. 14—FK4B ICM2 Motor

A94079

#### D. Electric Heat Heating Mode

Thermostat closes circuit R to W2, W3, or E.

The terminal block positions W2, W3, and E are tied together by jumpers JW1 and JW2. These jumpers are provided for field staging of electric heater banks through use of thermostats. When staging is a requirement, installer cuts jumpers and wires in thermostats as is the common practice with other fan coils. To ensure motor operation if any 1 of the inputs is energized, the 3 electric heater inputs are also interlocked through diodes D1, D2, and D3 to motor W input.

#### E. Heat Pump Heating Mode—Single Speed or 2-Speed High

Thermostat closes circuit R to Y/Y2 for single speed. A circuit from R to Y1 is also required for 2-speed high. The Y/Y2 signal is sent directly to ICM2.

#### F. Heat Pump Heating Mode—Two-Speed Low

Thermostat closes R to Y1. The Y1 signal is sent directly to ICM2.

#### G. Heat Pump Heating With Auxiliary Electric Heat

Thermostat closes circuits R to Y/Y2 and/or R to Y1 with R to W2, W3, or E (and R to O in the case of defrost).

See previously described modes for circuit paths.

In the event that electric heating is called for by thermostat while heat pump is also operating in either heating or defrost mode, electric heating signal will appear at motor connector pin 1 as described previously. If necessary, the motor will modify its airflow output to provide an airflow which is defined as safe for operation of electric heater.

#### H. CFM Select Configuration Taps

The CFM Select taps are used by installer to configure system. The ICM2 is capable of discerning wave shapes on some of its inputs and uses this capability to modify its operation to a pre-programmed table of airflows and can be modified in response to other inputs such as the need for de-humidification.

#### I. ICM2 Control Power

The ICM2 control power is supplied from R circuit through printed-circuit runs to motor control connector pin 6, through motor control harness to motor. The C side of low-voltage control power circuit is connected by printed-circuit runs to motor connector pins 4 and 5, then through motor control harness to motor.

#### J. Low-Voltage Circuit Fusing and Reference

The low-voltage circuit is fused by a board-mounted 5-amp automotive-type fuse placed in series with transformer SEC2 and

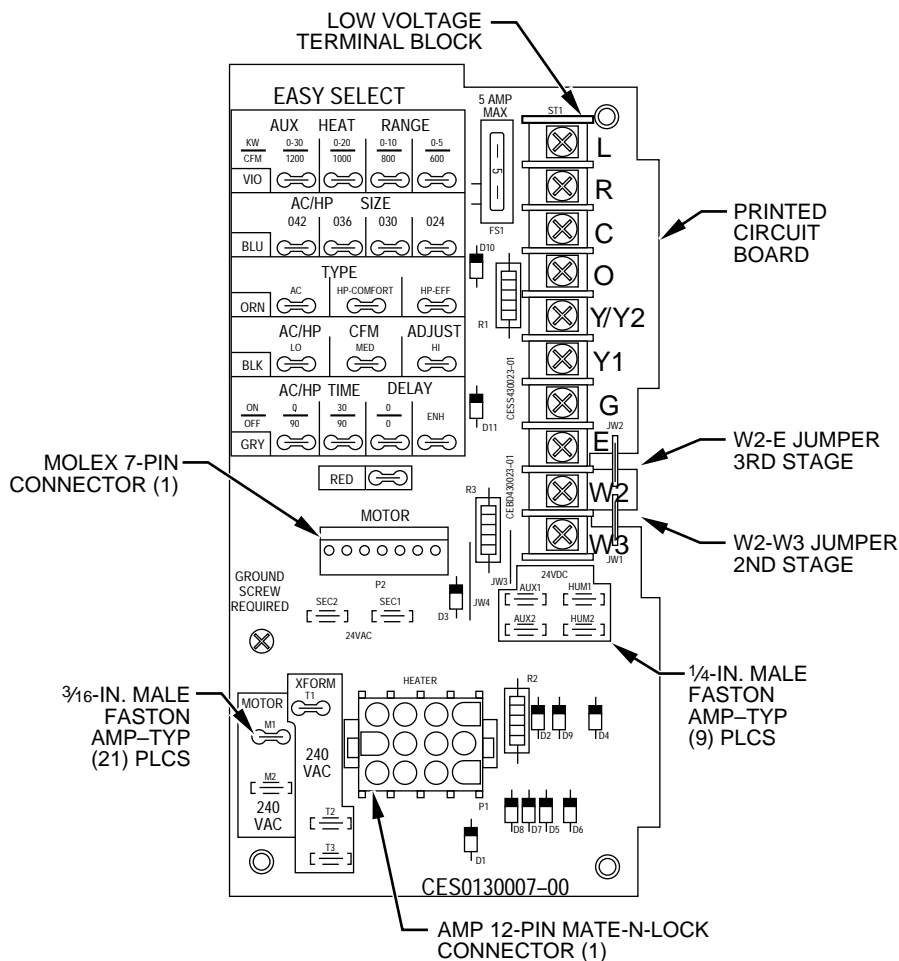

Fig. 15—Easy Select Board

A94076

R circuit. The C circuit of transformer is referenced to chassis ground through a printed-circuit run at SEC1 connected to metal standoff marked GROUND SCREW REQUIRED.

**NOTE:** A ground screw must be in place or erratic motor operation can result.

**K. Transformer, Motor, and Electric Heater Power Connections**

The high-voltage (230-vac) power input to board is provided through electric heater connector pins 7 and 9. The high voltage is then connected through printed-circuit runs to motor power connections M1 and M2 and transformer power connections T1 and T3. Transformer connection T2 is a dummy terminal used for unused primary power lead. The transformer secondary connections are made at SEC1 and SEC2 connectors.

**IV. EASY SELECT CONFIGURATION TAPS**

The Easy Select taps are used by installer to configure system. The ICM2 uses selected taps to modify its operation to a pre-programmed table of airflows. Airflows are based on system size or mode of operation and those airflows are modified in response to other inputs such as the need for de-humidification. (See Fig. 15.)

The FK4B Fan Coil must be configured to operate properly with system components with which it is installed. To successfully configure a basic system (see information printed on circuit board located next to select pins), move the 5 select wires to pins which match components used.

**A. Auxiliary Heat Range**

The installer must select the auxiliary heat airflow approved for application with kw size heater installed. If no heater is installed, skip this step. Each select pin is marked with a range of heaters for

which airflow (also marked) is approved. The heater installed must fall within range selected for safe and continuous operation. It is appropriate to mention that airflow marked is the airflow which will be supplied in emergency heat mode and heating mode on air conditioners when electric heat is primary heating source. To ensure safe heater operation in heat pump heating mode when electric heaters are energized, the ICM2 will run the higher of heat pump efficiency airflow and electric heater airflow. The factory selection is largest heater range approved. (See Fig. 15.)

**B. AC/HP Size**

The factory setting for air conditioner or heat pump size is largest unit meant for application with model of fan coil purchased. The installer needs to select air conditioner or heat pump size to ensure that airflow delivered falls within proper range for size of unit installed in all operational modes. (See Fig. 15.)

**C. System Type**

The type of system must be selected.

1. AC—air conditioner
2. HP-COMFORT—provides same airflow as air conditioner selection (approximately 375 CFM/ton)
3. HP-EFF—provides most efficient airflow for heating and cooling modes (approximately 410 CFM/ton heating and 375 CFM/ton cooling)

The factory setting is AC. (See Fig. 15.)

**D. AC/HP CFM Adjust**

Select low, medium, or high airflow. To provide any of these airflows, AC/HP ADJUST select must be moved to MED position. The factory selection is LO. The adjust selections HI/LO will

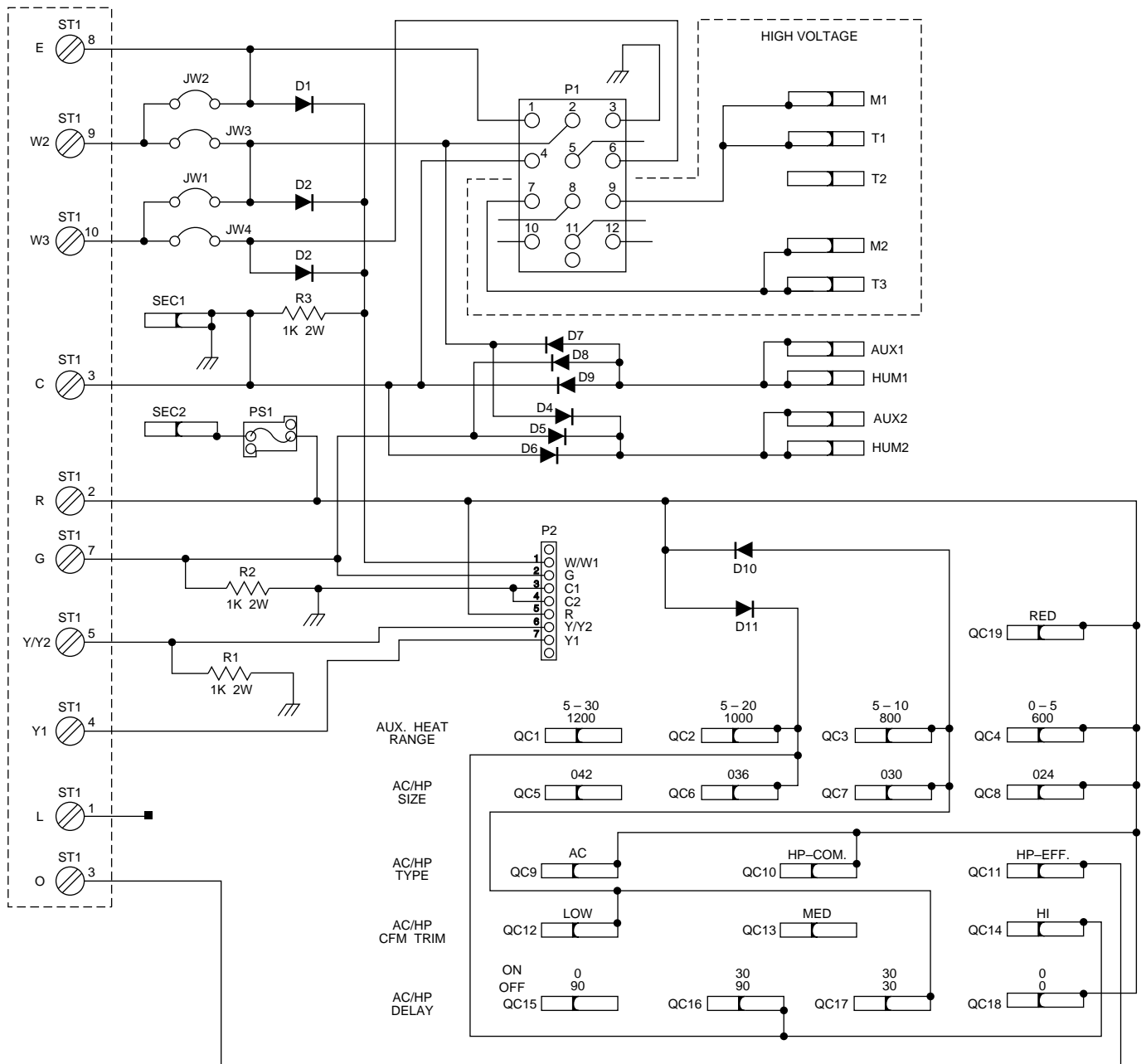

**Fig. 16—Easy Select Board Circuitry**

regulate airflow supplied for all operational modes, except non-heat pump heating modes, +10 percent and -10 percent respectively. The adjust selection options are provided to adjust airflow supplied to meet individual installation needs for such things as noise, comfort, and humidity removal. (See Fig. 15.)

**E. AC/HP Time Delay**

Select desired time delay profile. Four motor operation delay profiles are provided to customize and enhance system operation. (See Fig. 15.) The selection options are:

1. The standard 90 sec off delay (factory setting).
2. No delay option used for servicing unit or when a thermostat is utilized to perform delay functions.
3. A 30 sec on/90 sec off delay profile used when it is desirable to allow system coils time to heat up/cool down prior to airflow. This profile will minimize cold blow in heat pump operation and could enhance system efficiency.
4. ENH, enhanced selection provides a 30 sec on/180 sec off delay at half airflow, adding comfort and efficiency.

A94077

**V. TROUBLESHOOTING PCB**

Use Fig. 16 and 17 and Tables 3, 4, and 5 as guides in troubleshooting PCB unless otherwise noted.

**A. If Fan Will Not Turn On From Thermostat:**

IF THERE IS NO HIGH VOLTAGE TO PCB:

1. Check connection of 12-pin plug from heaters to receptacle on Easy Select board. This supplies power to PCB. Be sure plug is connected properly.
2. Check sequencer number 1 and plug wiring. Yellow wire should be connected to pin number 9 of plug and to limit switch. Black wire should be connected to pin number 7 of plug and to sequencer number 1.
3. Check power leads L1 and L2. If these are not receiving power, system cannot function.

**TABLE 3—MALE/FEMALE QUICK-CONNECT TERMINALS**

SIZE FEMALE	SIZE MALE	DESCRIPTION
0.250 X 0.032	M2	Motor line voltage connection (230 vac 60 Hz)
	T3	Transformer line voltage connection (230 vac 60 Hz)
	T2	Transformer tap storage terminal for 208-vac lead
	SEC1	Secondary connection from transformer (24 vac) This connection is common to chassis ground through eyelet marked GROUND SCREW REQUIRED.
	SEC2	Secondary connection from transformer (24 vac)
	HUM1	Low voltage ground for humidifier option (24 vdc)
	HUM2	Low voltage output for humidifier option (24 vdc)
	AUX1	Low voltage ground for auxiliary option (24 vdc)
0.187 X 0.032	AUX2	Low voltage output for auxiliary option (24 vdc)
	M1	Common connection to blower motor
	T1	Common connection for transformer
	RED	Common to R screw terminal and SEC2

**TABLE 4—CONNECTIONS ON SINGLE BARRIER STRIP MOUNTED, CROSS SLOTTED, CAPTIVE BINDING HEAD**

SCREW TERMINAL	DESCRIPTION
W2	Connection for W2 signal from thermostat
W3	Connection for W3 signal from outdoor thermostat
E	Connection for E signal from thermostat
Y/Y2	Connection for Y signal from thermostat
G	Connection for G signal from thermostat
O	Connection for O signal from thermostat
L	This connection is a field termination for use in connecting L lines of thermostat and outdoor unit together. There is no connection of this terminal with control circuitry.
Y1	Connection for low-speed compressor operation
R	Connection for R signal to thermostat (24 vac)
C	Connection for C terminal to thermostat (24 vac common)

**TABLE 5—CONNECTIONS AND CONNECTOR**

TYPE CONNECTION	TYPE CONNECTOR	PIN NO.	DESCRIPTION
Heater Connection	12-Pin	Pin 1	Common to E screw terminal
		Pin 2	Common to W2 screw terminal
		Pin 3	Common to C screw terminal, SEC1 terminal, and chassis ground
		Pin 4	Common to C screw terminal, SEC1 terminal, and chassis ground
		Pin 5	No connection
		Pin 6	Common to W3 screw terminal
		Pin 7	Common to M2 and T3 quick-connects, 230 vac input
		Pin 8	No connection
		Pin 9	Common to M1 and T1 quick-connects, 230 vac input
		Pin 10	No connection
		Pin 11	No connection
		Pin 12	No connection
ICM2 Motor	7-Pin Header	Pin 1	Diode OR output of E or W3 or W2 thermostat signals
		Pin 2	Thermostat G signal
		Pin 3	Common to C, SEC1, and chassis ground
		Pin 4	Common to C, SEC1, and chassis ground
		Pin 5	Common to R and SEC2 (via 5-amp fuse)
		Pin 6	Thermostat Y/Y2 signal
		Pin 7	Thermostat Y1 signal

**IF PCB HAS HIGH VOLTAGE APPLIED TO IT:**

1. Check low-voltage transformer leads (red and brown). Be sure they are wired to correct locations. (See Fig. 15 and 17.)
2. Check output voltage of transformer secondary side SEC2 and SEC1. Be sure transformer output is around 24 vac. If transformer output is zero vac and transformer is receiving correct input voltage (208v or 240v), then transformer needs to be replaced with recommended transformer. If transformer output is 24 vac, proceed to items 3 and 4.

3. Check low-voltage fuse shown in Fig. 15. If fuse is blown, replace it. The transformer cannot supply power to board with fuse blown or loose. If fuse blows when unit has power applied to it, the system most likely has 1 of the following problems:

THIS COMPARTMENT MUST BE CLOSED EXCEPT FOR SERVICING



**CAUTION:**  
NOT SUITABLE FOR USE ON SYSTEMS  
EXCEEDING 150V TO GROUND

**ATTENTION:**  
NE CONVIENT PAS AUX INSTALLATIONS  
DE PLUS DE 150 V A LA TERRE

30KW 1PH SCHEMATIC DIAGRAM

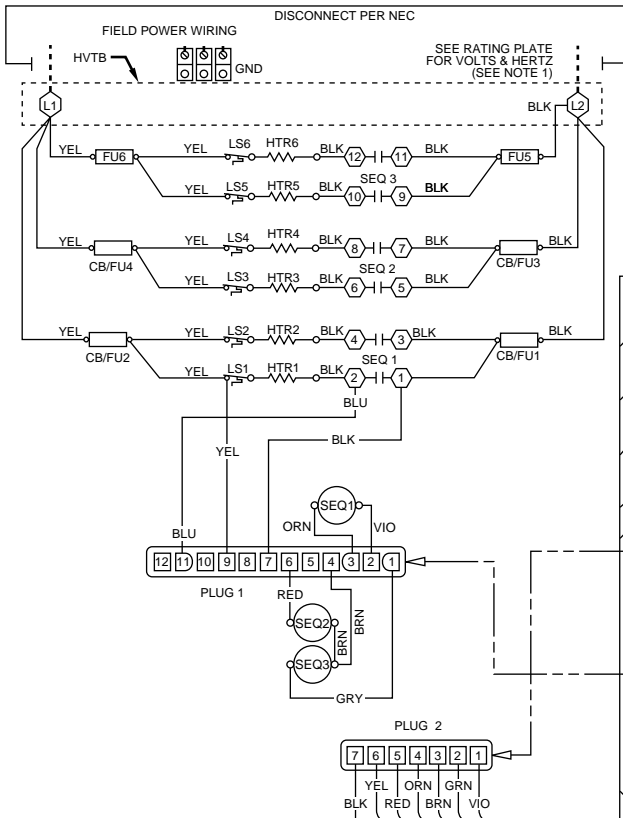

SCHEMATIC DIAGRAM

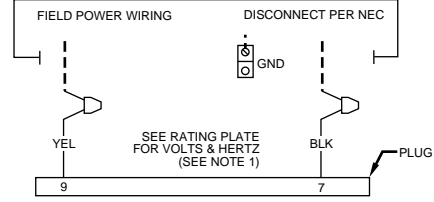

COOLING CONTROL WIRING

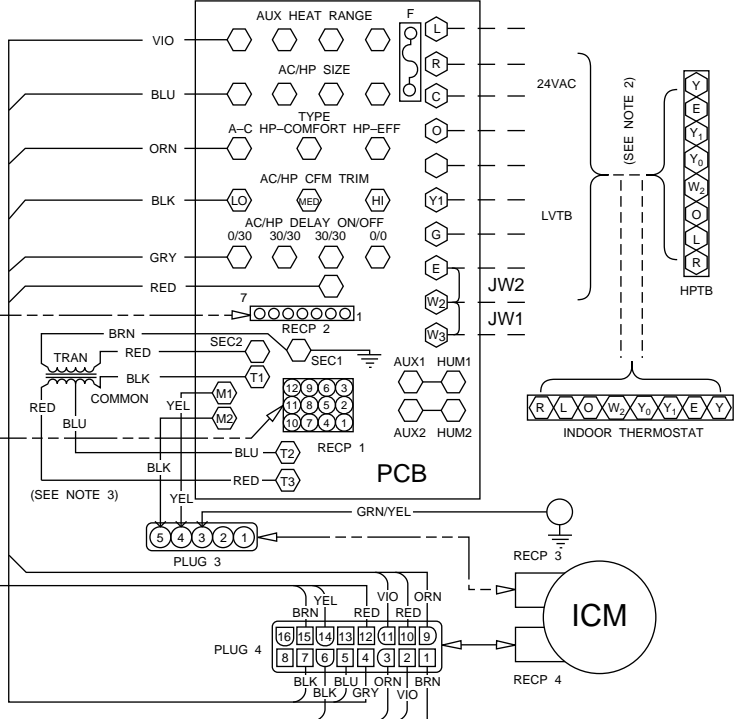

NOTES:

1. Use copper wire only between disconnect switch and unit.
2. Connect (Y) to (Y), (C) to (C), etc. in pattern shown.
3. Transformer primary leads: BLUE 208V, RED 230V.
4. To be wired in accordance with NEC and local codes.
5. If any of the original wire, as supplied, must be replaced, use the same or equivalent type wire.
6. Replace low voltage fuse with no greater than 5 amp fuse.
7. Fuse is wired in series between transformer SEC2 and low voltage "R" circuit.
8. 20KW heater uses one double pole LS on middle top element.
9. 18, 24 and 30KW heaters use double pole limit switches.
10. Largest heaters are shown, smaller heaters will have fewer elements and components.
11. 1 phase heaters are shown wired for single supply circuit. Multiple supply circuits may be wired directly to fuse/C.B.'S.

- LEGEND -

○	MARKED TERMINAL	LS	LIMIT SWITCH
○	UNMARKED TERMINAL	ICM	FAN MOTOR
---	FIELD POWER WIRING	TRAN	TRANSFORMER
⊳	PLUG AND RECEPTACLE	GND	EQUIPMENT GROUND
—	PCB BREAKOFF JUMPER	FU	FUSE
AUX	AUXILIARY	REC	RECEPTACLE
PCB	PRINTED CIRCUIT BOARD	CB	CIRCUIT BREAKER
HPTB	HEAT PUMP TERM BRD	F	LOW VOLTAGE FUSE
LVTB	LOW VOLT TERM BRD		
SEQ	SEQUENCER		
HTR	HEATER		
HVTB	HIGH VOLTAGE TERMINAL BOX		
HUM	HUMIDIFIER		

320486 - 301 REV. C

Fig. 17—FK4B Wiring Diagram

**TABLE 6—MOTOR CONTROL TEST VALUES**

OPERATING MODE		SCREW TERMINALS HAVING 24 VAC				VOLTAGES—7-PIN PLUG P2						
						W Pin 1	G Pin 2	C Pin 3	C Pin 4	R Pin 5	Y/Y2 Pin 6	Y Pin 7
Electric	Heating	R	W2	W3*	E*	24 vdc	0	0	0	24 vac		0
1-Speed A/C	Cooling	R	Y/Y2	G		0	24 vac	0	0	24 vac	24 vac	0
2-Speed A/C, Low Speed	Cooling	R	Y1	G		0	24 vac	0	0	24 vac	0	24 vac
2-Speed A/C, High Speed	Cooling	R	Y/Y2	G		0	24 vac	0	0	24 vac	24 vac	0
1-Speed HP	Cooling	R	Y/Y2	G	O	0	24 vac	0	0	24 vac	24 vac	0
1-Speed HP	Heating	R	Y/Y2	G		0	24 vac	0	0	24 vac	24 vac	0
2-Speed HP, Low Speed	Cooling	R	Y1	G	O	0	24 vac	0	0	24 vac	0	24 vac
2-Speed HP, Low Speed	Heating	R	Y1	G		0	24 vac	0	0	24 vac	0	24 vac
2-Speed HP, High Speed	Cooling	R	Y/Y2	Y1	G	O	0	24 vac	0	24 vac	24 vac	24 vac
2-Speed HP, High Speed	Heating	R	Y/Y2	Y1	G		0	24 vac	0	24 vac	24 vac	24 vac
Continuous Fan		R	G			0	24 vac	0	0	24 vac	0	0

\* Pin 1 @ 24 vdc with or without jumpers when ever any individual heater input or any combination of heater inputs are energized.

- Check control circuit for a short or miswiring problem.
- The maximum load on transformer is 40 va. If load on transformer is excessive, the low-voltage 5-amp fuse will blow to protect transformer. If load exceeds va rating of transformer, a larger va rated transformer needs to be installed. Check sequencers for excessive current draw.
- Check wiring of heaters. If a heater is miswired, fuse may blow. If a heater is miswired, correct miswiring.
- Check T1, T2, and T3 connections on primary side of transformer. If they are not connected properly, low-voltage terminal board cannot supply 24-v signal to energize fan motor. If transformer is receiving correct primary voltage but is not putting out correct secondary voltage, transformer needs to be replaced.

**B. If Electric Heat Stages Will Not Turn On But Fan Will Turn On:**

- Check wiring of sequencers. Pay particular attention to high- and low-voltage wiring of sequencers.
- Check plug wiring to make sure that it is wired correctly.
- Check voltage to sequencer. Sequencer number 1 receives a 24-vac signal. If it is receiving correct voltage, check to see if sequencer is closing. If sequencer is not closing but is receiving correct voltage, replace sequencer. If sequencer is closing, check high-voltage wiring as discussed in items 1 and 2.

**IF THERE ARE BLOWN DIODES:**

If diodes are blown, it is probable electric heater plug is miswired. Correct miswiring.

**NOTE:** Board will need to be replaced if diode is bad.

**IF TRACES ARE OVERHEATED ON BACK OF PCB:**

Usually whenever there is a trace blown on PCB, it means either there has been a high-voltage short or high voltage has been applied to low-voltage circuit. This can be prevented by making sure PCB is wired correctly before PCB has power applied to it.

**C. If PCB Fuse Keeps Blowing:**

When low-voltage fuse blows, it means transformer would have blown if fuse had not been in circuit to protect it. The fuse usually blows when there is a high current drawn on transformer, high voltage applied to low-voltage circuit, or a direct secondary short. When there is a high current drawn on transformer, it is most likely because transformer has been shorted or system is trying to draw more va than transformer rating allows. When fuse blows because of high voltage, the system has mixed high- and low-voltage signals.

- Check transformer and thermostat wiring. (See Fig. 15 and 17.) Be sure transformer is not shorting out because thermostat wires are miswired.
- Check wiring of sequencers. (See Fig. 15 and 17.) Be sure low-voltage and high-voltage wiring are connected to proper sequencers.
- Check va draw on transformer. If va draw is more than va rating of transformer, fuse will blow. If this is the case, replace transformer with one that has a higher va rating and meets system specifications.

**VI. TROUBLESHOOTING ICM2 FAN MOTOR**

**A. If Motor Does Not Run:**

- With power turned off, check all plugs and receptacles on circuit board and at motor for any deformation that may cause a bad connection. Be sure all plugs are placed fully seated.
- Verify that there are approximately 230v at terminals M1 and M2. If not, determine if high voltage is entering board. It enters through black and yellow wires at pins 7 and 9 in 12-pin plug.
- Verify that there is a low-voltage control signal to motor. The motor receives its control signals through the 7-pin motor plug P2. The voltage output of each pin in plug will be different for each mode of operation. Table 6 lists circuit board screw terminals that have 24 vac present (powered by thermostat) and lists voltage that is present at each pin of 7-pin plug for each operating mode. Tests should be taken between points listed and common (C screw terminal). If all values of any 1 of operating modes checks OK and motor fails to run, then motor is defective and should be replaced.

**B. If Motor Does Not Run Smoothly:**

First verify that the cause is not an out-of-balance or damaged blower wheel. If it is not blower wheel, motor is defective and should be replaced.

**C. If Motor Shaft Does Not Rotate Smoothly:**

When manually turning shaft of ICM, the shaft does not rotate smoothly. The shaft has steps during rotation and is referred to as motor cogging. The cogging is caused by permanent magnets passing each pole of motor. However, shaft should not require excessive force to turn. If shaft is VERY difficult to turn, motor control or bearings have failed and motor must be replaced.

**D. If Motor Does Not Stop Running**

- Check for good ground between motor ground lead and transformer common lead.
- If motor continues to run, remove all thermostat wires. If motor stops, replace circuit board.



- 3. If motor continues to run, remove the 7-pin plug. If motor continues to run, replace motor.

## VII. CONDENSED VERSION OF TROUBLESHOOTING FK4B MOTOR AND CONTROLS

This section provides a quick summary of how to troubleshoot the FK4B. If more information is needed, refer to appropriate sections of this service manual.

### + MOTOR

- If motor is hard to turn manually, replace motor.
- If motor does not run, check the components listed below according to their instructions.
  - If motor runs in some operation modes and not in others, check for a good ground connection between motor ground lead and circuit board screw marked "ground screw" and check the room thermostat and wiring harness according to instructions listed below.
  - If motor does not stop running, remove the 7-pin plug from circuit board. If motor continues to run, replace motor. If motor stops running, it is either the circuit board or thermostat causing the problem. Test whether thermostat is at fault by disconnecting it from the board.

### + CIRCUIT BOARD

- Check 5-amp fuse.
- Check for 230v between terminals M1 and M2. If no voltage is present, check power to board. 230-v power enters the board through the black and yellow lead in the 12-pin plug.
- Check for 24v between SEC1 and SEC2. If no voltage is present, check the transformer.
- Check for burn traces or burnt components. If burn spots are present, replace board.

### + ROOM THERMOSTAT

- Remove thermostat wires from the circuit board.
- Jumper screw terminals (1 at a time) R-G, R-Y/Y2, R-Y1, and R-W2. If motor runs in all cases, thermostat is bad. Replace thermostat. If motor does not run, or runs in some cases but not in others, continue by checking the wiring harness.

### + WIRING HARNESS

- Shut off power to unit.
- Remove 5-pin plug from motor.

**CAUTION:** Never remove 5-pin high voltage plug from the motor with the power on.

- Remove 16-pin plug from motor.
- Replace 5-pin plug and turn on power.
- Check for 24v between pin-1 and pin-12 on the 16-pin plug. If no voltage is present, replace wiring harness. (See Fig. 9.)
  - If voltage is present, jumper screw terminal R-Y/Y2 on circuit board and check for 24v between pin-12 and pin-14 on 16-pin plug. (See Fig. 18.) If voltage is present, replace harness.
  - If 24v is present, the motor is bad. Replace motor.

## VIII. ACCESSORIES

### A. Electronic Air Cleaner (EAC)

Familiar 230-vac EAC control/power signal EAC1 and EAC2 is not available, because the ICM2 blower motor used in the FK4B Fan Coil is controlled by low-voltage signals. This signal is replaced by a 24-vdc signal which is provided at circuit board terminals AUX1 and AUX2. (See Fig. 15.)

This signal is present when either G or W is present and is active in all heating and cooling modes. Because 24-vdc relays may not be readily available to installer, a kit exists, KFAIR0101ACR, containing a 24-vdc relay which mounts directly inside EAC cabinet. User-supplied 110 vac is switched by relay to power air cleaner when G or W are present. (See Fig. 19 and 20.)

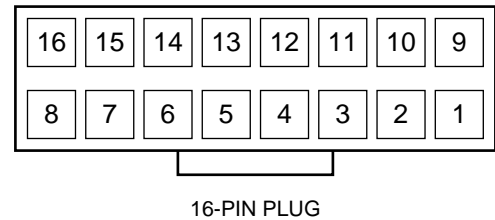

16-PIN PLUG

A94375

Fig. 18—Wiring Harness 16-Pin Plug

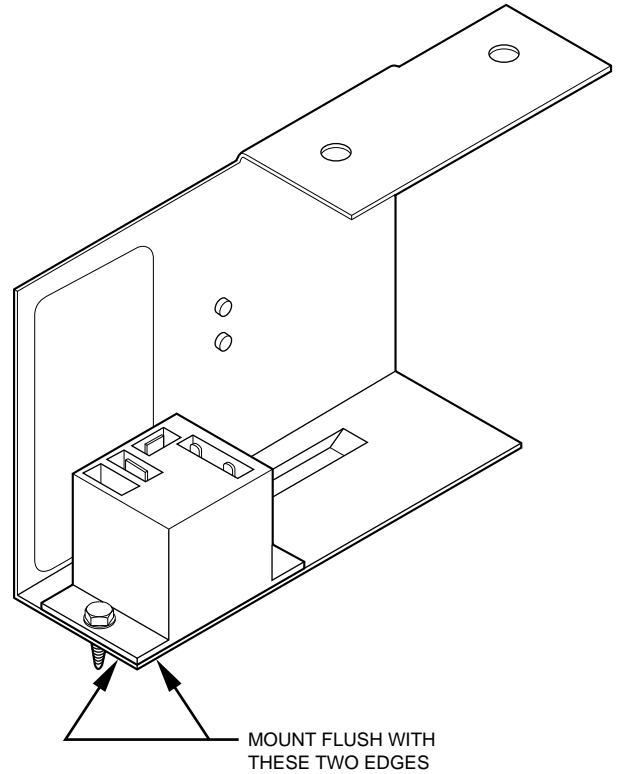

A93216

Fig. 19—Mounting KFAIR0101ACR Relay Kit

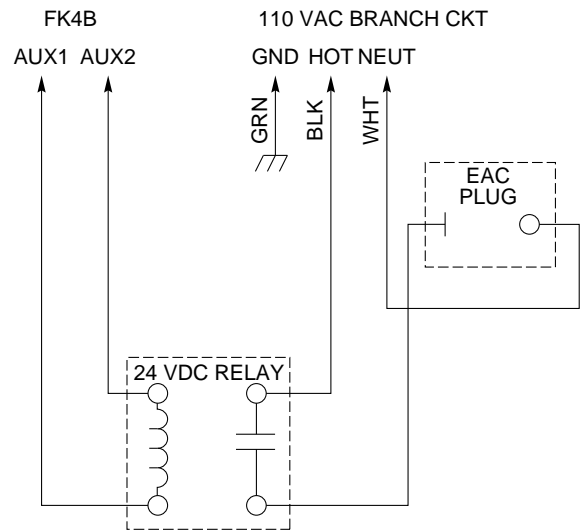

A93217

Fig. 20—KFAIR0101ACR Relay Kit Wiring Schematic

In heat pump applications, the G signal is present in both cooling and heating modes, permitting EAC to be controlled from G signal only. For this application, a user-supplied 24-vac relay can be driven by G terminal eliminating need for relay kit.

## B. FK4B De-Humidify Mode

**NOTE:** Humidistat must open on humidity rise.

Latent capacities for systems using the FK4B Fan Coil are better than average systems. If increased latent capacity is an application requirement, the FK4B can be wired to provide this requirement by adjusting its airflow in response to standard humidistat input. Fig. 21 illustrates the wiring connections to activate de-humidify mode. Carefully consult product airflow data for cooling and dehumidifying mode.

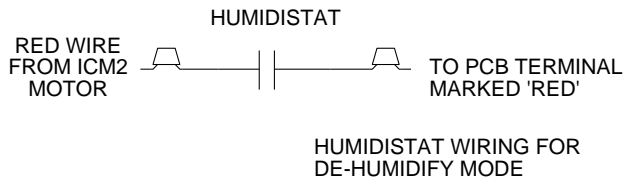

A93215

**Fig. 21—Humidistat Wiring for De-Humidify Mode**

## FK4C

The FK4C is similar to the discontinued FK4B only in that they both have integrated controls and motor (ICM) and their own special circuit board.

Set up of desired airflow on the FK4C is obtained by the selections made on Easy Select circuit board. The motor delivers requested airflow as defined by signals received from Easy Select Board and its internal programming.

Unlike fan coils using induction motors where static pressure affects airflow, the FK4C is a constant airflow unit. The blower delivers requested airflow regardless of static pressure. Consult FK4C Product Data for static pressure limits. The ICM2 is pre-programmed and contains airflow tables for all modes of operation. Blower characteristics (requested airflow, torque, and speed) are known from laboratory testing. If any 2 characteristics are known, the third is defined.

Requested airflow is known from Easy Select board configuration and thermostat signals. Torque is known because it is directly related to stator current which is measured by motor control. Speed is measured by counting back EMF pulses from stator windings. This information is entered into an expression which calculates torque from speed and airflow numbers. If calculation does not match stored blower characteristics, torque is adjusted until agreement is reached. This calculation and adjustment is performed every 0.8 sec while motor is in operation. There is no direct measure of static pressure, but unit does react to a change in static to maintain constant airflow. A change in pressure will result in a change in stator speed and torque. The motor will begin to adjust on the next sampling, calculate new desired speed and torque, and adjust as necessary.

## IX. INTEGRATED CONTROLS AND MOTOR (ICM2)

An ICM is fed high voltage AC power through the 5-pin connector. (See Fig. 22.) The AC power is then rectified to DC by a diode module. After rectification, DC signal is electronically communicated and fed in sequential order to 3 stator windings. The frequency of these commutation pulses determines motor speed. The rotor is permanently magnetized.

An ICM is powered with high voltage at all times. The motor will run with high voltage alone. Low voltage must be applied to control plug to run motor.

## X. PCB LAYOUT AND DESCRIPTION

**NOTE:** Layout of actual PCB is depicted in Fig. 23 and 24.

The PCB interfaces a variable-speed ICM2 with other system components.

Power for system is supplied from a 230-vac, 60-Hz line. Class 2 voltage (24 vac nom.), used for thermostat connections, is derived from transformer located in close proximity to PCB. The primary and secondary of transformer are connected to PCB. The 24-vac secondary circuit includes 5-amp automotive-type fuse in SEC2 circuit.

Connection to heater panel is made through 12-circuit connector P1. Connections to thermostat are made at screw terminals. Twenty-one pin terminals comprise field select taps for motor.

Fuse Data: 5 amp automotive-type ATC/ATO (tan) 32v  
200 percent current opening time of 5 sec maximum

## A. Electrical Connections

Twenty-one 0.110-in pin terminals are used to provide programming selections for operating modes of ICM2. The 6 selection modes are listed below. For additional information, refer to Easy Select Configuration Taps section.

- AUX Heat Range—(Violet Wire)
- AC/HP Size—(Blue Wire)
- Type—(Orange Wire)
- AC/HP CFM Adjust—(Black Wire)
- AC/HP Time Delay—(Grey Wire)
- Continuous Fan—(Yellow Wire)

## XI. SEQUENCE OF OPERATION

### A. Continuous Fan Mode

The thermostat closes circuit R to G. The G signal is sent directly to ICM2.

### B. Cooling Mode—Single Speed or 2-Speed High

Thermostat closes circuits R to Y/Y2 and R to O (heat pump only) for single speed. A circuit from R to Y1 is also required for 2-speed high.

### C. Cooling Mode—Two-Speed Low

Thermostat closes circuits R to Y1 and R to O (heat pump only). The Y1 & O signals are sent to ICM2.

### D. Electric Heat Heating Mode

Thermostat closes circuit R to W1 & W2.

The terminal block positions W1 and W2 are tied together by jumper. J2 is provided for field staging of electric heater banks through use of thermostats. When staging is a requirement, remove J2 jumper and wire in thermostats as is the common practice with other fan coils. To ensure motor operation if any 1 of the inputs is energized, motor will sense input W1 or W2 and run.

### E. Heat Pump Heating Mode—Single Speed or 2-Speed High

Thermostat closes circuit R to Y/Y2 for single speed. A circuit from R to Y1 is also required for 2-speed high. The Y/Y2 & Y1 signal is sent to ICM2.

### F. Heat Pump Heating Mode—Two-Speed Low

Thermostat closes R to Y1. The Y1 signal is sent to ICM2.

### G. Heat Pump Heating With Auxiliary Electric Heat

Thermostat closes circuits R to Y/Y2 and/or R to Y1 with R to W1 or W2 (and R to O in the case of defrost).

The terminal block positions W1 and W2 are tied together by jumper. J2 is provided for field staging of electric heater banks through use of thermostats. When staging is a requirement, remove J2 jumper and wire in thermostats as is the common practice with other fan coils. To ensure motor operation if any 1 of the inputs is energized, motor will sense input W1 or W2 and run.

In the event that electric heating is called for by thermostat while heat pump is also operating in either heating or defrost mode, electric heating signal will appear at motor connector pins 6 and 7 (W1) and/or pins 4 and 5 (W2) as described previously. If necessary, the motor will modify its airflow output to provide an airflow which is defined as safe for operation of electric heater.

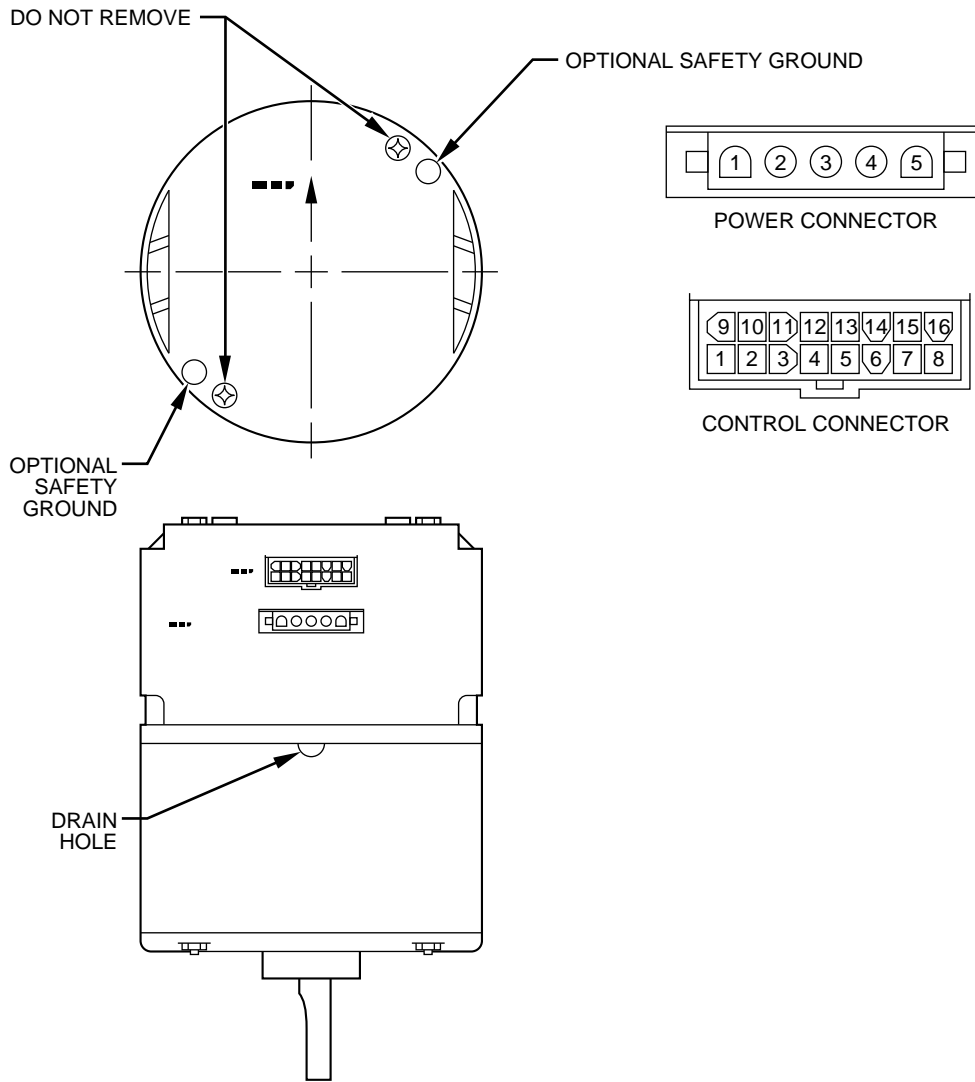

Fig. 22—FK4C ICM2 Motor

A94079

#### H. CFM Select Configuration Taps

The CFM Select taps are used by installer to configure system. The ICM2 is capable of discerning half cycle sine wave on some of its inputs and uses this capability to modify its operation to a pre-programmed table of airflows and can be modified in response to other inputs such as the need for de-humidification.

#### I. ICM2 Control Power

The ICM2 control power is supplied from R circuit through printed-circuit runs to motor control connector pin 8, through motor control harness to motor. The C side of low-voltage control power circuit is connected by printed-circuit runs to motor connector pins 9, 10 and 11 then through motor control harness to motor.

#### J. Low-Voltage Circuit Fusing and Reference

The low-voltage circuit is fused by a board-mounted 5-amp automotive-type fuse placed in series with transformer SEC2 and R circuit. The C circuit of transformer is referenced to chassis ground through a printed-circuit run at SEC1 connected to metal standoff marked.

**NOTE:** The PCB must be mounted with 2 screws and motor ground lead secured to blower housing or erratic motor operation can result.

#### K. Transformer, Motor, and Electric Heater Power Connections

Transformer high voltage supplied from electric heater package or high voltage leads through 12-pin heater connector plug/recp 2. The ICM2 power connections are made at the transformer primary terminals. [The transformer secondary connections are made at SEC1 and SEC2 connectors.

#### XII. EASY SELECT CONFIGURATION TAPS

The Easy Select taps are used by installer to configure system. The ICM2 uses selected taps to modify its operation to a pre-programmed table of airflows. Airflows are based on system size or mode of operation and those airflows are modified in response to other inputs such as the need for de-humidification. (See Fig. 23.)

The FK4C Fan Coil must be configured to operate properly with system components with which it is installed. To successfully configure a basic system (see information printed on circuit board located next to select pins), move the 6 select wires to pins which match components used, along with homeowner preferences.

#### A. Auxiliary Heat Range

The installer must select the auxiliary heat airflow approved for application with kw size heater installed. If no heater is installed, skip this step. Each select pin is marked with a range of heaters for

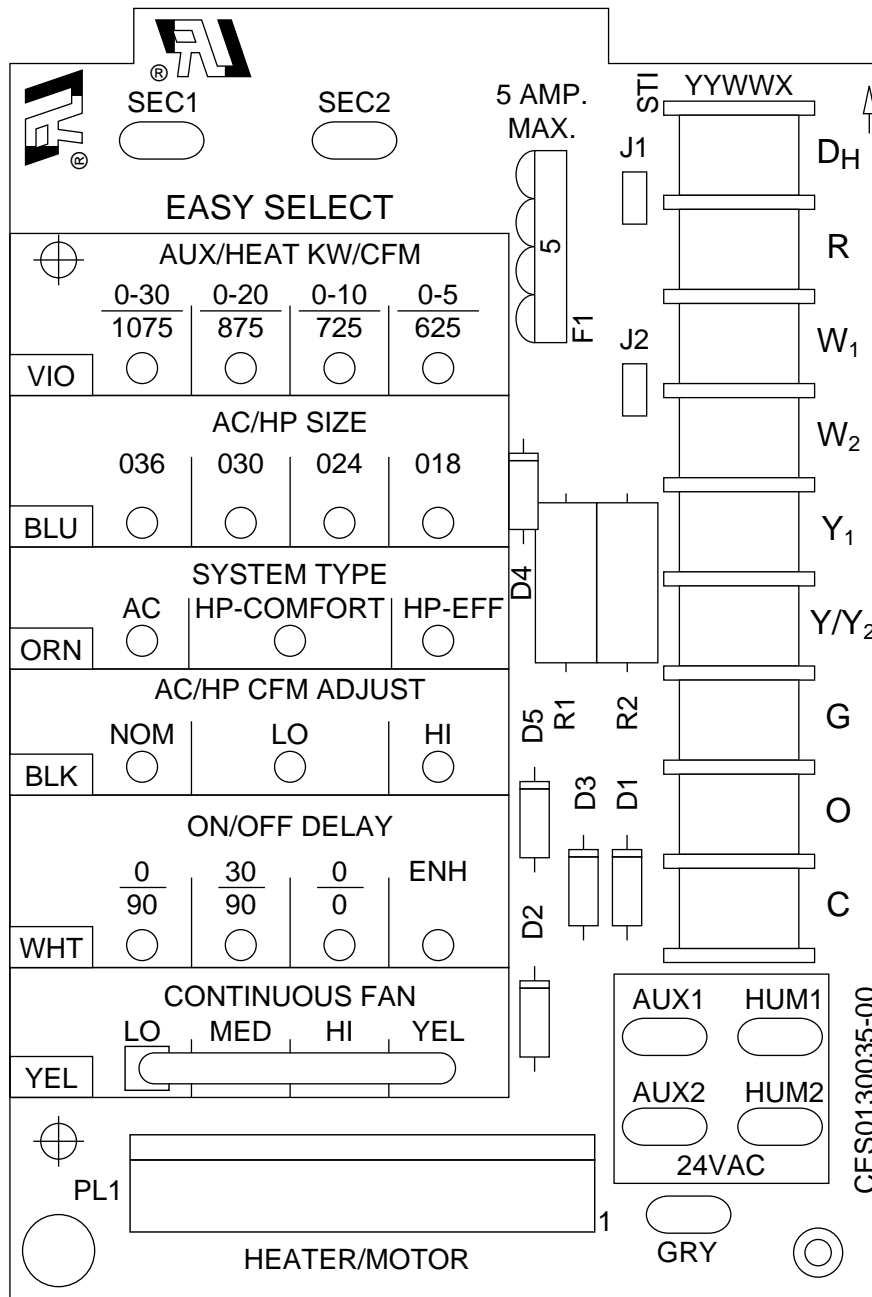

Fig. 23—Easy Select Board

A96430

which airflow (also marked) is approved. The heater installed must fall within range selected for safe and continuous operation. It is appropriate to mention that airflow marked is the airflow which will be supplied in emergency heat mode and heating mode on air conditioners when electric heat is primary heating source. To ensure safe heater operation in heat pump heating mode when electric heaters are energized, the ICM2 will run the higher of heat pump airflow and electric heater airflow. The factory selection is largest heater range approved. (See Fig. 23.)

#### B. AC/HP Size

The factory setting for air conditioner or heat pump size is largest unit meant for application with model of fan coil purchased. The installer needs to select air conditioner or heat pump size to ensure that airflow delivered falls within proper range for size of unit installed in all operational modes. (See Fig. 23.)

#### C. System Type

The type of system must be selected.

1. AC—air conditioner

2. HP-COMFORT—provides lower airflow than air conditioner selection (approximately 315 CFM/ton) in heating mode. In cooling mode supplies 350 CFM/ton.
3. HP-EFF—provides same airflow for heating and cooling modes (approximately 350 CFM/ton).

The factory setting is AC. (See Fig. 23.)

#### D. AC/HP CFM Adjust

Select low, nominal, or high airflow. To provide any of these airflows, AC/HP ADJUST select must be moved to NOM position. The factory selection is NOM. The adjust selections HI/LO will regulate airflow supplied for all operational modes, except non-heat pump heating modes, +15 percent and -10 percent respectively. The adjust selection options are provided to adjust airflow supplied to meet individual installation needs for such things as noise, comfort, and humidity removal. (See Fig. 23.)

## SYSTEM DIAGRAM

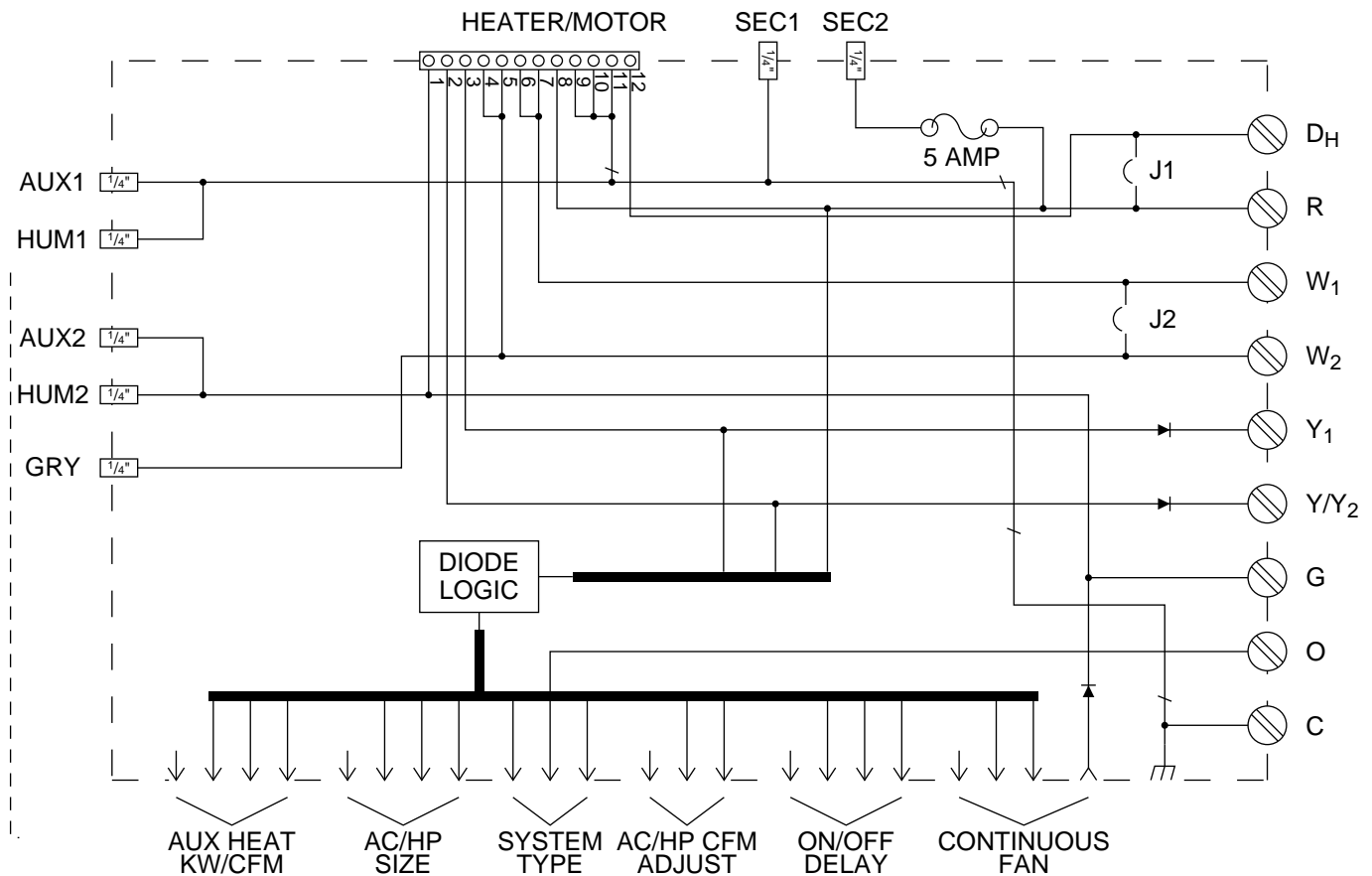

**Fig. 24—Easy Select Board Schematic**

A96431

**TABLE 7—CONNECTIONS ON SINGLE BARRIER STRIP MOUNTED, CROSS SLOTTED, CAPTIVE BINDING HEAD**

SCREW TERMINAL	DESCRIPTION
<b>W2</b>	Connection for W2 signal from thermostat
<b>W1</b>	Connection for signal from thermostat W1
<b>Y/Y2</b>	Connection for Y signal from thermostat or high speed compressor operation
<b>G</b>	Connection for G signal from thermostat
<b>O</b>	Connection for O signal from thermostat
<b>L</b>	This connection is a field termination for use in connecting L lines of thermostat and outdoor unit together. There is no connection of this terminal with control circuitry.
<b>Y1</b>	Connection for low-speed compressor operation
<b>R</b>	Connection for R signal to thermostat (24 vac)
<b>C</b>	Connection for C terminal to thermostat (24 vac common)

### E. AC/HP Time Delay

Select desired time delay profile. Four motor operation delay profiles are provided to customize and enhance system operation. (See Fig. 23.) The selection options are:

1. The standard 90 sec off delay (factory setting 0/90).
2. No delay option used for servicing unit or when a thermostat is utilized to perform delay functions (0/0).
3. A 30 sec on/90 sec off delay profile used when it is desirable to allow system coils time to heat up/cool down prior to airflow. This profile will minimize cold blow in heat pump operation and could enhance system efficiency (30/90).
4. ENH, enhanced selection provides a 30 sec on/180 sec off delay at half airflow, adding comfort and efficiency.

### F. Continous Fan

Select desired Continuous fan profile LO, MED, or HI. Airflow are provided to customize and enhance the continous fan functions. (See Fig. 23.) The possible selections are:

1. LO—provides 50% of Y/Y2 Cool airflow.
2. MED—provides 65% of Cool airflow (71% on FK4CNB006 model).
3. HI—provides 100% of Cool airflow.

The factory setting is LO.

**NOTE:** If applied to two speed unit, do not select continuous fan as high since LO speed cooling will also run at HIGH airflow and insufficient dehumidification may result.

### XIII. TROUBLESHOOTING PCB

Use Fig. 24 and 25 and Tables 7 and 8 as guides in troubleshooting PCB unless otherwise noted.

**TABLE 8—CONNECTIONS AND CONNECTOR**

TYPE CONNECTION	TYPE CONNECTOR	PIN NO.	DESCRIPTION
Heater Connection	12-Pin	Pin 1	Common to screw terminal G
		Pin 2	Common to screw terminal Y/Y2 through diode D3
		Pin 3	Common to Y1 through diode D2
		Pin 4	Common to W2 screw terminal
		Pin 5	Common to W2 screw terminal
		Pin 6	Common to screw terminal W1 screw terminal
		Pin 7	Common to W1 screw terminal
		Pin 8	R 24VAC
		Pin 9	Common to transformer C
		Pin 10	Common to transformer C
		Pin 11	Common to transformer C
		Pin 12	Common to DH screw terminal

**A. If Fan Will Not Turn On From Thermostat:**

IF THERE IS NO HIGH VOLTAGE TO MOTOR:

1. Check connection of 12-pin plug from heaters to receptacle. This supplies power to transformer and motor. Be sure plug is connected properly.
2. Check power leads L1 and L2. If these are not receiving power, system cannot function.

IF MOTOR HAS HIGH VOLTAGE APPLIED TO IT:

1. Check low-voltage transformer leads (red and brown). Be sure they are wired to correct locations. (See Fig. 23 and 25.)
2. Check low-voltage fuse shown in Fig. 23. If fuse is blown, replace it. The transformer cannot supply power to board with fuse blown or loose. If fuse blows when unit has power applied to it, the system most likely has 1 of the following problems:
  - a. Check control circuit for a short or miswiring problem.
  - b. The maximum load on transformer is 40 va. If load on transformer is excessive, the low-voltage 5-amp fuse will blow to protect transformer. If load exceeds va rating of transformer, a larger va rated transformer needs to be installed.
  - c. Check sequencers for excessive current draw.
  - d. Check wiring of heaters. If a heater is miswired, fuse may blow. If a heater is miswired, correct miswiring.
3. Check yellow and black wire connections on primary side of transformer. If they are not connected properly, low-voltage transformer cannot supply 24-v signal to energize fan motor. If transformer is receiving correct primary voltage but is not putting out correct secondary voltage, transformer needs to be replaced.

**B. If Electric Heat Stages Will Not Turn On But Fan Will Turn On:**

1. Check wiring of sequencers. Pay particular attention to high- and low-voltage wiring of sequencers.
2. Check plug wiring to make sure that it is wired correctly.
3. Check voltage to sequencer. Sequencer number 1 receives a 24-vac signal. If it is receiving correct voltage, check to see if sequencer is closing. If sequencer is not closing but is receiving correct voltage, replace sequencer. If sequencer is closing, check high-voltage wiring as discussed in items 1 and 2.

IF TRACES ARE OVERHEATED ON BACK OF PCB:

Usually whenever there is a trace blown on PCB, it means either there has been a high-voltage short or high voltage has been applied to low-voltage circuit. This can be prevented by making sure PCB is wired correctly before fan coil has power applied to it.

**C. If PCB Fuse Keeps Blowing:**

When low-voltage fuse blows, it means transformer would have blown if fuse had not been in circuit to protect it. The fuse usually blows when there is a high current drawn on transformer, high voltage applied to low-voltage circuit, or a direct secondary short. When there is a high current drawn on transformer, it is most likely because transformer has been shorted or system is trying to draw more va than transformer rating allows. When fuse blows because of high voltage, the system has mixed high- and low-voltage signals.

1. Check transformer and thermostat wiring. (See Fig. 23 and 25.) Be sure transformer is not shorting out because thermostat wires are miswired.
2. Check wiring of sequencers. (See Fig. 23 and 25.) Be sure low-voltage and high-voltage wiring are connected to proper sequencers.
3. Check va draw on transformer. If va draw is more than va rating of transformer, fuse will blow. If this is the case, replace transformer with one that has a higher va rating.

**XIV. TROUBLESHOOTING ICM2 FAN MOTOR**

**A. If Motor Does Not Run:**

1. With power turned off, check all plugs and receptacles on circuit board and at motor for any deformation that may cause a bad connection. Be sure all plugs are placed fully seated.
2. Verify that there is approximately 230v.
3. Verify that there is a low-voltage control signal to motor. The motor receives its control signals through the 12-pin motor plug PL1. The voltage output of each pin in plug will be different for each mode of operation. Table 6 lists circuit board screw terminals that have 24 vac present (powered by thermostat) and lists voltage that is present at each pin of 12-pin plug for each operating mode. Tests should be taken between points listed and common (C screw terminal). If all values of any 1 of operating modes checks OK and motor fails to run, then motor is defective and should be replaced.

**B. If Motor Does Not Run Smoothly:**

First verify that the cause is not an out-of-balance or damaged blower wheel. If it is not blower wheel, motor is defective and should be replaced.

**C. If Motor Shaft Does Not Rotate Smoothly:**

When manually turning shaft of ICM, the shaft does not rotate smoothly. The shaft has steps during rotation and is referred to as motor cogging. The cogging is caused by permanent magnets passing each pole of motor. However, shaft should not require excessive force to turn. If shaft is VERY difficult to turn, motor control or bearings have failed and motor must be replaced.

THIS COMPARTMENT MUST BE CLOSED EXCEPT FOR SERVICING



**CAUTION:**  
NOT SUITABLE FOR USE ON SYSTEMS EXCEEDING 150V TO GROUND

**ATTENTION:**  
NE CONVIENT PAS AUX INSTALLATIONS DE PLUS DE 150 V A LA TERRE

30KW 1PH SCHEMATIC DIAGRAM

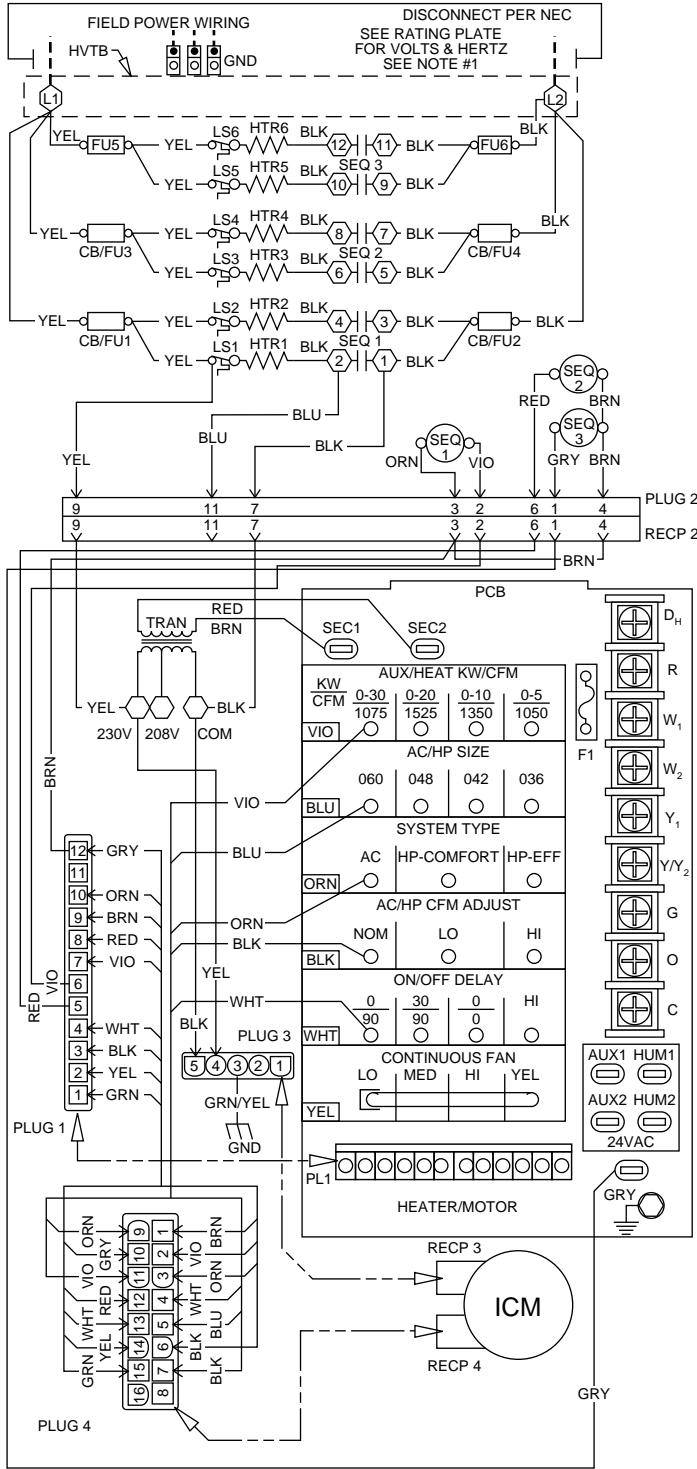

- LEGEND -

- |      |                         |      |                       |
|------|-------------------------|------|-----------------------|
| COM  | COMMON                  | LS   | LIMIT SWITCH          |
| F1   | LOW VOLTAGE FUSE        | ○    | MARKED TERMINAL       |
| ICM  | FAN MOTOR               | →    | PLUG AND RECEPTACLE   |
| ---  | FIELD POWER WIRING      | PCB  | PRINTED CIRCUIT BOARD |
| FU   | LINE FUSE               | SEQ  | SEQUENCER             |
| GND  | EQUIPMENT GROUND        | TRAN | TRANSFORMER           |
| HVTB | HIGH VOLTAGE TERM BLOCK | RECP | RECEPTACLE            |
| HTR  | HEATER                  | CB   | CIRCUIT BREAKER       |

FIELD POWER WIRING

COOLING CONTROL ONLY

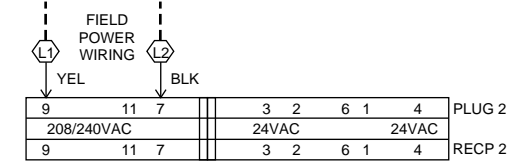

COMPONENT ARRANGEMENT

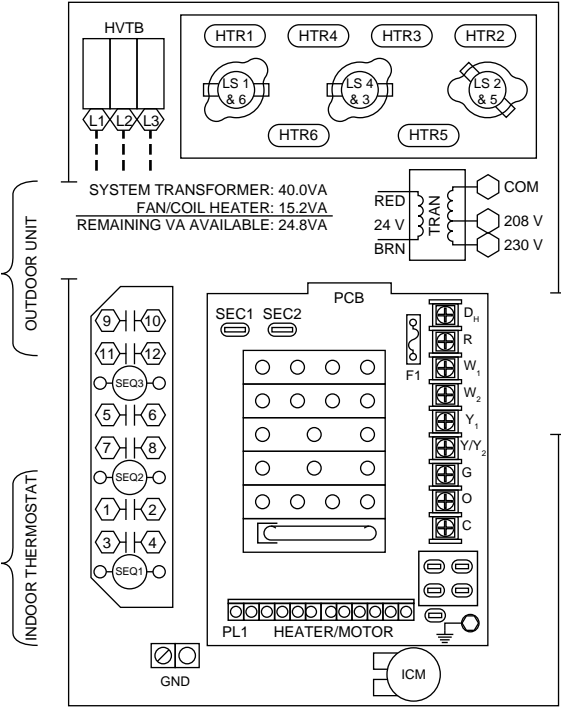

SYSTEM TRANSFORMER: 40.0VA  
FAN/COIL HEATER: 15.2VA  
REMAINING VA AVAILABLE: 24.8VA

NOTES:

1. USE COPPER WIRE (75°C MIN) ONLY BETWEEN DISCONNECT SWITCH AND UNIT.
2. TO BE WIRED IN ACCORDANCE WITH NEC AND LOCAL CODES.
3. TRANSFORMER PRIMARY LEADS: BLUE 208V, RED 230V.
4. IF ANY OF THE ORIGINAL WIRE, AS SUPPLIED, MUST BE REPLACED, USE THE SAME OR EQUIVALENT TYPE WIRE.
5. REPLACE LOW VOLTAGE FUSE WITH NO GREATER THAN 5 AMP FUSE.
6. 20KW HEATER USES ONE DOUBLE POLE LS ON MIDDLE TOP ELEMENT.
7. 18, 24 AND 30KW HEATERS USE DOUBLE POLE LIMIT SWITCHES.
8. LARGEST HEATERS ARE SHOWN, SMALLER HEATERS WILL HAVE FEWER ELEMENTS AND COMPONENTS.
9. 1 PHASE HEATERS ARE SHOWN WIRED FOR SINGLE SUPPLY CIRCUIT.
10. USE 60 AMP CLASS K FUSES ONLY, FOR REPLACEMENT.
11. CONNECT R TO R, G TO G, ETC., SEE OUTDOOR INSTRUCTIONS FOR DETAILS.

322857-101 REV. A

Fig. 25—FK4C Wiring Diagram

**TABLE 9—MOTOR CONTROL TEST VALUES**

OPERATING MODE		SCREW TERMINALS HAVING 24 VAC				VOLTAGES—12-PIN PLUG PL1						
						W1 Pin 7	G Pin 1	C Pin 9	C Pin 10	R Pin 8	Y/Y2 Pin 2	Y1 Pin 3
Electric	Heating	R	W1	W2		24 vac	0	0	0	24 vac		0
1-Speed A/C	Cooling	R	Y/Y2	G		0	24 vac	0	0	24 vac	24 vac	0
2-Speed A/C, Low Speed	Cooling	R	Y1	G		0	24 vac	0	0	24 vac	0	24 vac
2-Speed A/C, High Speed	Cooling	R	Y/Y2	G	Y1	0	24 vac	0	0	24 vac	24 vac	24 vac
1-Speed HP	Cooling	R	Y/Y2	G	O	0	24 vac	0	0	24 vac	24 vac	0
1-Speed HP	Heating	R	Y/Y2	G		0	24 vac	0	0	24 vac	24 vac	0
2-Speed HP, Low Speed	Cooling	R	Y1	G	O	0	24 vac	0	0	24 vac	0	24 vac
2-Speed HP, Low Speed	Heating	R	Y1	G		0	24 vac	0	0	24 vac	0	24 vac
2-Speed HP, High Speed	Cooling	R	Y/Y2	Y1	G	O	0	24 vac	0	24 vac	24 vac	24 vac
2-Speed HP, High Speed	Heating	R	Y/Y2	Y1	G		0	24 vac	0	24 vac	24 vac	24 vac
Continuous Fan		R	G			0	24 vac	0	0	24 vac	0	0

**D. If Motor Does Not Stop Running**

- 1. Check for good ground between motor ground lead and transformer common lead.
- 2. If motor continues to run, remove all thermostat wires. If motor stops, check thermostat wiring to thermostat or outdoor unit for shorts or miswire.

- If 24v is not present, the harness is bad. Replace harness.

- G — Pin 15
- Y1 — Pin 6
- W1 — Pin 2
- W1 — Pin 13

**XV. CONDENSED VERSION OF TROUBLESHOOTING FK4C MOTOR AND CONTROLS**

This section provides a quick summary of how to troubleshoot the FK4C. If more information is needed, refer to appropriate sections of this service manual.

**+ MOTOR**

- If motor is hard to turn manually, replace motor.
- If motor does not run, check the components listed below according to their instructions.
- If motor runs in some operation modes and not in others, check for a good ground connection between motor ground lead and circuit board screw marked "ground screw" and check the room thermostat and wiring harness according to instructions listed below.

**+ CIRCUIT BOARD**

- Check 5-amp fuse.
- Check for 24v between SEC1 and SEC2. If no voltage is present, check the transformer.
- Check for burn traces or burnt components. If burn spots are present, replace board.

**+ ROOM THERMOSTAT**

- Remove thermostat wires from the circuit board.
- Jumper screw terminals (1 at a time) R-G, R-Y/Y2, R-Y1, and R-W1. If motor runs in all cases, thermostat is bad. Replace thermostat. If motor does not run, or runs in some cases but not in others, continue by checking the wiring harness.

**+ WIRING HARNESS**

- Shut off power to unit.
- Remove 5-pin plug from motor.

⚠	<b>CAUTION:</b> Never remove 5-pin high voltage plug from the motor with the power on.
---	--

- Remove 16-pin plug from motor.
- Replace 5-pin plug and turn on power.
- Check for 24v between pin-1 and pin-12 on the 16-pin plug. If no voltage is present, replace wiring harness. (See Fig. 26.)
- If voltage is present, jumper screw terminal R-Y/Y2 on circuit board and check for 24v between pin-1 and pin-14 on 16-pin plug. (See Fig. 26.) If voltage is present, check harness connections G, Y1, W1, W2.

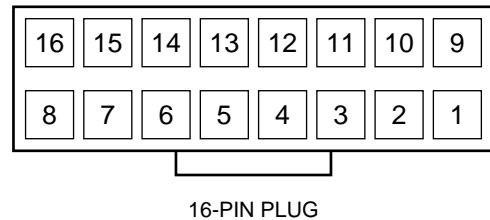

16-PIN PLUG

A94375

**Fig. 26—Wiring Harness 16-Pin Plug**

**XVI. ACCESSORIES**

**A. Electronic Air Cleaner (EAC)**

230-vac EAC control/power signal EAC1 and EAC2 is not available, because the ICM2 blower motor used in the FK4C Fan Coil is controlled by low-voltage signals. This signal is replaced by a 24-vac signal which is provided at circuit board terminals AUX1 and AUX2. (See Fig 23.) This signal is present when either G or W is present and is active in all heating and cooling modes. User-supplied 110 vac is switched by relay to power air cleaner when G or W are present. (See Fig. 27.)

**B. FK4C De-Humidify Mode**

**NOTE:** Humidistat must open on humidity rise.

Latent capacities for systems using the FK4C fan coil are better than average systems. If increased latent capacity is an application requirement, the field wiring terminal block provides connection terminals for use of a standard humidistat. The FK4C fan coil will detect the humidistat contacts opening on increasing humidity and reduce its airflow to approximately 80% of nominal cooling mode airflow. This reduction will increase the system latent capacity until the humidity falls to a level which causes the humidistat to close its contacts. When the contacts close, airflow will return to 100% of the selected cooling airflow. To activate this mode, remove jumper J1 and wire in a standard humidistat. (See Fig. 28.) Carefully consult product airflow data for cooling and dehumidification modes.

**THERMOSTATIC EXPANSION VALVES (TXV)**

The FC4B and FK4C Fan Coils are factory equipped with a hard shutoff (HSO) TXV.

The hard shutoff TXV has no bleed port and allows no bleed-through after system is shutdown. No pressure equalization occurs. A start capacitor and relay must be installed on single-phase reciprocating compressors to boost torque to compressor motor so it may overcome the unequalized system pressures.



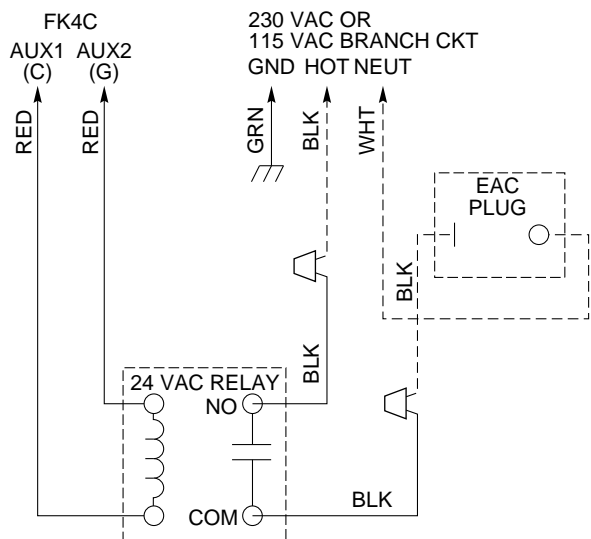

A95318

**Fig. 27—KFAIR0201ACR Relay Kit Wiring Schematic**

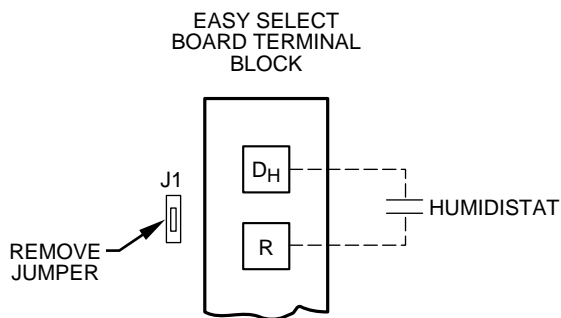

A95316

**Fig. 28—Humidistat Wiring for De-Humidify Mode**

The standard TXV is a bi-flow metering device that is used in condensing and heat pump systems to adjust to changing load conditions by maintaining a preset superheat temperature at outlet of evaporator coil. The volume of refrigerant metered through valve seat is dependent upon the following:

1. Superheat temperature sensed by sensing bulb on suction tube at outlet of evaporator coil. As long as this bulb contains some liquid refrigerant, this temperature is converted into pressure pushing downward on the diaphragm, which opens the valve via push rods.
2. The suction pressure at outlet of evaporator coil is transferred via the external equalizer tube to underside of diaphragm.
3. The needle valve on pin carrier is spring-loaded, which also exerts pressure on underside of diaphragm via push rods, which closes valve. Therefore, bulb pressure equals evaporator pressure at outlet of coil plus spring pressure. If load increases, temperature increases at bulb, which increases pressure on top side of diaphragm, which pushes pin carrier away from seal, opening valve and increasing flow of refrigerant. The increased refrigerant flow causes increased leaving evaporator pressure which is transferred via the equalizer tube to underside of diaphragm, with which the pin carrier spring pressure closes valve. The refrigerant flow is effectively stabilized to load demand with negligible change in superheat.

The bi-flow TXV is used on split system heat pumps. In cooling mode, TXV operates the same as a standard TXV previously explained. However, when system is switched to heating mode of operation, refrigerant flow is reversed. The bi-flow TXV has an

additional internal check valve and tubing. These additions allow refrigerant to bypass TXV when refrigerant flow is reversed with only a 1- to 2-psig pressure drop through device. When heat pump switches to defrost mode, refrigerant flows through a completely open (not throttled) TXV. The bulb senses the residual heat of outlet tube of coil that had been operating in heating mode (about 85°F and 155 psig). This temporary, not throttled valve, decreases indoor pressure drop, which in turn increases refrigerant flow rate, decreases overall defrost time, and enhances defrost efficiency.

## I. PROBLEMS AFFECTING TXV

### A. Low Suction Pressure

1. Restriction in TXV
2. Low refrigerant charge
3. Low indoor load
4. Low evaporator airflow

### B. High Suction Pressure

1. Overcharging
2. Sensing bulb not secure to vapor tube
3. High indoor load
4. Large evaporator face area

When installing or removing TXV, wrap TXV with a wet cloth. When reattaching TXV, make sure sensing bulb is in good thermal contact with suction tube.

## PISTON BODY CLEANING OR REPLACEMENT

**CAUTION:** Do not vent refrigerant to atmosphere. Recover during system repair or final unit disposal.

**CAUTION:** Damage may occur to the scroll compressor if operated at a negative suction pressure during a system pumpdown.

1. Pump down outdoor unit. Close service valves at outdoor unit.
2. Recover remaining refrigerant from tubing and coil through gage port on vapor-tube service valve.
3. Disconnect refrigerant (liquid) tube from piston body. (See Fig. 29.)
4. Avoid damaging seal ring or machined surfaces on piston, bore, and retainer.
5. Using small wire with a hook on end of it, remove piston from body.

**CAUTION:** When cleaning the piston orifice, be careful not to scratch or enlarge the opening, as this will affect operation.

6. Install new or cleaned piston into body.
7. Replace seal ring on retainer.
8. Reconnect refrigerant tube to piston body.
9. Pressurize tubing and coil, then leak check.
10. Evacuate tubing and coil as necessary.

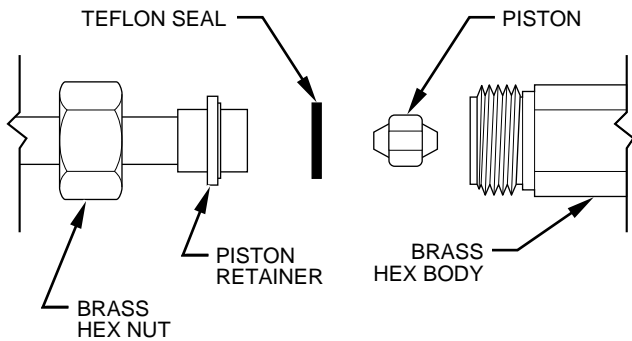

A93530

**Fig. 29—Refrigerant Flow-Control Device  
(For FA, FB, and FF)**

**CAUTION:** Use a backup wrench and do not over tighten, as deformation of the piston body will occur, causing the piston to lodge in a partially open or closed position.

### LIQUID TUBE STRAINER

The TXV and refrigerant flow-control device is protected on the indoor coil by a wire mesh strainer. It is located inside the 3/8-in. liquid tube at field braze joint just outside unit casing. Access to strainer is through field braze joint.

### COIL/CONDENSATE PAN REMOVAL AND REPLACEMENT

#### I. A-COIL UNITS

If it is determined that system does not have leaks and refrigerant is not contaminated, proceed as follows:

1. Recover system refrigerant.
  - a. Attach manifold/gage set to service valves.
  - b. Front seat (close) liquid tube service valve.
  - c. Start unit in cooling mode.
  - d. Run unit until vapor pressure reaches 5 psig (35kPa).
  - e. Turn off electrical supply to outdoor unit.
  - f. Front seat vapor service valve.
  - g. Recover any remaining refrigerant.

**NOTE:** All outdoor unit coils will hold only factory-supplied amount of refrigerant. Excess refrigerant, such as in long-tube applications, may cause compressor internal pressure relief valve to open (indicated by sudden rise in vapor pressure) before vapor pressure reaches 5 psig (35kPa). If this occurs, turn off electrical supply to outdoor unit immediately, front seat vapor service valve, and recover any remaining refrigerant.

2. Turn off electrical supply to indoor unit.
3. Disconnect condensate drain tube.
4. Disconnect liquid and vapor tubes from indoor coil. Use a tubing cutter to cut tubes.

**NOTE:** If a torch is used to unbraid tube set, protect fitting panel with a wet cloth or braze shield, as necessary.

5. Remove coil access panel.
6. Remove clip securing fitting panel to condensate drain pan. Remove fitting panel.
7. Remove any shipping clips, including horizontal pan clip, and slide coil/condensate pan assembly out of unit.
8. **Upflow or Horizontal Applications Only**—Remove horizontal condensate drain pan from coil/condensate pan assembly. (See Fig. 30.)

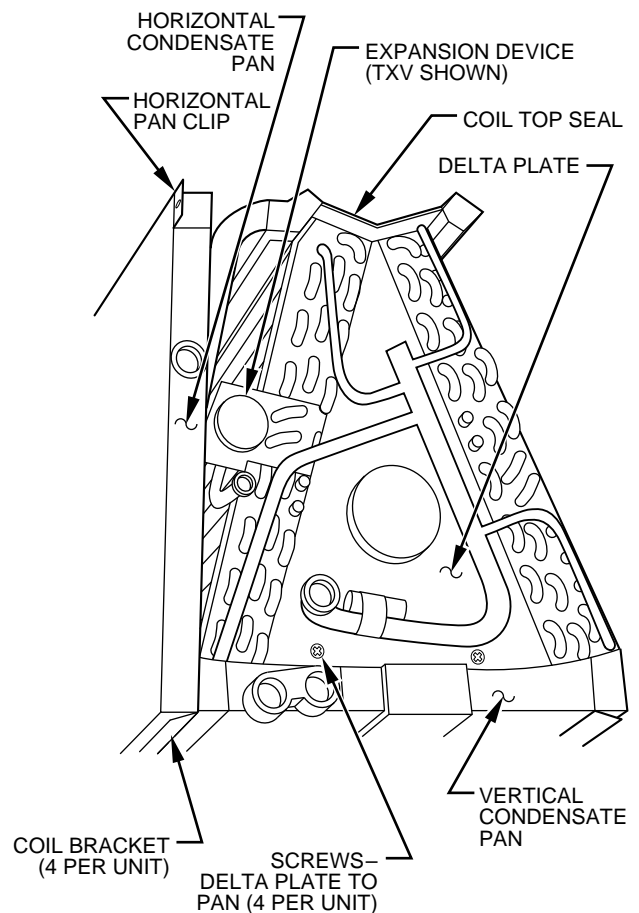

A90268

**Fig. 30—A-Coil Component Location**

9. Remove 4 coil brackets. (See Fig. 30.)
10. Remove screws at delta plates and remove coil from vertical condensate drain pan. (See Fig. 30.)
11. **Horizontal Applications Only**—Remove coil top seal (attached with 4 screws) and J-shaped tube from original coil and install it in same position on new coil. (See Fig. 30.)
12. Place coil assembly in plastic condensate pan and secure using 4 screws through delta plate. (See Fig. 30.)
13. **Horizontal and Upflow Applications Only**—Attach 4 coil brackets to coil/pan assembly. (See Fig. 30.)
14. **Horizontal Applications only**—Place horizontal condensate pan into position on coil/pan assembly.

**NOTE:** Installation of horizontal condensate pan is not necessary for upflow or downflow applications.

15. Slide complete assembly into unit.
16. Reinstall fitting panel and reconnect clip securing fitting panel to condensate drain pan.
17. **Horizontal Applications Only**—Reinstall horizontal pan clip. Secure with 1 screw. (See Fig. 30.)
18. Reinstall coil access panel.
19. Reconnect liquid and vapor refrigerant tubes, and condensate drain tube. Install filter-drier(s), if necessary.
20. Evacuate tube set and indoor coil, back seat (open) liquid and vapor service valves.
21. Turn on electrical supplies to indoor and outdoor units.
22. Check system refrigerant charge and operation. See "Split-System Residential Air Conditioners and Heat Pumps Service Manual" for further information.

## II. SLOPE COIL UNITS

If it is determined that system does not have leaks and refrigerant is not contaminated, proceed as follows:

1. Recover system refrigerant.
  - a. Attach manifold/gage set to service valves.
  - b. Front seat (close) liquid tube service valve.
  - c. Start unit in cooling mode.
  - d. Run unit until vapor pressure reaches 5 psig (35kPa).
  - e. Turn off electrical supply to outdoor unit.
  - f. Front seat vapor service valve.
  - g. Recover any remaining refrigerant.

**NOTE:** All outdoor unit coils will hold only factory-supplied amount of refrigerant. Excess refrigerant, such as in long-tube applications, may cause compressor internal pressure relief valve to open (indicated by sudden rise in vapor pressure) before vapor pressure reaches 5 psig (35kPa). If this occurs, turn off electrical supply to outdoor unit immediately, front seat vapor service valve, and recover any remaining refrigerant.

2. Turn off electrical supply to indoor unit.
3. Disconnect condensate drain tube.
4. Disconnect liquid and vapor tubes from indoor coil. Use either a tubing cutter to cut tubes or a torch to unbraid tubes as required.

**NOTE:** If a torch is used to unbraid line set, protect fitting panel with a wet cloth or braid shield, as necessary. System contains oil vapors which may ignite when exposed to a flame.

5. Remove coil access and fitting panels.
6. Remove 1 screw securing coil to unit casing.
7. Remove coil/pan assembly from unit.
8. Place assembly on a flat surface. Remove 2 screws securing coil support columns to pan. (See Fig. 31.)
9. Rotate columns 90°, pull away from coil, and remove columns from assembly.
10. Remove remaining 2 screws securing coil to condensate pan.

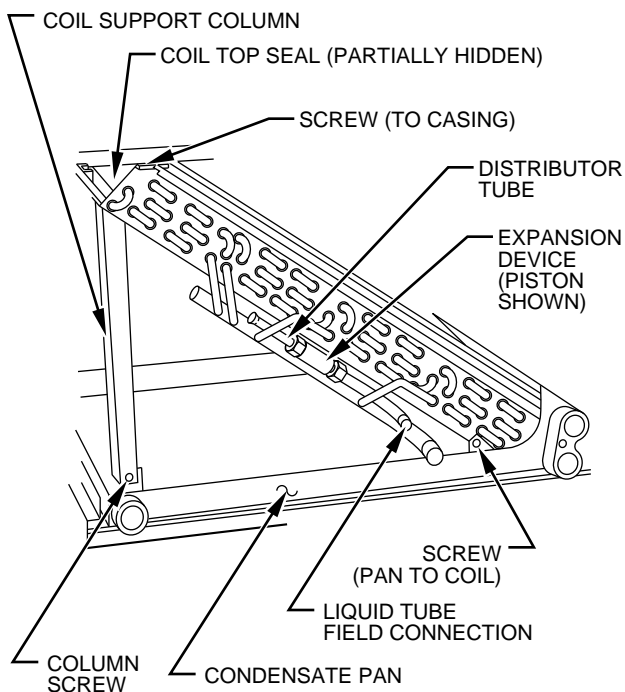

A90269

Fig. 31—Slope Coil Component Location

11. Remove coil from condensate pan.
12. Remove coil top seal. (See Fig. 31.)
13. Install new coil into condensate pan using 2 original screws and 2 support columns.

**NOTE:** Correct coil position in condensate pan is essential to reliable operation.

14. Install new coil/pan assembly into unit. Secure with 2 screws previously removed from unit casing.
15. Reinstall coil access and fitting panels.
16. Reconnect liquid and vapor refrigerant tubes, and condensate drain tube. Install filter-drier(s), if necessary.
17. Evacuate tube set and indoor coil, back seat (open) liquid and vapor service valves.
18. Turn on electrical supplies to indoor and outdoor units.
19. Check system refrigerant charge and operation. See "Split-System Residential Air Conditioners and Heat Pumps Service Manual" for further information.

## CARE AND MAINTENANCE

To continue high performance, and minimize possible equipment failure, it is essential periodic maintenance be performed on this equipment.

The ability to properly perform maintenance on this equipment requires certain mechanical skills and tools. The only consumer service recommended or required is filter maintenance. (See Filter Assembly.)

⚠	<p><b>WARNING:</b> Disconnect all power to the unit before servicing the field wires or removing the control package. The disconnect (when used) on the access panel does not disconnect power to the line side of the disconnect, but does allow safe service to all other parts of the unit. Electrical shock can cause personal injury or death.</p>
---	---

The minimum maintenance requirements for this equipment are as follows:

1. Inspect and clean or replace air filter each month or as required.
2. Inspect cooling coil, drain pan, and condensate drain each cooling season for cleanliness. Clean as necessary. An inspection port is provided on all A-coil delta plates. Remove plastic plug to inspect. Replace plug after inspection.
3. Inspect blower motor and wheel for cleanliness each heating and cooling season. Clean as necessary.
4. Inspect electrical connections for tightness and controls for proper operation each heating and cooling season. Service as necessary.

⚠	<p><b>WARNING:</b> As with any mechanical equipment, personal injury can result from sharp metal edges. Be careful when removing parts.</p>
---	---

## I. FILTER ASSEMBLY

To clean or replace air filter, push plastic connectors toward center of unit and remove filter access panel outward. Push filter up and back into unit. Then slide filter out. Clean filter by using cold water and mild detergent. Rinse and allow filter to dry. No oiling or coating of filter is required. New filters are available from your local distributor. Place filter in slot with cross-mesh binding up or facing cooling coil and replace filter access panel.

## II. COOLING COIL, DRAIN PAN, AND CONDENSATE DRAIN

The cooling coil is easily cleaned when it is dry. Inspect the coil and clean (if necessary) before each cooling season. To check or clean cooling coil, remove coil access panel. If coil is coated with dirt or lint, vacuum it with a soft brush attachment.

Be careful not to bend coil fins. If coil is coated with oil or grease, clean it with a mild detergent and water solution. Rinse coil thoroughly with clear water. Be careful not to splash water on insulation.

Inspect drain pan and condensate drain at the same time cooling coil is checked. Clean drain pan and condensate drain by removing any foreign matter from pan. Flush pan and drain tube with clear water.

If drain tube is restricted, it can generally be cleared by high-pressure water. Cut plastic line and work outside condensate pan and away from coil to clean drain tube.

⚠	<b>CAUTION:</b> Do not use caustic household drain cleaners in the condensate pan or near the coil. Drain cleaners can quickly destroy a coil.
---	--

## III. BLOWER MOTOR AND WHEEL

Clean blower motor and wheel when cooling coil is cleaned.

⚠	<b>CAUTION:</b> Disconnect electrical power before removing any access panels.
---	--

To clean blower motor or blower wheel:

1. Remove blower access panel.
2. Remove motor leads from PCB. Note lead location for ease of reassembly.
3. Remove 2 outside screws holding blower/motor assembly against blower-deck flange and slide assembly out of cabinet.
4. Remove screw in strap holding motor capacitor to blower housing and slide capacitor out from under strap. Remove screw with green wire from blower housing. Mark blower wheel, motor, and motor support in relation to blower housing before disassembly to ensure proper reassembly. Note position of blades on wheel.
5. Loosen setscrew holding blower wheel onto motor shaft.
6. Remove 3 bolts holding motor mount to blower housing and slide motor and mount out of housing. Further disassembly should not be necessary as adequate clearance is available.
7. Remove blower wheel from housing by removing cutoff plate from blower housing outlet. Note wheel orientation and cutoff location for reassembly. The blower motor and wheel may be cleaned by using a vacuum with a soft-brush attachment.
8. Remove grease with a mild solvent such as hot water and detergent. Be careful not to disturb balance weights (clips) on blower-wheel vanes. Also, do not drop or bend wheel, as balance will be affected.

To reassemble blower:

1. Place blower wheel back into housing. Be sure to position correctly for proper location.
2. Reassemble cutoff plate to housing using identified holes from disassembly procedure.
3. Position motor and mount in same position as when blower housing was in unit. Secure motor mount on housing, using removed bolts. Make sure mount or motor is grounded to blower housing.

4. Locate blower wheel setscrew over flat on motor shaft. Rotate wheel in housing. It should not rub housing and should be centered in inlet opening. If not, loosen setscrew and align as necessary.
5. Attach green wire to blower housing with screw.
6. Secure motor capacitor under strap and tighten strap screw.
7. Slide blower assembly to blower deck. Be sure (once blower is within the unit casing) to force blower assembly toward control box while sliding assembly into unit to ensure that blower assembly engages deck properly.
8. Fasten blower assembly to deck with screws previously removed.
9. Reconnect electrical leads to PCB.
10. Reconnect electrical power to unit and test fan for proper rotation.

## FF1A/FF1B/FF1C SERVICE AND TROUBLESHOOTING

⚠	<b>WARNING:</b> Before installation or servicing system, always turn off main power to system. There may be more than 1 disconnect switch. Turn off accessory heater power if applicable. Electrical shock can cause personal injury or death.
---	--

### I. FAN MOTOR

The motor is 2-speed direct drive. High-speed lead is black, low-speed lead is red, and common lead is violet. Be sure proper blower speed has been selected. For units with electrical heat, low-speed tap can be used. For cooling, use high-speed tap.

The motor is turned on through 2 different routes. The first occurs when thermostat calls for the fan in cooling, heat pump, or fan-only mode. A 24-vac signal is sent to relay, causing relay to close its normally-open contacts, turning fan on. The second occurs when there is a call for electric heat. A 24-vac signal is sent to heater sequencer, causing it to close, directing 230v through the normally-closed contact of fan relay, turning fan on. The fan remains on until sequencer opens. Refer to FF1A/FF1B/FF1C typical wiring diagram. (See Fig. 32.)

If motor does run, test motor for an open winding or a winding shorted to motor case. If any 1 of the 2 is present, replace motor.

### II. ELECTRIC HEATER SERVICE

Service can be completed with heater in place. Shut off power before servicing.

#### A. Limit Switch

Malfunction prevents heating element from coming on. Replace switch if malfunction occurs.

#### B. Sequencer

Malfunction causes heater not to come on or never shut off. Replace sequencer.

#### C. Transformer

A 40-va transformer supplies 24-v power for control circuit. Replace transformer if faulty.

**NOTE:** Transformer is fused. Do not short circuit.

#### D. Fan Relay

Malfunction causes unit fan not to run or run continuously. Replace relay.

### III. CLEANING OR REPLACING REFRIGERANT FLOW-CONTROL DEVICE

Refer to Fig. 29 and instructions given in Piston Body Cleaning or Replacement section above.

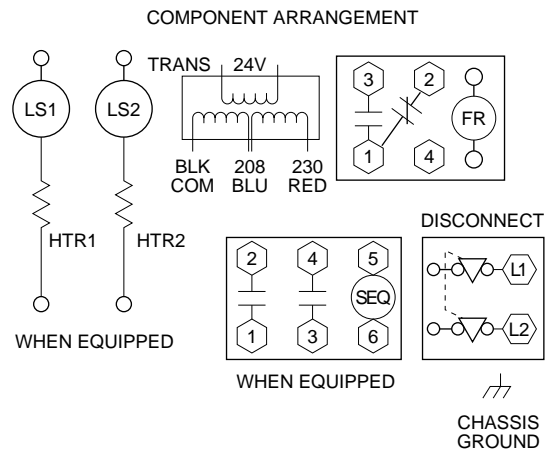
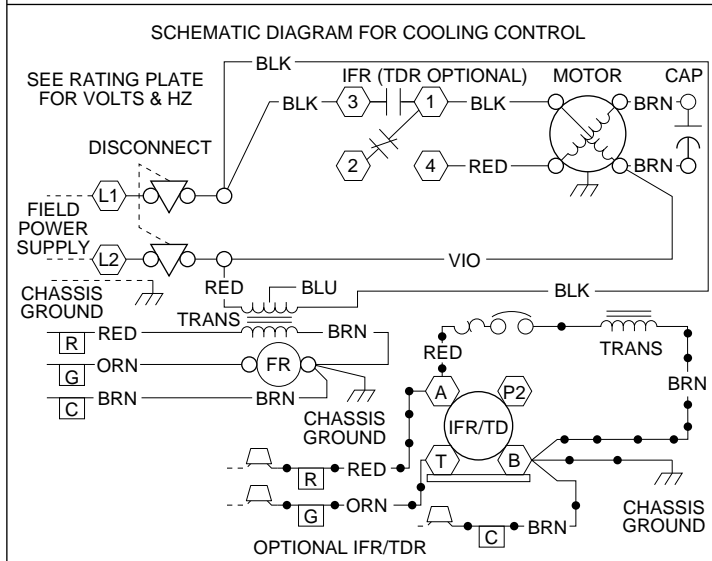
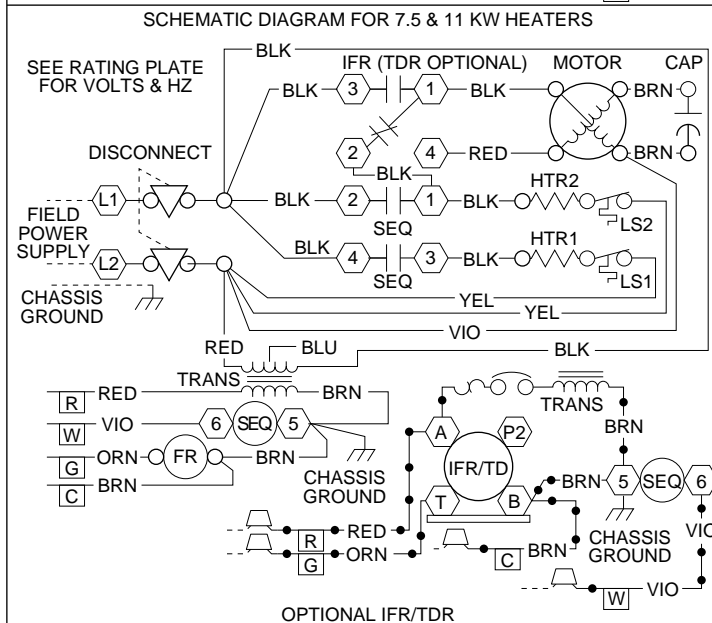
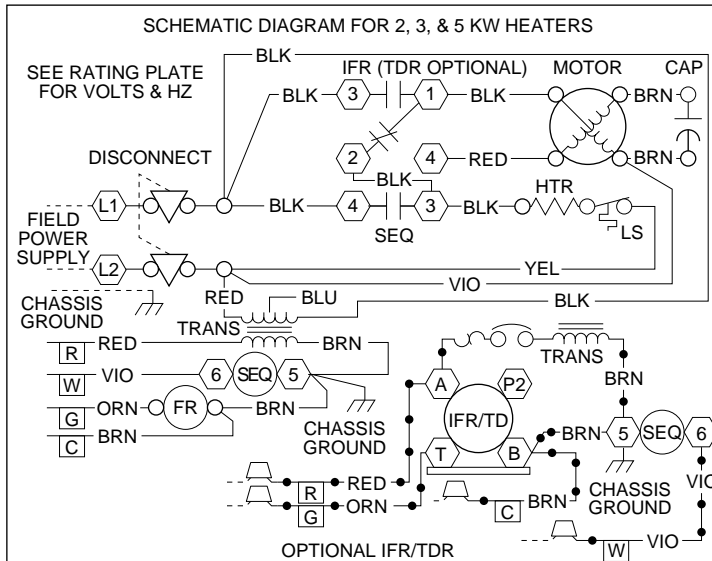

**MOTOR SPEED SELECTION**

HI = BLACK      LOW = RED      COMMON = VIO

HEAT PKG.	SIZE	TEMP. RATING
2 KW	14	90°C
3 KW	12	90°C
5 KW	10	90°C
7.5 KW	8	90°C
11 KW	6	90°C
0 (COOLING)	14	90°C

- LEGEND**
- MARKED TERMINAL
  - UNMARKED TERMINAL
  - LS LIMIT SWITCH
  - FR FAN RELAY
  - IFR INDOOR FAN RELAY
  - IFR/TD INDOOR FAN RELAY/TIME DELAY
  - SEQ SEQUENCER
  - CAP CAPACITOR
  - HTR HEATER
  - TRANS TRANSFORMER
  - FIELD POWER WIRING
  - OPTIONAL WIRING
  - FUSE
  - ⏏ CHASSIS GROUND

- NOTES**
1. UNIT WIRED FOR 230V OPERATION USING BLACK AND RED TRANSFORMER PRIMARY LEADS. FOR 208V OPERATION, USE BLACK AND BLUE TRANSFORMER PRIMARY LEADS.
  2. UNUSED TRANSFORMER LEADS MUST BE TAPED AND LOOPED.
  3. IF ANY OF THE ORIGINAL WIRE, AS SUPPLIED, MUST BE REPLACED, USE THE SAME OR EQUIVALENT WIRE.
  4. FIELD WIRING, USE COPPER CONDUCTORS, ONLY.
  5. FAN RELAY #4 IS A DEAD TERMINAL FOR UNUSED MOTOR LEAD STORAGE. TO CHANGE MOTOR SPEEDS, EXCHANGE THE BLACK AND RED MOTOR LEADS ON THE FAN RELAY.

**316596 - 401 REV. B**

**Fig. 32—FF1A/FF1B/FF1C Typical Unit Wiring Label**

## IV. LIQUID TUBE STRAINER

The refrigerant flow-control device is protected by a wire mesh strainer. It is located inside the 3/8-in. liquid tube at field braze joint next to flow-control device. Access to strainer is through field braze joint.

## V. SEQUENCE OF OPERATION

Refer to Fig. 32.

### A. Condensing Unit

#### COOLING

When thermostat calls for cooling, the circuit between R and G is complete and single-pole single-throw relay FR is energized. The normally-open contacts close causing blower to operate. The circuit between R and Y is also complete. This completed circuit causes contactor in outdoor unit to close which starts compressor and outdoor fan.

#### HEATING

When thermostat calls for heating and FAN switch is set on AUTO, the circuit between R and W is complete. The heater sequence SEQ is energized which closes contacts of relay. There will be a time delay. This completed circuit energizes all heating elements HTR and blower motor.

### B. Heat Pump

#### COOLING

On a call for cooling, the thermostat makes circuits R-O, R-Y, and R-G. Circuit R-O energizes reversing valve, switching it to cooling position. Circuit R-Y energizes contactor starting outdoor fan motor and compressor. Circuit R-G energizes indoor unit blower relay starting indoor blower motor. When thermostat is satisfied, its contacts open de-energizing contactor reversing valve and blower relay. This stops compressor and fan motors.

#### HEATING

On a call for heating, the thermostat makes circuits R-Y and R-G. Circuit R-Y energizes contactor starting outdoor fan motor and compressor. Circuit R-G energizes indoor blower relay starting blower motor. Should temperature continue to fall, R-W circuit is made through second-stage room thermostat bulb. Circuit R-W energizes a sequencer bringing on supplemental electric heat. When thermostat is satisfied, its contacts open de-energizing contactor and sequencer. All heaters and motors should stop.

## VI. CARE AND MAINTENANCE

The minimum maintenance requirements for this equipment are as follows:

1. Inspect and clean or replace air filter each month or as required.
2. Inspect cooling coil, drain pan, and condensate drain each cooling season for cleanliness. Clean as necessary.
3. Inspect blower motor and wheel for cleanliness each heating and cooling season. Clean as necessary.
4. Inspect electrical connections for tightness and controls for proper operation each heating and cooling season. Service as necessary.

 **WARNING:** As with any mechanical equipment, personal injury can result from sharp metal edges. Be careful when removing parts.

### A. Air Filter

To clean or replace air filter, grasp it at bottom and lift it out of unit. Clean filter using cold water. Rinse clean and let dry. Oiling or coating of filter is not required. To replace, stand filter in rack with binding facing coil. Press top edge under access panel.

**NOTE:** Steel rods in filter prevent it from being pulled into coil. Retain these rods and reinstall after cleaning or before replacement if new filter is used.

 **CAUTION:** Never operate unit without a filter.

### B. Cooling Coil, Drain Pan, and Condensate Drain

The cooling coil is easily cleaned when it is dry. Inspect coil and clean (if necessary) before each cooling season. To check or clean cooling coil, remove blower/heater access panel to gain full access to cooling coil. If coil is coated with dirt or lint, vacuum with a soft brush attachment.

Be careful not to bend coil fins. If coil is coated with oil or grease, clean it with a mild detergent-and-water solution. Rinse coil with clear water. Be careful not to splash water onto insulation.

Inspect drain pan and condensate drain at same time cooling coil is checked. Clean drain pan and condensate drain by removing any foreign matter from pan. Flush pan and drain tube with clear water. If drain tube is restricted, it can generally be cleared by high-pressure water. Cut plastic line and work outside condensate pan and away from coil to clear drain tube.

**NOTE:** There MUST be a trap in condensate line. Trap must be at least 3-in. deep, not higher than the bottom of unit condensate drain opening, and pitched downward to an open drain or sump.

 **CAUTION:** Do not use caustic household drain cleaners in condensate pan or near coil. Drain cleaners can quickly destroy coils.

### C. Blower Motor and Wheel

Clean blower motor and wheel when cooling coil is cleaned.

To clean or service wheel or motor, proceed as follows:

1. Pull unit disconnect (when used) and remove blower access panel.
2. Disconnect motor electrical leads from control box and capacitor. Mark location of wires for reassembly.
3. Remove 3 bolts holding motor mount to blower housing while supporting motor shell with hand.
4. Pull motor inlet ring and blower wheel assembly out of blower housing.
5. With blower wheel, inlet ring, and motor mount still attached to motor, place motor on flat, horizontal surface, shaft up. Mark position of wheel on motor shaft for reassembly.
6. Loosen blower wheel setscrew and remove blower wheel from motor shaft.

**NOTE:** Further disassembly of motor and mount is not necessary as adequate clearance is available to clean motor.

7. Clean blower motor and wheel using a vacuum with a soft brush attachment. Remove grease with a mild solvent such as hot water and detergent. Be careful not to disturb balance weights (clips) on blower wheel vanes. Do not drop or bend wheel as balance will be affected.

To reassemble unit, proceed as follows:

1. Place motor with mount attached on flat, horizontal surface with shaft up.
2. Set inlet ring on top of motor mount grommets. Center inlet ring flush on all 3 grommets.
3. Slide blower wheel onto motor shaft with setscrew upward and aligned with shaft flat portion. Vertically position wheel along shaft to position marked during disassembly.

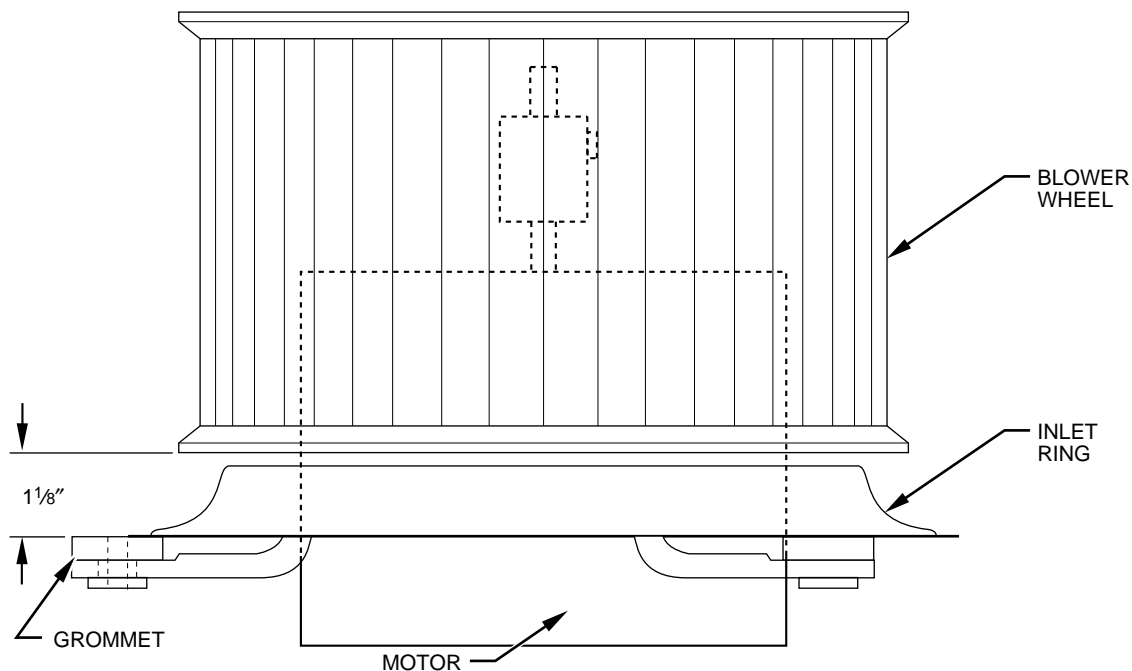

**Fig. 33—FF1A/FF1B/FF1C Motor, Inlet Ring, and Blower Wheel Assembly**

A86006

**NOTE:** If previous shaft was not marked or if replacing previous motor, set blower wheel position by sliding blower wheel along motor shaft to 1-1/8 in. above rubber grommets. (See Fig. 33.)

4. Hold blower wheel in place and carefully tighten setscrew.
5. Position motor and blower wheel assembly to blower housing as originally oriented.
6. Secure motor mount to blower housing using bolts previously removed.
7. Attach green wire to blower housing with screw.
8. Connect electrical and capacitor leads to original terminals.
9. Replace blower access door and tighten all 4 screws.
10. Reinsert disconnect pullout only after blower access door is secured. Test blower for proper operation.

### FD3A SERVICE AND TROUBLESHOOTING

⚠	<b>WARNING:</b> Before installation or servicing system, always turn off main power to system. There may be more than 1 disconnect switch. Turn off accessory heater power if applicable. Electrical shock can cause personal injury or death.
---	--

#### I. FAN MOTOR

The motor is 2-speed direct drive. High-speed lead is black, low-speed lead is red, and common lead is yellow.

**NOTE:** Unused fan speed leads must be tapped off to prevent direct short to cabinet surface.

The motor is turned on through 2 different routes. The first occurs when thermostat calls for the fan in cooling, heat pump, or fan-only mode. A 24-vac signal is sent to relay, causing relay to close its normally-open contacts, turning fan on. The second occurs when there is a call for electric heat. A 24-vac signal is sent to heater sequencer, causing it to close, directing 230v through the normally-closed contact of fan relay, turning fan on. The fan remains on until sequencer opens. Refer to FD3A typical wiring diagram. (See Fig. 34.)

#### II. ELECTRIC HEATER SERVICE

Service can be completed with heater in place. Shut off power before servicing.

#### A. Limit Switch

Malfunction prevents heating element from coming on. Replace switch if malfunction occurs.

#### B. Sequencer

Malfunction causes heater not to come on or never shut off. Replace sequencer.

#### C. Transformer

A 60-va transformer supplies 24-v power for control circuit. Replace transformer if faulty.

**NOTE:** Transformer is fused. Do not short circuit.

#### D. Fan Relay

Malfunction causes unit fan not to run or run continuously. Replace relay.

#### E. Heater Removal

Disconnect wiring, remove 2 sheet metal screws, and pull heater out through open hinged access panel. When replacing heater, ensure orientation of heater element is same as when removed.

### III. CLEANING OR REPLACING REFRIGERANT FLOW-CONTROL DEVICE

1. Pump down outdoor unit. Close service valves at outdoor unit.

⚠	<b>CAUTION:</b> Damage may occur to the scroll compressor if operated at a negative suction pressure during a system pumpdown.
---	--

2. Bleed and (if possible) recover remaining refrigerant from tubing and coil through gage port on vapor-tube service valve.
3. Disconnect liquid refrigerant tube from refrigerant flow-control device. Refer to Fig. 35.
4. Remove refrigerant flow-control device piston retainer. Avoid damaging O-ring or machined surfaces on piston, bore, and retainer.

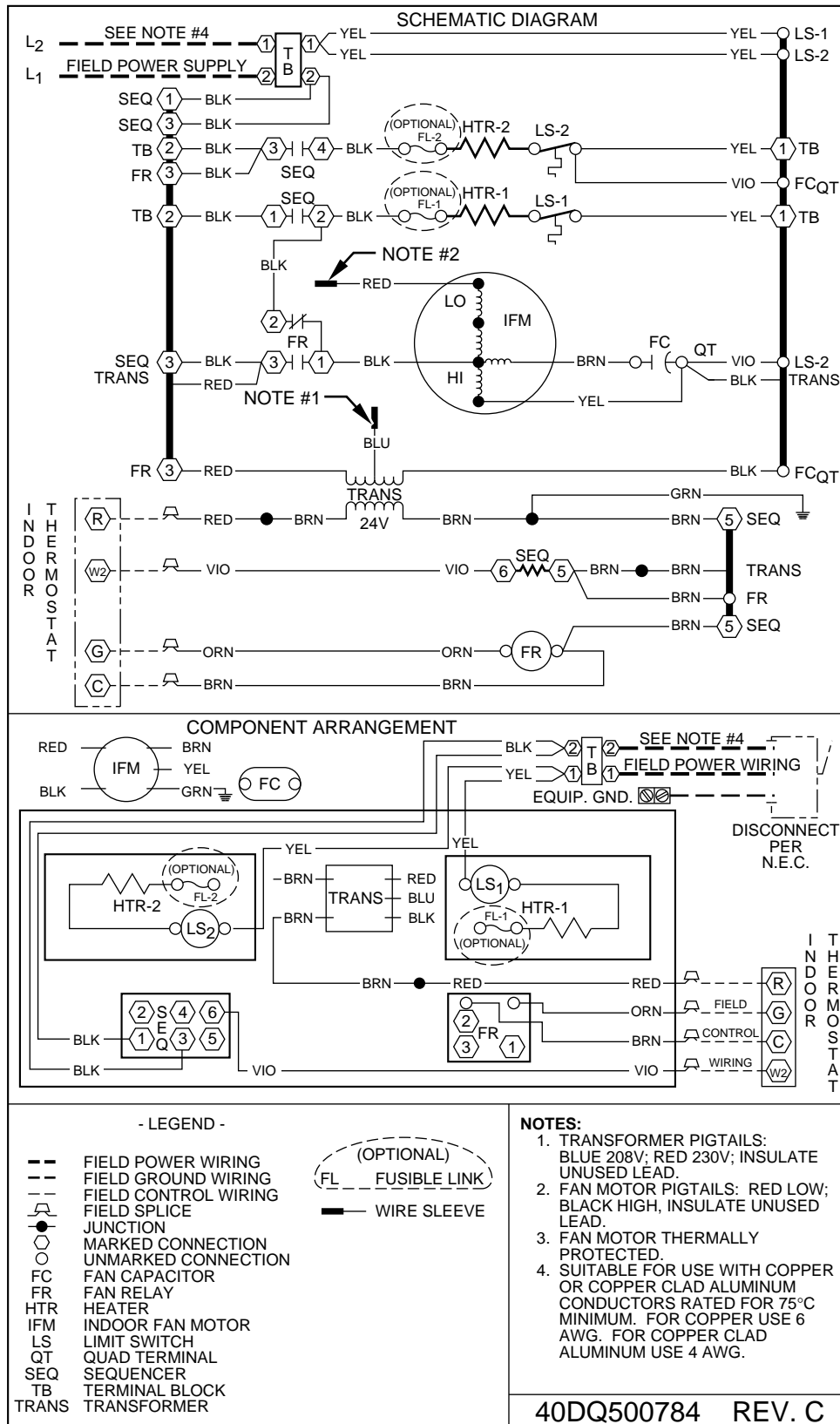
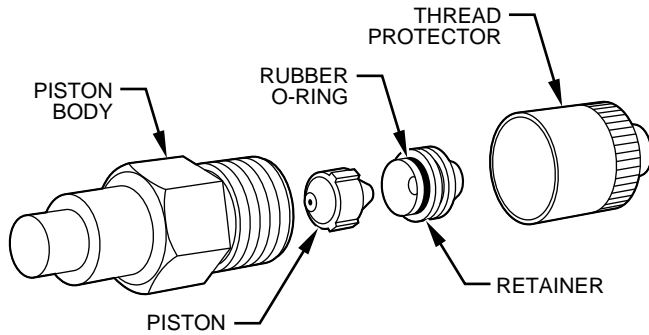

Fig. 34—FD3A Typical Wiring Diagram



- Using small wire with a hook on end of it, remove piston from refrigerant flow-control device body.



A92219

**Fig. 35—Refrigerant Flow-Control Device  
(For FD3A and FG3A)**

**CAUTION:** When cleaning piston orifice, be careful not to scratch or enlarge opening as this will affect operation.

**CAUTION:** Use a backup wrench and do not over-tighten as deformation of refrigerant flow-control device body will occur, causing piston to lodge in a partially open or closed position.

- Install new or cleaned piston in refrigerant flow-control device body.
- Install new retainer (because of probable damage which occurred in initial removal).
- Reconnect refrigerant tube to refrigerant flow-control device.
- Pressurize tubing and coil, then leak-check.
- Evacuate tubing and coil as necessary.

#### IV. LIQUID TUBE STRAINER

The refrigerant flow-control device is protected on indoor coil by a wire mesh strainer. If strainer becomes plugged:

- Complete items 1 and 2 under Cleaning or Replacing Refrigerant Flow-Control Device section.
- Loosen flare fitting joint connecting refrigerant flow-control device to coil liquid refrigerant tube.
- Remove sheet metal screw holding bracket clip in place. Screw is located between coil and refrigerant flow-control device.
- Pull bracket clip out.
- Remove refrigerant flow-control device assembly.
- Pull strainer out of coil liquid refrigerant tube and replace with new strainer.

#### V. CARE AND MAINTENANCE

**WARNING:** Hinged access panel contains electrical components and is heavy. Support panel when lowering to clean unit to avoid personal injury.

**WARNING:** Disconnect electrical power to all circuits before servicing unit. Failure to do so may result in personal injury from electrical shock or moving parts.

**WARNING:** As with any mechanical equipment, personal injury can result from sharp metal edges. Be careful when removing parts.

The minimum maintenance requirements for this equipment are as follows:

- Inspect and clean or replace field-supplied air filter each month or as required.
- Inspect cooling coil, drain pan, and condensate drain each cooling season for cleanliness. Clean as necessary. (To be performed by trained personnel.)
- Inspect blower motor and wheel for cleanliness each heating and cooling season. Clean as necessary.
- Inspect electrical connections for tightness and controls for proper operation each heating and cooling season. Service as necessary.

**NOTE:** Never operate without a filter or with hinged access door open. Damage to blower motor may result.

#### A. Cooling Coil, Drain Pan, and Condensate Drain

Remember to disconnect electrical power before opening hinged access panel.

The cooling coil is easily cleaned when dry. Inspect coil and clean (if necessary) before each cooling season. If coil inlet face is coated with dirt or lint, vacuum with a soft brush attachment.

Be careful not to bend coil fins. If coil is coated with oil or grease, clean it with a mild detergent-and-hot water solution. Rinse coil with clear water. Be careful not to splash water onto insulation. Inspect drain pan and condensate drain at same time cooling coil is checked. Clean drain pan and condensate drain by removing any foreign matter from pan. Flush pan and drain tube with clear water. Clear drain line if restricted.

**NOTE:** There MUST be a trap in condensate line. Trap must be at least 3-in. deep, not higher than the bottom of unit condensate drain opening, and pitched downward to an open drain or sump.

#### B. Blower Motor and Wheel

Clean blower motor and wheel when cooling coil is cleaned. Lubricate motor every 5 years if motor is used on intermittent operation (thermostat FAN switch at AUTO position), or every 2 years if motor is in continuous operation (thermostat FAN switch at ON position). Remove motor to lubricate. Put approximately 8 drops of SAE 10 nondetergent oil in each oil hole. Do not overoil motor. Plug hole securely so that oil does not drip when hinged access panel is lowered to open position.

Blower motor and wheel may be cleaned using a vacuum with a soft brush attachment. Remove grease with a mild solvent such as hot water and detergent. Be careful not to disturb balance weights (clips) on blower wheel vanes. Do not drop or bend wheel as balance will be affected.

### FG3A SERVICE AND TROUBLESHOOTING

#### I. SERVICE

##### A. Motor

Ball bearing oilers are provided on blower motor. Use electric motor oil or SAE 10 or 20 nondetergent oil. Check motor mount bracket and base bolts. Tighten as required.

##### B. Blower

Check ball bearings for wear. Ball bearings are self-aligning and grease packed. Replace as required. Check thrust collars for end play and alignment of wheel. Check blades for accumulation of dirt. Clean as required. Check mounting brackets, base bolts, and isolation material.

See Fig. 36 for diagram of internal wiring for blower coil assembly. Control box (standard 4-in. junction box) is mounted on refrigerant connection side of unit. All leads pass through strain relief where they enter control box. Wiring inside cabinet is located so it does not come in contact with moving parts or sharp edges.

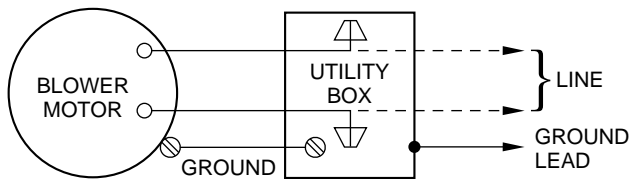

A91151

Fig. 36—Wiring Schematic

### C. Pulley and Belts

Check belt tension and pulley alignment. (See Fig. 37.) Belt tension is adjusted by motor tailpiece bolt. A deflection of about 3/4 in. to 1 in. per foot of span should be obtained by pressing belt firmly. Lock adjusting bolt in position after adjustment is made. Align pulley grooves by locating motor pulley on motor shaft or by moving entire motor along motor mounting bracket. Adjust blower speed by loosening setscrew in outer (moveable) pulley face and turning this face (half or full turns) so that adjusting setscrew is positioned precisely over the flat on pulley hub. Speed is reduced by adjusting pulley faces so they are further apart; speed is increased with faces closer together. Check pulley setscrews and bolts.

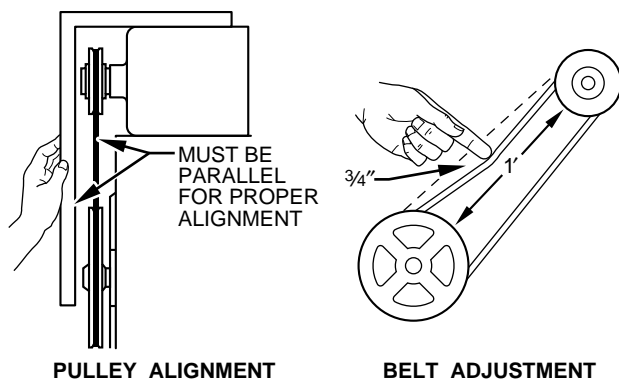

A91150

Fig. 37—Checking Pulley Alignment and Tightness

### D. Cleaning or Replacing Refrigerant Flow-Control Device

Refer to Fig. 35 and instructions given in FD3A Service and Troubleshooting section above.

## II. MAINTENANCE

**WARNING:** Disconnect electrical power to all circuits before servicing unit. Failure to do so may result in personal injury from electrical shock or moving parts.

**WARNING:** As with any mechanical equipment, personal injury can result from sharp metal edges. Be careful when removing parts.

### A. Return-Air Filter

To clean or replace air filter, remove screws and filter access door. Slide out filter. For washable type filters, clean with hot soapy water. Rinse clean and let dry.

New filters are available from a local distributor. Place filter in slot with filter arrow facing direction of airflow. Replace filter access doors with screws previously removed.

**CAUTION:** Never operate unit without a filter or with filter access door removed. Damage to blower motor may result.

### B. Coil, Drain Pan, and Condensate Drain

**CAUTION:** Disconnect electrical power before removing any access panels or electrical shock may result.

The coil is easily cleaned when dry. To check or clean coil, remove coil access panel. If coil is coated with dirt or lint, vacuum with a soft brush attachment.

Be careful not to bend fins. If coil is coated with oil or grease, it may be cleaned with mild detergent and water solution. Rinse coil with clean water. Be careful not to splash water on insulation or filter.

Check drain pan and condensate drain at same time cooling coil is checked. Clean drain pan and condensate drain by removing any foreign matter from pan. Check for rust and holes. Flush pan and drain tube with clear water. If drain is restricted, clean with high-pressure water. If this does not work, use a plumber's snake or similar probe device. Repitch drain pan to promote proper drainage.

## FA4A, FB4A, AND FC4B SMART HEAT CIRCUIT BOARD FUNCTION AND TROUBLESHOOTING

### I. PCB COMPONENT LAYOUT, DESCRIPTION, AND FUNCTION

**NOTE:** All voltages are AC unless otherwise specified.

1. The low-voltage terminal board is used to connect indoor thermostat to low, 24-v side of transformer and to serve as a junction between indoor thermostat and outdoor section.
  - a. R terminal is used to connect secondary side of transformer to thermostat and outdoor unit. R is fused.
  - b. C terminal is used to connect transformer secondary common for thermostat and outdoor unit.
  - c. Y terminal provides input signal from thermostat signaling heat pump operation.
  - d. G terminal provides input signal from thermostat signaling continuous fan operation.
  - e. O terminal provides input and junction terminal for reversing valve signal.
  - f. W2D terminal provides input from outdoor unit (heat pump) signaling control board that heat pump is in defrost.
  - g. W2T terminal provides input from thermostat signaling for supplemental or emergency heat.
  - h. W3 terminal provides input from outdoor thermostat. W3 and W2T are factory connected by JW1. This input is used only if an outdoor thermostat is required by local codes.
  - i. Y<sub>o</sub> terminal provides output from control board to energize outdoor unit (heat pump) contactor.
2. Jumper wires (JW1 and JW2). (See Fig. 38.)
  - a. JW1 connects W2T to W3 to limit staging of electric heat with use of an outdoor thermostat. See Table 11 for staging. Smart Heat PCB controls staging to the extent that this feature is unnecessary unless required by local codes or regulations.

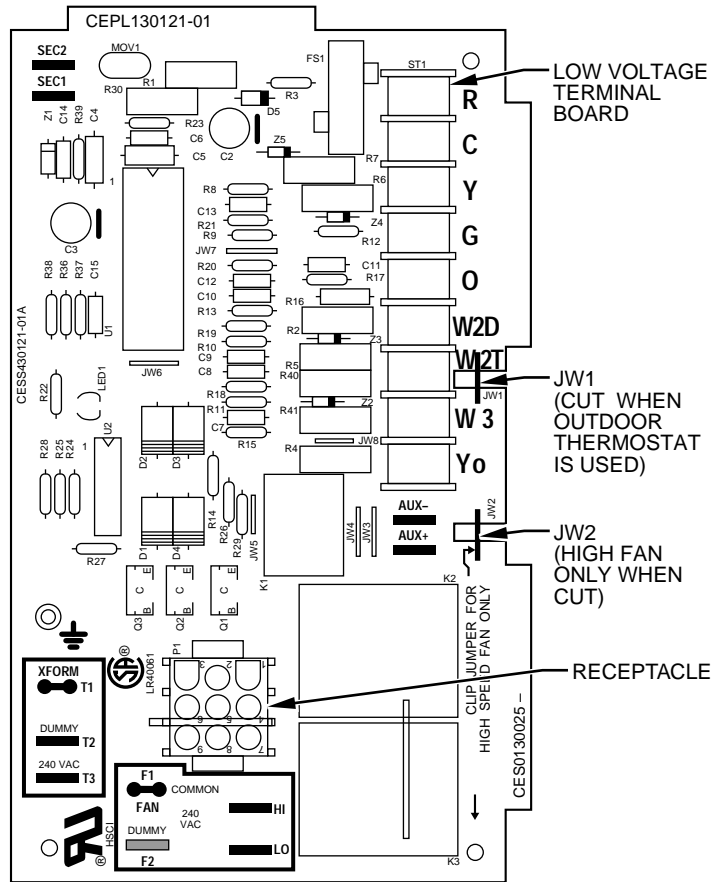

Fig. 38—Smart Heat Printed-Circuit Board (PCB)

A94127

- b. Cutting JW2 sets Smart Heat PCB in efficiency mode. With JW2 cut, there is no loss of performance due to reduced indoor blower speed when heat pump is operating near balance point. This jumper may need to be cut if selected cooling fan speed is the same as required minimum motor LO speed tap selection. With JW2 cut, fan terminal LO becomes a dummy terminal.
3. A fuse is used to protect low-voltage transformer and PCB.
4. AUX+ and AUX- are connections for air conditioning accessories (EAC, humidifier, etc.).
5. F1, F2, HI, and LO are connections for indoor fan.
6. The 9-pin receptacle connects heater package wiring harness.
7. SEC1 and SEC2 are used to connect secondary side of transformer to PCB. SEC1 is connected to equipment ground.

## II. UNIT FUNCTIONS

### A. Transformer

**NOTE:** Terminals T1, T2 (if used), and T3 are wired to primary or high side of transformer. The 208-v terminal (or blue wire if transformer has primary leads) is used on T3 for 208-v applications. The 230-v terminal (or red wire) is used on T3 for 230-v applications. T2 is a dummy terminal.

### B. Electric Heat

**NOTE:** When troubleshooting elements, position thermostat to emergency heat. Wait approximately 12 minutes for all elements to come on.

1. When thermostat calls for electric heat, a 24-v signal is sent to PCB through W2T. The PCB energizes first stage of electric heat.

2. The first 2 stages come on if W2T and Y are energized at the same time. After each 10 minutes W2T is energized, another stage of electric heat is energized.
3. As W2T is de-energized, electric heat stages down in 8 minute steps with the exception of first step. The first step will be on only half as long as it was prior to W2T de-energizing.
4. When W2T is energized by itself, JW1 is cut, and an outdoor thermostat is used and is open, staging is limited as in Table 11.
5. When both W3 and W2T are energized without JW1 being cut or with outdoor thermostat closed, system operation stages heat up to maximum level if signal is energized for proper amount of time.
6. If only W3 is energized, there is no effect on PCB. No heat is energized.

### C. Accessories

Terminals AUX+ and AUX- are energized with 24 vdc when fan is energized. The accessory kit KFAIR0101ACR is used to connect an EAC or humidifier.

**NOTE:** Loads cannot be connected directly to AUX+ and AUX-. Use the specified kit only.

### D. Blower

1. Blower On Delay—To optimize comfort, there is a 30-sec blower on delay in heat pump heating mode only.
2. Blower Off Delay—Smart Heat control uses a 60-sec off blower delay, as opposed to the standard 90-sec delay.

## III. SMART HEAT OPERATION

### A. Cooling

The Smart Heat option controls cooling mode in same manner as conventional heat pumps are controlled. The fan has a 90-sec delay off/on cycle down.

**TABLE 10—ELECTRIC HEATER STAGE LIMITING**

HEATER PART NO.	Heater Stage	STAGES (KW OPERATING)			
		W2T Only (JW1 cut)		W2T and W3	
		1	2	3	4
<b>KFAEH2201H10</b>	10 kw Non-Fused	3	6	9	9
<b>KFAEH2301H15</b>	15 kw Fused	3	8	11	15
<b>KFAEH2401H20</b>	20 kw Fused	5	10	15	20

**B. Heat Pump Heating**

The Smart Heat option does not control heating in the conventional method. The PCB energizes compressor 30 sec before indoor fan is energized. This allows indoor coil to heat up eliminating cold-blow on start-up.

The electric heat is staged-on to allow continuous operation of heat pump and electric resistance heat below balance point (below point where heat pump cannot maintain dwelling temperature without supplemental heat) independent of outdoor thermostats.

Although PCB has provisions for an outdoor thermostat, it is not needed for staging. On cycle down, indoor fan remains on 60 sec to recover heat stored in indoor coil.

**C. Defrost**

The Smart Heat PCB stages the correct amount of supplemental heat during defrost. If too much heat is added, system stays in defrost for completion of defrost cycle even though thermostat is satisfied. On next cycle, 1 less element is energized during next defrost period.

**NOTE:** If 24-v power from thermostat is interrupted while unit is in defrost mode, the default cycle will be completed before unit shuts down.

**D. Troubleshooting Printed-Circuit Board (Diagnostic LED)**

The PCB of Smart Heat option heater package contains a micro-processor which controls fan operation, fan speed, outdoor unit, and heater elements. For troubleshooting, a service LED indicates condition of PCB. See Table 11 for LED flash codes.

**TABLE 11—LED CODES FOR SMART HEAT PCB**

FLASH CONDITION	INPUT SIGNALS	SYSTEM OPERATION
No Light/Flash	—	No Power or Board Failure
Steady Light	—	Board Failure
Steady Flash	—	Stand By Condition or Fan Only
1 Flash	Y only	Heat Pump Only Operating
2 Flashes	Y and/or W2T	Heat Pump Plus 1 Sequencer
3 Flashes	Y and/or W2T	Heat Pump Plus 2 Sequencers
4 Flashes	Y and/or W2T	Heat Pump Plus 3 Sequencers
5 Flashes	Y, O	Cool Mode
6 Flashes	Y, W2D, and/or W2T	Defrost Mode
7 Flashes	W2T	Emergency Heat Mode

**IV. ELECTRICAL OPERATING SEQUENCES AND TROUBLESHOOTING**

**NOTE:** Refer to Table 12 for proper input and output voltages.

**A. Ready-To-Start**

In ready-to-start (standby) mode, LED on board indicates a steady flash.

In this mode, 24-v power should be available at control’s low voltage terminal strip terminals R and C. If 24v is not present across R and C, check the following:

- Is low-voltage fuse on control board good?
- Are line voltage fuses FU1 and FU2 good?
- Is LED on control on steadily or not on at all? Both of these indications signal a possible board failure.
- Is 208/230-v power available to control across pins 7 and 9 of 9-pin connector? Is connection to board tight?

**B. Continuous Fan**

On a call for continuous fan, thermostat provides a 24-v input signal to G terminal on low-voltage terminal strip. Sensing this signal, the microprocessor energizes a relay on control to provide power to high-speed winding of fan motor, at 1. The fan continues to run until fan switch on thermostat is turned off.

During continuous fan operation with no call for heating or cooling, LED indicates a steady flash, the same indication seen when system is in standby.

The call for continuous fan operation signal can be checked by placing voltmeter leads across terminals G and C of control’s low-voltage terminal strip. If 24v is not seen across these terminals, check for the following:

- Is 24v available across R and C? If not, refer to Ready-To-Start section for items to check if 24v is not available.
- Is thermostat function switch set for continuous operation?

Confirm fan operation. Voltage to operate fan can be confirmed by placing voltmeter leads across terminals F1 and HI on control. The reading should be 208/230v. If 208/230v is not observed, check the following:

- Is 208/230v available at pins 7 and 9 of 9-pin connector? Is connection to board tight?
- Are line voltage fuses FU1 and FU2 good?

If 208/230v is available across terminals F1 and HI and fan does not operate, check the following:

- Is fan motor capacitor good?
- Is blower wheel jammed or loose? Are there any other mechanical problems preventing fan operation?

**C. Cooling**

On a call for cooling, room thermostat provides input signals to control board at terminals Y and O. The O signal is also available to heat pump to energize reversing valve.

When it receives both these signals, the microprocessor responds by providing a 24-v output signal at the Y<sub>o</sub> terminal. This output signal energizes contactor in heat pump and starts compressor. There is a 3 to 5 sec delay in output of Y<sub>o</sub> signal.

At the same time, control energizes fan coil’s fan motor on high speed through terminals F1 and HI. The LED indicator on control signals 5 flashes, indicating cooling operation.

The call for cooling signals can be confirmed by placing voltmeter leads across low-voltage terminals Y, O, Y<sub>o</sub>, and C. The reading should be 24v. If 24v is not available, check the following:

- Is 24v available across R and C? See Ready-To-Start section for items to check if 24v is not available.
- Is thermostat function switch set in COOL position with thermostat calling for cooling?

Assuming heat pump has power and is adequately charged, it should be running at this time in cooling mode. Indoor fan should also be running at this time. If indoor fan is not running, refer to Continuous Fan section for items to check.

**TABLE 12—TROUBLESHOOTING VOLTAGE READINGS AND TEST POINTS**

**INPUT VOLTAGES**

LOCATION	NORMAL READING	PURPOSE
L1 and L2	208/230 vac	Main power supply input to fan coil
L3 and L4	208/230 vac	Power to electric heaters
9-pin connector 7 and 9	208/230 vac	Power to smart control
T1 and T3	208/230 vac	Power to transformer
SEC1 and SEC2	24 vac	Power from transformer secondary
R and C	24 vac	Power from transformer secondary
G and C	24 vac	Call for continuous fan signal from room thermostat
Y and C	24 vac	Call for heat/cool signal from room thermostat
O and C	24 vac	Signal to energize reversing valve from room thermostat (cooling). Also present during defrost.
W2T and C	24 vac	Call for electric heat from room thermostat
W2D and C	24 vac	Defrost initiation signal from heat pump

**OUTPUT VOLTAGES**

LOCATION	NORMAL READING	PURPOSE
H1 and F1	208/230 vac	Power to blower motor (high speed)
LO and F1	208/230 vac	Power to blower motor (low speed)
Y <sub>o</sub> and C	24 vac	Power to energize contactor in heat pump (heat and cool modes)
9-pin connector 1 and 4	24 vdc	Power to energize SEQ 1 NOTE: Sequencers use DC voltage
9-pin connector 2 and 4	24 vdc	Power to energize SEQ 2
9-pin connector 3 and 4	24 vdc	Power to energize SEQ 3

vac—volts AC  
vdc—volts DC

**D. Heating (Compressor Only)**

On a call for heat, room thermostat provides an input signal to control board at terminal Y. This signal causes the microprocessor to provide a 24-v output signal at terminal Y<sub>o</sub> to energize contactor in heat pump. There is a 3 to 5 sec delay in output of Y<sub>o</sub> signal.

Thirty sec after Y is energized, control energizes fan motor. It may run on high or low speed, depending on its operation in previous cycle.

Compressor operation in current cycle is monitored by the smart control to determine whether a fan speed change is required for enhanced indoor comfort. The LED indicator on control signals 1 flash, indicating compressor operation only with no electric heat.

The call for heat signals can be confirmed by placing voltmeter leads across low-voltage terminals Y, Y<sub>o</sub>, and C. The readings should be 24v. If 24v is not available, check the following:

- Is 24v available across R and C? See Ready-To-Start section for items to check if 24v is not available.
- Is thermostat function switch set in HEAT position with thermostat calling for heat?

Assuming heat pump has power and is adequately charged, it should be running at this time in heating mode. Indoor fan should also be running at this time. If indoor fan is not running, refer to Continuous Fan section for items to check. When room thermostat is satisfied, indoor fan continues to run an additional 60 sec to recover heat remaining in indoor coil.

**E. Heating (Compressor and Electric Heat)**

If heat pump alone cannot satisfy heat requirements of structure, room thermostat calls for additional heat by way of an input to W2 terminal of control. When this occurs, control begins sequencing on electric heaters by energizing the first sequencer. Indoor fan should be running at this time.

If room temperature requirements cannot be met, additional stages of electric heat are energized through the other 2 sequencers, at 2.

The logic of control determines how much and how soon these additional stages are brought on. By observing LED status light, the number of operating stages of electric heat can be determined. The control also varies indoor fan speed depending on number of energized stages of heat. In general, the more stages of electric heat, the higher the fan speed.

There is no hard and fast rule for determining exactly when stages will be energized since microprocessor in the smart control constantly monitors duration of previous heating cycle, setting of room thermostat, and number of stages of heat needed in previous cycle to satisfy room thermostat. Rather than try to determine what should be operating when, service technicians should check LED status light to see how many stages of electric heat are energized at a given time and confirm operation of sequencer using a voltmeter. If a quick check of all stages is desired, set room thermostat as high as it will go. With a constant signal on W2T terminal, sequencers energize every 10 minutes until all heaters are on.

The previous paragraphs described how to check for low-voltage inputs to control by placing voltmeter leads across low-voltage terminal strip and checking for 24v. The call for electric heat can be confirmed by placing voltmeter leads across W2T and C.

To check for operation of sequencers, check directly across appropriate sequencer coil for 24 volts DC.

**NOTE:** All sequencer coils are powered by 24 volts DC. This voltage is generated internally by the smart control.

In this example, sequencer 1 is being checked. The procedure is the same for all other sequencers. If 24 volts DC is not observed, check the following:

- Is room thermostat calling for electric heat? This can be confirmed by checking for 24 volts AC between low-voltage terminal strip terminals W2T and C.

- Is LED flashing appropriate code for number of sequencers energized? In this example, 2 flashes should be visible, indicating 1 sequencer is energized. Indicator tells how many sequencers are energized, but does not tell which ones are.

- Is 9-pin connector for heater package tightly secured to control board?

**F. Checking Sequencer Operation**

To check for operation of power circuit of sequencer, place voltmeter leads across sequencer terminal 1 of sequencer 1 and terminal 4 of limit switch 3. The reading should be 208/230v, and heater should be energized.

If 208/230v is not observed at terminals specified, check the following:

- Are fuses FU3 and FU4 good?
- Is limit switch LS3 open? If so, check fan coil air filter or air distribution system for blocking or restriction that might reduce airflow and cause limit switch to open.

Operation of heaters can be confirmed further by using a clamp-on ammeter in circuit shown to verify current is flowing through heaters. Amperage readings will depend on size of heater. The procedure for checking other sequencers in system is identical to that just described.

**G. Emergency Heat**

Emergency heat mode requires that room thermostat be placed in EMERGENCY HEAT position. This locks out and prevents operation of heat pump outdoor unit. In this mode, heat is provided exclusively by electrical heaters in fan coil.

In this mode, room thermostat, at 1, provides an emergency heat input signal to smart control at terminal W2T. If jumper JW1, at 2, has not been cut and an outdoor thermostat installed to control electric heat stages, that same input signal is applied to terminal W3. For this example, assume that jumper JW1 has not been cut.

Eventually, the total number of heaters is cycled on. In emergency heat mode, LED indicator signals 7 flashes.

The amount of emergency heat available depends on whether jumper JW1 is cut and the number of heating elements. Table 13 illustrates results under various conditions. The heaters cycle on every 5 minutes until maximum level is reached.

**TABLE 13—EFFECT OF JW1 ON EMERGENCY HEAT**

JW1 cut*	
4 elements	3 elements
50%	66.7%
JW1 not cut	
4 elements	3 elements
100%	100%

\* Outdoor thermostat opens

With JW1 cut, an outdoor thermostat (if closed) could cycle on additional heaters and system would perform as if JW1 was not cut. In effect, closed outdoor thermostat replaces cut jumper.

**H. Defrost**

In defrost mode, LED indicator signals 6 flashes. Defrost is initiated by heat pump and is signalled to smart control by an input to W2D terminal. During defrost, outdoor unit switches to cooling mode, making it necessary to cycle on electric heaters to temper indoor air.

If electric heaters were not energized prior to defrost, smart control energizes sufficient elements to temper air. If heaters were energized prior to defrost, additional heaters may or may not be cycled on to provide additional heat.

A defrost initiation signal can be confirmed by attaching voltmeter leads across low-voltage terminals W2D and C. If 24v is not observed, check the following:

- Is 24v available across R and C? See Ready-To-Start section for items to check if 24v is not available.
- Is there continuity in thermostat leads between heat pump and smart control?
- Is defrost control in heat pump operating properly?

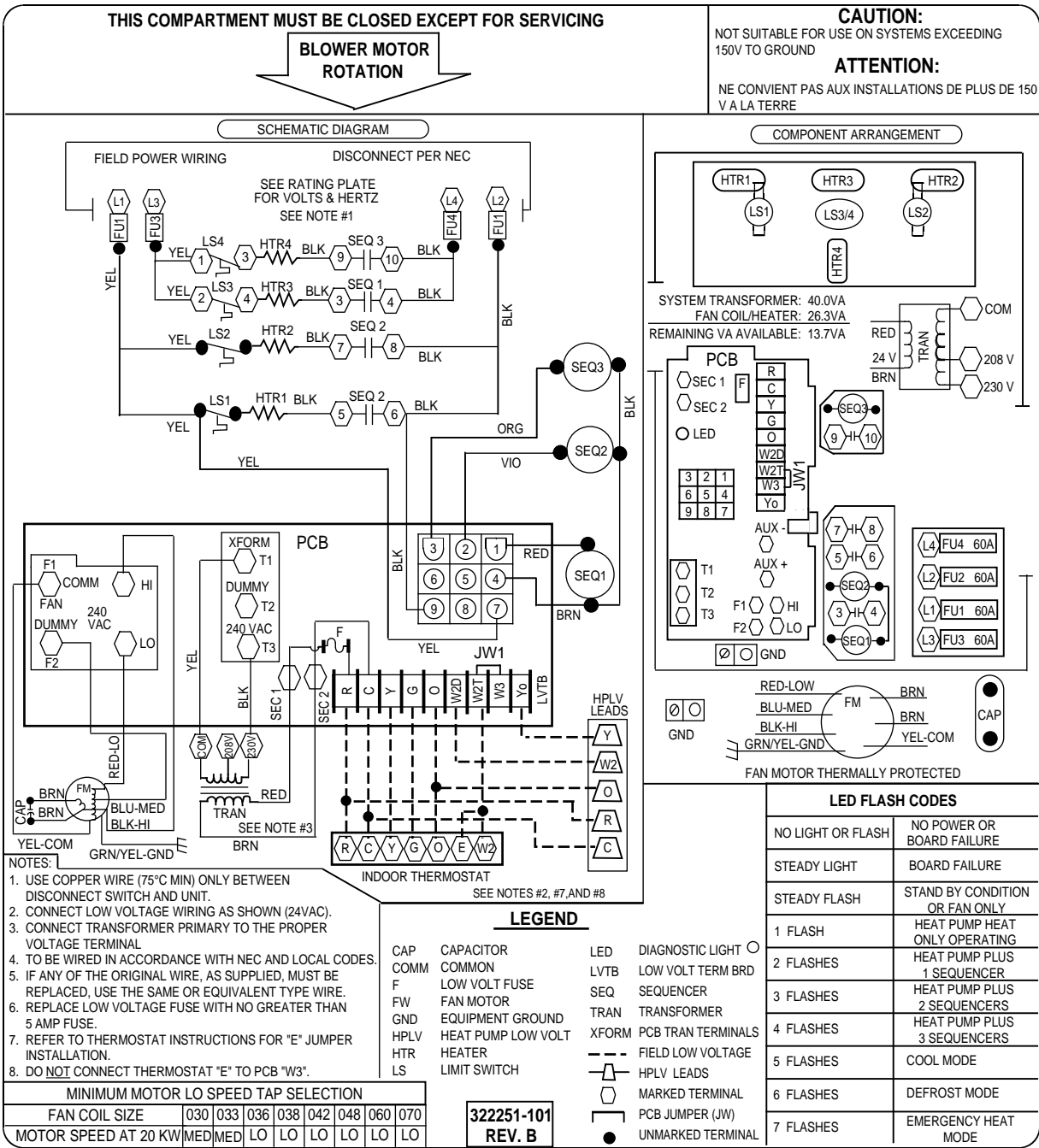

**Fig. 39—Smart Heat Typical Wiring Diagram (Motor Speed at 20kw Shown)**

A94132

# SERVICE TRAINING

**Packaged Service Training** programs are an excellent way to increase your knowledge of the equipment discussed in this manual, including:

- Unit Familiarization
- Maintenance
- Installation Overview
- Operating Sequence

A large selection of product, theory, and skills programs is available, using popular video-based formats and materials. All include video and/or slides, plus companion book.

**Classroom Service Training** plus "hands-on" the products in our labs can mean increased confidence that really pays dividends in faster troubleshooting, fewer callbacks. Course descriptions and schedules are in our catalog.

**CALL FOR FREE CATALOG 1-800-962-9212**

Packaged Service Training

Classroom Service Training

A94328