

Installation Instructions

NOTE: Read the entire instruction manual before starting the installation.

TABLE OF CONTENTS

	PAGE
SAFETY CONSIDERATIONS	1
INTRODUCTION	2
INSTALLATION	2
Airflow	2
TXV	2
CNPVP Models:	2
CNRVP Models:	2
Inspect Equipment	2
Select Installation Procedure	2
Installation of Furnace Coils	3
Connect Refrigerant Piping	5
Connect Refrigerant Liquid and Suction Lines	5
Refrigerant Metering Device	5
Condensate Drain Line Connection	5
Humidifier Application	6

SAFETY CONSIDERATIONS

Improper installation, adjustment, alteration, service, maintenance, or use can cause explosion, fire, electrical shock, or other conditions which may cause death, personal injury or property damage. Consult a qualified installer, service agency, or your distributor or branch for information or assistance. The qualified installer or agency must use factory-authorized kits or accessories when modifying this product. Refer to the individual instructions packaged with the kits or accessories when installing.

Follow all safety codes. Wear safety glasses, protective clothing, and work gloves. Use quenching cloth for brazing operations. Have fire extinguisher available. Read these instructions thoroughly and follow all warning or cautions included in literature and attached to the unit. Consult local building codes and the current editions of the National Electrical Code (NEC) NFPA 70.

In Canada, refer to the current editions of the Canadian Electrical Code CSA C22.1.

Recognize safety information. When you see this symbol  on the unit and in instructions or manuals, be alert to the potential for personal injury. Understand the signal words **DANGER**, **WARNING**, **CAUTION**, and **NOTE**. These words are used with the safety-alert symbol. **DANGER** identifies the most serious hazards which **will** result in severe personal injury or death. **WARNING** signifies hazards which **could** result in personal injury or death. **CAUTION** is used to identify unsafe practices which **may** result in minor personal injury or product and property

damage. **NOTE** is used to highlight suggestions which **will** result in enhanced installation, reliability, or operation.

IMPORTANT: Nitrogen can leak out through the hole that the needle pierced in the plugs. This does not indicate a leaking coil nor warrant return of the coil.

WARNING

ELECTRICAL SHOCK HAZARD

Failure to follow this warning could result in personal injury or death.

Before installing, modifying or servicing system, always turn off main power to system. There may be more than one disconnect switch. Lock out and tag switch with a suitable warning label.

CAUTION

PERSONAL INJURY HAZARD

Failure to follow this caution may result in personal injury.

This coil contains Nitrogen precharge of 15 PSIG. Release of this pressure through the center of the rubber plugs is required before removing the plugs.

CAUTION

ENVIRONMENTAL HAZARD

Failure to follow this caution may result in environmental pollution.

Remove and recycle all components or materials (i.e. oil, refrigerant, etc.) before unit final disposal.

CAUTION

CUT HAZARD

Failure to follow this caution may result in personal injury.

Sheet metal parts may have sharp edges or burrs. Use care and wear appropriate protective clothing and gloves when handling parts.

INTRODUCTION

Use this instruction manual to install indoor coils on upflow or downflow furnaces. Do not install coil in horizontal position. Models CNPVP/CNRVP are enclosed in a painted casing and both coils have factory-installed TXV's. CNPVP models are used with Puron® refrigerant (R-410A) systems and CNRVP models are used with R-22 systems.

NOTE: Models with tin-plated copper coils, "T" in the 11th position of the model number, are installed the same as standard copper coils.

INSTALLATION

These units can be installed in multiple configurations. Before installation, there are several performance requirements that must be considered because poor installation can negatively alter performance. This section will briefly discuss those factors.

Airflow

Airflow amount and distribution are vital to adequate system performance. Problems that can be experienced with incorrect airflow include:

- low system performance
- restricted TXV
- frosted coil
- poor humidity control
- water blow-off

When attaching the coil and building the plenum, pay special attention to the effect these details will have on airflow. After system start-up, check the cfm to insure that it is correct. (Generally, the cfm should be 350 to 400 cfm/ton during normal cooling operation.)

TXV

A thermal expansion valve is utilized in this coil design to optimize performance and comfort throughout the entire operating range of the system. Special attention needs to be taken to the TXV when installing the coil

- Do not overheat valve. Temperatures that exceed 212°F (100°C) can harm valve performance. Use a wet cloth or heat sink when brazing.
- Place liquid filter dryer near ID unit to reduce the risk of debris clogging the valve.
- Make sure TXV bulb is securely fastened and wrapped in the indentation on vapor line tube.

CNPVP Models:

These coils have a factory-installed hard-shutoff TXV designed only for use with R-410A refrigerant. Use only with outdoor units designed for R-410A.

CNRVP Models:

These coils have a factory-installed hard-shutoff TXV designed only for use with R-22 refrigerant. Use only with outdoor units designed for R-22.

NOTE: All TXV'S have preset superheat settings and are not field-adjustable.

Cabinet Sweating

If this unit is installed in a garage, attic, or other unconditioned space, special attention needs to be given to the potential of cabinet sweating. A 6-in (152 mm) wide piece of insulation should be wrapped around the coil casing and supply duct connection point.

Inspect Equipment

File claim with shipper if equipment is damaged.

Select Installation Procedure

⚠ CAUTION

PROPERTY DAMAGE HAZARD

Failure to follow this caution may result in property damage.

Installing coils rotated 90° from the front of the furnace, in upflow or downflow applications, may cause water blow-off or coil freeze-up due to the concentration of air on one slab of the coil or lack of air to a slab in the coil. It is recommended that on this type of application, a field-supplied adapter be placed between the coil and furnace to allow air to distribute properly between all slabs of the coil.

NOTE: Furnace coils are not approved to be used in fan coil or "draw-through" type applications.

To install cased coils in upflow applications, follow the instructions below, **Upflow Cased Coil Installation**.

To install cased coils in downflow applications, follow the instructions below, **Downflow Cased Coil Installation**.

See Table 1 for dimensions and overhang options. Refer to instructions for placement of coil casing on furnace.

Table 1 – CNPVP/CNRVP CASED COIL INFORMATION

MODEL NUMBER	TONS	FLUSH FIT TO FURNACE WIDTH IN. (mm)	COIL CONNECTION TUBE SIZE IN.		SHELF WIDTH (See Fig. 1, Dim. A) IN. (mm)	FITS NEXT SMALLER FURNACE		
			Liquid	Suction		Equal Overhang	Overhang with Transition	Offset Left
CN(P,R)VP1814A(C,T)A	1-1/2	14-3/16 (360)	3/8	5/8	12-7/8 (327)	-	-	-
CNPVP1917A(C,T)A	1-1/2	17-1/2 (445)	3/8	5/8	16-3/16 (411)	-	X	X
CN(P,R)VP2414A(C,T)A	2	14-3/16 (360)	3/8	5/8	12-7/8 (327)	-	-	-
CN(P,R)VP2417A(C,T)A	2	17-1/2 (445)	3/8	5/8	16-3/16 (411)	-	X	X
CN(P,R)VP3014A(C,T)A	2-1/2	14-3/16 (360)	3/8	3/4	12-7/8 (327)	-	-	-
CN(P,R)VP3017A(C,T)A	2-1/2	17-1/2 (445)	3/8	3/4	16-3/16 (411)	-	X	X
CNPVP3117A(C,T)A	2-1/2	17-1/2 (445)	3/8	3/4	16-3/16 (411)	-	X	X
CN(P,R)VP3617A(C,T)A	3	17-1/2 (445)	3/8	3/4	16-3/16 (411)	-	X	X
CN(P,R)VT3617A(C,T)A	3	17-1/2 (445)	3/8	3/4	16-3/16 (411)	X	-	-
CN(P,R)VP3621A(C,T)A	3	21 (533)	3/8	3/4	19-5/8 (498)	-	X	X
CNPVP3717A(C,T)A	3	17-1/2 (445)	3/8	3/4	16-3/16 (411)	X	-	-
CN(P,R)VP4217A(C,T)A	3-1/2	17-1/2 (445)	3/8	3/4	19-5/8 (498)	-	X	X
CN(P,R)VP4221A(C,T)A	3-1/2	21 (533)	3/8	7/8	19-5/8 (498)	-	X	X
CNPVP4324A(C,T)A	3-1/2	24-1/2 (622)	3/8	7/8	23-1/8 (587)	-	X	X
CN(P,R)VT4221A(C,T)A	3-1/2	21 (533)	3/8	7/8	19-5/8 (498)	X	-	-
CN(P,R)VP4821A(C,T)A	4	21 (533)	3/8	7/8	19-5/8 (498)	-	X	X
CN(P,R)VT4821A(C,T)A	4	21 (533)	3/8	7/8	19-5/8 (498)	X	-	-
CN(P,R)VP4824A(C,T)A	4	24-1/2 (622)	3/8	7/8	23-1/8 (587)	-	X	X
CN(P,R)VP6024A(C,T)A	5	24-1/2 (622)	3/8	7/8	23-1/8 (587)	-	X	X
CN(P,R)VT6024A(C,T)A	5	24-1/2 (622)	3/8	7/8	23-1/8 (587)	X	-	-
CNPVP6124A(C,T)A	5	24-1/2 (622)	3/8	7/8	23-1/8 (587)	-	X	-

CNPVP / CNRVP

NOTES:

For the 3rd digit position in the model number; P = Puron (R-410A) refrigerant and R=R-22 refrigerant

For the 5th digit position in the model number; P = painted cabinet, T = transition coil

For the 11th digit position in the model number; C = standard copper and T= tin plated copper

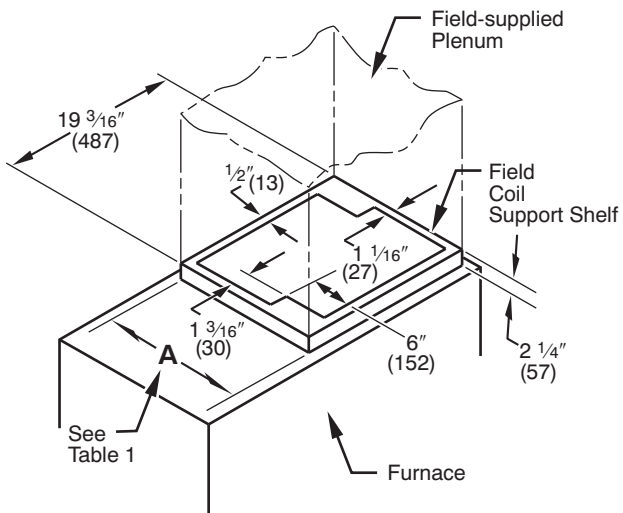

A08336

Fig. 1 - Correct Orientation of Coil Support on Furnace

Installation of Furnace Coils

Upflow Cased Coil Installation

NOTE: On upflow installations where the indoor coil is placed in an unconditioned space, a 6-in (152 mm) wide piece of insulation should be applied and wrapped around the outside of coil casing and supply duct contact point.

1. Set coil in place on upflow furnace discharge air opening. See Fig. 2.
2. When coil front width matches furnace front width, the coil can be placed directly on furnace.
3. Ensure coil is level for proper condensate drainage. Do not tip coil toward condensate drain. Coil enclosure need not be fastened or screwed to furnace.

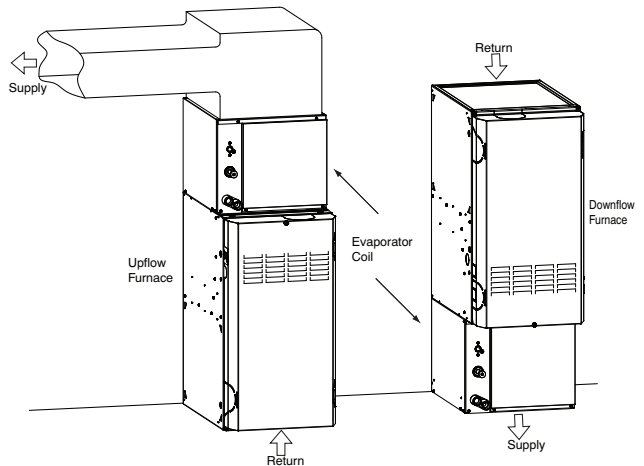

A05411

Fig. 2 - Typical Coil Installation

NOTE: When CNPVT/CNRVT (transition coils) are applied to same width furnace, remove block-off plates at casing base by removing 2 screws per plate from side of casing. See Fig. 3.

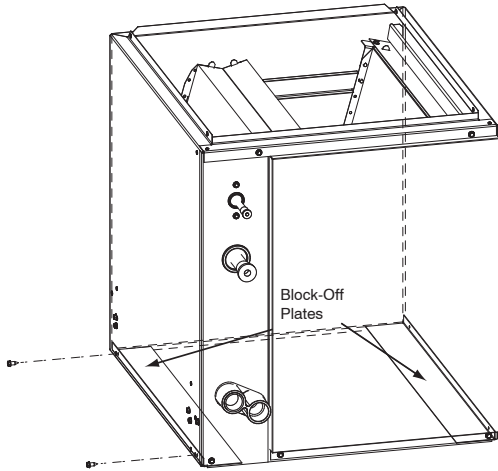
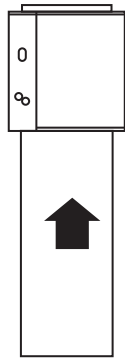

Fig. 3 - Block-Off Plate Removal

TRANSITION MODEL COILS APPLIED CENTERED OVER NARROW FURNACE

1. There is no transition required for this application.
2. Remove coil from packaging and place on top of furnace with 1 5/8-in (41 mm) overhang on both sides. See Fig. 4, Alternative A.
3. Continue with normal installation practices. See Connect Refrigerant Piping.



ALTERNATIVE A

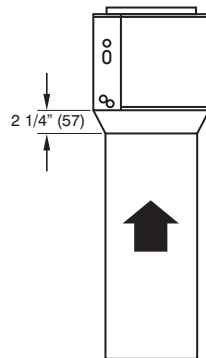

ALTERNATIVE B

MODELS: T036, T042, T048, AND T060 ONLY

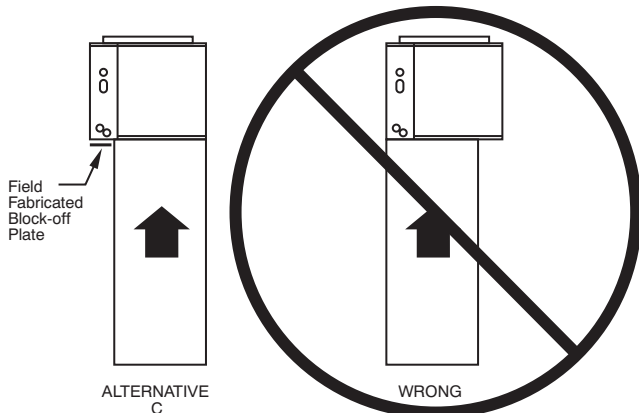

Fig. 4 - Alternative Coil Mounting Positions

STANDARD MODEL COIL APPLIED CENTERED OVER NARROW FURNACE REQUIRE A MINIMUM TRANSITION AS SPECIFIED IN FIG. 5.

1. Prepare transition, following recommended transition drawing. See Fig. 5.
2. Place transition on top of gas furnace. See Fig. 4, Alternative B. Secure with sheet metal screws. Place coil on top of transition. Make sure coil rests evenly on top of transition and gas furnace.
3. Secure coil to transition using sheet metal screws.
4. Continue with normal installation practices. See Connect Refrigerant Piping.

NOTE: If coil is not being installed in the standard orientation (front of coil matching front of furnace) then coil must be raised above furnace as specified in Fig. 5.

STANDARD MODEL COIL APPLIED DIRECTLY ON TOP AND OFFSET TO THE LEFT ON NARROW FURNACE

1. Notch support rail on underside of coil cabinet to provide clearances for gas furnace flange. This rail is not visible from front of coil. To locate position of notch, place coil directly on top of gas furnace with overhanging portion entirely on left side as in Fig. 4, Alternative C. Mark location of gas furnace flange on coil casing. Remove coil from top of furnace. Using tin snips, make a notch in rail large enough to allow clearance for gas flow furnace flange.
2. Place coil on top of gas furnace. Make sure coil is shifted completely to left side, and notch is sufficient so coil rests on top of furnace cabinet.
3. Prepare and install block-off plate. See Fig. 4, Alternative C. Using field-supplied sheet metal, cut a block-off plate to be attached to bottom left side of coil casing. This plate prevents air leakage from overhanging portion of coil. Attach plate using sheet metal screws.
4. Continue with normal installation practices. See Connect Refrigerant Piping.

Downflow Cased Coil Installation

1. Place N-coil on supply duct opening.
2. When coil width matches furnace width, furnace can be placed directly on the cased coil.

NOTE: In downflow installation with a 4-way multipoise furnace, break off perforated duct flanges on furnace. See Furnace Installation Instructions.

3. Coils that under-hang (narrower than furnace) must have a field-fabricated transition between furnace and N-coil casing as specified in Fig. 5.
4. Coils that overhang (wider than furnace) do not require a transition in downflow application. However, a field-supplied furnace shelf should be constructed to fit furnace to coil opening.
5. Place furnace on top of N-coil casing, or field-supplied furnace shelf.

A08337

CNPVP / CNRVP

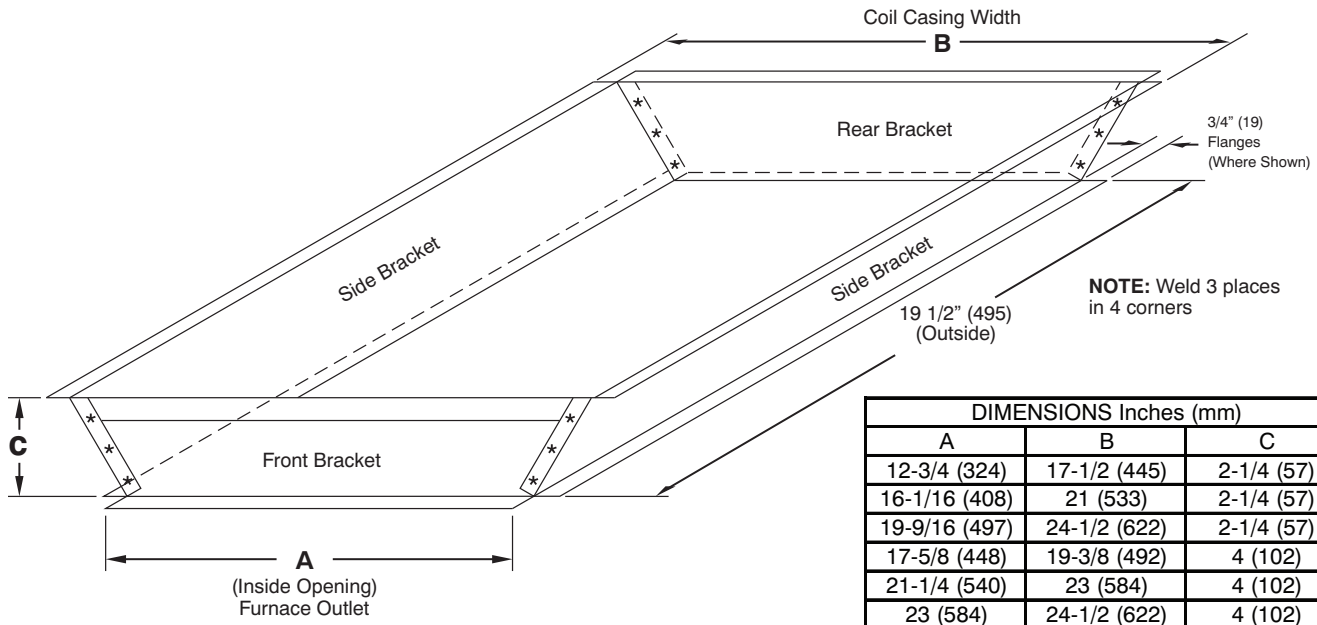

Fig. 5 - Recommended Transition

A09395

CNPVP / CNRVP

Connect Refrigerant Piping

Use accessory tubing package or field-supplied tubing of refrigerant grade. Suction tube must be insulated. Do not use damaged, dirty, or contaminated tubing because it may plug refrigerant flow-control device. ALWAYS evacuate the coil and field-supplied tubing before opening outdoor unit service valves.

Connect Refrigerant Liquid and Suction Lines

For matched and mismatched systems, use line sizes recommended in outdoor unit Installation Instructions.

The coil can be connected to outdoor units using accessory tubing packages or field-supplied tubing of refrigerant grade. Always evacuate tubing and reclaim refrigerant when making connections or flaring tubing. Leak check connections before insulating entire suction line.

Suction Line

Suction line is designed for field sweat connection. Line is plugged to keep out moisture and dirt. Remove these plugs only when ready to make connection.

See Table 1 for coil connection tube size.

⚠ CAUTION

UNIT DAMAGE HAZARD

Failure to follow this caution may result in product damage.

To avoid valve damage to the refrigerant control device while brazing, valves must be wrapped with a heat-sinking material such as a wet cloth.

1. Remove cabinet access door.
2. Remove rubber plugs from coil stubs using a pulling and twisting motion. Hold coil stubs steady to avoid bending or distorting.
3. Wrap TXV and nearby tubing with a heat sinking material such as a wet cloth.
4. Use 1/2 psig Nitrogen purge in the suction and out the liquid line.
5. Braze using a Sil-Fos or Phos-copper alloy. Do not use soft solder.

6. After brazing, allow joints to cool. Slide rubber grommets over joints. Position tubing at center of each grommet to ensure an air seal around the tube.
7. Always evacuate lines and reclaim refrigerant when making connections or flaring refrigerant lines. Leak check connections before insulating entire suction line.
8. If outdoor equipment will not be installed until a later date, braze liquid and suction lines closed outside. Add a Schraeder port test fitting to the suction line outside.

Refrigerant Metering Device

CNPVP Models:

These coils have a factory-installed hard shut-off TXV designed only for use with R-410A refrigerant. Use only with outdoor units designed for R-410A.

CNRVP Models:

These coils have a factory-installed hard shut-off TXV designed only for use with R-22 refrigerant. Use only with outdoor units designed for R-22.

NOTE: ALL TXV'S HAVE PRESET SUPERHEAT SETTINGS AND ARE NOT FIELD-ADJUSTABLE.

Condensate Drain Line Connection

The coil is designed to dispose of accumulated water through built-in condensate drain fittings. It is recommended that PVC fittings be used on the condensate pan. Do not over-tighten. Finger tighten plus 1-1/2 turns. Be sure to install plastic plug in unused condensate drain fitting.

NOTE: If unit is located in or above a living space where damage may result from condensate overflow, a field-supplied, external condensate pan should be installed under the entire unit, and a secondary condensate line (with appropriate trap) should be run from unit into pan. Any condensate in this external condensate pan should be drained to a noticeable place. As an alternative to using an external condensate pan, some localities may allow the running of a separate 3/4-in (19 mm) condensate line (with appropriate trap) to a place where condensate will be noticeable. The owner of the structure must be informed that when condensate flows from the secondary drain or external condensate pan, the unit requires servicing or water damage will occur. To further protect against water damage, install a float switch to shut the unit off if the water in the secondary pan gets too high.

Install traps in condensate lines as close to coil as possible. See Fig. 6. Make sure that outlet of each trap is below its connection to condensate pan to prevent condensate from overflowing drain pan. Prime all traps, test for leaks, and insulate traps and lines if located above a living area. Consult local codes for additional restrictions or precautions.

Humidifier Application

When installing a humidifier in a system which contains an N-coil, consideration must be given to location of coil slabs. See Fig. 7.

1. The humidifier should be mounted to the supply plenum or return duct whenever possible. If necessary, humidifiers can be mounted to the left side of coil casing. The right side of the coil casing must not be used to mount the humidifier.
2. Care must be taken to prevent damage of N-coil when attaching humidifier to coil casing or plenum.
3. Ensure that humidifier has adequate airflow.

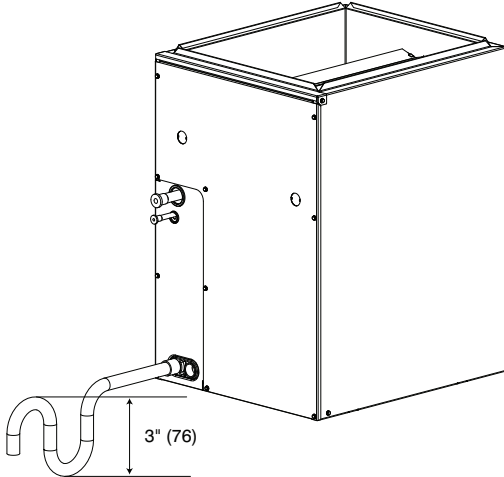

A08339

Fig. 6 - Condensate Trap

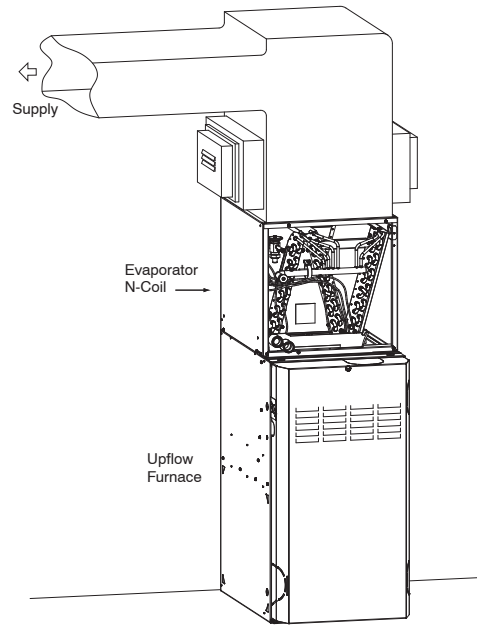

A05414

Fig. 7 - Installation of Humidifier in System with N-Coil