

## EFFICIENT 13 SEER AIR CONDITIONER

1½ THRU 5 TONS SPLIT SYSTEM

208 / 230 Volt, 1-phase, 60 Hz

### REFRIGERATION CIRCUIT

- Copeland® compressors on all models
- Filter-Drier supplied with every unit for field installation
- Copper tube / aluminum fin coil

### EASY TO INSTALL AND SERVICE

- Easy Access service valves on all models
- External high and low refrigerant service ports
- Only two screws to access control panel
- Factory charged with R-22 refrigerant

### BUILT TO LAST

- Baked-on powder coat finish over galvanized steel
- Post-painted (black) coil fins
- Coated, weather-resistant cabinet screws
- Coated inlet grille with 2" spacing standard, alternate models available with ¾" grille spacing for extra protection
- 5 year compressor, coil, and parts limited warranties



ARI Standard 210/240  
Unitary Air Conditioners

Rated in accordance with ARI Standard 210.  
Certification applies only when used with proper  
components as listed with ARI.



Model Number	Size (tons)	Nominal BTU/hr	Min. Circuit Ampacity	Max. Fuse or Breaker	Operating Dimensions height x width x depth (in)	Ship / Operating Weight (lbs)
N2A318AKB	1½	18,000	10.1	15	25 x 25¾ x 25¾	154 / 120
18GKB	same model with 3/8" spacing inlet grille					
N2A324AKB	2	24,000	13.8	20	25 x 25¾ x 25¾	156 / 120
24GKB	same model with 3/8" spacing inlet grille					
N2A330AKB	2½	30,000	18.7	30	28⅞ x 25¾ x 25¾	170 / 130
30GKB	same model with 3/8" spacing inlet grille					
N2A336AKB	3	36,000	19.1	30	25½ x 31⅜ x 31⅜	177 / 139
36GKB	same model with 3/8" spacing inlet grille					
N2A342AKA	3½	42,000	25.4	40	39⅞ x 31⅜ x 32⅝	217 / 189
42GKA	same model with 3/8" spacing inlet grille					
N2A348AKA	4	48,000	26.4	40	35¾ x 35 x 36⅞	246 / 212
48GKA	same model with 3/8" spacing inlet grille					
N2A360AKB	5	60,000	32.9	50	39⅞ x 35 x 35	265 / 222
60GKB	same model with 3/8" spacing inlet grille					

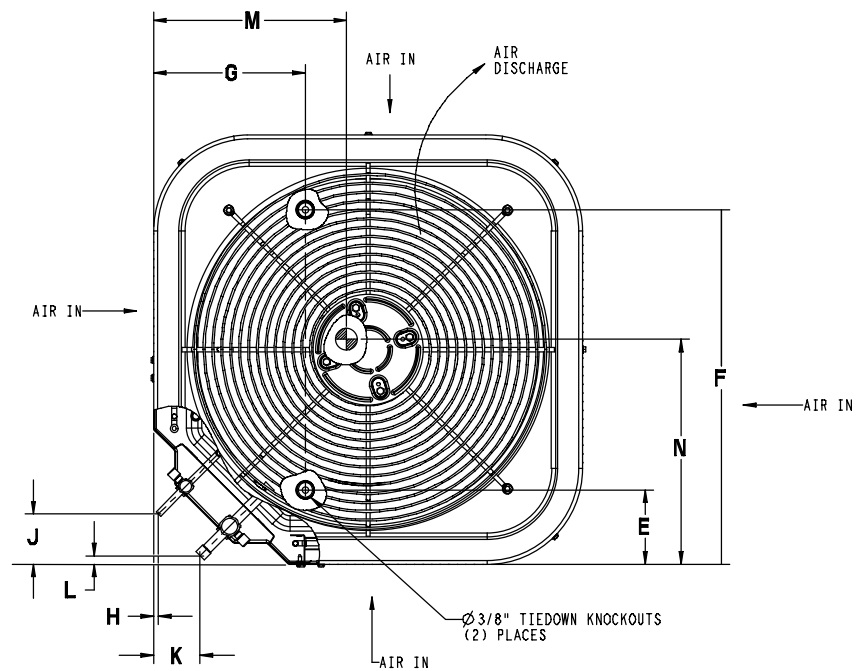
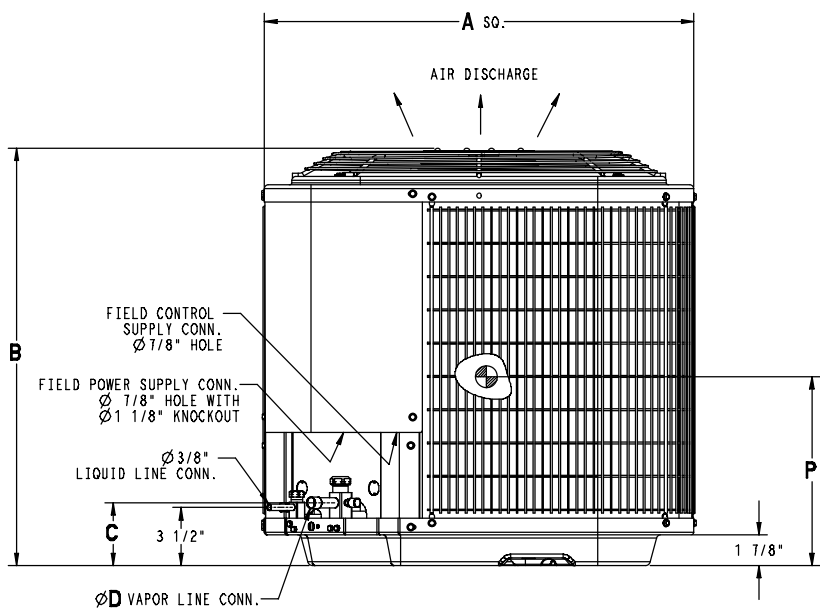

All Dimensions Inches

Model (* = A or G)	All Dimensions Inches														Minimum Mounting Pad Size	Crated Dimensions B(h) x A(w) x R(d)
	A	B	C	D	E	F	G	H	J	K	L	M	N	P		
N2A318*KB	25 3/4	25	3 3/4	3/4	4 7/16	21 1/4	9 1/8	5/16	3	2 13/16	1/2	13 1/2	14	10 1/2	26 x 26 1/2	32 9/16 x 30 1/16 x 26 7/8
N2A324*KB	25 3/4	25	3 3/4	3/4	4 7/16	21 1/4	9 1/8	5/16	3	2 13/16	1/2	11 1/2	12 1/2	10	26 x 26 1/2	32 9/16 x 30 1/16 x 26 7/8
N2A330*KB	25 3/4	28 7/16	3 3/4	3/4	4 7/16	21 1/4	9 1/8	5/16	3	2 13/16	1/2	15 1/2	12 1/2	14 1/4	26 x 26 1/2	32 9/16 x 30 1/16 x 26 7/8
N2A336*KB	31 1/16	25 1/2	3 7/8	7/8	6 9/16	24 11/16	9 1/8	5/16	3	2 13/16	1/2	16	15 1/4	13	31 1/2 x 32 1/2	32 9/16 x 35 1/2 x 32 3/8
N2A342*KB	31 1/16	39 1/8	3 7/8	7/8	6 9/16	24 11/16	9 1/8	5/16	3	2 15/16	5/8	16 7/8	16	18 3/4	31 1/2 x 32 1/2	42 3/4 x 35 1/2 x 33 3/8
N2A348*KB	35	35 3/4	3 7/8	7/8	6 9/16	28 7/16	9 1/8	5/16	3	2 15/16	5/8	18 1/4	18 1/2	17 1/2	35 x 35	39 3/8 x 39 5/16 x 36 1/8
N2A360*KB	35	39 1/8	3 7/8	7/8	6 9/16	28 7/16	9 1/8	5/16	3	2 15/16	5/8	17 1/4	16	15 1/2	35 x 35	42 3/4 x 39 5/16 x 36 1/8

PHYSICAL DATA							
Model Size	18	24	30	36	42	48	60
Nominal Cooling Capacity (BTU/hr)	18,000	24,000	30,000	36,000	42,000	48,000	60,000
Nominal SEER	13.0	13.0	13.0	13.0	13.0	13.0	13.0
Sound Rating (dBA)	76	76	76	78	79	80	80
PSC Fan Motor HP	1/12	1/10	1/5	1/5	1/4	1/4	1/4
Fan RPM (single speed)	1100	1100	1100	1100	1100	800	800
Fan CFM	1880	2200	2730	3170	3365	4050	4050
Coil Face Area (ft <sup>2</sup> )	9.85	9.85	11.49	12.93	21.56	22.63	25.15
Coil Rows - fins per inch	1 - 20	1 - 20	1 - 25	1 - 25	1 - 25	1 - 25	1 - 25
Liquid Line Connection Size (in.)	3/8	3/8	3/8	3/8	3/8	3/8	3/8
Vapor Line Connection Size (in.)	3/4	3/4	3/4	7/8	7/8	7/8	7/8
Recommended Line Set Liquid Tube Diameter (in.)	3/8	3/8	3/8	3/8	3/8	3/8	3/8
Recommended Line Set Vapor Tube Diameter (in.) *	3/4 *	3/4 *	3/4 *	7/8 *	7/8 *	7/8 *	1 1/8 *
* Recommended Vapor Tube Line size is for standard installations. These recommendations may not apply to "Long Line" installations. When the total equivalent line length exceeds 80 feet or there is more than 20 feet vertical separation between indoor and outdoor units, consult the Long Line Application Guideline document before purchasing/installing line sets.							
Factory Charge R-22 (lbs.)	3.9	4.5	4.9	5.4	7.15	7.73	9.2
Required Subcooling (°F)	10	11	10	7	11	10	10
Weight, shipping (lbs.)	154	156	170	177	217	246	265
Weight, operating (lbs.)	120	120	130	139	189	212	222

ELECTRICAL DATA (208/230-1-60, voltage range 197V - 253V)							
Model Size	18	24	30	36	42	48	60
Minimum Circuit Ampacity - <b>MCA</b> (amps)	10.1	13.8	18.7	19.1	25.4	26.4	32.9
Maximum OverCurrent Protective device - <b>MOCP</b> (amps)	15	20	30	30	40	40	50
Compressor <b>RLA</b> (Rated Load Amps)	7.7	10.4	14.1	14.4	19.2	20.2	25.3
<b>LRA</b> (Locked Rotor Amps)	40.3	54.0	68.0	77.0	104.0	137.0	141.0
Fan Motor <b>FLA</b> (Full Load Amps)	.5	.75	1.1	1.1	1.4	1.2	1.2

R-22 COOLING CAPACITY LOSS FOR VARIOUS LINE LENGTHS & TUBE DIAMETERS															
Model Size	Liquid Line (in.)	Acceptable Vapor Line Sizes (in.)	Cooling Capacity Loss (%) at Total Equivalent Line Length (ft.) Refer to Long Line Application Guideline to calculate equivalent length												
			Standard Application			Long Line Application (Requires Accessories) *									
			25'	50'	80'	81'	100'	125'	150'	175'	200'	225'	250'		
18	3/8	5/8	0.4	1.1	1.7	1.7	2.4	3.1	3.8	4.5	5.1	5.8	6.5		
		3/4	0.0	0.2	0.5	0.5	0.7	1.0	1.2	1.5	1.7	2.0	2.3		
24		5/8	0.7	1.9	3.0	3.0	4.2	5.3	6.5	7.6	8.8	9.9	11.1		
		3/4	0.0	0.5	0.9	0.9	1.3	1.8	2.2	2.6	3.0	3.5	3.9		
30		7/8	0.0	0.0	0.2	0.2	0.5	0.7	0.9	1.1	1.3	1.5	1.8		
		5/8	1.1	2.8	4.6	4.6	6.3	8.0	9.7	11.4	13.2	14.9	16.6		
		3/4	0.0	0.7	1.3	1.3	2.0	2.6	3.3	3.9	4.6	5.2	5.9		
36		7/8	0.0	0.0	0.4	0.4	0.7	1.0	1.3	1.7	2.0	2.3	2.6		
		3/4	0.4	1.3	2.2	2.2	3.1	4.0	4.9	5.8	6.7	7.6	8.5		
42		7/8	0.0	0.4	0.9	0.9	1.3	1.8	2.2	2.7	3.1	3.6	4.0		
		3/4	0.6	1.8	3.0	3.0	4.2	5.4	6.6	7.7	8.9	10.1	11.3		
		1 1/8	0.0	0.0	0.0	0.0	0.1	0.2	0.4	0.6	0.7	0.9	1.1		
48		7/8	0.0	0.6	1.2	1.2	1.8	2.4	3.0	3.6	4.2	4.8	5.4		
		3/4	0.7	2.2	3.8	3.8	5.3	6.8	8.3	9.8	11.4	12.9	14.4		
	1 1/8	0.0	0.0	0.0	0.0	0.0	0.3	0.5	0.7	0.9	1.1	1.3			
60	7/8	0.8	2.0	3.1	3.1	4.3	5.4	6.6	7.7	8.8	10.0	11.1			
	1 1/8	0.0	0.3	0.6	0.6	1.0	1.3	1.6	1.9	2.2	2.5	2.9			

\* Applications are considered “Long Line” if the total equivalent tubing length exceeds 80 feet or there is more than 20 foot vertical separation between indoor and outdoor units). These applications require additional accessories and system modifications for reliable system operation. Refer to the Long Line Application Guideline document for required piping and system modifications. Refer to Accessory Usage Guidelines below for required accessories.

Applications in this shaded area may have height restrictions that limit allowable total equivalent length when outdoor unit is below indoor unit. Refer to the Long Line Application Guideline document for instructions.

The maximum allowable total equivalent length is 250 feet.

ACCESSORY USAGE GUIDELINES		
Accessory	REQUIRED FOR LOW-AMBIENT APPLICATIONS (Below 55° F)	REQUIRED FOR LONG LINE APPLICATIONS* (Over 80 Ft.)
Crankcase Heater	<b>Yes</b>	<b>Yes</b>
Evaporator Freeze Thermostat	<b>Yes</b>	No
Winter Start Control	<b>Yes **</b>	No
Hard Start Kit (Capacitor & Relay)	<b>Yes</b>	<b>Yes</b>
Low Ambient Kit (Pressure Switch)	<b>Yes</b>	No
Support Feet, 4” tall	Recommended	No
Liquid Line Solenoid Valve	No	See Long Line Application Guideline

\* For Line Set lengths between 80 and 200 ft horizontal, or more than 20 ft indoor-outdoor vertical separation, refer to the Long Line Application Guideline document.

\*\* Can only be installed in conjunction with Low Pressure Switch.

<b>ACCESSORIES</b>		
<b>Part Number</b>	<b>Description</b>	<b>Used On Model Size</b>
NASA001CH	Crankcase Heater for Scroll Compressor (208/230 V)	42, 48, 60
NASA003CH	Crankcase Heater for Scroll Compressor (208/230 V)	18, 24, 30, 36
NASA001SC	Start Component - PTC Device	ALL
NASA001FS	Evaporator Freeze Thermostat	ALL
NASA201PS	Low Pressure Switch, AC, R-22	ALL
NASA201LS	Liquid Line Solenoid Valve, R-22	ALL
NASA001TD	Time Delay Relay, Indoor Blower	ALL
NASA001WS	Winter Start Control	ALL
NASA001AC	Anti-Cycle Timer (5 minute delay)	ALL
NASA202PS	High Pressure Switch, AC or HP, R-22	ALL
NASA003SC	Hard Start Kit (Capacitor & Relay)	18, 24, 36, 42, 48, 60
NASA005SC	Hard Start Kit (Capacitor & Relay)	30
NASA201LA	Low Ambient Kit (Pressure Switch), R-22	ALL
NASA001SF	Support Feet, 4" tall	ALL
NASA001SJ	Sound Jacket, Compressor	18, 24, 30, 36, 42, 48
NASA003SJ	Sound Jacket, Compressor	60
AMF153TKB	TXV Kit, R-22 (converts R-22 piston coils to R-22 TXV)	18, 24, 30, 36
AMF355TKB	TXV Kit, R-22 (converts R-22 piston coils to R-22 TXV)	42, 48, 60

**COOLING PERFORMANCE FOR COMBINATION RATINGS**  
**Indoor Models**

Outdoor Model	Current Indoor Model († tested combo)	Furnace Model	Factory Installed	Cooling (95 ° F)			SEER				
				BTU/hr	S/T	EER	factory	w/ field TDR	w/ field R-22 TXV	w/ field R-22 TXV + TDR	
N2A318AKB N2A318GKB	‡EB*2X18B**	†	TXV	17,100	0.75	11.20		13.00			
	^EB*2X18B**	*8MPV050	TDR&TXV	17,400	0.75	12.00	14.00				
	^EB*2X18B**	MV08B15**B*	TDR&TXV	17,100	0.75	12.00	14.00				
	EB*2X24B**	†	TXV	17,500	0.75	11.20		13.00			
	^EB*2X24B**	*8MPV050	TDR&TXV	18,000	0.75	12.00	14.00				
	^EB*2X24B**	MV08B15**B*	TDR&TXV	17,500	0.75	12.00	14.00				
	EB*2X24F**	†	TXV	17,500	0.75	11.20		13.00			
	ED*2X18B**	†	TXV	17,100	0.75	11.20		13.00			
	^ED*2X18B**	*8MPV050	TDR&TXV	17,400	0.75	12.00	14.00				
	^ED*2X18B**	MV08B15**B*	TDR&TXV	17,100	0.75	12.00	14.00				
	ED*2X24B**	†	TXV	17,500	0.75	11.20		13.00			
	^ED*2X24B**	*8MPV050	TDR&TXV	18,000	0.75	12.00	14.00				
	^ED*2X24B**	MV08B15**B*	TDR&TXV	17,500	0.75	12.00	14.00				
	ED*2X24F**	†	TXV	17,500	0.75	11.20		13.00			
	EMA2X24D**	†	TXV	17,500	0.75	11.20		13.00			
	EHD2X24A**	†	TXV	17,500	0.75	11.20		13.00			
	^EHD2X24A**	*8MPV050	TDR&TXV	18,000	0.75	12.00	14.00				
	^EHD2X24A**	*9MPV050	TDR&TXV	18,000	0.75	12.00	14.00				
	^EHD2X24A**	*9MPV075	TDR&TXV	18,000	0.75	12.00	14.00				
	^EHD2X24A**	MV08B15**B*	TDR&TXV	17,700	0.75	12.00	14.00				
	FS(M,U)2X18****	†	TDR&TXV	17,300	0.75	11.20	13.00				
	FS(M,U)2X24****	†	TDR&TXV	16,800	0.75	11.20	13.00				
	^FEM2X18****	†	TDR&TXV	17,600	0.75	12.00	14.00				
	^FEM2X24****	†	TDR&TXV	17,700	0.75	12.00	14.00				
	^FVM2X24****	†	TDR&TXV	17,000	0.75	12.00	14.00				
	FSA2X18****	†	TDR&TXV	16,800	0.75	11.20	13.00				
	FSA2X24****	†	TDR&TXV	17,400	0.75	11.20	13.00				
	N2A324AKB N2A324GKB	‡EB*2X24B**	†	TXV	22,800	0.77	11.20		13.00		
		EB*2X24B**	*8MPV050	TDR&TXV	23,000	0.77	11.70	13.50			
		^EB*2X24B**	MV08B15**B*	TDR&TXV	22,800	0.77	12.00	14.00			
EB*2X24F**		†	TXV	22,800	0.77	11.20		13.00			
^EB*2X24F**		*8MPV075	TDR&TXV	23,200	0.77	12.00	14.00				
^EB*2X24F**		*9MPV050	TDR&TXV	22,800	0.77	12.00	14.00				
^EB*2X24F**		*9MPV075	TDR&TXV	23,000	0.77	12.00	14.00				
^EB*2X24F**		MV12F19**B*	TDR&TXV	22,800	0.77	12.00	14.00				
EB*2X30B**		†	TXV	23,000	0.77	11.20		13.00			
EB*2X30B**		*8MPV050	TDR&TXV	23,200	0.77	11.70	13.50				
^EB*2X30B**		MV08B15**B*	TDR&TXV	23,000	0.77	12.00	14.00				
EB*2X30F**		†	TXV	22,800	0.77	11.20		13.00			
^EB*2X30F**		*8MPV075	TDR&TXV	23,400	0.77	12.00	14.00				
^EB*2X30F**		*9MPV050	TDR&TXV	23,000	0.77	12.00	14.00				
^EB*2X30F**		*9MPV075	TDR&TXV	23,200	0.77	12.00	14.00				
^EB*2X30F**		MV12F19**B*	TDR&TXV	23,000	0.77	12.00	14.00				
ED*2X24B**		†	TXV	22,800	0.77	11.20		13.00			
ED*2X24B**		*8MPV050	TDR&TXV	23,000	0.77	11.70	13.50				
^ED*2X24B**		MV08B15**B*	TDR&TXV	22,800	0.77	12.00	14.00				
ED*2X24F**		†	TXV	22,800	0.77	11.20		13.00			
^ED*2X24F**		*8MPV075	TDR&TXV	23,200	0.77	12.00	14.00				
^ED*2X24F**		*9MPV050	TDR&TXV	22,800	0.77	12.00	14.00				
^ED*2X24F**		*9MPV075	TDR&TXV	23,000	0.77	12.00	14.00				
^ED*2X24F**		MV12F19**B*	TDR&TXV	22,800	0.77	12.00	14.00				
ED*2X30B**		†	TXV	23,000	0.77	11.20		13.00			
ED*2X30B**		*8MPV050	TDR&TXV	23,200	0.77	11.70	13.50				
^ED*2X30B**		MV08B15**B*	TDR&TXV	23,000	0.77	12.00	14.00				
ED*2X30F**		†	TXV	23,000	0.77	11.20		13.00			
^ED*2X30F**		*8MPV075	TDR&TXV	23,400	0.77	12.00	14.00				
^ED*2X30F**		*9MPV050	TDR&TXV	23,000	0.77	12.00	14.00				

^ Indicates ENERGY STAR compliance for combinations with both: SEER 14.0 or higher and EER 11.5 or higher.

† For coils not listed with a matching furnace or blower, coil rating applies with any indoor blower device.

- continued on next page -

COOLING PERFORMANCE FOR COMBINATION RATINGS (continued)										
Indoor Models										
Outdoor Model	Current Indoor Model († tested combo)	Furnace Model	Factory Installed	Cooling (95 °F)			SEER			
				BTU/hr	S/T	EER	factory	w/ field TDR	w/ field R-22 TXV	w/ field R-22 TXV + TDR
N2A324AKB N2A324GKB (continued)	^ED*2X30F**	*9MPV075	TDR&TXV	23,200	0.77	12.00	14.00			
	^ED*2X30F**	MV12F19**B*	TDR&TXV	23,000	0.77	12.00	14.00			
	EMA2X24D**	†	TXV	22,800	0.77	11.20		13.00		
	EHD2X24A**	†	TXV	22,800	0.77	11.20		13.00		
	EHD2X24A**	*8MPV050	TDR&TXV	23,000	0.77	11.70	13.50			
	^EHD2X24A**	*8MPV075	TDR&TXV	23,000	0.77	12.00	14.00			
	^EHD2X24A**	*8MPV100	TDR&TXV	23,200	0.77	12.00	14.00			
	^EHD2X24A**	*8MPV125	TDR&TXV	23,200	0.77	12.00	14.00			
	^EHD2X24A**	*9MPV050	TDR&TXV	23,000	0.77	12.00	14.00			
	^EHD2X24A**	*9MPV075	TDR&TXV	23,000	0.77	12.00	14.00			
	^EHD2X24A**	*9MPV100	TDR&TXV	23,000	0.77	12.00	14.00			
	^EHD2X24A**	*9MPV125	TDR&TXV	23,200	0.77	12.00	14.00			
	^EHD2X24A**	MV08B15**B*	TDR&TXV	23,000	0.77	12.00	14.00			
	^EHD2X24A**	MV12F19**B*	TDR&TXV	23,200	0.77	12.00	14.00			
	EHD2X30A**	†	TXV	23,000	0.77	11.20		13.00		
	EHD2X30A**	*8MPV050	TDR&TXV	23,400	0.77	11.70	13.50			
	^EHD2X30A**	*8MPV075	TDR&TXV	23,400	0.77	12.00	14.00			
	^EHD2X30A**	*8MPV100	TDR&TXV	23,600	0.77	12.00	14.00			
	^EHD2X30A**	*8MPV125	TDR&TXV	23,600	0.77	12.00	14.00			
	^EHD2X30A**	*9MPV050	TDR&TXV	23,000	0.77	12.00	14.00			
	^EHD2X30A**	*9MPV075	TDR&TXV	23,200	0.77	12.00	14.00			
	^EHD2X30A**	*9MPV100	TDR&TXV	23,400	0.77	12.00	14.00			
	^EHD2X30A**	*9MPV125	TDR&TXV	23,600	0.77	12.00	14.00			
	^EHD2X30A**	MV08B15**B*	TDR&TXV	23,200	0.77	12.00	14.00			
	^EHD2X30A**	MV12F19**B*	TDR&TXV	23,200	0.77	12.00	14.00			
	FS(M,U)2X24****	†	TDR&TXV	23,000	0.77	11.20	13.00			
	FS(M,U)2X30****	†	TDR&TXV	22,800	0.77	11.20	13.00			
	^FEM2X24****	†	TDR&TXV	23,000	0.77	12.00	14.00			
	^FEM2X30****	†	TDR&TXV	23,200	0.77	12.00	14.00			
	^FVM2X24****	†	TDR&TXV	23,200	0.77	12.00	14.00			
	^FVM2X36****	†	TDR&TXV	23,000	0.77	12.00	14.00			
	FSA2X24****	†	TDR&TXV	22,400	0.77	11.20	13.00			
	FSA2X30****	†	TDR&TXV	22,600	0.77	11.20	13.00			
N2A330AKB N2A330GKB	‡EB*2X30B**	†	TXV	27,800	0.76	11.20		13.00		
	EB*2X30B**	*8MPV050	TDR&TXV	27,600	0.76	11.50	13.20			
	^EB*2X30B**	MV08B15**B*	TDR&TXV	27,800	0.76	12.00	14.00			
	EB*2X30F**	†	TXV	27,800	0.76	11.20		13.00		
	^EB*2X30F**	*8MPV075	TDR&TXV	28,000	0.76	12.00	14.00			
	EB*2X30F**	*9MPV050	TDR&TXV	27,600	0.76	11.70	13.50			
	EB*2X30F**	*9MPV075	TDR&TXV	27,600	0.76	11.70	13.50			
	^EB*2X30F**	MV12F19**B*	TDR&TXV	27,600	0.76	12.00	14.00			
	EB*2X36B**	†	TXV	27,800	0.76	11.20		13.00		
	EB*2X36B**	*8MPV050	TDR&TXV	27,800	0.76	11.50	13.50			
	^EB*2X36B**	MV08B15**B*	TDR&TXV	27,800	0.76	12.00	14.00			
	EB*2X36F**	†	TXV	28,000	0.76	11.20		13.00		
	^EB*2X36F**	*8MPV075	TDR&TXV	28,000	0.76	12.00	14.00			
	EB*2X36F**	*9MPV050	TDR&TXV	27,800	0.76	11.70	13.50			
	EB*2X36F**	*9MPV075	TDR&TXV	27,800	0.76	11.70	13.50			
	^EB*2X36F**	MV12F19**B*	TDR&TXV	28,000	0.76	12.00	14.00			
	EB*2X36J**	†	TXV	27,800	0.76	11.20		13.00		
	^EB*2X36J**	*8MPV100	TDR&TXV	28,400	0.76	12.00	14.00			
	^EB*2X36J**	*8MPV125	TDR&TXV	28,400	0.76	12.00	14.00			
	^EB*2X36J**	*9MPV100	TDR&TXV	28,200	0.76	12.00	14.00			
	ED*2X30B**	†	TXV	27,800	0.76	11.20		13.00		
ED*2X30B**	*8MPV050	TDR&TXV	27,600	0.76	11.50	13.20				
^ED*2X30B**	MV08B15**B*	TDR&TXV	27,800	0.76	12.00	14.00				
ED*2X30F**	†	TXV	27,800	0.76	11.20		13.00			

^ Indicates ENERGY STAR compliance for combinations with both: SEER 14.0 or higher and EER 11.5 or higher.

† For coils not listed with a matching furnace or blower, coil rating applies with any indoor blower device.

- continued on next page -

COOLING PERFORMANCE FOR COMBINATION RATINGS (continued)										
Indoor Models										
Outdoor Model	Current Indoor Model (‡ tested combo)	Furnace Model	Factory Installed	Cooling (95 ° F)			SEER			
				BTU/hr	S/T	EER	factory	w/ field TDR	w/ field R-22 TXV	w/ field R-22 TXV + TDR
N2A330AKB N2A330GKB (continued)	^ED*2X30F**	*8MPV075	TDR&TXV	28,000	0.76	12.00	14.00			
	ED*2X30F**	*9MPV050	TDR&TXV	27,600	0.76	11.70	13.50			
	ED*2X30F**	*9MPV075	TDR&TXV	27,600	0.76	11.70	13.50			
	^ED*2X30F**	MV12F19**B*	TDR&TXV	27,800	0.76	12.00	14.00			
	ED*2X36B**	†	TXV	27,800	0.76	11.20		13.00		
	ED*2X36B**	*8MPV050	TDR&TXV	27,800	0.76	11.50	13.50			
	^ED*2X36B**	MV08B15**B*	TDR&TXV	27,800	0.76	12.00	14.00			
	ED*2X36F**	†	TXV	28,000	0.76	11.20		13.00		
	^ED*2X36F**	*8MPV075	TDR&TXV	28,000	0.76	12.00	14.00			
	ED*2X36F**	*9MPV050	TDR&TXV	27,800	0.76	11.70	13.50			
	ED*2X36F**	*9MPV075	TDR&TXV	27,800	0.76	11.70	13.50			
	^ED*2X36F**	MV12F19**B*	TDR&TXV	28,000	0.76	12.00	14.00			
	ED*2X36J**	†	TXV	27,800	0.76	11.20		13.00		
	^ED*2X36J**	*8MPV100	TDR&TXV	28,400	0.76	12.00	14.00			
	^ED*2X36J**	*8MPV125	TDR&TXV	28,400	0.76	12.00	14.00			
	^ED*2X36J**	*9MPV100	TDR&TXV	28,200	0.76	12.00	14.00			
	EMA2X36D**	†	TXV	28,000	0.76	11.20		13.00		
	EHD2X30A**	†	TXV	27,800	0.76	11.20		13.00		
	EHD2X30A**	*8MPV050	TDR&TXV	27,600	0.76	11.50	13.20			
	EHD2X30A**	*8MPV075	TDR&TXV	27,800	0.76	11.70	13.50			
	EHD2X30A**	*8MPV100	TDR&TXV	27,800	0.76	11.70	13.50			
	^EHD2X30A**	*8MPV125	TDR&TXV	27,800	0.76	12.00	14.00			
	EHD2X30A**	*9MPV050	TDR&TXV	27,400	0.76	11.70	13.50			
	EHD2X30A**	*9MPV075	TDR&TXV	27,400	0.76	11.70	13.50			
	^EHD2X30A**	*9MPV100	TDR&TXV	27,600	0.76	12.00	14.00			
	^EHD2X30A**	*9MPV125	TDR&TXV	27,600	0.76	12.00	14.00			
	^EHD2X30A**	MV08B15**B*	TDR&TXV	27,800	0.76	12.00	14.00			
	^EHD2X30A**	MV12F19**B*	TDR&TXV	27,800	0.76	12.00	14.00			
	EHD2X36A**	†	TXV	28,000	0.76	11.20		13.00		
	EHD2X36A**	*8MPV050	TDR&TXV	28,000	0.76	11.70	13.50			
	^EHD2X36A**	*8MPV075	TDR&TXV	28,200	0.76	12.00	14.00			
	^EHD2X36A**	*8MPV100	TDR&TXV	28,200	0.76	12.00	14.00			
	^EHD2X36A**	*8MPV125	TDR&TXV	28,200	0.76	12.00	14.00			
	^EHD2X36A**	*9MPV050	TDR&TXV	27,800	0.76	12.00	14.00			
	^EHD2X36A**	*9MPV075	TDR&TXV	27,800	0.76	12.00	14.00			
	^EHD2X36A**	*9MPV100	TDR&TXV	28,200	0.76	12.00	14.00			
	^EHD2X36A**	*9MPV125	TDR&TXV	28,200	0.76	12.00	14.00			
	^EHD2X36A**	MV08B15**B*	TDR&TXV	28,000	0.76	12.00	14.00			
	^EHD2X36A**	MV12F19**B*	TDR&TXV	28,000	0.76	12.00	14.00			
	FS(M,U)2X30****	†	TDR&TXV	27,600	0.76	11.20	13.00			
	FSU2X36****	†	TDR&TXV	27,600	0.76	11.00	13.00			
	^FEM2X30****	†	TDR&TXV	28,000	0.76	12.00	14.00			
	FEM2X35****	†	TDR&TXV	28,200	0.76	11.70	13.50			
	FSM2X36****	†	TDR&TXV	28,400	0.76	11.20	13.00			
	^FEM2X36****	†	TDR&TXV	28,600	0.76	12.00	14.00			
	^FVM2X24****	†	TDR&TXV	28,000	0.76	12.00	14.00			
	^FVM2X36****	†	TDR&TXV	28,000	0.76	12.00	14.00			
^FVM2X48****	†	TDR&TXV	28,800	0.76	12.00	14.00				
FSA2X30****	†	TDR&TXV	27,400	0.76	11.20	13.00				
FSA2X36****	†	TDR&TXV	27,800	0.76	11.20	13.00				
N2A336AKB N2A336GKB	‡EB*2X36F**	†	TXV	33,800	0.75	11.20		13.00		
	EB*2X36B**	†	TXV	33,600	0.75	11.20		13.00		
	^EB*2X36B**	MV08B15**B*	TDR&TXV	33,800	0.75	12.00	14.00			
	EB*2X36F**	*8MPV075	TDR&TXV	33,800	0.75	11.70	13.50			
	EB*2X36F**	*9MPV050	TDR&TXV	33,400	0.75	11.20	13.00			
EB*2X36F**	*9MPV075	TDR&TXV	33,600	0.75	11.50	13.20				
^EB*2X36F**	MV12F19**B*	TDR&TXV	34,000	0.75	12.00	14.00				

^ Indicates ENERGY STAR compliance for combinations with both: SEER 14.0 or higher and EER 11.5 or higher.

† For coils not listed with a matching furnace or blower, coil rating applies with any indoor blower device.

- continued on next page -



COOLING PERFORMANCE FOR COMBINATION RATINGS (continued)										
Indoor Models										
Outdoor Model	Current Indoor Model († tested combo)	Furnace Model	Factory Installed	Cooling (95 °F)			SEER			
				BTU/hr	S/T	EER	factory	w/ field TDR	w/ field R-22 TXV	w/ field R-22 TXV + TDR
N2A336AKB N2A336GKB (continued)	EB*2X36J**	†	TXV	33,800	0.75	11.20		13.00		
	^EB*2X36J**	*8MPV100	TDR&TXV	34,400	0.75	12.00	14.00			
	^EB*2X36J**	*8MPV125	TDR&TXV	34,400	0.75	12.00	14.00			
	EB*2X36J**	*9MPV100	TDR&TXV	34,200	0.75	11.70	13.50			
	^EB*2X36J**	MV16J22**B*	TDR&TXV	34,000	0.75	12.00	14.00			
	EB*2X42F**	†	TXV	34,000	0.75	11.20		13.00		
	EB*2X42F**	*8MPV075	TDR&TXV	34,000	0.75	11.70	13.50			
	EB*2X42F**	*9MPV050	TDR&TXV	33,800	0.75	11.50	13.20			
	EB*2X42F**	*9MPV075	TDR&TXV	33,800	0.75	11.70	13.50			
	^EB*2X42F**	MV12F19**B*	TDR&TXV	33,800	0.75	12.00	14.00			
	EB*2X42J**	†	TXV	34,200	0.75	11.20		13.00		
	^EB*2X42J**	*8MPV100	TDR&TXV	34,600	0.75	12.00	14.00			
	^EB*2X42J**	*8MPV125	TDR&TXV	34,600	0.75	12.00	14.00			
	EB*2X42J**	*9MPV100	TDR&TXV	34,600	0.75	11.70	13.50			
	^EB*2X42J**	MV16J22**B*	TDR&TXV	34,200	0.75	12.00	14.00			
	EB*2X42L**	†	TXV	34,200	0.75	11.20		13.00		
	^EB*2X42L**	*9MPV125	TDR&TXV	34,600	0.75	12.00	14.00			
	^EB*2X42L**	MV20L24**B*	TDR&TXV	34,200	0.75	12.00	14.00			
	ED*2X36B**	†	TXV	33,600	0.75	11.20		13.00		
	^ED*2X36B**	MV08B15**B*	TDR&TXV	33,800	0.75	12.00	14.00			
	ED*2X36F**	†	TXV	33,800	0.75	11.20		13.00		
	ED*2X36F**	*8MPV075	TDR&TXV	33,800	0.75	11.70	13.50			
	ED*2X36F**	*9MPV050	TDR&TXV	33,400	0.75	11.20	13.00			
	ED*2X36F**	*9MPV075	TDR&TXV	33,600	0.75	11.50	13.20			
	^ED*2X36F**	MV12F19**B*	TDR&TXV	34,000	0.75	12.00	14.00			
	ED*2X36J**	†	TXV	33,800	0.75	11.20		13.00		
	^ED*2X36J**	*8MPV100	TDR&TXV	34,400	0.75	12.00	14.00			
	^ED*2X36J**	*8MPV125	TDR&TXV	34,400	0.75	12.00	14.00			
	ED*2X36J**	*9MPV100	TDR&TXV	34,200	0.75	11.70	13.50			
	^ED*2X36J**	MV16J22**B*	TDR&TXV	34,000	0.75	12.00	14.00			
	ED*2X42F**	†	TXV	34,200	0.75	11.20		13.00		
	ED*2X42F**	*8MPV075	TDR&TXV	34,200	0.75	11.70	13.50			
	ED*2X42F**	*9MPV050	TDR&TXV	33,800	0.75	11.50	13.20			
	ED*2X42F**	*9MPV075	TDR&TXV	33,800	0.75	11.70	13.50			
	^ED*2X42F**	MV12F19**B*	TDR&TXV	34,200	0.75	12.00	14.00			
	ED*2X42J**	†	TXV	34,200	0.75	11.20		13.00		
	^ED*2X42J**	*8MPV100	TDR&TXV	34,600	0.75	12.00	14.00			
	^ED*2X42J**	*8MPV125	TDR&TXV	34,600	0.75	12.00	14.00			
	ED*2X42J**	*9MPV100	TDR&TXV	34,600	0.75	11.70	13.50			
	^ED*2X42J**	MV16J22**B*	TDR&TXV	34,200	0.75	12.00	14.00			
	ED*2X42L**	†	TXV	34,200	0.75	11.20		13.00		
	^ED*2X42L**	*9MPV125	TDR&TXV	34,600	0.75	12.00	14.00			
	^ED*2X42L**	MV20L24**B*	TDR&TXV	34,200	0.75	12.00	14.00			
	EMA2X36D**	†	TXV	33,800	0.75	11.20		13.00		
	EHD2X36A**	†	TXV	33,800	0.75	11.20		13.00		
EHD2X36A**	*8MPV050	TDR&TXV	33,400	0.75	11.50	13.20				
^EHD2X36A**	*8MPV075	TDR&TXV	34,000	0.75	12.00	14.00				
^EHD2X36A**	*8MPV100	TDR&TXV	34,200	0.75	12.00	14.00				
^EHD2X36A**	*8MPV125	TDR&TXV	34,000	0.75	12.00	14.00				
EHD2X36A**	*9MPV050	TDR&TXV	33,400	0.75	11.70	13.50				
EHD2X36A**	*9MPV075	TDR&TXV	33,400	0.75	11.70	13.50				
EHD2X36A**	*9MPV100	TDR&TXV	34,000	0.75	11.70	13.50				
^EHD2X36A**	*9MPV125	TDR&TXV	34,000	0.75	12.00	14.00				
^EHD2X36A**	MV08B15**B*	TDR&TXV	33,600	0.75	12.00	14.00				
^EHD2X36A**	MV12F19**B*	TDR&TXV	33,800	0.75	12.00	14.00				
^EHD2X36A**	MV16J22**B*	TDR&TXV	33,800	0.75	12.00	14.00				
^EHD2X36A**	MV20L24**B*	TDR&TXV	33,800	0.75	12.00	14.00				

^ Indicates ENERGY STAR compliance for combinations with both: SEER 14.0 or higher and EER 11.5 or higher.

† For coils not listed with a matching furnace or blower, coil rating applies with any indoor blower device.

- continued on next page -

COOLING PERFORMANCE FOR COMBINATION RATINGS (continued)											
Indoor Models											
Outdoor Model	Current Indoor Model (‡ tested combo)	Furnace Model	Factory Installed	Cooling (95 ° F)			SEER				
				BTU/hr	S/T	EER	factory	w/ field TDR	w/ field R-22 TXV	w/ field R-22 TXV + TDR	
N2A336AKB N2A336GKB (continued)	EHD2X42A**	†	TXV	34,200	0.75	11.20		13.00			
	EHD2X42A**	*8MPV050	TDR&TXV	33,600	0.75	11.70	13.50				
	^EHD2X42A**	*8MPV075	TDR&TXV	34,200	0.75	11.70	14.00				
	^EHD2X42A**	*8MPV100	TDR&TXV	34,600	0.75	12.00	14.00				
	^EHD2X42A**	*8MPV125	TDR&TXV	34,600	0.75	12.00	14.00				
	EHD2X42A**	*9MPV050	TDR&TXV	33,800	0.75	11.70	13.50				
	EHD2X42A**	*9MPV075	TDR&TXV	34,000	0.75	11.70	13.50				
	EHD2X42A**	*9MPV100	TDR&TXV	34,400	0.75	11.70	13.50				
	^EHD2X42A**	*9MPV125	TDR&TXV	34,600	0.75	12.00	14.00				
	^EHD2X42A**	MV08B15**B*	TDR&TXV	34,200	0.75	12.00	14.00				
	^EHD2X42A**	MV12F19**B*	TDR&TXV	34,200	0.75	12.00	14.00				
	^EHD2X42A**	MV16J22**B*	TDR&TXV	34,200	0.75	12.00	14.00				
	^EHD2X42A**	MV20L24**B*	TDR&TXV	34,200	0.75	12.00	14.00				
	FSU2X36****	†	TDR&TXV	34,000	0.75	11.00	13.00				
	FS(M,U)2X42****	†	TDR&TXV	34,400	0.75	11.20	13.00				
	FEM2X35****	†	TDR&TXV	34,600	0.75	11.70	13.50				
	FSM2X36****	†	TDR&TXV	34,400	0.75	11.50	13.20				
	^FEM2X36****	†	TDR&TXV	35,200	0.75	12.00	14.00				
	^FEM2X42****	†	TDR&TXV	35,200	0.75	12.00	14.00				
	FVM2X24****	†	TDR&TXV	33,800	0.75	11.70	13.50				
	^FVM2X36****	†	TDR&TXV	34,200	0.75	12.00	14.00				
	^FVM2X48****	†	TDR&TXV	35,400	0.75	12.00	14.00				
	^FVM2X60****	†	TDR&TXV	35,600	0.75	12.00	14.00				
	FSA2X36****	†	TDR&TXV	33,800	0.75	11.20	13.00				
	N2A342AKA N2A342GKA	‡EB*2X42J**	†	TXV	40,500	0.77	11.00		13.00		
		EB*2X42J**	*8MPV100	TDR&TXV	40,500	0.77	11.20	13.50			
		EB*2X42J**	*8MPV125	TDR&TXV	40,500	0.77	11.20	13.50			
		EB*2X42J**	*9MPV100	TDR&TXV	40,500	0.77	11.00	13.20			
		^EB*2X42J**	MV16J22****	TDR&TXV	40,500	0.77	11.50	14.00			
		EB*2X42L**	†	TXV	40,500	0.77	11.00		13.00		
		EB*2X42L**	*9MPV125	TDR&TXV	40,500	0.77	11.20	13.50			
		EB*2X48F**	†	TXV	40,500	0.77	11.00		13.00		
		EB*2X48F**	*8MPV075	TDR&TXV	40,500	0.77	11.00	13.20			
EB*2X48F**		*9MPV075	TDR&TXV	40,000	0.77	11.00	13.20				
EB*2X48J**		†	TXV	41,000	0.77	11.00		13.00			
EB*2X48J**		*8MPV100	TDR&TXV	41,000	0.77	11.20	13.50				
^EB*2X48J**		*8MPV125	TDR&TXV	41,000	0.77	11.50	14.00				
EB*2X48J**		*9MPV100	TDR&TXV	41,000	0.77	11.20	13.50				
^EB*2X48J**		MV16J22****	TDR&TXV	41,500	0.77	11.50	14.00				
EB*2X48L**		†	TXV	41,000	0.77	11.00		13.00			
EB*2X48L**		*9MPV125	TDR&TXV	41,500	0.77	11.20	13.50				
ED*2X42J**		†	TXV	40,500	0.77	11.00		13.00			
ED*2X42J**		*8MPV100	TDR&TXV	40,500	0.77	11.20	13.50				
ED*2X42J**		*8MPV125	TDR&TXV	40,500	0.77	11.20	13.50				
ED*2X42J**		*9MPV100	TDR&TXV	40,500	0.77	11.00	13.20				
^ED*2X42J**		MV16J22****	TDR&TXV	40,500	0.77	11.50	14.00				
ED*2X42L**		†	TXV	40,500	0.77	11.00		13.00			
ED*2X42L**		*9MPV125	TDR&TXV	40,500	0.77	11.20	13.50				
ED*2X48F**		†	TXV	40,500	0.77	11.00		13.00			
ED*2X48F**		*8MPV075	TDR&TXV	40,500	0.77	11.00	13.20				
ED*2X48F**		*9MPV075	TDR&TXV	40,000	0.77	11.00	13.20				
ED*2X48J**		†	TXV	41,000	0.77	11.00		13.00			
ED*2X48J**		*8MPV100	TDR&TXV	41,000	0.77	11.20	13.50				
ED*2X48J**		*8MPV125	TDR&TXV	41,500	0.77	11.20	13.50				
ED*2X48J**		*9MPV100	TDR&TXV	41,000	0.77	11.20	13.50				
^ED*2X48J**		MV16J22****	TDR&TXV	41,500	0.77	11.50	14.00				
ED*2X48L**		†	TXV	41,000	0.77	11.00		13.00			
ED*2X48L**	*9MPV125	TDR&TXV	41,500	0.77	11.20	13.50					
EHD2X42A**	†	TXV	40,500	0.77	11.00		13.00				
EHD2X42A**	*8MPV075	TDR&TXV	40,500	0.77	11.00	13.20					
EHD2X42A**	*8MPV100	TDR&TXV	40,500	0.77	11.20	13.50					
EHD2X42A**	*8MPV125	TDR&TXV	40,500	0.77	11.20	13.50					
EHD2X42A**	*9MPV075	TDR&TXV	40,500	0.77	11.00	13.20					
EHD2X42A**	*9MPV100	TDR&TXV	40,500	0.77	11.20	13.50					
EHD2X42A**	*9MPV125	TDR&TXV	40,500	0.77	11.20	13.50					

^ Indicates ENERGY STAR compliance for combinations with both: SEER 14.0 or higher and EER 11.5 or higher.

‡ For coils not listed with a matching furnace or blower, coil rating applies with any indoor blower device.

- continued on next page -

COOLING PERFORMANCE FOR COMBINATION RATINGS (continued)										
Indoor Models										
Outdoor Model	Current Indoor Model († tested combo)	Furnace Model	Factory Installed	Cooling (95 °F)			SEER			
				BTU/hr	S/T	EER	factory	w/ field TDR	w/ field R-22 TXV	w/ field R-22 TXV + TDR
N2A342AKA N2A342GKA (continued)	^EHD2X42A**	MV16J22****	TDR&TXV	40,500	0.77	11.50	14.00			
	^EHD2X42A**	MV20N26****	TDR&TXV	40,500	0.77	11.50	14.00			
	EHD2X48A**	†	TXV	40,000	0.77	11.00		13.00		
	EHD2X48A**	*8MPV075	TDR&TXV	40,000	0.77	11.00	13.20			
	EHD2X48A**	*8MPV100	TDR&TXV	40,000	0.77	11.20	13.50			
	EHD2X48A**	*8MPV125	TDR&TXV	40,000	0.77	11.20	13.50			
	EHD2X48A**	*9MPV075	TDR&TXV	40,000	0.77	11.00	13.20			
	EHD2X48A**	*9MPV100	TDR&TXV	40,000	0.77	11.20	13.50			
	EHD2X48A**	*9MPV125	TDR&TXV	40,000	0.77	11.20	13.50			
	^EHD2X48A**	MV16J22****	TDR&TXV	40,000	0.77	11.50	14.00			
	^EHD2X48A**	MV20N26****	TDR&TXV	40,000	0.77	11.50	14.00			
	EMA2X48D**	†	TXV	40,000	0.77	11.00		13.00		
	FEM2X42****	†	TDR&TXV	41,500	0.77	11.20	13.50			
	^FEM2X48****	†	TDR&TXV	42,000	0.77	11.50	14.00			
	FS(M,U)2X42****	†	TDR&TXV	40,500	0.77	11.00	13.00			
FS(M,U)2X48****	†	TDR&TXV	41,000	0.77	11.00	13.00				
N2A348AKA N2A348GKA	†EB*2X48J**	†	TXV	46,000	0.76	11.00		13.00		
	EB*2X48F**	†	TXV	45,000	0.76	11.00		13.00		
	EB*2X48J**	*8MPV100	TDR&TXV	46,000	0.76	11.00	13.20			
	EB*2X48J**	*8MPV125	TDR&TXV	46,500	0.76	11.00	13.20			
	EB*2X48J**	*9MPV100	TDR&TXV	45,000	0.76	11.00	13.20			
	EB*2X48J**	MV16J22****	TDR&TXV	47,000	0.76	11.20	13.50			
	EB*2X48L**	†	TXV	46,000	0.76	11.00		13.00		
	EB*2X48L**	*9MPV125	TDR&TXV	46,000	0.76	11.00	13.20			
	EB*2X60J**	†	TXV	47,500	0.76	11.00		13.00		
	EB*2X60J**	*8MPV100	TDR&TXV	48,000	0.76	11.00	13.20			
	EB*2X60J**	*8MPV125	TDR&TXV	48,000	0.76	11.20	13.50			
	EB*2X60J**	*9MPV100	TDR&TXV	47,500	0.76	11.00	13.20			
	^EB*2X60J**	MV16J22****	TDR&TXV	48,500	0.76	11.50	14.00			
	EB*2X60L**	†	TXV	47,500	0.76	11.00		13.00		
	EB*2X60L**	*9MPV125	TDR&TXV	47,500	0.76	11.20	13.50			
	ED*2X48F**	†	TXV	45,000	0.76	11.00		13.00		
	ED*2X48J**	†	TXV	46,000	0.76	11.00		13.00		
	ED*2X48J**	*8MPV100	TDR&TXV	46,000	0.76	11.00	13.20			
	ED*2X48J**	*8MPV125	TDR&TXV	46,500	0.76	11.00	13.20			
	ED*2X48J**	*9MPV100	TDR&TXV	45,000	0.76	11.00	13.20			
	ED*2X48J**	MV16J22****	TDR&TXV	47,000	0.76	11.20	13.50			
	ED*2X48L**	†	TXV	46,000	0.76	11.00		13.00		
	ED*2X48L**	*9MPV125	TDR&TXV	46,000	0.76	11.00	13.20			
	ED*2X60J**	†	TXV	47,500	0.76	11.00		13.00		
	ED*2X60J**	*8MPV100	TDR&TXV	48,000	0.76	11.00	13.20			
	ED*2X60J**	*8MPV125	TDR&TXV	48,000	0.76	11.00	13.20			
	ED*2X60J**	*9MPV100	TDR&TXV	47,500	0.76	11.00	13.20			
	^ED*2X60J**	MV16J22****	TDR&TXV	48,500	0.76	11.50	14.00			
	ED*2X60L**	†	TXV	47,500	0.76	11.00		13.00		
	ED*2X60L**	*9MPV125	TDR&TXV	47,500	0.76	11.20	13.50			
	EHD2X48A**	†	TXV	46,000	0.76	11.00		13.00		
	EHD2X48A**	*8MPV100	TDR&TXV	45,500	0.76	11.20	13.50			
	EHD2X48A**	*8MPV125	TDR&TXV	45,500	0.76	11.00	13.20			
	EHD2X48A**	*9MPV100	TDR&TXV	45,500	0.76	11.00	13.20			
	EHD2X48A**	*9MPV125	TDR&TXV	45,500	0.76	11.00	13.20			
	EHD2X48A**	MV16J22****	TDR&TXV	45,500	0.76	11.20	13.50			
	EHD2X48A**	MV20N26****	TDR&TXV	45,500	0.76	11.20	13.50			
	EHD2X60A**	†	TXV	47,500	0.76	11.00		13.00		
	EHD2X60A**	*8MPV100	TDR&TXV	47,000	0.76	11.20	13.50			
	EHD2X60A**	*8MPV125	TDR&TXV	47,000	0.76	11.20	13.50			
	EHD2X60A**	*9MPV100	TDR&TXV	47,000	0.76	11.00	13.20			
	EHD2X60A**	*9MPV125	TDR&TXV	47,000	0.76	11.20	13.50			
	^EHD2X60A**	MV16J22****	TDR&TXV	47,000	0.76	11.50	14.00			
	^EHD2X60A**	MV20N26****	TDR&TXV	47,000	0.76	11.50	14.00			
	EMA2X48D**	†	TXV	45,000	0.76	11.00		13.00		
FEM2X48****	†	TDR&TXV	47,500	0.76	11.20	13.50				
^FEM2X60****	†	TDR&TXV	48,500	0.76	11.50	14.00				
FS(M,U)2X48****	†	TDR&TXV	47,000	0.76	11.00	13.00				
FS(M,U)2X60****	†	TDR&TXV	48,000	0.76	11.00	13.00				
^FVM2X48****	†	TDR&TXV	47,000	0.76	12.00	14.00				
^FVM2X60****	†	TDR&TXV	47,500	0.76	12.00	14.00				

^ Indicates ENERGY STAR compliance for combinations with both: SEER 14.0 or higher and EER 11.5 or higher.

† For coils not listed with a matching furnace or blower, coil rating applies with any indoor blower device.

- continued on next page -

COOLING PERFORMANCE FOR COMBINATION RATINGS (continued)										
Indoor Models										
Outdoor Model	Current Indoor Model (‡ tested combo)	Furnace Model	Factory Installed	Cooling (95 ° F)			SEER			
				BTU/hr	S/T	EER	factory	w/ field TDR	w/ field R-22 TXV	w/ field R-22 TXV + TDR
N2A360AKB N2A360GKB	‡EB*2X60L**	†	TXV	56,000	0.75	11.00		13.00		
	EB*2X60J**	†	TXV	56,000	0.75	11.00		13.00		
	EB*2X60J**	MV16J22**B*	TDR&TXV	56,000	0.75	11.50	13.50			
	EB*2X60L**	MV20L24**B*	TDR&TXV	56,000	0.75	11.50	13.50			
	ED*2X60J**	†	TXV	56,000	0.75	11.00		13.00		
	ED*2X60J**	MV16J22**B*	TDR&TXV	56,000	0.75	11.50	13.50			
	ED*2X60L**	†	TXV	56,000	0.75	11.00		13.00		
	ED*2X60L**	MV20L24**B*	TDR&TXV	56,000	0.75	11.50	13.50			
	EHD2X60A**	†	TXV	56,000	0.75	11.00		13.00		
	EHD2X60A**	MV16J22**B*	TDR&TXV	56,000	0.75	11.50	13.50			
	EHD2X60A**	MV20L24**B*	TDR&TXV	56,000	0.75	11.50	13.50			
	FS(M,U)2X60****	†	TDR&TXV	56,000	0.75	11.00	13.00			
	FEM2X60****	†	TDR&TXV	56,000	0.75	11.50	13.20			
FVM2X60****	†	TDR&TXV	56,500	0.75	11.70	13.50				

^ Indicates ENERGY STAR compliance for combinations with both: SEER 14.0 or higher and EER 11.5 or higher.  
 † For coils not listed with a matching furnace or blower, coil rating applies with any indoor blower device.



This product has been designed and manufactured to meet ENERGY STAR criteria for energy efficiency when matched with appropriate coil components. However, proper refrigerant charge and proper air flow are critical to achieve rated capacity and efficiency. Installation of this product should follow the manufacturer's refrigerant charging and air flow instructions. Failure to confirm proper charge and airflow may reduce energy efficiency and shorten equipment life.

<b>OUTDOOR UNIT MODEL NUMBER IDENTIFICATION GUIDE (single phase)</b>											
Digit Position:	1	2	3	4	5, 6	7	8	9	10	11	12
Example Part Number:	<b>N</b>	<b>2</b>	<b>A</b>	<b>3</b>	<b>18</b>	<b>A</b>	<b>K</b>	<b>B</b>	<b>1</b>	<b>0</b>	<b>0</b>
H = Arcoaire Mainline N = Arcoaire Entry <b>BRANDING</b> 2 = R-22 4 = R-410A <b>REFRIGERANT</b> A = Air Conditioner H = Heat Pump <b>TYPE</b> 3 = 13 SEER 4 = 14 SEER <b>NOMINAL EFFICIENCY</b> 18 = 18,000 BTUH = 1½ tons 24 = 24,000 BTUH = 2 tons 30 = 30,000 BTUH = 2½ tons 36 = 36,000 BTUH = 3 tons 42 = 42,000 BTUH = 3½ tons 48 = 48,000 BTUH = 4 tons 60 = 60,000 BTUH = 5 tons <b>NOMINAL CAPACITY</b> A = Standard Grille G = Coil Guard Grille C = Coastal <b>FEATURES</b> K = 208/230-1-60 <b>VOLTAGE</b> Sales Code Engineering Revision Extra Digit Extra Digit											

<b>ACCESSORIES PART NUMBER IDENTIFICATION GUIDE</b>									
Digit Position:	1	2	3	4	5	6, 7	8, 9	10, 11	
Example Part Number:	<b>N</b>	<b>A</b>	<b>S</b>	<b>A</b>	<b>0</b>	<b>01</b>	<b>01</b>	<b>CH</b>	
N = Non-Branded <b>BRANDING</b> A = Accessory <b>PRODUCT GROUP</b> S = Split System (AC & HP) <b>KIT USAGE</b> A = Original B = 2nd Generation <b>MAJOR SERIES</b> 0 = Generic or Not Applicable 2 = R-22 4 = R-410A <b>REFRIGERANT</b> Product Identifier Number Package Quantity Type of Kit (Example: CH = Crankcase Heater)									