

EFFICIENT 13 SEER 3-PHASE HEAT PUMP

3 THRU 5 TONS SPLIT SYSTEM

208 / 230 Volt, 3-phase, 60 Hz

460 Volt, 3-phase, 60 Hz

REFRIGERATION CIRCUIT

- Copeland® compressors on all models
- Suction line accumulator factory installed
- Bi-flow filter-drier supplied with every unit for field installation
- Integrated solid state control with Time-Temperature Defrost
- Low pressure switch
- Copper tube / aluminum fin coil

EASY TO INSTALL AND SERVICE

- Phase Monitor board detects issues with 3-phase line voltage
- Easy Access service valves on all models
- External high and low refrigerant service ports
- Only two screws to access control panel
- Factory charged with R-22 refrigerant

BUILT TO LAST

- Baked-on powder coat finish over galvanized steel
- Post-painted (black) coil fins
- Coated, weather-resistant cabinet screws
- Coated inlet grille with 2" (51mm) spacing standard, alternate models available with 3/8" (10mm) grille spacing for extra protection

WARRANTY

- 5 year compressor limited warranty
- 1 year parts limited warranty



Rated in accordance with ARI Standard 240. Certification applies only when used with proper components as listed with ARI.



Model Number	Voltage	Size (tons)	Nominal Btu/hr	Min. Circuit Ampacity	Max. Fuse or Breaker	Operating Dim's h x w x d in. (mm)	Ship / Operating Weight lbs. (kg)
N2H336*HB	208/230	3	36,000	14.1	20	32 ⁵ / ₁₆ x 35 x 35 (821 x 889 x 889)	225 / 187 (102 / 85)
N2H336*LB	460			6.9	15		
N2H342*HB	208/230	3½	42,000	17.2	25	39 ⁷ / ₈ x 35 x 35 (969 x 889 x 889)	239 / 203 (108 / 92)
N2H342*LB	460			8.1	15		
N2H348*HB	208/230	4	48,000	18.4	30	28 ¹⁵ / ₁₆ x 35 x 35 (735 x 889 x 889)	264 / 229 (120 / 104)
N2H348*LB	460			9.4	15		
N2H360*HC	208/230	5	60,000	22.8	40	32 ¹⁵ / ₁₆ x 35 x 35 (837 x 889 x 889)	303 / 271 (137 / 123)
N2H360*LC	460			10.4	15		

* = A for standard inlet grille, * = G for inlet grille with 3/8" (10mm) spacing for extra protection

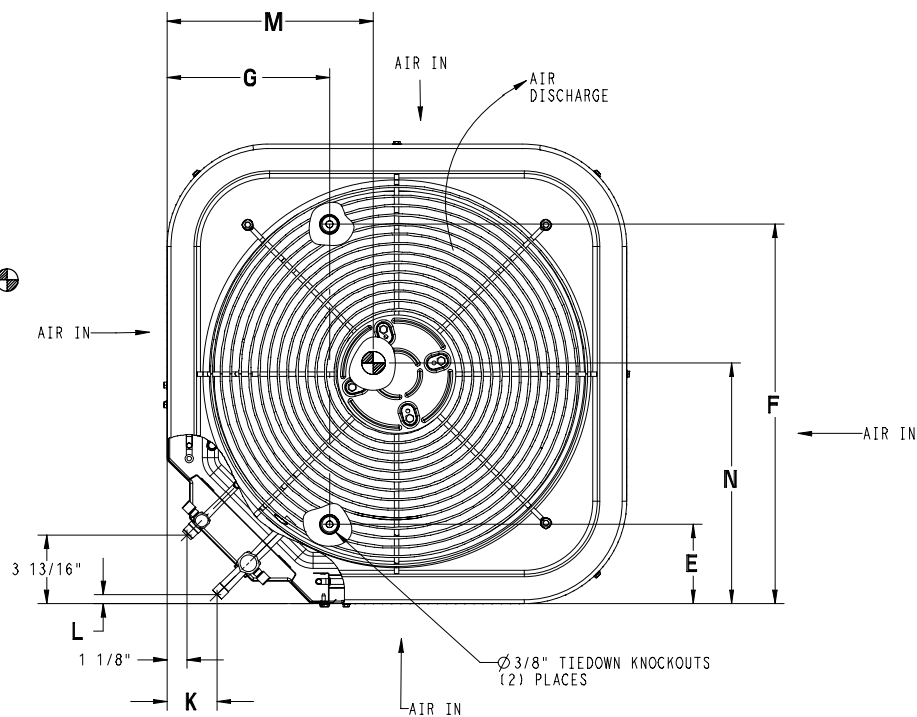
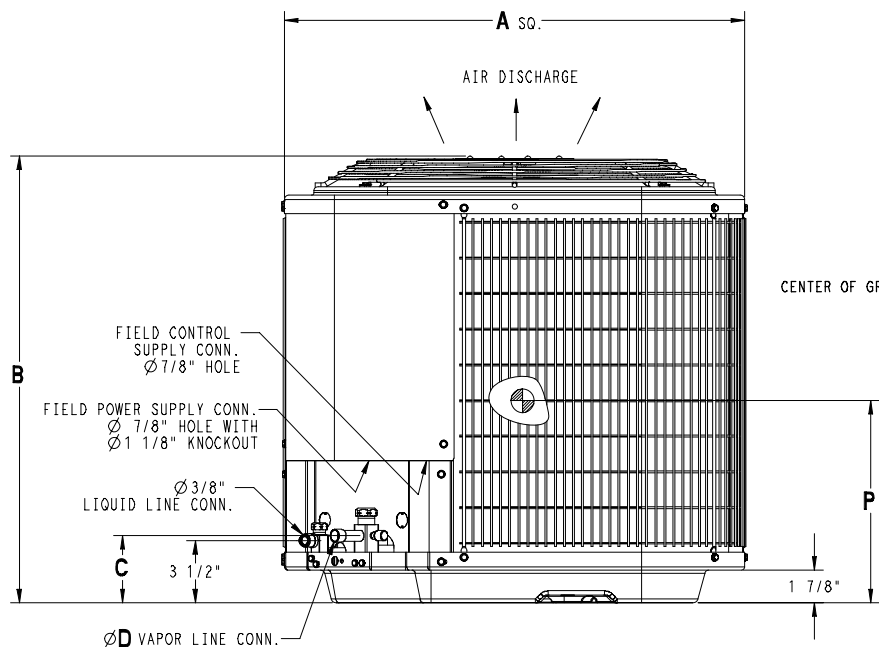

All Dimensions Inches (English)

Model (* = A or G)	All Dimensions Inches (English)												Minimum Mounting Pad Size	Crated Dimensions B(h) x A(w) x R(d)
	A	B	C	D	E	F	G	K	L	M	N	P		
N2H336*HB N2H336*LB	35	32 ⁵ / ₁₆	3 ³ / ₄	³ / ₄	6 ⁶ / ₁₆	28 ⁷ / ₁₆	9 ¹ / ₈	2 ¹³ / ₁₆	¹ / ₂	17	16	16	35 x 35	35 ¹⁵ / ₁₆ x 39 ⁵ / ₁₆ x 36 ¹ / ₈
N2H342*HB N2H342*LB	35	39 ¹ / ₈	3 ⁷ / ₈	⁷ / ₈	6 ⁶ / ₁₆	28 ⁷ / ₁₆	9 ¹ / ₈	2 ¹⁵ / ₁₆	⁵ / ₈	16 ¹ / ₂	16	17	35 x 35	42 ³ / ₄ x 39 ⁵ / ₁₆ x 36 ¹ / ₈
N2H348*HB N2H348*LB	35	28 ¹⁵ / ₁₆	3 ⁷ / ₈	⁷ / ₈	6 ⁶ / ₁₆	28 ⁷ / ₁₆	9 ¹ / ₈	2 ¹⁵ / ₁₆	⁵ / ₈	18 ¹ / ₂	18	17 ¹ / ₂	35 x 35	32 ⁹ / ₁₆ x 39 ⁵ / ₁₆ x 36 ¹ / ₈
N2H360*HC N2H360*LC	35	32 ⁵ / ₁₆	3 ⁷ / ₈	⁷ / ₈	6 ⁶ / ₁₆	28 ⁷ / ₁₆	9 ¹ / ₈	2 ¹³ / ₁₆	⁵ / ₈	16	13	13 ³ / ₄	35 x 35	35 ¹⁵ / ₁₆ x 39 ⁵ / ₁₆ x 36 ¹ / ₈

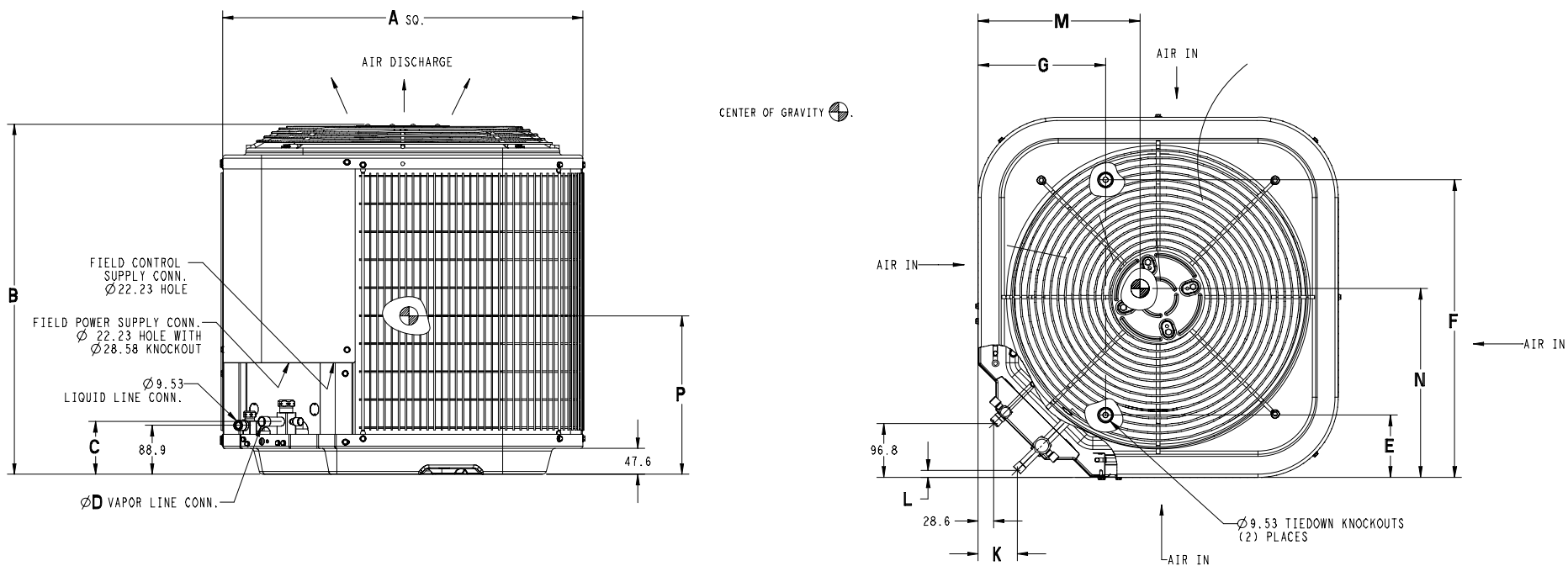

Model (* = A or G)	All Dimensions mm (SI Metric)												Minimum Mounting Pad Size	Crated Dimensions B(h) x A(w) x R(d)
	A	B	C	D	E	F	G	K	L	M	N	P		
N2H336*HB N2H336*LB	889	821	95	19	167	722	232	71	13	432	406	406	889 x 889	913 x 999 x 918
N2H342*HB N2H342*LB	889	994	98	22	167	722	232	74	16	419	406	432	889 x 889	1086 x 999 x 918
N2H348*HB N2H348*LB	889	735	98	22	167	722	232	74	16	470	457	445	889 x 889	827 x 999 x 918
N2H360*HC N2H360*LC	889	821	98	22	167	722	232	71	16	409	330	349	889 x 889	913 x 999 x 918

PHYSICAL DATA				
Model Size	36	42	48	60
Nominal Cooling Capacity (BTU/hr)	36,000	42,000	48,000	60,000
Nominal SEER	13.0	13.0	13.0	13.0
Sound Rating (dBA) **	74	76	76	76
PSC Fan Motor HP	1/8	1/5	1/4	1/4
Fan RPM	800	800	800	800
Fan CFM	3334	3810	4046	4046
Coil Face Area ft ² (m ²)	20.12 (1.9)	25.15 (2.3)	17.60 (1.6)	20.12 (1.9)
Coil Rows – fins per inch	1 – 20	1 – 20	2 – 20	2 – 20
Low Pressure Switch Open Pressure Close Pressure	7 ± 3 PSIG 22 ± 5 PSIG	7 ± 3 PSIG 22 ± 5 PSIG	7 ± 3 PSIG 22 ± 5 PSIG	7 ± 3 PSIG 22 ± 5 PSIG
Liquid Line Connection Size in. (mm)	3/8 (10)	3/8 (10)	3/8 (10)	3/8 (10)
Vapor Line Connection Size in. (mm)	3/4 (19)	7/8 (22)	7/8 (22)	7/8 (22)
Recommended Line Set Liquid Tube Diameter in. (mm)	3/8 (10)	3/8 (10)	3/8 (10)	3/8 (10)
Recommended Line Set Vapor Tube Diameter in. (mm)*	3/4 (19) *	7/8 (22) *	7/8 (22) *	1 1/8 (29) *
*Recommended Vapor Tube Line size is for standard installations. These recommendations may not apply to “Long Line” installations. When the total equivalent line length exceeds 80 feet (24m) or there is more than 20 feet (6.1m) vertical separation between indoor and outdoor units, consult the Long Line Application Guideline document before purchasing/installing line sets.				
Factory Charge R-22 lbs. (kg)	7.80 (3.54)	10.00 (4.54)	12.00 (5.44)	13.5 (6.11)
Required Subcooling °F (°C)	11 (6)	11 (6)	12 (7)	12 (7)
Weight, shipping lbs. (kg)	233 (106)	254 (115)	290 (132)	303 (137)
Weight, operating lbs. (kg)	202 (92)	225 (102)	259 (117)	271 (123)

ELECTRICAL DATA								
Model Size (* = A or G)	36*HB	36*LB	42*HB	42*LB	48*HB	48*LB	60*HC	60*LC
Supply Voltage, 3-phase 60 Hz.	208/230	460	208/230	460	208/230	460	208/230	460
Acceptable Voltage Range, min-max	197-253	414-506	197-253	414-506	197-253	414-506	197-253	414-506
Minimum Circuit Ampacity – MCA (amps)	14.1	6.9	17.2	8.1	18.4	9.4	22.8	10.4
Maximum OverCurrent Protective device – MOCP (amps)	20	15	25	15	30	15	40	15
Compr. RLA (Rated Load Amps) LRA (Locked Rotor Amps)	10.7 77	5.1 39	12.8 88	5.8 44	13.8 91	7.1 46	17.3 123	6.7 49.5
Fan Motor FLA (Full Load Amps)	0.7	0.5	1.2	0.5	1.2	0.6	1.2	0.6

**Sound Rating tested in accordance with ARI Standard 270-95 (not listed with ARI).

R-22 COOLING CAPACITY LOSS FOR VARIOUS LINE LENGTHS & TUBE DIAMETERS															
Model Size	Liquid Line in.(mm)	Acceptable Vapor Line Sizes in.(mm)	Cooling Capacity Loss (%) at Total Equivalent Line Length feet (m) Refer to Long Line Application Guideline to calculate equivalent length												
			Standard Application			Long Line Application (Requires Accessories) *									
			25' (7.6)	50' (15.2)	80' (24.4)	81' (24.7)	100' (30.5)	125' (38.1)	150' (45.7)	175' (53.3)	200' (61)	225' (68.6)	250' (76.2)		
36	3/8 (10)	3/4 (19)	0	1	2	2	3	4	5	6	7	8	9		
		7/8 (22)	0	0	1	1	1	2	2	3	3	4	4		
42		7/8 (22)	0	1	1	1	2	2	3	4	4	5	5		
48		7/8 (22)	0	1	2	2	2	3	4	5	5	6	7		
60		7/8 (22)	1	2	3	3	4	5	7	8	9	10	11		
		1-1/8 (29)	0	0	1	1	1	1	2	2	2	3	3		

* Applications are considered “Long Line” if the total equivalent tubing length exceeds 80 feet (24.4m) or there is more than 20 foot (6.1m) vertical separation between indoor and outdoor units. These applications require additional accessories and system modifications for reliable system operation. Refer to the Long Line Application Guideline document for required piping and system modifications. Refer to Accessory Usage Guidelines below for required accessories.

Applications in the shaded area may have height restrictions that limit allowable total equivalent length when outdoor unit is below indoor unit. Refer to the Long Line Application Guideline document for instructions.

The maximum allowable total equivalent length is 250 feet (76.2m).

ACCESSORY USAGE GUIDELINES			
Accessory	REQUIRED FOR APPLICATIONS IN SNOW-BELT REGION	REQUIRED FOR LOW-AMBIENT APPLICATIONS {Below 55° F(13° C)}	REQUIRED FOR LONG-LINE APPLICATIONS* {Over 80 Ft.(24.4m)}
Crankcase Heater	Standard (if required)	Yes	Yes
Evaporator Freeze Thermostat	No	Yes	No
Accumulator	Standard (factory installed)	Standard (factory installed)	Standard (factory installed)
Low Ambient Pressure Switch	No	Yes	No
Support Feet, 4”(102mm) tall	Yes	Recommended	No
Liquid Line Solenoid Valve	No	No	See Long-Line Application Guideline

* For Line Set lengths between 80 and 200 ft (24.4 and 61m) horizontal. or more than 20 ft (6.1m) indoor-outdoor vertical separation, refer to the Long Line Application Guideline document.

ACCESSORIES		
Part Number	Description	Used On Model Size
NASA001FS	Evaporator Freeze Thermostat	ALL
NASA001LS	Liquid Line Solenoid Valve, HP, R-22 or R-410A	ALL
NASA001TD	Time Delay Relay, Indoor Blower	ALL
NASA001AC	Anti-Cycle Timer (5 minute delay)	ALL
NASA204PS	High Pressure Switch, AC or HP, R-22*	ALL
NASA201LA	Low Ambient Kit (Pressure Switch), R-22	ALL
NASA001SF	Support Feet, 4” (102mm) tall	ALL
NASA00106SS	Snow Stand	ALL
NASA001SJ	Sound Jacket, Compressor	36, 42, 48
NASA003SJ	Sound Jacket, Compressor	60
AMF153TKB	TXV Kit, R-22 (converts R-22 piston coils to R-22 TXV)	36
AMF355TKB	TXV Kit, R-22 (converts R-22 piston coils to R-22 TXV)	42, 48, 60
AXWR01DFC	Fossil Fuel Kit	ALL

*Dual Fuel applications require High Pressure Switch.

COOLING & HEATING PERFORMANCE FOR COMBINATION RATINGS
Indoor Models

Outdoor Model	Current Indoor Model (‡ tested combo)	Furnace Model	Factory Installed	Cool 95° F (35° C)			SEER		Heat 47° F (8.3° C)		Heat 17° F (-8.3° C)		HSPF
				BTU/hr	S / T	EER	factory	with field TDR	BTU/hr	COP	BTU/hr	COP	
N2H336*HB N2H336*LB	‡FEM2X35***	†	TDR&TXV	34,600	0.76	10.80	13.00		34,400	3.46	20,600	2.44	8.0
	EB*2X36B**	MV08B15**B*	TDR&TXV	34,000	0.76	11.00	13.00		34,800	3.50	20,200	2.44	8.0
	EB*2X36F**	MV12F19**B*	TDR&TXV	34,200	0.76	11.00	13.00		34,000	3.54	20,200	2.48	8.1
	EB*2X36J**	*8MPV100	TDR&TXV	34,800	0.76	11.00	13.20		34,000	3.50	20,600	2.46	8.1
	EB*2X36J**	*8MPV125	TDR&TXV	34,800	0.76	11.00	13.20		34,200	3.52	20,400	2.48	8.1
	EB*2X36J**	*9MPV100	TDR&TXV	34,600	0.76	10.80	13.00		34,400	3.48	20,600	2.44	8.0
	EB*2X36J**	MV16J22**B*	TDR&TXV	34,200	0.76	11.20	13.50		34,000	3.56	20,000	2.48	8.1
	EB*2X42F**	*8MPV075	TDR&TXV	34,600	0.76	10.80	13.00		34,000	3.46	20,600	2.44	8.0
	EB*2X42F**	MV12F19**B*	TDR&TXV	34,600	0.76	11.20	13.50		34,000	3.56	20,200	2.50	8.0
	EB*2X42J**	*8MPV100	TDR&TXV	35,000	0.76	11.00	13.20		32,800	3.48	20,600	2.48	8.1
	EB*2X42J**	*8MPV125	TDR&TXV	35,000	0.76	11.00	13.20		33,000	3.50	20,400	2.50	8.1
	EB*2X42J**	*9MPV100	TDR&TXV	34,800	0.76	10.80	13.00		33,200	3.46	20,600	2.46	8.0
	EB*2X42J**	*9MVX080	TDR&TXV	35,000	0.76	10.80	13.00		32,600	3.44	20,600	2.46	7.9
	EB*2X42J**	MV16J22**B*	TDR&TXV	34,600	0.76	11.20	13.50		33,400	3.58	20,200	2.50	8.0
	EB*2X42L**	*9MPV125	TDR&TXV	35,000	0.76	11.00	13.20		33,200	3.48	20,600	2.48	8.1
	EB*2X42L**	*9MVX100	TDR&TXV	34,800	0.76	11.00	13.20		33,400	3.50	20,400	2.48	8.0
	EB*2X42L**	MV20L24**B*	TDR&TXV	34,600	0.76	11.20	13.50		33,400	3.58	20,000	2.50	8.0
	ED*2X36B**	MV08B15**B*	TDR&TXV	34,000	0.76	11.00	13.00		34,600	3.50	20,200	2.44	8.0
	ED*2X36F**	MV12F19**B*	TDR&TXV	34,200	0.76	11.00	13.00		34,000	3.54	20,200	2.48	8.0
	ED*2X36J**	*8MPV100	TDR&TXV	34,800	0.76	11.00	13.20		34,000	3.50	20,600	2.46	8.1
	ED*2X36J**	*8MPV125	TDR&TXV	34,800	0.76	11.00	13.20		34,200	3.52	20,400	2.48	8.1
	ED*2X36J**	*9MPV100	TDR&TXV	34,600	0.76	10.80	13.00		34,400	3.48	20,600	2.44	8.0
	ED*2X36J**	MV16J22**B*	TDR&TXV	34,200	0.76	11.20	13.50		34,000	3.56	20,000	2.48	8.0
	ED*2X42F**	*8MPV075	TDR&TXV	34,600	0.76	10.80	13.00		34,000	3.46	20,600	2.44	8.0
	ED*2X42F**	MV12F19**B*	TDR&TXV	34,600	0.76	11.20	13.50		34,000	3.56	20,200	2.50	8.0
	ED*2X42J**	*8MPV100	TDR&TXV	35,000	0.76	11.00	13.20		32,800	3.48	20,600	2.48	8.0
	ED*2X42J**	*8MPV125	TDR&TXV	35,000	0.76	11.00	13.20		33,000	3.50	20,400	2.50	8.1
	ED*2X42J**	*9MPV100	TDR&TXV	34,800	0.76	10.80	13.00		33,200	3.46	20,600	2.46	8.0
	ED*2X42J**	*9MVX080	TDR&TXV	35,000	0.76	10.80	13.00		32,600	3.44	20,600	2.46	7.9
	ED*2X42J**	MV16J22**B*	TDR&TXV	34,800	0.76	11.20	13.50		33,600	3.58	20,200	2.50	8.0
ED*2X42L**	*9MPV125	TDR&TXV	35,000	0.76	11.00	13.20		33,200	3.48	20,600	2.48	8.0	

ENERGY STAR compliance for combinations with: SEER 13.00 or higher and HSPF 7.7 or higher. (3-phase)

† For coils not listed with a matching furnace or blower, coil rating applies with any indoor blower device.

- continued on next page -

COOLING & HEATING PERFORMANCE FOR COMBINATION RATINGS (continued)
Indoor Models

Outdoor Model	Current Indoor Model (‡ tested combo)	Furnace Model	Factory Installed	Cool 95° F (35° C)			SEER		Heat 47° F (8.3° C)		Heat 17° F (-8.3° C)		HSPF
				BTU/hr	S / T	EER	factory	with field TDR	BTU/hr	COP	BTU/hr	COP	
N2H336*HB N2H336*LB (continued)	ED*2X42L**	*9MVX100	TDR&TXV	34,800	0.76	11.00	13.20		33,600	3.50	20,400	2.48	8.0
	ED*2X42L**	MV20L24**B*	TDR&TXV	34,800	0.76	11.20	13.50		33,600	3.58	20,000	2.50	8.0
	EHD2X36A**	*8MPV075	TDR&TXV	35,200	0.76	11.00	13.20		32,200	3.40	20,600	2.46	8.0
	EHD2X36A**	*8MPV100	TDR&TXV	35,600	0.76	11.00	13.20		31,000	3.40	20,600	2.50	8.0
	EHD2X36A**	*8MPV125	TDR&TXV	35,400	0.76	11.20	13.50		31,400	3.44	20,600	2.52	8.0
	EHD2X36A**	*9MPV100	TDR&TXV	35,400	0.76	11.00	13.20		31,400	3.38	20,800	2.48	8.0
	EHD2X36A**	*9MPV125	TDR&TXV	35,400	0.76	11.00	13.20		31,400	3.42	20,600	2.50	8.1
	EHD2X36A**	*9MVX080	TDR&TXV	35,400	0.76	11.00	13.20		29,600	3.34	20,800	2.48	7.9
	EHD2X36A**	*9MVX100	TDR&TXV	35,200	0.76	11.00	13.20		31,200	3.44	20,600	2.48	8.0
	EHD2X36A**	MV08B15**B*	TDR&TXV	35,000	0.76	11.00	13.00		32,000	3.52	20,400	2.50	8.0
	EHD2X36A**	MV12F19**B*	TDR&TXV	35,200	0.76	11.00	13.20		32,000	3.54	20,200	2.52	8.0
	EHD2X36A**	MV16J22**B*	TDR&TXV	35,200	0.76	11.20	13.50		32,000	3.56	20,200	2.52	8.0
	EHD2X36A**	MV20L24**B*	TDR&TXV	35,200	0.76	11.20	13.50		32,000	3.54	20,200	2.52	8.0
	EHD2X42A**	*8MPV075	TDR&TXV	35,400	0.76	11.00	13.20		30,600	3.34	20,800	2.48	8.0
	EHD2X42A**	*8MPV100	TDR&TXV	35,800	0.76	11.20	13.50		29,400	3.32	20,800	2.52	8.0
	EHD2X42A**	*8MPV125	TDR&TXV	35,800	0.76	11.20	13.50		29,600	3.36	20,600	2.54	8.0
	EHD2X42A**	*9MPV075	TDR&TXV	35,200	0.76	10.80	13.00		31,400	3.34	20,800	2.44	7.9
	EHD2X42A**	*9MPV100	TDR&TXV	35,600	0.76	11.00	13.20		29,800	3.32	20,800	2.50	8.0
	EHD2X42A**	*9MPV125	TDR&TXV	35,800	0.76	11.20	13.50		29,800	3.34	20,600	2.52	8.0
	EHD2X42A**	*9MVX080	TDR&TXV	35,800	0.76	11.00	13.20		27,600	3.28	20,800	2.50	7.9
	EHD2X42A**	*9MVX100	TDR&TXV	35,600	0.76	11.20	13.50		29,000	3.36	20,600	2.50	8.0
	EHD2X42A**	MV08B15**B*	TDR&TXV	35,400	0.76	11.00	13.20		31,000	3.46	20,400	2.52	8.0
	EHD2X42A**	MV12F19**B*	TDR&TXV	35,400	0.76	11.00	13.20		30,800	3.48	20,200	2.54	8.0
	EHD2X42A**	MV16J22**B*	TDR&TXV	35,600	0.76	11.20	13.50		30,800	3.50	20,200	2.54	8.0
	EHD2X42A**	MV20L24**B*	TDR&TXV	35,600	0.76	11.20	13.50		30,800	3.50	20,200	2.54	8.0
	FEM2X36****	†	TDR&TXV	35,400	0.76	11.00	13.20		30,400	3.32	20,800	2.48	8.0
FEM2X42****	†	TDR&TXV	35,400	0.76	10.80	13.00		30,400	3.28	20,800	2.46	7.9	
FVM2X24****	†	TDR&TXV	34,000	0.76	10.80	13.00		36,000	3.60	20,400	2.44	8.0	
FVM2X36****	†	TDR&TXV	34,400	0.76	11.20	13.50		34,600	3.52	20,200	2.46	8.0	
N2H342*HB N2H342*LB	‡FEM2X42****	†	TDR&TXV	41,000	0.75	10.80	13.00		41,000	3.48	24,600	2.42	8.0
	EB*2X42F**	MV12F19**B*	TDR&TXV	40,000	0.75	11.00	13.00		41,500	3.52	24,000	2.44	8.0

ENERGY STAR compliance for combinations with: SEER 13.00 or higher and HSPF 7.7 or higher. (3-phase)

† For coils not listed with a matching furnace or blower, coil rating applies with any indoor blower device.

- continued on next page -

COOLING & HEATING PERFORMANCE FOR COMBINATION RATINGS (continued)
Indoor Models

Outdoor Model	Current Indoor Model († tested combo)	Furnace Model	Factory Installed	Cool 95° F (35° C)			SEER		Heat 47° F (8.3° C)		Heat 17° F (-8.3° C)		HSPF
				BTU/hr	S / T	EER	factory	with field TDR	BTU/hr	COP	BTU/hr	COP	
N2H342*HB N2H342*LB (continued)	EB*2X42J**	*8MPV100	TDR&TXV	40,000	0.75	10.80	13.00		42,000	3.50	24,400	2.42	8.0
	EB*2X42J**	*8MPV125	TDR&TXV	40,000	0.75	11.00	13.20		41,500	3.52	24,200	2.44	8.0
	EB*2X42J**	*9MPV100	TDR&TXV	40,000	0.75	10.80	13.00		42,000	3.46	24,400	2.40	8.0
	EB*2X42J**	MV16J22**B*	TDR&TXV	40,000	0.75	11.00	13.20		41,500	3.54	24,000	2.46	8.0
	EB*2X42L**	*9MPV125	TDR&TXV	40,000	0.75	10.80	13.00		42,000	3.50	24,400	2.42	8.0
	EB*2X42L**	*9MVX100	TDR&TXV	40,000	0.75	10.80	13.00		42,000	3.48	24,200	2.42	8.0
	EB*2X42L**	MV20L24**B*	TDR&TXV	40,000	0.75	11.00	13.20		41,500	3.56	24,000	2.46	8.0
	EB*2X48F**	*8MPV075	TDR&TXV	40,500	0.75	10.80	13.00		39,000	3.42	24,800	2.42	8.0
	EB*2X48F**	MV12F19**B*	TDR&TXV	41,000	0.75	11.00	13.50		39,000	3.54	24,200	2.50	8.2
	EB*2X48J**	*8MPV100	TDR&TXV	41,000	0.75	11.00	13.20		39,500	3.52	24,400	2.46	8.2
	EB*2X48J**	*8MPV125	TDR&TXV	41,000	0.75	11.20	13.50		39,500	3.52	24,400	2.48	8.2
	EB*2X48J**	*9MPV100	TDR&TXV	40,500	0.75	10.80	13.00		40,000	3.48	24,600	2.44	8.1
	EB*2X48J**	*9MVX080	TDR&TXV	41,000	0.75	10.80	13.00		40,000	3.48	24,600	2.44	8.1
	EB*2X48J**	MV16J22**B*	TDR&TXV	40,500	0.75	11.20	13.50		40,000	3.58	24,000	2.50	8.2
	EB*2X48L**	*9MPV125	TDR&TXV	40,500	0.75	11.00	13.20		40,000	3.50	24,400	2.46	8.1
	EB*2X48L**	*9MVX100	TDR&TXV	40,500	0.75	11.00	13.20		40,000	3.50	24,400	2.44	8.1
	EB*2X48L**	MV20L24**B*	TDR&TXV	40,500	0.75	11.20	13.50		39,500	3.58	24,000	2.50	8.2
	ED*2X42F**	MV12F19**B*	TDR&TXV	40,000	0.75	11.00	13.00		41,500	3.52	24,000	2.44	8.0
	ED*2X42J**	*8MPV100	TDR&TXV	40,000	0.75	10.80	13.00		42,000	3.50	24,400	2.42	8.0
	ED*2X42J**	*8MPV125	TDR&TXV	40,000	0.75	11.00	13.20		41,500	3.52	24,200	2.44	8.0
	ED*2X42J**	*9MPV100	TDR&TXV	40,000	0.75	10.80	13.00		42,000	3.46	24,400	2.40	8.0
	ED*2X42J**	MV16J22**B*	TDR&TXV	40,000	0.75	11.00	13.20		41,500	3.54	24,000	2.46	8.0
	ED*2X42L**	*9MPV125	TDR&TXV	40,000	0.75	10.80	13.00		42,000	3.50	24,400	2.42	8.0
	ED*2X42L**	*9MVX100	TDR&TXV	40,000	0.75	10.80	13.00		42,000	3.48	24,200	2.42	8.0
	ED*2X42L**	MV20L24**B*	TDR&TXV	40,000	0.75	11.00	13.20		41,500	3.56	24,000	2.46	8.0
	ED*2X48F**	*8MPV075	TDR&TXV	40,500	0.75	10.80	13.00		39,000	3.42	24,800	2.42	8.0
	ED*2X48F**	MV12F19**B*	TDR&TXV	41,000	0.75	11.00	13.20		39,000	3.54	24,200	2.50	8.0
	ED*2X48J**	*8MPV100	TDR&TXV	41,000	0.75	11.00	13.20		39,500	3.52	24,400	2.46	8.2
	ED*2X48J**	*8MPV125	TDR&TXV	41,000	0.75	11.20	13.50		39,500	3.52	24,400	2.48	8.2
	ED*2X48J**	*9MPV100	TDR&TXV	40,500	0.75	10.80	13.00		40,000	3.48	24,600	2.44	8.1
ED*2X48J**	*9MVX080	TDR&TXV	41,000	0.75	10.80	13.00		40,000	3.48	24,600	2.44	8.1	

ENERGY STAR compliance for combinations with: SEER 13.00 or higher and HSPF 7.7 or higher. (3-phase)

† For coils not listed with a matching furnace or blower, coil rating applies with any indoor blower device.

- continued on next page -

COOLING & HEATING PERFORMANCE FOR COMBINATION RATINGS (continued)
Indoor Models

Outdoor Model	Current Indoor Model (‡ tested combo)	Furnace Model	Factory Installed	Cool 95° F (35° C)			SEER		Heat 47° F (8.3° C)		Heat 17° F (-8.3° C)		HSPF
				BTU/hr	S / T	EER	factory	with field TDR	BTU/hr	COP	BTU/hr	COP	
N2H342*HB N2H342*LB (continued)	ED*2X48J**	MV16J22**B*	TDR&TXV	40,500	0.75	11.20	13.50		40,000	3.58	24,000	2.50	8.2
	ED*2X48L**	*9MPV125	TDR&TXV	40,500	0.75	11.00	13.20		40,000	3.50	24,400	2.46	8.1
	ED*2X48L**	*9MPV100	TDR&TXV	40,500	0.75	10.80	13.20		40,000	3.50	24,400	2.44	8.1
	ED*2X48L**	MV20L24**B*	TDR&TXV	40,500	0.75	11.20	13.50		39,500	3.58	24,000	2.50	8.1
	EHD2X42A**	*8MPV075	TDR&TXV	40,500	0.75	10.80	13.00		41,000	3.48	24,600	2.42	8.0
	EHD2X42A**	*8MPV100	TDR&TXV	41,000	0.75	11.00	13.20		41,000	3.56	24,400	2.46	8.2
	EHD2X42A**	*8MPV125	TDR&TXV	41,000	0.75	11.20	13.50		41,000	3.56	24,400	2.46	8.2
	EHD2X42A**	*9MPV100	TDR&TXV	41,000	0.75	11.00	13.20		41,000	3.52	24,600	2.44	8.1
	EHD2X42A**	*9MPV125	TDR&TXV	41,000	0.75	11.00	13.20		41,000	3.54	24,400	2.44	8.2
	EHD2X42A**	*9MVX080	TDR&TXV	41,000	0.75	10.80	13.20		41,000	3.52	24,600	2.44	8.2
	EHD2X42A**	*9MVX100	TDR&TXV	40,500	0.75	10.80	13.20		41,000	3.54	24,400	2.44	8.2
	EHD2X42A**	MV12F19**B*	TDR&TXV	41,000	0.75	11.20	13.50		41,000	3.60	24,200	2.48	8.2
	EHD2X42A**	MV16J22**B*	TDR&TXV	41,000	0.75	11.20	13.50		40,500	3.62	24,000	2.50	8.2
	EHD2X42A**	MV20L24**B*	TDR&TXV	41,000	0.75	11.20	13.50		40,500	3.62	24,000	2.50	8.2
	EHD2X48A**	*8MPV075	TDR&TXV	41,000	0.75	10.80	13.00		41,000	3.50	24,600	2.42	8.0
	EHD2X48A**	*8MPV100	TDR&TXV	41,000	0.75	11.20	13.50		40,500	3.56	24,400	2.48	8.2
	EHD2X48A**	*8MPV125	TDR&TXV	41,000	0.75	11.20	13.50		40,500	3.58	24,400	2.48	8.2
	EHD2X48A**	*9MPV100	TDR&TXV	41,000	0.75	11.00	13.20		40,500	3.52	24,600	2.44	8.2
	EHD2X48A**	*9MPV125	TDR&TXV	41,000	0.75	11.00	13.20		40,500	3.54	24,400	2.46	8.2
	EHD2X48A**	*9MVX080	TDR&TXV	41,000	0.75	10.80	13.20		40,500	3.52	24,600	2.44	8.2
	EHD2X48A**	*9MVX100	TDR&TXV	41,000	0.75	11.00	13.20		40,500	3.54	24,400	2.46	8.2
	EHD2X48A**	MV12F19**B*	TDR&TXV	41,000	0.75	11.20	13.50		40,500	3.60	24,200	2.50	8.2
	EHD2X48A**	MV16J22**B*	TDR&TXV	41,000	0.75	11.20	13.50		40,500	3.62	24,200	2.50	8.2
EHD2X48A**	MV20L24**B*	TDR&TXV	41,000	0.75	11.20	13.50		40,500	3.62	24,200	2.50	8.2	
FEM2X48****	†	TDR&TXV	42,000	0.75	11.20	13.50		38,000	3.46	24,600	2.48	8.2	
FVM2X36****	†	TDR&TXV	39,500	0.75	11.00	13.20		42,000	3.42	24,000	2.40	7.8	
FVM2X48****	†	TDR&TXV	41,500	0.75	11.20	13.50		37,200	3.40	24,200	2.50	8.1	
N2H348*HB N2H348*LB	‡FEM2X48****	†	TDR&TXV	46,500	0.75	10.80	13.00		47,000	3.56	30,000	2.58	8.0
	EB*2X48J**	*8MPV100	TDR&TXV	45,500	0.75	10.80	13.00		47,000	3.44	29,800	2.54	7.7
	EB*2X48J**	*8MPV125	TDR&TXV	45,500	0.75	10.80	13.00		47,000	3.46	29,800	2.54	7.8
	EB*2X48J**	MV16J22**B*	TDR&TXV	45,500	0.75	11.00	13.20		46,500	3.48	29,200	2.58	7.8

ENERGY STAR compliance for combinations with: SEER 13.00 or higher and HSPF 7.7 or higher. (3-phase)

† For coils not listed with a matching furnace or blower, coil rating applies with any indoor blower device.

- continued on next page -

COOLING & HEATING PERFORMANCE FOR COMBINATION RATINGS (continued)
Indoor Models

Outdoor Model	Current Indoor Model (‡ tested combo)	Furnace Model	Factory Installed	Cool 95° F (35° C)			SEER		Heat 47° F (8.3° C)		Heat 17° F (-8.3° C)		HSPF
				BTU/hr	S / T	EER	factory	with field TDR	BTU/hr	COP	BTU/hr	COP	
N2H348*HB N2H348*LB (continued)	EB*2X48L**	*9MPV125	TDR&TXV	45,500	0.75	10.80	13.00		47,000	3.42	29,800	2.52	7.7
	EB*2X48L**	MV20L24**B*	TDR&TXV	45,500	0.75	11.00	13.20		46,500	3.48	29,200	2.60	7.8
	EB*2X60J**	*8MPV100	TDR&TXV	47,000	0.75	11.00	13.20		42,500	3.32	30,000	2.58	7.8
	EB*2X60J**	*8MPV125	TDR&TXV	47,000	0.75	11.20	13.50		42,500	3.34	29,800	2.58	7.8
	EB*2X60J**	*9MPV100	TDR&TXV	46,500	0.75	10.80	13.00		43,000	3.30	30,000	2.54	7.7
	EB*2X60J**	MV16J22**B*	TDR&TXV	47,000	0.75	11.20	13.50		43,000	3.44	29,200	2.62	8.0
	EB*2X60L**	*9MPV125	TDR&TXV	46,500	0.75	11.00	13.20		43,500	3.34	30,000	2.54	7.8
	EB*2X60L**	*9MVX100	TDR&TXV	46,500	0.75	11.00	13.20		43,000	3.32	29,800	2.54	7.7
	EB*2X60L**	MV20L24**B*	TDR&TXV	47,000	0.75	11.20	13.50		43,000	3.42	29,200	2.62	8.0
	ED*2X48J**	*8MPV100	TDR&TXV	45,500	0.75	10.80	13.00		47,000	3.44	29,800	2.54	7.7
	ED*2X48J**	*8MPV125	TDR&TXV	45,500	0.75	10.80	13.00		47,000	3.46	29,800	2.54	7.8
	ED*2X48J**	MV16J22**B*	TDR&TXV	45,500	0.75	11.20	13.50		46,500	3.48	29,200	2.58	7.8
	ED*2X48L**	*9MPV125	TDR&TXV	45,500	0.75	10.80	13.00		47,000	3.42	29,800	2.52	7.7
	ED*2X48L**	MV20L24**B*	TDR&TXV	45,500	0.75	11.00	13.50		46,500	3.48	29,200	2.60	7.8
	ED*2X60J**	*8MPV100	TDR&TXV	47,000	0.75	11.00	13.20		42,500	3.32	30,000	2.58	7.8
	ED*2X60J**	*8MPV125	TDR&TXV	47,000	0.75	11.20	13.50		42,500	3.34	29,800	2.58	7.8
	ED*2X60J**	*9MPV100	TDR&TXV	46,500	0.75	10.80	13.35		43,000	3.30	30,000	2.54	7.7
	ED*2X60J**	MV16J22**B*	TDR&TXV	47,000	0.75	11.20	13.50		43,000	3.44	29,200	2.62	8.0
	ED*2X60L**	*9MPV125	TDR&TXV	46,500	0.75	11.00	13.20		43,500	3.34	30,000	2.54	7.8
	ED*2X60L**	*9MVX100	TDR&TXV	46,500	0.75	11.00	13.20		43,000	3.32	29,800	2.54	7.7
	ED*2X60L**	MV20L24**B*	TDR&TXV	47,000	0.75	11.20	13.50		43,000	3.42	29,200	2.62	8.0
	EHD2X48A**	*8MPV100	TDR&TXV	46,000	0.75	10.80	13.00		47,000	3.46	29,800	2.54	7.8
	EHD2X48A**	*8MPV125	TDR&TXV	46,000	0.75	11.00	13.20		47,000	3.46	29,800	2.56	7.8
	EHD2X48A**	*9MPV125	TDR&TXV	46,000	0.75	10.80	13.00		47,000	3.42	29,800	2.52	7.7
	EHD2X48A**	MV16J22**B*	TDR&TXV	46,000	0.75	11.20	13.50		46,500	3.50	29,400	2.60	7.8
	EHD2X48A**	MV20L24**B*	TDR&TXV	46,000	0.75	11.20	13.50		46,500	3.50	29,400	2.60	7.8
	EHD2X60A**	*8MPV100	TDR&TXV	47,500	0.75	11.20	13.50		45,500	3.50	30,000	2.58	8.0
	EHD2X60A**	*8MPV125	TDR&TXV	47,500	0.75	11.20	13.50		45,500	3.52	29,800	2.60	8.0
	EHD2X60A**	*9MPV100	TDR&TXV	47,000	0.75	11.00	13.20		46,000	3.46	30,200	2.56	7.8
	EHD2X60A**	*9MPV125	TDR&TXV	47,000	0.75	11.00	13.20		46,000	3.48	30,000	2.56	8.0
EHD2X60A**	*9MVX080	TDR&TXV	47,000	0.75	11.00	13.20		45,500	3.44	30,200	2.56	7.8	

ENERGY STAR compliance for combinations with: SEER 13.00 or higher and HSPF 7.7 or higher. (3-phase)

† For coils not listed with a matching furnace or blower, coil rating applies with any indoor blower device.

- continued on next page -

COOLING & HEATING PERFORMANCE FOR COMBINATION RATINGS (continued)
Indoor Models

Outdoor Model	Current Indoor Model (‡ tested combo)	Furnace Model	Factory Installed	Cool 95° F (35° C)			SEER		Heat 47° F (8.3° C)		Heat 17° F (-8.3° C)		HSPF
				BTU/hr	S / T	EER	factory	with field TDR	BTU/hr	COP	BTU/hr	COP	
N2H348*HB N2H348*LB (continued)	EHD2X60A**	*9MVX100	TDR&TXV	47,000	0.75	11.00	13.20		46,000	3.46	29,800	2.56	7.8
	EHD2X60A**	MV16J22**B*	TDR&TXV	47,000	0.75	12.00	14.00		45,500	3.58	29,200	2.64	8.0
	EHD2X60A**	MV20L24**B*	TDR&TXV	47,000	0.75	12.00	14.00		45,500	3.58	29,200	2.64	8.0
	FEM2X60****	†	TDR&TXV	48,000	0.75	11.20	13.50		41,500	3.38	30,000	2.62	8.0
	FVM2X48****	†	TDR&TXV	46,500	0.75	11.20	13.50		46,000	3.50	29,400	2.58	7.9
	FVM2X60****	†	TDR&TXV	47,500	0.75	12.00	14.00		45,000	3.56	29,200	2.64	8.1
N2H360*HC N2H360*LC	‡FEM2X60****	†	TDR&TXV	56,000	0.78	11.00	13.00		56,000	3.60	35,000	2.54	7.9
	EB*2X60J**	MV16J22**B*	TDR&TXV	55,500	0.78	11.00	13.00		55,500	3.54	34,200	2.52	7.8
	EB*2X60L**	MV20L24**B*	TDR&TXV	55,500	0.78	11.00	13.00		55,500	3.54	34,400	2.52	7.8
	ED*2X60J**	MV16J22**B*	TDR&TXV	55,500	0.78	11.00	13.00		55,500	3.54	34,200	2.52	7.8
	ED*2X60L**	MV20L24**B*	TDR&TXV	55,500	0.78	11.00	13.00		55,500	3.54	34,400	2.52	7.8
	EHD2X60A**	MV16J22**B*	TDR&TXV	55,500	0.78	11.00	13.00		56,500	3.64	34,200	2.54	7.9
	EHD2X60A**	MV20L24**B*	TDR&TXV	55,500	0.78	11.00	13.00		56,500	3.64	34,200	2.54	7.9
FVM2X60****	†	TDR&TXV	55,500	0.78	11.00	13.00		56,000	3.62	34,400	2.54	7.9	

ENERGY STAR compliance for combinations with: SEER 13.00 or higher and HSPF 7.7 or higher. (3-phase)

† For coils not listed with a matching furnace or blower, coil rating applies with any indoor blower device.



This product has been designed and manufactured to meet ENERGY STAR criteria for energy efficiency when matched with appropriate coil components. However, proper refrigerant charge and proper air flow are critical to achieve rated capacity and efficiency. Installation of this product should follow the manufacturer's refrigerant charging and air flow instructions. Failure to confirm proper charge and airflow may reduce energy efficiency and shorten equipment life.

OUTDOOR UNIT MODEL NUMBER IDENTIFICATION GUIDE (3-phase)											
Digit Position:	1	2	3	4	5, 6	7	8	9	10	11	12
Example Part Number:	N	2	H	3	36	A	H	A	1	0	0
Product Family	BRANDING										
2 = R-22											
4 = R-410A	REFRIGERANT										
A = Air Conditioner											
H = Heat Pump			TYPE								
3 = 13 SEER			NOMINAL EFFICIENCY								
36 = 36,000 BTUH = 3 tons											
42 = 42,000 BTUH = 3½ tons											
48 = 48,000 BTUH = 4 tons											
60 = 60,000 BTUH = 5 tons					NOMINAL CAPACITY						
A = Standard Grille											
G = Coil Guard Grille							FEATURES				
H = 208/230-3-60											
L = 460-3-60							VOLTAGE				
Sales Code											
Engineering Revision											
Extra Digit											
Extra Digit											

ACCESSORIES PART NUMBER IDENTIFICATION GUIDE									
Digit Position:	1	2	3	4	5	6, 7	8, 9	10, 11	
Example Part Number:	N	A	S	A	0	01	01	CH	
N = Non-Branded	BRANDING								
A = Accessory	PRODUCT GROUP								
S = Split System (AC & HP)			KIT USAGE						
A = Original									
B = 2nd Generation			MAJOR SERIES						
0 = Generic or Not Applicable									
2 = R-22									
4 = R-410A					REFRIGERANT				
Product Identifier Number									
Package Quantity									
Type of Kit (Example: CH = Crankcase Heater)									