

### COMMERCIAL PACKAGED HEAT PUMP AIR HANDLER UNITS, 6 - 10 TONS

#### BUILT TO LAST, EASY TO INSTALL AND SERVICE

- Multi-position design for horizontal or vertical installation without modification.
- Two sloped condensate pans on each unit for horizontal or vertical applications.
- Cleanable insulation treated with Environmental Protection Agency (EPA) registered antimicrobial agent improves indoor air quality.
- 2 inch filters.
- High-static design meets a wide range of applications.
- Powerfull belt-driven forward curved fans.
- Single refrigerant circuit on 072 and 091 sizes. Dual refrigerant circuit on 120 sizes. Dual circuit can be field modified for use on single circuit condensers.
- Single blower on on all units
- Cooling coils with mechanically bonded fins provide peak heat transfer.
- Standard factory-installed thermo-static expansion valve (TXV) with removable power element.
- Easy maintenance - removal of single panel allows access to virtually all components.
- Die-formed galvanized steel casings provide durability and structural integrity. Optional paint is available.
- 24-volt terminal block for control wiring connection.
- Economizer accessory provides ventilation air and “free” cooling.
- Hot water coil, steam coil, and electric heat accessories are available.

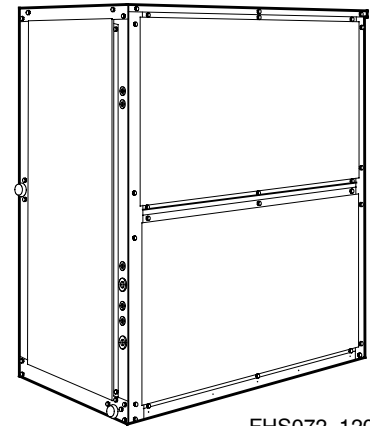

FHS072-120

#### WARRANTY

- 1 Year parts limited warranty



Use of the AHRI Certified TM Mark indicates a manufacturer's participation in the program. For verification of certification for individual products, go to [www.ahrirectory.org](http://www.ahrirectory.org).



UNIT PERFORMANCE DATA				
UNIT	Nominal Tons	Number of Circuits	Unit Dimensions H x W x L [mm]	Unit Weight lb. [kg]
FHS072*AAA0A0A	6	1	56-1/16" x 49" x 28-3/16" [1424 x 1244 x 714]	399 [181]
FHS091*AAA0A0A	7 <sup>1/2</sup>	1	56-1/16" x 49" x 28-3/16" [1424 x 1244 x 714]	404 [183]
FHS120*AAA0A0A	10	2	56-1/16" x 49" x 28-3/16" [1424 x 1244 x 714]	425 [193]

\* Indicates Unit voltage: K = 208/230-1-60, M = 208/230/460-3-60, S = 575-3-60

**NOTE: BASE MODEL NUMBERS LISTED. SEE MODEL NOMENCLATURE LISTING FOR ADDITIONAL OPTIONS**

# TABLE OF CONTENTS

.....	PAGE
MODEL NUMBER NOMENCLATURE .....	3
OPTIONS AND ACCESSORIES .....	4
PHYSICAL DATA .....	7
DIMENSIONS .....	8
PERFORMANCE DATA .....	13
ELECTRICAL DATA .....	17
TYPICAL PIPING AND WIRING .....	21
TYPICAL CONTROL WIRING SCHEMATIC .....	23
APPLICATION DATA .....	24
GUIDE SPECIFICATIONS .....	26

# MODEL NOMENCLATURE

MODEL SERIES	F	H	S	0	9	1	M	A	A	A	0	A	0	A
Position Number	1	2	3	4	5	6	7	8	9	10	11	12	13	14
F = R-410A Fan Coil Unit														
H = Heat Pump <span style="float: right;">Type</span>														
S = Standard Efficiency <span style="float: right;">Efficiency</span>														
072 = 6 Tons (1 circuit) 091 = 7.5 Tons (1 circuit) 120 = 10 Tons (2 circuit) <span style="float: right;">Nominal Cooling Capacity</span>														
K = 208/230-1-60 M = 460/208/230-3-60 S = 575-3-60 <span style="float: right;">VOLTAGE</span>														
A = Belt Drive, Standard Motor and Drive B = Belt Drive, High Static Motor and Drive <span style="float: right;">Fan Motor Options</span>														
A = Al/Copper <span style="float: right;">Indoor Coil</span>														
A = Standard D/X Coil <span style="float: right;">Refrigerant System</span>														
0 = No Options <span style="float: right;">Future Use</span>														
A = Unpainted - Standard B = Painted cabinet (Gray) <span style="float: right;">Painted Cabinet Options</span>														
0 = Standard (Future use) <span style="float: right;">Future Use</span>														
A = Original Design <span style="float: right;">Sales Digit</span>														

Single phase FHS072-091 units designate standard motor and high static drive.  
All FHS072-120 with a "M" voltage designation are triple voltage; i.e., 208/230/460-3-60.

MODEL NUMBERS	
Standard Static	High Static
FHS072KAAA0A0A	FHS072KBAA0A0A
FHS072MAAA0A0A	FHS072MBAA0A0A
FHS072SAAA0A0A	FHS072SBAA0A0A
FHS091KAAA0A0A	FHS091KBAA0A0A
FHS091MAAA0A0A	FHS091MBAA0A0A
FHS091SAAA0A0A	FHS091SBAA0A0A
FHS120MAAA0A0A	FHS120MBAA0A0A
FHS120SAAA0A0A	FHS120SBAA0A0A

## FACTORY OPTIONS AND/OR ACCESSORIES

**Alternate fan motors and drives** are available to provide the widest possible range of performance.

**Prepainted steel units** are available from the factory for applications that require painted units. Units are painted with American Sterling Gray color.

### Field-installed accessories

**Two-row hot water coils** have copper tubes mechanically bonded to aluminum plate fins and non-ferrous headers.

**One-row steam coil** has copper tubes and aluminum fins. The Inner Distributing Tube (IDT) design provides uniform temperatures across the coil face. The steam coil has a broad operating pressure range; up to 20 psi (138 kPag) at 260°F (126°C). The IDT steam coils are especially suited to applications where sub-freezing air enters the unit.

**Electric resistance heat coils** have an open-wire design and are mounted in a rigid frame. Safety cutouts for high temperature conditions are standard. Terminal block for single-point power connection is included.

**Economizer (enthalpy controlled)** provides ventilation air and “free” cooling if outside ambient temperature and humidity are suitable. It can also be used with CO<sub>2</sub> sensors to help meet indoor air quality requirements.

**Discharge plenum** directs the air discharge directly into the occupied space; integral horizontal and vertical louvers enable redirection of airflow. Accessory is available unpainted or painted. Field assembly is required (only applicable for vertical application and cannot be used with electric heat).

**Return-air grille** provides a protective barrier over the return-air opening and gives a finished appearance to units installed in the occupied space. Accessory is available unpainted or painted.

**Subbase** provides a stable, raised platform and room for condensate drain trap connection for vertical floor-mounted units. Accessory is available unpainted or painted.

**Overhead suspension package** includes necessary brackets to support units in horizontal ceiling installations.

**CO<sub>2</sub> sensors** can be used in conjunction with the economizer accessory to help meet indoor air quality requirements. The sensor signals the economizer to open when the CO<sub>2</sub> level in the space exceeds the set point. A programmable thermostat can be used to override the sensor if the outside-air temperature is too high or too low.

**Condensate drain trap** includes an overflow shutoff switch that can be wired to turn off the unit if the trap becomes plugged. Kit also includes a wire harness that can be connected to an alarm if desired. The transparent trap is designed for easy service and maintenance.

ITEM	OPTION*	ACCESSORY †
High Static Fan Motor / Drives	X	
CO <sub>2</sub> Sensors		X
Condensate Drain Trap		X
Discharge Plenum		X
Economizer		X
Electric Heat		X
Hot Water Heating Coils		X
Overhead Suspension Package		X
Prepainted Units	X	
Return Air Grille		X
Steam Heating Coil		X
Subbase		X

\* Factory-installed option.

† Field-installed accessory

ACCESSORIES		
Model Number	Description	Used on Unit Size (Tons)
AGRC01AA	Return Air Grille	6 to 10
AGRPC01AA	Return Air Grille, Painted	6 to 10
ASPC01AA	Steam Coil (1 Row)	6 to 10
ASBC01A	Floor Mount Base (Subbase)	6 to 10
ASBPC01A	Floor Mount Base (Subbase), Painted	6 to 10
AHBC01A	Overhead Suspension Brackets	6 to 10
ACSC01A	Condensate Overflow Switch	6 to 10
APDC01AA	Discharge Plenum	6 to 10
APDPC01AA	Discharge Plenum, Painted	6 to 10
DNCBDIOX005A00	CO <sub>2</sub> Sensor for Economizer	6 to 10
AEMC01AA	Economizer	6 to 10
AHWC01AA	Hot Water Coil (2 Row)	6 to 10

**ACCESSORY HEATERS**

<b>HEATER PART NO.</b>	<b>DESCRIPTION</b>	<b>Nominal Capacity</b>	<b>Used With</b>
AAHC05AHA	5.0 kW, 240-3-60	5	072, 091, 120
AAHC10AHA	10.0 kW, 240-3-60	10	072, 091, 120
AAHC15AHA	15.0 kW, 240-3-60	15	072, 091, 120
AAHC25AHA	25.0 kW, 240-3-60	25	072, 091, 120
AAHC35AHA	35.0 kW, 240-3-60	35	091, 120
AAHC05ALA	5.0 kW, 480-3-60	5	072, 091, 120
AAHC10ALA	10.0 kW, 480-3-60	10	072, 091, 120
AAHC15ALA	15.0 kW, 480-3-60	15	072, 091, 120
AAHC25ALA	25.0 kW, 480-3-60	25	072, 091, 120
AAHC35ALA	35.0 kW, 480-3-60	35	091, 120
AAHC05ASA	5.0 kW, 575-3-60	5	072, 091, 120
AAHC10ASA	10.0 kW, 575-3-60	10	072, 091, 120
AAHC15ASA	15.0 kW, 575-3-60	15	072, 091, 120
AAHC25ASA	25.0 kW, 575-3-60	25	072, 091, 120
AAHC35ASA	35.0 kW, 575-3-60	35	091, 120

FAS WITH DISCHARGE PLENUM, RETURN AIR GRILLE AND SUBBASE

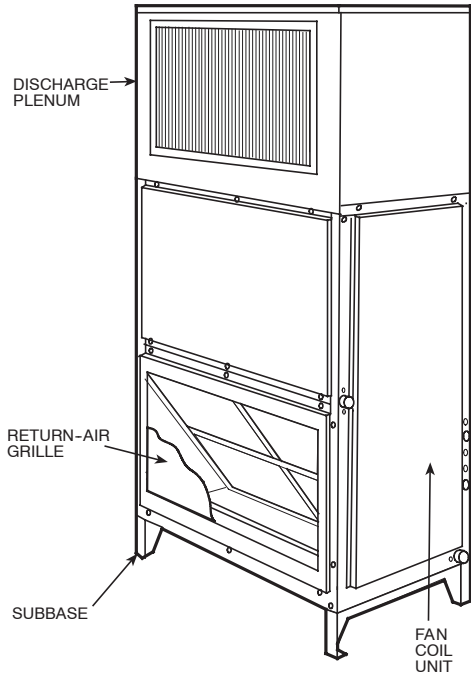

FAS WITH HOT WATER OR STEAM COIL

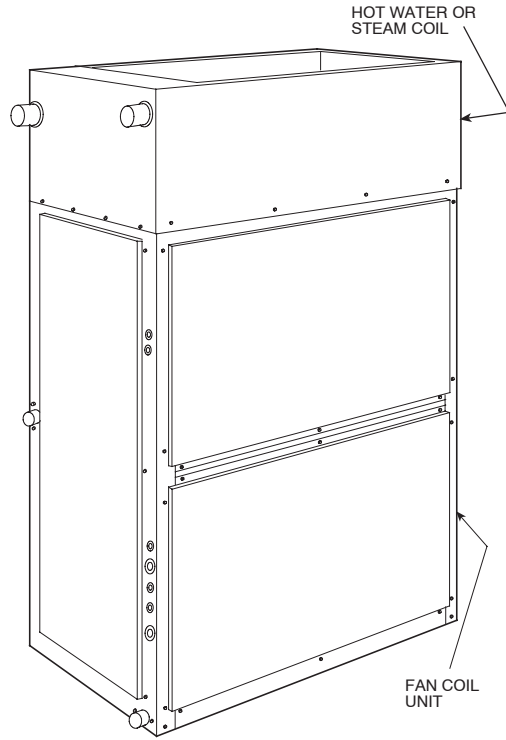

FAS WITH ECONOMIZER

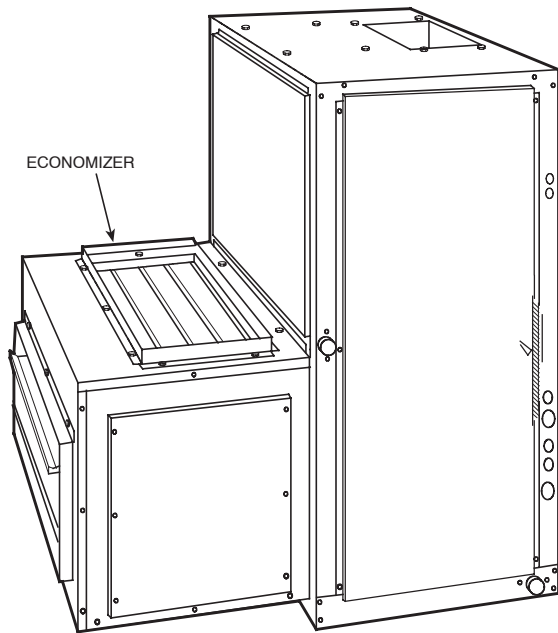

FAS WITH CONDENSATE TRAP

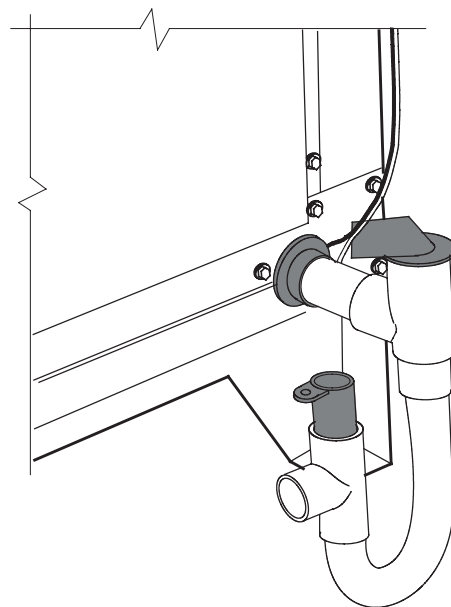

<b>Physical Data</b>			
<b>UNIT FHS</b>	<b>072</b>	<b>091</b>	<b>120</b>
NOMINAL CAPACITY (Tons)	6	7 <sup>1</sup> / <sub>2</sub>	10
<b>FANS</b>			
Qty...Diam. (in.)	1...15	1...15	1...15
Nominal Airflow (cfm)	2400	3000	4000
Airflow Range (cfm)	1800-3000	2250-3750	3000-5000
Nominal Motor Hp (Standard Motor)*			
208/230-1-60	2.4	2.4	—
208/230-3-60 and 460-3-60	2.4	2.4	2.4
575-3-60	2.0	2.0	2.0
Motor Speed (rpm)			
208/230-1-60	1725	1725	—
208/230-3-60 and 460-3-60	1725	1725	1725
575-3-60	1725	1725	1725
<b>REFRIGERANT SYSTEM</b>			
# Circuit Splits	1	1	2
Split type .....percentage	—	—	Face ...50/50
Shipping charge A/B (lbs)	Nitrogen purge	Nitrogen purge	Nitrogen purge
Metering Device	TXV	TXV	TXV
<b>DIRECT-EXPANSION COIL</b>			
	Enhanced Copper Tubes, Aluminum Sine-Wave Fins		
Max Working Pressure (psig)	650		
Material - tube / fin	Al / Cu	Al / Cu	Al / Cu
Coil Type	RTPF		
Face Area (sq ft)	8.3	8.3	10.0
No. of Splits	1	1	2
Split Type...Percentage	—	—	Face...50/50
No. of Circuits per Split	15	15	9
Rows...Fins/in.	3 / 15	4 / 15	4 / 15
<b>STEAM COIL</b>			
Max Working Pressure (psig at 260 F)	20	20	
Total Face Area (sq ft)	6.67	6.67	6.67
Rows...Fins/in.	1...9	1...9	1...9
<b>HOT WATER COIL</b>			
Max Working Pressure (psig)	150	150	
Total Face Area (sq ft)	6.67	6.67	6.67
Rows...Fins/in.	2...8.5	2...8.5	2...8.5
Water Volume			
(gal)	8.3	8.3	
(ft <sup>3</sup> )	1.1	1.1	
<b>PIPING CONNECTIONS</b>			
Quantity...Size (in.)			
DX Coil — Suction (ODF)	1...1 <sup>1</sup> / <sub>8</sub>	1...1 <sup>1</sup> / <sub>8</sub>	2...1 <sup>1</sup> / <sub>8</sub>
DX Coil — Liquid Refrigerant (ODF)	1... <sup>5</sup> / <sub>8</sub>	1... <sup>5</sup> / <sub>8</sub>	2... <sup>5</sup> / <sub>8</sub>
Steam Coil, In (MPT)	1...2 <sup>1</sup> / <sub>2</sub>	1...2 <sup>1</sup> / <sub>2</sub>	1...2 <sup>1</sup> / <sub>2</sub>
Steam Coil, Out (MPT)	1...1 <sup>1</sup> / <sub>2</sub>	1...1 <sup>1</sup> / <sub>2</sub>	1...1 <sup>1</sup> / <sub>2</sub>
Hot Water Coil, In (MPT)	1...1 <sup>1</sup> / <sub>2</sub>	1...1 <sup>1</sup> / <sub>2</sub>	1...1 <sup>1</sup> / <sub>2</sub>
Hot Water Coil, Out (MPT)	1...1 <sup>1</sup> / <sub>2</sub>	1...1 <sup>1</sup> / <sub>2</sub>	1...1 <sup>1</sup> / <sub>2</sub>
Condensate (PVC)	1...1 <sup>1</sup> / <sub>4</sub> ODM/1 IDF		
<b>FILTERS</b>			
	Throwaway — Factory-Supplied		
Quantity...Size (in.)	4...16 x 24 x 2		
Access Location	Right or Left Side		

\* Refer to Alternate Fan Motor Data table for alternate motor data.

# Dimensions - FHS072-120

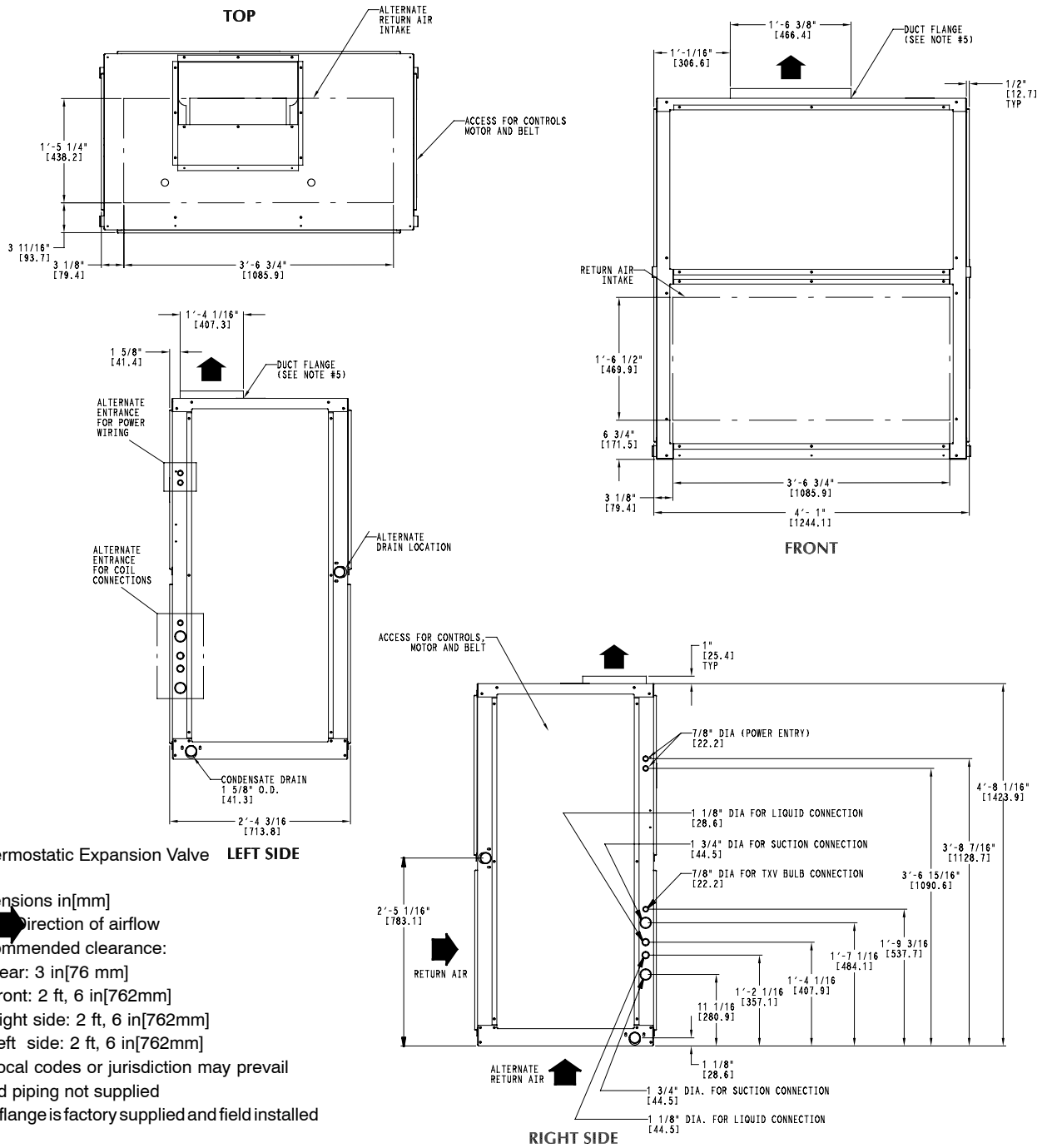

**LEGEND**

TXV - Thermostatic Expansion Valve

**NOTES:**

1. Dimensions in [mm]
2. Direction of airflow
3. Recommended clearance:
  - Rear: 3 in [76 mm]
  - Front: 2 ft, 6 in [762mm]
  - Right side: 2 ft, 6 in [762mm]
  - Left side: 2 ft, 6 in [762mm]
  - Local codes or jurisdiction may prevail
4. Liquid piping not supplied
5. Duct flange is factory supplied and field installed

UNIT	UNIT WEIGHT lb(kg)
FHS072	381 (173)
FHS091	385 (175)
FHS120	427 (194)



## CORNER WEIGHTS HORIZONTAL POSITION

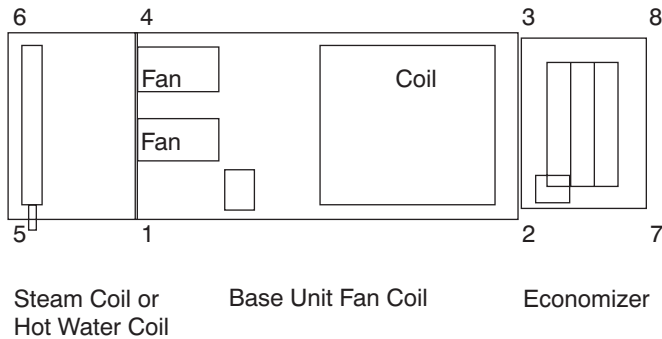

FHS UNIT SIZE	UNIT OR ACCESSORY NAME		UNIT OR ACCESSORY WEIGHT (lb)	CORNER NUMBER (WEIGHT IN LB)							
				1	2	3	4	5	6	7	8
072, 091, 120	FAN COIL BASE UNIT		394	108.0	104.7	89.4	92.2	—	—	—	—
	STEAM COIL	ADD	137	25.6	0.0	0.0	25.9	42.4	43.0	0.0	0.0
	HOT WATER COIL	ADD	143	26.3	0.0	0.0	26.9	44.3	45.5	0.0	0.0
	ECONOMIZER	ADD	128	0.0	25.5	24.7	0.0	0.0	0.0	39.3	38.1
	ECO + STEAM COIL	ADD	264	25.6	25.5	24.7	25.9	42.4	43.0	39.3	38.1
	ECO + HW COIL	ADD	271	26.3	25.5	24.7	26.9	44.3	45.5	39.3	38.1

## CORNER WEIGHTS VERTICAL POSITION

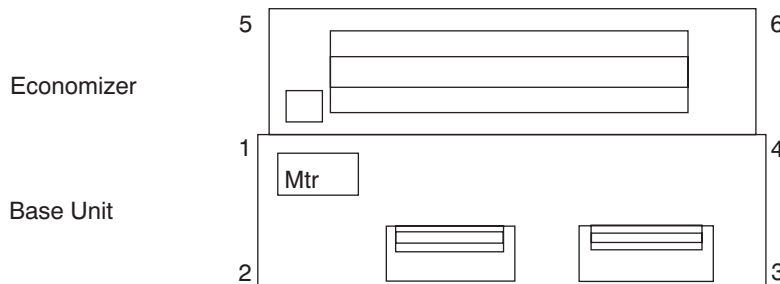

NOTE: Steam, Hot Water & Plenum on top of positions 1,2,3,4

FHS UNIT SIZE	UNIT OR ACCESSORY NAME		UNIT OR ACCESSORY WEIGHT (lb)	CORNER NUMBER (WEIGHT IN LB)					
				1	2	3	4	5	6
072, 091, 120	FAN COIL BASE UNIT		394	99.3	113.5	96.8	84.7	—	—
	STEAM COIL	ADD	137	34.5	34.5	34.0	34.0	0.0	0.0
	HOT WATER COIL	ADD	143	36.2	36.2	35.3	35.3	0.0	0.0
	PLENUM	ADD	175	50.8	36.7	36.7	50.8	0.0	0.0
	ECONOMIZER	ADD	128	25.5	0.0	0.0	24.7	39.3	38.1
	ECO + STEAM COIL	ADD	264	59.9	34.5	34.0	58.7	39.3	38.1
	ECO + HW COIL	ADD	271	61.7	36.2	35.3	60.0	39.3	38.1

**Dimensions (cont.)**

**Preferred Suspension Technique - Overhead Suspension Accessory**

**UNIT SIZES FHS072-120  
(FRONT)**

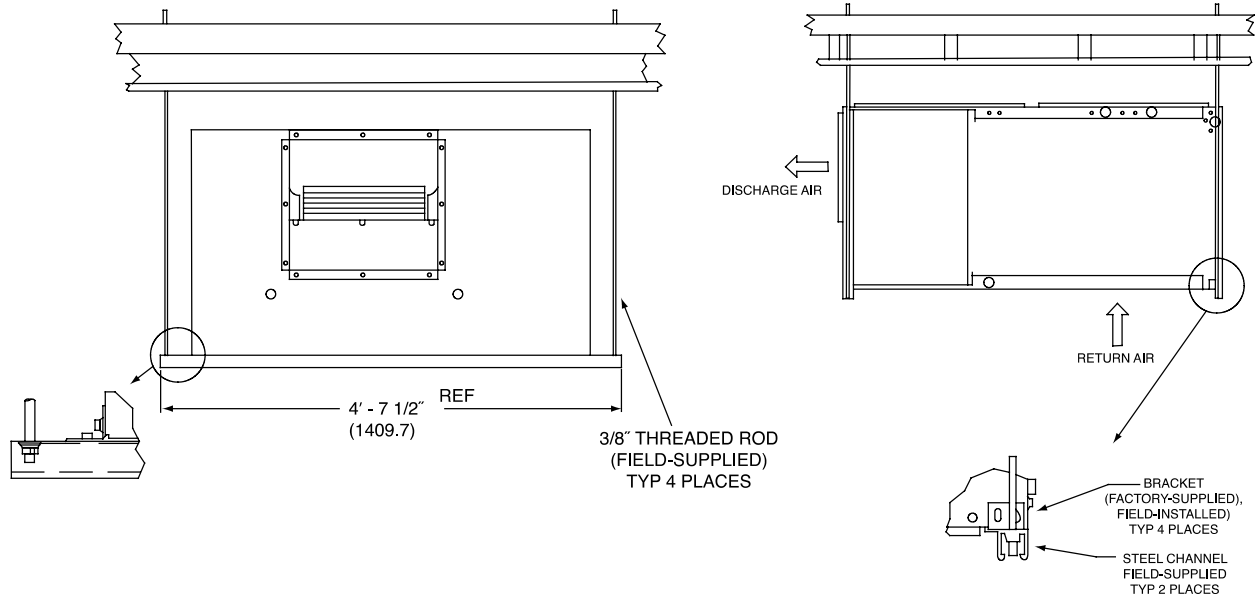

**PLENUM, RETURN-AIR GRILLE, AND SUBBASE ACCESSORIES  
UNIT SIZES 072 - 120**

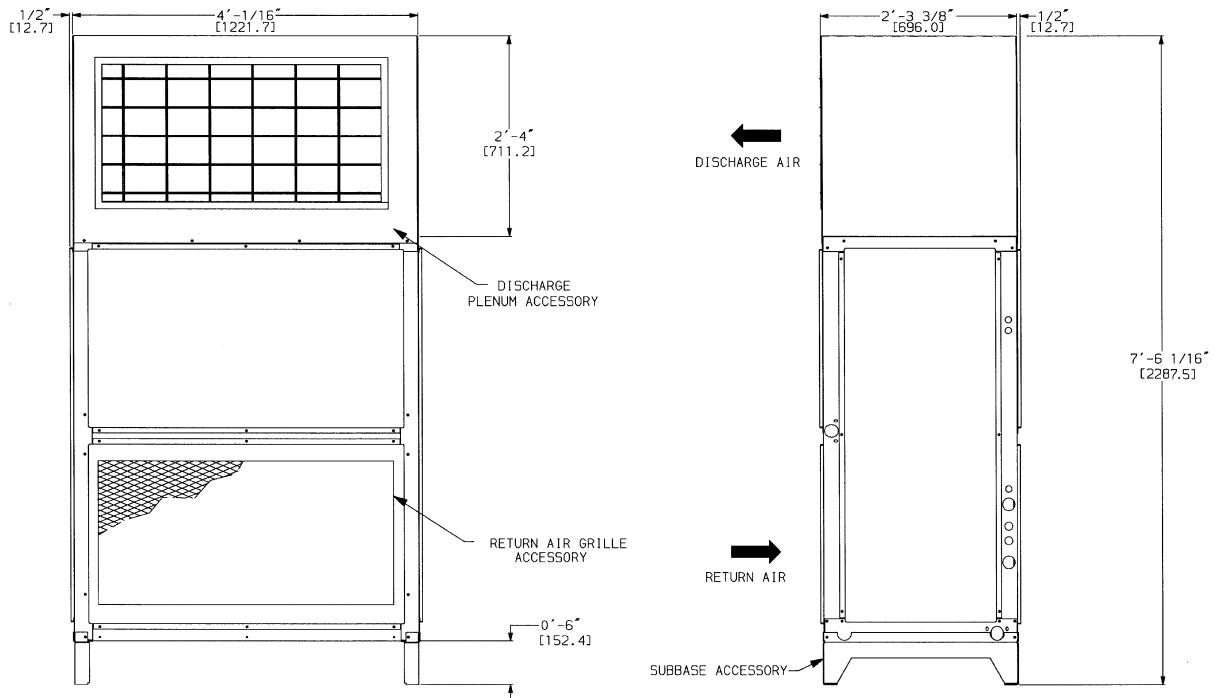

NOTE: Dimensions in [ ] are millimeters.

HOT WATER AND STEAM COIL ACCESSORIES

UNIT SIZES 072 - 120

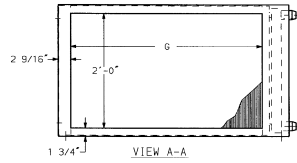
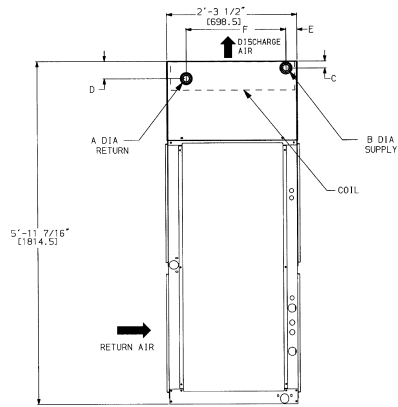
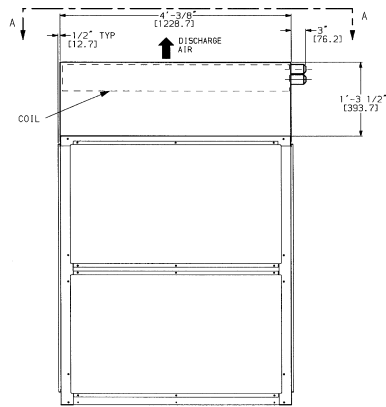

Dimension	Hot Water Coil	Steam Coil
A	1-1/2" MPT [38.1]	1-1/2" MPT [38.1]
B	1-1/2" MPT [38.1]	2-1/2" MPT [63.5]
C	2-3/8" [60.3]	3-1/8" [79.4]
D	4-7/8" [123.8]	3-1/8" [79.4]
E	2-1/8" [54.0]	4-9/16" [115.8]
F	1'-11 1/4" [590.6]	1' 9" [584.2]
G	3' 4" [1016.0]	3' 4" [1016.0]

NOTE: Dimensions in [ ] are millimeters.

**ECONOMIZER ACCESSORY**  
UNIT SIZES 072 - 120

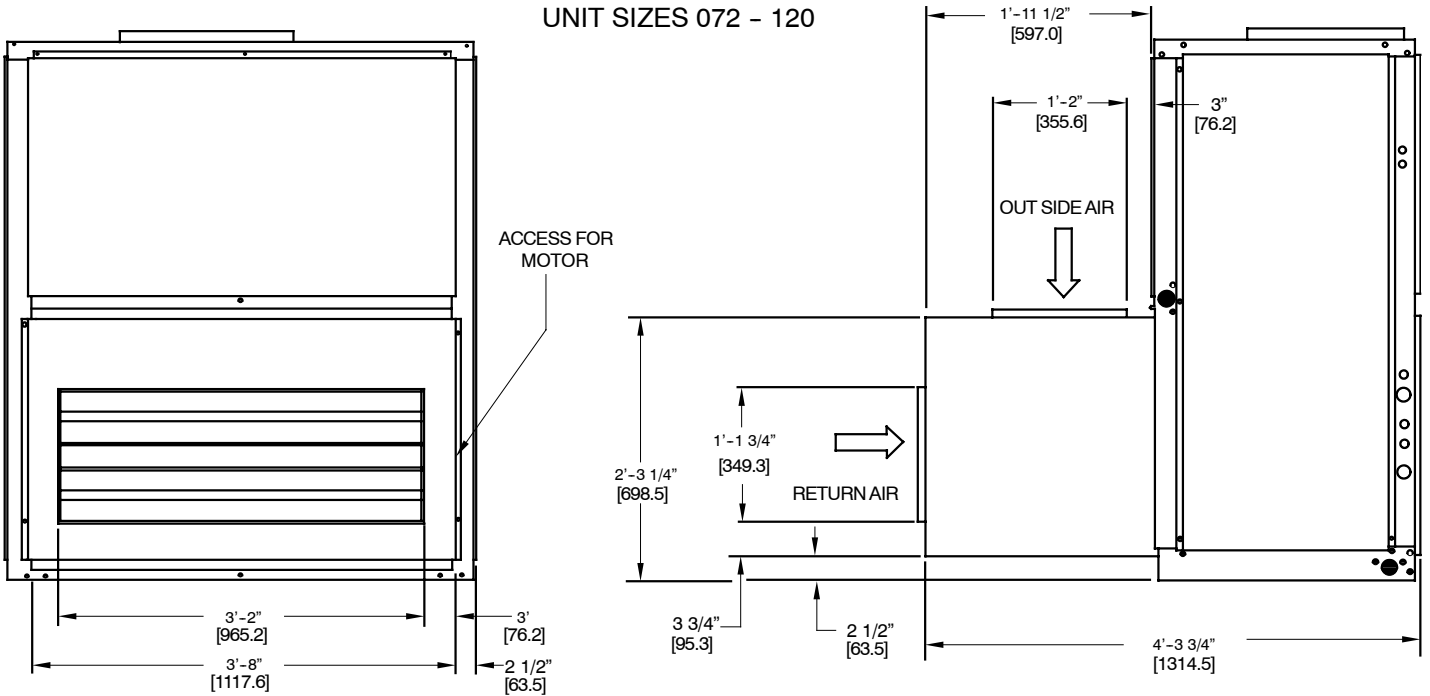

NOTE:

1. For horizontal unit applications, economizer can be attached to end of unit opposite duct connections.
2. Dimensions in [ ] are millimeters.

**ELECTRIC HEAT ACCESSORY**

UNIT SIZES 072 - 120

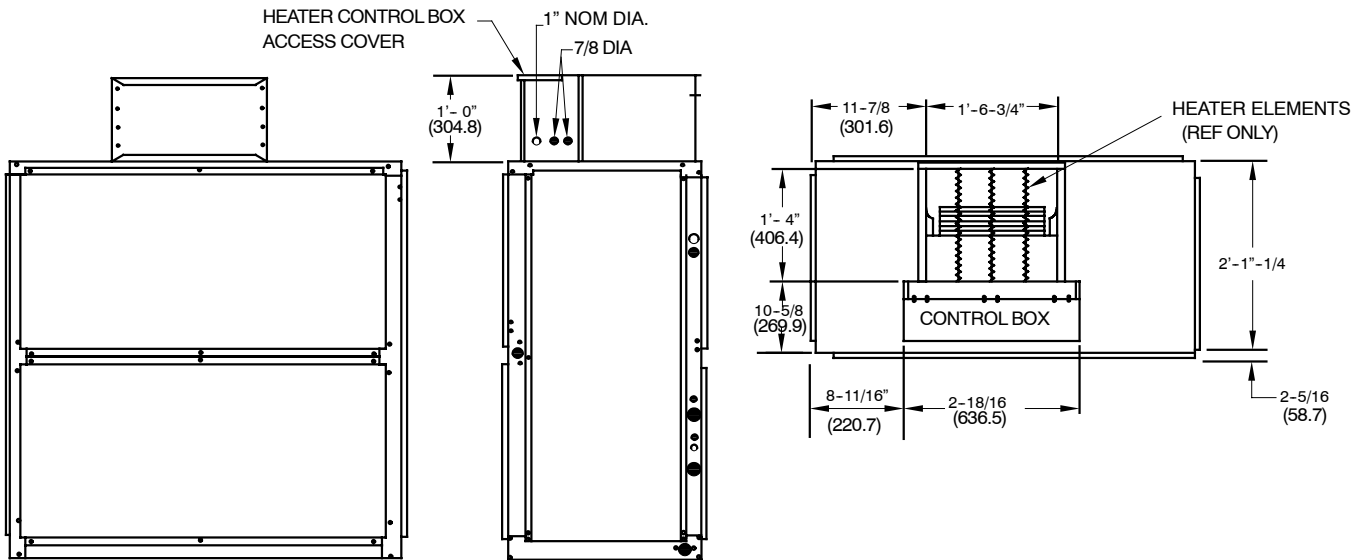

Note:

1. For horizontal unit applications, economizer can be attached to end of unit opposite duct connections.
2. Dimensions in [ ] millimeters.

# PERFORMANCE DATA

## COOLING ONLY PERFORMANCE

UNIT FHS	EVAPORATOR AIR		COIL REFRIGERANT TEMP (F)									
	AIR FLOW (CFM)	EWB (F)	30		35		40		45		50	
			TC	SHC	TC	SHC	TC	SHC	TC	SHC	TC	SHC
072	1800	72	146.4	71.0	132.1	64.3	116.7	57.3	100.0	49.7	81.8	42.0
		67	121.8	74.0	107.6	66.4	92.4	58.9	76.0	51.2	58.3	43.6
		62	99.3	75.5	85.3	67.9	70.2	60.2	54.9	52.4	44.2	44.2
	2400	72	179.3	87.1	161.7	79.1	142.6	70.4	122.0	61.2	99.5	51.8
		67	149.5	91.5	132.2	82.4	113.3	73.2	93.0	63.8	71.0	54.4
		62	122.3	94.2	105.0	84.9	86.2	75.5	67.6	65.7	55.2	55.2
	3000	72	207.4	101.3	186.8	92.0	164.6	81.7	140.6	71.2	114.6	60.4
		67	173.3	106.7	153.1	96.4	131.2	85.8	107.5	75.1	81.9	64.3
		62	142.1	110.8	122.0	100.2	100.0	89.3	78.2	78.2	65.2	65.2

FHS072 (3 Row Coil 30 X 40 inches - 8.33 ft<sup>2</sup> Face Area)

UNIT FHS	EVAPORATOR AIR		COIL REFRIGERANT TEMP (F)									
	AIR FLOW (CFM)	EWB (F)	30		35		40		45		50	
			TC	SHC	TC	SHC	TC	SHC	TC	SHC	TC	SHC
091	2250	72	182.6	88.6	165.5	132.0	146.7	95.2	126.3	64.2	104.0	104.0
		67	152.4	92.7	135.4	83.7	116.9	74.6	96.6	65.2	74.6	55.7
		62	124.9	95.2	107.8	86.0	89.3	76.6	70.2	67.0	56.7	56.7
	3000	72	221.4	107.7	200.6	98.2	177.7	87.8	152.8	76.8	125.7	65.6
		67	185.4	113.8	164.7	103.1	142.1	92.1	117.4	80.9	90.5	69.5
		62	152.4	118.1	131.6	107.2	109.0	95.8	86.2	83.9	70.9	70.9
	3750	72	253.9	124.2	229.9	113.3	203.8	101.4	175.1	89.0	143.9	76.3
		67	213.4	132.1	189.5	120.1	163.4	107.7	135.0	95.0	104.0	82.0
		62	175.8	138.6	151.9	126.1	125.8	113.1	99.4	99.4	83.3	83.3

FHS091 (4 Row Coil 30 X 40 inches - 8.33 ft<sup>2</sup> Face Area)

UNIT FHS	EVAPORATOR AIR		COIL REFRIGERANT TEMP (F)									
	AIR FLOW (CFM)	EWB (F)	30		35		40		45		50	
			TC	SHC	TC	SHC	TC	SHC	TC	SHC	TC	SHC
120	3000	72	221.4	107.7	200.6	163.3	177.7	117.8	152.8	79.1	125.7	125.7
		67	185.4	113.8	164.7	103.1	142.1	92.1	117.4	80.9	90.5	69.5
		62	152.4	118.1	131.6	107.2	109.0	95.8	86.2	83.9	70.9	70.9
	4000	72	263.7	129.4	238.7	117.9	211.6	105.6	181.9	92.8	149.4	79.6
		67	221.7	137.8	197.0	125.4	169.9	112.6	140.3	99.4	108.1	85.9
		62	182.9	144.9	158.0	132.1	130.8	118.5	104.0	104.0	87.2	87.2
	5000	72	298.3	147.4	270.2	134.4	239.6	120.8	205.9	106.6	169.0	91.9
		67	251.7	158.5	223.7	144.8	193.0	130.6	159.4	115.9	122.9	100.7
		62	208.3	168.6	180.1	154.3	149.1	138.5	120.4	120.4	101.5	101.5

FHS120 (4 Row Coil 36 X 40 inches - 10 ft<sup>2</sup> Face Area)

### LEGEND

TC - Total Capacity Gross (Mbtuh)

SHC - Sensible Heat Gross (Mbtuh)

# PERFORMANCE DATA (cont.)

## HYDRONIC HEATING CAPACITIES

UNIT	AIRFLOW (Cfm)	1-ROW STEAM*		2-ROW HOT WATER COIL†			
		Cap.	Ldb	Cap.	Ldb	Water Flow (Gpm)	PD
FHS072	1,800	146	134	156.0	140	15.6	3.4
	2,400	173	126	183.0	131	18.3	4.3
	3,000	209	123	206.0	124	20.6	5.2
FHS091	2,250	168	129	174.0	133	17.4	4.0
	3,000	209	123	206.0	124	20.6	5.2
	3,750	240	117	238.0	118	23.8	6.5
FHS120	3,000	209	123	299.0	152	29.9	5.0
	4,000	243	115	275.0	124	27.5	6.6
	5,000	279	111	316.0	119	31.6	8.2

### LEGEND:

Cap. - Capacity (Btuh in thousands)

Ldb - Leaving Air Dry Bulb Temp (°F)

PD - Pressure Drop (ft water)

\* Based on 5 psig steam, 60°F entering-air temperature. All steam coils are non-freeze type.

† Based on 200°F entering water, 20°F water temperature drop, 60°F entering-air temperature.

### NOTES:

- Maximum operating limits for heating coils: 20 psig at 260°F.
- Leaving db = ent db (°F) +  $\frac{\text{Capacity (Btuh)}}{1.1 \times \text{cfm}}$
- See Heating Correction Factors table.

## HEATING CORRECTION FACTORS

HOT WATER COIL						
Water Temp Drop (°F)	Ent Water Temp (°F)	Entering-Air Temp (°F)				
		40	50	60	70	80
10	140	0.72	0.64	0.57	0.49	0.41
	160	0.89	0.81	0.74	0.66	0.58
	180	1.06	0.98	0.90	0.83	0.75
	200	1.22	1.15	1.07	1.00	0.92
	220	1.39	1.32	1.24	1.17	1.09
20	140	0.64	0.57	0.49	0.41	0.33
	160	0.81	0.74	0.66	0.58	0.51
	180	0.98	0.91	0.83	0.75	0.68
	200	1.15	1.08	1.00	0.93	0.85
	220	1.32	1.25	1.17	1.10	1.02
30	140	0.56	0.49	0.41	0.33	0.24
	160	0.74	0.66	0.58	0.51	0.43
	180	0.91	0.83	0.76	0.68	0.60
	200	1.08	1.00	0.93	0.85	0.78
	220	1.25	1.18	1.10	1.03	0.95

STEAM COIL					
Steam Pressure (psig)	Entering-Air Temp (°F)				
	40	50	60	70	80
0	1.06	0.98	0.91	0.85	0.78
2	1.09	1.02	0.95	0.89	0.82
5	1.13	1.06	1.00	0.93	0.87

### NOTE:

Multiply capacity given in the Hydronic Heating Capacities table by the correction factor for conditions at which unit is actually operating. Correct leaving-air temperature using formula in Note 2 of Hydronic Heating Capacities table.

# PERFORMANCE DATA (cont.)

## FAN PERFORMANCE DATA — FHS 0.0-1.2 in. wg ESP — 60 Hz

UNIT	AIRFLOW (Cfm)	EXTERNAL STATIC PRESSURE (in. wg)													
		0.0		0.2		0.4		0.6		0.8		1.0		1.2	
		Rpm	Bhp	Rpm	Bhp	Rpm	Bhp	Rpm	Bhp	Rpm	Bhp	Rpm	Bhp	Rpm	Bhp
FHS072	1,800	<b>399</b>	<b>0.19</b>	<b>454</b>	<b>0.24</b>	548	0.35	634	0.47	<u>713</u>	<u>0.60</u>	<u>785</u>	<u>0.74</u>	<u>850</u>	<u>0.89</u>
	2,100	<b>446</b>	<b>0.28</b>	497	0.34	583	0.46	660	0.59	<u>733</u>	<u>0.73</u>	<u>802</u>	<u>0.88</u>	<u>867</u>	<u>1.05</u>
	2,400	498	0.40	541	0.47	622	0.60	<u>693</u>	<u>0.74</u>	<u>760</u>	<u>0.89</u>	<u>824</u>	<u>1.05</u>	<u>885</u>	<u>1.22</u>
	2,700	544	0.55	588	0.63	663	0.78	<u>730</u>	<u>0.93</u>	<u>792</u>	<u>1.09</u>	<u>851</u>	<u>1.26</u>	<u>909</u>	<u>1.44</u>
	3,000	594	0.73	635	0.82	<u>707</u>	<u>0.99</u>	<u>770</u>	<u>1.15</u>	<u>828</u>	<u>1.32</u>	<u>883</u>	<u>1.50</u>	<u>937</u>	<u>1.69</u>
FHS091	2,250	<b>273</b>	<b>0.08</b>	<b>493</b>	<b>0.37</b>	580	0.49	656	0.62	727	0.76	<u>794</u>	<u>0.92</u>	<u>858</u>	<u>1.08</u>
	2,600	<b>322</b>	<b>0.15</b>	<b>540</b>	<b>0.52</b>	622	0.66	693	0.81	<u>757</u>	<u>0.96</u>	<u>819</u>	<u>1.12</u>	<u>878</u>	<u>1.29</u>
	3,000	552	0.65	595	0.73	673	0.91	740	1.07	<u>800</u>	<u>1.24</u>	<u>856</u>	<u>1.41</u>	<u>910</u>	<u>1.60</u>
	3,400	615	0.91	653	1.01	726	1.21	<u>789</u>	<u>1.40</u>	<u>846</u>	<u>1.59</u>	<u>899</u>	<u>1.78</u>	<u>950</u>	<u>1.97</u>
	3,750	671	1.20	706	1.31	<u>773</u>	<u>1.53</u>	<u>834</u>	<u>1.74</u>	<u>889</u>	<u>1.95</u>	<u>940</u>	<u>2.16</u>	<u>988</u>	<u>2.37</u>
FHS120	3,000	<b>421</b>	<b>0.35</b>	<b>592</b>	<b>0.73</b>	670	0.90	737	1.06	<u>797</u>	<u>1.23</u>	<u>854</u>	<u>1.41</u>	<u>908</u>	<u>1.59</u>
	3,500	<b>626</b>	<b>0.98</b>	<b>664</b>	<b>1.08</b>	735	1.28	798	1.48	<u>855</u>	<u>1.67</u>	<u>908</u>	<u>1.87</u>	<u>958</u>	<u>2.07</u>
	4,000	706	1.42	738	1.54	803	1.77	862	2.00	<u>917</u>	<u>2.23</u>	<u>967</u>	<u>2.45</u>	<u>1014</u>	<u>2.67</u>
	4,500	786	1.99	815	2.12	<u>873</u>	<u>2.39</u>	<u>929</u>	<u>2.65</u>	<u>980</u>	<u>2.90</u>	<u>1028</u>	<u>3.16</u>	<u>1073</u>	<u>3.41</u>
	5,000	<u>867</u>	<u>2.70</u>	<u>893</u>	<u>2.84</u>	<u>946</u>	<u>3.14</u>	<u>997</u>	<u>3.43</u>	<u>1046</u>	<u>3.72</u>	<u>1092</u>	<u>4.00</u>	<u>1135</u>	<u>4.28</u>

### LEGEND

ESP — External Static Pressure

**Bold** indicates field-supplied drive or motor is required.

Plain type indicates standard motor and standard drive.

Underline indicates a different motor and drive combination other than the standard motor and standard drive combination is required. Refer to fan motor and drive tables to complete selection.

## FAN PERFORMANCE DATA — FHS 1.4-2.4 in. wg ESP — 60 Hz

UNIT	AIRFLOW (Cfm)	EXTERNAL STATIC PRESSURE (in. wg)											
		1.4		1.6		1.8		2.0		2.2		2.4	
		Rpm	Bhp	Rpm	Bhp	Rpm	Bhp	Rpm	Bhp	Rpm	Bhp	Rpm	Bhp
FHS072	1,800	<u>910</u>	<u>1.04</u>	<u>965</u>	<u>1.20</u>	<u>1016</u>	<u>1.36</u>	<u>1065</u>	<u>1.52</u>	<u>1111</u>	<u>1.69</u>	<u>1155</u>	<u>1.86</u>
	2,100	<u>927</u>	<u>1.21</u>	<u>983</u>	<u>1.38</u>	<u>1035</u>	<u>1.56</u>	<u>1084</u>	<u>1.74</u>	<u>1131</u>	<u>1.92</u>	<u>1175</u>	<u>2.11</u>
	2,400	<u>944</u>	<u>1.41</u>	<u>999</u>	<u>1.59</u>	<u>1052</u>	<u>1.78</u>	<u>1101</u>	<u>1.98</u>	<u>1149</u>	<u>2.18</u>	<u>1193</u>	<u>2.38</u>
	2,700	<u>964</u>	<u>1.63</u>	<u>1018</u>	<u>1.82</u>	<u>1069</u>	<u>2.03</u>	<u>1118</u>	<u>2.24</u>	<u>1165</u>	<u>2.45</u>	—	—
	3,000	<u>989</u>	<u>1.89</u>	<u>1039</u>	<u>2.10</u>	<b>1089</b>	<b>2.31</b>	<b>1136</b>	<b>2.53</b>	<b>1183</b>	<b>2.76</b>	—	—
FHS091	2,250	<u>918</u>	<u>1.26</u>	<u>975</u>	<u>1.43</u>	<u>1029</u>	<u>1.62</u>	<u>1079</u>	<u>1.80</u>	<u>1126</u>	<u>1.99</u>	<u>1172</u>	<u>2.18</u>
	2,600	<u>936</u>	<u>1.48</u>	<u>991</u>	<u>1.67</u>	<u>1044</u>	<u>1.87</u>	<u>1094</u>	<u>2.07</u>	<u>1142</u>	<u>2.28</u>	<u>1188</u>	<u>2.49</u>
	3,000	<u>963</u>	<u>1.79</u>	<u>1014</u>	<u>1.99</u>	<u>1064</u>	<u>2.20</u>	<u>1113</u>	<u>2.42</u>	<u>1159</u>	<u>2.64</u>	—	—
	3,400	<u>998</u>	<u>2.18</u>	<u>1045</u>	<u>2.39</u>	<u>1092</u>	<u>2.61</u>	<u>1137</u>	<u>2.83</u>	<u>1182</u>	<u>3.07</u>	—	—
	3,750	<u>1034</u>	<u>2.58</u>	<u>1078</u>	<u>2.80</u>	<u>1122</u>	<u>3.03</u>	<u>1164</u>	<u>3.27</u>	—	—	—	—
FHS120	3,000	<u>961</u>	<u>1.78</u>	<u>1012</u>	<u>1.98</u>	<u>1062</u>	<u>2.19</u>	<u>1111</u>	<u>2.41</u>	<u>1158</u>	<u>2.64</u>	—	—
	3,500	<u>1005</u>	<u>2.27</u>	<u>1052</u>	<u>2.49</u>	<u>1098</u>	<u>2.71</u>	<u>1142</u>	<u>2.94</u>	<u>1186</u>	<u>3.18</u>	—	—
	4,000	<u>1058</u>	<u>2.90</u>	<u>1101</u>	<u>3.13</u>	<u>1143</u>	<u>3.36</u>	<u>1184</u>	<u>3.60</u>	—	—	—	—
	4,500	<u>1116</u>	<u>3.66</u>	<u>1157</u>	<u>3.91</u>	<u>1196</u>	<u>4.16</u>	—	—	—	—	—	—
	5,000	<u>1176</u>	<u>4.56</u>	—	—	—	—	—	—	—	—	—	—

### LEGEND

ESP — External Static Pressure

**Bold** indicates field-supplied drive or motor is required.

Plain type indicates standard motor and standard drive.

Underline indicates a different motor and drive combination other than the standard motor and standard drive combination is required. Refer to fan motor and drive tables to complete selection.

# PERFORMANCE DATA (cont.)

## DUCT SOUND POWER LEVELS (Lw)

MODEL	SIZE	CFM	dB(A)	OCTAVE BAND CENTER FREQUENCY (Hz)						
				63	125	250	500	1000	2000	4000
FHS	072	2,400	86.3	93.2	89.2	85.2	84.2	80.2	78.2	74.2
	091	3,000	88.3	95.3	91.3	87.3	86.3	82.3	80.3	76.3
	120	4,000	91.6	98.6	94.6	90.6	89.6	85.6	83.6	79.6

### LEGEND:

ASHRAE - American Society of Heating, Refrigerating and Air Conditioning, Inc.  
 HVAC - Heating, Ventilation and Air Conditioning

### NOTES:

1. The above estimated sound power levels are based upon the ASHRAE calculation approach from the ASHRAE 1987 HVAC Systems and Applications handbook, Chapter 52.
2. Since this data is calculated, these sound power levels may be different than the actual sound power levels.
3. The acoustic center of the unit is located at the geometric center of the unit.

## FACTORY-SUPPLIED FILTER PRESSURE DROP

SIZE	UNIT	AIRFLOW (Cfm)	PRESSURE DROP (in. wg)
072	FHS	1,800	0.05
		2,400	0.08
		3,000	0.11
091	FHS	2,250	0.07
		3,000	0.11
		3,750	0.15
120	FHS	3,000	0.11
		4,000	0.17
		5,000	0.23

## ACCESSORY PLENUM AIR THROW DATA (Ft)

UNIT	AIRFLOW (Cfm)	VANE DEFLECTION		
		Straight	21°	45°
FHS072	2,400	39	33	24
FHS091	3,000	45	38	28
FHS120	4,000	55	46	33

**NOTE:** Throw distances shown are for 75 fpm terminal velocity. Use the following multipliers to determine throw values for other terminal velocities.

TERMINAL VELOCITY (Fpm)	THROW FACTOR
50	X 1.50
100	X 0.75
150	X 0.50

## ACCESSORY PRESSURE DROP (in. wg)

UNIT	AIRFLOW (Cfm)	DISCHARGE PLENUM	RETURN AIR GRILLE	Hot Water	Steam	Electric	ECONOMIZER
FHS072	1,800	0.06	0.01	0.10	0.10	0.04	0.05
	2,400	0.10	0.01	0.16	0.16	0.06	0.07
	3,000	0.14	0.02	0.23	0.23	0.10	0.09
FHS091	2,250	0.09	0.01	0.15	0.15	0.06	0.06
	3,000	0.14	0.02	0.23	0.23	0.10	0.09
	3,750	0.21	0.03	0.35	0.35	0.15	0.15
FHS120	3,000	0.14	0.02	0.23	0.23	0.10	0.09
	4,000	0.22	0.04	0.37	0.37	0.17	0.17
	5,000	0.32	0.06	0.53	0.53	0.26	0.28



# ELECTRICAL DATA

## STANDARD MOTORS

UNIT	V*-PH-Hz	VOLTAGE LIMITS	FAN MOTOR		POWER SUPPLY	
			Hp (kW)	FLA	Minimum Circuit Amps	MOCP
FHS072	208/230-1-60	187-253	1.3 (0.97)	7.6	9.5	15
	208/230-3-60	187-253	2.4 (1.79)	5.8	7.5	15
	460-3-60	414-506	2.4 (1.79)	2.6	3.3	15
	575-3-60	518-632	1.0 (0.75)	1.4	1.7	15
FHS091	208/230-1-60	187-253	2.4 (1.79)	11.0	13.8	20
	208/230-3-60	187-253	2.4 (1.79)	5.8	6.5	15
	460-3-60	414-506	2.4 (1.79)	2.6	3.3	15
	575-3-60	518-632	2.0 (1.49)	2.4	3.0	15
FHS120	208/230-3-60	187-253	2.4 (1.79)	5.8	7.3	15
	460-3-60	414-506	2.4 (1.79)	2.6	3.3	15
	575-3-60	518-632	2.0 (1.49)	2.4	3.0	15

### LEGEND

**FLA** — Full Load Amps

**MOCP** — Maximum Overcurrent Protection

\* Motors are designed for satisfactory operation within 10% of nominal voltages shown. Voltages should not exceed the limits shown in the Voltage Limits column.

### NOTES:

1. Minimum circuit amps (MCA) and MOCP values are calculated in accordance with NEC (National Electrical Code) (U.S.A. standard), Article 440.
2. Motor FLA values are established in accordance with UL (Underwriters Laboratories) Standard 1995 (U.S.A. standard).
3. Indoor fan motors 5 hp and larger meet the minimum efficiency requirements as established by the Energy Policy Act of 1992 (EPACT) effective October 24, 1997.
4. Unbalanced 3-Phase Supply Voltage  
Never operate a motor where a phase imbalance in supply voltage is greater than 2%. Use the following formula to determine the percentage of voltage imbalance.

$$\% \text{ Voltage Imbalance} = 100 \times \frac{\text{max voltage deviation from average voltage}}{\text{average voltage}}$$

Example: Supply voltage is 230-3-60



AB = 224 v

BC = 231 v

AC = 226 v

$$\text{Average Voltage} = \frac{(224 + 231 + 226)}{3} = \frac{681}{3} = 227$$

Determine maximum deviation from average voltage.

(AB) 227 - 224 = 3 v

(BC) 231 - 227 = 4 v

(AC) 227 - 226 = 1 v

Maximum deviation is 4 v.

Determine percent of voltage imbalance.

$$\% \text{ Voltage Imbalance} = 100 \times \frac{4}{227} = 1.76\%$$

This amount of phase imbalance is satisfactory as it is below the maximum allowable 2%.

**IMPORTANT:** If the supply voltage phase imbalance is more than 2%, contact your local electric utility company immediately.



# ELECTRICAL DATA (cont.)

## ALTERNATE MOTORS

UNIT	V*-PH-Hz	VOLTAGE LIMITS	FAN MOTOR		POWER SUPPLY	
			Hp (kW)	FLA	Minimum Circuit Amps	MOCP
FHS072	208/230-1-60	187-253	2.4 (1.79)	11.0	13.8	20
	208/230-3-60	187-253	2.9 (2.16)	7.5	9.4	15
	460-3-60	414-506	2.9 (2.16)	3.4	4.3	15
	575-3-60	518-632	2.0 (1.49)	2.3	2.9	15
FHS091	208/230-1-60	187-253	2.4 (1.79)	11.0	13.8	15
	208/230-3-60	187-253	2.9 (2.16)	7.5	9.4	15
	460-3-60	414-506	2.9 (2.16)	3.4	4.3	15
	575-3-60	518-632	3.0 (2.24)	3.8	4.8	15
FHS120	208/230-3-60	187-253	3.7 (2.76)	10.2	12.8	20
	460-3-60	414-506	3.7 (2.76)	4.8	6.0	15
	575-3-60	518-632	3.0 (2.24)	3.8	4.8	15

### LEGEND

**FLA** — Full Load Amps

**MOCP** — Maximum Overcurrent Protection

\* Motors are designed for satisfactory operation within 10% of nominal voltages shown. Voltages should not exceed the limits shown in the Voltage Limits column.

### NOTES:

1. Minimum circuit amps (MCA) and MOCP values are calculated in accordance with NEC (National Electrical Code) (U.S.A. standard), Article 440.
2. Motor FLA values are established in accordance with UL (Underwriters' Laboratories) Standard 1995 (U.S.A. standard).
3. Indoor fan motors 5 hp and larger meet the minimum efficiency requirements as established by the Energy Policy Act of 1992 (EPACT) effective October 24, 1997.
4. Unbalanced 3-Phase Supply Voltage  
Never operate a motor where a phase imbalance in supply voltage is greater than 2%. Use the following formula to determine the percentage of voltage imbalance.

$$\% \text{ Voltage Imbalance} = 100 \times \frac{\text{max voltage deviation from average voltage}}{\text{average voltage}}$$

Example: Supply voltage is 230-3-60



AB = 224 v

BC = 231 v

AC = 226 v

$$\text{Average Voltage} = \frac{(224 + 231 + 226)}{3} = \frac{681}{3} = 227$$

Determine maximum deviation from average voltage.

(AB) 227 - 224 = 3 v

(BC) 231 - 227 = 4 v

(AC) 227 - 226 = 1 v

Maximum deviation is 4 v.

Determine percent of voltage imbalance.

$$\% \text{ Voltage Imbalance} = 100 \times \frac{4}{227} = 1.76\%$$

This amount of phase imbalance is satisfactory as it is below the maximum allowable 2%.

**IMPORTANT:** If the supply voltage phase imbalance is more than 2%, contact your local electric utility company immediately.



# ELECTRICAL DATA (cont.)

## ELECTRIC HEATER DATA

HEATER PART NO.	SIZE	V-PH-Hz	FAN MOTOR			ELECTRIC HEATER(S)							
			Hp	kW	FLA	Nominal Capacity (kW)	Actual Capacity (kW)			FLA	MCA*	MOCP*	
							Stage 1	Stage 2	Total				
AAHC05AHA	208-3-60		1.3†	0.97	7.6	5	3.8	—	3.8	10.4	22.5	25	
			2.4†	1.79	11.0	5	3.8	—	3.8	10.4	26.8	35	
			2.4	1.79	5.2	5	3.8	—	3.8	10.4	19.5	20	
			2.9	2.16	7.5	5	3.8	—	3.8	10.4	22.4	25	
			3.7	2.76	10.2	5	3.8	—	3.8	10.4	25.8	30	
	240-3-60			1.3†	0.97	7.6	5	5.0	—	5.0	12.0	24.5	25
				2.4†	1.79	11.0	5	5.0	—	5.0	12.0	28.8	35
				2.4	1.79	5.2	5	5.0	—	5.0	12.0	21.5	25
				2.9	2.16	7.5	5	5.0	—	5.0	12.0	24.4	25
				3.7	2.76	10.2	5	5.0	—	5.0	12.0	27.8	30
AAHC05ALA	480-3-60		2.4	1.79	2.6	5	5.0	—	5.0	6.00	10.8	15	
			2.9	2.16	3.4	5	5.0	—	5.0	6.00	11.8	15	
			3.7	2.76	4.8	5	5.0	—	5.0	6.00	13.5	15	
AAHC05ASA	575-3-60		1.0	0.75	1.4	5	5.0	—	5.0	5.00	8.0	15	
			2.0	1.49	2.3	5	5.0	—	5.0	5.00	9.2	15	
			3.0	2.24	3.8	5	5.0	—	5.0	5.00	11.0	15	
AAHC10AHA	208-3-60	FHS 072-120	1.3†	0.97	7.6	10	7.5	—	7.5	20.8	35.6	40	
			2.4†	1.79	11.0	10	7.5	—	7.5	20.8	39.8	40	
			2.4	1.79	5.2	10	7.5	—	7.5	20.8	32.6	35	
			2.9	2.16	7.5	10	7.5	—	7.5	20.8	35.4	40	
			3.7	2.76	10.2	10	7.5	—	7.5	20.8	38.8	40	
	240-3-60			1.3†	0.97	7.6	10	10.0	—	10.0	24.1	39.6	40
				2.4†	1.79	11.0	10	10.0	—	10.0	24.1	43.8	50
				2.4	1.79	5.2	10	10.0	—	10.0	24.1	36.6	40
				2.9	2.16	7.5	10	10.0	—	10.0	24.1	39.4	40
				3.7	2.76	10.2	10	10.0	—	10.0	24.1	42.8	50
AAHC10ALA	480-3-60		2.4	1.79	2.6	10	10.0	—	10.0	12.0	18.3	20	
			2.9	2.16	3.4	10	10.0	—	10.0	12.0	19.3	20	
			3.7	2.76	4.8	10	10.0	—	10.0	12.0	21.0	25	
AAHC10ASA	575-3-60		1.0	0.75	1.4	10	10.0	—	10.0	10.0	14.3	15	
			2.0	1.49	2.3	10	10.0	—	10.0	10.0	15.4	20	
			3.0	2.24	3.8	10	10.0	—	10.0	10.0	17.3	20	
AAHC15AHA	208-3-60		1.3†	0.97	7.6	15	11.3	—	11.3	31.3	48.6	50	
			2.4†	1.79	11.0	15	11.3	—	11.3	31.3	52.9	60	
			2.4	1.79	5.2	15	11.3	—	11.3	31.3	45.6	50	
			2.9	2.16	7.5	15	11.3	—	11.3	31.3	48.5	50	
			3.7	2.76	10.2	15	11.3	—	11.3	31.3	51.9	60	
	240-3-60			1.3†	0.97	7.6	15	15.0	—	15.0	36.1	54.6	60
				2.4†	1.79	11.0	15	15.0	—	15.0	36.1	58.9	60
				2.4	1.79	5.2	15	15.0	—	15.0	36.1	51.6	60
				2.9	2.16	7.5	15	15.0	—	15.0	36.1	54.5	60
				3.7	2.76	10.2	15	15.0	—	15.0	36.1	57.9	60

**LEGEND**

**FLA** — Full Load Amps

**Hp** — Horsepower

**MCA** — Minimum Circuit Amps

**MOCP** — Maximum Overcurrent Protection (Amps)

\* Values shown are for single-point connection of electric heat accessory and air handler.

† Single-phase motors. All other motors are 3-phase.

**NOTES:**

- Electrical resistance heaters are rated at 240 v, 480 v, or 575 v. To determine heater capacity (kW) at unit nameplate multiply the 240-v, 480-v, or 575-v capacity (kW) by the factor shown in the table below for the unit voltage.

2. The following equation converts kW of heat energy to Btuh: kW x 3,412 = Btuh.

3. Heater contactor coils are 24 v and require 8 va holding current.

4. Electric heaters are tested and ETL approved at maximum total external static pressure of 1.9 in. wg.

5. MCA and MOCP values apply to both standard and alternate factory-supplied motors.

6. Approximate shipping weight for AAHC05AHA – AAHC15AHA is 55 lb (25 kg) each.



HEATER RATING VOLTAGE	ACTUAL HEATER VOLTAGE										
	200	208	230	240	400	440	460	480	550	575	600
240	0.694	0.751	0.918	1	—	—	—	—	—	—	—
480	—	—	—	—	0.694	0.84	0.918	1	—	—	—
575	—	—	—	—	—	—	—	—	0.915	1	1.089

# ELECTRICAL DATA (cont.)

## ELECTRIC HEATER DATA (cont.)

HEATER PART NO.	SIZE	V-PH-Hz	FAN MOTOR		ELECTRIC HEATER(S)							
					Hp	kW	FLA	Nom. Capacity (kW)	Actual Capacity (kW)			FLA
			Stage 1	Stage 2					Total			
AAHC15ALA		480-3-60	2.4	1.79	2.6	15	15.0	—	15.0	18.0	25.8	30
			2.9	2.16	3.4	15	15.0	—	15.0	18.0	26.8	30
			3.7	2.76	4.8	15	15.0	—	15.0	18.0	28.6	30
AAHC15ASA		575-3-60	1.0	0.75	1.4	15	15.0	—	15.0	15.1	20.6	25
			2.0	1.49	2.3	15	15.0	—	15.0	15.1	21.7	25
			3.0	2.24	3.8	15	15.0	—	15.0	15.1	23.6	25
AAHC25AHA	FHS 072-120	208-3-60	1.3†	0.97	7.6	25	11.3	7.5	18.8	52.1	74.7	80
			2.4†	1.79	11.0	25	11.3	7.5	18.8	52.1	78.9	80
			2.4	1.79	5.2	25	11.3	7.5	18.8	52.1	71.7	80
			2.9	2.16	7.5	25	11.3	7.5	18.8	52.1	74.5	80
			3.7	2.76	10.2	25	11.3	7.5	18.8	52.1	77.9	80
			1.3†	0.97	7.6	25	15.0	10.0	25.0	60.1	84.7	90
		240-3-60	2.4†	1.79	11.0	25	15.0	10.0	25.0	60.1	88.9	90
			2.4	1.79	5.2	25	15.0	10.0	25.0	60.1	81.7	90
			2.9	2.16	7.5	25	15.0	10.0	25.0	60.1	84.6	90
			3.7	2.76	10.2	25	15.0	10.0	25.0	60.1	87.9	90
			2.4	1.79	2.6	25	15.0	10.0	25.0	30.1	40.8	50
			2.9	2.16	3.4	25	15.0	10.0	25.0	30.1	41.8	50
AAHC25ALA	480-3-60	3.7	2.76	4.8	25	15.0	10.0	25.0	30.1	43.6	50	
		1.0	0.75	1.4	25	15.0	10.0	25.0	25.1	33.1	35	
		2.0	1.49	2.3	25	15.0	10.0	25.0	25.1	34.3	35	
AAHC25ASA	575-3-60	3.0	2.24	3.8	25	15.0	10.0	25.0	25.1	36.1	40	
		2.4†	1.79	11.0	35	15.0	11.3	26.3	73.0	105.0	110	
		2.4	1.79	5.2	35	15.0	11.3	26.3	73.0	97.7	100	
AAHC35CHA	FHS 091-120	208-3-60	2.9	2.16	7.5	35	15.0	11.3	26.3	73.0	100.6	110
			3.7	2.76	10.2	35	15.0	11.3	26.3	73.0	104.0	110
			2.4†	1.79	11.0	35	20.0	15.0	35.0	84.2	119.0	125
			2.4	1.79	5.2	35	20.0	15.0	35.0	84.2	111.7	125
		240-3-60	2.9	2.16	7.5	35	20.0	15.0	35.0	84.2	114.6	125
			3.7	2.76	10.2	35	20.0	15.0	35.0	84.2	118.0	125
AAHC35CLA	480-3-60	2.4	1.79	2.6	35	20.0	15.0	35.0	42.1	55.9	60	
		2.9	2.16	3.4	35	20.0	15.0	35.0	42.1	56.9	60	
		3.7	2.76	4.8	35	20.0	15.0	35.0	42.1	58.6	60	
AAHC35CSA	575-3-60	2.0	1.49	2.3	35	20.0	15.0	35.0	35.1	46.8	50	
		3.0	2.24	3.8	35	20.0	15.0	35.0	35.1	48.7	50	

### LEGEND

**FLA** — Full Load Amps

**Hp** — Horsepower

**MCA** — Minimum Circuit Amps

**MOCP** — Maximum Overcurrent Protection (Amps)

\* Values shown are for single-point connection of electric heat accessory and air handler.

† Single-phase motors. All other motors are 3-phase.

### NOTES:

- Electrical resistance heaters are rated at 240 v, 480 v, or 575 v. To determine heater capacity (kW) at unit nameplate multiply the 240-v, 480-v, or 575-v capacity (kW) by the factor shown in the table below for the unit voltage.

2. The following equation converts kW of heat energy to Btuh: kW x 3,412 = Btuh.

3. Heater contactor coils are 24 v and require 8 va holding current.

4. Electric heaters are tested and ETL approved at maximum total external static pressure of 1.9 in. wg.

5. MCA and MOCP values apply to both standard and alternate factory-supplied motors.

6. Approximate shipping weight for AAHC05AHA - AAHC15AHA is 55 lb (25 kg) each.



HEATER RATING VOLTAGE	ACTUAL HEATER VOLTAGE										
	200	208	230	240	400	440	460	480	550	575	600
240	0.694	0.751	0.918	1	—	—	—	—	—	—	—
480	—	—	—	—	0.694	0.84	0.918	1	—	—	—
575	—	—	—	—	—	—	—	—	0.915	1	1.089

# TYPICAL PIPING AND WIRING

## HORIZONTAL INSTALLATION - FHS (Typical)

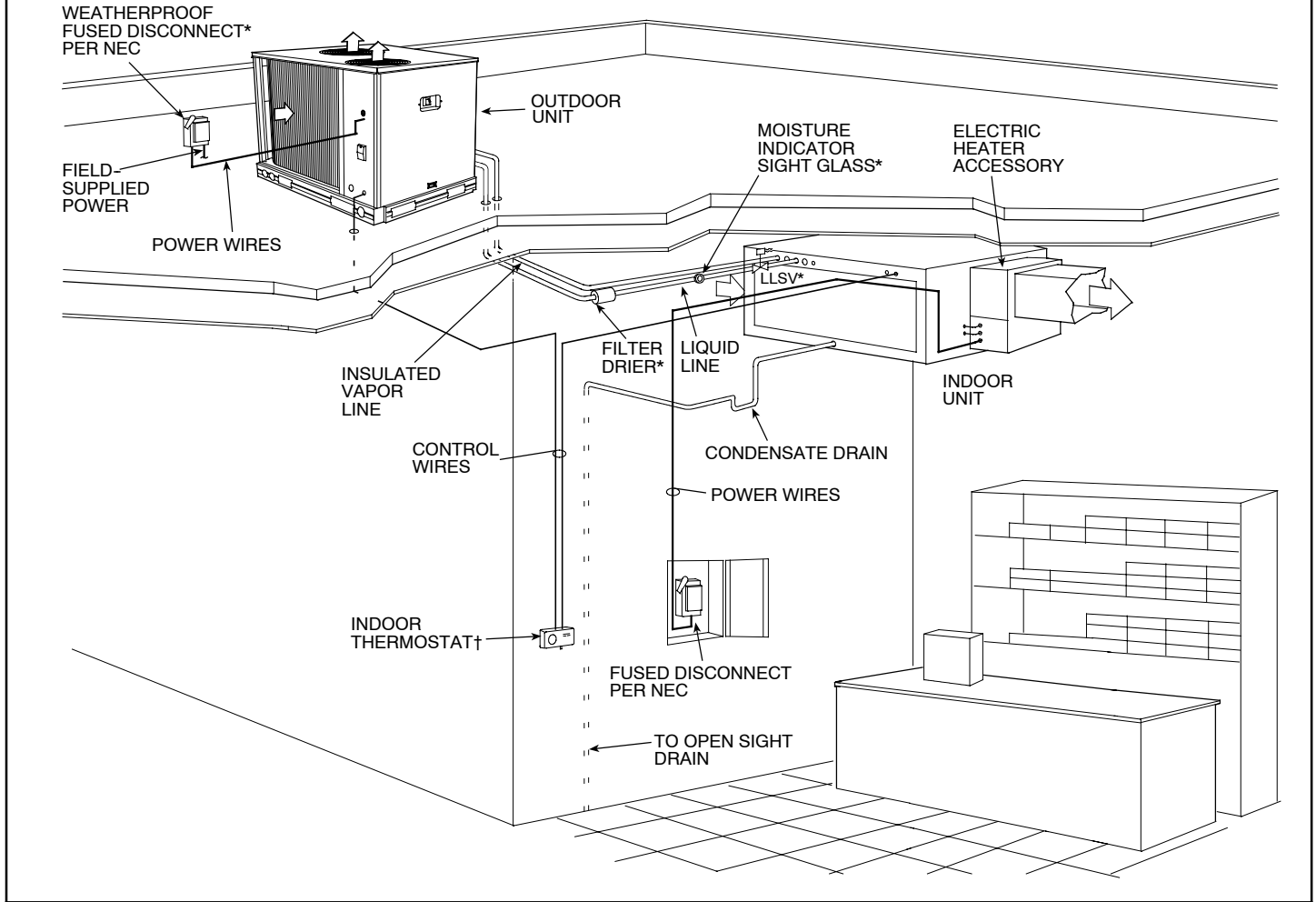

### LEGEND:

NEC - National Electrical Code

TXV - Thermostatic Expansion Valve

\* Field-supplied

† Double riser may be required. Consult condensing unit product data catalog for details.

### NOTES:

1. All piping must follow standard refrigerant piping techniques.
2. All wiring must comply with the applicable local and national codes.
3. Wiring and piping shown are general points-of-connection guides only and are not intended for, or to include all details for, a specific installation.
4. Liquid line solenoid valve (solenoid drop control) is recommended to prevent refrigerant migration to the compressor.
5. Internal factory-supplied TXVs not shown.

# TYPICAL PIPING AND WIRING (cont.)

## VERTICAL INSTALLATION - FHS (TYPICAL)

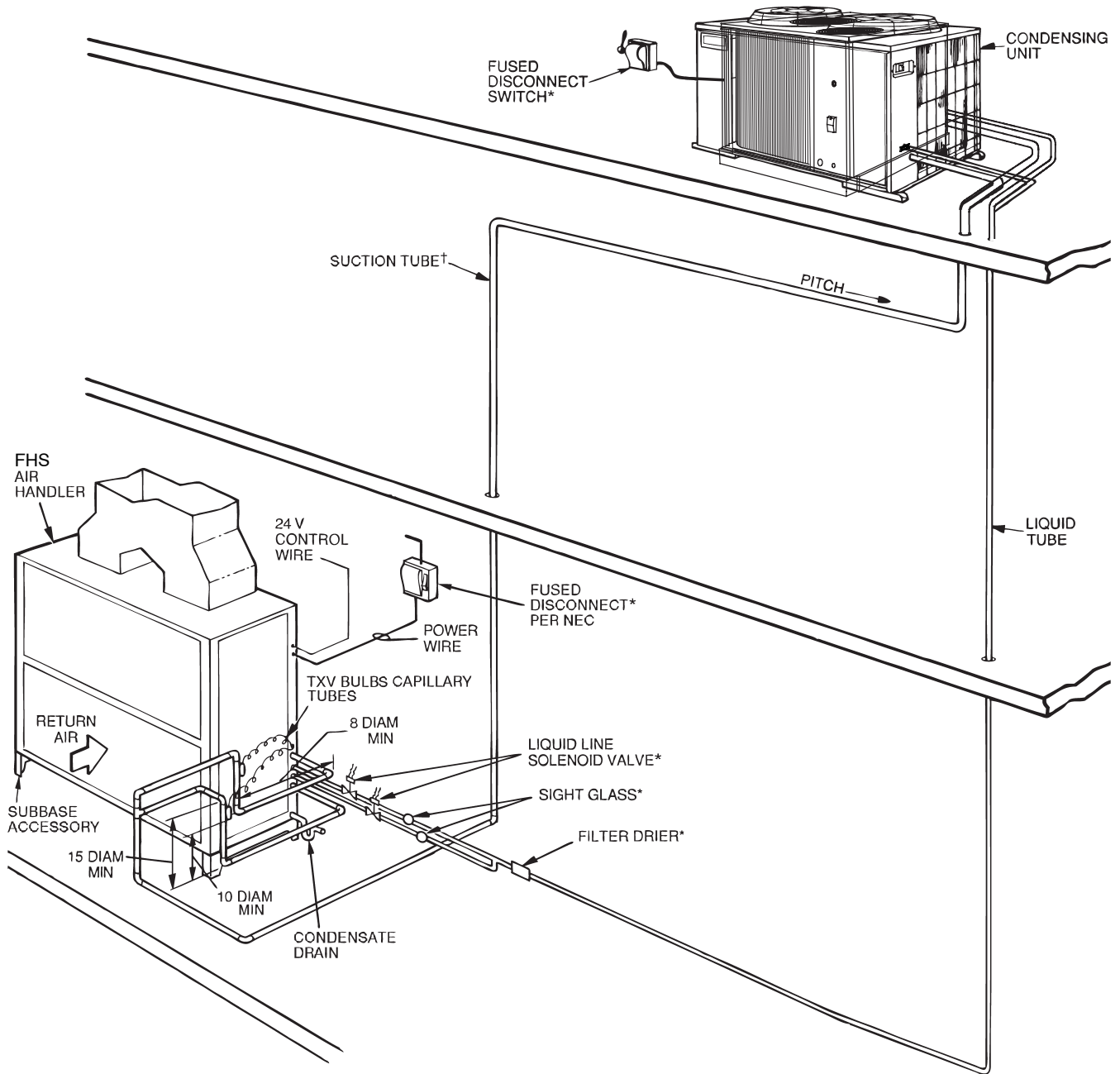

C09055

### LEGEND:

LLSV - Liquid Line Solenoid Valve  
 NEC - National Electrical Code  
 TXV - Thermostatic Expansion Valve

\* Field-supplied

† Double riser may be required Consult condensing unit product data catalog for details.

### NOTES:

1. All piping must follow standard refrigerant piping techniques.
2. All wiring must comply with the applicable local and national codes.
3. Wiring and piping shown are general points-of-connection guides only and are not intended for, or to include all details for, a specific installation.
4. Liquid line solenoid valve (solenoid drop control) is recommended to prevent refrigerant migration to the compressor.
5. Internal factory-supplied TXVs not shown.

# TYPICAL CONTROL WIRING SCHEMATIC

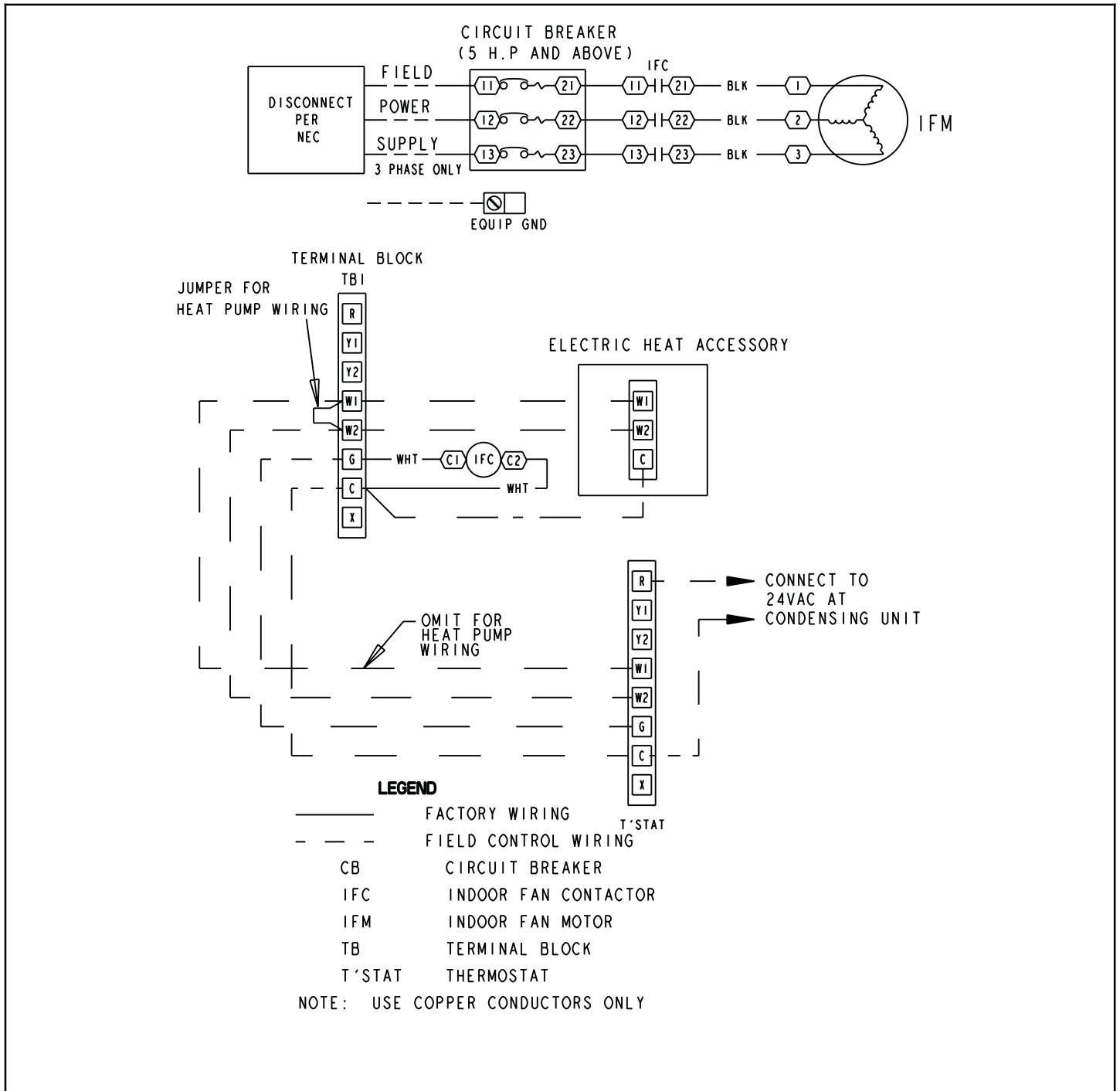

C09050

# APPLICATION DATA

## Operating limits

Maximum fan speed

FHS072-120 ..... 1200 RPM(20 R/S)

## General

**IMPORTANT:** Do not bury refrigerant piping underground.

Select equipment to match or to be slightly less than peak load. This provides better humidity control, less unit cycling, and less part-load operation. Equipment should be selected to perform at no less than 300 cfm/ton (40 L/s per kW).

The air handler fan must always be operating when the condensing unit is operating.

Ductwork should be sized according to unit size, not building load. For larger units with two fans, a split duct

transition is recommended at the fan outlets, but a plenum can be used with slight reduction in external static pressure capability.

For variable air volume (VAV) systems with supply-to-return air recycling, use the equipment room as a return air plenum.

## Hot gas bypass

Hot gas bypass may be required for low load control in certain applications. Hot gas should only be used during first stage cooling operation and should be applied to all evaporator circuits that are active at that time. To apply hot gas bypass, the FHS unit will require a field-installed auxiliary side connector(s). See the Auxiliary Side Connector Data table for part numbers.

### FACTORY-INSTALLED NOZZLE AND DISTRIBUTOR DATA

UNIT	COIL TYPE	TXV Qty...Part No.*	DISTRIBUTOR Qty...Part No.†	FEEDER TUBES PER DISTRIBUTOR Qty...Size (in.)	NOZZLE Qty...Part No.
FHS072	4 Row	1...TDEBX8	1...1116	12... <sup>1</sup> / <sub>4</sub>	1...E5
FHS091	-	1...TDEBX8	1...1657	15... <sup>1</sup> / <sub>4</sub>	1...C6
FHS120	-	2...TDEX4	2...1655	9... <sup>1</sup> / <sub>4</sub>	2...E4

#### LEGEND

TXV – Thermostatic Expansion Valve

\* Danfoss part numbers shown.

† Sporlan Valve Co. part numbers shown.

NOTE: Hot gas bypass applications require field-supplied auxiliary side connector.

### FAN MOTOR DATA STANDARD MOTOR

UNIT	FHS072	FHS091	FHS120
208/230-1-60			
Speed (rpm)	1725	1725	—
Hp	1.3	2.4	—
Frame (NEMA)	56Y	56Y	—
Shaft Dia (in.)	<sup>5</sup> / <sub>8</sub>	<sup>5</sup> / <sub>8</sub>	—
208/230-3-60 and 460-3-60			
Speed (rpm)	1725	1725	1725
Hp	2.4	2.4	2.4
Frame (NEMA)	56Y	56Y	56Y
Shaft Dia (in.)	<sup>5</sup> / <sub>8</sub>	<sup>5</sup> / <sub>8</sub>	<sup>5</sup> / <sub>8</sub>
575-3-60			
Speed (rpm)	1725	1725	1725
Hp	1.0	2.0	2.0
Frame (NEMA)	56	56HZ	56HZ
Shaft Dia (in.)	<sup>5</sup> / <sub>8</sub>	<sup>7</sup> / <sub>8</sub>	<sup>7</sup> / <sub>8</sub>

#### LEGEND:

NEMA — National Electrical Manufacturers Association (U.S.A.)

### FAN MOTOR DATA ALTERNATE MOTOR

UNIT	FHS072	FHS091	FHS120
208/230-1-60			
Speed (rpm)	1725	1725	—
Hp	2.4	2.4	—
Frame (NEMA)	56Y	56Y	—
Shaft Dia (in.)	<sup>5</sup> / <sub>8</sub>	<sup>5</sup> / <sub>8</sub>	—
230-3-60 and 460-3-60			
Speed (rpm)	1725	1725	1725
Hp	2.9	2.9	3.7
Frame (NEMA)	56Y	56Y	Y56Y
Shaft Dia (in.)	<sup>7</sup> / <sub>8</sub>	<sup>7</sup> / <sub>8</sub>	<sup>7</sup> / <sub>8</sub>
575-3-60			
Speed (rpm)	1725	1725	1725
Hp	2.0	3.0	3.0
Frame (NEMA)	56HZ	56HZ	56HZ
Shaft Dia (in.)	<sup>7</sup> / <sub>8</sub>	<sup>7</sup> / <sub>8</sub>	<sup>7</sup> / <sub>8</sub>

#### LEGEND:

NEMA — National Electrical Manufacturers Association (U.S.A.)

### MOTOR EFFICIENCY FHS

MOTOR HP	EPACT MINIMUM	MOTOR EFFICIENCY
2.0	—	82%
2.4	—	82%

#### LEGEND:

EPACT – Energy Policy and Conservation Act of 1992



# APPLICATION DATA (cont.)

## FAN MOTOR DATA STANDARD MOTOR — U.S.

UNIT	FHS072	FHS091	FHS120
<b>MOTOR DRIVE</b>			
Motor Pulley Pitch Dia (in.)	2.4-3.4	2.8-3.8	3.4-4.4
Pulley Factory Setting Full Turns Open	2.5	2.5	2.5
<b>FAN DRIVE</b>			
Pulley Pitch Dia (in.)	8.8	8.8	8.8
Pulley Bore (in.)	1	1	1
Belt No. — Section	1—A	1—A	1—A
Belt Pitch (in.)	40.3	41.3	42.3
<b>FAN SPEEDS (rpm)</b>			
Factory Settings	568	647	764
Range	470-666	549-745	666-863
Max Allowable Speed (rpm)	1200	1200	1200
Change per 1/2 turn of Moveable Motor Pulley Flange	19.6	19.6	19.7
<b>MAX FULL TURNS FROM CLOSED POSITION</b>			
	5	5	5
<b>SHAFTS CENTER DISTANCE (in.)</b>			
	10.44 - 12.32	10.44 - 12.32	10.44 - 12.32

## HIGH-STATIC DRIVE DATA

UNIT	FHS072	FHS091	FHS120
<b>MOTOR DRIVE</b>			
Motor Pulley Pitch Dia (in.)	3.4-4.4	3.4-4.4	3.4-4.4
Pulley Factory Setting Full Turns Open	2.5	2.5	2.5
<b>FAN DRIVE</b>			
Pulley Pitch Dia (in.)	7.0	6.0*	6.0
Pulley Bore (in.)	1	1	1
Belt No. — Section	1—A	1—A	1—A
Belt Pitch (in.)	41.3	37.3	37.3
<b>FAN SPEEDS (rpm)</b>			
Factory Setting	961	1121	1121
Range	838 - 1084	978 - 1200*†	978 - 1200†
Max Allowable Speed (rpm)	1200	1200	1200
Change per 1/2 Turn of Moveable Motor Pulley Flange	24.6	28.7	28.7
<b>MAX FULL TURNS FROM CLOSED POSITION</b>			
	5	5	5
<b>SHAFTS CENTER DISTANCE (in.)</b>			
	10.44 - 12.32	10.44 - 12.32	10.44 - 12.32

# GUIDE SPECIFICATIONS, FHS072-120

## Split System Heat Pump Indoor Unit (Air-Handling Unit) with R-410A Refrigerant

### HVAC Guide Specifications — Section 15859

Size Range: 1,800 to 5,000 Cfm, Nominal Airflow  
6 to 10 Tons, Nominal Cooling

#### Part 1 — General

##### 1.01 SYSTEM DESCRIPTION

- A. Indoor, packaged air-handling unit for use in commercial heat pump split systems. Unit shall have a multi-position design and shall be capable of horizontal or vertical installation on a floor or in a ceiling, with or without ductwork. (Only vertical units are to be applied without ductwork.) Unit shall function as the indoor component of an air-to-air electric heat pump system.
- B. Unit must be designed with a R-410A refrigerant circuit with a matching air-cooled condensing unit CHS, for matched systems approved by the manufacturer.

##### 1.02 QUALITY ASSURANCE

- A. All coils shall be designed and tested in accordance with ASHRAE 15 Safety Code for Mechanical Refrigeration, latest edition.
- B. Unit shall be constructed in accordance with ETL and ETL, Canada, standards and shall carry the ETL and ETL, Canada, labels.
- C. Unit insulation and adhesive shall comply with NFPA-90A requirements for flame spread and smoke generation. Insulation shall contain an EPA-registered immobilized antimicrobial agent to effectively resist the growth of bacteria and fungi as proven by tests in accordance with ASTM standards G21 and 22.
- D. Unit shall be manufactured in a facility registered to the ISO 9001:2000 manufacturing quality standard.
- E. Direct-expansion coils shall be leak tested at 150 psig and pressure tested at 650 psig and qualified to UL burst test at 1980 psig.

##### 1.03 DELIVERY AND STORAGE

Units shall be stored and handled per manufacturer's recommendations.

#### Part 2 — Products

##### 2.01 EQUIPMENT

Indoor mounted, draw-thru, packaged air-handling unit that can be used with or without ductwork in a suspended horizontal configuration or free-standing vertical configuration. Unit shall be indoor component of a heat pump system. Unit shall consist of forward-curved belt-driven centrifugal fan(s), motor and drive assembly, prewired fan motor contactor, factory-installed refrigerant metering devices, bypass check valves, cooling coil, 2-in. disposable air filters, and condensate drain pans for vertical or horizontal configurations.

- A. Base Unit:
  1. Cabinet shall be constructed of mill-galvanized steel.
  2. Cabinet panels shall be fully insulated with 1/2-in. fire-retardant material. Insulation shall contain an EPA-registered immobilized antimicrobial agent to effectively resist the growth of bacteria and fungi as proven by tests in accordance with ASTM standards G21 and 22.
  3. Unit shall contain corrosion-free condensate drain pans for both vertical and horizontal applications. Drain pans shall have connections on right and left sides of unit to facilitate field connection. Drain pans shall have the ability to be sloped toward the right or left side of the unit to prevent standing water from accumulating in pans.
  4. Unit shall have factory-supplied 2-in. throwaway-type filters installed upstream from the cooling coil. Filter access shall be from either the right or left side of the unit.
- B. Coils:
  1. Coils shall consist of 3 rows (FHS072) or 4 rows (FHS091, 120) of copper tubes with sine-wave aluminum fins bonded to the tubes by mechanical expansion. Coil tubing shall be internally rifled to maximize heat transfer. Refrigerant line connections shall be made on the same side of the coil.
  2. Coils shall feature factory-installed thermostatic expansion valves (TXVs) for refrigerant control. The TXVs shall be capable of external adjustment.
  3. Coils shall have a factory-installed bypass line and check valve assembly around the TXVs to allow liquid flow from the coil to the outdoor unit during Heating mode.
- C. Operating Characteristics:

1. When combined with the matching CHS condensing unit the system shall be capable of starting and running up to 125 F (52 C) and down to 35 F (2 C) ambient outdoor temperature.
  2. Unit shall operate at +/- 10% from rated voltage
- D. Motor:
1. Fan motor of the size and electrical characteristics specified on the equipment schedule shall be factory-supplied and factory-installed.
  2. Indoor-fan motor shall have permanently lubricated, sealed bearings and inherent automatic-reset thermal overload protection (motors smaller than 5 hp) or manual reset calibrated circuit breakers (motors equal or larger than 5 hp). Indoor motors are designed specifically and do not have conventional horsepower (hp) ratings listed on the motor nameplate. Motors are designed and qualified in the "air-over" location downstream of the cooling coil and carry a maximum continuous bhp rating that is the maximum application bhp rating for the motors; no "safety factors" above that rating may be applied.
  3. All indoor fan motors 5 hp and larger shall meet the minimum efficiency requirements as established by the Energy Policy Act of 1992 (EPACT), effective October 24, 1997.
- E. Special Features:
1. Alternate Motor and Drive:  
An alternate motor and medium or high-static drive shall be available to meet the airflow and external static pressure requirements specified on the equipment schedule.
  2. External Paint Cabinet:  
Where conditions require, units shall be painted with an American Sterling Gray finish.
  3. Hot Water Coil:  
Coil shall be 2-row, U-bend coil with copper tubes and aluminum plate fins bonded to the tubes by mechanical expansion. Coil shall be mounted in a galvanized steel housing that shall be fastened to the unit's fan deck for blow-thru heating operation. Coil shall have maximum working pressure of 150 psig.
  4. Steam Distributing Coil:  
Coil shall consist of one row of copper tubes with aluminum plate fins, and shall have inner steam distributing tubes. Coil shall be mounted in a galvanized steel housing and shall be fastened to the unit's fan deck for blow-thru heating operation. Coil shall have maximum working pressure of 20 psig at 260 F.
  5. Electric Heaters:  
Heaters for nominal 240, 480, or 575-volt, 3-phase, 60 Hz power supply shall be factory-supplied for field installation as shown on the equipment drawings. Electric heat assembly shall be ETL and ETL, Canada; agency approved, and shall have single-point power wiring. Heater assembly shall include contactors with 24-v coils, power wiring, 24-v control wiring terminal blocks, and a hinged access panel.
  6. Air Discharge Plenum:  
Plenum shall be factory-supplied to provide free-blow air distribution for vertical floor-mounted units. A grille with moveable vanes for horizontal or vertical airflow adjustment shall be included. Plenum housing shall be field-installed on the unit's fan deck for blow-thru air distribution.
  7. Return Air Grille:  
Grille shall be factory-supplied for field installation on the unit's return air opening.
  8. Unit Subbase:  
Subbase assembly shall be factory-supplied for field installation. Subbase shall elevate floor-mounted vertical units to provide access for correct condensate drain connection.
  9. Economizer:  
Economizer for ventilation or "free" cooling shall be factory-provided for field installation. For free cooling applications, economizer shall be compatible with factory-supplied thermostat; economizer dampers shall open when outdoor air enthalpy is suitable for free cooling. Economizer shall be compatible with factory-supplied CO2 sensor; economizer dampers shall open when indoor CO2 level rises above predetermined set point. Economizer shall include enthalpy control and damper actuator.
  10. Overhead Suspension Package:  
Package shall include necessary brackets to support units in a horizontal ceiling installation.
  11. CO2 Sensor:  
Sensor shall provide the ability to signal the economizer to open when the space CO2 level exceeds the predetermined set point. Sensor shall have the capability of being connected to Comfort System relay pack or to economizer using field-supplied and field-installed Honeywell dc adapter no. Q769C1004.
  12. Condensate Drain Trap:  
Trap shall have transparent, serviceable design for easy cleaning. Kit shall also include overflow shutoff switch and wiring harness for connection to alarm if desired.