



PGMF Series SPECIFICATIONS

10 SEER
PACKAGE GAS ELECTRIC UNITS
3 PHASE, 3 THRU 5 TONS

SINGLE PACKAGE

- Combination gas heating and electric cooling, self contained for year-round comfort. Systems can be installed on rooftop or ground level with the new convertible design.

CABINET

- 20 gauge hot dipped galvanized steel, phosphate-coated with a tough acrylic finish. One piece weather resistant top. Access panels for easy service. Side by side supply and return. Heavy gauge base with rails.

INTEGRAL BASE RAILS

- Fork-lift access on three sides. Holes provided for lifting lugs makes rooftop installation easier.

IMPROVED INSULATION

- Dual density insulation improves temperature separation.

INDOOR BLOWER

- Adjustable Electronic Fan Control with optional low speed, continuous fan feature responds quickly to circulate heated air and provide maximum comfort.
- Standard direct drive blower on all models.
- "No Difference" Design - Unit will operate at the same rated External Static Pressure in the down shot or horizontal duct position.

INTERNAL AIR FILTERS

- Easy access air filters to maintain a clean evaporator coil.

COPPER TUBE/ALUMINUM FIN COILS

- Enhanced aluminum fins mechanically bonded to 3/8" copper tubes for improved heat transfer.

FILTER DRIERS

- To insure refrigerant cleanliness.

HIGH & LOW PRESSURE SWITCHES

- To provide excellent compressor protection.

FREEZE THERMOSTAT

- Mounted to evaporator, prevents coil freeze up.

EXTERNALLY-MOUNTED GAUGE PORTS

- Allows for more accurate reading of operating conditions while servicing.

INDUCED DRAFT COMBUSTION SYSTEM

- For smoother combustion and optimal efficiency.

ALUMINIZED TUBULAR HEAT EXCHANGER

- Tubular design delivers efficient heat transfer and air flow: aluminized coating protects against corrosion.

IGNITION SYSTEM

- Honeywell Electronic Hot Surface/Pilot (HSP) Ignition system.

COMPRESSORS

- Scroll compressors on 4 and 5 ton models, Recip compressor on 3 ton model.

IN-SHOT BURNERS

- New design delivers more complete, efficient combustion.



PRE-WIRED FOR ECONOMIZER

- Designed for slide in, plug in economizer installation.

65VA TRANSFORMER

- Standard 65 VA transformer has built-in secondary circuit breaker and is standard on all models.

WARRANTY

- One (1) year limited warranty on parts.
- Five (5) year limited warranty on the compressor.
- Ten (10) year limited warranty on the gas fired heat exchanger.

UNIT SPECIFICATIONS

MODEL NUMBER	Electrical Data				Condenser Data								
	Voltage Phase - Hz	Max. Fuse	Ampacity	Total Unit Amps	Coil			Fan Motor			Fan		
					Total Face Area Sq. Feet (Sq. Meters)	Fins Per In. / Rows	Tube Diameter In.(mm.)	Horsepower	Full Load Amps	Locked Rotor Amps	Size Diameter In.(mm)	RPM (Max.)	CFM (Max.)
PGMF36H090A	208/230-3-60	25	17.8	15.6	12.5 (1.16)	20 / 1	3/8 (9.52)	.75	2.6	9.52	22(558.8)	1165	3500
PGMF36F090A	460-3-60	15	9.1	8.0				.75	1.4	4.8			
PGMF36H135A	208/230-3-60	25	18.8	16.6				.75	2.6	9.5			
PGMF48H090A	208/230-3-60	35	23.4	20.1	17.2 (1.6)	20 / 1	3/8 (9.52)	.75	2.6	9.52	22(558.8)	1155	4500
PGMF48F090A	460-3-60	15	11.8	10.2				.75	1.4	5.04			
PGMF48H135A	208/230-3-60	35	23.6	20.3				.75	2.6	9.52			
PGMF48F135A	460-3-60	15	11.9	10.3	17.2	20 / 1	3/8	.75	1.4	5.04	22	1155	4500
PGMF60H090A	208/230-3-60	50	34.2	28.9				.75	2.6	9.52			
PGMF60F090A	460-3-60	20	15.3	13.0				.75	1.4	5.4			
PGMF60H115A	208/230-3-60	50	34.2	28.9	17.2	20 / 1	3/8	.75	2.6	9.52	22	1155	4500
PGMF60F115A	460-3-60	20	15.3	13.0				.75	1.4	5.4			
PGMF60H150A	208/230-3-60	50	35.2	29.9				.75	2.6	9.52			
PGMF60F150A	460-3-60	20	15.8	13.5	17.2	20 / 1	3/8	.75	1.4	5.4	22	1155	4500
PGMF60H090A	208/230-3-60	50	34.2	28.9				.75	2.6	9.52			
PGMF60F090A	460-3-60	20	15.3	13.0				.75	1.4	5.4			

MODEL NUMBER	Evaporator Coil											Factory Refrigerant Charge R-22 Oz.	Sound Rating (Bels)	Ship. Weight Lbs.(Kg)
	Coil			Blower		Motor		Blower		Compressor				
	Total Face Area Sq. Feet (Sq. Meters)	Fins Per In. / Rows	Tube Diameter In.(mm)	Blower H.P. / Type / Speeds	Full Load Amps	Locked Rotor Amps	Type & Size	RPM (Maximum)	CFM Rated	Full Load Amps	Locked Rotor Amps			
PGMF36H090A	8.2 (.76)	15 / 2	3/8 (9.52)	.5 / PSC / 4	4.0	7.1	DD10-8	1090	1200	9.0	70	104	8.0	590(267.6)
PGMF36F090A				4.0	7.1	4.6				33				
PGMF36H135A				1 / PSC / 4	5.0	11.1				9.0	70			
PGMF48H090A	8.2	15 / 2	3/8 (9.52)	.5 / PSC / 4	4.4	8.6	DD10-9	1110	1600	13.1	91	113	7.8	610(276.7)
PGMF48F090A				.5 / PSC / 4	4.4	8.6				6.6	46			
PGMF48H135A				1 / PSC / 3	4.6	7.9				13.1	91			
PGMF48F135A				1 / PSC / 3	4.6	7.9				6.6	46			
PGMF60H090A	8.2 (.76)	14 / 3	3/8 (9.52)	1 / PSC / 4	5.0	8.7	DD11-11	1050	2000	21.3	128	99	8.0	635(288.0)
PGMF60F090A					5.0	8.7		7.9		63	635(288.0)			
PGMF60H115A					5.0	8.7		21.3		128	630(285.0)			
PGMF60F115A					5.0	8.7		9.1		63	635(288.0)			
PGMF60H150A					6.0	15.1		21.3		128	640(290.3)			
PGMF60F150A					6.0	15.1		9.1		63	640(290.3)			

MODEL NUMBER IDENTIFICATION GUIDE

MODEL NUMBER	P	G	M	F	36	H	090
Package							
Gas / Electric Unit							
Multi-Position							
DesignSeries							
F = 3 Phase, Direct Drive Blower							
							Gas Heat Input 90= 90,000 135=135,000 115=115,000 150=150,000
							Electrical Characteristics H = 208 / 230-3-60 F = 460-3-60
							Capacity (Nominal BTU) 036 = 3 Ton 048 = 4 Ton 060 = 5 Ton

PERFORMANCE DATA: HEATING

MODEL NUMBER	Input (MBTUH)		Output (MBTUH)		Efficiency *				Temperature Rise ° F (° C)	Gas Piping Size Inches(mm)	Transformer Size VA.
	Standard	Low Fire Kit ¹	Standard	Low Fire Kit ¹	DOE (AFUE)		Calif. (CSE)				
					Std.	L.F.K. ²	Std.	L.F.K. ²			
PGMF36H090A	90	75	71	60	80.7	81.4	76.3	76.9	35 - 65(17.4 - 34.1)	1/2(12.7)	65 VA
PGMF36F090A	90	75	71	60							
PGMF36H135A	135	110	106	86	80.3	80.7	76.0	75.7			
PGMF48H090A	90	75	71	60	80.8	81.5	75.7	76.2	30 - 60(14.6 - 31.3)	1/2(12.7)	65 VA
PGMF48F090A	90	75	71	60	80.8	81.5	75.7	76.2			
PGMF48H135A	135	110	106	87	80.4	80.7	76.1	76.4			
PGMF48F135A	135	110	106	87	80.4	80.7	76.1	76.4	35 - 65(17.4 - 34.1)		
PGMF60H090A	90	75	71	59	80.7	81.3	75.5	75.9	30 - 60(14.6 - 31.3)	1/2(12.7)	65 VA
PPGMF60F090A	90	75	71	60	80.8	80.1	76.0	75.7			
PGMF60H115A	115	95	91	75	80.8	80.9	76.0	75.8			
PGMF60F115A	150	130	119	102	80.8	80.1	76.0	75.7	35 - 65(17.4 - 34.1)		
PGMF60H150A	115	95	91	75	80.8	80.9	76.0	75.8	30 - 60(14.6 - 31.3)		
PGMF60F150A	150	130	119	102	80.8	80.1	76.0	75.7	35 - 65(17.4 - 34.1)		

¹ Field conversion kit available for lower fire rate. ² Low Fire Conversion Kit. * As determined by D.O.E. Steady State Efficiency Rating Test. Heating capacity valid for elevations up to 2,000 feet (609.6 meters) above sea level. For elevations above 2,000 feet (609.6 meters), rated capacity should be reduced by 4% for each 1,000 feet (304.5 meters) above sea level.

PERFORMANCE DATA: COOLING

MODEL NUMBER	Rated Capacity BTUH	S / T Ratio	S.E.E.R.	E.E.R.	Power Input Watts	Evaporator Rated Airflow (SCFM)
PGMF36	34,500	.77	10.2	9.05	3812	1200
PGMF48	45,000	.78	10	8.75	5085	1600
PGMF60	58,500	.76	10	8.55	7090	2000

* Rated Capacity @ 230 Volts. For applications at 208 volts deduct 1000 BTU.

EXPANDED PERFORMANCE DATA (COOLING) - 3 Ton

Airflow IDB* CFM			Outdoor Ambient Temperature - Degrees F. Dry Bulb																							
			65				75				85				95				105				115			
			Entering Indoor Temperature - Degrees F. Wet Bulb																							
			59	63	67	71	59	63	67	71	59	63	67	71	59	63	67	71	59	63	67	71	59	63	67	71
70	1344	MBh	33.8	35.0	38.4	-	33.0	34.2	37.5	-	32.2	33.4	36.6	-	31.4	32.6	35.7	-	29.9	31.0	33.9	-	27.7	28.7	31.4	-
		S/T	0.77	0.65	0.45	-	0.80	0.67	0.46	-	0.82	0.69	0.48	-	0.85	0.71	0.49	-	0.88	0.74	0.51	-	0.89	0.74	0.51	-
		KW	3.04	3.10	3.19	-	3.25	3.31	3.41	-	3.44	3.50	3.61	-	3.60	3.67	3.78	-	3.74	3.81	3.93	-	3.86	3.94	4.06	-
	1200	MBh	32.8	34.0	37.3	-	32.1	33.2	36.4	-	31.3	32.4	35.5	-	30.5	31.6	34.7	-	29.0	30.1	32.9	-	26.9	27.8	30.5	-
		S/T	0.74	0.62	0.43	-	0.76	0.64	0.44	-	0.78	0.65	0.45	-	0.81	0.68	0.47	-	0.84	0.70	0.49	-	0.85	0.71	0.49	-
		KW	3.02	3.08	3.16	-	3.23	3.29	3.39	-	3.41	3.48	3.58	-	3.57	3.64	3.75	-	3.71	3.79	3.90	-	3.83	3.91	4.03	-
1056	MBh	31.2	32.3	35.4	-	30.5	31.6	34.6	-	29.7	30.8	33.8	-	29.0	30.1	32.9	-	27.6	28.6	31.3	-	25.5	26.5	29.0	-	
	S/T	0.71	0.59	0.41	-	0.73	0.61	0.42	-	0.75	0.63	0.43	-	0.78	0.65	0.45	-	0.80	0.67	0.47	-	0.81	0.68	0.47	-	
	KW	2.98	3.03	3.12	-	3.18	3.24	3.34	-	3.36	3.43	3.53	-	3.52	3.59	3.70	-	3.65	3.73	3.84	-	3.77	3.85	3.96	-	
75	1344	MBh	34.4	35.4	38.3	41.1	33.6	34.6	37.4	40.2	32.8	33.8	36.5	39.2	32.0	32.9	35.6	38.3	30.4	31.3	33.9	36.3	28.1	29.0	31.4	33.7
		S/T	0.88	0.79	0.60	0.38	0.91	0.81	0.62	0.40	0.93	0.84	0.63	0.41	0.96	0.86	0.65	0.42	1.00	0.90	0.68	0.44	1.00	0.90	0.68	0.44
		KW	3.06	3.12	3.21	3.30	3.28	3.34	3.44	3.54	3.46	3.53	3.64	3.75	3.63	3.70	3.81	3.93	3.77	3.84	3.96	4.08	3.89	3.97	4.09	4.22
	1200	MBh	33.4	34.4	37.2	39.9	32.6	33.6	36.3	39.0	31.8	32.8	35.5	38.1	31.1	32.0	34.6	37.1	29.5	30.4	32.9	35.3	27.3	28.1	30.5	32.7
		S/T	0.84	0.75	0.57	0.37	0.87	0.78	0.59	0.38	0.89	0.80	0.60	0.39	0.92	0.82	0.62	0.40	0.95	0.85	0.65	0.42	0.96	0.86	0.65	0.42
		KW	3.04	3.10	3.19	3.28	3.25	3.31	3.41	3.51	3.44	3.50	3.61	3.72	3.60	3.67	3.78	3.90	3.74	3.81	3.93	4.05	3.86	3.94	4.06	4.19
1056	MBh	31.7	32.6	35.3	37.9	31.0	31.9	34.5	37.0	30.2	31.1	33.7	36.2	29.5	30.4	32.9	35.3	28.0	28.9	31.2	33.5	26.0	26.7	28.9	31.0	
	S/T	0.80	0.72	0.54	0.35	0.83	0.74	0.56	0.36	0.85	0.76	0.58	0.37	0.88	0.79	0.60	0.38	0.91	0.82	0.62	0.40	0.92	0.82	0.62	0.40	
	KW	3.00	3.06	3.14	3.23	3.20	3.27	3.36	3.46	3.39	3.45	3.55	3.66	3.55	3.62	3.72	3.84	3.68	3.76	3.87	3.99	3.80	3.88	3.99	4.12	
80	1344	MBh	35.0	35.8	38.2	40.8	34.2	34.9	37.3	39.9	33.4	34.1	36.4	38.9	32.6	33.3	35.5	38.0	30.9	31.6	33.8	36.1	28.6	29.3	31.3	33.4
		S/T	0.96	0.90	0.74	0.55	1.00	0.94	0.76	0.57	1.00	0.96	0.78	0.58	1.00	1.00	0.81	0.60	1.00	1.00	0.84	0.63	1.00	1.00	0.84	0.63
		KW	3.09	3.14	3.23	3.33	3.30	3.36	3.46	3.57	3.49	3.56	3.66	3.77	3.65	3.73	3.84	3.96	3.80	3.87	3.99	4.12	3.92	4.00	4.12	4.25
	1200	MBh	34.0	34.7	37.1	39.6	33.2	33.9	36.2	38.7	32.4	33.1	35.4	37.8	31.6	32.3	34.5	36.9	30.0	30.7	32.8	35.0	27.8	28.4	30.4	32.5
		S/T	0.92	0.86	0.70	0.52	0.95	0.89	0.73	0.54	0.98	0.92	0.75	0.56	1.00	0.95	0.77	0.58	1.00	0.98	0.80	0.60	1.00	0.99	0.81	0.60
		KW	3.06	3.12	3.21	3.30	3.28	3.34	3.44	3.54	3.46	3.53	3.64	3.75	3.63	3.70	3.81	3.93	3.77	3.84	3.96	4.08	3.89	3.97	4.09	4.22
1056	MBh	32.3	33.0	35.2	37.7	31.5	32.2	34.4	36.8	30.8	31.4	33.6	35.9	30.0	30.7	32.8	35.0	28.5	29.1	31.1	33.3	26.4	27.0	28.8	30.8	
	S/T	0.88	0.83	0.67	0.50	0.91	0.86	0.70	0.52	0.94	0.88	0.71	0.53	0.97	0.91	0.74	0.55	1.00	0.94	0.77	0.57	1.01	0.95	0.77	0.58	
	KW	3.02	3.08	3.16	3.26	3.23	3.29	3.39	3.49	3.41	3.48	3.58	3.69	3.57	3.64	3.75	3.87	3.71	3.79	3.90	4.02	3.83	3.91	4.03	4.15	
85	1344	MBh	35.6	36.3	38.0	40.6	34.8	35.4	37.1	39.6	33.9	34.6	36.2	38.7	33.1	33.8	35.4	37.7	31.5	32.1	33.6	35.8	29.1	29.7	31.1	33.2
		S/T	1.00	0.98	0.88	0.71	1.00	1.00	0.91	0.74	1.00	1.00	0.94	0.76	1.00	1.00	0.97	0.78	1.00	1.00	1.00	0.81	1.00	1.00	1.00	0.82
		KW	3.11	3.17	3.26	3.35	3.32	3.39	3.49	3.59	3.51	3.58	3.69	3.80	3.68	3.76	3.87	3.99	3.83	3.90	4.02	4.15	3.95	4.03	4.16	4.29
	1200	MBh	34.6	35.2	36.9	39.4	33.8	34.4	36.0	38.5	33.0	33.6	35.2	37.5	32.2	32.8	34.3	36.6	30.5	31.1	32.6	34.8	28.3	28.8	30.2	32.2
		S/T	0.96	0.93	0.84	0.68	1.00	0.96	0.87	0.71	1.00	0.99	0.89	0.72	1.00	1.00	0.92	0.75	1.00	1.00	0.96	0.78	1.00	1.00	0.96	0.78
		KW	3.09	3.14	3.23	3.33	3.30	3.36	3.46	3.57	3.49	3.56	3.66	3.77	3.65	3.73	3.84	3.96	3.80	3.87	3.99	4.12	3.92	4.00	4.12	4.25
1056	MBh	32.8	33.5	35.1	37.4	32.1	32.7	34.2	36.5	31.3	31.9	33.4	35.7	30.5	31.1	32.6	34.8	29.0	29.6	31.0	33.1	26.9	27.4	28.7	30.6	
	S/T	0.92	0.89	0.80	0.65	0.96	0.92	0.83	0.68	0.98	0.95	0.85	0.69	1.00	0.98	0.88	0.72	1.00	1.00	0.92	0.74	1.00	1.00	0.92	0.75	
	KW	3.04	3.10	3.19	3.28	3.25	3.31	3.41	3.51	3.44	3.50	3.61	3.72	3.60	3.67	3.78	3.90	3.74	3.81	3.93	4.05	3.86	3.94	4.06	4.18	

* Entering Indoor Temperature - Degrees F. Dry Bulb

□ Standard Rating

EXPANDED PERFORMANCE DATA (COOLING) - 4 Ton

Airflow IDB* CFM			Outdoor Ambient Temperature - Degrees F. Dry Bulb																							
			65				75				85				95				105				115			
			Entering Indoor Temperature - Degrees F. Wet Bulb																							
			59	63	67	71	59	63	67	71	59	63	67	71	59	63	67	71	59	63	67	71	59	63	67	71
			70	1792	MBh	44.1	45.7	50.1	-	43.1	44.6	48.9	-	42.0	43.6	47.7	-	41.0	42.5	46.6	-	39.0	40.4	44.3	-	36.1
S/T	0.78	0.65			0.45	-	0.81	0.68	0.47	-	0.83	0.70	0.48	-	0.86	0.72	0.50	-	0.89	0.74	0.52	-	0.90	0.75	0.52	-
KW	4.03	4.11			4.23	-	4.32	4.40	4.54	-	4.57	4.66	4.81	-	4.79	4.89	5.04	-	4.98	5.09	5.25	-	5.15	5.26	5.42	-
1600	MBh	42.8		44.4	48.6	-	41.8	43.3	47.5	-	40.8	42.3	46.4	-	39.8	41.3	45.2	-	37.8	39.2	43.0	-	35.0	36.3	39.8	-
	S/T	0.75		0.62	0.43	-	0.77	0.65	0.45	-	0.79	0.66	0.46	-	0.82	0.68	0.47	-	0.85	0.71	0.49	-	0.86	0.72	0.50	-
	KW	4.00		4.08	4.20	-	4.29	4.37	4.50	-	4.54	4.63	4.77	-	4.76	4.86	5.00	-	4.95	5.05	5.21	-	5.11	5.21	5.38	-
1408	MBh	40.7	42.2	46.2	-	39.7	41.2	45.1	-	38.8	40.2	44.0	-	37.8	39.2	43.0	-	35.9	37.3	40.8	-	33.3	34.5	37.8	-	
	S/T	0.72	0.60	0.41	-	0.74	0.62	0.43	-	0.76	0.64	0.44	-	0.79	0.66	0.45	-	0.81	0.68	0.47	-	0.82	0.69	0.48	-	
	KW	3.94	4.02	4.14	-	4.22	4.31	4.43	-	4.47	4.56	4.70	-	4.68	4.78	4.93	-	4.87	4.97	5.12	-	5.03	5.13	5.29	-	
75	1792	MBh	44.8	46.2	50.0	53.6	43.8	45.1	48.8	52.4	42.8	44.0	47.7	51.1	41.7	42.9	46.5	49.9	39.6	40.8	44.2	47.4	36.7	37.8	40.9	43.9
		S/T	0.89	0.80	0.60	0.39	0.92	0.83	0.62	0.40	0.95	0.85	0.64	0.41	0.98	0.87	0.66	0.43	1.00	0.91	0.69	0.44	1.00	0.91	0.69	0.45
		KW	4.06	4.14	4.26	4.39	4.35	4.44	4.57	4.71	4.61	4.70	4.84	4.99	4.83	4.93	5.08	5.24	5.02	5.13	5.29	5.46	5.19	5.30	5.47	5.64
	1600	MBh	43.5	44.8	48.5	52.1	42.5	43.8	47.4	50.9	41.5	42.7	46.3	49.7	40.5	41.7	45.1	48.4	38.5	39.6	42.9	46.0	35.6	36.7	39.7	42.6
		S/T	0.85	0.76	0.57	0.37	0.88	0.79	0.60	0.38	0.90	0.81	0.61	0.39	0.93	0.83	0.63	0.41	0.97	0.86	0.65	0.42	0.98	0.87	0.66	0.42
		KW	4.03	4.11	4.23	4.36	4.32	4.41	4.54	4.68	4.50	4.61	4.75	4.88	4.72	4.82	4.97	5.12	4.93	5.01	5.16	5.30	5.03	5.17	5.34	5.51
1408	MBh	41.4	42.6	46.1	49.5	40.4	41.6	45.0	48.3	39.4	40.6	44.0	47.2	38.5	39.6	42.9	46.0	36.6	37.6	40.7	43.7	33.9	34.9	37.7	40.5	
	S/T	0.81	0.73	0.55	0.35	0.84	0.75	0.57	0.37	0.86	0.77	0.59	0.38	0.89	0.80	0.60	0.39	0.93	0.83	0.63	0.40	0.93	0.84	0.63	0.41	
	KW	3.97	4.05	4.17	4.29	4.25	4.34	4.47	4.60	4.50	4.59	4.73	4.88	4.72	4.82	4.97	5.12	4.91	5.01	5.16	5.30	5.03	5.17	5.34	5.51	
80	1792	MBh	45.6	46.6	49.8	53.3	44.6	45.6	48.7	52.0	43.5	44.5	47.5	50.8	42.5	43.4	46.4	49.5	40.3	41.2	44.0	47.1	37.4	38.2	40.8	43.6
		S/T	1.00	0.92	0.75	0.56	1.00	0.95	0.77	0.58	1.00	1.00	0.79	0.59	1.00	1.00	0.82	0.61	1.00	1.00	0.85	0.63	1.00	1.00	0.86	0.64
		KW	4.09	4.17	4.29	4.42	4.38	4.47	4.61	4.75	4.64	4.74	4.88	5.03	4.87	4.97	5.13	5.29	5.06	5.17	5.33	5.50	5.23	5.34	5.51	5.69
	1600	MBh	44.3	45.3	48.4	51.7	43.3	44.2	47.3	50.5	42.3	43.2	46.1	49.3	41.2	42.1	45.0	48.1	39.2	40.0	42.8	45.7	36.3	37.1	39.6	42.3
		S/T	0.93	0.87	0.71	0.53	0.97	0.91	0.74	0.55	0.99	0.93	0.76	0.56	1.00	0.96	0.78	0.58	1.00	0.99	0.81	0.61	1.00	1.00	0.82	0.61
		KW	4.06	4.14	4.26	4.39	4.35	4.44	4.57	4.71	4.61	4.70	4.84	5.00	4.83	4.93	5.09	5.25	5.02	5.13	5.29	5.46	5.19	5.30	5.47	5.64
1408	MBh	42.1	43.0	46.0	49.1	41.1	42.0	44.9	48.0	40.1	41.0	43.8	46.8	39.2	40.0	42.8	45.7	37.2	38.0	40.6	43.4	34.5	35.2	37.6	40.2	
	S/T	0.89	0.84	0.68	0.51	0.92	0.87	0.71	0.53	0.95	0.89	0.72	0.54	0.98	0.92	0.75	0.56	1.02	0.95	0.78	0.58	1.02	0.96	0.78	0.58	
	KW	4.00	4.08	4.20	4.32	4.29	4.37	4.50	4.64	4.54	4.63	4.77	4.92	4.76	4.86	5.00	5.16	4.95	5.05	5.21	5.37	5.11	5.21	5.38	5.55	
85	1792	MBh	46.4	47.3	49.6	52.9	45.4	46.2	48.4	51.7	44.3	45.1	47.3	50.4	43.2	44.0	46.1	49.2	41.0	41.8	43.8	46.7	38.0	38.8	40.6	43.3
		S/T	1.00	0.99	0.89	0.72	1.00	1.00	0.92	0.75	1.00	1.00	0.95	0.77	1.00	1.00	0.98	0.79	1.00	1.00	1.00	0.82	1.00	1.00	1.00	0.83
		KW	4.12	4.20	4.33	4.46	4.42	4.51	4.64	4.78	4.68	4.77	4.92	5.07	4.91	5.01	5.17	5.33	5.10	5.21	5.37	5.55	5.27	5.38	5.55	5.73
	1600	MBh	45.1	46.0	48.1	51.4	44.0	44.9	47.0	50.2	43.0	43.8	45.9	49.0	41.9	42.8	44.8	47.8	39.8	40.6	42.5	45.4	36.9	37.6	39.4	42.0
		S/T	0.98	0.94	0.85	0.69	1.00	0.98	0.88	0.72	1.00	1.00	0.90	0.73	1.00	1.00	0.93	0.76	1.00	1.00	0.97	0.79	1.00	1.00	0.98	0.79
		KW	4.09	4.17	4.29	4.42	4.38	4.47	4.61	4.75	4.64	4.74	4.88	5.03	4.87	4.97	5.13	5.29	5.06	5.17	5.33	5.50	5.23	5.34	5.51	5.69
1408	MBh	42.8	43.7	45.7	48.8	41.8	42.6	44.7	47.6	40.8	41.6	43.6	46.5	39.8	40.6	42.5	45.4	37.9	38.6	40.4	43.1	35.1	35.7	37.4	39.9	
	S/T	0.94	0.90	0.81	0.66	0.97	0.94	0.84	0.68	0.99	0.96	0.87	0.70	1.00	0.99	0.89	0.72	1.00	1.00	0.93	0.75	1.00	1.00	0.94	0.76	
	KW	4.03	4.11	4.23	4.36	4.32	4.40	4.54	4.67	4.57	4.66	4.81	4.96	4.79	4.89	5.04	5.20	4.98	5.09	5.25	5.41	5.15	5.26	5.42	5.60	

EXPANDED PERFORMANCE DATA (COOLING) - 5 Ton

Airflow IDB* CFM			Outdoor Ambient Temperature - Degrees F. Dry Bulb																							
			65				75				85				95				105				115			
			Entering Indoor Temperature - Degrees F. Wet Bulb																							
			59	63	67	71	59	63	67	71	59	63	67	71	59	63	67	71	59	63	67	71	59	63	67	71
			70	2240	MBh	57.3	59.4	65.1	-	56.0	58.0	63.6	-	54.7	56.7	62.1	-	53.3	55.3	60.6	-	50.7	52.5	57.5	-	46.9
S/T	0.76	0.64			0.44	-	0.79	0.66	0.46	-	0.81	0.68	0.47	-	0.84	0.70	0.48	-	0.87	0.73	0.50	-	0.88	0.73	0.51	-
KW	5.59	5.70			5.88	-	6.00	6.12	6.31	-	6.36	6.49	6.69	-	6.68	6.82	7.03	-	6.95	7.09	7.32	-	7.18	7.33	7.57	-
2000	MBh	55.7		57.7	63.2	-	54.4	56.3	61.7	-	53.1	55.0	60.3	-	51.8	53.7	58.8	-	49.2	51.0	55.9	-	45.6	47.2	51.7	-
	S/T	0.73		0.61	0.42	-	0.75	0.63	0.44	-	0.77	0.65	0.45	-	0.80	0.67	0.46	-	0.83	0.69	0.48	-	0.84	0.70	0.48	-
	KW	5.55		5.66	5.83	-	5.95	6.08	6.26	-	6.31	6.44	6.64	-	6.62	6.76	6.98	-	6.89	7.04	7.26	-	7.12	7.27	7.51	-
1760	MBh	52.9	54.8	60.0	-	51.6	53.5	58.6	-	50.4	52.3	57.2	-	49.2	51.0	55.9	-	46.7	48.4	53.1	-	43.3	44.9	49.2	-	
	S/T	0.70	0.58	0.40	-	0.72	0.60	0.42	-	0.74	0.62	0.43	-	0.77	0.64	0.44	-	0.79	0.66	0.46	-	0.80	0.67	0.46	-	
	KW	5.47	5.58	5.74	-	5.86	5.98	6.16	-	6.21	6.34	6.54	-	6.52	6.66	6.86	-	6.78	6.92	7.14	-	7.01	7.16	7.38	-	
75	2240	MBh	58.3	60.0	65.0	69.7	56.9	58.6	63.5	68.1	55.6	57.2	61.9	66.5	54.2	55.8	60.4	64.9	51.5	53.0	57.4	61.6	47.7	49.1	53.2	57.1
		S/T	0.87	0.78	0.59	0.38	0.90	0.80	0.61	0.39	0.92	0.82	0.62	0.40	0.95	0.85	0.64	0.41	0.99	0.88	0.67	0.43	1.00	0.89	0.67	0.43
		KW	5.64	5.75	5.92	6.10	6.05	6.17	6.36	6.56	6.41	6.54	6.75	6.96	6.73	6.87	7.09	7.32	7.00	7.15	7.38	7.62	7.24	7.39	7.63	7.88
	2000	MBh	56.6	58.3	63.1	67.7	55.3	56.9	61.6	66.1	54.0	55.6	60.1	64.5	52.7	54.2	58.7	63.0	50.0	51.5	55.7	59.8	46.3	47.7	51.6	55.4
		S/T	0.83	0.74	0.56	0.36	0.86	0.77	0.58	0.37	0.88	0.79	0.60	0.38	0.91	0.81	0.61	0.40	0.94	0.84	0.64	0.41	0.95	0.85	0.64	0.41
		KW	5.59	5.71	5.88	6.06	6.00	6.12	6.31	6.51	6.36															

STANDARD (DIRECT DRIVE) BLOWER PERFORMANCE DATA

Model Number	Motor Speed	Air Delivery in CFM * External Static Pressure (In. W.C.)					
		.20	.30	.40	.50	.60	.70
PGMF36H090 036H135 036F090	HI	1585	1535	1480	1415	1345	1265
	MD HI	1480	1440	1390	1335	1275	1200
	MD LO	1385	1350	1315	1265	1210	1140
	LO	1315	1290	1250	1205	1150	1085
PGMF48H090 048F090	HI	1880	1795	1725	1650	1570	1485
	MD HI	1735	1680	1620	1560	1485	1405
	MD LO	1540	1505	1465	1415	1350	1280
	LO	1480	1430	1395	1345	1290	1225
PGMF48H135 048F135	HI	2185	2125	2085	2010	1950	1875
	MD HI	1805	1775	1735	1690	1635	1580
	MD LO	---	---	---	---	---	---
	LO	1685	1660	1625	1585	1540	1485
PGMF60H090 060H115 060F090 060F115	HI	2250	2190	2125	2060	1990	1915
	MD HI	2090	2045	1995	1935	1875	1805
	MD LO	1650	1630	1600	1665	1525	1475
	LO	1315	1300	1280	1255	1225	1185
PGMF60H150 060F150	HI	2400	2325	2250	2170	2085	2000
	MD HI	2335	2270	2200	2125	2050	1965
	MD LO	2205	2145	2080	2015	1940	1865
	LO	2095	2040	1985	1920	1855	1780

Air delivery against shown external static pressures taken with 230V to unit, dry coil. For wet coil subtract approx. .25 CFM. Will operate at rated ESP in either horizontal or downflow duct position. * Dry coil, with filter.

UNIT DIMENSIONS

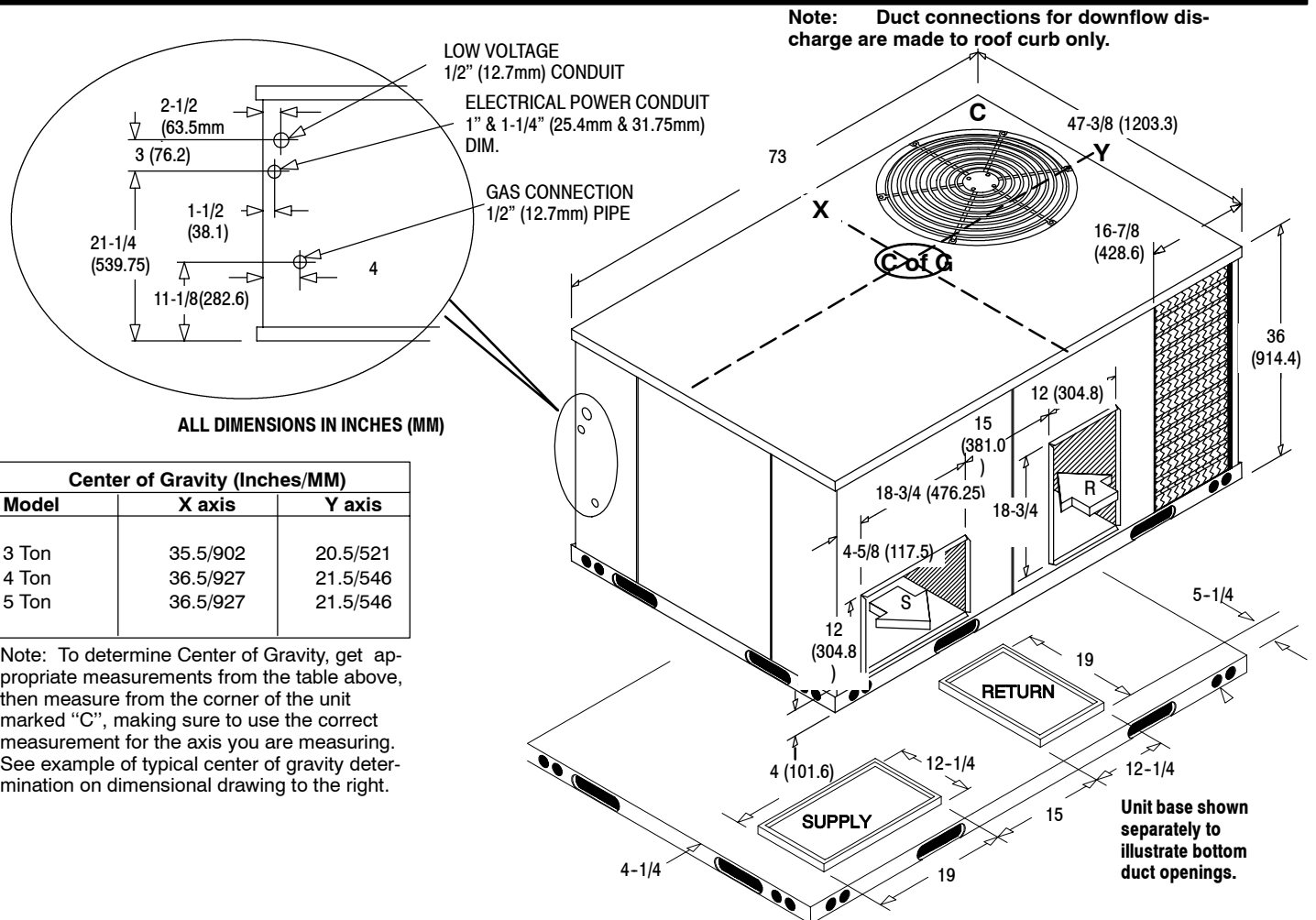

ACCESSORIES

ROOF CURB

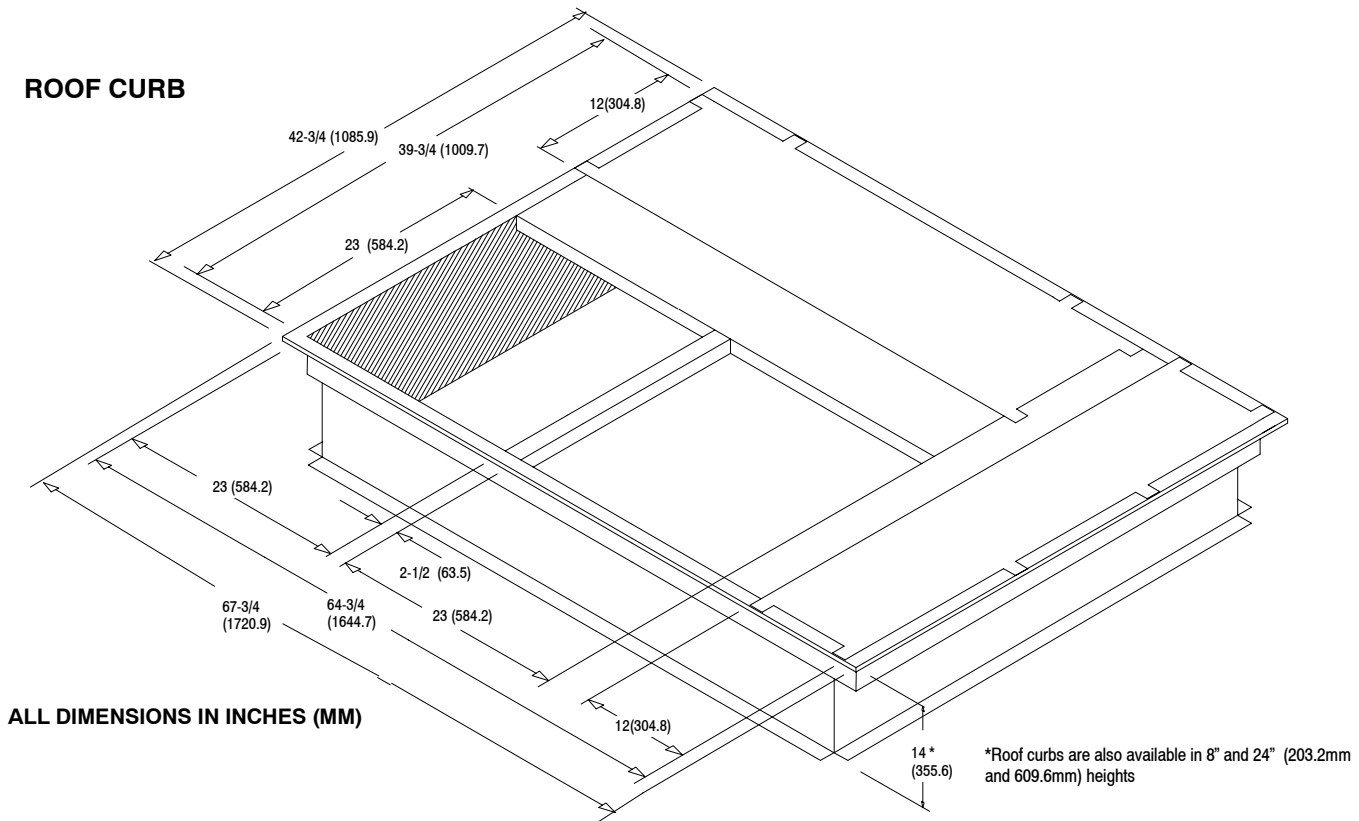

ALL DIMENSIONS IN INCHES (MM)

*Roof curbs are also available in 8" and 24" (203.2mm and 609.6mm) heights

ROOF CURBS

Description	Model Number	Used on
8"	AXB030CLA	3 to 5 Ton
14"	AXB030CMA	3 to 5 Ton
24"	AXB030CHA	3 to 5 Ton
Roof Curb Transition to Round Duct	AXB030CTA	3 to 5 Ton

FOSSIL FUEL CONVERSION

Description	Service Parts Number *	Burners	Used on Heat Input
Natural to LP Gas	1084495	4	90 MBTUH
	1084496	5	115 MBTUH
	1084497	6	135 MBTUH
	1084498	7	150 MBTUH
LP to Natural Gas	1148142	n/a	90 - 150 MBTUH

*Available through service parts only

CONCENTRIC DUCT KIT

Description	Mainline Model Number	Used on
Roof Curb Transition Square to Round	AXB030CTA	3 to 5 Ton
Grille, Flush Mount	AXB030CFA	3 to 5 Ton
Grille, Step Down	AXB030CSA	3 to 5 Ton

NATURAL GAS LOW FIRE KITS

Description	Service Parts Number *	New Low Fire Heat Input
90,000 BTUH Kit	1148135	75,000 BTUH
115,000 BTUH Kit	1148136	95,000 BTUH
135,000 BTUH Kit	1148137	110,000 BTUH
150,000 BTUH Kit	1148138	130,000 BTUH

*Available through service parts only

OUTDOOR AIR DAMPERS

Description	Model Number	Used on
Manual - 25%	AXB030FAB	3 to 5 Ton
Motorized - 25%	AXB030FMB	3 to 5 Ton

COIL PROTECTION

Description	Model Number	Used on
Coil Guard	1149486	3 to 5 Ton
Hail Guard	1068134	3 to 5 Ton

LOW AMBIENT CONTROLS

Description	Service Parts Number	Used on
To 0° F	1148233	3 to 5 Ton

*Available through service parts only

ACCESSORIES

ECONOMIZER FEATURES: DOWNFLOW AND HORIZONTAL

- Provides outdoor air ventilation, automatic free cooling when favorable outside conditions exist, with pressure relief for proper air balance on selected models.
- Interconnecting wiring furnished
- 24 volt system
- Center mounted, dual action, dampers with gasketing ensure proper seal.
- Barometric pressure relief damper is standard on some models.
- Enthalpy controls on selected models.

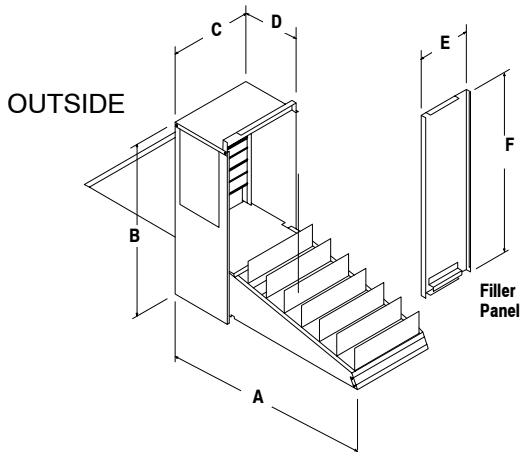

Modulating & Three Position Economizers

ECONOMIZERS - DOWNFLOW

Description	Model Number	Used on
Fully Modulating	AXB030EMB *1	3 to 5 Ton
Three Position	AXB030EPD *2	3 to 5 Ton
Three Position (Entry Level)	AXB030ECA *3	3 to 5 Ton

* 1 - Ambient/Enthalpy Control; Includes Return Air Damper & Relief Damper.

* 2 - Ambient Control Only; Includes Return Air Damper & Relief Damper.

* 3 - Ambient Control Only; No Return Air Damper; No Relief Damper.

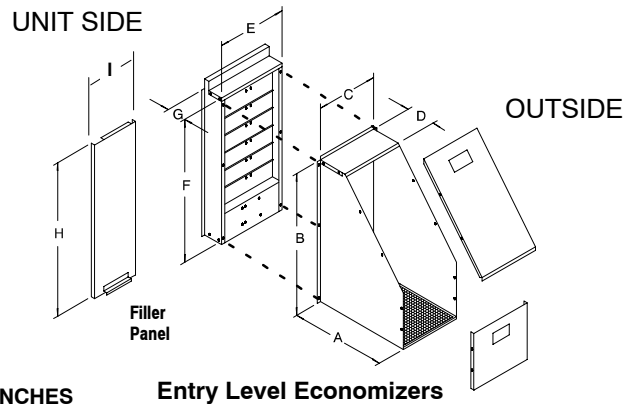

Entry Level Economizers

ALL DIMENSIONS IN INCHES

80-00-54

Economizer Model No.	A	B	C	D	E	F
AXB030E**	35	31	14-3/4	10-7/8	9-3/8	32-1/2

Economizer Model No.	A	B	C	D	E	F	G	H	I
AXB030ECA	20 ¹ / ₄	30	13	6	12 ³ / ₄	31	4 ¹ / ₈	32 ¹ / ₂	9-3/8

ECONOMIZERS - HORIZONTAL

Description	Model Number	Used on
Fully Modulating	AXB030HEB *1	3 to 5 Ton
Three Position	AXB030HPD *2	3 to 5 Ton

* 1 - Ambient/Enthalpy Control; Includes Return Air Damper & Relief Damper.

* 2 - Ambient Control Only; Includes Return Air Damper & Relief Damper.

Economizer Model No.	A	B	C	D	E
AXB030H**	9-3/4	4	6	18-3/4	1

ALL DIMENSIONS IN INCHES

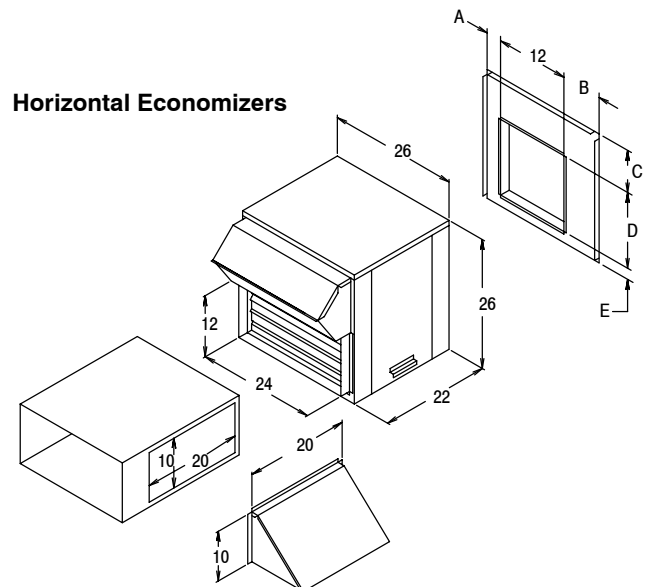

Horizontal Economizers

SPECIFICATIONS SUBJECT TO CHANGE WITHOUT NOTICE

GUIDE SPECIFICATION

CABINET

The cabinet is made of sturdy G-90 galvanized steel, phosphate coated with a tough acrylic finish. Base rails are 18 gauge steel with fork lift slots and holes provided for lifting shackles. Unit is designed for convertible airflow and is shipped ready for downflow application. Conversion to horizontal airflow is accomplished by relocating two panels.

Return air compartments are insulated with 1" (25.4mm) of water resistant coated glass fiber and 1" (25.4mm) of aluminum foil faced glass fiber in the furnace/supply compartments.

COOLING SECTION

Units are factory charged and operationally ready. Each refrigerant circuit has a compressor with internal overload protection, high and low pressure switches, filter drier, and copper tube/aluminum fin evaporator and condenser coils.

Units are capable of cooling operation down to 40°F (17.4°C) as shipped from the factory.

COILS

The evaporator and condenser coils are fabricated with aluminum fins mechanically bonded to copper tubing. Both coils are pressure tested prior to assembly into the unit and electronically leak tested after assembly into the unit. The evaporator coil is protected from dust and debris on the return air side by factory installed 2" (50.8mm) air filters.

CONDENSER FAN

The unit has a single direct drive propeller fan/motor assembly mounted directly to a vertical-discharge grille panel that is easily removable. Motors are 1075 RPM with permanently lubricated sleeve bearings and inherent overload protection.

EVAPORATOR BLOWER

The standard direct drive blower for the 3 to 5 ton has the motor mounted inside a single, double inlet centrifugal wheel and has internal overload protection and permanently lubricated ball bearings or sleeve bearings with oilers. The evaporator blower system has the capability to operate against the same rated external static pressure in downflow or horizontal duct designs.

HEATING SECTION

The units have aluminized steel tubular heat exchangers located on the discharge side of the evaporator blower with a single stage gas valve. The units have in-shot burners that are ignited by an electronic hot surface pilot with flame proving feature and protected by both a limit switch and flame roll-out switch. The induced draft blower motor is interlocked with a proven air pressure safety device.

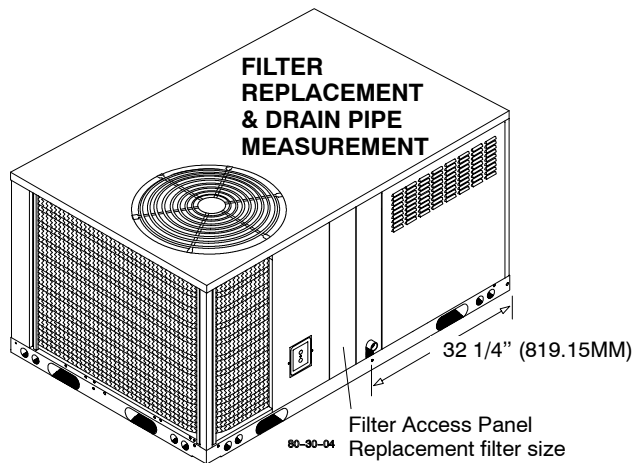

FILTER REPLACEMENT & DRAIN PIPE MEASUREMENT

32 1/4" (819.15MM)

Filter Access Panel
Replacement filter size
20" X 30" X 2".
(508mm x 762mm x 50.8mm)
Requires two.

RIGGING DETAILS

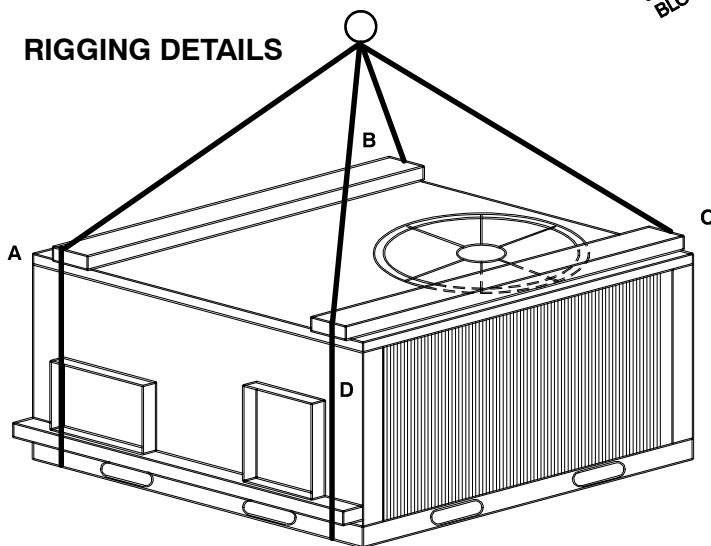

INSTALLATION CLEARANCES

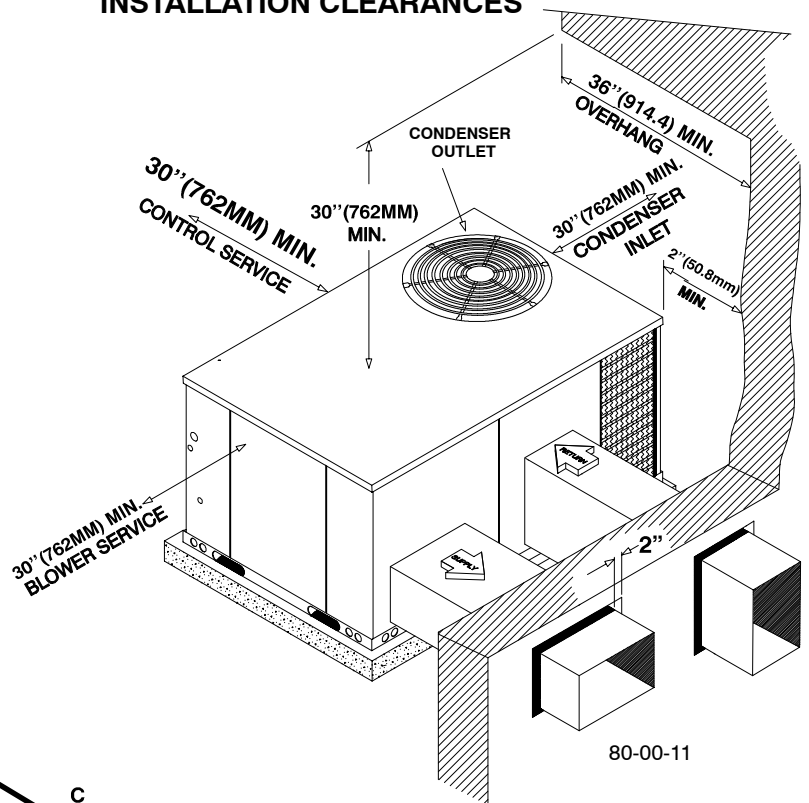

80-00-11

CORNER WEIGHTS (LBS/KGS)

MODEL	A	B	C	D	OPERATING WEIGHT TOTAL
3 Ton	122/55.3	163/74.0	172/78.0	129/58.5	586/265.8
4 Ton	137/62.1	169/76.7	169/76.7	137/62.1	612/277.6
5 Ton	141/64.0	173/78.5	173/78.5	141/64.0	628/284.9