

HIGH EFFICIENCY PACKAGE ELECTRIC COOLING, R-410A SINGLE PACKAGE ROOFTOP 15 – 25 TONS

BUILT TO LAST, EASY TO INSTALL AND SERVICE

- One-piece, high efficiency electric cooling with a low profile, prewired, tested, and charged at the factory
- Dedicated vertical or horizontal air flow duct configuration models. No field kits required.
- Full perimeter base rail with built-in rigging adapters and fork truck slots
- Pre-painted exterior panels and primer-coated interior panels tested to 500 hours salt spray protection
- Fully insulated cabinet
- Two-stage cooling with independent circuits and control on all models
- Scroll compressors on all models
- All units have high and low pressure switches
- Two inch disposable fiberglass type return air filters in dedicated rack with tool-less filter access door
- Refrigerant circuits contain a liquid line filter drier to trap dirt and moisture
- Exclusive non-corrosive composite condensate pan in accordance with ASHRAE 62 Standard, sloping design; end drain
- Belt drive evaporator-fan motor and pulley combinations available to meet most applications
- Access panels with easy grip handles provide quick and easy access to the blower and blower motor, control box, and compressors.
- “No-strip” screw system has superior holding power and guides screws into position while preventing the screw from stripping the unit’s metal.
- Newly designed terminal board facilitates simple safety circuit troubleshooting and simplified control box arrangement
- Standard outdoor temperature cooling operation range up to 125°F (52°C) and down to 35°F (2°C)
- TXV metering devices on all models to precisely control refrigerant flow
- Large, laminated control wiring and power wiring drawings are affixed to unit to make troubleshooting easy
- Capable of thru-the-base or thru-the-curb electrical routing
- Full range of electric heaters and single point electrical connections

WARRANTY

- 5 Year compressor limited warranty
- 1 Year parts limited warranty



15 Ton



As an Energy Star® Partner, International Comfort Products has determined that this product meets the ENERGY STAR® guidelines for energy efficiency.



Use of the AHRI Certified TM Mark indicates a manufacturer’s participation in the program. For verification of certification for individual products, go to www.ahridirectory.org.



UNIT PERFORMANCE DATA – Two Stage Cooling								
UNIT	Dedicated Airflow	Nominal Tons	COOLING			Total Power (kW)	Unit Dimensions H x W x L	Unit Weight lb. [kg]
			Net Cap. (Btuh)	EER	IEER			
RAH181*0AA0AAA	Vertical	15	174,000	12.2	13.2	14.3	49-3/8" x 86-3/8" x 127-7/8"	1793 [815]
RAH183*0AA0AAA	Horizontal	15	174,000	12.2	13.2	14.3	49-3/8" x 86-3/8" x 127-7/8"	1793 [815]
RAH210*0AA0AAA	Vertical	17.5	202,000	12.2	13.2	16.6	49-3/8" x 86-3/8" x 141-1/2"	2003 [911]
RAH213*0AA0AAA	Horizontal	17.5	202,000	12.2	13.2	16.6	49-3/8" x 86-3/8" x 141-1/2"	2003 [911]
RAH240*0AA0AAA	Vertical	20	236,000	12.2	13.4	19.3	57-3/8" x 86-3/8" x 141-1/2"	2148 [976]
RAH243*0AA0AAA	Horizontal	20	236,000	12.2	13.4	19.3	57-3/8" x 86-3/8" x 141-1/2"	2148 [976]
RAH300*0AA0AAA	Vertical	25	282,000	11.4	12.2	25.2	57-3/8" x 86-3/8" x 157-3/4"	2193 [997]
RAH303*0AA0AAA	Horizontal	25	282,000	11.4	12.2	25.2	57-3/8" x 86-3/8" x 157-3/4"	2193 [997]

* Indicates Unit voltage: H = 208/230-3-60, L = 460-3-60, S = 575-3-60

NOTE: BASE MODEL NUMBERS LISTED. SEE MODEL NOMENCLATURE LISTING FOR ADDITIONAL OPTIONS

TABLE OF CONTENTS

	PAGE		PAGE
MODEL NUMBER NOMENCLATURE	3	ELECTRICAL DATA FOR UNITS PRODUCED ON OR AFTER JULY 30, 2012	40
FACTORY OPTIONS AND/OR ACCESSORIES	4	ELECTRICAL INFO	41
AHRI COOLING RATING TABLE	10	WIRE/FUSE OR HACR BREAKER SIZING	51
SOUND PERFORMANCE TABLE	10	ELECTRICAL DATA FOR UNITS PRODUCED PRIOR TO JULY 30, 2012	63
PHYSICAL DATA	11	ELECTRICAL INFO	64
CURBS & WEIGHTS DIMENSIONS	13	WIRE/FUSE OR HACR BREAKER SIZING	74
APPLICATION DATA	23	SEQUENCE OF OPERATION	82
COOLING TABLES	24	DIAGRAMS FOR HOT GAS REHEAT	83
STATIC PRESSURE ADDERS	32	GUIDE SPECIFICATIONS	84
OUTDOOR AIR INTAKE & EXHAUST PERF	33		
FAN PERFORMANCE	34-35		

15 to 25 TON ROOFTOP UNIT FIOP CODES (Use with Model Nomenclature on next page)			
OPTION	DESCRIPTION	NOMENCLATURE	
		CODE	OPTIONS
2	Non-Fused Disconnect Switch	0A	None
4	Easy Access Hinged Panels	4B	2
5	Unpowered Convenience Outlet	7C	2, 5
9	Supply Air Smoke Detector	7K	2,5,9
		8A	2, 9
		AT	5
		BA	5, 9
		AA	4
		6C	2, 4
		6D	2, 4, 5
		6L	2, 4, 5, 9
		7B	2, 4, 9
		AB	4, 5
		AJ	4, 5, 9
		CH	4, 9
		BR	9

MODEL NOMENCLATURE

MODEL SERIES	R	A	H	1	8	1	H	0	A	A	0	A	A	A
Position Number	1	2	3	4	5	6	7	8	9	10	11	12	13	14
R = Rooftop														
A = Air Conditioning Type														
H = High Efficiency Efficiency														
181 = 181,000 = 15 Tons Dedicated Vertical SA/RA (SA = Supply Air, RA = Return Air) 183 = 180,000 = 15 Tons Dedicated Horizontal SA/RA 210 = 210,000 = 17.5 Tons Dedicated Vertical SA/RA 213 = 210,000 = 17.5 Tons Dedicated Horizontal SA/RA 240 = 240,000 = 20 Tons Dedicated Vertical SA/RA 243 = 240,000 = 20 Tons Dedicated Horizontal SA/RA 300 = 300,000 = 25 Tons Dedicated Vertical SA/RA 303 = 300,000 = 25 Tons Dedicated Horizontal SA/RA <div style="text-align: right;">Nominal Cooling Capacity</div>														
H = 208/230-3-60 L = 460-3-60 S = 575-3-60 <div style="text-align: right;">Voltage</div>														
0 = No Heat <div style="text-align: right;">Heating Capacity</div>														
A = Standard Motor (All sizes) C = Medium Static Motor (15 & 17.5 ton with 1 speed IFM, All sizes with 2 speed IFM) B = High Static Motor (15 ton with 1 speed IFM, All sizes with 2 speed IFM) E = High Static - High Efficiency Motor (17.5 to 25 ton with 1 speed IFM) F = Medium Static - High Efficiency Motor (20 & 25 ton with 1 speed IFM) G = High Static Motor with Hot Gas Reheat (All sizes) <div style="text-align: right;">Motor Option</div>														
A = None B = Economizer w/Bara-relief, OA Temp sensor E = Economizer w/Bara-relief + CO ₂ sensor, OA Temp sensor H = Economizer w/Bara-relief, Enthalpy sensor L = Economizer w/Bara-relief + CO ₂ sensor, Enthalpy sensor U = Ultra Low Leak Temp Economizer w/Baro relief W = Ultra Low Leak Enthalpy Economizer w/Baro relief P = 2-Position damper w/Baro-relief <div style="text-align: right;">Outdoor Air Options / Control</div>														
0A = No Options 4B = Non-Fused Disconnect AT = Non-powered 115v C.O. BR = Supply Air Smoke Detector AA = Easy Access Hinged Panels <div style="text-align: right;">Factory Installed Options</div>														
A = Aluminum/Copper Cond & Evap Coil B = Precoat Aluminum/Copper Cond & Alum/Copper Evap Coil C = E-Coated Aluminum/Copper Cond & Alum/Copper Evap Coil D = E-Coated Aluminum/Copper Cond & E-Coated Aluminum/Copper Cond Evap Coil E = Copper/Copper Cond & Aluminum/Copper Evap F = Copper/Copper Cond & Copper/Copper Evap <div style="text-align: right;">Condenser / Evaporator Coil Configuration</div>														
A = Standard Motor T = 2-Speed Indoor Fan VFD Controller (For 2-stage units only) <div style="text-align: right;">Motor Type Option</div>														

TABLE 1 – FACTORY INSTALLED OPTIONS AND FIELD INSTALLED ACCESSORIES

CATEGORY	ITEM	FACTORY INSTALLED OPTION	FIELD INSTALLED ACCESSORY
Cabinet	Dedicated Vertical Air Flow Duct Configuration	X	
	Dedicated Horizontal Air Flow Duct Configuration	X	
Coil Options	Cu/Cu (indoor) Coils	X	
	Pre-Coat (outdoor) Coils	X	
	E-coated (outdoor & indoor) coils	X	
Humidity Control	Hot Gas Reheat	X	
Condenser Protection	Condenser coil hail guard (louvered design)		X
Controls	Smoke detector (supply air)	X	X
	Time Guard II compressor delay control circuit		X
	Phase Monitor		X
Economizers & Outdoor Air Dampers	Economizer IV	X	X
	Motorized 2 position outdoor-air damper	X	X
	Manual outdoor-air damper (25%)		X
	Barometric relief ¹	X	X
	Barometric hood (Horizontal economizer)		X
	Power exhaust-centrifugal blower		X
	Ultra Low Leak Economizer X (for 2-Speed Indoor Fan Motor System only, 15 to 25 sizes with 2 stages of cooling), vertical supply and return air only.	X	X
Economizer Sensors & IAQ Devices	Single dry bulb temperature sensors ²	X	X
	Single enthalpy sensors ²	X	X
	Differential enthalpy sensors ²		X
	Duct mounted CO ₂ sensor ²		X
	4-in Filter Track Assembly		X
Heat	Electric Heat (Vertical or Horizontal Duct Configuration)		X
	Single Point Kit		X
Indoor Motor & Drive	Multiple motor and drive packages	X	
	2-Speed Indoor Fan Motor System w/VFD controller (2-stage cool only with electrical mechanical controls)	X	
Low Ambient Control	Winter start kit ³		X
	Motormaster head pressure controller ³		X
Power Options	Convenience outlet (unpowered)	X	
	Non-fused disconnect ⁴	X	
Roof Curbs	Roof curb 14-in (356mm)		X
	Roof curb 24-in (610mm)		X

NOTES:

1. Included with economizer.
2. Sensors used to optimize economizer performance.
3. See application data for assistance.
4. Non-fused disconnect switch cannot be used when MOCP electrical rating exceeds 70 amps at 460/575 volt and 150 amps at 208/230 volt.

FACTORY OPTIONS AND/OR ACCESSORIES

Economizer (dry–bulb or enthalpy)

Economizers save money. They bring in fresh, outside air for ventilation; and provide cool, outside air to cool your building. This is the preferred method of low–ambient cooling. When coupled to CO₂ sensors, economizers can provide even more savings by coupling the ventilation air to only that amount required.

Economizers are available, installed and tested by the factory, with either enthalpy or dry–bulb temperature inputs. Additional sensors are available as accessories to optimize the economizers.

Economizers include gravity controlled, barometric relief equalizes building pressure and ambient air pressures. This can be a cast effective solution to prevent building pressurization. If further control of exhaust air is required, a dual centrifugal fan power exhaust system is also available.

CO₂ Sensor

Improves productivity and saves money by working with the economizer to intake only the correct amount of outside air for ventilation. As occupants fill your building, the CO₂ sensor detects their presence through increasing CO₂ levels, and opens the economizer appropriately.

When the occupants leave, the CO₂ levels decrease, and the sensor appropriately closes the economizer. This intelligent control of the ventilation air, called Demand Control Ventilation (DCV) reduces the overall load on the rooftop.

Smoke Detector

Smoke detectors make your application safer and your job easier. Smoke detectors immediately shut down the rooftop unit when smoke is detected. It is available for supply air.

Louvered Hail Guards (accessory only)

Sleek, louvered panels protect the condenser coil from hail damage, foreign objects, and incidental contact.

Convenience Outlet (un–powered)

Reduce service and/or installation costs by including a convenience outlet in your specification. The convenience outlet provides a 15 amp, 115v GFCI receptacle with “Wet in Use” cover. This option is to be powered from a separate 115/120v power source.

Non–Fused Disconnect

This OSHA–compliant, factory–installed, safety switch allows a service technician to locally secure power to the rooftop capable of providing protection to a MOCP maximum of 200A.

Power Exhaust with Barometric Relief

Superior internal building pressure control. This field–installed accessory may eliminate the need for costly, external pressure control fans.

Time Guard II Control Circuit

This accessory protects your compressor by preventing short–cycling in the event of some other failure, prevents the compressor from restarting for 30 seconds after stopping.

Motorized 2–Position Damper

The new 2–position, motorized outdoor air damper admits up to 100% outside air. Using reliable, gear–driven technology, the 2–position damper opens to allow ventilation air and closes when the rooftop stops, stopping unwanted infiltration.

Manual OA Damper (accessory only)

Manual outdoor air dampers are an economical way to bring in ventilation air. The dampers are available in 25% versions.

Motormaster Head Pressure Controller

The Motormaster motor controller is a low ambient, head pressure controller kit that is designed to maintain the unit's condenser head pressure during periods of low ambient cooling operation. This device should be used as an alternative to economizer free cooling not when economizer usage is either not appropriate or desired. The Motormaster will either cycle the outdoor–fan motors or operate them at reduced speed to maintain the unit operation, depending on the model.

Winter Start Kit (accessory only)

The winter start kit extends the low ambient limit of your rooftop to 25°F (–4°C). The kit bypasses the low pressure switch, preventing nuisance tripping of the low pressure switch. Other low ambient precautions may still be prudent.

High Static Motors and Drives

Some applications need larger horsepower motors, some need more airflow, and some need both. Regardless of the case, your dealer has a factory installed combination to meet your application. A wide selection of motors and pulleys (drives) are available, factory installed, to handle nearly any application.

Filter or Fan Status Switches

Use these differential pressure switches to detect a filter clog or indoor fan motor failure. When used in conjunction with a compatible unit controller/thermostat, the switches will activate an alarm to warn the appropriate personnel.

Electric Heaters / Single Point Kit

A full–line of field–installed accessory heaters and single point kits are available when required. The heaters are very easy to use, install and are all pre–engineered and certified.

Barometric Hood (accessory only)

For Horizontal Economizer applications where relief damper is installed in duct work. This kit provides the needed protection.

FACTORY OPTIONS AND/OR ACCESSORIES (CONT.)

Hot Gas Reheat System

Hot Gas Reheat is an all-inclusive factory installed option that can be ordered with RAH units.

This system expands the envelope of operation of rooftop products to provide unprecedented flexibility to meet year round comfort conditions.

The Hot Gas Reheat has the industry's only dual dehumidification mode setting. The Hot Gas Reheat System includes two new modes of operation.

RAH rooftop units coupled with the Hot Gas Reheat is capable of operating in normal design cooling mode, subcooling mode, and hot gas reheat mode. Normal design cooling mode is when the unit will operate under its normal sequence of operation by cycling compressors to maintain comfort conditions.

Subcooling mode will operate to satisfy part load type conditions when the space requires combined sensible and a higher proportion of latent load control. Hot Gas Reheat mode will operate when outdoor temperatures diminish and the need for latent capacity is required for sole humidity control. Hot Gas Reheat mode will provide neutral air for maximum dehumidification operation.

2-Speed Indoor Fan Motor System

The 2-Speed Indoor Fan Motor System saves energy and installation time by utilizing a Variable Frequency Drive (VFD) to automatically adjust the indoor fan motor speed in sequence with the units cooling operation. Per ASHRAE 90.1 2010 standard section 6.4.3.10.b, during the first stage of cooling operation the VFD will adjust the fan motor to provide 2/3rd of the total cfm established for the unit. When a call for the second stage of cooling is required, the VFD will allow the total cfm for the unit established (100%). During the heating mode the VFD will allow total design cfm (100%) operation and during the ventilation mode the VFD will allow operation to 2/3rd of total cfm.

Compared to single speed indoor fan motor systems, the 2-Speed Indoor Fan Motor System can save substantial energy, 25%+*, versus single speed indoor fan motor systems.

The VFD used in the 2-Speed Indoor Fan Motor System has soft start capabilities to slowly ramp up the speeds, thus eliminating any high inrush air volume during initial start-up. It also has internal over current protection for the fan motor and a field installed display kit that allows adjustment and in depth diagnostics of the VFD.

This 2-Speed Indoor Fan Motor System is available on models with 2-stage cooling operation with electrical mechanical or RTU Open, Multi Protocol controls. Both space sensor and conventional thermostats controls can be used to provide accurate control in any application.

The 2-Speed Indoor Fan Motor System is very flexible for initial fan performance set up and adjustment. The standard factory shipped VFD is pre-programmed to automatically stage the fan speed between the first and second stage of cooling. The unit fan performance static pressure and cfm can be easily adjusted using the traditional means of pulley adjustments. The other means to adjust the unit static and cfm performance is to utilize the field installed Display Kit and adjust the frequency and voltage in the VFD to required performance requirements. In either case, once set up, the VFD will automatically adjust the speed between the cooling stage operations.

ACCESSORIES – RAH181–303

ECONOMIZER IV		
Model Number	Description	Use With Model Size
DNECOMZR052A00 ¹²	Vertical and Horizontal Economizer IV with solid-state controller, gear-driven, modulating damper, spring return actuator, up to 100% barometric relief, supply and outdoor air sensors and outdoor air hood. CO2 sensor compatible	181/183 – 210/213
DNECOMZR053A00 ¹²		240/243 – 300/303

¹ Economizer IV cannot be installed with an Economizer X, Manual Damper or Motorized Damper or any other DDC controller models.

² Barometric relief must be installed in return ductwork on Horizontal configured models (213, 243, 303 & 333)

ECONOMIZER X		
Model Number	Description	Use With Model Size
DNECOMZR074A00 ¹²	Ultra LOW LEAK – Vertical Economizer X with solidstate W7220 controller, gear-driven, modulating damper, spring return actuator, up to 100% barometric relief, supply and outdoor air sensors, and CO2 sensor compatible, for use in electro mechanical controls only.	181/183 – 210/213
DNECOMZR075A00 ¹²		240/243 – 300/303

¹ Economize rX cannot be installed with an Economizer IV, Manual Damper or Motorized Damper or any other DDC controller models.

² Can only be used on electrical mechanical units with 2 stage cooling and 2 speed fan control.

ECONOMIZER SENSORS		
Model Number	Description	Use With Model Size
DNTEMPSN002A00	Single (dry bulb) Control	Economizer IV
DNCBDIOX005A00	CO2 Sensor and aspirator box for use in return airstream.	Economizer IV, X
DNENTDIF004A00	Return Air Enthalpy Sensor	Economizer IV
AXB078ENT	Enthalpy Control	Economizer IV
CRTEMPSN005A00	Outdoor or Return Dry Bulb Temp Sensor	Economizer X
HH57AC081	Enthalpy control (One required for single enthalpy, two for differential)	Economizer X

BAROMETRIC RELIEF HOOD		
Model Number	Description	Use With Model Size
CRBARHOD001A00	For horizontal economizer applications where relief damper is installed in duct work, this kit provides needed protection	183 – 213 – 243 – 303

POWER EXHAUST*		
Model Number	Description	Use With Model Size
CRPWREXH068A00	Vertical and Horizontal, 208/230–3–60	181/183–210/213–240/243–300/303
CRPWREXH069A00	Vertical and Horizontal, 460–3–60	181/183–210/213–240/243–300/303
CRPWREXH070A00	Vertical and Horizontal, 575–3–60	181/183–210/213–240/243–300/303

* When power exhaust is used on horizontal applications, it must be field mounted to the side of the return duct.

MANUAL OUTDOOR AIR DAMPERS		
Model Number	Description	Use With Model Size
CRMANDPR009A00	25% Open Manual Fresh Air Damper	181/183 – 210/213
CRMANDPR010A00	25% Open Manual Fresh Air Damper	240/243 – 300/303

MOTORIZED OUTDOOR AIR DAMPERS		
Model Number	Description	Use With Model Size
CRTWOPOS012A00	Motorized 2 position outdoor air damper	181/183 – 210/213
CRTWOPOS013A00	Motorized 2 position outdoor air damper	240/243 – 300/303

FLAT ROOF CURBS		
Model Number	Description	Use With Model Size
CRRFCURB045A00	14" High Roof Curb – .14-inch Tall Roof Curb. Complies with NRCA standards. Ductwork attaches to the roof curb. Includes thru-the -bottom capability.	181/183
CRRFCURB047A00		210/213 – 240/243
CRRFCURB046A00	24" High Roof Curb – 24-inch Tall Roof Curb. Complies with NRCA standards. Ductwork attaches to the roof curb. Includes thru-the -bottom capability.	181/183
CRRFCURB048A00		210/213 – 240/243
CRRFCURB049A00	14" High Roof Curb – 14-inch Tall Roof Curb. Complies with NRCA standards. Ductwork attaches to the roof curb. Includes thru-the -bottom capability.	300/303
CRRFCURB050A00	24" High Roof Curb – 24-inch Tall Roof Curb. Complies with NRCA standards. Ductwork attaches to the roof curb. Includes thru-the -bottom capability.	300/303

ACCESSORIES – RAH181–303 (cont.)

LOW AMBIENT CONTROLS		
Model Number	Description	Use With Model Size
CRLOWAMB041A00	Motormaster I –20° Low Ambient Control 208/230–3–60	181/183–210/213–240/243–300/303
CRLOWAMB042A00	Motormaster I –20° Low Ambient Control 460–3–60, 575–3–60	181/183–210/213–240/243–300/303
CRTRXKIT001A00	Motormaster I –20° Transformer 575–3–60 ¹	181/183–210/213–240/243–300/303
LOUVERED HAIL GUARDS		
Model Number	Description	Use With Model Size
CRLVHLGD017A00	Louvered Condenser Coil Hail Guard	181/183
CRLVHLGD030A00	Louvered Condenser Coil Hail Guard	210/213
CRLVHLGD031A00	Louvered Condenser Coil Hail Guard	240/243
CRLVHLGD029A00	Louvered Condenser Coil Hail Guard	300/303
CONTROL UPGRADE KITS		
Model Number	Description	Use With Model Size
CRDISKIT001A00	2-Speed VFD display kit provides the field capability to set up points and troubleshooting codes on the VFD controller. Can be used for any associated unit with VFD.	All 2-Speed VFD Controllers
CRPHASE3001A02	Electronic Phase Monitor – All 208/230/460–3–60 models	181/183–240/243–300/303–336/333
CRPHASE3002A00	Electronic Phase Monitor – All 575–3–60 models	181/183–240/243–300/303–336/333
CRSTATUS005A00	Fan/filter Status Switch – Indicator light not included	181/183–240/243–300/303–336/333
NRTIMEGD001A00	Time Guard II	181/183–240/243–300/303–336/333
CRSDTEST001A00	Smoke detector remote Test/Reset/Alarm indicator kit	181/183–240/243–300/303–336/333
CRSMKSEN002A00	Smoke Detector Control Module	181/183–240/243–300/303–336/333
CRSMKKIT002A00	Smoke Detector Control Module (Smoke Detector Sensor with sampling tube & exhaust tube)	181/183–240/243–300/303–336/333
DNWINSTR001A00	Winter Start Kit – Contains time delay relay for timed bypass of low pressure switch on start-up	181/183–240/243–300/303–336/333
4" FILTER TRACK UPGRADE KIT		
Model Number	Description	Use With Model Size
CRFLTTRK001A00	4" Field Conversion Kit	181 – 303

ACCESSORIES – RAH181–303 (cont.)

ELECTRIC HEAT – HORIZONTAL DUCT CONFIGURATION		
Model Number	Nominal kW	Use With Model Size
CRHEATER270A00	25.0	All Horizontal Duct 208/230v Models
CRHEATER271A00	50.0	
CRHEATER272A00	75.0	
CRHEATER273A00	25.0	All Horizontal Duct 460v Models
CRHEATER274A00	50.0	
CRHEATER275A00	75.0	
CRHEATER276A00	24.8	All Horizontal Duct 575v Models
CRHEATER277A00	49.6	
CRHEATER278A00	74.4	
ELECTRIC HEAT – VERTICAL DUCT CONFIGURATION		
Model Number	Nominal kW	Use With Model Size
CRHEATER279A00	25.0	All Vertical Duct 208/230v Models
CRHEATER280A00	50.0	
CRHEATER281A00	75.0	
CRHEATER282A00	25.0	All Vertical Duct 460v Models
CRHEATER283A00	50.0	
CRHEATER284A00	75.0	
CRHEATER285A00	24.8	All Vertical Duct 575v Models
CRHEATER286A00	49.6	
CRHEATER287A00	74.4	
SINGLE POINT CONNECTION KIT		
Model Number	Description	Use With Electric Heater
CRSINGLE056A00	Single Point Connection for 208/230V 75kW Heaters	CRHEATER272A00 CRHEATER281A00
CRSINGLE057A00	Single Point Connection for 460V & 575V 75kW Heaters	CRHEATER275A00 CRHEATER278A00 CRHEATER284A00 CRHEATER287A00

TABLE 2 – AHRI COOLING RATING TABLE 2-STAGE COOLING

MODEL RAH	COOLING STAGES	NOMINAL CAPACITY (TONS)	NET COOLING CAPACITY (MBH)	TOTAL POWER (kW)	EER	IEER WITH 1 SPEED IFM	IEER WITH 2 SPEED IFM
181 – 183	2	15	174.0	14.3	12.2	13.2	13.7
210 – 213	2	17.5	202.0	16.6	12.2	13.2	13.8
240 – 243	2	20	236.0	19.3	12.2	13.4	14.0
300 – 303	2	25	282.0	24.7	11.4	12.2	12.7

LEGEND

- AHRI – Air-Conditioning & Refrigeration Institute
- ASHRAE – American Society of Heating, Refrigerating and Air Conditioning, Inc.
- IEER – Integrated Energy Efficiency Ratio
- IPLV – Integrated Part Load Value

NOTES:

1. Rated and certified under AHRI Standard 340/360-04, as appropriate.
2. Ratings are based on:
Cooling Standard: 80°F (27°C) db, 67°F (19°C) wb indoor air temp and 95°F (35°C) db outdoor air temp.
IEER Standard: A measure that expresses cooling part-load EER efficiency for commercial unitary air conditioning and heat pump equipment on the basis of weighted operation at various load capacities.
3. All RAH units comply with ASHRAE 90.1 2001, 2004 Energy Standard for minimum SEER and EER requirements.
4. RAH units comply with US Energy Policy Act (2005). To evaluate code compliance requirements, refer to state and local codes or visit the following website: <http://bcap-energy.org> to determine if compliance with this standard pertains to your state, territory, or municipality.



As an Energy Star® Partner, International Comfort Products has determined that this product meets the ENERGY STAR® guidelines for energy efficiency.



Use of the AHRI Certified TM Mark indicates a manufacturer's participation in the program. For verification of certification for individual products, go to www.ahridirectory.org.



TABLE 3 – MINIMUM – MAXIMUM AIRFLOWS ELECTRIC HEAT

MODEL RAH	NOMINAL kW	ELECTRIC HEATERS		COOLING			
		MINIMUM	MAXIMUM	Minimum Single Speed Fan Motor	Minimum 2-speed Fan Motor (at high speed)	Minimum 2-speed Fan Motor (at low speed)	Maximum
181 – 183	25	4500	7500	4500	5070	3346	7500
	50						
	75						
210 – 213	25	5200	9000	5250	5915	3904	9000
	50						
	75						
240 – 243	25	6000	10000	6000	7500	4950	10000
	50						
	75						
300 – 303	25	7000	12500	7500	8450	5577	12500
	50						
	75						

TABLE 4 – SOUND PERFORMANCE TABLE

MODEL RAH	COOLING STAGES	Outdoor Sound (dB)									
		A-Wtg.	AHRI 370 Rating	63	125	250	500	1000	2000	4000	8000
181 – 183	2	84.1	84	92.2	83.9	80.4	81.8	78.7	76.5	72.2	65.4
210 – 213	2	84.1	84	92.2	83.9	80.4	81.8	78.7	76.5	72.2	65.4
240 – 243	2	86.5	87	95.6	87.5	84.2	84.2	81.7	77.9	73.2	66.3
300 – 303	2	85.9	86	97.1	88.3	84.4	83.3	80.7	77.4	73.4	67.3

LEGEND

dB – Decibel

NOTES:

1. Outdoor sound data is measured in accordance with AHRI standard 270-2008.
2. Measurements are expressed in terms of sound power. Do not compare these values to sound pressure values because sound pressure depends on specific environmental factors which normally do not match individual applications. Sound power values are independent of the environment and therefore more accurate.

3. A-weighted sound ratings filter out very high and very low frequencies, to better approximate the response of "average" human ear. A-weighted measurements are taken in accordance with AHRI standard 270-2008.

TABLE 5 – PHYSICAL DATA (COOLING) 15 – 25 TONS



RAH		181 – 183	210 – 213	240 – 243	300 – 303
Refrigeration System					
# Circuits / # Comp. / Type		2 / 2 / Scroll	2 / 2 / Scroll	2 / 2 / Scroll	2 / 2 / Scroll
R-410a charge circuit A/B (lbs)		17/16.4	17.5/16.8	23.8/23.1	24.9/27.7
Hot Gas Reheat R-410a charge circuit A/B (lbs)		24.5/25.7	25.5/25.5	30.0/30.7	35.1/35.4
Metering device		TXV	TXV	TXV	TXV
High–press. Trip / Reset (psig)		630 / 505	630 / 505	630 / 505	630 / 505
Low–press. Trip / Reset (psig)		54 / 117	54 / 117	54 / 117	54 / 117
Compressor Capacity Staging (%)		50% / 100%	50% / 100%	50% / 100%	50% / 100%
Evap. Coil					
Material		Cu / Al	Cu / Al	Cu / Al	Cu / Al
Tube Diameter		3/8–in RTPF	3/8–in RTPF	3/8–in RTPF	3/8–in RTPF
Rows / FPI		4 / 15	4 / 15	4 / 15	4 / 15
Total face area (ft2)		22	22	26	26
Condensate drain conn. size		3/4–in	3/4–in	3/4–in	3/4–in
Hot Gas Reheat (High Static Only)					
Material		Cu / Al	Cu / Al	Cu / Al	Cu / Al
Tube Diameter		3/8–in RTPF	3/8–in RTPF	3/8–in RTPF	3/8–in RTPF
Rows / FPI		1 / 17	1 / 17	1 / 17	1 / 17
Total face area (ft2)		22	22	26	26
Evap. fan and motor					
VERTICAL					
Standard Static	Motor Qty / Drive type	1 / Belt	1 / Belt	1 / Belt	1 / Belt
	Max BHP	2.2	3.3	4.9	4.9
	RPM range	514–680	622–822	690–863	717–911
	Motor frame size	56	56	56	56
	Fan Qty / Type	2 / Centrifugal	2 / Centrifugal	2 / Centrifugal	2 / Centrifugal
	Fan Diameter (in)	15 x 15	15 x 15	15 x 15	15 x 15
Medium Static	Motor Qty / Drive type	1 / Belt	1 / Belt	1 / Belt	1 / Belt
	Max BHP	3.3	4.9	6.5	6.5
	RPM range	679–863	713–879	835–1021	913–1116
	Motor frame size	56	56	184T	184T
	Fan Qty / Type	2 / Centrifugal	2 / Centrifugal	2 / Centrifugal	2 / Centrifugal
	Fan Diameter (in)	15 x 15	15 x 15	15 x 15	15 x 15
High Static	Motor Qty / Drive type	1 / Belt	1 / Belt	1 / Belt	1 / Belt
	Max BHP	4.9	6.5	8.7	8.7
	RPM range	826–1009	882–1078	941–1176	941–1176
	Motor frame size	56	184T	213T	213T
	Fan Qty / Type	2 / Centrifugal	2 / Centrifugal	2 / Centrifugal	2 / Centrifugal
	Fan Diameter (in)	15 x 15	15 x 15	15 x 15	15 x 15

Table 5 – PHYSICAL DATA (COOLING) 15 – 25 TONS (CONT.)

RAH		181 – 183	210 – 213	240 – 243	300 – 303
HORIZONTAL					
Standard Static	Motor Qty / Drive type	1 / Belt	1 / Belt	1 / Belt	1 / Belt
	Max BHP	2.2	3.3	4.9	4.9
	RPM range	514–680	622–822	690–863	647–791
	Motor frame size	56	56	56	184T
	Fan Qty / Type	2 / Centrifugal	2 / Centrifugal	2 / Centrifugal	2 / Centrifugal
Fan Diameter (in)		18 x 15/15 X 11	18 x 15/15 X 11	18 x 15/15 X 11	18 x 15/15 X 11
Medium Static	Motor Qty / Drive type	1 / Belt	1 / Belt	1 / Belt	1 / Belt
	Max BHP	3.3	4.9	6.5	6.5
	RPM range	614–780	713–879	835–1021	755–923
	Motor frame size	56	56	184T	184T
	Fan Qty / Type	2 / Centrifugal	2 / Centrifugal	2 / Centrifugal	2 / Centrifugal
Fan Diameter (in)		18 x 15/15 X 11	18 x 15/15 X 11	18 x 15/15 X 11	18 x 15/15 X 11
High Static	Motor Qty / Drive type	1 / Belt	1 / Belt	1 / Belt	1 / Belt
	Max BHP	4.9	6.5	8.7	8.7
	RPM range	746–912	882–1078	941–1176	827–1010
	Motor frame size	56	184T	213T	213T
	Fan Qty / Type	2 / Centrifugal	2 / Centrifugal	2 / Centrifugal	2 / Centrifugal
Fan Diameter (in)		18 x 15/15 X 11	18 x 15/15 X 11	18 x 15/15 X 11	18 x 15/15 X 11
Cond. Coil (Circuit A)					
Coil type		RTPF	RTPF	RTPF	RTPF
Coil Length (in)		70	72	82	95
Coil Height (in)		44	44	52	52
Rows / FPI (fins per inch)		2 /17	2 /17	2 /17	2 /17
Total face area (ft2)		21.4	22.0	29.6	34.3
Cond. Coil (Circuit B)					
Coil type		RTPF	RTPF	RTPF	RTPF
Coil Length (in)		70	64	80	95
Coil Height (in)		44	44	52	52
Rows / FPI (fins per inch)		2 /17	2 /17	2 /17	2 /17
Total face area (ft2)		21.4	19.5	29.6	34.3
Cond. fan / motor					
Qty / Motor drive type		3 / direct	4 / direct	4/ direct	6 / direct
Motor HP / RPM		1/4 / 1100	1/4 / 1100	1/4 / 1100	1/4 / 1100
Fan diameter (in)		22	22	22	22
Filters					
RA Filter # / size (in)		6 / 20 x 25 x 2	6 / 20 x 25 x 2	9 / 16 x 25 x 2	9 / 16 x 25 x 2
OA inlet screen # / size (in)		4 / 16 x 25 x 1	4 / 16 x 25 x 1	4 / 16 x 25 x 1	4 / 16 x 25 x 1

BASE UNIT DIMENSIONS - RAH181/183

NOTES:

1. DIMENSIONS ARE IN INCHES, DIMENSIONS IN [] ARE IN MILLIMETERS.
2.  CENTER OF GRAVITY
3.  DIRECTION OF AIR FLOW

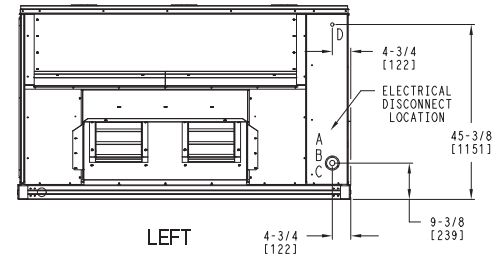
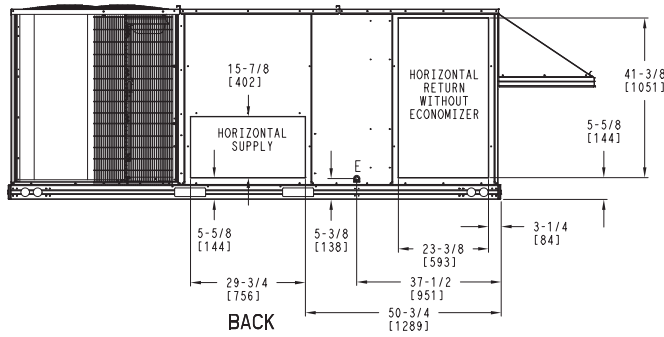
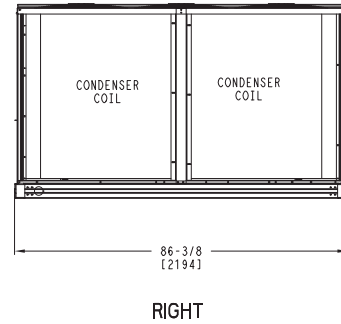
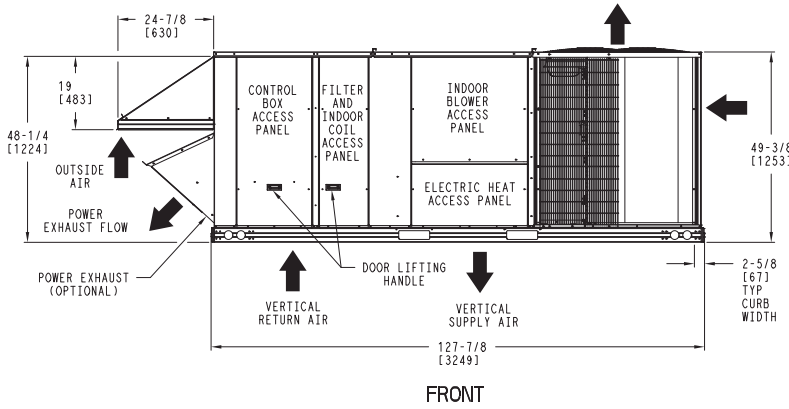
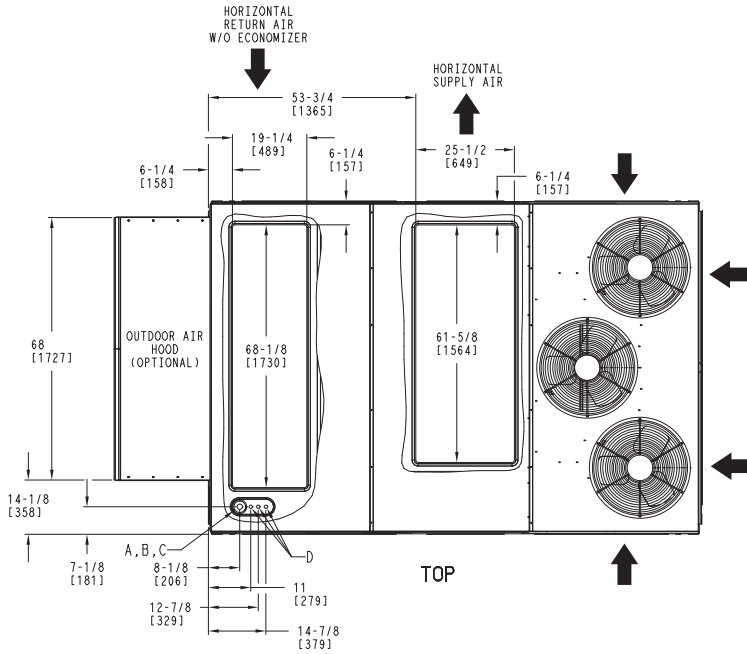

(HORIZONTAL DISCHARGE W/O ECON)
(WHEN ORDERED)

CONNECTION SIZES	
A	1 3/8" DIA [35] FIELD POWER SUPPLY KNOCKOUT
B	3" DIA [76] FIELD POWER SUPPLY KNOCKOUT
C	3 5/8" DIA [92] FIELD POWER SUPPLY KNOCKOUT
D	7/8" DIA [22] FIELD CONTROL WIRING HOLE
E	3/4"-14 NPT CONDENSATE DRAIN

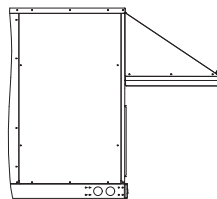

BACK

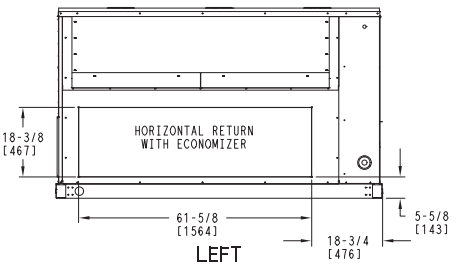

(HORIZONTAL DISCHARGE W/ ECON)
(WHEN ORDERED)

WEIGHT & DIMENSIONS – RAH181/183 (cont.)

UNIT	STD UNIT WEIGHT *		CORNER WEIGHT (A)		CORNER WEIGHT (B)		CORNER WEIGHT (C)		CORNER WEIGHT (D)		C.G.		
	LBS.	KG.	LBS.	KG.	LBS.	KG.	LBS.	KG.	LBS.	KG.	X	Y	Z
15 Ton	1793	815	375	170	419	191	528	240	472	214	48 [1219]	67 3/8 [1711]	16 1/2 [419]

* STANDARD UNIT WEIGHT IS WITHOUT ELECTRIC HEAT AND WITHOUT PACKAGING.

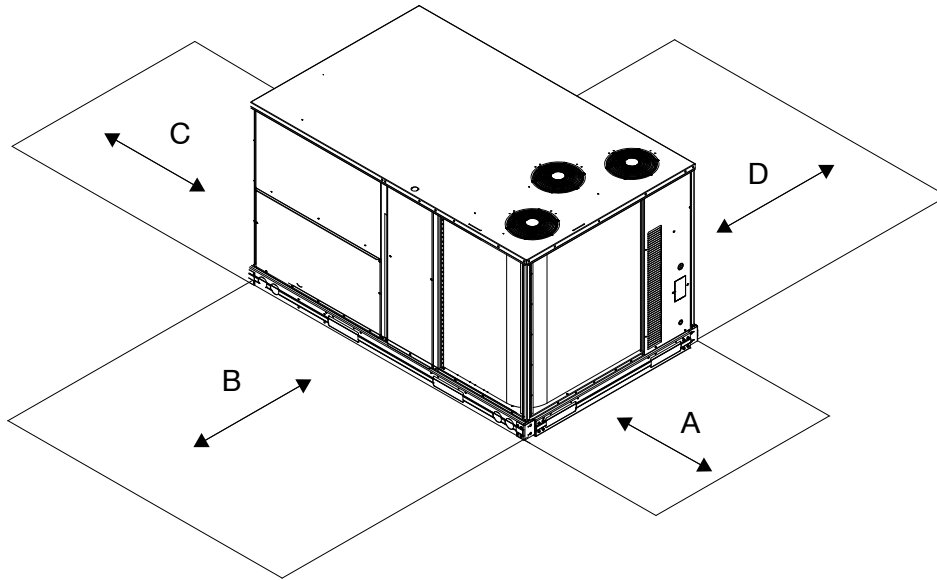
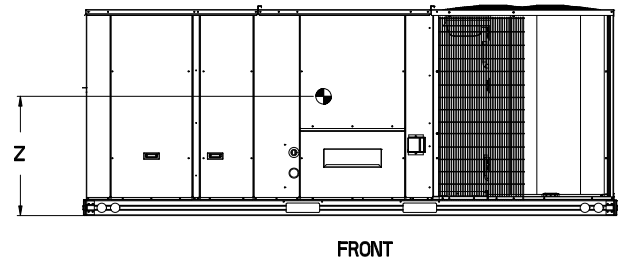
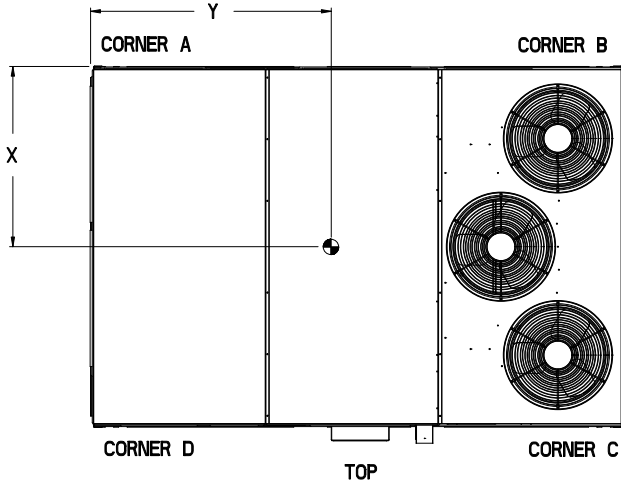

LOC	DIMENSION	CONDITION
A	36-in	Recommended clearance for airflow and service.
B	42-in	Recommended clearance for airflow and service.
C	18-in	1. No CO. 2. No Economizer. 3. No field installed disconnect on economizer hood side (Factory-installed disconnect installed).
	36-in	1. CO installed. 2. Vertical surface behind servicer is electrically non-conductive (e.g., wood, fiberglass).
	42-in	1. CO installed. 2. Vertical surface behind servicer is electrically conductive (e.g., metal, masonry)
	96-in	1. Economizer and/or Power Exhaust installed.
D	42-in	Recommended clearance for service.

NOTE: Unit not designed to have overhead obstruction. Contact Application Engineering for guidance on any application planning overhead obstruction or for vertical clearances.

ROOF CURB DETAILS – RAH181/183

RoofCurb Accessory	A	Unit Size
CRRFCURB045A00	1' 2" [356]	15 Ton
CRRFCURB046A00	2' 0" [610]	

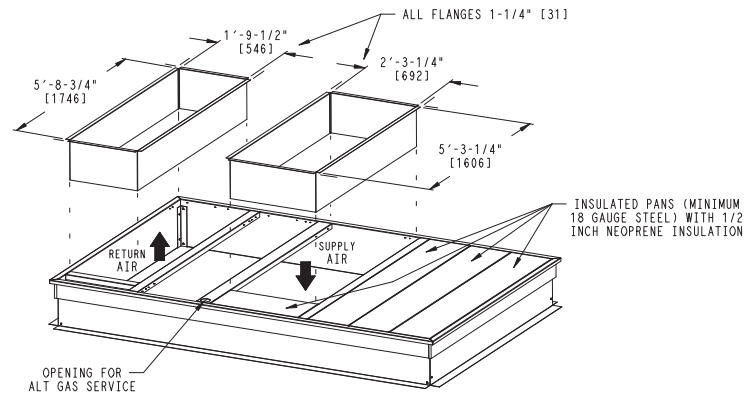
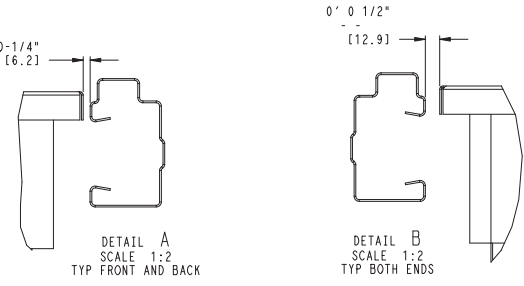
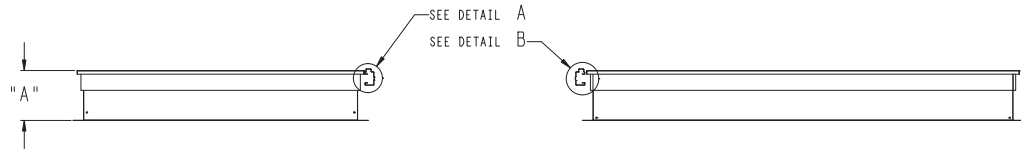
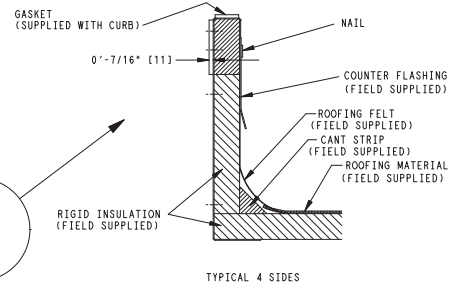
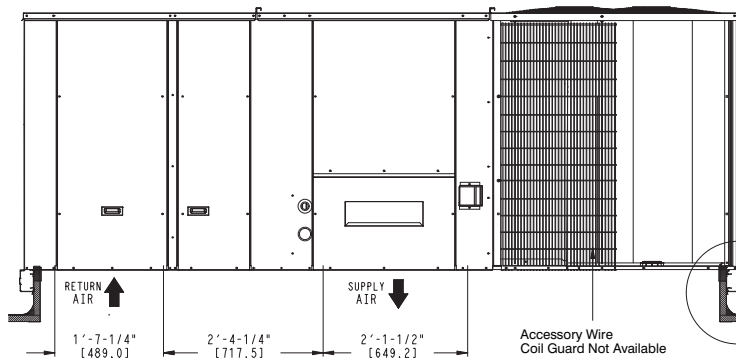
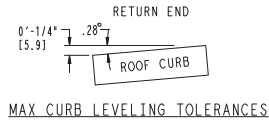
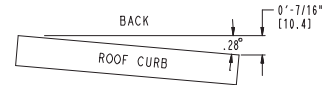
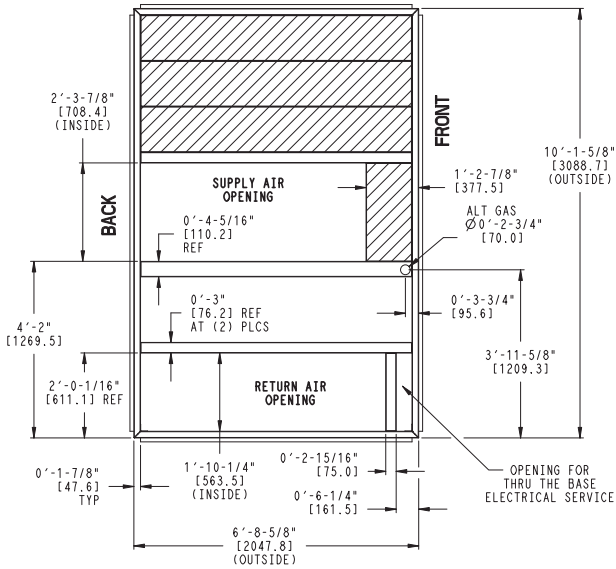

NOTES:

1. Roofcurb accessory is shipped disassembled.
 2. Dimensions in. [] in millimeters.
 3. Roofcurb galvanized steel.
 4. Attach ductwork to curb (Flanges of duct rest on curb)
 5. Service clearance 4' on each side.
- ➡ Direction of airflow.



BASE UNIT DIMENSIONS – RAH210/213 – 240/243

NOTES:

1. DIMENSIONS ARE IN INCHES, DIMENSIONS IN [] ARE IN MILLIMETERS.
2.  CENTER OF GRAVITY
3.  DIRECTION OF AIR FLOW

CONNECTION SIZES	
A	1 3/8" DIA [35] FIELD POWER SUPPLY KNOCKOUT
B	3" DIA [76] FIELD POWER SUPPLY KNOCKOUT
C	3 5/8" DIA [92] FIELD POWER SUPPLY KNOCKOUT
D	7/8" DIA [22] FIELD CONTROL WIRING HOLE
E	3/4"-14 NPT CONDENSATE DRAIN

UNIT	G	H
17.5Ton	41-3/8 [1051]	49-3/8 [1253]
20Ton	49-3/8 [1253]	57-3/8 [1456]

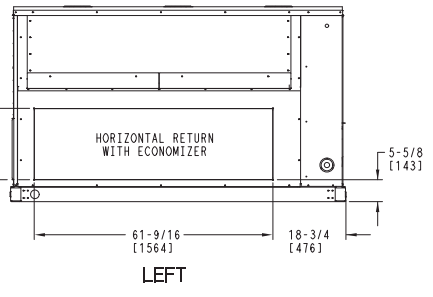
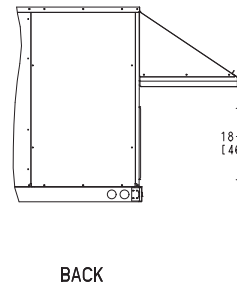
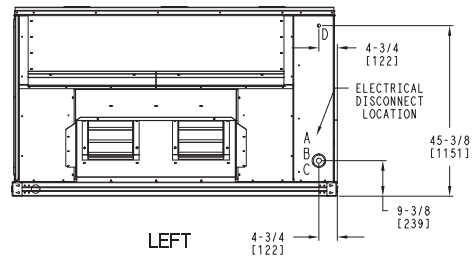
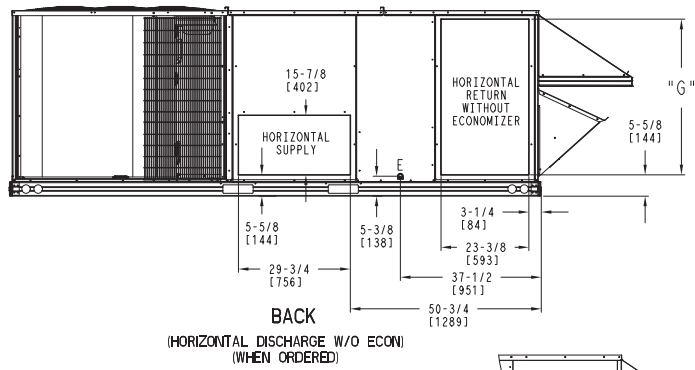
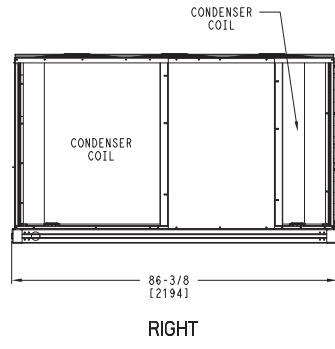
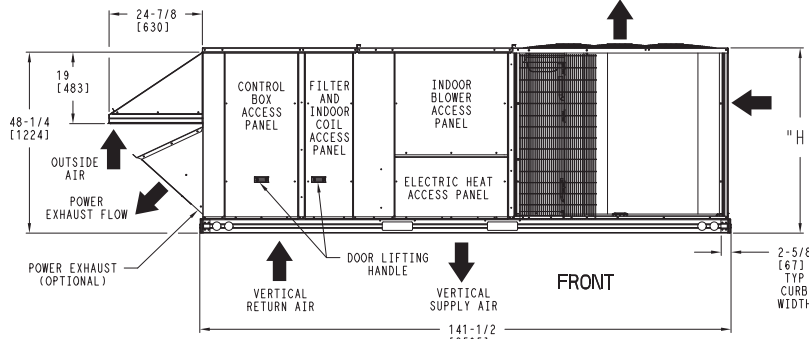
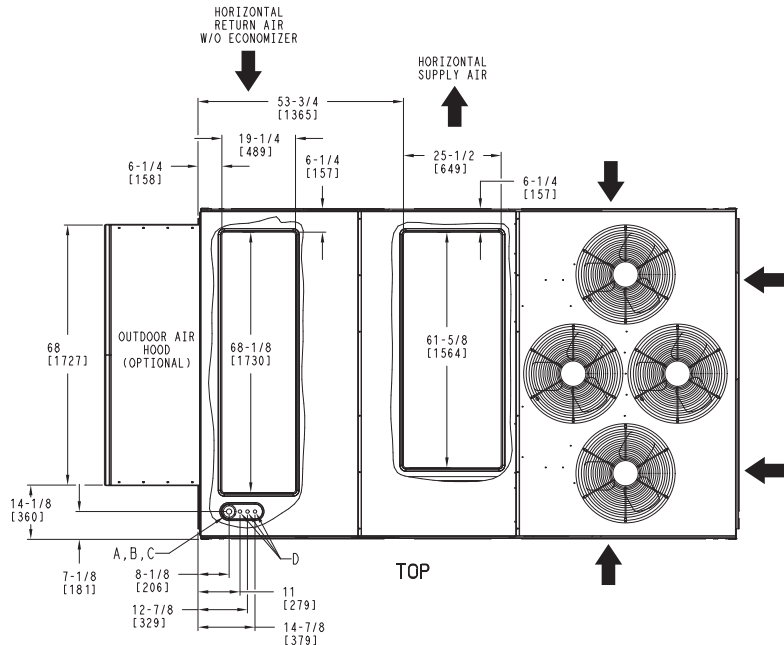

WEIGHT & CLEARANCE DIMENSIONS – RAH210/213 – 240/243 (cont.)

UNIT	STD. UNIT WEIGHT *		CORNER WEIGHT (A)		CORNER WEIGHT (B)		CORNER WEIGHT (C)		CORNER WEIGHT (D)		C.G.		
	LBS.	KG.	LBS.	KG.	LBS.	KG.	LBS.	KG.	LBS.	KG.	X	Y	Z
17.5Ton	2003	911	445	202	367	167	557	253	547	249	47 1/2 [1207]	71 1/4 [1810]	16 1/2 [419]
20Ton	2148	976	510	232	525	238	564	257	549	250	44 5/8 [1133]	71 5/8 [1819]	19 [483]

* STANDARD UNIT WEIGHT IS WITHOUT ELECTRIC HEAT AND WITHOUT PACKAGING.

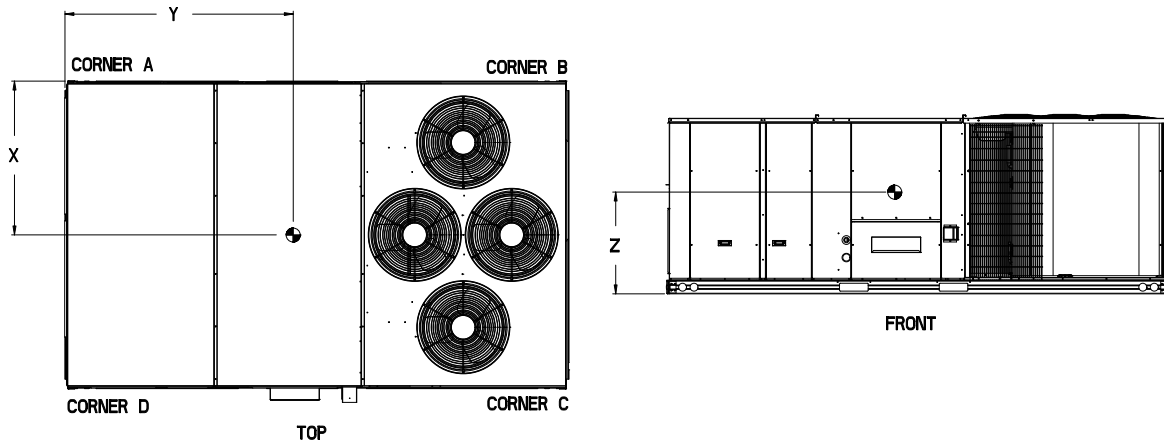

LOC	DIMENSION	CONDITION
A	36-in	Recommended clearance for airflow and service.
B	42-in	Recommended clearance for airflow and service.
C	18-in	1. No CO. 2. No Economizer. 3. No field installed disconnect on economizer hood side (Factory-installed disconnect installed).
	36-in	1. CO installed. 2. Vertical surface behind servicer is electrically non-conductive (e.g., wood, fiberglass).
	42-in	1. CO installed. 2. Vertical surface behind servicer is electrically conductive (e.g., metal, masonry)
	96-in	1. Economizer and/or Power Exhaust installed.
D	42-in	Recommended clearance for service.

NOTE: Unit not designed to have overhead obstruction. Contact Application Engineering for guidance on any application planning overhead obstruction or for vertical clearances.

ROOF CURB DETAILS – RAH210/213 – 240/243

RoofCurb Accessory	A	Unit Size
CRRFCURB047A00	1' 2" [356]	17.5 ton
CRRFCURB048A00	2' 0" [610]	20 ton

NOTES:

1. Roofcurb accessory is shipped disassembled.
 2. Dimensions in. [] in millimeters.
 3. Roofcurb galvanized steel.
 4. Attach ductwork to curb (Flanges of duct rest on curb)
 5. Service clearance 4' on each side.
- ➡ Direction of airflow.

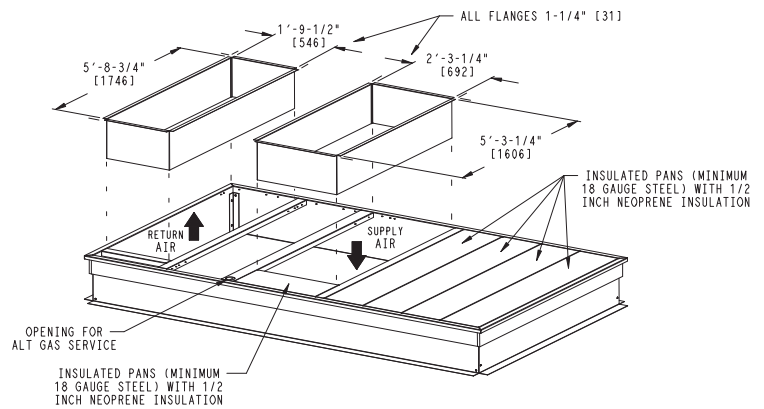
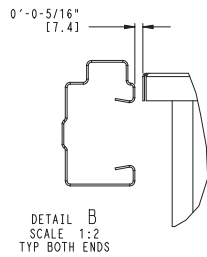
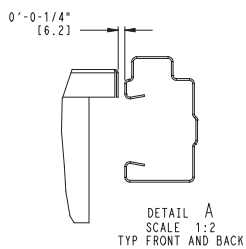
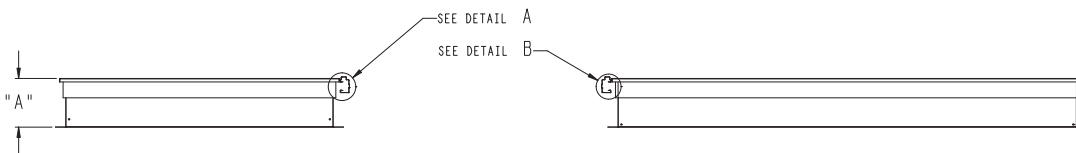
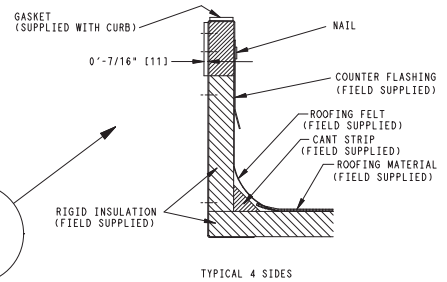
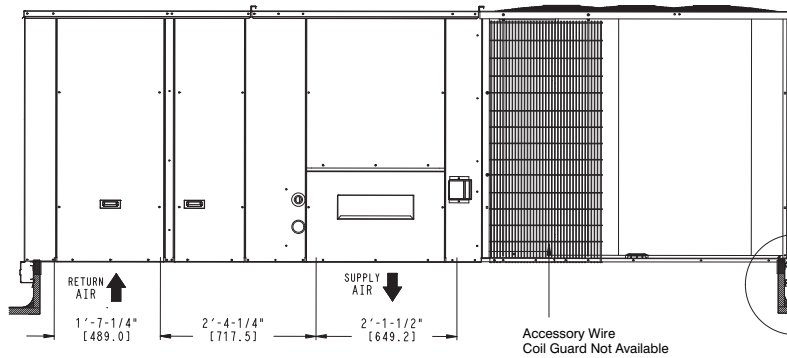
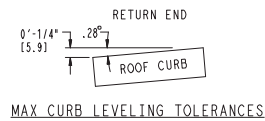
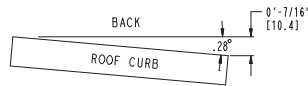
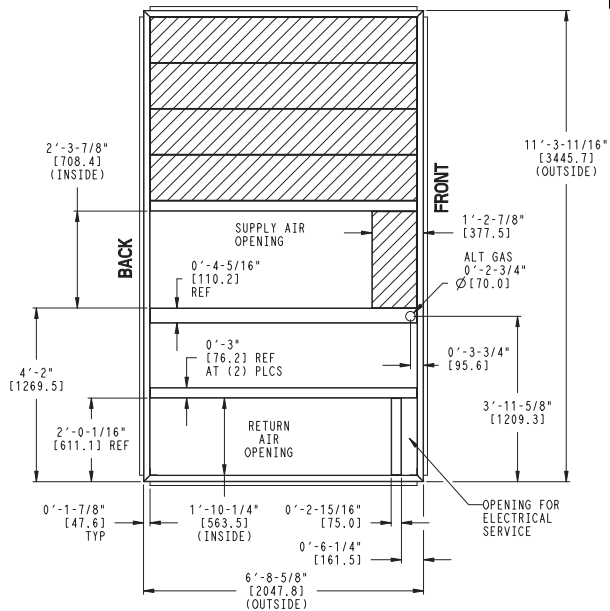

BASE UNIT DIMENSIONS – RAH300/303

NOTES:

1. DIMENSIONS ARE IN INCHES, DIMENSIONS IN [] ARE IN MILLIMETERS.

2.  CENTER OF GRAVITY

3.  DIRECTION OF AIR FLOW

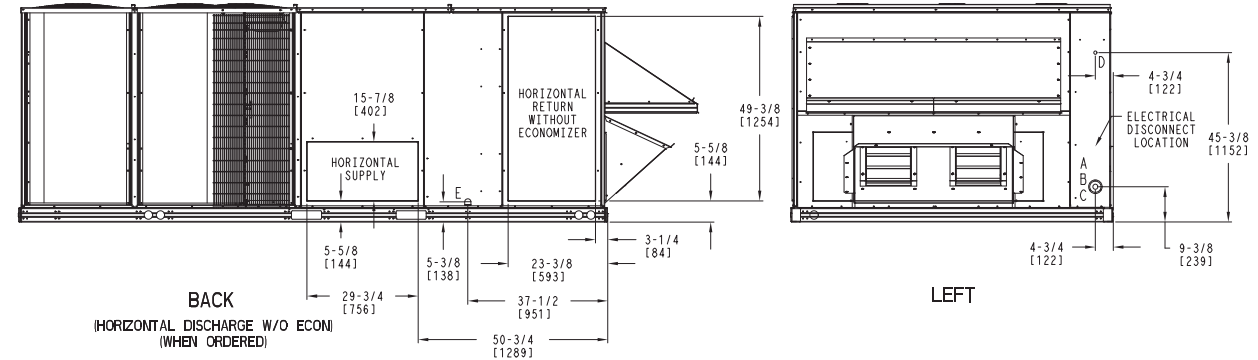
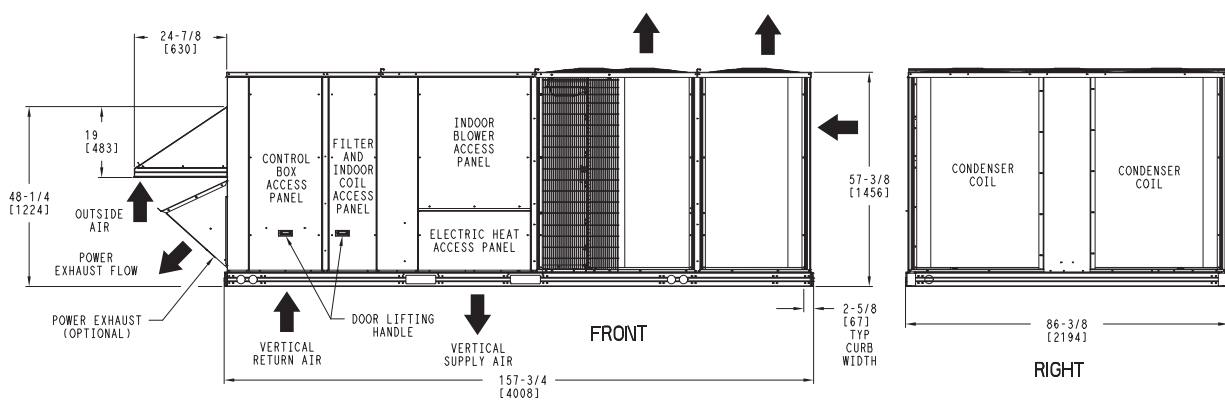
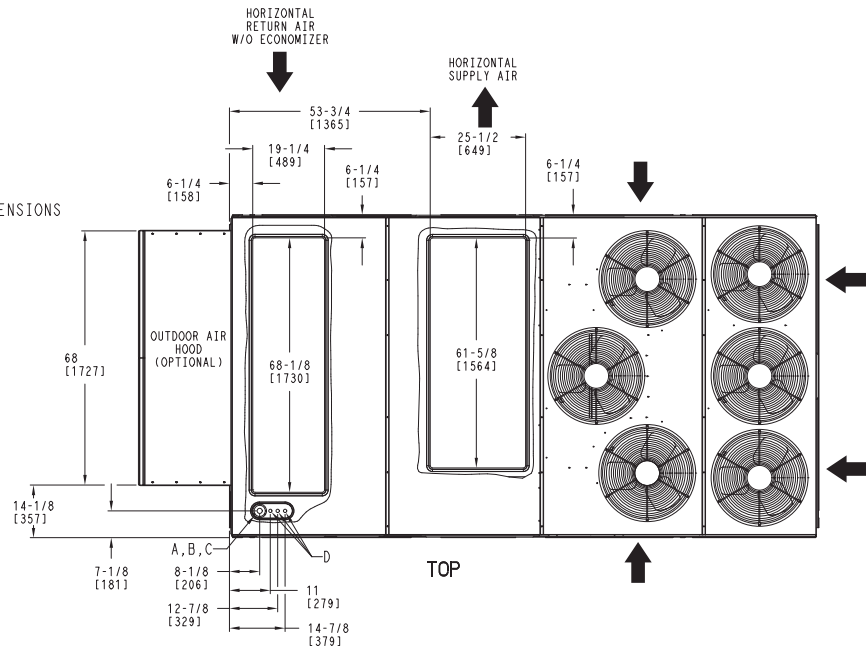

CONNECTION SIZES	
A	1 3/8" DIA [35] FIELD POWER SUPPLY KNOCKOUT
B	3" DIA [76] FIELD POWER SUPPLY KNOCKOUT
C	3 5/8" DIA [92] FIELD POWER SUPPLY KNOCKOUT
D	7/8" DIA [22] FIELD CONTROL WIRING HOLE
E	3/4"-14 NPT CONDENSATE DRAIN

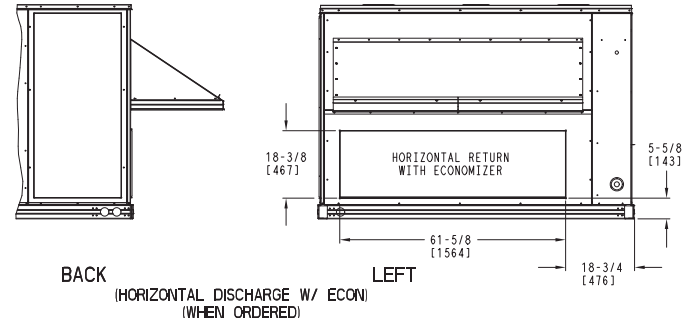

WEIGHT & CLEARANCE DIMENSIONS – RAH300/303 (cont.)

UNIT	STD UNIT WEIGHT *		CORNER WEIGHT (A)		CORNER WEIGHT (B)		CORNER WEIGHT (C)		CORNER WEIGHT (D)		C.G.		
	LBS.	KG.	LBS.	KG.	LBS.	KG.	LBS.	KG.	LBS.	KG.	X	Y	Z
25 Ton	2193	997	545	248	528	240	551	251	569	259	44 [1118]	77 1/2 [1969]	19 [483]

* STANDARD UNIT WEIGHT IS WITHOUT ELECTRIC HEAT AND WITHOUT PACKAGING.

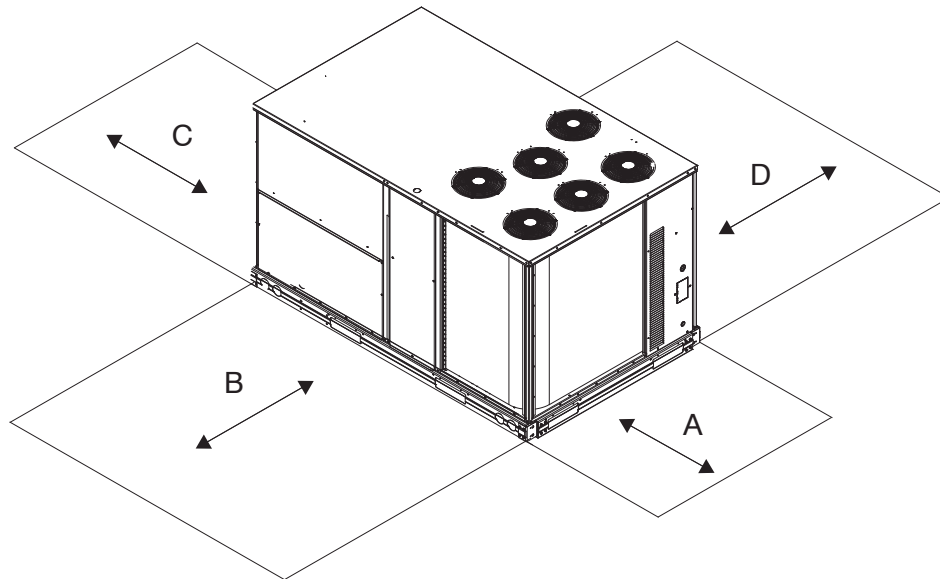
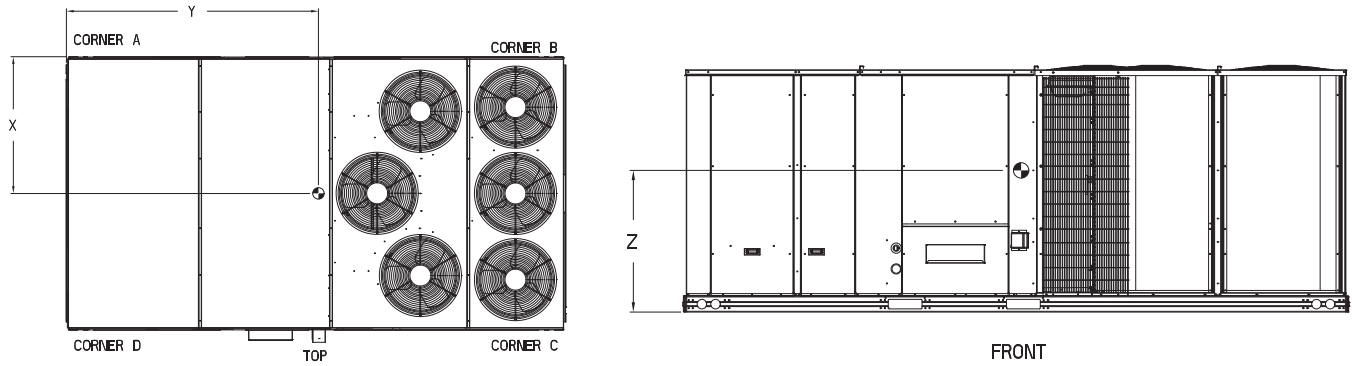

LOC	DIMENSION	CONDITION
A	36-in	Recommended clearance for airflow and service.
B	42-in	Recommended clearance for airflow and service.
C	18-in	1. No CO. 2. No Economizer. 3. No field installed disconnect on economizer hood side (Factory-installed disconnect installed).
	36-in	1. CO installed. 2. Vertical surface behind servicer is electrically non-conductive (e.g., wood, fiberglass).
	42-in	1. CO installed. 2. Vertical surface behind servicer is electrically conductive (e.g., metal, masonry)
	96-in	1. Economizer and/or Power Exhaust installed.
D	42-in	Recommended clearance for service.

NOTE: Unit not designed to have overhead obstruction. Contact Application Engineering for guidance on any application planning overhead obstruction or for vertical clearances.

ROOF CURB DETAILS – RAH300/303

RoofCurb Accessory	A	Unit Size
CRRFCURB049A00	1' 2" [356]	25 ton
CRRFCURB050A00	2' 0" [610]	

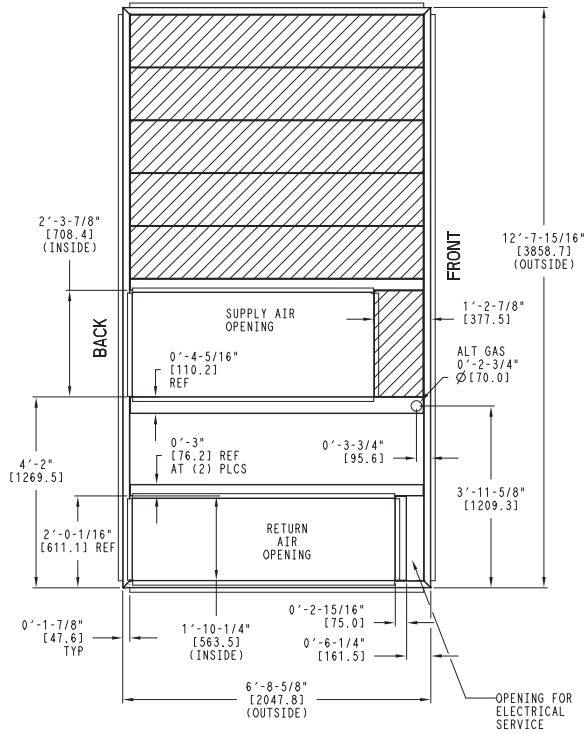

- NOTES:
- 1 ROOF CURB ACCESSORY IS SHIPPED UNASSEMBLED.
 - 2 BOLT HEADS TO BE ON INSIDE OF FLANGE. CLEARANCE IS [11] 0-0-7/16" TYP ALL CORNERS.
 - 3 DIMENSIONS IN [] ARE IN MILLIMETERS.
 - 4 ROOF CURB GALVANIZED STEEL.
 - 5 ATTACH DUCTWORK TO CURB (FLANGES ON DUCT REST ON CURB)
 - 6 SERVICE CLEARANCE 4 ft ON EACH SIDE
 - 7 GAS SERVICE PLATE IS PART OF A SEPARATELY SHIPPED ACCESSORY PACKAGE.
 - 8 GAS SERVICE PLATE CAN BE USED WITH EITHER ACCESSORY ROOFCURB.

➔ DIRECTION OF AIR FLOW

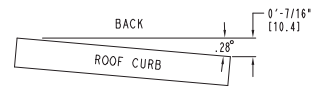

MAX CURB LEVELING TOLERANCES

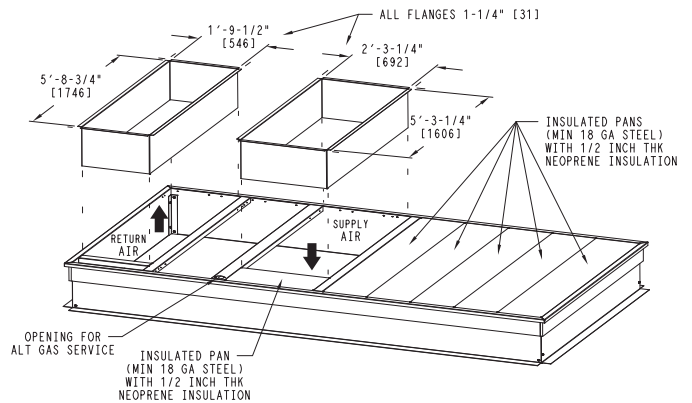
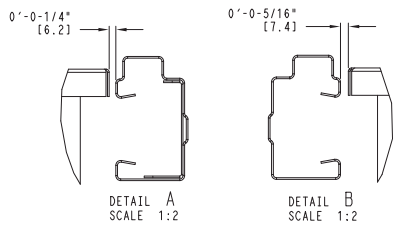
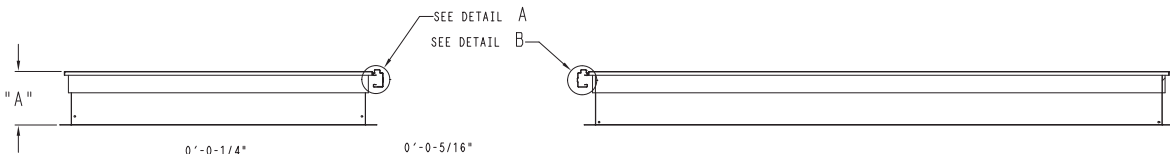
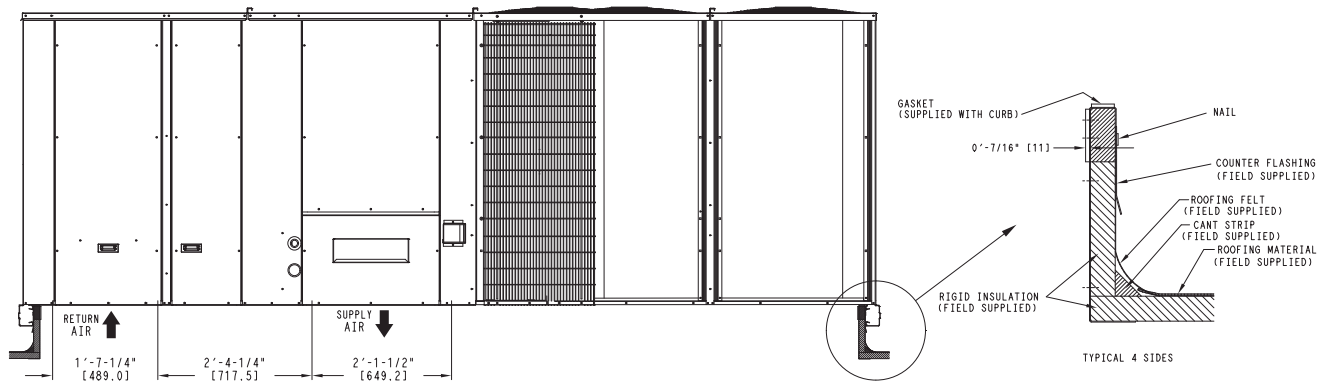

TABLE 6 – OPTIONS AND ACCESSORIES WEIGHT ADDERS

BASE UNIT WITH OPTIONS AND ACCESSORIES (Weight Adders)	MAX WEIGHT ADD							
	RAH181/183		RAH210/213		RAH240/243		RAH300/303	
	lb	kg	lb	kg	lb	kg	lb	kg
HOT GAS REHEAT	83	38	83	38	88	40	92	42
Base Unit Operating Weight	1793	813	2003	909	2148	974	2193	975
Power Exhaust	125	57	125	57	125	57	125	57
Economizer	170	77	170	77	170	77	195	88
Copper Tube/Fin Evaporator Coil	110	50	110	50	135	61	161	73
Electric Heater	85	39	85	39	85	39	85	39
Single Point Kit	15	7	15	7	15	7	15	7
Roof Curb 14–in (356mm)	240	109	240	109	240	109	255	116
Roof Curb 24–in (610mm)	340	154	340	154	340	154	355	161
Louvered Hail Guard	60	27	60	27	120	54	150	68
CO ₂ sensor	5	2	5	2	5	2	5	2
Supply Smoke Detector	5	2	5	2	5	2	5	2
Fan/Filter Status Switch	2	1	2	1	2	1	2	1
Non–Fused Disconnect	15	7	15	7	15	7	15	7
Non–Powered Convenience Outlet	5	2	5	2	5	2	5	2
Enthalpy Sensor	2	1	2	1	2	1	2	1
Differential Enthalpy Sensor	3	1	3	1	3	1	3	1
Two Position Motorized Damper	50	23	50	23	50	23	65	29
Manual Damper	35	16	35	16	35	16	40	18
Field Filter Track 4–in (102mm)	12	5	12	5	12	5	12	5
MotorMaster Controller	35	16	35	16	35	16	35	16
Standard Static Motor/Drive	0	0	0	0	0	0	0	0
Medium Static Motor/Drive	5	2	6	3	6	3	6	3
High Static Motor/Drive	11	5	12	5	16	7	16	7
Barometric Relief Hood (Horizontal)	25	11	25	11	25	11	25	11
2–speed indoor fan motor system with VFD	20	9	20	9	20	9	20	9

APPLICATION DATA

Min operating ambient temp (cooling):

In mechanical cooling mode, your rooftop can safely operate down to an outdoor ambient temperature of 35°F (2°C). It is possible to provide cooling at lower outdoor ambient temperatures by using less outside air, economizers, and/or accessory low ambient kits.

Max operating ambient temp (cooling):

The maximum operating ambient temperature for cooling mode is 125°F (52°C). While cooling operation above 125°F (52°C) may be possible, it could cause either a reduction in performance, reliability, or a protective action by the unit's internal safety devices.

Min and max airflow (cooling mode):

To maintain safe and reliable operation of your rooftop, operate within the cooling airflow limits. Operating above the max may cause blow-off, undesired airflow noise, or airflow related problems with the rooftop unit. Operating below the min may cause problems with coil freeze-up.

Airflow:

All units are draw-through in cooling mode.

Outdoor air application strategies:

Economizers reduce operating expenses and compressor run time by providing a free source of cooling and a means of ventilation to match application changing needs. In fact, they should be considered for most applications. Also, consider the various economizer control methods and their benefits, as well as sensors required to accomplish your application goals. Please contact your local representative for assistance.

Motor limits, break horsepower (BHP):

Due to the internal unit design, air path, and specially designed motors, the full horsepower (maximum continuous BHP) band, as listed in Table 5, can be used with the utmost confidence. There is no need for extra safety factors, our motors are designed and rigorously tested to use the entire, listed BHP range without either nuisance tripping or premature motor failure.

Sizing a rooftop

Bigger isn't necessarily better. While an air conditioner needs to have enough capacity to meet the load, it doesn't need excess capacity. In fact, having excess capacity typically results in very poor part load performance and humidity control.

Using higher design temperatures than ASHRAE recommends for your location, adding "safety factors" to the calculated load, and rounding up to the next largest unit, are all signs of oversizing air conditioners. Oversizing can cause short-cycling, and short cycling leads to poor humidity control, reduced efficiency, higher utility bills, drastic indoor temperature swings, excessive noise, and increased wear and tear on the air conditioner.

Rather than oversizing an air conditioner, wise contractors and engineers "right-size" or even slightly undersize air conditioners. Correctly sizing an air conditioner controls humidity better; promotes efficiency; reduces utility bills; extends equipment life, and maintains even, comfortable temperatures.

Low ambient applications

When equipped with an economizer, your rooftop unit can cool your space by bringing in fresh, cool outside air. In fact, when so equipped, accessory low-ambient kit may not be necessary. In low ambient conditions, unless the outdoor air is excessively humid or contaminated, economizer-based "free cooling" is the preferred less costly and energy conscious method.

In low ambient applications where outside air might not be desired (such as contaminated or excessively humid outdoor environments), your rooftop can operate to ambient temperatures down to -20°F (-29°C) using the recommended accessory Motormaster low ambient controller.

Winter start

A winter start kit extends the low ambient limit of your rooftop to 25°F (-4°C). The kit bypasses the low pressure switch, preventing nuisance tripping of the low pressure switch. Other low ambient precautions may still be prudent.

2-Speed Indoor Fan Motor System with Variable Frequency Drive (VFD)

The 2-speed indoor fan motor system utilizes a Variable Frequency Drive (VFD) to automatically adjust the indoor fan motor speed in sequence with the units cooling operation. Per ASHRAE 90.1 2010 standard section 6.4.3.10.b, during the first stage of cooling operation the VFD will adjust the fan motor to provide 2/3rd of the total cfm established for the unit. When a call for the second stage of cooling is required, the VFD will allow the total cfm for the unit established (100%). During the heating mode, the VFD will allow total design cfm (100%) operation and during the ventilation mode the VFD will allow operation to 2/3rd of total cfm.

The VFD used in the 2-speed indoor fan motor system has soft start capabilities to slowly ramp up the speeds, thus eliminating any high inrush air volume during initial start-up. It also has internal over current protection for the fan motor and a field installed display kit that allows adjustment and in depth diagnostics of the VFD.

This 2-speed indoor fan motor system is available on models with 2-stage cooling operation with electrical mechanical or RTU Open (multi Protocol) controls. Both space sensor and conventional thermostats controls can be used to provide accurate control in any application.

The 2-speed indoor fan motor system is very flexible for initial fan performance set up and adjustment. The standard factory shipped VFD is pre programmed to automatically stage the fan speed between the first and second stage of cooling. The unit fan performance static pressure and cfm can be easily adjusted using the traditional means of pulley adjustments. The other means to adjust the unit static and cfm performance is to utilize the field installed display module and adjust the frequency and voltage in the VFD to required performance requirements. In either case, once set up the VFD will automatically adjust the speed between the cooling stage operation.

TABLE 7 – COOLING CAPACITIES 15 TONS (2 Stage Cooling)

RAH181/183				AMBIENT TEMPERATURE															
				85			95			105			115			125			
				EA (dB)			EA (dB)			EA (dB)			EA (dB)			EA (dB)			
				75	80	85	75	80	85	75	80	85	75	80	85	75	80	85	
4500 CFM	EAT (wb)	58	TC	158.3	158.3	179.2	152.6	152.6	172.9	146.6	146.6	166.1	140.2	140.2	158.8	133.2	133.2	150.8	
			SHC	137.3	158.3	179.2	132.4	152.6	172.9	127.2	146.6	166.1	121.6	140.2	158.8	115.5	133.2	150.8	
		62	TC	166.8	166.8	169.0	159.5	159.5	165.6	151.8	151.8	161.9	143.6	143.6	157.9	134.9	134.9	153.4	
			SHC	123.1	146.1	169.0	119.7	142.6	165.6	116.1	139.0	161.9	112.3	135.1	157.9	108.2	130.8	153.4	
		67	TC	182.9	182.9	182.9	174.9	174.9	174.9	166.3	166.3	166.3	157.2	157.2	157.2	147.6	147.6	147.6	
			SHC	100.0	123.1	146.1	96.7	119.8	142.8	93.2	116.3	139.4	89.7	112.7	135.7	85.9	108.9	131.9	
	72	TC	200.5	200.5	200.5	191.6	191.6	191.6	182.2	182.2	182.2	172.2	172.2	172.2	161.7	161.7	161.7		
		SHC	76.1	99.5	122.8	72.9	96.2	119.5	69.5	92.8	116.1	66.0	89.3	112.5	62.4	85.6	108.8		
	76	TC	–	215.4	215.4	–	205.8	205.8	–	195.6	195.6	–	184.8	184.8	–	173.6	173.6		
		SHC	–	80.2	105.0	–	77.1	101.7	–	73.7	98.2	–	70.2	94.5	–	66.7	90.7		
	5250 CFM	EAT (wb)	58	TC	166.7	166.7	188.8	160.6	160.6	181.9	154.0	154.0	174.4	147.0	147.0	166.5	139.5	139.5	157.9
				SHC	144.6	166.7	188.8	139.3	160.6	181.9	133.6	154.0	174.4	127.6	147.0	166.5	121.0	139.5	157.9
62			TC	172.0	172.0	185.1	164.3	164.3	181.2	156.3	156.3	177.0	147.8	147.8	172.4	139.6	139.6	164.3	
			SHC	132.5	158.8	185.1	128.9	155.1	181.2	125.0	151.0	177.0	120.9	146.6	172.4	114.9	139.6	164.3	
67			TC	188.3	188.3	188.3	179.7	179.7	179.7	170.7	170.7	170.7	161.0	161.0	161.0	150.9	150.9	150.9	
			SHC	106.1	132.7	159.3	102.8	129.3	155.9	99.3	125.8	152.4	95.6	122.1	148.6	91.7	118.2	144.7	
72		TC	206.1	206.1	206.1	196.7	196.7	196.7	186.7	186.7	186.7	176.2	176.2	176.2	165.3	165.3	165.3		
		SHC	78.8	105.6	132.5	75.5	102.3	129.1	72.1	98.8	125.6	68.5	95.2	121.9	64.8	91.4	118.0		
76		TC	–	221.2	221.2	–	211.0	211.0	–	200.3	200.3	–	189.0	189.0	–	177.2	177.2		
		SHC	–	83.6	111.7	–	80.3	108.2	–	76.9	104.6	–	73.3	100.9	–	69.7	97.1		
6000 CFM		EAT (wb)	58	TC	173.8	173.8	196.8	167.2	167.2	189.4	160.2	160.2	181.4	152.7	152.7	173.0	144.7	144.7	163.8
				SHC	150.8	173.8	196.8	145.1	167.2	189.4	139.0	160.2	181.4	132.5	152.7	173.0	125.5	144.7	163.8
	62		TC	176.3	176.3	199.5	168.5	168.5	194.9	160.5	160.5	188.9	152.9	152.9	179.9	144.8	144.8	170.4	
			SHC	140.9	170.2	199.5	136.9	165.9	194.9	132.1	160.5	188.9	125.8	152.9	179.9	119.2	144.8	170.4	
	67		TC	192.3	192.3	192.3	183.4	183.4	183.4	173.9	173.9	173.9	164.0	164.0	164.0	153.4	153.4	156.9	
			SHC	112.0	142.0	172.0	108.5	138.5	168.5	104.9	134.9	164.8	101.2	131.1	161.0	97.2	127.1	156.9	
	72	TC	210.4	210.4	210.4	200.6	200.6	200.6	190.2	190.2	190.2	179.3	179.3	179.3	167.9	167.9	167.9		
		SHC	81.2	111.4	141.7	77.9	108.0	138.2	74.4	104.5	134.6	70.7	100.8	130.8	67.0	96.9	126.9		
	76	TC	–	225.6	225.6	–	215.0	215.0	–	203.8	203.8	–	192.1	192.1	–	180.0	180.0		
		SHC	–	86.7	117.9	–	83.3	114.5	–	79.9	110.8	–	76.3	107.1	–	72.6	103.2		
	6750 CFM	EAT (wb)	58	TC	179.8	179.8	203.7	172.9	172.9	195.8	165.5	165.5	187.4	157.5	157.5	178.4	149.0	149.0	168.8
				SHC	156.0	179.8	203.7	150.0	172.9	195.8	143.5	165.5	187.4	136.7	157.5	178.4	129.3	149.0	168.8
62			TC	180.5	180.5	210.7	173.0	173.0	203.6	165.6	165.6	194.9	157.7	157.7	185.5	149.1	149.1	175.5	
			SHC	147.6	179.2	210.7	142.4	173.0	203.6	136.3	165.6	194.9	129.8	157.7	185.5	122.8	149.1	175.5	
67			TC	195.6	195.6	195.6	186.2	186.2	186.2	176.5	176.5	176.8	166.2	166.2	172.7	155.4	155.4	168.4	
			SHC	117.5	150.8	184.1	114.0	147.3	180.5	110.4	143.6	176.8	106.5	139.6	172.7	102.4	135.4	168.4	
72		TC	213.8	213.8	213.8	203.6	203.6	203.6	192.9	192.9	192.9	181.6	181.6	181.6	169.9	169.9	169.9		
		SHC	83.5	117.0	150.5	80.1	113.5	147.0	76.5	109.9	143.3	72.8	106.1	139.4	69.1	102.3	135.5		
76		TC	–	229.1	229.1	–	218.1	218.1	–	206.6	206.6	–	194.6	194.6	–	182.1	182.1		
		SHC	–	89.6	124.0	–	86.2	120.5	–	82.7	116.8	–	79.0	113.0	–	75.2	109.0		
7500 CFM		EAT (wb)	58	TC	185.1	185.1	209.6	177.7	177.7	201.3	170.0	170.0	192.5	161.6	161.6	183.0	152.8	152.8	173.0
				SHC	160.6	185.1	209.6	154.2	177.7	201.3	147.5	170.0	192.5	140.2	161.6	183.0	132.5	152.8	173.0
	62		TC	185.2	185.2	218.0	177.9	177.9	209.3	170.1	170.1	200.2	161.8	161.8	190.4	152.9	152.9	179.9	
			SHC	152.5	185.2	218.0	146.4	177.9	209.3	140.0	170.1	200.2	133.2	161.8	190.4	125.8	152.9	179.9	
	67		TC	198.1	198.1	198.1	188.6	188.6	192.1	178.6	178.6	188.1	168.1	168.1	183.8	157.2	157.2	179.1	
			SHC	122.8	159.3	195.9	119.2	155.7	192.1	115.5	151.8	188.1	111.5	147.7	183.8	107.3	143.2	179.1	
	72	TC	216.6	216.6	216.6	206.1	206.1	206.1	195.1	195.1	195.1	183.5	183.5	183.5	171.6	171.6	171.6		
		SHC	85.6	122.3	159.0	82.2	118.8	155.5	78.6	115.2	151.7	74.9	111.3	147.8	71.1	107.4	143.8		
	76	TC	–	231.9	231.9	–	220.7	220.7	–	208.9	208.9	–	196.5	196.5	–	183.8	183.8		
		SHC	–	92.4	129.9	–	88.9	126.3	–	85.4	122.6	–	81.6	118.7	–	77.8	114.6		

LEGEND:

- Do not operate
- Cfm – Cubic feet per minute (supply air)
- EAT(db) – Entering air temperature (dry bulb)
- EAT(wb) – Entering air temperature (wet bulb)
- SHC – Sensible heat capacity
- TC – Total capacity

Table 7 – COOLING CAPACITIES WITH HOT GAS REHEAT 15 TONS (2 Stage Cooling)

RAH180/183 (15 TONS) – UNIT WITH HOT GAS REHEAT IN SUBCOOLING MODE										
Temp (F) Air Ent Condenser (Edb)		AIR ENTERING EVAPORATOR – CFM								
		4,500			6,000			7,500		
		Air Entering Evaporator --- Ewb (F)								
		72	67	62	72	67	62	72	67	62
75	TC	202.9	184.6	166.2	213.7	194.6	175.4	222.3	202.5	182.7
	SHC	91.9	112.4	132.9	106.1	126.4	146.8	117.5	137.7	158.0
	kW	10.19	10.12	9.78	10.51	10.19	9.95	10.61	10.36	10.12
85	TC	189.8	171.8	153.8	201.0	182.2	163.3	209.9	190.4	170.8
	SHC	75.9	101.0	126.2	91.2	116.3	141.3	103.4	128.4	153.5
	kW	11.57	11.49	11.15	11.88	11.56	11.32	11.98	11.73	11.49
95	TC	176.7	159.1	141.4	188.3	169.7	151.2	197.5	178.2	159.0
	SHC	59.8	89.7	119.6	76.2	106.1	135.9	89.4	119.2	149.0
	kW	12.87	12.81	12.47	13.20	12.88	12.64	13.30	13.05	12.81
105	TC	163.6	146.3	129.0	175.6	157.3	139.1	185.1	166.1	147.1
	SHC	43.8	78.4	112.9	61.3	95.9	130.4	75.3	109.9	144.4
	kW	14.05	14.00	13.65	14.39	14.07	13.82	14.40	14.24	14.00
115	TC	150.5	133.5	116.5	162.9	144.9	127.0	172.7	154.0	135.3
	SHC	27.7	67.0	106.3	46.4	85.7	125.0	61.3	100.6	133.4
	kW	15.44	15.36	15.02	15.75	15.43	15.19	15.85	15.60	15.36
125	TC	137.4	120.8	104.1	150.2	132.5	114.9	160.3	141.9	123.5
	SHC	11.7	55.7	99.6	31.4	75.5	112.9	47.3	91.3	123.0
	kW	16.77	16.71	16.37	17.10	16.78	16.54	17.20	16.95	16.71

RAH180/183 (15 TONS) – UNIT WITH HOT GAS REHEAT IN HOT GAS REHEAT MODE										
Temp (F) Air Ent Condenser (Edb)		AIR ENTERING EVAPORATOR – Ewb (F)								
		75 Dry Bulb			75 Dry Bulb			75 Dry Bulb		
		62.5 Wet Bulb			64 Wet Bulb			65.3 Wet Bulb		
		(50% Relative)			(56% Relative)			(60% Relative)		
		Air Entering Evaporator – Cfm								
4,500	6,000	7,500	4,500	6,000	7,500	4,500	6,000	7,500		
80	TC	64.50	71.00	73.30	68.40	74.50	77.30	71.20	79.70	80.60
	SHC	12.60	24.90	36.80	6.80	13.70	23.90	-0.80	5.50	13.80
	kW	10.10	10.26	10.42	10.18	10.40	10.56	10.33	10.47	10.67
75	TC	66.60	73.10	75.60	70.50	76.60	79.50	73.20	80.80	82.90
	SHC	14.30	26.70	38.50	8.10	14.90	25.70	0.70	7.00	15.00
	kW	10.05	10.22	10.36	10.14	10.36	10.52	10.28	10.43	10.62
70	TC	68.70	75.10	77.40	72.50	78.60	81.40	75.20	82.80	84.90
	SHC	15.40	27.80	40.00	9.50	16.20	26.80	2.10	8.40	16.30
	kW	10.00	10.18	10.33	10.10	10.31	10.47	10.23	10.40	10.58
60	TC	72.80	79.30	81.60	76.70	82.80	85.70	79.40	86.90	88.80
	SHC	19.00	31.10	43.20	12.70	19.90	30.10	5.30	11.60	20.00
	kW	9.92	10.09	10.24	10.01	10.22	10.37	10.14	10.31	10.49
50	TC	76.80	83.40	85.70	80.80	86.90	89.70	83.50	90.90	92.80
	SHC	21.70	34.20	46.20	15.80	22.70	33.20	8.40	14.70	22.80
	kW	9.83	10.00	10.15	9.92	10.13	10.29	10.05	10.21	10.39
40	TC	80.90	87.30	89.60	84.90	90.80	93.60	87.40	94.80	96.70
	SHC	24.90	37.10	49.30	19.00	26.00	36.10	11.60	17.90	26.20
	kW	9.74	9.91	10.06	9.83	10.04	10.20	9.96	10.12	10.30

LEGEND

- Edb** – Entering Dry–Bulb
- Ewb** – Entering Wet–Bulb
- kW** – Compressor Motor Power Input
- ldb** – Leaving Dry–Bulb
- lwb** – Leaving Wet–Bulb
- SHC** – Sensible Heat Capacity (1000 Btuh) Gross
- TC** – Total Capacity (1000 Btuh) Gross

NOTES:

1. Direct interpolation is permissible. Do not extrapolate.
1. The following formulas may be used:

$$t_{ldb} = t_{edb} - \frac{\text{sensible capacity (Btuh)}}{1.10 \times \text{cfm}}$$

$$t_{lwb} = \text{Wet–bulb temperature corresponding to enthalpy of air leaving evaporator coil (} h_{lwb} \text{)}$$

$$h_{lwb} = h_{ewb} - \frac{\text{total capacity (Btuh)}}{4.5 \times \text{cfm}}$$

Where: h_{ewb} = Enthalpy of air entering evaporator coil

TABLE 8 – COOLING CAPACITIES 17.5 TONS (2 Stage Cooling)

RAH210/213				AMBIENT TEMPERATURE														
				85			95			105			115			125		
				EA (dB)			EA (dB)			EA (dB)			EA (dB)			EA (dB)		
				75	80	85	75	80	85	75	80	85	75	80	85	75	80	85
5250 CFM	EAT (wb)	58	TC	185.1	185.1	209.2	178.7	178.7	201.9	171.8	171.8	194.1	164.5	164.5	185.8	156.7	156.7	177.0
			SHC	161.1	185.1	209.2	155.4	178.7	201.9	149.4	171.8	194.1	143.1	164.5	185.8	136.3	156.7	177.0
		62	TC	193.8	193.8	199.5	185.6	185.6	195.4	176.9	176.9	191.1	167.7	167.7	186.4	158.2	158.2	181.1
			SHC	145.6	172.6	199.5	141.7	168.6	195.4	137.6	164.4	191.1	133.2	159.8	186.4	128.3	154.7	181.1
		67	TC	212.2	212.2	212.2	203.3	203.3	203.3	193.8	193.8	193.8	183.8	183.8	183.8	173.1	173.1	173.1
			SHC	119.0	146.0	173.1	115.3	142.3	169.4	111.4	138.4	165.4	107.3	134.3	161.3	103.0	130.0	157.0
		72	TC	232.3	232.3	232.3	222.7	222.7	222.7	212.4	212.4	212.4	201.6	201.6	201.6	190.1	190.1	190.1
			SHC	91.5	118.8	146.2	87.9	115.2	142.5	84.1	111.4	138.7	80.2	107.4	134.6	76.0	103.2	130.4
		76	TC	–	249.5	249.5	–	239.2	239.2	–	228.2	228.2	–	216.6	216.6	–	204.3	204.3
			SHC	–	96.7	125.3	–	93.2	121.7	–	89.5	117.9	–	85.6	113.8	–	81.5	109.5
6125 CFM	EAT (wb)	58	TC	194.7	194.7	220.0	187.8	187.8	212.2	180.4	180.4	203.8	172.5	172.5	194.9	164.1	164.1	185.5
			SHC	169.4	194.7	220.0	163.3	187.8	212.2	156.9	180.4	203.8	150.1	172.5	194.9	142.8	164.1	185.5
		62	TC	199.6	199.6	218.0	191.1	191.1	213.5	182.1	182.1	208.4	173.0	173.0	201.2	164.3	164.3	192.8
			SHC	156.5	187.2	218.0	152.3	182.9	213.5	147.7	178.0	208.4	141.8	171.5	201.2	135.8	164.3	192.8
		67	TC	218.0	218.0	218.0	208.7	208.7	208.7	198.7	198.7	198.7	188.2	188.2	188.2	177.1	177.1	177.1
			SHC	126.2	157.4	188.6	122.4	153.6	184.7	118.4	149.6	180.7	114.3	145.4	176.5	109.9	141.0	172.1
		72	TC	238.5	238.5	238.5	228.4	228.4	228.4	217.7	217.7	217.7	206.3	206.3	206.3	194.3	194.3	194.3
			SHC	94.7	126.1	157.5	91.0	122.4	153.8	87.2	118.5	149.8	83.1	114.4	145.7	78.9	110.1	141.4
		76	TC	–	255.9	255.9	–	245.1	245.1	–	233.6	233.6	–	221.4	221.4	–	208.5	208.5
			SHC	–	100.7	133.3	–	97.1	129.6	–	93.3	125.6	–	89.3	121.5	–	85.1	117.1
7000 CFM	EAT (wb)	58	TC	202.7	202.7	229.1	195.4	195.4	220.8	187.5	187.5	211.9	179.2	179.2	202.5	170.3	170.3	192.4
			SHC	176.4	202.7	229.1	170.0	195.4	220.8	163.1	187.5	211.9	155.9	179.2	202.5	148.1	170.3	192.4
		62	TC	204.6	204.6	234.4	196.0	196.0	228.0	187.7	187.7	220.3	179.3	179.3	210.5	170.4	170.4	200.0
			SHC	166.0	200.2	234.4	160.8	194.4	228.0	155.1	187.7	220.3	148.2	179.3	210.5	140.8	170.4	200.0
		67	TC	222.5	222.5	222.5	212.8	212.8	212.8	202.4	202.4	202.4	191.5	191.5	191.5	180.0	180.0	186.4
			SHC	133.0	168.2	203.4	129.2	164.3	199.5	125.1	160.3	195.4	120.9	156.0	191.0	116.4	151.4	186.4
		72	TC	243.3	243.3	243.3	232.7	232.7	232.7	221.6	221.6	221.6	209.9	209.9	209.9	197.4	197.4	197.4
			SHC	97.5	132.9	168.3	93.8	129.2	164.5	89.9	125.2	160.5	85.8	121.1	156.3	81.6	116.7	151.9
		76	TC	–	260.8	260.8	–	249.6	249.6	–	237.7	237.7	–	225.1	225.1	–	211.7	211.7
			SHC	–	104.4	140.8	–	100.7	137.0	–	96.9	133.0	–	92.8	128.8	–	88.5	124.4
7875 CFM	EAT (wb)	58	TC	209.6	209.6	236.8	201.8	201.8	228.1	193.6	193.6	218.8	184.8	184.8	208.9	175.5	175.5	198.3
			SHC	182.3	209.6	236.8	175.6	201.8	228.1	168.4	193.6	218.8	160.8	184.8	208.9	152.7	175.5	198.3
		62	TC	209.8	209.8	246.2	202.0	202.0	237.1	193.8	193.8	227.4	185.0	185.0	217.1	175.6	175.6	206.1
			SHC	173.4	209.8	246.2	167.0	202.0	237.1	160.1	193.8	227.4	152.9	185.0	217.1	145.1	175.6	206.1
		67	TC	226.1	226.1	226.1	216.0	216.0	216.0	205.4	205.4	209.4	194.2	194.2	204.8	182.4	182.4	199.9
			SHC	139.6	178.6	217.7	135.6	174.7	213.7	131.5	170.5	209.4	127.1	166.0	204.8	122.5	161.2	199.9
		72	TC	247.0	247.0	247.0	236.2	236.2	236.2	224.7	224.7	224.7	212.7	212.7	212.7	199.9	199.9	199.9
			SHC	100.2	139.5	178.8	96.5	135.7	174.9	92.5	131.7	170.9	88.4	127.5	166.6	84.1	123.1	162.1
		76	TC	–	264.7	264.7	–	253.1	253.1	–	240.9	240.9	–	227.9	227.9	–	–	–
			SHC	–	107.9	148.1	–	104.2	144.3	–	100.2	140.2	–	96.1	135.9	–	–	–
8750 CFM	EAT (wb)	58	TC	215.4	215.4	243.4	207.3	207.3	234.3	198.7	198.7	224.6	189.6	189.6	214.2	179.9	179.9	203.2
			SHC	187.4	215.4	243.4	180.3	207.3	234.3	172.9	198.7	224.6	164.9	189.6	214.2	156.5	179.9	203.2
		62	TC	215.5	215.5	253.0	207.5	207.5	243.5	198.9	198.9	233.4	189.7	189.7	222.7	180.0	180.0	211.2
			SHC	178.1	215.5	253.0	171.5	207.5	243.5	164.4	198.9	233.4	156.8	189.7	222.7	148.8	180.0	211.2
		67	TC	228.9	228.9	231.5	218.7	218.7	227.3	207.8	207.8	222.8	196.4	196.4	217.9	184.5	184.5	212.6
			SHC	145.8	188.6	231.5	141.8	184.5	227.3	137.5	180.1	222.8	133.0	175.5	217.9	128.2	170.4	212.6
		72	TC	250.1	250.1	250.1	239.0	239.0	239.0	227.3	227.3	227.3	214.9	214.9	214.9	201.8	201.8	201.8
			SHC	102.8	145.8	188.9	99.0	142.0	185.0	95.0	137.9	180.9	90.8	133.7	176.5	86.4	129.2	172.0
		76	TC	–	267.8	267.8	–	256.0	256.0	–	243.5	243.5	–	230.2	230.2	–	–	–
			SHC	–	111.2	155.2	–	107.4	151.3	–	103.5	147.1	–	99.3	142.8	–	–	–

LEGEND:

- Do not operate
- Cfm – Cubic feet per minute (supply air)
- EAT(db) – Entering air temperature (dry bulb)
- EAT(wb) – Entering air temperature (wet bulb)
- SHC – Sensible heat capacity
- TC – Total capacity

Table 8 – COOLING CAPACITIES WITH HOT GAS REHEAT 17.5 TONS (2 Stage Cooling)

RAH210/213 (17.5 TONS) – UNIT WITH HOT GAS REHEAT IN SUBCOOLING MODE										
Temp (F) Air Ent Condenser (Edb)		AIR ENTERING EVAPORATOR – CFM								
		5,250			7,000			8,750		
		Air Entering Evaporator --- Ewb (F)								
		72	67	62	72	67	62	72	67	62
75	TC	232.0	211.3	190.6	242.4	221.0	199.7	250.7	228.9	207.0
	SHC	110.9	133.7	156.4	127.6	150.3	173.0	141.1	163.7	186.4
	kW	12.45	12.16	11.81	12.74	12.41	12.02	12.93	12.51	12.18
85	TC	215.9	195.7	175.5	226.0	205.2	184.4	234.2	212.8	191.5
	SHC	90.6	118.8	147.0	108.4	136.6	164.9	122.7	151.0	179.2
	kW	13.48	13.20	12.88	13.77	13.47	13.07	13.96	13.58	13.23
95	TC	199.7	180.0	160.3	209.7	189.4	169.1	217.6	196.8	176.1
	SHC	70.3	104.0	137.7	89.2	123.0	156.7	104.4	138.2	172.1
	kW	14.60	14.25	13.94	14.89	14.51	14.15	15.08	14.63	14.31
105	TC	183.6	164.5	145.2	193.3	173.5	153.8	201.0	180.8	160.6
	SHC	50.0	89.1	128.3	70.0	109.3	148.6	86.0	125.5	158.6
	kW	15.64	15.36	15.01	15.93	15.60	15.21	16.12	15.72	15.37
115	TC	167.5	148.8	130.1	176.9	157.7	138.5	184.5	164.8	145.1
	SHC	29.7	74.3	118.9	50.7	95.6	138.1	67.7	112.7	145.1
	kW	16.70	16.38	15.82	16.98	16.63	16.03	17.17	16.75	16.19
125	TC	151.4	133.2	115.0	160.6	141.9	123.1	167.9	148.8	129.7
	SHC	9.4	59.5	109.6	31.5	81.9	123.0	49.3	100.0	129.7
	kW	17.71	17.39	17.09	18.01	17.65	17.30	18.20	17.76	17.46

RAH210/213 (17.5 TONS) – UNIT WITH HOT GAS REHEAT IN HOT GAS REHEAT MODE										
Temp (F) Air Ent Condenser (Edb)		AIR ENTERING EVAPORATOR – Ewb (F)								
		75 Dry Bulb 62.5 Wet Bulb (50% Relative)			75 Dry Bulb 64 Wet Bulb (56% Relative)			75 Dry Bulb 65.3 Wet Bulb (60% Relative)		
		Air Entering Evaporator – Cfm								
		5,250	7,000	8,750	5,250	7,000	8,750	5,250	7,000	8,750
		80	TC	67.80	71.30	74.10	70.50	74.80	79.80	73.30
SHC	9.00		26.50	41.70	2.20	13.20	26.90	-5.20	2.90	13.80
kW	11.65		11.75	11.87	11.82	11.90	11.98	11.93	12.10	12.19
75	TC	72.50	76.00	78.80	75.00	79.20	84.30	78.00	83.00	86.90
	SHC	13.40	30.90	46.10	6.50	18.00	31.30	-2.10	7.20	17.90
	kW	11.44	11.54	11.66	11.61	11.68	11.75	11.70	11.86	11.95
70	TC	77.10	80.60	83.40	79.50	83.90	88.90	82.40	87.30	91.10
	SHC	17.60	34.70	49.90	10.80	22.20	35.10	3.20	11.50	22.20
	kW	11.22	11.33	11.45	11.40	11.46	11.54	11.49	11.64	11.75
60	TC	86.30	89.90	92.70	88.80	93.20	98.20	91.70	96.60	100.50
	SHC	26.20	43.20	58.40	19.40	30.80	43.60	11.60	20.10	30.70
	kW	10.76	10.86	10.98	10.93	11.00	11.07	11.03	11.18	11.28
50	TC	95.50	99.10	101.90	98.00	102.40	107.40	101.00	106.00	109.80
	SHC	34.80	51.80	67.00	28.00	39.40	52.20	20.10	28.70	39.40
	kW	10.33	10.43	10.55	10.50	10.52	10.63	10.59	10.74	10.85
40	TC	104.80	108.40	111.20	107.30	111.70	116.60	110.30	115.30	119.10
	SHC	43.40	60.40	75.60	36.60	48.00	60.80	28.80	37.30	47.90
	kW	9.87	9.97	10.09	10.04	10.11	10.18	10.14	10.28	10.40

LEGEND

- Edb** – Entering Dry–Bulb
- Ewb** – Entering Wet–Bulb
- kW** – Compressor Motor Power Input
- ldb** – Leaving Dry–Bulb
- lwb** – Leaving Wet–Bulb
- SHC** – Sensible Heat Capacity (1000 Btuh) Gross
- TC** – Total Capacity (1000 Btuh) Gross

NOTES:

- 1. Direct interpolation is permissible. Do not extrapolate.
- 1. The following formulas may be used:

$$t_{ldb} = t_{edb} - \frac{\text{sensible capacity (Btuh)}}{1.10 \times \text{cfm}}$$

$$t_{lwb} = \text{Wet–bulb temperature corresponding to enthalpy of air leaving evaporator coil (} h_{lwb} \text{)}$$

$$h_{lwb} = h_{ewb} - \frac{\text{total capacity (Btuh)}}{4.5 \times \text{cfm}}$$

Where: h_{ewb} = Enthalpy of air entering evaporator coil

TABLE 9 – COOLING CAPACITIES 20 TONS (2 Stage Cooling)

RAH240/243				AMBIENT TEMPERATURE														
				85			95			105			115			125		
				EA (dB)			EA (dB)			EA (dB)			EA (dB)			EA (dB)		
				75	80	85	75	80	85	75	80	85	75	80	85	75	80	85
6000 CFM	EAT (wb)	58	TC	214.4	214.4	242.5	207.0	207.0	234.2	118.0	118.0	143.5	190.2	190.2	215.2	180.6	180.6	204.3
			SHC	186.3	214.4	242.5	179.9	207.0	234.2	92.5	118.0	143.5	165.3	190.2	215.2	157.0	180.6	204.3
		62	TC	226.8	226.8	227.7	217.3	217.3	223.0	120.7	120.7	147.0	195.8	195.8	212.5	183.7	183.7	206.4
			SHC	167.0	197.3	227.7	162.4	192.7	223.0	83.2	115.1	147.0	152.3	182.4	212.5	146.6	176.5	206.4
		67	TC	248.4	248.4	248.4	237.9	237.9	237.9	137.4	137.4	137.4	214.3	214.3	214.3	201.0	201.0	201.0
			SHC	136.5	167.1	197.6	132.2	162.7	193.2	66.4	98.7	131.1	122.5	152.9	183.4	117.2	147.6	178.0
		72	TC	271.9	271.9	271.9	260.3	260.3	260.3	155.8	155.8	155.8	234.5	234.5	234.5	220.1	220.1	220.1
			SHC	105.1	136.0	167.0	100.8	131.7	162.5	48.7	81.1	113.5	91.4	122.1	152.9	86.3	116.9	147.6
		76	TC	–	291.7	291.7	–	279.2	279.2	–	168.8	168.8	–	251.3	251.3	–	235.8	235.8
			SHC	–	110.7	143.7	–	106.5	139.5	–	65.6	98.6	–	97.2	129.7	–	92.1	124.3
7000 CFM	EAT (wb)	58	TC	225.8	225.8	255.3	217.8	217.8	246.3	126.2	126.2	153.5	199.6	199.6	225.7	189.2	189.2	214.0
			SHC	196.2	225.8	255.3	189.3	217.8	246.3	99.0	126.2	153.5	173.4	199.6	225.7	164.4	189.2	214.0
		62	TC	233.9	233.9	248.8	223.8	223.8	243.8	126.8	126.8	160.9	201.4	201.4	231.8	190.0	190.0	221.5
			SHC	179.4	214.1	248.8	174.6	209.2	243.8	89.3	125.1	160.9	163.7	197.8	231.8	155.9	188.7	221.5
		67	TC	255.7	255.7	255.7	244.6	244.6	244.6	142.4	142.4	145.3	219.6	219.6	219.6	205.7	205.7	205.7
			SHC	144.7	179.7	214.8	140.2	175.2	210.2	70.3	107.8	145.3	130.3	165.2	200.2	124.9	159.8	194.7
		72	TC	279.4	279.4	279.4	267.3	267.3	267.3	160.9	160.9	160.9	240.1	240.1	240.1	224.9	224.9	224.9
			SHC	108.7	144.1	179.6	104.3	139.7	175.1	49.3	86.9	124.4	94.7	129.9	165.1	89.5	124.6	159.7
		76	TC	–	299.4	299.4	–	286.2	286.2	–	172.1	172.1	–	256.9	256.9	–	240.7	240.7
			SHC	–	115.3	152.9	–	110.9	148.2	–	68.2	106.2	–	101.3	138.0	–	96.1	132.6
8000 CFM	EAT (wb)	58	TC	235.3	235.3	266.2	226.8	226.8	256.5	133.2	133.2	161.9	207.4	207.4	234.5	196.3	196.3	222.0
			SHC	204.5	235.3	266.2	197.1	226.8	256.5	104.5	133.2	161.9	180.2	207.4	234.5	170.6	196.3	222.0
		62	TC	239.7	239.7	268.1	229.4	229.4	262.0	133.4	133.4	171.8	208.3	208.3	241.9	196.7	196.7	231.0
			SHC	190.7	229.4	268.1	185.4	223.7	262.0	95.0	133.4	171.8	170.4	206.2	241.9	162.3	196.7	231.0
		67	TC	261.3	261.3	261.3	249.6	249.6	249.6	146.4	146.4	159.1	223.6	223.6	223.6	209.2	209.2	210.6
			SHC	152.3	191.8	231.2	147.7	187.1	226.6	73.9	116.5	159.1	137.7	177.0	216.3	132.2	171.4	210.6
		72	TC	285.3	285.3	285.3	272.5	272.5	272.5	164.6	164.6	164.6	244.2	244.2	244.2	228.6	228.6	228.6
			SHC	111.9	151.7	191.5	107.5	147.2	186.9	49.7	92.1	134.5	97.7	137.2	176.7	92.4	131.8	171.2
		76	TC	–	305.4	305.4	–	291.6	291.6	–	174.2	174.2	–	261.2	261.2	–	244.4	244.4
			SHC	–	119.4	161.0	–	114.9	156.2	–	70.5	113.0	–	105.1	146.0	–	99.8	140.4
9000 CFM	EAT (wb)	58	TC	243.5	243.5	275.4	234.5	234.5	265.2	139.2	139.2	169.2	213.9	213.9	241.9	202.3	202.3	228.8
			SHC	211.6	243.5	275.4	203.8	234.5	265.2	109.1	139.2	169.2	185.9	213.9	241.9	175.8	202.3	228.8
		62	TC	245.4	245.4	282.9	235.4	235.4	274.6	139.4	139.4	179.5	214.4	214.4	251.7	202.5	202.5	237.8
			SHC	199.7	241.3	282.9	193.2	233.9	274.6	99.2	139.4	179.5	176.8	214.3	251.7	167.1	202.5	237.8
		67	TC	265.6	265.6	265.6	253.6	253.6	253.6	149.5	149.5	172.3	226.8	226.8	231.8	212.0	212.0	225.8
			SHC	159.6	203.3	247.1	154.9	198.6	242.3	77.2	124.7	172.3	144.7	188.3	231.8	139.0	182.4	225.8
		72	TC	289.9	289.9	289.9	276.7	276.7	276.7	166.9	166.9	166.9	247.5	247.5	247.5	231.4	231.4	231.4
			SHC	114.9	159.0	203.0	110.4	154.4	198.3	49.7	96.7	143.7	100.5	144.2	188.0	95.2	138.7	182.3
		76	TC	–	310.1	310.1	–	295.8	295.8	–	175.6	175.6	–	264.4	264.4	–	247.3	247.3
			SHC	–	123.2	168.9	–	118.6	164.1	–	72.4	118.9	–	108.7	153.6	–	103.4	147.9
10,000 CFM	EAT (wb)	58	TC	250.4	250.4	283.2	240.9	240.9	272.5	144.4	144.4	175.5	219.5	219.5	248.2	207.3	207.3	234.5
			SHC	217.7	250.4	283.2	209.4	240.9	272.5	113.2	144.4	175.5	190.7	219.5	248.2	180.2	207.3	234.5
		62	TC	250.8	250.8	294.6	241.1	241.1	283.3	144.6	144.6	186.2	219.6	219.6	258.0	207.5	207.5	243.7
			SHC	207.0	250.8	294.6	199.0	241.1	283.3	103.0	144.6	186.2	181.2	219.6	258.0	171.2	207.5	243.7
		67	TC	269.2	269.2	269.2	256.8	256.8	257.6	152.3	152.3	185.0	229.4	229.4	246.4	214.3	214.3	240.0
			SHC	166.6	214.5	262.5	161.9	209.7	257.6	80.4	132.7	185.0	151.3	198.9	246.4	145.5	192.8	240.0
		72	TC	293.7	293.7	293.7	280.1	280.1	280.1	168.6	168.6	168.6	250.2	250.2	250.2	233.7	233.7	233.7
			SHC	117.8	166.0	214.2	113.2	161.3	209.3	49.7	101.0	152.4	103.2	151.0	198.8	97.8	145.4	193.1
		76	TC	–	313.9	313.9	–	299.3	299.3	–	176.8	176.8	–	267.1	267.1	–	249.6	249.6
			SHC	–	126.8	176.5	–	122.2	171.6	–	74.3	124.7	–	112.1	161.0	–	106.7	155.1

LEGEND:

- Do not operate
- Cfm – Cubic feet per minute (supply air)
- EAT(db) – Entering air temperature (dry bulb)
- EAT(wb) – Entering air temperature (wet bulb)
- SHC – Sensible heat capacity
- TC – Total capacity

Table 9 – COOLING CAPACITIES WITH HOT GAS REHEAT 20 TONS (2 Stage Cooling)

RAH240/243 (20 TONS) – UNIT WITH HOT GAS REHEAT IN SUBCOOLING MODE										
Temp (F) Air Ent Condenser (Edb)		AIR ENTERING EVAPORATOR – CFM								
		6,000			8,000			10,000		
		Air Entering Evaporator --- Ewb (F)								
		72	67	62	72	67	62	72	67	62
75	TC	281.6	256.5	231.3	293.1	267.0	240.9	302.3	275.4	248.6
	SHC	114.7	141.0	167.4	140.6	166.6	192.6	161.6	187.3	212.9
	kW	13.52	13.25	12.95	13.82	13.46	13.21	13.97	13.60	13.31
85	TC	261.3	236.9	212.4	272.1	247.7	221.3	280.7	254.6	228.5
	SHC	90.9	123.5	156.1	118.8	151.1	183.3	141.4	173.4	205.4
	kW	14.95	14.68	14.48	15.25	14.89	14.64	15.40	15.03	14.74
95	TC	241.1	217.2	193.4	251.1	226.4	201.7	259.2	233.8	208.4
	SHC	67.2	106.0	144.8	97.1	120.1	174.1	121.2	159.5	197.8
	kW	16.52	16.25	15.95	16.82	16.46	16.21	16.97	16.60	16.31
105	TC	220.8	197.5	174.4	230.2	206.2	182.2	237.7	213.0	188.4
	SHC	43.4	88.4	133.5	75.3	120.1	164.9	101.0	145.7	178.9
	kW	18.09	17.82	17.52	18.39	18.03	17.78	18.54	18.17	17.88
115	TC	200.5	178.0	155.5	209.2	185.9	162.6	216.2	192.2	168.7
	SHC	19.7	70.9	122.2	53.5	104.6	155.7	80.9	131.8	161.2
	kW	19.65	19.38	19.08	19.95	19.59	19.34	20.10	19.73	19.44
125	TC	180.2	158.4	136.5	188.2	165.6	143.0	194.7	171.4	148.2
	SHC	-4.1	53.4	110.8	31.7	89.1	142.2	60.7	118.0	145.1
	kW	20.59	20.32	20.02	20.89	20.53	20.28	21.04	20.67	20.38

RAH240/243 (20 TONS) – UNIT WITH HOT GAS REHEAT IN HOT GAS REHEAT MODE										
Temp (F) Air Ent Condenser (Edb)		AIR ENTERING EVAPORATOR – Ewb (F)								
		75 Dry Bulb 62.5 Wet Bulb (50% Relative)			75 Dry Bulb 64 Wet Bulb (56% Relative)			75 Dry Bulb 65.3 Wet Bulb (60% Relative)		
		Air Entering Evaporator – Cfm								
		6,000	8,000	10,000	6,000	8,000	10,000	6,000	8,000	10,000
		80	TC	115.20	123.30	130.60	120.40	129.30	138.20	122.80
SHC	40.80		58.30	76.10	32.30	45.50	60.40	20.10	34.30	48.00
kW	13.24		13.32	13.39	13.43	13.57	13.65	13.49	13.68	13.74
75	TC	119.80	128.60	135.90	125.50	135.30	143.20	128.00	139.50	148.40
	SHC	45.60	62.80	82.10	37.00	49.80	65.20	24.30	38.70	52.60
	kW	13.05	13.10	13.17	13.21	13.35	13.43	13.27	13.46	13.52
70	TC	122.50	133.10	140.20	129.80	140.70	147.60	132.40	144.40	153.20
	SHC	49.80	76.00	86.10	41.10	54.30	69.20	28.80	41.40	56.80
	kW	12.80	12.87	12.94	12.98	13.12	13.20	13.04	13.23	13.29
60	TC	133.80	142.50	149.60	139.30	150.40	157.40	141.50	154.20	163.00
	SHC	58.60	76.00	95.00	50.20	63.50	78.10	37.80	52.10	65.90
	kW	12.34	12.42	12.49	12.53	12.67	12.75	12.59	12.78	12.84
50	TC	143.50	151.80	159.30	149.00	160.00	167.00	151.30	163.60	172.50
	SHC	67.70	84.80	103.80	59.10	72.40	87.00	46.70	61.00	74.90
	kW	11.88	11.95	12.03	12.07	12.21	12.29	12.13	12.32	12.38
40	TC	153.20	161.30	168.70	158.60	169.20	176.60	160.80	173.10	182.00
	SHC	76.50	93.60	111.60	68.00	81.50	95.80	55.80	69.80	84.00
	kW	11.42	11.49	11.56	11.60	11.74	11.82	11.66	11.85	11.91

LEGEND

- Edb** – Entering Dry–Bulb
- Ewb** – Entering Wet–Bulb
- kW** – Compressor Motor Power Input
- ldb** – Leaving Dry–Bulb
- lwb** – Leaving Wet–Bulb
- SHC** – Sensible Heat Capacity (1000 Btuh) Gross
- TC** – Total Capacity (1000 Btuh) Gross

NOTES:

1. Direct interpolation is permissible. Do not extrapolate.
1. The following formulas may be used:

$$t_{ldb} = t_{edb} - \frac{\text{sensible capacity (Btuh)}}{1.10 \times \text{cfm}}$$

$$t_{lwb} = \text{Wet–bulb temperature corresponding to enthalpy of air leaving evaporator coil (} h_{lwb} \text{)}$$

$$h_{lwb} = h_{ewb} - \frac{\text{total capacity (Btuh)}}{4.5 \times \text{cfm}}$$

Where: h_{ewb} = Enthalpy of air entering evaporator coil

TABLE 10 – COOLING CAPACITIES 25 TONS (2 Stage Cooling)

RAH300/303				AMBIENT TEMPERATURE														
				85			95			105			115			125		
				EA (dB)			EA (dB)			EA (dB)			EA (dB)			EA (dB)		
				75	80	85	75	80	85	75	80	85	75	80	85	75	80	85
7,500 CFM	EAT (wb)	58	TC	264.4	264.4	298.9	254.6	254.6	287.9	244.1	244.1	276.0	232.7	232.7	263.1	220.3	220.3	249.1
			SHC	229.9	264.4	298.9	221.4	254.6	287.9	212.2	244.1	276.0	202.3	232.7	263.1	191.5	220.3	249.1
		62	TC	278.7	278.7	282.4	266.3	266.3	276.4	252.8	252.8	269.8	238.5	238.5	262.4	223.9	223.9	251.3
			SHC	206.8	244.6	282.4	200.9	238.7	276.4	194.6	232.2	269.8	187.7	225.0	262.4	178.7	215.0	251.3
		67	TC	305.3	305.3	305.3	291.9	291.9	291.9	277.3	277.3	277.3	261.5	261.5	261.5	244.5	244.5	244.5
			SHC	169.0	207.0	245.0	163.4	201.4	239.4	157.4	195.3	233.3	151.0	188.9	226.8	144.2	182.1	219.9
		72	TC	334.0	334.0	334.0	319.4	319.4	319.4	303.6	303.6	303.6	286.5	286.5	286.5	268.1	268.1	268.1
			SHC	129.9	168.5	207.1	124.5	163.0	201.5	118.7	157.1	195.5	112.5	150.8	189.2	106.0	144.2	182.3
		76	TC	–	358.2	358.2	–	342.4	342.4	–	325.4	325.4	–	307.1	307.1	–	287.4	287.4
			SHC	–	137.0	178.2	–	131.7	172.9	–	126.0	166.9	–	119.9	160.4	–	113.4	153.4
8,750 CFM	EAT (wb)	58	TC	278.2	278.2	314.5	267.8	267.8	302.8	256.5	256.5	289.9	244.2	244.2	276.1	230.8	230.8	261.0
			SHC	241.9	278.2	314.5	232.8	267.8	302.8	223.0	256.5	289.9	212.3	244.2	276.1	200.7	230.8	261.0
		62	TC	287.2	287.2	308.3	274.3	274.3	301.5	260.8	260.8	291.7	247.0	247.0	280.9	232.0	232.0	269.1
			SHC	222.1	265.2	308.3	215.7	258.6	301.5	207.7	249.7	291.7	199.0	240.0	280.9	189.7	229.4	269.1
		67	TC	314.0	314.0	314.0	299.8	299.8	299.8	284.4	284.4	284.4	267.8	267.8	267.8	250.0	250.0	250.0
			SHC	179.1	222.7	266.4	173.3	216.9	260.6	167.2	210.8	254.3	160.7	204.2	247.7	153.7	197.2	240.6
		72	TC	343.0	343.0	343.0	327.7	327.7	327.7	311.1	311.1	311.1	293.1	293.1	293.1	273.8	273.8	273.8
			SHC	134.3	178.5	222.6	128.8	172.9	216.9	122.9	166.9	210.8	116.6	160.4	204.3	109.9	153.6	197.3
		76	TC	–	367.3	367.3	–	350.8	350.8	–	333.0	333.0	–	313.8	313.8	–	293.2	293.2
			SHC	–	142.6	189.4	–	137.1	183.5	–	131.2	177.3	–	125.0	170.7	–	118.4	163.7
10,000 CFM	EAT (wb)	58	TC	289.7	289.7	327.5	278.7	278.7	315.0	266.6	266.6	301.4	253.6	253.6	286.7	239.4	239.4	270.7
			SHC	251.9	289.7	327.5	242.3	278.7	315.0	231.8	266.6	301.4	220.5	253.6	286.7	208.2	239.4	270.7
		62	TC	294.6	294.6	329.6	282.2	282.2	319.7	268.7	268.7	309.1	254.1	254.1	298.4	239.7	239.7	281.4
			SHC	234.7	282.1	329.6	226.8	273.3	319.7	218.4	263.7	309.1	209.7	254.1	298.4	197.9	239.7	281.4
		67	TC	320.6	320.6	320.6	305.9	305.9	305.9	289.9	289.9	289.9	272.7	272.7	272.7	254.3	254.3	260.3
			SHC	188.6	237.7	286.8	182.7	231.8	280.9	176.5	225.5	274.5	169.8	218.8	267.7	162.8	211.5	260.3
		72	TC	350.0	350.0	350.0	334.0	334.0	334.0	316.8	316.8	316.8	298.2	298.2	298.2	278.3	278.3	278.3
			SHC	138.4	187.9	237.5	132.8	182.2	231.7	126.8	176.1	225.5	120.4	169.6	218.8	113.6	162.6	211.7
		76	TC	–	374.4	374.4	–	357.3	357.3	–	338.7	338.7	–	318.9	318.9	–	297.5	297.5
			SHC	–	147.7	199.5	–	142.1	193.7	–	136.1	187.4	–	129.7	180.6	–	123.0	173.5
11,250 CFM	EAT (wb)	58	TC	299.4	299.4	338.4	287.8	287.8	325.4	275.2	275.2	311.1	261.4	261.4	295.6	246.6	246.6	278.8
			SHC	260.3	299.4	338.4	250.2	287.8	325.4	239.2	275.2	311.1	227.3	261.4	295.6	214.4	246.6	278.8
		62	TC	302.2	302.2	346.0	289.3	289.3	335.7	275.5	275.5	323.5	262.1	262.1	307.7	246.8	246.8	289.8
			SHC	244.8	295.4	346.0	236.7	286.2	335.7	227.5	275.5	323.5	216.4	262.1	307.7	203.8	246.8	289.8
		67	TC	325.9	325.9	325.9	310.7	310.7	310.7	294.2	294.2	294.2	276.6	276.6	286.7	257.7	257.7	278.9
			SHC	197.6	252.1	306.5	191.7	246.1	300.4	185.3	239.6	293.9	178.5	232.6	286.7	171.2	225.1	278.9
		72	TC	355.5	355.5	355.5	339.1	339.1	339.1	321.3	321.3	321.3	302.2	302.2	302.2	281.8	281.8	281.8
			SHC	142.1	197.0	251.8	136.4	191.2	245.9	130.4	185.0	239.6	123.9	178.3	232.8	117.1	171.3	225.5
		76	TC	–	380.0	380.0	–	362.4	362.4	–	343.3	343.3	–	322.8	322.8	–	300.9	300.9
			SHC	–	152.4	209.4	–	146.8	203.4	–	140.7	197.0	–	134.2	190.2	–	127.3	182.8
12,500 CFM	EAT (wb)	58	TC	307.7	307.7	347.9	295.7	295.7	334.2	282.5	282.5	319.3	268.2	268.2	303.2	252.7	252.7	285.7
			SHC	267.6	307.7	347.9	257.1	295.7	334.2	245.6	282.5	319.3	233.2	268.2	303.2	219.7	252.7	285.7
		62	TC	308.4	308.4	362.2	295.9	295.9	347.4	283.1	283.1	332.4	268.4	268.4	315.2	252.8	252.8	296.9
			SHC	254.6	308.4	362.2	244.4	295.9	347.4	233.8	283.1	332.4	221.7	268.4	315.2	208.8	252.8	296.9
		67	TC	330.2	330.2	330.2	314.6	314.6	319.2	297.8	297.8	312.3	279.8	279.8	304.7	260.6	260.6	295.9
			SHC	206.3	265.9	325.5	200.3	259.7	319.2	193.8	253.1	312.3	186.7	245.7	304.7	179.0	237.4	295.9
		72	TC	360.1	360.1	360.1	343.2	343.2	343.2	325.0	325.0	325.0	305.4	305.4	305.4	284.6	284.6	284.6
			SHC	145.7	205.7	265.7	139.9	199.8	259.7	133.8	193.5	253.3	127.3	186.8	246.3	120.4	179.7	238.9
		76	TC	–	384.6	384.6	–	366.5	366.5	–	346.9	346.9	–	325.9	325.9	–	303.5	303.5
			SHC	–	157.0	218.9	–	151.2	212.9	–	145.1	206.3	–	138.5	199.3	–	131.5	191.7

LEGEND:

- Do not operate
- Cfm – Cubic feet per minute (supply air)
- EAT(db) – Entering air temperature (dry bulb)
- EAT(wb) – Entering air temperature (wet bulb)
- SHC – Sensible heat capacity
- TC – Total capacity

Table 10 – COOLING CAPACITIES WITH HOT GAS REHEAT 25 TONS (2 Stage Cooling)

RAH300/303 (25 TONS) – UNIT WITH HOT GAS REHEAT IN SUBCOOLING MODE										
Temp (F) Air Ent Condenser (Edb)		AIR ENTERING EVAPORATOR – CFM								
		7,500			10,000			12,500		
		Air Entering Evaporator --- Ewb (F)								
		72	67	62	72	67	62	72	67	62
75	TC	351.3	319.5	287.8	370.4	337.3	304.1	385.8	351.5	317.2
	SHC	166.5	199.4	232.3	191.2	245.6	258.5	211.4	245.6	279.9
	kW	16.75	16.55	15.20	17.30	16.75	15.85	17.80	17.50	16.50
85	TC	327.5	296.4	265.3	346.1	313.6	281.2	361.1	327.5	294.0
	SHC	137.4	178.2	219.0	162.6	204.5	246.4	183.3	226.0	268.7
	kW	18.65	18.45	17.25	19.20	18.65	17.80	19.45	19.15	18.15
95	TC	303.7	273.3	242.9	321.8	290.0	258.3	336.4	303.5	270.7
	SHC	108.2	157.0	205.8	134.0	184.1	234.3	155.1	206.4	257.6
	kW	20.60	20.40	19.34	21.15	20.60	19.95	21.60	21.30	20.30
105	TC	279.9	250.2	220.4	297.5	266.4	235.3	311.7	279.5	247.4
	SHC	79.0	135.8	192.5	105.4	163.8	222.2	127.1	186.7	246.4
	kW	22.85	22.65	21.45	23.40	22.85	22.05	23.70	23.40	22.40
115	TC	256.2	227.1	198.0	273.2	242.8	212.4	287.0	255.5	224.1
	SHC	49.9	114.5	179.2	76.8	143.4	210.1	98.9	167.1	223.8
	kW	25.05	24.85	23.65	25.60	25.05	24.25	25.90	25.60	24.60
125	TC	232.4	203.9	175.5	248.9	219.2	189.5	262.3	231.5	200.8
	SHC	20.7	93.3	166.0	48.2	123.1	188.9	70.8	147.4	200.8
	kW	27.25	27.05	25.80	27.80	27.25	26.50	28.15	27.85	26.85

RAH300/303 (25 TONS) – UNIT WITH HOT GAS REHEAT IN HOT GAS REHEAT MODE										
Temp (F) Air Ent Condenser (Edb)		AIR ENTERING EVAPORATOR – Ewb (F)								
		75 Dry Bulb 62.5 Wet Bulb (50% Relative)			75 Dry Bulb 64 Wet Bulb (56% Relative)			75 Dry Bulb 65.3 Wet Bulb (60% Relative)		
		Air Entering Evaporator – Cfm								
		7,500	10,000	12,500	7,500	10,000	12,500	7,500	10,000	12,500
		80	TC	124.40	133.90	139.00	132.00	142.10	145.10	135.60
SHC	37.60		60.70	82.20	27.80	45.40	65.80	17.50	34.20	50.10
kW	15.83		15.90	16.00	15.97	16.13	16.16	16.11	16.31	16.38
75	TC	129.00	138.50	144.60	136.60	147.60	150.10	140.60	154.00	156.30
	SHC	47.10	70.60	92.10	37.30	55.30	75.70	27.00	43.70	60.00
	kW	15.77	15.83	15.94	15.91	16.07	16.10	16.05	16.25	16.32
70	TC	133.60	143.10	149.20	141.20	152.30	154.80	145.30	158.80	161.10
	SHC	57.30	80.70	102.20	47.50	65.40	85.80	37.20	53.90	70.10
	kW	15.68	15.75	15.86	15.83	16.00	16.04	15.88	16.08	16.15
60	TC	142.80	158.40	158.40	150.40	161.40	163.90	153.90	167.40	169.70
	SHC	76.50	121.40	121.40	66.70	84.60	105.00	56.40	73.10	89.30
	kW	15.54	15.60	15.71	15.68	15.84	15.87	15.82	16.02	16.09
50	TC	151.80	161.30	167.40	159.40	170.50	173.20	162.80	176.20	178.80
	SHC	94.10	117.50	139.00	84.30	102.20	122.60	74.00	90.70	106.90
	kW	15.40	15.47	15.58	15.54	15.68	15.71	15.66	15.86	15.93
40	TC	161.20	170.70	176.80	168.80	179.80	182.50	172.20	185.70	188.20
	SHC	114.10	137.60	159.10	104.30	122.30	142.70	94.00	110.70	127.00
	kW	15.24	15.31	15.42	15.39	15.55	15.58	15.53	15.73	15.80

LEGEND

- Edb** – Entering Dry–Bulb
- Ewb** – Entering Wet–Bulb
- kW** – Compressor Motor Power Input
- ldb** – Leaving Dry–Bulb
- lwb** – Leaving Wet–Bulb
- SHC** – Sensible Heat Capacity (1000 Btuh) Gross
- TC** – Total Capacity (1000 Btuh) Gross

NOTES:

1. Direct interpolation is permissible. Do not extrapolate.
1. The following formulas may be used:

$$t_{ldb} = t_{edb} - \frac{\text{sensible capacity (Btuh)}}{1.10 \times \text{cfm}}$$

$$t_{lwb} = \text{Wet–bulb temperature corresponding to enthalpy of air leaving evaporator coil } (h_{lwb})$$

$$h_{lwb} = h_{ewb} - \frac{\text{total capacity (Btuh)}}{4.5 \times \text{cfm}}$$

Where: h_{ewb} = Enthalpy of air entering evaporator coil

TABLE 11 – STATIC PRESSURE ADDERS (Factory Options and/or Accessories)

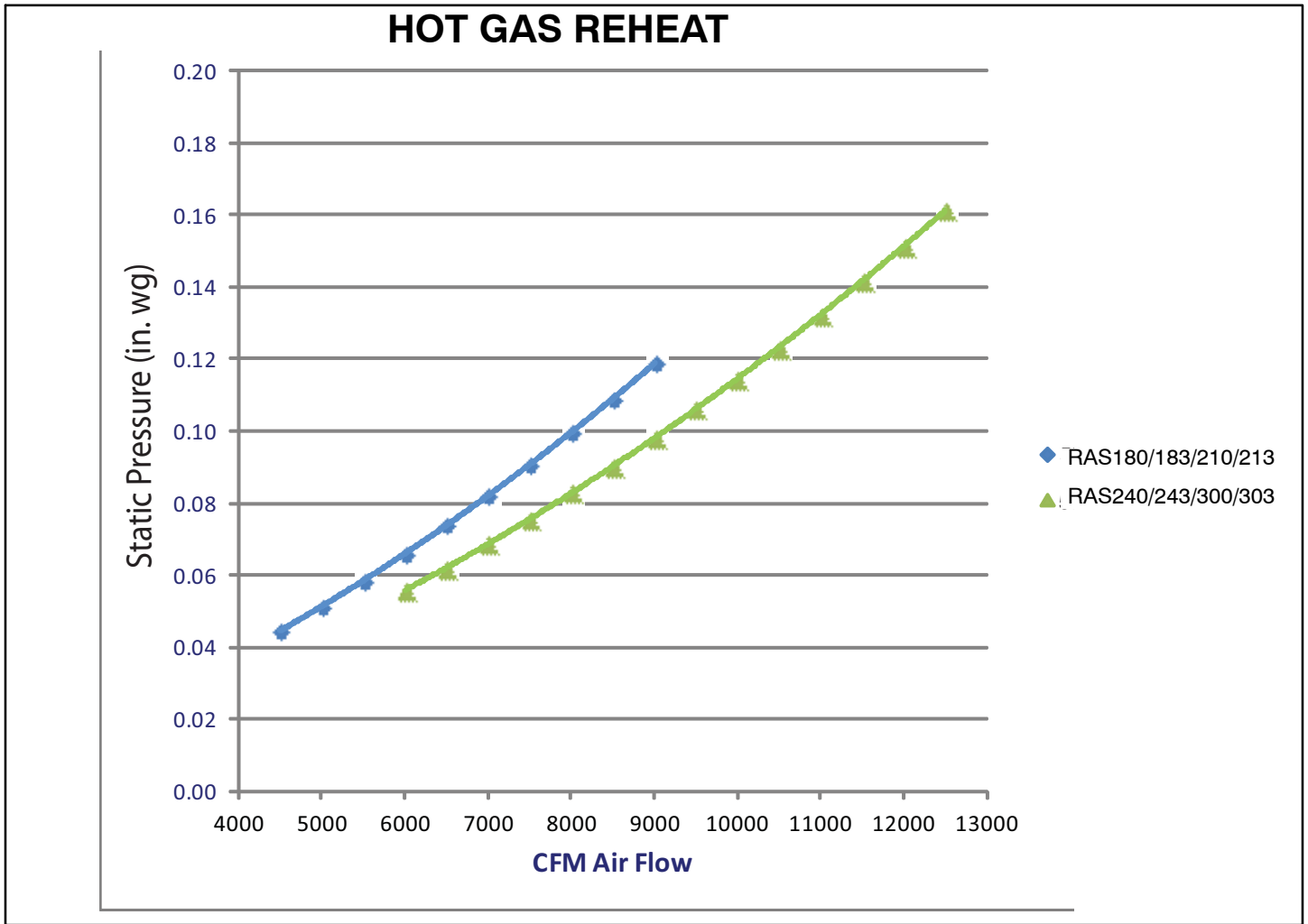

Economizer – Vertical and Horizontal Duct Configuration

Model Sizes 181 – 303								
CFM	4500	5000	5500	6000	6500	7000	7500	8000
Vertical & Horizontal	0.047	0.052	0.057	0.062	0.067	0.072	0.077	0.082

Model Sizes 181 – 303									
CFM	8500	9000	9500	10000	10500	11000	11500	12000	12500
Vertical & Horizontal	0.088	0.093	0.098	0.103	0.109	0.114	0.119	0.125	0.131

Electric Heaters – Vertical and Horizontal Duct Configuration

MODEL SIZES 181 – 303								
CFM	4500	5000	5500	6000	6500	7000	7500	8000
25 kW Heater	0.010	0.010	0.015	0.020	0.025	0.030	0.035	0.040
50 kW Heater	0.020	0.020	0.030	0.040	0.050	0.060	0.070	0.080
75 kW Heater	0.030	0.040	0.050	0.060	0.070	0.080	0.100	0.120

MODEL SIZES 181 – 303									
CFM	8500	9000	9500	10000	10500	11000	11500	12000	12500
25 kW Heater	0.045	0.050	0.055	0.060	0.070	0.080	0.090	0.100	0.105
50 kW Heater	0.090	0.100	0.120	0.130	0.150	0.160	0.180	0.200	0.230
75 kW Heater	0.140	0.150	0.180	0.200	0.230	0.250	0.270	0.300	0.330

DAMPER, BAROMETRIC RELIEF, AND PERFORMANCE, 15 to 25 Ton

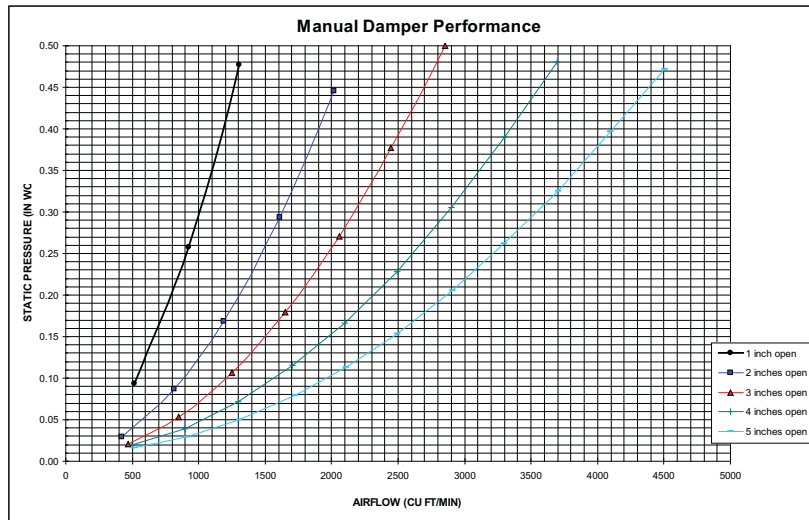

Fig 1 - Manual Damper Performance

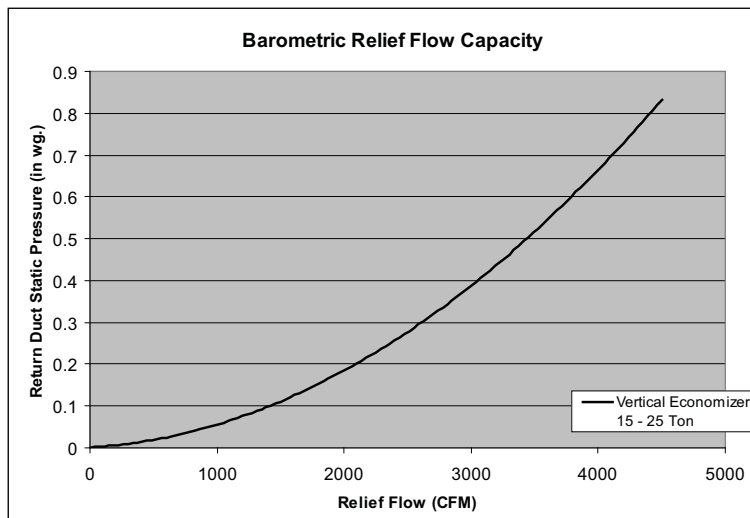

Fig 2 - Barometric Relief Flow Capacity

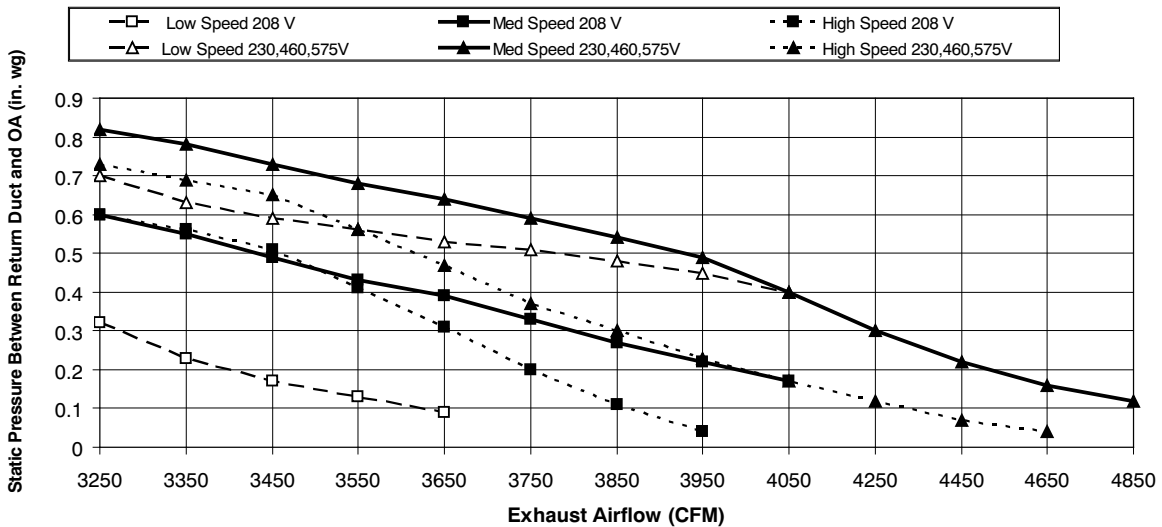

Fig 3 - Power Exhaust Fan Performance

General fan performance notes:

1. Interpolation is permissible. Do not extrapolate.
2. External static pressure is the static pressure difference between the return duct and the supply duct plus the static pressure caused by any FIOPs or accessories.
3. Tabular data accounts for pressure loss due to clean filters, high gas heat, unit casing, and wet coils. Factory options and accessories may add static pressure losses, as shown in Table 11.
4. The Fan Performance tables offer motor/drive recommendations. In cases when two motor/drive combinations would work, the lower horsepower option is recommended.
5. For information on the electrical properties of motors, please see the Electrical information section of this book.
6. For more information on the performance limits of motors, see the application data section of this book.

FAN PERFORMANCE

TABLE 12 – RAH181, 15 TON VERTICAL SUPPLY / RETURN

CFM	Available External Static Pressure (in. wg)									
	0.2		0.4		0.6		0.8		1.0	
	RPM	BHP	RPM	BHP	RPM	BHP	RPM	BHP	RPM	BHP
4500	436	0.60	530	0.90	611	1.22	684	1.57	751	1.94
4900	456	0.71	546	1.03	625	1.37	695	1.73	760	2.12
5250	473	0.83	560	1.16	637	1.51	706	1.89	770	2.30
5600	491	0.95	575	1.30	650	1.67	717	2.07	780	2.48
6000	513	1.11	593	1.48	665	1.87	731	2.28	792	2.71
6400	534	1.29	611	1.68	681	2.09	745	2.52	805	2.97
6750	553	1.46	628	1.87	696	2.29	758	2.74	817	3.20
7100	573	1.65	645	2.07	711	2.51	772	2.98	829	3.46
7500	595	1.88	665	2.33	729	2.79	788	3.27	844	3.77

CFM	Available External Static Pressure (in. wg)									
	1.2		1.4		1.6		1.8		2.0	
	RPM	BHP	RPM	BHP	RPM	BHP	RPM	BHP	RPM	BHP
4500	812	2.33	869	2.74	924	3.17	975	3.62	1024	4.08
4900	821	2.53	877	2.95	931	3.40	981	3.86	1030	4.34
5250	829	2.72	885	3.16	938	3.61	988	4.09	1036	4.57
5600	838	2.92	893	3.37	945	3.84	994	4.33	1042	4.83
6000	849	3.17	903	3.63	954	4.12	1003	4.62	-----	-----
6400	861	3.43	914	3.92	964	4.42	1012	4.94	-----	-----
6750	872	3.69	924	4.18	973	4.70	-----	-----	-----	-----
7100	883	3.95	934	4.47	-----	-----	-----	-----	-----	-----
7500	897	4.28	947	4.81	-----	-----	-----	-----	-----	-----

Std Static Motor and Drive – 514–680 RPM, Max BHP 2.29

Medium Static Motor and Drive – 679–863 RPM, Max BHP 3.3

High Static Motor and Drive – 826–1009 RPM, Max BHP 4.9

----- Outside operating range

Boldface – Field-supplied Drive

TABLE 13 – RAH210, 17.5 TON VERTICAL SUPPLY / RETURN

CFM	Available External Static Pressure (in. wg)									
	0.2		0.4		0.6		0.8		1.0	
	RPM	BHP	RPM	BHP	RPM	BHP	RPM	BHP	RPM	BHP
5250	473	0.83	560	1.16	637	1.51	706	1.89	770	2.30
5700	497	0.99	580	1.34	654	1.72	721	2.12	783	2.54
6100	518	1.15	598	1.53	669	1.92	735	2.34	795	2.78
6500	540	1.33	616	1.73	685	2.14	749	2.58	808	3.03
7000	567	1.59	640	2.01	707	2.45	768	2.91	826	3.38
7500	595	1.88	665	2.33	729	2.79	788	3.27	844	3.77
7900	618	2.14	685	2.60	747	3.09	805	3.59	859	4.10
8300	641	2.42	705	2.91	765	3.41	822	3.93	875	4.46
8750	666	2.77	729	3.28	787	3.80	842	4.34	893	4.90

CFM	Available External Static Pressure (in. wg)									
	1.2		1.4		1.6		1.8		2.0	
	RPM	BHP	RPM	BHP	RPM	BHP	RPM	BHP	RPM	BHP
5250	829	2.72	885	3.16	938	3.61	988	4.09	1036	4.57
5700	841	2.98	895	3.43	947	3.91	997	4.40	1044	4.90
6100	852	3.23	906	3.70	957	4.19	1005	4.70	1052	5.22
6500	864	3.50	917	3.99	967	4.50	1015	5.02	1060	5.55
7000	880	3.88	931	4.38	980	4.91	1027	5.45	1072	6.01
7500	897	4.28	947	4.81	995	5.36	1041	5.92	1085	6.49
7900	911	4.63	960	5.18	1007	5.75	1052	6.32	-----	-----
8300	926	5.01	974	5.58	1020	6.16	-----	-----	-----	-----
8750	943	5.47	990	6.05	-----	-----	-----	-----	-----	-----

Std Static Motor and Drive – 622–822 RPM, Max BHP 3.3

Medium Static Motor and Drive – 713–879 RPM, Max BHP 4.9

High Static Motor and Drive – 882–1078 RPM, Max BHP 6.5

----- Outside operating range

Boldface – Field-supplied Drive

FAN PERFORMANCE (cont.)

TABLE 14 – RAH240, 20 TON VERTICAL SUPPLY / RETURN

CFM	Available External Static Pressure (in. wg)									
	0.2		0.4		0.6		0.8		1.0	
	RPM	BHP	RPM	BHP	RPM	BHP	RPM	BHP	RPM	BHP
6000	506	1.12	593	1.43	668	1.74	736	2.07	798	2.40
6500	533	1.36	616	1.70	689	2.04	754	2.39	815	2.74
7000	561	1.64	640	2.01	710	2.37	774	2.74	833	3.11
7500	588	1.96	664	2.35	732	2.74	795	3.13	852	3.53
8000	617	2.32	689	2.74	755	3.15	816	3.57	872	3.99
8500	645	2.73	715	3.17	779	3.60	837	4.04	892	4.49
9000	674	3.18	741	3.64	803	4.10	860	4.57	913	5.04
9500	703	3.67	767	4.16	827	4.65	883	5.14	935	5.64
10000	732	4.22	794	4.74	852	5.25	906	5.77	957	6.29

CFM	Available External Static Pressure (in. wg)									
	1.2		1.4		1.6		1.8		2.0	
	RPM	BHP	RPM	BHP	RPM	BHP	RPM	BHP	RPM	BHP
6000	855	2.75	909	3.11	959	3.47	1008	3.85	1054	4.24
6500	871	3.11	924	3.48	974	3.87	1022	4.26	1067	4.67
7000	888	3.50	940	3.89	989	4.30	1036	4.71	1081	5.13
7500	906	3.94	957	4.35	1005	4.77	1052	5.20	1096	5.64
8000	925	4.42	975	4.85	1022	5.29	1068	5.74	1111	6.20
8500	944	4.94	993	5.40	1040	5.86	1084	6.33	1127	6.81
9000	964	5.51	1012	5.99	1058	6.48	1102	6.97	1144	7.46
9500	984	6.13	1032	6.64	1077	7.14	1120	7.65	1161	8.17
10000	1006	6.81	1052	7.33	1096	7.86	1138	8.40	-----	-----

Std Static Motor and Drive – 690–863 RPM, Max BHP 4.9 Medium Static Motor and Drive – 835–1021 RPM, Max BHP 6.5
High Static Motor and Drive – 941–1176 RPM, Max BHP 8.7 ----- Outside operating range
Boldface – Field-supplied Drive

TABLE 15 – RAH300, 25 TON VERTICAL SUPPLY / RETURN

CFM	Available External Static Pressure (in. wg)									
	0.2		0.4		0.6		0.8		1.0	
	RPM	BHP	RPM	BHP	RPM	BHP	RPM	BHP	RPM	BHP
7500	541	1.50	636	1.88	716	2.27	787	2.66	850	3.06
8000	563	1.76	656	2.17	735	2.58	804	3.00	867	3.42
8500	585	2.05	676	2.50	753	2.93	822	3.37	884	3.81
9000	608	2.37	697	2.85	772	3.31	840	3.77	901	4.24
9500	631	2.73	717	3.24	791	3.73	858	4.21	918	4.70
10000	654	3.12	738	3.66	811	4.18	876	4.69	936	5.20
10500	678	3.56	759	4.12	831	4.67	895	5.21	954	5.74
11000	701	4.02	781	4.62	851	5.20	914	5.76	972	6.33
11500	725	4.53	802	5.16	871	5.77	933	6.36	991	6.95
12000	748	5.09	824	5.75	892	6.38	953	7.00	1010	7.62
12500	772	5.68	846	6.38	912	7.04	973	7.69	1029	8.34

CFM	Available External Static Pressure (in. wg)									
	1.2		1.4		1.6		1.8		2.0	
	RPM	BHP	RPM	BHP	RPM	BHP	RPM	BHP	RPM	BHP
CFM	RPM	BHP	RPM	BHP	RPM	BHP	RPM	BHP	RPM	BHP
7500	909	3.47	963	3.89	1014	4.32	1062	4.77	1108	5.23
8000	925	3.85	978	4.29	1029	4.74	1077	5.20	1122	5.68
8500	941	4.26	994	4.72	1044	5.19	1092	5.67	1137	6.16
9000	957	4.71	1010	5.19	1060	5.67	1107	6.17	1152	6.68
9500	974	5.19	1027	5.69	1076	6.20	1123	6.72	1167	7.24
10000	991	5.72	1043	6.24	1092	6.77	1138	7.30	-----	-----
10500	1009	6.28	1060	6.83	1109	7.37	1155	7.93	-----	-----
11000	1026	6.89	1077	7.46	1125	8.03	1171	8.60	-----	-----
11500	1044	7.54	1095	8.13	1142	8.72	-----	-----	-----	-----
12000	1062	8.23	1112	8.85	-----	-----	-----	-----	-----	-----
12500	-----	-----	-----	-----	-----	-----	-----	-----	-----	-----

Std Static Motor and Drive – 717–911 RPM, Max BHP 4.9 Medium Static Motor and Drive – 913–1116 RPM, Max BHP 6.5
High Static Motor and Drive – 941–1176 RPM, Max BHP 8.7 ----- Outside operating range
Boldface – Field-supplied Drive

FAN PERFORMANCE (cont.)

TABLE 16 – RAH183, 15 TON HORIZONTAL SUPPLY / RETURN

CFM	Available External Static Pressure (in. wg)									
	0.2		0.4		0.6		0.8		1.0	
	RPM	BHP	RPM	BHP	RPM	BHP	RPM	BHP	RPM	BHP
4500	451	0.84	533	1.21	605	1.63	668	2.12	726	2.67
4900	476	1.01	554	1.40	623	1.84	685	2.34	742	2.89
5250	498	1.18	573	1.60	640	2.05	701	2.55	756	3.11
5600	520	1.37	593	1.82	658	2.28	717	2.79	771	3.35
6000	546	1.61	616	2.10	679	2.58	736	3.10	789	3.67
6400	572	1.88	640	2.41	700	2.91	756	3.45	808	4.03
6750	595	2.13	661	2.70	720	3.23	774	3.79	825	4.38
7100	619	2.41	683	3.02	740	3.59	793	4.16	842	4.76
7500	646	2.75	708	3.42	764	4.02	815	4.62	-----	-----

CFM	Available External Static Pressure (in. wg)									
	1.2		1.4		1.6		1.8		2.0	
	RPM	BHP	RPM	BHP	RPM	BHP	RPM	BHP	RPM	BHP
4500	778	3.25	826	3.86	871	4.49	913	5.15	-----	-----
4900	794	3.49	842	4.12	887	4.78	-----	-----	-----	-----
5250	808	3.72	856	4.36	-----	-----	-----	-----	-----	-----
5600	822	3.97	870	4.62	-----	-----	-----	-----	-----	-----
6000	839	4.29	-----	-----	-----	-----	-----	-----	-----	-----
6400	857	4.65	-----	-----	-----	-----	-----	-----	-----	-----
6750	-----	-----	-----	-----	-----	-----	-----	-----	-----	-----
7100	-----	-----	-----	-----	-----	-----	-----	-----	-----	-----
7500	-----	-----	-----	-----	-----	-----	-----	-----	-----	-----

Std Static Motor and Drive – 514–680 RPM, Max BHP 2.2 Medium Static Motor and Drive – 614–780 RPM, Max BHP 3.3
 High Static Motor and Drive – 746–912 RPM, Max BHP 4.9 ----- Outside operating range
Boldface – Field-supplied Drive

TABLE 17 – RAH213, 17.5 TON HORIZONTAL SUPPLY / RETURN

CFM	Available External Static Pressure (in. wg)									
	0.2		0.4		0.6		0.8		1.0	
	RPM	BHP	RPM	BHP	RPM	BHP	RPM	BHP	RPM	BHP
5250	498	1.18	573	1.60	640	2.05	701	2.55	756	3.11
5700	526	1.43	599	1.89	663	2.35	721	2.86	776	3.43
6100	552	1.67	622	2.17	684	2.66	741	3.18	794	3.76
6500	579	1.95	646	2.49	706	3.00	761	3.54	813	4.12
7000	612	2.33	677	2.93	734	3.48	788	4.05	837	4.64
7500	646	2.75	708	3.42	764	4.02	815	4.62	863	5.23
7900	673	3.13	734	3.86	788	4.50	838	5.12	884	5.75
8300	700	3.53	760	4.33	812	5.01	861	5.66	906	6.32
8750	731	4.03	789	4.90	840	5.63	887	6.33	-----	-----

CFM	Available External Static Pressure (in. wg)									
	1.2		1.4		1.6		1.8		2.0	
	RPM	BHP	RPM	BHP	RPM	BHP	RPM	BHP	RPM	BHP
5250	808	3.72	856	4.36	901	5.04	943	5.75	983	6.48
5700	826	4.05	874	4.71	918	5.40	960	6.13	-----	-----
6100	843	4.38	890	5.05	934	5.75	976	6.50	-----	-----
6500	861	4.75	907	5.43	951	6.14	-----	-----	-----	-----
7000	885	5.28	929	5.96	-----	-----	-----	-----	-----	-----
7500	909	5.88	-----	-----	-----	-----	-----	-----	-----	-----
7900	929	6.42	-----	-----	-----	-----	-----	-----	-----	-----
8300	-----	-----	-----	-----	-----	-----	-----	-----	-----	-----
8750	-----	-----	-----	-----	-----	-----	-----	-----	-----	-----

Std Static Motor and Drive – 622–822 RPM, Max BHP 3.3 Medium Static Motor and Drive – 713–879 RPM, Max BHP 4.9
 High Static Motor and Drive – 882–1078 RPM, Max BHP 6.5 ----- Outside operating range
Boldface – Field-supplied Drive

FAN PERFORMANCE (cont.)

TABLE 18 – RAH243, 20 TON HORIZONTAL SUPPLY / RETURN

CFM	Available External Static Pressure (in. wg)									
	0.2		0.4		0.6		0.8		1.0	
	RPM	BHP	RPM	BHP	RPM	BHP	RPM	BHP	RPM	BHP
6000	546	1.57	617	2.10	680	2.67	738	3.29	790	3.93
6500	579	1.90	646	2.46	707	3.07	763	3.71	814	4.39
7000	613	2.28	677	2.87	735	3.51	789	4.19	839	4.89
7500	648	2.71	708	3.34	764	4.01	816	4.72	865	5.46
8000	683	3.20	740	3.86	794	4.57	846	5.30	892	6.08
8500	718	3.76	773	4.45	825	5.18	873	5.95	919	6.75
9000	754	4.37	814	5.10	856	5.87	903	6.67	947	7.50
9500	-----	-----	840	5.82	887	6.51	933	7.45	976	8.31
10000	-----	-----	874	6.50	920	7.44	965	8.30	-----	-----

CFM	Available External Static Pressure (in. wg)									
	1.2		1.4		1.6		1.8		2.0	
	RPM	BHP	RPM	BHP	RPM	BHP	RPM	BHP	RPM	BHP
6000	839	4.60	885	5.29	928	6.01	969	6.75	1008	7.51
6500	862	5.09	907	5.82	950	6.57	990	7.34	1028	8.13
7000	886	5.63	930	6.39	972	7.17	1012	7.97	1050	8.70
7500	911	6.22	954	7.01	995	7.83	1035	8.66	-----	-----
8000	936	6.87	979	7.69	1019	8.54	-----	-----	-----	-----
8500	965	7.58	1004	8.44	-----	-----	-----	-----	-----	-----
9000	990	8.36	-----	-----	-----	-----	-----	-----	-----	-----
9500	-----	-----	-----	-----	-----	-----	-----	-----	-----	-----
10000	-----	-----	-----	-----	-----	-----	-----	-----	-----	-----

Std Static Motor and Drive – 690–863 RPM, Max BHP 4.9 Medium Static Motor and Drive – 835–1021 RPM, Max BHP 6.5
 High Static Motor and Drive – 941–1176 RPM, Max BHP 8.7 ----- Outside operating range
Boldface – Field-supplied Drive

TABLE 19 – RAH303, 25 TON HORIZONTAL SUPPLY / RETURN

CFM	Available External Static Pressure (in. wg)									
	0.2		0.4		0.6		0.8		1.0	
	RPM	BHP	RPM	BHP	RPM	BHP	RPM	BHP	RPM	BHP
7500	553	1.92	621	2.46	683	3.07	741	3.72	795	4.42
8000	575	2.21	639	2.77	700	3.39	756	4.07	809	4.78
8500	596	2.52	658	3.10	716	3.73	771	4.43	823	5.16
9000	616	2.86	675	3.44	732	4.10	786	4.80	836	5.55
9500	636	3.22	693	3.82	747	4.48	800	5.20	849	5.97
10000	656	3.60	710	4.21	763	4.89	813	5.62	862	6.40
10500	675	4.02	727	4.64	778	5.32	827	6.07	874	6.86
11000	694	4.46	744	5.09	793	5.79	841	6.50	887	7.34
11500	713	4.93	761	5.57	808	6.27	854	7.03	899	7.84

CFM	Available External Static Pressure (in. wg)									
	1.2		1.4		1.6		1.8		2.0	
	RPM	BHP	RPM	BHP	RPM	BHP	RPM	BHP	RPM	BHP
7500	845	5.14	892	5.90	936	6.68	978	7.48	1018	8.31
8000	859	5.53	905	6.31	949	7.11	991	7.94	-----	-----
8500	872	5.93	918	6.73	961	7.56	1003	8.41	-----	-----
9000	884	6.34	930	7.16	973	8.01	-----	-----	-----	-----
9500	896	6.77	941	7.61	984	8.48	-----	-----	-----	-----
10000	908	7.22	953	8.08	-----	-----	-----	-----	-----	-----
10500	920	7.69	963	8.56	-----	-----	-----	-----	-----	-----
11000	931	8.18	-----	-----	-----	-----	-----	-----	-----	-----
11500	943	8.70	-----	-----	-----	-----	-----	-----	-----	-----

Std Static Motor and Drive – 647–791 RPM, Max BHP 4.9 Medium Static Motor and Drive – 755–923 RPM, Max BHP 6.5
 High Static Motor and Drive – 827–1010 RPM, Max BHP 8.7 ----- Outside operating range
Boldface – Field-supplied Drive

FAN PERFORMANCE (cont.)

TABLE 20 – PULLEY ADJUSTMENT

Unit RAH	Motor/Drive Combo	MOTOR PULLEY TURNS OPEN										
		0	0.5	1	1.5	2	2.5	3	3.5	4	4.5	5
181 – 183	Standard Static	680	663	647	630	614	597	580	564	547	531	514
	Medium Static	863	845	826	808	789	771	753	734	716	697	679
	High Static	1009	991	972	954	936	918	899	881	863	844	826
210 – 213	Standard Static	822	802	782	762	742	722	702	682	662	642	622
	Medium Static	879	862	846	829	813	796	779	763	746	730	713
	High Static	1078	1058	1039	1019	1000	980	960	941	921	902	882
240 – 243	Standard Static	863	846	828	811	794	777	759	742	725	707	690
	Medium Static	1021	1002	984	965	947	928	909	891	872	854	835
	High Static	1176	1153	1129	1106	1082	1059	1035	1012	988	965	941
300 – 303	Standard Static	911	892	872	853	833	814	795	775	756	736	717
	Medium Static	1116	1096	1075	1055	1035	1015	994	974	954	933	913
	High Static	1176	1153	1129	1106	1082	1059	1035	1012	988	965	941

NOTE: Do not adjust pulley further than 5 turns open.

■ – Factory settings

ELECTRICAL DATA FOR UNITS PRODUCED ON OR AFTER JULY 30, 2012

NOTE: Check the serial number of unit to verify production date.

SERIAL NUMBER

1	2	3	4	5	6	7	8	9	10
U	1	2	3	1	1	2	3	4	5

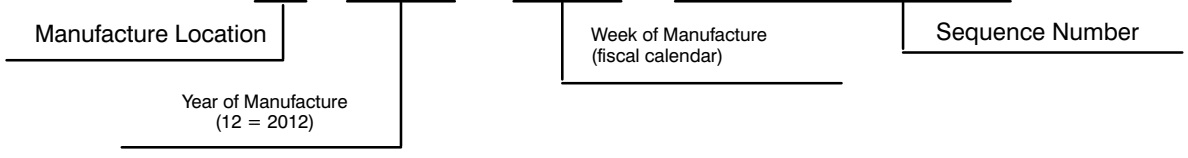

ELECTRICAL INFORMATION (UNITS PRODUCED ON OR AFTER JULY 30, 2012) cont.

TABLE 21 – 2-STAGE COOLING WITH SINGLE SPEED INDOOR FAN MOTOR

UNIT RAH	V-Ph-Hz	VOLTAGE RANGE		COMP 1		COMP 2		OFM (ea)		IFM		
		MIN	MAX	RLA	LRA	RLA	LRA	WATTS	FLA	TYPE	EFF at Full Load	FLA
181/183	208-3-60	187	253	25.0	164	25.0	164	350	1.5	STD	88.6%	8.4
										MED	87.0%	10.6
										HIGH	82.9%	13.6
	230-3-60	187	253	25.0	164	25.0	164	350	1.5	STD	88.6%	8.3
										MED	87.0%	10.6
										HIGH	82.9%	12.7
	460-3-60	414	506	12.8	100	12.8	100	277	0.9	STD	88.6%	4.2
										MED	87.0%	5.3
										HIGH	82.9%	6.4
	575-3-60	518	633	9.6	78	9.6	78	397	0.6	STD	81.1%	2.8
										MED	81.1%	2.8
										HIGH	83.6%	5.6
210/213	208-3-60	187	253	27.6	191	25.0	164	350	1.5	STD	87.0%	10.6
										MED	82.9%	13.6
										HIGH	89.5%	17.1
	230-3-60	187	253	27.6	191	25.0	164	350	1.5	STD	87.0%	10.6
										MED	82.9%	12.7
										HIGH	89.5%	17.1
	460-3-60	414	506	12.8	100	12.2	100	277	0.9	STD	87.0%	5.3
										MED	82.9%	6.4
										HIGH	89.5%	8.6
	575-3-60	518	633	9.6	78	9.0	78	397	0.6	STD	81.1%	2.8
										MED	83.6%	5.6
										HIGH	89.5%	7.6
240/243	208-3-60	187	253	30.1	225	30.1	225	350	1.5	STD	82.9%	13.6
										MED	89.5%	17.1
										HIGH	91.7%	28.5
	230-3-60	187	253	30.1	225	30.1	225	350	1.5	STD	82.9%	12.7
										MED	89.5%	17.1
										HIGH	91.7%	28.5
	460-3-60	414	506	16.7	114	16.7	114	277	0.9	STD	82.9%	6.4
										MED	89.5%	8.6
										HIGH	91.7%	14.3
	575-3-60	518	633	12.2	80	12.2	80	397	0.6	STD	83.6%	5.6
										MED	89.5%	7.6
										HIGH	91.7%	9.5
300/303	208-3-60	187	253	48.1	245	33.3	239	350	1.5	STD	82.9%	13.6
										MED	89.5%	17.1
										HIGH	91.7%	28.5
	230-3-60	187	253	48.1	245	33.3	239	350	1.5	STD	82.9%	12.7
										MED	89.5%	17.1
										HIGH	91.7%	28.5
	460-3-60	414	506	18.6	125	17.9	125	277	0.9	STD	82.9%	6.4
										MED	89.5%	8.6
										HIGH	91.7%	14.3
	575-3-60	518	633	14.7	100	12.8	80	397	0.6	STD	83.6%	5.6
										MED	89.5%	7.6
										HIGH	91.7%	9.5

ELECTRICAL INFORMATION

(UNITS PRODUCED ON OR AFTER JULY 30, 2012) cont.

TABLE 22 – 2-STAGE COOLING WITH 2-SPEED INDOOR FAN MOTOR

UNIT RAH	V-Ph-Hz	VOLTAGE RANGE		COMP 1		COMP 2		OFM (ea)		IFM		
		MIN	MAX	RLA	LRA	RLA	LRA	WATTS	FLA	TYPE	EFF at Full Load	FLA
181/183	208-3-60	187	253	25.0	164	25.0	164	350	1.5	STD	85.0%	8.6
										MED	81.5%	10.8
										HIGH	83.6%	13.6
	230-3-60	187	253	25.0	164	25.0	164	350	1.5	STD	85.0%	7.8
										MED	81.5%	9.8
										HIGH	83.6%	12.7
	460-3-60	414	506	12.8	100	12.8	100	277	0.9	STD	85.0%	3.8
										MED	81.5%	4.9
										HIGH	83.6%	6.4
	575-3-60	518	633	9.6	78	9.6	78	397	0.6	STD	81.1%	4.5
										MED	81.1%	4.5
										HIGH	83.6%	6.2
210/213	208-3-60	187	253	27.6	191	25.0	164	350	1.5	STD	81.5%	10.8
										MED	83.6%	13.6
										HIGH	89.5%	17.1
	230-3-60	187	253	27.6	191	25.0	164	350	1.5	STD	81.5%	9.8
										MED	83.6%	12.7
										HIGH	89.5%	17.1
	460-3-60	414	506	12.8	100	12.2	100	277	0.9	STD	81.5%	4.9
										MED	83.6%	6.4
										HIGH	89.5%	8.6
	575-3-60	518	633	9.6	78	9.0	78	397	0.6	STD	81.1%	4.5
										MED	83.6%	6.2
										HIGH	89.5%	7.6
240/243	208-3-60	187	253	30.1	225	30.1	225	350	1.5	STD	83.6%	13.6
										MED	89.5%	17.1
										HIGH	91.7%	28.5
	230-3-60	187	253	30.1	225	30.1	225	350	1.5	STD	83.6%	12.7
										MED	89.5%	17.1
										HIGH	91.7%	28.5
	460-3-60	414	506	16.7	114	16.7	114	277	0.9	STD	83.6%	6.4
										MED	89.5%	8.6
										HIGH	91.7%	14.3
	575-3-60	518	633	12.2	80	12.2	80	397	0.6	STD	83.6%	6.2
										MED	89.5%	7.6
										HIGH	91.7%	9.5
300/303	208-3-60	187	253	48.1	245	33.3	239	350	1.5	STD	83.6%	13.6
										MED	89.5%	17.1
										HIGH	91.7%	28.5
	230-3-60	187	253	48.1	245	33.3	239	350	1.5	STD	83.6%	12.7
										MED	89.5%	17.1
										HIGH	91.7%	28.5
	460-3-60	414	506	18.6	125	17.9	125	277	0.9	STD	83.6%	6.4
										MED	89.5%	8.6
										HIGH	91.7%	14.3
	575-3-60	518	633	14.7	100	12.8	80	397	0.6	STD	83.6%	6.2
										MED	89.5%	7.6
										HIGH	91.7%	9.5

ELECTRICAL INFORMATION

(UNITS PRODUCED ON OR AFTER JULY 30, 2012) cont.

TABLE 23 – RAH181/183

ELECTRIC HEAT – ELECTRICAL DATA 2-STAGE COOLING SINGLE SPEED INDOOR FAN MOTOR

NOM. V–Ph–Hz	IFM TYPE	ELECTRIC HEATER PART NUMBER CRHEATER	NOM. PWR (kW)	APP PWR (kW)	SINGLE POINT KIT PART NUMBER CRSINGLE	
					NO C.O. or Unpowered C.O.	
					NO P.E.	w/ P.E. (pwrd fr/unit)
208/ 230–3–60	STD	279/270A00	25.0	18.8/23.0	–	–
		280/271A00	50.0	37.6/45.9	056	056
		281/272A00	75.0	56.3/68.9	056	056
	MED	279/270A00	25.0	18.8/23.0	–	–
		280/271A00	50.0	37.6/45.9	056	056
		281/272A00	75.0	56.3/68.9	056	056
	HIGH	279/270A00	25.0	18.8/23.0	–	–
		280/271A00	50.0	37.6/45.9	056	056
		281/272A00	75.0	56.3/68.9	056	056
460–3–60	STD	282/273A00	25.0	23.0	–	–
		283/274A00	50.0	45.9	–	057
		284/275A00	75.0	68.9	057	057
	MED	282/273A00	25.0	23.0	–	–
		283/274A00	50.0	45.9	057	057
		284/275A00	75.0	68.9	057	057
	HIGH	282/273A00	25.0	23.0	–	–
		283/274A00	50.0	45.9	057	057
		284/275A00	75.0	68.9	057	057
575–3–60	STD	285/276A00	24.8	22.8	–	–
		286/277A00	49.6	45.6	–	–
		287/278A00	74.4	68.3	057	057
	MED	285/276A00	24.8	22.8	–	–
		286/277A00	49.6	45.6	–	–
		287/278A00	74.4	68.3	057	057
	HIGH	285/276A00	24.8	22.8	–	–
		286/277A00	49.6	45.6	–	057
		287/278A00	74.4	68.3	057	057

ELECTRICAL INFORMATION

(UNITS PRODUCED ON OR AFTER JULY 30, 2012) cont.

TABLE 24 – RAH210/213

ELECTRIC HEAT – ELECTRICAL DATA 2-STAGE COOLING SINGLE SPEED INDOOR FAN MOTOR

NOM. V–Ph–Hz	IFM TYPE	ELECTRIC HEATER PART NUMBER CRHEATER	NOM. PWR (kW)	APP PWR (kW)	SINGLE POINT KIT PART NUMBER CRSINGLE	
					NO C.O. or Unpowered C.O.	
					NO P.E.	w/ P.E. (pwrd fr/unit)
208/ 230–3–60	STD	279/270A00	25.0	18.8/23.0	–	–
		280/271A00	50.0	37.6/45.9	056	056
		281/272A00	75.0	56.3/68.9	056	056
	MED	279/270A00	25.0	18.8/23.0	–	–
		280/271A00	50.0	37.6/45.9	056	056
		281/272A00	75.0	56.3/68.9	056	056
	HIGH	279/270A00	25.0	18.8/23.0	–	–
		280/271A00	50.0	37.6/45.9	056	056
		281/272A00	75.0	56.3/68.9	056	056
460–3–60	STD	282/273A00	25.0	23.0	–	–
		283/274A00	50.0	45.9	057	057
		284/275A00	75.0	68.9	057	057
	MED	282/273A00	25.0	23.0	–	–
		283/274A00	50.0	45.9	057	057
		284/275A00	75.0	68.9	057	057
	HIGH	282/273A00	25.0	23.0	–	–
		283/274A00	50.0	45.9	057	057
		284/275A00	75.0	68.9	057	057
575–3–60	STD	285/276A00	24.8	22.8	–	–
		286/277A00	49.6	45.6	–	–
		287/278A00	74.4	68.3	057	057
	MED	285/276A00	24.8	22.8	–	–
		286/277A00	49.6	45.6	–	057
		287/278A00	74.4	68.3	057	057
	HIGH	285/276A00	24.8	22.8	–	–
		286/277A00	49.6	45.6	–	057
		287/278A00	74.4	68.3	057	057

ELECTRICAL INFORMATION

(UNITS PRODUCED ON OR AFTER JULY 30, 2012) cont.

TABLE 25 – RAH240/243

ELECTRIC HEAT – ELECTRICAL DATA 2-STAGE COOLING SINGLE SPEED INDOOR FAN MOTOR

NOM. V–Ph–Hz	IFM TYPE	ELECTRIC HEATER PART NUMBER CRHEATER	NOM. PWR (kW)	APP PWR (kW)	SINGLE POINT KIT PART NUMBER CRSINGLE	
					NO C.O. or Unpowered C.O.	
					NO P.E.	w/ P.E. (pwrd fr/unit)
208/ 230–3–60	STD	279/270A00	25.0	18.8/23.0	–	–
		280/271A00	50.0	37.6/45.9	056	056
		281/272A00	75.0	56.3/68.9	056	056
	MED	279/270A00	25.0	18.8/23.0	–	–
		280/271A00	50.0	37.6/45.9	056	056
		281/272A00	75.0	56.3/68.9	056	056
	HIGH	279/270A00	25.0	18.8/23.0	–	056
		280/271A00	50.0	37.6/45.9	056	056
		281/272A00	75.0	56.3/68.9	056	056
460–3–60	STD	282/273A00	25.0	23.0	–	–
		283/274A00	50.0	45.9	057	057
		284/275A00	75.0	68.9	057	057
	MED	282/273A00	25.0	23.0	–	–
		283/274A00	50.0	45.9	057	057
		284/275A00	75.0	68.9	057	057
	HIGH	282/273A00	25.0	23.0	–	–
		283/274A00	50.0	45.9	057	057
		284/275A00	75.0	68.9	057	057
575–3–60	STD	285/276A00	24.8	22.8	–	–
		286/277A00	49.6	45.6	–	057
		287/278A00	74.4	68.3	057	057
	MED	285/276A00	24.8	22.8	–	–
		286/277A00	49.6	45.6	–	057
		287/278A00	74.4	68.3	057	057
	HIGH	285/276A00	24.8	22.8	–	–
		286/277A00	49.6	45.6	057	057
		287/278A00	74.4	68.3	057	057

ELECTRICAL INFORMATION

(UNITS PRODUCED ON OR AFTER JULY 30, 2012) cont.

TABLE 26 – RAH300/303

ELECTRIC HEAT – ELECTRICAL DATA 2-STAGE COOLING SINGLE SPEED INDOOR FAN MOTOR

NOM. V–Ph–Hz	IFM TYPE	ELECTRIC HEATER PART NUMBER CRHEATER	NOM. PWR (kW)	APP PWR (kW)	SINGLE POINT KIT PART NUMBER CRSINGLE	
					NO C.O. or Unpowered C.O.	
					NO P.E.	w/ P.E. (pwrd fr/unit)
208/ 230–3–60	STD	279/270A00	25.0	18.8/23.0	056	056
		280/271A00	50.0	37.6/45.9	056	056
		281/272A00	75.0	56.3/68.9	056	056
	MED	279/270A00	25.0	18.8/23.0	056	056
		280/271A00	50.0	37.6/45.9	056	056
		281/272A00	75.0	56.3/68.9	056	056
	HIGH	279/270A00	25.0	18.8/23.0	056	056
		280/271A00	50.0	37.6/45.9	056	056
		281/272A00	75.0	56.3/68.9	056	056
460–3–60	STD	282/273A00	25.0	23.0	–	–
		283/274A00	50.0	45.9	057	057
		284/275A00	75.0	68.9	057	057
	MED	282/273A00	25.0	23.0	–	–
		283/274A00	50.0	45.9	057	057
		284/275A00	75.0	68.9	057	057
	HIGH	282/273A00	25.0	23.0	–	057
		283/274A00	50.0	45.9	057	057
		284/275A00	75.0	68.9	057	057
575–3–60	STD	285/276A00	24.8	22.8	–	–
		286/277A00	49.6	45.6	–	057
		287/278A00	74.4	68.3	057	057
	MED	285/276A00	24.8	22.8	–	–
		286/277A00	49.6	45.6	–	057
		287/278A00	74.4	68.3	057	057
	HIGH	285/276A00	24.8	22.8	–	–
		286/277A00	49.6	45.6	057	057
		287/278A00	74.4	68.3	057	057

ELECTRICAL INFORMATION

(UNITS PRODUCED ON OR AFTER JULY 30, 2012) cont.

TABLE 27 – RAH181/183

ELECTRIC HEAT – ELECTRICAL DATA 2-STAGE COOLING 2-SPEED INDOOR FAN MOTOR

NOM. V–Ph–Hz	IFM TYPE	ELECTRIC HEATER PART NUMBER CRHEATER	NOM. PWR (kW)	APP PWR (kW)	SINGLE POINT KIT PART NUMBER CRSINGLE	
					NO C.O. or Unpowered C.O.	
					NO P.E.	w/ P.E. (pwrd fr/unit)
208/ 230–3–60	STD	279/270A00	25.0	18.8/23.0	–	–
		280/271A00	50.0	37.6/45.9	056	056
		281/272A00	75.0	56.3/68.9	056	056
	MED	279/270A00	25.0	18.8/23.0	–	–
		280/271A00	50.0	37.6/45.9	056	056
		281/272A00	75.0	56.3/68.9	056	056
	HIGH	279/270A00	25.0	18.8/23.0	–	–
		280/271A00	50.0	37.6/45.9	056	056
		281/272A00	75.0	56.3/68.9	056	056
460–3–60	STD	282/273A00	25.0	23.0	–	–
		283/274A00	50.0	45.9	–	057
		284/275A00	75.0	68.9	057	057
	MED	282/273A00	25.0	23.0	–	–
		283/274A00	50.0	45.9	057	057
		284/275A00	75.0	68.9	057	057
	HIGH	282/273A00	25.0	23.0	–	–
		283/274A00	50.0	45.9	057	057
		284/275A00	75.0	68.9	057	057
575–3–60	STD	285/276A00	24.8	22.8	–	–
		286/277A00	49.6	45.6	–	057
		287/278A00	74.4	68.3	057	057
	MED	285/276A00	24.8	22.8	–	–
		286/277A00	49.6	45.6	–	057
		287/278A00	74.4	68.3	057	057
	HIGH	285/276A00	24.8	22.8	–	–
		286/277A00	49.6	45.6	–	057
		287/278A00	74.4	68.3	057	057

ELECTRICAL INFORMATION

(UNITS PRODUCED ON OR AFTER JULY 30, 2012) cont.

TABLE 28 – RAH210/213

ELECTRIC HEAT – ELECTRICAL DATA 2-STAGE COOLING 2-SPEED INDOOR FAN MOTOR

NOM. V–Ph–Hz	IFM TYPE	ELECTRIC HEATER PART NUMBER CRHEATER	NOM. PWR (kW)	APP PWR (kW)	SINGLE POINT KIT PART NUMBER CRSINGLE	
					NO C.O. or Unpowered C.O.	
					NO P.E.	w/ P.E. (pwrd fr/unit)
208/ 230–3–60	STD	279/270A00	25.0	18.8/23.0	–	–
		280/271A00	50.0	37.6/45.9	056	056
		281/272A00	75.0	56.3/68.9	056	056
	MED	279/270A00	25.0	18.8/23.0	–	–
		280/271A00	50.0	37.6/45.9	056	056
		281/272A00	75.0	56.3/68.9	056	056
	HIGH	279/270A00	25.0	18.8/23.0	–	–
		280/271A00	50.0	37.6/45.9	056	056
		281/272A00	75.0	56.3/68.9	056	056
460–3–60	STD	282/273A00	25.0	23.0	–	–
		283/274A00	50.0	45.9	057	057
		284/275A00	75.0	68.9	057	057
	MED	282/273A00	25.0	23.0	–	–
		283/274A00	50.0	45.9	057	057
		284/275A00	75.0	68.9	057	057
	HIGH	282/273A00	25.0	23.0	–	–
		283/274A00	50.0	45.9	057	057
		284/275A00	75.0	68.9	057	057
575–3–60	STD	285/276A00	24.8	22.8	–	–
		286/277A00	49.6	45.6	–	057
		287/278A00	74.4	68.3	057	057
	MED	285/276A00	24.8	22.8	–	–
		286/277A00	49.6	45.6	–	057
		287/278A00	74.4	68.3	057	057
	HIGH	285/276A00	24.8	22.8	–	–
		286/277A00	49.6	45.6	–	057
		287/278A00	74.4	68.3	057	057

ELECTRICAL INFORMATION

(UNITS PRODUCED ON OR AFTER JULY 30, 2012) cont.

TABLE 29 – RAH240/243

ELECTRIC HEAT – ELECTRICAL DATA 2-STAGE COOLING 2-SPEED INDOOR FAN MOTOR

NOM. V–Ph–Hz	IFM TYPE	ELECTRIC HEATER PART NUMBER CRHEATER	NOM. PWR (kW)	APP PWR (kW)	SINGLE POINT KIT PART NUMBER CRSINGLE	
					NO C.O. or Unpowered C.O.	
					NO P.E.	w/ P.E. (pwrd fr/unit)
208/ 230–3–60	STD	279/270A00	25.0	18.8/23.0	–	–
		280/271A00	50.0	37.6/45.9	056	056
		281/272A00	75.0	56.3/68.9	056	056
	MED	279/270A00	25.0	18.8/23.0	–	–
		280/271A00	50.0	37.6/45.9	056	056
		281/272A00	75.0	56.3/68.9	056	056
	HIGH	279/270A00	25.0	18.8/23.0	–	056
		280/271A00	50.0	37.6/45.9	056	056
		281/272A00	75.0	56.3/68.9	056	056
460–3–60	STD	282/273A00	25.0	23.0	–	–
		283/274A00	50.0	45.9	057	057
		284/275A00	75.0	68.9	057	057
	MED	282/273A00	25.0	23.0	–	–
		283/274A00	50.0	45.9	057	057
		284/275A00	75.0	68.9	057	057
	HIGH	282/273A00	25.0	23.0	–	–
		283/274A00	50.0	45.9	057	057
		284/275A00	75.0	68.9	057	057
575–3–60	STD	285/276A00	24.8	22.8	–	–
		286/277A00	49.6	45.6	–	057
		287/278A00	74.4	68.3	057	057
	MED	285/276A00	24.8	22.8	–	–
		286/277A00	49.6	45.6	–	057
		287/278A00	74.4	68.3	057	057
	HIGH	285/276A00	24.8	22.8	–	–
		286/277A00	49.6	45.6	057	057
		287/278A00	74.4	68.3	057	057

ELECTRICAL INFORMATION

(UNITS PRODUCED ON OR AFTER JULY 30, 2012) cont.

TABLE 30 – RAH300/303

ELECTRIC HEAT – ELECTRICAL DATA 2-STAGE COOLING 2-SPEED INDOOR FAN MOTOR

NOM. V–Ph–Hz	IFM TYPE	ELECTRIC HEATER PART NUMBER CRHEATER	NOM. PWR (kW)	APP PWR (kW)	SINGLE POINT KIT PART NUMBER CRSINGLE	
					NO C.O. or Unpowered C.O.	
					NO P.E.	w/ P.E. (pwrd fr/unit)
208/ 230–3–60	STD	279/270A00	25.0	18.8/23.0	056	056
		280/271A00	50.0	37.6/45.9	056	056
		281/272A00	75.0	56.3/68.9	056	056
	MED	279/270A00	25.0	18.8/23.0	056	056
		280/271A00	50.0	37.6/45.9	056	056
		281/272A00	75.0	56.3/68.9	056	056
	HIGH	279/270A00	25.0	18.8/23.0	056	056
		280/271A00	50.0	37.6/45.9	056	056
		281/272A00	75.0	56.3/68.9	056	056
460–3–60	STD	282/273A00	25.0	23.0	–	–
		283/274A00	50.0	45.9	057	057
		284/275A00	75.0	68.9	057	057
	MED	282/273A00	25.0	23.0	–	–
		283/274A00	50.0	45.9	057	057
		284/275A00	75.0	68.9	057	057
	HIGH	282/273A00	25.0	23.0	–	057
		283/274A00	50.0	45.9	057	057
		284/275A00	75.0	68.9	057	057
575–3–60	STD	285/276A00	24.8	22.8	–	–
		286/277A00	49.6	45.6	–	057
		287/278A00	74.4	68.3	057	057
	MED	285/276A00	24.8	22.8	–	–
		286/277A00	49.6	45.6	–	057
		287/278A00	74.4	68.3	057	057
	HIGH	285/276A00	24.8	22.8	–	–
		286/277A00	49.6	45.6	057	057
		287/278A00	74.4	68.3	057	057

ELECTRICAL INFORMATION (UNITS PRODUCED ON OR AFTER JULY 30, 2012) cont.

TABLE 31 – UNIT WIRE/FUSE SIZING DATA WITH SINGLE SPEED INDOOR FAN MOTOR

UNIT RAH	NO. M. V-Ph-Hz	IFM TYPE	ELEC. HTR			NO C.O. or UNPWR C.O.							
			CRHEATER***A00	Nom (kW)	FLA	NO RE.				w/ RE. (pwrd fr/unit)			
						MCA	MAX FUSE or HACR BRKR	DISC. SIZE		MCA	MAX FUSE or HACR BRKR	DISC. SIZE	
								FLA	LRA			FLA	LRA
181/183	208/230-3-60	STD	NONE	—	—	69.2/69.1	90/90	72/72	409	81.0/80.9	100/100	86/86	429
			279A00	18.8/25.0	52.1/60.1	75.6/85.5	90/90	72/79	409/409	90.4/100.3	100/110	86/92	429/429
			280A00	37.6/50.0	104.2/120.3	140.8/130.7	150/150	129/148	409/409	155.5/145.4	175/175	143/161	429/429
			281A00	56.3/75.0	156.4/180.4	166.9/190.8	200/200	190/217	409/409	181.7/205.5	200/225	203/231	429/429
		MED	NONE	—	—	71.4	90	75	423	83.2	100	88	443
			279A00	18.8/25.0	52.1/60.1	78.4/88.4	90/90	75/81	423/423	93.1/103.1	100/110	88/95	443/443
			280A00	37.6/50.0	104.2/120.3	143.5/133.6	150/150	132/151	423/423	158.3/148.3	175/175	146/164	443/443
			281A00	56.3/75.0	156.4/180.4	169.7/193.7	200/225	192/220	423/423	184.4/208.4	200/225	206/233	443/443
		HIGH	NONE	—	—	74.4/73.5	90/90	78/77	425	86.2/85.3	100/100	92/91	445
			279A00	18.8/25.0	52.1/60.1	82.1/91.0	90/100	78/84	425/425	96.9/105.8	100/110	92/97	445/445
			280A00	37.6/50.0	104.2/120.3	147.3/136.2	150/150	135/153	425/425	162.0/150.9	175/175	149/167	445/445
			281A00	56.3/75.0	156.4/180.4	173.4/196.3	200/225	196/222	425/425	188.2/211.0	200/225	209/236	445/445
	460-3-60	STD	NONE	—	—	35.7	45	37	242	41.9	50	45	254
			282A00	25.0	30.1	42.9	45	39	242	50.6	60	47	254
			283A00	50.0	60.1	65.4	70	74	242	73.1	80	81	254
			284A00	75.0	90.2	95.5	100	109	242	103.2	110	116	254
		MED	NONE	—	—	36.8	45	39	249	43.0	50	46	261
			282A00	25.0	30.1	44.3	45	41	249	52.0	60	48	261
			283A00	50.0	60.1	66.7	80	75	249	74.5	80	82	261
			284A00	75.0	90.2	96.8	100	110	249	104.6	110	117	261
		HIGH	NONE	—	—	37.9	50	40	250	44.1	50	47	262
			282A00	25.0	30.1	45.6	50	42	250	53.4	60	49	262
			283A00	50.0	60.1	68.1	80	76	250	75.9	80	84	262
			284A00	75.0	90.2	98.2	100	111	250	106.0	125	118	262
	575-3-60	STD	NONE	—	—	26.2	30	27	184	31.0	40	33	192
			285A00	24.8	23.9	33.4	35	31	184	39.4	40	36	192
			286A00	49.6	47.7	63.1	70	58	184	69.1	70	64	192
			287A00	74.4	71.6	75.1	80	86	184	81.1	90	91	192
MED		NONE	—	—	26.2	30	27	184	31.0	40	33	192	
		285A00	24.8	23.9	33.4	35	31	184	39.4	40	36	192	
		286A00	49.6	47.7	63.1	70	58	184	69.1	70	64	192	
		287A00	74.4	71.6	75.1	80	86	184	81.1	90	91	192	
HIGH		NONE	—	—	29.0	35	31	198	33.8	40	36	206	
		285A00	24.8	23.9	36.9	40	34	198	42.9	45	39	206	
		286A00	49.6	47.7	66.6	70	61	198	72.6	80	67	206	
		287A00	74.4	71.6	78.6	90	89	198	84.6	90	94	206	

ELECTRICAL INFORMATION (UNITS PRODUCED ON OR AFTER JULY 30, 2012) cont.

TABLE 31 – UNIT WIRE/FUSE SIZING DATA WITH SINGLE SPEED INDOOR FAN MOTOR (cont)

UNIT RAH	NO M. V-PH-HZ	IFM TYP E	ELEC. HTR			NO C.O. or UNPWR C.O.							
			CRHEATER***A00	Nom (kW)	FLA	NO P.E.				w/ P.E. (pwrd fr/unit)			
						MCA	MAX FUSE or HACR BRKR	DISC. SIZE		MCA	MAX FUSE or HACR BRKR	DISC. SIZE	
								FLA	LRA			FLA	LRA
210/213	208/230-3-60	STD	NONE	-	-	76.1	100	80	453	87.9	100	93	473
			279A00	18.8/25.0	52.1/60.1	78.4/88.4	100/100	80/81	453/453	93.1/103.1	100/110	93/95	473/473
			280A00	37.6/50.0	104.2/120.3	143.5/133.6	150/150	132/151	453/453	158.3/148.3	175/175	146/164	473/473
			281A00	56.3/75.0	156.4/180.4	169.7/193.7	200/225	192/220	453/453	184.4/208.4	200/225	206/233	473/473
		MED	NONE	-	-	79.1/78.2	100/100	83/82	455	90.9/90.0	100/100	97/96	475
			279A00	18.8/25.0	52.1/60.1	82.1/91.0	100/100	83/84	455/455	96.9/105.8	100/110	97/97	475/475
			280A00	37.6/50.0	104.2/120.3	147.3/136.2	150/150	135/153	455/455	162.0/150.9	175/175	149/167	475/475
			281A00	56.3/75.0	156.4/180.4	173.4/196.3	200/225	196/222	455/455	188.2/211.0	200/225	209/236	475/475
		HIGH	NONE	-	-	82.6	100	87	451	94.4	110	101	471
			279A00	18.8/25.0	52.1/60.1	86.5/96.5	100/100	87/89	451/451	101.3/111.3	110/125	101/102	471/471
			280A00	37.6/50.0	104.2/120.3	151.6/141.7	175/175	139/158	451/451	166.4/156.4	175/175	153/172	471/471
			281A00	56.3/75.0	156.4/180.4	177.8/201.8	200/225	200/227	451/451	192.5/216.5	200/250	213/241	471/471
	460-3-60	STD	NONE	-	-	37.1	45	39	251	43.3	50	46	263
			282A00	25.0	30.1	44.3	45	41	251	52.0	60	48	263
			283A00	50.0	60.1	66.7	80	75	251	74.5	80	82	263
			284A00	75.0	90.2	96.8	100	110	251	104.6	110	117	263
		MED	NONE	-	-	38.2	50	40	252	44.4	50	47	264
			282A00	25.0	30.1	45.6	50	42	252	53.4	60	49	264
			283A00	50.0	60.1	68.1	80	76	252	75.9	80	84	264
			284A00	75.0	90.2	98.2	100	111	252	106.0	125	118	264
		HIGH	NONE	-	-	40.4	50	43	250	46.6	50	50	262
			282A00	25.0	30.1	48.4	50	45	250	56.1	60	52	262
			283A00	50.0	60.1	70.9	80	79	250	78.6	80	86	262
			284A00	75.0	90.2	101.0	110	114	250	108.7	125	121	262
575-3-60	STD	NONE	-	-	26.2	30	27	186	31.0	40	33	194	
		285A00	24.8	23.9	33.4	35	31	186	39.4	40	36	194	
		286A00	49.6	47.7	63.1	70	58	186	69.1	70	64	194	
		287A00	74.4	71.6	75.1	80	86	186	81.1	90	91	194	
	MED	NONE	-	-	29.0	35	31	200	33.8	40	36	208	
		285A00	24.8	23.9	36.9	40	34	200	42.9	45	39	208	
		286A00	49.6	47.7	66.6	70	61	200	72.6	80	67	208	
		287A00	74.4	71.6	78.6	90	89	200	84.6	90	94	208	
	HIGH	NONE	-	-	31.0	40	33	198	35.8	45	38	206	
		285A00	24.8	23.9	39.4	40	36	198	45.4	50	42	206	
		286A00	49.6	47.7	69.1	70	64	198	75.1	80	69	206	
		287A00	74.4	71.6	81.1	90	91	198	87.1	90	97	206	

ELECTRICAL INFORMATION (UNITS PRODUCED ON OR AFTER JULY 30, 2012) cont.

TABLE 31 – UNIT WIRE/FUSE SIZING DATA WITH SINGLE SPEED INDOOR FAN MOTOR (cont)

UNIT RAH	NO M. V. – Ph–HZ	IFM TYPE	ELEC. HTR			NO C.O. or UNPWR C.O.							
			CRHEATER***A00	Nom (kW)	FLA	NO PE.				w/ PE. (pwrd fr/unit)			
						MCA	MAX FUSE or HACR BRKR	DISC. SIZE		MCA	MAX FUSE or HACR BRKR	DISC. SIZE	
								FLA	LRA			FLA	LRA
240/243	208/230–3–60	STD	NONE	–	–	87.3/86.4	100/100	92/91	550	99.1/98.2	125/125	105/104	570
			279A00	18.8/25.0	52.1/60.1	87.3/91.0	100/100	92/91	550/550	99.1/105.8	125/125	105/104	570/570
			280A00	37.6/50.0	104.2/120.3	147.3/136.2	150/150	135/153	550/550	162.0/150.9	175/175	149/167	570/570
			281A00	56.3/75.0	156.4/180.4	173.4/196.3	200/225	196/222	550/550	188.2/211.0	200/225	209/236	570/570
		MED	NONE	–	–	90.8	100	96	546	102.6	125	109	566
			279A00	18.8/25.0	52.1/60.1	90.8/96.5	100/100	96/96	546/546	102.6/111.3	125/125	109/109	566/566
			280A00	37.6/50.0	104.2/120.3	151.6/141.7	175/175	139/158	546/546	166.4/156.4	175/175	153/172	566/566
		HIGH	281A00	56.3/75.0	156.4/180.4	177.8/201.8	200/225	200/227	546/546	192.5/216.5	200/250	213/241	566/566
			NONE	–	–	102.2	125	109	625	114.0	125	122	645
	279A00		18.8/25.0	52.1/60.1	102.2/110.8	125/125	109/109	625/625	115.5/125.5	125/150	122/122	645/645	
	280A00	37.6/50.0	104.2/120.3	165.9/155.9	175/175	153/171	625/625	180.6/170.7	200/175	166/185	645/645		
		281A00	56.3/75.0	156.4/180.4	192.0/216.0	200/250	213/240	625/625	206.8/230.8	225/250	226/254	645/645	
		NONE	–	–	47.6	60	50	280	53.8	60	57	292	
	460–3–60	STD	282A00	25.0	30.1	47.6	60	50	280	53.8	60	57	292
			283A00	50.0	60.1	68.1	80	76	280	75.9	80	84	292
			284A00	75.0	90.2	98.2	100	111	280	106.0	125	118	292
			NONE	–	–	49.8	60	52	278	56.0	70	60	290
		MED	282A00	25.0	30.1	49.8	60	52	278	56.1	70	60	290
			283A00	50.0	60.1	70.9	80	79	278	78.6	80	86	290
			284A00	75.0	90.2	101.0	110	114	278	108.7	125	121	290
		HIGH	NONE	–	–	55.5	60	59	318	61.7	70	66	330
			282A00	25.0	30.1	55.5	60	59	318	63.3	70	66	330
			283A00	50.0	60.1	78.0	90	86	318	85.7	90	93	330
		284A00	75.0	90.2	108.1	125	120	318	115.8	125	127	330	
575–3–60		STD	NONE	–	–	35.5	45	37	204	40.3	50	43	212
	285A00		24.8	23.9	36.9	45	37	204	42.9	50	43	212	
	286A00		49.6	47.7	66.6	70	61	204	72.6	80	67	212	
	287A00		74.4	71.6	78.6	90	89	204	84.6	90	94	212	
	MED	NONE	–	–	37.5	45	40	202	42.3	50	45	210	
		285A00	24.8	23.9	39.4	45	40	202	45.4	50	45	210	
		286A00	49.6	47.7	69.1	70	64	202	75.1	80	69	210	
	287A00	74.4	71.6	81.1	90	91	202	87.1	90	97	210		
	HIGH	NONE	–	–	39.4	50	42	229	44.2	50	47	237	
		285A00	24.8	23.9	41.8	50	42	229	47.8	50	47	237	
		286A00	49.6	47.7	71.5	80	66	229	77.5	80	71	237	
	287A00	74.4	71.6	83.5	90	93	229	89.5	100	99	237		

ELECTRICAL INFORMATION (UNITS PRODUCED ON OR AFTER JULY 30, 2012) cont.

TABLE 31 – UNIT WIRE/FUSE SIZING DATA WITH SINGLE SPEED INDOOR FAN MOTOR (cont)

UNIT RAH	NOM. V-Ph-HZ	IFM TYP E	ELEC. HTR			NO C.O. or UNPWR C.O.							
			CRHEATER***A00	Nom (kW)	FLA	NO P.E.				w/ P.E. (pwrd fr/unit)			
						MCA	MAX FUSE or HACR BRKR	DISC. SIZE		MCA	MAX FUSE or HACR BRKR	DISC. SIZE	
								FLA	LRA			FLA	LRA
300/303	208/230-3-60	STD	NONE	-	-	116.0/115.1	150/150	120/119	590	127.8/126.9	175/175	133/132	610
			279A00	18.8/25.0	52.1/60.1	116.0/115.1	150/150	120/119	590/590	127.8/126.9	175/175	133/132	610/610
			280A00	37.6/50.0	104.2/120.3	147.3/136.2	150/150	135/153	590/590	162.0/150.9	175/175	149/167	610/610
			281A00	56.3/75.0	156.4/180.4	173.4/196.3	200/225	196/222	590/590	188.2/211.0	200/225	209/236	610/610
		MED	NONE	-	-	119.5	150	124	586	131.3	175	137	606
			279A00	18.8/25.0	52.1/60.1	119.5/119.5	150/150	124/124	586/586	131.3/131.3	175/175	137/137	606/606
			280A00	37.6/50.0	104.2/120.3	151.6/141.7	175/175	139/158	586/586	166.4/156.4	175/175	153/172	606/606
			281A00	56.3/75.0	156.4/180.4	177.8/201.8	200/225	200/227	586/586	192.5/216.5	200/250	213/241	606/606
		HIGH	NONE	-	-	130.9	175	137	665	142.7	175	150	685
			279A00	18.8/25.0	52.1/60.1	130.9/130.9	175/175	137/137	665/665	142.7/142.7	175/175	150/150	685/685
			280A00	37.6/50.0	104.2/120.3	165.9/155.9	175/175	153/171	665/665	180.6/170.7	200/175	166/185	685/685
			281A00	56.3/75.0	156.4/180.4	192.0/216.0	200/250	213/240	665/665	206.8/230.8	225/250	226/254	685/685
	460-3-60	STD	NONE	-	-	53.0	60	56	306	59.2	70	63	318
			282A00	25.0	30.1	53.0	60	56	306	59.2	70	63	318
			283A00	50.0	60.1	68.1	80	76	306	75.9	80	84	318
			284A00	75.0	90.2	98.2	100	111	306	106.0	125	118	318
		MED	NONE	-	-	55.2	60	58	304	61.4	70	65	316
			282A00	25.0	30.1	55.2	60	58	304	61.4	70	65	316
			283A00	50.0	60.1	70.9	80	79	304	78.6	80	86	316
			284A00	75.0	90.2	101.0	110	114	304	108.7	125	121	316
		HIGH	NONE	-	-	60.9	70	65	344	67.1	80	72	356
			282A00	25.0	30.1	60.9	70	65	344	67.1	80	72	356
			283A00	50.0	60.1	78.0	90	86	344	85.7	90	93	356
			284A00	75.0	90.2	108.1	125	120	344	115.8	125	127	356
575-3-60	STD	NONE	-	-	40.4	50	42	228	45.2	50	48	236	
		285A00	24.8	23.9	40.4	50	42	228	45.2	50	48	236	
		286A00	49.6	47.7	66.6	70	61	228	72.6	80	67	236	
		287A00	74.4	71.6	78.6	90	89	228	84.6	90	94	236	
	MED	NONE	-	-	42.4	50	45	226	47.2	60	50	234	
		285A00	24.8	23.9	42.4	50	45	226	47.2	60	50	234	
		286A00	49.6	47.7	69.1	70	64	226	75.1	80	69	234	
		287A00	74.4	71.6	81.1	90	91	226	87.1	90	97	234	
	HIGH	NONE	-	-	44.3	50	47	253	49.1	60	52	261	
		285A00	24.8	23.9	44.3	50	47	253	49.1	60	52	261	
		286A00	49.6	47.7	71.5	80	66	253	77.5	80	71	261	
		287A00	74.4	71.6	83.5	90	93	253	89.5	100	99	261	

ELECTRICAL INFORMATION (UNITS PRODUCED ON OR AFTER JULY 30, 2012) cont.

TABLE 32 – UNIT WIRE SIZING DATA WITH FACTORY INSTALLED 2 SPEED INDOOR FAN OPTION

UNIT RAH	NO M. V. PH-HZ	IFM TYPE	ELEC. HTR			NO C.O. or UNPWR C.O.							
			CRHEATER***A00	Nom (kW)	FLA	NO P.E.				w/ P.E. (pwrd fr/unit)			
						MCA	MAX FUSE or HACR BRKR	DISC. SIZE		MCA	MAX FUSE or HACR BRKR	DISC. SIZE	
								FLA	LRA			FLA	LRA
181/183	208/230-3-60	STD	NONE	—	—	69.4/68.6	90/90	73/72	390	81.2/80.4	100/100	86/85	410
			279A00	18.8/25.0	52.1/60.1	75.9/84.9	90/90	73/78	390/390	90.6/99.6	100/100	86/92	410/410
			280A00	37.6/50.0	104.2/120.3	141.0/130.1	150/150	130/147	390/390	155.8/144.8	175/150	143/161	410/410
			281A00	56.3/75.0	156.4/180.4	167.2/190.2	200/200	190/216	390/390	181.9/204.9	200/225	203/230	410/410
		MED	NONE	—	—	71.6/70.6	90/90	75/74	414	83.4/82.4	100/100	89/88	434
			279A00	18.8/25.0	52.1/60.1	78.6/87.4	90/90	75/80	414/414	93.4/102.1	100/110	89/94	434/434
			280A00	37.6/50.0	104.2/120.3	143.8/132.6	150/150	132/150	414/414	158.5/147.3	175/175	146/163	434/434
			281A00	56.3/75.0	156.4/180.4	169.9/192.7	200/225	192/219	414/414	184.7/207.4	200/225	206/232	434/434
		HIGH	NONE	—	—	74.4/73.5	90/90	78/77	425	86.2/85.3	100/100	92/91	445
			279A00	18.8/25.0	52.1/60.1	82.1/91.0	90/100	78/84	425/425	96.9/105.8	100/110	92/97	445/445
			280A00	37.6/50.0	104.2/120.3	147.3/136.2	150/150	135/153	425/425	162.0/150.9	175/175	149/167	445/445
			281A00	56.3/75.0	156.4/180.4	173.4/196.3	200/225	196/222	425/425	188.2/211.0	200/225	209/236	445/445
	460-3-60	STD	NONE	—	—	35.3	45	37	233	41.5	50	44	245
			282A00	25.0	30.1	42.4	45	39	233	50.1	60	46	245
			283A00	50.0	60.1	64.9	70	73	233	72.6	80	81	245
			284A00	75.0	90.2	95.0	100	108	233	102.7	110	115	245
		MED	NONE	—	—	36.4	45	38	245	42.6	50	45	257
			282A00	25.0	30.1	43.8	45	40	245	51.5	60	47	257
			283A00	50.0	60.1	66.2	80	75	245	74.0	80	82	257
			284A00	75.0	90.2	96.3	100	109	245	104.1	110	116	257
		HIGH	NONE	—	—	37.9	50	40	250	44.1	50	47	262
			282A00	25.0	30.1	45.6	50	42	250	53.4	60	49	262
			283A00	50.0	60.1	68.1	80	76	250	75.9	80	84	262
			284A00	75.0	90.2	98.2	100	111	250	106.0	125	118	262
575-3-60	STD	NONE	—	—	27.9	35	29	184	32.7	40	35	192	
		285A00	24.8	23.9	35.5	40	33	184	41.5	45	38	192	
		286A00	49.6	47.7	65.3	70	60	184	71.3	80	66	192	
		287A00	74.4	71.6	77.2	90	88	184	83.2	90	93	192	
	MED	NONE	—	—	27.9	35	29	184	32.7	40	35	192	
		285A00	24.8	23.9	35.5	40	33	184	41.5	45	38	192	
		286A00	49.6	47.7	65.3	70	60	184	71.3	80	66	192	
		287A00	74.4	71.6	77.2	90	88	184	83.2	90	93	192	
	HIGH	NONE	—	—	29.6	35	31	198	34.4	40	37	206	
		285A00	24.8	23.9	37.6	40	35	198	43.6	45	40	206	
		286A00	49.6	47.7	67.4	70	62	198	73.4	80	68	206	
		287A00	74.4	71.6	79.4	90	89	198	85.4	90	95	206	

ELECTRICAL INFORMATION (UNITS PRODUCED ON OR AFTER JULY 30, 2012) cont.

TABLE 32 – UNIT WIRE SIZING DATA WITH FACTORY INSTALLED 2 SPEED INDOOR FAN OPTION (cont)

UNIT RAH	NO M. V. PH-HZ	IFM TYPE	ELEC. HTR			NO C.O. or UNPWR C.O.							
			CRHEATER***A00	Nom (kW)	FLA	NO P.E.				w/ P.E. (pwrd fr/unit)			
						MCA	MAX FUSE or HACR BRKR	DISC. SIZE		MCA	MAX FUSE or HACR BRKR	DISC. SIZE	
								FLA	LRA			FLA	LRA
210/213	208/230-3-60	STD	NONE	—	—	76.3/75.3	100/100	80/79	444	88.1/87.1	100/100	93/92	464
			279A00	18.8/25.0	52.1/60.1	78.6/87.4	100/100	80/80	444/444	93.4/102.1	100/110	93/94	464/464
			280A00	37.6/50.0	104.2/120.3	143.8/132.6	150/150	132/150	444/444	158.5/147.3	175/175	146/163	464/464
			281A00	56.3/75.0	156.4/180.4	169.9/192.7	200/225	192/219	444/444	184.7/207.4	200/225	206/232	464/464
		MED	NONE	—	—	79.1/78.2	100/100	83/82	455	90.9/90.0	100/100	97/96	475
			279A00	18.8/25.0	52.1/60.1	82.1/91.0	100/100	83/84	455/455	96.9/105.8	100/110	97/97	475/475
			280A00	37.6/50.0	104.2/120.3	147.3/136.2	150/150	135/153	455/455	162.0/150.9	175/175	149/167	475/475
		HIGH	281A00	56.3/75.0	156.4/180.4	173.4/196.3	200/225	196/222	455/455	188.2/211.0	200/225	209/236	475/475
			NONE	—	—	82.6	100	87	451	94.4	110	101	471
	279A00		18.8/25.0	52.1/60.1	86.5/96.5	100/100	87/89	451/451	101.3/111.3	110/125	101/102	471/471	
	280A00		37.6/50.0	104.2/120.3	151.6/141.7	175/175	139/158	451/451	166.4/156.4	175/175	153/172	471/471	
	460-3-60	STD	281A00	56.3/75.0	156.4/180.4	177.8/201.8	200/225	200/227	451/451	192.5/216.5	200/250	213/241	471/471
			NONE	—	—	36.7	45	39	247	42.9	50	46	259
			282A00	25.0	30.1	43.8	45	40	247	51.5	60	47	259
			283A00	50.0	60.1	66.2	80	75	247	74.0	80	82	259
		MED	284A00	75.0	90.2	96.3	100	109	247	104.1	110	116	259
			NONE	—	—	38.2	50	40	252	44.4	50	47	264
			282A00	25.0	30.1	45.6	50	42	252	53.4	60	49	264
			283A00	50.0	60.1	68.1	80	76	252	75.9	80	84	264
		HIGH	284A00	75.0	90.2	98.2	100	111	252	106.0	125	118	264
			NONE	—	—	40.4	50	43	250	46.6	50	50	262
			282A00	25.0	30.1	48.4	50	45	250	56.1	60	52	262
			283A00	50.0	60.1	70.9	80	79	250	78.6	80	86	262
	575-3-60	STD	284A00	75.0	90.2	101.0	110	114	250	108.7	125	121	262
NONE			—	—	27.9	35	29	186	32.7	40	35	194	
285A00			24.8	23.9	35.5	40	33	186	41.5	45	38	194	
286A00			49.6	47.7	65.3	70	60	186	71.3	80	66	194	
MED		287A00	74.4	71.6	77.2	90	88	186	83.2	90	93	194	
		NONE	—	—	29.6	35	31	200	34.4	40	37	208	
		285A00	24.8	23.9	37.6	40	35	200	43.6	45	40	208	
		286A00	49.6	47.7	67.4	70	62	200	73.4	80	68	208	
HIGH		287A00	74.4	71.6	79.4	90	89	200	85.4	90	95	208	
		NONE	—	—	31.0	40	33	198	35.8	45	38	206	
		285A00	24.8	23.9	39.4	40	36	198	45.4	50	42	206	
		286A00	49.6	47.7	69.1	70	64	198	75.1	80	69	206	
287A00	74.4	71.6	81.1	90	91	198	87.1	90	97	206			

ELECTRICAL INFORMATION (UNITS PRODUCED ON OR AFTER JULY 30, 2012) cont.

TABLE 32 – UNIT WIRE SIZING DATA WITH FACTORY INSTALLED 2 SPEED INDOOR FAN OPTION (cont)

UNIT RAH	NO M. V-Ph-HZ	IFM TYPE	ELEC. HTR			NO C.O. or UNPWR C.O.							
			CRHEATER***A00	Nom (kW)	FLA	NO P.E.				w/ P.E. (pwrd fr/unit)			
						MCA	MAX FUSE or HACR BRKR	DISC. SIZE		MCA	MAX FUSE or HACR BRKR	DISC. SIZE	
								FLA	LRA			FLA	LRA
240/243	208/230-3-60	STD	NONE	—	—	87.3/86.4	100/100	92/91	550	99.1/98.2	125/125	105/104	570
			279A00	18.8/25.0	52.1/60.1	87.3/91.0	100/100	92/91	550/550	99.1/105.8	125/125	105/104	570/570
			280A00	37.6/50.0	104.2/120.3	147.3/136.2	150/150	135/153	550/550	162.0/150.9	175/175	149/167	570/570
			281A00	56.3/75.0	156.4/180.4	173.4/196.3	200/225	196/222	550/550	188.2/211.0	200/225	209/236	570/570
		MED	NONE	—	—	90.8	100	96	546	102.6	125	109	566
			279A00	18.8/25.0	52.1/60.1	90.8/96.5	100/100	96/96	546/546	102.6/111.3	125/125	109/109	566/566
			280A00	37.6/50.0	104.2/120.3	151.6/141.7	175/175	139/158	546/546	166.4/156.4	175/175	153/172	566/566
			281A00	56.3/75.0	156.4/180.4	177.8/201.8	200/225	200/227	546/546	192.5/216.5	200/250	213/241	566/566
		HIGH	NONE	—	—	102.2	125	109	625	114.0	125	122	645
			279A00	18.8/25.0	52.1/60.1	102.2/110.8	125/125	109/109	625/625	115.5/125.5	125/150	122/122	645/645
			280A00	37.6/50.0	104.2/120.3	165.9/155.9	175/175	153/171	625/625	180.6/170.7	200/175	166/185	645/645
			281A00	56.3/75.0	156.4/180.4	192.0/216.0	200/250	213/240	625/625	206.8/230.8	225/250	226/254	645/645
	460-3-60	STD	NONE	—	—	47.6	60	50	280	53.8	60	57	292
			282A00	25.0	30.1	47.6	60	50	280	53.8	60	57	292
			283A00	50.0	60.1	68.1	80	76	280	75.9	80	84	292
			284A00	75.0	90.2	98.2	100	111	280	106.0	125	118	292
		MED	NONE	—	—	49.8	60	52	278	56.0	70	60	290
			282A00	25.0	30.1	49.8	60	52	278	56.1	70	60	290
			283A00	50.0	60.1	70.9	80	79	278	78.6	80	86	290
			284A00	75.0	90.2	101.0	110	114	278	108.7	125	121	290
		HIGH	NONE	—	—	55.5	60	59	318	61.7	70	66	330
			282A00	25.0	30.1	55.5	60	59	318	63.3	70	66	330
			283A00	50.0	60.1	78.0	90	86	318	85.7	90	93	330
			284A00	75.0	90.2	108.1	125	120	318	115.8	125	127	330
	575-3-60	STD	NONE	—	—	36.1	45	38	204	40.9	50	43	212
			285A00	24.8	23.9	37.6	45	38	204	43.6	50	43	212
			286A00	49.6	47.7	67.4	70	62	204	73.4	80	68	212
			287A00	74.4	71.6	79.4	90	89	204	85.4	90	95	212
MED		NONE	—	—	37.5	45	40	202	42.3	50	45	210	
		285A00	24.8	23.9	39.4	45	40	202	45.4	50	45	210	
		286A00	49.6	47.7	69.1	70	64	202	75.1	80	69	210	
		287A00	74.4	71.6	81.1	90	91	202	87.1	90	97	210	
HIGH		NONE	—	—	39.4	50	42	229	44.2	50	47	237	
		285A00	24.8	23.9	41.8	50	42	229	47.8	50	47	237	
		286A00	49.6	47.7	71.5	80	66	229	77.5	80	71	237	
		287A00	74.4	71.6	83.5	90	93	229	89.5	100	99	237	

ELECTRICAL INFORMATION (UNITS PRODUCED ON OR AFTER JULY 30, 2012) cont.

TABLE 32 – UNIT WIRE SIZING DATA WITH FACTORY INSTALLED 2 SPEED INDOOR FAN OPTION (cont)

UNIT RAH	NO M. V-PH-HZ	IFM TYP E	ELEC. HTR			NO C.O. or UNPWR C.O.							
			CRHEATER***A00	Nom (kW)	FLA	NO P.E.				w/ P.E. (pwrd fr/unit)			
						MCA	MAX FUSE or HACR BRKR	DISC. SIZE		MCA	MAX FUSE or HACR BRKR	DISC. SIZE	
								FLA	LRA			FLA	LRA
300/303	208/230-3-60	STD	NONE	—	—	116.0/115.1	150/150	120/119	590	127.8/126.9	175/175	133/132	610
			279A00	18.8/25.0	52.1/60.1	116.0/115.1	150/150	120/119	590/590	127.8/126.9	175/175	133/132	610/610
			280A00	37.6/50.0	104.2/120.3	147.3/136.2	150/150	135/153	590/590	162.0/150.9	175/175	149/167	610/610
			281A00	56.3/75.0	156.4/180.4	173.4/196.3	200/225	196/222	590/590	188.2/211.0	200/225	209/236	610/610
		MED	NONE	—	—	119.5	150	124	586	131.3	175	137	606
			279A00	18.8/25.0	52.1/60.1	119.5/119.5	150/150	124/124	586/586	131.3/131.3	175/175	137/137	606/606
			280A00	37.6/50.0	104.2/120.3	151.6/141.7	175/175	139/158	586/586	166.4/156.4	175/175	153/172	606/606
		HIGH	281A00	56.3/75.0	156.4/180.4	177.8/201.8	200/225	200/227	586/586	192.5/216.5	200/250	213/241	606/606
			NONE	—	—	130.9	175	137	665	142.7	175	150	685
	279A00		18.8/25.0	52.1/60.1	130.9/130.9	175/175	137/137	665/665	142.7/142.7	175/175	150/150	685/685	
	460-3-60	STD	280A00	37.6/50.0	104.2/120.3	165.9/155.9	175/175	153/171	665/665	180.6/170.7	200/175	166/185	685/685
			281A00	56.3/75.0	156.4/180.4	192.0/216.0	200/250	213/240	665/665	206.8/230.8	225/250	226/254	685/685
			NONE	—	—	53.0	60	56	306	59.2	70	63	318
			282A00	25.0	30.1	53.0	60	56	306	59.2	70	63	318
		MED	283A00	50.0	60.1	68.1	80	76	306	75.9	80	84	318
			284A00	75.0	90.2	98.2	100	111	306	106.0	125	118	318
			NONE	—	—	55.2	60	58	304	61.4	70	65	316
			282A00	25.0	30.1	55.2	60	58	304	61.4	70	65	316
		HIGH	283A00	50.0	60.1	70.9	80	79	304	78.6	80	86	316
			284A00	75.0	90.2	101.0	110	114	304	108.7	125	121	316
			NONE	—	—	60.9	70	65	344	67.1	80	72	356
			282A00	25.0	30.1	60.9	70	65	344	67.1	80	72	356
	575-3-60	STD	283A00	50.0	60.1	78.0	90	86	344	85.7	90	93	356
			284A00	75.0	90.2	108.1	125	120	344	115.8	125	127	356
NONE			—	—	41.0	50	43	228	45.8	60	48	236	
285A00			24.8	23.9	41.0	50	43	228	45.8	60	48	236	
MED		286A00	49.6	47.7	67.4	70	62	228	73.4	80	68	236	
		287A00	74.4	71.6	79.4	90	89	228	85.4	90	95	236	
		NONE	—	—	42.4	50	45	226	47.2	60	50	234	
		285A00	24.8	23.9	42.4	50	45	226	47.2	60	50	234	
HIGH		286A00	49.6	47.7	69.1	70	64	226	75.1	80	69	234	
		287A00	74.4	71.6	81.1	90	91	226	87.1	90	97	234	
		NONE	—	—	44.3	50	47	253	49.1	60	52	261	
		285A00	24.8	23.9	44.3	50	47	253	49.1	60	52	261	
	286A00	49.6	47.7	71.5	80	66	253	77.5	80	71	261		
	287A00	74.4	71.6	83.5	90	93	253	89.5	100	99	261		

ELECTRICAL INFORMATION (UNITS PRODUCED ON OR AFTER JULY 30, 2012) cont.

TABLE 33 – UNIT WIRE/FUSE SIZING DATA WITH FACTORY INSTALLED 2 SPEED INDOOR FAN OPTION

UNIT RAH	NO M. V.-Ph.-HZ	IFM TYPE	ELEC. HTR			NO C.O. or UNPWR C.O.							
			CRHEATER***A00	Nom (kW)	FLA	NO P.E.				w/ P.E. (pwrd fr/unit)			
						MCA	HACR BRKR	DISC. SIZE		MCA	HACR BRKR	DISC. SIZE	
								FLA	LRA			FLA	LRA
181/183	208/230-3-60	STD	NONE	—	—	69.4/69.4	90/90	73/72	390	81.2/81.2	100/100	86/85	410
			279A00	18.8/25.0	52.1/60.1	84.9/84.9	90/90	73/78	390/390	99.6/99.6	100/100	86/92	410/410
			280A00	37.6/50.0	104.2/120.3	141.0/141.0	150/150	130/147	390/390	155.8/155.8	175/175	143/161	410/410
		281A00	56.3/75.0	156.4/180.4	190.2/190.2	200/200	190/216	390/390	204.9/204.9	225/225	203/230	410/410	
		MED	NONE	—	—	71.6/71.6	90/90	75/74	414	83.4/83.4	100/100	89/88	434
			279A00	18.8/25.0	52.1/60.1	87.4/87.4	90/90	75/80	414/414	102.1/102.1	110/110	89/94	434/434
			280A00	37.6/50.0	104.2/120.3	143.8/143.8	150/150	132/150	414/414	158.5/158.5	175/175	146/163	434/434
		281A00	56.3/75.0	156.4/180.4	192.7/192.7	200/225	192/219	414/414	207.4/207.4	225/225	206/232	434/434	
		HIGH	NONE	—	—	74.4/74.4	90/90	78/77	425	86.2/86.2	100/100	92/91	445
	279A00		18.8/25.0	52.1/60.1	91.0/91.0	100/100	78/84	425/425	105.8/105.8	110/110	92/97	445/445	
	280A00		37.6/50.0	104.2/120.3	147.3/147.3	150/150	135/153	425/425	162.0/162.0	175/175	149/167	445/445	
	281A00	56.3/75.0	156.4/180.4	196.3/196.3	200/225	196/222	425/425	211.0/211.0	225/225	209/236	445/445		
	460-3-60	STD	NONE	—	—	35.3	45	37	233	41.5	50	44	245
			282A00	25.0	30.1	42.4	45	39	233	50.1	60	46	245
			283A00	50.0	60.1	64.9	70	73	233	72.6	80	81	245
			284A00	75.0	90.2	95.0	100	108	233	102.7	110	115	245
		MED	NONE	—	—	36.4	45	38	245	42.6	50	45	257
			282A00	25.0	30.1	43.8	45	40	245	51.5	60	47	257
			283A00	50.0	60.1	66.2	80	75	245	74.0	80	82	257
		284A00	75.0	90.2	96.3	100	109	245	104.1	110	116	257	
		HIGH	NONE	—	—	37.9	50	40	250	44.1	50	47	262
	282A00		25.0	30.1	45.6	50	42	250	53.4	60	49	262	
	283A00		50.0	60.1	68.1	80	76	250	75.9	80	84	262	
	284A00	75.0	90.2	98.2	100	111	250	106.0	125	118	262		
575-3-60	STD	NONE	—	—	27.9	35	29	184	32.7	40	35	192	
		285A00	24.8	23.9	35.5	40	33	184	41.5	45	38	192	
		286A00	49.6	47.7	65.3	70	60	184	71.3	80	66	192	
		287A00	74.4	71.6	77.2	90	88	184	83.2	90	93	192	
	MED	NONE	—	—	27.9	35	29	184	32.7	40	35	192	
		285A00	24.8	23.9	35.5	40	33	184	41.5	45	38	192	
		286A00	49.6	47.7	65.3	70	60	184	71.3	80	66	192	
	287A00	74.4	71.6	77.2	90	88	184	83.2	90	93	192		
	HIGH	NONE	—	—	29.6	35	31	198	34.4	40	37	206	
285A00		24.8	23.9	37.6	40	35	198	43.6	45	40	206		
286A00		49.6	47.7	67.4	70	62	198	73.4	80	68	206		
287A00	74.4	71.6	79.4	90	89	198	85.4	90	95	206			

ELECTRICAL INFORMATION (UNITS PRODUCED ON OR AFTER JULY 30, 2012) cont.

TABLE 33 – UNIT WIRE/FUSE SIZING DATA WITH FACTORY INSTALLED 2 SPEED INDOOR FAN OPTION (cont)

UNIT RAH	NO M. V.-Ph.-HZ	IFM TYPE	ELEC. HTR			NO C.O. or UNPWR C.O.							
			CRHEATER***A00	Nom (kW)	FLA	NO P.E.			w/ P.E. (pwrdr fr/unit)				
						MCA	HACR BRKR	DISC. SIZE		MCA	HACR BRKR	DISC. SIZE	
								FLA	LRA			FLA	LRA
210/213	208/230-3-60	STD	NONE	—	—	76.3/76.3	100/100	80/79	444	88.1/88.1	100/100	93/92	464
			279A00	18.8/25.0	52.1/60.1	87.4/87.4	100/100	80/80	444/444	102.1/102.1	110/110	93/94	464/464
			280A00	37.6/50.0	104.2/120.3	143.8/143.8	150/150	132/150	444/444	158.5/158.5	175/175	146/163	464/464
			281A00	56.3/75.0	156.4/180.4	192.7/192.7	200/225	192/219	444/444	207.4/207.4	225/225	206/232	464/464
		MED	NONE	—	—	79.1/79.1	100/100	83/82	455	90.9/90.9	100/100	97/96	475
			279A00	18.8/25.0	52.1/60.1	91.0/91.0	100/100	83/84	455/455	105.8/105.8	110/110	97/97	475/475
			280A00	37.6/50.0	104.2/120.3	147.3/147.3	150/150	135/153	455/455	162.0/162.0	175/175	149/167	475/475
			281A00	56.3/75.0	156.4/180.4	196.3/196.3	200/225	196/222	455/455	211.0/211.0	225/225	209/236	475/475
		HIGH	NONE	—	—	82.6	100	87	451	94.4	110	101	471
	279A00		18.8/25.0	52.1/60.1	96.5/96.5	100/100	87/89	451/451	111.3/111.3	125/125	101/102	471/471	
	280A00		37.6/50.0	104.2/120.3	151.6/151.6	175/175	139/158	451/451	166.4/166.4	175/175	153/172	471/471	
	281A00		56.3/75.0	156.4/180.4	201.8/201.8	225/225	200/227	451/451	216.5/216.5	225/250	213/241	471/471	
	460-3-60	STD	NONE	—	—	36.7	45	39	247	42.9	50	46	259
			282A00	25.0	30.1	43.8	45	40	247	51.5	60	47	259
			283A00	50.0	60.1	66.2	80	75	247	74.0	80	82	259
			284A00	75.0	90.2	96.3	100	109	247	104.1	110	116	259
		MED	NONE	—	—	38.2	50	40	252	44.4	50	47	264
			282A00	25.0	30.1	45.6	50	42	252	53.4	60	49	264
			283A00	50.0	60.1	68.1	80	76	252	75.9	80	84	264
			284A00	75.0	90.2	98.2	100	111	252	106.0	125	118	264
		HIGH	NONE	—	—	40.4	50	43	250	46.6	50	50	262
			282A00	25.0	30.1	48.4	50	45	250	56.1	60	52	262
			283A00	50.0	60.1	70.9	80	79	250	78.6	80	86	262
			284A00	75.0	90.2	101.0	110	114	250	108.7	125	121	262
575-3-60	STD	NONE	—	—	27.9	35	29	186	32.7	40	35	194	
		285A00	24.8	23.9	35.5	40	33	186	41.5	45	38	194	
		286A00	49.6	47.7	65.3	70	60	186	71.3	80	66	194	
		287A00	74.4	71.6	77.2	90	88	186	83.2	90	93	194	
	MED	NONE	—	—	29.6	35	31	200	34.4	40	37	208	
		285A00	24.8	23.9	37.6	40	35	200	43.6	45	40	208	
		286A00	49.6	47.7	67.4	70	62	200	73.4	80	68	208	
		287A00	74.4	71.6	79.4	90	89	200	85.4	90	95	208	
	HIGH	NONE	—	—	31.0	40	33	198	35.8	45	38	206	
		285A00	24.8	23.9	39.4	40	36	198	45.4	50	42	206	
		286A00	49.6	47.7	69.1	70	64	198	75.1	80	69	206	
		287A00	74.4	71.6	81.1	90	91	198	87.1	90	97	206	

ELECTRICAL INFORMATION (UNITS PRODUCED ON OR AFTER JULY 30, 2012) cont.

TABLE 33 – UNIT WIRE/FUSE SIZING DATA WITH FACTORY INSTALLED 2 SPEED INDOOR FAN OPTION (cont)

UNIT RAH	NO M. V. -PH-HZ	IFM TYPE	ELEC. HTR			NO C.O. or UNPWR C.O.							
			CRHEATER***A00	Nom (kW)	FLA	NO P.E.				w/ P.E. (pwrd fr/unit)			
						MCA	HACR BRKR	DISC. SIZE		MCA	HACR BRKR	DISC. SIZE	
								FLA	LRA			FLA	LRA
240/243	208/230-3-60	STD	NONE	-	-	87.3/87.3	100/100	92/91	550	99.1/99.1	125/125	105/104	570
			279A00	18.8/25.0	52.1/60.1	91.0/91.0	100/100	92/91	550/550	105.8/105.8	125/125	105/104	570/570
			280A00	37.6/50.0	104.2/120.3	147.3/147.3	150/150	135/153	550/550	162.0/162.0	175/175	149/167	570/570
			281A00	56.3/75.0	156.4/180.4	196.3/196.3	200/225	196/222	550/550	211.0/211.0	225/225	209/236	570/570
		MED	NONE	-	-	90.8	100	96	546	102.6	125	109	566
			279A00	18.8/25.0	52.1/60.1	96.5/96.5	100/100	96/96	546/546	111.3/111.3	125/125	109/109	566/566
			280A00	37.6/50.0	104.2/120.3	151.6/151.6	175/175	139/158	546/546	166.4/166.4	175/175	153/172	566/566
		HIGH	281A00	56.3/75.0	156.4/180.4	201.8/201.8	225/225	200/227	546/546	216.5/216.5	225/250	213/241	566/566
			NONE	-	-	102.2	125	109	625	114.0	125	122	645
	279A00		18.8/25.0	52.1/60.1	110.8/110.8	125/125	109/109	625/625	125.5/125.5	150/150	122/122	645/645	
	460-3-60	STD	280A00	37.6/50.0	104.2/120.3	165.9/165.9	175/175	153/171	625/625	180.6/180.6	200/200	166/185	645/645
			281A00	56.3/75.0	156.4/180.4	216.0/216.0	225/250	213/240	625/625	230.8/230.8	250/250	226/254	645/645
			NONE	-	-	47.6	60	50	280	53.8	60	57	292
			282A00	25.0	30.1	47.6	60	50	280	53.8	60	57	292
		MED	283A00	50.0	60.1	68.1	80	76	280	75.9	80	84	292
			284A00	75.0	90.2	98.2	100	111	280	106.0	125	118	292
			NONE	-	-	49.8	60	52	278	56.0	70	60	290
			282A00	25.0	30.1	49.8	60	52	278	56.1	70	60	290
		HIGH	283A00	50.0	60.1	70.9	80	79	278	78.6	80	86	290
			284A00	75.0	90.2	101.0	110	114	278	108.7	125	121	290
			NONE	-	-	55.5	60	59	318	61.7	70	66	330
			282A00	25.0	30.1	55.5	60	59	318	63.3	70	66	330
	575-3-60	STD	283A00	50.0	60.1	78.0	90	86	318	85.7	90	93	330
			284A00	75.0	90.2	108.1	125	120	318	115.8	125	127	330
NONE			-	-	36.1	45	38	204	40.9	50	43	212	
285A00			24.8	23.9	37.6	45	38	204	43.6	50	43	212	
MED		286A00	49.6	47.7	67.4	70	62	204	73.4	80	68	212	
		287A00	74.4	71.6	79.4	90	89	204	85.4	90	95	212	
		NONE	-	-	37.5	45	40	202	42.3	50	45	210	
		285A00	24.8	23.9	39.4	45	40	202	45.4	50	45	210	
HIGH		286A00	49.6	47.7	69.1	70	64	202	75.1	80	69	210	
		287A00	74.4	71.6	81.1	90	91	202	87.1	90	97	210	
		NONE	-	-	39.4	50	42	229	44.2	50	47	237	
		285A00	24.8	23.9	41.8	50	42	229	47.8	50	47	237	
HIGH	286A00	49.6	47.7	71.5	80	66	229	77.5	80	71	237		
	287A00	74.4	71.6	83.5	90	93	229	89.5	100	99	237		

ELECTRICAL INFORMATION (UNITS PRODUCED ON OR AFTER JULY 30, 2012) cont.

TABLE 33 – UNIT WIRE/FUSE SIZING DATA WITH FACTORY INSTALLED 2 SPEED INDOOR FAN OPTION (cont)

UNIT RAH	NO M. V-Ph-HZ	IFM TYPE	ELEC. HTR			NO C.O. or UNPWR C.O.							
			CRHEATER***A00	Nom (kW)	FLA	NO PE.				w/ PE. (pwrd fr/unit)			
						MCA	HACR BRKR	DISC. SIZE		MCA	HACR BRKR	DISC. SIZE	
								FLA	LRA			FLA	LRA
300/303	208/230-3-60	STD	NONE	—	—	116.0/116.0	150/150	120/119	590	127.8/127.8	175/175	133/132	610
			279A00	18.8/25.0	52.1/60.1	116.0/116.0	150/150	120/119	590/590	127.8/127.8	175/175	133/132	610/610
			280A00	37.6/50.0	104.2/120.3	147.3/147.3	150/150	135/153	590/590	162.0/162.0	175/175	149/167	610/610
			281A00	56.3/75.0	156.4/180.4	196.3/196.3	200/225	196/222	590/590	211.0/211.0	225/225	209/236	610/610
		MED	NONE	—	—	119.5	150	124	586	131.3	175	137	606
			279A00	18.8/25.0	52.1/60.1	119.5/119.5	150/150	124/124	586/586	131.3/131.3	175/175	137/137	606/606
			280A00	37.6/50.0	104.2/120.3	151.6/151.6	175/175	139/158	586/586	166.4/166.4	175/175	153/172	606/606
			281A00	56.3/75.0	156.4/180.4	201.8/201.8	225/225	200/227	586/586	216.5/216.5	225/250	213/241	606/606
		HIGH	NONE	—	—	130.9	175	137	665	142.7	175	150	685
			279A00	18.8/25.0	52.1/60.1	130.9/130.9	175/175	137/137	665/665	142.7/142.7	175/175	150/150	685/685
			280A00	37.6/50.0	104.2/120.3	165.9/165.9	175/175	153/171	665/665	180.6/180.6	200/200	166/185	685/685
			281A00	56.3/75.0	156.4/180.4	216.0/216.0	225/250	213/240	665/665	230.8/230.8	250/250	226/254	685/685
	460-3-60	STD	NONE	—	—	53.0	60	56	306	59.2	70	63	318
			282A00	25.0	30.1	53.0	60	56	306	59.2	70	63	318
			283A00	50.0	60.1	68.1	80	76	306	75.9	80	84	318
			284A00	75.0	90.2	98.2	100	111	306	106.0	125	118	318
		MED	NONE	—	—	55.2	60	58	304	61.4	70	65	316
			282A00	25.0	30.1	55.2	60	58	304	61.4	70	65	316
			283A00	50.0	60.1	70.9	80	79	304	78.6	80	86	316
			284A00	75.0	90.2	101.0	110	114	304	108.7	125	121	316
		HIGH	NONE	—	—	60.9	70	65	344	67.1	80	72	356
			282A00	25.0	30.1	60.9	70	65	344	67.1	80	72	356
			283A00	50.0	60.1	78.0	90	86	344	85.7	90	93	356
			284A00	75.0	90.2	108.1	125	120	344	115.8	125	127	356
	575-3-60	STD	NONE	—	—	41.0	50	43	228	45.8	60	48	236
			285A00	24.8	23.9	41.0	50	43	228	45.8	60	48	236
			286A00	49.6	47.7	67.4	70	62	228	73.4	80	68	236
			287A00	74.4	71.6	79.4	90	89	228	85.4	90	95	236
MED		NONE	—	—	42.4	50	45	226	47.2	60	50	234	
		285A00	24.8	23.9	42.4	50	45	226	47.2	60	50	234	
		286A00	49.6	47.7	69.1	70	64	226	75.1	80	69	234	
		287A00	74.4	71.6	81.1	90	91	226	87.1	90	97	234	
HIGH		NONE	—	—	44.3	50	47	253	49.1	60	52	261	
		285A00	24.8	23.9	44.3	50	47	253	49.1	60	52	261	
		286A00	49.6	47.7	71.5	80	66	253	77.5	80	71	261	
		287A00	74.4	71.6	83.5	90	93	253	89.5	100	99	261	

ELECTRICAL DATA FOR UNITS PRODUCED PRIOR TO JULY 30, 2012

NOTE: Check the serial number of unit to verify production date.

SERIAL NUMBER

1	2	3	4	5	6	7	8	9	10
U	1	2	3	1	1	2	3	4	5

Manufacture Location

Year of Manufacture
(12 = 2012)

Week of Manufacture
(fiscal calendar)

Sequence Number

ELECTRICAL INFORMATION (UNITS PRODUCED PRIOR TO JULY 30, 2012)

TABLE 34 – 2-STAGE COOLING WITH SINGLE SPEED INDOOR FAN MOTOR

UNIT RAH	V–PH–HZ	VOLTAGE RANGE		COMP 1		COMP 2		OFM (ea)		IFM		
		MIN	MAX	RLA	LRA	RLA	LRA	WATTS	FLA	TYPE	EFF at Full Load	FLA
180/183	208–3–60	187	253	29.5	195	30.1	225	350	1.5	STD	81.3%	7.5
										MED	83.8%	10.2
										HIGH	83.6%	15.0
	230–3–60	187	253	29.5	195	30.1	225	350	1.5	STD	81.3%	7.5
										MED	83.8%	10.2
										HIGH	83.6%	15.0
	460–3–60	414	506	14.7	95	16.7	114	277	0.9	STD	81.3%	3.4
										MED	83.8%	4.8
										HIGH	83.6%	7.4
	575–3–60	518	633	12.2	80	12.2	80	397	0.6	STD	81.1%	2.8
										MED	81.1%	2.8
										HIGH	83.6%	5.6
210/213	208–3–60	187	253	29.5	195	30.1	225	350	1.5	STD	83.8%	10.2
										MED	83.6%	15.0
										HIGH	89.5%	20.4
	230–3–60	187	253	29.5	195	30.1	225	350	1.5	STD	83.8%	10.2
										MED	83.6%	15.0
										HIGH	89.5%	20.4
	460–3–60	414	506	14.7	95	16.7	114	277	0.9	STD	83.8%	4.8
										MED	83.6%	7.4
										HIGH	89.5%	20.4
	575–3–60	518	633	12.2	80	12.2	80	397	0.6	STD	81.1%	2.8
										MED	83.6%	5.6
										HIGH	89.5%	9.0
240/243	208–3–60	187	253	48.1	245	29.5	195	350	1.5	STD	83.6%	15.0
										MED	89.5%	20.4
										HIGH	91.7%	33.1
	230–3–60	187	253	48.1	245	29.5	195	350	1.5	STD	83.6%	15.0
										MED	89.5%	20.4
										HIGH	91.7%	33.1
	460–3–60	414	506	18.6	125	14.7	95	277	0.9	STD	83.6%	7.4
										MED	89.5%	20.4
										HIGH	91.7%	33.1
	575–3–60	518	633	14.7	100	12.2	80	397	0.6	STD	83.6%	5.6
										MED	89.5%	9.0
										HIGH	91.7%	9.5
300/303	208–3–60	187	253	48.1	245	48.1	245	350	1.5	STD	83.6%	15.0
										MED	89.5%	20.4
										HIGH	91.7%	33.1
	230–3–60	187	253	48.1	245	48.1	245	350	1.5	STD	83.6%	15.0
										MED	89.5%	20.4
										HIGH	91.7%	33.1
	460–3–60	414	506	18.6	125	18.6	125	277	0.9	STD	83.6%	7.4
										MED	89.5%	20.4
										HIGH	91.7%	33.1
	575–3–60	518	633	14.7	100	14.7	100	397	0.6	STD	83.6%	5.6
										MED	89.5%	9.0
										HIGH	91.7%	9.5

ELECTRICAL INFORMATION (UNITS PRODUCED PRIOR TO JULY 30, 2012) cont.

TABLE 35 – 2-STAGE COOLING WITH 2-SPEED INDOOR FAN MOTOR

UNIT RAH	V–Ph–Hz	VOLTAGE RANGE		COMP 1		COMP 2		OFM (ea)		IFM		
		MIN	MAX	RLA	LRA	RLA	LRA	WATTS	FLA	TYPE	EFF at Full Load	FLA
180/183	208–3–60	187	253	25.0	164	25.0	164	350	1.5	STD	85.0%	8.6
										MED	81.5%	10.8
										HIGH	83.6%	13.6
	230–3–60	187	253	25.0	164	25.0	164	350	1.5	STD	85.0%	7.8
										MED	81.5%	9.8
										HIGH	83.6%	12.7
	460–3–60	414	506	12.8	100	12.8	100	277	0.9	STD	85.0%	3.8
										MED	81.5%	4.9
										HIGH	83.6%	6.4
	575–3–60	518	633	9.6	78	9.6	78	397	0.6	STD	81.1%	4.5
										MED	81.1%	4.5
										HIGH	83.6%	6.2
210/213	208–3–60	187	253	27.6	191	25.0	164	350	1.5	STD	81.5%	10.8
										MED	83.6%	13.6
										HIGH	89.5%	17.1
	230–3–60	187	253	27.6	191	25.0	164	350	1.5	STD	81.5%	9.8
										MED	83.6%	12.7
										HIGH	89.5%	17.1
	460–3–60	414	506	12.8	100	12.2	100	277	0.9	STD	81.5%	4.9
										MED	83.6%	6.4
										HIGH	89.5%	8.6
	575–3–60	518	633	9.6	78	9.0	78	397	0.6	STD	81.1%	4.5
										MED	83.6%	6.2
										HIGH	89.5%	7.6
240/243	208–3–60	187	253	30.1	225	30.1	225	350	1.5	STD	83.6%	13.6
										MED	89.5%	17.1
										HIGH	91.7%	28.5
	230–3–60	187	253	30.1	225	30.1	225	350	1.5	STD	83.6%	12.7
										MED	89.5%	17.1
										HIGH	91.7%	28.5
	460–3–60	414	506	16.7	114	16.7	114	277	0.9	STD	83.6%	6.4
										MED	89.5%	8.6
										HIGH	91.7%	14.3
	575–3–60	518	633	12.2	80	12.2	80	397	0.6	STD	83.6%	6.2
										MED	89.5%	7.6
										HIGH	91.7%	9.5
300/303	208–3–60	187	253	48.1	245	33.3	239	350	1.5	STD	83.6%	13.6
										MED	89.5%	17.1
										HIGH	91.7%	28.5
	230–3–60	187	253	48.1	245	33.3	239	350	1.5	STD	83.6%	12.7
										MED	89.5%	17.1
										HIGH	91.7%	28.5
	460–3–60	414	506	18.6	125	17.9	125	277	0.9	STD	83.6%	6.4
										MED	89.5%	8.6
										HIGH	91.7%	14.3
	575–3–60	518	633	14.7	100	12.8	80	397	0.6	STD	83.6%	6.2
										MED	89.5%	7.6
										HIGH	91.7%	9.5

ELECTRICAL INFORMATION

(UNITS PRODUCED PRIOR TO JULY 30, 2012) cont.

TABLE 36 – RAH180/183

ELECTRIC HEAT – ELECTRICAL DATA 2-STAGE COOLING SINGLE SPEED INDOOR FAN MOTOR

NOM. V–Ph–Hz	IFM TYPE	ELECTRIC HEATER PART NUMBER CRHEATER	NOM. PWR (kW)	APP PWR (kW)	SINGLE POINT KIT PART NUMBER CRSINGLE	
					NO C.O. or Unpowered C.O.	
					NO PE.	w/ PE. (pwrd fr/unit)
208/ 230–3–60	STD	279/270A00	25.0	18.8/23.0	–	–
		280/271A00	50.0	37.6/45.9	056A00	056A00
		281/272A00	75.0	56.3/68.9	056A00	056A00
	MED	279/270A00	25.0	18.8/23.0	–	–
		280/271A00	50.0	37.6/45.9	056A00	056A00
		281/272A00	75.0	56.3/68.9	056A00	056A00
	HIGH	279/270A00	25.0	18.8/23.0	–	–
		280/271A00	50.0	37.6/45.9	056A00	056A00
		281/272A00	75.0	56.3/68.9	056A00	056A00
460–3–60	STD	282/273A00	25.0	23.0	–	–
		283/274A00	50.0	45.9	–	057A00
		284/275A00	75.0	68.9	057A00	057A00
	MED	282/273A00	25.0	23.0	–	–
		283/274A00	50.0	45.9	057A00	057A00
		284/275A00	75.0	68.9	057A00	057A00
	HIGH	282/273A00	25.0	23.0	–	–
		283/274A00	50.0	45.9	057A00	057A00
		284/275A00	75.0	68.9	057A00	057A00
575–3–60	STD	285/276A00	24.8	22.8	–	–
		286/277A00	49.6	45.6	–	–
		287/278A00	74.4	68.3	057A00	057A00
	MED	285/276A00	24.8	22.8	–	–
		286/277A00	49.6	45.6	–	–
		287/278A00	74.4	68.3	057A00	057A00
	HIGH	285/276A00	24.8	22.8	–	–
		286/277A00	49.6	45.6	–	057A00
		287/278A00	74.4	68.3	057A00	057A00

LEGEND

APP PWR – 208 / 230V / 460V / 575V
 C.O. – Convenient outlet
 FLA – Full load amps
 IFM – Indoor fan motor

NOM PWR – 240V / 480V / 600V
 PE. – Power exhaust
 UNPWRD – Unpowered convenient outlet

ELECTRICAL INFORMATION

(UNITS PRODUCED PRIOR TO JULY 30, 2012) cont.

TABLE 37 – RAH180/183

ELECTRIC HEAT – ELECTRICAL DATA 2-STAGE COOLING 2-SPEED INDOOR FAN MOTOR

NOM. V–Ph–Hz	IFM TYPE	ELECTRIC HEATER PART NUMBER CRHEATER	NOM PWR (kW)	APP PWR (kW)	SINGLE POINT KIT PART NUMBER CRSINGLE	
					NO C.O. or Unpowered C.O.	
					NO PE.	w/ PE. (pwrd fr/unit)
208/ 230–3–60	STD	279/270A00	25.0	18.8/23.0	–	–
		280/271A00	50.0	37.6/45.9	056A00	056A00
		281/272A00	75.0	56.3/68.9	056A00	056A00
	MED	279/270A00	25.0	18.8/23.0	–	–
		280/271A00	50.0	37.6/45.9	056A00	056A00
		281/272A00	75.0	56.3/68.9	056A00	056A00
	HIGH	279/270A00	25.0	18.8/23.0	–	–
		280/271A00	50.0	37.6/45.9	056A00	056A00
		281/272A00	75.0	56.3/68.9	056A00	056A00
460–3–60	STD	282/273A00	25.0	23.0	–	–
		283/274A00	50.0	45.9	–	057A00
		284/275A00	75.0	68.9	057A00	057A00
	MED	282/273A00	25.0	23.0	–	–
		283/274A00	50.0	45.9	057A00	057A00
		284/275A00	75.0	68.9	057A00	057A00
	HIGH	282/273A00	25.0	23.0	–	–
		283/274A00	50.0	45.9	057A00	057A00
		284/275A00	75.0	68.9	057A00	057A00
575–3–60	STD	285/276A00	24.8	22.8	–	–
		286/277A00	49.6	45.6	–	057A00
		287/278A00	74.4	68.3	057A00	057A00
	MED	285/276A00	24.8	22.8	–	–
		286/277A00	49.6	45.6	–	057A00
		287/278A00	74.4	68.3	057A00	057A00
	HIGH	285/276A00	24.8	22.8	–	–
		286/277A00	49.6	45.6	–	057A00
		287/278A00	74.4	68.3	057A00	057A00

LEGEND

APP PWR – 208 / 230V / 460V / 575V
 C.O. – Convenient outlet
 FLA – Full load amps
 IFM – Indoor fan motor

NOM PWR – 240V / 480V / 600V
 PE. – Power exhaust
 UNPWRD – Unpowered convenient outlet

ELECTRICAL INFORMATION

(UNITS PRODUCED PRIOR TO JULY 30, 2012) cont.

TABLE 38 – RAH210/213

ELECTRIC HEAT – ELECTRICAL DATA 2-STAGE COOLING SINGLE SPEED INDOOR FAN MOTOR

NOM. V–Ph–Hz	IFM TYPE	ELECTRIC HEATER PART NUMBER CRHEATER	NOM. PWR (kW)	APP PWR (kW)	SINGLE POINT KIT PART NUMBER CRSINGLE	
					NO C.O. or Unpowered C.O.	
					NO P.E.	w/ P.E. (pwr fr/unit)
208/ 230–3–60	STD	279/270A00	25.0	18.8/23.0	–	–
		280/271A00	50.0	37.6/45.9	056A00	056A00
		281/272A00	75.0	56.3/68.9	056A00	056A00
	MED	279/270A00	25.0	18.8/23.0	–	–
		280/271A00	50.0	37.6/45.9	056A00	056A00
		281/272A00	75.0	56.3/68.9	056A00	056A00
	HIGH	279/270A00	25.0	18.8/23.0	–	–
		280/271A00	50.0	37.6/45.9	056A00	056A00
		281/272A00	75.0	56.3/68.9	056A00	056A00
460–3–60	STD	282/273A00	25.0	23.0	–	–
		283/274A00	50.0	45.9	057A00	057A00
		284/275A00	75.0	68.9	057A00	057A00
	MED	282/273A00	25.0	23.0	–	–
		283/274A00	50.0	45.9	057A00	057A00
		284/275A00	75.0	68.9	057A00	057A00
	HIGH	282/273A00	25.0	23.0	–	–
		283/274A00	50.0	45.9	057A00	057A00
		284/275A00	75.0	68.9	057A00	057A00
575–3–60	STD	285/276A00	24.8	22.8	–	–
		286/277A00	49.6	45.6	–	–
		287/278A00	74.4	68.3	057A00	057A00
	MED	285/276A00	24.8	22.8	–	–
		286/277A00	49.6	45.6	–	057A00
		287/278A00	74.4	68.3	057A00	057A00
	HIGH	285/276A00	24.8	22.8	–	–
		286/277A00	49.6	45.6	–	057A00
		287/278A00	74.4	68.3	057A00	057A00

LEGEND

APP PWR – 208 / 230V / 460V / 575V
 C.O. – Convenient outlet
 FLA – Full load amps
 IFM – Indoor fan motor

NOM PWR – 240V / 480V / 600V
 P.E. – Power exhaust
 UNPWRD – Unpowered convenient outlet

ELECTRICAL INFORMATION

(UNITS PRODUCED PRIOR TO JULY 30, 2012) cont.

TABLE 39 – RAH210/213

ELECTRIC HEAT – ELECTRICAL DATA 2-STAGE COOLING 2-SPEED INDOOR FAN MOTOR

NOM. V–Ph–Hz	IFM TYPE	ELECTRIC HEATER PART NUMBER CRHEATER	NOM PWR (kW)	APP PWR (kW)	SINGLE POINT KIT PART NUMBER CRSINGLE	
					NO C.O. or Unpowered C.O.	
					NO P.E.	w/ P.E. (pwrd fr/unit)
208/ 230–3–60	STD	279/270A00	25.0	18.8/23.0	–	–
		280/271A00	50.0	37.6/45.9	056A00	056A00
		281/272A00	75.0	56.3/68.9	056A00	056A00
	MED	279/270A00	25.0	18.8/23.0	–	–
		280/271A00	50.0	37.6/45.9	056A00	056A00
		281/272A00	75.0	56.3/68.9	056A00	056A00
	HIGH	279/270A00	25.0	18.8/23.0	–	–
		280/271A00	50.0	37.6/45.9	056A00	056A00
		281/272A00	75.0	56.3/68.9	056A00	056A00
460–3–60	STD	282/273A00	25.0	23.0	–	–
		283/274A00	50.0	45.9	057A00	057A00
		284/275A00	75.0	68.9	057A00	057A00
	MED	282/273A00	25.0	23.0	–	–
		283/274A00	50.0	45.9	057A00	057A00
		284/275A00	75.0	68.9	057A00	057A00
	HIGH	282/273A00	25.0	23.0	–	–
		283/274A00	50.0	45.9	057A00	057A00
		284/275A00	75.0	68.9	057A00	057A00
575–3–60	STD	285/276A00	24.8	22.8	–	–
		286/277A00	49.6	45.6	–	057A00
		287/278A00	74.4	68.3	057A00	057A00
	MED	285/276A00	24.8	22.8	–	–
		286/277A00	49.6	45.6	–	057A00
		287/278A00	74.4	68.3	057A00	057A00
	HIGH	285/276A00	24.8	22.8	–	–
		286/277A00	49.6	45.6	–	057A00
		287/278A00	74.4	68.3	057A00	057A00

LEGEND

APP PWR – 208 / 230V / 460V / 575V
 C.O. – Convenient outlet
 FLA – Full load amps
 IFM – Indoor fan motor

NOM PWR – 240V / 480V / 600V
 P.E. – Power exhaust
 UNPWRD – Unpowered convenient outlet

ELECTRICAL INFORMATION

(UNITS PRODUCED PRIOR TO JULY 30, 2012) cont.

TABLE 40 – RAH240/243

ELECTRIC HEAT – ELECTRICAL DATA 2-STAGE COOLING SINGLE SPEED INDOOR FAN MOTOR

NOM. V–Ph–Hz	IFM TYPE	ELECTRIC HEATER PART NUMBER CRHEATER	NOM. PWR (kW)	APP PWR (kW)	SINGLE POINT KIT PART NUMBER CRSINGLE	
					NO C.O. or Unpowered C.O.	
					NO P.E.	w/ P.E. (pwrd fr/unit)
208/ 203–3–60	STD	279/270A00	25.0	18.8/23.0	–	–
		280/271A00	50.0	37.6/45.9	056A00	056A00
		281/272A00	75.0	56.3/68.9	056A00	056A00
	MED	279/270A00	25.0	18.8/23.0	–	–
		280/271A00	50.0	37.6/45.9	056A00	056A00
		281/272A00	75.0	56.3/68.9	056A00	056A00
	HIGH	279/270A00	25.0	18.8/23.0	–	056A00
		280/271A00	50.0	37.6/45.9	056A00	056A00
		281/272A00	75.0	56.3/68.9	056A00	056A00
460–3–60	STD	282/273A00	25.0	23.0	–	–
		283/274A00	50.0	45.9	057A00	057A00
		284/275A00	75.0	68.9	057A00	057A00
	MED	282/273A00	25.0	23.0	–	–
		283/274A00	50.0	45.9	057A00	057A00
		284/275A00	75.0	68.9	057A00	057A00
	HIGH	282/273A00	25.0	23.0	–	–
		283/274A00	50.0	45.9	057A00	057A00
		284/275A00	75.0	68.9	057A00	057A00
575–3–60	STD	285/276A00	24.8	22.8	–	–
		286/277A00	49.6	45.6	–	057A00
		287/278A00	74.4	68.3	057A00	057A00
	MED	285/276A00	24.8	22.8	–	–
		286/277A00	49.6	45.6	–	057A00
		287/278A00	74.4	68.3	057A00	057A00
	HIGH	285/276A00	24.8	22.8	–	–
		286/277A00	49.6	45.6	057A00	057A00
		287/278A00	74.4	68.3	057A00	057A00

LEGEND

APP PWR – 208 / 230V / 460V / 575V
 C.O. – Convenient outlet
 FLA – Full load amps
 IFM – Indoor fan motor

NOM PWR – 240V / 480V / 600V
 P.E. – Power exhaust
 UNPWRD – Unpowered convenient outlet

ELECTRICAL INFORMATION

(UNITS PRODUCED PRIOR TO JULY 30, 2012) cont.

TABLE 41 – RAH240/243

ELECTRIC HEAT – ELECTRICAL DATA 2-STAGE COOLING 2-SPEED INDOOR FAN MOTOR

NOM. V–Ph–Hz	IFM TYPE	ELECTRIC HEATER PART NUMBER CRHEATER	NOM PWR (kW)	APP PWR (kW)	SINGLE POINT KIT PART NUMBER CRSINGLE	
					NO C.O. Or Unpowered C.O.	
					NO PE.	w/ PE. (pwrd fr/unit)
208/ 203–3–60	STD	279/270A00	25.0	18.8/23.0	–	–
		280/271A00	50.0	37.6/45.9	056A00	056A00
		281/272A00	75.0	56.3/68.9	056A00	056A00
	MED	279/270A00	25.0	18.8/23.0	–	–
		280/271A00	50.0	37.6/45.9	056A00	056A00
		281/272A00	75.0	56.3/68.9	056A00	056A00
	HIGH	279/270A00	25.0	18.8/23.0	–	056A00
		280/271A00	50.0	37.6/45.9	056A00	056A00
		281/272A00	75.0	56.3/68.9	056A00	056A00
460–3–60	STD	282/273A00	25.0	23.0	–	–
		283/274A00	50.0	45.9	057A00	057A00
		284/275A00	75.0	68.9	057A00	057A00
	MED	282/273A00	25.0	23.0	–	–
		283/274A00	50.0	45.9	057A00	057A00
		284/275A00	75.0	68.9	057A00	057A00
	HIGH	282/273A00	25.0	23.0	–	–
		283/274A00	50.0	45.9	057A00	057A00
		284/275A00	75.0	68.9	057A00	057A00
575–3–60	STD	285/276A00	24.8	22.8	–	–
		286/277A00	49.6	45.6	–	057A00
		287/278A00	74.4	68.3	057A00	057A00
	MED	285/276A00	24.8	22.8	–	–
		286/277A00	49.6	45.6	–	057A00
		287/278A00	74.4	68.3	057A00	057A00
	HIGH	285/276A00	24.8	22.8	–	–
		286/277A00	49.6	45.6	057A00	057A00
		287/278A00	74.4	68.3	057A00	057A00

LEGEND

APP PWR – 208 / 230V / 460V / 575V
 C.O. – Convenient outlet
 FLA – Full load amps
 IFM – Indoor fan motor

NOM PWR – 240V / 480V / 600V
 P.E. – Power exhaust
 UNPWRD – Unpowered convenient outlet

ELECTRICAL INFORMATION

(UNITS PRODUCED PRIOR TO JULY 30, 2012) cont.

TABLE 42 – RAH300/303

ELECTRIC HEAT – ELECTRICAL DATA 2-STAGE COOLING SINGLE SPEED INDOOR FAN MOTOR

NOM. V–Ph–Hz	IFM TYPE	ELECTRIC HEATER PART NUMBER CRHEATER	NOM. PWR (kW)	APP PWR (kW)	SINGLE POINT KIT PART NUMBER CRSINGLE	
					NO C.O. or Unpowered C.O.	
					NO P.E.	w/ P.E. (pwrd fr/unit)
208/ 230–3–60	STD	279/270A00	25.0	18.8/23.0	056A00	056A00
		280/271A00	50.0	37.6/45.9	056A00	056A00
		281/272A00	75.0	56.3/68.9	056A00	056A00
	MED	279/270A00	25.0	18.8/23.0	056A00	056A00
		280/271A00	50.0	37.6/45.9	056A00	056A00
		281/272A00	75.0	56.3/68.9	056A00	056A00
	HIGH	279/270A00	25.0	18.8/23.0	056A00	056A00
		280/271A00	50.0	37.6/45.9	056A00	056A00
		281/272A00	75.0	56.3/68.9	056A00	056A00
460–3–60	STD	282/273A00	25.0	23.0	–	–
		283/274A00	50.0	45.9	057A00	057A00
		284/275A00	75.0	68.9	057A00	057A00
	MED	282/273A00	25.0	23.0	–	–
		283/274A00	50.0	45.9	057A00	057A00
		284/275A00	75.0	68.9	057A00	057A00
	HIGH	282/273A00	25.0	23.0	–	057A00
		283/274A00	50.0	45.9	057A00	057A00
		284/275A00	75.0	68.9	057A00	057A00
575–3–60	STD	285/276A00	24.8	22.8	–	–
		286/277A00	49.6	45.6	–	057A00
		287/278A00	74.4	68.3	057A00	057A00
	MED	285/276A00	24.8	22.8	–	–
		286/277A00	49.6	45.6	–	057A00
		287/278A00	74.4	68.3	057A00	057A00
	HIGH	285/276A00	24.8	22.8	–	–
		286/277A00	49.6	45.6	057A00	057A00
		287/278A00	74.4	68.3	057A00	057A00

LEGEND

APP PWR – 208 / 230V / 460V / 575V
 C.O. – Convenient outlet
 FLA – Full load amps
 IFM – Indoor fan motor

NOM PWR – 240V / 480V / 600V
 P.E. – Power exhaust
 UNPWRD – Unpowered convenient outlet

ELECTRICAL INFORMATION

(UNITS PRODUCED PRIOR TO JULY 30, 2012) cont.

TABLE 43 – RAH300/303

ELECTRIC HEAT – ELECTRICAL DATA 2-STAGE COOLING 2-SPEED INDOOR FAN MOTOR

NOM. V–Ph–Hz	IFM TYPE	ELECTRIC HEATER PART NUMBER CRHEATER	NOM PWR (kW)	APP PWR (kW)	SINGLE POINT KIT PART NUMBER CRSINGLE	
					NO C.O. or Unpowered C.O.	
					NO PE.	w/ PE. (pwrd fr/unit)
208/ 230–3–60	STD	279/270A00	25.0	18.8/23.0	056A00	056A00
		280/271A00	50.0	37.6/45.9	056A00	056A00
		281/272A00	75.0	56.3/68.9	056A00	056A00
	MED	279/270A00	25.0	18.8/23.0	056A00	056A00
		280/271A00	50.0	37.6/45.9	056A00	056A00
		281/272A00	75.0	56.3/68.9	056A00	056A00
	HIGH	279/270A00	25.0	18.8/23.0	056A00	056A00
		280/271A00	50.0	37.6/45.9	056A00	056A00
		281/272A00	75.0	56.3/68.9	056A00	056A00
460–3–60	STD	282/273A00	25.0	23.0	–	–
		283/274A00	50.0	45.9	057A00	057A00
		284/275A00	75.0	68.9	057A00	057A00
	MED	282/273A00	25.0	23.0	–	–
		283/274A00	50.0	45.9	057A00	057A00
		284/275A00	75.0	68.9	057A00	057A00
	HIGH	282/273A00	25.0	23.0	–	057A00
		283/274A00	50.0	45.9	057A00	057A00
		284/275A00	75.0	68.9	057A00	057A00
575–3–60	STD	285/276A00	24.8	22.8	–	–
		286/277A00	49.6	45.6	–	057A00
		287/278A00	74.4	68.3	057A00	057A00
	MED	285/276A00	24.8	22.8	–	–
		286/277A00	49.6	45.6	–	057A00
		287/278A00	74.4	68.3	057A00	057A00
	HIGH	285/276A00	24.8	22.8	–	–
		286/277A00	49.6	45.6	057A00	057A00
		287/278A00	74.4	68.3	057A00	057A00

LEGEND

APP PWR – 208 / 230V / 460V / 575V
 C.O. – Convenient outlet
 FLA – Full load amps
 IFM – Indoor fan motor

NOM PWR – 240V / 480V / 600V
 PE. – Power exhaust
 UNPWRD – Unpowered convenient outlet

ELECTRICAL INFORMATION

(UNITS PRODUCED PRIOR TO JULY 30, 2012) cont.

TABLE 44 – UNIT WIRE/FUSE OR HACR BREAKER SIZING DATA WITH SINGLE SPEED INDOOR FAN MOTOR

UNIT RAH	NOM. V–Ph–Hz	IFM TYPE	ELEC. HTR			NO C.O. or UNPWR C.O.							
			CRHEATER	Nom (kW)	FLA	NO P.E.				w/ P.E. (pwrd fr/unit)			
						MCA	MAX FUSE or HACR BRKR	DISC. SIZE		MCA	MAX FUSE or HACR BRKR	DISC. SIZE	
								FLA	LRA			FLA	LRA
180/183	208/ 230–3–60	STD	NONE	–	–	68.3	90	71	393	80.1	100	85	413
			279A00	18.8/25.0	52.1/60.1	74.5/84.5	90/90	71/78	393/393	89.3/99.3	100/100	85/91	413/413
			280A00	37.6/50.0	104.2/120.3	139.6/129.7	150/150	128/147	393/393	154.4/144.4	175/150	142/161	413/413
		281A00	56.3/75.0	156.4/180.4	165.8/189.8	175/200	188/216	393/393	180.5/204.5	200/225	202/230	413/413	
		MED	NONE	–	–	71.0	90	74	410	82.8	100	88	430
			279A00	18.8/25.0	52.1/60.1	77.9/87.9	90/90	74/81	410/410	92.6/102.6	100/110	88/94	430/430
			280A00	37.6/50.0	104.2/120.3	143.0/133.1	150/150	132/150	410/410	157.8/147.8	175/175	145/164	430/430
		HIGH	281A00	56.3/75.0	156.4/180.4	169.2/193.2	200/225	192/219	410/410	183.9/207.9	200/225	205/233	430/430
			NONE	–	–	75.8	100	80	419	87.6	100	93	439
			279A00	18.8/25.0	52.1/60.1	83.9/93.9	100/100	80/86	419/419	98.6/108.6	100/110	93/100	439/439
		280A00	37.6/50.0	104.2/120.3	149.0/139.1	150/175	137/156	419/419	163.8/153.8	175/175	151/169	439/439	
		281A00	56.3/75.0	156.4/180.4	175.2/199.2	200/225	197/225	419/419	189.9/213.9	200/250	211/238	439/439	
	460–3–60	STD	NONE	–	–	34.9	45	36	234	41.1	50	44	246
			282A00	25.0	30.1	41.9	45	39	234	49.6	50	46	246
			283A00	50.0	60.1	64.4	70	73	234	72.1	80	80	246
		MED	284A00	75.0	90.2	94.5	100	108	234	102.2	110	115	246
			NONE	–	–	36.3	45	38	243	42.5	50	45	255
			282A00	25.0	30.1	43.6	45	40	243	51.4	60	47	255
		HIGH	283A00	50.0	60.1	66.1	80	75	243	73.9	80	82	255
			284A00	75.0	90.2	96.2	100	109	243	104.0	110	116	255
			NONE	–	–	38.9	50	41	247	45.1	50	48	259
		282A00	25.0	30.1	46.9	50	43	247	54.6	60	50	259	
		283A00	50.0	60.1	69.4	80	78	247	77.1	80	85	259	
		284A00	75.0	90.2	99.5	110	112	247	107.2	125	119	259	
	575–3–60	STD	NONE	–	–	26.2	30	27	184	31.0	40	33	192
			285A00	24.8	23.9	33.4	35	31	184	39.4	40	36	192
			286A00	49.6	47.7	63.1	70	58	184	69.1	70	64	192
		MED	287A00	74.4	71.6	75.1	80	86	184	81.1	90	91	192
			NONE	–	–	26.2	30	27	184	31.0	40	33	192
			285A00	24.8	23.9	33.4	35	31	184	39.4	40	36	192
		HIGH	286A00	49.6	47.7	63.1	70	58	184	69.1	70	64	192
			287A00	74.4	71.6	75.1	80	86	184	81.1	90	91	192
			NONE	–	–	29.0	35	31	198	33.8	40	36	206
		285A00	24.8	23.9	36.9	40	34	198	42.9	45	39	206	
		286A00	49.6	47.7	66.6	70	61	198	72.6	80	67	206	
		287A00	74.4	71.6	78.6	90	89	198	84.6	90	94	206	

ELECTRICAL INFORMATION

(UNITS PRODUCED PRIOR TO JULY 30, 2012) cont.

TABLE 44 – UNIT WIRE/FUSE SIZING DATA WITH SINGLE SPEED INDOOR FAN MOTOR (cont)

UNIT RAH	NOM. V–Ph–Hz	IFM TYPE	ELEC. HTR			NO C.O. or UNPWR C.O.							
			CRHEATER	Nom (kW)	FLA	NO P.E.				w/ P.E. (pwr fr/unit)			
						MCA	MAX FUSE or HACR BRKR	DISC. SIZE		MCA	MAX FUSE or HACR BRKR	DISC. SIZE	
								FLA	LRA			FLA	LRA
210/213	208/ 230–3–60	STD	NONE	–	–	75.7	100	79	440	87.5	100	93	460
			279A00	18.8/25.0	52.1/60.1	77.9/87.9	100/100	79/81	440/440	92.6/102.6	100/110	93/94	460/460
			280A00	37.6/50.0	104.2/120.3	143.0/133.1	150/150	132/150	440/440	157.8/147.8	175/175	145/164	460/460
			281A00	56.3/75.0	156.4/180.4	169.2/193.2	200/225	192/219	440/440	183.9/207.9	200/225	205/233	460/460
		MED	NONE	–	–	80.5	100	85	449	92.3	100	98	469
			279A00	18.8/25.0	52.1/60.1	83.9/93.9	100/100	85/86	449/449	98.6/108.6	100/110	98/100	469/469
			280A00	37.6/50.0	104.2/120.3	149.0/139.1	150/175	137/156	449/449	163.8/153.8	175/175	151/169	469/469
			281A00	56.3/75.0	156.4/180.4	175.2/199.2	200/225	197/225	449/449	189.9/213.9	200/250	211/238	469/469
		HIGH	NONE	–	–	82.6	100	87	451	94.4	110	101	471
			279A00	18.8/25.0	52.1/60.1	86.5/96.5	100/100	87/89	451/451	101.3/111.3	110/125	101/102	471/471
			280A00	37.6/50.0	104.2/120.3	151.6/141.7	175/175	139/158	451/451	166.4/156.4	175/175	153/172	471/471
			281A00	56.3/75.0	156.4/180.4	177.8/201.8	200/225	200/227	451/451	192.5/216.5	200/250	213/241	471/471
	460–3–60	STD	NONE	–	–	36.6	45	38	245	42.8	50	46	257
			282A00	25.0	30.1	43.6	45	40	245	51.4	60	47	257
			283A00	50.0	60.1	66.1	80	75	245	73.9	80	82	257
			284A00	75.0	90.2	96.2	100	109	245	104.0	110	116	257
		MED	NONE	–	–	39.2	50	41	249	45.4	50	49	261
			282A00	25.0	30.1	46.9	50	43	249	54.6	60	50	261
			283A00	50.0	60.1	69.4	80	78	249	77.1	80	85	261
			284A00	75.0	90.2	99.5	110	112	249	107.2	125	119	261
		HIGH	NONE	–	–	40.4	50	43	250	46.6	50	50	262
			282A00	25.0	30.1	48.4	50	45	250	56.1	60	52	262
			283A00	50.0	60.1	70.9	80	79	250	78.6	80	86	262
			284A00	75.0	90.2	101.0	110	114	250	108.7	125	121	262
	575–3–60	STD	NONE	–	–	26.2	30	27	186	31.0	40	33	194
			285A00	24.8	23.9	33.4	35	31	186	39.4	40	36	194
			286A00	49.6	47.7	63.1	70	58	186	69.1	70	64	194
			287A00	74.4	71.6	75.1	80	86	186	81.1	90	91	194
MED		NONE	–	–	29.0	35	31	200	33.8	40	36	208	
		285A00	24.8	23.9	36.9	40	34	200	42.9	45	39	208	
		286A00	49.6	47.7	66.6	70	61	200	72.6	80	67	208	
		287A00	74.4	71.6	78.6	90	89	200	84.6	90	94	208	
HIGH		NONE	–	–	31.0	40	33	198	35.8	45	38	206	
		285A00	24.8	23.9	39.4	40	36	198	45.4	50	42	206	
		286A00	49.6	47.7	69.1	70	64	198	75.1	80	69	206	
		287A00	74.4	71.6	81.1	90	91	198	87.1	90	97	206	

ELECTRICAL INFORMATION

(UNITS PRODUCED PRIOR TO JULY 30, 2012) cont.

TABLE 44 – UNIT WIRE/FUSE SIZING DATA WITH SINGLE SPEED INDOOR FAN MOTOR (cont)

UNIT RAH	NOM. V–Ph–Hz	IFM TYPE	ELEC. HTR			NO C.O. or UNPWR C.O.							
			CRHEATER	Nom (kW)	FLA	NO P.E.				w/ P.E. (pwrd fr/unit)			
						MCA	MAX FUSE or HACR BRKR	DISC. SIZE		MCA	MAX FUSE or HACR BRKR	DISC. SIZE	
								FLA	LRA			FLA	LRA
240/243	208/ 230–3–60	STD	NONE	–	–	88.7	100	93	544	100.5	125	107	564
			279A00	18.8/25.0	52.1/60.1	88.7/93.9	100/100	93/93	544/544	100.5/108.6	125/125	107/107	564/564
			280A00	37.6/50.0	104.2/120.3	149.0/139.1	150/175	137/156	544/544	163.8/153.8	175/175	151/169	564/564
		281A00	56.3/75.0	156.4/180.4	175.2/199.2	200/225	197/225	544/544	189.9/213.9	200/250	211/238	564/564	
		MED	NONE	–	–	90.8	100	96	546	102.6	125	109	566
			279A00	18.8/25.0	52.1/60.1	90.8/96.5	100/100	96/96	546/546	102.6/111.3	125/125	109/109	566/566
			280A00	37.6/50.0	104.2/120.3	151.6/141.7	175/175	139/158	546/546	166.4/156.4	175/175	153/172	566/566
		HIGH	281A00	56.3/75.0	156.4/180.4	177.8/201.8	200/225	200/227	546/546	192.5/216.5	200/250	213/241	566/566
			NONE	–	–	102.2	125	109	625	114.0	125	122	645
			279A00	18.8/25.0	52.1/60.1	102.2/110.8	125/125	109/109	625/625	115.5/125.5	125/150	122/122	645/645
		280A00	37.6/50.0	104.2/120.3	165.9/155.9	175/175	153/171	625/625	180.6/170.7	200/175	166/185	645/645	
			281A00	56.3/75.0	156.4/180.4	192.0/216.0	200/250	213/240	625/625	206.8/230.8	225/250	226/254	645/645
	NONE		–	–	48.6	60	51	277	54.8	60	58	289	
	460–3–60	STD	282A00	25.0	30.1	48.6	60	51	277	54.8	60	58	289
			283A00	50.0	60.1	69.4	80	78	277	77.1	80	85	289
			284A00	75.0	90.2	99.5	110	112	277	107.2	125	119	289
			NONE	–	–	49.8	60	52	278	56.0	70	60	290
		MED	282A00	25.0	30.1	49.8	60	52	278	56.1	70	60	290
			283A00	50.0	60.1	70.9	80	79	278	78.6	80	86	290
			284A00	75.0	90.2	101.0	110	114	278	108.7	125	121	290
		HIGH	NONE	–	–	55.5	60	59	318	61.7	70	66	330
			282A00	25.0	30.1	55.5	60	59	318	63.3	70	66	330
			283A00	50.0	60.1	78.0	90	86	318	85.7	90	93	330
			284A00	75.0	90.2	108.1	125	120	318	115.8	125	127	330
		575–3–60	STD	NONE	–	–	35.5	45	37	204	40.3	50	43
	285A00			24.8	23.9	36.9	45	37	204	42.9	50	43	212
	286A00			49.6	47.7	66.6	70	61	204	72.6	80	67	212
	287A00			74.4	71.6	78.6	90	89	204	84.6	90	94	212
	MED		NONE	–	–	37.5	45	40	202	42.3	50	45	210
			285A00	24.8	23.9	39.4	45	40	202	45.4	50	45	210
			286A00	49.6	47.7	69.1	70	64	202	75.1	80	69	210
	HIGH		287A00	74.4	71.6	81.1	90	91	202	87.1	90	97	210
			NONE	–	–	39.4	50	42	229	44.2	50	47	237
			285A00	24.8	23.9	41.8	50	42	229	47.8	50	47	237
			286A00	49.6	47.7	71.5	80	66	229	77.5	80	71	237
	287A00		74.4	71.6	83.5	90	93	229	89.5	100	99	237	

ELECTRICAL INFORMATION

(UNITS PRODUCED PRIOR TO JULY 30, 2012) cont.

TABLE 44 – UNIT WIRE/FUSE SIZING DATA WITH SINGLE SPEED INDOOR FAN MOTOR (cont)

UNIT RAH	NOM. V–Ph–Hz	IFM TYPE	ELEC. HTR			NO C.O. or UNPWR C.O.							
			CRHEATER	Nom (kW)	FLA	NO P.E.				w/ P.E. (pwrdr fr/unit)			
						MCA	MAX FUSE or HACR BRKR	DISC. SIZE		MCA	MAX FUSE or HACR BRKR	DISC. SIZE	
								FLA	LRA			FLA	LRA
300/303	208/ 230–3–60	STD	NONE	–	–	117.4	150	121	584	129.2	175	135	604
			279A00	18.8/25.0	52.1/60.1	117.4/117.4	150/150	121/121	584/584	129.2/129.2	175/175	135/135	604/604
			280A00	37.6/50.0	104.2/120.3	149.0/139.1	150/175	137/156	584/584	163.8/153.8	175/175	151/169	604/604
		281A00	56.3/75.0	156.4/180.4	175.2/199.2	200/225	197/225	584/584	189.9/213.9	200/250	211/238	604/604	
		MED	NONE	–	–	119.5	150	124	586	131.3	175	137	606
			279A00	18.8/25.0	52.1/60.1	119.5/119.5	150/150	124/124	586/586	131.3/131.3	175/175	137/137	606/606
			280A00	37.6/50.0	104.2/120.3	151.6/141.7	175/175	139/158	586/586	166.4/156.4	175/175	153/172	606/606
		281A00	56.3/75.0	156.4/180.4	177.8/201.8	200/225	200/227	586/586	192.5/216.5	200/250	213/241	606/606	
		HIGH	NONE	–	–	130.9	175	137	665	142.7	175	150	685
			279A00	18.8/25.0	52.1/60.1	130.9/130.9	175/175	137/137	665/665	142.7/142.7	175/175	150/150	685/685
			280A00	37.6/50.0	104.2/120.3	165.9/155.9	175/175	153/171	665/665	180.6/170.7	200/175	166/185	685/685
		281A00	56.3/75.0	156.4/180.4	192.0/216.0	200/250	213/240	665/665	206.8/230.8	225/250	226/254	685/685	
	460–3–60	STD	NONE	–	–	54.0	60	57	303	60.2	70	64	315
			282A00	25.0	30.1	54.0	60	57	303	60.2	70	64	315
			283A00	50.0	60.1	69.4	80	78	303	77.1	80	85	315
			284A00	75.0	90.2	99.5	110	112	303	107.2	125	119	315
		MED	NONE	–	–	55.2	60	58	304	61.4	70	65	316
			282A00	25.0	30.1	55.2	60	58	304	61.4	70	65	316
			283A00	50.0	60.1	70.9	80	79	304	78.6	80	86	316
			284A00	75.0	90.2	101.0	110	114	304	108.7	125	121	316
		HIGH	NONE	–	–	60.9	70	65	344	67.1	80	72	356
			282A00	25.0	30.1	60.9	70	65	344	67.1	80	72	356
			283A00	50.0	60.1	78.0	90	86	344	85.7	90	93	356
			284A00	75.0	90.2	108.1	125	120	344	115.8	125	127	356
	575–3–60	STD	NONE	–	–	40.4	50	42	228	45.2	50	48	236
			285A00	24.8	23.9	40.4	50	42	228	45.2	50	48	236
			286A00	49.6	47.7	66.6	70	61	228	72.6	80	67	236
			287A00	74.4	71.6	78.6	90	89	228	84.6	90	94	236
		MED	NONE	–	–	42.4	50	45	226	47.2	60	50	234
			285A00	24.8	23.9	42.4	50	45	226	47.2	60	50	234
			286A00	49.6	47.7	69.1	70	64	226	75.1	80	69	234
		287A00	74.4	71.6	81.1	90	91	226	87.1	90	97	234	
		HIGH	NONE	–	–	44.3	50	47	253	49.1	60	52	261
			285A00	24.8	23.9	44.3	50	47	253	49.1	60	52	261
	286A00		49.6	47.7	71.5	80	66	253	77.5	80	71	261	
	287A00	74.4	71.6	83.5	90	93	253	89.5	100	99	261		

ELECTRICAL INFORMATION

(UNITS PRODUCED PRIOR TO JULY 30, 2012) cont.

TABLE 45 – UNIT WIRE/FUSE SIZING DATA WITH FACTORY INSTALLED 2–SPEED INDOOR FAN OPTION

UNIT RAH	NOM. V–Ph–Hz	IFM TYPE	ELEC. HTR			NO C.O. or UNPWR C.O.							
			CRHEATER	Nom (kW)	FLA	NO P.E.				w/ P.E. (pwrd fr/unit)			
						MCA	MAX FUSE or HACR BRKR	DISC. SIZE		MCA	MAX FUSE or HACR BRKR	DISC. SIZE	
					FLA	LRA			FLA	LRA			
180/183	208/ 230–3–60	STD	NONE	–	–	69.4/68.6	90/90	73/72	390	81.2/80.4	100/100	86/85	410
			279A00	18.8/25.0	52.1/60.1	75.9/84.9	90/90	73/78	390/390	90.6/99.6	100/100	86/92	410/410
			280A00	37.6/50.0	104.2/120.3	141.0/130.1	150/150	130/147	390/390	155.8/144.8	175/150	143/161	410/410
		281A00	56.3/75.0	156.4/180.4	167.2/190.2	200/200	190/216	390/390	181.9/204.9	200/225	203/230	410/410	
		MED	NONE	–	–	71.6/70.6	90/90	75/74	414	83.4/82.4	100/100	89/88	434
			279A00	18.8/25.0	52.1/60.1	78.6/87.4	90/90	75/80	414/414	93.4/102.1	100/110	89/94	434/434
			280A00	37.6/50.0	104.2/120.3	143.8/132.6	150/150	132/150	414/414	158.5/147.3	175/175	146/163	434/434
		281A00	56.3/75.0	156.4/180.4	169.9/192.7	200/225	192/219	414/414	184.7/207.4	200/225	206/232	434/434	
		HIGH	NONE	–	–	74.4/73.5	90/90	78/77	425	86.2/85.3	100/100	92/91	445
			279A00	18.8/25.0	52.1/60.1	82.1/91.0	90/100	78/84	425/425	96.9/105.8	100/110	92/97	445/445
			280A00	37.6/50.0	104.2/120.3	147.3/136.2	150/150	135/153	425/425	162.0/150.9	175/175	149/167	445/445
		281A00	56.3/75.0	156.4/180.4	173.4/196.3	200/225	196/222	425/425	188.2/211.0	200/225	209/236	445/445	
	460–3–60	STD	NONE	–	–	35.3	45	37	233	41.5	50	44	245
			282A00	25.0	30.1	42.4	45	39	233	50.1	60	46	245
			283A00	50.0	60.1	64.9	70	73	233	72.6	80	81	245
			284A00	75.0	90.2	95.0	100	108	233	102.7	110	115	245
		MED	NONE	–	–	36.4	45	38	245	42.6	50	45	257
			282A00	25.0	30.1	43.8	45	40	245	51.5	60	47	257
			283A00	50.0	60.1	66.2	80	75	245	74.0	80	82	257
			284A00	75.0	90.2	96.3	100	109	245	104.1	110	116	257
		HIGH	NONE	–	–	37.9	50	40	250	44.1	50	47	262
			282A00	25.0	30.1	45.6	50	42	250	53.4	60	49	262
			283A00	50.0	60.1	68.1	80	76	250	75.9	80	84	262
			284A00	75.0	90.2	98.2	100	111	250	106.0	125	118	262
	575–3–60	STD	NONE	–	–	27.9	35	29	184	32.7	40	35	192
			285A00	24.8	23.9	35.5	40	33	184	41.5	45	38	192
			286A00	49.6	47.7	65.3	70	60	184	71.3	80	66	192
			287A00	74.4	71.6	77.2	90	88	184	83.2	90	93	192
		MED	NONE	–	–	27.9	35	29	184	32.7	40	35	192
			285A00	24.8	23.9	35.5	40	33	184	41.5	45	38	192
			286A00	49.6	47.7	65.3	70	60	184	71.3	80	66	192
			287A00	74.4	71.6	77.2	90	88	184	83.2	90	93	192
		HIGH	NONE	–	–	29.6	35	31	198	34.4	40	37	206
			285A00	24.8	23.9	37.6	40	35	198	43.6	45	40	206
			286A00	49.6	47.7	67.4	70	62	198	73.4	80	68	206
			287A00	74.4	71.6	79.4	90	89	198	85.4	90	95	206

ELECTRICAL INFORMATION

(UNITS PRODUCED PRIOR TO JULY 30, 2012) cont.

TABLE 45 - UNIT WIRE/FUSE SIZING DATA WITH FACTORY INSTALLED 2-SPEED INDOOR FAN OPTION (cont)

UNIT RAH	NOM. V-Ph-Hz	IFM TYPE	ELEC. HTR			NO C.O. or UNPWR C.O.							
			CRHEATER	Nom (kW)	FLA	NO P.E.			w/ P.E. (pwrd fr/unit)				
						MCA	MAX FUSE or HACR BRKR	DISC. SIZE		MCA	MAX FUSE or HACR BRKR	DISC. SIZE	
								FLA	LRA			FLA	LRA
210/213	208/ 230-3-60	STD	NONE	-	-	76.3/75.3	100/100	80/79	444	88.1/87.1	100/100	93/92	464
			279A00	18.8/25.0	52.1/60.1	78.6/87.4	100/100	80/80	444/444	93.4/102.1	100/110	93/94	464/464
			280A00	37.6/50.0	104.2/120.3	143.8/132.6	150/150	132/150	444/444	158.5/147.3	175/175	146/163	464/464
		281A00	56.3/75.0	156.4/180.4	169.9/192.7	200/225	192/219	444/444	184.7/207.4	200/225	206/232	464/464	
		MED	NONE	-	-	79.1/78.2	100/100	83/82	455	90.9/90.0	100/100	97/96	475
			279A00	18.8/25.0	52.1/60.1	82.1/91.0	100/100	83/84	455/455	96.9/105.8	100/110	97/97	475/475
			280A00	37.6/50.0	104.2/120.3	147.3/136.2	150/150	135/153	455/455	162.0/150.9	175/175	149/167	475/475
		281A00	56.3/75.0	156.4/180.4	173.4/196.3	200/225	196/222	455/455	188.2/211.0	200/225	209/236	475/475	
		HIGH	NONE	-	-	82.6	100	87	451	94.4	110	101	471
			279A00	18.8/25.0	52.1/60.1	86.5/96.5	100/100	87/89	451/451	101.3/111.3	110/125	101/102	471/471
			280A00	37.6/50.0	104.2/120.3	151.6/141.7	175/175	139/158	451/451	166.4/156.4	175/175	153/172	471/471
		281A00	56.3/75.0	156.4/180.4	177.8/201.8	200/225	200/227	451/451	192.5/216.5	200/250	213/241	471/471	
	460-3-60	STD	NONE	-	-	36.7	45	39	247	42.9	50	46	259
			282A00	25.0	30.1	43.8	45	40	247	51.5	60	47	259
			283A00	50.0	60.1	66.2	80	75	247	74.0	80	82	259
			284A00	75.0	90.2	96.3	100	109	247	104.1	110	116	259
		MED	NONE	-	-	38.2	50	40	252	44.4	50	47	264
			282A00	25.0	30.1	45.6	50	42	252	53.4	60	49	264
			283A00	50.0	60.1	68.1	80	76	252	75.9	80	84	264
			284A00	75.0	90.2	98.2	100	111	252	106.0	125	118	264
		HIGH	NONE	-	-	40.4	50	43	250	46.6	50	50	262
			282A00	25.0	30.1	48.4	50	45	250	56.1	60	52	262
			283A00	50.0	60.1	70.9	80	79	250	78.6	80	86	262
			284A00	75.0	90.2	101.0	110	114	250	108.7	125	121	262
	575-3-60	STD	NONE	-	-	27.9	35	29	186	32.7	40	35	194
			285A00	24.8	23.9	35.5	40	33	186	41.5	45	38	194
			286A00	49.6	47.7	65.3	70	60	186	71.3	80	66	194
			287A00	74.4	71.6	77.2	90	88	186	83.2	90	93	194
		MED	NONE	-	-	29.6	35	31	200	34.4	40	37	208
			285A00	24.8	23.9	37.6	40	35	200	43.6	45	40	208
			286A00	49.6	47.7	67.4	70	62	200	73.4	80	68	208
			287A00	74.4	71.6	79.4	90	89	200	85.4	90	95	208
		HIGH	NONE	-	-	31.0	40	33	198	35.8	45	38	206
			285A00	24.8	23.9	39.4	40	36	198	45.4	50	42	206
			286A00	49.6	47.7	69.1	70	64	198	75.1	80	69	206
			287A00	74.4	71.6	81.1	90	91	198	87.1	90	97	206

ELECTRICAL INFORMATION

(UNITS PRODUCED PRIOR TO JULY 30, 2012) cont.

TABLE 45 – UNIT WIRE/FUSE SIZING DATA WITH FACTORY INSTALLED 2–SPEED INDOOR FAN OPTION (cont)

UNIT RAH	NOM. V–Ph–Hz	IFM TYPE	ELEC. HTR			NO C.O. or UNPWR C.O.							
			CRHEATER	Nom (kW)	FLA	NO P.E.			w/ P.E. (pwrd fr/unit)				
						MCA	MAX FUSE or HACR BRKR	DISC. SIZE		MCA	MAX FUSE or HACR BRKR	DISC. SIZE	
								FLA	LRA			FLA	LRA
240/243	208/ 230–3–60	STD	NONE	–	–	87.3/86.4	100/100	92/91	550	99.1/98.2	125/125	105/104	570
			279A00	18.8/25.0	52.1/60.1	87.3/91.0	100/100	92/91	550/550	99.1/105.8	125/125	105/104	570/570
			280A00	37.6/50.0	104.2/120.3	147.3/136.2	150/150	135/153	550/550	162.0/150.9	175/175	149/167	570/570
			281A00	56.3/75.0	156.4/180.4	173.4/196.3	200/225	196/222	550/550	188.2/211.0	200/225	209/236	570/570
		MED	NONE	–	–	90.8	100	96	546	102.6	125	109	566
			279A00	18.8/25.0	52.1/60.1	90.8/96.5	100/100	96/96	546/546	102.6/111.3	125/125	109/109	566/566
			280A00	37.6/50.0	104.2/120.3	151.6/141.7	175/175	139/158	546/546	166.4/156.4	175/175	153/172	566/566
			281A00	56.3/75.0	156.4/180.4	177.8/201.8	200/225	200/227	546/546	192.5/216.5	200/250	213/241	566/566
		HIGH	NONE	–	–	102.2	125	109	625	114.0	125	122	645
			279A00	18.8/25.0	52.1/60.1	102.2/110.8	125/125	109/109	625/625	115.5/125.5	125/150	122/122	645/645
			280A00	37.6/50.0	104.2/120.3	165.9/155.9	175/175	153/171	625/625	180.6/170.7	200/175	166/185	645/645
			281A00	56.3/75.0	156.4/180.4	192.0/216.0	200/250	213/240	625/625	206.8/230.8	225/250	226/254	645/645
	460–3–60	STD	NONE	–	–	47.6	60	50	280	53.8	60	57	292
			282A00	25.0	30.1	47.6	60	50	280	53.8	60	57	292
			283A00	50.0	60.1	68.1	80	76	280	75.9	80	84	292
			284A00	75.0	90.2	98.2	100	111	280	106.0	125	118	292
		MED	NONE	–	–	49.8	60	52	278	56.0	70	60	290
			282A00	25.0	30.1	49.8	60	52	278	56.1	70	60	290
			283A00	50.0	60.1	70.9	80	79	278	78.6	80	86	290
			284A00	75.0	90.2	101.0	110	114	278	108.7	125	121	290
		HIGH	NONE	–	–	55.5	60	59	318	61.7	70	66	330
			282A00	25.0	30.1	55.5	60	59	318	63.3	70	66	330
			283A00	50.0	60.1	78.0	90	86	318	85.7	90	93	330
			284A00	75.0	90.2	108.1	125	120	318	115.8	125	127	330
	575–3–60	STD	NONE	–	–	36.1	45	38	204	40.9	50	43	212
			285A00	24.8	23.9	37.6	45	38	204	43.6	50	43	212
			286A00	49.6	47.7	67.4	70	62	204	73.4	80	68	212
			287A00	74.4	71.6	79.4	90	89	204	85.4	90	95	212
		MED	NONE	–	–	37.5	45	40	202	42.3	50	45	210
			285A00	24.8	23.9	39.4	45	40	202	45.4	50	45	210
			286A00	49.6	47.7	69.1	70	64	202	75.1	80	69	210
			287A00	74.4	71.6	81.1	90	91	202	87.1	90	97	210
		HIGH	NONE	–	–	39.4	50	42	229	44.2	50	47	237
			285A00	24.8	23.9	41.8	50	42	229	47.8	50	47	237
			286A00	49.6	47.7	71.5	80	66	229	77.5	80	71	237
			287A00	74.4	71.6	83.5	90	93	229	89.5	100	99	237

ELECTRICAL INFORMATION

(UNITS PRODUCED PRIOR TO JULY 30, 2012) cont.

TABLE 45 – UNIT WIRE/FUSE SIZING DATA WITH FACTORY INSTALLED 2–SPEED INDOOR FAN OPTION (cont)

UNIT RAH	NOM. V–Ph–Hz	IFM TYPE	ELEC. HTR			NO C.O. or UNPWR C.O.							
			CRHEATER	Nom (kW)	FLA	NO P.E.				w/ P.E. (pwrd fr/unit)			
						MCA	MAX FUSE or HACR BRKR	DISC. SIZE		MCA	MAX FUSE or HACR BRKR	DISC. SIZE	
					FLA	LRA			FLA	LRA			
300/303	208/ 230–3–60	STD	NONE	–	–	116.0/115.1	150/150	120/119	590	127.8/126.9	175/175	133/132	610
			279A00	18.8/25.0	52.1/60.1	116.0/115.1	150/150	120/119	590/590	127.8/126.9	175/175	133/132	610/610
			280A00	37.6/50.0	104.2/120.3	147.3/136.2	150/150	135/153	590/590	162.0/150.9	175/175	149/167	610/610
			281A00	56.3/75.0	156.4/180.4	173.4/196.3	200/225	196/222	590/590	188.2/211.0	200/225	209/236	610/610
		MED	NONE	–	–	119.5	150	124	586	131.3	175	137	606
			279A00	18.8/25.0	52.1/60.1	119.5/119.5	150/150	124/124	586/586	131.3/131.3	175/175	137/137	606/606
			280A00	37.6/50.0	104.2/120.3	151.6/141.7	175/175	139/158	586/586	166.4/156.4	175/175	153/172	606/606
			281A00	56.3/75.0	156.4/180.4	177.8/201.8	200/225	200/227	586/586	192.5/216.5	200/250	213/241	606/606
		HIGH	NONE	–	–	130.9	175	137	665	142.7	175	150	685
			279A00	18.8/25.0	52.1/60.1	130.9/130.9	175/175	137/137	665/665	142.7/142.7	175/175	150/150	685/685
			280A00	37.6/50.0	104.2/120.3	165.9/155.9	175/175	153/171	665/665	180.6/170.7	200/175	166/185	685/685
			281A00	56.3/75.0	156.4/180.4	192.0/216.0	200/250	213/240	665/665	206.8/230.8	225/250	226/254	685/685
	460–3–60	STD	NONE	–	–	53.0	60	56	306	59.2	70	63	318
			282A00	25.0	30.1	53.0	60	56	306	59.2	70	63	318
			283A00	50.0	60.1	68.1	80	76	306	75.9	80	84	318
			284A00	75.0	90.2	98.2	100	111	306	106.0	125	118	318
		MED	NONE	–	–	55.2	60	58	304	61.4	70	65	316
			282A00	25.0	30.1	55.2	60	58	304	61.4	70	65	316
			283A00	50.0	60.1	70.9	80	79	304	78.6	80	86	316
			284A00	75.0	90.2	101.0	110	114	304	108.7	125	121	316
		HIGH	NONE	–	–	60.9	70	65	344	67.1	80	72	356
			282A00	25.0	30.1	60.9	70	65	344	67.1	80	72	356
			283A00	50.0	60.1	78.0	90	86	344	85.7	90	93	356
			284A00	75.0	90.2	108.1	125	120	344	115.8	125	127	356
	575–3–60	STD	NONE	–	–	41.0	50	43	228	45.8	60	48	236
			285A00	24.8	23.9	41.0	50	43	228	45.8	60	48	236
			286A00	49.6	47.7	67.4	70	62	228	73.4	80	68	236
			287A00	74.4	71.6	79.4	90	89	228	85.4	90	95	236
		MED	NONE	–	–	42.4	50	45	226	47.2	60	50	234
			285A00	24.8	23.9	42.4	50	45	226	47.2	60	50	234
			286A00	49.6	47.7	69.1	70	64	226	75.1	80	69	234
			287A00	74.4	71.6	81.1	90	91	226	87.1	90	97	234
		HIGH	NONE	–	–	44.3	50	47	253	49.1	60	52	261
			285A00	24.8	23.9	44.3	50	47	253	49.1	60	52	261
			286A00	49.6	47.7	71.5	80	66	253	77.5	80	71	261
			287A00	74.4	71.6	83.5	90	93	253	89.5	100	99	261

SEQUENCE OF OPERATION

General

The sequence below describes the sequence of operation for an electro-mechanical unit with and without a factory installed "Economizer IV or X". For information regarding a direct digital controller, see the start-up, operations, and troubleshooting manual for the applicable controller.

Units with no Economizer

Cooling — (Single speed indoor fan motor)

When the thermostat calls for cooling, terminals G and Y1 are energized. As a result, the indoor-fan contactor (IFC) and the compressor contactor (C1) are energized, causing the indoor-fan motor (IFM), compressor #1, and outdoor fan to start. If the unit has 2 stages of cooling, the thermostat will additionally energize Y2. The Y2 signal will energize compressor contactor #2 (C2), causing compressor #2 to start. Regardless of the number of stages, the outdoor-fan motor runs continuously while unit is cooling.

Cooling (2-speed indoor fan motor) —

Per ASHRAE 90.1 2010 standard section 6.4.3.10.b, during the first stage of cooling operation the VFD will adjust the fan motor to provide 2/3rd of the total cfm established for the unit. When a call for the second stage of cooling is required, the VFD will allow the total cfm for the unit established (100%).

Heating —

NOTE: This unit is sold as cooling only. If electric heaters are required, use only factory-approved electric heaters. They will operate as described below.

Units have either 1 or 2 stages of electric heat. When the thermostat calls for heating, power is applied to the W1 terminal at the unit. The unit control will energize the indoor fan contactor and the first stage of electric heat. On units with 2-stage heating, when additional heating is required, the second stage of electric heat (if equipped) will be energized when power is applied at the W2 terminal on the unit.

Units with an Economizer

Cooling —

When free cooling is not available, the compressors will be controlled by the zone thermostat. When free cooling is available, the outdoor-air damper is modulated by the Economizer IV or X control to provide a 50°F (10°C) to 55°F (13°C) mixed-air temperature into the zone. As the mixed air temperature fluctuates above 55°F (13°C) or below 50°F (10°C) dampers will be modulated (open or close) to bring the mixed-air temperature back within control. If mechanical cooling is utilized with free cooling, the outdoor-air damper will maintain its current position at the time the compressor is started. If the increase in cooling capacity causes the mixed-air temperature to drop below 45°F (7°C), then the outdoor-air damper position will be decreased to the minimum position. If the mixed-air temperature continues to fall, the outdoor-air damper will close. Control returns to normal once the mixed-air temperature rises above 48°F (9°C). The power exhaust fans will be energized and de-energized, if installed, as the outdoor-air damper opens and closes.

If field-installed accessory CO₂ sensors are connected to the economizer IV or X control, a demand controlled ventilation strategy will begin to operate. As the CO₂ level in the zone increases above the CO₂ setpoint, the minimum position of the damper will be increased proportionally. As the CO₂ level

decreases because of the increase in fresh air, the outdoor-air damper will be proportionally closed. For economizer IV or X operation, there must be a thermostat call for the fan (G). If the unit is occupied and the fan is on, the damper will operate at minimum position. Otherwise, the damper will be closed.

When the economizer IV control is in the occupied mode and a call for cooling exists (Y1 on the thermostat), the control will first check for indoor fan operation. If the fan is not on, then cooling will not be activated. If the fan is on, then the control will open the economizer IV damper to the minimum position.

On the initial power to the economizer IV control, it will take the damper up to 2 1/2 minutes before it begins to position itself. After the initial power-up, further changes in damper position can take up to 30 seconds to initiate. Damper movement from full closed to full open (or vice versa) will take between 1 1/2 and 2 1/2 minutes. If free cooling can be used as determined from the appropriate changeover command (switch, dry bulb, enthalpy curve, differential dry bulb, or differential enthalpy), then the control will modulate the dampers open to maintain the mixed-air temperature setpoint at 50°F (10°C) to 55°F (13°C). If there is a further demand for cooling (cooling second stage – Y2 is energized), then the control will bring on compressor stage 1 to maintain the mixed-air temperature setpoint. The economizer IV damper will be open at maximum position. economizer IV operation is limited to a single compressor.

2-Speed Note: When operating in ventilation mode only, the indoor fan motor will automatically adjust to 2/3rd of the total cfm established.

Heating —

The sequence of operation for the heating is the same as a unit with no economizer. The only difference is how the economizer acts. The economizer will stay at the Economizer Minimum Position while the evaporator fan is operating. The outdoor-air damper is closed when the indoor fan is not operating.

Refer to Service and Maintenance Manual for further details.

Hot Gas Reheat System

Units with the factory equipped Hot Gas Reheat option are capable of providing multiple modes of improved dehumidification as a variation of the normal cooling cycle. The Hot Gas Reheat option includes additional valves in the liquid line and discharge line of each refrigerant circuit, a small reheat condenser coil downstream of the evaporator, and Motormaster variable-speed control of some or all outdoor fans. Operation of the revised refrigerant circuit for each mode is described below.

The Hot Gas Reheat system provides three sub-modes of operation: Cool, Reheat1, and Reheat2.

Cool mode – provides a normal ratio of Sensible and Latent Cooling effect from the evaporator coil.

Reheat1 – provides increased Latent Cooling while slightly reducing the Sensible Cooling effect.

Reheat2 – provides normal Latent Cooling but with null or minimum Sensible Cooling effect delivered to the space.

The Reheat1 and Reheat2 modes are available when the unit is not in a Heating mode and when the Low Ambient Lockout switch is closed.

The following diagrams depict piping for two Stage cooling units.

SEQUENCE OF OPERATION (CONT.)

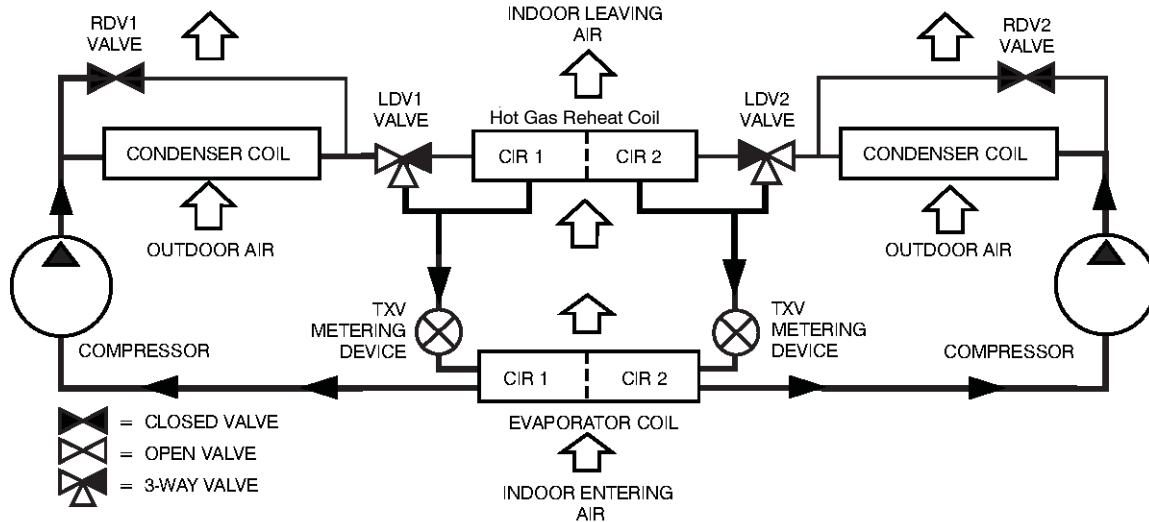

NORMAL COOLING MODE - HOT GAS REHEAT SYSTEM

C12705

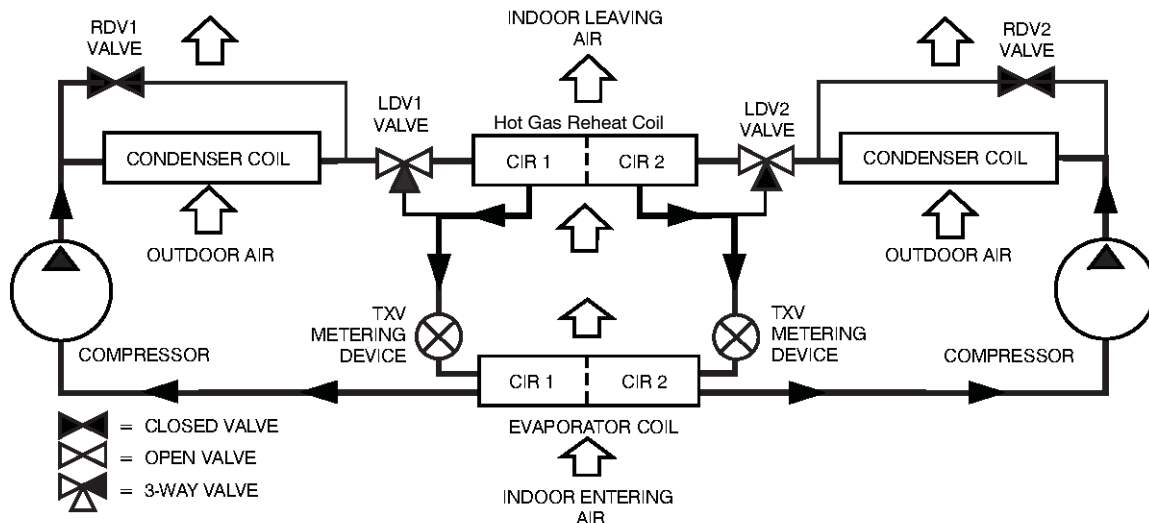

SUBCOOLING MODE (REHEAT 1) - HOT GAS REHEAT SYSTEM

C12706

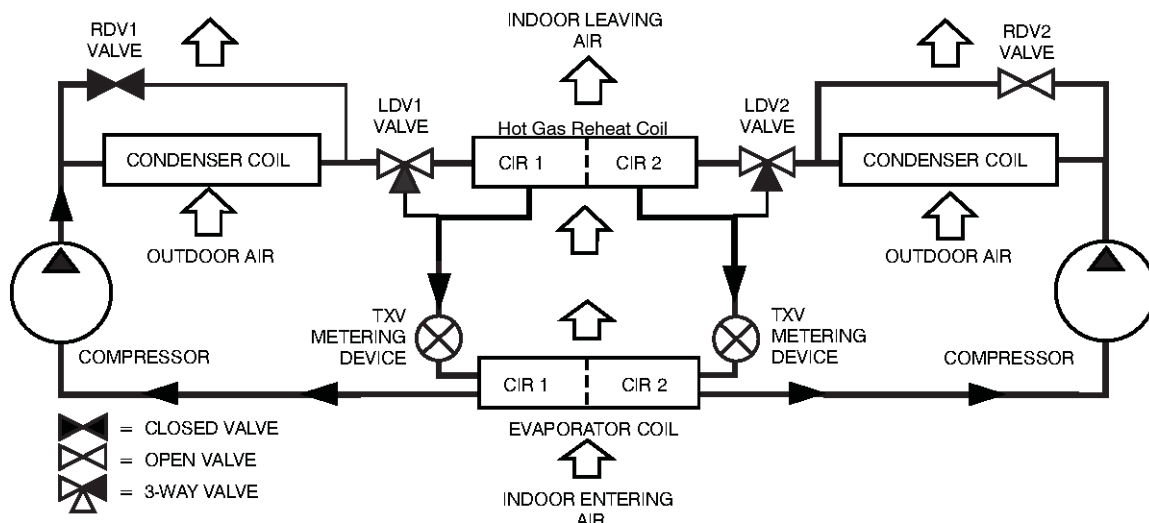

HOT GAS REHEAT (REHEAT 2) - HOT GAS REHEAT SYSTEM

C12707

GUIDE SPECIFICATIONS – RAS210 – 333

Note about this specification:

COOLING ONLY / ELECTRIC HEAT PACKAGED ROOFTOP

HVAC Guide Specifications

Size Range: 17.5 to 27.5 Nominal Tons



<u>Section</u>	<u>Description</u>
----------------	--------------------

23 06 80	Schedules for Decentralized HVAC Equipment
-----------------	---

23 06 80.13	Decentralized Unitary HVAC Equipment Schedule
-------------	---

23 06 80.13.A.	Rooftop unit schedule
----------------	-----------------------

1. Schedule is per the project specification requirements.

23 07 16	HVAC Equipment Insulation
-----------------	----------------------------------

23 07 16.13	Decentralized, Rooftop Units:
-------------	-------------------------------

23 07 16.13.A.	Evaporator fan compartment:
----------------	-----------------------------

1. Interior cabinet surfaces shall be insulated with a minimum 1/2-in. thick, minimum 1 1/2 lb density, flexible fiberglass insulation bonded with a phenolic binder, neoprene coated on the air side.
2. Insulation and adhesive shall meet NFPA 90A requirements for flame spread and smoke generation.

23 07 16.13.B.	Electric heat compartment:
----------------	----------------------------

1. Aluminum foil-faced fiberglass insulation shall be used.
2. Insulation and adhesive shall meet NFPA 90A requirements for flame spread and smoke generation.

23 09 13	Instrumentation and Control Devices for HVAC
-----------------	---

23 09 13.23	Sensors and Transmitters
-------------	--------------------------

23 09 13.23.A.	Thermostats
----------------	-------------

1. Thermostat must
 - a. energize both "W" and "G" when calling for heat.
 - b. have capability to energize 2 different stages of cooling, and 2 different stages of heating.
 - c. include capability for occupancy scheduling.

23 09 33	Electric and Electronic Control System for HVAC
-----------------	--

23 09 33.13	Decentralized, Rooftop Units:
-------------	-------------------------------

23 09 33.13.A.	General:
----------------	----------

1. Shall be complete with self-contained low-voltage control circuit protected by a resettable circuit breaker on the 24-v transformer side. Transformer shall have 75VA capability.
2. Shall utilize color-coded wiring.
3. Shall include a central control terminal board to conveniently and safely provide connection points for vital control functions such as: smoke detectors, phase monitor, economizer, thermostat, and low and high pressure switches.
4. Unit shall include a minimum of one 8-pin screw terminal connection board for connection of control wiring.

23 09 33.23.B.	Safeties:
----------------	-----------

1. Compressor over-temperature, over-current. High internal pressure differential.
2. Low-pressure switch.
 - a. Units shall have different sized connectors for the circuit 1 and circuit 2 low and high pressure switches. They shall physically prevent the cross-wiring of the safety switches between circuits 1 and 2.
 - b. Low pressure switch shall use different color wire than the high pressure switch. The purpose is to assist the installer and service technician to correctly wire and or troubleshoot the rooftop unit.

3. High-pressure switch.
 - a. Units shall have different sized connectors for the circuit 1 and circuit 2 low and high pressure switches. They shall physically prevent the cross-wiring of the safety switches between circuits 1 and 2.
 - b. High pressure switch shall use different color wire than the low pressure switch. The purpose is to assist the installer and service technician to correctly wire and or troubleshoot the rooftop unit.
4. Automatic reset, motor thermal overload protector.

23 09 93 Sequence of Operations for HVAC Controls

23 09 93.13 Decentralized, Rooftop Units:

23 09 93.13 INSERT SEQUENCE OF OPERATION

23 40 13 Panel Air Filters

23 40 13.13 Decentralized, Rooftop Units:

23 40 13.13.A. Standard filter section

1. Shall consist of factory-installed, low velocity, disposable 2-in. thick fiberglass filters of commercially available sizes.
2. Unit shall use only one filter size. Multiple sizes are not acceptable.
3. Filters shall be accessible through a dedicated, weather tight access panel.
4. 4-in filter capabilities shall be capable with pre-engineered and approved filter track field installed accessory. This kit requires field furnished filters.

23 81 19 Self-Contained Air Conditioners

23 81 19.13 Medium-Capacity Self-Contained Air Conditioners (RAS210-303)

23 81 19.13.A. General

1. Outdoor, rooftop mounted, electrically controlled, heating and cooling unit utilizing a fully hermetic scroll compressor(s) for cooling duty and electric heat accessories for heating duty.
2. Factory assembled, single-piece heating and cooling rooftop unit. Contained within the unit enclosure shall be all factory wiring, piping, controls, and special features required prior to field start-up.
3. Unit shall use environmentally sound, R-410A refrigerant.
4. Unit shall be installed in accordance with the manufacturer's instructions.
5. Unit must be selected and installed in compliance with local, state, and federal codes.

23 81 19.13.B. Quality Assurance

1. Unit meets ASHRAE 90.1 minimum efficiency requirements.
2. Units are Energy Star certified where sizes are required.
3. Unit shall be rated in accordance with AHRI Standard 340/360.
4. Unit shall be designed to conform to ASHRAE 15.
5. Unit shall be UL-tested and certified in accordance with ANSI Z21.47 Standards and UL-listed and certified under Canadian standards as a total package for safety requirements.
6. Insulation and adhesive shall meet NFPA 90A requirements for flame spread and smoke generation.
7. Unit casing shall be capable of withstanding 500-hour salt spray exposure per ASTM B117 (scribed specimen).
8. Unit casing shall be capable of withstanding Federal Test Method Standard No. 141 (Method 6061) 5000-hour salt spray.
9. Unit shall be designed in accordance with ISO 9001:2000, and shall be manufactured in a facility registered by ISO 9001:2000.
10. Roof curb shall be designed to conform to NRCA Standards.
11. Unit shall be subjected to a completely automated run test on the assembly line. The data for each unit will be stored at the factory, and must be available upon request.
12. Unit shall be designed in accordance with UL Standard 1995, including tested to withstand rain.
13. Unit shall be constructed to prevent intrusion of snow and tested to prevent snow intrusion into the control box up to 40 mph.
14. Unit shake tested to assurance level 1, ASTM D4169 to ensure shipping reliability.
15. High Efficient Motors listed shall meet section 313 of the Energy Independence and Security Act of 2007 (EISA 2007).

23 81 19.13.C. Delivery, Storage, and Handling

1. Unit shall be stored and handled per manufacturer's recommendations.
2. Lifted by crane requires either shipping top panel or spreader bars.
3. Unit shall only be stored or positioned in the upright position.

23 81 19.13.E. Project Conditions

1. As specified in the contract.

23 81 19.13.F. Operating Characteristics

1. Unit shall be capable of starting and running at 115°F (46°C) ambient outdoor temperature, meeting maximum load criteria of AHRI Standard 340/360 at ± 10% voltage.
2. Compressor with standard controls shall be capable of operation down to 30°F (-1°C), ambient outdoor temperatures. Accessory winter start kit is necessary if mechanically cooling at ambient temperatures below 30°F (-1°C).
3. Unit shall discharge supply air vertically or horizontally as shown on contract drawings.
4. Unit shall be factory configured and ordered for vertical supply & return configurations.
5. Unit shall be factory furnished for either vertical or horizontal configuration without the use of special conversion kits. No field conversion is possible.
6. Unit shall be capable of mixed operation: vertical supply with horizontal return or horizontal supply with vertical return.

23 81 19.13.G. Electrical Requirements

1. Main power supply voltage, phase, and frequency must match those required by the manufacturer.

23 81 19.13.H. Unit Cabinet

1. Unit cabinet shall be constructed of galvanized steel, and shall be bonderized and coated with a pre-painted baked enamel finish on all externally exposed surfaces.
2. Unit cabinet exterior paint shall be: film thickness, (dry) 0.003 inches minimum, gloss (per ASTM D523, 60°F / 16°C): 60, Hardness: H-2H Pencil hardness.
3. Evaporator fan compartment interior cabinet insulation shall conform to AHRI Standard 340/360 minimum exterior sweat criteria. Interior surfaces shall be insulated with a minimum 1/2-in. thick, 1 lb density, flexible fiberglass insulation, neoprene coated on the air side. Aluminum foil-faced fiberglass insulation shall be used in the gas heat compartment.
4. Base of unit shall have a minimum of four locations for thru-the-base electrical connections standard. Electric connections shall be internal to the cabinet to protect from environmental issues.
5. Base Rail
 - a. Unit shall have base rails on a minimum of 2 sides.
 - b. Holes shall be provided in the base rails for rigging shackles to facilitate maneuvering and overhead rigging.
 - c. Holes shall be provided in the base rail for moving the rooftop by fork truck.
 - d. Base rail shall be a minimum of 16 gauge thickness.
6. Condensate pan and connections:
 - a. Shall be a sloped condensate drain pan made of a non-corrosive material.
 - b. Shall comply with ASHRAE Standard 62.
 - c. Shall use a 3/4-in -14 NPT drain connection, through the side of the drain pan. Connection shall be made per manufacturer's recommendations.
7. Top panel:
 - a. Shall be a multi-piece top panel linked with water tight flanges and locking systems.
8. Electrical Connections
 - a. All unit power wiring shall enter unit cabinet at a single, factory-prepared, knockout location.
 - b. Thru-the-base capability.
 - (1.) Standard unit shall have a thru-the-base electrical location(s) using a raised, embossed portion of the unit basepan.
 - (2.) Optional, factory-approved, water-tight connection method must be used for thru-the-base electrical connections.
 - (3.) No basepan penetration, other than those authorized by the manufacturer, is permitted.
9. Component access panels (standard)
 - a. Cabinet panels shall be easily removable for servicing.
 - b. Unit shall have one factory installed, tool-less, removable, filter access panel.
 - c. Panels covering control box and filter shall have molded composite handles while the blower access door shall have an integrated flange for easy removal.
 - d. Handles shall be UV modified, composite. They shall be permanently attached, and recessed into the panel.
 - e. Screws on the vertical portion of all removable access panels shall engage into heat resistant, molded composite collars.

f. Collars shall be removable and easily replaceable using manufacturer recommended parts.

23 81 19.13.J. Coils

1. Standard Aluminum fin – Copper Tube Coils:

- a. Standard evaporator and condenser coils shall have aluminum lanced plate fins mechanically bonded to seamless internally grooved copper tubes with all joints brazed.
- b. Evaporator coils shall be leak tested to 150 psig, pressure tested to 450 psig, and qualified to UL 1995 burst test at 1775 psig.
- c. Condenser coils shall be leak tested to 150 psig, pressure tested to 650 psig, and qualified to UL 1995 burst test at 1980 psig.

2. Optional Pre-coated aluminum–fin condenser coils:

- a. Shall have a durable epoxy–phenolic coating to provide protection in mildly corrosive coastal environments.
- b. Coating shall be applied to the aluminum fin stock prior to the fin stamping process to create an inert barrier between the aluminum fin and copper tube.
- c. Epoxy–phenolic barrier shall minimize galvanic action between dissimilar metals.

3. Optional Copper–fin evaporator and condenser coils:

- a. Shall be constructed of copper fins mechanically bonded to copper tubes and copper tube sheets.
- b. Galvanized steel tube sheets shall not be acceptable.
- c. A polymer strip shall prevent coil assembly from contacting the sheet metal coil pan to minimize potential for galvanic corrosion between coil and pan.

4. Optional E-coated aluminum–fin evaporator and condenser coils:

- a. Shall have a flexible epoxy polymer coating uniformly applied to all coil surface areas without material bridging between fins.
- b. Coating process shall ensure complete coil encapsulation of tubes, fins and headers.
- c. Color shall be high gloss black with gloss per ASTM D523–89.
- d. Uniform dry film thickness from 0.8 to 1.2 mil on all surface areas including fin edges.
- e. Superior hardness characteristics of 2H per ASTM D3363–92A and cross-hatch adhesion of 4B–5B per ASTM D3359–93.
- f. Impact resistance shall be up to 160 in.–lb (ASTM D2794–93).
- g. Humidity and water immersion resistance shall be up to minimum 1000 and 250 hours respectively (ASTM D2247–92 and ASTM D870–92).
- h. Corrosion durability shall be confirmed through testing to be no less than 1000 hours salt spray per ASTM B117–90.

5. Optional E-coated aluminum–fin, aluminum tube condenser coils:

- a. Shall have a flexible epoxy polymer coating uniformly applied to all coil external surface areas without material bridging between fins or louvers.
- b. Coating process shall ensure complete coil encapsulation, including all exposed fin edges.
- c. E-coat thickness of 0.8 to 1.2 mil with top coat having a uniform dry film thickness from 1.0 to 2.0 mil on all external coil surface areas, including fin edges, shall be provided.
- d. Shall have superior hardness characteristics of 2H per ASTM D3363–00 and cross-hatch adhesion of 4B–5B per ASTM D3359–02.
- e. Shall have superior impact resistance with no cracking, chipping or peeling per NSF/ANSI 51–2002 Method 10.2.

23 81 19.13.K. Refrigerant Components

1. Refrigerant circuit shall include the following control, safety, and maintenance features:

- a. Fixed orifice metering system shall prevent mal-distribution of two-phase refrigerant by including multiple fixed orifice devices in each refrigeration circuit. Each orifice is to be optimized to the coil circuit it serves.
- b. Refrigerant filter drier – Solid core design.
- c. Service gauge connections on suction and discharge lines.
- d. Pressure gauge access through a specially designed access screen on the side of the unit.

2. Compressors

- a. Unit shall use fully hermetic, scroll compressor for each independent refrigeration circuit.
- b. Models shall be available with 2 compressor/2 stage cooling and microchannel condenser coils.
- c. Compressor motors shall be cooled by refrigerant gas passing through motor windings.
- d. Compressors shall be internally protected from high discharge temperature conditions.

- e. Compressors shall be protected from an over-temperature and over-ampereage conditions by an internal, motor overload device.
- f. Compressor shall be factory mounted on rubber grommets.
- g. Compressor motors shall have internal line break thermal, current overload and high pressure differential protection.
- h. Crankcase heaters shall not be required for normal operating range, unless provided by the factory.

23 81 19.13.L. Filter Section

- 1. Filters access is specified in the unit cabinet section of this specification.
- 2. Filters shall be held in place by a preformed, slide-out filter tray, facilitating easy removal and installation.
- 3. Shall consist of factory-installed, low velocity, throw-away 2-in. thick fiberglass filters.
- 4. Filters shall be standard, commercially available sizes.
- 5. Only one size filter per unit is allowed.
- 6. 4-in filter capability is possible with a field installed pre engineered slide out filter track accessory. 4-in filters are field furnished.

23 81 19.13.M. Evaporator Fan and Motor

- 1. Evaporator fan motor:
 - a. Shall have inherent automatic-reset thermal overload protection or circuit breaker.
 - b. Shall have a maximum continuous bhp rating for continuous duty operation; no safety factors above that rating shall be required.
- 2. Belt-driven Evaporator Fan:
 - a. Belt drive shall include an adjustable-pitch motor pulley and belt break protection system.
 - b. Shall use rigid pillow block bearing system with lubricant fittings at accessible bearing or lubrication line.
 - c. Blower fan shall be double-inlet type with forward-curved blades.
 - d. Shall be constructed from steel with a corrosion resistant finish and dynamically balanced.

23 81 19.13.N. Condenser Fans and Motors

- 1. Condenser fan motors:
 - a. Shall be a totally enclosed motor.
 - b. Shall use permanently lubricated bearings.
 - c. Shall have inherent thermal overload protection with an automatic reset feature.
 - d. Shall use a shaft-down design.
- 2. Condenser Fans:
 - a. Shall be a direct-driven propeller type fan.
 - b. Shall have aluminum blades riveted to corrosion-resistant steel spiders and shall be dynamically balanced.

23 81 19.13.O. Special Features Options and Accessories

- 1. 2-speed indoor fan motor for 2-stage cooling models only
 - a. Evaporator fan motor:
 - (1.) Shall have permanently lubricated bearings.
 - (2.) Shall have a maximum continuous bhp rating for continuous duty operation; no safety factors above that rating.
 - (3.) Shall be Variable Frequency duty and 2-speed control.
 - (4.) Shall contain motor shaft grounding ring to prevent electrical bearing fluting damage by safely diverting harmful shaft voltages and bearing currents to ground.
- 2. Variable Frequency Drive (VFD). Only available on 2-speed indoor fan motor option:
 - a. Shall be installed inside the unit cabinet, mounted, wired and tested.
 - b. Shall contain Electromagnetic Interference (EMI) frequency protection.
 - c. Insulated Gate Bi-Polar Transistors (IGBT) used to produce the output pulse width modulated (PWM) waveform, allowing for quiet motor operation.
 - d. Self diagnostics with fault and power code LED indicator. Field accessory Display Kit available for further diagnostics and special setup applications.
 - e. RS485 capability standard.
 - f. Electronic thermal overload protection.
 - g. 5% swinging chokes for harmonic reduction and improved power factor.
 - h. All printed circuit boards shall be conformal coated.

3. Standard Integrated Economizers (Factory installed on 3 Phase Models Only. Field installed on all 3 and 1 Phase Models):
 - a. Integrated, gear-driven opposing blade design type capable of simultaneous economizer and compressor operation.
 - b. Independent modules for vertical or horizontal return configurations shall be available. Vertical and horizontal return modules shall be available as a factory installed option.
 - c. Damper blades shall be galvanized steel with composite gears. Plastic or composite blades on intake or return shall not be acceptable.
 - d. Shall include all hardware and controls to provide free cooling with outdoor air when temperature and/or humidity are below setpoints.
 - e. Shall be equipped with gear driven dampers for both the outdoor ventilation air and the return air for positive air stream control.
 - f. Standard models shall be equipped with low-leakage dampers, not to exceed 2% leakage at 1 in. wg pressure differential. Economizer controller on electromechanical units shall be Honeywell W7212 that provides:
 - (1.) Combined minimum and DCV maximum damper position potentiometers with compressor staging relay.
 - (2.) Functions with solid state analog enthalpy or dry bulb changeover control sensing.
 - (3.) Contain LED indicates for:
 - When free cooling is available
 - When module is in DCV mode
 - When exhaust fan contact is closed
 - g. Ultra low leak EconoMi\$er X system shall be available on models with 2-speed indoor fan motor 2-speed Variable Frequency Drive (VFD) systems. Only available on 2-Speed Indoor Fan Motor Systems with electromechanical controls or RTU Open.
 - (1.) Maximum damper leakage rate to be equal to or less than 4.0 cfm/sq. ft. at 1.0 in. w.g., meeting or exceeding ASHRAE 90.1 requirements. Economizer controller on electromechanical units shall be Honeywell W7220 that provides:
 - (2.) 2-line LCD interface screen for setup, configuration and troubleshooting.
 - (3.) On-board fault detection and diagnostics
 - (4.) Sensor failure loss of communication identification
 - (5.) Automatic sensor detection
 - (6.) Capabilities for use with multiple-speed indoor fan systems
 - (7.) Utilize digital sensors: Dry bulb and Enthalpy
 - h. Shall be capable of introducing up to 100% outdoor air.
 - i. Shall be equipped with a barometric relief damper capable of relieving up to 100% return air.
 - j. Shall be designed to close damper(s) during loss-of-power situations with spring return built into motor.
 - k. Dry bulb outdoor air temperature sensor shall be provided as standard. Outdoor air sensor setpoint shall be adjustable and shall range from 40 to 100°F / 4 to 38°C. Additional sensor options shall be available as accessories.
 - l. The economizer controller shall also provide control of an accessory power exhaust unit function. Factory set at 100%, with a range of 0% to 100%.
 - m. The economizer shall maintain minimum airflow into the building during occupied period and provide design ventilation rate for full occupancy. A remote potentiometer may be used to override the damper setpoint.
 - n. Dampers shall be completely closed when the unit is in the unoccupied mode.
 - o. Economizer controller shall accept a 2-10 Vdc CO₂ sensor input for IAQ/DCV control. In this mode, dampers shall modulate the outdoor air damper to provide ventilation based on the sensor input.
 - p. Compressor lockout sensor shall open at 35°F (2°C) and close closes at 50°F (10°C).
 - q. Actuator shall be direct coupled to economizer gear. No linkage arms or control rods shall be acceptable.
 - r. Economizer controller shall provide indications when in free cooling mode, in the DCV mode, or the exhaust fan contact is closed.
4. Two-Position Motorized Damper (Factory installed on 3 Phase Models Only. Field installed on all 3 and 1 Phase Models)
 - a. Damper shall be a Two-Position Damper. Damper travel shall be from the full closed position to the field adjustable %-open setpoint.
 - b. Damper shall include adjustable damper travel from 25% to 100% (full open).
 - c. Damper shall include single or dual blade, gear driven dampers and actuator motor.
 - d. Actuator shall be direct coupled to damper gear. No linkage arms or control rods shall be acceptable.

- e. Damper will admit up to 100% outdoor air for applicable rooftop units.
 - f. Damper shall close upon indoor (evaporator) fan shutoff and/or loss of power.
 - g. The damper actuator shall plug into the rooftop unit's wiring harness plug. No hard wiring shall be required.
 - h. Outside air hood shall include aluminum water entrainment filter
5. Manual damper
- a. Manual damper package shall consist of damper, air inlet screen, and rain hood which can be preset to admit up to 25% outdoor air for year round ventilation.
6. Hot Gas Reheat System (3 Phase Models only)
- a. The Hot Gas Reheat System shall be factory-installed in 2-stage RAS models with RTPF (round tube plate fin) condenser coils, and shall provide greater dehumidification of the occupied space by two modes of dehumidification operations beside its normal design cooling mode:
 - (1.) Subcooling mode further subcools the hot liquid refrigerant leaving the condenser coil when both temperature and humidity in the space are not satisfied.
 - (2.) Hot gas reheat mode shall mix a portion of the hot gas from the discharge of the compressor with the hot liquid refrigerant leaving the condenser coil to create a two-phase heat transfer in the system, resulting in a neutral leaving-air temperature when only humidity in the space is not satisfied.
 - (3.) Includes Head Pressure Controller.
7. Head Pressure Control Package
- a. Controller shall control coil head pressure by condenser-fan speed modulation or condenser-fan cycling and wind baffles.
 - b. Shall consist of solid-state control and condenser-coil temperature sensor to maintain condensing temperature between 90°F (32°C) and 110°F (43°C) at outdoor ambient temperatures down to -20°F (-29°C).
8. Condenser Coil Hail Guard Assembly
- a. Shall protect against damage from hail.
 - b. Shall be louvered style design.
9. Unit-Mounted, Non-Fused Disconnect Switch:
- a. Switch shall be factory-installed, internally mounted.
 - b. National Electric Code (NEC) and ETL approved non-fused switch shall provide unit power shutoff.
 - c. Shall be accessible from outside the unit
 - d. Shall provide local shutdown and lockout capability.
10. Convenience Outlet:
- a. Non-Powered convenience outlet.
 - (1.) Outlet shall be powered from a separate 115/120v power source.
 - (2.) A transformer shall not be included.
 - (3.) Outlet shall be factory-installed and internally mounted with easily accessible 115-v female receptacle.
 - (4.) Outlet shall include 15 amp GFI receptacles with independent fuse protection.
 - (5.) Outlet shall be accessible from outside the unit.
 - (6.) Outlet shall include a field-installed "Wet in Use" cover.
11. Fan/Filter Status Switch:
- a. Switch shall provide status of indoor evaporator fan (ON/OFF) or filter (CLEAN/DIRTY).
 - b. Status shall be displayed either over communication bus (when used with direct digital controls) or with an indicator light at the thermostat.
12. Centrifugal Power Exhaust:
- a. Power exhaust shall be used in conjunction with an integrated economizer.
 - b. Independent modules for vertical or horizontal return configurations shall be available.
 - c. Horizontal power exhaust is shall be mounted in return ductwork.
 - d. Power exhaust shall be controlled by economizer controller operation. Exhaust fans shall be energized when dampers open past the 0-100% adjustable setpoint on the economizer control.
13. Roof Curbs (Vertical):
- a. Full perimeter roof curb with exhaust capability providing separate air streams for energy recovery from the exhaust air without supply air contamination.
 - b. Formed galvanized steel with wood nailer strip and shall be capable of supporting entire unit weight.
 - c. Permits installation and securing of ductwork to curb prior to mounting unit on the curb.
14. High-Static Indoor Fan Motor(s) and Drive(s):
- a. High-static motor(s) and drive(s) shall be factory-installed to provide additional performance range.

15. Outdoor Air Enthalpy Sensor:
 - a. The outdoor air enthalpy sensor shall be used to provide single enthalpy control. When used in conjunction with a return air enthalpy sensor, the unit will provide differential enthalpy control. The sensor allows the unit to determine if outside air is suitable for free cooling.
16. Return Air Enthalpy Sensor:
 - a. The return air enthalpy sensor shall be used in conjunction with an outdoor air enthalpy sensor to provide differential enthalpy control.
17. Indoor Air Quality (CO₂) Sensor:
 - a. Shall be able to provide demand ventilation indoor air quality (IAQ) control.
 - b. The IAQ sensor shall be available in duct mount. The setpoint shall have adjustment capability.
18. Smoke detectors (Supply):
 - a. Shall be a Four–Wire Controller and Detector.
 - b. Shall be environmental compensated with differential sensing for reliable, stable, and drift–free sensitivity.
 - c. Shall use magnet–activated test/reset sensor switches.
 - d. Shall have tool–less connection terminal access.
 - e. Shall have a recessed momentary switch for testing and resetting the detector.
 - f. Controller shall include:
 - (1.) One set of normally open alarm initiation contacts for connection to an initiating device circuit on a fire alarm control panel.
 - (2.) Two Form–C auxiliary alarm relays for interface with rooftop unit or other equipment.
 - (3.) One Form–C supervision (trouble) relay to control the operation of the Trouble LED on a remote test/reset station.
 - (4.) Capable of direct connection to two individual detector modules.
 - (5.) Can be wired to up to 14 other duct smoke detectors for multiple fan shutdown applications
19. Winter start kit
 - a. Shall contain a bypass device around the low pressure switch.
 - b. Shall be required when mechanical cooling is required down to 25°F (–4°C).
 - c. Shall not be required to operate on an economizer when below an outdoor ambient of 40°F (4°C).
20. Time Guard
 - a. Shall prevent compressor short cycling by providing a 5–minute delay (±2 minutes) before restarting a compressor after shutdown for any reason.
 - b. One device shall be required per compressor.
21. Electric Heat:
 - a. Heating Section
 - (1.) Heater element open coil resistance wire, nickel–chrome alloy, 0.29 inches inside diameter, strung through ceramic insulators mounted on metal frame. Coil ends are staked and welded to terminal screw slots.
 - (2.) Heater assemblies are provided with integral fusing for protection of internal heater circuits not exceeding 48 amps each. Auto reset thermo limit controls, magnetic heater contactors (24 v coil) and terminal block all mounted in electric heater control box (minimum 18 ga galvanized steel) attached to end of heater assembly.
22. Barometric Hood (Horizontal Economizer Applications)
 - a. Shall be required when a horizontal economizer and barometric relief are required. Barometric relief damper must be installed in the return air (horizontal) duct work. This hood provides weather protection.
23. Display Kit for Variable Frequency Drive
 - a. Kit allows the ability to access the VFD controller programs to provide special setup capabilities and diagnostics.
 - b. Kit contains display module, mounting bracket and communication cable.
 - c. Display Kit can be permanently installed in the unit or used on any 2–Speed Indoor Fan Motor VFD controller as needed.