

COLLECTOR BOX REPLACEMENT KIT

For use with 35-in. (889 mm)

High Efficiency Condensing Gas Furnace

Installation Instructions

NOTE: Read the entire instruction manual before starting the installation.

COLLECTOR BOX REPLACEMENT KIT NUMBERS

SAFETY CONSIDERATIONS

Improper installation, adjustment, alteration, service, maintenance, or use can cause explosion, fire, electrical shock, or other conditions which may cause death, personal injury, or property damage. Consult a qualified installer, service agency, or your distributor or branch for information or assistance. The qualified installer or agency must use factory-authorized kits or accessories when modifying this product. Refer to the individual instructions packaged with the kits or accessories when installing.

Follow all safety codes. Wear safety glasses, protective clothing, and work gloves. Have a fire extinguisher available. Read these instructions thoroughly and follow all warnings or cautions include in literature and attached to the unit. Consult local building codes, the current editions of the National Fuel Gas Code (NFGC) NFPA 54/ANSI Z223.1 and the National Electrical Code (NEC) NFPA 70.

In Canada, refer to the current editions of the National Standards of Canada CAN/CSA-B149.1 and .2 Natural Gas and Propane Installation Codes, and Canadian Electrical Code CSA C22.1.

Recognize safety information. This is the safety-alert symbol . When you see this symbol on the unit and in instructions or manuals, be alert to the potential for personal injury.

Understand the signal words DANGER, WARNING, and CAUTION. These words are used with the safety-alert symbol. DANGER identifies the most serious hazards which will result in severe personal injury or death. WARNING signifies hazards which could result in personal injury or death. CAUTION is used to identify unsafe practices which may result in minor personal injury or product and property damage. NOTE is used to highlight suggestions which will result in enhanced installation, reliability, or operation.

WARNING

FIRE, EXPLOSION, ELECTRICAL SHOCK HAZARD

Failure to follow this warning could result in personal injury, death and/or property damage.

The ability to properly perform maintenance on this equipment requires certain knowledge, mechanical skills, tools, and equipment. If you do not possess these, do not attempt to perform any maintenance on this equipment other than those procedures recommended in the Owner's Manual.

WARNING

FIRE, EXPLOSION, ELECTRICAL SHOCK AND CARBON MONOXIDE POISONING HAZARD

Failure to follow this warning could result in personal injury, death or property damage.

Improper installation, adjustment, alteration, service, maintenance, or use can cause carbon monoxide poisoning, explosion, fire, electrical shock, other conditions, which could result in personal injury or death. Consult your distributor or branch for information or assistance. The qualified installer or agency must use only factory-authorized kits or accessories when servicing this product.

WARNING

ELECTRICAL SHOCK HAZARD

Failure to follow this warning could result in personal injury or death, or property damage.

Before installing, modifying, or servicing system, main electrical disconnect switch must be in the OFF position and install a lockout tag. There may be more than one electrical supply to the furnace. Check accessories and cooling unit for additional electrical supplies that must be shut off during furnace servicing. Lock out and tag switch with a suitable warning label. Verify proper operation after servicing.

CAUTION

CUT HAZARD

Failure to follow this caution may result in personal injury.

Sheet metal parts may have sharp edges or burrs. Use care and wear appropriate protective clothing, safety glasses and gloves when handling parts, and servicing furnaces.

INTRODUCTION

This instruction covers the Collector Box replacement on 35-inch (889 mm) high, high efficiency condensing gas furnaces with hot surface ignition. The Collector Box should be replaced when the Collector Box is cracked or warped.

There are four different Collector Box assemblies to service all Single-stage, Two-stage, and Modulating furnaces. Each Collector Box assembly is matched to the cabinet width of the furnace.

DESCRIPTION AND USAGE

The Collector Box Kit contains a Collector Box and the necessary gaskets and screws to replace a Collector Box. [Table 1](#) lists the kit contents.

[Table 2](#) list the furnace input to the appropriate Collector Box Kit.

Table 1 – Kit Contents

QUANTITY	DESCRIPTION
1	Collector Box Assembly
2	Condensate Trap Gasket
4	Collector Box Drain Plug
1	Collector Box Gasket
1	Inducer Housing Inlet Gasket
2	Inducer Housing Drain Gaskets
8	Screws with Washers

Table 2 – Where Used

INSTALLATION

CASING WIDTH IN. (MM)	INPUT BTUH	KIT NUMBER
14-3/16 (360)	26,000	1193444
	40,000	
	60,000	
17-1/2 (445)	40,000	1193445
	60,000	
	80,000	
21 (533)	60,600	1193446
	80,000	
	100,000	
24-1/2 (662)	120,000	1193447
	140,000	

Unit Shut Down

! WARNING

ELECTRICAL SHOCK, FIRE OR EXPLOSION HAZARD

Failure to follow this warning could result in personal injury or death, or property damage.

Before installing, modifying, or servicing system, main electrical disconnect switch must be in the OFF position and install a lockout tag. There may be more than one electrical supply to the furnace. Check accessories and cooling unit for additional electrical supplies that must be shut off during furnace servicing. Lock out and tag switch with a suitable warning label. Verify proper operation after servicing.

1. Set room thermostat to lowest setting or "OFF."
2. Disconnect power at external disconnect, fuse or circuit breaker.
3. Turn off gas at external shut-off or gas meter.
4. Remove outer doors and set aside.
5. Turn electric switch on gas valve to OFF.

Vent Pipe Removal

NOTE: The vent pipe may be connected to the furnace at the rubber vent pipe support. Before cutting the vent pipe, loosen the clamps around the vent pipe coupling and move the vent pipe away from the furnace. Support the vent pipe as close to the furnace as possible to prevent damage to the vent system.

NOTE: If the vent pipe passes through the vent pipe coupling into the vent elbow on the inducer, it may be necessary to cut the vent pipe external to the casing, then re-cement the vent pipe with a field-supplied coupling.

1. Support the vent pipe as close to the furnace as possible to prevent damage to the vent system.
2. Cut vent pipe with a hacksaw and move the remaining vent pipe out of the way. Secure the vent pipe if necessary.
3. Loosen both clamps at the vent pipe support attached to furnace casing.
4. Loosen clamp for the vent pipe at vent elbow on the inducer assembly.

5. Remove remaining vent pipe through the top of the furnace casing and set aside.

Remove J-Box and Main Harness

! CAUTION

UNIT OPERATION HAZARD

Failure to follow this caution may result in unit damage or improper operation.

Label all wires prior to disconnection when servicing controls.

! ATTENTION

D'EQUIPEMENT D'OPERATION

Toute erreur de câblage peut être une source de danger et de panne.

Lors des opérations d'entretien des commandes, étiqueter tous les fils avant de les déconnecter.

NOTE: Depending on the location of the J-Box and cover, it may not be necessary to remove the J-Box cover or bracket to remove the Collector Box. If the J-Box cover and bracket interfere with the removal of the Collector Box, remove the J-Box as shown below:

1. Remove the blower door.
2. Remove the screw that secures the J-Box cover to the J-Box bracket and set the cover aside.
3. Disconnect the field wiring from the factory wiring and remove the ground wire from the green ground screw on the J-Box bracket.
4. Remove factory wiring from the J-Box.
5. Disconnect the factory wires from the main limit switch.
6. Remove the screw that secures the door switch to the blower shelf.
7. Remove main harness from the slot in the blower shelf.

Condensate Drain and Trap Removal

NOTE: If the condensate trap is removed, a new gasket between the trap and Collector Box is required.

1. Disconnect external drain from condensate drain elbow or drain extension pipe inside the furnace and set aside
2. Disconnect the condensate trap relief hose from Collector Box port and the molded retainer clips on the inducer housing.

NOTE: If condensate has a heat pad attached to the trap, trace the wires for the pad back to the connection point and disconnect the wires for the heat pad.

3. Remove the screw that secures the condensate trap to the Collector Box, remove the trap and set aside.
4. Remove the trap gasket from the Collector Box if it did not come off when the trap was removed.
5. Discard the old trap gasket.
6. Rinse condensate trap in warm water until trap is clean.
7. Flush condensate lines with warm water.
8. Shake trap dry.

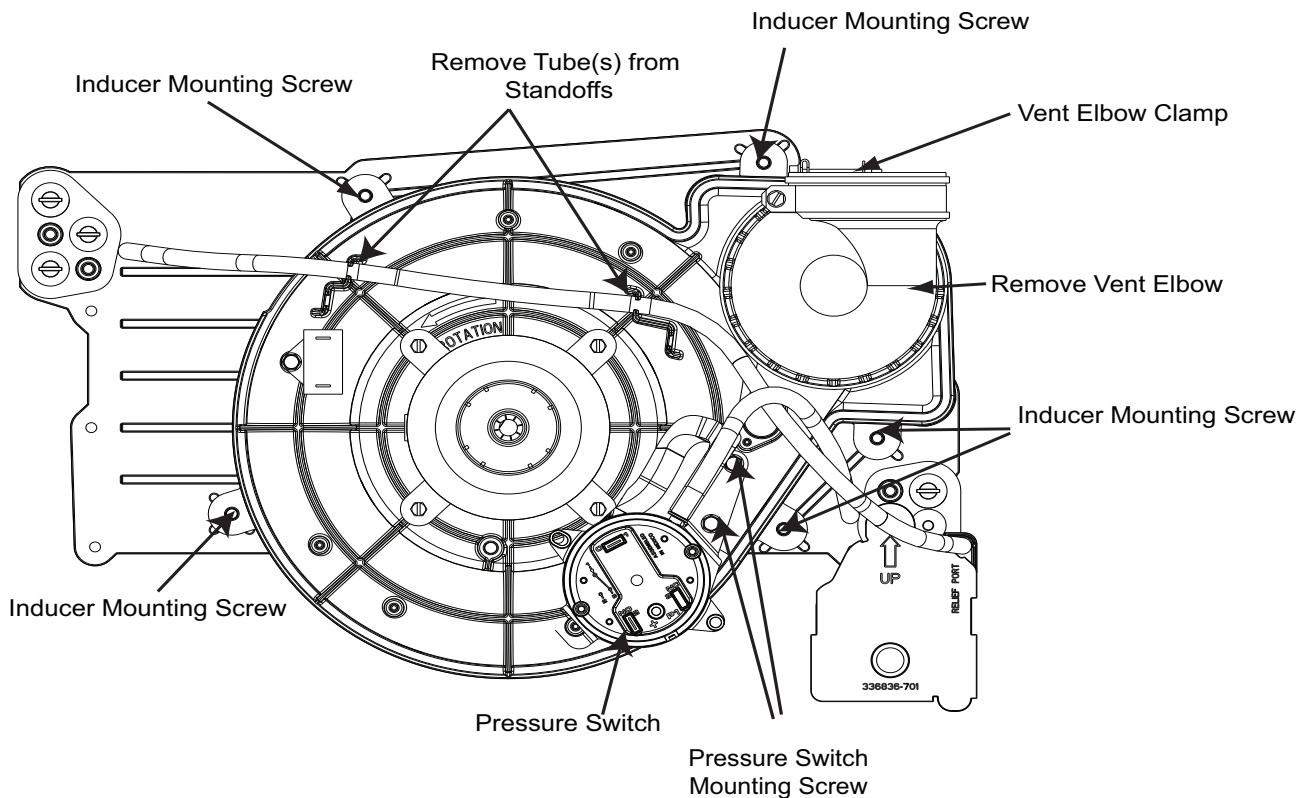

**Fig. 1 – Inducer Assembly Motor Image
(Motor Image, Component Location May Vary)**

A11361

Pressure Switch Removal

 CAUTION
UNIT OPERATION HAZARD Failure to follow this caution may result in unit damage or improper operation. Label all wires prior to disconnection when servicing controls.

 ATTENTION
D'EQUIPEMENT D'OPERATION Toute erreur de câblage peut être une source de danger et de panne. Lors des opérations d'entretien des commandes, étiqueter tous les fils avant de les déconnecter.

NOTE: There are two types of pressure switches. The modulating pressure switch assembly has three pressure switches. Two are side-by-side with the third switch mounted to the back of one of the switches.

All other single and two-stage furnaces have two pressure switches mounted back-to-back.

PSC inducer pressure switches have a tube on the back pressure switch that connects to the port on the inducer assembly.

Modulating pressure switches do not have a port on the rear pressure switch

1. Remove the front pressure switch tube from the port on the Collector Box, see Fig. 1.
2. Modulating - Disconnect the pressure switch harness from the main wiring harness
 Non-Modulating - remove the individual wires from the front

pressure switch.

Note the location of the wires for reassembly.

3. Remove the screws that attach the pressure switch assembly to the inducer.
4. Remove the back pressure switch tube that connects to the inducer assembly. (PSC only)
5. Remove the wires from the back pressure switch (PSC Only). Note the location of the wires for reassembly.
6. Set the pressure switches aside.
7. If the relief tube for the condensate trap is routed across the inducer assembly, remove the tube from the port on the Collector Box and from the stand-offs on the inducer and move the tube aside.

Inducer Assembly Removal

NOTE: See Fig. 2 for inducer assembly detail and component locations.

1. Remove the door bracket from the front edge of the blower shelf.
2. Remove the wires that connect the main wiring harness to the inducer motor harness.
3. Remove the condensate trap relief tube from the port on the Collector Box and the stand-offs on the inducer housing.
4. Remove the screws from the tabs on inducer assembly that secures the inducer to the Collector Box. Note there is one mounting tab directly under the vent elbow.
5. Remove the inducer assembly and set aside.

Collector Box Removal

1. Remove the screws that secure the Collector Box to the heat exchanger cell panel and discard.

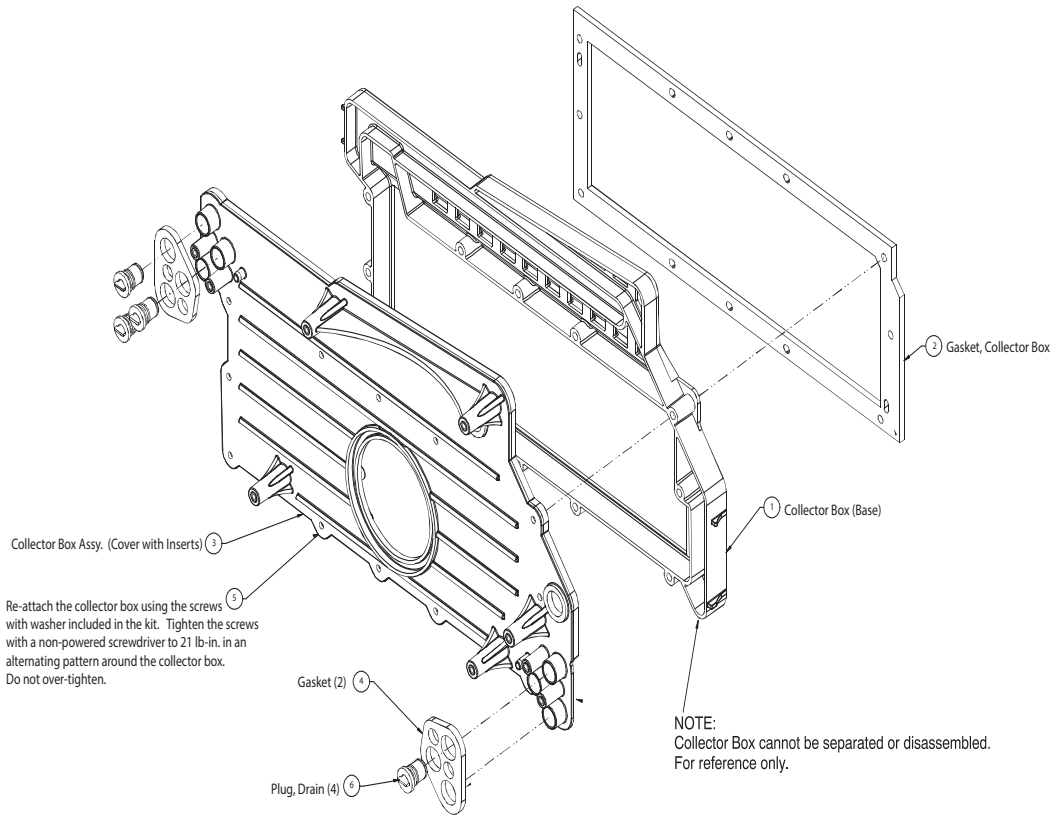

Fig. 2 – Collector Box

A200516

Collector Box Installation

1. Verify old Collector Box gasket has been removed from heat exchanger.

NOTE: There is a slot on each side of the front panel of the condensing heat exchanger. The Collector Box has alignment tabs on the back that fit into the slots on the condensing heat exchanger panel.

2. Verify Collector Box gasket is installed on the back of the Collector Box.
3. Verify the condensate trap gaskets are installed on the drain outlets of the Collector Box.
4. Align the tabs on the Collector Box to the slots condensing heat exchanger.
5. With the Collector Box fully seated against the condensing heat exchanger cell panel, install the screws with washers (included in the kit) through the Collector Box.



CAUTION

UNIT OPERATION HAZARD

Failure to follow this caution may result in unit damage or improper operation.

Over-torquing the screws may result in a cracked Collector Box.

6. Tighten the screws with a non-powered screwdriver to 21 lb-in. in an alternating pattern around the Collector Box. Do not over-tighten.

Replace Inducer Assembly Gaskets

1. Remove the old gasket from around the inlet to the inducer assembly
2. Remove the two gaskets around the drain stubs of the inducer assembly. Verify that the surfaces around the drain stubs are clean and smooth.

3. Remove the adhesive backing from a inducer housing drain gasket and attach the gasket over the drain stub of the inducer assembly
4. Repeat the procedure for the other drain stub
5. Insert the inducer inlet gasket in the groove around the inlet of the inducer assembly
6. Verify the gasket is fully seated in the groove.

Inducer Assembly Installation

1. Verify the Inlet Choke Plate (when used) is installed on the inlet opening of the inducer.
2. Align the tabs on inducer assembly to the brass inserts on the Collector Box.
3. Insert the mounting screws by hand through the tabs to secure the inducer to the Collector Box. Remember there is a mounting tab located under the vent elbow.
4. Tighten the screws in an alternating pattern by hand. Do not use a screw gun or over-tighten the mounting screws.
5. Connect the inducer leads from the main wiring harness to the inducer motor harness.

Install J-Box and Main Harness

NOTE: If the J-Box cover and bracket were removed as part of the Collector Box replacement, install the J-Box and bracket as shown below:

1. Insert grommet for main harness in the slot in the blower shelf.
2. Align the door switch to the blower shelf.
3. Install the screw to secure the door switch.
4. Install the door bracket to the front edge of the blower shelf.
5. Connect the field wiring from the factory wiring and attach the ground wire to the green ground screw on the J-Box bracket.
6. Attach the J-Box cover to the J-Box bracket
7. Install the screw to secure the J-Box cover to the bracket.
8. Connect the factory wires to the main limit switch.

Pressure Switch Installation

NOTE: There are two types of pressure switches. The modulating pressure switch assembly has three pressure switches. Two are side-by-side with the third switch mounted to the back of one of the switches.

All other furnaces have two pressure switches mounted back-to-back.

The tube for the front pressure switch connects the switch to the port on the Collector Box. The tube for the switch mounted on the back connects the switch to the port on the inducer assembly.

1. Connect the wires to the back pressure switch.
2. Connect the tube for the back pressure switch to the inducer assembly. (PSC only)
3. Connect the tube for the front pressure switch to the port on the Collector Box.
4. Attach the pressure switch assembly to the inducer.
5. Modulating - connect the pressure switch harness to the main wiring harness
Non-Modulating - attach the individual wires to the pressure switch.

Install the Condensate Trap and Drain

NOTE: If the condensate trap is removed, a new gasket between the trap and Collector Box is required. Verify the condensate trap gasket was installed as outlined in "Collector Box Installation".

1. Align the trap with the drain outlet on the Collector Box.
2. Secure the trap to the Collector Box with the screw.
3. Connect the condensate trap relief tube from Collector Box port and insert the tube into the molded retainer clips on the inducer housing.
4. Insert the condensate drain elbow through the casing until it is properly seated. Or, connect the drain elbow to the drain extension pipe and route the pipe behind the inducer.
5. Connect the drain elbow to the condensate trap.

NOTE: If condensate has a heat pad attached to the trap, trace the wires for the pad back to the connection point and connect the wires for the heat pad.

Vent Pipe Installation

1. Orient the vent elbow in the required location. Torque the vent elbow clamp 15 lb-in.
2. Insert the vent pipe through the furnace casing and into the outlet of the inducer vent elbow.
3. Tighten the clamp for the vent pipe at vent elbow on the inducer assembly 15 lb-in.
4. Align the remaining vent pipe system to the vent pipe in the furnace casing.
5. If the pipe was cut, solvent cement the pipes as required for the type of material used.
6. Tighten both clamps at the vent pipe support attached to furnace casing 15 lb-in.

Unit Checkout

WARNING

FIRE OR EXPLOSION HAZARD

Failure to follow this warning could result in personal injury, death, and/or property damage.

Never purge a gas line into a combustion chamber. Never test for gas leaks with an open flame. Use a commercially available soap solution made specifically for the detection of leaks to check all connections. A fire or explosion may result causing property damage, personal injury or loss of life.

AVERTISSEMENT

RISQUE D'EXPLOSION ET D'INCENDIE

Le non-respect des avertissements de sécurité pourrait d'entraîner des blessures graves, la mort ou des dommages matériels.

Ne jamais utiliser une flamme nue pour vérifier la présence des fuites de gaz. Pour la vérification de tous les joints, utiliser plutôt une solution savonneuse commerciale fabriquée spécifiquement pour la détection des fuites de gaz. Un incendie ou une explosion peut entraîner des dommages matériels, des blessures ou la mort.

1. Set thermostat to "OFF".
2. Turn on power at external disconnect, fuse or circuit breaker.
3. Turn on gas at external shut-off or gas meter.
4. Check for gas leaks with a commercially available soap solution made specifically for the detection of leaks to check all connections.
5. Manually close blower door switch.

WARNING

ELECTRICAL OPERATION HAZARD

Failure to follow this warning could result in personal injury or death.

Blower door switch opens 115-v power to control. No component operation can occur unless switch is closed. Caution must be taken when manually closing this switch for service purposes.

6. Initiate component test through circuit board by referring to "Component Test" on status code label on blower access door for complete test sequence information.
7. If any status codes are flashed, refer to status code label on unit blower door.
8. Turn thermostat fan switch to "ON", "Continuous" or jumper R to G terminals at furnace control board.
9. Check for air leakage around cell panel. It may be necessary to remove heat exchanger assembly and top gasket between cell panel and furnace casing top plate. Re-install and re-check for blower air leaks.
10. Remove jumper(s) or set thermostat fan to "Auto" or "OFF."
11. Release blower door switch.
12. Install blower access door.
13. Set thermostat to call for heat.
14. Allow unit to initiate a complete call for heat cycle.
15. Check for air leakage around Collector Box. A whistling noise may indicate air leak in Collector Box seal.
16. Allow the call for heat to continue until water drains out the condensate drain. Check for water leaks around the Collector Box and inducer assembly.

NOTE: If there is a severe air leak in the Collector Box seal, pressure switch may not close or will re-open, resulting in no ignition or erratic burner operation.

NOTE: As part of the system check-out, verify that the following conditions are not affecting the operation of the furnace:

- Short Cycling-Defective thermostat: Incorrect thermostat anticipator setting, dirty filter or over-sized furnace.
- Under firing/low BTU input: Set manifold pressure and verify firing rate as shown on rating plate by clocking the gas meter.
- Overfiring/high BTU input: Set manifold pressure and verify firing rate as shown on rating plate by clocking the gas meter.
- Low temperature rise: Set unit for correct temperature rise range as shown on unit rating plate.

- Contaminated combustion air: Remove contaminants or provide ample fresh air for combustion.
 - Excessive amounts of outside ventilation air: Return air temperature cannot be below 60 degrees F for extended periods of time.
 - Incorrect venting or termination: Recirculation of products of combustion into the combustion air pipe can damage the furnace. Verify proper venting and vent termination per installation instructions. For additional information, and a complete sequence of furnace operation, refer to furnace Installation, Start-Up and Operating Instructions.
17. After System Check-out is complete, set thermostat below room temperature.
 18. Verify that burner shuts down and blower completes selected off delay time.
 19. Verify furnace operates properly and set thermostat to desired room temperature.
 20. Re-install outer doors.