

**PART NUMBER:
CPLOWAMB001A00
CPLOWAMB002A00**

**SMALL PACKAGED PRODUCTS
1-1/2 TO 5 TONS (50/60 HZ)
MOTORMASTER II HEAD PRESSURE CONTROLLER**

Installation Instructions

NOTE: Read the entire instruction manual before starting the installation.

SAFETY CONSIDERATIONS

Installation and servicing of this equipment can be hazardous due to mechanical and electrical components. Only trained and qualified personnel should install, repair, or service this equipment.

Untrained personnel can perform basic maintenance functions such as cleaning and replacing air filters. All other operations must be performed by trained service personnel. When working on this equipment, observe precautions in the literature, on tags, and on labels attached to or shipped with the unit and other safety precautions that may apply.

Follow all safety codes. Installation must be in compliance with local and national building codes. Wear safety glasses, protective clothing, and work gloves. Have fire extinguisher available. Read these instructions thoroughly and follow all warnings or cautions included in literature and attached to the unit. In Canada, refer to current editions of the Canadian electrical code CSA 22.1 and current editions of the National Electrical Code (NEC) NFPA 70.

Recognize safety information. This is the safety-alert symbol . When you see this symbol on the unit and in instructions or manuals, be alert to the potential for personal injury. Understand these signal words; DANGER, WARNING, and CAUTION. These words are used with the safety-alert symbol. DANGER identifies the most serious hazards which **will** result in severe personal injury or death. WARNING signifies hazards which **could** result in personal injury or death. CAUTION is used to identify unsafe practices which **may** result in minor personal injury or product and property damage. NOTE is used to highlight suggestions which **will** result in enhanced installation, reliability, or operation.

Follow all safety codes. Wear safety glasses and work gloves. Have a fire extinguisher available.

WARNING

ELECTRICAL SHOCK HAZARD

Failure to follow this warning could cause personal injury or death.

Before performing service or maintenance operations on unit, turn off main power switch to unit and install lockout tag. Ensure electrical service to rooftop unit agrees with voltage and amperage listed on the unit rating plate.

INTRODUCTION

These instructions cover the installation of the Motormaster II Controller head pressure control device. Refer to the Installation section for directions. Louvered panels are required for this installation; see Item 9 in the Installation section of this document and Tables 1 and 2 for more information.

Table 1 – Add Louvered Panels to These Units if available. If Louvered Panel kit is not available for a specific model, Field Fabricated Wind Baffles are recommended.

48ES-A	574D--A	PGD3	PY3G	WPG3
50ES-A	704D--A	PAD3	PA3G	WPA3
48EZ-A	674D--A	PDD3	-	-
50EZ-A	604D--A	PHD3	PH3G	WPH3
-	-	PAD4	-	-
-	-	PGD4	-	-
-	-	PHD4	-	-

Table 2 – Do NOT Add Louvered Panels to These Units

48VL-A	577C--A	-	-	-
50VL-A	707C--A	-	-	-
48VT-A	677C--A	-	-	-
50VT-A	607C--A	-	-	-
50GL-A	-	PA4E	-	-
50JZ-A	-	PH4E	-	-
50ZHB-A	-	PHJ3	PH3Z	WJH3
50ZPB-A	-	PAJ3	PA3Z	WJA3

*Louvered panels are standard on these units.

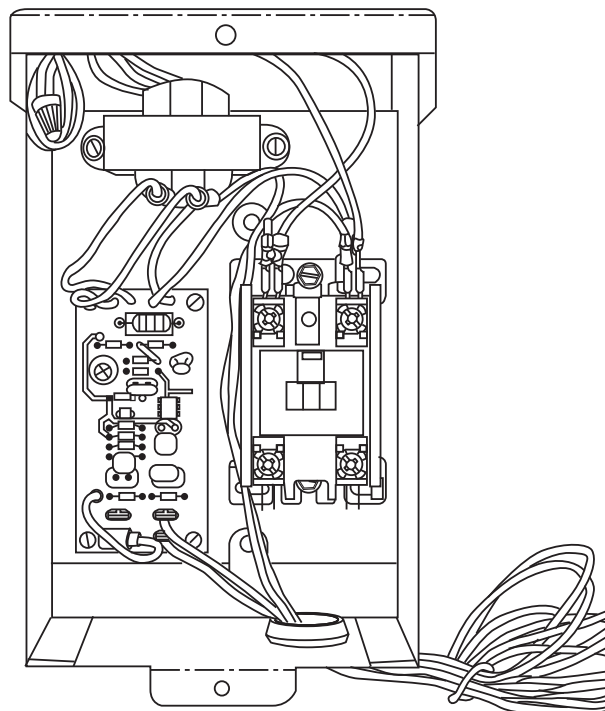

Motormaster® II Controller Interior

Fig. 1 - Controller Interior

C00102

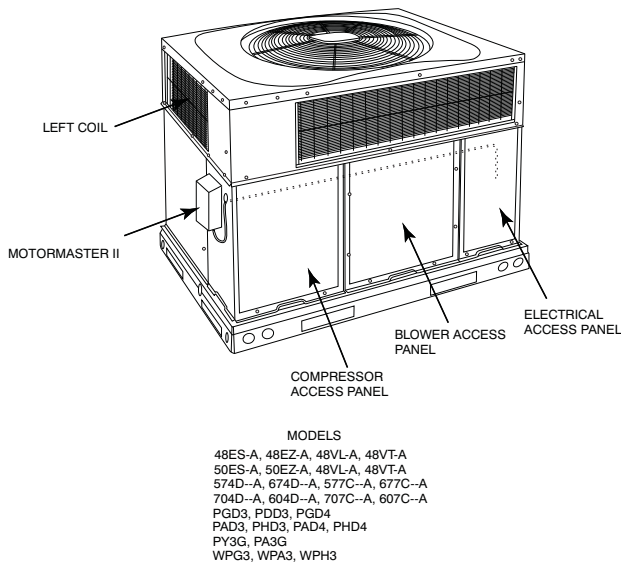

A11089

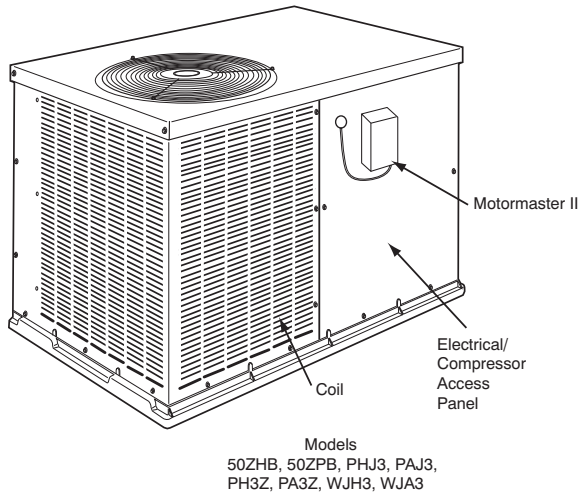

A11090

Fig. 2 - Access Panel and Motormaster Location

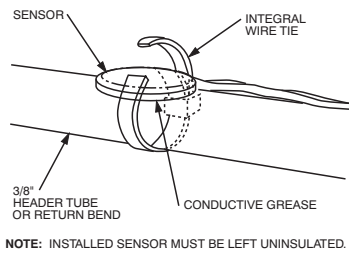

Sensor Connection Details

A11106

Fig. 3 - Connection Details

DESCRIPTION AND USAGE

The Motormaster II head pressure controller is a cycle control device activated by a temperature sensor mounted on a header tube of the outdoor coil (see Fig. 1). It is designed to cycle the outdoor-fan motors to maintain the saturated condensing temperature within normal operating limits of approximately 130 to 110°F high (54°C to 43°C), 70 to 50°F low (21 to 10°C). The controller maintains working head pressure at low ambient temperatures down to -20°F (-29°C) when properly installed.

INSTALLATION

1. Disconnect power to unit. Install lockout tag.
2. Remove unit electrical, blower and compressor access panel. (See Fig. 2.)

3. Disconnect black lead from the outdoor-fan motor (OFM) and connect to Motormaster control (See Wiring Schematic, Fig. 7 or 8).
4. Using a knockout punch and die combination, make hole in the access panel to feed MotormasterII Control wire leads to the side of its mounting location (See Fig. 2 and Fig. 4 or Fig. 5).

NOTE: Field-supplied conduit must be used between controller and access panel (or wire into unit entrance). Created hole on the access panel must be sealed to comply with National Electric Code (NEC).

5. Mount Motormaster II Controller on unit. Refer to Fig. 2 and Fig. 4 or Fig. 5, The controller must be mounted vertically with the leads at the bottom. Using the Mounting Template (Fig. 9) as a guide, drill mounting holes. To ensure electrical ground, insert star washers (supplied with the controller) under the heads of mounting screws.
6. Determine sensor location by referring to Fig. 10-41. Route sensor wire through bottom of Motormaster II Controller (Fig. 1) to sensor location specified. Prior to installation, apply conductive grease supplied with accessory to contact surface of sensor.

⚠ CAUTION

COMPONENT DAMAGE HAZARD

Failure to follow this caution may result in component damage.

Sensor assembly is delicate. Handle with care.

7. Attach sensor to tube as shown in Fig. 3. Installed sensor must be left uninsulated.
8. Power wiring must comply with all local and National Electrical Code (NEC) and International Electric Code (IEC) requirements. Refer to Fig. 7 and 8 for power wiring connections. Coil up all excess wire and secure. (Yellow and blue wires, from controller, must run to unit contactor and connect on the load side.)

⚠ CAUTION

UNIT OPERATION AND COMPONENT DAMAGE HAZARD

Failure to follow this caution may result in improper unit operation or component damage.

All wires must be secured so that they are not in contact with unit tubing.

9. To prevent wind cross-currents from causing abnormally low condensing temperatures, louvered panels are required on some models. See Table 1 and 2 for models requiring/not requiring louvered panels.
10. Screw back all access panels
11. Reconnect power to the unit.

The Motormaster II head pressure controller is equipped with an alternate operating mode. When this mode is selected, the controller shifts the fan cycle sequence to effectively raise the average condensing temperature approximately 20°F (-6.7°C) higher than the standard operating mode. In this alternate mode, the outdoor fan begins cycling at higher outdoor ambient temperatures. This mode should only be used if the evaporator coil shows signs of frosting at low outdoor ambient temperatures.

To select the alternate operating mode, move the jumper wire on the Motormaster II control board from reset T1 to T2.

Refer to Fig. 6 for thermistor resistance vs. temperature.

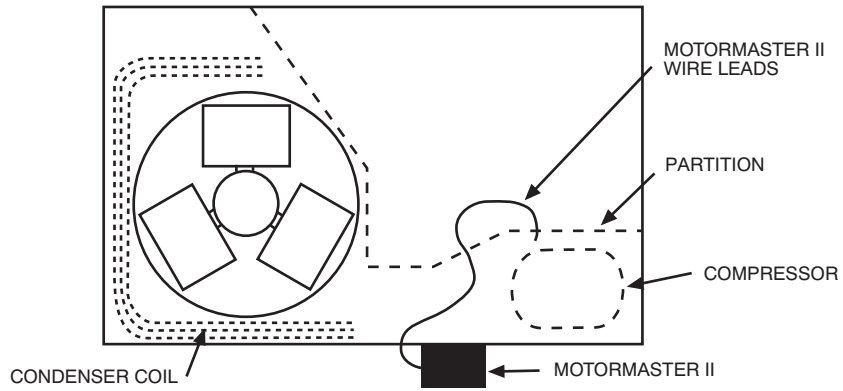

See Step 4 to make hole in access panel.

50ZHB, 50ZPB, PAJ3, PHJ3, PA3Z, PH3Z, WJA3, WJH3

Fig. 4 - Mounting Locations

A11087

CFLOWAMB

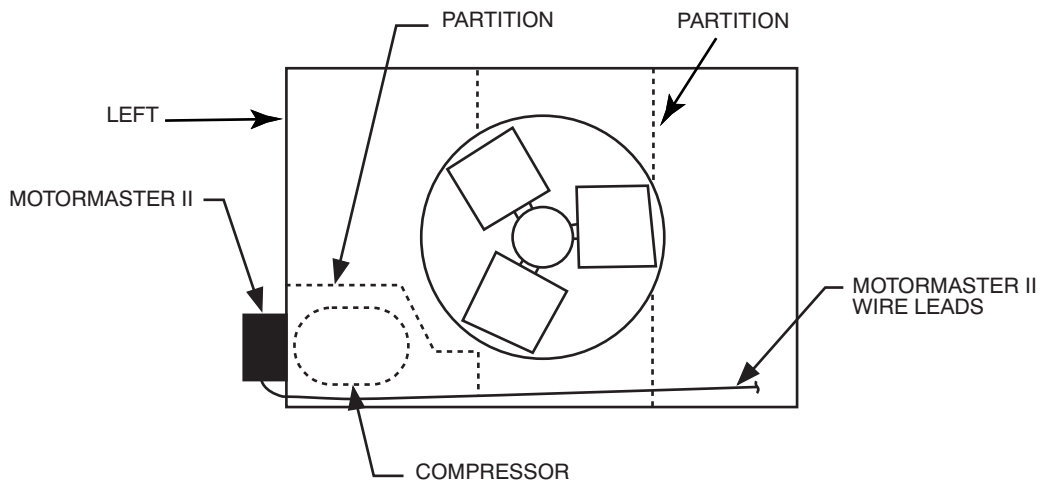

48ES-A, 48EZ-A, 48VL-A, 48VT-A
 50ES-A, 50EZ-A, 50VL-A, 50VT-A
 574D--A, 674D--A, 577C--A, 677C--A
 704D--A, 604D--A, 707C--A, 607C--A
 PGD3, PDD3, PAD3, PHD3, PAD4, PGD4, PHD4
 PA3G, PY3G, PH3G, WPA3, WPG3, WPH3

Fig. 5 - Mounting Locations

A11088

Table 3 – Sensor Location Index

MODEL NUMBER	MODEL NUMBER	MODEL NUMBER	MODEL NUMBER	MODEL NUMBER	FIGURE NUMBER
48ES--A 50ES--A	574D--A 704D--A	PGD3 PAD3	PY3G PA3G	WPG3 WPA3	Fig. 10
					Fig. 11
					Fig. 12
					Fig. 13
					Fig. 14
48EZ--A 50EZ--A	674D--A 604D--A	PDD3 PHD3	PH3G	WPH3	Fig. 15
					Fig. 16
					Fig. 17
					Fig. 18
					Fig. 19
48VL--A 50VL--A	577C--A 707C--A	PGD4 PAD4	--	--	Fig. 20
					Fig. 21
					Fig. 22
					Fig. 23
					Fig. 24
48VT--A 50VT--A	677C--A 607C--A	-- PHD4	--	--	Fig. 25
					Fig. 26
					Fig. 27
					Fig. 28
					Fig. 29
50GL	--	PA4E	--	--	Fig. 30
					Fig. 31
					Fig. 32
					Fig. 33
					Fig. 34
50JZ	--	PH4E	--	--	Fig. 35
					Fig. 36
50ZHB	--	PHJ3	PH3Z	WJH3	Fig. 37
50ZPB	--	PAJ3	PA3Z	WJA3	Fig. 38
					Fig. 39
					Fig. 40
					Fig. 41

CPLOWAMB

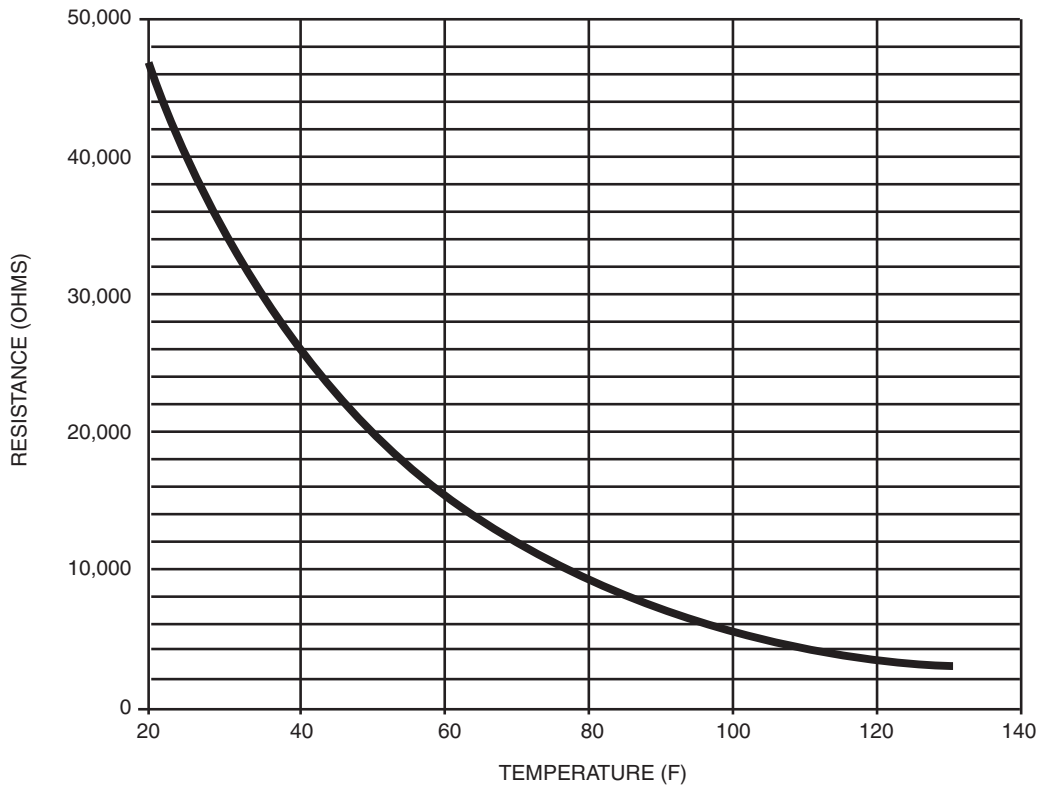

Thermistor Resistance vs Temperature

Fig. 6 - Thermistor Resistance vs. Temperature Chart

C00104

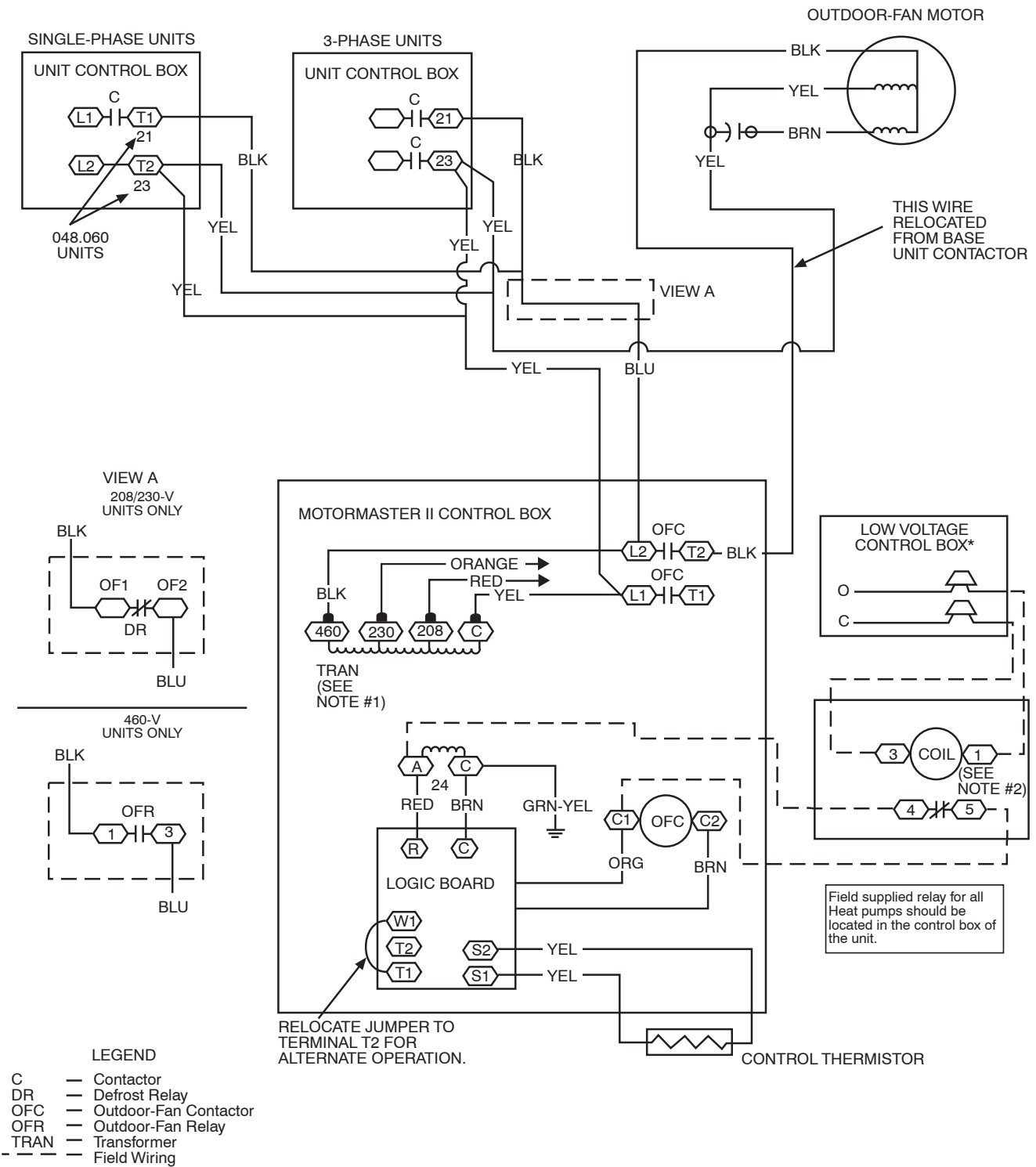
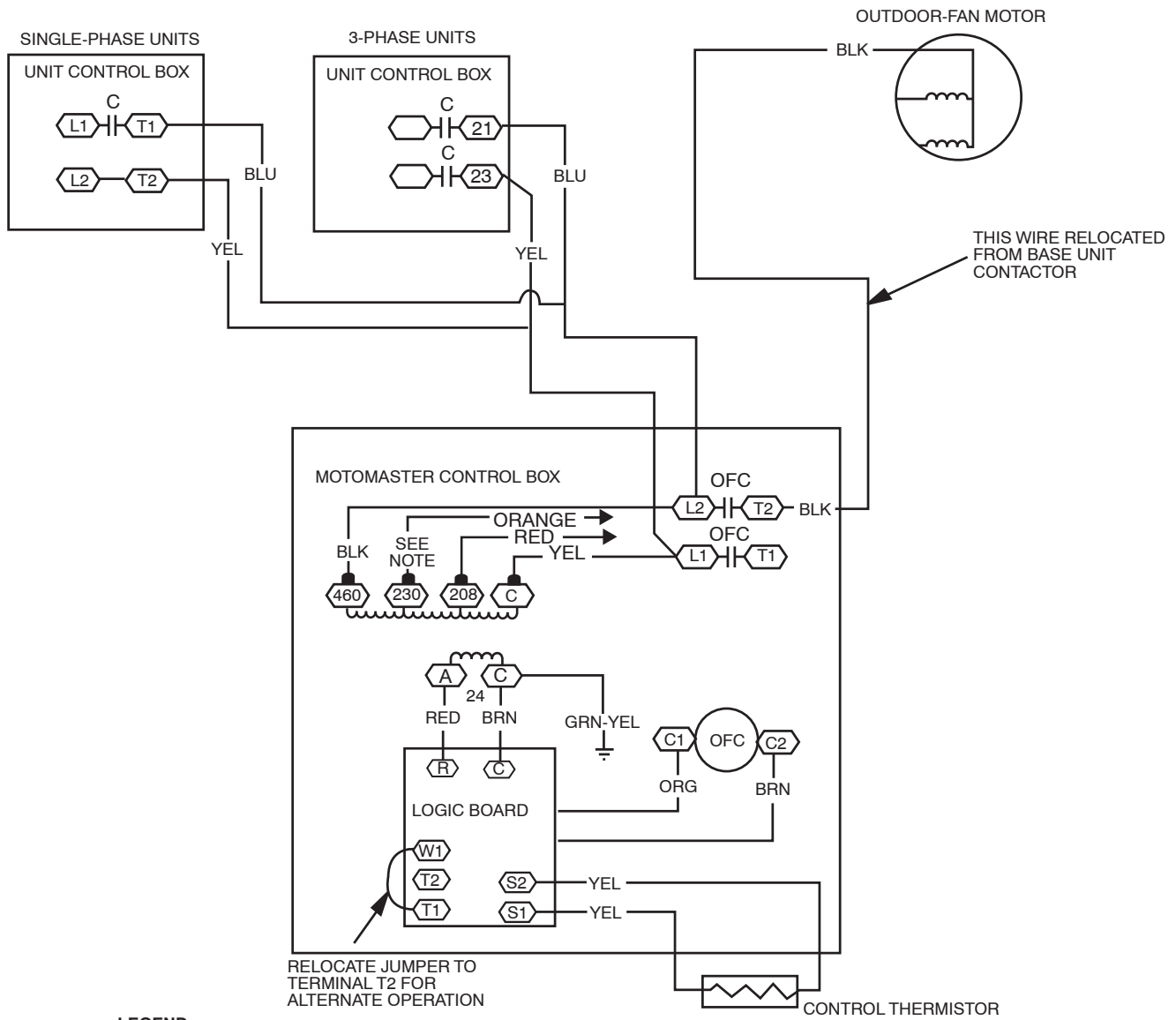

Fig. 7 - Wiring Schematic Heat Pumps

C00106



LEGEND
C - Contactor
OFC - Outdoor- Fan Contactor
TRAN - Transformer

NOTE:
 1. Motormaster® II is wired for 460-v supply; it must be rewired for 208/230-v application. Be sure to insulate unused tap.
 2. CLOWAMB002A00 Transformer only contains a 400V supply.

Fig. 8 - Wiring Schematic, AC and Gas PACs

MOUNTING TEMPLATE

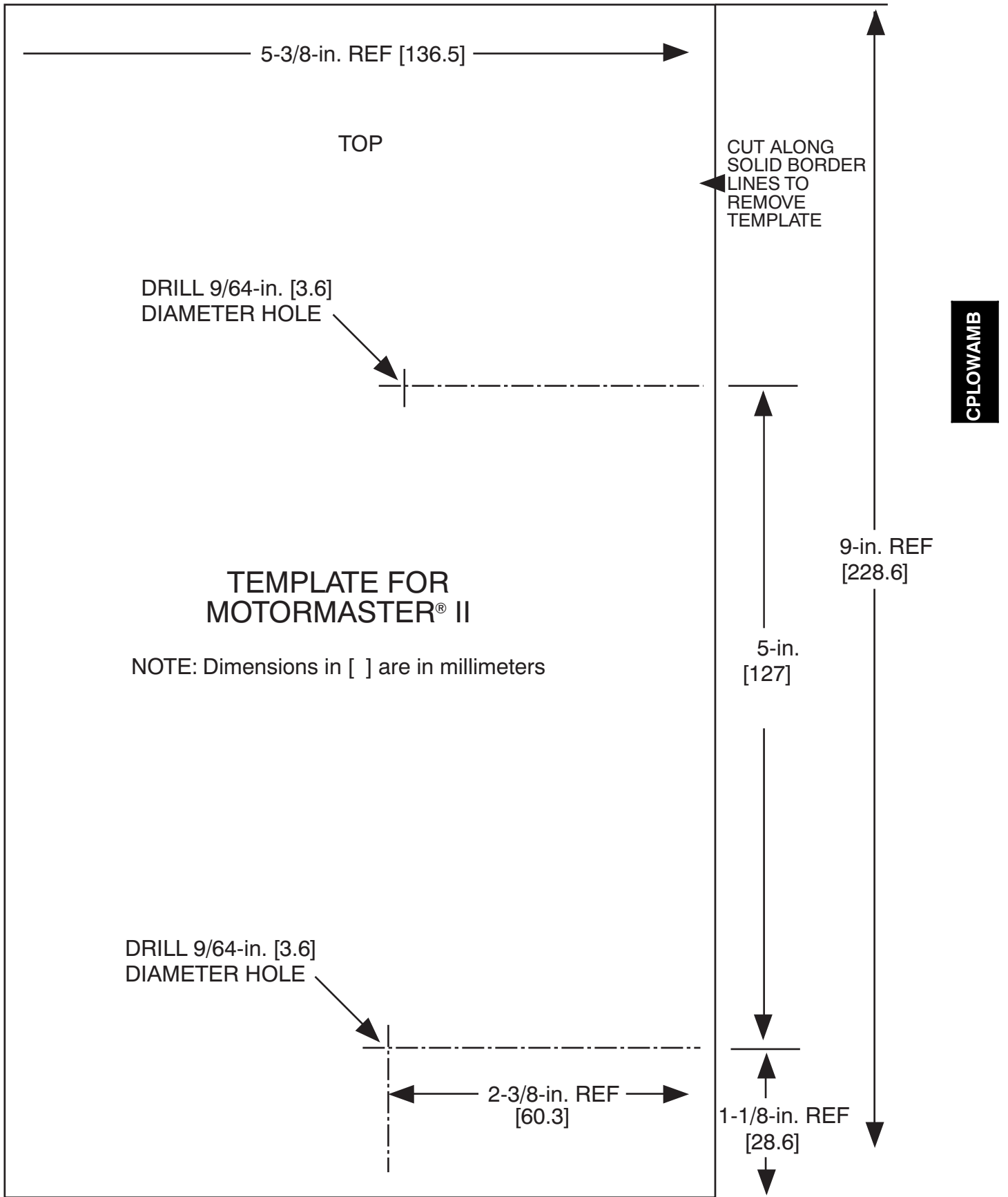
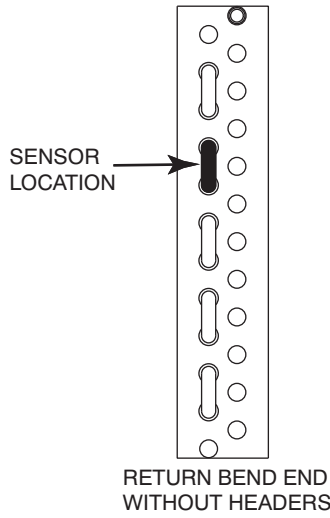

Fig. 9 - Controller Mounting Template

A11110



RETURN BEND END
WITHOUT HEADERS

UNIT SIZE 24
48ES-A 574D--A PGD3 PY3G WPG3
50ES-A 704D--A PAD3 PA3G WPA3

LEFT COIL

Fig. 10 - Sensor Mounting Location

A11057

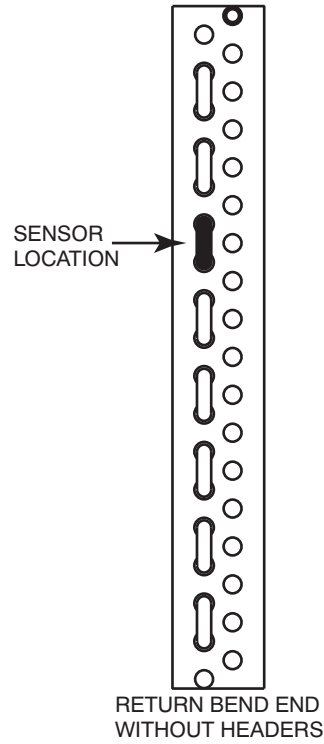

RETURN BEND END
WITHOUT HEADERS

UNIT SIZE 36
48ES-A 574D--A PGD3 PY3G WPG3
50ES-A 704D--A PAD3 PA3G WPA3

LEFT COIL

Fig. 12 - Sensor Mounting Location

A11059

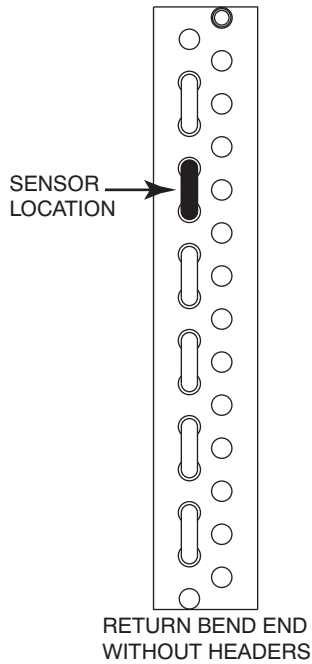

RETURN BEND END
WITHOUT HEADERS

UNIT SIZE 30
48ES-A 574D--A PGD3 PY3G WPG3
50ES-A 704D--A PAD3 PA3G WPA3

UNIT SIZE 24
48VL-A 577C--A PGD4
50VL-A 707C--A PAD4

LEFT COIL

Fig. 11 - Sensor Mounting Location

A11058

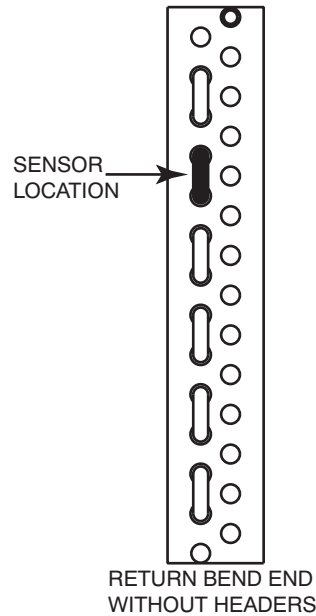

RETURN BEND END
WITHOUT HEADERS

UNIT SIZE 42
48ES-A 574D--A PGD3 PY3G WPG3
50ES-A 704D--A PAD3 PA3G WPA3

LEFT COIL

Fig. 13 - Sensor Mounting Location

A11061

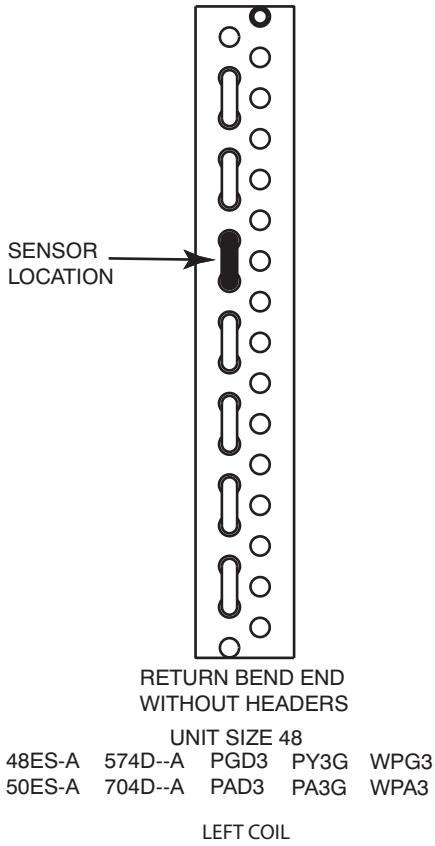

Fig. 14 - Sensor Mounting Location

A11062

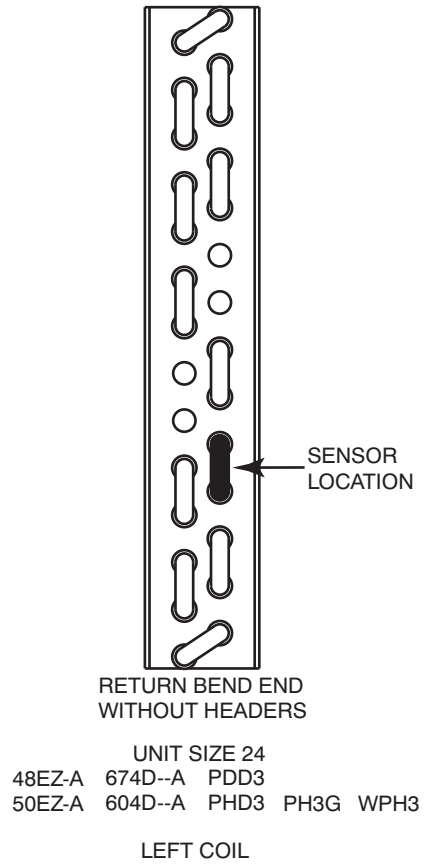

Fig. 16 - Sensor Mounting Location

A11063

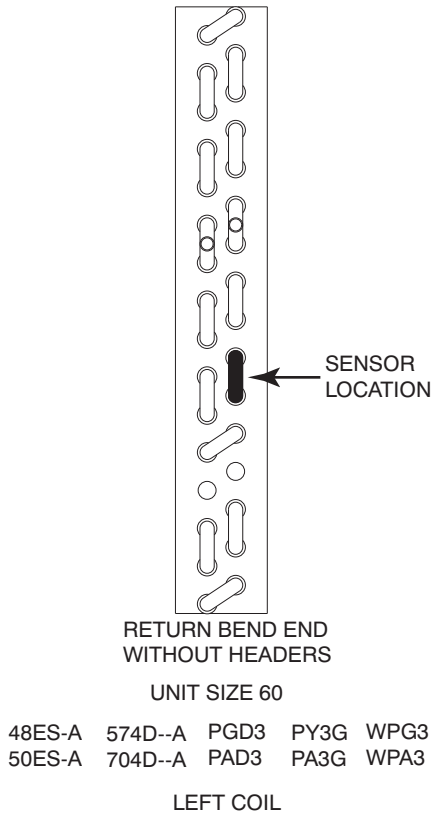

Fig. 15 - Sensor Mounting Location

A11060

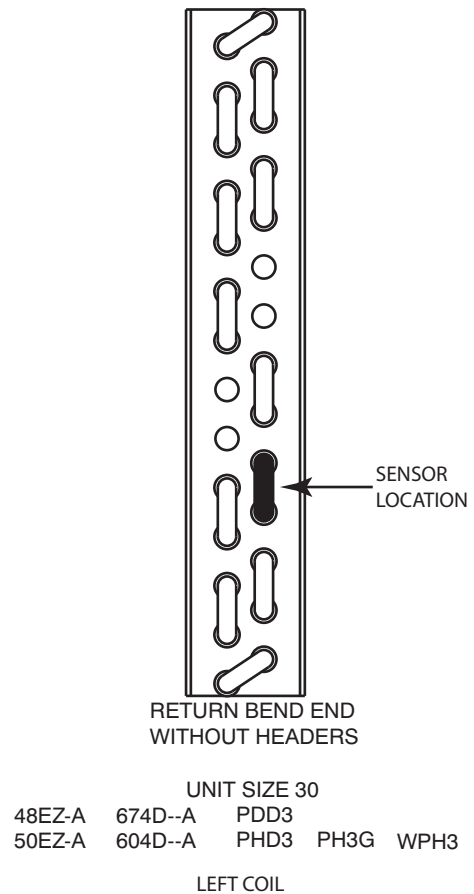
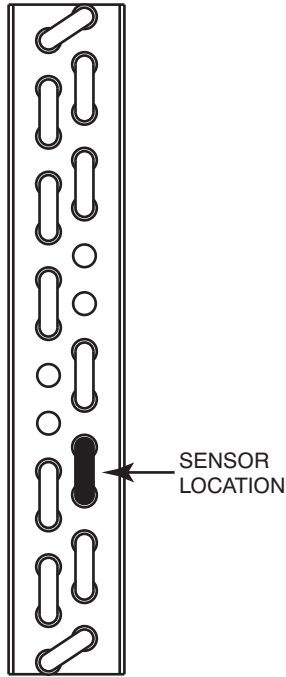

Fig. 17 - Sensor Mounting Location

A11064



RETURN BEND END
WITHOUT HEADERS

UNIT SIZE 36

48EZ-A 674D--A PDD3
50EZ-A 604D--A PHD3 PH3G WPH3

LEFT COIL

Fig. 18 - Sensor Mounting Location

A11065

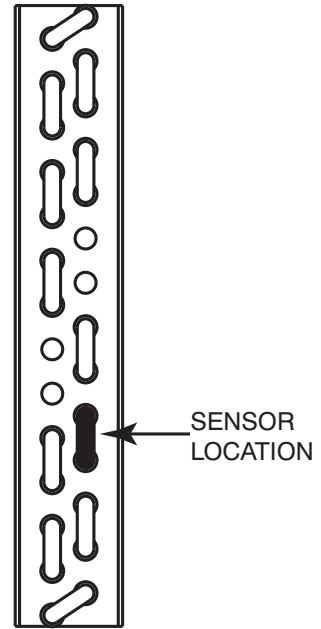

RETURN BEND END
WITHOUT HEADERS

UNIT SIZE 48

48EZ-A 674D--A PDD3
50EZ-A 604D--A PHD3 PH3G WPH3

LEFT COIL

Fig. 20 - Sensor Mounting Location

A11067

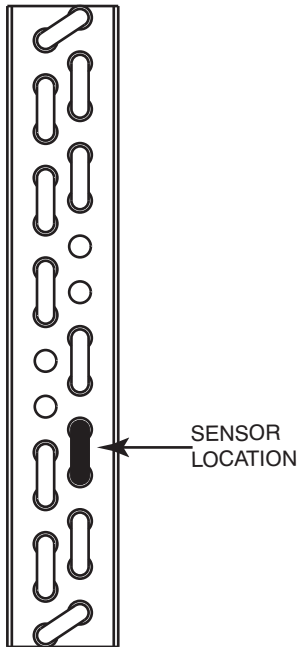

RETURN BEND END
WITHOUT HEADERS

UNIT SIZE 42

48EZ-A 674D--A PDD3
50EZ-A 604D--A PHD3 PH3G WPH3

LEFT COIL

Fig. 19 - Sensor Mounting Location

A11066

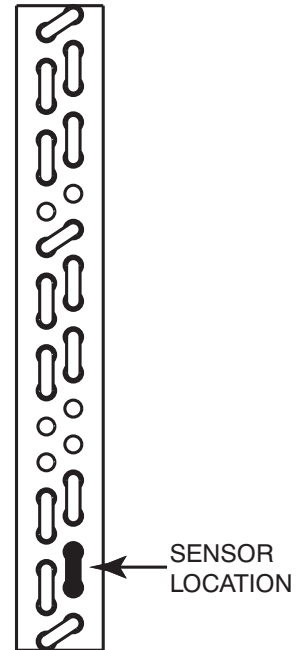

RETURN BEND END
WITHOUT HEADERS

UNIT SIZE 60

48EZ-A 674D--A PDD3
50EZ-A 604D--A PHD3 PH3G WPH3

LEFT COIL

Fig. 21 - Sensor Mounting Location

A11068

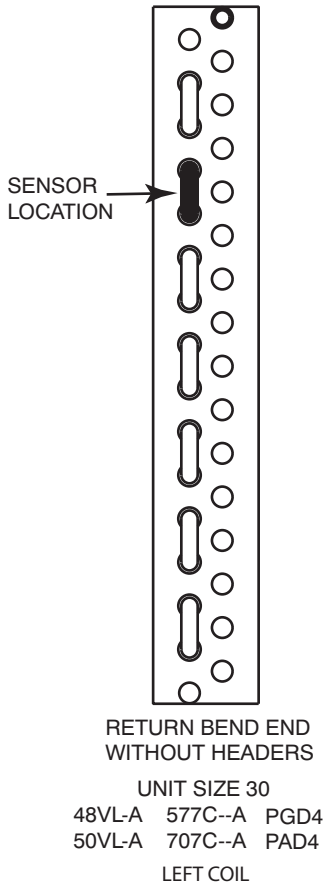

Fig. 22 - Sensor Mounting Location

A11069

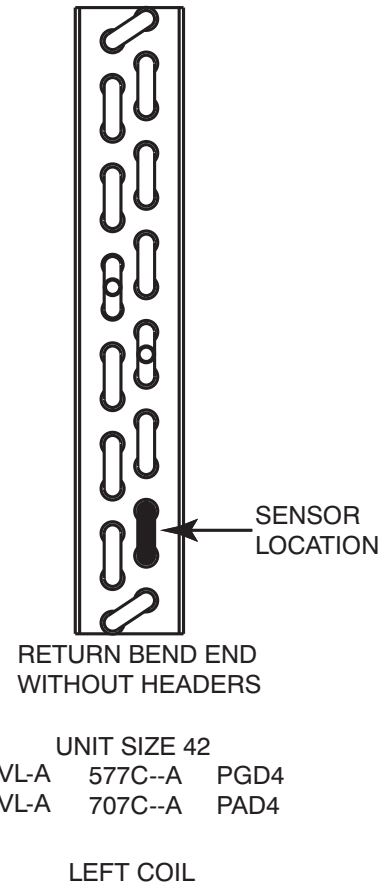

Fig. 24 - Sensor Mounting Location

A11071

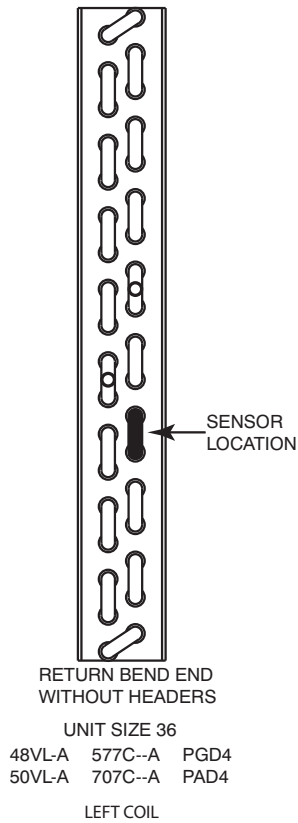

Fig. 23 - Sensor Mounting Location

A11070

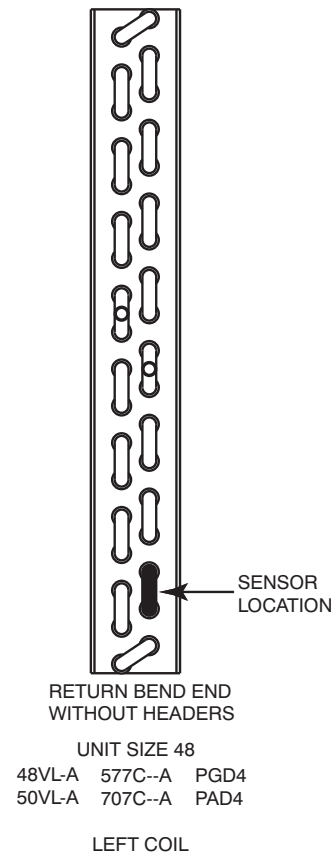
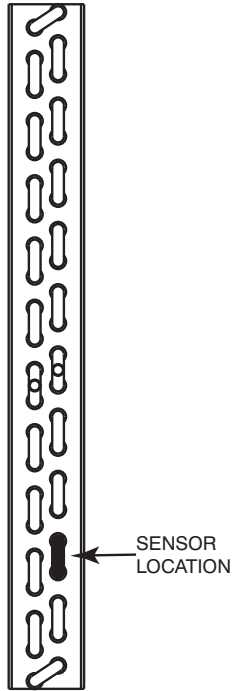

Fig. 25 - Sensor Mounting Location

A11072



RETURN BEND END
WITHOUT HEADERS
UNIT SIZE 60
48VL-A 577C--A PGD4
50VL-A 707C--A PAD4
LEFT COIL

Fig. 26 - Sensor Mounting Location

A11073

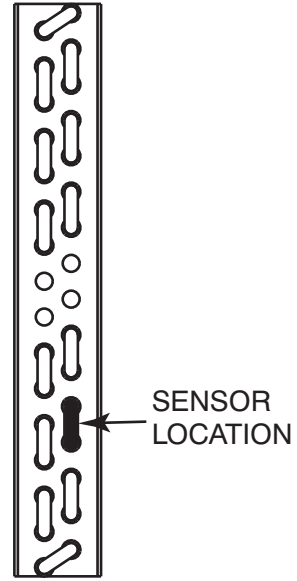

RETURN BEND END
WITHOUT HEADERS

UNIT SIZE 30
48VT-A 677C--A
50VT-A 607C--A PHD4
LEFT COIL

Fig. 28 - Sensor Mounting Location

A11075

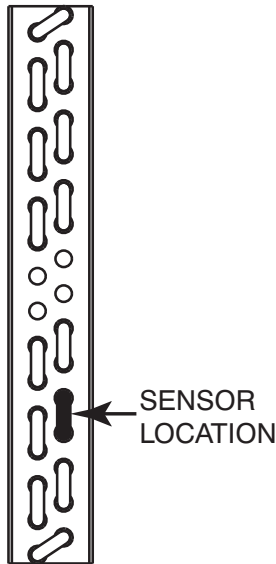

RETURN BEND END
WITHOUT HEADERS

UNIT SIZE 24
48VT-A 677C--A
50VT-A 607C--A PHD4
LEFT COIL

Fig. 27 - Sensor Mounting Location

A11074

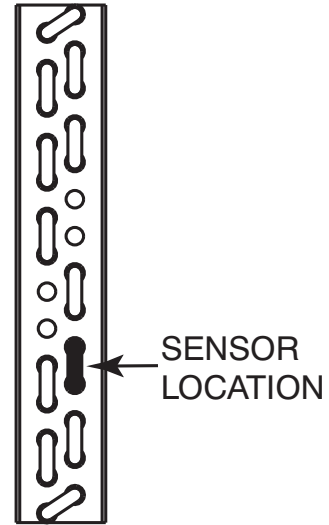

RETURN BEND END
WITHOUT HEADERS

UNIT SIZE 36
48VT-A 677C--A
50VT-A 607C--A PHD4
LEFT COIL

Fig. 29 - Sensor Mounting Location

A11076

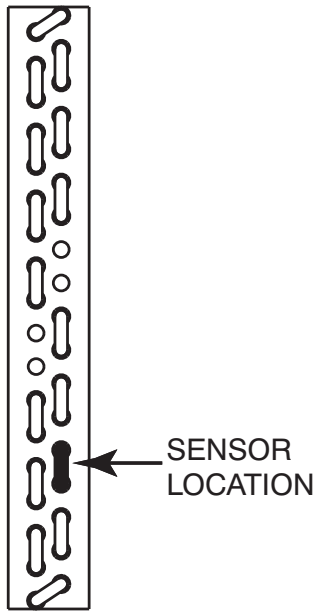

RETURN BEND END
WITHOUT HEADERS

UNIT SIZE 42
48VT-A 677C--A
50VT-A 607C--A PHD4

LEFT COIL

Fig. 30 - Sensor Mounting Location

A11077

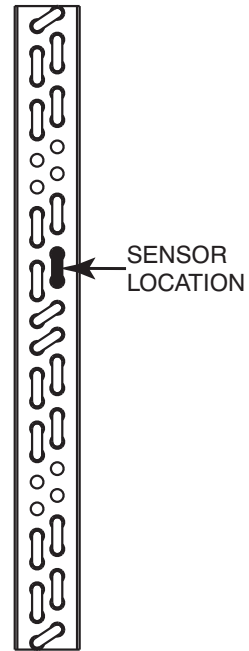

RETURN BEND END
WITHOUT HEADERS

UNIT SIZE 60
48VT-A 677C--A
50VT-A 607C--A PHD4

LEFT COIL

Fig. 32 - Sensor Mounting Location

A11079

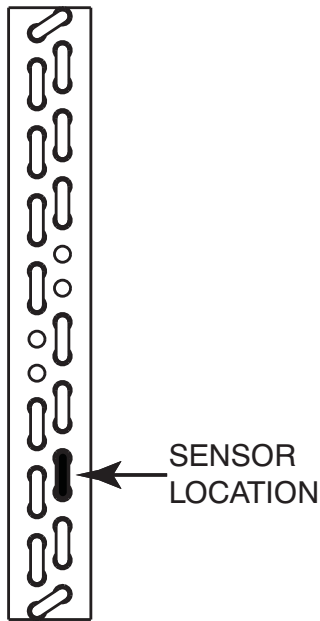

RETURN BEND END
WITHOUT HEADERS

UNIT SIZE 48
48VT-A 677C--A
50VT-A 607C--A PHD4

LEFT COIL

Fig. 31 - Sensor Mounting Location

A11078

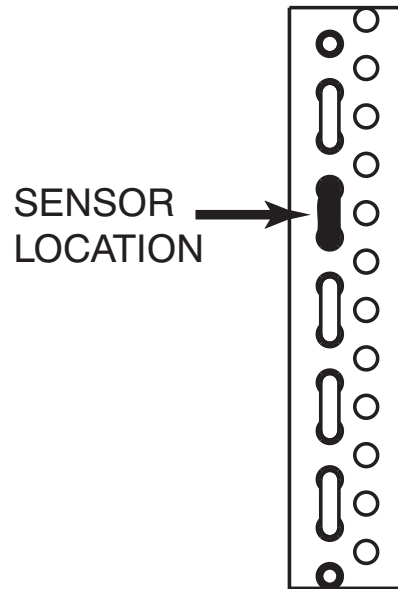

RETURN BEND END
WITHOUT HEADERS

UNIT SIZE 24
50GL PA4E

LEFT COIL

Fig. 33 - Sensor Mounting Location

A11050

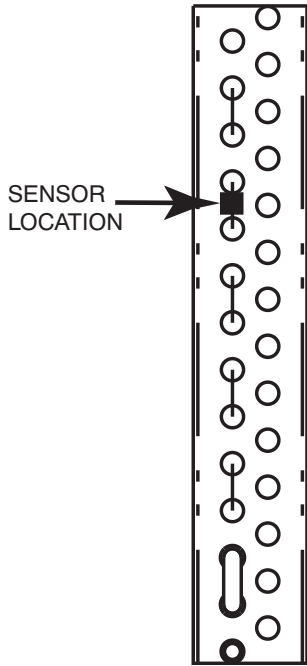

RETURN BEND END
UNIT SIZE 30
50GL PA4E
LEFT COIL

Fig. 34 - Sensor Mounting Location

A11051

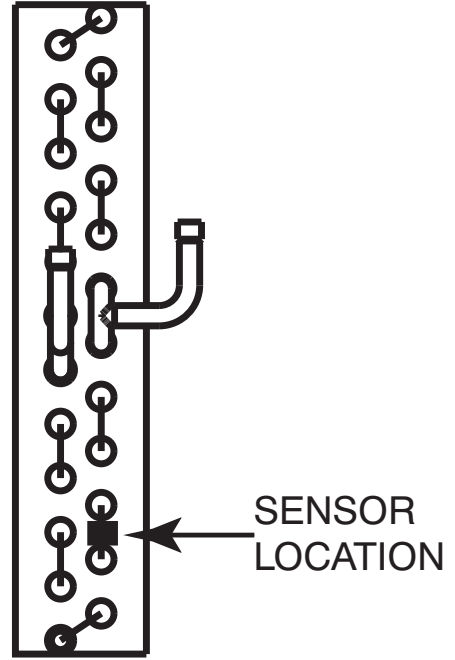

RETURN BEND END
UNIT SIZE 48
50GL PA4E
LEFT COIL

Fig. 36 - Sensor Mounting Location

A11053

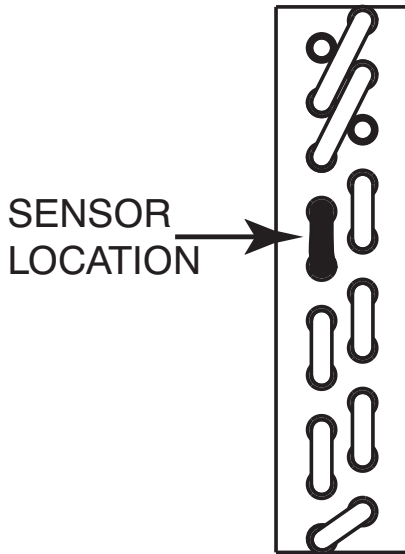

RETURN BEND END
WITHOUT HEADERS
UNIT SIZE 36
50GL PA4E
LEFT COIL

Fig. 35 - Sensor Mounting Location

A11052

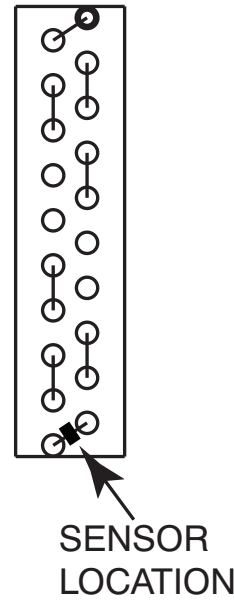

RETURN BEND END
UNIT SIZE 24
50JZ PH4E
LEFT COIL

Fig. 37 - Sensor Mounting Location

A11054

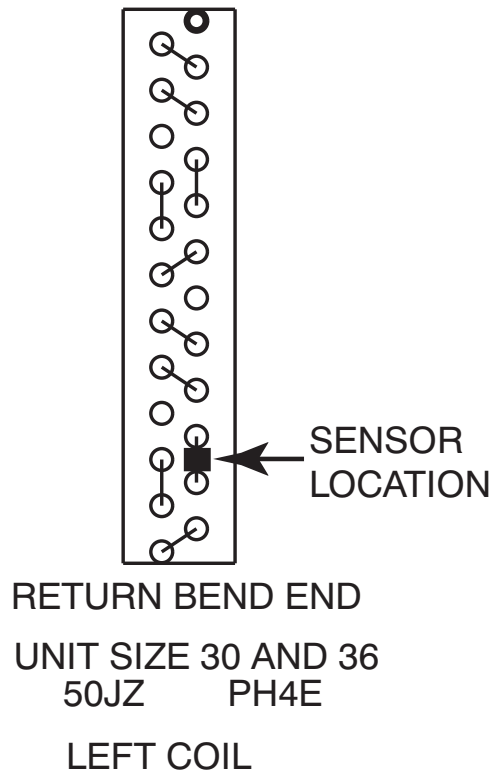

A11055

Fig. 38 - Sensor Mounting Location

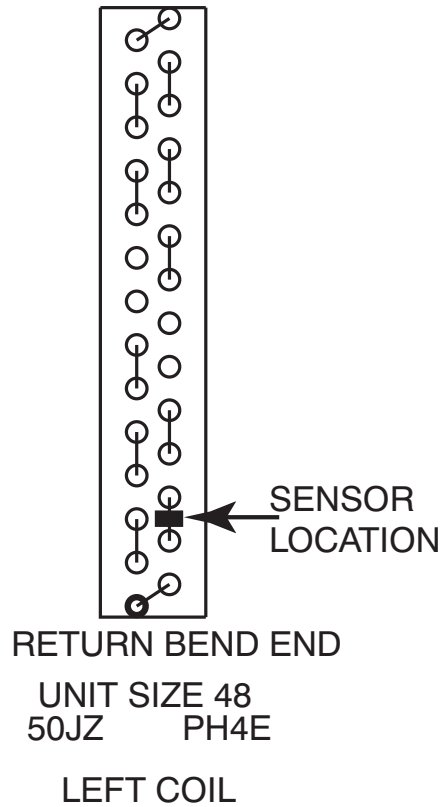

A11056

Fig. 39 - Sensor Mounting Location

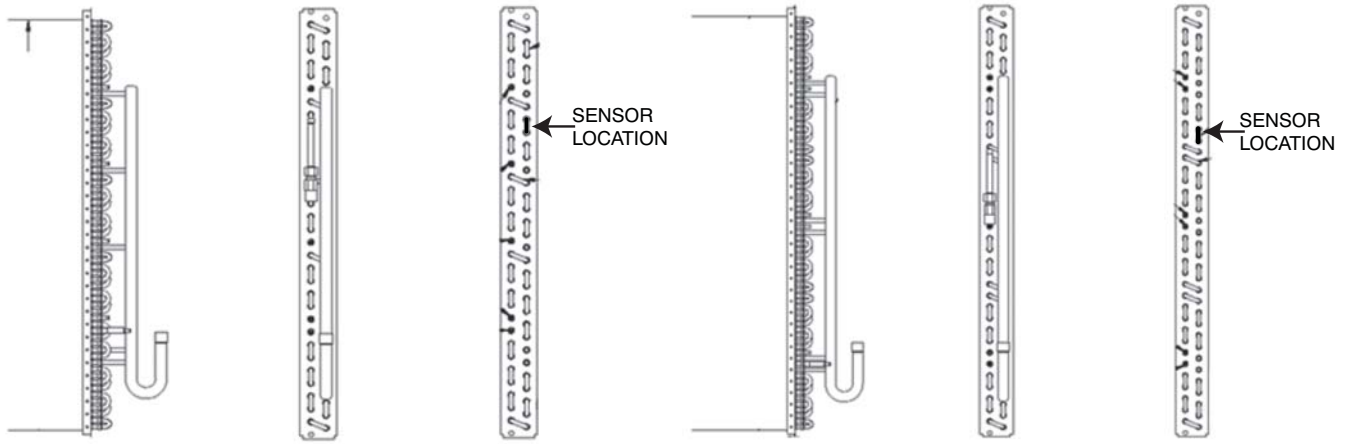

UNIT SIZE 024-030
50ZHB PHJ3 PH3Z WJH3

UNIT SIZE 036
50ZHB PHJ3 PH3Z WJH3

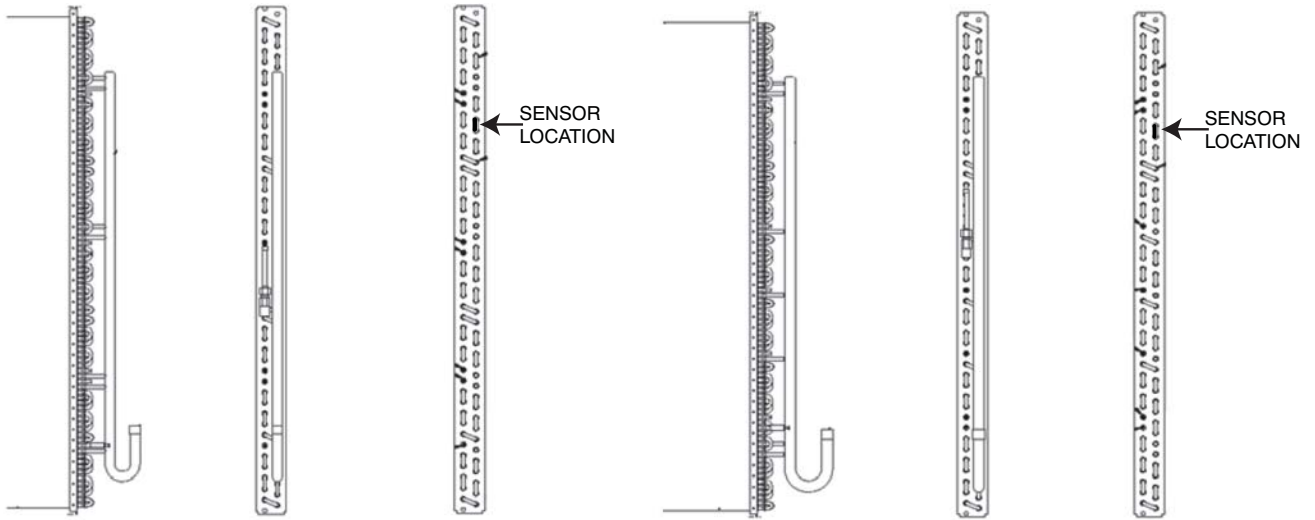

UNIT SIZE 042
50ZHB PHJ3 PH3Z WJH3

UNIT SIZE 048
50ZHB PHJ3 PH3Z WJH3

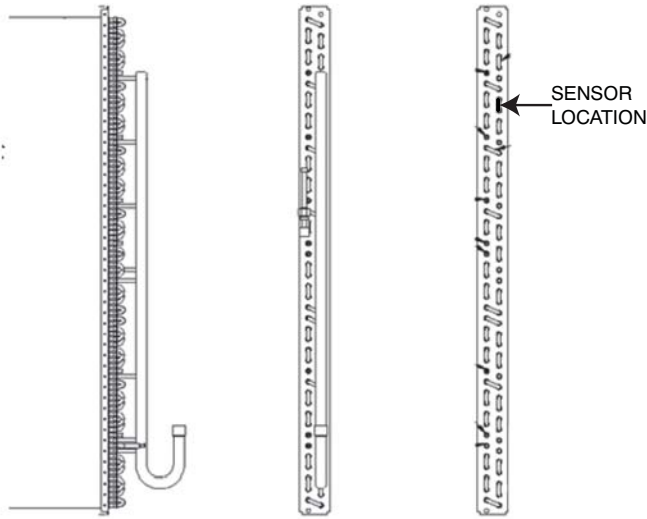

UNIT SIZE 060
50ZHB PHJ3 PH3Z WJH3

Fig. 40 - Sensor Mounting Location

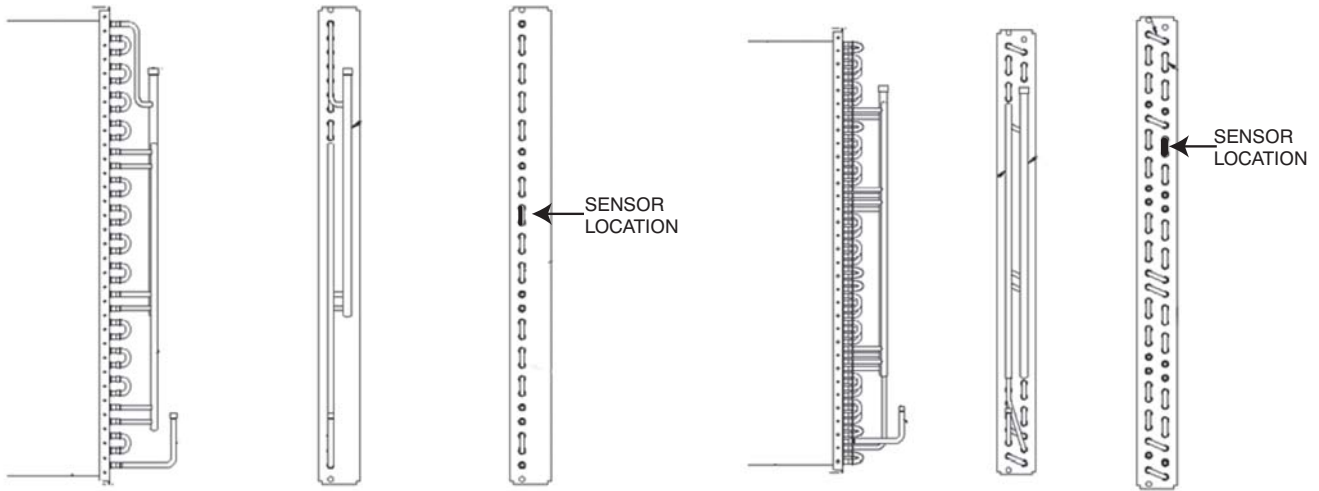

UNIT SIZE 024-030
50ZPB PAJ3 PA3Z WJA3

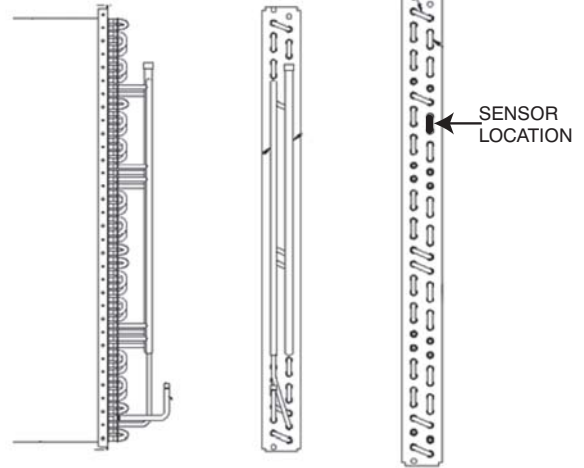

UNIT SIZE 036
50ZPB PAJ3 PA3Z WJA3

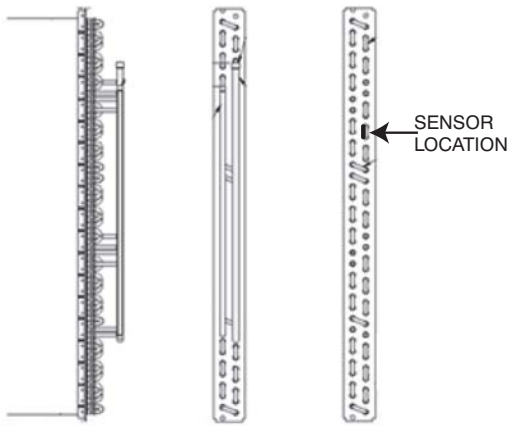

UNIT SIZE 042
50ZPB PAJ3 PA3Z WJA3

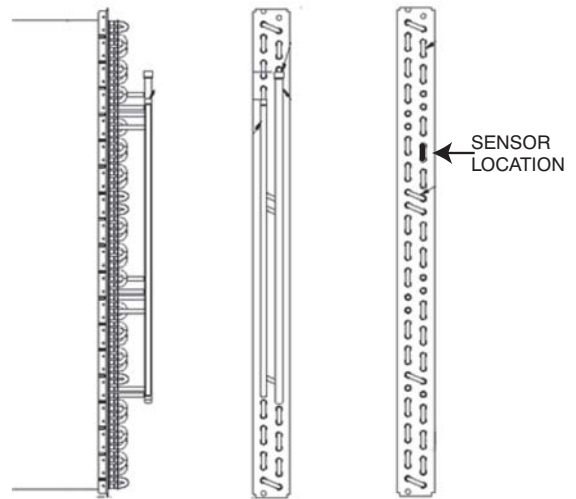

UNIT SIZE 048
50ZPB PAJ3 PA3Z WJA3

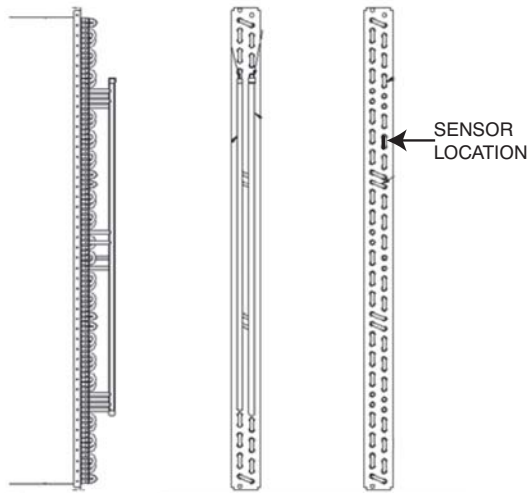

UNIT SIZE 060
50ZPB PAJ3 PA3Z WJA3

Fig. 41 - Sensor Mounting Location

