

INSTALLATION INSTRUCTIONS

R-410A Split System Air Conditioner

C4A3, H4A3, T4A3, CXA6, HXA6, TXA6

These instructions must be read and understood completely before attempting installation.

IMPORTANT: Effective January 1, 2015, all split system and packaged air conditioners must be installed pursuant to applicable regional efficiency standards issued by the Department of Energy.

SAFETY CONSIDERATIONS

Improper installation, adjustment, alteration, service, maintenance, or use can cause explosion, fire, electrical shock, or other conditions which may cause death, personal injury, or property damage. Consult a qualified installer, service agency, or your distributor or branch for information or assistance. The qualified installer or agency must use factory-authorized kits or accessories when modifying this product. Refer to the individual instructions packaged with the kits or accessories when installing.

Follow all safety codes. Wear safety glasses, protective clothing, and work gloves. Use quenching cloth for brazing operations. Have fire extinguisher available. Read these instructions thoroughly and follow all warnings or cautions included in literature and attached to the unit. Consult local building codes and current editions of the National Electrical Code (NEC) NFPA 70. In Canada, refer to current editions of the Canadian electrical code CSA 22.1.

Recognize safety information. This is the safety-alert symbol

 When you see this symbol on the unit and in instructions or manuals, be alert to the potential for personal injury. Understand these signal words; DANGER, WARNING, and CAUTION. These words are used with the safety-alert symbol. DANGER identifies the most serious hazards which **will** result in severe personal injury or death. WARNING signifies hazards which **could** result in personal injury or death. CAUTION is used to identify unsafe practices which **would** result in minor personal injury or product and property damage. NOTE is used to highlight suggestions which **will** result in enhanced installation, reliability, or operation.



WARNING

ELECTRICAL SHOCK HAZARD

Failure to follow this warning could result in personal injury or death.

Before installing, modifying, or servicing system, main electrical disconnect switch must be in the OFF position. There may be more than 1 disconnect switch. Lock out and tag switch with a suitable warning label.



WARNING

EXPLOSION HAZARD

Failure to follow this warning could result in death, serious personal injury, and/or property damage.

Never use air or gases containing oxygen for leak testing or operating refrigerant compressors. Pressurized mixtures of air or gases containing oxygen can lead to an explosion.



INSPECT NEW UNIT

After uncrating unit, inspect thoroughly for hidden damage. If damage is found, notify the transportation company immediately and file a concealed damage claim.



CAUTION

PROPERTY DAMAGE HAZARD

Failure to follow this caution may result in property damage

R-410A systems operate at higher pressures than R-22 systems. When working with R-410A systems, use only service equipment and replacement components specifically rated or approved for R-410A service.



CAUTION

CUT HAZARD

Failure to follow this caution may result in personal injury.

Sheet metal parts may have sharp edges or burrs. Use care and wear appropriate protective clothing and gloves when handling parts.

LOCATION

Check local codes for regulations concerning zoning, noise, platforms, and other issues.

Locate unit away from fresh air intakes, vents, or bedroom windows. Noise may carry into the openings and disturb people inside.

Locate unit in a well drained area, or support unit high enough so that water runoff will not enter the unit.

Locate unit away from areas where heat, lint, or exhaust fumes will be discharged onto unit (as from dryer vents).

Locate unit away from recessed or confined areas where recirculation of discharge air may occur (refer to CLEARANCES section of this document).

Roof-top installation is acceptable providing the roof will support the unit and provisions are made for water drainage and noise/vibration dampening.

NOTE: Roof mounted units exposed to wind may require wind baffles. Consult the manufacturer for additional information.

CLEARANCES

When installing, allow sufficient space for airflow clearance, wiring, refrigerant piping, and service. Allow 24 in. (610 mm) clearance to service end of unit and 48 in. (1219.2 mm) above unit. For proper airflow, a 6 in. (152.4 mm) clearance on one side of unit and 12 in. (304.8 mm) on all remaining sides must be maintained. Maintain a distance of 24 in. (609.6 mm) between units or 18 in. (457.2 mm) if no overhang within 12 ft. (3.66 m). Position so water, snow, or ice from roof or eaves cannot fall directly on unit.

Operating Ambient

The minimum outdoor operating ambient in cooling mode without accessory is 55°F (12.78°C), and the maximum outdoor operating ambient in cooling mode is 115°F (46.11°C).

UNIT SUPPORT

NOTE: Unit must be level ± 2 degrees [a $\frac{3}{8}$ inch rise or fall per foot of run (10 mm rise or fall per 305 mm of run)] or compressor may not function properly.

A. GROUND LEVEL INSTALLATION

The unit must be level and supported above grade by beams, platform, or a pad. Platform or pad can be of open or solid construction but should be of permanent

materials such as concrete, bricks, blocks, steel, or pressure-treated timbers approved for ground contact. Soil conditions must be considered so that the platform or pad does not shift or settle and leave the unit partially supported. Minimum pad dimensions are shown in Figure 1.

If beams or an open platform are used for support, it is recommended that the soil be treated or area be graveled to reduce the growth of grasses and weeds.

To minimize vibration or noise transmission, it is recommended that supports not be in contact with the building structure. However, slabs on grade constructions with an extended pad are normally acceptable.

B. ROOF TOP INSTALLATION

This type of installation is not recommended on wood frame structures where low noise levels are required.

Supporting structure or platform for the unit must be level. If installation is on a flat roof, locate unit minimum 6 inches (152 mm) above roof level.

Place the unit over one or more load bearing walls. If there are several units, mount them on platforms that are self-supporting and span several load bearing walls. These suggestions are to minimize noise and vibration transmission through the structure. If the structure is a home or apartment, avoid locating the unit over bedrooms or study.

NOTE: When unit is to be installed on a bonded guaranteed roof, a release must be obtained from the building owner to free the installer from all liabilities.

C. FASTENING UNIT DOWN

If conditions or local codes require the unit be attached in place, remove the knockouts in the base pan and install tie down bolts through the holes (refer to Figure 1).

Contact local distributor for hurricane hold-down details and the P.E. (Professional Engineer) certification, when required.



CAUTION

PROPERTY DAMAGE HAZARD

Failure to follow this caution may result in property damage.

Inadequate unit support may cause excessive vibration, noise, and/or stress on the refrigerant lines, leading to refrigerant line failure.

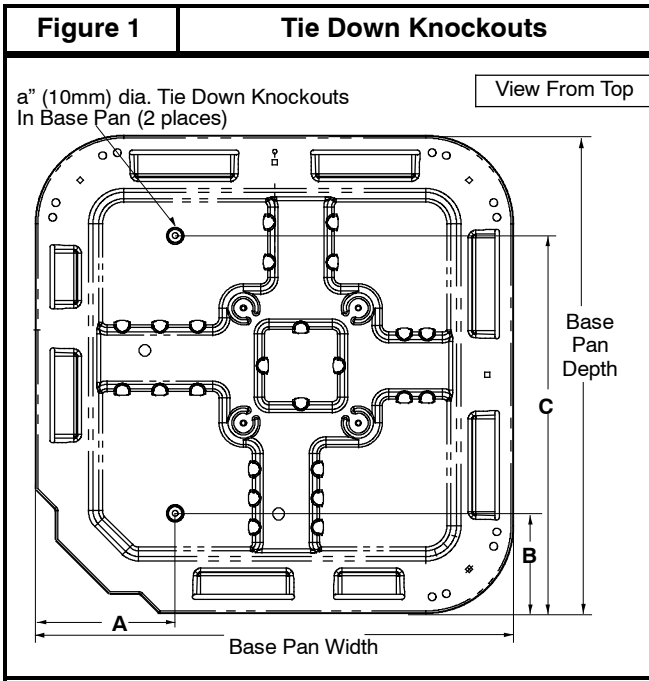

Inches (mm)				
Base Pan Width x Depth	Tie Down Knockouts			Minimum Mounting Pad Dimensions
	A	B	C	
23 x 23 (584 x 584)	7-3/4 (197)	4-7/16 (113)	18 (457)	23 x 23 (584 x 584)
25-11/16 x 25-11/16 (652 x 652)	9-1/16 (230)	4-7/16 (113)	21-1/4 (540)	26 x 26 (660 x 660)
31-1/8 x 31-1/8 (791 x 791)	9-1/16 (230)	6-1/2 (165)	24-5/8 (625)	31-1/2 x 31-1/2 (800 x 800)
34-15/16 x 34-15/16 (887 x 887)	9-1/16 (230)	6-1/2 (165)	28-7/16 (722)	35 x 35 (889 x 889)

REFRIGERATION SYSTEM

A. COMPONENT MATCHES

Check to see that the proper system components are in place, especially the indoor coil.

R-410A outdoor units can only be used with R-410A specific indoor coils. If there is a refrigerant mis-match, consult the indoor coil manufacturer to determine if a refrigerant conversion kit is available for the indoor coil.

This outdoor unit is designed for use only with indoor coils that utilize a TXV refrigerant metering device or Piston with Teflon ring metering device. If any other type of metering device is installed on the indoor coil, consult the indoor coil manufacturer to determine if a TXV conversion kit is available.

Installing with TXV

When installing a TXV on an indoor coil, follow the instructions provided with the new TXV.

A typical TXV installation is shown in Figure 2.

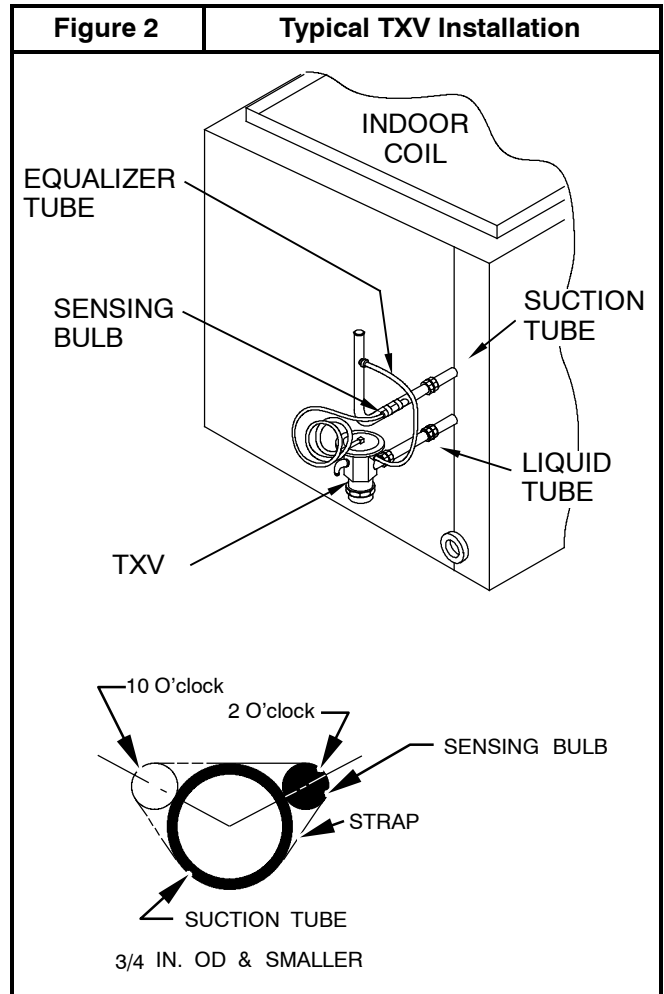

Installing with Indoor Piston - cooling operation.

Check piston size shipped with indoor unit to see if it matches required indoor piston size. If it **does not** match, replace indoor piston with the correct piston size.

NOTE: Correct pistons are shipped with select outdoor units in the accessory bag and are only for use in certain qualified and approved fancoils, i.e. FEM4P. (See Product Specifications for list of approved fancoils that use accessory piston.)

The piston included with the FMA4P* and FM(C,U)4P* fancoils are unique to those products and **cannot** be replaced with the piston shipped with the outdoor unit. Refer to the AHRI Directory to check if your combination can use a piston or requires an accessory TXV.

See Figure 3.

When changing indoor piston, use a back-up wrench. Hand tighten hex nut, then tighten with wrench 1/2 turn. Do not exceed 30 ft-lbs. The indoor piston contains a Teflon ring (or seal) which is used to seat against the inside of distributor body, and must be installed properly to ensure proper seating in the direction for cooling operation.

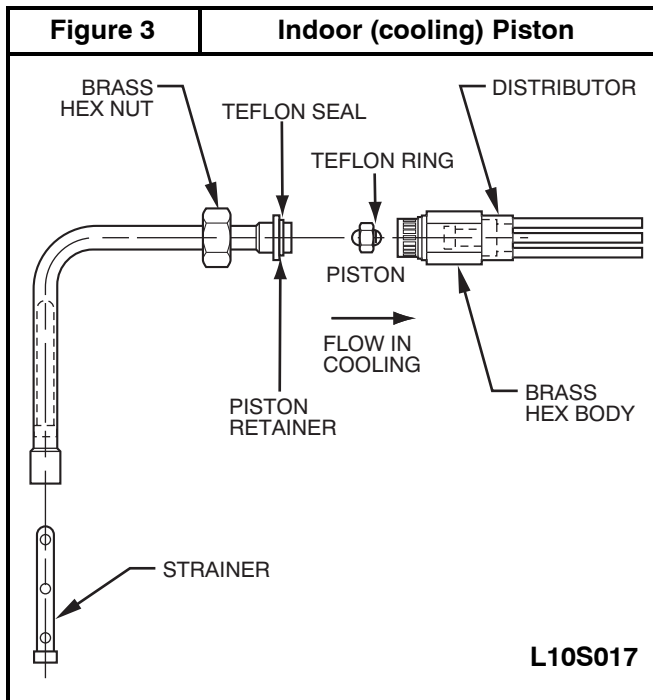

Be extra careful when bending refrigeration tubing. Tubing can “kink” easily, and if this occurs, the entire length of tubing must be replaced.

⚠ WARNING

PERSONAL INJURY HAZARD
 Failure to relieve system pressure could result in personal injury and/or death.

Relieve pressure and recover all refrigerant before servicing existing equipment, and before final unit disposal. Use all service ports and open all flow-control devices, including solenoid valves.

B. REFRIGERANT LINE SETS

The refrigerant line set must be properly sized to assure maximum efficiency and proper oil circulation.

Refer to Product Specifications and Long Line Applications Guideline for line set sizing.

NOTE: Total line set length must not exceed 200 feet (61 m).

A crankcase heater must be used when the refrigerant line length exceeds 80 feet (24.4 m).

If outdoor unit is more than 10 feet (3 m) higher than the indoor coil, refer to the Long Line Applications Guideline for instructions.

When the outdoor unit is higher than the indoor coil, the vertical separation must not exceed 100 feet (30 m).

When the outdoor unit is lower than the indoor coil, the vertical separation must not exceed 50 feet (15.2 m).

If it is necessary to add refrigerant line in the field, use dehydrated or dry, sealed, deoxidized, copper refrigeration tubing. Do not use copper water pipe.

Do not remove rubber plugs or caps from copper tubing until connections are ready to be made.

C. ROUTING AND SUSPENDING REFRIGERANT LINES

Run refrigerant lines as straight and direct as possible, avoiding unnecessary bends and turns. Always insulate the entire suction line. Both lines should be insulated when routed through an attic or when routed through an underground raceway.

When routing refrigerant lines through a foundation or wall, do not allow refrigerant lines to come in direct contact with the building structure. Make openings large enough so that lines can be wrapped with extra insulation. Fill all gaps with RTV caulk. This will prevent noise transmission between the tubing and the foundation or wall.

Along floor or ceiling joists, suspend refrigerant lines so that they do not contact the building structure, water pipes, or ductwork. Use insulated or suspension type hangers. Metal straps must be at least 1” (25 mm) wide to avoid cutting into the tube insulation. Keep the liquid and suction lines separate. Refer to Figure 4.

⚠ CAUTION

UNIT OPERATION HAZARD
 Failure to follow this caution may result in improper product operation.

Do not leave system open to atmosphere any longer than absolutely required for installation. Internal system components - especially refrigerant oils - are extremely susceptible to moisture contamination. Keep ends of tubing sealed during installation until the last possible moment.

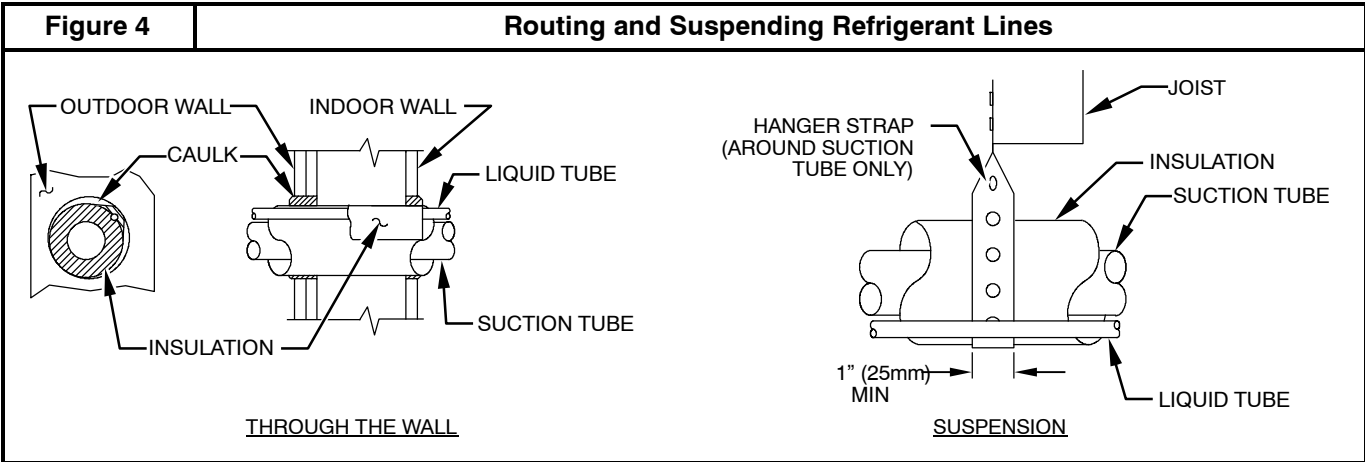

⚠ CAUTION

UNIT OPERATION HAZARD
 Failure to follow this caution may result in improper product operation.

Do not bury more than 36" (1m) of line set underground. Refrigerant may migrate to cooler buried section during extended periods of unit shut-down, causing refrigerant slugging and possible compressor damage at start-up.

If ANY section of the line set is buried underground, provide a minimum 6" (152mm) vertical rise at the service valve.

D. OUTDOOR UNIT HIGHER THAN INDOOR UNIT
 Proper oil return to the compressor should be maintained with suction gas velocity. If velocities drop below 1500 fpm (feet per minute), oil return will be decreased. To maintain suction gas velocity, do not upsize vertical suction risers.

E. LIQUID LINE FILTER-DRIER
 Outdoor units are shipped with an appropriate filter- drier for installation in the liquid line. Leave the plugs in the tube ends until the filter- drier is installed. The optimal location for the filter- drier is close to the indoor coil. Install the filter- drier with the arrow pointing towards the indoor coil. Refer to Figure 5.

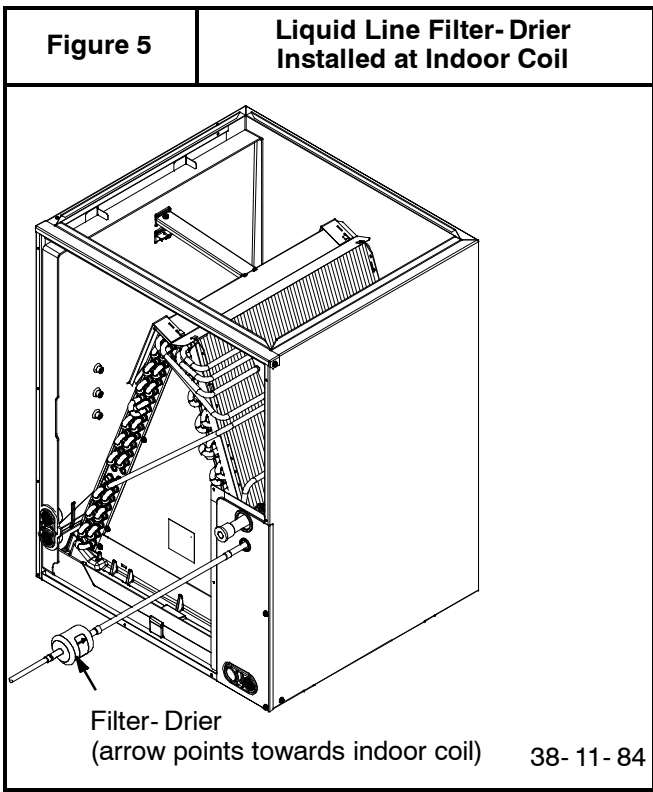

F. SERVICE VALVES
 Service valves are closed and tube stubs are plugged from the factory. Outdoor units are shipped with a refrigerant charge sealed in the unit. Leave the service valves closed until all other refrigerant system work is complete or the charge will be lost. Leave the plugs in place until line set tubing is ready to be inserted. Service valve bodies are brass and tube stubs are copper.

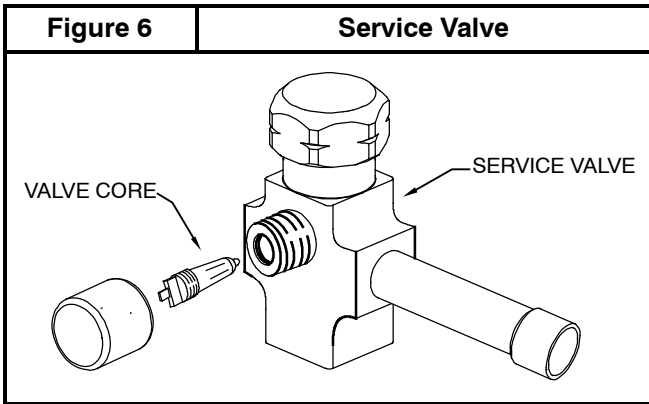

G. BRAZING CONNECTIONS

NOTE: Remove valve core from schrader port on both Service Valves BEFORE brazing. This helps prevent overheating and damage to valve seals (refer to Figure 6). Replace valve core when brazing is completed.

⚠ WARNING

FIRE HAZARD

Failure to remove refrigerant and oil charge before brazing could result in personal injury, death, and/or property damage.

Refrigerant and oil mixture could ignite and burn as it escapes and contacts brazing torch. Make sure the refrigerant charge is properly removed from both the high and low sides of the system before brazing any component or lines.

Clean line set tube ends with emery cloth or steel brush. Remove any grit or debris.

Insert line set tube ends into service valve tube stubs.

Apply heat absorbing paste or heat sink product between service valve and joint. Wrap service valves with a heat sinking material such as a wet cloth.

Braze joints using a Sil-Fos or Phos-copper alloy.

⚠ CAUTION

PRODUCT DAMAGE HAZARD

Failure to follow this caution may result in product damage.

Braze with Sil-Fos or Phos-copper alloy on copper-to-copper joints and wrap a wet cloth around rear of fitting to prevent damage to TXV.

H. EVACUATING LINE SET AND INDOOR COIL

The unit is shipped with a factory refrigerant charge. The liquid line and suction line service valves have been closed after final testing at the factory. Do not disturb these valves until the line set and indoor coil have been evacuated and leak checked, or the charge in the unit may be lost.

NOTE: Do not use any portion of the factory charge for purging or leak testing. The factory charge is for filling the system only after a complete evacuation and leak check has been performed.

⚠ CAUTION

PRODUCT DAMAGE HAZARD

Failure to follow this caution may result in product damage.

Never use the outdoor unit compressor as a vacuum pump. Doing so may damage the compressor.

Line set and indoor coil should be evacuated using the recommended deep vacuum method of 500 microns. If deep vacuum equipment is not available, the alternate triple evacuation method may be used by following the specified procedure.

If vacuum must be interrupted during the evacuation procedure, always break vacuum with dry nitrogen.

Deep Vacuum Method

The deep vacuum method requires a vacuum pump capable of pulling a vacuum to 500 microns and a vacuum gauge capable of accurately measuring this vacuum level. The deep vacuum method is the most positive way of assuring a system is free of air and water.

Watch the vacuum gauge as the system is pulling down. The response of the gauge is an indicator of the condition of the system (refer to Figure 7).

With no leaks in the system, allow the vacuum pump to run for 30 minutes minimum at the deep vacuum level.

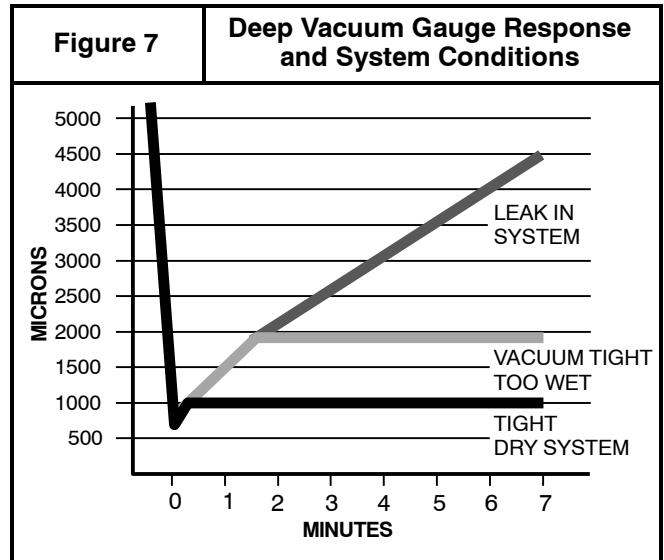

Triple Evacuation Method

The triple evacuation method should only be used when system does not contain any water in liquid form and vacuum pump is only capable of pulling down to 28 inches of mercury (711mm Hg). Refer to Figure 8 and proceed as follows:

1. Pull system down to 28 inches of mercury (711mm Hg) and allow pump to continue operating for an additional 15 minutes.
2. Close manifold valves or valve at vacuum pump and shut off vacuum pump.
3. Connect a nitrogen cylinder and regulator to system and fill with nitrogen until system pressure is 2 psig.

4. Close nitrogen valve and allow system to stand for 1 hour. During this time, dry nitrogen will diffuse throughout the system absorbing moisture.
5. Repeat this procedure as indicated in Figure 8.
6. After the final evacuate sequence, confirm there are no leaks in the system. If a leak is found, repeat the entire process after repair is made.

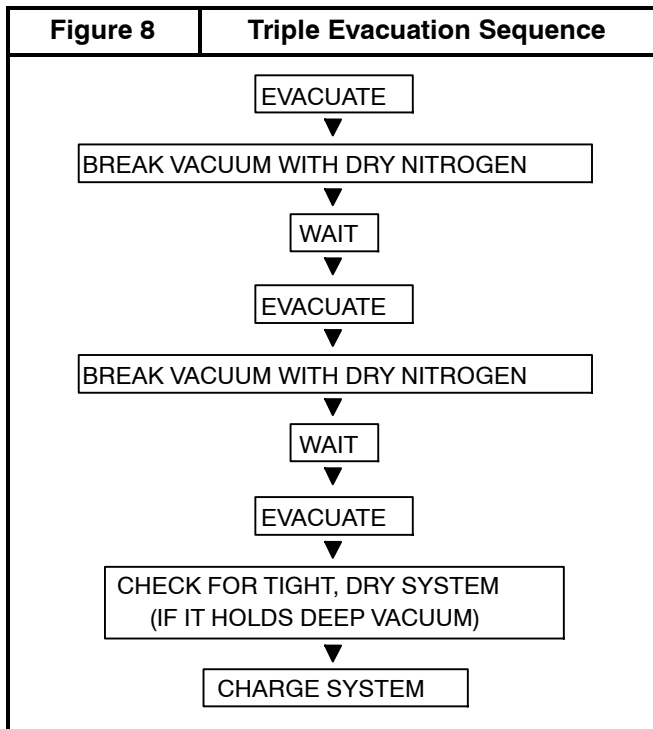

I. OPENING SERVICE VALVES

Outdoor units are shipped with a refrigerant charge sealed in the unit. Opening the service valves releases this charge into the system.

NOTE: Open the Suction service valve first. If the Liquid service valve is opened first, oil from the compressor may be drawn into the indoor coil TXV, restricting refrigerant flow and affecting operation of the system.

Remove Suction service valve cap and insert a hex wrench into the valve stem. Hold the valve body steady with an end-wrench and back out the stem by turning the hex wrench counterclockwise. Turn the stem until it just contacts the rolled lip of the valve body.

After the refrigerant charge has bled into the system, open the Liquid service valve.

NOTE: These are not back-seating valves. It is not necessary to force the stem tightly against the rolled lip.

The service valve cap is a primary seal for the valve and must be properly tightened to prevent leaks. Make sure cap is clean and apply refrigerant oil to threads and sealing surface on inside of cap.

Tighten cap finger tight and then tighten additional 6 of a turn (1 wrench flat) to properly seat the sealing surfaces.

J. GAUGE PORTS

Check for leaks at the schrader ports and tighten valve cores if necessary. Install plastic caps finger tight.

ELECTRICAL WIRING

⚠ **WARNING**

ELECTRICAL SHOCK HAZARD

Failure to turn off the main (remote) electrical disconnect device could result in personal injury or death.

Before installing, modifying or servicing system, turn OFF the main (remote) electrical disconnect device. There may be more than one disconnect device.

The supply voltage must be 208/230 volts (197 volt minimum to 253 volts maximum) 60 Hz single phase.

Outdoor units are approved for use with copper conductors only. Do not use aluminum wire.

Refer to unit rating plate for minimum circuit ampacity and circuit protection requirements.

Grounding

Permanently ground unit in accordance with the National Electrical Code and local codes or ordinances. Use a copper conductor of the correct size from the grounding lug in control box to a grounded connection in the service panel or a properly driven and electrically grounded ground rod.

Wiring Connections

Make all outdoor electrical supply (Line Voltage) connections with raintight conduit and fittings. Most codes require a disconnect switch outdoors within sight of the unit. Consult local codes for special requirements.

Route electrical supply (Line Voltage) wiring through knockout hole in bottom of Control Box. Connect wires to Contactor and Ground Lug according to Wiring Diagram on unit. Refer to Figure 9.

Route thermostat wiring through rubber grommet in bottom of Control Box. Low voltage lead wires are provided in the control box for connection to thermostat wires (use wire nuts). Refer to Wiring Diagram on unit and Figure 10 for low voltage wiring examples.

NOTE: Use No. 18 AWG (American Wire Gage) color-coded, insulated (35 °C minimum) wire. If thermostat is located more than 100 feet (31 m) from unit as measured along the control voltage wires, use No. 16 AWG color-coded wires to avoid excessive voltage drop.

NOTE: Some models are factory equipped with Comfort Alert™ Diagnostics device. If Comfort Alert is used as a field installed option, then a hot bundle must be run for proper connection.

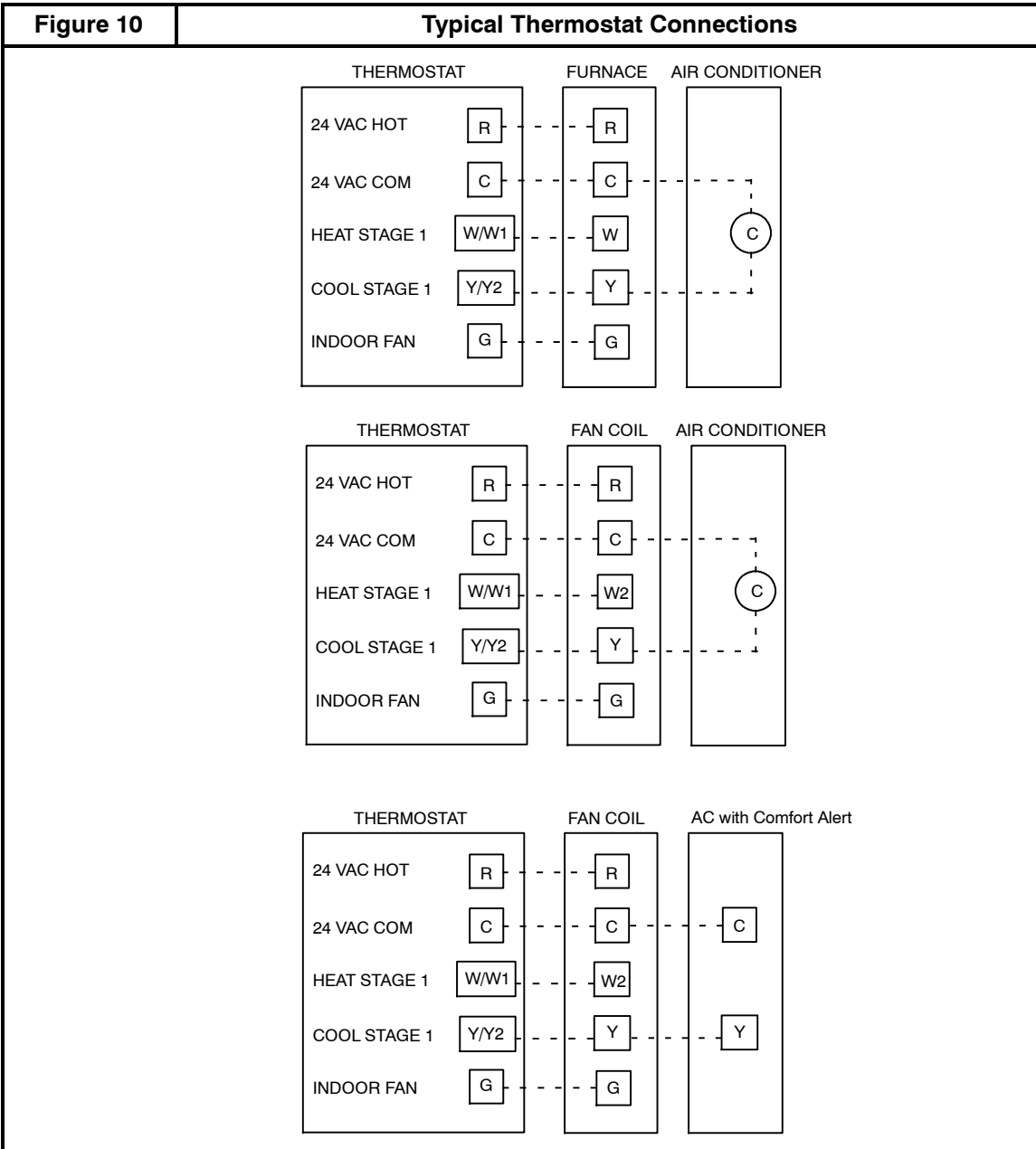
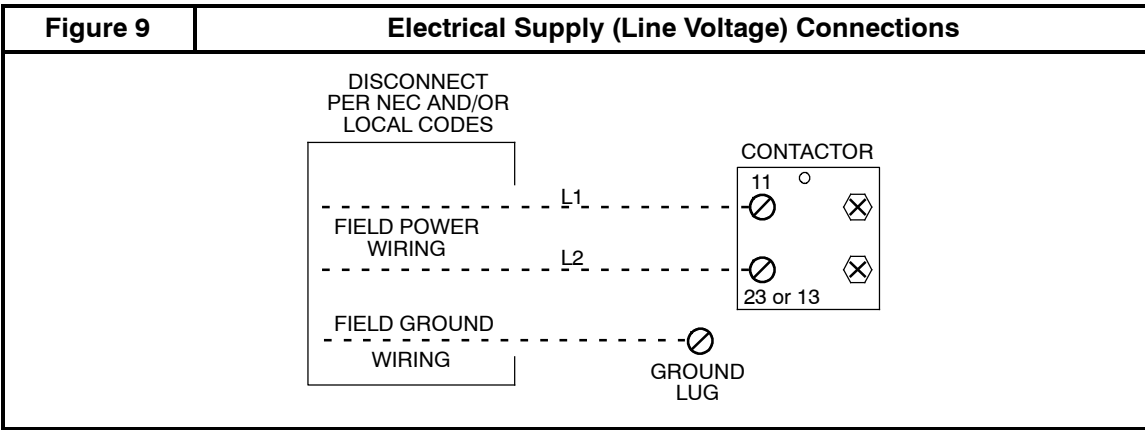

START-UP PROCEDURE

1. Set indoor thermostat selector switch to OFF.
2. Turn ON all electrical disconnect devices.
3. If unit has a crankcase heater, energize the heater and wait 24 hours before proceeding.
4. Set indoor thermostat at desired temperature. Be sure setpoint is below indoor ambient temperature or thermostat will not call for cooling.
5. Set indoor thermostat selector switch to COOL. Operate unit for minimum 15 minutes, then check the system refrigerant charge.

REFRIGERANT CHARGE

Factory charge amount and desired subcooling are shown on unit rating plate. Charging method is shown on information plate inside unit.

For TXV, use subcooling method.

For Piston, use superheat method.

To properly check or adjust charge, conditions must be favorable for subcooling or superheat charging. Favorable conditions exist when the outdoor temperature is between 70°F and 100°F (21°C and 38°C), and the indoor temperature is between 70°F and 80°F (21°C and 27°C). Follow the procedure below.

Unit is factory charged for 15 feet (4.6 m) of lineset. Adjust charge by adding or removing 0.6 oz/ft (17 g/mm) of 3/8 liquid line above or below 15 feet (4.6 m) respectively.

For standard refrigerant line lengths 80 feet (24.4 m) or less, allow system to operate in cooling mode at least 15 minutes. If conditions are favorable, check system charge by super heat method for fixed metering device and subcooling method for TXV. If any adjustment is necessary, adjust charge slowly and allow system to operate for 15 minutes to stabilize before declaring a properly charged system.

If the indoor temperature is above 80°F (27°C), and the outdoor temperature is in the favorable range, adjust system charge by weight based on line length and allow the indoor temperature to drop to 80°F (27°C) before attempting to check system charge by subcooling method as described above.

If the indoor temperature is below 70°F (21°C), or the outdoor temperature is not in the favorable range, adjust charge for line set length above or below 15 feet (4.6 m) only. Charge level should then be appropriate for the system to achieve rated capacity. The charge level could then be checked at another time when the both indoor and outdoor temperatures are in a more favorable range.

NOTE: If line length is beyond 80 feet (24.4 m) or greater than 35 feet (10.7 m) vertical separation, See Long Line Guideline for special charging requirements.

A. UNITS WITH COOLING MODE TXV

Units installed with cooling mode TXV require charging by the subcooling method.

1. Operate unit a minimum of 15 minutes before checking charge.

NOTE: If outdoor unit has a 2-speed fan motor, motor will operate in low speed when outdoor ambient temperature is below 82°F. Pull one of the yellow low voltage wires off the fan control and the unit will default to high speed fan for servicing. Reconnect wire after servicing.

2. Measure liquid service valve pressure by attaching an accurate gage to service port.
3. Measure liquid line temperature by attaching an accurate thermistor type or electronic thermometer to liquid line near outdoor coil.
4. Refer to unit rating plate for required subcooling temperature.
5. Refer to Figure 13. Find the point where required subcooling temperature intersects measured liquid service valve pressure.
6. To obtain required subcooling temperature at a specific liquid line pressure, add refrigerant if liquid line temperature is higher than indicated or reclaim refrigerant if temperature is lower. Allow a tolerance of $\pm 3^{\circ}\text{F}$ ($\pm 1.7^{\circ}\text{C}$).

B. UNITS WITH INDOOR PISTON

Units installed with indoor pistons require charging by the superheat method.

The following procedure is valid when indoor airflow is within ± 21 percent of its rated CFM.

1. Operate unit a minimum of 15 minutes before checking charge.
2. Measure suction pressure by attaching an accurate gage to suction valve service port.
3. Measure suction temperature by attaching an accurate thermistor type or electronic thermometer to suction line at service valve.
4. Measure outdoor air dry-bulb temperature with thermometer.
5. Measure indoor air (entering indoor coil) wet-bulb temperature with a sling psychrometer.
6. Find outdoor temperature and evaporator entering air wet-bulb temperature. At this intersection, note superheat. Where a dash (- -) appears on the table, do not attempt to charge system under these conditions or refrigerant slugging may occur. Charge must be weighted in, adding or removing 0.6 oz/ft of 3/8 liquid line above or below 15 feet (4.6 m) respectively.
7. Find superheat temperature (from #6 above) and suction pressure. At this intersection, note suction line temperature.
8. If unit has a higher suction line temperature than charted temperature, add refrigerant until charted temperature is reached.
9. If unit has a lower suction line temperature than charted temperature, reclaim refrigerant until charted temperature is reached.
10. When adding refrigerant, charge in liquid form into suction service port using a flow-restricting device.
11. If outdoor air temperature or pressure at suction valve changes, charge to new suction line temperature indicated on chart.

12. Optimum performance will be achieved when the operating charge produces 10°F suction superheat at suction service valve with 95°F (35°C) outdoor ambient and 80°F (27°C) dry bulb (67°F / 19°C) wet bulb indoor temperature (DOE “A” test conditions) at rated airflow.

Figure 11 Outdoor Temp	SUPERHEAT CHARGING TABLE (SUPERHEAT °F AT LOW-SIDE SERVICE PORT)													SUPERHEAT CHARGING TABLE (SUPERHEAT °C AT LOW-SIDE SERVICE PORT)															
	EVAPORATOR ENTERING AIR °F AT WB													EVAPORATOR ENTERING AIR °C AT WB															
	°F = Fahrenheit													°C = Celsius															
°F	50	52	54	56	58	60	62	64	66	68	70	72	74	76	°C	10	11	12	13	14	16	17	18	19	20	21	22	23	24
55	9	12	14	17	20	23	26	29	32	35	37	40	42	45	13	5	7	8	9	11	13	14	16	18	19	21	22	23	25
60	7	10	12	15	18	21	24	27	30	33	35	38	40	43	16	4	6	7	8	10	12	13	15	17	18	19	21	22	24
65	-	6	10	13	16	19	21	24	27	30	33	36	38	41	18	-	3	6	7	9	11	12	13	15	17	18	20	21	23
70	-	-	7	10	13	16	19	21	24	27	30	33	36	39	21	-	-	4	6	7	9	11	12	13	15	17	18	20	22
75	-	-	-	6	9	12	15	18	21	24	28	31	34	37	24	-	-	-	3	5	7	8	10	12	13	16	17	19	21
80	-	-	-	-	5	8	12	15	18	21	25	28	31	35	27	-	-	-	-	3	4	7	8	10	12	14	16	17	19
85	-	-	-	-	-	8	11	15	19	22	26	30	33	29	-	-	-	-	-	4	6	8	11	12	14	17	18		
90	-	-	-	-	-	5	9	13	16	20	24	27	31	32	-	-	-	-	-	3	5	7	9	11	13	15	17		
95	-	-	-	-	-	-	6	10	14	18	22	25	29	35	-	-	-	-	-	-	3	6	8	10	12	14	16		
100	-	-	-	-	-	-	8	12	15	20	23	27	38	-	-	-	-	-	-	-	4	7	8	11	13	15			
105	-	-	-	-	-	-	5	9	13	17	22	26	41	-	-	-	-	-	-	-	3	5	7	9	12	14			
110	-	-	-	-	-	-	6	11	15	20	25	43	-	-	-	-	-	-	-	-	3	6	8	11	14				
115	-	-	-	-	-	-	8	14	18	23	46	-	-	-	-	-	-	-	-	-	4	8	10	13					

*Optimum performance point, 95°F (35°C) outdoor ambient and (80°F / 27°C dry bulb), (67°F / 19°C wet bulb) indoor conditions. (DOE A Test Conditions)

Where a dash (-) appears do not attempt to charge system under these conditions or refrigerant slugging may occur. Charge must be weighed in.

Note: Superheat °F is at low- side service port. Allow a tolerance of ± 3°F (± 1.7°C)

Note: Indoor dry bulb between 70°F and 80°F (21°C and 27°C)

Figure 12 SUPER-HEAT TEMP F	SUCTION PRESSURE AT SERVICE PORT PSIG										SUPER-HEAT TEMP C	SUCTION PRESSURE AT SERVICE PORT kPA									
	108	112	117	121	126	131	139	141	146	743		774	805	836	869	902	957	971	1005		
	REQUIRED SUCTION TUBE TEMPERATURE °F (MEASURED AT LOW- SIDE SERVICE PORT)											REQUIRED SUCTION TUBE TEMPERATURE °C (MEASURED AT LOW- SIDE SERVICE PORT)									
0	35	37	39	41	43	45	47	49	51	0	2	3	4	5	6	7	8	9	11		
2	37	39	41	43	45	47	49	51	53	1	3	4	5	6	7	8	9	11	12		
4	39	41	43	45	47	49	51	53	55	2	4	5	6	7	8	9	11	12	13		
6	41	43	45	47	49	51	53	55	57	3	5	6	7	8	9	11	12	13	14		
8	43	45	47	49	51	53	55	57	59	4	6	7	8	9	11	12	13	14	15		
10	45	47	49	51	53	55	57	59	61	6	7	8	9	11	12	13	14	15	16		
12	47	49	51	53	55	57	59	61	63	7	8	9	11	12	13	14	15	16	17		
14	49	51	53	55	57	59	61	63	65	8	9	11	12	13	14	15	16	17	18		
16	51	53	55	57	59	61	63	65	67	9	11	12	13	14	15	16	17	18	19		
18	53	55	57	59	61	63	65	67	69	10	12	13	14	15	16	17	18	19	21		
20	55	57	59	61	63	65	67	69	71	11	13	14	15	16	17	18	19	21	22		
22	57	59	61	63	65	67	69	71	73	12	14	15	16	17	18	19	21	22	23		
24	59	61	63	65	67	69	71	73	75	13	15	16	17	18	19	21	22	23	24		
26	61	63	65	67	69	71	73	75	77	14	16	17	18	19	21	22	23	24	25		
28	63	65	67	69	71	73	75	77	79	16	17	18	19	21	22	23	24	25	26		
30	65	67	69	71	73	75	77	79	81	17	18	19	21	22	23	24	25	26	27		

Figure 13	Rating Plate (required) Subcooling Temperature °F (°C)											
	°F 6	(°C) 3	°F 8	(°C) 4	°F 10	(°C) 6	°F 12	(°C) 7	F 14	(°C) 8	F 16	(°C) 9
	R-410A Required Liquid Line Temperature °F (°C)											
251	78	26	76	24	74	23	72	22	70	21	68	20
259	80	27	78	26	76	24	74	23	72	22	70	21
266	82	28	80	27	78	26	76	24	74	23	72	22
274	84	29	82	28	80	27	78	26	76	24	74	23
283	86	30	84	29	82	28	80	27	78	26	76	24
291	88	31	86	30	84	29	82	28	80	27	78	26
299	90	32	88	31	86	30	84	29	82	28	80	27
308	92	33	90	32	88	31	86	30	84	29	82	28
317	94	34	92	33	90	32	88	31	86	30	84	29
326	96	36	94	34	92	33	90	32	88	31	86	30
335	98	37	96	36	94	34	92	33	90	32	88	31
345	100	38	98	37	96	36	94	34	92	33	90	32
364	104	40	102	39	100	38	98	37	96	36	94	34
374	106	41	104	40	102	39	100	38	98	37	96	36
384	108	42	106	41	104	40	102	39	100	38	98	37
395	110	43	108	42	106	41	104	40	102	39	100	38
406	112	44	110	43	108	42	106	41	104	40	102	39
416	114	46	112	44	110	43	108	42	106	41	104	40
427	116	47	114	46	112	44	110	43	108	42	106	41
439	118	48	116	47	114	46	112	44	110	43	108	42
450	120	49	118	48	116	47	114	46	112	44	110	43
462	122	50	120	49	118	48	116	47	114	46	112	44
474	124	51	122	50	120	49	118	48	116	47	114	46

SEQUENCE OF OPERATION

With power supplied to indoor and outdoor units, transformer is energized.

On a call for cooling, the thermostat makes circuits R- Y and R- G. Circuit R- Y energizes contactor, starting outdoor fan motor and compressor. Circuit R- G energizes indoor unit blower relay, starting indoor blower motor.

When thermostat is satisfied, its contacts open, de- energizing contactor and blower relay. Compressor and motors stop.

NOTE: If indoor unit is equipped with a time- delay relay circuit, the blower runs an additional length of time to increase system efficiency.

TROUBLESHOOTING

Some models are factory equipped with the Comfort Alert™ Diagnostics device in the control box (refer to Figure 14). Comfort Alert provides around-the-clock monitoring for common electrical problems, compressor defects, and broad system faults. If trouble is detected, an alert code is displayed with a flashing LED indicator. Alert codes are listed in Figure 15.

The device is factory wired and requires no modification. Low voltage lead wires are provided in the control box for connection to thermostat wires (use wire nuts).

The Comfort Alert device operates by monitoring the compressor power leads and the thermostat demand signal (Y terminal).

MAINTENANCE

Condensate Drain

During the cooling season, check monthly for free flow of drainage and clean if necessary.

Cleanliness

These tips will help keep the air conditioner looking better and working more efficiently:

1. Free flow of air is essential. Keep fences, shrubs, trash cans, and other obstructions at least 18 inches (457 mm) from all coil inlets.
2. Keep the coil free of grass clippings, leaves, weeds, and other debris.
NOTE: Coil may occasionally require cleaning with a liquid solution. The coil must be cold when cleaning. Use an alkaline based cleaner only. Cleaning a hot coil or using an acid based cleaner will remove the paint from the fins and may clog the coil.
3. Never use a weather cover over the outdoor unit unless it is a ventilated type or made of breathable fabric that will allow moisture to evaporate rapidly. A cover that holds moisture in the unit will cause more rust build-up and damage than normal exposure to weather.

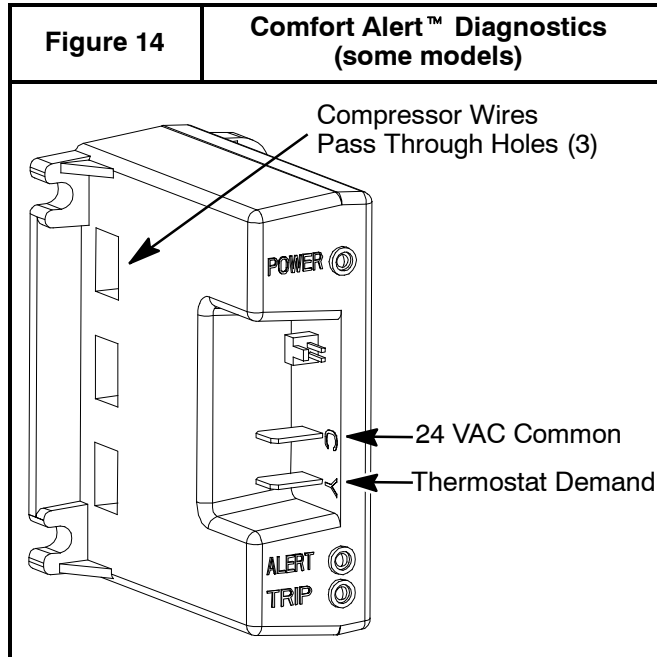

Figure 15		Comfort Alert™ Diagnostics (some models)	
Status LED	Status LED Description	Status LED Troubleshooting Information	
Green "POWER"	Module has power	Supply voltage is present at module terminals	
Red "TRIP"	Thermostat demand signal Y1 is present, but the compressor is not running	<ol style="list-style-type: none"> 1. Compressor protector is open 2. Outdoor unit power disconnect is open 3. Compressor circuit breaker or fuse(s) is open 4. Broken wire or connector is not making contact 5. Low pressure switch open if present in system 6. Compressor contactor has failed open 	
Yellow "ALERT" Flash Code 1	Long Run Time Compressor is running extremely long run cycles	<ol style="list-style-type: none"> 1. Low refrigerant charge 2. Evaporator blower is not running 3. Evaporator coil is frozen 4. Faulty metering device 5. Condenser coil is dirty 6. Liquid line restriction (filter drier blocked if present in system) 7. Thermostat is malfunctioning 	
Yellow "ALERT" Flash Code 2	System Pressure Trip Discharge or suction pressure out of limits or compressor overloaded	<ol style="list-style-type: none"> 1. High head pressure 2. Condenser coil poor air circulation (dirty, blocked, damaged) 3. Condenser fan is not running 4. Return air duct has substantial leakage 	
Yellow "ALERT" Flash Code 3	Short Cycling Compressor is running only briefly	<ol style="list-style-type: none"> 1. If high pressure switch open, go to Flash Code 2 information 2. If low pressure switch open, go to Flash Code 1 information 3. Thermostat demand signal is intermittent 4. Loose wiring at contactor coil 	
Yellow "ALERT" Flash Code 4	Locked Rotor	<ol style="list-style-type: none"> 1. Run capacitor has failed 2. Low line voltage (contact utility if voltage at disconnect is low) 3. Excessive liquid refrigerant in compressor 4. Compressor bearings are seized 	
Yellow "ALERT" Flash Code 5	Open Circuit	<ol style="list-style-type: none"> 1. Outdoor unit power disconnect is open 2. Compressor circuit breaker or fuse(s) is open 3. Compressor contactor has failed open 4. High pressure switch is open and requires manual reset 5. Open circuit in compressor supply wiring or connections 6. Unusually long compressor protector reset time due to extreme ambient temperature 7. Compressor windings are damaged 	
Yellow "ALERT" Flash Code 6	Open Start Circuit Current only in run circuit	<ol style="list-style-type: none"> 1. Run capacitor has failed 2. Open circuit in compressor start wiring or connections 3. Compressor start winding is damaged 	
Yellow "ALERT" Flash Code 7	Open Run Circuit Current only in start circuit	<ol style="list-style-type: none"> 1. Open circuit in compressor run wiring or connections 2. Compressor run winding is damaged 	
Yellow "ALERT" Flash Code 9	Low Voltage Control circuit < 17VAC	<ol style="list-style-type: none"> 1. Control circuit transformer is overloaded 2. Low line voltage (contact utility if voltage at disconnect is low) 	

- Flash Code number corresponds to a number of LED flashes, followed by a pause and then repeated.
- TRIP and ALERT LEDs flashing at same time means control circuit voltage is too low for operation.

R-410A QUICK REFERENCE GUIDE

- R-410A refrigerant operates at 50% - 70% higher pressures than R-22. Be sure that servicing equipment and replacement components are designed to operate with R-410A.
- R-410A refrigerant cylinders are rose colored.
- Recovery cylinder service pressure rating must be 400 psig, DOT 4BA400 or DOT BW400.
- R-410A systems should be charged with liquid refrigerant. Use a commercial type metering device in the manifold hose.
- Manifold sets should be 750 psig high-side and 200 psig low-side with 520 psig low-side retard.
- Use hoses with 750 psig service pressure rating.
- Leak detectors should be designed to detect HFC refrigerant.
- R-410A, as with other HFC refrigerants, is only compatible with POE oils.
- Vacuum pumps will not remove moisture from oil.
- Do not use liquid line filter-driers with rated working pressures less than 600 psig.
- Do not install a suction line filter-drier in liquid line.
- POE oils absorb moisture rapidly. Do not expose oil to atmosphere.
- POE oils may cause damage to certain plastics and roofing materials.
- Wrap all filter-driers and service valves with wet cloth when brazing.
- A liquid line filter-drier is required on every unit.
- Do not use with an R-22 TXV.
- If indoor unit is equipped with an R-22 TXV, it must be changed to an R-410A TXV.
- Never open system to atmosphere while it is under a vacuum.
- When system must be opened for service, break vacuum with dry nitrogen and replace all filter-driers.
- Do not vent R-410A into the atmosphere.
- Do not use capillary tube indoor coils.
- Observe all **WARNINGS, CAUTIONS, NOTES**, and **bold** text.