

ASHRAE 90.1 COMPLIANT PACKAGE GAS HEATING/ELECTRIC COOLING, VERTICAL SUPPLY/RETURN AIR CONFIGURATION ONLY R-410A SINGLE PACKAGE ROOFTOP 17.5 – 27.5 TONS

BUILT TO LAST, EASY TO INSTALL and SERVICE

- One-piece, standard efficiency gas heating and electric cooling with a low profile, prewired, tested, and charged at the factory
- Dedicated vertical air flow duct configuration models
- Full perimeter base rail with built-in rigging adapters and fork truck slots
- Pre-painted exterior panels and primer-coated interior panels tested to 500 hours salt spray protection
- Fully insulated cabinet
- Two-stage cooling with independent circuits and control on all models
- Redundant gas valve for two stage gas heating capacity control
- Exclusive IGC solid-state control for on-board diagnostics with LED error code designation, burner control logic and energy saving indoor fan motor delay
- High efficiency, gas heat with induced draft flue exhaust design
- Scroll compressors with internal line-break connections on all models
- All units have high and low pressure switches
- Two inch disposable fiberglass type return air filters in dedicated rack
- Refrigerant circuits contain a liquid line filter drier to trap dirt and moisture
- Round tube plate fin evaporator and condenser coil design
- Exclusive non-corrosive composite condensate pan in accordance with ASHRAE 62 Standard, sloping design; end drain
- Belt drive evaporator-fan motor and pulley combinations available to meet most applications
- Access panels with easy grip handles provide quick and easy access to the blower and blower motor, control box, and compressors
- “No-strip” screw system has superior holding power and guides screws into position while preventing the screw from stripping the unit’s metal.
- Newly designed terminal board facilitates simple safety circuit troubleshooting and simplified control box arrangement
- Standard outdoor temperature cooling operation range up to 115°F (46°C) and down to 30°F (-1°C)
- Fixed orifice metering devices on all models to precisely control refrigerant flow
- Large, laminated control wiring and power wiring drawings are affixed to unit to make troubleshooting easy
- Single point gas and electrical connections



17.5 Ton



20 and 25 Ton



WARRANTY

- 15 Year limited warranty on optional stainless steel heat exchanger
- 10 Year limited warranty on aluminized steel heat exchanger
- 5 Year compressor limited warranty
- 1 Year parts limited warranty



UNIT PERFORMANCE DATA — Two Stage Cooling								
UNIT	Dedicated Airflow	Nominal Tons	COOLING		GAS HEATING		Unit Dimensions H x W x L	Shipping Weight lb. [kg]
			Net. Cap (Btuh)	EER	Input Cap. (Btuh) Stage 2	Thermal Efficiency (%)		
RGS210 [^] AA0AAA	Vertical	17.5	208,000	10.8	220,000 - 400,000	81.0	49 3/8" x 86 5/8" x 127 7/8"	1948 [884]
RGS240 [^] AA0AAA	Vertical	20.0	242,000	9.8	220,000 - 400,000	81.0	49 3/8" x 86 5/8" x 141 1/2"	2098 [952]
RGS300 [^] AA0AAA	Vertical	25.0	280,000	9.8	220,000 - 400,000	81.0	57 3/8" x 86 5/8" x 141 1/2"	2234 [1013]
RGS336 [^] AA0AAA	Vertical	27.5	330,000	10.2	220,000 - 400,000	81.0	57 3/8" x 86 5/8" x 157 3/4"	2668 [1210]

* Indicates Unit voltage: H = 208/230-3-60, L = 460-3-60, S = 575-3-60

[^] See model nomenclature listing for gas heating options.

NOTE: BASE MODEL NUMBERS LISTED. SEE MODEL NOMENCLATURE LISTING FOR ADDITIONAL OPTIONS

TABLE OF CONTENTS

	PAGE		PAGE
MODEL NUMBER NOMENCLATURE	3	PERFORMANCE DATA	35
CAPACITY RATINGS	4	ELECTRICAL DATA	39
PHYSICAL DATA	13	TYPICAL WIRING DIAGRAMS	46
OPTIONS AND ACCESSORIES	17	CONTROLS	49
DIMENSIONS	23	GUIDE SPECIFICATIONS	52
APPLICATION DATA	33		

MODEL NUMBER NOMENCLATURE

MODEL SERIES	R	G	S	2	1	0	H	D	A	B	0	A	A	A
Position Number	1	2	3	4	5	6	7	8	9	10	11	12	13	14
R = Rooftop A = Air Conditioning (Cooling Only) G = Gas/Electric Type S = Standard ASHRAE 90.1-2010 Efficiency Efficiency 210 = 210,000 = 17.5 Tons Dedicated Vertical SA/RA (SA = Supply Air, RA = Return Air) 240 = 240,000 = 20 Tons Dedicated Vertical SA/RA 300 = 300,000 = 25 Tons Dedicated Vertical SA/RA 336 = 330,000 = 27.5 Tons Dedicated Vertical SA/RA Nominal Cooling Capacity H = 208/230-3-60 L = 460-3-60 S = 575-3-60 Voltage D = Low Heat E = Medium Heat F = High Heat S = Low Heat, Stainless Steel Heat Exchanger R = Medium Heat, Stainless Steel Heat Exchanger T = High Heat, Stainless Steel Heat Exchanger Heating Capacity A = Standard Static Option (all sizes, with 1-speed and 2-speed indoor fan motor) B = High Static High Efficiency Option (all sizes, with 2-speed indoor fan motor) C = Medium Static Option (17.5 ton, with 1-speed indoor fan motor, all sizes with 2-speed indoor fan motor) E = High Static High Efficiency Option (all sizes, with 1-speed indoor fan motor) F = Medium Static High Efficiency Option (20, 25, 27.5 ton, with 1-speed indoor fan motor) G = High Static Motor with Hot Gas Re-heat (17.5, 20, and 25, with 1-speed indoor fan motor) H = High Static Motor with Hot Gas Re-heat (17.5, 20, and 25, with 2-speed indoor fan motor) Motor Option A = None B = Economizer w/Bara-relief, OA Temp sensor E = Economizer w/Bara-relief + CO ₂ sensor, OA Temp sensor H = Economizer w/Bara-relief, Enthalpy sensor L = Economizer w/Bara-relief + CO ₂ sensor, Enthalpy sensor U = Ultra Low Leak Temp Economizer w/Bara-relief (2-speed indoor fan motor only) W = Ultra Low Leak Temp Enthalpy Economizer w/Bara-relief (2-speed indoor fan motor only) P = 2-Position damper Outdoor Air Options / Control 0A = No Options 4B = Non-fused Disconnect AA = Hinged Access Panels AT = Non-powered 115v Convenience Outlet. BR = Supply Air Smoke Detector Other Factory Installed Options ¹ A = Alum / Cu Cond and Alum / Cu Evap B = Pre coated Alum / Cu Cond and Alum / Cu Evap C = E-coated Alum / Cu Cond and Alum / Cu Evap D = E-coated Alum / E-coated Cu Cond and Alum / Cu Evap E = Cu / Cu Cond and Alum / Cu Evap F = Cu / Cu Cond and Cu / Cu Evap Coil Factory Installed Options A = Standard Motor T = 2 Speed Indoor Fan VFD Controller (For 2-stage units only) Motor Type Option														

¹ A combination of FIOP's are available.



CAPACITY RATINGS

AHRI COOLING RATINGS

RGS MODEL SIZE	COOLING STAGES	NOM. CAPACITY (TONS)	NET COOLING CAPACITY (MBH)	TOTAL POWER (kW)	EER	IEER WITH SINGLE SPEED INDOOR FAN MOTOR	IEER WITH 2-SPEED INDOOR FAN MOTOR
210	2	17.5	208.0	19.3	10.8	11.7	12.7
240	2	20.0	242.0	24.7	9.8	10.6	11.7
300	2	25.0	280.0	28.6	9.8	10.4	11.5
336	2	27.5	330.0	32.4	10.2	10.4	11.5

LEGEND

- AHRI** — Air-Conditioning, Heating and Refrigeration Institute Test Standard
ASHRAE — American Society of Heating, Refrigerating and Air-Conditioning Engineers.
EER — Energy Efficiency Ratio
IEER — Integrated Energy Efficiency Ratio
IECC — International Energy Conservation Code

NOTES:

- Rated and certified under AHRI Standard 340/360, as appropriate.
- Ratings are based on:
Cooling Standard: 80°F (27°C) db, 67°F (19°C) wb indoor air temp and 95°F (35°C) db outdoor air temp.
IEER Standard: A measure that expresses cooling part load EER efficiency for commercial unitary air conditioning and heat pump equipment on the basis of weighted operation at various load capacities.
- The RGS rooftops meet ASHRAE 90.1-2016, DOE-2018 and IECC¹-2015 minimum efficiency requirements when equipped with the 2-Speed Indoor Fan Motor option.
- RGS units comply with US Energy Policy Act (2005). To evaluate code compliance requirements, refer to state and local codes or visit the following website: <http://bcap-energy.org> to determine if compliance with this standard pertains to your state, territory, or municipality.



¹ IECC is a registered trademark of International Code Council, Inc.

HEATING RATING TABLE - NATURAL GAS AND PROPANE

RGS MODEL SIZE	HEAT SIZE	AL/SS HEAT EXCHANGER		TEMP RISE (DEG F)	THERMAL EFFICIENCY (%)
		INPUT / OUTPUT STAGE 2 (Mbh)	INPUT / OUTPUT STAGE 1 (Mbh)		
210	LOW	220 / 178	176 / 142	15 - 55	81%
	MED	310 / 251	248 / 200	25 - 60	81%
	HIGH	400 / 324	320 / 260	30 - 65	81%
240	LOW	220 / 178	176 / 142	15 - 55	81%
	MED	310 / 251	248 / 200	20 - 60	81%
	HIGH	400 / 324	320 / 260	30 - 65	81%
300	LOW	220 / 178	176 / 142	10 - 55	81%
	MED	310 / 251	248 / 200	15 - 60	81%
	HIGH	400 / 324	320 / 260	20 - 65	81%
336	LOW	220 / 178	176 / 142	10 - 55	81%
	MED	310 / 251	248 / 200	15 - 60	81%
	HIGH	400 / 324	320 / 260	20 - 65	81%

NOTES:

- Heat ratings are for natural gas heat exchangers operated at or below 2000 ft (610 m). For information on Propane or altitudes above 2000 ft (610 m), see the Application Data section of this book. Accessory Propane/High Altitude kits are also available.
- The input rating for altitudes above 2000 ft (610 m) must be de-rated by 4% for each 1000 ft (305 m) above sea level.

SOUND PERFORMANCE

RGS MODEL SIZE	COOLING STAGES	OUTDOOR SOUND (dB) AT 60 Hz									
		A-WEIGHTED	AHRI 370 RATING	63	125	250	500	1000	2000	4000	8000
210	2	84.1	84	92.2	83.9	80.4	81.8	78.7	76.5	72.2	65.4
240	2	86.5	87	95.6	87.5	84.2	84.2	81.7	77.9	73.2	66.3
300	2	85.9	86	97.1	88.3	84.4	83.3	80.7	77.4	73.4	67.3
336	2	85.9	86	97.1	88.3	84.4	83.3	80.7	77.4	73.4	67.3

LEGEND
dB — Decibel

NOTES:

1. Outdoor sound data is measured in accordance with AHRI standard 370.
2. Measurements are expressed in terms of sound power. Do not compare these values to sound pressure values because sound pres-

sure depends on specific environmental factors which normally do not match individual applications. Sound power values are independent of the environment and therefore more accurate.

3. A-weighted sound ratings filter out very high and very low frequencies, to better approximate the response of "average" human ear. A-weighted measurements for units are taken in accordance with AHRI standard 370.

MINIMUM - MAXIMUM AIRFLOW RATINGS - NATURAL GAS AND PROPANE

RGS MODEL SIZE	HEAT LEVEL	COOLING				AL HX HEATING		SS HX HEATING	
		MINIMUM SINGLE SPEED FAN MOTOR	MINIMUM 2-SPEED FAN MOTOR (AT HIGH SPEED)	MINIMUM 2-SPEED FAN MOTOR (AT LOW SPEED)	MAXIMUM	MINIMUM	MAXIMUM	MINIMUM	MAXIMUM
210	LOW	5250	5915	3943	9000	3000	11000	3000	11000
	MED					3880	9300	3880	9300
	HIGH					4620	10000	4620	10000
240	LOW	6000	7500	5000	10000	3000	11000	3000	11000
	MED					3880	11630	3880	11630
	HIGH					4620	10000	4620	10000
300	LOW	7500	8450	5633	12500	3000	16500	3000	16500
	MED					3880	15500	3880	15500
	HIGH					4620	15000	4620	15000
336	LOW	8250	9450	6300	13750	3000	16500	3000	16500
	MED					3880	15500	3880	15500
	HIGH					4620	15000	4620	15000

LEGEND
AL HX — Aluminum Gas Heat Exchanger
SS HX — Stainless Steel Gas Heat Exchanger

CAPACITY RATINGS (CONT)

COOLING CAPACITIES, 2-STAGE COOLING, 17.5 TONS

RGS210			AMBIENT TEMPERATURE (F)													
			85			95			105			115				
			EAT (db)			EAT (db)			EAT (db)			EAT (db)				
			75	80	85	75	80	85	75	80	85	75	80	85		
5250 Cfm	EAT (wb)	58	THC	180.4	185.6	196.3	167.7	176.1	186.9	154.7	165.3	176.6	142.2	153.6	164.9	
			SHC	166.5	185.6	196.3	160.6	176.1	186.9	152.7	165.3	176.6	142.2	153.6	164.9	
		62	THC	196.2	195.5	196.9	183.6	182.9	187.2	169.3	168.7	176.9	153.4	154.1	165.2	
			SHC	146.8	172.1	194.7	141.4	166.6	187.2	135.4	160.5	176.9	128.6	152.5	165.2	
		67	THC	216.7	215.9	215.2	204.9	204.1	203.1	190.6	189.7	189.0	174.8	174.0	173.3	
			SHC	120.0	146.1	171.8	115.4	141.5	167.1	109.8	136.1	161.7	103.8	130.2	155.6	
	72	THC	237.4	236.8	236.0	226.0	225.1	224.2	212.8	211.9	211.0	197.3	196.4	195.5		
		SHC	92.0	118.3	144.3	87.8	114.3	140.4	83.0	109.6	135.8	77.6	104.2	130.6		
	76	THC	—	252.9	253.0	—	242.5	241.6	—	229.1	228.2	—	214.1	213.1		
		SHC	—	95.1	121.4	—	91.7	118.0	—	87.3	113.8	—	82.5	107.1		
	6125 Cfm	EAT (wb)	58	THC	188.8	198.5	209.3	176.5	188.2	200.2	164.5	176.7	189.0	151.9	164.2	176.7
				SHC	180.4	198.5	209.3	174.4	188.2	200.2	164.5	176.7	189.0	151.9	164.2	176.7
62			THC	205.2	204.6	209.6	191.8	191.5	200.4	176.6	177.6	189.2	159.9	164.2	176.9	
			SHC	159.9	188.7	209.6	154.2	183.0	200.4	147.9	174.8	189.2	141.0	164.2	176.9	
67			THC	225.5	224.5	223.5	213.5	212.5	211.7	199.1	198.3	197.4	182.3	181.4	180.9	
			SHC	128.3	158.4	187.8	123.8	154.1	183.5	118.4	148.9	178.1	112.2	142.7	171.6	
72		THC	245.6	245.3	244.6	234.7	233.6	232.6	220.9	219.9	218.8	205.5	204.4	203.4		
		SHC	95.4	125.9	155.7	91.7	122.2	152.4	86.9	117.7	148.1	81.7	112.5	143.1		
76		THC	—	262.0	261.2	—	250.7	250.1	—	237.3	236.2	—	221.6	220.6		
		SHC	—	99.5	129.4	—	95.9	126.2	—	91.8	122.4	—	87.0	117.8		
7000 Cfm		EAT (wb)	58	THC	197.4	209.8	221.3	186.1	199.1	211.7	173.8	186.9	200.1	160.3	173.5	186.9
				SHC	196.8	209.8	221.3	186.1	199.1	211.7	173.8	186.9	200.1	160.3	173.5	186.9
	62		THC	212.7	212.4	221.5	198.4	199.8	212.0	182.3	186.9	200.3	164.7	173.8	187.1	
			SHC	173.4	205.1	221.5	167.4	197.4	212.0	160.8	186.8	200.3	153.4	173.8	187.1	
	67		THC	233.7	232.5	231.4	220.8	219.8	218.9	205.6	204.5	204.1	187.8	186.8	188.0	
			SHC	138.0	172.0	205.0	133.4	167.6	200.4	127.8	162.0	194.4	121.3	155.6	185.6	
	72	THC	254.3	253.3	252.8	242.7	241.5	240.3	228.0	226.8	225.7	211.8	210.6	209.3		
		SHC	101.3	135.4	169.2	97.3	131.8	165.9	92.3	127.2	161.5	86.9	121.8	156.3		
	76	THC	—	270.7	269.9	—	259.0	258.1	—	245.0	243.6	—	228.5	227.1		
		SHC	—	106.1	140.0	—	102.4	136.5	—	98.2	132.7	—	93.2	127.9		
	7875 Cfm	EAT (wb)	58	THC	205.0	217.2	229.1	193.4	206.9	219.3	180.6	194.3	207.9	166.6	180.5	194.5
				SHC	205.0	217.2	229.1	193.4	206.9	219.3	180.6	194.3	207.9	166.6	180.5	194.5
62			THC	216.7	217.4	229.4	202.5	207.1	219.6	185.9	194.5	208.4	168.4	180.7	194.7	
			SHC	183.9	217.4	229.4	178.2	207.1	219.6	171.5	194.5	208.4	141.2	180.7	194.7	
67			THC	237.8	236.7	235.7	224.7	223.5	223.0	209.5	208.3	209.2	191.5	190.3	195.0	
			SHC	144.6	182.4	219.3	140.3	178.2	213.7	134.9	172.7	205.9	113.6	166.2	195.0	
72		THC	258.6	257.5	256.5	246.8	245.7	244.3	231.8	230.5	229.2	215.3	213.9	212.5		
		SHC	103.9	141.8	179.2	100.0	138.3	176.1	95.1	133.9	172.1	89.7	128.6	142.0		
76		THC	—	275.4	274.2	—	262.7	261.8	—	248.7	247.6	—	231.9	230.5		
		SHC	—	109.5	147.0	—	105.7	143.6	—	101.5	139.9	—	96.6	135.4		
8750 Cfm		EAT (wb)	58	THC	211.3	223.6	235.9	199.7	213.4	225.7	186.4	200.7	214.3	172.1	186.5	200.9
				SHC	211.3	223.6	235.9	199.7	213.4	225.7	186.4	200.7	214.3	172.1	186.5	200.9
	62		THC	220.0	223.7	236.3	206.0	213.6	226.1	189.3	200.9	214.5	172.2	186.7	201.2	
			SHC	194.0	223.7	236.3	188.5	213.6	226.1	181.3	200.9	214.5	172.2	186.7	201.2	
	67		THC	241.1	240.1	239.7	227.9	226.6	226.9	212.7	211.4	214.9	194.4	193.0	201.4	
			SHC	151.0	192.1	230.2	146.9	188.3	225.2	141.6	182.9	214.8	135.3	176.3	201.4	
	72	THC	262.2	261.0	259.7	250.0	248.8	247.7	235.0	233.5	232.1	218.1	216.6	215.2		
		SHC	106.5	148.1	189.0	102.5	144.5	186.0	97.8	140.4	182.1	92.4	135.3	177.1		
	76	THC	—	278.9	277.4	—	266.0	264.8	—	251.5	250.6	—	234.7	233.0		
		SHC	—	112.7	153.7	—	108.9	150.4	—	104.7	146.7	—	100.0	142.4		

LEGEND

- Do not operate
- Cfm — Cubic feet per minute (supply air)
- EAT (db) — Entering Air Temperature (dry bulb)
- EAT (wb) — Entering Air Temperature (wet bulb)
- SHC — Sensible Heat Capacity (1000 Btuh) Gross
- TC — Total Capacity (1000 Btuh) Gross

NOTE: See Minimum-Maximum Airflow - Natural Gas and Propane Ratings on page 5. Do not operate outside these limits.

COOLING CAPACITIES, 2-STAGE COOLING, 17.5 TONS (cont)

TEMP (F) AIR ENTERING CONDENSER (Edb)		17.5 TONS - UNIT WITH HOT GAS RE-HEAT IN SUBCOOLING MODE								
		Air Entering Evaporator - CFM								
		5,250			7,000			8,750		
		Air Entering Evaporator - Ewb (F)								
		72	67	62	72	67	62	72	67	62
75	TC	218.70	199.60	180.50	241.40	219.40	197.40	261.70	237.20	212.70
	SHC	99.90	123.90	147.80	112.70	136.90	161.10	122.90	147.30	171.70
	kW	11.81	11.56	11.20	13.81	13.48	13.16	14.82	14.58	14.16
85	TC	206.60	187.90	169.10	224.90	203.40	181.90	241.30	217.30	193.40
	SHC	78.90	108.40	137.90	92.20	122.10	152.00	103.00	133.10	163.30
	kW	13.18	12.53	12.53	15.18	14.85	14.52	16.21	15.85	15.54
95	TC	194.70	176.20	157.80	208.40	187.40	166.40	220.80	197.40	174.10
	SHC	57.80	92.90	128.00	71.70	107.30	142.90	83.00	118.90	154.90
	kW	14.56	14.21	13.88	16.56	16.21	15.87	17.56	17.22	16.01
105	TC	182.70	164.50	146.40	191.90	171.40	150.80	200.30	177.60	154.80
	SHC	36.80	77.40	118.10	51.30	92.50	133.80	63.00	104.70	146.40
	kW	15.93	15.58	15.20	17.94	17.58	17.22	18.95	18.59	18.24
115	TC	170.60	152.80	135.00	175.40	155.40	135.30	179.80	157.70	135.50
	SHC	15.70	62.00	108.20	30.80	77.80	124.70	43.00	90.50	128.00
	kW	17.31	16.95	16.58	19.32	18.95	18.58	20.32	19.96	19.59

TEMP (F) AIR ENTERING CONDENSER (Edb)		17.5 TONS - UNIT WITH HOT GAS RE-HEAT IN HOT GAS REHEAT MODE								
		Air Entering Evaporator (F)								
		75 Dry Bulb			75 Dry Bulb			75 Dry Bulb		
		62.5 Wet Bulb			64 Wet Bulb			65.3 Wet Bulb		
		(50% Relative)			(56% Relative)			(60% Relative)		
		Air Entering Evaporator - CFM								
		5,250	7,000	8,750	5,250	7,000	8,750	5,250	7,000	8,750
80	TC	82.20	90.50	92.40	86.70	96.40	97.80	91.60	99.80	101.20
	SHC	18.20	29.40	41.60	8.60	17.20	27.50	0.50	9.30	13.20
	kW	12.64	12.73	12.88	12.78	13.06	13.15	12.96	13.07	13.22
75	TC	84.40	92.70	94.40	88.80	98.60	99.70	93.70	102.00	103.40
	SHC	19.70	31.30	43.50	10.10	18.80	29.20	12.10	10.80	15.30
	kW	12.60	12.71	12.85	12.75	13.02	13.12	12.93	13.03	13.19
70	TC	86.70	94.90	96.60	91.00	100.70	102.00	95.90	104.10	105.40
	SHC	21.30	32.80	44.80	11.60	20.40	30.70	3.80	12.30	16.50
	kW	12.56	12.66	12.82	12.70	12.99	13.08	12.89	13.00	13.14
60	TC	90.90	99.10	100.80	95.20	105.00	106.30	100.20	108.30	109.70
	SHC	24.80	36.00	48.20	14.90	23.90	35.90	7.20	15.60	19.60
	kW	12.49	12.60	12.75	12.64	12.92	13.02	12.83	12.93	13.09
50	TC	95.00	103.40	105.10	99.50	109.40	110.50	104.40	112.50	113.90
	SHC	28.10	39.30	51.30	18.20	27.20	37.40	10.30	18.90	23.20
	kW	12.43	12.53	12.67	12.57	12.86	12.95	12.76	12.87	13.02
40	TC	99.20	107.70	109.30	103.70	113.70	114.70	108.60	116.70	118.10
	SHC	31.40	42.50	54.40	21.30	30.40	40.50	13.40	22.00	26.50
	kW	12.35	12.45	12.61	12.50	12.79	12.87	12.68	12.80	12.94

LEGEND

- Edb** — Entering Dry-Bulb
- Ewb** — Entering Wet-Bulb
- kW** — Compressor Motor Power Input
- ldb** — Leaving Dry-Bulb
- lwb** — Leaving Wet-Bulb
- SHC** — Sensible Heat Capacity (1000 Btuh) Gross
- TC** — Total Capacity (1000 Btuh) Gross

NOTES:

1. Direct interpolation is permissible. Do not extrapolate.
2. The following formulas may be used:

$$t_{ldb} = t_{edb} - \frac{\text{sensible capacity (Btuh)}}{1.10 \times \text{cfm}}$$

$$t_{lwb} = \text{Wet-bulb temperature corresponding to enthalpy of air leaving evaporator coil } (h_{lwb})$$

$$h_{lwb} = h_{ewb} - \frac{\text{total capacity (Btuh)}}{4.5 \times \text{cfm}}$$

Where: h_{ewb} = Enthalpy of air entering evaporator coil

CAPACITY RATINGS (CONT)

COOLING CAPACITIES, 2-STAGE COOLING, 20 TONS

RGS240				AMBIENT TEMPERATURE (F)												
				85			95			105			115			
				EAT (db)			EAT (db)			EAT (db)			EAT (db)			
				75	80	85	75	80	85	75	80	85	75	80	85	
6000 Cfm	EAT (wb)	58	THC	213.1	217.2	228.7	199.9	207.5	219.4	184.8	195.8	208.4	169.6	182.6	195.6	
			SHC	194.3	217.2	228.7	188.0	207.5	219.4	179.0	195.8	208.4	169.6	182.6	195.6	
		62	THC	230.0	229.4	230.4	217.5	217.0	219.7	202.5	201.9	208.8	184.9	184.9	195.9	
			SHC	170.0	199.9	225.9	164.6	194.5	219.7	158.3	187.8	208.8	150.9	178.7	195.9	
		67	THC	251.5	251.1	250.6	239.4	238.7	238.1	225.4	224.7	224.0	208.8	208.2	207.4	
			SHC	137.5	168.1	198.4	132.9	163.4	193.7	127.5	158.1	188.2	121.1	151.9	181.9	
	72	THC	274.0	273.8	273.5	262.3	261.7	261.0	248.2	247.4	246.6	232.2	231.3	230.5		
		SHC	104.3	135.1	165.6	100.1	130.9	161.4	95.1	125.9	156.6	89.6	120.5	151.3		
	76	THC	—	292.9	292.2	—	280.5	279.9	—	266.3	265.6	—	250.6	249.8		
		SHC	—	108.1	138.6	—	104.1	134.9	—	99.6	130.4	—	94.6	125.5		
	7000 Cfm	EAT (wb)	58	THC	220.8	229.7	241.7	208.4	219.7	232.2	194.3	208.1	221.0	180.1	194.2	207.9
				SHC	211.0	229.7	241.7	203.1	219.7	232.2	194.3	208.1	221.0	180.1	194.2	207.9
62			THC	237.8	237.3	241.9	225.1	224.6	232.3	209.6	210.2	221.3	191.3	196.0	208.2	
			SHC	183.3	217.8	241.9	178.2	212.1	232.3	171.8	203.8	221.3	164.3	196.0	208.2	
67			THC	260.0	259.2	258.5	247.2	246.4	245.7	232.7	231.9	231.7	215.8	215.0	214.3	
			SHC	146.0	181.0	215.7	141.3	176.5	211.2	136.0	171.3	206.3	129.8	165.3	199.4	
72		THC	283.3	282.5	281.8	270.6	269.8	268.9	255.9	255.0	254.1	240.0	238.9	238.0		
		SHC	107.9	143.2	178.1	103.6	139.0	174.1	98.6	134.2	169.5	93.2	129.0	164.4		
76		THC	—	302.3	301.6	—	289.1	288.4	—	274.4	273.6	—	257.9	256.8		
		SHC	—	112.3	147.5	—	108.3	143.7	—	103.9	139.4	—	98.9	134.5		
8000 Cfm		EAT (wb)	58	THC	232.1	243.6	256.1	219.8	233.4	246.0	206.9	221.3	234.5	192.1	206.8	221.2
				SHC	227.5	243.6	256.1	219.8	233.4	246.0	206.9	221.3	234.5	192.1	206.8	221.2
	62		THC	247.8	247.1	256.4	234.7	235.5	246.2	218.7	221.1	234.7	199.5	207.0	221.4	
			SHC	199.5	236.7	256.4	194.3	229.1	246.2	187.8	221.1	234.7	179.9	207.0	221.4	
	67		THC	270.2	269.3	268.3	257.0	256.1	255.2	242.1	241.0	240.3	224.5	223.5	223.1	
			SHC	157.6	197.1	235.6	152.7	192.6	231.0	147.3	187.2	225.3	141.0	181.0	215.6	
	72	THC	294.1	293.1	292.2	280.7	279.7	278.4	265.9	264.7	263.8	248.9	247.6	246.6		
		SHC	114.8	154.6	193.9	110.3	150.4	190.0	105.4	145.6	185.5	99.7	140.1	180.2		
	76	THC	—	313.1	312.3	—	299.3	298.2	—	283.8	282.8	—	266.7	265.4		
		SHC	—	120.2	159.6	—	116.0	155.9	—	111.4	151.5	—	106.2	146.6		
	9000 Cfm	EAT (wb)	58	THC	238.5	252.5	266.0	226.8	241.6	255.6	213.1	228.2	243.0	197.5	213.0	229.2
				SHC	238.5	252.5	266.0	226.8	241.6	255.6	213.1	228.2	243.0	197.5	213.0	229.2
62			THC	253.0	254.1	266.3	238.6	241.6	255.7	221.0	228.4	243.3	201.1	213.2	229.4	
			SHC	211.9	249.1	266.3	206.2	241.6	255.7	199.2	228.4	243.3	164.2	213.2	229.4	
67			THC	276.9	275.8	274.8	263.0	261.8	261.0	246.5	245.2	246.6	228.2	225.9	229.6	
			SHC	165.6	209.9	252.2	160.7	205.1	247.0	154.9	199.3	238.5	132.3	192.7	229.6	
72		THC	302.2	301.0	299.7	287.9	286.6	285.4	272.3	270.9	269.6	254.3	252.9	251.6		
		SHC	118.2	162.8	206.8	113.5	158.4	202.9	108.5	153.4	198.0	102.7	147.8	165.1		
76		THC	—	322.0	320.8	—	307.7	306.1	—	291.4	289.9	—	275.1	272.5		
		SHC	—	124.5	168.7	—	120.4	164.9	—	115.6	160.5	—	110.9	155.3		
10,000 Cfm		EAT (wb)	58	THC	245.7	259.8	273.9	233.8	248.7	263.2	219.8	235.3	250.5	203.7	219.8	236.5
				SHC	245.7	259.8	273.9	233.8	248.7	263.2	219.8	235.3	250.5	203.7	219.8	236.5
	62		THC	256.8	260.7	274.2	242.2	249.0	263.3	224.6	235.6	250.6	205.6	220.0	236.8	
			SHC	223.8	258.4	274.2	218.1	249.0	263.3	211.0	235.6	250.6	199.3	220.0	236.8	
	67		THC	280.8	279.6	266.3	266.6	265.4	265.8	249.9	248.6	251.0	231.4	229.8	237.3	
			SHC	173.2	221.8	266.3	168.3	217.0	258.7	162.6	211.4	250.7	156.4	204.7	237.3	
	72	THC	306.4	305.0	274.8	292.1	290.6	289.3	276.0	274.3	273.0	257.5	256.0	254.6		
		SHC	121.2	170.1	252.2	116.6	165.9	214.8	111.5	161.0	210.0	105.7	155.4	204.5		
	76	THC	—	326.2	299.7	—	311.4	310.0	—	295.2	293.2	—	277.0	275.3		
		SHC	—	128.2	206.8	—	124.0	172.9	—	119.5	168.9	—	114.3	163.8		

LEGEND

- Do not operate
- Cfm — Cubic feet per minute (supply air)
- EAT (db) — Entering Air Temperature (dry bulb)
- EAT (wb) — Entering Air Temperature (wet bulb)
- SHC — Sensible Heat Capacity (1000 Btuh) Gross
- TC — Total Capacity (1000 Btuh) Gross

NOTE: See Minimum-Maximum Airflow - Natural Gas and Propane Ratings on page 5. Do not operate outside these limits.

COOLING CAPACITIES, 2-STAGE COOLING, 20 TONS (cont)

TEMP (F) AIR ENTERING CONDENSER (Edb)		20 TONS - UNIT WITH HOT GAS RE-HEAT IN SUBCOOLING MODE								
		Air Entering Evaporator - CFM								
		6,000			8,000			10,000		
		Air Entering Evaporator - Ewb (F)								
		72	67	62	72	67	62	72	67	62
75	TC	263.00	240.40	217.70	301.00	274.00	246.90	336.90	305.60	274.40
	SHC	125.30	151.60	178.00	144.40	171.10	198.00	160.00	186.90	213.90
	kW	15.63	15.20	14.65	15.91	15.62	14.98	16.26	15.92	15.21
85	TC	248.20	226.10	204.00	279.20	252.90	226.60	308.40	278.20	248.00
	SHC	98.90	131.70	164.50	118.60	152.00	185.30	134.60	168.40	202.20
	kW	17.50	17.04	16.50	17.74	17.51	16.75	18.08	17.73	17.03
95	TC	233.40	211.80	190.20	257.30	231.80	206.40	279.80	250.70	221.50
	SHC	72.40	111.80	151.10	92.70	132.80	172.90	109.30	149.90	190.60
	kW	19.36	18.96	18.35	19.61	19.37	18.67	20.02	19.62	18.97
105	TC	218.60	197.50	176.50	235.40	210.70	186.10	251.30	223.20	195.10
	SHC	46.00	91.80	137.70	66.90	113.60	160.40	83.90	131.40	178.90
	kW	21.23	20.76	20.18	21.53	21.22	20.52	21.91	21.52	20.77
115	TC	203.70	183.30	162.80	213.50	189.70	165.80	222.70	195.70	168.70
	SHC	19.50	71.90	124.20	41.00	94.40	147.90	58.50	112.90	157.20
	kW	23.02	22.58	22.02	23.42	23.02	22.38	23.73	23.41	22.57

TEMP (F) AIR ENTERING CONDENSER (Edb)		20 TONS - UNIT WITH HOT GAS RE-HEAT IN HOT GAS REHEAT MODE								
		Air Entering Evaporator (F)								
		75 Dry Bulb			75 Dry Bulb			75 Dry Bulb		
		62.5 Wet Bulb			64 Wet Bulb			65.3 Wet Bulb		
		(50% Relative)			(56% Relative)			(60% Relative)		
		Air Entering Evaporator - CFM								
		6,000	8,000	10,000	6,000	8,000	10,000	6,000	8,000	10,000
80	TC	91.50	100.80	109.50	95.80	105.70	112.40	102.30	110.80	118.60
	SHC	12.30	31.20	44.50	0.90	15.10	25.70	-6.50	3.60	13.90
	kW	14.82	15.01	15.24	15.35	15.45	15.52	15.56	15.65	15.73
75	TC	94.00	103.40	112.00	98.70	108.10	115.10	104.70	113.10	121.10
	SHC	13.60	32.40	45.70	2.00	16.00	26.60	-5.60	4.70	15.10
	kW	14.90	15.07	15.33	15.43	15.56	15.64	15.69	15.77	15.85
70	TC	96.50	106.00	114.30	100.90	110.60	117.20	107.20	115.80	123.50
	SHC	14.50	33.20	45.70	3.30	17.30	28.00	-4.00	5.90	16.20
	kW	14.97	15.17	15.41	15.50	15.66	15.75	15.80	15.87	15.94
60	TC	101.80	111.30	119.30	106.20	115.60	122.20	112.60	119.40	128.00
	SHC	16.70	35.50	48.60	5.60	19.40	30.30	-1.80	8.20	18.50
	kW	15.14	15.32	15.58	15.66	15.88	15.97	16.05	16.10	16.19
50	TC	107.20	116.40	124.30	111.50	120.70	127.30	117.70	125.20	132.90
	SHC	18.60	37.60	50.70	8.00	22.00	32.70	0.50	10.50	21.00
	kW	15.27	15.46	15.76	15.81	16.10	16.23	16.27	16.34	16.41
40	TC	112.20	121.80	129.20	116.60	125.70	132.00	123.20	130.00	138.00
	SHC	21.80	39.50	52.90	10.20	24.40	35.20	2.90	13.00	23.40
	kW	15.42	15.63	15.93	15.96	16.32	16.44	16.52	16.57	16.65

LEGEND

- Edb** — Entering Dry-Bulb
- Ewb** — Entering Wet-Bulb
- kW** — Compressor Motor Power Input
- ldb** — Leaving Dry-Bulb
- lwb** — Leaving Wet-Bulb
- SHC** — Sensible Heat Capacity (1000 Btuh) Gross
- TC** — Total Capacity (1000 Btuh) Gross

NOTES:

1. Direct interpolation is permissible. Do not extrapolate.
2. The following formulas may be used:

$$t_{ldb} = t_{edb} - \frac{\text{sensible capacity (Btuh)}}{1.10 \times \text{cfm}}$$

$$t_{lwb} = \text{Wet-bulb temperature corresponding to enthalpy of air leaving evaporator coil } (h_{lwb})$$

$$h_{lwb} = h_{ewb} - \frac{\text{total capacity (Btuh)}}{4.5 \times \text{cfm}}$$

Where: h_{ewb} = Enthalpy of air entering evaporator coil

CAPACITY RATINGS (CONT)

COOLING CAPACITIES, 2-STAGE COOLING, 25 TONS

RGS300			AMBIENT TEMPERATURE (F)														
			85			95			105			115					
			EAT (db)			EAT (db)			EAT (db)			EAT (db)					
			75	80	85	75	80	85	75	80	85	75	80	85			
7,500 Cfm	EAT (wb)	58	THC	257.3	266.5	279.6	247.5	255.4	269.0	231.5	243.3	257.2	214.3	229.2	243.7		
		58	SHC	247.5	266.5	279.6	231.1	255.4	269.0	223.5	243.3	257.2	213.2	229.2	243.7		
		62	THC	281.4	280.5	280.6	267.5	267.0	269.3	251.3	251.0	257.6	232.7	232.5	244.1		
		62	SHC	208.2	244.0	278.0	202.3	238.4	269.3	195.8	231.5	257.6	188.1	223.4	244.1		
		67	THC	307.4	306.4	305.7	293.0	292.2	291.4	276.9	276.2	275.4	259.7	259.2	258.8		
		67	SHC	168.7	205.7	242.3	163.2	200.3	236.9	157.1	194.4	230.7	150.6	188.4	224.8		
	76	72	THC	333.9	333.2	332.5	320.1	319.3	318.6	304.5	303.7	302.7	287.2	285.3	284.5		
		72	SHC	128.1	165.4	202.3	123.1	160.6	197.8	117.6	155.1	192.5	111.5	149.0	186.6		
		76	THC	—	356.0	355.2	—	342.0	341.2	—	326.0	325.2	—	308.0	307.4		
		76	SHC	—	132.7	169.9	—	128.1	165.6	—	123.0	160.7	—	117.3	154.5		
		8,750 Cfm	EAT (wb)	58	THC	269.8	280.2	294.4	255.3	268.9	283.2	241.1	256.1	270.7	225.5	241.3	257.3
				58	SHC	257.9	280.2	294.4	250.4	268.9	283.2	241.1	256.1	270.7	225.5	241.3	257.3
62	THC			289.9	289.3	294.6	275.3	274.9	283.6	258.7	258.2	271.0	238.8	241.6	257.6		
62	SHC			224.2	265.0	294.6	218.6	258.6	283.6	212.0	251.7	271.0	203.9	241.6	257.6		
67	THC			316.2	315.7	314.5	301.7	300.8	299.8	285.1	284.2	283.4	266.7	266.0	265.2		
67	SHC			179.0	221.6	263.1	173.5	216.4	257.9	167.5	210.5	251.9	161.0	204.5	245.1		
76	72		THC	343.7	342.7	341.6	315.3	327.9	327.0	313.1	311.4	310.4	294.3	293.2	292.2		
	72		SHC	132.4	175.4	217.7	127.6	170.7	213.3	122.0	165.3	208.3	115.6	159.2	202.5		
	76		THC	—	366.0	364.9	—	351.2	350.1	—	334.2	333.2	—	315.4	314.3		
	76		SHC	—	138.0	180.7	—	133.4	176.5	—	128.2	171.6	—	122.5	166.1		
	10,000 Cfm		EAT (wb)	58	THC	277.1	291.8	306.8	264.9	280.2	295.3	251.2	267.0	282.3	235.1	252.2	268.1
				58	SHC	275.3	291.8	306.8	264.9	280.2	295.3	251.2	267.0	282.3	235.1	252.2	268.1
62		THC		296.8	296.0	307.2	281.8	281.8	295.6	264.7	267.1	282.6	244.9	252.4	268.4		
62		SHC		239.8	283.9	307.2	234.0	276.8	295.6	227.5	267.1	282.6	219.4	252.4	268.4		
67		THC		323.5	322.6	321.4	308.5	307.4	306.5	291.3	290.2	289.3	272.5	271.5	270.8		
67		SHC		188.8	236.9	282.9	183.5	231.9	277.4	177.5	226.1	271.2	171.2	219.7	264.3		
76		72	THC	351.8	350.5	349.2	336.6	335.4	334.1	319.7	318.3	317.1	300.2	298.9	297.8		
		72	SHC	136.6	185.1	232.8	131.6	180.4	228.6	126.0	175.1	223.7	119.7	169.1	217.9		
		76	THC	—	374.2	372.8	—	358.6	357.3	—	340.9	339.7	—	321.3	320.1		
		76	SHC	—	143.1	191.2	—	138.5	187.1	—	133.3	182.3	—	127.6	176.8		
		11,250 Cfm	EAT (wb)	58	THC	285.8	301.5	317.0	273.8	289.0	305.1	259.8	276.1	291.7	244.0	260.9	277.4
				58	SHC	285.8	301.5	317.0	273.8	289.0	305.1	259.8	276.1	291.7	244.0	260.9	277.4
62	THC			302.2	302.3	317.4	286.3	289.5	305.4	269.6	276.4	208.4	249.3	261.1	277.6		
62	SHC			254.3	300.2	317.4	245.8	289.5	305.4	242.1	276.4	208.4	201.5	261.1	277.6		
67	THC			328.7	327.7	326.7	313.5	312.2	311.1	296.0	294.8	294.3	277.5	275.7	277.9		
67	SHC			197.9	251.1	301.0	192.8	246.4	295.4	187.0	240.4	288.0	160.9	234.6	277.9		
76	72		THC	357.4	355.9	354.4	341.8	340.3	339.0	324.4	322.8	321.6	304.8	303.2	302.0		
	72		SHC	140.2	193.9	246.7	135.2	189.4	242.8	129.7	184.3	238.2	123.5	178.4	198.1		
	76		THC	—	379.7	378.2	—	363.9	362.3	—	345.7	344.2	—	327.5	324.0		
	76		SHC	—	147.6	200.8	—	143.1	196.9	—	138.0	192.3	—	132.9	187.1		
	12,500 Cfm		EAT (wb)	58	THC	293.7	309.8	325.6	280.3	297.3	313.5	267.0	283.5	299.8	250.8	268.3	284.8
				58	SHC	293.7	309.8	325.6	280.3	297.3	313.5	267.0	283.5	299.8	250.8	268.3	284.8
62		THC		310.5	310.2	326.1	290.7	297.6	313.9	273.7	283.7	300.1	253.1	268.5	285.0		
62		SHC		264.9	310.1	326.1	262.1	297.6	313.9	255.7	283.7	300.1	246.9	268.5	285.0		
67		THC		333.1	331.7	330.9	317.5	316.2	315.9	299.8	298.7	300.3	280.7	279.6	285.5		
67		SHC		206.6	264.7	317.6	201.9	260.2	311.0	196.2	254.9	300.3	190.0	248.1	285.5		
76		72	THC	362.1	360.3	358.7	346.0	344.3	343.0	328.2	326.6	325.1	308.4	306.6	305.3		
		72	SHC	143.6	202.4	260.2	138.7	198.1	256.5	133.2	193.2	252.1	127.1	187.5	246.5		
		76	THC	—	384.3	382.5	—	368.1	366.3	—	349.5	347.8	—	331.0	328.7		
		76	SHC	—	151.9	210.1	—	147.5	206.4	—	142.5	201.9	—	137.4	195.2		

LEGEND

- I — Do not operate
- Cfm — Cubic feet per minute (supply air)
- EAT (db) — Entering Air Temperature (dry bulb)
- EAT (wb) — Entering Air Temperature (wet bulb)
- SHC — Sensible Heat Capacity (1000 Btuh) Gross
- TC — Total Capacity (1000 Btuh) Gross

NOTE: See Minimum-Maximum Airflow - Natural Gas and Propane Ratings on page 5. Do not operate outside these limits.

COOLING CAPACITIES, 2-STAGE COOLING, 25 TONS (cont)

TEMP (F) AIR ENTERING CONDENSER (Edb)		25 TONS - UNIT WITH HOT GAS RE-HEAT IN SUBCOOLING MODE								
		Air Entering Evaporator - CFM								
		7,500			10,000			12,500		
		Air Entering Evaporator - Ewb (F)								
		72	67	62	72	67	62	72	67	62
75	TC	335.30	305.50	275.80	368.30	334.40	300.50	398.10	360.50	322.90
	SHC	149.60	181.70	213.70	172.80	205.50	238.20	191.70	224.90	258.20
	kW	19.50	18.70	17.70	19.50	18.70	17.70	19.70	18.80	17.90
85	TC	316.30	287.00	257.70	341.50	308.40	275.30	364.30	327.80	291.20
	SHC	120.80	160.50	200.20	144.60	185.20	225.80	164.00	205.40	246.70
	kW	21.90	21.30	20.10	22.30	21.30	20.30	22.50	21.70	20.60
95	TC	297.30	268.50	239.60	314.70	282.40	250.10	330.50	295.00	259.50
	SHC	92.10	139.40	186.70	116.40	164.90	213.50	136.30	185.80	235.30
	kW	24.30	23.50	22.50	24.40	23.50	22.60	24.40	23.60	22.50
105	TC	278.20	249.90	221.60	287.90	256.40	224.90	296.70	262.30	227.80
	SHC	63.30	118.20	173.20	88.30	144.70	201.10	108.70	166.30	223.90
	kW	26.70	26.00	25.00	27.30	26.00	25.00	27.30	26.10	25.10
115	TC	259.20	231.40	203.50	261.10	230.40	199.70	262.90	229.50	196.10
	SHC	34.50	97.10	159.70	60.10	124.40	188.70	81.00	146.70	191.20
	kW	28.70	28.00	27.10	29.30	28.10	26.90	29.10	27.90	27.20

TEMP (F) AIR ENTERING CONDENSER (Edb)		25 TONS - UNIT WITH HOT GAS RE-HEAT IN HOT GAS REHEAT MODE								
		Air Entering Evaporator (F)								
		75 Dry Bulb			75 Dry Bulb			75 Dry Bulb		
		62.5 Wet Bulb			64 Wet Bulb			65.3 Wet Bulb		
		(50% Relative)			(56% Relative)			(60% Relative)		
		Air Entering Evaporator - CFM								
		7,500	10,000	12,500	7,500	10,000	12,500	7,500	10,000	12,500
80	TC	132.40	136.80	148.40	138.20	142.40	154.60	144.30	146.40	162.50
	SHC	37.80	61.50	85.50	21.80	44.40	52.40	16.10	32.10	48.90
	kW	17.90	18.15	18.21	18.05	18.33	18.43	18.26	18.55	18.62
75	TC	138.00	142.20	154.10	143.50	148.00	160.30	148.90	151.00	167.10
	SHC	44.20	68.00	91.80	28.10	51.50	58.80	22.70	38.20	56.00
	kW	17.77	18.00	18.07	17.92	18.19	18.29	18.14	18.40	18.48
70	TC	143.80	148.10	160.00	149.30	154.00	165.90	155.50	157.60	173.80
	SHC	50.50	73.80	98.10	34.20	56.50	65.30	28.30	44.00	62.30
	kW	17.63	17.86	17.93	17.78	18.04	18.14	18.03	18.26	18.34
60	TC	154.80	159.50	171.10	160.20	165.20	177.20	166.70	168.80	185.10
	SHC	63.10	84.50	110.10	46.50	69.50	75.70	41.40	56.50	74.30
	kW	17.35	17.58	17.65	17.50	17.76	17.85	17.70	17.97	18.04
50	TC	166.30	170.50	181.20	171.30	176.40	188.40	178.00	180.00	196.40
	SHC	75.80	96.50	122.20	58.30	79.80	87.80	53.70	69.10	85.90
	kW	17.06	17.30	17.37	17.22	17.46	17.56	17.42	17.69	17.76
40	TC	177.50	181.70	192.30	182.40	187.60	199.70	189.30	191.20	207.70
	SHC	85.70	109.80	134.30	71.50	92.30	100.50	66.10	79.50	97.90
	kW	16.76	17.01	17.09	16.93	17.18	17.28	17.14	17.41	17.47

LEGEND

- Edb** — Entering Dry-Bulb
- Ewb** — Entering Wet-Bulb
- kW** — Compressor Motor Power Input
- ldb** — Leaving Dry-Bulb
- lwb** — Leaving Wet-Bulb
- SHC** — Sensible Heat Capacity (1000 Btuh) Gross
- TC** — Total Capacity (1000 Btuh) Gross

NOTES:

1. Direct interpolation is permissible. Do not extrapolate.
2. The following formulas may be used:

$$t_{ldb} = t_{edb} - \frac{\text{sensible capacity (Btuh)}}{1.10 \times \text{cfm}}$$

$$t_{lwb} = \text{Wet-bulb temperature corresponding to enthalpy of air leaving evaporator coil } (h_{lwb})$$

$$h_{lwb} = h_{ewb} - \frac{\text{total capacity (Btuh)}}{4.5 \times \text{cfm}}$$

Where: h_{ewb} = Enthalpy of air entering evaporator coil

CAPACITY RATINGS (CONT)

COOLING CAPACITIES, 2-STAGE COOLING, 27.5 TONS

RGS336				AMBIENT TEMPERATURE (F)												
				85			95			105			115			
				EAT (db)			EAT (db)			EAT (db)			EAT (db)			
				75	80	85	75	80	85	75	80	85	75	80	85	
7,500 Cfm	EAT (wb)	58	THC	298.0	298.0	336.8	285.3	285.3	322.4	270.1	270.1	305.3	253.5	253.5	286.5	
			SHC	259.2	298.0	336.8	248.2	285.3	322.4	235.0	270.1	305.3	220.5	253.5	286.5	
		62	THC	318.3	318.3	318.3	301.9	301.9	309.0	282.4	282.4	299.5	260.5	260.5	288.5	
			SHC	233.5	275.2	316.9	225.8	267.4	309.0	216.6	258.1	299.5	206.1	247.3	288.5	
		67	THC	352.3	352.3	352.3	335.9	335.9	335.9	317.1	317.1	317.1	294.0	294.0	294.0	
			SHC	193.3	235.0	276.8	186.4	228.3	270.1	178.7	220.5	262.4	169.3	211.1	252.9	
	72	THC	383.6	383.6	383.6	368.5	368.5	368.5	350.7	350.7	350.7	329.6	329.6	329.6		
		SHC	149.7	191.9	234.2	144.0	186.2	228.4	137.3	179.5	221.7	129.6	171.7	213.8		
	76	THC	—	404.0	404.0	—	390.3	390.3	—	373.1	373.1	—	353.4	353.4		
		SHC	—	154.8	200.2	—	150.2	195.6	—	144.5	189.9	—	138.0	183.2		
	8,750 Cfm	EAT (wb)	58	THC	315.7	315.7	356.8	302.4	302.4	341.8	286.8	286.8	324.1	269.2	269.2	304.3
				SHC	274.6	315.7	356.8	263.0	302.4	341.8	249.4	286.8	324.1	234.2	269.2	304.3
62			THC	329.7	329.7	346.7	312.7	312.7	338.3	293.0	293.0	328.0	271.1	271.1	314.6	
			SHC	251.3	299.0	346.7	243.3	290.8	338.3	233.7	280.9	328.0	222.0	268.3	314.6	
67			THC	363.1	363.1	363.1	346.4	346.4	346.4	327.1	327.1	327.1	303.7	303.7	303.7	
			SHC	204.4	252.2	299.9	197.8	245.7	293.6	190.2	238.3	286.3	181.0	229.1	277.2	
72		THC	392.4	392.4	392.4	377.4	377.4	377.4	359.5	359.5	359.5	338.6	338.6	338.6		
		SHC	153.8	201.6	249.3	148.4	196.3	244.3	141.9	190.0	238.0	134.5	182.7	230.8		
76		THC	—	410.9	410.9	—	397.4	397.4	—	380.0	380.0	—	359.9	359.9		
		SHC	—	160.7	213.6	—	156.2	208.9	—	150.1	201.8	—	143.2	194.1		
10,000 Cfm		EAT (wb)	58	THC	330.4	330.4	373.4	316.6	316.6	357.8	300.7	300.7	339.9	282.3	282.3	319.0
				SHC	287.4	330.4	373.4	275.4	316.6	357.8	261.6	300.7	339.9	245.6	282.3	319.0
	62		THC	338.9	338.9	373.5	321.8	321.8	364.5	301.9	301.9	354.3	282.6	282.6	331.6	
			SHC	267.2	320.3	373.5	258.9	311.7	364.5	249.5	301.9	354.3	233.5	282.6	331.6	
	67		THC	371.1	371.1	371.1	354.3	354.3	354.3	334.7	334.7	334.7	310.9	310.9	310.9	
			SHC	214.5	267.9	321.3	208.2	262.0	315.7	200.9	254.9	308.9	191.9	246.0	300.1	
	72	THC	398.6	398.6	398.6	383.8	383.8	383.8	365.7	365.7	365.7	344.9	344.9	344.9		
		SHC	157.3	210.1	262.8	152.2	205.4	258.7	145.8	199.4	252.9	138.7	192.5	246.3		
	76	THC	—	415.7	415.7	—	402.3	402.3	—	384.9	384.9	—	364.5	364.5		
		SHC	—	165.2	223.6	—	160.5	218.0	—	154.6	211.3	—	147.8	203.9		
	11,250 Cfm	EAT (wb)	58	THC	342.7	342.7	387.3	328.7	328.7	371.4	312.7	312.7	353.3	293.5	293.5	331.7
				SHC	298.1	342.7	387.3	285.9	328.7	371.4	272.0	312.7	353.3	255.3	293.5	331.7
62			THC	346.8	346.8	396.7	329.7	329.7	387.0	313.0	313.0	367.3	293.8	293.8	344.8	
			SHC	281.1	338.9	396.7	272.5	329.7	387.0	258.6	313.0	367.3	242.8	293.8	344.8	
67			THC	377.2	377.2	377.2	360.4	360.4	360.4	340.7	340.7	340.7	316.6	316.6	321.8	
			SHC	223.7	282.5	341.2	217.9	277.2	336.5	210.8	270.5	330.2	202.1	261.9	321.8	
72		THC	403.1	403.1	403.1	388.6	388.6	388.6	370.3	370.3	370.3	349.5	349.5	349.5		
		SHC	160.3	217.7	275.1	155.5	213.7	271.9	149.3	208.0	266.7	142.4	201.4	260.5		
76		THC	—	419.3	419.3	—	406.0	406.0	—	388.5	388.5	—	367.8	367.8		
		SHC	—	168.8	231.3	—	164.4	226.3	—	158.6	220.0	—	151.9	212.8		
12,500 Cfm		EAT (wb)	58	THC	353.0	353.0	398.9	338.8	338.8	382.9	322.5	322.5	364.5	303.1	303.1	342.5
				SHC	307.1	353.0	398.9	294.7	338.8	382.9	280.6	322.5	364.5	263.7	303.1	342.5
	62		THC	353.9	353.9	415.3	339.1	339.1	397.9	322.8	322.8	378.9	303.4	303.4	356.0	
			SHC	292.4	353.9	415.3	280.2	339.1	397.9	266.8	322.8	378.9	250.7	303.4	356.0	
	67		THC	381.9	381.9	381.9	365.2	365.2	365.2	345.3	345.3	350.4	321.3	321.3	342.2	
			SHC	232.3	296.1	360.0	227.0	291.6	356.3	220.1	285.2	350.4	211.5	276.8	342.2	
	72	THC	406.6	406.6	406.6	392.2	392.2	392.2	373.9	373.9	373.9	352.9	352.9	352.9		
		SHC	163.1	224.8	286.6	158.5	221.4	284.3	152.5	216.1	279.6	145.7	209.8	273.9		
	76	THC	—	422.1	422.1	—	408.9	408.9	—	391.2	391.2	—	370.3	370.3		
		SHC	—	172.2	238.5	—	167.9	234.0	—	162.3	228.1	—	155.7	221.2		

LEGEND

- Do not operate
- Cfm** — Cubic feet per minute (supply air)
- EAT (db)** — Entering Air Temperature (dry bulb)
- EAT (wb)** — Entering Air Temperature (wet bulb)
- SHC** — Sensible Heat Capacity (1000 Btuh) Gross
- TC** — Total Capacity (1000 Btuh) Gross

NOTES:

1. See Minimum-Maximum Airflow - Natural Gas and Propane Ratings on page 5. Do not operate outside these limits.
2. Hot Gas Re-heat system available for 210-300 sizes only.

PHYSICAL DATA

PHYSICAL DATA (COOLING), 17.5-27.5 TONS, RTPF — ROUND TUBE/PLATE FIN COIL DESIGN

		RGS210	RGS210 w/Hot Gas Re-heat	RGS240	RGS240 w/Hot Gas Re-heat
Refrigeration System		RTPF	RTPF	RTPF	RTPF
# Circuits / # Comp. / Type		2 / 2 / Scroll	2 / 2 / Scroll	2 / 2 / Scroll	2 / 2 / Scroll
R-410A charge A/B (lbs)		16.3/17.5	25.9/25.7	20.6/14.7	27.9/20.5
Metering device		Accutrol*	TXV	Accutrol	TXV
High-press. Trip / Reset (psig)		630 / 505	630 / 505	630 / 505	630 / 505
Low-press. Trip / Reset (psig)		54 / 117	27 / 44	54 / 117	27 / 44
Evap. Coil					
Material		Cu / Al	Cu / Al	Cu / Al	Cu / Al
Tube Diameter (in.)		3/8	3/8	3/8	3/8
Rows / FPI		4 / 15	4 / 15	4 / 15	4 / 15
total face area (ft ²)		22.00	22.00	22.00	22.00
Condensate drain conn. size (in.)		3/4	3/4	3/4	3/4
Hot Gas Re-heat Coil					
Material		n/a	Cu / Al	n/a	Cu / Al
Tube Diameter		n/a	3/8"	n/a	3/8"
Rows / FPI		n/a	1 / 17	n/a	1 / 17
total face area (ft ²)		n/a	22.00	n/a	22.00
Evaporator Fan and Motor					
Standard Static	Motor Qty / Belt Qty / Driver Type	1/1/Belt	1/1/Belt	1/1/Belt	1/1/Belt
	Max BHP	3.7	3.7	4.9	4.9
	RPM range	622-822	622-822	690-863	690-863
	Max Blower/Shaft RPM	1200	1200	1200	1200
	motor frame size	56	56	56	56
	Fan Qty / Type	2 / Centrifugal	2 / Centrifugal	2 / Centrifugal	2 / Centrifugal
Medium Static	Fan Diameter (in.)	15 x 15	15 x 15	15 x 15	15 x 15
	Motor Qty / Belt Qty / Driver Type	1/1/Belt	1/1/Belt	n/a	n/a
	Max BHP	6.5/ 6.9/ 7.0/ 8.3	6.5/ 6.9/ 7.0/ 8.3	n/a	n/a
	RPM range	713-879	713-879	n/a	n/a
	Max Blower/Shaft RPM	1200	1200	n/a	n/a
	motor frame size	184T	184T	n/a	n/a
High Static	Fan Qty / Type	2 / Centrifugal	2 / Centrifugal	n/a	n/a
	Fan Diameter (in.)	15 x 15	15 x 15	n/a	n/a
	Motor Qty / Belt Qty / Driver Type	n/a	n/a	1/1/Belt	1/1/Belt
	Max BHP	n/a	n/a	6.5/ 6.9/ 7.0/ 8.3	6.5/ 6.9/ 7.0/ 8.3
	RPM range	n/a	n/a	835-1021	835-1021
	Max Blower/Shaft RPM	n/a	n/a	1200	1200
High Static - High Eff.	motor frame size	n/a	n/a	184T	184T
	Fan Qty / Type	n/a	n/a	2 / Centrifugal	2 / Centrifugal
	Fan Diameter (in.)	n/a	n/a	15 x 15	15 x 15
	Motor Qty / Belt Qty / Driver Type	1/1/Belt	1/1/Belt	1/1/Belt	1/1/Belt
	Max BHP (208/230/460/575v)	6.5/ 6.9/ 7.0/ 8.3	6.5/ 6.9/ 7.0/ 8.3	10.5/11.9/11.9/11	10.5/11.9/11.9/11
	RPM range	882-1078	882-1078	941-1176	941-1176
High Static - High Eff.	Max Blower/Shaft RPM	1200	1200	1200	1200
	motor frame size	184T	184T	213T	213T
	Fan Qty / Type	2 / Centrifugal	2 / Centrifugal	2 / Centrifugal	2 / Centrifugal
	Fan Diameter (in.)	15 x 15	15 x 15	15 x 15	15 x 15

* Accutrol is a trademark of Accutrol LLC.

PHYSICAL DATA (CONT)

PHYSICAL DATA (COOLING), 17.5-27.5 TONS, RTPF — ROUND TUBE/PLATE FIN COIL DESIGN (cont)

		RGS300	RGS300 w/Hot Gas Re-Heat	RGS336
Refrigeration System		RTPF	RTPF	RTPF
# Circuits / # Comp. / Type		2 / 2 / Scroll	2 / 2 Scroll	2 / 2 Scroll
R-410A charge A/B (lbs)		19.8/20.4	27.9/28.9	27.0/28.5
Metering device		Accutrol	TXV	Accutrol
High-press. Trip / Reset (psig)		630 / 505	630 / 505	630 / 505
Low-press. Trip / Reset (psig)		54 / 117	27 / 44	54 / 117
Evap. Coil				
Material		Cu / Al	Cu / Al	Cu / Al
Tube Diameter (in.)		3/8	3/8	3/8
Rows / FPI		4 / 15	4 / 15	4 / 15
total face area (ft²)		23.11	23.11	26
Condensate drain conn. size (in.)		3/4	3/4	3/4
Hot Gas Re-heat Coil				
Material		n/a	Cu / Al	n/a
Tube Diameter		n/a	3/8"	n/a
Rows / FPI		n/a	1 / 17	n/a
total face area (ft²)		n/a	23.11	n/a
Evaporator Fan and Motor				
Standard Static	Motor Qty / Belt Qty / Driver Type	1/1/Belt	1/1/Belt	n/a
	Max BHP	4.9	4.9	n/a
	RPM range	717-911	717-911	n/a
	Max Blower/Shaft RPM	1200	1200	n/a
	motor frame size	56	56	n/a
	Fan Qty / Type	2 / Centrifugal	2 / Centrifugal	n/a
	Fan Diameter (in)	15 x 15	15 x 15	n/a
Standard Static - High Eff.	Motor Qty / Belt Qty / Driver Type	n/a	n/a	1/1/Belt
	Max BHP	n/a	n/a	6.5/ 6.9/ 7.0/ 8.3
	RPM range	n/a	n/a	751-954
	Max Blower/Shaft RPM	n/a	n/a	1300
	motor frame size	n/a	n/a	56
	Fan Qty / Type	n/a	n/a	2 / Centrifugal
Fan Diameter (in)	n/a	n/a	15 x 15	
Medium Static - High Eff.	Motor Qty / Belt Qty / Driver Type	1/1/Belt	1/1/Belt	1/1/Belt
	Max BHP	6.5/ 6.9/ 7.0/ 8.3	6.5/ 6.9/ 7.0/ 8.3	10.5/11.9/11.9/11
	RPM range (208/230/460/575v)	913-1116	913-1116	920-1190
	Max Blower/Shaft RPM	1200	1200	1300
	motor frame size	184T	184T	184T
	Fan Qty / Type	2 / Centrifugal	2 / Centrifugal	2 / Centrifugal
Fan Diameter (in)	15 x 15	15 x 15	15 x 15	
High Static - High Eff.	Motor Qty / Belt Qty / Driver Type	1/1/Belt	1/1/Belt	1/2/Belt
	Max BHP (208/230/460/575v)	10.5/11.9/11.9/11	10.5/11.9/11.9/11	11.9/12.9/12.9/14.1
	RPM range	941-1176	941-1176	1015-1299
	Max Blower/Shaft RPM	1200	1200	1300
	motor frame size	213T	213T	213T
	Fan Qty / Type	2 / Centrifugal	2 / Centrifugal	2 / Centrifugal
Fan Diameter (in)	15 x 15	15 x 15	15 x 15	

PHYSICAL DATA (COOLING), 17.5-27.5 TONS, RTPF — ROUND TUBE/PLATE FIN COIL DESIGN (cont)

		RGS210	RGS240	RGS300	RGS336
Condenser Coil (Circuit A)					
	Coil Type	RTPF	RTPF	RTPF	RTPF
	Coil length (in.)	70	82	75	95
	Coil height (in.)	44	44	52	52
	Rows / FPI	2/17	2/17	2/17	2/17
	Total face area (ft ²)	21.4	25.1	27.1	34.3
Condenser Coil (Circuit B)					
	Coil Type	RTPF	RTPF	RTPF	RTPF
	Coil length (in.)	70	57	75	95
	Coil height (in.)	44	44	52	52
	Rows / FPI	2/17	2/17	2/17	2/17
	Total face area (ft ²)	21.4	17.4	27.1	34.3
Condenser Fan/Motor					
	Qty/Motor drive type	3 / direct	4 / direct	4 / direct	6 / direct
	Motor HP / RPM	1/4 / 1100	1/4 / 1100	1/4 / 1100	1/4 / 1100
	Fan diameter (in)	22	22	22	22
Filters					
	RA filter #/ size (in.)	6 / 20 x 25 x 2	6 / 20 x 25 x 2	9 / 16 x 25 x 2	9 / 16 x 25 x 2
	OA inlet screen #/ size (in.)	4 / 16 x 25 x 1	4 / 16 x 25 x 1	4 / 16 x 25 x 1	4 / 16 x 25 x 1
Gas Connection					
	# of Gas Valves	1	1	1	1
	Natural gas supply line press (in. wg) / (PSIG)	5-13 / 0.18-0.47	5-13 / 0.18-0.47	5-13 / 0.18-0.47	5-13 / 0.18-0.47
	LP supply line pressure (in. wg) / (PSIG)	11-13 / 0.40-0.47	11-13 / 0.40-0.47	11-13 / 0.40-0.47	11-13 / 0.40-0.47
Heat Anticipator setting (Amps)					
	1 st stage	0.14	0.14	0.14	0.14
	2 nd stage	0.14	0.14	0.14	0.14
Natural Gas Heat					
LOW	# of stages / # of burners (total)	2 / 5	2 / 5	2 / 5	2 / 5
	Connection size (in.)	3/4 NPT	3/4 NPT	3/4 NPT	3/4 NPT
	Rollout switch opens / closes (F)	195 / 115	195 / 115	195 / 115	195 / 115
	Temperature Rise (F)	25-55	25-55	25-55	25-55
MED	# of stages / # of burners (total)	2 / 7	2 / 7	2 / 7	2 / 7
	Connection size (in.)	3/4 NPT	3/4 NPT	3/4 NPT	3/4 NPT
	Rollout switch opens / closes (F)	195 / 115	195 / 115	195 / 115	195 / 115
	Temperature Rise (F)	30-60	30-60	30-60	30-60
HIGH	# of stages / # of burners (total)	2 / 10	2 / 10	2 / 10	2 / 10
	Connection size (in.)	3/4 NPT	3/4 NPT	3/4 NPT	3/4 NPT
	Rollout switch opens / closes (F)	195 / 115	195 / 115	195 / 115	195 / 115
	Temperature Rise (F)	35-65	35-65	35-65	35-65

PHYSICAL DATA (CONT)

PHYSICAL DATA (HEATING), 17.5-27.5 TONS

		RGS210	RGS240	RGS300	RGS336
Liquid Propane Heat					
LOW	# of stages / # of burners (total)	2 / 5	2 / 5	2 / 5	2 / 5
	Connection size (in.)	3/4 NPT	3/4 NPT	3/4 NPT	3/4 NPT
	Rollout switch opens / closes (F)	195 / 115	195 / 115	195 / 115	195 / 115
	Temperature Rise (F)	25-55	25-55	25-55	25-55
MED	# of stages / # of burners (total)	2 / 7	2 / 7	2 / 7	2 / 7
	Connection size (in.)	3/4 NPT	3/4 NPT	3/4 NPT	3/4 NPT
	Rollout switch opens / closes (F)	196 / 115	197 / 115	198 / 115	198 / 115
	Temperature Rise (F)	30-60	30-60	30-60	30-60
HIGH	# of stages / # of burners (total)	2 / 10	2 / 10	2 / 10	2 / 10
	Connection size (in.)	3/4 NPT	3/4 NPT	3/4 NPT	3/4 NPT
	Rollout switch opens / closes (F)	195 / 115	195 / 115	195 / 115	195 / 115
	Temperature Rise (F)	35-65	35-65	35-65	35-65

OPTIONS AND ACCESSORIES

FACTORY-INSTALLED AND FIELD-INSTALLED ACCESSORIES

CATEGORY	ITEM	FACTORY INSTALLED OPTION	FIELD INSTALLED ACCESSORY
Cabinet	Hinged access panels	X	
Coil Options	Cu/Cu outdoor & indoor coils	X	
	E-coated outdoor & indoor coils	X	
	Pre-coated outdoor coils	X	
Humidity Control	Hot Gas Re-heat	X	
Condenser Protection	Condenser coil hail guard (louvered design)	X	X
Controls	Smoke detector	X	X
	Time Guard II compressor delay control circuit		X
	Phase monitor		X
Economizers & Outdoor Air Dampers	EconoMi\$er® IV for electro-mechanical controls Non FDD (Standard air leak damper models) ^{5, 7}	X	X
	EconoMi\$er X for electro-mechanical controls, complies with FDD. (Standard and Ultra Low Leak air damper models) ⁵	X	X
	Motorized 2 position outdoor-air damper ⁷	X	X
	Manual outdoor-air damper (25%) ⁷	X	X
	Barometric relief ¹	X	X
	Power exhaust—centrifugal blower	X	X
Economizer Sensors & IAQ Devices	Single dry bulb temperature sensors ²	X	X
	Single enthalpy sensors ²	X	X
	Differential enthalpy sensors ²		X
	Wall or duct mounted CO ₂ sensor ²		X
	Unit mounted CO ₂ sensor ²	X	
	4-in filter track assembly		X
Gas Heat	Propane conversion kit		X
	Stainless steel heat exchanger	X	
	High altitude conversion kit		X
	Flue discharge deflector		X
Indoor Motor & Drive	Multiple motor and drive packages	X	
	2-Speed Indoor Fan Motor system	X	
	Display Kit for 2-Speed Indoor Fan Motor system		X
Low Ambient Control	Winter start kit ³		X
	Motormaster® head pressure controller to -20°F (-29°C) ³		X
Power Options	Convenience outlet (powered)	X	
	Convenience outlet (unpowered): 15 amp factory-installed, 20 amp field-installed	X	X
	Non-fused disconnect ⁴	X	
Roof Curbs	Roof curb 14-in (356 mm)		X
	Roof curb 24-in (610 mm)		X

NOTES:

1. Included with economizer.
2. Sensors used to optimize economizer performance.
3. See application data for assistance.
4. Non-fused disconnect switch cannot be used when unit FLA rating exceeds 200 amps on 208/230 volt and 100 amps on 460/575 volt units.
5. FDD (Fault Detection and Diagnostic) capability per California Title 24 Section 120.2i, ASHRAE 90.1-2016 and IECC-2015 Fault Detection and Diagnostic (FDD) requirements.
6. Requires a field-supplied 24V transformer for each application. See price pages for details.
7. Not available on units with 2-Speed Indoor Fan Motor system.

OPTIONS AND ACCESSORIES (CONT)

Economizer (dry-bulb or enthalpy)

Economizers can reduce operating costs. They bring in fresh, outside air for ventilation; and provide cool outside air to cool your building. This also is the preferred method of low ambient cooling. When coupled to CO₂ sensors, economizers can limit the ventilation air to only that amount required.

Economizers are available, installed and tested by the factory, with either enthalpy or temperature dry-bulb inputs. There are also models for electro-mechanical, direct digital controllers and single speed fan or 2-speed indoor fan motors. Additional sensors are available as accessories to optimize the economizer.

Economizers include gravity controlled barometric relief that helps equalize building pressure and ambient air pressures. This can be a cost effective solution to prevent building pressurization. Economizers are available in Ultra Low Leak and standard low leak versions.

CO₂ sensor

The CO₂ sensor works with the economizer to intake only the correct amount of outside air for ventilation. As occupants fill your building, the CO₂ sensor detects their presence through increasing CO₂ levels, and opens the economizer appropriately.

When the occupants leave, the CO₂ levels decrease, and the sensor appropriately closes the economizer. This intelligent control of the ventilation air, called Demand Controlled Ventilation (DCV) reduces the overall load on the rooftop, saving money.

Smoke detectors

Trust the experts. Smoke detectors make your application safer and your job easier. Smoke detectors immediately shut down the rooftop unit when smoke is detected. They are available for supply air.

Louvered hail guards

Sleek, louvered panels protect the condenser coil from hail damage, foreign objects, and incidental contact.

Convenience outlet (powered or un-powered)

Reduce service and/or installation costs by including a convenience outlet in your specification. The convenience outlet provides 15 amp, 115v GFCI receptacle with "Wet in Use" cover. The "powered" option allows the installer to power the outlet from the line side of the disconnect side as required by code. The "un-powered" option is to be powered from a separate (non-unit) 115/120v power source. The unpowered convenience outlet is available as a 15 amp factory-installed option or a 20 amp field-installed accessory.

The 20 amp unpowered convenience outlet kit provides a flexible installation method which allows code compliance for height requirements of the GFCI outlet from the finished roof surface as well as the capability to relocate the outlet to a more convenient location, if necessary.

Non-fused disconnect

This OSHA-compliant, factory-installed, safety switch allows a service technician to locally secure power to the rooftop.

When selecting a factory-installed non-fused disconnect, note they are sized for unit as ordered from the factory. The sizing of these does not accommodate any power exhaust devices, etc.

Power exhaust with barometric relief

Superior internal building pressure control. This field- installed accessory or factory-installed option may eliminate the need for costly, external pressure control fans.

Time guard II control circuit

This accessory protects your compressor by preventing short-cycling in the event of some other failure, prevents the compressor from restarting for 30 seconds after stopping.

Hot Gas Re-heat

Hot Gas Re-heat is an all-inclusive factory-installed option that can be ordered with RGS units.

This system expands the envelope of operation of rooftop products to provide unprecedented flexibility to meet year round comfort conditions.

The Hot Gas Re-heat has a unique dual operational mode setting. The Hot Gas Re-heat includes two new modes of operation.

RGS rooftop coupled with the Hot Gas Re-heat is capable of operating in normal design cooling mode, subcooling mode, and hot gas reheat mode. Normal design cooling mode is when the unit will operate under its normal sequence of operation by cycling compressors to maintain comfort conditions.

Subcooling mode will operate to satisfy part load type conditions when the space requires combined sensible and a higher proportion of latent load control. Hot Gas Reheat mode will operate when outdoor temperatures diminish and the need for latent capacity is required for sole humidity control. Hot Gas Reheat mode will provide neutral air for maximum dehumidification operation.

Motorized 2-position damper

The new 2-position, motorized outdoor air damper admits up to 100% outside air. Using reliable, gear-driven technology, the 2-position damper opens to allow ventilation air and closes when the rooftop stops, stopping unwanted infiltration.

Manual OA damper

Manual outdoor air dampers are an economical way to bring in ventilation air. The dampers are available in 25% versions.

2-Speed Indoor Fan Speed System

The 2-Speed Indoor Fan Motor system saves energy and installation time by utilizing a Variable Frequency Drive (VFD) to automatically adjust the indoor fan motor speed in sequence with the units cooling operation. Per ASHRAE 90.1-2016 and IECC-2015 standards, during the first stage of cooling operation the VFD will adjust the fan motor to provide 66% of the total cfm established for the unit. When a call for the second stage of cooling is required, the VFD will allow the total cfm for the unit established (100%). During the heating mode the VFD will allow total design cfm (100%) operation and during the ventilation mode the VFD will allow operation to 66% of total cfm.

Compared to single speed indoor fan motor systems, the 2-Speed Indoor Fan Motor system can save substantial energy, 25%+ versus single speed indoor fan motor systems.

The VFD used in 2-Speed Indoor Fan Motor system has soft start capabilities to slowly ramp up the speeds, thus eliminating any high inrush air volume during initial start-up. It also has

internal over current protection for the fan motor and a field-installed display kit that allows adjustment and in depth diagnostics of the VFD.

This 2-Speed Indoor Fan Motor system is available on models with 2-stage cooling operation with electrical mechanical or Multi Protocol controls. Both space sensor and conventional thermostats controls can be used to provide accurate control in any application.

The 2-Speed Indoor Fan Motor system is very flexible for initial fan performance set up and adjustment. The standard factory shipped VFD is preprogrammed to automatically stage the fan speed between the first and second stage of cooling. The unit fan performance static pressure and cfm can be easily adjusted using the traditional means of pulley adjustments. The other means to adjust the unit static and cfm performance is to utilize the field-installed Display Kit and adjust the frequency and voltage in the VFD to required performance requirements. In either case, once set up, the VFD will automatically adjust the speed between the cooling stage operations.

Motormaster® head pressure controller

The Motormaster motor controller is a low ambient, head pressure controller kit that is designed to maintain the unit's condenser head pressure during periods of low ambient cooling operation. This device should be used as an alternative to economizer free cooling when economizer usage is either not appropriate or desired. The Motormaster will either cycle the outdoor-fan motors or operate them at reduced speed to maintain the unit operation, depending on the model.

Winter start kit

The winter start kit by extends the low ambient limit of your rooftop to 25°F (-4°C). The kit bypasses the low pressure switch, preventing nuisance tripping of the low pressure switch. Other low ambient precautions may still be prudent.

Motormaster allows cooling operation down to -20°F (-29°C) ambient conditions.

Propane heating

Convert your gas heat rooftop from standard natural gas operation to Propane using this field-installed kit.

High altitude heating

High altitudes have less oxygen, which means heat exchangers need less fuel. The new gas orifices in this field-installed kit make the necessary adjustment for high altitude applications. They restore the optimal fuel to air mixture and maintain healthy combustion at altitudes above 2000 ft (610 m). Kits may not be required in all areas.

Optional stainless steel heat exchanger

The stainless steel heat exchanger option provides the tubular heat exchanger be made out of a minimum 20 gauge type 409 stainless steel for applications where the mixed air to the heat exchanger is expected to drop below 45°F (7°C). Stainless steel may be specified on applications where the presence of airborne contaminants require its use (applications such as paper mills) or in area with very high outdoor humidity that may result in severe condensation in the heat exchanger during cooling operation.

Flue discharge deflector

The flue discharge deflector is a useful accessory when flue gas recirculation is a concern. By venting the flue discharge upwards, the deflector minimizes the chance for a neighboring unit to intake the flue exhaust.

Hinged access panels

Allows access to unit's major components with specifically designed hinged access panels. Panels are: filter, control box, and fan motor.

OPTIONS AND ACCESSORIES — WEIGHT ADDERS

BASE UNIT WITH OPTIONS AND ACCESSORIES (Weight Adders)	MAX WEIGHT ADDER							
	210		240		300		336	
	lb	kg	lb	kg	lb	kg	lb	kg
Hot Gas ReHeat ¹	120	55	120	55	120	55	—	—
Power Exhaust	125	57	125	57	125	57	125	57
EconoMi\$er® (IV or X)	246	112	246	112	246	112	246	112
Cu/Cu Condenser Coil ²	28	13	30	14	34	15	34	15
Cu/Cu Condenser and Evaporator Coils ²	53	24	58	26	64	29	64	29
Medium Gas Heat	90	41	90	41	90	41	90	41
High Gas Heat	113	51	113	51	113	51	113	51
Flue Discharge Deflector	7	3	7	3	7	3	7	3
Roof Curb 14-in. (356 mm)	240	109	255	116	255	116	255	116
Roof Curb 24-in. (610 mm)	340	154	355	161	355	161	355	161
Louvered Hail Guard	60	27	120	54	150	68	150	68
CO ₂ Sensor	5	2	5	2	5	2	5	2
Return Smoke Detector	5	2	5	2	5	2	5	2
Supply Smoke Detector	5	2	5	2	5	2	5	2
Fan/Filter Status Switch	2	1	2	1	2	1	2	1
Non-Fused Disconnect	15	7	15	7	15	7	15	7
Powered Convenience Outlet	35	16	35	16	35	16	35	16
Non-Powered Convenience Outlet	5	2	5	2	5	2	5	2
Enthalpy Sensor	2	1	2	1	2	1	2	1
Differential Enthalpy Sensor	3	1	3	1	3	1	3	1
Two Position Motorized Damper	50	23	50	23	65	29	65	29
Manual Damper	35	16	35	16	—	—	—	—
Field Filter Track 4-in. (102 mm)	22	10	22	10	22	10	22	10
Motormaster® Controller	35	16	35	16	35	16	35	16
Medium Static Motor/Drive	6	3	6	3	6	3	10	5
High Static Motor/Drive	12	5	16	7	16	7	20	9
2-Speed Indoor Fan Motor System with VFD	20	9	20	9	20	9	20	9

NOTES:

1. For Hot Gas ReHeat add Motormaster Controller.
2. Where available

— Not available

ACCESSORIES - RGS210-336

→

ECONOMIZERS ^{1, 2}		
Model Number	Description	Use With Model Size
CRECOMZR052A00 ³	Low Leak vertical EconoMi\$er IV ³ with solid-state controller, gear-driven, modulating damper, spring return actuator, up to 100% barometric relief, supply and outdoor air sensors and outdoor air hood. CO ₂ sensor compatible.	210 - 240
CRECOMZR053A00 ³	Low Leak vertical EconoMi\$er IV with solid-state controller, gear-driven, modulating damper, spring return actuator, up to 100% barometric relief, supply and outdoor air sensors and outdoor air hood. CO ₂ sensor compatible.	300 - 336
CRECOMZR074A00	Ultra Low Leak Vertical Economizer X with solid-state controller, gear-driven, fully modulating damper, spring return actuator, up to 100% barometric relief, supply and outdoor air sensors, and CO ₂ sensor compatible.	210 - 240
CRECOMZR075A00	Ultra Low Leak Vertical Economizer X with solid-state controller, gear-driven, fully modulating damper, spring return actuator, up to 100% barometric relief, supply and outdoor air sensors, and CO ₂ sensor compatible.	300 - 336

¹ Economizer X cannot be installed with Economizer IV, manual damper, or motorized damper.

² Can only be used on electrical mechanical units with 2-stage cooling and 2-speed fan control.

³ Economizer IV can be used when following the guidelines in Application Tip "AB-18-0002".

ECONOMIZER SENSORS		
Model Number	Description	Use With Model Size
DNTEMPSN002A00	Single (dry bulb) Control	Economizers IV
DNCBIOX005A00	CO ₂ Sensor and aspirator box for use in return air stream.	Economizers IV & X
DNENTDIF004A00	Return Air Enthalpy Sensor	Economizers IV
AXB078ENT	Enthalpy Control	Economizers IV
CRTEMPSN005A00	Outdoor or return dry bulb temperature sensor used with Honeywell W7220 electro-mechanical control.	Economizer X
--HH--57AC-081	Enthalpy control for W7220 controller only. (One required for single enthalpy, two required for differential enthalpy)	Economizer X

NOTE: Supply air temperature sensor (SAT and low ambient lockout switch) provided with economizer IV or economizer X.

POWER EXHAUST		
Model Number	Description	Use With Model Size*
CRPWREXH068A00	Vertical, 208/230-3-60	ALL
CRPWREXH069A00	Vertical, 460-3-60	ALL
CRPWREXH070A00	Vertical, 460-3-60	ALL

*Power exhaust can be used with both Economizer IV and Economizer X. The power exhaust is controlled by the Economizer controller.

MANUAL OUTDOOR AIR DAMPERS		
Model Number	Description	Use With Model Size
CRMANDPR009A00	25% Open Manual Fresh Air Damper	210 - 240
CRMANDPR010A00	25% Open Manual Fresh Air Damper	300 - 336

MOTORIZED OUTDOOR AIR DAMPERS		
Model Number	Description	Use With Model Size
CRTWOPOS012A00	Motorized 2 position outdoor air damper	210 - 240
CRTWOPOS013A00	Motorized 2 position outdoor air damper	300 - 336

LOW AMBIENT CONTROLS		
Model Number	Description	Use With Model Size
CRLOWAMB041A00 ¹	Motormaster® I -20° Low Ambient Control 208/230-3-60	210-240-300-336
CRLOWAMB042A00 ¹	Motormaster® I -20° Low Ambient Control 460-3-60, 575-3-60	210-240-300-336
CRTRXKIT001A00	Motormaster® I -20° Transformer 575-3-60 Must be used in conjunction with Low Ambient Controller if used on 575-3-60 models.	210-240-300-336

¹ Also requires one DNWINSTR001A00 winter start kit per circuit.

ACCESSORIES - RGS210-336 (CONT)

FLAT ROOF CURBS		
Model Number	Description	Use With Model Size
CRRFCURB045A00	14 in. (356 mm) High Roof Curb. Ductwork attaches to the roof curb. Includes thru-the-bottom capability.	210
CRRFCURB047A00		240 - 300
CRRFCURB049A00		336
CRRFCURB046A00	24 in. (607 mm) High Roof Curb. Ductwork attaches to the roof curb. Includes thru-the-bottom capability.	210
CRRFCURB048A00		240 - 300
CRRFCURB050A00		336
CONTROL UPGRADE KITS		
Model Number	Description	Use With Model Size
CRDISKIT001A00	VFD Remote keypad kit for replacement VFD drive module.	ALL
CRTIMEGD001A00	Time Guard II	ALL
CRSDTEST001A00	Smoke detector remote Test/Reset/Alarm indicator kit	ALL
CRPHASE3001A02	Electronic Phase Monitor - All 208/230/460-3-60 models	ALL
CRPHASE3002A00	Electronic Phase Monitor - All 575-3-60 models	ALL
CRSTATUS005A00	Fan/filter Status Switch - Indicator light not included	ALL
CRSMKSEN002A00	Smoke Detector Control Module	ALL
CRSMKKIT002A00	Smoke Detector Control Module (Smoke Detector Sensor with sampling tube and exhaust tube)	ALL
CRWINSTR001A00	Winter Start Kit - Contains time delay relay for timed bypass of low pressure switch on startup	ALL
PROPANE GAS CONVERSION KITS		
Model Number	Description	Use With Model Size
CRLPKIT9001A00	Propane Conversion kit. for use between 0' and 2,000'	ALL
CRLPELEV005A00	Propane and Hi Altitude conversion kit. for use between 2001' and 10,000'	ALL
CRLPELEV006A00	Propane and Hi Altitude conversion kit. for use between 10,001' and 14,000'	ALL
NATURAL GAS HIGH ALTITUDE CONVERSION KITS		
Model Number	Description	Use With Model Size
CRNGELEV001A00	High Altitude Conversion kit. for use between 3,000' and 10,000'	ALL
CRNGELEV002A00	High Altitude Conversion kit. for use between 10,001' and 14,000'	ALL
HEATING UPGRADE KITS		
Model Number	Description	Use With Model Size
CRFLUEDS006A00	Flue Discharge Deflector	ALL
4 IN. FILTER TRACK UPGRADE KIT		
Model Number	Description	Use With Model Size
CRFLTTRK001A00	4 in. Field Conversion Kit	ALL
LOUVERED HAIL GUARDS		
Model Number	Description	Use With Model Size
CRLVHLGD017A00	Louvered Condenser Coil Hail Guard	210
CRLVHLGD027A00	Louvered Condenser Coil Hail Guard	240
CRLVHLGD028A00	Louvered Condenser Coil Hail Guard	300
CRLVHLGD029A00	Louvered Condenser Coil Hail Guard	336

DIMENSIONS (CONT)

UNIT DIMENSIONAL DRAWING - RGS210 (cont)

UNIT	MAX. UNIT WEIGHT		CORNER WEIGHT (A)		CORNER WEIGHT (B)		CORNER WEIGHT (C)		CORNER WEIGHT (D)		C.G.								
	LBS.	KG.	LBS.	KG.	LBS.	KG.	LBS.	KG.	LBS.	KG.	X	Y	Z						
RGS210	2175	987	517	235	528	240	571	259	559	254	44	3/4	[11377]	4	3/4	[1645]	16	1/2	[419]

* STANDARD UNIT WEIGHT IS WITH LOW GAS HEAT AND WITHOUT PACKAGING.
FOR OTHER OPTIONS AND ACCESSORIES, REFER TO THE PRODUCT DATA CATALOG.

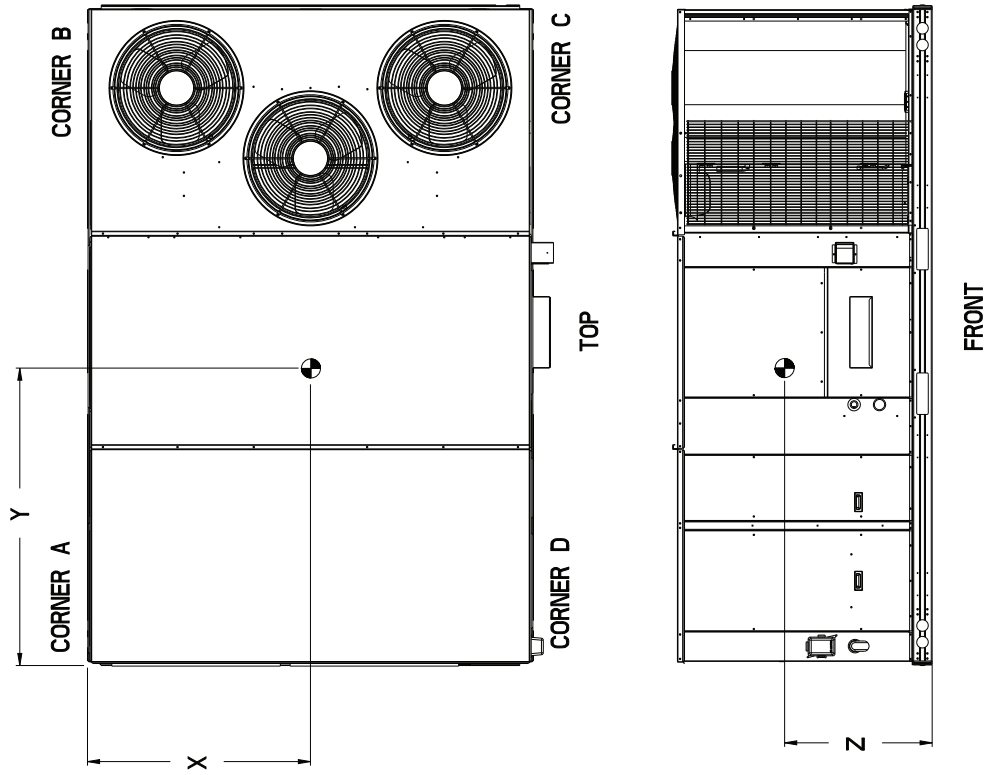

UNIT DIMENSIONAL DRAWING - RGS240-300

CONNECTION SIZES	
A	1 3/8" DIA [35] FIELD POWER SUPPLY KNOCKOUT
B	3" DIA [76] FIELD POWER SUPPLY KNOCKOUT
C	3 5/8" DIA [92] FIELD POWER SUPPLY KNOCKOUT
D	7/8" DIA [22] FIELD CONTROL WIRING HOLE
E	3/4" x 1/4" NPT CONDENSATE DRAIN
F	3/4" x 1/4" NPT GAS CONNECTION (NOT SHOWN)
G	7/8" DIA [22] FIELD CONTROL WIRING KNOCKOUT

UNIT	H
RGS240	49-3/8 [1253]
RGS300	57-3/8 [1438]

- NOTES:
1. DIMENSIONS ARE IN INCHES. DIMENSIONS IN () ARE IN MILLIMETERS.
 2. CENTER OF GRAVITY
 3. DIRECTION OF AIR FLOW

DEDICATED VERTICAL AIRFLOW UNIT 240, 300 SIZE

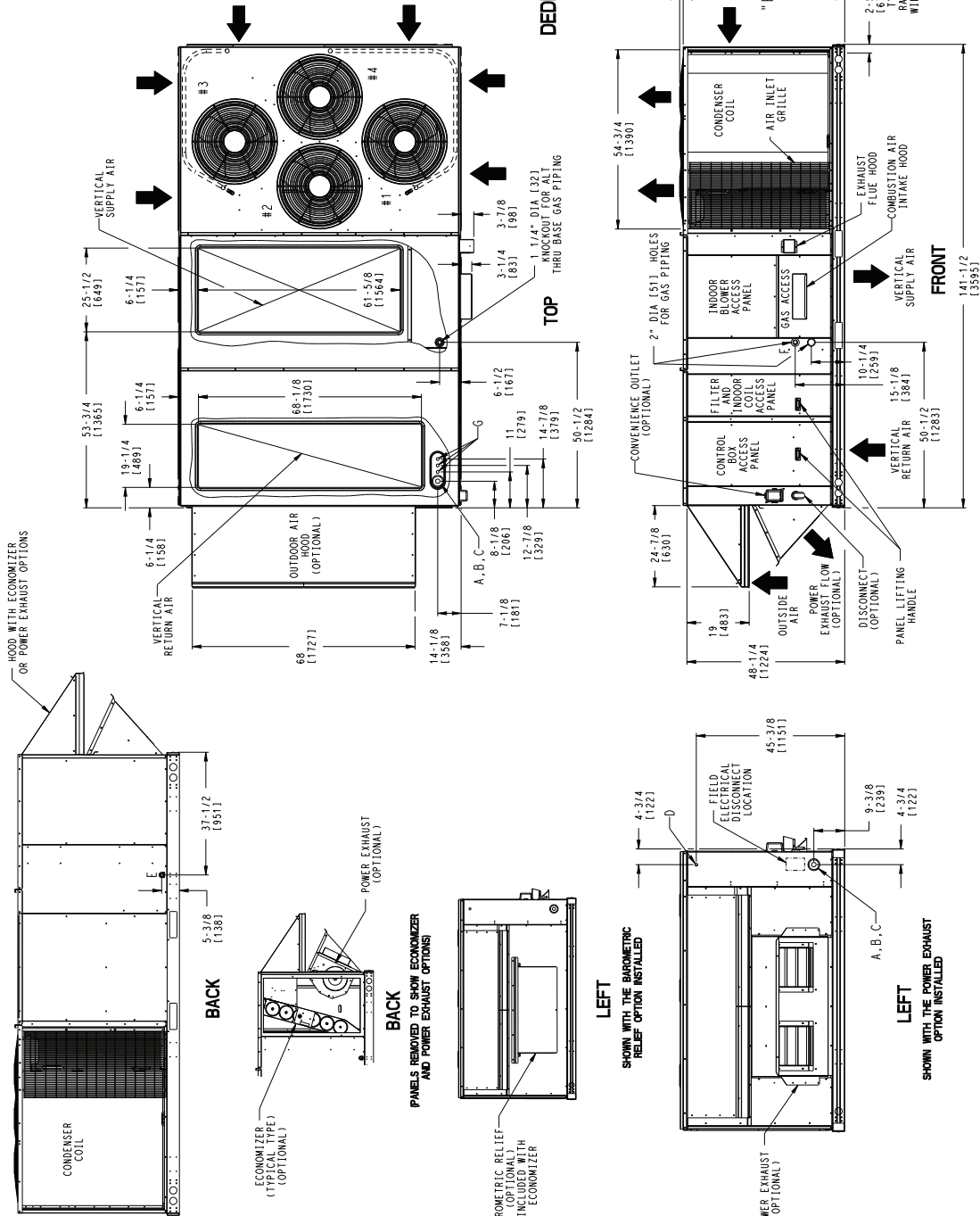

DIMENSIONS (CONT)

UNIT DIMENSIONAL DRAWING - RGS240-300 (cont)

UNIT	MAX. UNIT WEIGHT		CORNER WEIGHT (A)		CORNER WEIGHT (B)		CORNER WEIGHT (C)		CORNER WEIGHT (D)		C. G.					
	LBS.	KG.	LBS.	KG.	LBS.	KG.	LBS.	KG.	LBS.	KG.	X	Y	Z			
RGS240	2325	1055	448	203	631	286	728	330	517	235	46 1/8	111 7/2	82 7/8	2105	16 1/2	419
RGS300	2455	1114	473	215	666	302	769	349	546	248	46 1/8	111 7/2	82 7/8	2105	19	483

* STANDARD UNIT WEIGHT IS WITH LOW GAS HEAT AND WITHOUT PACKAGING.
FOR OTHER OPTIONS AND ACCESSORIES, REFER TO THE PRODUCT DATA CATALOG.

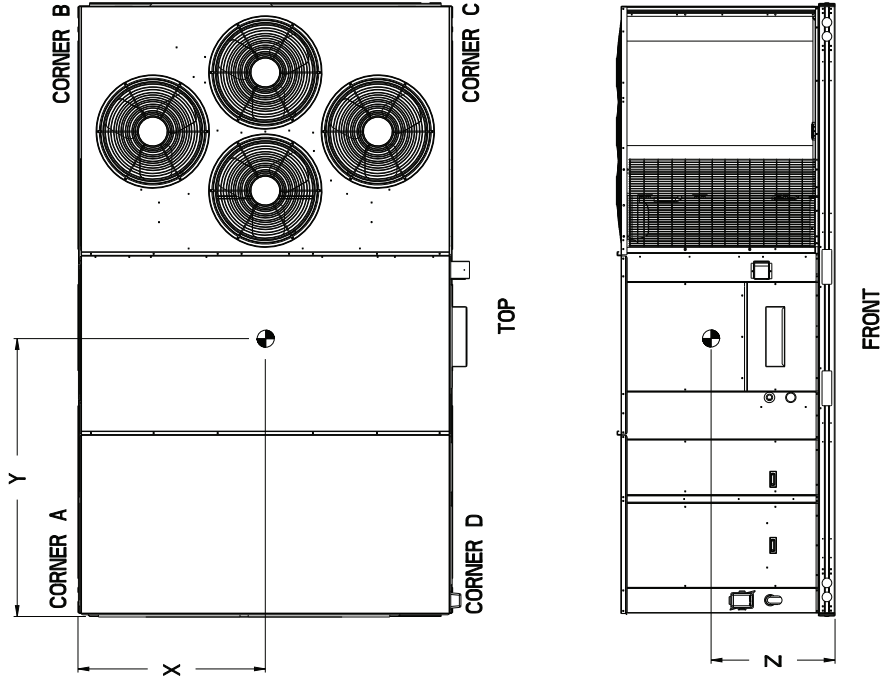

UNIT DIMENSIONAL DRAWING - RGS336

CONNECTION SIZES	
A	1 3/8" DIA [35] FIELD POWER SUPPLY KNOCKOUT
B	3" DIA [76] FIELD POWER SUPPLY KNOCKOUT
C	3 5/8" DIA [92] FIELD POWER SUPPLY KNOCKOUT
D	7/8" DIA [22] FIELD CONTROL WIRING HOLE
E	3/4"-1/4 NPT CONDENSATE DRAIN
F	3/4"-1/4 NPT GAS CONNECTION (NOT SHOWN)
G	7/8" DIA [22] FIELD CONTROL WIRING KNOCKOUT

- NOTES:
1. DIMENSIONS ARE IN INCHES, DIMENSIONS IN [] ARE IN MILLIMETERS.
 2. CENTER OF GRAVITY
 3. DIRECTION OF AIR FLOW

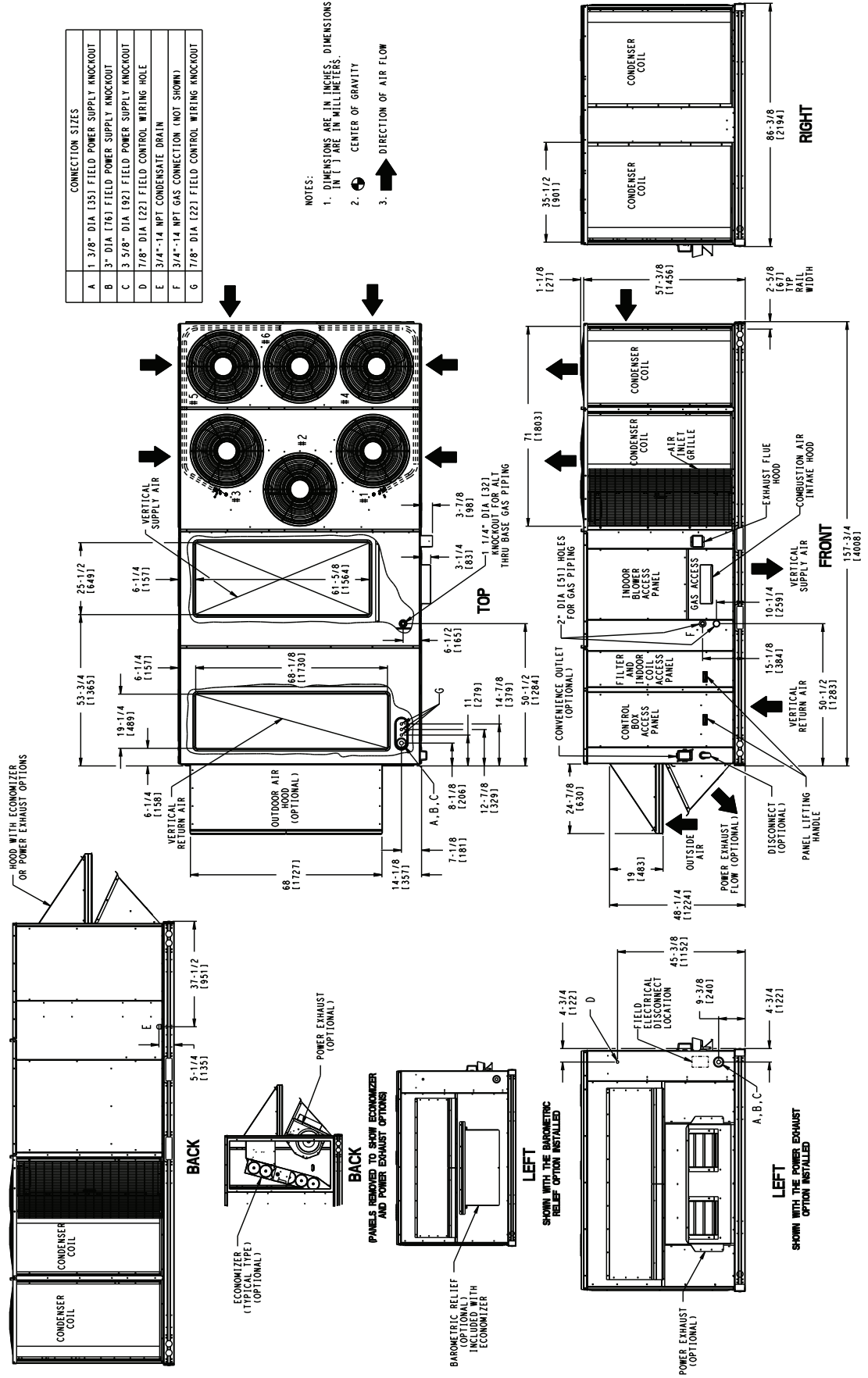

DIMENSIONS (CONT)

UNIT DIMENSIONAL DRAWING - RGS336 (cont)

UNIT	STD UNIT WEIGHT		CORNER WEIGHT (A)		CORNER WEIGHT (B)		CORNER WEIGHT (C)		CORNER WEIGHT (D)		C. G.			
	LBS.	KG.	LBS.	KG.	LBS.	KG.	LBS.	KG.	LBS.	KG.	X	Y	Z	
RGS336	2640	1200	697	317	595	270	621	282	728	331	44	1118	12 1/2 [1842]	19 [483]

* STANDARD UNIT WEIGHT IS WITH LOW GAS HEAT AND WITHOUT PACKAGING.
FOR OTHER OPTIONS AND ACCESSORIES, REFER TO THE PRODUCT DATA CATALOG.

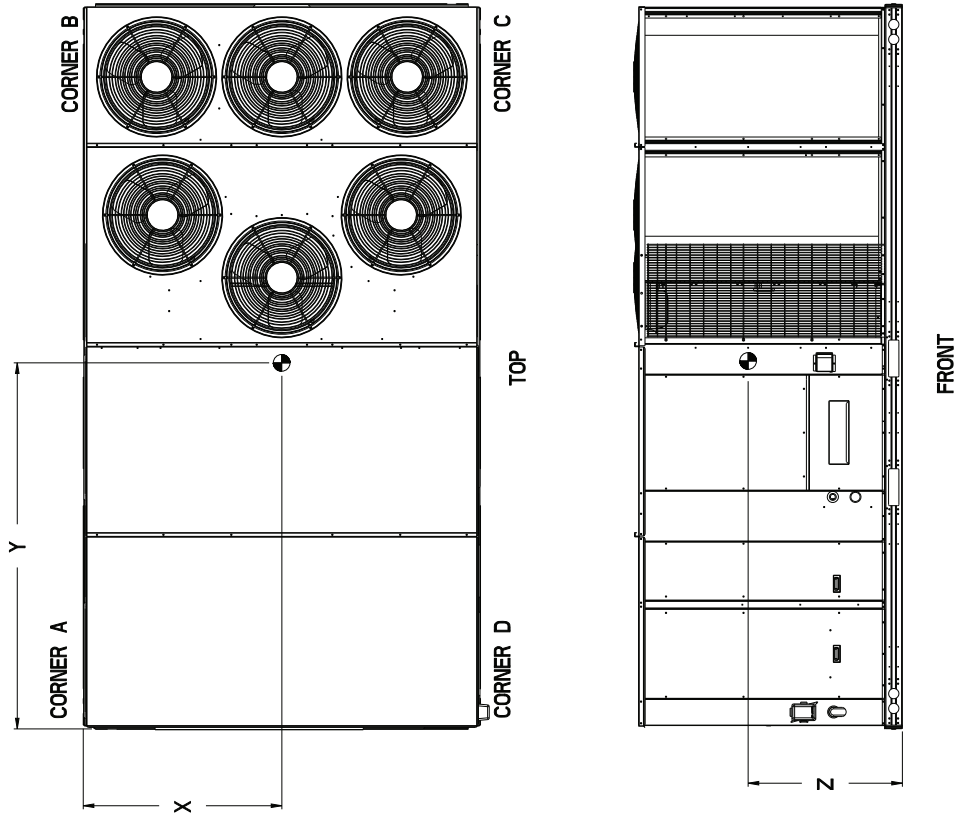

SERVICE CLEARANCE DIMENSIONAL DRAWING

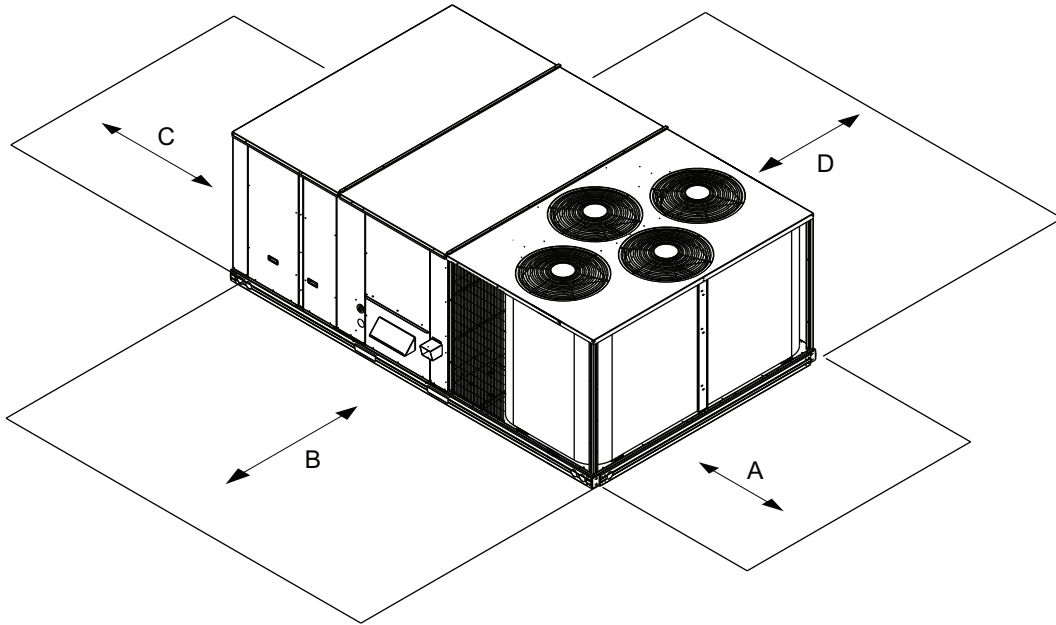

LOCATION	DIMENSION	CONDITION
A	36-in. (914 mm)	• Recommended clearance for air flow and service
B	42-in. (1067 mm)	• Recommended clearance for air flow and service
C	18-in. (457 mm)	• No Convenience Outlet • No Economizer • No field-installed disconnect on economizer hood side (Factory-installed disconnect installed).
	36-in. (914 mm)	• Convenience Outlet installed. • Vertical surface behind servicer is electrically non-conductive (e.g.: wood, fiberglass).
	42-in. (1067 mm)	• Convenience Outlet installed. • Vertical surface behind servicer is electrically conductive (e.g.: metal, masonry).
	96-in. (2438 mm)	• Economizer and/or Power Exhaust installed. • Check for sources of flue products with 10 feet (3 meters) of economizer fresh air intake.
D	42-in. (1067 mm)	• Recommended clearance for service.

NOTE: Unit not designed to have overhead obstruction. Contact Application Engineering for guidance on any application planning overhead obstruction or for vertical clearances.

OPERATING WEIGHTS

RGS	UNIT LB (KG)			
	210	240	300	336
Base Unit				
RTPF Coil	1922 (874)	2072 (942)	2197 (999)	2640 (1200)
Economizer	246 (112)	246 (112)	246 (112)	246 (112)
Powered Outlet	35 (16)	35 (16)	35 (16)	35 (16)
Hot Gas Reheat System	110 (50)	120 (54)	120 (54)	n/a
Curb				
14-in/356 mm	240 (109)	255 (116)	255 (116)	255 (116)
24-in/610 mm	340 (154)	355 (161)	355 (161)	355 (161)

DIMENSIONS (CONT)

ROOF CURB DETAILS - RGS210

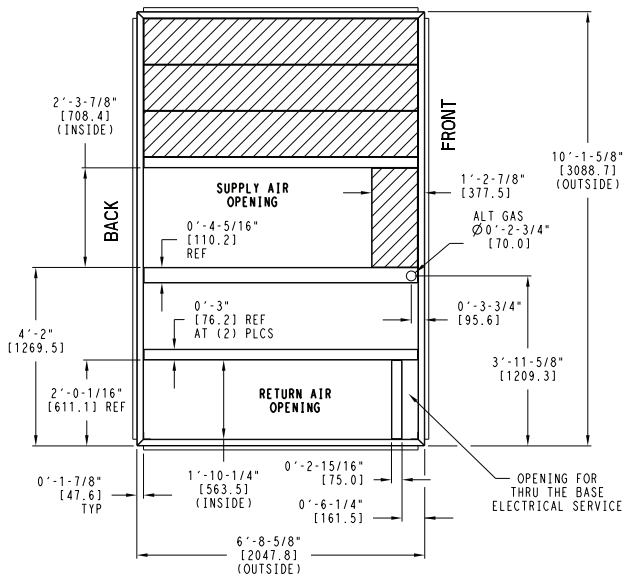

UNIT SIZE	"A"	ROOF CURB ACCESSORY
RGS210	1'-2" [356.0] 2'-0" [610.0]	CRRFCURB045A00 CRRFCURB046A00

- NOTES:
- 1 ROOF CURB ACCESSORY IS SHIPPED UNASSEMBLED.
 - 2 DIMENSIONS IN () ARE IN MILLIMETERS.
 - 3 ROOF CURB GALVANIZED STEEL.
 - 4 ATTACH DUCTWORK TO CURB (FLANGES ON DUCT REST ON CURB)
 - 5 SERVICE CLEARANCE 4 FT ON EACH SIDE

➔ DIRECTION OF AIR FLOW

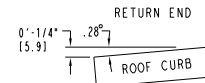
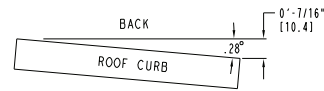

MAX CURB LEVELING TOLERANCES

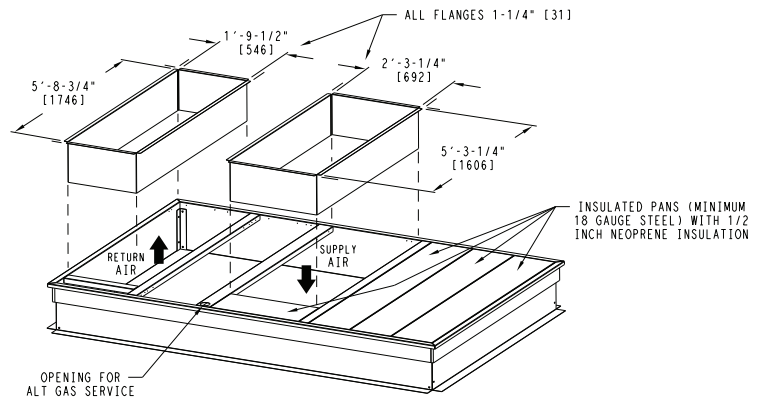
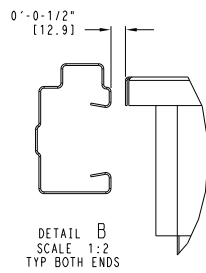
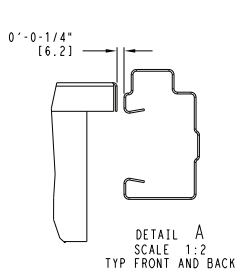
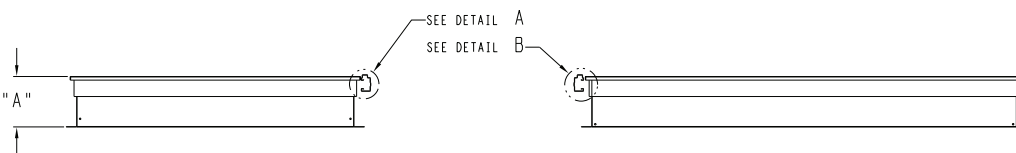
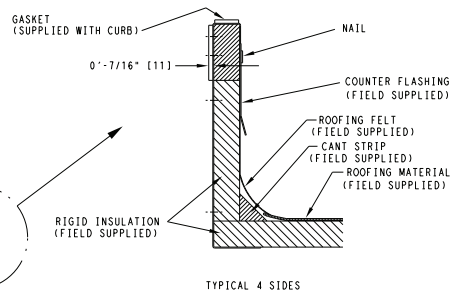
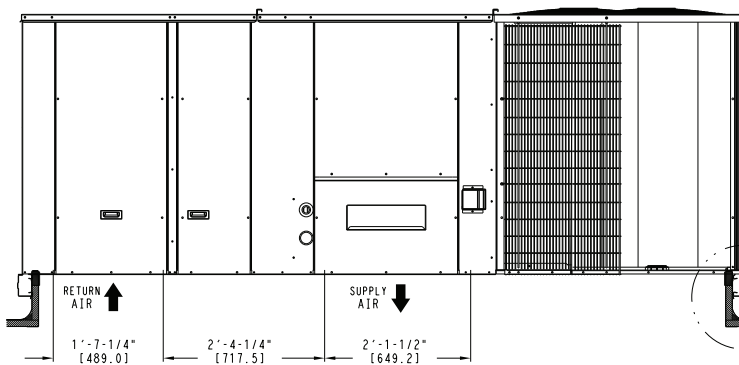

ROOF CURB DETAILS - RGS240 AND RGS300

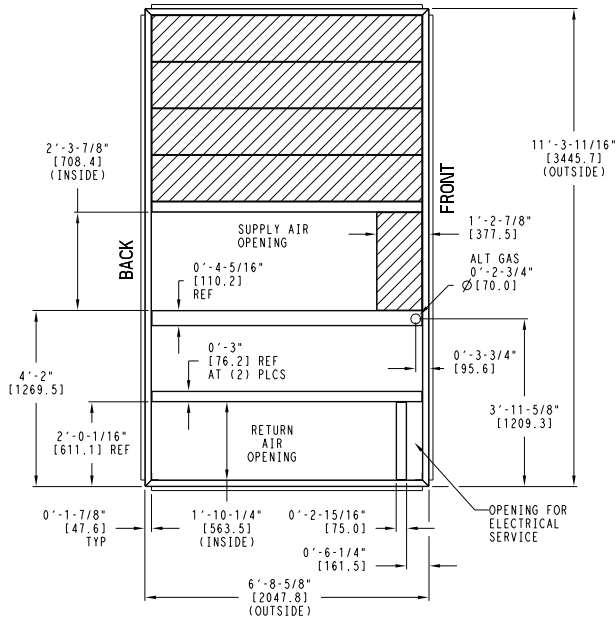

UNIT SIZE	"A"	ROOF CURB ACCESSORY
RGS240	1'-2" [356.0]	CRRFCURB047A00
RGS300	2'-0" [610.0]	CRRFCURB048A00

NOTES:

- 1 ROOF CURB ACCESSORY IS SHIPPED UNASSEMBLED.
- 2 DIMENSIONS IN [] ARE IN MILLIMETERS.
- 3 ROOF CURB GALVANIZED STEEL.
- 4 ATTACH DUCTWORK TO CURB (FLANGES ON DUCT REST ON CURB)
- 5 SERVICE CLEARANCE 4 FT ON EACH SIDE

➔ DIRECTION OF AIR FLOW

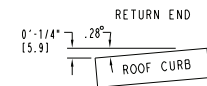
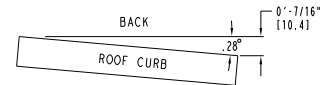

MAX CURB LEVELING TOLERANCES

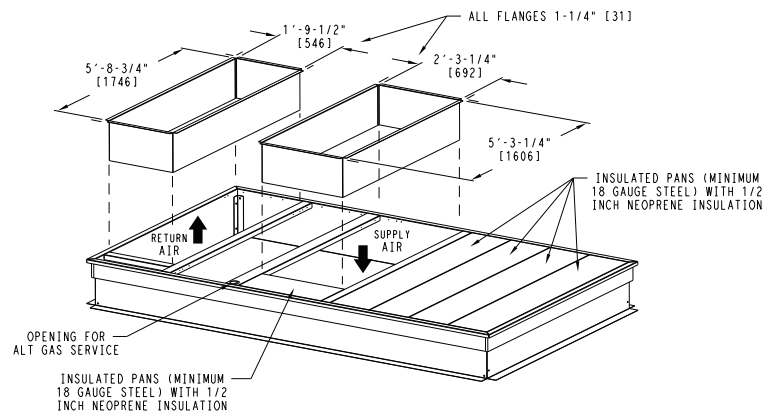
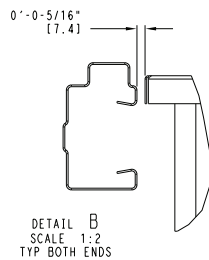
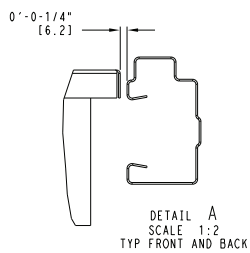
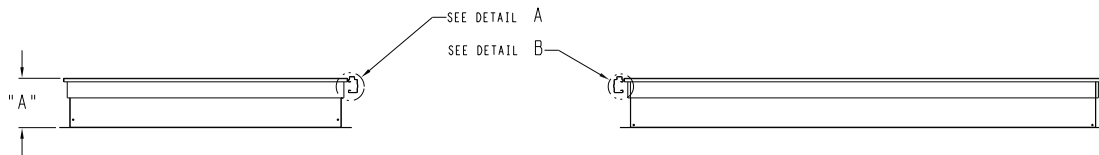
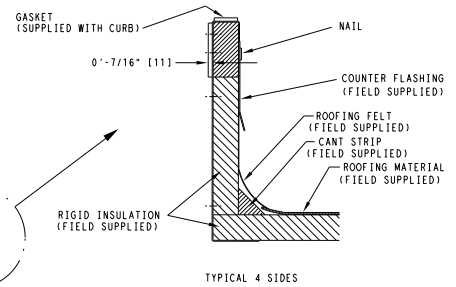
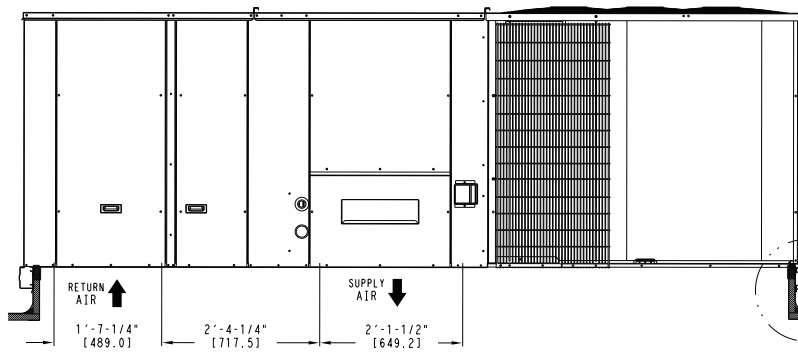

DIMENSIONS (CONT)

ROOF CURB DETAILS - RGS336

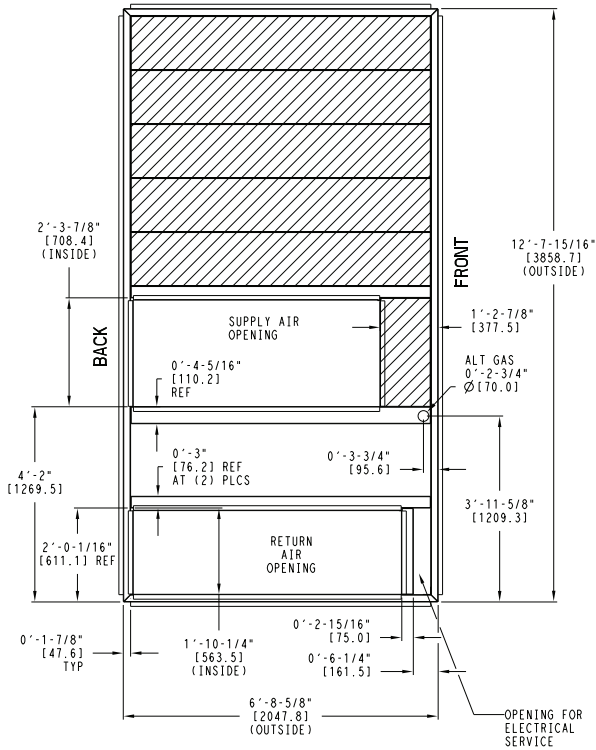

UNIT SIZE	"A"	ROOF CURB ACCESSORY
RGS336	1'-2" [356.0] 2'-0" [610.0]	CRRFCURB049A00 CRRFCURB050A00

- NOTES:
- 1 ROOF CURB ACCESSORY IS SHIPPED UNASSEMBLED.
 - 2 BOLT HEADS TO BE ON INSIDE OF FLANGE. CLEARANCE IS (1) 0-0-7/16" TYP ALL CORNERS.
 - 3 DIMENSIONS IN [] ARE IN MILLIMETERS.
 - 4 ROOF CURB GALVANIZED STEEL.
 - 5 ATTACH DUCTWORK TO CURB (FLANGES ON DUCT REST ON CURB)
 - 6 SERVICE CLEARANCE 4 FT ON EACH SIDE
 - 7 GAS SERVICE PLATE IS PART OF A SEPARATELY SHIPPED ACCESSORY PACKAGE.
 - 8 GAS SERVICE PLATE CAN BE USED WITH EITHER ACCESSORY ROOFCURB.

➔ DIRECTION OF AIR FLOW

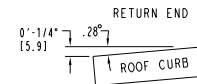
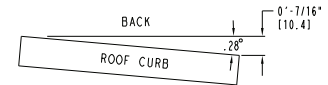

MAX CURB LEVELING TOLERANCES

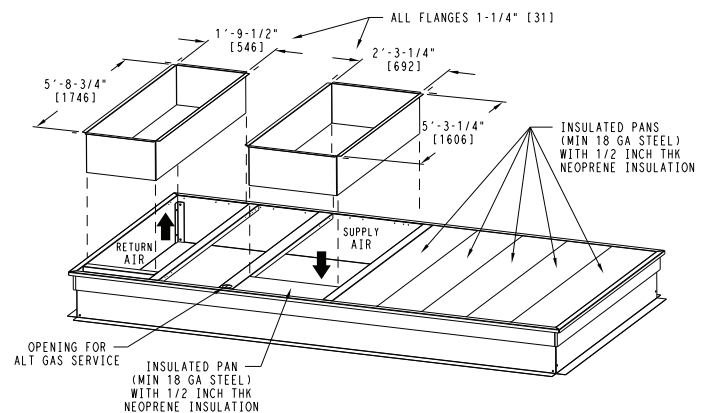
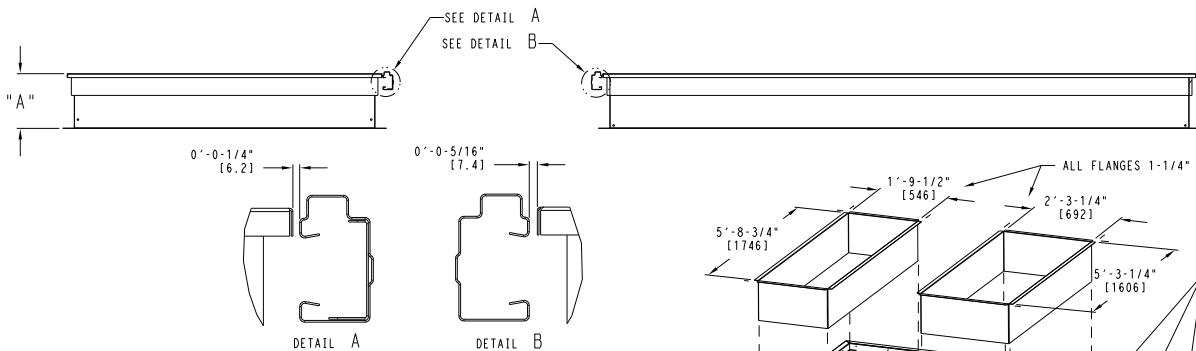
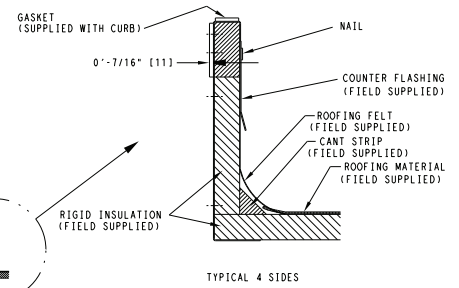
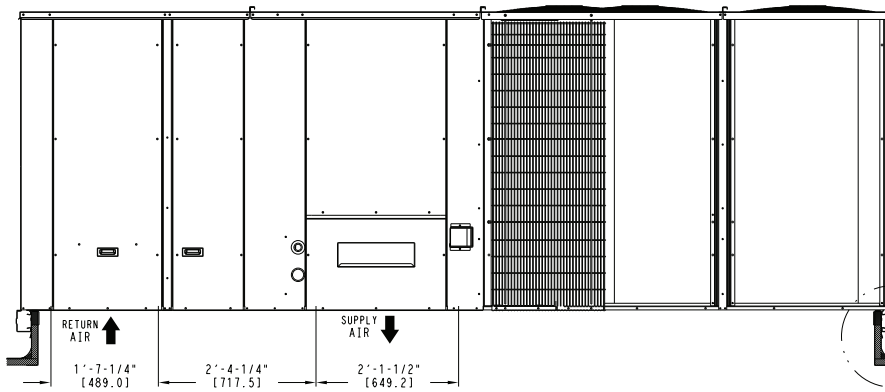

APPLICATION DATA

Min operating ambient temp (cooling)

In mechanical cooling mode, your rooftop unit can safely operate down to an outdoor ambient temperature of 30°F (-1°C). It is possible to provide cooling at lower outdoor ambient temperatures by using less outside air, economizers, and/or accessory low ambient kits.

Max operating ambient temp (cooling)

The maximum operating ambient temperature for cooling mode is 115°F (46°C). While cooling operation above 115°F (46°C) may be possible, it could cause either a reduction in performance, reliability, or a protective action by the unit's internal safety devices.

Min mixed air temp (heating)

Using the factory settings, the minimum temperatures for the mixed air (the combined temperature of the warm return air and the cold outdoor air) entering the dimpled, gas heat exchangers are:

Aluminized

50°F (10°C) continuous

45°F (7°C) intermittent

Stainless Steel

40°F (4°C) continuous

35°F (2°C) intermittent

Operating at lower mixed-air temperatures may be possible, if a field-supplied, outdoor air thermostat initiates both heat stages when the temperature is less than the minimum temperatures listed above. Please contact your local representative for assistance.

Min and max airflow (heating and cooling)

To maintain safe and reliable operation of your rooftop, operate within the heating airflow limits during heating mode and cooling airflow limits during cooling mode. Operating above the max may cause blow-off, undesired airflow noise, or airflow related problems with the rooftop unit. Operating below the min may cause problems with coil freeze-up and unsafe heating operation. For proper minimum and maximum CFM values see Minimum - Maximum Airflow Ratings - Natural Gas and Propane table on page 5.

Heating-to-cooling changeover

Your unit will automatically change from heating to cooling mode when using a thermostat with an auto-change-over feature.

Airflow

All units are draw-through in cooling mode and blow-through in heating mode.

Outdoor air application strategies

Economizers reduce operating expenses and compressor run time by providing a free source of cooling and a means of ventilation to match application changing needs. In fact, they should be considered for most applications. Also, consider the various economizer control methods and their benefits, as well as sensors required to accomplish your application goals.

Motor limits, break horsepower (BHP)

Due to internal design of units, the air path, and specially designed motors, the full horsepower (maximum continuous BHP) band, as listed in Physical Data Table Cooling, can be used with the utmost confidence. There is no need for extra safety factors, as motors are designed and rigorously tested to use the entire, listed BHP range without either nuisance tripping or premature motor failure.

Propane heating

Propane has different physical qualities than natural gas. As a result, Propane requires different fuel to air mixture. To optimize the fuel/air mixture for Propane, a kit with different burner orifices in an easy to install accessory kit. To select the correct burner orifices or determine the heat capacity for an Propane application, use either the selection software, or the unit's service manual.

High altitude heating

High altitudes have less oxygen, which affects the fuel/air mixture in heat exchangers. In order to maintain a proper fuel/air mixture, heat exchangers operating in altitudes above 2000 ft (610 m) require different orifices. To select the correct burner orifices or determine the heat capacity for a high altitude application, use either the selection software, or the unit's service manual.

High altitudes have less oxygen, which means heat exchangers need less fuel. The new gas orifices in this field-installed kit make the necessary adjustment for high altitude applications. They significantly improve fuel to air mixture and maintain healthy combustion on altitudes above 2000 ft (610 m).

NOTE: Typical natural gas heating value ranges from 975 to 1050 Btu/ft³ at sea level nationally. The heating value goes down approximately 1.7% per every thousand feet elevation. Standard factory orifices can typically be used up to 2000 ft (610 m) elevation without any operational issues.

Sizing a rooftop

Bigger isn't necessarily better. While an air conditioner needs to have enough capacity to meet the design loads, it doesn't need excess capacity. In fact, excess capacity typically results in very poor part load performance and humidity control.

Using higher design temperatures than ASHRAE recommends for your location, adding "safety factors" to the calculated load, are all signs of oversizing air conditioners. Oversizing the air conditioner leads to poor humidity control, reduced efficiency, higher utility bills, larger indoor temperature swings, excessive noise, and increased wear and tear on the air conditioner. Rather than oversizing an air conditioner, engineers should "right-size" or even slightly undersize air conditioners. Correctly sizing an air conditioner controls humidity better; promotes efficiency; reduces utility bills; extends equipment life, and maintains even, comfortable temperatures.

Low ambient applications

The optional economizer can adequately cool your space by bringing in fresh, cool outside air. In fact, when so equipped, accessory low-ambient kit may not be necessary. In low ambient conditions, unless the outdoor air is excessively humid or contaminated, economizer-based "free cooling" is the preferred less costly and energy conscious method. In low ambient applications where outside air might not be desired (such as contami-

APPLICATION DATA (CONT)

nated or excessively humid outdoor environments), your rooftop can operate to ambient temperatures down to -20°F (29°C) using the recommended accessory Motormaster low ambient controller.

Two-Speed Indoor Fan Motor System with variable frequency drive (VFD)

The 2-Speed Indoor Fan Motor system utilizes a Variable Frequency Drive (VFD) to automatically adjust the indoor fan motor speed in sequence with the units cooling operation. Per ASHRAE 90.1-2016 standard, during the first stage of cooling operation the VFD will adjust the fan motor to provide 66% of the total cfm established for the unit. When a call for the second stage of cooling is required, the VFD will allow the total cfm for the unit established (100%). During the heating mode, the VFD will allow total design cfm (100%) operation and during the ventilation mode the VFD will allow operation to 66% of total cfm.

The VFD used in the 2-Speed Indoor Fan Motor system has soft start capabilities to slowly ramp up the speeds, thus

eliminating any high inrush air volume during initial start-up. It also has internal over current protection for the fan motor and a field-installed display kit that allows adjustment and in depth diagnostics of the VFD.

This 2-Speed Indoor Fan Motor system is available on models with 2-stage cooling operation with electro-mechanical controls. Both space sensor and conventional thermostats controls can be used to provide accurate control in any application.

The 2-Speed Indoor Fan Motor system is very flexible for initial fan performance set up and adjustment. The standard factory shipped VFD is pre-programmed to automatically stage the fan speed between the first and second stage of cooling. The unit fan performance static pressure and cfm can be easily adjusted using the traditional means of pulley adjustments. The other means to adjust the unit static and cfm performance is to utilize the field-installed display module and adjust the frequency and voltage in the VFD to required performance requirements. In either case, once set up the VFD will automatically adjust the speed between the cooling stage operation.

STATIC PRESSURE ADDERS (in. wg)

HOT GAS REHEAT COIL

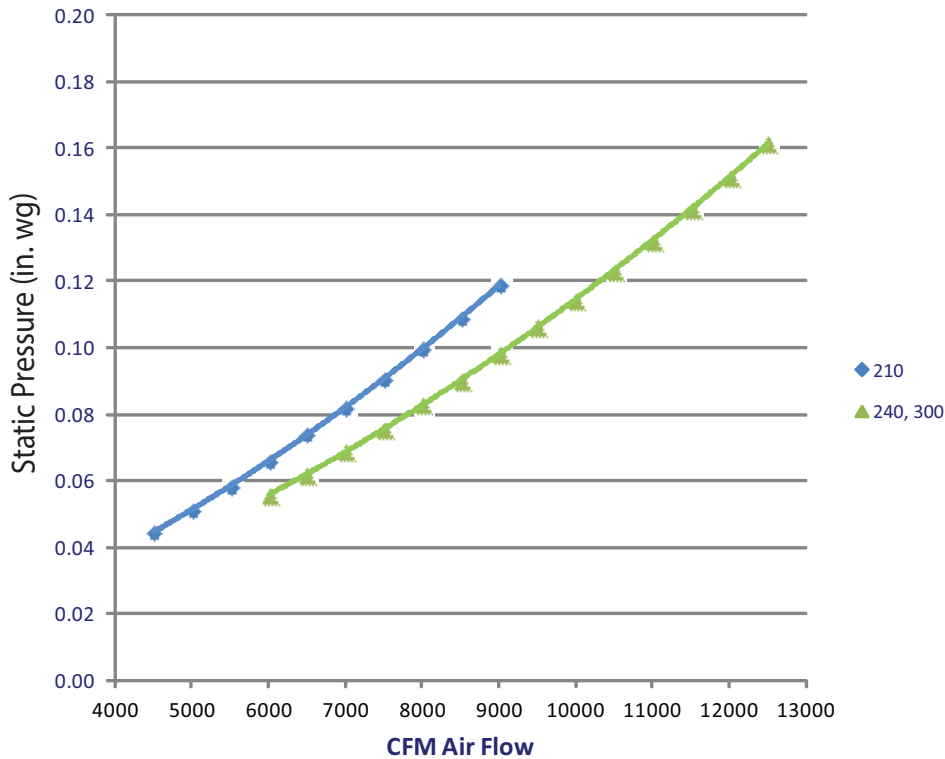

ECONOMIZER — VERTICAL DUCT CONFIGURATION

MODEL SIZES 210 - 336								
CFM	4,500	5,000	5,500	6,000	6,500	7,000	7,500	8,000
Static Pressure Adder (in. wg)	0.002	0.004	0.006	0.009	0.013	0.017	0.021	0.026

MODEL SIZES 210 - 336									
CFM	8,500	9,000	9,500	10,000	10,500	11,000	11,500	12,000	12,500
Static Pressure Adder (in. wg)	0.031	0.026	0.042	0.048	0.055	0.062	0.070	0.078	0.086

PERFORMANCE DATA

DAMPER, BAROMETRIC RELIEF AND PE PERFORMANCE MANUAL DAMPER PERFORMANCE

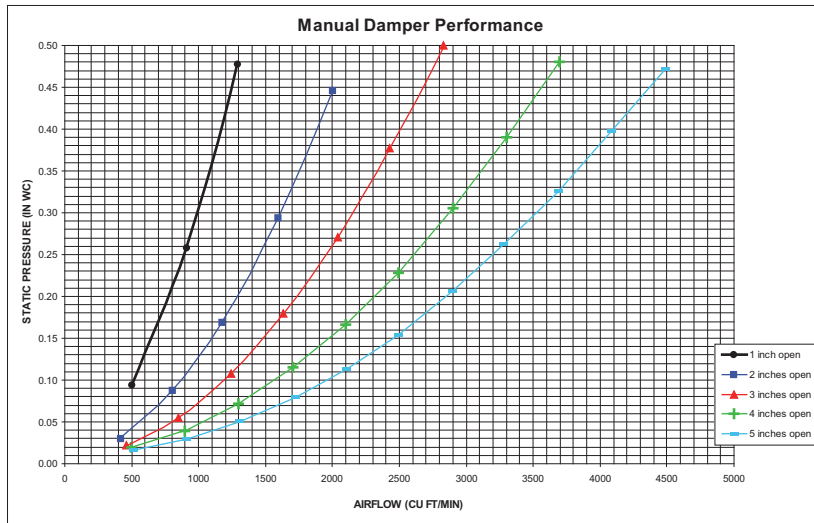

BAROMETRIC RELIEF FLOW CAPACITY

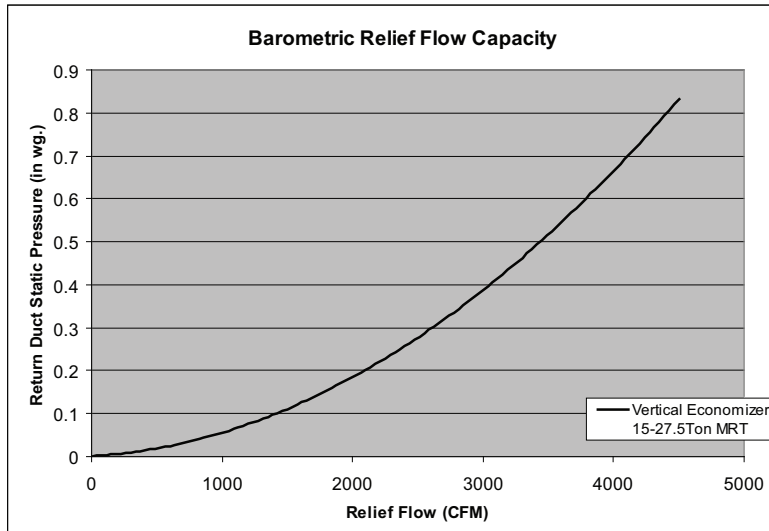

POWER EXHAUST FAN PERFORMANCE

Power Exhaust Fan Performance

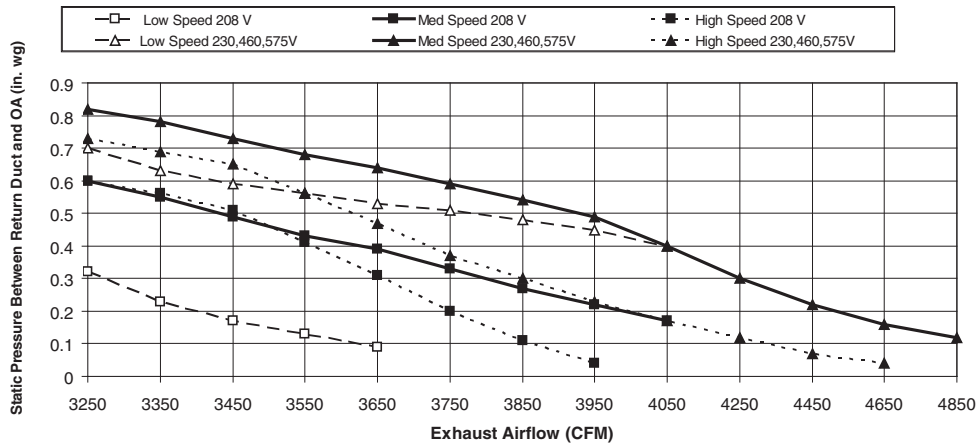

PERFORMANCE DATA (CONT)

GENERAL FAN PERFORMANCE NOTES

1. Interpolation is permissible. Do not extrapolate.
2. External static pressure is the static pressure difference between the return duct and the supply duct plus the static pressure caused by any factory-installed options (FIOPs) or accessories.
3. Tabular data accounts for pressure loss due to clean filters, high gas heat, unit casing, and wet coils. Factory options and accessories may add static pressure losses. Selection software is available, through your

salesperson, to help you select the best motor/drive combination for your application.

4. The Fan Performance tables offer motor/drive recommendations. In cases when two motor/drive combinations would work, the lower horsepower option is recommended.
5. For information on the electrical properties of motors, please see the Electrical information section of this book.
6. For more information on the performance limits of motors, see the application data section of this book.

RGS210 — 17.5 TON VERTICAL SUPPLY

CFM	Available External Static Pressure (in. wg)																			
	0.2		0.4		0.6		0.8		1.0		1.2		1.4		1.6		1.8		2.0	
	RPM	BHP	RPM	BHP	RPM	BHP	RPM	BHP	RPM	BHP	RPM	BHP	RPM	BHP	RPM	BHP	RPM	BHP	RPM	BHP
5250	547	1.10	626	1.45	700	1.84	766	2.24	828	2.67	885	3.11	939	3.57	990	4.05	1038	4.54	1084	5.04
5700	581	1.35	655	1.72	724	2.12	789	2.55	849	3.00	905	3.47	958	3.95	1008	4.45	1055	4.96	1100	5.48
6150	615	1.63	684	2.02	750	2.44	812	2.90	871	3.37	925	3.86	977	4.36	1026	4.88	1073	5.42	1118	5.96
6550	646	1.92	711	2.32	774	2.77	834	3.24	891	3.73	945	4.24	995	4.76	1043	5.30	1090	5.86	1134	6.42
7000	682	2.28	743	2.71	803	3.17	860	3.66	915	4.17	967	4.71	1017	5.26	1064	5.82	1109	6.39	1153	6.98
7450	718	2.70	775	3.14	832	3.62	887	4.13	940	4.67	991	5.22	1039	5.79	1085	6.38	1130	6.98	1172	7.59
7900	755	3.16	809	3.62	863	4.12	915	4.65	966	5.21	1015	5.78	1062	6.38	1107	6.99	1151	7.61	—	—
8300	787	3.62	839	4.09	891	4.61	941	5.16	990	5.73	1038	6.33	1084	6.94	1128	7.57	1171	8.21	—	—
8750	825	4.18	874	4.68	923	5.22	971	5.78	1018	6.38	1064	6.99	1109	7.63	1152	8.28	—	—	—	—

LEGEND

- STD Static - 622-822 RPM, 3.3 Max BHP
- MED Static - 713-879 RPM, Voltage 208V/230V/460V/575V, Max BHP 6.5/6.9/7.0/8.3
- HIGH Static - 882-1078 RPM, Voltage 208V/230V/460V/575V, Max BHP 6.5/6.9/7.0/8.3
- Requires high static drive package with different motor pulley. Confirm Max BHP based on unit voltage selected.
- BOLD** — Requires alternate standard static drive package
- Italics* — Requires high static drive package with different motor pulley. All voltages.
- Underscore — Operation point covered by factory package. Confirm Max BHP based on unit voltage selected.

RGS240 — 20 TON VERTICAL SUPPLY

CFM	Available External Static Pressure (in. wg)																			
	0.2		0.4		0.6		0.8		1.0		1.2		1.4		1.6		1.8		2.0	
	RPM	BHP	RPM	BHP	RPM	BHP	RPM	BHP	RPM	BHP	RPM	BHP	RPM	BHP	RPM	BHP	RPM	BHP	RPM	BHP
6,000	620	1.53	689	1.84	752	2.16	810	2.49	865	2.83	917	3.18	967	3.54	1015	3.91	1061	4.30	1105	4.69
6,500	660	1.88	725	2.22	785	2.56	841	2.92	894	3.28	944	3.65	992	4.03	1038	4.42	1083	4.82	1126	5.23
7,000	701	2.29	762	2.65	819	3.02	873	3.40	923	3.78	972	4.17	1018	4.57	1063	4.98	1106	5.40	1148	5.83
7,500	742	2.76	800	3.15	855	3.54	906	3.94	955	4.34	1001	4.76	1046	5.18	1090	5.61	1131	6.05	1172	6.49
8,000	784	3.30	839	3.71	891	4.12	940	4.55	987	4.97	1032	5.41	1076	5.85	1117	6.30	1158	6.76	—	—
8,500	826	3.90	879	4.33	928	4.78	975	5.22	1021	5.67	1064	6.13	1106	6.59	1147	7.07	1186	7.54	—	—
9,000	869	4.57	919	5.03	966	5.50	1011	5.97	1055	6.44	1097	6.92	1138	7.41	1177	7.90	—	—	—	—
9,500	911	5.32	959	5.81	1005	6.30	1048	6.79	1090	7.29	1131	7.79	1170	8.30	—	—	—	—	—	—
10,000	954	6.15	1000	6.66	1044	7.18	1086	7.70	1126	8.22	1166	8.75	—	—	—	—	—	—	—	—

LEGEND

- STD Static - 690-863 RPM, 4.9 Max BHP
- MED Static - 835-1021 RPM, Voltage 208V/230V/460V/575V, Max BHP 6.5/6.9/7.0/8.3
- HIGH Static - 941-1176 RPM, Voltage 208V/230V/460V/575V, Max BHP 10.5/11.9/11.9/11.0
- BOLD** — Requires alternate standard static drive package
- Italics* — Requires high static drive package with different motor pulley.

RGS300 — 25 TON VERTICAL SUPPLY

CFM	Available External Static Pressure (in. wg)																			
	0.2		0.4		0.6		0.8		1.0		1.2		1.4		1.6		1.8		2.0	
	RPM	BHP	RPM	BHP	RPM	BHP	RPM	BHP	RPM	BHP	RPM	BHP	RPM	BHP	RPM	BHP	RPM	BHP	RPM	BHP
7,500	731	2.21	796	2.60	856	3.00	911	3.40	963	3.81	1011	4.23	1058	4.66	1102	5.09	1145	5.53	1186	5.98
8,150	783	2.76	844	3.19	901	3.61	954	4.05	1003	4.49	1050	4.94	1095	5.39	1138	5.85	1180	6.32	—	—
8,750	832	3.35	890	3.80	943	4.26	994	4.73	1042	5.19	1088	5.67	1131	6.15	1173	6.64	—	—	—	—
9,400	885	4.08	940	4.57	991	5.06	1039	5.55	1085	6.05	1129	6.56	1171	7.07	—	—	—	—	—	—
10,000	934	4.85	986	5.36	1035	5.88	1082	6.40	1126	6.93	1169	7.47	—	—	—	—	—	—	—	—
10,650	988	5.78	1038	6.33	1084	6.88	1129	7.44	1172	8.00	—	—	—	—	—	—	—	—	—	—
11,250	1038	6.74	1086	7.32	1130	7.91	1173	8.49	—	—	—	—	—	—	—	—	—	—	—	—
11,900	1093	7.91	1138	8.52	1181	9.14	—	—	—	—	—	—	—	—	—	—	—	—	—	—
12,500	1144	9.10	1186	9.74	—	—	—	—	—	—	—	—	—	—	—	—	—	—	—	—

LEGEND

- STD Static - 717-911 RPM, 4.9 Max BHP
- MED Static - 913-1116 RPM, Voltage 208V/230V/460V/575V, Max BHP 6.5/6.9/7.0/8.3
- HIGH Static - 941-1176 RPM, Voltage 208V/230V/460V/575V, Max BHP 10.5/11.9/11.9/11.0
- BOLD** — Requires alternate standard static drive package
- Italics* — Requires high static drive package with different motor pulley.
- Underscore — Operation point covered by factory package. Confirm Max BHP based on unit voltage selected.

RGS336 — 27.5 TON VERTICAL SUPPLY

CFM	Available External Static Pressure (in. wg)																			
	0.2		0.4		0.6		0.8		1.0		1.2		1.4		1.6		1.8		2.0	
	RPM	BHP	RPM	BHP	RPM	BHP	RPM	BHP	RPM	BHP	RPM	BHP	RPM	BHP	RPM	BHP	RPM	BHP	RPM	BHP
8,250	791	2.86	852	3.28	908	3.72	960	4.16	1010	4.60	1056	5.05	1101	5.51	1144	5.98	1185	6.45	1225	6.93
8,950	848	3.57	905	4.03	958	4.50	1008	4.97	1055	5.45	1100	5.93	1144	6.42	1185	6.92	1225	7.42	1264	7.93
9,650	906	4.39	959	4.89	1009	5.39	1057	5.89	1102	6.41	1146	6.92	1187	7.45	1228	7.98	1266	8.51	—	—
10,300	959	5.26	1010	5.79	1058	6.33	1104	6.87	1147	7.41	1189	7.96	1229	8.51	1268	9.07	—	—	—	—
11,000	1018	6.33	1066	6.90	1111	7.47	1155	8.04	1197	8.62	1237	9.20	1276	9.79	—	—	—	—	—	—
11,700	1076	7.54	1122	8.14	1165	8.74	1207	9.35	1247	9.96	1286	10.58	—	—	—	—	—	—	—	—
12,400	1135	8.90	1178	9.53	1220	10.17	1260	10.82	1299	11.46	—	—	—	—	—	—	—	—	—	—
13,050	1190	10.30	1231	10.97	1271	11.64	—	—	—	—	—	—	—	—	—	—	—	—	—	—
13,750	1249	11.97	1289	12.67	—	—	—	—	—	—	—	—	—	—	—	—	—	—	—	—

LEGEND

- STD Static - 751-954 RPM, 6.5 Max BHP
- MED Static - 973-1175 RPM, Voltage 208V/230V/460V/575V, Max BHP 10.5/11.9/11.9/11.0
- HIGH Static - 1015-1300 RPM, Voltage 208V/230V/460V/575V, Max BHP 11.9/12.9/12.9/14.1
- Requires high static drive package with different motor pulley. Confirm Max BHP based on unit voltage selected.

PERFORMANCE DATA (CONT)

PULLEY ADJUSTMENT — VERTICAL

RGS UNIT	MOTOR/DRIVE COMBO	MOTOR PULLEY TURNS OPEN (RPM)										
		0	0.5	1	1.5	2	2.5	3	3.5	4	4.5	5
210	Standard Static	822	802	782	762	742	722	702	682	662	642	622
	Medium Static	879	862	846	829	813	796	779	763	746	730	713
	High Static	1078	1058	1039	1019	1000	980	960	941	921	902	882
240	Standard Static	863	846	828	811	794	777	759	742	725	707	690
	Medium Static	1021	1002	984	965	947	928	909	891	872	854	835
	High Static	1176	1153	1129	1106	1082	1059	1035	1012	988	965	941
300	Standard Static	911	892	872	853	833	814	795	775	756	736	717
	Medium Static	1116	1096	1075	1055	1035	1015	994	974	954	933	913
	High Static	1176	1153	1129	1106	1082	1059	1035	1012	988	965	941
336	Standard Static	954	934	913	893	873	853	832	812	792	771	751
	Medium Static	1175	1155	1135	1114	1094	1074	1054	1034	1013	993	973
	High Static	1299	1271	1242	1214	1185	1157	1129	1100	1072	1043	1015

NOTE: Do not adjust pulley further than 5 turns open.

■ — Factory settings

ELECTRICAL DATA

LEGEND AND NOTES

Applicable for Electrical Data Tables on pages 40-45

LEGEND	
BRKR	— Circuit breaker
C.O.	— Convenience outlet
DISC	— Disconnect
EFF	— Efficiency
FLA	— Full load amps
LRA	— Locked rotor amps
MCA	— Minimum circuit amps
P.E.	— Power exhaust
Pwrdr fr/unit	— Powered from unit
PWRD C.O.	— Powered convenience outlet
RLA	— Rated load amps
UNPWR C.O.	— Un-powered convenience outlet

NOTES

- In compliance with NEC requirements for multi-motor and combination load equipment (refer to NEC Articles 430 and 440), the overcurrent protective device for the unit shall be fuse or HACR breaker. Canadian units may be fuse or circuit breaker.
- For 208/230 v units, where one value is shown it is the same for either 208 or 230 volts.
- Unbalanced 3-Phase Supply Voltage
Never operate a motor where a phase imbalance in supply voltage is greater than 2%. Use the following formula to determine the percentage of voltage imbalance.

Example: Supply voltage is 230-3-60

$$\% \text{ Voltage Imbalance} = 100 \times \frac{\text{max voltage deviation from average voltage}}{\text{average voltage}}$$

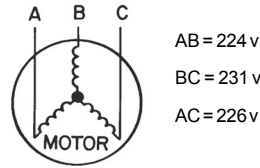

AB = 224 v
BC = 231 v
AC = 226 v

$$\text{Average Voltage} = \frac{(224 + 231 + 226)}{3} = \frac{631}{3} = 227$$

Determine maximum deviation from average voltage.

(AB) 227 - 224 = 3 v

(BC) 231 - 227 = 4 v

(AC) 227 - 226 = 1 v

Maximum deviation is 4 v.

Determine percent of voltage imbalance.

$$\% \text{ Voltage Imbalance} = 100 \times \frac{4}{227} = 1.76\%$$

This amount of phase imbalance is satisfactory as it is below the maximum allowable 2%.

IMPORTANT: If the supply voltage phase imbalance is more than 2%, contact your local electric utility company immediately.

NOTE: The 2-speed motors are the same efficiency level as the single speed motors.

ELECTRICAL DATA (CONT)

2-STAGE COOLING WITH SINGLE SPEED INDOOR FAN MOTOR, 17-27.5 TONS

RGS UNIT	V-Ph-Hz	VOLTAGE RANGE		COMP 1		COMP 2		OFM (ea)		IFM		
		Min	Max	RLA	LRA	RLA	LRA	Watts	FLA	Efficiency Type	Eff at Full Load	FLA
210	208-3-60	187	253	29.5	195	28.2	329	350	1.5	STD	87.0%	10.6
										MED-High Eff.	89.5%	17.1
										HIGH-High Eff.	89.5%	17.1
	230-3-60	187	253	29.5	195	28.2	164	350	1.5	STD	87.0%	10.6
										MED-High Eff.	89.5%	17.1
										HIGH-High Eff.	89.5%	17.1
	460-3-60	414	506	14.7	95	14.7	130	277	0.9	STD	87.0%	5.3
										MED-High Eff.	89.5%	8.6
										HIGH	89.5%	8.6
	575-3-60	518	633	12.2	80	11.3	94	397	0.6	STD	81.1%	2.8
										MED-High Eff.	83.6%	5.6
										HIGH-High Eff.	89.5%	7.6
240	208-3-60	187	253	48.2	245	29.5	329	350	1.5	STD	82.9%	13.6
										MED-High Eff.	89.5%	17.1
										HIGH-High Eff.	91.7%	28.5
	230-3-60	187	253	48.1	245	29.5	164	350	1.5	STD	82.9%	12.7
										MED-High Eff.	89.5%	17.1
										HIGH-High Eff.	91.7%	28.5
	460-3-60	414	506	18.6	125	14.7	130	277	0.9	STD	82.9%	6.4
										MED-High Eff.	89.5%	8.6
										HIGH-High Eff.	91.7%	14.3
	575-3-60	518	633	14.7	100	12.2	94	397	0.6	STD	83.6%	5.6
										MED-High Eff.	89.5%	7.6
										HIGH-High Eff.	91.7%	9.5
300	208-3-60	187	253	48.1	245	48.1	245	350	1.5	STD	82.9%	13.6
										MED-HIGH	89.5%	17.1
										HIGH-HIGH	91.7%	28.5
	230-3-60	187	253	48.1	245	48.1	245	350	1.5	STD	82.9%	12.7
										MED-HIGH	89.5%	17.1
										HIGH-HIGH	91.7%	28.5
	460-3-60	414	506	18.6	100	18.6	125	277	0.9	STD	82.9%	6.4
										MED-HIGH	89.5%	8.6
										HIGH-HIGH	91.7%	14.3
	575-3-60	518	633	14.7	300	14.7	100	397	0.6	STD	83.6%	5.6
										MED-HIGH	89.5%	7.6
										HIGH-HIGH	91.7%	9.5
336	208-3-60	187	253	51.3	300	51.3	300	350	1.5	STD	83.6%	13.6
										MED-HIGH	89.5%	17.1
										HIGH-HIGH	91.7%	28.5
	230-3-60	187	253	23.1	239	51.3	300	350	1.5	STD	89.5%	17.1
										MED-HIGH	91.7%	28.5
										HIGH-HIGH	91.7%	30.4
	460-3-60	414	506	14.7	150	23.1	150	277	0.9	STD	89.5%	8.6
										MED-HIGH	91.7%	14.3
										HIGH-HIGH	91.7%	15.2
	575-3-60	518	633	19.9	109	19.9	109	397	0.6	STD	89.5%	7.6
										MED-HIGH	91.7%	9.6
										HIGH-HIGH	91.7%	12.4

See: Legend and Notes on page 39.

2-STAGE COOLING WITH SINGLE 2-SPEED INDOOR FAN MOTOR, 17-27.5 TONS

RGS UNIT	V-Ph-Hz	VOLTAGE RANGE		COMP 1		COMP 2		OFM (ea)		IFM		
		Min	Max	RLA	LRA	RLA	LRA	Watts	FLA	Efficiency Type	Eff at Full Load	FLA
210	208-3-60	187	253	29.5	195	28.2	329	350	1.5	STD	87.0%	10.6
										MED	89.5%	17.1
										HIGH	89.5%	17.1
	230-3-60	187	253	29.5	195	28.2	164	350	1.5	STD	87.0%	10.6
										MED	89.5%	17.1
										HIGH	89.5%	17.1
	460-3-60	414	506	14.7	95	14.7	130	277	0.9	STD	87.0%	5.3
										MED	89.5%	8.6
										HIGH	89.5%	8.6
	575-3-60	518	633	12.2	80	11.3	94	397	0.6	STD	81.1%	2.8
										MED	83.6%	5.6
										HIGH	89.5%	7.6
240	208-3-60	187	253	48.1	245	29.5	195	350	1.5	STD	83.6%	13.6
										MED	89.5%	17.1
										HIGH	91.7%	28.5
	230-3-60	187	253	48.1	245	29.5	195	350	1.5	STD	83.6%	12.7
										MED	89.5%	17.1
										HIGH	91.7%	28.5
	460-3-60	414	506	18.6	125	14.7	95	277	0.9	STD	83.6%	6.4
										MED	89.5%	8.6
										HIGH	91.7%	14.3
	575-3-60	518	633	14.7	100	12.2	80	397	0.6	STD	83.6%	6.2
										MED	89.5%	7.6
										HIGH	91.7%	9.5
300	208-3-60	187	253	48.1	245	48.1	245	350	1.5	STD	83.6%	13.6
										MED	89.5%	17.1
										HIGH	91.7%	28.5
	230-3-60	187	253	48.1	245	48.1	245	350	1.5	STD	83.6%	12.7
										MED	89.5%	17.1
										HIGH	91.7%	28.5
	460-3-60	414	506	18.6	125	18.6	125	277	0.9	STD	83.6%	6.4
										MED	89.5%	8.6
										HIGH	91.7%	14.3
	575-3-60	518	633	14.7	100	14.7	100	397	0.6	STD	83.6%	6.2
										MED	89.5%	7.6
										HIGH	91.7%	9.5
336	208-3-60	187	253	51.3	300	51.3	300	350	1.5	STD	89.5%	17.1
										MED	91.7%	28.5
										HIGH	91.7%	30.4
	230-3-60	187	253	51.3	300	51.3	300	350	1.5	STD	89.5%	17.1
										MED	91.7%	28.5
										HIGH	91.7%	30.4
	460-3-60	414	506	23.1	150	23.1	150	277	0.9	STD	89.5%	8.6
										MED	91.7%	14.3
										HIGH	91.7%	15.2
	575-3-60	518	633	19.9	109	19.9	109	397	0.6	STD	89.5%	7.6
										MED	91.7%	9.5
										HIGH	91.7%	12.4

See Legend and Notes on page 39.

ELECTRICAL DATA (CONT)

UNIT WIRE/FUSE OR HACR BREAKER SIZING DATA - SINGLE-SPEED INDOOR FAN MOTOR

RGS UNIT	NOM. V-Ph-Hz	IFM Type	NO C.O. or UNPWR C.O.							
			No P.E.				w/ P.E. (pwrd fr/ unit)			
			MCA	Max Fuse or HACR Brkr	Disc. Size		MCA	Max Fuse or HACR Brkr	Disc. Size	
					FLA	LRA			FLA	LRA
210	208/230-3-60	STD	80.2	100	84	529	92.0	100	97	549
		MED	86.7	100	91	527	89.5	125	105	547
		HIGH-High Efficiency	86.7	100	91	527	98.5	125	105	547
	460-3-60	STD	41.1	50	43	274	47.3	60	50	286
		MED	44.4	50	47	273	50.6	60	54	285
		HIGH-High Efficiency	44.4	50	47	273	50.6	60	54	285
	575-3-60	STD	31.2	40	32	202	36.0	45	38	210
		MED	34.0	45	36	216	36.8	50	41	224
		HIGH-High Efficiency	36.0	45	38	214	40.8	50	43	222
240	208/230-3-60	STD	109.2/108.3	150/150	112/111	540	121.0/120.1	150/150	125/124	560
		MED-High Efficiency	112.7	150	116	536	124.5	150	129	556
		HIGH-High Efficiency	124.1	150	129	615	135.9	175	142	635
	460-3-60	STD	48.0	60	50	272	54.2	60	57	284
		MED-High Efficiency	50.2	60	52	270	56.4	70	59	282
		HIGH-High Efficiency	55.9	70	59	310	62.1	80	66	322
	575-3-60	STD	38.6	50	40	224	43.4	50	46	232
		MED-High Efficiency	40.6	50	42	222	45.4	60	48	230
		HIGH-High Efficiency	42.5	50	45	249	47.3	60	50	257
300	208/230-3-60	STD	127.8/126.9	175/175	133/132	590	139.6/138.7	175/175	147/146	610
		MED-High Efficiency	131.3	175	137	586	143.1	175	151	606
		HIGH-High Efficiency	142.7	175	150	665	154.5	200	164	685
	460-3-60	STD	51.9	60	54	302	58.1	70	61	314
		MED-High Efficiency	54.1	60	57	300	60.3	70	64	312
		HIGH-High Efficiency	59.8	70	63	340	66.0	80	70	352
	575-3-60	STD	41.1	50	43	244	45.9	60	49	252
		MED-High Efficiency	43.1	50	45	242	47.9	60	51	250
		HIGH-High Efficiency	45.0	50	47	269	49.8	60	53	277
336	208/230-3-60	STD	141.5	175	148	702	153.3	200	162	722
		MED-High Efficiency	152.9	200	161	781	164.7	200	175	801
		HIGH-High Efficiency	154.8	200	163	812	166.5	200	177	832
	460-3-60	STD	66.0	80	69	354	72.2	90	76	366
		MED-High Efficiency	71.1	90	76	394	77.9	100	83	406
		HIGH-High Efficiency	72.6	90	77	409	78.8	100	84	421
	575-3-60	STD	56.0	70	59	264	60.8	80	64	272
		MED-High Efficiency	57.9	70	61	291	62.7	80	66	299
		HIGH-High Efficiency	60.8	80	64	302	65.6	80	70	310

See Legend and Notes on page 39.

UNIT WIRE/FUSE OR HACR BREAKER SIZING DATA - SINGLE-SPEED INDOOR FAN MOTOR

RGS UNIT	NOM. V-Ph-Hz	IFM TYPE	w/ PWRD C.O.							
			No P.E.				w/ P.E. (pwrd fr/ unit)			
			MCA	Max Fuse or HACR Brkr	Disc. Size		MCA	Max Fuse or HACR Brkr	Disc. Size	
					FLA	LRA			FLA	LRA
210	208/230-3-60	STD	85.0	100	89	534	96.8	125	103	554
		MED	91.5	100	97	532	103.3	125	110	552
		HIGH-High Efficiency	91.5	100	697	532	103.3	125	110	552
	460-3-60	STD	43.3	50	46	276	49.5	60	53	288
		MED	46.6	60	49	275	52.8	60	56	287
		HIGH-High Efficiency	46.5	60	49	275	52.8	60	56	287
	575-3-60	STD	32.9	45	34	204	37.7	45	40	212
		MED	35.7	45	37	218	40.5	50	43	226
		HIGH-High Efficiency	37.7	45	40	216	42.5	50	45	224
240	208/230-3-60	STD	114.0/113.1	150/150	117/116	545	125.8/124.9	150/150	131/130	565
		MED-High Efficiency	117.5	150	121	541	129.3	175	135	561
		HIGH-High Efficiency	128.9	175	134	620	140.7	175	148	640
	460-3-60	STD	50.2	60	52	274	56.4	70	59	286
		MED-High Efficiency	52.4	60	55	272	58.6	70	62	284
		HIGH-High Efficiency	58.1	70	61	312	64.3	80	69	324
	575-3-60	STD	40.3	50	42	226	45.1	50	48	234
		MED-High Efficiency	42.3	50	44	224	47.1	60	50	232
		HIGH-High Efficiency	44.2	50	47	251	49.3	60	52	259
300	208/230-3-60	STD	132.3/131.7	175/175	139/138	595	144.4/143.5	175/175	152/151	615
		MED-High Efficiency	136.1	175	143	591	147.9	175	156	611
		HIGH-High Efficiency	147.5	175	156	670	159.3	200	169	690
	460-3-60	STD	54.1	60	57	304	60.3	70	64	316
		MED-High Efficiency	56.3	70	59	302	62.5	80	66	314
		HIGH-High Efficiency	62.0	80	66	342	68.2	80	73	354
	575-3-60	STD	42.8	50	45	246	47.8	60	50	254
		MED-High Efficiency	44.8	50	47	244	49.6	60	53	252
		HIGH-High Efficiency	46.7	60	49	271	51.5	60	55	279
336	208/230-3-60	STD	146.3	175	154	707	158.1	200	167	727
		MED-High Efficiency	157.7	200	167	786	169.5	200	180	806
		HIGH-High Efficiency	159.6	200	169	817	171.4	200	182	837
	460-3-60	STD	68.2	90	72	356	74.4	90	79	368
		MED-High Efficiency	73.9	90	78	396	80.1	100	85	408
		HIGH-High Efficiency	74.8	90	79	411	81.0	100	86	423
	575-3-60	STD	57.7	70	61	266	62.5	80	66	274
		MED-High Efficiency	59.6	70	63	293	64.4	80	68	301
		HIGH-High Efficiency	62.5	80	66	304	67.3	80	72	312

See Legend and Notes on page 39.

ELECTRICAL DATA (CONT)

UNIT WIRE/FUSE OR HACR BREAKER SIZING DATA WITH FACTORY-INSTALLED 2-SPEED INDOOR FAN OPTION

RGS UNIT	NOM. V-Ph-Hz	IFM TYPE	NO C.O. or UNPWR C.O.							
			No P.E.				w/ P.E. (pwrd fr/ unit)			
			MCA	Max Fuse or HACR Brkr	Disc. Size		MCA	Max Fuse or HACR Brkr	Disc. Size	
					FLA	LRA			FLA	LRA
210	208/230-3-60	STD	80.4/79.4	100/100	84/83	520	92.2/91.2	100/100	96/96	540
		MED	83.2/82.3	100/100	87/86	531	95.0/94.1	110/110	101/100	551
		HIGH	86.7	100	91	527	98.5	125	105	547
	460-3-60	STD	40.4	50	43	270	46.9	60	50	282
		MED	42.2	50	44	275	48.4	60	51	287
		HIGH	44.4	50	47	273	50.6	60	54	285
	575-3-60	STD	32.9	45	34	202	37.7	45	40	210
		MED	34.6	45	36	216	39.4	50	42	224
		HIGH	36.0	45	38	214	40.8	50	43	222
240	208/230-3-60	STD	109.2/108.3	150/150	112/111	540	121.0/120.1	150/150	125/124	560
		MED	112.7	150	116	536	124.5	150	129	556
		HIGH	124.1	150	129	615	135.9	175	142	63.5
	460-3-60	STD	48.0	60	50	272	54.2	60	57	284
		MED	50.2	60	52	270	56.4	70	59	282
		HIGH	55.9	70	59	310	62.1	80	66	322
	575-3-60	STD	39.2	50	41	224	44.0	50	46	232
		MED	40.8	50	42	222	45.4	60	48	230
		HIGH	42.5	50	45	249	47.3	60	50	257
300	208/230-3-60	STD	127.8/126.9	175/175	133/132	590	139.6/138.7	175/8175	147/146	610
		MED	131.3	175	137	586	143.1	175	151	606
		HIGH	142.7	175	150	665	154.5	200	164	685
	460-3-60	STD	51.9	60	54	302	58.1	70	61	314
		MED	54.1	60	57	300	60.3	70	64	312
		HIGH	59.8	70	63	340	66.0	80	70	352
	575-3-60	STD	41.7	50	44	244	46.5	60	49	252
		MED	43.1	50	45	242	47.9	60	51	250
		HIGH	45.0	50	47	269	49.8	60	53	277
336	208/230-3-60	STD	141.50	175	148	702	153.3	200	162	722
		MED	152.9	200	161	781	164.7	200	175	801
		HIGH	154.8	200	163	812	166.6	200	177	832
	460-3-60	STD	66.0	80	69	354	72.2	90	76	366
		MED	71.7	90	76	394	77.9	100	83	406
		HIGH	72.6	90	77	409	78.8	100	84	421
	575-3-60	STD	56.0	70	59	264	60.8	80	64	272
		MED	57.9	70	61	291	62.7	80	66	1299
		HIGH	60.8	80	64	302	66.5	80	70	310

See Legend and Notes on page 39.

**UNIT WIRE/FUSE OR HACR BREAKER SIZING DATA
WITH FACTORY-INSTALLED 2-SPEED INDOOR FAN OPTION (cont)**

RGS UNIT	NOM. V-Ph-Hz	IFM TYPE	w/ PWRD C.O.							
			No P.E.				w/ P.E. (pwrd fr/ unit)			
			MCA	Max Fuse or HACR Brkr	Disc. Size		MCA	Max Fuse or HACR Brkr	Disc. Size	
					FLA	LRA			FLA	LRA
210	208/230-3-60	STD	85.2/84.2	100/100	89/88	525	97.0/96.0	125/125	103/102	545
		MED	88.0/87.1	100/100	93/92	536	99.8/98.9	125/125	106/105	556
		HIGH	91.5	100	97	532	103.3	125	110	552
	460-3-60	STD	42.9	50	45	272	49.1	60	52	284
		MED	44.4	50	47	277	50.6	60	54	589
		HIGH	46.6	60	49	275	52.8	60	56	287
	575-3-60	STD	34.6	45	36	204	39.4	50	42	212
		MED	36.3	45	38	218	41.1	50	44	226
		HIGH	37.7	45	40	216	42.5	50	45	224
240	208/230-3-60	STD	114.0/113.1	150/150	117/116	545	125.8/124.9	105/150	131/130	565
		MED	117.5	150	121	541	129.3	175	135	561
		HIGH	128.9	175	134	620	140.7	175	148	640
	460-3-60	STD	50.2	60	52	274	56.4	70	59	286
		MED	52.4	60	55	272	58.6	70	62	284
		HIGH	58.1	70	61	312	64.3	80	69	324
	575-3-60	STD	40.9	50	43	226	45.7	60	48	234
		MED	42.3	50	44	224	47.1	60	50	232
		HIGH	44.2	50	47	251	49.0	60	52	259
300	208/230-3-60	STD	132.6/131.7	175/175	139/138	595	144.4/143.5	175/175	152/151	615
		MED	136.1	175	143	591	147.9	175	156	611
		HIGH	147.5	175	156	670	159.3	200	169	690
	460-3-60	STD	54.1	60	57	304	60.3	70	64	316
		MED	56.3	70	59	302	62.5	80	66	314
		HIGH	62.0	80	66	342	68.2	80	73	354
	575-3-60	STD	43.4	50	46	246	48.2	60	51	254
		MED	44.8	50	47	244	49.6	60	53	252
		HIGH	46.7	60	49	271	51.5	60	55	279
336	208/230-3-60	STD	146.3	175	154	707	158.1	200	167	727
		MED	157.7	200	167	786	169.5	200	180	806
		HIGH	159.6	200	169	817	171.4	200	182	837
	460-3-60	STD	68.2	90	72	358	74.4	90	79	368
		MED	73.9	90	78	396	80.1	100	85	408
		HIGH	74.8	90	79	411	81.0	100	86	423
	575-3-60	STD	57.7	70	61	266	62.5	80	66	274
		MED	59.6	70	63	293	64.4	80	68	301
		HIGH	62.5	80	66	304	67.3	80	72	312

See Legend and Notes on page 39.

TYPICAL WIRING DIAGRAMS

TYPICAL POWER WIRING DIAGRAM

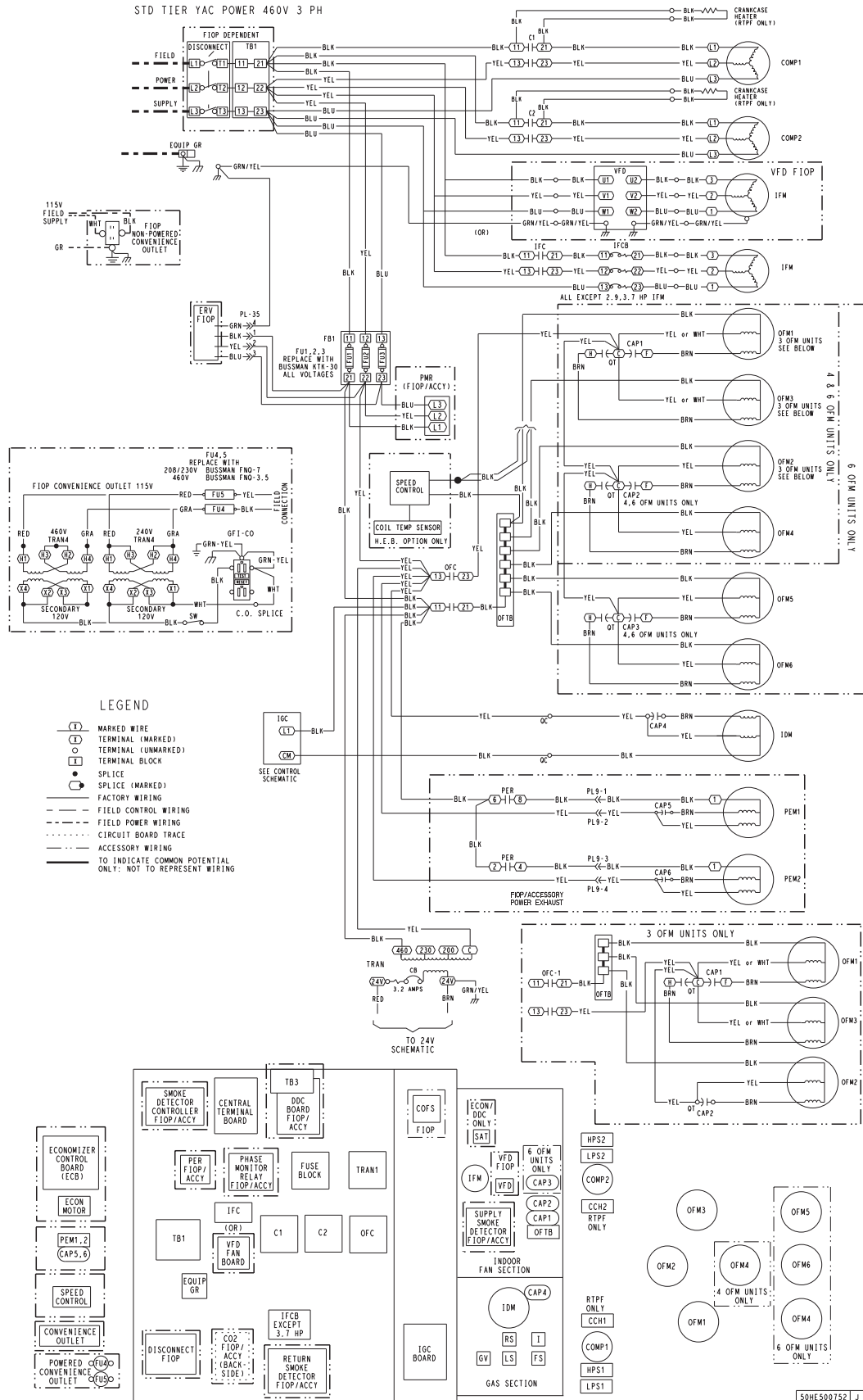

ELECTRO-MECHANICAL CONTROL WIRING DIAGRAM

STD TIER YAC CONTROL 208/230V, 460V, 575V

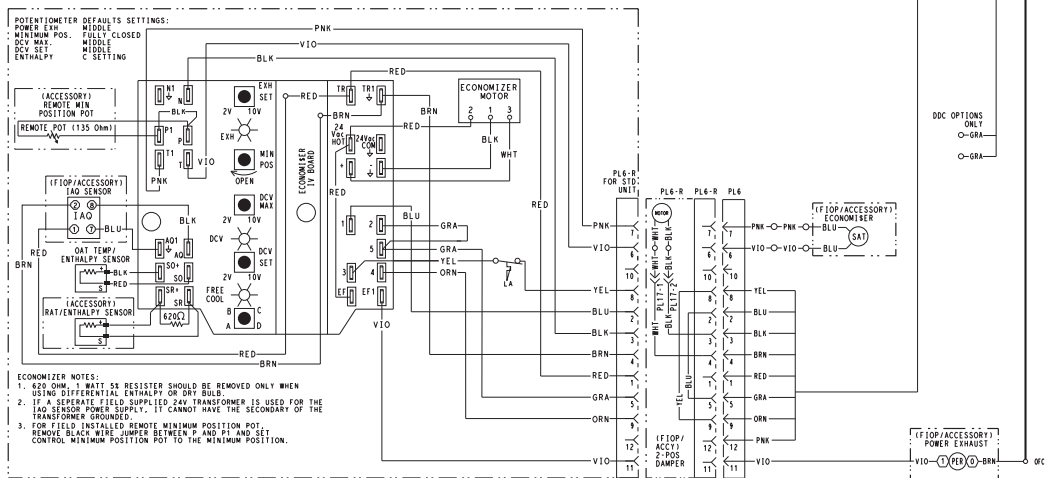
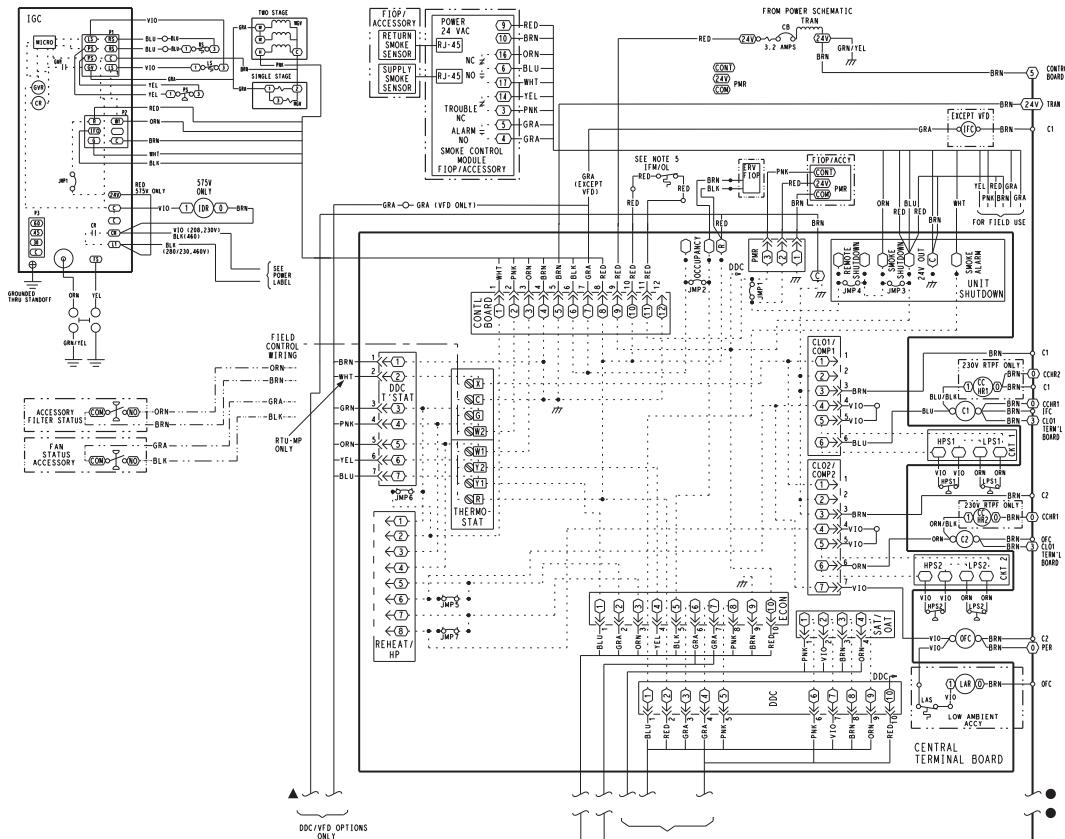

ECONOMIZER NOTES:

1. 450 OHM 1/2 WATT 5% RESISTOR SHOULD BE REMOVED ONLY WHEN USING DIFFERENTIAL ENTHALPY OR DRY BULB.
2. IF SEPARATE FIELD SUPPLIED 24V TRANSFORMER IS USED FOR THE IAO SENSOR POWER SUPPLY, IT CANNOT HAVE THE SECONDARY OF THE TRANSFORMER GROUND.
3. FOR FIELD INSTALLED REMOTE MINIMUM POSITION POT: REMOVE BLK WIRE JUMPER BETWEEN P AND P1 AND SET CONTROL MINIMUM POSITION POT TO THE MINIMUM POSITION.

- NOTES:**
1. IF ANY OF THE ORIGINAL WIRE FURNISHED MUST BE REPLACED, IT MUST BE REPLACED WITH TYPE 90 C WIRE OR ITS EQUIVALENT.
 2. COMPRESSOR AND FAN MOTORS ARE THERMALLY PROTECTED. THREE PHASE MOTORS ARE PROTECTED AGAINST PRIMARY SINGLE PHASING CONDITIONS.
 3. 208/230V UNIT TRAN IS WIRED FOR 230V UNIT. IF UNIT IS TO BE RUN WITH 208V POWER SUPPLY, DISCONNECT BLK WIRE FROM 230V TAP AND CONNECT TO 200V TAP.
 4. USE COPPER CONDUCTOR ONLY.
 5. IFM OL IS NOT USED ON ALL MODELS. WHEN NOT USED, RED LEADS ARE CONNECTED TOGETHER.

C	CONTACTOR, COMPRESSOR	IFM	INDOOR FAN MOTOR	PL6-R	PL6-R FOR STD. UNIT	PL6	(F10P/ACCESSORY) ECONOMISER
CAP	CAPACITOR	IGC	INDOOR GAS CONTROL	PL6-R	PL6-R FOR STD. UNIT	PL6	(F10P/ACCESSORY) ECONOMISER
CB	CIRCUIT BREAKER	IRH	INDOOR RELATIVE HUMIDITY	PL6-R	PL6-R FOR STD. UNIT	PL6	(F10P/ACCESSORY) ECONOMISER
CCH	CRANKCASE HEATER	LA	LOW AMBIENT LOCKOUT	PL6-R	PL6-R FOR STD. UNIT	PL6	(F10P/ACCESSORY) ECONOMISER
CCNR	CRANKCASE HEATER RELAY	LAR	LOW AMBIENT RELAY	PL6-R	PL6-R FOR STD. UNIT	PL6	(F10P/ACCESSORY) ECONOMISER
CCN	CARRIER COMFORT NETWORK	LAS	LOW AMBIENT SWITCH	PL6-R	PL6-R FOR STD. UNIT	PL6	(F10P/ACCESSORY) ECONOMISER
CMP SAFE	COMPRESSOR SAFETY	LOOP PWR	LOW PRESSURE SWITCH	PL6-R	PL6-R FOR STD. UNIT	PL6	(F10P/ACCESSORY) ECONOMISER
COFS	CONDENSATE OVERTFLOW SWITCH	LSM	LIMIT SWITCH (MANUAL RESET)	PL6-R	PL6-R FOR STD. UNIT	PL6	(F10P/ACCESSORY) ECONOMISER
COMP	COMPRESSOR MOTOR	MOV	MAIN GAS VALVE	PL6-R	PL6-R FOR STD. UNIT	PL6	(F10P/ACCESSORY) ECONOMISER
CTB	CENTRAL TERMINAL BOARD	OAO	OUTDOOR AIR QUALITY	PL6-R	PL6-R FOR STD. UNIT	PL6	(F10P/ACCESSORY) ECONOMISER
DDC	DIRECT DIGITAL CONTROL	OAT	OUTDOOR AIR TEMP. SEN	PL6-R	PL6-R FOR STD. UNIT	PL6	(F10P/ACCESSORY) ECONOMISER
ERV	ENERGY RECOVERY VENTILATOR	OTC	OUTDOOR FAN CONTACTOR	PL6-R	PL6-R FOR STD. UNIT	PL6	(F10P/ACCESSORY) ECONOMISER
F10P	FACTORY INSTALLED OPTION	OTFB	OUTDOOR FAN TERMINAL BLOCK	PL6-R	PL6-R FOR STD. UNIT	PL6	(F10P/ACCESSORY) ECONOMISER
FSD	FIRE SHUT DOWN	OLF	OVERLOAD RELAY	PL6-R	PL6-R FOR STD. UNIT	PL6	(F10P/ACCESSORY) ECONOMISER
FU	FUSE	OLR	OVERLOAD RELAY	PL6-R	PL6-R FOR STD. UNIT	PL6	(F10P/ACCESSORY) ECONOMISER
GND	GROUND	PER	POWER EXHAUST RELAY	PL6-R	PL6-R FOR STD. UNIT	PL6	(F10P/ACCESSORY) ECONOMISER
GVR	GAS VALVE RELAY	PL	PLUG ASSEMBLY	PL6-R	PL6-R FOR STD. UNIT	PL6	(F10P/ACCESSORY) ECONOMISER
HPS	HIGH PRESSURE SWITCH	POT	POTENTIOMETER	PL6-R	PL6-R FOR STD. UNIT	PL6	(F10P/ACCESSORY) ECONOMISER
HS	HALL EFFECT SENSOR			PL6-R	PL6-R FOR STD. UNIT	PL6	(F10P/ACCESSORY) ECONOMISER
I	IGNITOR			PL6-R	PL6-R FOR STD. UNIT	PL6	(F10P/ACCESSORY) ECONOMISER
IAO	INDOOR AIR QUALITY SENSORS			PL6-R	PL6-R FOR STD. UNIT	PL6	(F10P/ACCESSORY) ECONOMISER
IDM	INDUCED DRAFT MOTOR			PL6-R	PL6-R FOR STD. UNIT	PL6	(F10P/ACCESSORY) ECONOMISER
IDR	INDUCED DRAFT RELAY			PL6-R	PL6-R FOR STD. UNIT	PL6	(F10P/ACCESSORY) ECONOMISER

CONTROLS

Sequence of Operation

The sequence below describes the sequence of operation for an electro-mechanical unit with and without a factory-installed EconoMiSer® IV and X (called “economizer” in this sequence). For information regarding a direct digital controller, see the start-up, operations, and troubleshooting manual for the applicable controller.

Electro-mechanical units with no economizer-cooling (Single speed indoor fan motor) —

When the thermostat calls for cooling, terminals G and Y1 are energized. As a result, the indoor-fan contactor (IFC) and the compressor contactor (C1) are energized, causing the indoor-air motor (IFM), compressor #1, and outdoor fan to start. If the unit has 2 stages of cooling, the thermostat will additionally energize Y2. The Y2 signal will energize compressor contactor #2 (C2), causing compressor #2 to start. Regardless of the number of stages, the outdoor-fan motor runs continuously while unit is cooling.

Cooling (2-speed indoor fan motor) — Per ASHRAE 90.1-2016, and IECC-2015 standards, during the first stage of cooling operation the VFD will adjust the fan motor to provide 66% of the total cfm established for the unit. When a call for the second stage of cooling is required, the VFD will allow the total cfm for the unit established (100%). This is standard on all models installed in the U.S. to meet U.S. Department of Energy - 2018 IEER efficiency rating.

Heating — Units have 2 stages of gas heat. When the thermostat calls for heating, power is sent to W on the Integrated Gas Controller (IGC) board. An LED (light-emitting diode) on the IGC board turns on and remains on during normal operation. A check is made to ensure that the roll-out switch and limit switch are closed. If the check was successful, the induced-draft motor is energized, and when its speed is satisfactory, as proven by the flue gas pressure switch, the ignition activation period begins. The burners will ignite within 5 seconds. If the burners do not light, there is a 22-second delay before another 5-second attempt. This sequence is repeated for 15 minutes or until the burners light. If, after the 15 minutes, the burners still have not lit, heating is locked out. To reset the control, break 24-v power to the thermostat.

When ignition occurs, the IGC board will continue to monitor the condition of the roll-out switch, the limit switches, the flue gas pressure switch, as well as the flame sensor. Forty-five seconds after ignition occurs, assuming the unit is controlled through a room thermostat set for fan auto, the indoor-fan motor will energize (and the outdoor-air dampers will open to their minimum position). If, for some reason, the over-temperature limit opens prior to the start of the indoor fan blower, the unit will shorten the 45-second delay to 5 seconds less than the time from initiation of heat to when the limit tripped. Gas will not be interrupted to the burners and heating will continue. Once the fan-on delay has been modified, it will not change back to 45 seconds until power is reset to the control. On units with 2 stages of heat, when additional heat is required, W2 closes and initiates power to the second stage of the main gas valve. When the thermostat is satisfied, W1 and W2 open and the gas valve closes, interrupting the flow of gas to the main burners.

If the call for W1 lasted less than 1 minute, the heating cycle will not terminate until 1 minute after W1 became active. If the unit is controlled through a room thermostat set for fan auto, the indoor-fan motor will continue to operate for an additional 45 seconds then stop. If the over-temperature limit opens after the indoor motor is stopped, but within 10 minutes of W1 becoming inactive, on the next cycle the time will be extended by 15 seconds. The maximum delay is 3 minutes. Once modified, the fan off delay will not change back to 45 seconds unless power is reset to the control. A LED indicator is provided on the IGC to monitor operation.

Electro-mechanical units with an economizer-cooling —

When free cooling is not available, the compressors will be controlled by the zone thermostat. When free cooling is available, the outdoor-air damper is modulated by the EconoMiSer IV and X control to provide a 50°F (10°C) to 55°F (13°C) mixed-air temperature into the zone. As the mixed air temperature fluctuates above 55°F (13°C) or below 50°F (10°C) dampers will be modulated (open or close) to bring the mixed-air temperature back within control. If mechanical cooling is utilized with free cooling, the outdoor-air damper will maintain its current position at the time the compressor is started. If the increase in cooling capacity causes the mixed-air temperature to drop below 45°F (7°C), then the outdoor-air damper position will be decreased to the minimum position. If the mixed-air temperature continues to fall, the outdoor-air damper will close. Control returns to normal once the mixed-air temperature rises above 48°F (9°C). The power exhaust fans will be energized and de-energized, if installed, as the outdoor-air damper opens and closes.

If field-installed accessory CO₂ sensors are connected to the EconoMiSer IV and X control, a demand controlled ventilation strategy will begin to operate. As the CO₂ level in the zone increases above the CO₂ setpoint, the minimum position of the damper will be increased proportionally. As the CO₂ level decreases because of the increase in fresh air, the outdoor-air damper will be proportionally closed. For EconoMiSer IV and X operation, there must be a thermostat call for the fan (G). If the unit is occupied and the fan is on, the damper will operate at minimum position. Otherwise, the damper will be closed.

When the EconoMiSer IV and X control is in the occupied mode and a call for cooling exists (Y1 on the thermostat), the control will first check for indoor fan operation. If the fan is not on, then cooling will not be activated. If the fan is on, then the control will open the EconoMiSer IV and damper to the minimum position.

On the initial power to the EconoMiSer IV and X control, it will take the damper up to 2 1/2 minutes before it begins to position itself. After the initial power-up, further changes in damper position can take up to 30 seconds to initiate. Damper movement from full closed to full open (or vice versa) will take between 1 1/2 and 2 1/2 minutes. If free cooling can be used as determined from the appropriate changeover command (switch, dry bulb, enthalpy curve, differential dry bulb, or differential enthalpy), then the control will modulate the dampers open to maintain the mixed-air temperature setpoint at 50°F (10°C) to 55°F (13°C).

If there is a further demand for cooling, then cooling second stage - Y2 is energized, and then the control will bring on compressor stage 1 to maintain the mixed-air temperature setpoint. The EconoMiSer® IV and X damper will be open at maximum

CONTROLS (CONT)

position. EconoMiSer IV and X operation is limited to a single compressor.

2-Speed Note: When operating in ventilation mode only, the indoor fan motor will automatically adjust to 66% of the total cfm established.

Heating — The sequence of operation for the heating is the same as an electro-mechanical unit with no economizer. The only difference is how the economizer acts. The economizer will stay at the Economizer Minimum Position while the evaporator fan is operating. The outdoor-air damper is closed when the indoor fan is not operating. Refer to Service and Maintenance Manual for further details.

Hot Gas Reheat

Units with the factory equipped Hot Gas Reheat option are capable of providing multiple modes of improved dehumidification as a variation of the normal cooling cycle. The Hot Gas

Reheat option includes additional valves in the liquid line and discharge line of each refrigerant circuit, a small reheat condenser coil downstream of the evaporator, and Motormaster variable-speed control of some or all outdoor fans. Operation of the revised refrigerant circuit for each mode is described below.

Hot Gas Reheat provides three sub-modes of operation: Cool, Reheat1, and Reheat2.

- Cool mode - provides a normal ratio of Sensible and Latent Cooling effect from the evaporator coil.
- Reheat1 - provides increased Latent Cooling while slightly reducing the Sensible Cooling effect.
- Reheat2 - provides normal Latent Cooling but with null or minimum Sensible Cooling effect delivered to the space.

The Reheat1 and Reheat2 modes are a variable when the unit is not in a Heating mode and when the Low Ambient Lockout switch is closed.

NORMAL COOLING MODE — HOT GAS REHEAT

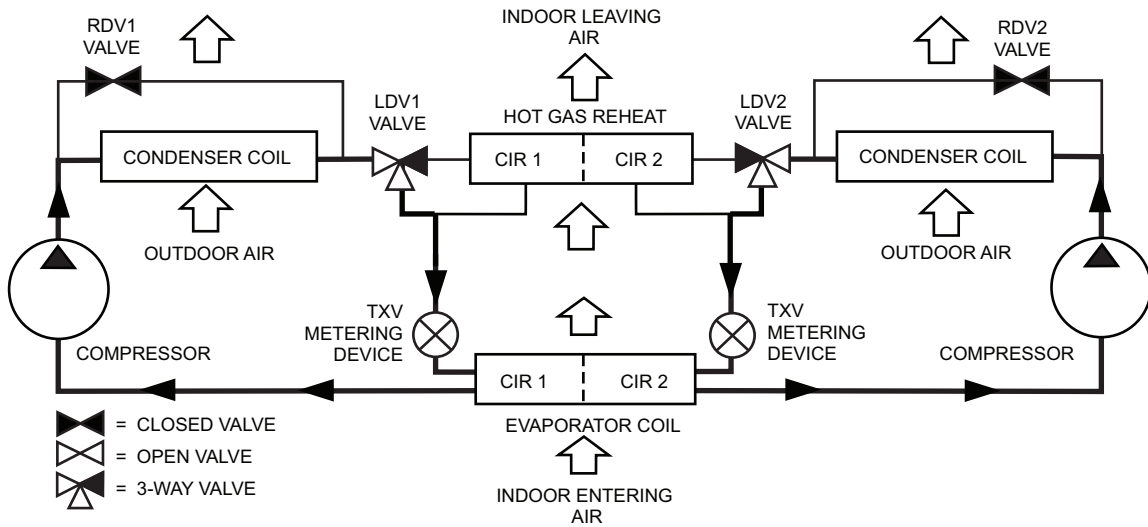

SUBCOOLING MODE (REHEAT 1) — HOT GAS REHEAT

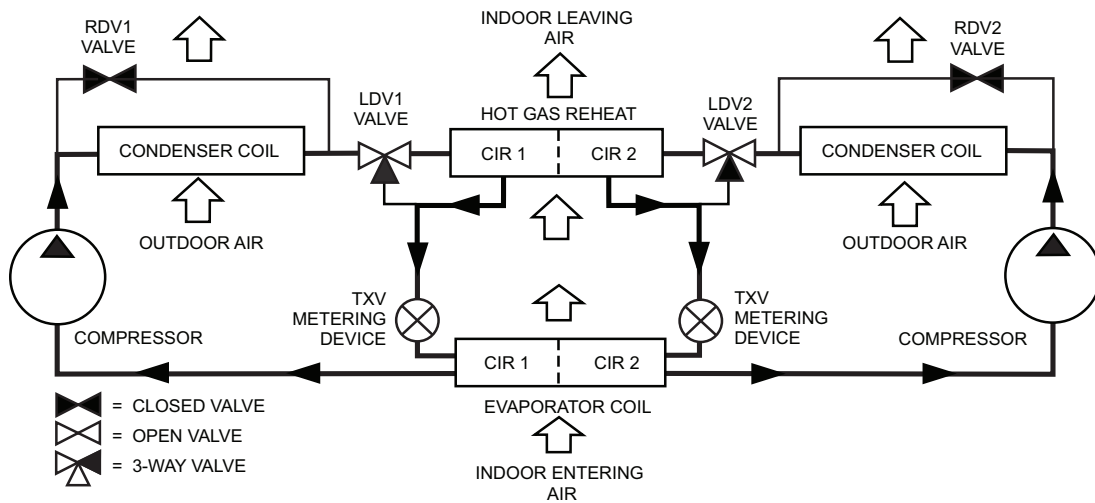

SUBCOOLING MODE (REHEAT 2) — HOT GAS REHEAT

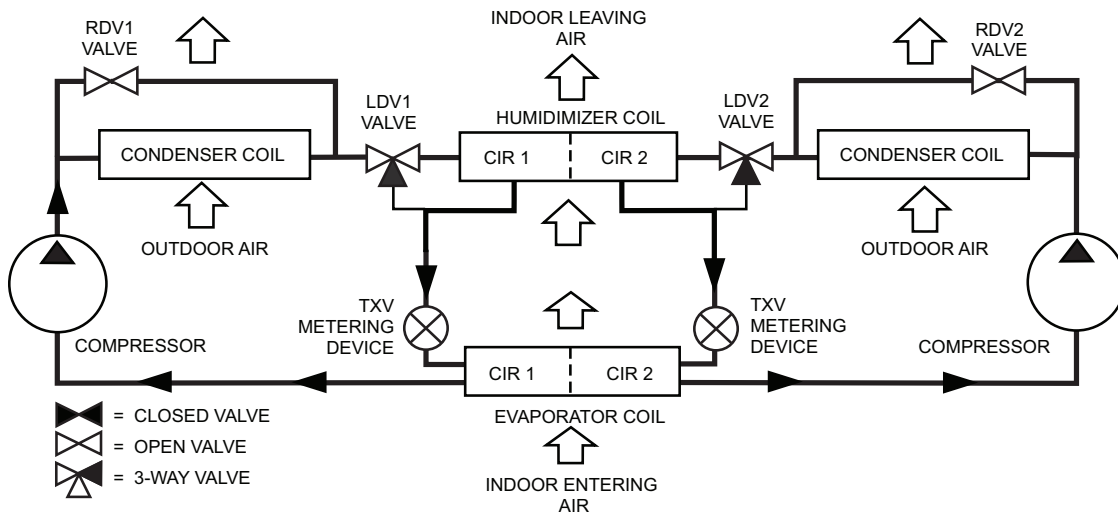

GUIDE SPECIFICATIONS — RGS210-336

Note about this specification: These specifications are written in "Masterformat" as published by the Construction Specification Institute. Please feel free to copy this specification directly into your building spec.

Gas heat/electric cooling packaged rooftop HVAC guide specifications

Size range: 17.5, 20, 25, 27.5 Nominal Tons

ICP Model Number: RGS

Part 1 — (23 06 80) Schedules for decentralized HVAC equipment

1.01 (23 06 80.13) Decentralized Unitary HVAC Equipment Schedule

- A. (23 06 80.13.A) Rooftop unit schedule
 - 1. Schedule is per the project specification requirements.

Part 2 — (23 07 16) HVAC equipment insulation

2.01 (23 07 16.13) Decentralized, Rooftop Units:

- A. (23 07 16.13.A.) Evaporator fan compartment:
 - 1. Interior cabinet surfaces shall be insulated with a minimum 1/2-in. thick, minimum 1 1/2-lb density, flexible fiberglass insulation bonded with a phenolic binder, neoprene coated on the air side.
 - 2. Insulation and adhesive shall meet NFPA 90A requirements for flame spread and smoke generation.
 - 3. Unit internal insulation linings shall be resistant to mold growth in accordance with "mold growth and humidity" test in ASTM C1338, G21, and UL 181 or comparable test method. Air stream surfaces shall be evaluated in accordance with the "Erosion Test" in UL 181, as part of ASTM C1071.
- B. (23 07 16.13.B.) Gas heat compartment:
 - 1. Aluminum foil-faced fiberglass insulation shall be used.
 - 2. Insulation and adhesive shall meet NFPA 90A requirements for flame spread and smoke generation.

Part 3 — (23 09 23) Instrumentation and control devices for HVAC

3.01 (23 09 12.13) Sensors and Transmitters

- A. (23 09 12.13.A.) Thermostats:
 - 1. Thermostat must
 - a. energize both "W" and "G" when calling for heat.
 - b. have capability to energize 2 different stages of cooling, and 2 different stages of heating.
 - c. include capability for occupancy scheduling.

Part 4 — (23 09 23) Direct-digital control system for HVAC

4.01 (23 09 33.13) Decentralized, rooftop units

- A. (23 09 33.13.A.) General:
 - 1. Shall be complete with self-contained low-voltage control circuit protected by a resettable

circuit breaker on the 24-v transformer side. Transformer shall have 75VA capability.

- 2. Shall utilize color-coded wiring.
 - 3. Shall include a central control terminal board to conveniently and safely provide connection points for vital control functions such as: smoke detectors, phase monitor, gas controller, economizer, thermostat, DDC control options, and low and high pressure switches.
 - 4. The heat exchanger shall be controlled by an integrated gas controller (IGC) microprocessor. See heat exchanger section of this specification.
 - 5. Unit shall include a minimum of one 8-pin screw terminal connection board for connection of control wiring.
- B. (23 09 33.13.B.) Safeties:
 - 1. Compressor over-temperature, over-current. High internal pressure differential.
 - 2. Low-pressure switch.
 - a. Units shall have different sized connectors for the circuit 1 and circuit 2 low and high pressure switches. They shall physically prevent the cross-wiring of the safety switches between circuits 1 and 2.
 - b. Low-pressure switch shall use different color wire than the high-pressure switch. The purpose is to assist the installer and service technician to correctly wire and/or troubleshoot the rooftop unit.
 - 3. High-pressure switch.
 - a. Units shall have different sized connectors for the circuit 1 and circuit 2 low and high-pressure switches. They shall physically prevent the cross-wiring of the safety switches between circuits 1 and 2.
 - b. High-pressure switch shall use different color wire than the low-pressure switch. The purpose is to assist the installer and service technician to correctly wire and or troubleshoot the rooftop unit.
 - 4. Automatic reset, motor thermal overload protector.
 - 5. Heating section shall be provided with the following minimum protections:
 - a. High-temperature limit switches.
 - b. Induced draft motor speed sensor.
 - c. Flame roll-out switch.
 - d. Flame proving controls.

Part 5 — (23 09 93) Sequence of operations for HVAC controls

5.01 (23 09 93 13) Decentralized, Rooftop Units:

- A. (23 09 93 13.A.) INSERT SEQUENCE OF OPERATION

Part 6 — (23 40 13) Panel air filters

6.01 (23 40 13.13) Decentralized rooftop units:

- A. (23 40.13.13.A.) Standard filter section:
1. Shall consist of factory-installed, low velocity, disposable 2-in. thick fiberglass filters of commercially available sizes.
 2. Unit shall use only one filter size. Multiple sizes are not acceptable.
 3. Filters shall be accessible through a dedicated, weather tight access panel.
 4. 4-in. filter capabilities shall be capable with pre-engineered and approved filter track field-installed accessory. This kit requires field furnished filters.

Part 7 — (23 81 19) Self-contained air conditioners

7.01 (23 81 19.13) Medium-Capacity Self-Contained Air Conditioners (RGS210-336)

- A. (23 81 19.13.A.) General:
1. Outdoor, rooftop mounted, electrically controlled, heating and cooling unit utilizing a fully hermetic scroll compressor(s) for cooling duty and gas combustion for heating duty.
 2. Factory assembled, single-piece heating and cooling rooftop unit. Contained within the unit enclosure shall be all factory wiring, piping, controls, and special features required prior to field start-up.
 3. Unit shall use R-410A refrigerant.
 4. Unit shall be installed in accordance with the manufacturer's instructions.
 5. Unit must be selected and installed in compliance with local, state, and federal codes.
- B. (23 81 19.13.B.) Quality Assurance
1. Unit meets Department of Energy-2018, ASHRAE 90.1-2016 and IECC-2015 minimum efficiency requirements.
 2. Unit shall be rated in accordance with AHRI Standard 340/360.
 3. Unit shall be designed to conform to ASHRAE 15.
 4. Unit shall be ETL-tested and certified in accordance with ANSI Z21.47 Standards and ETL-listed and certified under Canadian standards as a total package for safety requirements.
 5. Insulation and adhesive shall meet NFPA 90A requirements for flame spread and smoke generation.
 6. Unit internal insulation linings shall be resistant to mold growth in accordance with "mold growth and humidity" test in ASTM C1338, G21, and UL 181 or comparable test method. Air stream surfaces shall be evaluated in accordance with the "Erosion Test" in UL 181, as part of ASTM C1071.

7. Unit casing shall be capable of withstanding 500-hour salt spray exposure per ASTM B117 (scribed specimen).
 8. Roof curb shall be designed to conform to NRCA Standards.
 9. Unit shall be subjected to a completely automated run test on the assembly line. The data for each unit will be stored at the factory, and must be available upon request.
 10. Unit shall be designed in accordance with UL Standard 1995, ETL listed including tested to withstand rain.
 11. Unit shall be constructed to prevent intrusion of snow and tested to prevent snow intrusion into the control box up to 40 mph.
 12. Unit shake tested to assurance level 1, ASTM D4169 to ensure shipping reliability.
 13. High Efficiency Motors listed shall meet section 313 of the Energy Independence and Security Act of 2007 (EISA 2007).
- C. (23 81 19.13.C.) Delivery, storage, and handling:
1. Unit shall be stored and handled per manufacturer's recommendations.
 2. Lifted by crane requires either shipping top panel or spreader bars.
 3. Unit shall only be stored or positioned in the upright position.
- D. (23 81 19.13.D.) Project conditions:
1. As specified in the contract.
- E. (23 81 19.13.E.) Operating characteristics:
1. Unit shall be capable of starting and running at 115°F (46°C) ambient outdoor temperature, meeting maximum load criteria of AHRI Standard 340/360 at ± 10% voltage.
 2. Compressor with standard controls shall be capable of operation down to 30°F (-1°C), ambient outdoor temperatures. Accessory winter start kit is necessary if mechanically cooling at ambient temperatures below 30°F (-1°C).
 3. Unit shall discharge supply air vertically as shown on contract drawings.
 4. Unit shall be factory configured and ordered for vertical supply and return configurations.
 5. Unit shall be factory furnished for vertical configuration. No field conversion is required.
- F. (23 81 19.13.F.) Electrical Requirements:
1. Main power supply voltage, phase, and frequency must match those required by the manufacturer.

GUIDE SPECIFICATIONS — RGS210-336 (CONT)

G. (23 81 19.13.G.) Unit cabinet:

1. Unit cabinet shall be constructed of galvanized steel, and shall be bonderized and coated with a pre-painted baked enamel finish on all externally exposed surfaces.
2. Unit cabinet exterior paint shall be: film thickness, (dry) 0.003 inches minimum, gloss (per ASTM D523, 60°F / 16°C): 60, Hardness: H to 2H Pencil hardness.
3. Evaporator fan compartment interior cabinet insulation shall conform to AHRI Standard 340/360 minimum exterior sweat criteria. Interior surfaces shall be insulated with a minimum 1/2-in. thick, 1-lb density, flexible fiberglass insulation, neoprene coated on the air side. Aluminum foil-faced fiberglass insulation shall be used in the gas heat compartment.
4. Unit internal insulation linings shall be resistant to mold growth in accordance with “mold growth and humidity” test in ASTM C1338, G21, and UL 181 or comparable test method. Air stream surfaces shall be evaluated in accordance with the “Erosion Test” in UL 181, as part of ASTM C1071.
5. Base of unit shall have a minimum of four locations for thru-the-base gas and electrical connections standard. Both gas and electric connections shall be internal to the cabinet to protect from environmental issues.
6. Base rail:
 - a. Unit shall have base rails on a minimum of 2 sides.
 - b. Holes shall be provided in the base rails for rigging shackles to facilitate maneuvering and overhead rigging.
 - c. Holes shall be provided in the base rail for moving the rooftop by fork truck.
 - d. Base rail shall be a minimum of 16-gauge thickness.
7. Condensate pan and connections:
 - a. Shall be a sloped condensate drain pan made of a non-corrosive material.
 - b. Shall comply with ASHRAE Standard 62.
 - c. Shall use a 3/4-in.-14 NPT drain connection, through the side of the drain pan. Connection shall be made per manufacturer’s recommendations.
8. Top panel:
 - a. Shall be a multi-piece top panel linked with water tight flanges and locking systems.
9. Gas connections:
 - a. All gas piping connecting to unit gas valve shall enter the unit cabinet at a single location on side of unit (vertical plane).

b. Thru-the-base capability

- 1) Standard unit shall have a thru-the-base gas-line location using a raised, embossed portion of the unit basepan.
- 2) Thru-the-base provisions / connections are available as standard with every unit. When bottom connections are required, field furnished couplings are required.
- 3) No basepan penetration, other than those authorized by the manufacturer, is permitted.

10. Electrical connections:

- a. All unit power wiring shall enter unit cabinet at a single, factory-prepared, knockout location.
- b. Thru-the-base capability.
 - 1) Thru-the-base provisions/connections are available as standard with every unit. When bottom connections are required, field furnished couplings are required.
 - 2) No basepan penetration, other than those authorized by the manufacturer, is permitted.

11. Component access panels (standard):

- a. Cabinet panels shall be easily removable for servicing.
- b. Unit shall have one factory-installed, removable, filter access panel.
- c. Panels covering control box and filter shall have molded composite handles while the blower access door shall have an integrated flange for easy removal.
- d. Handles shall be UV modified, composite. They shall be permanently attached, and recessed into the panel.
- e. Screws on the vertical portion of all removable access panel shall engage into heat resistant, molded composite collars.
- f. Collars shall be removable and easily replaceable using manufacturer recommended parts.

H. (23 81 19.13.H.) Gas heat:

1. General:

- a. Heat exchanger shall be an induced draft design. Positive pressure heat exchanger designs shall not be allowed.
- b. Shall incorporate a direct-spark ignition system and redundant main gas valve.
- c. Gas supply pressure at the inlet to the rooftop unit gas valve must match that required by the manufacturer.

2. The heat exchanger shall be controlled by an integrated gas controller (IGC) microprocessor.

- a. IGC board shall notify users of fault using an LED (light-emitting diode).
- b. IGC board shall contain algorithms that modify evaporator-fan operation to pre-

- vent future cycling on high temperature limit switch.
- c. Unit shall be equipped with anti-cycle protection with one short cycle on unit flame roll-out switch or 4 continuous short cycles on the high temperature limit switch. Fault indication shall be made using an LED.
3. Standard heat exchanger construction:
 - a. Heat exchanger shall be of the tubular-section type constructed of a minimum of 20-gauge steel coated with a nominal 1.2-mil aluminum-silicone alloy to aid with corrosion resistance.
 - b. Burners shall be of the inshot type constructed of aluminum-coated steel.
 - c. Burners shall incorporate orifices for rated heat output up to 2000 ft (610 m) elevation. Additional accessory kits may be required for applications above 2000 ft (610 m) elevation, depending on local gas supply conditions.
 - d. Each heat exchanger tube shall contain multiple dimples for increased heating effectiveness.
 4. Optional stainless steel heat exchanger construction:
 - a. Use energy saving, direct-spark ignition system.
 - b. Use a redundant main gas valve.
 - c. Burners shall be of the inshot type constructed of aluminum-coated steel.
 - d. All gas piping shall enter the unit cabinet at a single location on side of unit (vertical plane).
 - e. The optional stainless steel heat exchanger shall be of the tubular-section type, constructed of a minimum of 20-gauge type 409 stainless steel.
 - f. Type 409 stainless steel shall be used in heat exchanger tubes and vestibule plate.
 - g. Complete stainless steel heat exchanger allows for greater application flexibility.
 5. Induced draft combustion motor and blower:
 - a. Shall be a direct-drive, single inlet, forward-curved centrifugal type.
 - b. Shall be made from steel with a corrosion-resistant finish.
 - c. Shall have permanently lubricated sealed bearings.
 - d. Shall have inherent thermal overload protection.
 - e. Shall have an automatic reset feature.
- I. (23 81 19.13.I.) Coils:
 1. Standard aluminum fin/copper tube coils:
 - a. Standard evaporator and condenser coils shall have aluminum lanced plate fins mechanically bonded to seamless internally grooved copper tubes with all joints brazed.
 - b. Evaporator coils shall be leak tested to 150 psig, pressure tested to 450 psig, and qualified to UL 1995 burst test at 1775 psig.
 - c. Condenser coils shall be leak tested to 150 psig, pressure tested to 650 psig, and qualified to UL 1995 burst test at 1980 psig.
 2. Optional pre-coated aluminum-fin condenser coils:
 - a. Shall have a durable epoxy-phenolic coating to provide protection in mildly corrosive coastal environments.
 - b. Coating shall be applied to the aluminum fin stock prior to the fin stamping process to create an inert barrier between the aluminum fin and copper tube.
 - c. Epoxy-phenolic barrier shall minimize galvanic action between dissimilar metals.
 - d. Corrosion durability of fin stock shall be confirmed through testing to be no less than 1000 hours salt spray per ASTM B117-90.
 - e. Corrosion durability of fin stock shall be confirmed through testing to have no visible corrosion after a 48-hour immersion in a room temperature solution of 5% salt, 1% acetic acid.
 - f. Fin stock coating shall pass 2000 hours of the following: one week exposure in the prohesion chamber followed by one week of accelerated ultraviolet light testing. Prohesion chamber: the solution shall contain 3.5% sodium chloride and 0.35% ammonium sulfate. The exposure cycle is one hour of salt fog application at ambient followed by one hour drying at 95°F (35°C).
 3. Optional copper-fin evaporator and condenser coils:
 - a. Shall be constructed of copper fins mechanically bonded to copper tubes and copper tube sheets.
 - b. Galvanized steel tube sheets shall not be acceptable.
 - c. A polymer strip shall prevent coil assembly from contacting the sheet metal coil pan to minimize potential for galvanic corrosion between coil and pan.
 4. Optional E-coated aluminum-fin, evaporator and condenser coils:
 - a. Shall have a flexible epoxy polymer coating uniformly applied to all coil surface areas without material bridging between fins.
 - b. Coating process shall ensure complete coil encapsulation of tubes, fins, and headers.

GUIDE SPECIFICATIONS — RGS210-336 (CONT)

- c. Color shall be high gloss black with gloss per ASTM D523-89.
 - d. Uniform dry film thickness from 0.8 to 1.2 mil on all surface areas including fin edges.
 - e. Superior harness characteristics of 2H per ASTM D3363-92A and cross-hatch adhesion of 4B-5B per ASTM D3359-93.
 - f. Impact resistance shall be up to 160 in.-lb (ASTM D2794-93).
 - g. Humidity and water immersion shall be up to minimum 1000 and 250 hours respectively (ASTM D2247-92 and ASTM D870-92).
 - h. Corrosion durability shall be confirmed through testing to be no less than 6000 hours salt spray per ASTM B117-90.
- J. (23 81 19.13.J.) Refrigerant components:
- 1. Refrigerant circuit shall include the following control, safety, and maintenance features:
 - a. Fixed orifice metering system (on non-Humidifier units) provides correct distribution of two-phase refrigerant by including multiple fixed orifice devices in each refrigeration circuit. Each orifice is to be optimized to the coil circuit it serves.
 - b. Thermostatic Expansion Valve (TXV) shall help provide optimum performance across the entire operating range. Shall contain removable power element to allow change out of power element and bulb without removing the valve body.
 - c. Refrigerant filter drier - Solid core design.
 - d. Service gauge connections on suction and discharge lines.
 - e. Pressure gauge access through a specially designed access screen on the side of the unit.
 - 2. Compressors:
 - a. Unit shall use fully hermetic, scroll compressor for each independent refrigeration circuit.
 - b. Models shall be available with 2 compressor/2-stage cooling.
 - c. Compressor motors shall be cooled by refrigerant gas passing through motor windings.
 - d. Compressors shall be internally protected from high discharge temperature conditions.
 - e. Compressors shall be protected from an over-temperature and over-ampereage conditions by an internal, motor overload device.
 - f. Compressor shall be factory mounted on rubber grommets.
 - g. Compressor motors shall have internal line break thermal, current overload and high pressure differential protection.
 - h. Crankcase heaters shall not be required for normal operating range, unless provided by the factory.
- K. (23 81 19.13.K.) Filter section:
- 1. Filters access is specified in the unit cabinet section of this specification.
 - 2. Filters shall be held in place by a preformed, slide-out filter tray, facilitating easy removal and installation.
 - 3. Shall consist of factory-installed, low velocity, throw-away 2-in. thick fiberglass filters.
 - 4. Filters shall be standard, commercially available sizes.
 - 5. Only one size filter per unit is allowed.
 - 6. 4-in. filter capability is possible with a field-installed pre-engineered slide out filter track accessory. 4-in. filters are field furnished.
- L. (23 81 19.13.L.) Evaporator fan and motor:
- 1. Evaporator fan motor:
 - a. Shall have inherent automatic-reset thermal overload protection or circuit breaker.
 - b. Shall have a maximum continuous bhp rating for continuous duty operation; no safety factors above that rating shall be required.
 - 2. Belt-driven evaporator fan:
 - a. Belt drive shall include an adjustable-pitch motor pulley and belt break protection system.
 - b. Shall use rigid pillow block bearing system with lubricant fittings at accessible bearing or lubrication line.
 - c. Blower fan shall be double-inlet type with forward-curved blades.
 - d. Shall be constructed from steel with a finish that aids with corrosion resistance and that is dynamically balanced.
- M. (23 81 19.13.M.) Condenser fans and motors:
- 1. Condenser fan motors:
 - a. Shall be a totally enclosed motor.
 - b. Shall use permanently lubricated bearings.
 - c. Shall have inherent thermal overload protection with an automatic reset feature.
 - d. Shall use a shaft-down design.
 - 2. Condenser fans:
 - a. Shall be a direct-driven propeller type fan.
 - b. Shall have aluminum blades riveted to steel spiders that have corrosion resistant properties and shall be dynamically balanced.
- N. (23 81 19.13.N.) Special features options and accessories:
- 1. Two-Speed Indoor Fan Motor System for 2-stage cooling models only:
 - a. Evaporator fan motor:

- 1) Shall have permanently lubricated bearings.
 - 2) Shall have a maximum continuous bhp rating for continuous duty operation; no safety factors above that rating.
 - 3) Shall be Variable Frequency duty and 2-speed control.
 - 4) Shall contain motor shaft grounding ring to prevent electrical bearing fluting damage by safely diverting harmful shaft voltages and bearing currents to ground.
2. Variable frequency drive (VFD). Only available on 2-speed indoor fan motor option:
 - a. Factory-supplied VFDs qualify, through ABB, for a 12-month warranty from date of commissioning or 18 months from date of sale, whichever occurs first.
 - b. Shall be installed inside the unit cabinet, mounted, wired and tested.
 - c. Shall contain Electromagnetic Interference (EMI) frequency protection.
 - d. Insulated gate bi-polar transistors (IGBT) used to produce the output pulse width modulated (PWM) waveform, allowing for quiet motor operation.
 - e. Self diagnostics with fault and power code LED indicator. Field accessory Display Kit available for further diagnostics and special setup applications.
 - f. RS485 capability standard.
 - g. Electronic thermal overload protection.
 - h. 5% swinging chokes for harmonic reduction and improved power factor.
 - i. All printed circuit boards shall be conformal coated.
 3. Integrated EconoMi\$er® IV and EconoMi\$er X standard leak rate models. (Factory or field-installed):
 - a. Integrated, gear driven opposing modulating blade design type capable of simultaneous economizer and compressor operation.
 - b. Independent modules for vertical return configuration shall be available.
 - c. Damper blades shall be galvanized steel with composite gears. Plastic or composite blades on intake or return shall not be acceptable.
 - d. Shall include all hardware and controls to provide free cooling with outdoor air when temperature and/or humidity are below setpoints.
 - e. Shall be equipped with gear driven dampers for both the outdoor ventilation air and the return air for positive air stream control.
 - f. Standard leak rate models shall be equipped with dampers not to exceed 2% leakage at 1 in. wg pressure differential.
 - g. Economizer controller on EconoMi\$er IV models shall be Honeywell W7212 that provides:
 - 1) Combined minimum and DCV maximum damper position potentiometers with compressor staging relay.
 - 2) Functions with solid state analog enthalpy or dry bulb changeover control sensing.
 - 3) Contain LED indicates for: when free cooling is available, when module is in DCV mode, when exhaust fan contact is closed.
 - h. Economizer controller on EconoMi\$er X models shall be the Honeywell W7220 that provides:
 - 1) 2-line LCD interface screen for setup, configuration, and troubleshooting.
 - 2) On-board Fault Detection and Diagnostics (FDD) that senses and alerts when the economizer is not operating properly, per California Title 24.
 - 3) Sensor failure loss of communication identification.
 - 4) Automatic sensor detection.
 - 5) Capabilities for use with multi-speed indoor fan systems.
 - 6) Utilize digital sensors: dry-bulb and enthalpy.
 - i. Shall be capable of introducing up to 100% outdoor air.
 - j. Shall be equipped with a barometric relief damper capable of relieving up to 100% return air and contain seals that meet ASHRAE 90.1-2016 and IECC-2015 requirements.
 - k. Shall be designed to close damper(s) during loss-of-power situations with spring return built into motor.
 - l. Dry bulb outdoor air temperature sensor shall be provided as standard. Enthalpy sensor is also available for factory-installed economizers only. Outdoor air sensor setpoint shall be adjustable and shall range from 40 to 100°F (4 to 38°C.) Additional sensor options shall be available as accessories.
 - m. The economizer controller shall also provide control of an accessory power exhaust unit function. Factory set at 100%, with a range of 0% to 100%.
 - n. The economizer shall maintain minimum airflow into the building during occupied period and provide design ventilation rate for full occupancy.
 - o. Dampers shall be completely closed when the unit is in the unoccupied mode.
 - p. Economizer controller shall accept a 2-10 Vdc CO₂ sensor input for IAQ/DCV control. In this mode, dampers shall modulate

GUIDE SPECIFICATIONS — RGS210-336 (CONT)

- the outdoor air damper to provide ventilation based on the sensor input.
- q. Compressor lockout temperature on W7220 is adjustable from -45°F to 80°F (43°C to 27°C), set at a factory default of 32°F (0°C). Others shall open at 35°F (2°C) and closes at 50°F (10°C).
 - r. Actuator shall be direct coupled to economizer gear. No linkage arms or control rods shall be acceptable.
 - s. Economizer controller shall provide indications when in free cooling mode, in the DCV mode, or the exhaust fan contact is closed.
4. Integrated EconoMi\$er X Ultra Low Leak rate models. (Factory or field-installed):
- a. Integrated, gear driven opposing modulating blade design type capable of simultaneous economizer and compressor operation.
 - b. Independent modules for vertical return configuration shall be available.
 - c. Damper blades shall be galvanized steel with composite gears. Plastic or composite blades on intake or return shall not be acceptable.
 - d. Shall include all hardware and controls to provide free cooling with outdoor air when temperature and/or humidity are below setpoints.
 - e. Shall be equipped with gear driven dampers for both the outdoor ventilation air and the return air for positive air stream control.
 - f. Ultra Low Leak design meets California Title 24 section 140.4 and ASHRAE 90.1-2016 and IECC-2015 requirements of 4 cfm per sq ft on the outside air dampers and 10 cfm per sq ft on the return dampers.
 - g. Economizer controller on EconoMi\$er X models shall be the Honeywell W7220 that provides:
 - 1) 2-line LCD interface screen for setup, configuration and troubleshooting.
 - 2) On-board Fault Detection and Diagnostics (FDD) that senses and alerts when the economizer is not operating properly, per California Title 24 Fault Detection and Diagnostic (FDD) requirements.
 - 3) Sensor failure loss of communication identification.
 - 4) Automatic sensor detection.
 - 5) Capabilities for use with multiple-speed indoor fan systems.
 - 6) Utilize digital sensors: Dry bulb and Enthalpy.
 - h. Shall be capable of introducing up to 100% outdoor air.
 - i. Shall be equipped with a barometric relief damper capable of relieving up to 100% return air and contain seals that meet ASHRAE 90.1-2016 and IECC-2015 requirements.
- j. Shall be designed to close damper(s) during loss-of-power situations with spring return built into motor.
 - k. Dry bulb outdoor air temperature sensor shall be provided as standard. Enthalpy sensor is also available for factory-installed economizers only. Outdoor air sensor set-point shall be adjustable and shall range from 40 to 100°F (4 to 38°C). Additional sensor options shall be available as accessories.
 - l. The economizer controller shall also provide control of an accessory power exhaust unit function. Factory set at 100%, with a range of 0% to 100%.
 - m. The economizer shall maintain minimum airflow into the building during occupied period and provide design ventilation rate for full occupancy.
 - n. Dampers shall be completely closed when the unit is in the unoccupied mode.
 - o. Economizer controller shall accept a 2-10 Vdc CO₂ sensor input for IAQ/DCV control. In this mode, dampers shall modulate the outdoor air damper to provide ventilation based on the sensor input.
 - p. Compressor lockout temperature on W7220 is adjustable from -45°F to 80°F (43°C to 27°C), set at a factory default of 32°F (0°C). Others shall open at 35°F (2°C) and closes at 50°F (10°C).
 - q. Actuator shall be direct coupled to economizer gear. No linkage arms or control rods shall be acceptable.
 - r. Economizer controller shall provide indications when in free cooling mode, in the DCV mode, or the exhaust fan contact is closed.
5. Two-Position Motorized Damper:
- a. Damper shall be a 2-position damper. Damper travel shall be from the full closed position to the field adjustable %-open setpoint.
 - b. Damper shall include adjustable damper travel from 25% to 100% (full open).
 - c. Damper shall include single or dual blade, gear driven dampers and actuator motor.
 - d. Actuator shall be direct coupled to damper gear. No linkage arms or control rods shall be acceptable.
 - e. Damper will admit up to 100% outdoor air for applicable rooftop units.
 - f. Damper shall close upon indoor (evaporator) fan shutoff and/or loss of power.
 - g. The damper actuator shall plug into the rooftop unit's wiring harness plug. No hard wiring shall be required.

- h. Outside air hood shall include aluminum water entrainment filter.
- 6. Manual damper
 - a. Manual damper package shall consist of damper, air inlet screen, and rain hood which can be preset to admit up to 25% outdoor air for year round ventilation.
- 7. Hot Gas Reheat System (not available on 336 models):
 - a. The Hot Gas Reheat System shall be factory-installed and shall provide greater dehumidification of the occupied space by two modes of dehumidification operations besides its normal design cooling mode:
 - 1) Subcooling mode further sub cools the hot liquid refrigerant leaving the condenser coil when both temperature and humidity in the space are not satisfied.
 - 2) Hot gas reheat mode shall mix a portion of the hot gas from the discharge of the compressor with the hot liquid refrigerant leaving the condenser coil to create a two-phase heat transfer in the system, resulting in a neutral leaving air temperature when only humidity in the space is not satisfied.
 - 3) Includes head pressure controller.
- 8. Head pressure control package:
 - a. Controller shall control coil head pressure by condenser-fan speed modulation or condenser-fan cycling and wind baffles.
 - b. Shall consist of solid-state control and condenser-coil temperature sensor to maintain condensing temperature between 90°F (32°C) and 110°F (43°C) at outdoor ambient temperatures down to -20°F (-29°C).
- 9. Propane conversion kit:
 - a. Package shall contain all the necessary hardware and instructions to convert a standard natural gas unit for use with liquefied propane. Kits shall be available for elevations from 0 up to 14,000 ft (4,267m).
- 10. Condenser coil hail guard assembly:
 - a. Shall protect against damage from hail.
 - b. Shall be louvered style design.
- 11. Unit-mounted, non-fused disconnect switch:
 - a. Switch shall be factory-installed, internally mounted.
 - b. National Electric Code (NEC) and UL approved non-fused switch shall provide unit power shutoff.
 - c. Shall be accessible from outside the unit.
 - d. Shall provide local shutdown and lockout capability.
 - e. Sized only for the unit as ordered from the factory. Does not accommodate field-installed devices.
- 12. Convenience outlet:
 - a. Powered convenience outlet:
 - 1) Outlet shall be powered from main line power to the rooftop unit.
 - 2) Outlet shall be powered from line side of disconnect by installing contractor, as required by code. If outlet is powered from load side of disconnect, unit electrical ratings shall be ETL certified and rated for additional outlet amperage.
 - 3) Outlet shall be factory-installed and internally mounted with easily accessible 115-v female receptacle.
 - 4) Outlet shall include 15 amp GFI receptacles with independent fuse protection.
 - 5) Voltage required to operate convenience outlet shall be provided by a factory-installed step-down transformer.
 - 6) Outlet shall be accessible from outside the unit.
 - 7) Outlet shall include a field-installed "Wet in Use" cover.
 - b. Factory-Installed Non-powered convenience outlet.
 - 1) Outlet shall be powered from a separate 115-120v power source.
 - 2) A transformer shall not be included.
 - 3) Outlet shall be factory-installed and internally mounted with easily accessible 115-v female receptacle.
 - 4) Outlet shall include 15 amp GFI receptacles.
 - 5) Outlet shall be accessible from outside the unit.
 - 6) Outlet shall include a field-installed "Wet in Use" cover.
 - c. Field-Installed Non-powered convenience outlet.
 - 1) Outlet shall be powered from a separate 115-120v power source.
 - 2) A transformer shall not be included.
 - 3) Outlet shall be factory-installed and internally mounted with easily accessible 115-v female receptacle.
 - 4) Outlet shall include 20 amp GFI receptacles. This kit provides a flexible installation method which allows code compliance for height requirements of the GFCI outlet from the finished roof surface as well as the capability to relocate the outlet to a more convenient location.
 - 5) Outlet shall be accessible from outside the unit.
 - 6) Outlet shall include a field-installed "Wet in Use" cover.
- 13. Flue discharge deflector:
 - a. Flue discharge deflector shall direct unit exhaust vertically instead of horizontally.

GUIDE SPECIFICATIONS — RGS210-336 (CONT)

- b. Deflector shall be defined as a “natural draft” device by the National Fuel and Gas (NFG) code.
- 14. Centrifugal propeller power exhaust:
 - a. Power exhaust shall be used in conjunction with an integrated economizer.
 - b. Independent modules for vertical return configurations shall be available.
 - c. Power exhaust shall be controlled by economizer controller operation. Exhaust fans shall be energized when dampers open past the 0-100% adjustable setpoint on the economizer control.
- 15. Roof curbs (vertical):
 - a. Full perimeter roof curb with exhaust capability providing separate air streams for energy recovery from the exhaust air without supply air contamination.
 - b. Formed galvanized steel with wood nailer strip and shall be capable of supporting entire unit weight.
 - c. Permits installation and securing of ductwork to curb prior to mounting unit on the curb.
- 16. High altitude gas conversion kit:
 - a. Package shall contain all the necessary hardware and instructions to convert a standard natural gas unit to operate from 3,000 to 10,000 ft (914 to 3048 m) elevation and 10,001 to 14,000 ft (3049 to 4267 m) elevation.
- 17. Outdoor air enthalpy sensor:
 - a. The outdoor air enthalpy sensor shall be used to provide single enthalpy control. When used in conjunction with a return air enthalpy sensor, the unit will provide differential enthalpy control. The sensor allows the unit to determine if outside air is suitable for free cooling.
- 18. Return air enthalpy sensor:
 - a. The return air enthalpy sensor shall be used in conjunction with an outdoor air enthalpy sensor to provide differential enthalpy control.
- 19. Indoor air quality (CO₂) sensor:
 - a. Shall be able to provide demand ventilation indoor air quality (IAQ) control.
 - b. The IAQ sensor shall be available in duct mount, wall mount, or wall mount with LED display. The setpoint shall have adjustment capability.
- 20. Smoke detectors:
 - a. Shall be a four-wire controller and detector.
 - b. Shall be environmental compensated with differential sensing for reliable, stable, and drift-free sensitivity.
 - c. Shall use magnet-activated test/reset sensor switches.
- d. Shall have tool-less connection terminal access.
- e. Shall have a recessed momentary switch for testing and resetting the detector.
- f. Controller shall include:
 - 1) One set of normally open alarm initiation contacts for connection to an initiating device circuit on a fire alarm control panel.
 - 2) Two Form-C auxiliary alarm relays for interface with rooftop unit or other equipment.
 - 3) One Form-C supervision (trouble) relay to control the operation of the Trouble LED on a remote test/reset station.
 - 4) Capable of direct connection to two individual detector modules.
 - 5) Can be wired to up to 14 other duct smoke detectors for multiple fan shut-down applications.
- 21. Horn/strobe annunciator:
 - a. Provides an audible/visual signaling device for use with factory-installed option or field-installed accessory smoke detectors.
 - 1) Requires installation of a field-supplied 24-v transformer suitable for 4.2 VA (AC) or 3.0 VA (DC) per horn/strobe accessory.
 - 2) Requires field-supplied electrical box, North American 1-gang box, 2-in. (51 mm) x 4-in. (102 mm).
 - 3) Shall have a clear colored lens.
- 22. Winter start kit:
 - a. Shall contain a bypass device around the low pressure switch.
 - b. Shall be required when mechanical cooling is required down to 25°F (-4°C).
 - c. Shall not be required to operate on an economizer when below an outdoor ambient of 40°F (4°C).
- 23. Time guard:
 - a. Shall prevent compressor short cycling by providing a 5-minute delay (±2 minutes) before restarting a compressor after shut-down for any reason.
 - b. One device shall be required per compressor.
- 24. Display kit for variable frequency drive (VFD):
 - a. Kit allows the ability to access the VFD controller programs to provide special setup capabilities and diagnostics.
 - b. Kit contains display module and communication cable.
 - c. Display kit can be permanently installed in the unit or used on any 2-Speed Indoor Fan Motor system VFD controller as needed.

25. Hinged access panels:
- a. Shall provide easy access through hinged access doors with vinyl coated door retainers.
 - b. Shall be on major panels of – filter, control box, and fan motor.

Copyright 2018 International Comfort Products
Lewisburg, Tennessee 37091 USA
www.GoICPCommercial.com