

ASHRAE 90.1 COMPLIANT PACKAGED ROOFTOP ELECTRIC COOLING UNITS, R-410A, 17.5 – 27.5 TONS

BUILT TO LAST, EASY TO INSTALL AND SERVICE

- One-piece, standard efficiency electric cooling with a low profile, prewired, tested, and charged at the factory
- Dedicated vertical or horizontal air flow duct configuration models. No field kits required.
- Full perimeter base rail with built-in rigging adapters and fork truck slots
- Pre-painted exterior panels and primer-coated interior panels tested to 500 hours salt spray protection
- Fully insulated cabinet
- Two-stage cooling with independent circuits and control on all models
- Scroll compressors with internal line-break connections on all models
- All units have high and low pressure switches
- Two inch disposable fiberglass type return air filters in dedicated rack with tool-less filter access door
- Refrigerant circuits contain a liquid line filter drier to trap dirt and moisture
- Round tube plate fin evaporator and condenser coil design
- Exclusive non-corrosive composite condensate pan in accordance with ASHRAE 62 Standard, sloping design; end drain
- Belt drive evaporator-fan motor and pulley combinations available to meet most applications
- Access panels with easy grip handles provide quick and easy access to the blower and blower motor, control box, and compressors.
- "No-strip" screw system has superior holding power and guides screws into position while preventing the screw from stripping the unit's metal.
- Newly designed terminal board facilitates simple safety circuit troubleshooting and simplified control box arrangement
- Standard outdoor temperature cooling operation range up to 115°F (46°C) and down to 30°F (-1°C)
- Fixed orifice metering devices on all models to precisely control refrigerant flow
- Large, laminated control wiring and power wiring drawings are affixed to unit to make troubleshooting easy
- Single point electrical connections

WARRANTY

- 5 Year compressor limited warranty
- 1 Year parts limited warranty



17.5 Ton



20 & 25 Ton



Use of the AHRI Certified TM Mark indicates a manufacturer's participation in the program. For verification of certification for individual products, go to www.ahrirectory.org.



UNIT PERFORMANCE DATA – Two Stage Cooling							
UNIT	Dedicated Airflow	Nominal Tons	COOLING		Total Power (kW)	Unit Dimensions H x W x L	Unit Weight lb. [kg]
			Net Cap. (Btuh)	EER			
RAS210*0AA0AAA	Vertical	17.5	207,000	11.0	18.8	49-3/8" x 86-5/8" x 127-7/8"	2243 [1017]
RAS213*0AA0AAA	Horizontal	17.5	207,000	11.0	18.8	49-3/8" x 86-5/8" x 127-7/8"	2243 [1017]
RAS240*0AA0AAA	Vertical	20	242,000	10.0	24.2	49-3/8" x 86-5/8" x 141-1/2"	2277 [1033]
RAS243*0AA0AAA	Horizontal	20	242,000	10.0	24.2	49-3/8" x 86-5/8" x 141-1/2"	2277 [1033]
RAS300*0AA0AAA	Vertical	25	280,000	10.0	28.0	57-3/8" x 86-5/8" x 141-1/2"	2525 [1145]
RAS303*0AA0AAA	Horizontal	25	280,000	10.0	28.0	57-3/8" x 86-5/8" x 141-1/2"	2525 [1145]
RAS336*0AA0AAA	Vertical	27.5	330,000	10.4	31.7	57-3/8" x 86-5/8" x 157-3/4"	2513 [1142]
RAS333*0AA0AAA	Horizontal	27.5	330,000	10.4	31.7	57-3/8" x 86-5/8" x 157-3/4"	2513 [1142]

* Indicates Unit voltage: H = 208/230-3-60, L = 460-3-60, S = 575-3-60

NOTE: BASE MODEL NUMBERS LISTED. SEE MODEL NOMENCLATURE LISTING FOR ADDITIONAL OPTIONS

TABLE OF CONTENTS

	PAGE		PAGE
MODEL NUMBER NOMENCLATURE	3	COOLING TABLES	24
FACTORY OPTIONS AND/OR ACCESSORIES	4	STATIC PRESSURE ADDERS	31
AHRI COOLING RATING TABLE	10	FAN PERFORMANCE	33
MINIMUM AIRFLOWS ELECTRIC	10	OUTDOOR AIR INTAKE & EXHAUST PERF	37
SOUND PERFORMANCE TABLE	10	ELECTRICAL DATA FOR UNITS PRODUCED ON OR AFTER JULY 30, 2012	38
PHYSICAL DATA	11	ELECTRICAL DATA FOR UNITS PRODUCED PRIOR TO JULY 30, 2012	57
CURBS & WEIGHTS DIMENSIONS	13	SEQUENCE OF OPERATION	73
OPTIONS AND ACCESSORY WEIGHT ADDERS ...	22	GUIDE SPECIFICATIONS	75
APPLICATION DATA	23		

3 to 27.5 TON ROOFTOP UNIT FIOP CODES (Use with Model Nomenclature on next page)			
OPTION	DESCRIPTION	NOMENCLATURE	
		CODE	OPTIONS
2	Non-Fused Disconnect Switch	0A	None
4	Easy Access Hinged Panels	4B	2
5	Unpowered Convenience Outlet	7C	2, 5
9	Supply Air Smoke Detector	7K	2, 5, 9
		8A	2, 9
		AT	5
		BA	5, 9
		AA	4
		6C	2, 4
		6D	2, 4, 5
		6L	2, 4, 5, 9
		7B	2, 4, 9
		AB	4, 5
		AJ	4, 5, 9
		CH	4, 9
		BR	9

MODEL NOMENCLATURE

MODEL SERIES	R	A	S	2	1	0	H	0	A	B	0	A	A	A
Position Number	1	2	3	4	5	6	7	8	9	10	11	12	13	14
R = Rooftop														
A = Air Conditioning (Cooling Only) G = Gas/Electric Type														
S = Standard ASHRAE 90.1-2010 Efficiency Efficiency														
210 = 210,000 = 17.5 Tons Dedicated Vertical SA/RA = Supply Air, RA = Return Air 213 = 210,000 = 17.5 Tons Dedicated Horizontal SA/RA 240 = 240,000 = 20 Tons Dedicated Vertical SA/RA 243 = 240,000 = 20 Tons Dedicated Horizontal SA/RA 300 = 300,000 = 25 Tons Dedicated Vertical SA/RA 303 = 300,000 = 25 Tons Dedicated Horizontal SA/RA 336 = 300,000 = 25 Tons Dedicated Vertical SA/RA 333 = 300,000 = 25 Tons Dedicated Horizontal SA/RA Nominal Cooling Capacity														
H = 208/230-3-60 L = 460-3-60 S = 575-3-60 Voltage														
0 = No Heat Heating Capacity														
A = Standard Static Option (All models) B = High Static High Efficiency Option (All models with 2 speed IFM) C = Medium Static Option (17.5 Ton Only with 1 speed IFM) C = Medium Static High Efficiency Option (17.5 to 27.5 ton with 2 speed IFM) E = High Static High Efficiency Option (All Models with 1 speed IFM) F = Medium Static High Efficiency Option (20 to 27.5 Ton) G = High Static Motor with Hot Gas Reheat (17.5 to 25 Ton) Motor Option														
A = None B = Economizer w/Bara-relief, OA Temp sensor E = Economizer w/Bara-relief + CO ₂ sensor, OA Temp sensor H = Economizer w/Bara-relief, Enthalpy sensor L = Economizer w/Bara-relief + CO ₂ sensor, Enthalpy sensor U = Ultra Low Leak Temp Economizer w/Baro relief W = Ultra Low Leak Enthalpy Economizer w/Baro relief P = 2-Position damper w/Baro-relief Outdoor Air Options / Control														
OA = No Options AT = Non-powered 115v C.O. BR = Sup. Air Smoke Detector AA = Easy Access Hinged Panels 4B = Non fused disconnect Factory Installed Options														
A = Alum / Cu Cond & Alum / Cu Evap B = Pre coated Alum / Cu Cond & Alum / Cu Evap C = E-coated Alum / Cu Cond & Alum / Cu Evap D = E-coated Alum / Cu Cond & E-coated Alum / Cu Evap E = Cu / Cu Cond & Alum / Cu Evap F = Cu / Cu Cond, Cu / Cu Evap Condenser / Evaporator Coil Configuration														
A = Standard 1 Speed IFM T = 2 Speed IFM with VFD Controller (For 2-stage units only) Motor Type Option														

Table 1 – FACTORY INSTALLED OPTIONS AND FIELD INSTALLED ACCESSORIES

CATEGORY	ITEM	FACTORY INSTALLED OPTION	FIELD INSTALLED ACCESSORY
Cabinet	Dedicated Vertical Air Flow Duct Configuration	X	
	Dedicated Horizontal Air Flow Duct Configuration	X	
Coil Options	Cu/Cu (indoor) Coils	X	
	Pre-Coat (outdoor) Coils	X	
	E-coated (outdoor & indoor) coils	X	
Humidity Control	Hot Gas Reheat	X	
Condenser Protection	Condenser coil hail guard (louvered design)		X
Controls	Smoke detector (supply air)	X	X
	Time Guard II compressor delay control circuit		X
	Phase Monitor		X
Economizers & Outdoor Air Dampers	Economizer IV	X	X
	Motorized 2 position outdoor-air damper	X	X
	Manual outdoor-air damper (25%)		X
	Barometric relief ¹	X	X
	Barometric hood (Horizontal economizer)		X
	Power exhaust-centrifugal blower		X
	Ultra Low Leak Economizer X (for 2-Speed Indoor Fan Motor System only, 17 to 30 sizes with 2 stages of cooling), vertical supply and return air only.	X	X
Economizer Sensors & IAQ Devices	Single dry bulb temperature sensors ²	X	X
	Single enthalpy sensors ²	X	X
	Differential enthalpy sensors ²		X
	Duct mounted CO ₂ sensor ²		X
	4-in Filter Track Assembly		X
Heat	Electric Heat (Vertical or Horizontal Duct Configuration)		X
	Single Point Kit		X
Indoor Motor & Drive	Multiple motor and drive packages	X	
	2-Speed Indoor Fan Motor System w/VFD controller (2-stage cool only with electrical mechanical controls)	X	
Low Ambient Control	Winter start kit ³		X
	Motormaster head pressure controller ³		X
Power Options	Convenience outlet (unpowered)	X	
	Non-fused disconnect ⁴	X	
Roof Curbs	Roof curb 14-in (356mm)		X
	Roof curb 24-in (610mm)		X

NOTES:

1. Included with economizer.
2. Sensors used to optimize economizer performance.
3. See application data for assistance.
4. Non-fused disconnect switch cannot be used when MOCP electrical rating exceeds 70 amps at 460/575 volt and 150 amps at 208/230 volt.

FACTORY OPTIONS AND/OR ACCESSORIES

Economizer (dry–bulb or enthalpy)

Economizers save money. They bring in fresh, outside air for ventilation; and provide cool, outside air to cool your building. This is the preferred method of low–ambient cooling. When coupled to CO₂ sensors, economizers can provide even more savings by coupling the ventilation air to only that amount required.

Economizers are available, installed and tested by the factory, with either enthalpy or dry–bulb temperature inputs. Additional sensors are available as accessories to optimize the economizers.

Economizers include gravity controlled, barometric relief equalizes building pressure and ambient air pressures. This can be a cast effective solution to prevent building pressurization. If further control of exhaust air is required, a dual centrifugal fan power exhaust system is also available.

CO₂ Sensor

Improves productivity and saves money by working with the economizer to intake only the correct amount of outside air for ventilation. As occupants fill your building, the CO₂ sensor detects their presence through increasing CO₂ levels, and opens the economizer appropriately.

When the occupants leave, the CO₂ levels decrease, and the sensor appropriately closes the economizer. This intelligent control of the ventilation air, called Demand Control Ventilation (DCV) reduces the overall load on the rooftop.

Smoke Detector

Smoke detectors make your application safer and your job easier. Smoke detectors immediately shut down the rooftop unit when smoke is detected. It is available for supply air.

Louvered Hail Guards (accessory only)

Sleek, louvered panels protect the condenser coil from hail damage, foreign objects, and incidental contact.

Convenience Outlet (un–powered)

Reduce service and/or installation costs by including a convenience outlet in your specification. The convenience outlet provides a 15 amp, 115v GFCI receptacle with “Wet in Use” cover. This option is to be powered from a separate 115/120v power source.

Non–Fused Disconnect

This OSHA–compliant, factory–installed, safety switch allows a service technician to locally secure power to the rooftop capable of providing protection to a MOCP maximum of 200A.

Power Exhaust with Barometric Relief

Superior internal building pressure control. This field–installed accessory may eliminate the need for costly, external pressure control fans.

Time Guard II Control Circuit

This accessory protects your compressor by preventing short–cycling in the event of some other failure, prevents the compressor from restarting for 30 seconds after stopping.

Motorized 2–Position Damper

The new 2–position, motorized outdoor air damper admits up to 100% outside air. Using reliable, gear–driven technology, the 2–position damper opens to allow ventilation air and closes when the rooftop stops, stopping unwanted infiltration.

Manual OA Damper (accessory only)

Manual outdoor air dampers are an economical way to bring in ventilation air. The dampers are available in 25% versions.

Motormaster Head Pressure Controller

The Motormaster motor controller is a low ambient, head pressure controller kit that is designed to maintain the unit’s condenser head pressure during periods of low ambient cooling operation. This device should be used as an alternative to economizer free cooling not when economizer usage is either not appropriate or desired. The Motormaster will either cycle the outdoor–fan motors or operate them at reduced speed to maintain the unit operation, depending on the model.

Winter Start Kit (accessory only)

The winter start kit extends the low ambient limit of your rooftop to 25°F (–4°C). The kit bypasses the low pressure switch, preventing nuisance tripping of the low pressure switch. Other low ambient precautions may still be prudent.

High Static Motors and Drives

Some applications need larger horsepower motors, some need more airflow, and some need both. Regardless of the case, your dealer has a factory installed combination to meet your application. A wide selection of motors and pulleys (drives) are available, factory installed, to handle nearly any application.

Filter or Fan Status Switches

Use these differential pressure switches to detect a filter clog or indoor fan motor failure. When used in conjunction with a compatible unit controller/thermostat, the switches will activate an alarm to warn the appropriate personnel.

Electric Heaters / Single Point Kit

A full–line of field–installed accessory heaters and single point kits are available when required. The heaters are very easy to use, install and are all pre–engineered and certified.

Barometric Hood (accessory only)

For Horizontal Economizer applications where relief damper is installed in duct work. This kit provides the needed protection.

FACTORY OPTIONS AND/OR ACCESSORIES (CONT.)

Hot Gas Reheat System

Hot Gas Reheat is an all-inclusive factory installed option that can be ordered with RAS units.

This system expands the envelope of operation of rooftop products to provide unprecedented flexibility to meet year round comfort conditions.

The Hot Gas Reheat has the industry's only dual dehumidification mode setting. The Hot Gas Reheat System includes two new modes of operation.

RAS rooftop units coupled with the Hot Gas Reheat is capable of operating in normal design cooling mode, subcooling mode, and hot gas reheat mode. Normal design cooling mode is when the unit will operate under its normal sequence of operation by cycling compressors to maintain comfort conditions.

Subcooling mode will operate to satisfy part load type conditions when the space requires combined sensible and a higher proportion of latent load control. Hot Gas Reheat mode will operate when outdoor temperatures diminish and the need for latent capacity is required for sole humidity control. Hot Gas Reheat mode will provide neutral air for maximum dehumidification operation.

2-Speed Indoor Fan Motor System

The 2-Speed Indoor Fan Motor System saves energy and installation time by utilizing a Variable Frequency Drive (VFD) to automatically adjust the indoor fan motor speed in sequence with the units cooling operation. Per ASHRAE 90.1 2010 standard section 6.4.3.10.b, during the first stage of cooling operation the VFD will adjust the fan motor to provide 2/3rd of the total cfm established for the unit. When a call for the second stage of cooling is required, the VFD will allow the total cfm for the unit established (100%). During the heating mode the VFD will allow total design cfm (100%) operation and during the ventilation mode the VFD will allow operation to 2/3rd of total cfm.

Compared to single speed indoor fan motor systems, the 2-Speed Indoor Fan Motor System can save substantial energy, 25%+*, versus single speed indoor fan motor systems.

The VFD used in the 2-Speed Indoor Fan Motor System has soft start capabilities to slowly ramp up the speeds, thus eliminating any high inrush air volume during initial start-up. It also has internal over current protection for the fan motor and a field installed display kit that allows adjustment and in depth diagnostics of the VFD.

This 2-Speed Indoor Fan Motor System is available on models with 2-stage cooling operation with electrical mechanical or RTU Open, Multi Protocol controls. Both space sensor and conventional thermostats controls can be used to provide accurate control in any application.

The 2-Speed Indoor Fan Motor System is very flexible for initial fan performance set up and adjustment. The standard factory shipped VFD is pre-programmed to automatically stage the fan speed between the first and second stage of cooling. The unit fan performance static pressure and cfm can be easily adjusted using the traditional means of pulley adjustments. The other means to adjust the unit static and cfm performance is to utilize the field installed Display Kit and adjust the frequency and voltage in the VFD to required performance requirements. In either case, once set up, the VFD will automatically adjust the speed between the cooling stage operations.

ACCESSORIES – RAS210–336

FLAT ROOF CURBS		
Model Number	Description	Use With Model Size
CRRFCURB045A00	14" High Roof Curb – 14-inch Tall Roof Curb. Complies with NRCA standards. Ductwork attaches to the roof curb. Includes thru-the -bottom capability.	210/213
CRRFCURB047A00		240/243 – 300/303
CRRFCURB046A00	24" High Roof Curb – 24-inch Tall Roof Curb. Complies with NRCA standards. Ductwork attaches to the roof curb. Includes thru-the -bottom capability.	210/213
CRRFCURB048A00		240/243 – 300/303
CRRFCURB049A00	14" High Roof Curb – 14-inch Tall Roof Curb. Complies with NRCA standards. Ductwork attaches to the roof curb. Includes thru-the -bottom capability.	336/333
CRRFCURB050A00	24" High Roof Curb – 24-inch Tall Roof Curb. Complies with NRCA standards. Ductwork attaches to the roof curb. Includes thru-the -bottom capability.	336/333

ECONOMIZER IV		
Model Number	Description	Use With Model Size
DNECOMZR052A00 ¹²	Vertical and Horizontal Economizer IV with solid-state controller, gear-driven, modulating damper, spring return actuator, up to 100% barometric relief, supply and outdoor air sensors and outdoor air hood. CO2 sensor compatible	210/213 – 240/243
DNECOMZR053A00 ¹²		300/303 – 336/333

¹ Economizer IV cannot be installed with an Economizer X, Manual Damper or Motorized Damper or any other DDC controller models.

² Barometric relief must be installed in return ductwork on Horizontal configured models (213, 243, 303 & 333)

ECONOMIZER X		
Model Number	Description	Use With Model Size
DNECOMZR074A00 ¹²	Ultra LOW LEAK – Vertical Economizer X with solidstate W7220 controller, gear-driven, modulating damper, spring return actuator, up to 100% barometric relief, supply and outdoor air sensors, and CO2 sensor compatible, for use in electro mechanical controls only.	210/213 – 240/243
DNECOMZR075A00 ¹²		300/303 – 336/333

¹ Economizer IV cannot be installed with an Economizer X, Manual Damper or Motorized Damper or any other DDC controller models.

² Can only be used on electrical mechanical units with 2 stage cooling and 2 speed fan control.

ECONOMIZER SENSORS		
Model Number	Description	Use With Model Size
DNTEMPSN002A00	Single (dry bulb) Control	Economizer IV
DNCBDIOX005A00	CO2 Sensor and aspirator box for use in return airstream.	Economizer IV, X
DNENTDIF004A00	Return Air Enthalpy Sensor	Economizer IV
AXB078ENT	Enthalpy Control	Economizer IV
CRTEMPSN005A00	Outdoor or Return Dry Bulb Temp Sensor	Economizer X
HH57AC081	Enthalpy control (One required for single enthalpy, two for differential)	Economizer X

BAROMETRIC RELIEF HOOD		
Model Number	Description	Use With Model Size
CRBARHOD001A00	For horizontal economizer applications where relief damper is installed in duct work, this kit provides needed protection	All Horizontal Economizers

POWER EXHAUST*		
Model Number	Description	Use With Model Size
CRPWREXH068A00	Vertical and Horizontal, 208/230–3–60	210/213–240/243–300/303–336/333
CRPWREXH069A00	Vertical and Horizontal, 460–3–60	210/213–240/243–300/303–336/333
CRPWREXH070A00	Vertical and Horizontal, 575–3–60	210/213–240/243–300/303–336/333

* When power exhaust is used on horizontal applications, it must be field mounted to the side of the return duct.

Power exhaust can be used with Economizer IV or X, controlled by the Economizer controller.

MANUAL OUTDOOR AIR DAMPERS		
Model Number	Description	Use With Model Size
CRMANDPR009A00	25% Open Manual Fresh Air Damper	210/213 – 240/243
CRMANDPR010A00	25% Open Manual Fresh Air Damper	300/303–336/333

MOTORIZED OUTDOOR AIR DAMPERS		
Model Number	Description	Use With Model Size
CRTWOPOS012A00	Motorized 2 position outdoor air damper	210/213–240/243
CRTWOPOS013A00	Motorized 2 position outdoor air damper	300/303–336/333

ACCESSORIES – RAS210–336 (cont.)

LOW AMBIENT CONTROLS		
Model Number	Description	Use With Model Size
CRLOWAMB041A00 ¹	Motormaster® I –20° Low Ambient Control 208/230–3–60	210/213–240/243–300/303–336/333
CRLOWAMB042A00 ¹	Motormaster® I –20° Low Ambient Control 460–3–60, 575–3–60	210/213–240/243–300/303–336/333
CRTRXKIT001A00	Motormaster® I –20° Transformer 575–3–60 Must be used in conjunction with Low Ambient Controller if used on 575–3–60 models.	210/213–240/243–300/303–336/333

¹ Also requires one DNWINSTR001A00 winter start kit per circuit.

CONTROL UPGRADE KITS		
Model Number	Description	Use With Model Size
CRDISKIT001A00	2–Speed VFD display kit provides the field capability to set up points and troubleshooting codes on the VFD controller. Can be used for any associated unit with VFD.	All 2–Speed VFD Controllers
CRPHASE3001A02	Electronic Phase Monitor – All 208/230/460–3–60 models	210/213–240/243–300/303–336/333
CRPHASE3002A00	Electronic Phase Monitor – All 575–3–60 models	210/213–240/243–300/303–336/333
CRSTATUS005A00	Fan/filter Status Switch – Indicator light not included	210/213–240/243–300/303–336/333
NRTIMEGD001A00	Time Guard II	210/213–240/243–300/303–336/333
CRSDTEST001A00	Smoke detector remote Test/Reset/Alarm indicator kit	210/213–240/243–300/303–336/333
CRSMKSEN002A00	Smoke Detector Control Module	210/213–240/243–300/303–336/333
CRSMKKIT002A00	Smoke Detector Control Module (Smoke Detector Sensor with sampling tube & exhaust tube)	210/213–240/243–300/303–336/333
DNWINSTR001A00	Winter Start Kit – Contains time delay relay for timed bypass of low pressure switch on start–up	210/213–240/243–300/303–336/333

4" FILTER TRACK UPGRADE KIT		
Model Number	Description	Use With Model Size
CRFLTTRK001A00	4" Field Conversion Kit	210/213–240/243–300/303–336/333

LOUVERED HAIL GUARDS		
Model Number	Description	Use With Model Size
CRLVHLGD017A00	Louvered Condenser Coil Hail Guard	210/213
CRLVHLGD027A00	Louvered Condenser Coil Hail Guard	240/243
CRLVHLGD028A00	Louvered Condenser Coil Hail Guard	300/303
CRLVHLGD029A00	Louvered Condenser Coil Hail Guard	336/333

ELECTRIC HEAT – HORIZONTAL DUCT CONFIGURATION		
Model Number	Nominal kW	Use With Model Size
CRHEATER270A00	25.0	All Horizontal Duct 208/230v Models
CRHEATER271A00	50.0	
CRHEATER272A00	75.0	
CRHEATER273A00	25.0	All Horizontal Duct 460v Models
CRHEATER274A00	50.0	
CRHEATER275A00	75.0	
CRHEATER276A00	25.0	All Horizontal Duct 575v Models
CRHEATER277A00	50.0	
CRHEATER278A00	75.0	
ELECTRIC HEAT – VERTICAL DUCT CONFIGURATION		
Model Number	Nominal kW	Use With Model Size
CRHEATER279A00	25.0	All Vertical Duct 208/230v Models
CRHEATER280A00	50.0	
CRHEATER281A00	75.0	
CRHEATER282A00	25.0	All Vertical Duct 460v Models
CRHEATER283A00	50.0	
CRHEATER284A00	75.0	
CRHEATER285A00	25.0	All Vertical Duct 575v Models
CRHEATER286A00	50.0	
CRHEATER287A00	75.0	
SINGLE POINT CONNECTION KIT		
Model Number	Description	Use With Electric Heater
CRSINGLE056A00	Single Point Connection for 208/230V 75kW Heaters	CRHEATER272A00 CRHEATER281A00
CRSINGLE057A00	Single Point Connection for 460V & 575V 75kW Heaters	CRHEATER275A00 CRHEATER278A00 CRHEATER284A00 CRHEATER287A00

Table 2 – AHRI COOLING RATING TABLE

MODEL RAS	COOLING STAGES	NOMINAL CAPACITY (TONS)	NET COOLING CAPACITY (MBH)	TOTAL POWER (kW)	EER	IEER WITH 1-SPEED IFM	IEER WITH 2-SPEED IFM
210 – 213	2	17.5	208.0	18.8	11.0	11.8	12.9
240 – 243	2	20	242.0	24.2	10.0	10.8	11.9
300 – 303	2	25	282.0	28.0	10.0	10.6	11.7
336 – 333	2	27.5	330.0	31.7	10.4	10.6	11.7

LEGEND

AHRI – Air-Conditioning, Heating & Refrigeration Institute
 ASHRAE – American Society of Heating, Refrigerating and Air Conditioning, Inc.
 EER – Integrated Energy Efficiency Ratio
 IPLV – Integrated Part Load Value

NOTES:

1. Rated and certified under AHRI Standard 340/360-04, as appropriate.
 2. Ratings are based on:
Cooling Standard: 80°F (27°C) db, 67°F (19°C) wb indoor air temp and 95°F (35°C) db outdoor air temp.
IPLV Standard: 80°F (27°C) db, 67°F (19°C) wb indoor air temp and 80°F (27°C) db outdoor air temp.
 3. All RAS units comply with ASHRAE 90.1 2001, 2004 Energy Standard for minimum SEER and EER requirements.
 4. RAS units comply with US Energy Policy Act (2005). To evaluate code compliance requirements, refer to state and local codes or visit the following website: <http://bcap-energy.org> to determine if compliance with this standard pertains to your state, territory, or municipality.



Use of the AHRI Certified TM Mark indicates a manufacturer's participation in the program. For verification of certification for individual products, go to www.ahridirectory.org.

Table 3 – MINIMUM AIRFLOWS ELECTRIC HEAT

MODEL SIZE	NOMINAL kW	ELECTRIC HEATERS		COOLING			
		MINIMUM	MAXIMUM	Minimum Single Speed Fan Motor	Minimum 2-speed Fan Motor (at high speed)	Minimum 2-speed Fan Motor (at low speed)	Maximum
210 – 213	25	5200	9000	5250	5250	3465	9000
	50						
	75						
240 – 243	25	6000	10000	6000	6000	3960	10000
	50						
	75						
300 – 303	25	7000	12500	7500	8450	5577	12500
	50						
	75						
336 – 333	25	8500	15000	8250	8250	5445	13750
	50						
	75						

Table 4 – SOUND PERFORMANCE TABLE

MODEL RAS	COOLING STAGES	Outdoor Sound (dB)									
		A-Wtg.	AHRI 370 Rating	63	125	250	500	1000	2000	4000	8000
210 – 213	2	84.1	84	92.2	83.9	80.4	81.8	78.7	76.5	72.2	65.4
240 – 243	2	86.5	87	95.6	87.5	84.2	84.2	81.7	77.9	73.2	66.3
300 – 303	2	85.9	86	97.1	88.3	84.4	83.3	80.7	77.4	73.4	67.3
336 – 333	2	85.9	86	97.1	88.3	84.4	83.3	80.7	77.4	73.4	67.3

LEGEND

dB – Decibel

NOTES:

1. Outdoor sound data is measured in accordance with AHRI standard 270-2008.
 2. Measurements are expressed in terms of sound power. Do not compare these values to sound pressure values because sound pressure depends on specific environmental factors which normally do not match individual applications. Sound power values are independent of the environment and therefore more accurate.

3. A-weighted sound ratings filter out very high and very low frequencies, to better approximate the response of "average" human ear. A-weighted measurements are taken in accordance with AHRI standard 270-2008.

Table 5 – PHYSICAL DATA (COOLING) 17.5 – 27.5 TONS

		210/213	240/243	300/303	336/333
Refrigeration System					
	# Circuits / # Comp. / Type	2 / 2 / Scroll	2 / 2 / Scroll	2 / 2 / Scroll	2 / 2 / Scroll
	R-410a charge A/B (lbs)	9.5/12.0	20.6/14.7	19.8/20.4	27.0/ 28.5
	Hot Gas Reheat R-410a charge A/B (lbs)	25.9/25.7	27.9/20.5	27.9/28.9	n/a
	Metering device	Acutrol	Acutrol	Acutrol	Acutrol
	High–press. Trip / Reset (psig)	630 / 505	630 / 505	630 / 505	630 / 505
	Low–press. Trip / Reset (psig)	54 / 117	54 / 117	54 / 117	54 / 117
	Hot Gas Reheat Low–press. Trip/Reset (psig)	27 / 44	27 / 44	27 / 44	n/a
	Compressor Capacity Staging (%)	50 / 100	50 / 100	50 / 100	50 / 100
Evap. Coil					
	Material	Cu / Al	Cu / Al	Cu / Al	Cu / Al
	Tube Diameter	3/8–in	3/8–in	3/8–in	3/8–in
	Rows / FPI	4 / 15	4 / 15	4 / 15	4 / 15
	Total face area (ft2)	22.00	22.00	23.11	26
	Condensate drain conn. size	3/4–in	3/4–in	3/4–in	3/4–in
Hot Gas Reheat Coil					
	Material	Cu / Al	Cu / Al	Cu / Al	n/a
	Tube Diameter	3/8–in	3/8–in	3/8–in	n/a
	Rows / FPI	1 / 17	1 / 17	1 / 17	n/a
	Total face area (ft2)	22.00	22.00	23.11	n/a
Evap. fan and motor VERTICAL					
		210	240	300	336
Standard Static	Motor Qty / Drive type	1 / Belt	1 / Belt	1 / Belt	1 / Belt
	Max BHP	3.3	4.9	4.9	6.5
	RPM range	622–822	690–863	717–911	751–954
	Motor frame size	56	56	56	56
	Fan Qty / Type	2 / Centrifugal	2 / Centrifugal	2 / Centrifugal	2 / Centrifugal
	Fan Diameter (in)	15 x 15	15 x 15	15 x 15	15 x 15
Medium Static	Motor Qty / Drive type	1 / Belt	1 / Belt	1 / Belt	1 / Belt
	Max BHP	4.9	6.5	6.5	10.5
	RPM range	713–879	835–1021	913–1116	920–1190
	Motor frame size	56	184T	184T	184T
	Fan Qty / Type	2 / Centrifugal	2 / Centrifugal	2 / Centrifugal	2 / Centrifugal
	Fan Diameter (in)	15 x 15	15 x 15	15 x 15	15 x 15
High Static	Motor Qty / Drive type	1 / Belt	1 / Belt	1 / Belt	1 / Belt
	Max BHP	6.5	8.7	8.7	11.9
	RPM range	882–1078	941–1176	941–1176	1015–1299
	Motor frame size	56	213T	213T	213T
	Fan Qty / Type	2 / Centrifugal	2 / Centrifugal	2 / Centrifugal	2 / Centrifugal
	Fan Diameter (in)	15 x 15	15 x 15	15 x 15	15 x 15

Table 6 – PHYSICAL DATA (COOLING) 17.5 – 27.5 TONS

RAS		213	243	303	333
Evap. fan and motor HORIZONTAL					
Standard Static	Motor Qty / Drive type	1 / Belt	1 / Belt	1 / Belt	1 / Belt
	Max BHP	3.3	4.9	4.9	6.5
	RPM range	622–822	690–863	647–791	687–873
	Motor frame size	56	56	56	184T
	Fan Qty / Type	2 / Centrifugal	2 / Centrifugal	2 / Centrifugal	2 / Centrifugal
	Fan Diameter (in)	18 x 15 & 15 X 11	18 x 15 & 15 X 11	18 x 15 & 15 X 11	18 x 15 / 15 X 11
Medium Static	Motor Qty / Drive type	1 / Belt	1 / Belt	1 / Belt	1 / Belt
	Max BHP	4.9	6.5	6.5	10.5
	RPM range	713–879	835–1021	755–923	857–1047
	Motor frame size	56	184T	184T	213T
	Fan Qty / Type	2 / Centrifugal	2 / Centrifugal	2 / Centrifugal	2 / Centrifugal
	Fan Diameter (in)	18 x 15 & 15 X 11	18 x 15 & 15 X 11	18 x 15 & 15 X 11	18 x 15 / 15 X 11
High Static	Motor Qty / Drive type	1 / Belt	1 / Belt	1 / Belt	1 / Belt
	Max BHP	6.5	8.7	8.7	11.9
	RPM range	882–1078	941–1176	827–1010	994–1197
	Motor frame size	184T	213T	213T	215T
	Fan Qty / Type	2 / Centrifugal	2 / Centrifugal	2 / Centrifugal	2 / Centrifugal
	Fan Diameter (in)	18 x 15 & 15 X 11	18 x 15 & 15 X 11	18 x 15 & 15 X 11	18 x 15 / 15 X 11
Cond. Coil (Circuit A)					
	Coil type	RTPF	RTPF	RTPF	RTPF
	Coil Length (in)	70	82	75	95
	Coil Height (in)	44	44	52	52
	Total face area (ft2)	21.4	25.1	27.1	34.3
Cond. Coil (Circuit B)					
	Coil type	RTPF	RTPF	RTPF	RTPF
	Coil Length (in)	70	57	75	95
	Coil Height (in)	44	44	52	52
	Total face area (ft2)	21.4	17.4	27.1	34.3
Cond. fan / motor					
	Qty / Motor drive type	3 / direct	4 / direct	4 / direct	6 / direct
	Motor HP / RPM	1/4 / 1100	1/4 / 1100	1/4 / 1100	1/4 / 1100
	Fan diameter (in)	22	22	22	22
Filters					
	RA Filter # / size (in)	6 / 20 x 25 x 2	6 / 20 x 25 x 2	9 / 16 x 25 x 2	9 / 16 x 25 x 2
	OA inlet screen # / size (in)	4 / 16 x 25 x 1	4 / 16 x 25 x 1	4 / 16 x 25 x 1	4 / 16 x 25 x 1

BASE UNIT DIMENSIONS – RAS210/213

CONNECTION SIZES	
A	1 3/8" DIA [35] FIELD POWER SUPPLY KNOCKOUT
B	3" DIA [76] FIELD POWER SUPPLY KNOCKOUT
C	3 5/8" DIA [92] FIELD POWER SUPPLY KNOCKOUT
D	7/8" DIA [22] FIELD CONTROL WIRING HOLE
E	3/4"-14 NPT CONDENSATE DRAIN

NOTES:

1. DIMENSIONS ARE IN INCHES, DIMENSIONS IN [] ARE IN MILLIMETERS.
2. CENTER OF GRAVITY
3. DIRECTION OF AIR FLOW

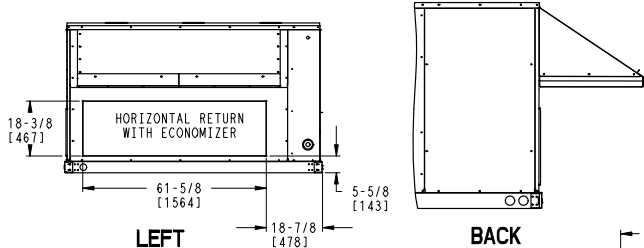
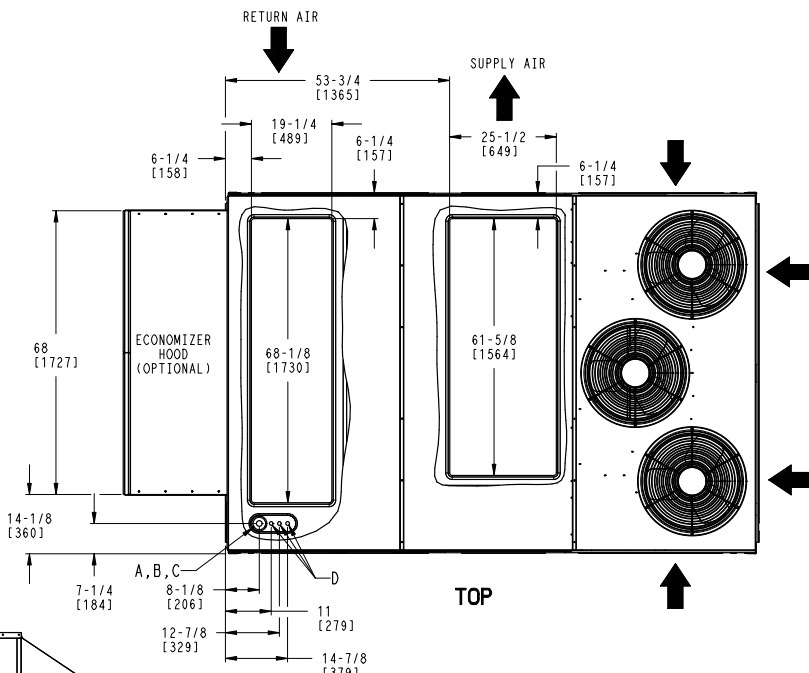

(HORIZONTAL DISCHARGE W/ ECON)
(WHEN ORDERED)

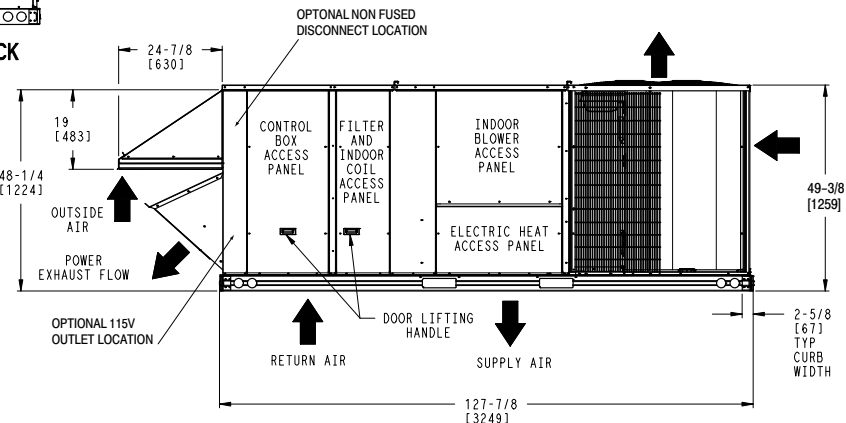
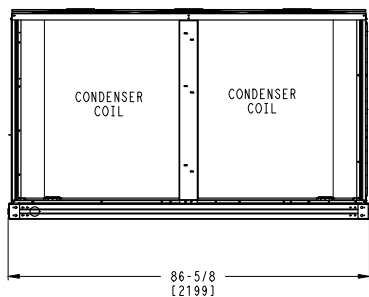

Optional Economizer Hood

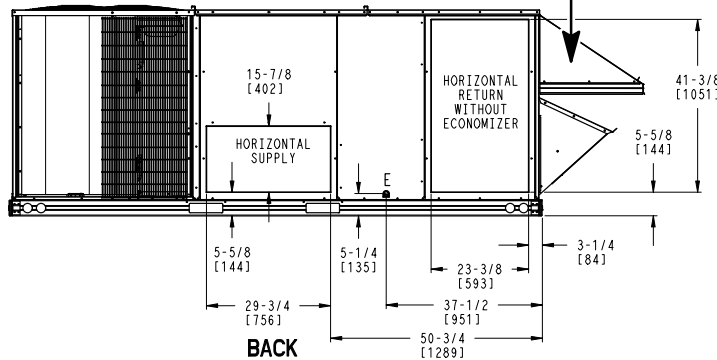

(HORIZONTAL DISCHARGE W/O ECON)
(WHEN ORDERED)

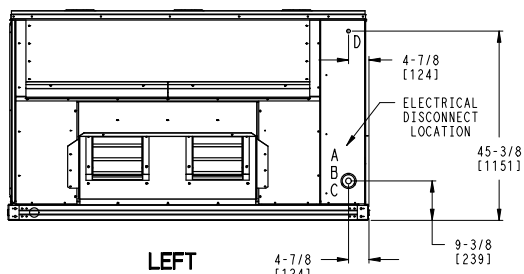

WEIGHT & DIMENSIONS – RAS210/213 (cont.)

UNIT RAS	MAX UNIT WEIGHT		Corner Weight A		Corner Weight B		Corner Weight C		Corner Weight D		Center of Gravity In [mm]		
	LBS	KG	LBS	KG	LBS	KG	LBS	KG	LBS	KG	X	Y	Z
17.5 Ton	2243	1017	419	190	496	225	493	224	415	188	42-7/8 [1090]	69-1/4 [1759]	16-1/2 [419]

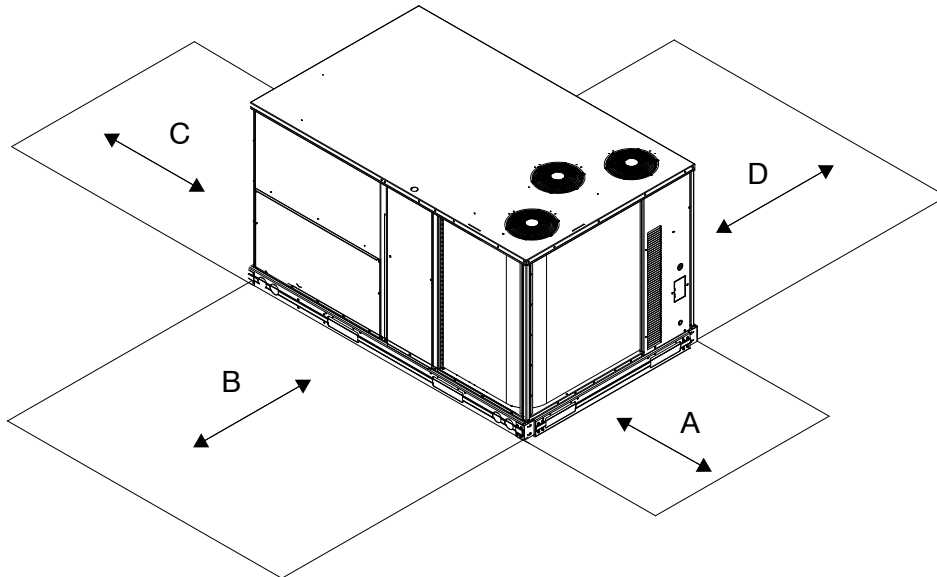
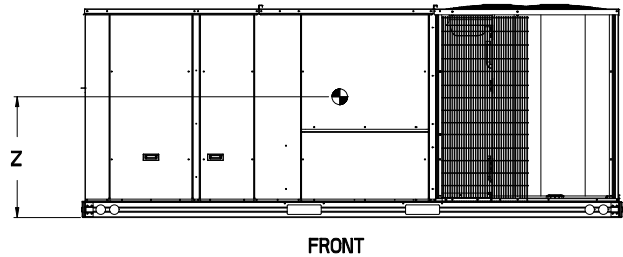
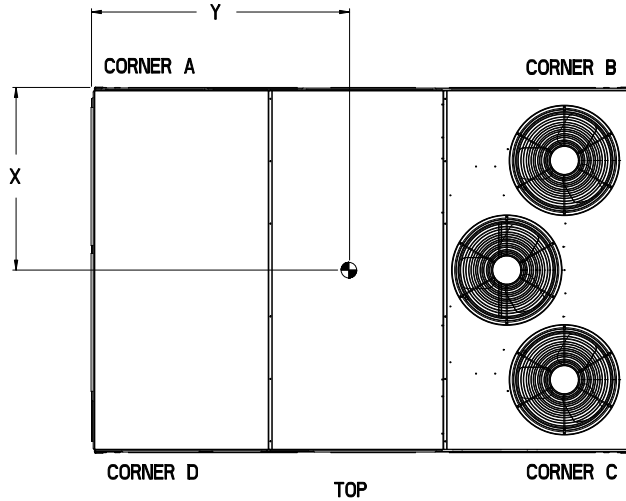

LOC	DIMENSION	CONDITION
A	36 in. (914 mm)	Recommended clearance for airflow and service.
B	42 in. (1067 mm)	Recommended clearance for airflow and service.
C	18 in. (457 mm)	1. No CO. 2. No Economizer. 3. No field installed disconnect on economizer hood side. (Factory installed disconnect installed.)
	36 in. (914 mm)	1. CO installed. 2. Vertical surface behind servicer is electrically non-conductive (e.g. Wood, fiberglass).
	42 in. (1067 mm)	1. CO installed. 2. Vertical surface behind servicer is electrically conductive (e.g. Metal, masonry)
	96 in. (2438 mm)	1. Economizer and/or Power Exhaust installed.
D	42 in. (1067 mm)	Recommended clearance for airflow and service.

NOTE: Unit not designed to have overhead obstruction. Contact Application Engineering for guidance on any application planning overhead obstruction or for vertical clearances.

ROOF CURB DETAILS – RAS210/213

RoofCurb Accessory	A	Unit Size
CRRFCURB045A01	1' 2" [356]	RAS210/213
CRRFCURB046A01	2' 0" [610]	

- NOTES:
1. Roofcurb accessory is shipped disassembled.
 2. Dimensions in. [] in millimeters.
 3. Roofcurb galvanized steel.
 4. Attach ductwork to curb (Flanges of duct rest on curb)
 5. Service clearance 4' on each side.
- ➡ Direction of airflow.

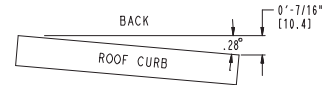
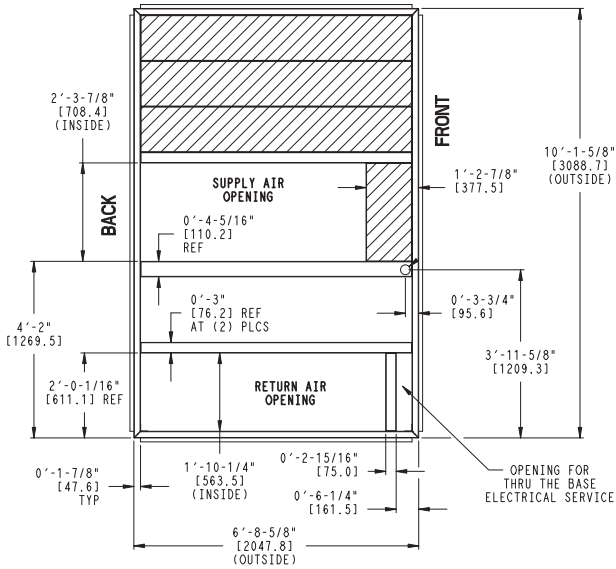

MAX CURB LEVELING TOLERANCES

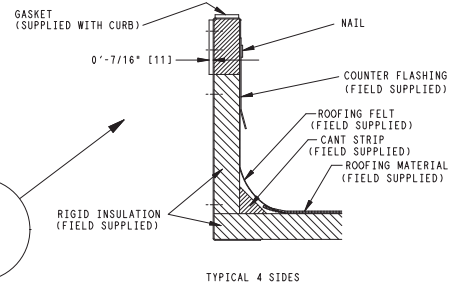
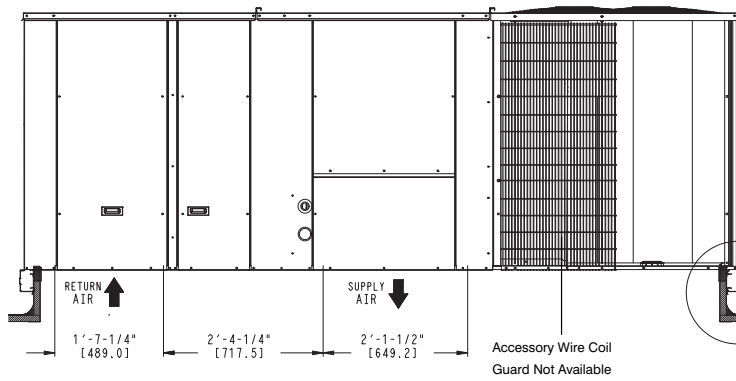

TYPICAL 4 SIDES

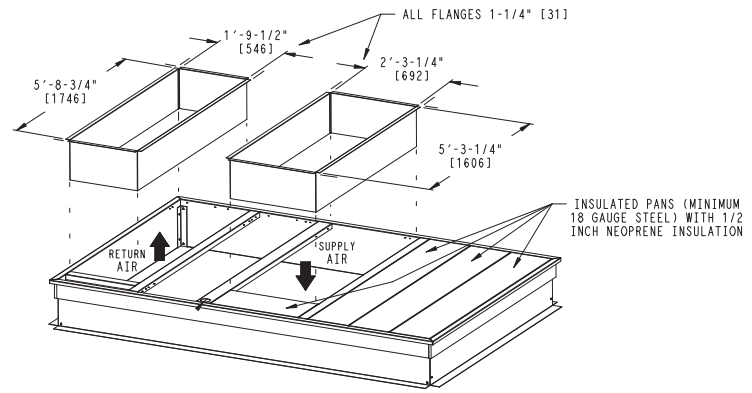
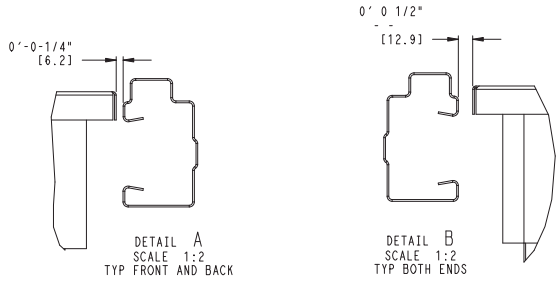
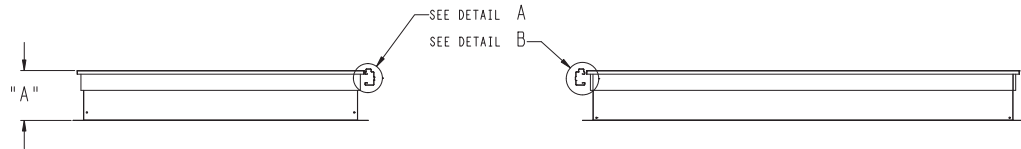

BASE UNIT DIMENSIONS - RAS240/243 - 300/303

CONNECTION SIZES	
A	1 3/8" DIA [35] FIELD POWER SUPPLY KNOCKOUT
B	3" DIA [76] FIELD POWER SUPPLY KNOCKOUT
C	3 5/8" DIA [92] FIELD POWER SUPPLY KNOCKOUT
D	7/8" DIA [22] FIELD CONTROL WIRING HOLE
E	3/4"-14 NPT CONDENSATE DRAIN

UNIT	G	H
240/243	41-3/8 [1051]	49-3/8 [1253]
300/303	49-3/8 [1253]	57-3/8 [1456]

NOTES:

1. DIMENSIONS ARE IN INCHES, DIMENSIONS IN [] ARE IN MILLIMETERS.
2. CENTER OF GRAVITY
3. DIRECTION OF AIR FLOW

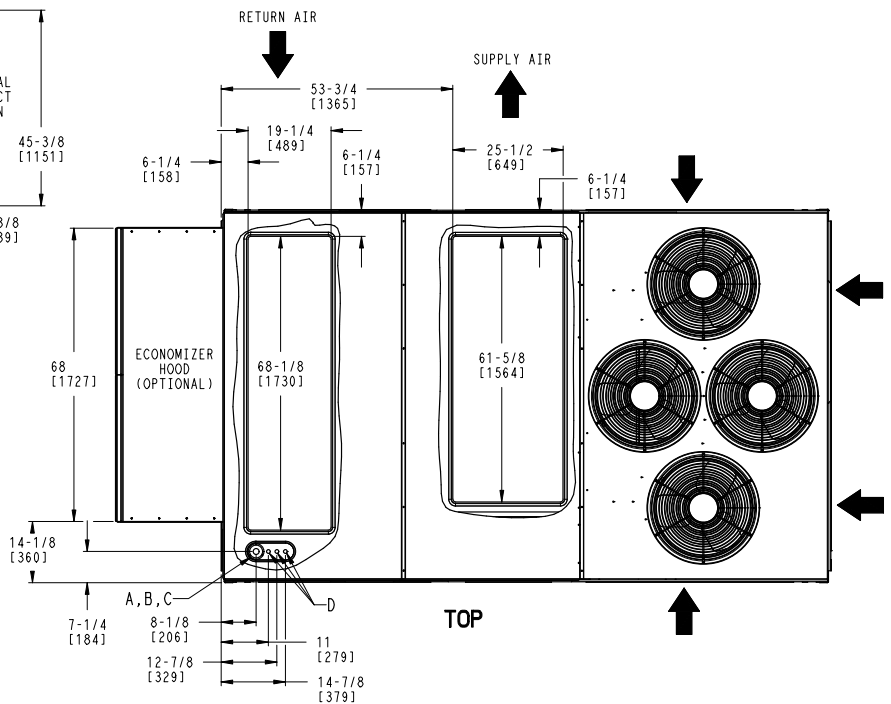
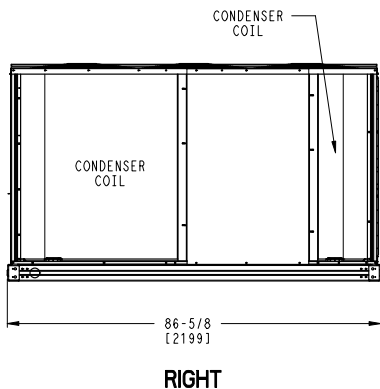
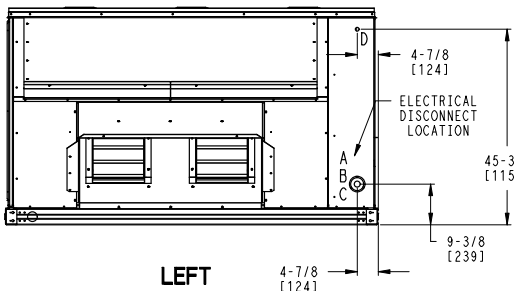
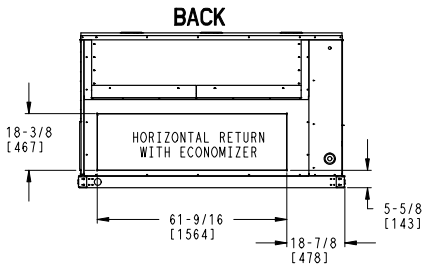
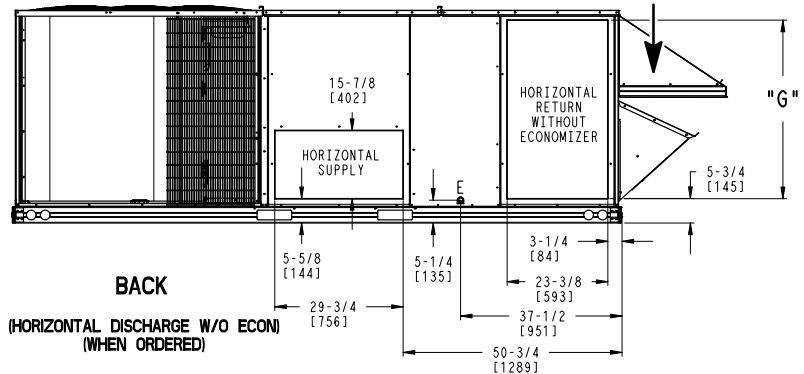
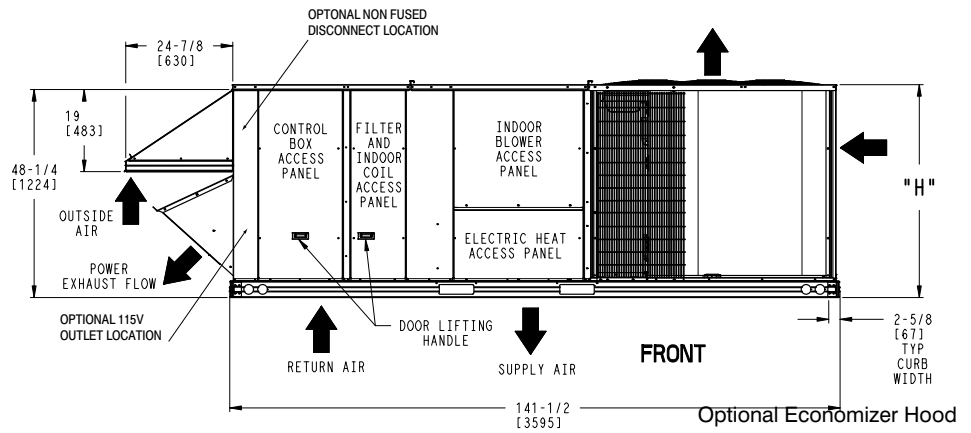

WEIGHT & CLEARANCE DIMENSIONS – RAS240/243–300/303 (cont.)

UNIT	Max Unit Weight		Corner Weight (A)		Corner Weight (B)		Corner Weight (C)		Corner Weight (D)		Center of Gravity In [mm]		
	Lb	Kg	Lb	Kg	Lb	Kg	Lb	Kg	Lb	Kg	X	Y	Z
20 Ton	2277	1033	532	241	522	237	456	207	464	210	40-1/8 [1020]	70 [1778]	16-1/2 [419]
25 Ton	2525	1145	545	247	539	245	504	229	510	231	41-5/8 [1058]	70-1/4 [1784]	19 [483]

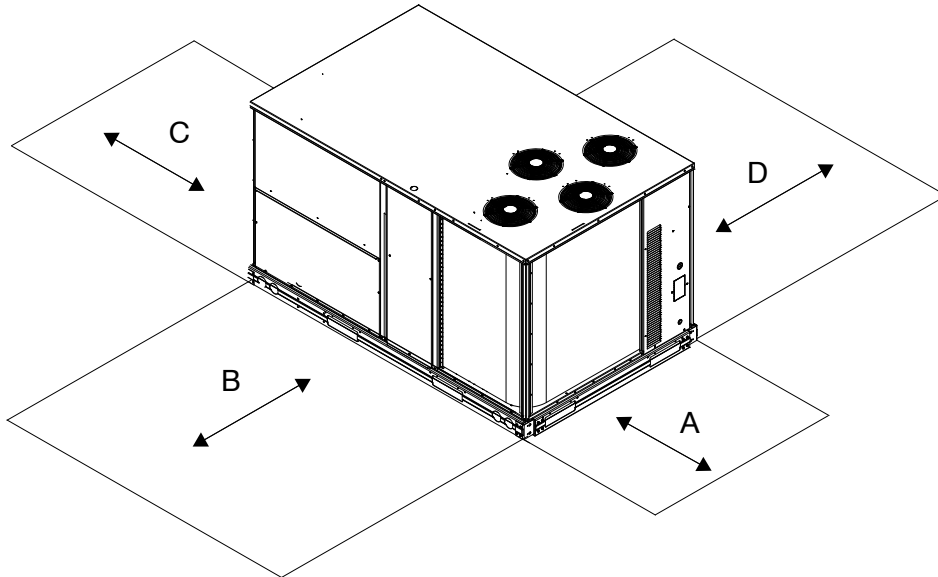
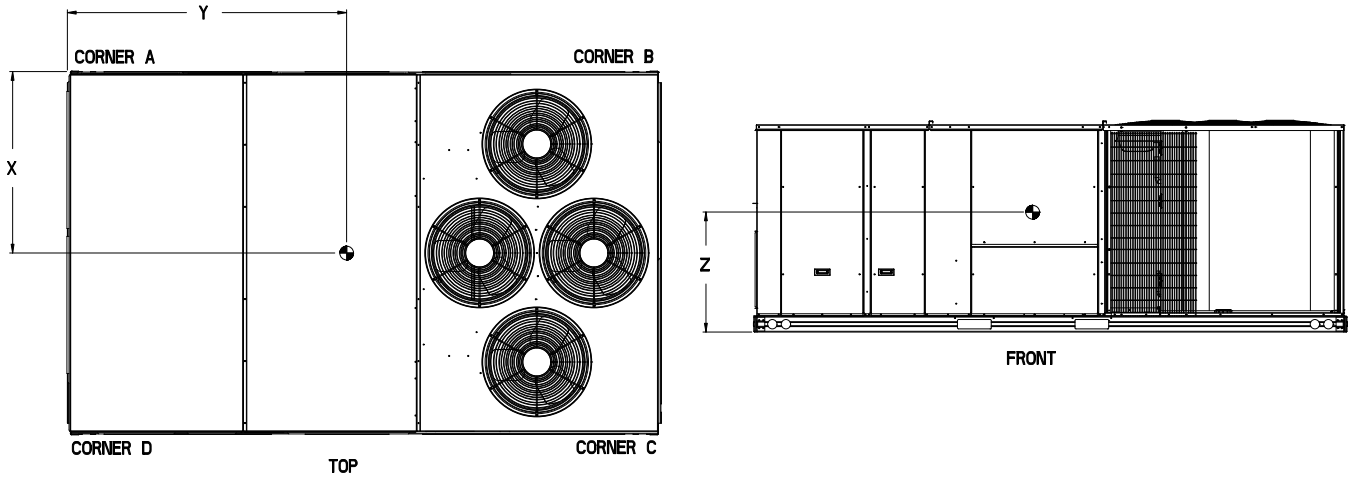

LOC	DIMENSION	CONDITION
A	36 in. (914 mm)	Recommended clearance for airflow and service.
B	42 in. (1067 mm)	Recommended clearance for airflow and service.
C	18 in. (457 mm)	1. No CO. 2. No Economizer. 3. No field installed disconnect on economizer hood side. (Factory installed disconnect installed.)
	36 in. (914 mm)	1. CO installed. 2. Vertical surface behind servicer is electrically non-conductive (e.g. Wood, fiberglass).
	42 in. (1067 mm)	1. CO installed. 2. Vertical surface behind servicer is electrically conductive (e.g. Metal, masonry)
	96 in. (2438 mm)	1. Economizer and/or Power Exhaust installed.
D	42 in. (1067 mm)	Recommended clearance for airflow and service.

NOTE: Unit not designed to have overhead obstruction. Contact Application Engineering for guidance on any application planning overhead obstruction or for vertical clearances.

ROOF CURB DETAILS – RAS240/243 – 300/303

RoofCurb Accessory	A	Unit Size
CRRFCURB047A01	1' 2" [356]	RAS240/243
CRRFCURB048A01	2' 0" [610]	RAS300/303

- NOTES:
1. Roofcurb accessory is shipped disassembled.
 2. Dimensions in. [] in millimeters.
 3. Roofcurb galvanized steel.
 4. Attach ductwork to curb (Flanges of duct rest on curb)
 5. Service clearance 4' on each side.
- ➡ Direction of airflow.

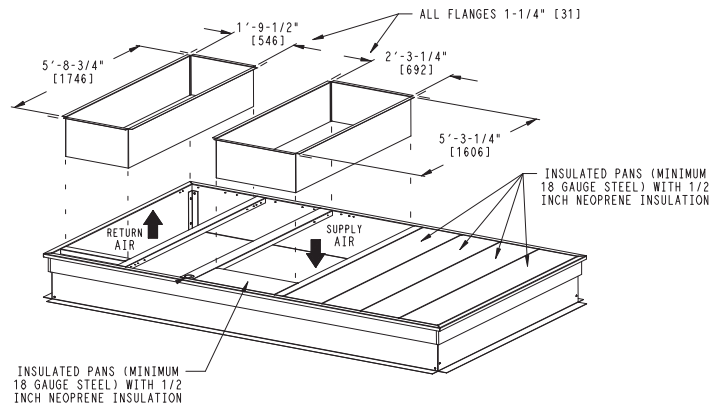
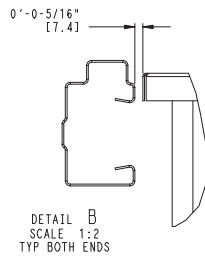
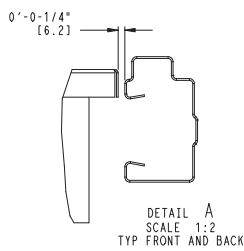
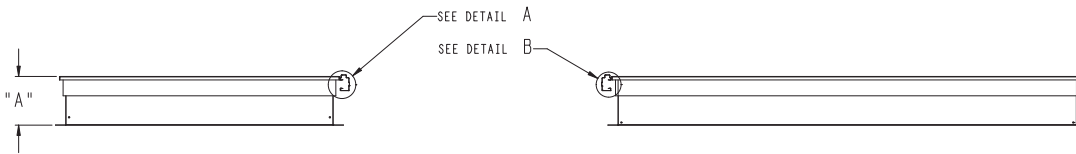
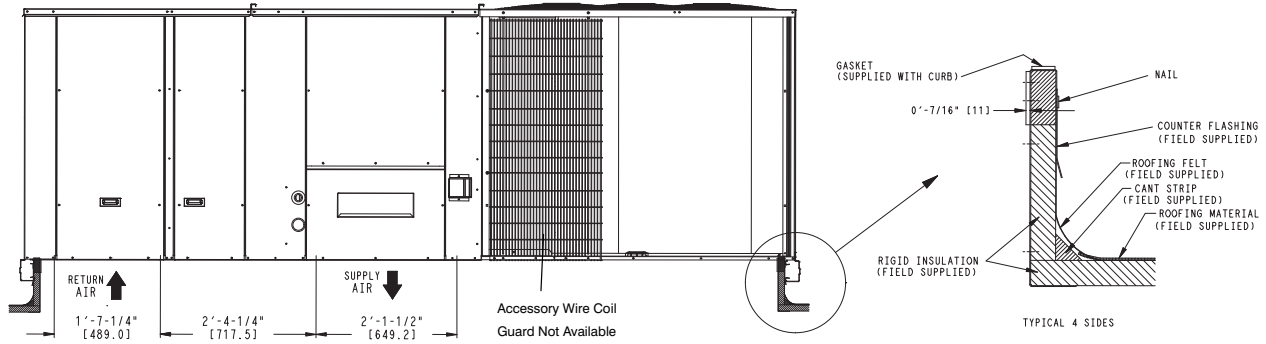
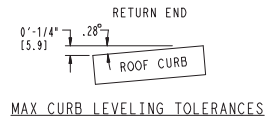
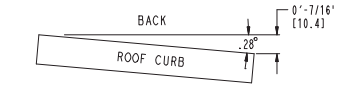
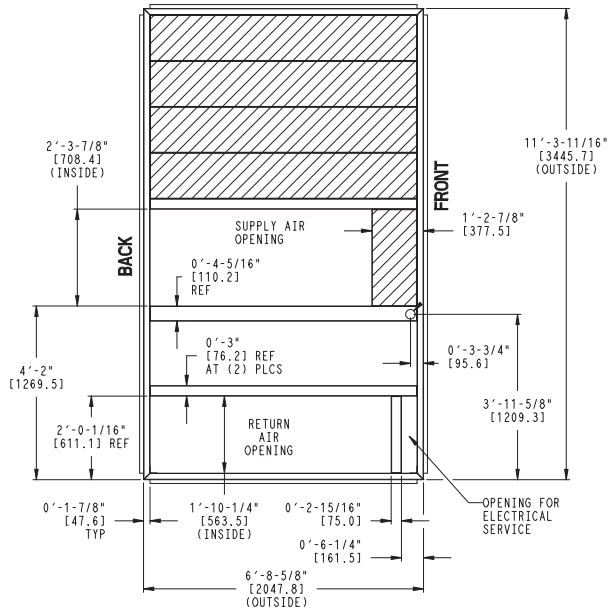

BASE UNIT DIMENSIONS – RAS336/333

NOTES:

1. DIMENSIONS ARE IN INCHES, DIMENSIONS IN [] ARE IN MILLIMETERS.
2. CENTER OF GRAVITY
3. DIRECTION OF AIR FLOW

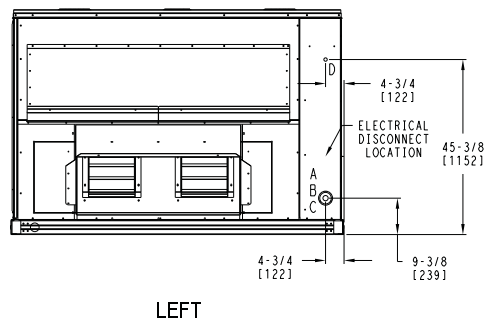
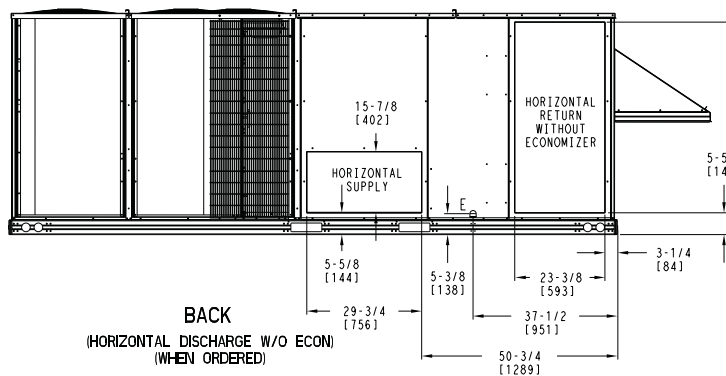
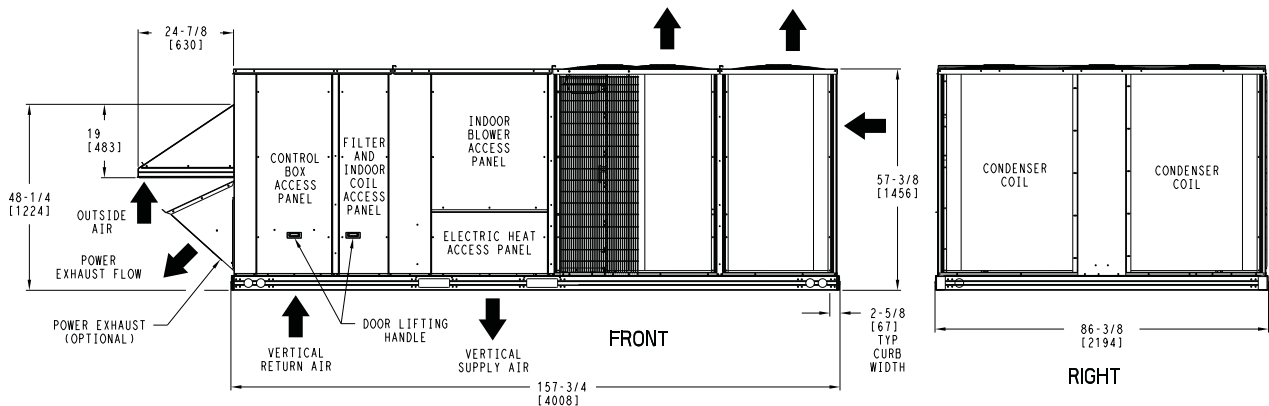
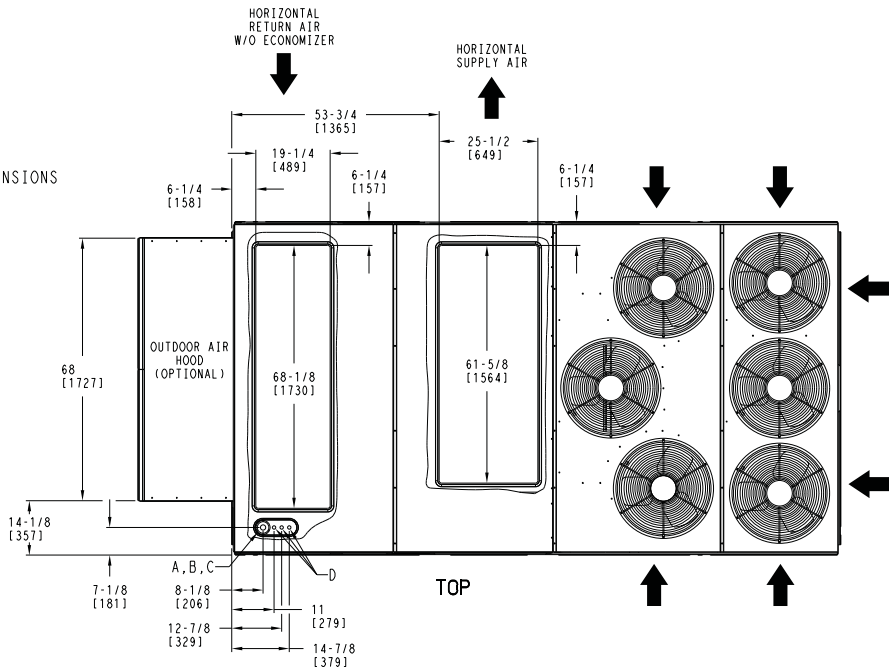

CONNECTION SIZES	
A	1 3/8" DIA [35] FIELD POWER SUPPLY KNOCKOUT
B	3" DIA [76] FIELD POWER SUPPLY KNOCKOUT
C	3 5/8" DIA [92] FIELD POWER SUPPLY KNOCKOUT
D	7/8" DIA [22] FIELD CONTROL WIRING HOLE
E	3/4"-14 NPT CONDENSATE DRAIN

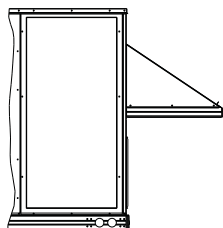

BACK
(HORIZONTAL DISCHARGE W/ ECON)
(WHEN ORDERED)

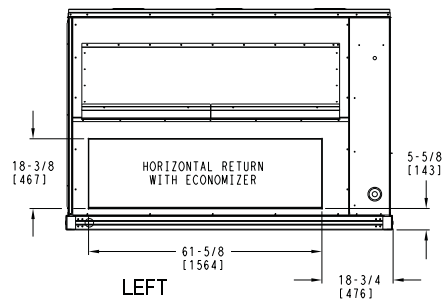

WEIGHT & CLEARANCE DIMENSIONS – RAS336/333 (cont.)

UNIT	Max Unit Weight		Corner Weight (A)		Corner Weight (B)		Corner Weight (C)		Corner Weight (D)		Center of Gravity In [mm]		
	Lb	Kg	Lb	Kg	Lb	Kg	Lb	Kg	Lb	Kg	X	Y	Z
30 Ton	2513	1142	664	302	566	257	591	269	693	315	44 [1118]	72-1/2 [1842]	19 [483]

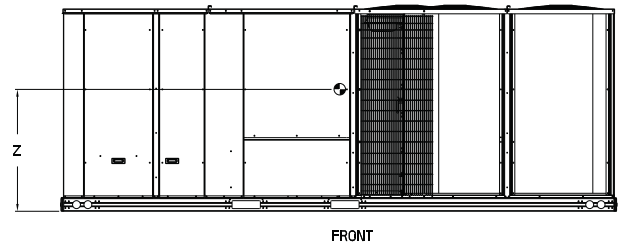
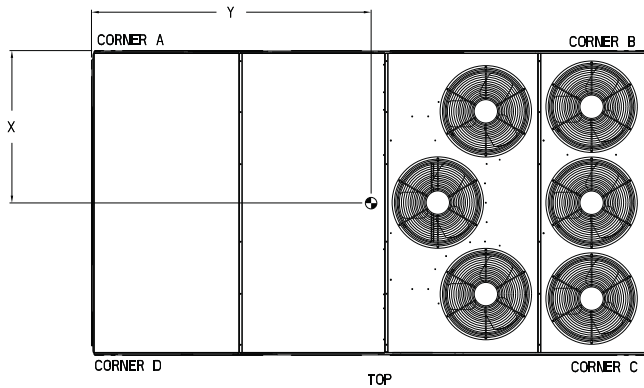

C11230A

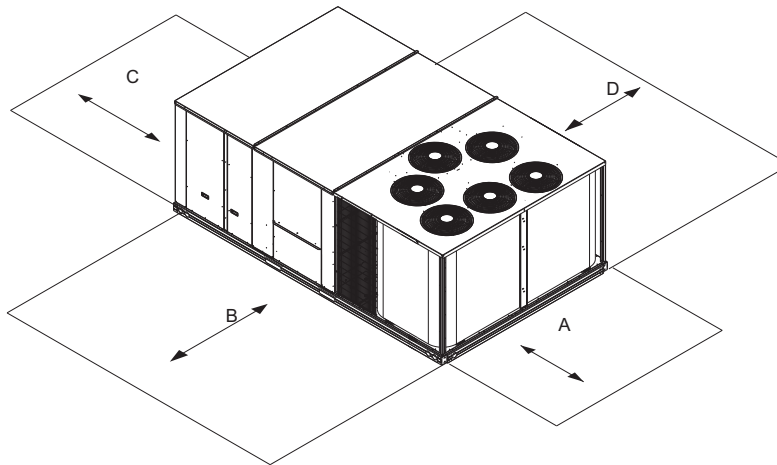

C11344

LOC DIMENSION

CONDITION

LOC	DIMENSION	CONDITION
A	36 in. (914 mm)	Recommended clearance for airflow and service.
B	42 in. (1067 mm)	Recommended clearance for airflow and service.
C	18 in. (457 mm)	1. No CO. 2. No Economizer. 3. No field installed disconnect on economizer hood side. (Factory installed disconnect installed.)
	36 in. (914 mm)	1. CO installed. 2. Vertical surface behind servicer is electrically non-conductive (e.g. Wood, fiberglass).
	42 in. (1067 mm)	1. CO installed. 2. Vertical surface behind servicer is electrically conductive (e.g. Metal, masonry)
	96 in. (2438 mm)	1. Economizer and/or Power Exhaust installed.
D	42 in. (1067 mm)	Recommended clearance for airflow and service.

NOTE: Unit not designed to have overhead obstruction. Contact Application Engineering for guidance on any application planning overhead obstruction or for vertical clearances.

ROOF CURB DETAILS – RAS336/333

UNIT SIZE	"A"	ROOF CURB ACCESSORY
30	1'-2" [356.0] 2'-0" [610.0]	CRRFCURB049A00 CRRFCURB050A00

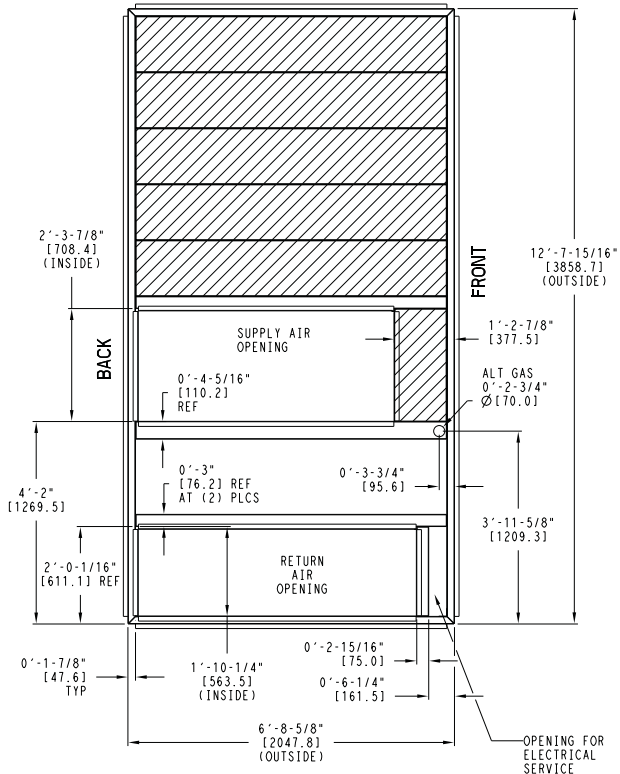

- NOTES:
- 1 ROOF CURB ACCESSORY IS SHIPPED UNASSEMBLED.
 - 2 BOLT HEADS TO BE ON INSIDE OF FLANGE. CLEARANCE IS (11) 0'-0-7/16" TYP ALL CORNERS.
 - 3 DIMENSIONS IN () ARE IN MILLIMETERS.
 - 4 ROOF CURB GALVANIZED STEEL.
 - 5 ATTACH DUCTWORK TO CURB (FLANGES ON DUCT REST ON CURB)
 - 6 SERVICE CLEARANCE 4 ft ON EACH SIDE
- ➔ DIRECTION OF AIR FLOW

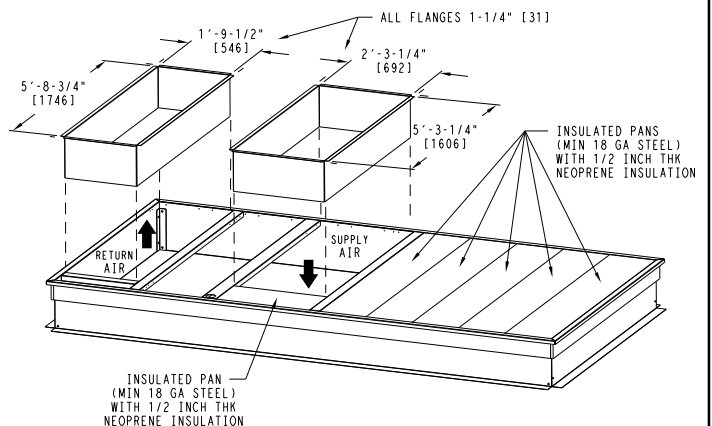
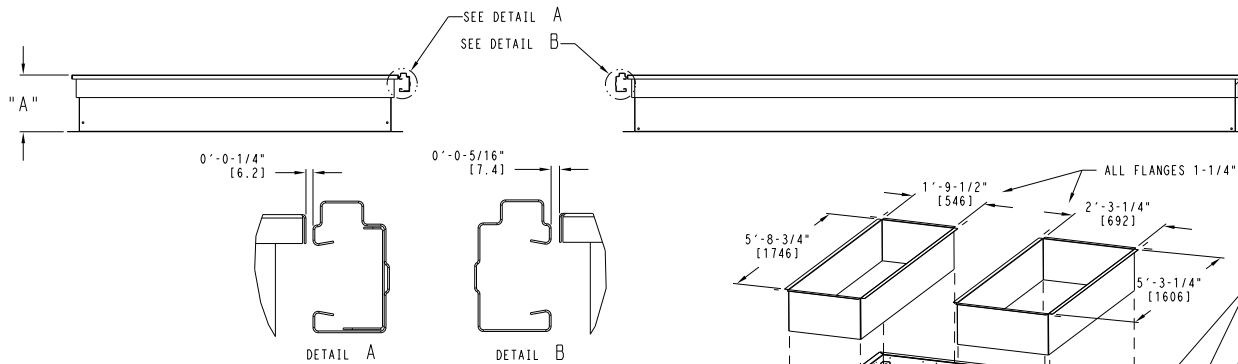
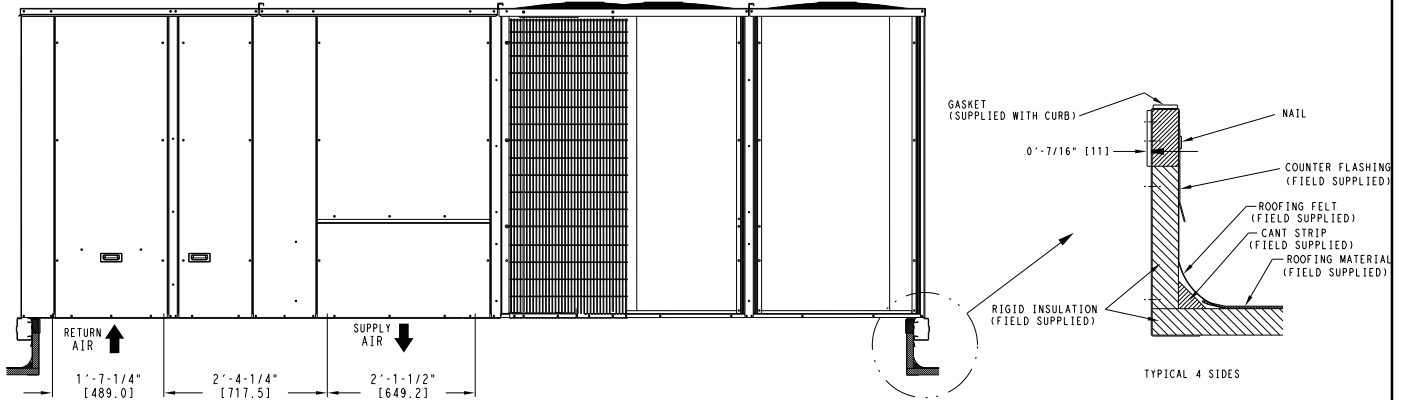
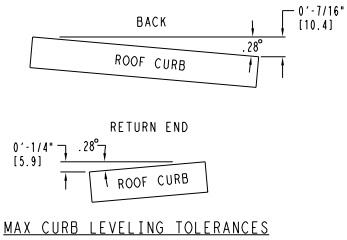

OPTIONS AND ACCESSORIES WEIGHT ADDERS

BASE UNIT WITH OPTIONS AND ACCESSORIES (Weight Adders)	MAX WEIGHT ADDER							
	RAS210/213		RAS240/243		RAS300/303		RAS336/333	
	lb	kg	lb	kg	lb	kg	lb	kg
Hot Gas Reheat ¹	83	38	83	38	92	42	n/a	n/a
Base Unit Operating Weight	1922	872	2072	940	2197	997	2640	1197
Power Exhaust	125	57	125	57	125	57	125	57
EconoMi\$er (IV, or X)	170	77	170	77	195	88	195	88
Copper Tube/Fin Evaporator Coil	110	50	135	61	161	73	173	78
Roof Curb 14-in (356mm)	240	109	240	109	240	109	255	116
Roof Curb 24-in (610mm)	340	154	340	154	340	154	355	161
Louvered Hail Guard	60	27	120	54	135	61	150	68
CO ₂ sensor	5	2	5	2	5	2	5	2
Supply Smoke Detector	5	2	5	2	5	2	5	2
Fan/Filter Status Switch	2	1	2	1	2	1	2	1
Non-Fused Disconnect	15	7	15	7	15	7	15	7
Non-Powered Convenience Outlet	5	2	5	2	5	2	5	2
Enthalpy Sensor	2	1	2	1	2	1	2	1
Differential Enthalpy Sensor	3	1	3	1	3	1	3	1
Two Position Motorized Damper	50	23	50	23	65	29	65	29
Manual Damper	35	16	35	16	40	18	40	18
Field Filter Track 4-in (102mm)	12	5	12	5	12	5	12	5
MotorMaster Controller	35	16	35	16	35	16	35	16
Medium Static Motor/Drive	6	3	6	3	6	3	10	5
High Static Motor/Drive	12	5	16	7	16	7	20	9
Barometric Relief Hood (Horizontal)	25	11	25	11	25	11	25	11
2-Speed Indoor Fan Motor System w/VFD	20	9	20	9	20	9	20	9

¹ Hot Gas Reheat add MotorMaster Controller.

APPLICATION DATA

Min operating ambient temp (cooling):

In mechanical cooling mode, your rooftop unit can safely operate down to an outdoor ambient temperature of 30°F (-1°C). It is possible to provide cooling at lower outdoor ambient temperatures by using less outside air, economizers, and/or accessory low ambient kits.

Max operating ambient temp (cooling):

The maximum operating ambient temperature for cooling mode is 115°F (46°C). While cooling operation above 115°F (46°C) may be possible, it could cause either a reduction in performance, reliability, or a protective action by the unit's internal safety devices.

Min and max airflow (cooling):

To maintain safe and reliable operation of your rooftop, operate within the cooling airflow limits. Operating above the max may cause blow-off, undesired airflow noise, or airflow related problems with the rooftop unit. Operating below the min may cause problems with coil freeze-up.

Airflow:

All units are draw-through in cooling mode.

Outdoor air application strategies:

Economizers reduce operating expenses and compressor run time by providing a free source of cooling and a means of ventilation to match application changing needs. In fact, they should be considered for most applications. Also, consider the various economizer control methods and their benefits, as well as sensors required to accomplish your application goals.

Motor limits, break horsepower (BHP):

Due to internal design of units, the air path, and specially designed motors, the full horsepower (maximum continuous BHP) band can be used with the utmost confidence. There is no need for extra safety factors, as motors are designed and rigorously tested to use the entire, listed BHP range without either nuisance tripping or premature motor failure.

Sizing a rooftop

While an air conditioner needs to have enough capacity to meet the design loads, it doesn't need excess capacity. In fact, excess capacity typically results in very poor part load performance and humidity control.

Using higher design temperatures than ASHRAE recommends for your location, adding "safety factors" to the calculated load, are all signs of oversizing air conditioners. Oversizing the air conditioner leads to poor humidity control, reduced efficiency, higher utility bills, larger indoor temperature swings, excessive noise, and increased wear and tear on the air conditioner.

Rather than oversizing an air conditioner, engineers should "right-size" or even slightly undersize air conditioners. Correctly sizing an air conditioner controls humidity better; promotes efficiency; reduces utility bills; extends equipment life, and maintains even, comfortable temperatures.

Low ambient applications

The optional economizer can adequately cool your space by bringing in fresh, cool outside air. In fact, when so equipped, accessory low-ambient kit may not be necessary. In low ambient conditions, unless the outdoor air is excessively humid or contaminated, economizer-based "free cooling" is the preferred less costly and energy conscious method.

In low ambient applications where outside air might not be desired (such as contaminated or excessively humid outdoor environments), your rooftop can operate to ambient temperatures down to -20°F (-29°C) using the recommended accessory Motormaster low ambient controller.

Winter start

The winter start kit extends the low ambient limit of your rooftop to 25°F (-4°C). The kit bypasses the low pressure switch, preventing nuisance tripping of the low pressure switch. Other low ambient precautions may still be prudent.

2-Speed Indoor Fan Motor System with Variable Frequency Drive (VFD)

The 2-Speed Indoor Fan Motor System utilizes a Variable Frequency Drive (VFD) to automatically adjust the indoor fan motor speed in sequence with the units cooling operation. Per ASHRAE 90.1 2010 standard section 6.4.3.10.b, during the first stage of cooling operation the VFD will adjust the fan motor to provide 2/3rd of the total cfm established for the unit. When a call for the second stage of cooling is required, the VFD will allow the total cfm for the unit established (100%). During the heating mode, the VFD will allow total design cfm (100%) operation and during the ventilation mode the VFD will allow operation to 2/3rd of total cfm.

The VFD used in the 2-Speed Indoor Fan Motor System has soft start capabilities to slowly ramp up the speeds, thus eliminating any high inrush air volume during initial start-up. It also has internal over current protection for the fan motor and a field installed display kit that allows adjustment and in depth diagnostics of the VFD.

This 2-Speed Indoor Fan Motor System is available on models with 2-stage cooling operation with electrical mechanical controls. Both space sensor and conventional thermostats/controls can be used to provide accurate control in any application.

The 2-Speed Indoor Fan Motor System is very flexible for initial fan performance set up and adjustment. The standard factory shipped VFD is pre programmed to automatically stage the fan speed between the first and second stage of cooling. The unit fan performance static pressure and cfm can be easily adjusted using the traditional means of pulley adjustments. The other means to adjust the unit static and cfm performance is to utilize the field installed display module and adjust the frequency and voltage in the VFD to required performance requirements. In either case, once set up the VFD will automatically adjust the speed between the cooling stage operation.

Table 7 – COOLING CAPACITIES 17.5 TONS (2 Stage Cooling)

RAS210/213			AMBIENT TEMPERATURE												
			85			95			105			115			
			EAT (DB)			EAT (DB)			EAT (DB)			EAT (DB)			
			75	80	85	75	80	85	75	80	85	75	80	85	
5250 Cfm	EAT (wb)	58	THC	180.4	185.6	196.3	167.7	176.1	186.9	154.7	165.3	176.6	142.2	153.6	164.9
		SHC	166.5	185.6	196.3	160.6	176.1	186.9	152.7	165.3	176.6	142.2	153.6	164.9	
		62	THC	196.2	195.5	196.9	183.6	182.9	187.2	169.3	168.7	176.9	153.4	154.1	165.2
		SHC	146.8	172.1	194.7	141.4	166.6	187.2	135.4	160.5	176.9	128.6	152.5	165.2	
		67	THC	216.7	215.9	215.2	204.9	204.1	203.1	190.6	189.7	189.0	174.8	174.0	173.3
	SHC	120.0	146.1	171.8	115.4	141.5	167.1	109.8	136.1	161.7	103.8	130.2	155.6		
	72	THC	237.4	236.8	236.0	226.0	225.1	224.2	212.8	211.9	211.0	197.3	196.4	195.5	
	SHC	92.0	118.3	144.3	87.8	114.3	140.4	83.0	109.6	135.8	77.6	104.2	130.6		
	76	THC	—	252.9	253.0	—	242.5	241.6	—	229.1	228.2	—	214.1	213.1	
	SHC	—	95.1	121.4	—	91.7	118.0	—	87.3	113.8	—	82.5	107.1		
6125 Cfm	EAT (wb)	58	THC	188.8	198.5	209.3	176.5	188.2	200.2	164.5	176.7	189.0	151.9	164.2	176.7
		SHC	180.4	198.5	209.3	174.4	188.2	200.2	164.5	176.7	189.0	151.9	164.2	176.7	
		62	THC	205.2	204.6	209.6	191.8	191.5	200.4	176.6	177.6	189.2	159.9	164.2	176.9
		SHC	159.9	188.7	209.6	154.2	183.0	200.4	147.9	174.8	189.2	141.0	164.2	176.9	
		67	THC	225.5	224.5	223.5	213.5	212.5	211.7	199.1	198.3	197.4	182.3	181.4	180.9
	SHC	128.3	158.4	187.8	123.8	154.1	183.5	118.4	148.9	178.1	112.2	142.7	171.6		
	72	THC	245.6	245.3	244.6	234.7	233.6	232.6	220.9	219.9	218.8	205.5	204.4	203.4	
	SHC	95.4	125.9	155.7	91.7	122.2	152.4	86.9	117.7	148.1	81.7	112.5	143.1		
	76	THC	—	262.0	261.2	—	250.7	250.1	—	237.3	236.2	—	221.6	220.6	
	SHC	—	99.5	129.4	—	95.9	126.2	—	91.8	122.4	—	87.0	117.8		
7000 Cfm	EAT (wb)	58	THC	197.4	209.8	221.3	186.1	199.1	211.7	173.8	186.9	200.1	160.3	173.5	186.9
		SHC	196.8	209.8	221.3	186.1	199.1	211.7	173.8	186.9	200.1	160.3	173.5	186.9	
		62	THC	212.7	212.4	221.5	198.4	199.8	212.0	182.3	186.9	200.3	164.7	173.8	187.1
		SHC	173.4	205.1	221.5	167.4	197.4	212.0	160.8	186.8	200.3	153.4	173.8	187.1	
		67	THC	233.7	232.5	231.4	220.8	219.8	218.9	205.6	204.5	204.1	187.8	186.8	188.0
	SHC	138.0	172.0	205.0	133.4	167.6	200.4	127.8	162.0	194.4	121.3	155.6	185.6		
	72	THC	254.3	253.3	252.8	242.7	241.5	240.3	228.0	226.8	225.7	211.8	210.6	209.3	
	SHC	101.3	135.4	169.2	97.3	131.8	165.9	92.3	127.2	161.5	86.9	121.8	156.3		
	76	THC	—	270.7	269.9	—	259.0	258.1	—	245.0	243.6	—	228.5	227.1	
	SHC	—	106.1	140.0	—	102.4	136.5	—	98.2	132.7	—	93.2	127.9		
7875 Cfm	EAT (wb)	58	THC	205.0	217.2	229.1	193.4	206.9	219.3	180.6	194.3	207.9	166.6	180.5	194.5
		SHC	205.0	217.2	229.1	193.4	206.9	219.3	180.6	194.3	207.9	166.6	180.5	194.5	
		62	THC	216.7	217.4	229.4	202.5	207.1	219.6	185.9	194.5	208.4	168.4	180.7	194.7
		SHC	183.9	217.4	229.4	178.2	207.1	219.6	171.5	194.5	208.4	141.2	180.7	194.7	
		67	THC	237.8	236.7	235.7	224.7	223.5	223.0	209.5	208.3	209.2	191.5	190.3	195.0
	SHC	144.6	182.4	219.3	140.3	178.2	213.7	134.9	172.7	205.9	113.6	166.2	195.0		
	72	THC	258.6	257.5	256.5	246.8	245.7	244.3	231.8	230.5	229.2	215.3	213.9	212.5	
	SHC	103.9	141.8	179.2	100.0	138.3	176.1	95.1	133.9	172.1	89.7	128.6	142.0		
	76	THC	—	275.4	274.2	—	262.7	261.8	—	248.7	247.6	—	231.9	230.5	
	SHC	—	109.5	147.0	—	105.7	143.6	—	101.5	139.9	—	96.6	135.4		
8750 Cfm	EAT (wb)	58	THC	211.3	223.6	235.9	199.7	213.4	225.7	186.4	200.7	214.3	172.1	186.5	200.9
		SHC	211.3	223.6	235.9	199.7	213.4	225.7	186.4	200.7	214.3	172.1	186.5	200.9	
		62	THC	220.0	223.7	236.3	206.0	213.6	226.1	189.3	200.9	214.5	172.2	186.7	201.2
		SHC	194.0	223.7	236.3	188.5	213.6	226.1	181.3	200.9	214.5	172.2	186.7	201.2	
		67	THC	241.1	240.1	239.7	227.9	226.6	226.9	212.7	211.4	214.9	194.4	193.0	201.4
	SHC	151.0	192.1	230.2	146.9	188.3	225.2	141.6	182.9	214.8	135.3	176.3	201.4		
	72	THC	262.2	261.0	259.7	250.0	248.8	247.7	235.0	233.5	232.1	218.1	216.6	215.2	
	SHC	106.5	148.1	189.0	102.5	144.5	186.0	97.8	140.4	182.1	92.4	135.3	177.1		
	76	THC	—	278.9	277.4	—	266.0	264.8	—	251.5	250.6	—	234.7	233.0	
	SHC	—	112.7	153.7	—	108.9	150.4	—	104.7	146.7	—	100.0	142.4		

LEGEND:

- Do not operate
- Cfm — Cubic feet per minute (supply air)
- EAT(db) — Entering air temperature (dry bulb)
- EAT(wb) — Entering air temperature (wet bulb)
- SHC — Sensible heat capacity
- TC — Total capacity

Table 8 – COOLING CAPACITIES 17.5 TONS (2 Stage Cooling)

RAS210/213 (17.5 TONS) – UNIT WITH HOT GAS REHEAT IN SUBCOOLING MODE										
Temp (F) Air Ent Condenser (Edb)		AIR ENTERING EVAPORATOR – CFM								
		5,250			7,000			8,750		
		Air Entering Evaporator – Ewb (F)								
		72	67	62	72	67	62	72	67	62
75	TC	218.7	199.6	180.5	241.4	219.4	197.4	261.7	237.2	212.7
	SHC	99.9	123.9	147.8	112.7	136.9	161.1	122.9	147.3	171.7
	kW	11.81	11.56	11.20	13.81	13.48	13.16	14.82	14.58	14.16
85	TC	206.6	187.9	169.1	224.9	203.4	181.9	241.3	217.3	193.4
	SHC	78.9	108.4	137.9	92.2	122.1	152.0	103.0	133.1	163.3
	kW	13.18	12.53	12.53	15.18	14.85	14.52	16.21	15.85	15.54
95	TC	194.7	176.2	157.8	208.4	187.4	166.4	220.8	197.4	174.1
	SHC	57.8	92.9	128.0	71.7	107.3	142.9	83.0	118.9	154.9
	kW	14.56	14.21	13.88	16.56	16.21	15.87	17.56	17.22	16.01
105	TC	182.7	164.5	146.4	191.9	171.4	150.8	200.3	177.6	154.8
	SHC	36.8	77.4	118.1	51.3	92.5	133.8	63.0	104.7	146.4
	kW	15.93	15.58	15.20	17.94	17.58	17.22	18.95	18.59	18.24
115	TC	170.6	152.8	135.0	175.4	155.4	135.3	179.8	157.7	135.5
	SHC	15.7	62.0	108.2	30.8	77.8	124.7	43.0	90.5	128.0
	kW	17.31	16.95	16.58	19.32	18.95	18.58	20.32	19.96	19.59

RAS210/213 (17.5 TONS) – UNIT WITH HOT GAS REHEAT IN HOT GAS REHEAT MODE										
Temp (F) Air Ent Condenser (Edb)		AIR ENTERING EVAPORATOR – Ewb (F)								
		75 Dry Bulb			75 Dry Bulb			75 Dry Bulb		
		62.5 Wet Bulb			64 Wet Bulb			65.3 Wet Bulb		
		(50% Relative)			(56% Relative)			(60% Relative)		
		Air Entering Evaporator – Cfm								
		5,250	7,000	8,750	5,250	7,000	8,750	5,250	7,000	8,750
80	TC	82.20	90.50	92.40	86.70	96.40	97.80	91.60	99.80	101.20
	SHC	18.20	29.40	41.60	8.60	17.20	27.50	0.50	9.30	13.20
	kW	12.64	12.73	12.88	12.78	13.06	13.15	12.96	13.07	13.22
75	TC	84.40	92.70	94.40	88.80	98.60	99.70	93.70	102.00	103.40
	SHC	19.70	31.30	43.50	10.10	18.80	29.20	12.10	10.80	15.30
	kW	12.60	12.71	12.85	12.75	13.02	13.12	12.93	13.03	13.19
70	TC	86.70	94.90	96.60	91.00	100.70	102.00	95.90	104.10	105.40
	SHC	21.30	32.80	44.80	11.60	20.40	30.70	3.80	12.30	16.50
	kW	12.56	12.66	12.82	12.70	12.99	13.08	12.89	13.00	13.14
60	TC	90.90	99.10	100.80	95.20	105.00	106.30	100.20	108.30	109.70
	SHC	24.80	36.00	48.20	14.90	23.90	35.90	7.20	15.60	19.60
	kW	12.49	12.60	12.75	12.64	12.92	13.02	12.83	12.93	13.09
50	TC	95.00	103.40	105.10	99.50	109.40	110.50	104.40	112.50	113.90
	SHC	28.10	39.30	51.30	18.20	27.20	37.40	10.30	18.90	23.20
	kW	12.43	12.53	12.67	12.57	12.86	12.95	12.76	12.87	13.02
40	TC	99.20	107.70	109.30	103.70	113.70	114.70	108.60	116.70	118.10
	SHC	31.40	42.50	54.40	21.30	30.40	40.50	13.40	22.00	26.50
	kW	12.35	12.45	12.61	12.50	12.79	12.87	12.68	12.80	12.94

LEGEND

- Edb – Entering Dry–Bulb
- Ewb – Entering Wet–Bulb
- kW – Compressor Motor Power Input
- ldb – Leaving Dry–Bulb
- lwb – Leaving Wet–Bulb
- SHC – Sensible Heat Capacity (1000 Btuh) Gross
- TC – Total Capacity (1000 Btuh) Gross

NOTES:

1. Direct interpolation is permissible. Do not extrapolate.
1. The following formulas may be used:

$$t_{ldb} = t_{edb} - \frac{\text{sensible capacity (Btuh)}}{1.10 \times \text{cfm}}$$

t_{lwb} = Wet–bulb temperature corresponding to enthalpy of air leaving evaporator coil (h_{lwb})

$$h_{lwb} = h_{ewb} - \frac{\text{total capacity (Btuh)}}{4.5 \times \text{cfm}}$$

Where: h_{ewb} = Enthalpy of air entering evaporator coil

Table 9 – COOLING CAPACITIES 20 TONS (2 Stage Cooling)

RAS240/243				AMBIENT TEMPERATURE											
				85			95			105			115		
				EAT (DB)			EAT (DB)			EAT (DB)			EAT (DB)		
				75	80	85	75	80	85	75	80	85	75	80	85
6000 Cfm	EAT (wb)	58	THC	213.1	217.2	228.7	199.9	207.5	219.4	184.8	195.8	208.4	169.6	182.6	195.6
		SHC	194.3	217.2	228.7	188.0	207.5	219.4	179.0	195.8	208.4	169.6	182.6	195.6	
		62	THC	230.0	229.4	230.4	217.5	217.0	219.7	202.5	201.9	208.8	184.9	184.9	195.9
		SHC	170.0	199.9	225.9	164.6	194.5	219.7	158.3	187.8	208.8	150.9	178.7	195.9	
		76	THC	251.5	251.1	250.6	239.4	238.7	238.1	225.4	224.7	224.0	208.8	208.2	207.4
7000 Cfm	EAT (wb)	58	THC	220.8	229.7	241.7	208.4	219.7	232.2	194.3	208.1	221.0	180.1	194.2	207.9
		SHC	211.0	229.7	241.7	203.1	219.7	232.2	194.3	208.1	221.0	180.1	194.2	207.9	
		62	THC	237.8	237.3	241.9	225.1	224.6	232.3	209.6	210.2	221.3	191.3	196.0	208.2
		SHC	183.3	217.8	241.9	178.2	212.1	232.3	171.8	203.8	221.3	164.3	196.0	208.2	
		76	THC	260.0	259.2	258.5	247.2	246.4	245.7	232.7	231.9	231.7	215.8	215.0	214.3
8000 Cfm	EAT (wb)	58	THC	232.1	243.6	256.1	219.8	233.4	246.0	206.9	221.3	234.5	192.1	206.8	221.2
		SHC	227.5	243.6	256.1	219.8	233.4	246.0	206.9	221.3	234.5	192.1	206.8	221.2	
		62	THC	247.8	247.1	256.4	234.7	235.5	246.2	218.7	221.1	234.7	199.5	207.0	221.4
		SHC	199.5	236.7	256.4	194.3	229.1	246.2	187.8	221.1	234.7	179.9	207.0	221.4	
		76	THC	270.2	269.3	268.3	257.0	256.1	255.2	242.1	241.0	240.3	224.5	223.5	223.1
9000 Cfm	EAT (wb)	58	THC	238.5	252.5	266.0	226.8	241.6	255.6	213.1	228.2	243.0	197.5	213.0	229.2
		SHC	238.5	252.5	266.0	226.8	241.6	255.6	213.1	228.2	243.0	197.5	213.0	229.2	
		62	THC	253.0	254.1	266.3	238.6	241.6	255.7	221.0	228.4	243.3	201.1	213.2	229.4
		SHC	211.9	249.1	266.3	206.2	241.6	255.7	199.2	228.4	243.3	164.2	213.2	229.4	
		76	THC	276.9	275.8	274.8	263.0	261.8	261.0	246.5	245.2	246.6	228.2	225.9	229.6
10,000 Cfm	EAT (wb)	58	THC	245.7	259.8	273.9	233.8	248.7	263.2	219.8	235.3	250.5	203.7	219.8	236.5
		SHC	245.7	259.8	273.9	233.8	248.7	263.2	219.8	235.3	250.5	203.7	219.8	236.5	
		62	THC	256.8	260.7	274.2	242.2	249.0	263.3	224.6	235.6	250.6	205.6	220.0	236.8
		SHC	223.8	258.4	274.2	218.1	249.0	263.3	211.0	235.6	250.6	199.3	220.0	236.8	
		76	THC	280.8	279.6	266.3	266.6	265.4	265.8	249.9	248.6	251.0	231.4	229.8	237.3

- LEGEND:**
- Do not operate
 - Cfm - Cubic feet per minute (supply air)
 - EAT(db) - Entering air temperature (dry bulb)
 - EAT(wb) - Entering air temperature (wet bulb)
 - SHC - Sensible heat capacity
 - TC - Total capacity

Table 10 – COOLING CAPACITIES 20 TONS (2 Stage Cooling)

RAS240/243 (20 TONS) – UNIT WITH HOT GAS REHEAT IN SUBCOOLING MODE										
Temp (F) Air Ent Condenser (Edb)		AIR ENTERING EVAPORATOR – CFM								
		6,000			8,000			10,000		
		Air Entering Evaporator – Ewb (F)								
		72	67	62	72	67	62	72	67	62
75	TC	263.0	240.4	217.7	301.0	274.0	246.9	336.9	305.6	274.4
	SHC	125.3	151.6	178.0	144.4	171.1	198.0	160.0	186.9	213.9
	kW	15.63	15.20	14.65	15.91	15.62	14.98	16.26	15.92	15.21
85	TC	248.2	226.1	204.0	279.2	252.9	226.6	308.4	278.2	248.0
	SHC	98.9	131.7	164.5	118.6	152.0	185.3	134.6	168.4	202.2
	kW	17.50	17.04	16.50	17.74	17.51	16.75	18.08	17.73	17.03
95	TC	233.4	211.8	190.2	257.3	231.8	206.4	279.8	250.7	221.5
	SHC	72.4	111.8	151.1	92.7	132.8	172.9	109.3	149.9	190.6
	kW	19.36	18.96	18.35	19.61	19.37	18.67	20.02	19.62	18.97
105	TC	218.6	197.5	176.5	235.4	210.7	186.1	251.3	223.2	195.1
	SHC	46.0	91.8	137.7	66.9	113.6	160.4	83.9	131.4	178.9
	kW	21.23	20.76	20.18	21.53	21.22	20.52	21.91	21.52	20.77
115	TC	203.7	183.3	162.8	213.5	189.7	165.8	222.7	195.7	168.7
	SHC	19.5	71.9	124.2	41.0	94.4	147.9	58.5	112.9	157.2
	kW	23.02	22.58	22.02	23.42	23.02	22.38	23.73	23.41	22.57

RAS240/243 (20 TONS) – UNIT WITH HOT GAS REHEAT IN HOT GAS REHEAT MODE										
Temp (F) Air Ent Condenser (Edb)		AIR ENTERING EVAPORATOR – Ewb (F)								
		75 Dry Bulb			75 Dry Bulb			75 Dry Bulb		
		62.5 Wet Bulb			64 Wet Bulb			65.3 Wet Bulb		
		(50% Relative)			(56% Relative)			(60% Relative)		
		Air Entering Evaporator – Cfm								
		6,000	8,000	10,000	6,000	8,000	10,000	6,000	8,000	10,000
80	TC	91.50	100.80	109.50	95.80	105.70	112.40	102.30	110.80	118.60
	SHC	12.30	31.20	44.50	0.90	15.10	25.70	-6.50	3.60	13.90
	kW	14.82	15.01	15.24	15.35	15.45	15.52	15.56	15.65	15.73
75	TC	94.00	103.40	112.00	98.70	108.10	115.10	104.70	113.10	121.10
	SHC	13.60	32.40	45.70	2.00	16.00	26.60	-5.60	4.70	15.10
	kW	14.90	15.07	15.33	15.43	15.56	15.64	15.69	15.77	15.85
70	TC	96.50	106.00	114.30	100.90	110.60	117.20	107.20	115.80	123.50
	SHC	14.50	33.20	45.70	3.30	17.30	28.00	-4.00	5.90	16.20
	kW	14.97	15.17	15.41	15.50	15.66	15.75	15.80	15.87	15.94
60	TC	101.80	111.30	119.30	106.20	115.60	122.20	112.60	119.40	128.00
	SHC	16.70	35.50	48.60	5.60	19.40	30.30	-1.80	8.20	18.50
	kW	15.14	15.32	15.58	15.66	15.88	15.97	16.05	16.10	16.19
50	TC	107.20	116.40	124.30	111.50	120.70	127.30	117.70	125.20	132.90
	SHC	18.60	37.60	50.70	8.00	22.00	32.70	0.50	10.50	21.00
	kW	15.27	15.46	15.76	15.81	16.10	16.23	16.27	16.34	16.41
40	TC	112.20	121.80	129.20	116.60	125.70	132.00	123.20	130.00	138.00
	SHC	21.80	39.50	52.90	10.20	24.40	35.20	2.90	13.00	23.40
	kW	15.42	15.63	15.93	15.96	16.32	16.44	16.52	16.57	16.65

LEGEND

- Edb – Entering Dry–Bulb
- Ewb – Entering Wet–Bulb
- kW – Compressor Motor Power Input
- ldb – Leaving Dry–Bulb
- lwb – Leaving Wet–Bulb
- SHC – Sensible Heat Capacity (1000 Btuh) Gross
- TC – Total Capacity (1000 Btuh) Gross

NOTES:

1. Direct interpolation is permissible. Do not extrapolate.
1. The following formulas may be used:

$$t_{ldb} = t_{edb} - \frac{\text{sensible capacity (Btuh)}}{1.10 \times \text{cfm}}$$

t_{lwb} = Wet–bulb temperature corresponding to enthalpy of air leaving evaporator coil (h_{lwb})

$$h_{lwb} = h_{ewb} - \frac{\text{total capacity (Btuh)}}{4.5 \times \text{cfm}}$$

Where: h_{ewb} = Enthalpy of air entering evaporator coil

Table 12 – COOLING CAPACITIES 25 TONS (2 Stage Cooling)

RAS300/303 (25 TONS) – UNIT WITH HOT GAS REHEAT IN SUBCOOLING MODE										
Temp (F) Air Ent Condenser (Edb)		AIR ENTERING EVAPORATOR – CFM								
		7,500			10,000			12,500		
		Air Entering Evaporator – Ewb (F)								
		72	67	62	72	67	62	72	67	62
75	TC	335.3	305.5	275.8	368.3	334.4	300.5	398.1	360.5	322.9
	SHC	149.6	181.7	213.7	172.8	205.5	238.2	191.7	224.9	258.2
	kW	19.50	18.70	17.70	19.50	18.70	17.70	19.70	18.80	17.90
85	TC	316.3	287.0	257.7	341.5	308.4	275.3	364.3	327.8	291.2
	SHC	120.8	160.5	200.2	144.6	185.2	225.8	164.0	205.4	246.7
	kW	21.90	21.30	20.10	22.30	21.30	20.30	22.50	21.70	20.60
95	TC	297.3	268.5	239.6	314.7	282.4	250.1	330.5	295.0	259.5
	SHC	92.1	139.4	186.7	116.4	164.9	213.5	136.3	185.8	235.3
	kW	24.30	23.50	22.50	24.40	23.50	22.60	24.40	23.60	22.50
105	TC	278.2	249.9	221.6	287.9	256.4	224.9	296.7	262.3	227.8
	SHC	63.3	118.2	173.2	88.3	144.7	201.1	108.7	166.3	223.9
	kW	26.70	26.00	25.00	27.30	26.00	25.00	27.30	26.10	25.10
115	TC	259.2	231.4	203.5	261.1	230.4	199.7	262.9	229.5	196.1
	SHC	34.5	97.1	159.7	60.1	124.4	188.7	81.0	146.7	191.2
	kW	28.70	28.00	27.10	29.30	28.10	26.90	29.10	27.90	27.20

RAS300/303 (25 TONS) – UNIT WITH HOT GAS REHEAT IN HOT GAS REHEAT MODE										
Temp (F) Air Ent Condenser (Edb)		AIR ENTERING EVAPORATOR – Ewb (F)								
		75 Dry Bulb			75 Dry Bulb			75 Dry Bulb		
		62.5 Wet Bulb			64 Wet Bulb			65.3 Wet Bulb		
		(50% Relative)			(56% Relative)			(60% Relative)		
		Air Entering Evaporator – Cfm								
		7,500	10,000	12,500	7,500	10,000	12,500	7,500	10,000	12,500
80	TC	132.40	136.80	148.40	138.20	142.40	154.60	144.30	146.40	162.50
	SHC	37.80	61.50	85.50	21.80	44.40	52.40	16.10	32.10	48.90
	kW	17.90	18.15	18.21	18.05	18.33	18.43	18.26	18.55	18.62
75	TC	138.00	142.20	154.10	143.50	148.00	160.30	148.90	151.00	167.10
	SHC	44.20	68.00	91.80	28.10	51.50	58.80	22.70	38.20	56.00
	kW	17.77	18.00	18.07	17.92	18.19	18.29	18.14	18.40	18.48
70	TC	143.80	148.10	160.00	149.30	154.00	165.90	155.50	157.60	173.80
	SHC	50.50	73.80	98.10	34.20	56.50	65.30	28.30	44.00	62.30
	kW	17.63	17.86	17.93	17.78	18.04	18.14	18.03	18.26	18.34
60	TC	154.80	159.50	171.10	160.20	165.20	177.20	166.70	168.80	185.10
	SHC	63.10	84.50	110.10	46.50	69.50	75.70	41.40	56.50	74.30
	kW	17.35	17.58	17.65	17.50	17.76	17.85	17.70	17.97	18.04
50	TC	166.30	170.50	181.20	171.30	176.40	188.40	178.00	180.00	196.40
	SHC	75.80	96.50	122.20	58.30	79.80	87.80	53.70	69.10	85.90
	kW	17.06	17.30	17.37	17.22	17.46	17.56	17.42	17.69	17.76
40	TC	177.50	181.70	192.30	182.40	187.60	199.70	189.30	191.20	207.70
	SHC	85.70	109.80	134.30	71.50	92.30	100.50	66.10	79.50	97.90
	kW	16.76	17.01	17.09	16.93	17.18	17.28	17.14	17.41	17.47

LEGEND

- Edb – Entering Dry–Bulb
- Ewb – Entering Wet–Bulb
- kW – Compressor Motor Power Input
- ldb – Leaving Dry–Bulb
- lwb – Leaving Wet–Bulb
- SHC – Sensible Heat Capacity (1000 Btuh) Gross
- TC – Total Capacity (1000 Btuh) Gross

NOTES:

1. Direct interpolation is permissible. Do not extrapolate.
1. The following formulas may be used:

$$t_{ldb} = t_{edb} - \frac{\text{sensible capacity (Btuh)}}{1.10 \times \text{cfm}}$$

t_{lwb} = Wet–bulb temperature corresponding to enthalpy of air leaving evaporator coil (h_{lwb})

$$h_{lwb} = h_{ewb} - \frac{\text{total capacity (Btuh)}}{4.5 \times \text{cfm}}$$

Where: h_{ewb} = Enthalpy of air entering evaporator coil

Table 14 – STATIC PRESSURE ADDERS (Factory Options and/or Accessories)

Economizer – Vertical and Horizontal Duct Donfiguration

Model Sizes 210 – 333								
CFM	4500	5000	5500	6000	6500	7000	7500	8000
Vertical & Horizontal	0.047	0.052	0.057	0.062	0.067	0.072	0.077	0.082

Model Sizes 210 – 333									
CFM	8500	9000	9500	10000	10500	11000	11500	12000	12500
Vertical & Horizontal	0.088	0.093	0.098	0.103	0.109	0.114	0.119	0.125	0.131

Electric Heaters – Vertical and Horizontal Duct Donfiguration

Model Sizes 210 – 333								
CFM	4500	5000	5500	6000	6500	7000	7500	8000
25 kW Heater	0.010	0.010	0.015	0.020	0.025	0.030	0.035	0.040
50 kW Heater	0.020	0.020	0.030	0.040	0.050	0.060	0.070	0.080
75 kW Heater	0.030	0.040	0.050	0.060	0.070	0.080	0.100	0.120

Model Sizes 210 – 333									
CFM	8500	9000	9500	10000	10500	11000	11500	12000	12500
25 kW Heater	0.045	0.050	0.055	0.060	0.070	0.080	0.090	0.100	0.105
50 kW Heater	0.090	0.100	0.120	0.130	0.150	0.160	0.180	0.200	0.230
75 kW Heater	0.140	0.150	0.180	0.200	0.230	0.250	0.270	0.300	0.330

General fan performance notes:

1. Interpolation is permissible. Do not extrapolate.
2. External static pressure is the static pressure difference between the return duct and the supply duct plus the static pressure caused by any FIOPs or accessories.
3. Tabular data accounts for pressure loss due to clean filters, high gas heat, unit casing, and wet coils. Factory options and accessories may add static pressure losses, as shown in Table 15.
4. The Fan Performance tables offer motor/drive recommendations. In cases when two motor/drive combinations would work, the lower horsepower option is recommended.
5. For information on the electrical properties of motors, please see the Electrical information section of this book.
6. For more information on the performance limits of motors, see the application data section of this book.

Hot Gas Reheat Coil

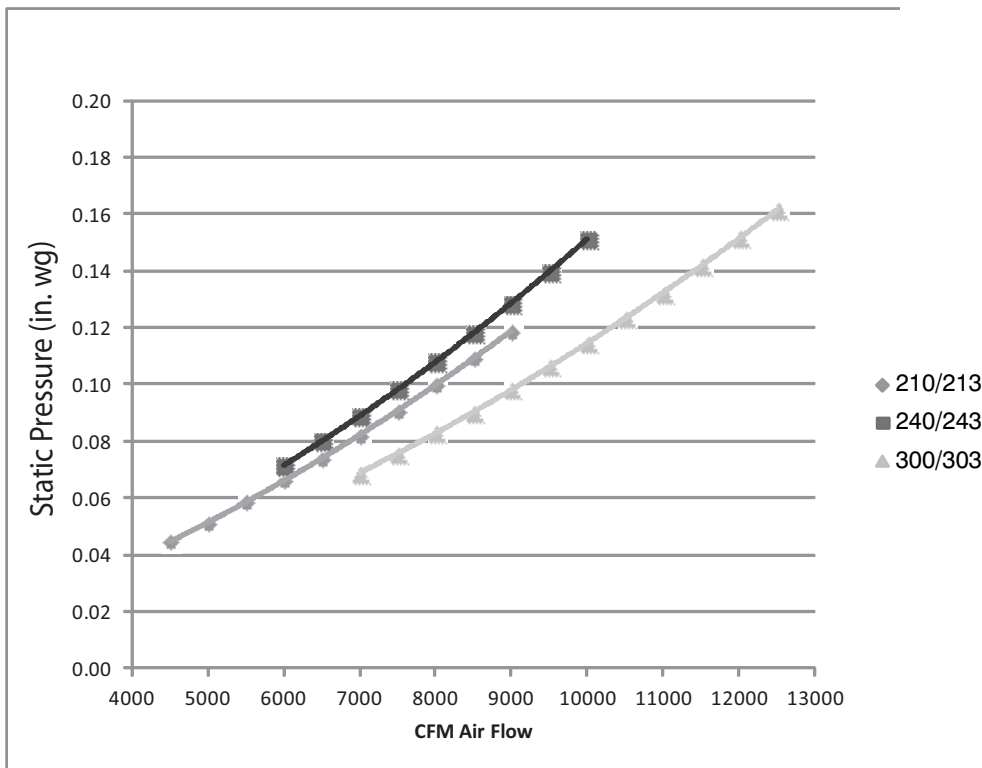

FAN PERFORMANCE

Table 15 – RAS210, 17.5 TON VERTICAL SUPPLY / RETURN

CFM	Available External Static Pressure (in. wg)									
	0.2		0.4		0.6		0.8		1.0	
	RPM	BHP	RPM	BHP	RPM	BHP	RPM	BHP	RPM	BHP
5250	473	0.83	560	1.16	637	1.51	706	1.89	770	2.30
5700	497	0.99	580	1.34	654	1.72	721	2.12	783	2.54
6100	518	1.15	598	1.53	669	1.92	735	2.34	795	2.78
6500	540	1.33	616	1.73	685	2.14	749	2.58	808	3.03
7000	567	1.59	640	2.01	707	2.45	768	2.91	826	3.38
7500	595	1.88	665	2.33	729	2.79	788	3.27	844	3.77
7900	618	2.14	685	2.60	747	3.09	805	3.59	859	4.10
8300	641	2.42	705	2.91	765	3.41	822	3.93	875	4.46
8750	666	2.77	729	3.28	787	3.80	842	4.34	893	4.90

CFM	Available External Static Pressure (in. wg)									
	1.2		1.4		1.6		1.8		2.0	
	RPM	BHP	RPM	BHP	RPM	BHP	RPM	BHP	RPM	BHP
5250	829	2.72	885	3.16	938	3.61	988	4.09	1036	4.57
5700	841	2.98	895	3.43	947	3.91	997	4.40	1044	4.90
6100	852	3.23	906	3.70	957	4.19	1005	4.70	1052	5.22
6500	864	3.50	917	3.99	967	4.50	1015	5.02	1060	5.55
7000	880	3.88	931	4.38	980	4.91	1027	5.45	1072	6.01
7500	897	4.28	947	4.81	995	5.36	1041	5.92	1085	6.49
7900	911	4.63	960	5.18	1007	5.75	1052	6.32	-----	-----
8300	926	5.01	974	5.58	1020	6.16	-----	-----	-----	-----
8750	943	5.47	990	6.05	-----	-----	-----	-----	-----	-----

Std Static Motor and Drive – 622–822 RPM, Max BHP 3.3 Medium Static Motor and Drive – 713–879 RPM, Max BHP 4.9
 High Static Motor and Drive – 882–1078 RPM, Max BHP 6.5 ----- Outside operating range
Boldface – Field-supplied Drive

Table 16 – RAS240, 20 TON VERTICAL SUPPLY / RETURN

CFM	Available External Static Pressure (in. wg)									
	0.2		0.4		0.6		0.8		1.0	
	RPM	BHP	RPM	BHP	RPM	BHP	RPM	BHP	RPM	BHP
6000	506	1.12	593	1.43	668	1.74	736	2.07	798	2.40
6500	533	1.36	616	1.70	689	2.04	754	2.39	815	2.74
7000	561	1.64	640	2.01	710	2.37	774	2.74	833	3.11
7500	588	1.96	664	2.35	732	2.74	795	3.13	852	3.53
8000	617	2.32	689	2.74	755	3.15	816	3.57	872	3.99
8500	645	2.73	715	3.17	779	3.60	837	4.04	892	4.49
9000	674	3.18	741	3.64	803	4.10	860	4.57	913	5.04
9500	703	3.67	767	4.16	827	4.65	883	5.14	935	5.64
10000	732	4.22	794	4.74	852	5.25	906	5.77	957	6.29

CFM	Available External Static Pressure (in. wg)									
	1.2		1.4		1.6		1.8		2.0	
	RPM	BHP	RPM	BHP	RPM	BHP	RPM	BHP	RPM	BHP
6000	855	2.75	909	3.11	959	3.47	1008	3.85	1054	4.24
6500	871	3.11	924	3.48	974	3.87	1022	4.26	1067	4.67
7000	888	3.50	940	3.89	989	4.30	1036	4.71	1081	5.13
7500	906	3.94	957	4.35	1005	4.77	1052	5.20	1096	5.64
8000	925	4.42	975	4.85	1022	5.29	1068	5.74	1111	6.20
8500	944	4.94	993	5.40	1040	5.86	1084	6.33	1127	6.81
9000	964	5.51	1012	5.99	1058	6.48	1102	6.97	1144	7.46
9500	984	6.13	1032	6.64	1077	7.14	1120	7.65	1161	8.17
10000	1006	6.81	1052	7.33	1096	7.86	1138	8.40	-----	-----

Std Static Motor and Drive – 690–863 RPM, Max BHP 4.9 Medium Static Motor and Drive – 835–1021 RPM, Max BHP 6.5
 High Static Motor and Drive – 941–1176 RPM, Max BHP 8.7 ----- Outside operating range
Boldface – Field-supplied Drive

FAN PERFORMANCE (cont.)

Table 17 – RAS300, 25 TON VERTICAL SUPPLY / RETURN

CFM	Available External Static Pressure (in. wg)									
	0.2		0.4		0.6		0.8		1.0	
	RPM	BHP	RPM	BHP	RPM	BHP	RPM	BHP	RPM	BHP
7500	541	1.50	636	1.88	716	2.27	787	2.66	850	3.06
8000	563	1.76	656	2.17	735	2.58	804	3.00	867	3.42
8500	585	2.05	676	2.50	753	2.93	822	3.37	884	3.81
9000	608	2.37	697	2.85	772	3.31	840	3.77	901	4.24
9500	631	2.73	717	3.24	791	3.73	858	4.21	918	4.70
10000	654	3.12	738	3.66	811	4.18	876	4.69	936	5.20
10500	678	3.56	759	4.12	831	4.67	895	5.21	954	5.74
11000	701	4.02	781	4.62	851	5.20	914	5.76	972	6.33
11500	725	4.53	802	5.16	871	5.77	933	6.36	991	6.95
12000	748	5.09	824	5.75	892	6.38	953	7.00	1010	7.62
12500	772	5.68	846	6.38	912	7.04	973	7.69	1029	8.34

CFM	Available External Static Pressure (in. wg)									
	1.2		1.4		1.6		1.8		2.0	
	RPM	BHP	RPM	BHP	RPM	BHP	RPM	BHP	RPM	BHP
7500	909	3.47	963	3.89	1014	4.32	1062	4.77	1108	5.23
8000	925	3.85	978	4.29	1029	4.74	1077	5.20	1122	5.68
8500	941	4.26	994	4.72	1044	5.19	1092	5.67	1137	6.16
9000	957	4.71	1010	5.19	1060	5.67	1107	6.17	1152	6.68
9500	974	5.19	1027	5.69	1076	6.20	1123	6.72	1167	7.24
10000	991	5.72	1043	6.24	1092	6.77	1138	7.30	-----	-----
10500	1009	6.28	1060	6.83	1109	7.37	1155	7.93	-----	-----
11000	1026	6.89	1077	7.46	1125	8.03	1171	8.60	-----	-----
11500	1044	7.54	1095	8.13	1142	8.72	-----	-----	-----	-----
12000	1062	8.23	1112	8.85	-----	-----	-----	-----	-----	-----
12500	-----	-----	-----	-----	-----	-----	-----	-----	-----	-----

Std Static Motor and Drive – 717–911 RPM, Max BHP 4.9 Medium Static Motor and Drive – 913–1116 RPM, Max BHP 6.5
 High Static Motor and Drive – 941–1176 RPM, Max BHP 8.7 ----- Outside operating range
Boldface – Field-supplied Drive

Table 18 – RAS336, 27.5 TON VERTICAL SUPPLY / RETURN

CFM	Available External Static Pressure (in. wg)									
	0.2		0.4		0.6		0.8		1.0	
	RPM	BHP	RPM	BHP	RPM	BHP	RPM	BHP	RPM	BHP
8250	620	1.85	705	2.31	778	2.77	843	3.22	903	3.68
8800	650	2.18	731	2.67	802	3.16	866	3.64	925	4.13
9350	679	2.54	758	3.07	828	3.59	890	4.10	948	4.62
9900	710	2.95	786	3.51	853	4.06	915	4.60	971	5.15
10450	740	3.40	814	3.99	879	4.57	939	5.15	995	5.73
11000	771	3.90	842	4.52	906	5.14	965	5.75	1020	6.35
11550	802	4.45	871	5.10	933	5.75	991	6.39	1044	7.03
12100	833	5.04	900	5.73	961	6.41	1017	7.09	1070	7.76
12650	865	5.70	930	6.42	989	7.13	1044	7.84	1095	8.54
13200	897	6.40	959	7.16	1017	7.90	1071	8.64	1121	9.38
13750	929	7.17	990	7.96	1046	8.74	1098	9.51	1148	10.27

CFM	Available External Static Pressure (in. wg)									
	1.2		1.4		1.6		1.8		2.0	
	RPM	BHP	RPM	BHP	RPM	BHP	RPM	BHP	RPM	BHP
8250	959	4.14	1011	4.61	1059	5.08	1106	5.56	1150	6.05
8800	980	4.62	1031	5.11	1080	5.61	1126	6.12	1169	6.63
9350	1002	5.14	1052	5.66	1100	6.18	1146	6.72	1189	7.25
9900	1024	5.70	1074	6.25	1121	6.80	1166	7.36	1209	7.92
10450	1047	6.30	1096	6.88	1143	7.47	1187	8.05	1230	8.64
11000	1071	6.96	1119	7.57	1165	8.18	1209	8.79	1251	9.41
11550	1095	7.66	1142	8.30	1188	8.94	1231	9.58	1273	10.23
12100	1119	8.42	1166	9.09	1211	9.76	1253	10.43	1295	11.10
12650	1144	9.24	1190	9.93	1234	10.63	1276	11.33	-----	-----
13200	1169	10.10	1215	10.83	1258	11.56	-----	-----	-----	-----
13750	1195	11.03	1240	11.79	-----	-----	-----	-----	-----	-----

Std Static Motor and Drive – 751–954 RPM, Max BHP 6.5 Medium Static Motor and Drive – 920–1190 RPM, Max BHP 10.5
 High Static Motor & Drive – 1015–1299 RPM, Max BHP 11.9 ----- Outside operating range
Boldface – Field-supplied Drive

FAN PERFORMANCE (cont.)

Table 19 – RAS213, 17.5 TON HORIZONTAL SUPPLY / RETURN

CFM	Available External Static Pressure (in. wg)									
	0.2		0.4		0.6		0.8		1.0	
	RPM	BHP	RPM	BHP	RPM	BHP	RPM	BHP	RPM	BHP
5250	498	1.18	573	1.60	640	2.05	701	2.55	756	3.11
5700	526	1.43	599	1.89	663	2.35	721	2.86	776	3.43
6100	552	1.67	622	2.17	684	2.66	741	3.18	794	3.76
6500	579	1.95	646	2.49	706	3.00	761	3.54	813	4.12
7000	612	2.33	677	2.93	734	3.48	788	4.05	837	4.64
7500	646	2.75	708	3.42	764	4.02	815	4.62	863	5.23
7900	673	3.13	734	3.86	788	4.50	838	5.12	884	5.75
8300	700	3.53	760	4.33	812	5.01	861	5.66	906	6.32
8750	731	4.03	789	4.90	840	5.63	887	6.33	----	----

CFM	Available External Static Pressure (in. wg)									
	1.2		1.4		1.6		1.8		2.0	
	RPM	BHP	RPM	BHP	RPM	BHP	RPM	BHP	RPM	BHP
5250	808	3.72	856	4.36	901	5.04	943	5.75	983	6.48
5700	826	4.05	874	4.71	918	5.40	960	6.13	----	----
6100	843	4.38	890	5.05	934	5.75	976	6.50	----	----
6500	861	4.75	907	5.43	951	6.14	----	----	----	----
7000	885	5.28	929	5.96	----	----	----	----	----	----
7500	909	5.88	----	----	----	----	----	----	----	----
7900	929	6.42	----	----	----	----	----	----	----	----
8300	----	----	----	----	----	----	----	----	----	----
8750	----	----	----	----	----	----	----	----	----	----

Std Static Motor and Drive – 622–822 RPM, Max BHP 3.3 Medium Static Motor and Drive – 713–879 RPM, Max BHP 4.9
 High Static Motor and Drive – 882–1078 RPM, Max BHP 6.5 ----- Outside operating range
Boldface – Field-supplied Drive

Table 20 – RAS243, 20 TON HORIZONTAL SUPPLY / RETURN

CFM	Available External Static Pressure (in. wg)									
	0.2		0.4		0.6		0.8		1.0	
	RPM	BHP	RPM	BHP	RPM	BHP	RPM	BHP	RPM	BHP
6000	546	1.57	617	2.10	680	2.67	738	3.29	790	3.93
6500	579	1.90	646	2.46	707	3.07	763	3.71	814	4.39
7000	613	2.28	677	2.87	735	3.51	789	4.19	839	4.89
7500	648	2.71	708	3.34	764	4.01	816	4.72	865	5.46
8000	683	3.20	740	3.86	794	4.57	846	5.30	892	6.08
8500	718	3.76	773	4.45	825	5.18	873	5.95	919	6.75
9000	754	4.37	814	5.10	856	5.87	903	6.67	947	7.50
9500	----	----	840	5.82	887	6.51	933	7.45	976	8.31
10000	----	----	874	6.50	920	7.44	965	8.30	----	----

CFM	Available External Static Pressure (in. wg)									
	1.2		1.4		1.6		1.8		2.0	
	RPM	BHP	RPM	BHP	RPM	BHP	RPM	BHP	RPM	BHP
6000	839	4.60	885	5.29	928	6.01	969	6.75	1008	7.51
6500	862	5.09	907	5.82	950	6.57	990	7.34	1028	8.13
7000	886	5.63	930	6.39	972	7.17	1012	7.97	1050	8.70
7500	911	6.22	954	7.01	995	7.83	1035	8.66	----	----
8000	936	6.87	979	7.69	1019	8.54	----	----	----	----
8500	965	7.58	1004	8.44	----	----	----	----	----	----
9000	990	8.36	----	----	----	----	----	----	----	----
9500	----	----	----	----	----	----	----	----	----	----
10000	----	----	----	----	----	----	----	----	----	----

Std Static Motor and Drive – 690–863 RPM, Max BHP 4.9 Medium Static Motor and Drive – 835–1021 RPM, Max BHP 6.5
 High Static Motor and Drive – 941–1176 RPM, Max BHP 8.7 ----- Outside operating range
Boldface – Field-supplied Drive

FAN PERFORMANCE (cont.)

Table 21 – RAS303, 25 TON HORIZONTAL SUPPLY / RETURN

CFM	Available External Static Pressure (in. wg)									
	0.2		0.4		0.6		0.8		1.0	
	RPM	BHP	RPM	BHP	RPM	BHP	RPM	BHP	RPM	BHP
7500	553	1.92	621	2.46	683	3.07	741	3.72	795	4.42
8000	575	2.21	639	2.77	700	3.39	756	4.07	809	4.78
8500	596	2.52	658	3.10	716	3.73	771	4.43	823	5.16
9000	616	2.86	675	3.44	732	4.10	786	4.80	836	5.55
9500	636	3.22	693	3.82	747	4.48	800	5.20	849	5.97
10000	656	3.60	710	4.21	763	4.89	813	5.62	862	6.40
10500	675	4.02	727	4.64	778	5.32	827	6.07	874	6.86
11000	694	4.46	744	5.09	793	5.79	841	6.50	887	7.34
11500	713	4.93	761	5.57	808	6.27	854	7.03	899	7.84

CFM	Available External Static Pressure (in. wg)									
	1.2		1.4		1.6		1.8		2.0	
	RPM	BHP	RPM	BHP	RPM	BHP	RPM	BHP	RPM	BHP
7500	845	5.14	892	5.90	936	6.68	978	7.48	1018	8.31
8000	859	5.53	905	6.31	949	7.11	991	7.94	-----	-----
8500	872	5.93	918	6.73	961	7.56	1003	8.41	-----	-----
9000	884	6.34	930	7.16	973	8.01	-----	-----	-----	-----
9500	896	6.77	941	7.61	984	8.48	-----	-----	-----	-----
10000	908	7.22	953	8.08	-----	-----	-----	-----	-----	-----
10500	920	7.69	963	8.56	-----	-----	-----	-----	-----	-----
11000	931	8.18	-----	-----	-----	-----	-----	-----	-----	-----
11500	943	8.70	-----	-----	-----	-----	-----	-----	-----	-----

Std Static Motor and Drive – 647–791 RPM, Max BHP 4.9 Medium Static Motor and Drive – 755–923 RPM, Max BHP 6.5
 High Static Motor and Drive – 827–1010 RPM, Max BHP 8.7 ----- Outside operating range
Boldface – Field-supplied Drive

Table 22 – RAS333, 27.5 TON HORIZONTAL SUPPLY / RETURN

CFM	Available External Static Pressure (in. wg)									
	0.2		0.4		0.6		0.8		1.0	
	RPM	BHP	RPM	BHP	RPM	BHP	RPM	BHP	RPM	BHP
8250	709	3.26	760	3.91	811	4.63	859	5.41	906	6.24
8800	750	3.87	798	4.55	845	5.30	892	6.10	936	6.96
9350	791	4.55	836	5.26	881	6.04	925	6.87	968	7.75
9900	832	5.32	875	6.06	918	6.86	959	7.72	1000	8.63
10450	874	6.17	914	6.94	955	7.77	995	8.66	1034	9.59
11000	916	7.11	954	7.91	993	8.77	1031	9.69	1068	10.65
11550	958	8.15	994	8.98	1031	9.87	1067	10.82	1103	11.81
12100	1000	9.28	1035	10.15	1070	11.07	-----	-----	-----	-----
12650	1042	10.53	1076	11.43	-----	-----	-----	-----	-----	-----
13200	1085	11.88	-----	-----	-----	-----	-----	-----	-----	-----

CFM	Available External Static Pressure (in. wg)									
	1.2		1.4		1.6		1.8		2.0	
	RPM	BHP	RPM	BHP	RPM	BHP	RPM	BHP	RPM	BHP
8250	951	7.12	994	8.03	1035	8.97	1075	9.95	1113	10.96
8800	980	7.86	1021	8.80	1062	9.78	1100	10.79	1138	11.83
9350	1010	8.68	1050	9.65	1089	10.66	1127	11.70	-----	-----
9900	1041	9.59	1079	10.58	1117	11.62	-----	-----	-----	-----
10450	1072	10.58	1110	11.60	-----	-----	-----	-----	-----	-----
11000	1105	11.66	-----	-----	-----	-----	-----	-----	-----	-----
11550	-----	-----	-----	-----	-----	-----	-----	-----	-----	-----
12100	-----	-----	-----	-----	-----	-----	-----	-----	-----	-----
12650	-----	-----	-----	-----	-----	-----	-----	-----	-----	-----
13200	-----	-----	-----	-----	-----	-----	-----	-----	-----	-----

Std Static Motor and Drive – 687–873 RPM, Max BHP 6.5 Medium Static Motor and Drive – 857–1047 RPM, Max BHP 10.5
 High Static Motor & Drive – 994–1197 RPM, Max BHP 11.9 ----- Outside operating range
Boldface – Field-supplied Drive

FAN PERFORMANCE (cont.)

Table 23 – PULLEY ADJUSTMENT – VERTICAL

UNIT RAS	MOTOR/DRIVE COMBO	MOTOR PULLEY TURNS OPEN										
		0	0.5	1	1.5	2	2.5	3	3.5	4	4.5	5
210	Standard Static	822	802	782	762	742	722	702	682	662	642	622
	Medium Static	879	862	846	829	813	796	779	763	746	730	713
	High Static	1078	1058	1039	1019	1000	980	960	941	921	902	882
240	Standard Static	863	846	828	811	794	777	759	742	725	707	690
	Medium Static	1021	1002	984	965	947	928	909	891	872	854	835
	High Static	1176	1153	1129	1106	1082	1059	1035	1012	988	965	941
300	Standard Static	911	892	872	853	833	814	795	775	756	736	717
	Medium Static	1116	1096	1075	1055	1035	1015	994	974	954	933	913
	High Static	1176	1153	1129	1106	1082	1059	1035	1012	988	965	941
336	Standard Static	954	934	913	893	873	853	832	812	792	771	751
	Medium Static	1190	1163	1136	1109	1082	1055	1028	1001	974	947	920
	High Static	1299	1271	1243	1216	1188	1160	1132	1104	1077	1049	1015

NOTE: Do not adjust pulley further than 5 turns open.

■ – Factory settings

Table 24 – PULLEY ADJUSTMENT – HORIZONTAL

UNIT RAS	MOTOR/DRIVE COMBO	MOTOR PULLEY TURNS OPEN										
		0	0.5	1	1.5	2	2.5	3	3.5	4	4.5	5
213	Standard Static	822	802	782	762	742	722	702	682	662	642	622
	Medium Static	879	862	846	829	813	796	779	763	746	730	713
	High Static	1078	1058	1039	1019	1000	980	960	941	921	902	882
243	Standard Static	863	846	828	811	794	777	759	742	725	707	690
	Medium Static	1021	1002	984	965	947	928	909	891	872	854	835
	High Static	1176	1153	1129	1106	1082	1059	1035	1012	988	965	941
303	Standard Static	791	777	762	748	733	719	705	690	676	661	647
	Medium Static	923	906	889	873	856	839	822	805	789	772	755
	High Static	1010	992	973	955	937	919	900	882	864	845	827
333	Standard Static	873	854	836	817	799	780	761	743	724	706	687
	Medium Static	1047	1028	1009	990	971	952	933	914	895	876	857
	High Static	1197	1177	1156	1136	1116	1096	1075	1055	1035	1014	994

NOTE: Do not adjust pulley further than 5 turns open.

■ – Factory settings

DAMPER, BAROMETRIC RELIEF, AND PERFORMANCE, 17.5 TO 25 Ton

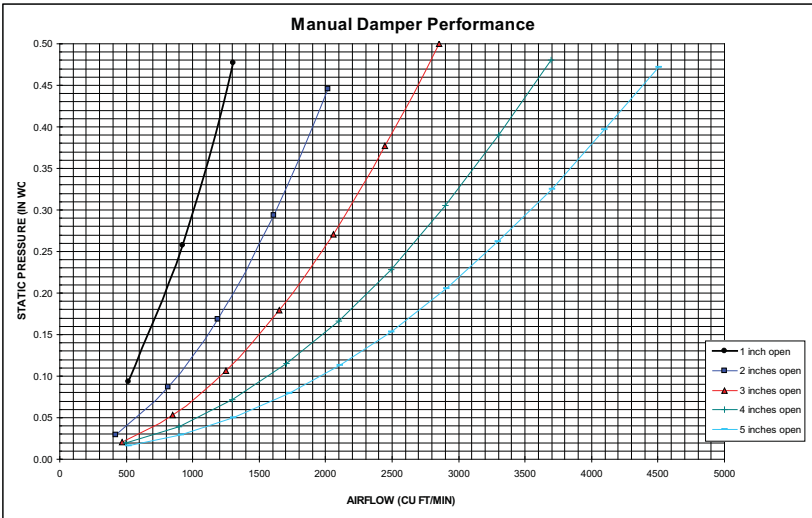

Fig 1 - Manual Damper Performance

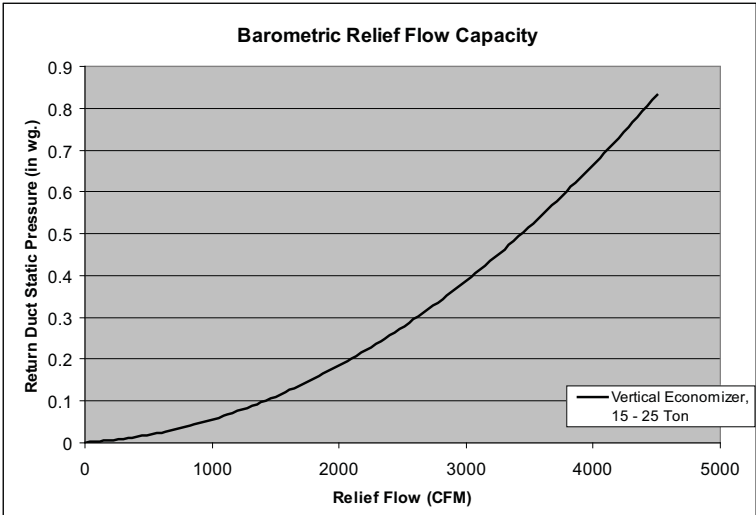

Fig 2 - Barometric Relief Flow Capacity

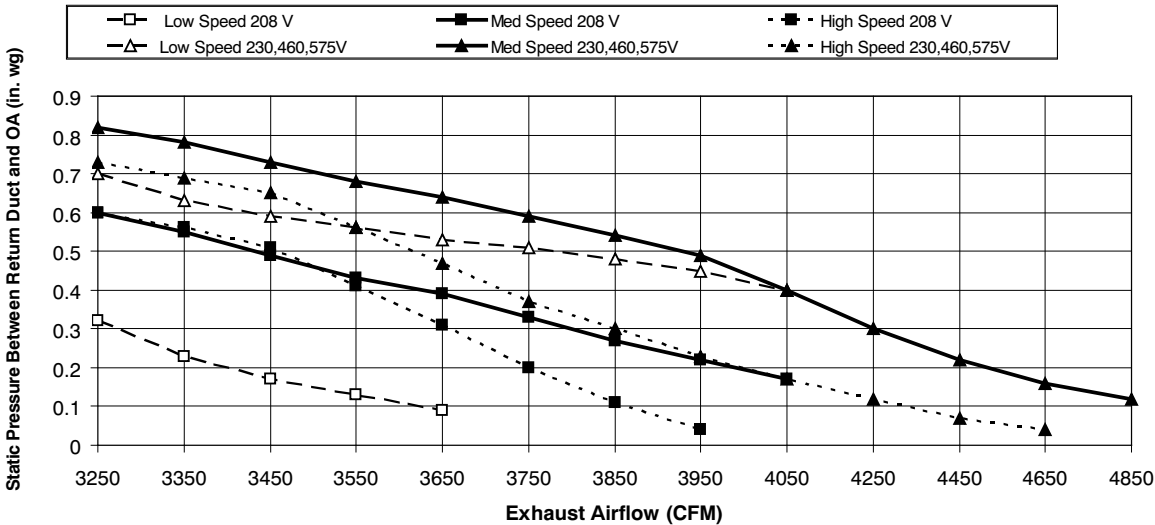

Fig 3 - Power Exhaust Fan Performance

**ELECTRICAL DATA FOR UNITS
PRODUCED ON OR AFTER JULY 30, 2012**

NOTE: Check the serial number of unit to verify production date.

SERIAL NUMBER

1	2	3	4	5	6	7	8	9	10
U	1	2	3	1	1	2	3	4	5

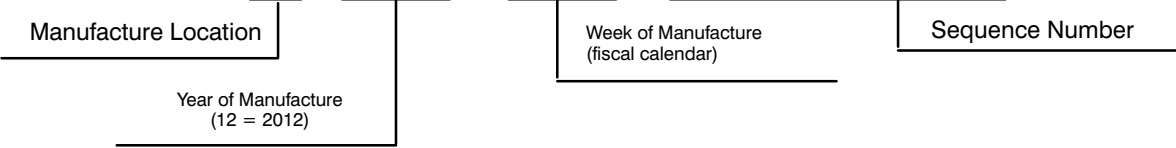

ELECTRICAL INFORMATION (UNITS PRODUCED ON OR AFTER JULY 30, 2012)

TABLE 24 – 2-STAGE COOLING WITH SINGLE SPEED INDOOR FAN MOTOR

17.5 – 27.5 TONS

UNIT RAS	V-Ph-Hz	VOLTAGE RANGE		COMP 1		COMP 2		OFM (ea)		IFM		
		MIN	MAX	RLA	LRA	RLA	LRA	WATTS	FLA	TYPE	EFF at Full Load	FLA
210/213	208-3-60	187	253	29.5	195	30.1	225	350	1.5	STD	87.0%	10.6
										MED	82.9%	13.6
										HIGH	89.5%	17.1
	230-3-60	187	253	29.5	195	30.1	225	350	1.5	STD	87.0%	10.6
										MED	82.9%	12.7
										HIGH	89.5%	17.1
	460-3-60	414	506	14.7	95	16.7	114	277	0.9	STD	87.0%	5.3
										MED	82.9%	6.4
										HIGH	89.5%	8.6
	575-3-60	518	633	12.2	80	12.2	80	397	0.6	STD	81.1%	2.8
										MED	83.6%	5.6
										HIGH	89.5%	7.6
240/243	208-3-60	187	253	48.1	245	29.5	195	350	1.5	STD	82.9%	13.6
										MED	89.5%	17.1
										HIGH	91.7%	28.5
	230-3-60	187	253	48.1	245	29.5	195	350	1.5	STD	82.9%	12.7
										MED	89.5%	17.1
										HIGH	91.7%	28.5
	460-3-60	414	506	18.6	125	14.7	95	277	0.9	STD	82.9%	6.4
										MED	89.5%	8.6
										HIGH	91.7%	14.3
	575-3-60	518	633	14.7	100	12.2	80	397	0.6	STD	83.6%	5.6
										MED	89.5%	7.6
										HIGH	89.5%	7.6
300/303	208-3-60	187	253	48.1	245	48.1	245	350	1.5	STD	82.9%	13.6
										MED	89.5%	17.1
										HIGH	91.7%	28.5
	230-3-60	187	253	48.1	245	48.1	245	350	1.5	STD	82.9%	12.7
										MED	89.5%	17.1
										HIGH	91.7%	28.5
	460-3-60	414	506	18.6	125	18.6	125	277	0.9	STD	82.9%	6.4
										MED	89.5%	8.6
										HIGH	91.7%	14.3
	575-3-60	518	633	14.7	100	14.7	100	397	0.6	STD	83.6%	5.6
										MED	89.5%	7.6
										HIGH	91.7%	9.5
336/303	208-3-60	187	253	51.3	300	51.3	300	350	1.5	STD	89.5%	17.1
										MED	91.7%	28.5
										HIGH	91.7%	30.4
	230-3-60	187	253	51.3	300	51.3	300	350	1.5	STD	89.5%	17.1
										MED	91.7%	28.5
										HIGH	91.7%	30.4
	460-3-60	414	506	23.1	150	23.1	150	277	0.9	STD	89.5%	8.6
										MED	91.7%	14.3
										HIGH	91.7%	15.2
	575-3-60	518	633	19.9	109	19.9	109	397	0.6	STD	89.5%	7.6
										MED	91.7%	9.5
										HIGH	91.7%	12.4

ELECTRICAL INFORMATION

(UNITS PRODUCED ON OR AFTER JULY 30, 2012) cont.

TABLE 25 – 2-STAGE COOLING WITH 2-SPEED INDOOR FAN MOTOR
17.5 – 27.5 TONS

UNIT RAS	V-Ph-Hz	VOLTAGE RANGE		COMP 1		COMP 2		OFM (ea)		IFM		
		MIN	MAX	RLA	LRA	RLA	LRA	WATTS	FLA	TYPE	EFF at Full Load	FLA
210/213	208-3-60	187	253	29.5	195	30.1	225	350	1.5	STD	81.5%	10.8
										MED	83.6%	13.6
										HIGH	89.5%	17.1
	230-3-60	187	253	29.5	195	30.1	225	350	1.5	STD	81.5%	9.8
										MED	83.6%	12.7
										HIGH	89.5%	17.1
	460-3-60	414	506	14.7	95	16.7	114	277	0.9	STD	81.5%	4.9
										MED	83.6%	6.4
										HIGH	89.5%	8.6
	575-3-60	518	633	12.2	80	12.2	80	397	0.6	STD	81.1%	4.5
										MED	83.6%	6.2
										HIGH	89.5%	7.6
240/243	208-3-60	187	253	48.1	245	29.5	195	350	1.5	STD	83.6%	13.6
										MED	89.5%	17.1
										HIGH	91.7%	28.5
	230-3-60	187	253	48.1	245	29.5	195	350	1.5	STD	83.6%	12.7
										MED	89.5%	17.1
										HIGH	91.7%	28.5
	460-3-60	414	506	18.6	125	14.7	95	277	0.9	STD	83.6%	6.4
										MED	89.5%	8.6
										HIGH	91.7%	14.3
	575-3-60	518	633	14.7	100	12.2	80	397	0.6	STD	83.6%	6.2
										MED	89.5%	7.6
										HIGH	91.7%	9.5
300/303	208-3-60	187	253	48.1	245	48.1	245	350	1.5	STD	83.6%	13.6
										MED	89.5%	17.1
										HIGH	91.7%	28.5
	230-3-60	187	253	48.1	245	48.1	245	350	1.5	STD	83.6%	12.7
										MED	89.5%	17.1
										HIGH	91.7%	28.5
	460-3-60	414	506	18.6	125	18.6	125	277	0.9	STD	83.6%	6.4
										MED	89.5%	8.6
										HIGH	91.7%	14.3
	575-3-60	518	633	14.7	100	14.7	100	397	0.6	STD	83.6%	6.2
										MED	89.5%	7.6
										HIGH	91.7%	9.5
336/333	208-3-60	187	253	51.3	300	51.3	300	350	1.5	STD	89.5%	17.1
										MED	91.7%	28.5
										HIGH	91.7%	30.4
	230-3-60	187	253	51.3	300	51.3	300	350	1.5	STD	89.5%	17.1
										MED	91.7%	28.5
										HIGH	91.7%	30.4
	460-3-60	414	506	23.1	150	23.1	150	277	0.9	STD	89.5%	8.6
										MED	91.7%	14.3
										HIGH	91.7%	15.2
	575-3-60	518	633	19.9	109	19.9	109	397	0.6	STD	89.5%	7.6
										MED	91.7%	9.5
										HIGH	91.7%	12.4

**ELECTRIC HEAT – ELECTRICAL INFORMATION
(UNITS PRODUCED ON OR AFTER JULY 30, 2012) cont.**

TABLE 26 – RAS210/213

1–SPEED INDOOR FAN MOTOR

NOM. V–PH–Hz.	IFM TYPE	ELECTRIC HEATER PART NUMBER CRHEATER	NOM PWR (kW)	APP PWR (kW)	SINGLE POINT KIT PART NUMBER CRSINGLE	
					NO C.O. or UNPWRD C.O.	
					NO P.E.	w/P.E. (pwrd fr/unit)
208/230–3–60	STD	279/270A00	25.0	18.8/23.0	–	–
		280/271A00	50.0	37.6/45.9	056	056
		281/272A00	75.0	56.3/68.9	056	056
	MED	279/270A00	25.0	18.8/23.0	–	–
		280/271A00	50.0	37.6/45.9	056	056
		281/272A00	75.0	56.3/68.9	056	056
	HIGH	279/270A00	25.0	18.8/23.0	–	–
		280/271A00	50.0	37.6/45.9	056	056
		281/272A00	75.0	56.3/68.9	056	056
460–3–60	STD	282/273A00	25.0	23.0	–	–
		283/274A00	50.0	45.9	057	057
		284/275A00	75.0	68.9	057	057
	MED	282/273A00	25.0	23.0	–	–
		283/274A00	50.0	45.9	057	057
		284/275A00	75.0	68.9	057	057
	HIGH	282/273A00	25.0	23.0	–	–
		283/274A00	50.0	45.9	057	057
		284/275A00	75.0	68.9	057	057
575–3–60	STD	285/276A00	24.8	22.8	–	–
		286/277A00	49.6	45.6	–	–
		287/278A00	74.4	68.3	057	057
	MED	285/276A00	24.8	22.8	–	–
		286/277A00	49.6	45.6	–	057
		287/278A00	74.4	68.3	057	057
	HIGH	285/276A00	24.8	22.8	–	–
		286/277A00	49.6	45.6	–	057
		287/278A00	74.4	68.3	057	057

**ELECTRIC HEAT – ELECTRICAL INFORMATION
(UNITS PRODUCED ON OR AFTER JULY 30, 2012) cont.**

TABLE 27 – RAS240/243

1–SPEED INDOOR FAN MOTOR

NOM. V–PH–Hz.	IFM TYPE	ELECTRIC HEATER PART NUMBER CRHEATER	NOM PWR (kW)	APP PWR (kW)	SINGLE POINT KIT PART NUMBER CRSINGLE	
					NO C.O. or UNPWRD C.O.	
					NO P.E.	w/P.E. (pwr fr/unit)
208/203–3–60	STD	279/270A00	25.0	18.8/23.0	056	056
		280/271A00	50.0	37.6/45.9	056	056
		281/272A00	75.0	56.3/68.9	056	056
	MED	279/270A00	25.0	18.8/23.0	056	056
		280/271A00	50.0	37.6/45.9	056	056
		281/272A00	75.0	56.3/68.9	056	056
	HIGH	279/270A00	25.0	18.8/23.0	056	056
		280/271A00	50.0	37.6/45.9	056	056
		281/272A00	75.0	56.3/68.9	056	056
460–3–60	STD	282/273A00	25.0	23.0	–	–
		283/274A00	50.0	45.9	057	057
		284/275A00	75.0	68.9	057	057
	MED	282/273A00	25.0	23.0	–	–
		283/274A00	50.0	45.9	057	057
		284/275A00	75.0	68.9	057	057
	HIGH	282/273A00	25.0	23.0	–	057
		283/274A00	50.0	45.9	057	057
		284/275A00	75.0	68.9	057	057
575–3–60	STD	285/276A00	24.8	22.8	–	–
		286/277A00	49.6	45.6	–	057
		287/278A00	74.4	68.3	057	057
	MED	285/276A00	24.8	22.8	–	–
		286/277A00	49.6	45.6	–	057
		287/278A00	74.4	68.3	057	057
	HIGH	285/276A00	24.8	22.8	–	–
		286/277A00	49.6	45.6	057	057
		287/278A00	74.4	68.3	057	057

**ELECTRIC HEAT – ELECTRICAL INFORMATION
(UNITS PRODUCED ON OR AFTER JULY 30, 2012) cont.**

TABLE 28 – RAS300/303

1–SPEED INDOOR FAN MOTOR

NOM. V–PH–Hz.	IFM TYPE	ELECTRIC HEATER PART NUMBER CRHEATER	NOM PWR (kW)	APP PWR (kW)	SINGLE POINT KIT PART NUMBER CRSINGLE	
					NO C.O. or UNPWRD C.O.	
					NO P.E.	w/P.E. (pwr fr/unit)
208/230–3–60	STD	279/270A00	25.0	18.8/23.0	056	056
		280/271A00	50.0	37.6/45.9	056	056
		281/272A00	75.0	56.3/68.9	056	056
	MED	279/270A00	25.0	18.8/23.0	056	056
		280/271A00	50.0	37.6/45.9	056	056
		281/272A00	75.0	56.3/68.9	056	056
	HIGH	279/270A00	25.0	18.8/23.0	056	056
		280/271A00	50.0	37.6/45.9	056	056
		281/272A00	75.0	56.3/68.9	056	056
460–3–60	STD	282/273A00	25.0	23.0	–	–
		283/274A00	50.0	45.9	057	057
		284/275A00	75.0	68.9	057	057
	MED	282/273A00	25.0	23.0	–	–
		283/274A00	50.0	45.9	057	057
		284/275A00	75.0	68.9	057	057
	HIGH	282/273A00	25.0	23.0	–	057
		283/274A00	50.0	45.9	057	057
		284/275A00	75.0	68.9	057	057
575–3–60	STD	285/276A00	24.8	22.8	–	–
		286/277A00	49.6	45.6	–	057
		287/278A00	74.4	68.3	057	057
	MED	285/276A00	24.8	22.8	–	–
		286/277A00	49.6	45.6	–	057
		287/278A00	74.4	68.3	057	057
	HIGH	285/276A00	24.8	22.8	–	–
		286/277A00	49.6	45.6	057	057
		287/278A00	74.4	68.3	057	057

**ELECTRIC HEAT – ELECTRICAL INFORMATION
(UNITS PRODUCED ON OR AFTER JULY 30, 2012) cont.**

TABLE 29 – RAS336/333

1–SPEED INDOOR FAN MOTOR

NOM. V–PH–Hz.	IFM TYPE	ELECTRIC HEATER PART NUMBER CRHEATER	NOM PWR (kW)	APP PWR (kW)	SINGLE POINT KIT PART NUMBER CRSINGLE	
					NO C.O. or UNPWRD C.O.	
					NO P.E.	w/P.E. (pwr fr/unit)
208/230–3–60	STD	279/270A00	25.0	18.8/23.0	056	056
		280/271A00	50.0	37.6/45.9	056	056
		281/272A00	75.0	56.3/68.9	056	056
	MED	279/270A00	25.0	18.8/23.0	056	056
		280/271A00	50.0	37.6/45.9	056	056
		281/272A00	75.0	56.3/68.9	056	056
	HIGH	279/270A00	25.0	18.8/23.0	056	056
		280/271A00	50.0	37.6/45.9	056	056
		281/272A00	75.0	56.3/68.9	056	056
460–3–60	STD	282/273A00	25.0	23.0	057	057
		283/274A00	50.0	45.9	057	057
		284/275A00	75.0	68.9	057	057
	MED	282/273A00	25.0	23.0	057	057
		283/274A00	50.0	45.9	057	057
		284/275A00	75.0	68.9	057	057
	HIGH	282/273A00	25.0	23.0	057	057
		283/274A00	50.0	45.9	057	057
		284/275A00	75.0	68.9	057	057
575–3–60	STD	285/276A00	24.8	22.8	–	057
		286/277A00	49.6	45.6	–	057
		287/278A00	74.4	68.3	057	057
	MED	285/276A00	24.8	22.8	–	057
		286/277A00	49.6	45.6	057	057
		287/278A00	74.4	68.3	057	057
	HIGH	285/276A00	24.8	22.8	057	057
		286/277A00	49.6	45.6	057	057
		287/278A00	74.4	68.3	057	057

**ELECTRIC HEAT – ELECTRICAL INFORMATION
(UNITS PRODUCED ON OR AFTER JULY 30, 2012) cont.**

TABLE 30 – RAS210/213

2–SPEED INDOOR FAN MOTOR

NOM. V–PH–Hz.	IFM TYPE	ELECTRIC HEATER PART NUMBER CRHEATER	NOM PWR (kW)	APP PWR (kW)	SINGLE POINT KIT PART NUMBER CRSINGLE	
					NO C.O. or UNPWRD C.O.	
					NO PE.	w/PE. (pwrd fr/unit)
208/230–3–60	STD	279/270A00	25.0	18.8/23.0	–	–
		280/271A00	50.0	37.6/45.9	056	056
		281/272A00	75.0	56.3/68.9	056	056
	MED	279/270A00	25.0	18.8/23.0	–	–
		280/271A00	50.0	37.6/45.9	056	056
		281/272A00	75.0	56.3/68.9	056	056
	HIGH	279/270A00	25.0	18.8/23.0	–	–
		280/271A00	50.0	37.6/45.9	056	056
		281/272A00	75.0	56.3/68.9	056	056
460–3–60	STD	282/273A00	25.0	23.0	–	–
		283/274A00	50.0	45.9	057	057
		284/275A00	75.0	68.9	057	057
	MED	282/273A00	25.0	23.0	–	–
		283/274A00	50.0	45.9	057	057
		284/275A00	75.0	68.9	057	057
	HIGH	282/273A00	25.0	23.0	–	–
		283/274A00	50.0	45.9	057	057
		284/275A00	75.0	68.9	057	057
575–3–60	STD	285/276A00	24.8	22.8	–	–
		286/277A00	49.6	45.6	–	057
		287/278A00	74.4	68.3	057	057
	MED	285/276A00	24.8	22.8	–	–
		286/277A00	49.6	45.6	–	057
		287/278A00	74.4	68.3	057	057
	HIGH	285/276A00	24.8	22.8	–	–
		286/277A00	49.6	45.6	–	057
		287/278A00	74.4	68.3	057	057

**ELECTRIC HEAT – ELECTRICAL INFORMATION
(UNITS PRODUCED ON OR AFTER JULY 30, 2012) cont.**

TABLE 31 – RAS240/243

2–SPEED INDOOR FAN MOTOR

NOM. V–PH–Hz.	IFM TYPE	ELECTRIC HEATER PART NUMBER CRHEATER	NOM PWR (kW)	APP PWR (kW)	SINGLE POINT KIT PART NUMBER CRSINGLE	
					NO C.O. or UNPWRD C.O.	
					NO P.E.	w/P.E. (pwr fr/unit)
208/203–3–60	STD	279/270A00	25.0	18.8/23.0	056	056
		280/271A00	50.0	37.6/45.9	056	056
		281/272A00	75.0	56.3/68.9	056	056
	MED	279/270A00	25.0	18.8/23.0	056	056
		280/271A00	50.0	37.6/45.9	056	056
		281/272A00	75.0	56.3/68.9	056	056
	HIGH	279/270A00	25.0	18.8/23.0	056	056
		280/271A00	50.0	37.6/45.9	056	056
		281/272A00	75.0	56.3/68.9	056	056
460–3–60	STD	282/273A00	25.0	23.0	–	–
		283/274A00	50.0	45.9	057	057
		284/275A00	75.0	68.9	057	057
	MED	282/273A00	25.0	23.0	–	–
		283/274A00	50.0	45.9	057	057
		284/275A00	75.0	68.9	057	057
	HIGH	282/273A00	25.0	23.0	–	057
		283/274A00	50.0	45.9	057	057
		284/275A00	75.0	68.9	057	057
575–3–60	STD	285/276A00	24.8	22.8	–	–
		286/277A00	49.6	45.6	–	057
		287/278A00	74.4	68.3	057	057
	MED	285/276A00	24.8	22.8	–	–
		286/277A00	49.6	45.6	–	057
		287/278A00	74.4	68.3	057	057
	HIGH	285/276A00	24.8	22.8	–	–
		286/277A00	49.6	45.6	057	057
		287/278A00	74.4	68.3	057	057

**ELECTRIC HEAT – ELECTRICAL INFORMATION
(UNITS PRODUCED ON OR AFTER JULY 30, 2012) cont.**

TABLE 32 – RAS300/303

2–SPEED INDOOR FAN MOTOR

NOM. V–PH–Hz.	IFM TYPE	ELECTRIC HEATER PART NUMBER CRHEATER	NOM PWR (kW)	APP PWR (kW)	SINGLE POINT KIT PART NUMBER CRSINGLE	
					NO C.O. or UNPWRD C.O.	
					NO P.E.	w/P.E. (pwrd fr/unit)
208/230–3–60	STD	279/270A00	25.0	18.8/23.0	056	056
		280/271A00	50.0	37.6/45.9	056	056
		281/272A00	75.0	56.3/68.9	056	056
	MED	279/270A00	25.0	18.8/23.0	056	056
		280/271A00	50.0	37.6/45.9	056	056
		281/272A00	75.0	56.3/68.9	056	056
	HIGH	279/270A00	25.0	18.8/23.0	056	056
		280/271A00	50.0	37.6/45.9	056	056
		281/272A00	75.0	56.3/68.9	056	056
460–3–60	STD	282/273A00	25.0	23.0	–	–
		283/274A00	50.0	45.9	057	057
		284/275A00	75.0	68.9	057	057
	MED	282/273A00	25.0	23.0	–	–
		283/274A00	50.0	45.9	057	057
		284/275A00	75.0	68.9	057	057
	HIGH	282/273A00	25.0	23.0	–	057
		283/274A00	50.0	45.9	057	057
		284/275A00	75.0	68.9	057	057
575–3–60	STD	285/276A00	24.8	22.8	–	–
		286/277A00	49.6	45.6	–	057
		287/278A00	74.4	68.3	057	057
	MED	285/276A00	24.8	22.8	–	–
		286/277A00	49.6	45.6	–	057
		287/278A00	74.4	68.3	057	057
	HIGH	285/276A00	24.8	22.8	–	–
		286/277A00	49.6	45.6	057	057
		287/278A00	74.4	68.3	057	057

**ELECTRIC HEAT – ELECTRICAL INFORMATION
(UNITS PRODUCED ON OR AFTER JULY 30, 2012) cont.**

TABLE 33 – RAS336/333

2–SPEED INDOOR FAN MOTOR

NOM. V–PH–Hz.	IFM TYPE	ELECTRIC HEATER PART NUMBER CRHEATER	NOM PWR (kW)	APP PWR (kW)	SINGLE POINT KIT PART NUMBER CRSINGLE	
					NO C.O. or UNPWRD C.O.	
					NO P.E.	w/P.E. (pwr fr/unit)
208/230–3–60	STD	279/270A00	25.0	18.8/23.0	056	056
		280/271A00	50.0	37.6/45.9	056	056
		281/272A00	75.0	56.3/68.9	056	056
	MED	279/270A00	25.0	18.8/23.0	056	056
		280/271A00	50.0	37.6/45.9	056	056
		281/272A00	75.0	56.3/68.9	056	056
	HIGH	279/270A00	25.0	18.8/23.0	056	056
		280/271A00	50.0	37.6/45.9	056	056
		281/272A00	75.0	56.3/68.9	056	056
460–3–60	STD	282/273A00	25.0	23.0	057	057
		283/274A00	50.0	45.9	057	057
		284/275A00	75.0	68.9	057	057
	MED	282/273A00	25.0	23.0	057	057
		283/274A00	50.0	45.9	057	057
		284/275A00	75.0	68.9	057	057
	HIGH	282/273A00	25.0	23.0	057	057
		283/274A00	50.0	45.9	057	057
		284/275A00	75.0	68.9	057	057
575–3–60	STD	285/276A00	24.8	22.8	–	057
		286/277A00	49.6	45.6	–	057
		287/278A00	74.4	68.3	057	057
	MED	285/276A00	24.8	22.8	–	057
		286/277A00	49.6	45.6	057	057
		287/278A00	74.4	68.3	057	057
	HIGH	285/276A00	24.8	22.8	057	057
		286/277A00	49.6	45.6	057	057
		287/278A00	74.4	68.3	057	057

ELECTRICAL INFORMATION

(UNITS PRODUCED ON OR AFTER JULY 30, 2012) cont.

TABLE 34 – UNIT WIRE/FUSE OR HACR BREAKER SIZING DATA WITH SINGLE SPEED INDOOR FAN MOTOR

Unit RAS	NO M. V. - Ph-Hz	IFM TYPE	ELEC. HTR			NO C.O. or UNPWR C.O.							
			CRHEATER***A00	Nom (kW)	FLA	NO P.E.				w/ P.E. (pwrd fr/unit)			
						MCA	FUSE or HACR BRKR	DISC. SIZE		MCA	FUSE or HACR BRKR	DISC. SIZE	
								FLA	LRA			FLA	LRA
210/213	208/230-3-60	STD	NONE	-	-	82.2	100	86	515	94.0	110	99	535
			279A00	18.8/25.0	52.1/60.1	82.2/88.4	100/100	86/86	515/515	94.0/103.1	110/110	99/99	535/535
			280A00	37.6/50.0	104.2/120.3	143.5/133.6	150/150	132/151	515/515	158.3/148.3	175/175	146/164	535/535
			281A00	56.3/75.0	156.4/180.4	169.7/193.7	200/225	192/220	515/515	184.4/208.4	200/225	206/233	535/535
		MED	NONE	-	-	85.2/84.3	100/100	89/88	517	97.0/96.1	125/125	103/102	537
			279A00	18.8/25.0	52.1/60.1	85.2/91.0	100/100	89/88	517/517	97.0/105.8	125/125	103/102	537/537
			280A00	37.6/50.0	104.2/120.3	147.3/136.2	150/150	135/153	517/517	162.0/150.9	175/175	149/167	537/537
			281A00	56.3/75.0	156.4/180.4	173.4/196.3	200/225	196/222	517/517	188.2/211.0	200/225	209/236	537/537
		HIGH	NONE	-	-	88.7	100	93	513	100.5	125	107	533
	279A00		18.8/25.0	52.1/60.1	88.7/96.5	100/100	93/93	513/513	101.3/111.3	125/125	107/107	533/533	
	280A00		37.6/50.0	104.2/120.3	151.6/141.7	175/175	139/158	513/513	166.4/156.4	175/175	153/172	533/533	
	281A00		56.3/75.0	156.4/180.4	177.8/201.8	200/225	200/227	513/513	192.5/216.5	200/250	213/241	533/533	
	460-3-60	STD	NONE	-	-	43.6	60	45	258	49.8	60	52	270
			282A00	25	30.1	44.3	60	45	258	52	60	52	270
			283A00	50	60.1	66.7	80	75	258	74.5	80	82	270
			284A00	75	90.2	96.8	100	110	258	104.6	110	117	270
		MED	NONE	-	-	44.7	60	47	259	50.9	60	54	271
			282A00	25	30.1	45.6	60	47	259	53.4	60	54	271
			283A00	50	60.1	68.1	80	76	259	75.9	80	84	271
			284A00	75	90.2	98.2	100	111	259	106	125	118	271
		HIGH	NONE	-	-	46.9	60	49	257	53.1	60	56	269
			282A00	25	30.1	48.4	60	49	257	56.1	60	56	269
			283A00	50	60.1	70.9	80	79	257	78.6	80	86	269
			284A00	75	90.2	101	110	114	257	108.7	125	121	269
575-3-60	STD	NONE	-	-	32.1	40	33	188	36.9	45	39	196	
		285A00	24.8	23.9	33.4	40	33	188	39.4	45	39	196	
		286A00	49.6	47.7	63.1	70	58	188	69.1	70	64	196	
		287A00	74.4	71.6	75.1	80	86	188	81.1	90	91	196	
	MED	NONE	-	-	34.9	45	37	202	39.7	50	42	210	
		285A00	24.8	23.9	36.9	45	37	202	42.9	50	42	210	
		286A00	49.6	47.7	66.6	70	61	202	72.6	80	67	210	
		287A00	74.4	71.6	78.6	90	89	202	84.6	90	94	210	
	HIGH	NONE	-	-	36.9	45	39	200	41.7	50	44	208	
		285A00	24.8	23.9	39.4	45	39	200	45.4	50	44	208	
		286A00	49.6	47.7	69.1	70	64	200	75.1	80	69	208	
		287A00	74.4	71.6	81.1	90	91	200	87.1	90	97	208	

ELECTRICAL INFORMATION

(UNITS PRODUCED ON OR AFTER JULY 30, 2012) cont.

TABLE 35 – UNIT WIRE/FUSE OR HACR BREAKER SIZING DATA WITH SINGLE SPEED INDOOR FAN MOTOR

Unit RAS	NO M. V-Ph-HZ	IFM TYPE	ELEC. HTR			NO C.O. or UNPWR C.O.								
			CRHEATER***A00	Nom (kW)	FLA	NO P.E.				w/ P.E. (pwrd fr/unit)				
						MCA	FUSE or HACR BRKR	DISC. SIZE		MCA	FUSE or HACR BRKR	DISC. SIZE		
								FLA	LRA			FLA	LRA	
240/243	208/230-3-60	STD	NONE	-	-	109.2/108.3	150/150	112/111	540	121.0/120.1	150/150	125/124	560	
			279A00	18.8/25.0	52.1/60.1	109.2/108.3	150/150	112/111	540/540	121.0/120.1	150/150	125/124	560/560	
			280A00	37.6/50.0	104.2/120.3	147.3/136.2	150/150	135/153	540/540	162.0/150.9	175/175	149/167	560/560	
			281A00	56.3/75.0	156.4/180.4	173.4/196.3	200/225	196/222	540/540	188.2/211.0	200/225	209/236	560/560	
		MED	NONE	-	-	112.7	150	116	536	124.5	150	129	556	
			279A00	18.8/25.0	52.1/60.1	112.7/112.7	150/150	116/116	536/536	124.5/124.5	150/150	129/129	556/556	
			280A00	37.6/50.0	104.2/120.3	151.6/141.7	175/175	139/158	536/536	166.4/156.4	175/175	153/172	556/556	
		HIGH	281A00	56.3/75.0	156.4/180.4	177.8/201.8	200/225	200/227	536/536	192.5/216.5	200/250	213/241	556/556	
			NONE	-	-	124.1	150	129	615	135.9	175	142	635	
	279A00		18.8/25.0	52.1/60.1	124.1/124.1	150/150	129/129	615/615	135.9/135.9	175/175	142/142	635/635		
	460-3-60	460-3-60	STD	280A00	37.6/50.0	104.2/120.3	165.9/155.9	175/175	153/171	615/615	180.6/170.7	200/175	166/185	635/635
				281A00	56.3/75.0	156.4/180.4	192.0/216.0	200/250	213/240	615/615	206.8/230.8	225/250	226/254	635/635
				NONE	-	-	48.0	60	50	272	54.2	60	57	284
				282A00	25	30.1	48	60	50	272	54.2	60	57	284
			MED	283A00	50	60.1	68.1	80	76	272	75.9	80	84	284
				284A00	75	90.2	98.2	100	111	272	106	125	118	284
				NONE	-	-	50.2	60	52	270	56.4	70	59	282
			HIGH	282A00	25	30.1	50.2	60	52	270	56.4	70	59	282
				283A00	50	60.1	70.9	80	79	270	78.6	80	86	282
		284A00		75	90.2	101	110	114	270	108.7	125	121	282	
		575-3-60	STD	NONE	-	-	55.9	70	59	310	62.1	80	66	322
				282A00	25	30.1	55.9	70	59	310	63.3	80	66	322
				283A00	50	60.1	78	90	86	310	85.7	90	93	322
				284A00	75	90.2	108.1	125	120	310	115.8	125	127	322
MED			NONE	-	-	38.6	50	40	224	43.4	50	46	232	
			285A00	24.8	23.9	38.6	50	40	224	43.4	50	46	232	
			286A00	49.6	47.7	66.6	70	61	224	72.6	80	67	232	
HIGH			287A00	74.4	71.6	78.6	90	89	224	84.6	90	94	232	
			NONE	-	-	40.6	50	42	222	45.4	60	48	230	
		285A00	24.8	23.9	40.6	50	42	222	45.4	60	48	230		
MED		286A00	49.6	47.7	69.1	70	64	222	75.1	80	69	230		
		287A00	74.4	71.6	81.1	90	91	222	87.1	90	97	230		
		NONE	-	-	42.5	50	45	249	47.3	60	50	257		
HIGH		285A00	24.8	23.9	42.5	50	45	249	47.8	60	50	257		
	286A00	49.6	47.7	71.5	80	66	249	77.5	80	71	257			
	287A00	74.4	71.6	83.5	90	93	249	89.5	100	99	257			

ELECTRICAL INFORMATION

(UNITS PRODUCED ON OR AFTER JULY 30, 2012) cont.

TABLE 36 – UNIT WIRE/FUSE OR HACR BREAKER SIZING DATA WITH SINGLE SPEED INDOOR FAN MOTOR

Unit RAS	NO M. V-Ph-HZ	IFM TYPE	ELEC. HTR			NO C.O. or UNPWR C.O.							
			CRHEATER***A00	Nom (kW)	FLA	NO P.E.			w/ P.E. (pwrd fr/unit)				
						MCA	FUSE or HACR BRKR	DISC. SIZE		MCA	FUSE or HACR BRKR	DISC. SIZE	
								FLA	LRA			FLA	LRA
300/303	208/230-3-60	STD	NONE	—	—	127.8/126.9	175/175	133/132	590	139.6/138.7	175/175	147/146	610
			279A00	18.8/25.0	52.1/60.1	127.8/126.9	175/175	133/132	590/590	139.6/138.7	175/175	147/146	610/610
			280A00	37.6/50.0	104.2/120.3	147.3/136.2	175/175	135/153	590/590	162.0/150.9	175/175	149/167	610/610
			281A00	56.3/75.0	156.4/180.4	173.4/196.3	200/225	196/222	590/590	188.2/211.0	200/225	209/236	610/610
		MED	NONE	—	—	131.3	175	137	586	143.1	175	151	606
			279A00	18.8/25.0	52.1/60.1	131.3/131.3	175/175	137/137	586/586	143.1/143.1	175/175	151/151	606/606
			280A00	37.6/50.0	104.2/120.3	151.6/141.7	175/175	139/158	586/586	166.4/156.4	175/175	153/172	606/606
			281A00	56.3/75.0	156.4/180.4	177.8/201.8	200/225	200/227	586/586	192.5/216.5	200/250	213/241	606/606
		HIGH	NONE	—	—	142.7	175	150	665	154.5	200	164	685
			279A00	18.8/25.0	52.1/60.1	142.7/142.7	175/175	150/150	665/665	154.5/154.5	200/200	164/164	685/685
			280A00	37.6/50.0	104.2/120.3	165.9/155.9	175/175	153/171	665/665	180.6/170.7	200/200	166/185	685/685
			281A00	56.3/75.0	156.4/180.4	192.0/216.0	200/250	213/240	665/665	206.8/230.8	225/250	226/254	685/685
	460-3-60	STD	NONE	—	—	51.9	60	54	302	58.1	70	61	314
			282A00	25	30.1	51.9	60	54	302	58.1	70	61	314
			283A00	50	60.1	68.1	80	76	302	75.9	80	84	314
			284A00	75	90.2	98.2	100	111	302	106	125	118	314
		MED	NONE	—	—	54.1	60	57	300	60.3	70	64	312
			282A00	25	30.1	54.1	60	57	300	60.3	70	64	312
			283A00	50	60.1	70.9	80	79	300	78.6	80	86	312
			284A00	75	90.2	101	110	114	300	108.7	125	121	312
		HIGH	NONE	—	—	59.8	70	63	340	66.0	80	70	352
			282A00	25	30.1	59.8	70	63	340	66	80	70	352
			283A00	50	60.1	78	90	86	340	85.7	90	93	352
			284A00	75	90.2	108.1	125	120	340	115.8	125	127	352
	575-3-60	STD	NONE	—	—	41.1	50	43	244	45.9	60	49	252
			285A00	24.8	23.9	41.1	50	43	244	45.9	60	49	252
			286A00	49.6	47.7	66.6	70	61	244	72.6	80	67	252
			287A00	74.4	71.6	78.6	90	89	244	84.6	90	94	252
		MED	NONE	—	—	43.1	50	45	242	47.9	60	51	250
			285A00	24.8	23.9	43.1	50	45	242	47.9	60	51	250
			286A00	49.6	47.7	69.1	70	64	242	75.1	80	69	250
			287A00	74.4	71.6	81.1	90	91	242	87.1	90	97	250
		HIGH	NONE	—	—	45.0	50	47	269	49.8	60	53	277
			285A00	24.8	23.9	45	50	47	269	49.8	60	53	277
			286A00	49.6	47.7	71.5	80	66	269	77.5	80	71	277
			287A00	74.4	71.6	83.5	90	93	269	89.5	100	99	277

ELECTRICAL INFORMATION

(UNITS PRODUCED ON OR AFTER JULY 30, 2012) cont.

TABLE 37 – UNIT WIRE/FUSE OR HACR BREAKER SIZING DATA WITH SINGLE SPEED INDOOR FAN MOTOR

Unit RAS	NO M. V-Ph-HZ	IFM TYPE	ELEC. HTR			NO C.O. or UNPWR C.O.								
			CRHEATER***A00	Nom (kW)	FLA	NO P.E.				w/ P.E. (pwrd fr/unit)				
						MCA	FUSE or HACR BRKR	DISC. SIZE		MCA	FUSE or HACR BRKR	DISC. SIZE		
								FLA	LRA			FLA	LRA	
336/333	208/230-3-60	STD	NONE	-	-	141.5	175	148	702	153.3	200	162	722	
			279A00	18.8/25.0	52.1/60.1	141.5/141.5	175/175	148/148	702/702	153.3/153.3	200/200	162/162	722/722	
			280A00	37.6/50.0	104.2/120.3	151.6/141.7	175/175	148/158	702/702	166.4/156.4	200/200	162/172	722/722	
			281A00	56.3/75.0	156.4/180.4	177.8/201.8	200/225	200/227	702/702	192.5/216.5	200/250	213/241	722/722	
		MED	NONE	-	-	152.9	200	161	781	164.7	200	175	801	
			279A00	18.8/25.0	52.1/60.1	152.9/152.9	200/200	161/161	781/781	164.7/164.7	200/200	175/175	801/801	
			280A00	37.6/50.0	104.2/120.3	165.9/155.9	200/200	161/171	781/781	180.6/170.7	200/200	175/185	801/801	
		HIGH	281A00	56.3/75.0	156.4/180.4	192.0/216.0	200/250	213/240	781/781	206.8/230.8	225/250	226/254	801/801	
			NONE	-	-	154.8	200	163	812	166.6	200	177	832	
	279A00		18.8/25.0	52.1/60.1	154.8/154.8	200/200	163/163	812/812	166.6/166.6	200/200	177/177	832/832		
	460-3-60	460-3-60	STD	280A00	37.6/50.0	104.2/120.3	168.3/158.3	200/200	163/173	812/812	183.0/173.1	200/200	177/187	832/832
				281A00	56.3/75.0	156.4/180.4	194.4/218.4	225/250	215/242	812/812	209.2/233.2	225/250	228/256	832/832
				NONE	-	-	66.0	80	69	354	72.2	90	76	366
				282A00	25	30.1	66	80	69	354	72.2	90	76	366
			MED	283A00	50	60.1	70.9	80	79	354	78.6	90	86	366
				284A00	75	90.2	101	110	114	354	108.7	125	121	366
				NONE	-	-	71.7	90	76	394	77.9	100	83	406
			HIGH	282A00	25	30.1	71.7	90	76	394	77.9	100	83	406
				283A00	50	60.1	78	90	86	394	85.7	100	93	406
		284A00		75	90.2	108.1	125	120	394	115.8	125	127	406	
		575-3-60	STD	NONE	-	-	72.6	90	77	409	78.8	100	84	421
				282A00	25	30.1	72.6	90	77	409	78.8	100	84	421
				283A00	50	60.1	79.1	90	87	409	86.9	100	94	421
				284A00	75	90.2	109.2	125	121	409	117	125	128	421
			MED	NONE	-	-	56.0	70	59	264	60.8	80	64	272
				285A00	24.8	23.9	56	70	59	264	60.8	80	64	272
				286A00	49.6	47.7	69.1	70	64	264	75.1	80	69	272
			HIGH	287A00	74.4	71.6	81.1	90	91	264	87.1	90	97	272
				NONE	-	-	57.9	70	61	291	62.7	80	66	299
		285A00		24.8	23.9	57.9	70	61	291	62.7	80	66	299	
		MED	286A00	49.6	47.7	71.5	80	66	291	77.5	80	71	299	
			287A00	74.4	71.6	83.5	90	93	291	89.5	100	99	299	
			NONE	-	-	60.8	80	64	302	65.6	80	70	310	
		HIGH	285A00	24.8	23.9	60.8	80	64	302	65.6	80	70	310	
			T286A00	49.6	47.7	75.1	80	69	302	81.1	90	75	310	
			287A00	74.4	71.6	87.1	100	97	302	93.1	100	102	310	

ELECTRICAL INFORMATION

(UNITS PRODUCED ON OR AFTER JULY 30, 2012) cont.

TABLE 38 – UNIT WIRE/FUSE OR HACR BREAKER SIZING DATA WITH 2 SPEED INDOOR FAN

Unit RAS	NO M. V-Ph-HZ	IFM TYPE	ELEC. HTR			NO C.O. or UNPWR C.O.							
			CRHEATER***A00	Nom (kW)	FLA	NO P.E.				w/ P.E. (pwrd fr/unit)			
						MCA	FUSE or HACR BRKR	DISC. SIZE		MCA	FUSE or HACR BRKR	DISC. SIZE	
								FLA	LRA			FLA	LRA
210/213	208/230-3-60	STD	NONE	—	—	82.4/81.4	100/100	86/85	506	94.2/93.2	110/110	100/99	526
			279A00	18.8/25.0	52.1/60.1	82.4/87.4	100/100	86/85	506/506	94.2/102.1	110/110	100/99	526/526
			280A00	37.6/50.0	104.2/120.3	143.8/132.6	150/150	132/150	506/506	158.5/147.3	175/175	146/163	526/526
			281A00	56.3/75.0	156.4/180.4	169.9/192.7	200/225	192/219	506/506	184.7/207.4	200/225	206/232	526/526
		MED	NONE	—	—	85.2/84.3	100/100	89/88	517	97.0/96.1	125/125	103/102	537
			279A00	18.8/25.0	52.1/60.1	85.2/91.0	100/100	89/88	517/517	97.0/105.8	125/125	103/102	537/537
			280A00	37.6/50.0	104.2/120.3	147.3/136.2	150/150	135/153	517/517	162.0/150.9	175/175	149/167	537/537
			281A00	56.3/75.0	156.4/180.4	173.4/196.3	200/225	196/222	517/517	188.2/211.0	200/225	209/236	537/537
		HIGH	NONE	—	—	88.7	100	93	513	100.5	125	107	533
			279A00	18.8/25.0	52.1/60.1	88.7/96.5	100/100	93/93	513/513	101.3/111.3	125/125	107/107	533/533
			280A00	37.6/50.0	104.2/120.3	151.6/141.7	175/175	139/158	513/513	166.4/156.4	175/175	153/172	533/533
			281A00	56.3/75.0	156.4/180.4	177.8/201.8	200/225	200/227	513/513	192.5/216.5	200/250	213/241	533/533
	460-3-60	STD	NONE	—	—	43.2	50	45	254	49.4	60	52	266
			282A00	25.0	30.1	43.8	50	45	254	51.5	60	52	266
			283A00	50.0	60.1	66.2	80	75	254	74.0	80	82	266
			284A00	75.0	90.2	96.3	100	109	254	104.1	110	116	266
		MED	NONE	—	—	44.7	60	47	259	50.9	60	54	271
			282A00	25.0	30.1	45.6	60	47	259	53.4	60	54	271
			283A00	50.0	60.1	68.1	80	76	259	75.9	80	84	271
			284A00	75.0	90.2	98.2	100	111	259	106.0	125	118	271
		HIGH	NONE	—	—	46.9	60	49	257	53.1	60	56	269
			282A00	25.0	30.1	48.4	60	49	257	56.1	60	56	269
			283A00	50.0	60.1	70.9	80	79	257	78.6	80	86	269
			284A00	75.0	90.2	101.0	110	114	257	108.7	125	121	269
575-3-60	STD	NONE	—	—	33.8	45	35	188	38.6	50	41	196	
		285A00	24.8	23.9	35.5	45	35	188	41.5	50	41	196	
		286A00	49.6	47.7	65.3	70	60	188	71.3	80	66	196	
		287A00	74.4	71.6	77.2	90	88	188	83.2	90	93	196	
	MED	NONE	—	—	35.5	45	37	202	40.3	50	43	210	
		285A00	24.8	23.9	37.6	45	37	202	43.6	50	43	210	
		286A00	49.6	47.7	67.4	70	62	202	73.4	80	68	210	
		287A00	74.4	71.6	79.4	90	89	202	85.4	90	95	210	
	HIGH	NONE	—	—	36.9	45	39	200	41.7	50	44	208	
		285A00	24.8	23.9	39.4	45	39	200	45.4	50	44	208	
		286A00	49.6	47.7	69.1	70	64	200	75.1	80	69	208	
		287A00	74.4	71.6	81.1	90	91	200	87.1	90	97	208	

ELECTRICAL INFORMATION

(UNITS PRODUCED ON OR AFTER JULY 30, 2012) cont.

TABLE 39 – UNIT WIRE/FUSE OR HACR BREAKER SIZING DATA WITH 2 SPEED INDOOR FAN

Unit RAS	NO M. V-Ph-HZ	IFM TYPE	ELEC. HTR			NO C.O. or UNPWR C.O.							
			CRHEATER***A00	Nom (kW)	FLA	NO P.E.				w/ P.E. (pwrd fr/unit)			
						MCA	FUSE or HACR BRKR	DISC. SIZE		MCA	FUSE or HACR BRKR	DISC. SIZE	
								FLA	LRA			FLA	LRA
240/243	208/230-3-60	STD	NONE	—	—	109.2/108.3	150/150	112/111	540	121.0/120.1	150/150	125/124	560
			279A00	18.8/25.0	52.1/60.1	109.2/108.3	150/150	112/111	540/540	121.0/120.1	150/150	125/124	560/560
			280A00	37.6/50.0	104.2/120.3	147.3/136.2	150/150	135/153	540/540	162.0/150.9	175/175	149/167	560/560
			281A00	56.3/75.0	156.4/180.4	173.4/196.3	200/225	196/222	540/540	188.2/211.0	200/225	209/236	560/560
		MED	NONE	—	—	112.7	150	116	536	124.5	150	129	556
			279A00	18.8/25.0	52.1/60.1	112.7/112.7	150/150	116/116	536/536	124.5/124.5	150/150	129/129	556/556
			280A00	37.6/50.0	104.2/120.3	151.6/141.7	175/175	139/158	536/536	166.4/156.4	175/175	153/172	556/556
			281A00	56.3/75.0	156.4/180.4	177.8/201.8	200/225	200/227	536/536	192.5/216.5	200/250	213/241	556/556
		HIGH	NONE	—	—	124.1	150	129	615	135.9	175	142	635
			279A00	18.8/25.0	52.1/60.1	124.1/124.1	150/150	129/129	615/615	135.9/135.9	175/175	142/142	635/635
			280A00	37.6/50.0	104.2/120.3	165.9/155.9	175/175	153/171	615/615	180.6/170.7	200/175	166/185	635/635
			281A00	56.3/75.0	156.4/180.4	192.0/216.0	200/250	213/240	615/615	206.8/230.8	225/250	226/254	635/635
	460-3-60	STD	NONE	—	—	48.0	60	50	272	54.2	60	57	284
			282A00	25.0	30.1	48.0	60	50	272	54.2	60	57	284
			283A00	50.0	60.1	68.1	80	76	272	75.9	80	84	284
			284A00	75.0	90.2	98.2	100	111	272	106.0	125	118	284
		MED	NONE	—	—	50.2	60	52	270	56.4	70	59	282
			282A00	25.0	30.1	50.2	60	52	270	56.4	70	59	282
			283A00	50.0	60.1	70.9	80	79	270	78.6	80	86	282
			284A00	75.0	90.2	101.0	110	114	270	108.7	125	121	282
		HIGH	NONE	—	—	55.9	70	59	310	62.1	80	66	322
			282A00	25.0	30.1	55.9	70	59	310	63.3	80	66	322
			283A00	50.0	60.1	78.0	90	86	310	85.7	90	93	322
			284A00	75.0	90.2	108.1	125	120	310	115.8	125	127	322
575-3-60	STD	NONE	—	—	39.2	50	41	224	44.0	50	46	232	
		285A00	24.8	23.9	39.2	50	41	224	44.0	50	46	232	
		286A00	49.6	47.7	67.4	70	62	224	73.4	80	68	232	
		287A00	74.4	71.6	79.4	90	89	224	85.4	90	95	232	
	MED	NONE	—	—	40.6	50	42	222	45.4	60	48	230	
		285A00	24.8	23.9	40.6	50	42	222	45.4	60	48	230	
		286A00	49.6	47.7	69.1	70	64	222	75.1	80	69	230	
		287A00	74.4	71.6	81.1	90	91	222	87.1	90	97	230	
	HIGH	NONE	—	—	42.5	50	45	249	47.3	60	50	257	
		285A00	24.8	23.9	42.5	50	45	249	47.8	60	50	257	
		286A00	49.6	47.7	71.5	80	66	249	77.5	80	71	257	
		287A00	74.4	71.6	83.5	90	93	249	89.5	100	99	257	

ELECTRICAL INFORMATION

(UNITS PRODUCED ON OR AFTER JULY 30, 2012) cont.

TABLE 40 – UNIT WIRE/FUSE OR HACR BREAKER SIZING DATA WITH 2 SPEED INDOOR FAN

Unit RAS	NO M. V-Ph-HZ	IFM TYPE	ELEC. HTR			NO C.O. or UNPWR C.O.							
			CRHEATER***A00	Nom (kW)	FLA	NO P.E.				w/ P.E. (pwrd fr/unit)			
						MCA	FUSE or HACR BRKR	DISC. SIZE		MCA	FUSE or HACR BRKR	DISC. SIZE	
								FLA	LRA			FLA	LRA
300/303	208/230-3-60	STD	NONE	—	—	127.8/126.9	175/175	133/132	590	139.6/138.7	175/175	147/146	610
			279A00	18.8/25.0	52.1/60.1	127.8/126.9	175/175	133/132	590/590	139.6/138.7	175/175	147/146	610/610
			280A00	37.6/50.0	104.2/120.3	147.3/136.2	175/175	135/153	590/590	162.0/150.9	175/175	149/167	610/610
			281A00	56.3/75.0	156.4/180.4	173.4/196.3	200/225	196/222	590/590	188.2/211.0	200/225	209/236	610/610
		MED	NONE	—	—	131.3	175	137	586	143.1	175	151	606
			279A00	18.8/25.0	52.1/60.1	131.3/131.3	175/175	137/137	586/586	143.1/143.1	175/175	151/151	606/606
			280A00	37.6/50.0	104.2/120.3	151.6/141.7	175/175	139/158	586/586	166.4/156.4	175/175	153/172	606/606
			281A00	56.3/75.0	156.4/180.4	177.8/201.8	200/225	200/227	586/586	192.5/216.5	200/250	213/241	606/606
		HIGH	NONE	—	—	142.7	175	150	665	154.5	200	164	685
			279A00	18.8/25.0	52.1/60.1	142.7/142.7	175/175	150/150	665/665	154.5/154.5	200/200	164/164	685/685
			280A00	37.6/50.0	104.2/120.3	165.9/155.9	175/175	153/171	665/665	180.6/170.7	200/200	166/185	685/685
			281A00	56.3/75.0	156.4/180.4	192.0/216.0	200/250	213/240	665/665	206.8/230.8	225/250	226/254	685/685
	460-3-60	STD	NONE	—	—	51.9	60	54	302	58.1	70	61	314
			282A00	25.0	30.1	51.9	60	54	302	58.1	70	61	314
			283A00	50.0	60.1	68.1	80	76	302	75.9	80	84	314
			284A00	75.0	90.2	98.2	100	111	302	106.0	125	118	314
		MED	NONE	—	—	54.1	60	57	300	60.3	70	64	312
			282A00	25.0	30.1	54.1	60	57	300	60.3	70	64	312
			283A00	50.0	60.1	70.9	80	79	300	78.6	80	86	312
			284A00	75.0	90.2	101.0	110	114	300	108.7	125	121	312
		HIGH	NONE	—	—	59.8	70	63	340	66.0	80	70	352
			282A00	25.0	30.1	59.8	70	63	340	66.0	80	70	352
			283A00	50.0	60.1	78.0	90	86	340	85.7	90	93	352
			284A00	75.0	90.2	108.1	125	120	340	115.8	125	127	352
575-3-60	STD	NONE	—	—	41.7	50	44	244	46.5	60	49	252	
		285A00	24.8	23.9	41.7	50	44	244	46.5	60	49	252	
		286A00	49.6	47.7	67.4	70	62	244	73.4	80	68	252	
		287A00	74.4	71.6	79.4	90	89	244	85.4	90	95	252	
	MED	NONE	—	—	43.1	50	45	242	47.9	60	51	250	
		285A00	24.8	23.9	43.1	50	45	242	47.9	60	51	250	
		286A00	49.6	47.7	69.1	70	64	242	75.1	80	69	250	
		287A00	74.4	71.6	81.1	90	91	242	87.1	90	97	250	
	HIGH	NONE	—	—	45.0	50	47	269	49.8	60	53	277	
		285A00	24.8	23.9	45.0	50	47	269	49.8	60	53	277	
		286A00	49.6	47.7	71.5	80	66	269	77.5	80	71	277	
		287A00	74.4	71.6	83.5	90	93	269	89.5	100	99	277	

ELECTRICAL INFORMATION

(UNITS PRODUCED ON OR AFTER JULY 30, 2012) cont.

TABLE 41 – UNIT WIRE/FUSE OR HACR BREAKER SIZING DATA WITH 2 SPEED INDOOR FAN

Unit RAS	NO M. V-Ph-HZ	IFM TYPE	ELEC. HTR			NO C.O. or UNPWR C.O.							
			CRHEATER***A00	Nom (kW)	FLA	NO P.E.				w/ P.E. (pwrd fr/unit)			
						MCA	FUSE or HACR BRKR	DISC. SIZE		MCA	FUSE or HACR BRKR	DISC. SIZE	
								FLA	LRA			FLA	LRA
336/333	208/230-3-60	STD	NONE	—	—	141.5	175	148	702	153.3	200	162	722
			279A00	18.8/25.0	52.1/60.1	141.5/141.5	175/175	148/148	702/702	153.3/153.3	200/200	162/162	722/722
			280A00	37.6/50.0	104.2/120.3	151.6/141.7	175/175	148/158	702/702	166.4/156.4	200/200	162/172	722/722
		281A00	56.3/75.0	156.4/180.4	177.8/201.8	200/225	200/227	702/702	192.5/216.5	200/250	213/241	722/722	
		MED	NONE	—	—	152.9	200	161	781	164.7	200	175	801
			279A00	18.8/25.0	52.1/60.1	152.9/152.9	200/200	161/161	781/781	164.7/164.7	200/200	175/175	801/801
			280A00	37.6/50.0	104.2/120.3	165.9/155.9	200/200	161/171	781/781	180.6/170.7	200/200	175/185	801/801
		281A00	56.3/75.0	156.4/180.4	192.0/216.0	200/250	213/240	781/781	206.8/230.8	225/250	226/254	801/801	
		HIGH	NONE	—	—	154.8	200	163	812	166.6	200	177	832
			279A00	18.8/25.0	52.1/60.1	154.8/154.8	200/200	163/163	812/812	166.6/166.6	200/200	177/177	832/832
			280A00	37.6/50.0	104.2/120.3	168.3/158.3	200/200	163/173	812/812	183.0/173.1	200/200	177/187	832/832
		281A00	56.3/75.0	156.4/180.4	194.4/218.4	225/250	215/242	812/812	209.2/233.2	225/250	228/256	832/832	
	460-3-60	STD	NONE	—	—	66.0	80	69	354	72.2	90	76	366
			282A00	25.0	30.1	66.0	80	69	354	72.2	90	76	366
			283A00	50.0	60.1	70.9	80	79	354	78.6	90	86	366
		284A00	75.0	90.2	101.0	110	114	354	108.7	125	121	366	
		MED	NONE	—	—	71.7	90	76	394	77.9	100	83	406
			282A00	25.0	30.1	71.7	90	76	394	77.9	100	83	406
			283A00	50.0	60.1	78.0	90	86	394	85.7	100	93	406
		284A00	75.0	90.2	108.1	125	120	394	115.8	125	127	406	
		HIGH	NONE	—	—	72.6	90	77	409	78.8	100	84	421
			282A00	25.0	30.1	72.6	90	77	409	78.8	100	84	421
			283A00	50.0	60.1	79.1	90	87	409	86.9	100	94	421
		284A00	75.0	90.2	109.2	125	121	409	117.0	125	128	421	
	575-3-60	STD	NONE	—	—	56.0	70	59	264	60.8	80	64	272
			285A00	24.8	23.9	56.0	70	59	264	60.8	80	64	272
			286A00	49.6	47.7	69.1	70	64	264	75.1	80	69	272
		287A00	74.4	71.6	81.1	90	91	264	87.1	90	97	272	
		MED	NONE	—	—	57.9	70	61	291	62.7	80	66	299
			285A00	24.8	23.9	57.9	70	61	291	62.7	80	66	299
			286A00	49.6	47.7	71.5	80	66	291	77.5	80	71	299
		287A00	74.4	71.6	83.5	90	93	291	89.5	100	99	299	
		HIGH	NONE	—	—	60.8	80	64	302	65.6	80	70	310
			285A00	24.8	23.9	60.8	80	64	302	65.6	80	70	310
			286A00	49.6	47.7	75.1	80	69	302	81.1	90	75	310
		287A00	74.4	71.6	87.1	100	97	302	93.1	100	102	310	

LEGEND:

- BRKR — Circuit breaker
- CO — Convenience outlet
- DISC — Disconnect
- FLA — Full load amps
- IFM — Indoor fan motor
- LRA — Locked rotor amps
- MCA — Minimum circuit amps
- MOCP — MAX FUSE or HACR BRKR
- PE — Power exhaust
- PWRD CO — Powered convenient outlet
- UNPWR CO — Unpowered convenient outlet



Example: Supply voltage is 230-3-60

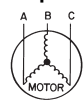

AB = 224 v
BC = 231 v
AC = 226 v

$$\text{Average Voltage} = \frac{(224 + 231 + 226)}{3} = \frac{681}{3} = 227$$

Determine maximum deviation from average voltage.

- (AB) 227 - 224 = 3 v
- (BC) 231 - 227 = 4 v
- (AC) 227 - 226 = 1 v

Maximum deviation is 4 v.

Determine percent of voltage imbalance.

$$\% \text{ Voltage Imbalance} = 100 \times \frac{4}{227} = 1.76\%$$

This amount of phase imbalance is satisfactory as it is below the maximum allowable 2%.

IMPORTANT: If the supply voltage phase imbalance is more than 2%, contact your local electric utility company immediately.

NOTES:

1. In compliance with NEC requirements for multimotor and combination (to NEC Articles 430 and 440), the overcurrent protective device is a fuse or HACR breaker. Canadian units may be fuse or circuit breaker.

1. Unbalanced 3-Phase Supply Voltage

Never operate a motor where a phase imbalance in supply voltage. Use the following formula to determine the percentage of voltage

$$\% \text{ Voltage Imbalance} = 100 \times \frac{\text{max voltage deviation from average voltage}}{\text{average voltage}}$$

ELECTRICAL DATA FOR UNITS PRODUCED PRIOR TO JULY 30, 2012

NOTE: Check the serial number of unit to verify production date.

SERIAL NUMBER

1	2	3	4	5	6	7	8	9	10
U	1	2	3	1	1	2	3	4	5

Manufacture Location

Year of Manufacture
(12 = 2012)

Week of Manufacture
(fiscal calendar)

Sequence Number

ELECTRICAL INFORMATION (UNITS PRODUCED PRIOR TO JULY 30, 2010)

TABLE 42 – 2-STAGE COOLING WITH SINGLE SPEED INDOOR FAN MOTOR

17.5 – 27.5 TONS

UNIT RAS	V-Ph-Hz	VOLTAGE RANGE		COMP 1		COMP 2		OFM (ea)		IFM		
		MIN	MAX	RLA	LRA	RLA	LRA	WATTS	FLA	TYPE	EFF at Full Load	FLA
210/213	208-3-60	187	253	29.5	195	30.1	225	350	1.5	STD	83.8%	10.2
										MED	83.6%	15.0
										HIGH	89.5%	17.1
	230-3-60	187	253	29.5	195	30.1	225	350	1.5	STD	83.8%	10.2
										MED	83.6%	15.0
										HIGH	89.5%	17.1
	460-3-60	414	506	14.7	95	16.7	114	277	0.9	STD	83.8%	4.8
										MED	83.6%	7.4
										HIGH	89.5%	8.6
	575-3-60	518	633	12.2	80	12.2	80	397	0.6	STD	81.1%	2.8
										MED	83.6%	5.6
										HIGH	89.5%	7.6
240/243	208-3-60	187	253	48.1	245	29.5	195	350	1.5	STD	83.6%	15.0
										MED	89.5%	17.1
										HIGH	91.7%	28.5
	230-3-60	187	253	48.1	245	29.5	195	350	1.5	STD	83.6%	15.0
										MED	89.5%	17.1
										HIGH	91.7%	28.5
	460-3-60	414	506	18.6	125	14.7	95	277	0.9	STD	83.6%	7.4
										MED	89.5%	8.6
										HIGH	91.7%	14.3
	575-3-60	518	633	14.7	100	12.2	80	397	0.6	STD	83.6%	5.6
										MED	89.5%	7.6
										HIGH	91.7%	9.5
300/303	208-3-60	187	253	48.1	245	48.1	245	350	1.5	STD	83.6%	15.0
										MED	89.5%	17.1
										HIGH	91.7%	28.5
	230-3-60	187	253	48.1	245	48.1	245	350	1.5	STD	83.6%	15.0
										MED	89.5%	17.1
										HIGH	91.7%	28.5
	460-3-60	414	506	18.6	125	18.6	125	277	0.9	STD	83.6%	7.4
										MED	89.5%	8.6
										HIGH	91.7%	14.3
	575-3-60	518	633	14.7	100	14.7	100	397	0.6	STD	83.6%	5.6
										MED	89.5%	7.6
										HIGH	91.7%	9.5
336/333	208-3-60	187	253	51.3	300	51.3	300	350	1.5	STD	89.5%	17.1
										MED	91.7%	28.5
										HIGH	91.7%	30.4
	230-3-60	187	253	51.3	300	51.3	300	350	1.5	STD	89.5%	17.1
										MED	91.7%	28.5
										HIGH	91.7%	30.4
	460-3-60	414	506	23.1	150	23.1	150	277	0.9	STD	89.5%	8.6
										MED	91.7%	14.3
										HIGH	91.7%	15.2
	575-3-60	518	633	19.9	109	19.9	109	397	0.6	STD	89.5%	7.6
										MED	91.7%	9.5
										HIGH	91.7%	12.4

ELECTRICAL INFORMATION (UNITS PRODUCED PRIOR TO JULY 30, 2010)

TABLE 43 – 2-STAGE COOLING WITH 2-SPEED INDOOR FAN MOTOR

17.5 – 27.5 TONS

UNIT RAS	V-Ph-Hz	VOLTAGE RANGE		COMP 1		COMP 2		OFM (ea)		IFM		
		MIN	MAX	RLA	LRA	RLA	LRA	WATTS	FLA	TYPE	EFF at Full Load	FLA
210/213	208-3-60	187	253	29.5	195	30.1	225	350	1.5	STD	81.5%	10.8
										MED	83.6%	13.6
										HIGH	89.5%	17.1
	230-3-60	187	253	29.5	195	30.1	225	350	1.5	STD	81.5%	9.8
										MED	83.6%	12.7
										HIGH	89.5%	17.1
	460-3-60	414	506	14.7	95	16.7	114	277	0.9	STD	81.5%	4.9
										MED	83.6%	6.4
										HIGH	89.5%	8.6
	575-3-60	518	633	12.2	80	12.2	80	397	0.6	STD	81.1%	4.5
										MED	83.6%	6.2
										HIGH	89.5%	7.6
240/243	208-3-60	187	253	48.1	245	29.5	195	350	1.5	STD	83.6%	13.6
										MED	89.5%	17.1
										HIGH	91.7%	28.5
	230-3-60	187	253	48.1	245	29.5	195	350	1.5	STD	83.6%	12.7
										MED	89.5%	17.1
										HIGH	91.7%	28.5
	460-3-60	414	506	18.6	125	14.7	95	277	0.9	STD	83.6%	6.4
										MED	89.5%	8.6
										HIGH	91.7%	14.3
	575-3-60	518	633	14.7	100	12.2	80	397	0.6	STD	83.6%	6.2
										MED	89.5%	7.6
										HIGH	91.7%	9.5
300/303	208-3-60	187	253	48.1	245	48.1	245	350	1.5	STD	83.6%	13.6
										MED	89.5%	17.1
										HIGH	91.7%	28.5
	230-3-60	187	253	48.1	245	48.1	245	350	1.5	STD	83.6%	12.7
										MED	89.5%	17.1
										HIGH	91.7%	28.5
	460-3-60	414	506	18.6	125	18.6	125	277	0.9	STD	83.6%	6.4
										MED	89.5%	8.6
										HIGH	91.7%	14.3
	575-3-60	518	633	14.7	100	14.7	100	397	0.6	STD	83.6%	6.2
										MED	89.5%	7.6
										HIGH	91.7%	9.5
336/333	208-3-60	187	253	51.3	300	51.3	300	350	1.5	STD	89.5%	17.1
										MED	91.7%	28.5
										HIGH	91.7%	30.4
	230-3-60	187	253	51.3	300	51.3	300	350	1.5	STD	89.5%	17.1
										MED	91.7%	28.5
										HIGH	91.7%	30.4
	460-3-60	414	506	23.1	150	23.1	150	277	0.9	STD	89.5%	8.6
										MED	91.7%	14.3
										HIGH	91.7%	15.2
	575-3-60	518	633	19.9	109	19.9	109	397	0.6	STD	89.5%	7.6
										MED	91.7%	9.5
										HIGH	91.7%	12.4

ELECTRICAL INFORMATION

(UNITS PRODUCED PRIOR TO JULY 30, 2010)

TABLE 44 – ELECTRIC HEAT – ELECTRICAL DATA

17.5 – 20 TONS

2-STAGE COOLING WITH SINGLE SPEED INDOOR FAN MOTOR

Unit RAS	NOM. V-PH-Hz.	IFM TYPE	ELECTRIC HEATER PART NUMBER CRHEATER	NOM PWR (kW)	APP PWR (kW)	SINGLE POINT KIT PART NUMBER CRSINGLE	
						NO C.O. or UNPWRD C.O.	
						NO PE.	w/PE. (pwrd fr/unit)
210/213	208/230-3-60	STD	279/270A00	25.0	18.8/23.0	-	-
			280/271A00	50.0	37.6/45.9	056	056
			281/272A00	75.0	56.3/68.9	056	056
		MED	279/270A00	25.0	18.8/23.0	-	-
			280/271A00	50.0	37.6/45.9	056	056
			281/272A00	75.0	56.3/68.9	056	056
		HIGH	279/270A00	25.0	18.8/23.0	-	-
			280/271A00	50.0	37.6/45.9	056	056
			281/272A00	75.0	56.3/68.9	056	056
	460-3-60	STD	282/273A00	25.0	23.0	-	-
			283/274A00	50.0	45.9	057	057
			284/275A00	75.0	68.9	057	057
		MED	282/273A00	25.0	23.0	-	-
			283/274A00	50.0	45.9	057	057
			284/275A00	75.0	68.9	057	057
		HIGH	282/273A00	25.0	23.0	-	-
			283/274A00	50.0	45.9	057	057
			284/275A00	75.0	68.9	057	057
	575-3-60	STD	285/276A00	24.8	22.8	-	-
			286/277A00	49.6	45.6	-	-
			287/278A00	74.4	68.3	057	057
		MED	285/276A00	24.8	22.8	-	-
			286/277A00	49.6	45.6	-	057
			287/278A00	74.4	68.3	057	057
		HIGH	285/276A00	24.8	22.8	-	-
			286/277A00	49.6	45.6	-	057
			287/278A00	74.4	68.3	057	057
240/243	208/203-3-60	STD	279/270A00	25.0	18.8/23.0	056	056
			280/271A00	50.0	37.6/45.9	056	056
			281/272A00	75.0	56.3/68.9	056	056
		MED	279/270A00	25.0	18.8/23.0	056	056
			280/271A00	50.0	37.6/45.9	056	056
			281/272A00	75.0	56.3/68.9	056	056
		HIGH	279/270A00	25.0	18.8/23.0	056	056
			280/271A00	50.0	37.6/45.9	056	056
			281/272A00	75.0	56.3/68.9	056	056
	460-3-60	STD	282/273A00	25.0	23.0	-	-
			283/274A00	50.0	45.9	057	057
			284/275A00	75.0	68.9	057	057
		MED	282/273A00	25.0	23.0	-	-
			283/274A00	50.0	45.9	057	057
			284/275A00	75.0	68.9	057	057
		HIGH	282/273A00	25.0	23.0	-	057
			283/274A00	50.0	45.9	057	057
			284/275A00	75.0	68.9	057	057
	575-3-60	STD	285/276A00	24.8	22.8	-	-
			286/277A00	49.6	45.6	-	057
			287/278A00	74.4	68.3	057	057
		MED	285/276A00	24.8	22.8	-	-
			286/277A00	49.6	45.6	-	057
			287/278A00	74.4	68.3	057	057
		HIGH	285/276A00	24.8	22.8	-	-
			286/277A00	49.6	45.6	057	057
			287/278A00	74.4	68.3	057	057

LEGEND

APP PWR – 208 / 230V / 460V / 575V

C.O. – Convenient outlet

FLA – Full load amps

IFM – Indoor fan motor

NOM PWR – 240V / 480V / 600V

PE. – Power exhaust

PWRD – Powered convenient outlet

UNPWRD – Unpowered convenient outlet

ELECTRICAL INFORMATION

(UNITS PRODUCED PRIOR TO JULY 30, 2010)

TABLE 45 – ELECTRIC HEAT – ELECTRICAL DATA

25 – 27.5 TONS

2-STAGE COOLING WITH SINGLE SPEED INDOOR FAN MOTOR

Unit RAS	NOM. V–PH–Hz.	IFM TYPE	ELECTRIC HEATER PART NUMBER CRHEATER	NOM PWR (kW)	APP PWR (kW)	SINGLE POINT KIT PART NUMBER	
						CRSINGLE	
						NO C.O. or UNPWRD C.O.	
						NO P.E.	w/P.E. (pwr fr/unit)
300/303	208/230–3–60	STD	279/270A00	25.0	18.8/23.0	056	056
			280/271A00	50.0	37.6/45.9	056	056
			281/272A00	75.0	56.3/68.9	056	056
		MED	279/270A00	25.0	18.8/23.0	056	056
			280/271A00	50.0	37.6/45.9	056	056
			281/272A00	75.0	56.3/68.9	056	056
		HIGH	279/270A00	25.0	18.8/23.0	056	056
			280/271A00	50.0	37.6/45.9	056	056
			281/272A00	75.0	56.3/68.9	056	056
	460–3–60	STD	282/273A00	25.0	23.0	–	–
			283/274A00	50.0	45.9	057	057
			284/275A00	75.0	68.9	057	057
		MED	282/273A00	25.0	23.0	–	–
			283/274A00	50.0	45.9	057	057
			284/275A00	75.0	68.9	057	057
		HIGH	282/273A00	25.0	23.0	–	057
			283/274A00	50.0	45.9	057	057
			284/275A00	75.0	68.9	057	057
	575–3–60	STD	285/276A00	24.8	22.8	–	–
			286/277A00	49.6	45.6	–	057
			287/278A00	74.4	68.3	057	057
		MED	285/276A00	24.8	22.8	–	–
			286/277A00	49.6	45.6	–	057
			287/278A00	74.4	68.3	057	057
		HIGH	285/276A00	24.8	22.8	–	–
			286/277A00	49.6	45.6	057	057
			287/278A00	74.4	68.3	057	057
336/333	208/230–3–60	STD	279/270A00	25.0	18.8/23.0	056	056
			280/271A00	50.0	37.6/45.9	056	056
			281/272A00	75.0	56.3/68.9	056	056
		MED	279/270A00	25.0	18.8/23.0	056	056
			280/271A00	50.0	37.6/45.9	056	056
			281/272A00	75.0	56.3/68.9	056	056
		HIGH	279/270A00	25.0	18.8/23.0	056	056
			280/271A00	50.0	37.6/45.9	056	056
			281/272A00	75.0	56.3/68.9	056	056
	460–3–60	STD	282/273A00	25.0	23.0	057	057
			283/274A00	50.0	45.9	057	057
			284/275A00	75.0	68.9	057	057
		MED	282/273A00	25.0	23.0	057	057
			283/274A00	50.0	45.9	057	057
			284/275A00	75.0	68.9	057	057
		HIGH	282/273A00	25.0	23.0	057	057
			283/274A00	50.0	45.9	057	057
			284/275A00	75.0	68.9	057	057
	575–3–60	STD	285/276A00	24.8	22.8	–	057
			286/277A00	49.6	45.6	–	057
			287/278A00	74.4	68.3	057	057
		MED	285/276A00	24.8	22.8	–	057
			286/277A00	49.6	45.6	057	057
			287/278A00	74.4	68.3	057	057
		HIGH	285/276A00	24.8	22.8	057	057
			286/277A00	49.6	45.6	057	057
			287/278A00	74.4	68.3	057	057

LEGEND

APP PWR – 208 / 230V / 460V / 575V
 C.O. – Convenient outlet
 FLA – Full load amps

IFM – Indoor fan motor
 NOM PWR – 240V / 480V / 600V
 P.E. – Power exhaust

PWRD – Powered convenient outlet
 UNPWRD – Unpowered convenient outlet

ELECTRICAL INFORMATION

(UNITS PRODUCED PRIOR TO JULY 30, 2010)

TABLE 46 – ELECTRIC HEAT – ELECTRICAL DATA

17.5 – 20 TONS

2-STAGE COOLING WITH 2-SPEED INDOOR FAN MOTOR

Unit RAS	NOM. V–PH–Hz.	IFM TYPE	ELECTRIC HEATER PART NUMBER CRHEATER	NOM PWR (kW)	APP PWR (kW)	SINGLE POINT KIT PART NUMBER		
						CRSINGLE		
						NO C.O. or UNPWRD C.O.		
						NO P.E.	w/P.E. (pwrd fr/unit)	
210/213	208/230–3–60	STD	279/270A00	25.0	18.8/23.0	–	–	
			280/271A00	50.0	37.6/45.9	056	056	
			281/272A00	75.0	56.3/68.9	056	056	
		MED	279/270A00	25.0	18.8/23.0	–	–	
			280/271A00	50.0	37.6/45.9	056	056	
			281/272A00	75.0	56.3/68.9	056	056	
		HIGH	279/270A00	25.0	18.8/23.0	–	–	
			280/271A00	50.0	37.6/45.9	056	056	
			281/272A00	75.0	56.3/68.9	056	056	
	460–3–60	STD	282/273A00	25.0	23.0	–	–	
			283/274A00	50.0	45.9	057	057	
			284/275A00	75.0	68.9	057	057	
		MED	282/273A00	25.0	23.0	–	–	
			283/274A00	50.0	45.9	057	057	
			284/275A00	75.0	68.9	057	057	
		HIGH	282/273A00	25.0	23.0	–	–	
			283/274A00	50.0	45.9	057	057	
			284/275A00	75.0	68.9	057	057	
	575–3–60	STD	285/276A00	24.8	22.8	–	–	
			286/277A00	49.6	45.6	–	057	
			287/278A00	74.4	68.3	057	057	
		MED	285/276A00	24.8	22.8	–	–	
			286/277A00	49.6	45.6	–	057	
			287/278A00	74.4	68.3	057	057	
		HIGH	285/276A00	24.8	22.8	–	–	
			286/277A00	49.6	45.6	–	057	
			287/278A00	74.4	68.3	057	057	
	240/243	208/203–3–60	STD	279/270A00	25.0	18.8/23.0	056	056
				280/271A00	50.0	37.6/45.9	056	056
				281/272A00	75.0	56.3/68.9	056	056
MED			279/270A00	25.0	18.8/23.0	056	056	
			280/271A00	50.0	37.6/45.9	056	056	
			281/272A00	75.0	56.3/68.9	056	056	
HIGH			279/270A00	25.0	18.8/23.0	056	056	
			280/271A00	50.0	37.6/45.9	056	056	
			281/272A00	75.0	56.3/68.9	056	056	
460–3–60		STD	282/273A00	25.0	23.0	–	–	
			283/274A00	50.0	45.9	057	057	
			284/275A00	75.0	68.9	057	057	
		MED	282/273A00	25.0	23.0	–	–	
			283/274A00	50.0	45.9	057	057	
			284/275A00	75.0	68.9	057	057	
		HIGH	282/273A00	25.0	23.0	–	057	
			283/274A00	50.0	45.9	057	057	
			284/275A00	75.0	68.9	057	057	
575–3–60		STD	285/276A00	24.8	22.8	–	–	
			286/277A00	49.6	45.6	–	057	
			287/278A00	74.4	68.3	057	057	
		MED	285/276A00	24.8	22.8	–	–	
			286/277A00	49.6	45.6	–	057	
			287/278A00	74.4	68.3	057	057	
		HIGH	285/276A00	24.8	22.8	–	–	
			286/277A00	49.6	45.6	057	057	
			287/278A00	74.4	68.3	057	057	

LEGEND

APP PWR – 208 / 230V / 460V / 575V
 C.O. – Convenient outlet
 FLA – Full load amps

IFM – Indoor fan motor
 NOM PWR – 240V / 480V / 600V
 P.E. – Power exhaust

PWRD – Powered convenient outlet
 UNPWRD – Unpowered convenient outlet

ELECTRICAL INFORMATION

(UNITS PRODUCED PRIOR TO JULY 30, 2010)

TABLE 47 – ELECTRIC HEAT – ELECTRICAL DATA

25 – 27.5 TONS

2-STAGE COOLING WITH 2-SPEED INDOOR FAN MOTOR

Unit RAS	NOM. V–PH–Hz.	IFM TYPE	ELECTRIC HEATER PART NUMBER CRHEATER	NOM PWR (kW)	APP PWR (kW)	SINGLE POINT KIT PART NUMBER	
						CRSINGLE	
						NO C.O. or UNPWRD C.O.	
						NO PE.	w/PE. (pwrd fr/unit)
300/303	208/230–3–60	STD	279/270A00	25.0	18.8/23.0	056	056
			280/271A00	50.0	37.6/45.9	056	056
			281/272A00	75.0	56.3/68.9	056	056
		MED	279/270A00	25.0	18.8/23.0	056	056
			280/271A00	50.0	37.6/45.9	056	056
			281/272A00	75.0	56.3/68.9	056	056
		HIGH	279/270A00	25.0	18.8/23.0	056	056
			280/271A00	50.0	37.6/45.9	056	056
			281/272A00	75.0	56.3/68.9	056	056
	460–3–60	STD	282/273A00	25.0	23.0	–	–
			283/274A00	50.0	45.9	057	057
			284/275A00	75.0	68.9	057	057
		MED	282/273A00	25.0	23.0	–	–
			283/274A00	50.0	45.9	057	057
			284/275A00	75.0	68.9	057	057
		HIGH	282/273A00	25.0	23.0	–	057
			283/274A00	50.0	45.9	057	057
			284/275A00	75.0	68.9	057	057
	575–3–60	STD	285/276A00	24.8	22.8	–	–
			286/277A00	49.6	45.6	–	057
			287/278A00	74.4	68.3	057	057
		MED	285/276A00	24.8	22.8	–	–
			286/277A00	49.6	45.6	–	057
			287/278A00	74.4	68.3	057	057
HIGH		285/276A00	24.8	22.8	–	–	
		286/277A00	49.6	45.6	057	057	
		287/278A00	74.4	68.3	057	057	
336/333	208/230–3–60	STD	279/270A00	25.0	18.8/23.0	056	056
			280/271A00	50.0	37.6/45.9	056	056
			281/272A00	75.0	56.3/68.9	056	056
		MED	279/270A00	25.0	18.8/23.0	056	056
			280/271A00	50.0	37.6/45.9	056	056
			281/272A00	75.0	56.3/68.9	056	056
		HIGH	279/270A00	25.0	18.8/23.0	056	056
			280/271A00	50.0	37.6/45.9	056	056
			281/272A00	75.0	56.3/68.9	056	056
	460–3–60	STD	282/273A00	25.0	23.0	057	057
			283/274A00	50.0	45.9	057	057
			284/275A00	75.0	68.9	057	057
		MED	282/273A00	25.0	23.0	057	057
			283/274A00	50.0	45.9	057	057
			284/275A00	75.0	68.9	057	057
		HIGH	282/273A00	25.0	23.0	057	057
			283/274A00	50.0	45.9	057	057
			284/275A00	75.0	68.9	057	057
	575–3–60	STD	285/276A00	24.8	22.8	–	057
			286/277A00	49.6	45.6	–	057
			287/278A00	74.4	68.3	057	057
		MED	285/276A00	24.8	22.8	–	057
			286/277A00	49.6	45.6	057	057
			287/278A00	74.4	68.3	057	057
HIGH		285/276A00	24.8	22.8	057	057	
		286/277A00	49.6	45.6	057	057	
		287/278A00	74.4	68.3	057	057	

LEGEND

APP PWR – 208 / 230V / 460V / 575V
 C.O. – Convenient outlet
 FLA – Full load amps

IFM – Indoor fan motor
 NOM PWR – 240V / 480V / 600V
 PE. – Power exhaust

PWRD – Powered convenient outlet
 UNPWRD – Unpowered convenient outlet

ELECTRICAL INFORMATION

(UNITS PRODUCED PRIOR TO JULY 30, 2012) cont.

TABLE 48 – RAS210/213 UNIT WIRE/FUSE OR HACR BREAKER SIZING DATA 2-STAGE COOLING WITH SINGLE SPEED INDOOR FAN MOTOR

NOM. V–Ph–Hz	IFM TYPE	ELECTRIC HEATER		NO C.O. or UNPWR C.O.							
		Nom (kW)	FLA	NO P.E.				w/ P.E. (pwrd fr/unit)			
				MCA	MAX FUSE or HACR BRKR	DISC. SIZE		MCA	MAX FUSE or HACR BRKR	DISC. SIZE	
						FLA	LRA			FLA	LRA
208/230–3–60	STD	–	–	81.8	100.0	85	502	93.6	110.0	99	522
		18.8/25.0	52.1/60.1	81.8/87.9	100/100	85/85	502/502	93.6/102.6	110/110	99/99	522/522
		37.6/50.0	104.2/120.3	143.0/133.1	150/150	132/150	502/502	157.8/147.8	175/175	145/164	522/522
		56.3/75.0	156.4/180.4	169.2/193.2	200/225	192/219	502/502	183.9/207.9	200/225	205/233	522/522
	MED	–	–	86.6	100.0	91	511	98.4	125.0	105	531
		18.8/25.0	52.1/60.1	86.6/93.9	100/100	91/91	511/511	98.6/108.6	125/125	105/105	531/531
		37.6/50.0	104.2/120.3	149.0/139.1	150/175	137/156	511/511	163.8/153.8	175/175	151/169	531/531
		56.3/75.0	156.4/180.4	175.2/199.2	200/225	197/225	511/511	189.9/213.9	200/250	211/238	531/531
	HIGH	–	–	88.7	100.0	93	513	100.5	125.0	107	533
		18.8/25.0	52.1/60.1	88.7/96.5	100/100	93/93	513/513	101.3/111.3	125/125	107/107	533/533
		37.6/50.0	104.2/120.3	151.6/141.7	175/175	139/158	513/513	166.4/156.4	175/175	153/172	533/533
		56.3/75.0	156.4/180.4	177.8/201.8	200/225	200/227	513/513	192.5/216.5	200/250	213/241	533/533
460–3–60	STD	–	–	43.1	50.0	45	252	49.3	60.0	52	264
		25.0	30.1	43.6	50.0	45	252	51.4	60.0	52	264
		50.0	60.1	66.1	80.0	75	252	73.9	80.0	82	264
		75.0	90.2	96.2	100	109	252	104.0	110	116	264
	MED	–	–	45.7	60.0	48	256	51.9	60.0	55	268
		25.0	30.1	46.9	60.0	48	256	54.6	60.0	55	268
		50.0	60.1	69.4	80.0	78	256	77.1	80.0	85	268
		75.0	90.2	99.5	110	112	256	107.2	125	119	268
	HIGH	–	–	46.9	60.0	49	257	53.1	60.0	56	269
		25.0	30.1	48.4	60.0	49	257	56.1	60.0	56	269
		50.0	60.1	70.9	80.0	79	257	78.6	80.0	86	269
		75.0	90.2	101.0	110	114	257	108.7	125	121	269
575–3–60	STD	–	–	32.1	40.0	33	188	36.9	45.0	39	196
		24.8	23.9	33.4	40.0	33	188	39.4	45.0	39	196
		49.6	47.7	63.1	70.0	58	188	69.1	70.0	64	196
		74.4	71.6	75.1	80	86	188	81.1	90	91	196
	MED	–	–	34.9	45.0	37	202	39.7	50.0	42	210
		24.8	23.9	36.9	45.0	37	202	42.9	50.0	42	210
		49.6	47.7	66.6	70.0	61	202	72.6	80.0	67	210
		74.4	71.6	78.6	90	89	202	84.6	90	94	210
	HIGH	–	–	36.9	45.0	39	200	41.7	50.0	44	208
		24.8	23.9	39.4	45.0	39	200	45.4	50.0	44	208
		49.6	47.7	69.1	70.0	64	200	75.1	80.0	69	208
		74.4	71.6	81.1	90	91	200	87.1	90	97	208

ELECTRICAL INFORMATION (UNITS PRODUCED PRIOR TO JULY 30, 2012) cont.

TABLE 49 – RAS240/243 UNIT WIRE/FUSE OR HACR BREAKER SIZING DATA 2-STAGE COOLING WITH SINGLE SPEED INDOOR FAN MOTOR

NOM. V–Ph–Hz	IFM TYPE	ELECTRIC HEATER		NO C.O. or UNPWR C.O.								
		Nom (kW)	FLA	NO P.E.				w/ P.E. (pwrd fr/unit)				
				MCA	MAX FUSE or HACR BRKR	DISC. SIZE		MCA	MAX FUSE or HACR BRKR	DISC. SIZE		
						FLA	LRA			FLA	LRA	
208/230–3–60	STD	–	–	110.6	150.0	113	534	122.4	150.0	127	554	
		18.8/25.0	52.1/60.1	110.6/110.6	150/150	113/113	534/534	122.4/122.4	150/150	127/127	554/554	
		37.6/50.0	104.2/120.3	149.0/139.1	150/175	137/156	534/534	163.8/153.8	175/175	151/169	554/554	
	MED	56.3/75.0	156.4/180.4	175.2/199.2	200/225	197/225	534/534	189.9/213.9	200/250	211/238	554/554	
		–	–	112.7	150.0	116	536	124.5	150.0	129	556	
		18.8/25.0	52.1/60.1	112.7/112.7	150/150	116/116	536/536	124.5/124.5	150/150	129/129	556/556	
	HIGH	37.6/50.0	104.2/120.3	151.6/141.7	175/175	139/158	536/536	166.4/156.4	175/175	153/172	556/556	
		56.3/75.0	156.4/180.4	177.8/201.8	200/225	200/227	536/536	192.5/216.5	200/250	213/241	556/556	
		–	–	124.1	150.0	129	615	135.9	175.0	142	635	
	460–3–60	STD	18.8/25.0	52.1/60.1	124.1/124.1	150/150	129/129	615/615	135.9/135.9	175/175	142/142	635/635
			37.6/50.0	104.2/120.3	165.9/155.9	175/175	153/171	615/615	180.6/170.7	200/175	166/185	635/635
			56.3/75.0	156.4/180.4	192.0/216.0	200/250	213/240	615/615	206.8/230.8	225/250	226/254	635/635
–			–	49.0	60.0	51	269	55.2	60.0	58	281	
MED		25.0	30.1	49.0	60.0	51	269	55.2	60.0	58	281	
		50.0	60.1	69.4	80.0	78	269	77.1	80.0	85	281	
		75.0	90.2	99.5	110	112	269	107.2	125	119	281	
		–	–	50.2	60.0	52	270	56.4	70.0	59	282	
HIGH		25.0	30.1	50.2	60.0	52	270	56.4	70.0	59	282	
		50.0	60.1	70.9	80.0	79	270	78.6	80.0	86	282	
		75.0	90.2	101.0	110	114	270	108.7	125	121	282	
		–	–	55.9	70.0	59	310	62.1	80.0	66	322	
575–3–60	STD	25.0	30.1	55.9	70.0	59	310	63.3	80.0	66	322	
		50.0	60.1	78.0	90.0	86	310	85.7	90.0	93	322	
		75.0	90.2	108.1	125	120	310	115.8	125	127	322	
		–	–	38.6	50.0	40	224	43.4	50.0	46	232	
MED	24.8	23.9	38.6	50.0	40	224	43.4	50.0	46	232		
	49.6	47.7	66.6	70.0	61	224	72.6	80.0	67	232		
	74.4	71.6	78.6	90	89	224	84.6	90	94	232		
	–	–	40.6	50.0	42	222	45.4	60.0	48	230		
HIGH	24.8	23.9	40.6	50.0	42	222	45.4	60.0	48	230		
	49.6	47.7	69.1	70.0	64	222	75.1	80.0	69	230		
	74.4	71.6	81.1	90	91	222	87.1	90	97	230		
	–	–	42.5	50.0	45	249	47.3	60.0	50	257		
575–3–60	STD	24.8	23.9	42.5	50.0	45	249	47.8	60.0	50	257	
		49.6	47.7	71.5	80.0	66	249	77.5	80.0	71	257	
		74.4	71.6	83.5	90	93	249	89.5	100	99	257	
		–	–	42.5	50.0	45	249	47.3	60.0	50	257	

ELECTRICAL INFORMATION

(UNITS PRODUCED PRIOR TO JULY 30, 2012) cont.

TABLE 50 – RAS300/303 UNIT WIRE/FUSE OR HACR BREAKER SIZING DATA 2-STAGE COOLING WITH SINGLE SPEED INDOOR FAN MOTOR

NOM. V-Ph-Hz	IFM TYPE	ELECTRIC HEATER		NO C.O. or UNPWR C.O.							
		Nom (kW)	FLA	NO P.E.				w/ P.E. (pwrd fr/unit)			
				MCA	MAX FUSE or HACR BRKR	DISC. SIZE		MCA	MAX FUSE or HACR BRKR	DISC. SIZE	
						FLA	LRA			FLA	LRA
208/230-3-60	STD	-	-	129.2	175.0	135	584	141.0	175.0	148	604
		18.8/25.0	52.1/60.1	129.2/129.2	175/175	135/135	584/584	141.0/141.0	175/175	148/148	604/604
		37.6/50.0	104.2/120.3	149.0/139.1	175/175	137/156	584/584	163.8/153.8	175/175	151/169	604/604
		56.3/75.0	156.4/180.4	175.2/199.2	200/225	197/225	584/584	189.9/213.9	200/250	211/238	604/604
	MED	-	-	131.3	175.0	137	586	143.1	175.0	151	606
		18.8/25.0	52.1/60.1	131.3/131.3	175/175	137/137	586/586	143.1/143.1	175/175	151/151	606/606
		37.6/50.0	104.2/120.3	151.6/141.7	175/175	139/158	586/586	166.4/156.4	175/175	153/172	606/606
		56.3/75.0	156.4/180.4	177.8/201.8	200/225	200/227	586/586	192.5/216.5	200/250	213/241	606/606
	HIGH	-	-	142.7	175.0	150	665	154.5	200.0	164	685
		18.8/25.0	52.1/60.1	142.7/142.7	175/175	150/150	665/665	154.5/154.5	200/200	164/164	685/685
		37.6/50.0	104.2/120.3	165.9/155.9	175/175	153/171	665/665	180.6/170.7	200/200	166/185	685/685
		56.3/75.0	156.4/180.4	192.0/216.0	200/250	213/240	665/665	206.8/230.8	225/250	226/254	685/685
460-3-60	STD	-	-	52.9	60.0	55	299	59.1	70.0	63	311
		25.0	30.1	52.9	60.0	55	299	59.1	70.0	63	311
		50.0	60.1	69.4	80.0	78	299	77.1	80.0	85	311
		75.0	90.2	99.5	110	112	299	107.2	125	119	311
	MED	-	-	54.1	60.0	57	300	60.3	70.0	64	312
		25.0	30.1	54.1	60.0	57	300	60.3	70.0	64	312
		50.0	60.1	70.9	80.0	79	300	78.6	80.0	86	312
		75.0	90.2	101.0	110	114	300	108.7	125	121	312
	HIGH	-	-	59.8	70.0	63	340	66.0	80.0	70	352
		25.0	30.1	59.8	70.0	63	340	66.0	80.0	70	352
		50.0	60.1	78.0	90.0	86	340	85.7	90.0	93	352
		75.0	90.2	108.1	125	120	340	115.8	125	127	352
575-3-60	STD	-	-	41.1	50.0	43	244	45.9	60.0	49	252
		24.8	23.9	41.1	50.0	43	244	45.9	60.0	49	252
		49.6	47.7	66.6	70.0	61	244	72.6	80.0	67	252
		74.4	71.6	78.6	90	89	244	84.6	90	94	252
	MED	-	-	43.1	50.0	45	242	47.9	60.0	51	250
		24.8	23.9	43.1	50.0	45	242	47.9	60.0	51	250
		49.6	47.7	69.1	70.0	64	242	75.1	80.0	69	250
		74.4	71.6	81.1	90	91	242	87.1	90	97	250
	HIGH	-	-	45.0	50.0	47	269	49.8	60.0	53	277
		24.8	23.9	45.0	50.0	47	269	49.8	60.0	53	277
		49.6	47.7	71.5	80.0	66	269	77.5	80.0	71	277
		74.4	71.6	83.5	90	93	269	89.5	100	99	277

ELECTRICAL INFORMATION

(UNITS PRODUCED PRIOR TO JULY 30, 2012) cont.

TABLE 51 – RAS336/333 UNIT WIRE/FUSE OR HACR BREAKER SIZING DATA 2-STAGE COOLING WITH SINGLE SPEED INDOOR FAN MOTOR

NOM. V–Ph–Hz	IFM TYPE	ELECTRIC HEATER		NO C.O. or UNPWR C.O.							
		Nom (kW)	FLA	NO P.E.				w/ P.E. (pwrd fr/unit)			
				MCA	MAX FUSE or HACR BRKR	DISC. SIZE		MCA	MAX FUSE or HACR BRKR	DISC. SIZE	
						FLA	LRA			FLA	LRA
208/230–3–60	STD	–	–	141.5	175.0	148	702	153.3	200.0	162	722
		18.8/25.0	52.1/60.1	141.5/141.5	175/175	148/148	702/702	153.3/153.3	200/200	162/162	722/722
		37.6/50.0	104.2/120.3	151.6/141.7	175/175	148/158	702/702	166.4/156.4	200/200	162/172	722/722
		56.3/75.0	156.4/180.4	177.8/201.8	200/225	200/227	702/702	192.5/216.5	200/250	213/241	722/722
	MED	–	–	152.9	200.0	161	781	164.7	200.0	175	801
		18.8/25.0	52.1/60.1	152.9/152.9	200/200	161/161	781/781	164.7/164.7	200/200	175/175	801/801
		37.6/50.0	104.2/120.3	165.9/155.9	200/200	161/171	781/781	180.6/170.7	200/200	175/185	801/801
		56.3/75.0	156.4/180.4	192.0/216.0	200/250	213/240	781/781	206.8/230.8	225/250	226/254	801/801
	HIGH	–	–	154.8	200.0	163	812	166.6	200.0	177	832
		18.8/25.0	52.1/60.1	154.8/154.8	200/200	163/163	812/812	166.6/166.6	200/200	177/177	832/832
		37.6/50.0	104.2/120.3	168.3/158.3	200/200	163/173	812/812	183.0/173.1	200/200	177/187	832/832
		56.3/75.0	156.4/180.4	194.4/218.4	225/250	215/242	812/812	209.2/233.2	225/250	228/256	832/832
460–3–60	STD	–	–	66.0	80.0	69	354	72.2	90.0	76	366
		25.0	30.1	66.0	80.0	69	354	72.2	90.0	76	366
		50.0	60.1	70.9	80.0	79	354	78.6	90.0	86	366
		75.0	90.2	101.0	110	114	354	108.7	125	121	366
	MED	–	–	71.7	90.0	76	394	77.9	100.0	83	406
		25.0	30.1	71.7	90.0	76	394	77.9	100.0	83	406
		50.0	60.1	78.0	90.0	86	394	85.7	100.0	93	406
		75.0	90.2	108.1	125	120	394	115.8	125	127	406
	HIGH	–	–	72.6	90.0	77	409	78.8	100.0	84	421
		25.0	30.1	72.6	90.0	77	409	78.8	100.0	84	421
		50.0	60.1	79.1	90.0	87	409	86.9	100.0	94	421
		75.0	90.2	109.2	125	121	409	117.0	125	128	421
575–3–60	STD	–	–	56.0	70.0	59	264	60.8	80.0	64	272
		24.8	23.9	56.0	70.0	59	264	60.8	80.0	64	272
		49.6	47.7	69.1	70.0	64	264	75.1	80.0	69	272
		74.4	71.6	81.1	90	91	264	87.1	90	97	272
	MED	–	–	57.9	70.0	61	291	62.7	80.0	66	299
		24.8	23.9	57.9	70.0	61	291	62.7	80.0	66	299
		49.6	47.7	71.5	80.0	66	291	77.5	80.0	71	299
		74.4	71.6	83.5	90	93	291	89.5	100	99	299
	HIGH	–	–	60.8	80.0	64	302	65.6	80.0	70	310
		24.8	23.9	60.8	80.0	64	302	65.6	80.0	70	310
		49.6	47.7	75.1	80.0	69	302	81.1	90.0	75	310
		74.4	71.6	87.1	100	97	302	93.1	100	102	310

ELECTRICAL INFORMATION (UNITS PRODUCED PRIOR TO JULY 30, 2012) cont.

TABLE 52 – RAS210/213 UNIT WIRE/FUSE OR HACR BREAKER SIZING DATA 2-STAGE COOLING WITH 2-SPEED INDOOR FAN MOTOR

NOM. V–Ph–Hz	IFM TYPE	ELECTRIC HEATER		NO C.O. or UNPWR C.O.							
		Nom (kW)	FLA	NO P.E.				w/ P.E. (pwrd fr/unit)			
				MCA	MAX FUSE or HACR BRKR	DISC. SIZE		MCA	MAX FUSE or HACR BRKR	DISC. SIZE	
						FLA	LRA			FLA	LRA
208/230–3–60	STD	–	–	82.4/81.4	100/100	86/85	506	94.2/93.2	110/110	100/99	526
		18.8/25.0	52.1/60.1	82.4/87.4	100/100	86/85	506/506	94.2/102.1	110/110	100/99	526/526
		37.6/50.0	104.2/120.3	143.8/132.6	150/150	132/150	506/506	158.5/147.3	175/175	146/163	526/526
		56.3/75.0	156.4/180.4	169.9/192.7	200/225	192/219	506/506	184.7/207.4	200/225	206/232	526/526
	MED	–	–	85.2/84.3	100/100	89/88	517	97.0/96.1	125/125	103/102	537
		18.8/25.0	52.1/60.1	85.2/91.0	100/100	89/88	517/517	97.0/105.8	125/125	103/102	537/537
		37.6/50.0	104.2/120.3	147.3/136.2	150/150	135/153	517/517	162.0/150.9	175/175	149/167	537/537
		56.3/75.0	156.4/180.4	173.4/196.3	200/225	196/222	517/517	188.2/211.0	200/225	209/236	537/537
	HIGH	–	–	88.7	100	93	513	100.5	125	107	533
		18.8/25.0	52.1/60.1	88.7/96.5	100/100	93/93	513/513	101.3/111.3	125/125	107/107	533/533
		37.6/50.0	104.2/120.3	151.6/141.7	175/175	139/158	513/513	166.4/156.4	175/175	153/172	533/533
		56.3/75.0	156.4/180.4	177.8/201.8	200/225	200/227	513/513	192.5/216.5	200/250	213/241	533/533
460–3–60	STD	–	–	43.2	50	45	254	49.4	60	52	266
		25.0	30.1	43.8	50	45	254	51.5	60	52	266
		50.0	60.1	66.2	80	75	254	74.0	80	82	266
		75.0	90.2	96.3	100	109	254	104.1	110	116	266
	MED	–	–	44.7	60	47	259	50.9	60	54	271
		25.0	30.1	45.6	60	47	259	53.4	60	54	271
		50.0	60.1	68.1	80	76	259	75.9	80	84	271
		75.0	90.2	98.2	100	111	259	106.0	125	118	271
	HIGH	–	–	46.9	60	49	257	53.1	60	56	269
		25.0	30.1	48.4	60	49	257	56.1	60	56	269
		50.0	60.1	70.9	80	79	257	78.6	80	86	269
		75.0	90.2	101.0	110	114	257	108.7	125	121	269
575–3–60	STD	–	–	33.8	45	35	188	38.6	50	41	196
		24.8	23.9	35.5	45	35	188	41.5	50	41	196
		49.6	47.7	65.3	70	60	188	71.3	80	66	196
		74.4	71.6	77.2	90	88	188	83.2	90	93	196
	MED	–	–	35.5	45	37	202	40.3	50	43	210
		24.8	23.9	37.6	45	37	202	43.6	50	43	210
		49.6	47.7	67.4	70	62	202	73.4	80	68	210
		74.4	71.6	79.4	90	89	202	85.4	90	95	210
	HIGH	–	–	36.9	45	39	200	41.7	50	44	208
		24.8	23.9	39.4	45	39	200	45.4	50	44	208
		49.6	47.7	69.1	70	64	200	75.1	80	69	208
		74.4	71.6	81.1	90	91	200	87.1	90	97	208

ELECTRICAL INFORMATION (UNITS PRODUCED PRIOR TO JULY 30, 2012) cont.

TABLE 53 – RAS240/243 UNIT WIRE/FUSE OR HACR BREAKER SIZING DATA 2-STAGE COOLING WITH 2-SPEED INDOOR FAN MOTOR

NOM. V–Ph–Hz	IFM TYPE	ELECTRIC HEATER		NO C.O. or UNPWR C.O.							
		Nom (kW)	FLA	NO P.E.				w/ P.E. (pwrd fr/unit)			
				MCA	MAX FUSE or HACR BRKR	DISC. SIZE		MCA	MAX FUSE or HACR BRKR	DISC. SIZE	
						FLA	LRA			FLA	LRA
208/230–3–60	STD	–	–	109.2/108.3	150/150	112/111	540	121.0/120.1	150/150	125/124	560
		18.8/25.0	52.1/60.1	109.2/108.3	150/150	112/111	540/540	121.0/120.1	150/150	125/124	560/560
		37.6/50.0	104.2/120.3	147.3/136.2	150/150	135/153	540/540	162.0/150.9	175/175	149/167	560/560
		56.3/75.0	156.4/180.4	173.4/196.3	200/225	196/222	540/540	188.2/211.0	200/225	209/236	560/560
	MED	–	–	112.7	150	116	536	124.5	150	129	556
		18.8/25.0	52.1/60.1	112.7/112.7	150/150	116/116	536/536	124.5/124.5	150/150	129/129	556/556
		37.6/50.0	104.2/120.3	151.6/141.7	175/175	139/158	536/536	166.4/156.4	175/175	153/172	556/556
		56.3/75.0	156.4/180.4	177.8/201.8	200/225	200/227	536/536	192.5/216.5	200/250	213/241	556/556
	HIGH	–	–	124.1	150	129	615	135.9	175	142	635
		18.8/25.0	52.1/60.1	124.1/124.1	150/150	129/129	615/615	135.9/135.9	175/175	142/142	635/635
		37.6/50.0	104.2/120.3	165.9/155.9	175/175	153/171	615/615	180.6/170.7	200/175	166/185	635/635
		56.3/75.0	156.4/180.4	192.0/216.0	200/250	213/240	615/615	206.8/230.8	225/250	226/254	635/635
460–3–60	STD	–	–	48.0	60	50	272	54.2	60	57	284
		25.0	30.1	48.0	60	50	272	54.2	60	57	284
		50.0	60.1	68.1	80	76	272	75.9	80	84	284
		75.0	90.2	98.2	100	111	272	106.0	125	118	284
	MED	–	–	50.2	60	52	270	56.4	70	59	282
		25.0	30.1	50.2	60	52	270	56.4	70	59	282
		50.0	60.1	70.9	80	79	270	78.6	80	86	282
		75.0	90.2	101.0	110	114	270	108.7	125	121	282
	HIGH	–	–	55.9	70	59	310	62.1	80	66	322
		25.0	30.1	55.9	70	59	310	63.3	80	66	322
		50.0	60.1	78.0	90	86	310	85.7	90	93	322
		75.0	90.2	108.1	125	120	310	115.8	125	127	322
575–3–60	STD	–	–	39.2	50	41	224	44.0	50	46	232
		24.8	23.9	39.2	50	41	224	44.0	50	46	232
		49.6	47.7	67.4	70	62	224	73.4	80	68	232
		74.4	71.6	79.4	90	89	224	85.4	90	95	232
	MED	–	–	40.6	50	42	222	45.4	60	48	230
		24.8	23.9	40.6	50	42	222	45.4	60	48	230
		49.6	47.7	69.1	70	64	222	75.1	80	69	230
		74.4	71.6	81.1	90	91	222	87.1	90	97	230
	HIGH	–	–	42.5	50	45	249	47.3	60	50	257
		24.8	23.9	42.5	50	45	249	47.8	60	50	257
		49.6	47.7	71.5	80	66	249	77.5	80	71	257
		74.4	71.6	83.5	90	93	249	89.5	100	99	257

ELECTRICAL INFORMATION

(UNITS PRODUCED PRIOR TO JULY 30, 2012) cont.

TABLE 54 – RAS300/303 UNIT WIRE/FUSE OR HACR BREAKER SIZING DATA 2-STAGE COOLING WITH 2-SPEED INDOOR FAN MOTOR

NOM. V–Ph–Hz	IFM TYPE	ELECTRIC HEATER		NO C.O. or UNPWR C.O.							
		Nom (kW)	FLA	NO P.E.				w/ P.E. (pwrd fr/unit)			
				MCA	MAX FUSE or HACR BRKR	DISC. SIZE		MCA	MAX FUSE or HACR BRKR	DISC. SIZE	
						FLA	LRA			FLA	LRA
208/230–3–60	STD	–	–	127.8/126.9	175/175	133/132	590	139.6/138.7	175/175	147/146	610
		18.8/25.0	52.1/60.1	127.8/126.9	175/175	133/132	590/590	139.6/138.7	175/175	147/146	610/610
		37.6/50.0	104.2/120.3	147.3/136.2	175/175	135/153	590/590	162.0/150.9	175/175	149/167	610/610
		56.3/75.0	156.4/180.4	173.4/196.3	200/225	196/222	590/590	188.2/211.0	200/225	209/236	610/610
	MED	–	–	131.3	175	137	586	143.1	175	151	606
		18.8/25.0	52.1/60.1	131.3/131.3	175/175	137/137	586/586	143.1/143.1	175/175	151/151	606/606
		37.6/50.0	104.2/120.3	151.6/141.7	175/175	139/158	586/586	166.4/156.4	175/175	153/172	606/606
		56.3/75.0	156.4/180.4	177.8/201.8	200/225	200/227	586/586	192.5/216.5	200/250	213/241	606/606
	HIGH	–	–	142.7	175	150	665	154.5	200	164	685
		18.8/25.0	52.1/60.1	142.7/142.7	175/175	150/150	665/665	154.5/154.5	200/200	164/164	685/685
		37.6/50.0	104.2/120.3	165.9/155.9	175/175	153/171	665/665	180.6/170.7	200/200	166/185	685/685
		56.3/75.0	156.4/180.4	192.0/216.0	200/250	213/240	665/665	206.8/230.8	225/250	226/254	685/685
460–3–60	STD	–	–	51.9	60	54	302	58.1	70	61	314
		25.0	30.1	51.9	60	54	302	58.1	70	61	314
		50.0	60.1	68.1	80	76	302	75.9	80	84	314
		75.0	90.2	98.2	100	111	302	106.0	125	118	314
	MED	–	–	54.1	60	57	300	60.3	70	64	312
		25.0	30.1	54.1	60	57	300	60.3	70	64	312
		50.0	60.1	70.9	80	79	300	78.6	80	86	312
		75.0	90.2	101.0	110	114	300	108.7	125	121	312
	HIGH	–	–	59.8	70	63	340	66.0	80	70	352
		25.0	30.1	59.8	70	63	340	66.0	80	70	352
		50.0	60.1	78.0	90	86	340	85.7	90	93	352
		75.0	90.2	108.1	125	120	340	115.8	125	127	352
575–3–60	STD	–	–	41.7	50	44	244	46.5	60	49	252
		24.8	23.9	41.7	50	44	244	46.5	60	49	252
		49.6	47.7	67.4	70	62	244	73.4	80	68	252
		74.4	71.6	79.4	90	89	244	85.4	90	95	252
	MED	–	–	43.1	50	45	242	47.9	60	51	250
		24.8	23.9	43.1	50	45	242	47.9	60	51	250
		49.6	47.7	69.1	70	64	242	75.1	80	69	250
		74.4	71.6	81.1	90	91	242	87.1	90	97	250
	HIGH	–	–	45.0	50	47	269	49.8	60	53	277
		24.8	23.9	45.0	50	47	269	49.8	60	53	277
		49.6	47.7	71.5	80	66	269	77.5	80	71	277
		74.4	71.6	83.5	90	93	269	89.5	100	99	277

ELECTRICAL INFORMATION (UNITS PRODUCED PRIOR TO JULY 30, 2012) cont.

TABLE 55 – RAS336/333 UNIT WIRE/FUSE OR HACR BREAKER SIZING DATA 2-STAGE COOLING WITH 2-SPEED INDOOR FAN MOTOR

NOM. V–Ph–Hz	IFM TYPE	ELECTRIC HEATER		NO C.O. or UNPWR C.O.							
		Nom (kW)	FLA	NO P.E.				w/ P.E. (pwrd fr/unit)			
				MCA	MAX FUSE or HACR BRKR	DISC. SIZE		MCA	MAX FUSE or HACR BRKR	DISC. SIZE	
						FLA	LRA			FLA	LRA
208/230–3–60	STD	–	–	141.5	175	148	702	153.3	200	162	722
		18.8/25.0	52.1/60.1	141.5/141.5	175/175	148/148	702/702	153.3/153.3	200/200	162/162	722/722
		37.6/50.0	104.2/120.3	151.6/141.7	175/175	148/158	702/702	166.4/156.4	200/200	162/172	722/722
		56.3/75.0	156.4/180.4	177.8/201.8	200/225	200/227	702/702	192.5/216.5	200/250	213/241	722/722
	MED	–	–	152.9	200	161	781	164.7	200	175	801
		18.8/25.0	52.1/60.1	152.9/152.9	200/200	161/161	781/781	164.7/164.7	200/200	175/175	801/801
		37.6/50.0	104.2/120.3	165.9/155.9	200/200	161/171	781/781	180.6/170.7	200/200	175/185	801/801
		56.3/75.0	156.4/180.4	192.0/216.0	200/250	213/240	781/781	206.8/230.8	225/250	226/254	801/801
	HIGH	–	–	154.8	200	163	812	166.6	200	177	832
		18.8/25.0	52.1/60.1	154.8/154.8	200/200	163/163	812/812	166.6/166.6	200/200	177/177	832/832
		37.6/50.0	104.2/120.3	168.3/158.3	200/200	163/173	812/812	183.0/173.1	200/200	177/187	832/832
		56.3/75.0	156.4/180.4	194.4/218.4	225/250	215/242	812/812	209.2/233.2	225/250	228/256	832/832
460–3–60	STD	–	–	66.0	80	69	354	72.2	90	76	366
		25.0	30.1	66.0	80	69	354	72.2	90	76	366
		50.0	60.1	70.9	80	79	354	78.6	90	86	366
		75.0	90.2	101.0	110	114	354	108.7	125	121	366
	MED	–	–	71.7	90	76	394	77.9	100	83	406
		25.0	30.1	71.7	90	76	394	77.9	100	83	406
		50.0	60.1	78.0	90	86	394	85.7	100	93	406
		75.0	90.2	108.1	125	120	394	115.8	125	127	406
	HIGH	–	–	72.6	90	77	409	78.8	100	84	421
		25.0	30.1	72.6	90	77	409	78.8	100	84	421
		50.0	60.1	79.1	90	87	409	86.9	100	94	421
		75.0	90.2	109.2	125	121	409	117.0	125	128	421
575–3–60	STD	–	–	56.0	70	59	264	60.8	80	64	272
		24.8	23.9	56.0	70	59	264	60.8	80	64	272
		49.6	47.7	69.1	70	64	264	75.1	80	69	272
		74.4	71.6	81.1	90	91	264	87.1	90	97	272
	MED	–	–	57.9	70	61	291	62.7	80	66	299
		24.8	23.9	57.9	70	61	291	62.7	80	66	299
		49.6	47.7	71.5	80	66	291	77.5	80	71	299
		74.4	71.6	83.5	90	93	291	89.5	100	99	299
	HIGH	–	–	60.8	80	64	302	65.6	80	70	310
		24.8	23.9	60.8	80	64	302	65.6	80	70	310
		49.6	47.7	75.1	80	69	302	81.1	90	75	310
		74.4	71.6	87.1	100	97	302	93.1	100	102	310

LEGEND:

BRKR	-	Circuit breaker
CO	-	Convenience outlet
DISC	-	Disconnect
FLA	-	Full load amps
IFM	-	Indoor fan motor
LRA	-	Locked rotor amps
MCA	-	Minimum circuit amps
MOCP	-	MAX FUSE or HACR BRKR
PE	-	Power exhaust
PWRD CO	-	Powered convenient outlet
UNPWR CO	-	Unpowered convenient outlet

**NOTES:**

1. In compliance with NEC requirements for multimotor and combination (to NEC Articles 430 and 440), the overcurrent protective device is a fuse or HACR breaker. Canadian units may be fuse or circuit breaker.

1. Unbalanced 3-Phase Supply Voltage

Never operate a motor where a phase imbalance in supply voltage exists. Use the following formula to determine the percentage of voltage imbalance.

$$\% \text{ Voltage Imbalance} = 100 \times \frac{\text{max voltage deviation from average voltage}}{\text{average voltage}}$$

Example: Supply voltage is 230-3-60

$$AB = 224 \text{ v}$$

$$BC = 231 \text{ v}$$

$$AC = 226 \text{ v}$$

$$\text{Average Voltage} = \frac{(224 + 231 + 226)}{3} = \frac{681}{3} = 227$$

Determine maximum deviation from average voltage.

$$(AB) 227 - 224 = 3 \text{ v}$$

$$(BC) 231 - 227 = 4 \text{ v}$$

$$(AC) 227 - 226 = 1 \text{ v}$$

Maximum deviation is 4 v.

Determine percent of voltage imbalance.

$$\% \text{ Voltage Imbalance} = 100 \times \frac{4}{227} = 1.76\%$$

This amount of phase imbalance is satisfactory as it is below the maximum allowable 2%.

IMPORTANT: If the supply voltage phase imbalance is more than 2%, contact your local electric utility company immediately.

SEQUENCE OF OPERATION

General

The sequence below describes the sequence of operation for an electro-mechanical unit with and without a factory installed "Economizer IV or X". For information regarding a direct digital controller, see the start-up, operations, and troubleshooting manual for the applicable controller.

Units with no Economizer

Cooling — (Single speed indoor fan motor)

When the thermostat calls for cooling, terminals G and Y1 are energized. As a result, the indoor-fan contactor (IFC) and the compressor contactor (C1) are energized, causing the indoor-fan motor (IFM), compressor #1, and outdoor fan to start. If the unit has 2 stages of cooling, the thermostat will additionally energize Y2. The Y2 signal will energize compressor contactor #2 (C2), causing compressor #2 to start. Regardless of the number of stages, the outdoor-fan motor runs continuously while unit is cooling.

Cooling (2-speed indoor fan motor) —

Per ASHRAE 90.1 2010 standard section 6.4.3.10.b, during the first stage of cooling operation the VFD will adjust the fan motor to provide 2/3rd of the total cfm established for the unit. When a call for the second stage of cooling is required, the VFD will allow the total cfm for the unit established (100%).

Heating —

NOTE: This unit is sold as cooling only. If electric heaters are required, use only factory-approved electric heaters. They will operate as described below.

Units have either 1 or 2 stages of electric heat. When the thermostat calls for heating, power is applied to the W1 terminal at the unit. The unit control will energize the indoor fan contactor and the first stage of electric heat. On units with 2-stage heating, when additional heating is required, the second stage of electric heat (if equipped) will be energized when power is applied at the W2 terminal on the unit.

Units with an Economizer

Cooling —

When free cooling is not available, the compressors will be controlled by the zone thermostat. When free cooling is available, the outdoor-air damper is modulated by the Economizer IV or X control to provide a 50°F (10°C) to 55°F (13°C) mixed-air temperature into the zone. As the mixed air temperature fluctuates above 55°F (13°C) or below 50°F (10°C) dampers will be modulated (open or close) to bring the mixed-air temperature back within control. If mechanical cooling is utilized with free cooling, the outdoor-air damper will maintain its current position at the time the compressor is started. If the increase in cooling capacity causes the mixed-air temperature to drop below 45°F (7°C), then the outdoor-air damper position will be decreased to the minimum position. If the mixed-air temperature continues to fall, the outdoor-air damper will close. Control returns to normal once the mixed-air temperature rises above 48°F (9°C). The power exhaust fans will be energized and de-energized, if installed, as the outdoor-air damper opens and closes.

If field-installed accessory CO₂ sensors are connected to the economizer IV or X control, a demand controlled ventilation strategy will begin to operate. As the CO₂ level in the zone increases above the CO₂ setpoint, the minimum position of the damper will be increased proportionally. As the CO₂ level

decreases because of the increase in fresh air, the outdoor-air damper will be proportionally closed. For economizer IV or X operation, there must be a thermostat call for the fan (G). If the unit is occupied and the fan is on, the damper will operate at minimum position. Otherwise, the damper will be closed.

When the economizer IV control is in the occupied mode and a call for cooling exists (Y1 on the thermostat), the control will first check for indoor fan operation. If the fan is not on, then cooling will not be activated. If the fan is on, then the control will open the economizer IV damper to the minimum position.

On the initial power to the economizer IV control, it will take the damper up to 2 1/2 minutes before it begins to position itself. After the initial power-up, further changes in damper position can take up to 30 seconds to initiate. Damper movement from full closed to full open (or vice versa) will take between 1 1/2 and 2 1/2 minutes. If free cooling can be used as determined from the appropriate changeover command (switch, dry bulb, enthalpy curve, differential dry bulb, or differential enthalpy), then the control will modulate the dampers open to maintain the mixed-air temperature setpoint at 50°F (10°C) to 55°F (13°C). If there is a further demand for cooling (cooling second stage – Y2 is energized), then the control will bring on compressor stage 1 to maintain the mixed-air temperature setpoint. The economizer IV damper will be open at maximum position. economizer IV operation is limited to a single compressor.

2-Speed Note: When operating in ventilation mode only, the indoor fan motor will automatically adjust to 2/3rd of the total cfm established.

Heating —

The sequence of operation for the heating is the same as a unit with no economizer. The only difference is how the economizer acts. The economizer will stay at the Economizer Minimum Position while the evaporator fan is operating. The outdoor-air damper is closed when the indoor fan is not operating.

Refer to Service and Maintenance Manual for further details.

Hot Gas Reheat System

Units with the factory equipped Hot Gas Reheat option are capable of providing multiple modes of improved dehumidification as a variation of the normal cooling cycle. The Hot Gas Reheat option includes additional valves in the liquid line and discharge line of each refrigerant circuit, a small reheat condenser coil downstream of the evaporator, and Motormaster variable-speed control of some or all outdoor fans. Operation of the revised refrigerant circuit for each mode is described below.

The Hot Gas Reheat system provides three sub-modes of operation: Cool, Reheat1, and Reheat2.

Cool mode – provides a normal ratio of Sensible and Latent Cooling effect from the evaporator coil.

Reheat1 – provides increased Latent Cooling while slightly reducing the Sensible Cooling effect.

Reheat2 – provides normal Latent Cooling but with null or minimum Sensible Cooling effect delivered to the space.

The Reheat1 and Reheat2 modes are available when the unit is not in a Heating mode and when the Low Ambient Lockout switch is closed.

The following diagrams depict piping for Two Stage cooling units.

SEQUENCE OF OPERATION (CONT.)

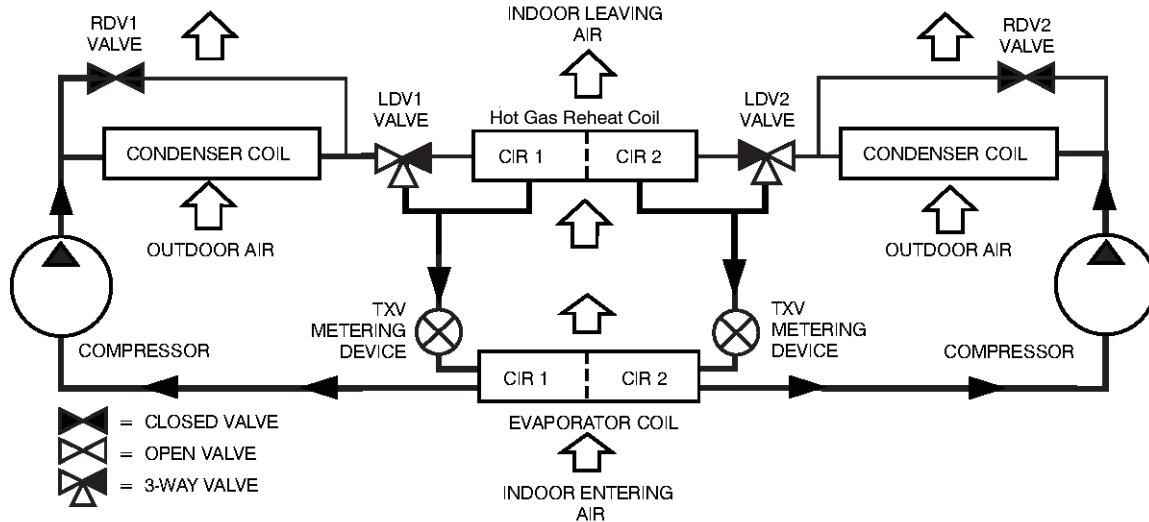

NORMAL COOLING MODE - HOT GAS REHEAT SYSTEM

C12705

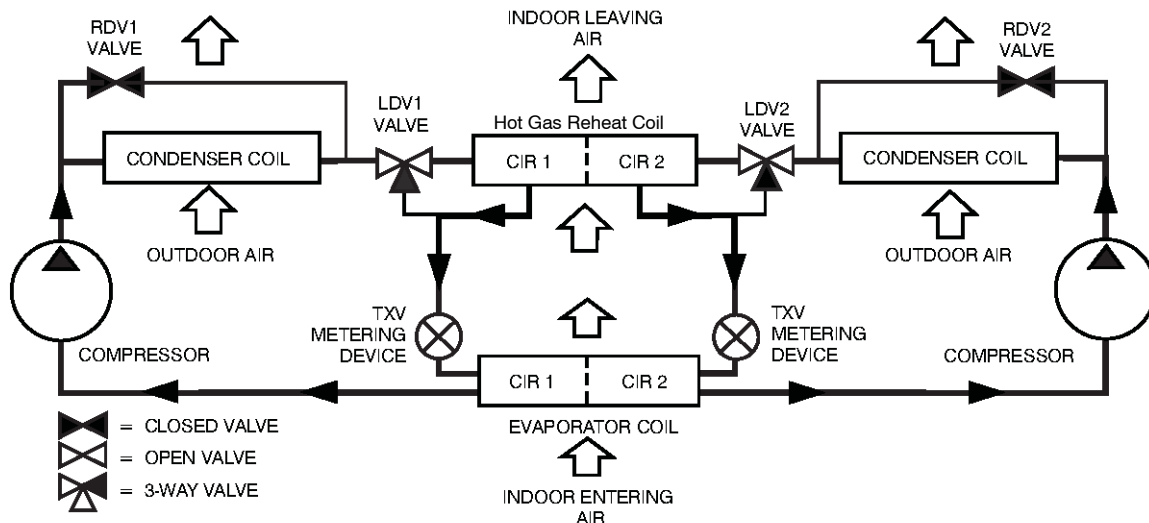

SUBCOOLING MODE (REHEAT 1) - HOT GAS REHEAT SYSTEM

C12706

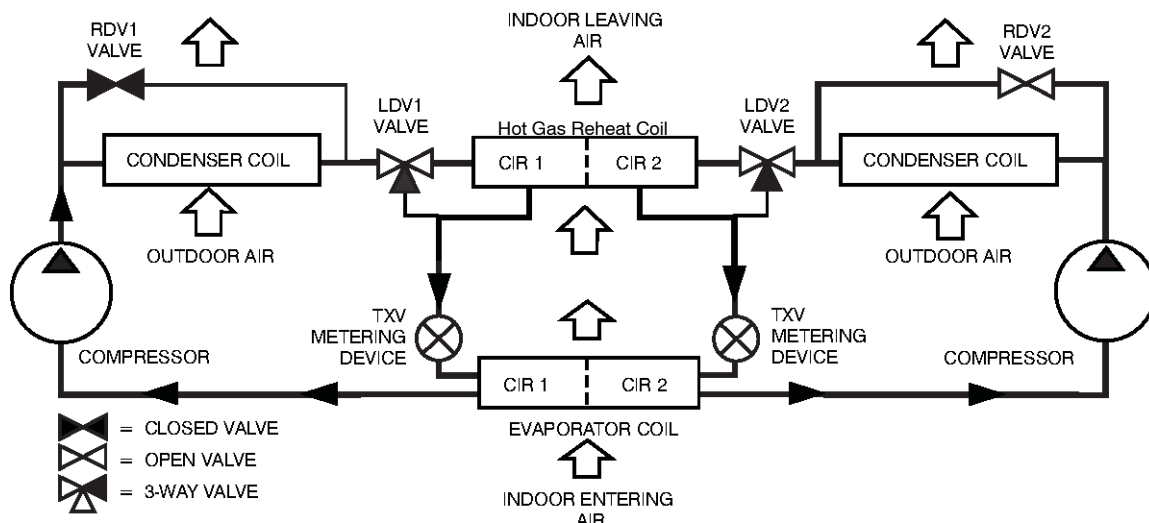

HOT GAS REHEAT (REHEAT 2) - HOT GAS REHEAT SYSTEM

C12707

GUIDE SPECIFICATIONS – RAS210 – 333

Note about this specification:

COOLING ONLY / ELECTRIC HEAT PACKAGED ROOFTOP

HVAC Guide Specifications

Size Range: 17.5 to 27.5 Nominal Tons



Section Description

23 06 80 Schedules for Decentralized HVAC Equipment

23 06 80.13 Decentralized Unitary HVAC Equipment Schedule

23 06 80.13.A. Rooftop unit schedule

1. Schedule is per the project specification requirements.

23 07 16 HVAC Equipment Insulation

23 07 16.13 Decentralized, Rooftop Units:

23 07 16.13.A. Evaporator fan compartment:

1. Interior cabinet surfaces shall be insulated with a minimum 1/2-in. thick, minimum 1 1/2 lb density, flexible fiberglass insulation bonded with a phenolic binder, neoprene coated on the air side.
2. Insulation and adhesive shall meet NFPA 90A requirements for flame spread and smoke generation.

23 07 16.13.B. Electric heat compartment:

1. Aluminum foil-faced fiberglass insulation shall be used.
2. Insulation and adhesive shall meet NFPA 90A requirements for flame spread and smoke generation.

23 09 13 Instrumentation and Control Devices for HVAC

23 09 13.23 Sensors and Transmitters

23 09 13.23.A. Thermostats

1. Thermostat must
 - a. energize both “W” and “G” when calling for heat.
 - b. have capability to energize 2 different stages of cooling, and 2 different stages of heating.
 - c. include capability for occupancy scheduling.

23 09 33 Electric and Electronic Control System for HVAC

23 09 33.13 Decentralized, Rooftop Units:

23 09 33.13.A. General:

1. Shall be complete with self-contained low-voltage control circuit protected by a resettable circuit breaker on the 24-v transformer side. Transformer shall have 75VA capability.
2. Shall utilize color-coded wiring.
3. Shall include a central control terminal board to conveniently and safely provide connection points for vital control functions such as: smoke detectors, phase monitor, economizer, thermostat, and low and high pressure switches.
4. Unit shall include a minimum of one 8-pin screw terminal connection board for connection of control wiring.

23 09 33.23.B. Safeties:

1. Compressor over-temperature, over-current. High internal pressure differential.
2. Low-pressure switch.
 - a. Units shall have different sized connectors for the circuit 1 and circuit 2 low and high pressure switches. They shall physically prevent the cross-wiring of the safety switches between circuits 1 and 2.
 - b. Low pressure switch shall use different color wire than the high pressure switch. The purpose is to assist the installer and service technician to correctly wire and or troubleshoot the rooftop unit.

3. High-pressure switch.
 - a. Units shall have different sized connectors for the circuit 1 and circuit 2 low and high pressure switches. They shall physically prevent the cross-wiring of the safety switches between circuits 1 and 2.
 - b. High pressure switch shall use different color wire than the low pressure switch. The purpose is to assist the installer and service technician to correctly wire and or troubleshoot the rooftop unit.
4. Automatic reset, motor thermal overload protector.

23 09 93 Sequence of Operations for HVAC Controls

23 09 93.13 Decentralized, Rooftop Units:

23 09 93.13 INSERT SEQUENCE OF OPERATION

23 40 13 Panel Air Filters

23 40 13.13 Decentralized, Rooftop Units:

23 40 13.13.A. Standard filter section

1. Shall consist of factory-installed, low velocity, disposable 2-in. thick fiberglass filters of commercially available sizes.
2. Unit shall use only one filter size. Multiple sizes are not acceptable.
3. Filters shall be accessible through a dedicated, weather tight access panel.
4. 4-in filter capabilities shall be capable with pre-engineered and approved filter track field installed accessory. This kit requires field furnished filters.

23 81 19 Self-Contained Air Conditioners

23 81 19.13 Medium-Capacity Self-Contained Air Conditioners (RAS210-303)

23 81 19.13.A. General

1. Outdoor, rooftop mounted, electrically controlled, heating and cooling unit utilizing a fully hermetic scroll compressor(s) for cooling duty and electric heat accessories for heating duty.
2. Factory assembled, single-piece heating and cooling rooftop unit. Contained within the unit enclosure shall be all factory wiring, piping, controls, and special features required prior to field start-up.
3. Unit shall use environmentally sound, R-410A refrigerant.
4. Unit shall be installed in accordance with the manufacturer's instructions.
5. Unit must be selected and installed in compliance with local, state, and federal codes.

23 81 19.13.B. Quality Assurance

1. Unit meets ASHRAE 90.1 minimum efficiency requirements.
2. Units are Energy Star certified where sizes are required.
3. Unit shall be rated in accordance with AHRI Standard 340/360.
4. Unit shall be designed to conform to ASHRAE 15.
5. Unit shall be UL-tested and certified in accordance with ANSI Z21.47 Standards and UL-listed and certified under Canadian standards as a total package for safety requirements.
6. Insulation and adhesive shall meet NFPA 90A requirements for flame spread and smoke generation.
7. Unit casing shall be capable of withstanding 500-hour salt spray exposure per ASTM B117 (scribed specimen).
8. Unit casing shall be capable of withstanding Federal Test Method Standard No. 141 (Method 6061) 5000-hour salt spray.
9. Unit shall be designed in accordance with ISO 9001:2000, and shall be manufactured in a facility registered by ISO 9001:2000.
10. Roof curb shall be designed to conform to NRCA Standards.
11. Unit shall be subjected to a completely automated run test on the assembly line. The data for each unit will be stored at the factory, and must be available upon request.
12. Unit shall be designed in accordance with UL Standard 1995, including tested to withstand rain.
13. Unit shall be constructed to prevent intrusion of snow and tested to prevent snow intrusion into the control box up to 40 mph.
14. Unit shake tested to assurance level 1, ASTM D4169 to ensure shipping reliability.
15. High Efficient Motors listed shall meet section 313 of the Energy Independence and Security Act of 2007 (EISA 2007).

23 81 19.13.C. Delivery, Storage, and Handling

1. Unit shall be stored and handled per manufacturer's recommendations.
2. Lifted by crane requires either shipping top panel or spreader bars.
3. Unit shall only be stored or positioned in the upright position.

23 81 19.13.E. Project Conditions

1. As specified in the contract.

23 81 19.13.F. Operating Characteristics

1. Unit shall be capable of starting and running at 115°F (46°C) ambient outdoor temperature, meeting maximum load criteria of AHRI Standard 340/360 at ± 10% voltage.
2. Compressor with standard controls shall be capable of operation down to 30°F (-1°C), ambient outdoor temperatures. Accessory winter start kit is necessary if mechanically cooling at ambient temperatures below 30°F (-1°C).
3. Unit shall discharge supply air vertically or horizontally as shown on contract drawings.
4. Unit shall be factory configured and ordered for vertical supply & return configurations.
5. Unit shall be factory furnished for either vertical or horizontal configuration without the use of special conversion kits. No field conversion is possible.
6. Unit shall be capable of mixed operation: vertical supply with horizontal return or horizontal supply with vertical return.

23 81 19.13.G. Electrical Requirements

1. Main power supply voltage, phase, and frequency must match those required by the manufacturer.

23 81 19.13.H. Unit Cabinet

1. Unit cabinet shall be constructed of galvanized steel, and shall be bonderized and coated with a pre-painted baked enamel finish on all externally exposed surfaces.
2. Unit cabinet exterior paint shall be: film thickness, (dry) 0.003 inches minimum, gloss (per ASTM D523, 60°F / 16°C): 60, Hardness: H-2H Pencil hardness.
3. Evaporator fan compartment interior cabinet insulation shall conform to AHRI Standard 340/360 minimum exterior sweat criteria. Interior surfaces shall be insulated with a minimum 1/2-in. thick, 1 lb density, flexible fiberglass insulation, neoprene coated on the air side. Aluminum foil-faced fiberglass insulation shall be used in the gas heat compartment.
4. Base of unit shall have a minimum of four locations for thru-the-base electrical connections standard. Electric connections shall be internal to the cabinet to protect from environmental issues.
5. Base Rail
 - a. Unit shall have base rails on a minimum of 2 sides.
 - b. Holes shall be provided in the base rails for rigging shackles to facilitate maneuvering and overhead rigging.
 - c. Holes shall be provided in the base rail for moving the rooftop by fork truck.
 - d. Base rail shall be a minimum of 16 gauge thickness.
6. Condensate pan and connections:
 - a. Shall be a sloped condensate drain pan made of a non-corrosive material.
 - b. Shall comply with ASHRAE Standard 62.
 - c. Shall use a 3/4-in -14 NPT drain connection, through the side of the drain pan. Connection shall be made per manufacturer's recommendations.
7. Top panel:
 - a. Shall be a multi-piece top panel linked with water tight flanges and locking systems.
8. Electrical Connections
 - a. All unit power wiring shall enter unit cabinet at a single, factory-prepared, knockout location.
 - b. Thru-the-base capability.
 - (1.) Standard unit shall have a thru-the-base electrical location(s) using a raised, embossed portion of the unit basepan.
 - (2.) Optional, factory-approved, water-tight connection method must be used for thru-the-base electrical connections.
 - (3.) No basepan penetration, other than those authorized by the manufacturer, is permitted.
9. Component access panels (standard)
 - a. Cabinet panels shall be easily removable for servicing.
 - b. Unit shall have one factory installed, tool-less, removable, filter access panel.
 - c. Panels covering control box and filter shall have molded composite handles while the blower access door shall have an integrated flange for easy removal.
 - d. Handles shall be UV modified, composite. They shall be permanently attached, and recessed into the panel.
 - e. Screws on the vertical portion of all removable access panels shall engage into heat resistant, molded composite collars.

f. Collars shall be removable and easily replaceable using manufacturer recommended parts.

23 81 19.13.J. Coils

1. Standard Aluminum fin – Copper Tube Coils:

- a. Standard evaporator and condenser coils shall have aluminum lanced plate fins mechanically bonded to seamless internally grooved copper tubes with all joints brazed.
- b. Evaporator coils shall be leak tested to 150 psig, pressure tested to 450 psig, and qualified to UL 1995 burst test at 1775 psig.
- c. Condenser coils shall be leak tested to 150 psig, pressure tested to 650 psig, and qualified to UL 1995 burst test at 1980 psig.

2. Optional Pre-coated aluminum–fin condenser coils:

- a. Shall have a durable epoxy–phenolic coating to provide protection in mildly corrosive coastal environments.
- b. Coating shall be applied to the aluminum fin stock prior to the fin stamping process to create an inert barrier between the aluminum fin and copper tube.
- c. Epoxy–phenolic barrier shall minimize galvanic action between dissimilar metals.

3. Optional Copper–fin evaporator and condenser coils:

- a. Shall be constructed of copper fins mechanically bonded to copper tubes and copper tube sheets.
- b. Galvanized steel tube sheets shall not be acceptable.
- c. A polymer strip shall prevent coil assembly from contacting the sheet metal coil pan to minimize potential for galvanic corrosion between coil and pan.

4. Optional E-coated aluminum–fin evaporator and condenser coils:

- a. Shall have a flexible epoxy polymer coating uniformly applied to all coil surface areas without material bridging between fins.
- b. Coating process shall ensure complete coil encapsulation of tubes, fins and headers.
- c. Color shall be high gloss black with gloss per ASTM D523–89.
- d. Uniform dry film thickness from 0.8 to 1.2 mil on all surface areas including fin edges.
- e. Superior hardness characteristics of 2H per ASTM D3363–92A and cross-hatch adhesion of 4B–5B per ASTM D3359–93.
- f. Impact resistance shall be up to 160 in.–lb (ASTM D2794–93).
- g. Humidity and water immersion resistance shall be up to minimum 1000 and 250 hours respectively (ASTM D2247–92 and ASTM D870–92).
- h. Corrosion durability shall be confirmed through testing to be no less than 1000 hours salt spray per ASTM B117–90.

5. Optional E-coated aluminum–fin, aluminum tube condenser coils:

- a. Shall have a flexible epoxy polymer coating uniformly applied to all coil external surface areas without material bridging between fins or louvers.
- b. Coating process shall ensure complete coil encapsulation, including all exposed fin edges.
- c. E-coat thickness of 0.8 to 1.2 mil with top coat having a uniform dry film thickness from 1.0 to 2.0 mil on all external coil surface areas, including fin edges, shall be provided.
- d. Shall have superior hardness characteristics of 2H per ASTM D3363–00 and cross-hatch adhesion of 4B–5B per ASTM D3359–02.
- e. Shall have superior impact resistance with no cracking, chipping or peeling per NSF/ANSI 51–2002 Method 10.2.

23 81 19.13.K. Refrigerant Components

1. Refrigerant circuit shall include the following control, safety, and maintenance features:

- a. Fixed orifice metering system shall prevent mal-distribution of two-phase refrigerant by including multiple fixed orifice devices in each refrigeration circuit. Each orifice is to be optimized to the coil circuit it serves.
- b. Refrigerant filter drier – Solid core design.
- c. Service gauge connections on suction and discharge lines.
- d. Pressure gauge access through a specially designed access screen on the side of the unit.

2. Compressors

- a. Unit shall use fully hermetic, scroll compressor for each independent refrigeration circuit.
- b. Models shall be available with 2 compressor/2 stage cooling and microchannel condenser coils.
- c. Compressor motors shall be cooled by refrigerant gas passing through motor windings.
- d. Compressors shall be internally protected from high discharge temperature conditions.

- e. Compressors shall be protected from an over-temperature and over-ampereage conditions by an internal, motor overload device.
- f. Compressor shall be factory mounted on rubber grommets.
- g. Compressor motors shall have internal line break thermal, current overload and high pressure differential protection.
- h. Crankcase heaters shall not be required for normal operating range, unless provided by the factory.

23 81 19.13.L. Filter Section

- 1. Filters access is specified in the unit cabinet section of this specification.
- 2. Filters shall be held in place by a preformed, slide-out filter tray, facilitating easy removal and installation.
- 3. Shall consist of factory-installed, low velocity, throw-away 2-in. thick fiberglass filters.
- 4. Filters shall be standard, commercially available sizes.
- 5. Only one size filter per unit is allowed.
- 6. 4-in filter capability is possible with a field installed pre engineered slide out filter track accessory. 4-in filters are field furnished.

23 81 19.13.M. Evaporator Fan and Motor

- 1. Evaporator fan motor:
 - a. Shall have inherent automatic-reset thermal overload protection or circuit breaker.
 - b. Shall have a maximum continuous bhp rating for continuous duty operation; no safety factors above that rating shall be required.
- 2. Belt-driven Evaporator Fan:
 - a. Belt drive shall include an adjustable-pitch motor pulley and belt break protection system.
 - b. Shall use rigid pillow block bearing system with lubricant fittings at accessible bearing or lubrication line.
 - c. Blower fan shall be double-inlet type with forward-curved blades.
 - d. Shall be constructed from steel with a corrosion resistant finish and dynamically balanced.

23 81 19.13.N. Condenser Fans and Motors

- 1. Condenser fan motors:
 - a. Shall be a totally enclosed motor.
 - b. Shall use permanently lubricated bearings.
 - c. Shall have inherent thermal overload protection with an automatic reset feature.
 - d. Shall use a shaft-down design.
- 2. Condenser Fans:
 - a. Shall be a direct-driven propeller type fan.
 - b. Shall have aluminum blades riveted to corrosion-resistant steel spiders and shall be dynamically balanced.

23 81 19.13.O. Special Features Options and Accessories

- 1. 2-speed indoor fan motor for 2-stage cooling models only
 - a. Evaporator fan motor:
 - (1.) Shall have permanently lubricated bearings.
 - (2.) Shall have a maximum continuous bhp rating for continuous duty operation; no safety factors above that rating.
 - (3.) Shall be Variable Frequency duty and 2-speed control.
 - (4.) Shall contain motor shaft grounding ring to prevent electrical bearing fluting damage by safely diverting harmful shaft voltages and bearing currents to ground.
- 2. Variable Frequency Drive (VFD). Only available on 2-speed indoor fan motor option:
 - a. Shall be installed inside the unit cabinet, mounted, wired and tested.
 - b. Shall contain Electromagnetic Interference (EMI) frequency protection.
 - c. Insulated Gate Bi-Polar Transistors (IGBT) used to produce the output pulse width modulated (PWM) waveform, allowing for quiet motor operation.
 - d. Self diagnostics with fault and power code LED indicator. Field accessory Display Kit available for further diagnostics and special setup applications.
 - e. RS485 capability standard.
 - f. Electronic thermal overload protection.
 - g. 5% swinging chokes for harmonic reduction and improved power factor.
 - h. All printed circuit boards shall be conformal coated.

3. Standard Integrated Economizers (Factory installed on 3 Phase Models Only. Field installed on all 3 and 1 Phase Models):
 - a. Integrated, gear-driven opposing blade design type capable of simultaneous economizer and compressor operation.
 - b. Independent modules for vertical or horizontal return configurations shall be available. Vertical and horizontal return modules shall be available as a factory installed option.
 - c. Damper blades shall be galvanized steel with composite gears. Plastic or composite blades on intake or return shall not be acceptable.
 - d. Shall include all hardware and controls to provide free cooling with outdoor air when temperature and/or humidity are below setpoints.
 - e. Shall be equipped with gear driven dampers for both the outdoor ventilation air and the return air for positive air stream control.
 - f. Standard models shall be equipped with low-leakage dampers, not to exceed 2% leakage at 1 in. wg pressure differential. Economizer controller on electromechanical units shall be Honeywell W7212 that provides:
 - (1.) Combined minimum and DCV maximum damper position potentiometers with compressor staging relay.
 - (2.) Functions with solid state analog enthalpy or dry bulb changeover control sensing.
 - (3.) Contain LED indicates for:
 - When free cooling is available
 - When module is in DCV mode
 - When exhaust fan contact is closed
 - g. Ultra low leak EconoMi\$er X system shall be available on models with 2-speed indoor fan motor 2-speed Variable Frequency Drive (VFD) systems. Only available on 2-Speed Indoor Fan Motor Systems with electromechanical controls or RTU Open.
 - (1.) Maximum damper leakage rate to be equal to or less than 4.0 cfm/sq. ft. at 1.0 in. w.g., meeting or exceeding ASHRAE 90.1 requirements. Economizer controller on electromechanical units shall be Honeywell W7220 that provides:
 - (2.) 2-line LCD interface screen for setup, configuration and troubleshooting.
 - (3.) On-board fault detection and diagnostics
 - (4.) Sensor failure loss of communication identification
 - (5.) Automatic sensor detection
 - (6.) Capabilities for use with multiple-speed indoor fan systems
 - (7.) Utilize digital sensors: Dry bulb and Enthalpy
 - h. Shall be capable of introducing up to 100% outdoor air.
 - i. Shall be equipped with a barometric relief damper capable of relieving up to 100% return air.
 - j. Shall be designed to close damper(s) during loss-of-power situations with spring return built into motor.
 - k. Dry bulb outdoor air temperature sensor shall be provided as standard. Outdoor air sensor setpoint shall be adjustable and shall range from 40 to 100°F / 4 to 38°C. Additional sensor options shall be available as accessories.
 - l. The economizer controller shall also provide control of an accessory power exhaust unit function. Factory set at 100%, with a range of 0% to 100%.
 - m. The economizer shall maintain minimum airflow into the building during occupied period and provide design ventilation rate for full occupancy. A remote potentiometer may be used to override the damper setpoint.
 - n. Dampers shall be completely closed when the unit is in the unoccupied mode.
 - o. Economizer controller shall accept a 2-10 Vdc CO₂ sensor input for IAQ/DCV control. In this mode, dampers shall modulate the outdoor air damper to provide ventilation based on the sensor input.
 - p. Compressor lockout sensor shall open at 35°F (2°C) and close closes at 50°F (10°C).
 - q. Actuator shall be direct coupled to economizer gear. No linkage arms or control rods shall be acceptable.
 - r. Economizer controller shall provide indications when in free cooling mode, in the DCV mode, or the exhaust fan contact is closed.
4. Two-Position Motorized Damper (Factory installed on 3 Phase Models Only. Field installed on all 3 and 1 Phase Models)
 - a. Damper shall be a Two-Position Damper. Damper travel shall be from the full closed position to the field adjustable %-open setpoint.
 - b. Damper shall include adjustable damper travel from 25% to 100% (full open).
 - c. Damper shall include single or dual blade, gear driven dampers and actuator motor.
 - d. Actuator shall be direct coupled to damper gear. No linkage arms or control rods shall be acceptable.

- e. Damper will admit up to 100% outdoor air for applicable rooftop units.
 - f. Damper shall close upon indoor (evaporator) fan shutoff and/or loss of power.
 - g. The damper actuator shall plug into the rooftop unit's wiring harness plug. No hard wiring shall be required.
 - h. Outside air hood shall include aluminum water entrainment filter
5. Manual damper
- a. Manual damper package shall consist of damper, air inlet screen, and rain hood which can be preset to admit up to 25% outdoor air for year round ventilation.
6. Hot Gas Reheat System (3 Phase Models only)
- a. The Hot Gas Reheat System shall be factory-installed in 2-stage RAS models with RTPF (round tube plate fin) condenser coils, and shall provide greater dehumidification of the occupied space by two modes of dehumidification operations beside its normal design cooling mode:
 - (1.) Subcooling mode further subcools the hot liquid refrigerant leaving the condenser coil when both temperature and humidity in the space are not satisfied.
 - (2.) Hot gas reheat mode shall mix a portion of the hot gas from the discharge of the compressor with the hot liquid refrigerant leaving the condenser coil to create a two-phase heat transfer in the system, resulting in a neutral leaving-air temperature when only humidity in the space is not satisfied.
 - (3.) Includes Head Pressure Controller.
7. Head Pressure Control Package
- a. Controller shall control coil head pressure by condenser-fan speed modulation or condenser-fan cycling and wind baffles.
 - b. Shall consist of solid-state control and condenser-coil temperature sensor to maintain condensing temperature between 90°F (32°C) and 110°F (43°C) at outdoor ambient temperatures down to -20°F (-29°C).
8. Condenser Coil Hail Guard Assembly
- a. Shall protect against damage from hail.
 - b. Shall be louvered style design.
9. Unit-Mounted, Non-Fused Disconnect Switch:
- a. Switch shall be factory-installed, internally mounted.
 - b. National Electric Code (NEC) and ETL approved non-fused switch shall provide unit power shutoff.
 - c. Shall be accessible from outside the unit
 - d. Shall provide local shutdown and lockout capability.
10. Convenience Outlet:
- a. Non-Powered convenience outlet.
 - (1.) Outlet shall be powered from a separate 115/120v power source.
 - (2.) A transformer shall not be included.
 - (3.) Outlet shall be factory-installed and internally mounted with easily accessible 115-v female receptacle.
 - (4.) Outlet shall include 15 amp GFI receptacles with independent fuse protection.
 - (5.) Outlet shall be accessible from outside the unit.
 - (6.) Outlet shall include a field-installed "Wet in Use" cover.
11. Fan/Filter Status Switch:
- a. Switch shall provide status of indoor evaporator fan (ON/OFF) or filter (CLEAN/DIRTY).
 - b. Status shall be displayed either over communication bus (when used with direct digital controls) or with an indicator light at the thermostat.
12. Centrifugal Power Exhaust:
- a. Power exhaust shall be used in conjunction with an integrated economizer.
 - b. Independent modules for vertical or horizontal return configurations shall be available.
 - c. Horizontal power exhaust is shall be mounted in return ductwork.
 - d. Power exhaust shall be controlled by economizer controller operation. Exhaust fans shall be energized when dampers open past the 0-100% adjustable setpoint on the economizer control.
13. Roof Curbs (Vertical):
- a. Full perimeter roof curb with exhaust capability providing separate air streams for energy recovery from the exhaust air without supply air contamination.
 - b. Formed galvanized steel with wood nailer strip and shall be capable of supporting entire unit weight.
 - c. Permits installation and securing of ductwork to curb prior to mounting unit on the curb.
14. High-Static Indoor Fan Motor(s) and Drive(s):
- a. High-static motor(s) and drive(s) shall be factory-installed to provide additional performance range.

15. Outdoor Air Enthalpy Sensor:
 - a. The outdoor air enthalpy sensor shall be used to provide single enthalpy control. When used in conjunction with a return air enthalpy sensor, the unit will provide differential enthalpy control. The sensor allows the unit to determine if outside air is suitable for free cooling.
16. Return Air Enthalpy Sensor:
 - a. The return air enthalpy sensor shall be used in conjunction with an outdoor air enthalpy sensor to provide differential enthalpy control.
17. Indoor Air Quality (CO₂) Sensor:
 - a. Shall be able to provide demand ventilation indoor air quality (IAQ) control.
 - b. The IAQ sensor shall be available in duct mount. The setpoint shall have adjustment capability.
18. Smoke detectors (Supply):
 - a. Shall be a Four-Wire Controller and Detector.
 - b. Shall be environmental compensated with differential sensing for reliable, stable, and drift-free sensitivity.
 - c. Shall use magnet-activated test/reset sensor switches.
 - d. Shall have tool-less connection terminal access.
 - e. Shall have a recessed momentary switch for testing and resetting the detector.
 - f. Controller shall include:
 - (1.) One set of normally open alarm initiation contacts for connection to an initiating device circuit on a fire alarm control panel.
 - (2.) Two Form-C auxiliary alarm relays for interface with rooftop unit or other equipment.
 - (3.) One Form-C supervision (trouble) relay to control the operation of the Trouble LED on a remote test/reset station.
 - (4.) Capable of direct connection to two individual detector modules.
 - (5.) Can be wired to up to 14 other duct smoke detectors for multiple fan shutdown applications
19. Winter start kit
 - a. Shall contain a bypass device around the low pressure switch.
 - b. Shall be required when mechanical cooling is required down to 25°F (-4°C).
 - c. Shall not be required to operate on an economizer when below an outdoor ambient of 40°F (4°C).
20. Time Guard
 - a. Shall prevent compressor short cycling by providing a 5-minute delay (±2 minutes) before restarting a compressor after shutdown for any reason.
 - b. One device shall be required per compressor.
21. Electric Heat:
 - a. Heating Section
 - (1.) Heater element open coil resistance wire, nickel-chrome alloy, 0.29 inches inside diameter, strung through ceramic insulators mounted on metal frame. Coil ends are staked and welded to terminal screw slots.
 - (2.) Heater assemblies are provided with integral fusing for protection of internal heater circuits not exceeding 48 amps each. Auto reset thermo limit controls, magnetic heater contactors (24 v coil) and terminal block all mounted in electric heater control box (minimum 18 ga galvanized steel) attached to end of heater assembly.
22. Barometric Hood (Horizontal Economizer Applications)
 - a. Shall be required when a horizontal economizer and barometric relief are required. Barometric relief damper must be installed in the return air (horizontal) duct work. This hood provides weather protection.
23. Display Kit for Variable Frequency Drive
 - a. Kit allows the ability to access the VFD controller programs to provide special setup capabilities and diagnostics.
 - b. Kit contains display module, mounting bracket and communication cable.
 - c. Display Kit can be permanently installed in the unit or used on any 2-Speed Indoor Fan Motor VFD controller as needed.