

INSTALLATION INSTRUCTIONS

R-410A Heat Pump Condensing Units

CHS180 - 240

These instructions must be read and understood completely before attempting installation

Safety Labeling and Signal Words

DANGER, WARNING, CAUTION, and NOTE

The signal words **DANGER**, **WARNING**, **CAUTION**, and **NOTE** are used to identify levels of hazard seriousness. The signal word **DANGER** is only used on product labels to signify an immediate hazard. The signal words **WARNING**, **CAUTION**, and **NOTE** will be used on product labels and throughout this manual and other manual that may apply to the product.

DANGER - Immediate hazards which will result in severe personal injury or death.

WARNING - Hazards or unsafe practices which could result in severe personal injury or death.

CAUTION - Hazards or unsafe practices which may result in minor personal injury or product or property damage.

NOTE - Used to highlight suggestions which will result in enhanced installation, reliability, or operation.

Signal Words in Manuals

The signal word **WARNING** is used throughout this manual in the following manner:

 **WARNING**

The signal word **CAUTION** is used throughout this manual in the following manner:

 **CAUTION**

Signal Words on Product Labeling

Signal words are used in combination with colors and/or pictures or product labels.

TABLE OF CONTENTS

MODEL NOMENCLATURE	2
SAFETY CONSIDERATIONS	2
INSTALLATION GUIDELINE	3
INSTALLATION	8
Step 1 - Plan for Unit Location	8
Step 2 - Complete Pre-Installation Checks	8
Step 3 - Prepare Unit Mounting Support	9
Step 4 - Rig and Mount the Unit	9
Step 5 - Complete Refrigerant Piping Connections	9
Step 6 - Install Accessories	13
Step 7 - Complete Electrical Connections	13
PRE-START-UP	18
START-UP	18
OPERATING SEQUENCE	29
ROUTINE SYSTEM MAINTENANCE	30
SERVICE	30
TROUBLESHOOTING	42
START-UP CHECKLIST	51

 **WARNING**

PERSONAL INJURY, AND/OR PROPERTY DAMAGE HAZARD

Failure to carefully read and follow this warning could result in equipment malfunction, property damage, personal injury and/or death.

Installation or repairs made by unqualified persons could result in equipment malfunction, property damage, personal injury and/or death.

The information contained in this manual is intended for use by a qualified service technician familiar with safety procedures and equipped with proper tools and test instruments.

Installation must conform with local building codes and with the national Electrical Code NFPA70 current edition or Canadian Electrical Code part 1 CSA C.22.1.

MODEL NOMENCLATURE

MODEL SERIES	C	H	S	1	8	0	H	A	A	0	A	0	0	A
Position Number	1	2	3	4	5	6	7	8	9	10	11	12	13	14
C = R-410A Condensing Unit														
A = Air Conditioning (Cooling Only)														
H = Heat Pump														
Type														
S = Standard ASHRAE 90.1-2010 Efficiency														
Efficiency														
180 = 180,000 BTUH = 15 Tons (2 circuit)														
240 = 240,000 BTUH = 20 Tons (2 circuit)														
Nominal Cooling Capacity														
H = 208/230-3-60														
L = 460-3-60														
S = 575-3-60														
Voltage														
D = Dual Circuit														
E = Dual Circuit w/ Low Ambient Control														
Refrigerant System Options														
A = Cu/Al Cond. RTPF														
Outdoor Coil Options														
0 = None														
1 = Non-powered 115v Convenience Outlet														
Service Options														
A = None														
C = Non-Fused Disconnect Switch														
Electrical Options														
0 = Standard Elec-Mechanical Control														
Base Unit Controls														
0 = No options, reserved for future Use														
Future Use														
A = Original Design														
Sales Digit														

SAFETY CONSIDERATIONS

Improper installation, adjustment, alteration, service, maintenance, or use can cause explosion, fire, electrical shock or other conditions which may cause personal injury or property damage. Consult a qualified installer, service agency, or your distributor or branch for information or assistance. The qualified installer or agency must use factory-authorized kits or accessories when modifying this product. Refer to the individual instructions packaged with the kits or accessories when installing.

Follow all safety codes. Wear safety glasses and work gloves. Use quenching cloths for brazing operations and have a fire extinguisher available. Read these instructions thoroughly and follow all warnings or cautions attached to the unit. Consult local building codes and appropriate national electrical codes (in USA, ANSI/NFPA70, National Electrical Code (NEC); in Canada, CSA C22.1) for special requirements.

Recognize safety information. This is the safety-alert symbol. When you see this symbol in instructions or manuals, be alert to the potential for personal injury.

Understand the signal words **DANGER**, **WARNING**, **CAUTION**, and **NOTE**. These words are used with the

safety-alert symbol. **DANGER** identifies the most serious hazards which **will** result in serious injury or death. **WARNING** signifies a hazard which **could** result in serious injury or death. **CAUTION** is used to identify unsafe practices which **may** result in minor personal injury or product and property damage. **NOTE** is used to highlight suggestions which **will** result in enhanced installation, reliability, or operation.

These instructions cover minimum requirements and conform to existing national standards and safety codes. In some instances, these instructions exceed certain local codes and ordinances, especially those that may not have kept up with changing residential construction practices. We require these instructions as a minimum for a safe installation.

WARNING

ELECTRICAL SHOCK HAZARD

Failure to follow this warning could cause personal injury or death.

Before performing service or maintenance operations on unit, always turn off main power switch to unit and install lockout tag. Unit may have more than one power switch.

⚠ WARNING

UNIT OPERATION AND SAFETY HAZARD

Failure to follow this warning could cause personal injury, death and/or equipment damage.

R-410A refrigerant systems operate at higher pressures than standard R-22 systems. Do not use R-22 service equipment or components on R-410A refrigerant equipment.

⚠ WARNING

PERSONAL INJURY AND ENVIRONMENTAL HAZARD

Failure to follow this warning could cause personal injury, or death.

Relieve pressure and recover all refrigerant before system repair or final unit disposal.

Wear safety glasses and gloves when handling refrigerants. Keep torches and other ignition sources away from refrigerants and oils.

⚠ CAUTION

CUT HAZARD

Failure to follow this caution may result in damage personal injury.

Sheet metal parts may have sharp edges or burrs. Use care and wear appropriate protective clothing, safety glasses and gloves when handling parts and servicing heat pump units.

INSTALLATION GUIDELINE

Replacement /Retrofit – R22 to R-410A

Split system heat pumps are intended to be installed with matching indoor sections only. The CHS heat pump outdoor units are matched only with same-size FHS indoor sections. Existing R-22 indoor coils cannot be converted to R-410A heat pump duty. Only the existing refrigerant piping is a candidate for retrofit use.

Acid test – If the existing system is being replaced because of a compressor electrical failure, assume acid is in system.

If system is being replaced for any other reason, use an approved acid test kit to determine acid level. If even low levels of acid are detected, install a 100 percent activated alumina suction line filter drier in addition to the replacement liquid-line filter drier. Operate this system in COOLING ONLY. Remove the suction line filter drier as soon as possible, with a maximum of 72 hr of operation.

Recommendation: Install a ball valve in the liquid line at the filter drier location when installing a suction filter in the suction line.

Installation –

1. Remove the existing evaporator coil or fan coil and install the replacement coil.
2. Drain oil from low points and traps in suction line tubing if they were not replaced.
3. Remove the existing outdoor unit. Install the new outdoor unit according to these installation instructions.
4. Install the factory-supplied liquid-line filter drier at the indoor coil just upstream of the TXV.

⚠ CAUTION

UNIT DAMAGE HAZARD



Failure to follow this caution may result in equipment damage or improper operation.

Never install suction-line filter drier in the liquid-line of a R-410A system.

5. If required, install a 100% activated alumina suction line filter drier at the outdoor unit.
6. Evacuate and charge the system according to the instructions in this installation manual.
7. Operate the system for 10 hours. Monitor the pressure drop across the suction line filter drier. If pressure drop exceeds 3 psig (21kPa), replace suction-line and liquid-line filter driers. Be sure to purge system with dry nitrogen and evacuate when replacing filter driers. Continue to monitor the pressure drop across suction-line filter drier. Repeat filter changes is necessary. Never leave suction-line filter drier in system longer than 72 hr (actual time).

FIGURE 1 - CHS180 DIMENSIONS

Unit	Std. Unit Weight		Corner A		Corner B		Corner C		Corner D		Center of Gravity			Unit Height
	lbs.	kg	lbs.	kg	lbs.	kg	lbs.	kg	lbs.	kg	X	Y	Z	H
CHS180	768	348	236	107	183	83	153	69	196	89	39 (991)	20 (508)	23 (584)	50-38 (1279)

 CENTER OF GRAVITY
 DIRECTION OF AIR FLOW
 DIMENSIONS IN [] ARE IN MM

Unit	Service Valve Connections		
	Suction	Liquid	QTY
CHS180	1-3/8 (34.9)	1/2 (12.7)	2 ea

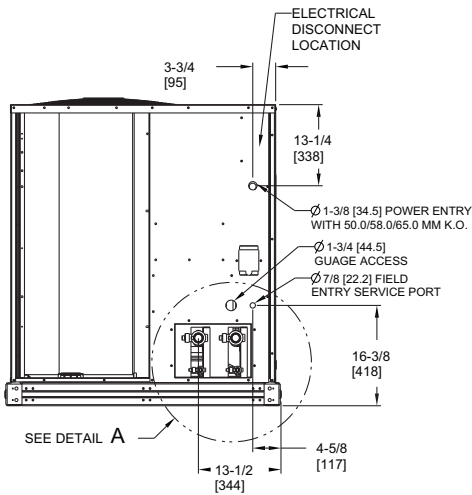
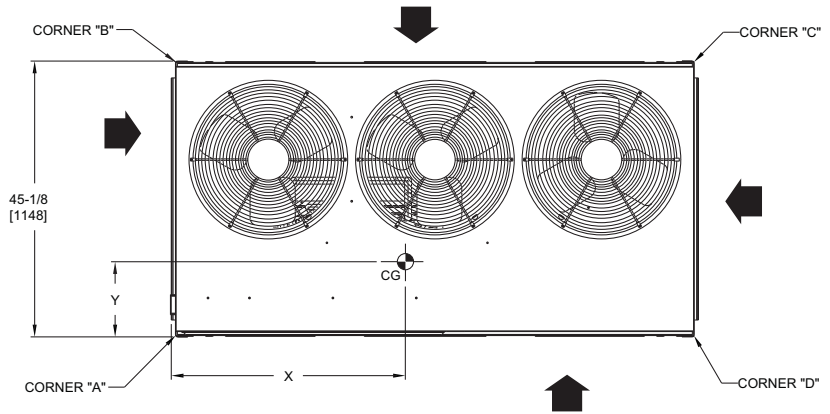

LEFT SIDE VIEW

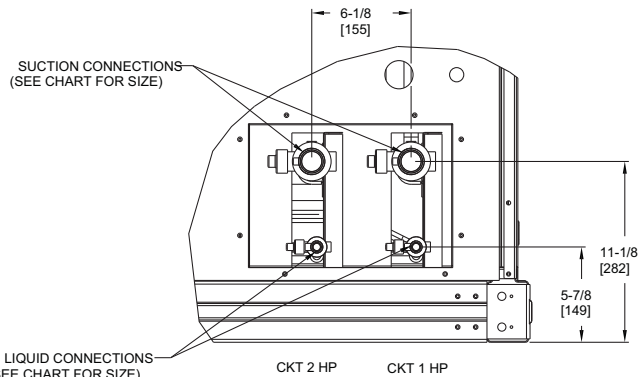
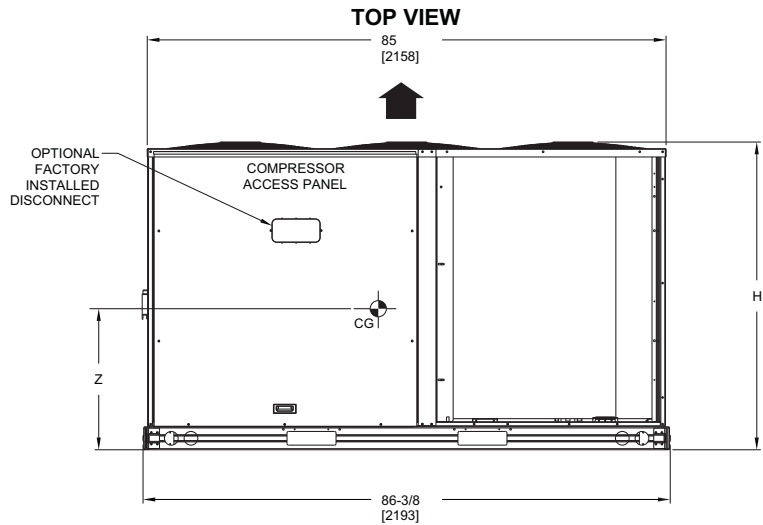



DETAIL A
(NOTE POSITION OF CKT 1)

- NOTES:**
- MINIMUM CLEARANCE (LOCAL CODES OR JURISDICTION MAY PREVAIL):
 - A. BOTTOM TO COMBUSTIBLE SURFACES: 0 INCHES.
 - B. OUTDOOR COIL, FOR PROPER AIR FLOW: 36 INCHES ONE SIDE, 12 INCHES THE OTHER. THE SIDE GETTING THE GREATER CLEARANCE IS OPTIONAL.
 - C. OVERHEAD: 60 INCHES, TO ASSURE PROPER OUTDOOR FAN OPERATION.
 - D. BETWEEN UNITS: CONTROL BOX SIDE, 42 INCHES PER NEC.
 - E. BETWEEN UNIT AND UNGROUNDED SURFACES: CONTROL BOX SIDE, 36 INCHES PER NEC.
 - F. BETWEEN UNIT AND BLOCK OR CONCRETE WALLS AND OTHER GROUNDED SURFACES: CONTROL BOX SIDE, 42 INCHES PER NEC.
 - WITH EXCEPTION OF THE CLEARANCE FOR THE OUTDOOR COIL AS STATED IN NOTE 1B, A REMOVABLE FENCE OR BARRICADE REQUIRES NO CLEARANCE.
 - UNITS MAY BE INSTALLED ON COMBUSTIBLE FLOORS MADE FROM WOOD OR CLASS A, B OR C ROOF COVERING MATERIAL.

C101281

FIGURE 2 - CHS240 DIMENSIONS

Unit	Std. Unit Weight		Corner A		Corner B		Corner C		Corner D		Center of Gravity			Unit Height
	lbs.	kg	lbs.	kg	lbs.	kg	lbs.	kg	lbs.	kg	X	Y	Z	H
CHS240	1015	460	354	161	224	102	170	77	268	122	37 (940)	26 (660)	23 (584)	50-3/8 (1279)

 CENTER OF GRAVITY
 DIRECTION OF AIR FLOW
 DIMENSIONS IN [] ARE IN MM

Unit	Service Valve Connections		
	Suction	Liquid	QTY
CHS240	1-3/8 (34.9)	1/2 (12.7)	2 ea

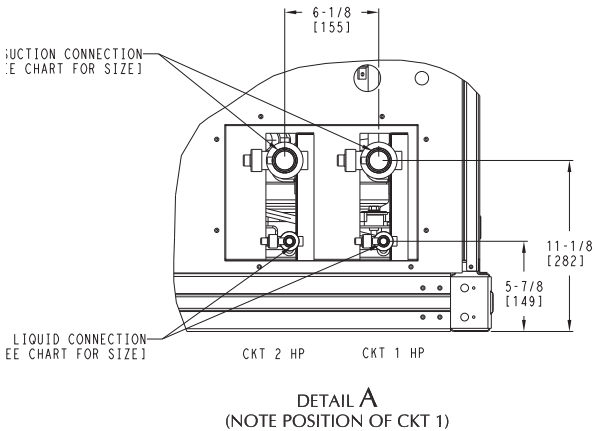
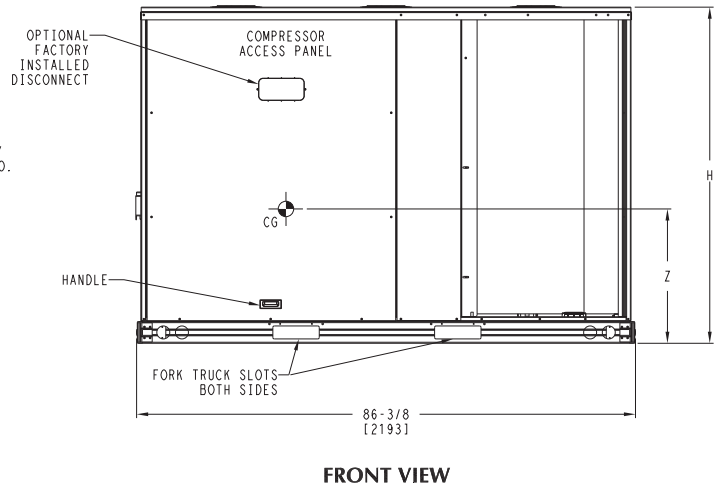
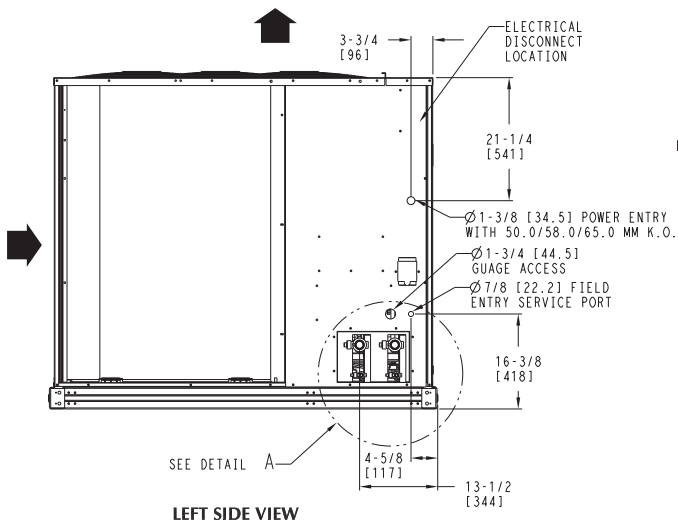
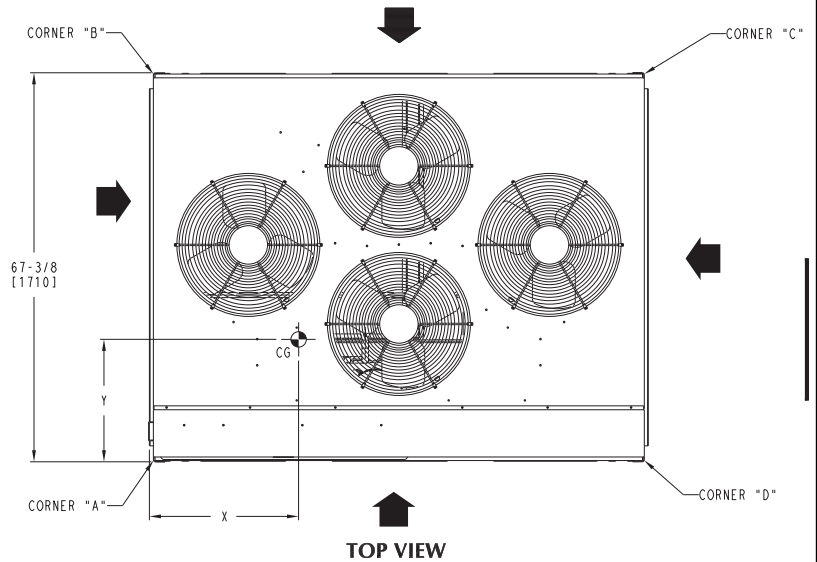

- NOTES:
- MINIMUM CLEARANCE (LOCAL CODES OR JURISDICTION MAY PREVAIL):
 - BOTTOM TO COMBUSTIBLE SURFACES: 0 INCHES.
 - OUTDOOR COIL, FOR PROPER AIR FLOW: 36 INCHES ONE SIDE, 12 INCHES THE OTHER. THE SIDE GETTING THE GREATER CLEARANCE IS OPTIONAL.
 - OVERHEAD: 60 INCHES, TO ASSURE PROPER OUTDOOR FAN OPERATION.
 - BETWEEN UNITS: CONTROL BOX SIDE, 42 INCHES PER NEC.
 - BETWEEN UNIT AND UNGROUNDED SURFACES: CONTROL BOX SIDE, 36 INCHES PER NEC.
 - BETWEEN UNIT AND BLOCK OR CONCRETE WALLS AND OTHER GROUNDED SURFACES: CONTROL BOX SIDE, 42 INCHES PER NEC.
 - WITH EXCEPTION OF THE CLEARANCE FOR THE OUTDOOR COIL AS STATED IN NOTE 1B, A REMOVABLE FENCE OR BARRICADE REQUIRES NO CLEARANCE.
 - UNITS MAY BE INSTALLED ON COMBUSTIBLE FLOORS MADE FROM WOOD OR CLASS A, B OR C ROOF COVERING MATERIAL.

C101282

Table 1A — Physical Data — CHS180-240 Units — 60 Hz English

UNIT SIZE CHS	180	240
NOMINAL CAPACITY (tons)	15	20
REFRIGERANT SYSTEM[‡]	R-410A	
Refrigerant	R-410A	
# Circuits / # Compressor / Type	2 / 2 / Scroll	2 / 2 / Scroll
Shipping Charge A/B (lb)	9.0/9.0	9.0/9.0
Operating Charge w/Fan Coil[†] A/B (lbs)	21/21	27/27
Metering Device	Fixed Orifice	
High-Pressure Trip / Reset (psig)	630 / 505	630 / 505
Low-Pressure Trip / Reset (psig)	27 / 44	27 / 44
COMPRESSOR		
Model	ZP83 (2)	ZP103 (2)
Oil Charge A/B (oz)	60	110
Speed (RPM)	3500	3500
OUTDOOR COIL		
Material	Al/Cu	
Coil Type	Round Tube/Plate Fin (RTPF)	
Rows/Fins Per Inch (FPI)	2/17	
Total Face Area (ft²)	47.1	50.1
OUTDOOR FAN / MOTOR		
Qty / Motor Drive Type	3 / Direct	4 / Direct
Motor HP / RPM	1/4 / 1100	1/4 / 1100
Diameter (in)	22	22
Nominal Airflow (Cfm)	10,000	14,000
Watts (Total)	970	1150
Cut-in	44 ±5	44 ±5
PIPING CONNECTIONS (in. ODS)		
Qty...Vapor	2...1 ³ / ₈	2...1 ³ / ₈
Qty...Liquid	2...1 ¹ / ₂	2...1 ¹ / ₂
LEGEND		
ODS — Outside Diameter Sweat (socket)		
[†] Approximate system charge with 25 ft piping of sizes indicated with matched FHS		

Table 1B — Physical Data — CHS180-240 Units — 60 Hz SI

UNIT SIZE CHS	180	240
NOMINAL CAPACITY (kW)	15	20
REFRIGERANT SYSTEM[‡]	R-410A	
Refrigerant	R-410A	
# Circuits / # Compressor / Type	2 / 2 / Scroll	2 / 2 / Scroll
Shipping Charge A/B (kg)	4.1/4.1	4.1/4.1
Operating Charge w/Fan Coil[†] A/B (kg)	9.5/9.5	12.2/12.2
Metering Device	Fixed Orifice	
High-Pressure Trip / Reset (kPa)	4344 / 3482	4344 / 3482
Low-Pressure Trip / Reset (kPa)	372 / 807	372 / 807
COMPRESSOR		
Model	ZP83 (2)	ZP103 (2)
Oil Charge A/B (L)	1.7	3.2
Speed (r/s)	58	58
OUTDOOR COIL		
Material	Al/Cu	
Coil Type	Round Tube/Plate Fin (RTPF)	
Rows/Fins Per Meter (Fins/m)	2/17	
Total Face Area (m²)	4.4	4.6
OUTDOOR FAN / MOTOR		
Qty / Motor Drive Type	3 / Direct	4 / Direct
Motor HP / r/s	1/4 / 18	1/4 / 18
Diameter (mm)	559	559
Nominal Airflow (L/s)	4719	6607
Watts (Total)	970	1150
Cut-in	44 ±5	44 ±5
PIPING CONNECTIONS (mm ODS)		
Qty / Vapor	2 / 34.9	2 / 34.9
Qty / Liquid	2 / 12.7	2 / 12.7
LEGEND		
NEMA — National Electrical Manufacturers Association		
ODS — Outside Diameter Sweat (socket)		
† Approximate system charge with 7.6 m piping of sizes indicated with matched FHS		

INSTALLATION

Jobsite Survey

Complete the following checks before installation.

1. Consult local building codes and the NEC (National Electrical Code) ANSI/NFPA 70 for special installation requirements.
2. Determine unit location (from project plans) or select unit location.
3. Check for possible overhead obstructions which may interfere with unit lifting or rigging.

Step 1 — Plan for Unit Location

Select a location for the unit and its support system (pad, rails or other) that provides for the minimum clearances required for safety. This includes the clearance to combustible surfaces, unit performance and service access below, around and above unit as specified in unit drawings. See Fig. 3.

Select a unit mounting system that provides adequate height to allow for removal and disposal of frost and ice that will form during the heating-defrost mode.

NOTE: Consider also the effect of adjacent units on airflow performance and control box safety clearance.

Do not install the outdoor unit in an area where fresh air supply to the outdoor coil may be restricted or when recirculation from the condenser fan discharge is possible. Do not locate the unit in a well or next to high walls.

Evaluate the path and required line length for interconnecting refrigeration piping, including suction riser requirements (outdoor unit above indoor unit), liquid line lift (outdoor unit below indoor unit) and hot gas bypass line. Relocate sections to minimize the length of interconnecting tubing.

DO NOT BURY REFRIGERATION LINES.

Although unit is weatherproof, avoid locations that permit water from higher level runoff and overhangs to fall onto the unit.

FIGURE 3 - Service Clearance Dimensional Drawing

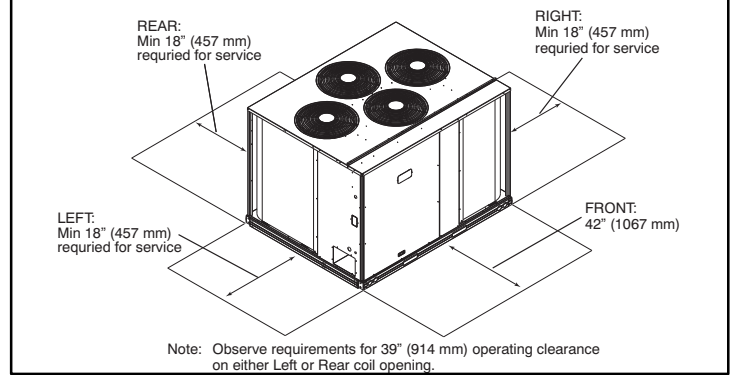

Step 2 — Complete Pre-Installation Checks

Check Unit Electric Characteristic —

Confirm before installation of unit that voltage, amperage and circuit protection requirements listed on unit data plate agree with power supply provided.

Un-crate Unit —

Remove unit packaging except for the top skid assembly, which should be left in place until after the unit is rigged into its final location.

Inspect Shipment —

File a claim with shipping company if the shipment is damaged or incomplete.

Consider System Requirements —

- Consult local building codes and National Electrical Code (NEC, U.S.A.) for special installation requirements.
- Allow sufficient space for airflow clearance, wiring, refrigerant piping, and servicing unit. See Figs. 1 and 2 for unit dimensions and weight distribution data.
- Locate the unit so that the outdoor coil (condenser) airflow is unrestricted on all sides and above.

- The unit may be mounted on a level pad directly on the base channels or mounted on raised pads at support points. See Tables 1A and 1B for unit operating weights. See Figs. 1 and 2 for weight distribution based on recommended support points.

NOTE:If vibration isolators are required for a particular installation, use the data in Figs. 1 and 2 to make the proper selection.

Step 3 — Prepare Unit Mounting Support

Slab Mount —

Provide a level concrete slab that extends a minimum of 6 in. (150 mm) beyond unit cabinet. Install a gravel apron in front of condenser coil air inlet to prevent grass and foliage from obstructing airflow.

Step 4 — Rig and Mount the Unit

Rigging —

These units are designed for overhead rigging. Refer to the rigging label for preferred rigging method. Spreader bars are not required if top crating is left on the unit. All panels must be in place when rigging. As further protection for coil faces, plywood sheets may be placed against the sides of the unit, behind cables. Run cables to a central suspension point so

that the angle from the horizontal is not less than 45 degrees. Raise and set the unit down carefully.

If it is necessary to roll the unit into position, mount the unit on longitudinal rails, using a minimum of 3 rollers. Apply force to the rails, not the unit. If the unit is to be skidded into position, place it on a large pad and drag it by the pad. Do not apply any force to the unit.

Raise from above to lift the unit from the rails or pad when unit is in its final position.

After the unit is in position, remove all shipping materials and top crating.

Step 5 — Complete Refrigerant Piping Connections

Refrigerant lines must be carefully designed and constructed to ensure equipment reliability and efficiency. Line length, pressure drop, compressor oil return, and vertical separation are several of the design criteria that must be evaluated. See Table 1.

IMPORTANT:Do not bury refrigerant piping underground.

IMPORTANT:A refrigerant receiver is not provided with the unit. Do not install a receiver.

Table 1—CHS180-240 Piping Recommendations (Two-Circuit Unit)

R-410A Model Nominal Capacity	Equivalent Length					
	Length Equiv	0-38	38-75	75-113	113-150	150-188
	Length Lin	0-25	25-50	50-75	75-100	100-125
CHS180	Liquid Line	1/2	1/2	1/2	1/2	1/2
	Max Lift					
	Cool	25	50	75	100	125
	Heat	25	50	60	60	60
	Vapor Line	1 1/8	1 1/8	1 1/8	1 1/8	1 1/8
	Charge ea. (lbs)	20.9	22.8	24.8	26.6	28.6
CHS240	Liquid Line	1/2	1/2 5/8	1/2 5/8	5/8	5/8
	Max Lift					
	Cool	25	37 50	24 51	48	63
	Heat	25	50 50	60 60	60	60
	Vapor Line	1 1/8	1 1/8	1 1/8	1 1/8 1 3/8	1 3/8
	Charge ea. (lbs)	26.9	28.8 30.7	30.7 33.6	37.1	40.2
Legend:						
Length Equiv	Equivalent tubing length, including effects of refrigeration specialties devices					
Linear Lin	Typical linear tubing length, Feet (50% added to linear to define Equivalent Length for this table)					
Liquid Line	Tubing size, inches OD.					
Max Lift	Maximum liquid lift (indoor unit ABOVE outdoor unit only), at maximum permitted liquid line pressure drop — <ul style="list-style-type: none"> • Linear Length Less than 100 ft: Minimum 2.0°F subcooling entering TXV • Linear Length Greater than 100 ft: Minimum 0.5°F subcooling entering TXV 					
Vapor Line	Tube size, inches OD					
Charge	Charge Quantity, lbs. Calculated for both liquid line sizes (where applicable), but only with larger suction line size (where applicable)					
NOTE:	For applications with equivalent length greater than 188 ft (57 m) and/or linear length greater than 125 ft (38 m), contact your local Carrier representative.					

Check Vertical Separation —

If there is any vertical separation between the indoor and outdoor units, check to ensure that the separation is within allowable limits. Relocate equipment if necessary.

Provide Safety Relief —

If local codes dictate an additional safety relief device, purchase locally and install locally. Installation will require the recovery of the factory shipping charge before the factory tubing can be cut and the supplemental relief device is installed.

Refrigerant Line Sizing —

Consider the length of the piping required between the outdoor and indoor units. The maximum allowable line length is 100 ft (30.5 m). See Table 1. Refrigerant vapor piping should be insulated.

Install Filter Driers and Moisture Indicators —

Every unit MUST have bi-directional filter driers in the liquid lines. Locate the filter driers at the indoor unit, close to the evaporator coil's thermal expansion valve (TXV) inlets.

CHS units include two R-410A-duty filter driers, shipped in cartons attached to the unit basepan. Remove the filter driers and prepare to install in the liquid lines at the evaporator coil. Do not remove connection fitting plugs until ready to connect and braze the filter driers into the liquid line positions See Table 2.

IMPORTANT: A refrigerant receiver is not provided with the unit. Do not install a receiver.

Installation of liquid line moisture indicating sightglass in each circuit is recommended. Locate the sightglass(es) between the outlet of the filter drier and the TXV inlet.

Refer to Table 3 for recommendations on refrigeration specialties.

Select the filter drier for maximum unit capacity and minimum pressure drop. Complete the refrigerant piping from the indoor unit to the outdoor unit before opening the liquid and suction lines at the outdoor unit.

Table 2—R-410A-duty Filter Drier(s)

Model-Size	Qty	Liquid Line OD	Desiccant Volume	Part Number Ref
CHS180	2	1/2-in	16 cu. in.	KH43LS102
CHS240	2	1/2-in	16 cu. in.	KH43LS102

Table 3—Refrigerant Specialties Part Numbers

LIQUID LINE SIZE (in.)	LIQUID LINE SOLENOID VALVE (LLSV)	SOLENOID COIL	SIGHT GLASS	FILTER DRIER
1/2	1179872 plus 1183150 biflow kit	1179874	1179877	Provided with unit See Table 4
5/8	1179873 plus 1183150 biflow kit	1179874	1179878	

Install Liquid Line Solenoid Valves —

It is recommended that bi-directional solenoid valves be placed in the main liquids line for circuits 1 and 2 (see Fig. 4) between the outdoor unit and the indoor coil. Locate the solenoid valves at the end of the liquid lines, near the outdoor unit connections, with flow direction arrow pointed at the outdoor unit. Refer to Table 3. (A liquid line solenoid valve is required when the liquid line length exceeds 75 ft [23 m].) This valve prevents refrigerant migration (which causes oil dilution) to the compressor during the off cycle, at low outdoor ambient temperatures. Wire the solenoid according to the unit label diagram.

⚠ **CAUTION**

UNIT DAMAGE HAZARD
 Failure to follow this caution may result in equipment damage.
 Failure to use a solenoid valve relay (SUR) accessory may cause overload of Comfort Alert Diagnostic Module (CADM) and compressor alarm lock out.

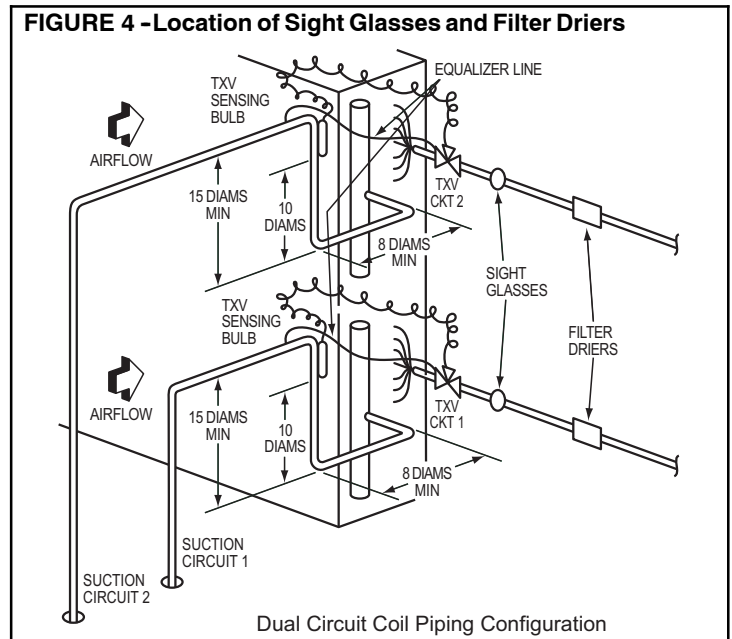

Capacity Control Liquid Line Solenoid Valve —

Evaporator capacity control via liquid solenoid valve is not recommended for use with CHS models.

Table 4—Minimum Outdoor Air Operating Temperature

UNIT	% Compress Capacity	MINIMUM OUTDOOR TEMP — F (C)*	
		Standard Unit	Head Pressure Control†
CHS180	100	35 (1.7)	-20 (-28.9)
CHS240		35 (1.7)	-20 (-28.9)

* Applies to Cooling mode of operation only.

† Wind baffles (field-supplied and field-installed) are recommended for all units with low ambient head pressure control. Refer to Low Ambient Control Installation Instructions (shipped with accessory) for details.

Make Piping Connections —

Piping connections at the CHS unit are ball valves with stub tube extensions. Do not open the unit service valves until all interconnecting tube brazing as been completed.

The stub tube connections include $\frac{1}{2}$ -in SAE service fittings with Schrader valve cores (see Fig. 5). Before making any brazed connections to the unit service valves, remove both Schrader valve caps and cores and save for re-installation. Connect a source for nitrogen to one of these service fittings during tube brazing to prevent the formation of copper oxides inside the tubes at brazed joints.

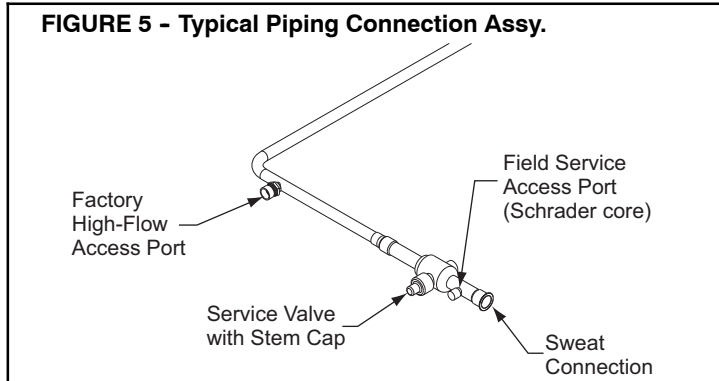

When connecting the field tubing to the CHS service valves, wrap the valves in wet rags to prevent overheating

Pressure-test all joints from outdoor unit connections over to the indoor coil, using nitrogen as pressure and with soap-and-bubbles.

When pressure-testing is completed, remove the nitrogen source at the outdoor unit service valves and re-install the two Schrader valve cores. Torque the cores to 2-3 in-lbs (23-34 N-cm).

Where vapor line is exposed to outdoor air, line must be insulated. See Table 5 for insulation requirements.

Table 5—Insulation for Vapor Line Exposed to Outdoor Conditions

LENGTH OF EXPOSED VAPOR LINE*		INSULATION THICKNESS†	
ft	m	in.	mm
10	3	$\frac{3}{8}$	10
25	8	$\frac{1}{2}$	13
35	11	$\frac{3}{4}$	19
50	15	$\frac{3}{4}$	19

* Recommended vapor line insulation for piping exposed to outdoor conditions to prevent loss of heating during heating cycle. When vapor line goes through interior spaces, insulation should be selected to prevent condensation on cooling cycle. Heating capacity should be reduced 1000 Btuh (295 W) if over 35 ft (11 m) of vapor line with $\frac{3}{4}$ in. (19 mm) insulation is exposed to outdoor conditions.

† Closed cell foam insulation with a thermal conductivity of: 0.28 Btu • in./ft² • h • °F (0.04 W/m • °C).

Evacuation/Dehydration —

Evacuate and dehydrate the connected refrigeration system(s) (excluding the CHS unit) to 500 microns using a two-stage vacuum pump attached to the service ports

outside the CHS service valves, following description in GTAC II, Module 4, System Dehydration.

⚠ WARNING

UNIT OPERATION AND SAFETY HAZARD

Failure to follow this warning could cause personal injury, death and/or equipment damage.

R-410A refrigerant systems operate at higher pressures than standard R-22 systems. Do not use R-22 service equipment or components on R-410A refrigerant equipment.

IMPORTANT: Charge in Cooling mode only!

Preliminary Charge —

Before starting the unit, charge R-410A liquid refrigerant into the high side of each CHS circuit through the liquid service valve(s). The amount of refrigerant added must be at least 80% of the operating charge listed in Table 1 for LINEAR line length LESS the factory charge quantity (if factory shipping charge has not been removed). See the following example.

Allow high and low side pressures to equalize. If pressures do not equalize readily, charge R-410A vapor (using special service manifold with expansion device) into the suction line service port for the low side of system to assure charge in the evaporator. Refer to GTAC II, Module 5, Charging, Recover, Recycling, and Reclamation for liquid charging procedures.

Example:

CHS240

60-ft (18.3 m) linear line length

Equivalent line length 90-ft (27.4 m)

Cooling Liquid Lift: 20-ft (6.1 m)

Select line sizes from Table 2 (CHS):

Liquid $\frac{1}{2}$ -in (provides liquid lift to 24-ft (7.3 m))

Vapor 1- $\frac{1}{8}$ in.

Charge (each circuit):

$\frac{1}{2}$ -in liquid line: 30.7 lbs (at 75-ft linear length)

80% of Operating Charge:

$0.80 \times 30.7 = 24.6$ lbs

Factory Shipping Charge: 9 lbs

Field-Charge (each circuit):

$24.6 - 9.0 = 15.6$ lbs

For linear line lengths longer than 125 ft (38.1 m), contact your local representative for system charge value.

Step 6 — Install Accessories

Accessories requiring modifications to unit wiring should be completed now. These accessories may include Winter Start controls, Low Ambient controls, phase monitor, Compressor LOOut. Refer to the instructions shipped with the accessory.

Step 7 — Complete Electrical Connections

⚠ WARNING

ELECTRICAL SHOCK HAZARD

Failure to follow this warning could result in personal injury or death.

Do not use gas piping as an electrical ground. Unit cabinet must have an uninterrupted, unbroken electrical ground to minimize the possibility of personal injury if an electrical fault should occur. This ground may consist of electrical wire connected to unit ground lug in control compartment, or conduit approved for electrical ground when installed in accordance with NEC (National Electrical Code); ANSI/NFPA 70, latest edition (in Canada, Canadian Electrical Code CSA [Canadian Standards Association] C22.1), and local electrical codes.

NOTE: Check all factory and field electrical connections for tightness. Field-supplied wiring shall conform with the limitations of 63°F (33°C) rise.

Field Power Supply —

If equipped with optional Powered Convenience Outlet: The power source leads to the convenience outlet's transformer primary are not factory connected. Installer must connect these leads according to required operation of the convenience outlet. If an always-energized convenience outlet operation is desired, connect the source leads to the line side of the unit-mounted disconnect. (Check with local codes to ensure this method is acceptable in your area.) If a de-energize via unit disconnect switch operation of the convenience outlet is desired, connect the source leads to the load side of the unit disconnect. On a unit without a unit-mounted disconnect, connect the source leads to compressor contactor C and indoor fan contactor IFC pressure lugs with unit field power leads.

All units except 208/230-v units are factory wired for the voltage shown on the nameplate. If the 208/230-v unit is to be connected to a 208-v power supply, the control transformer must be rewired by moving the black wire with the 1/4-in. female spade connector from the 230-v connection and moving it to the 208-v 1/4-in. male terminal on the primary side of the transformer. Refer to unit label diagram for additional information.

Field power wires are connected to the unit at line-side pressure lugs on compressor contactor C and TB1 (see wiring diagram label for control box component arrangement) or at factory-installed option non-fused disconnect switch. Max wire size is #4 AWG (copper only).

NOTE: TEST LEADS - Unit may be equipped with short leads (pigtailed) on the field line connection points on contactor C or optional disconnect switch. These leads are for factory run-test purposes only; remove and discard before connecting field power wires to unit connection points. Make field power connections directly to line connection pressure lugs only.

⚠ WARNING

FIRE HAZARD

Failure to follow this warning could result in intermittent operation or performance satisfaction.

Do not connect aluminum wire between disconnect switch and condensing unit. Use only copper wire. (See Fig. 6.)

FIGURE 6 - Disconnect Switch and Unit

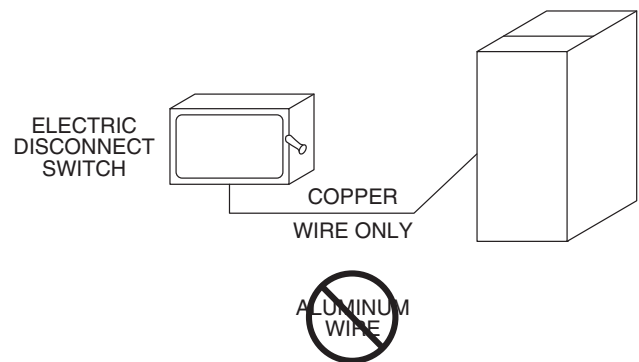

Units Without Factory-Installed Disconnect —

When installing units, provide a disconnect switch per NEC (National Electrical Code) of adequate size. Disconnect sizing data is provided on the unit informative plate. Locate on unit cabinet or within sight of the unit per national or local codes. Do not cover unit informative plate if mounting the disconnect on the unit cabinet.

Units with Factory-Installed Disconnect —

The factory-installed option disconnect switch is located in a weatherproof enclosure located under the main control box. The manual switch handle is accessible through an opening in the access panel.

All Units -

All field wiring must comply with NEC and all local codes. Size wire based on MCA (Minimum Circuit Amps) on the unit informative plate. See Fig. 7 for power wiring connections to the unit power terminal block and equipment ground. Maximum wire size is #4 ga AWG per pole.

Provide a ground-fault and short-circuit over-current protection device (fuse or breaker) per NEC Article 440 (or local codes). Refer to unit informative data plate for MOCP (Maximum Over-current Protection) device size.

FIGURE 7 - Power Wiring Connections

Units Without Disconnect Option

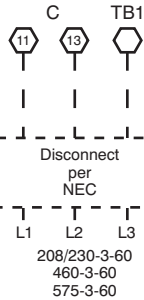

Units With Disconnect Option

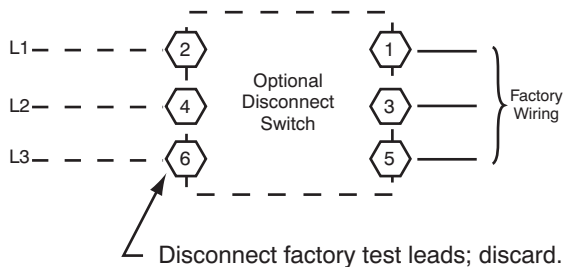

All field wiring must comply with the NEC and local requirements.

Voltage and Current Balance —

Voltage to compressor terminals during operation must be within voltage range indicated on unit nameplate. See Table 6. On 3-phase units, voltages between phases must be balanced within 2% and the current within 10%. Use the formula shown in the legend for Table 6, Note 5 to determine the percent of voltage imbalance. Operation on improper line voltage or excessive phase imbalance constitutes abuse and may cause damage to electrical components. Such operation would invalidate any applicable warranty.

Convenience Outlets

⚠ WARNING

ELECTRICAL OPERATION HAZARD

Failure to follow this warning could result in personal injury or death.

Units with convenience outlet circuits may use multiple disconnects. Check convenience outlet for power status before opening unit for service. Locate its disconnect switch, if appropriate, and open it. Tag-out this switch, if necessary.

Two types of convenience outlets are offered on CHS models: Non-powered and unit-powered. Both types provide a 125-volt GFCI (ground-fault circuit-interrupter) duplex receptacle rated at 15-A behind a hinged waterproof access cover, located on the end panel of the unit. See Fig. 10.

FIGURE 8 - Convenience Outlet Location

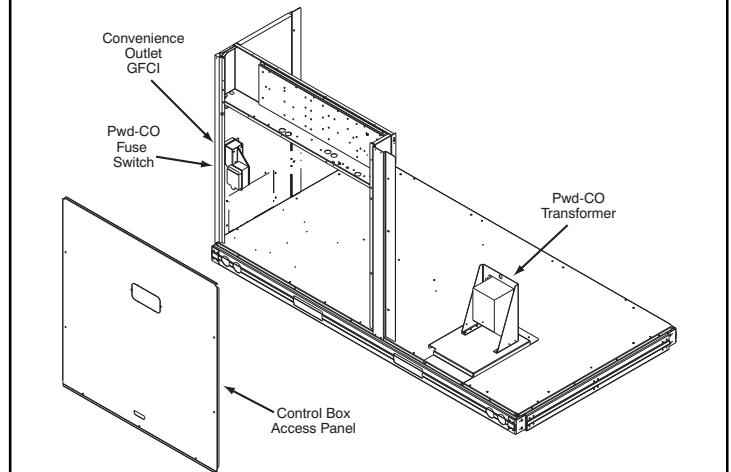

Non-powered type: This type requires the field installation of a general-purpose 125-volt 15-A circuit powered from a source elsewhere in the building. Observe national and local codes when selecting wire size, fuse or breaker requirements and disconnect switch size and location. Route 125-v power supply conductors into the bottom of the utility box containing the duplex receptacle.

Unit-powered type: A unit-mounted transformer is factory-installed to stepdown the main power supply voltage to the unit to 115-v at the duplex receptacle. This option also includes a manual switch with fuse, located in a utility box and mounted on a bracket behind the convenience outlet; access is through the unit's control box access panel. See Fig. 8.

The primary leads to the convenience outlet transformer are not factory-connected. Selection of primary power source is a customer-option. If local codes permit, the transformer primary leads can be connected at the line-side terminals on the unit-mounted non-fused disconnect or HACR breaker switch; this will provide service power to the unit when the unit disconnect switch or HACR switch is open. Other connection methods will result in the convenience outlet circuit being de-energized when the unit disconnect or HACR switch is open. See Fig. 9.

Duty Cycle: The unit-powered convenience outlet has a duty cycle limitation. The transformer is intended to provide power on an intermittent basis for service tools, lamps, etc; it is not intended to provide 15-amps loading for continuous duty loads (such as electric heaters for overnight use). Observe a 50% limit on circuit loading above 8-amps (i.e., limit loads exceeding 8-amps to 30 minutes of operation every hour).

Test the GFCI receptacle by pressing the TEST button on the face of the receptacle to trip and open the receptacle. Check for proper grounding wires and power line phasing if the GFCI receptacle does not trip as required. Press the RESET button to clear the tripped condition.

Fuse on power type: The factory fuse is a Bussman “Fusetron” T-15, non-renewable screw-in (Edison base) type plug fuse.

Using unit-mounted convenience outlets: Units with unit-mounted convenience outlet circuits will often require that two disconnects be opened to de-energize all power to the unit. Treat all units as electrically energized until the convenience outlet power is also checked and de-energization is confirmed. Observe National Electrical Code Article 210, Branch Circuits, for use of convenience outlets.

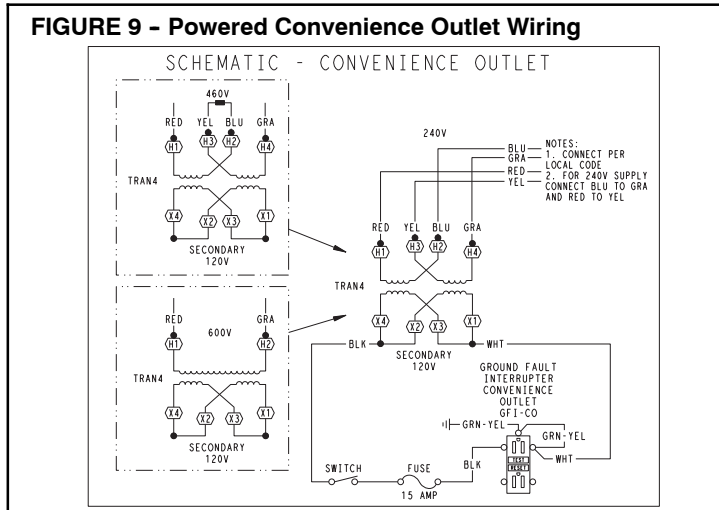

UNIT VOLTAGE	CONNECT AS	PRIMARY CONNECTIONS	TRANSFORMER TERMINALS
208, 230	240	L1: RED + YEL L2: BLU + GRA	H1 + H3 H2 + H4
460	480	L1: RED Splice BLU + YEL L2: GRA	H1 H2 + H3 H4
575	600	L1: RED L2: GRA	H1 H2

Installing Weatherproof Cover

A weatherproof while-in-use cover for the factory installed convenience outlets is now required by UL standards. This cover cannot be factory mounted due its depth; it must be installed at unit installation. For shipment, the convenience outlet is covered with a blank cover plate.

The weatherproof cover kit is shipped in the unit’s control box. The kit includes the hinged cover, a backing plate and gasket.

DISCONNECT ALL POWER TO UNIT AND CONVENIENCE OUTLET.

Remove the blank cover plate at the convenience outlet; discard the blank cover.

Loosen the two screws at the GFCI duplex outlet, until approximately 1/2in (13 mm) under screw heads are exposed. Press the gasket over the screw heads. Slip the backing plate over the screw heads at the keyhole slots and align with the gasket; tighten the two screws until snug (do not overtighten).

Mount the weatherproof cover to the backing plate as shown in Fig. 10. Remove two slot fillers in the bottom of the cover to permit service tool cords to exit the cover. Check for full closing and latching.

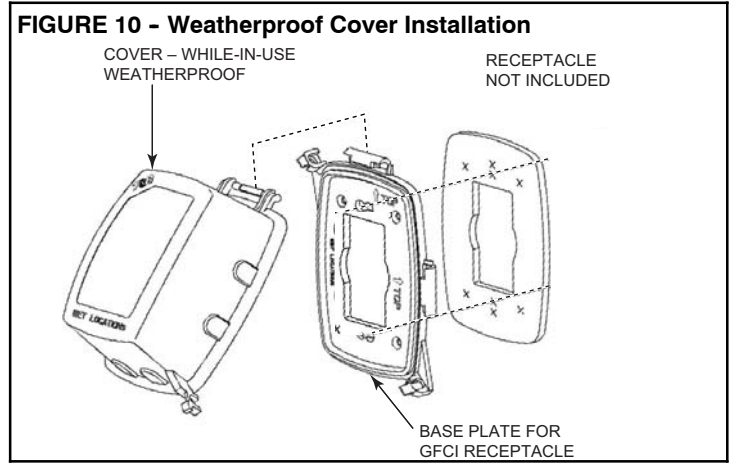

All Units —

Voltage to compressor terminals during operation must be within voltage range indicated on unit nameplate. See Table 7. On 3-phase units, voltages between phases must be balanced within 2% and the current within 10%. Use the formula shown in the legend for Table 7, Note 5 (see pages 14) to determine the percent of voltage imbalance. Operation on improper line voltage or excessive phase imbalance constitutes abuse and may cause damage to electrical components. Such operation would invalidate any applicable warranty.

Field Control Wiring —

CHS unit control voltage is 24 v. See Fig. 18 for typical field control connections and the unit’s label diagram for field-supplied wiring details. Route control wires to the CHS unit through the opening in unit’s end panel to the connections terminal board in the unit’s control box.

Remainder of the system controls connection will vary according to the specific construction details of the indoor section. Fig. 11 depicts typical connections to a FHS fan coil unit. Plan for field connections carefully and install control wiring correctly per the project plan. Additional components and supplemental transformer accessory may be required.

The CHS unit requires an external temperature control device. This device can be a thermostat (field-supplied) or a thermostat emulation device provided as part of a third-party Building Management System.

Thermostat —

Install an approved accessory thermostat according to installation instructions included with the accessory. For complete economizer function, select a two—stage cooling thermostat. Locate the thermostat accessory on a solid wall

in the conditioned space to sense average temperature in accordance with the thermostat installation instructions.

If the thermostat contains a logic circuit requiring 24-v power, use a thermostat cable or equivalent single leads of different colors with minimum of five leads. If the thermostat does not require a 24-v source (no "C" connection required), use a thermostat cable or equivalent with minimum of four leads. Check the thermostat installation instructions for additional features which might require additional conductors in the cable.

For wire runs up to 50 ft. (15 m), use no. 18 AWG (American Wire Gage) insulated wire (35°C minimum). For 50 to 75 ft. (15 to 23 m), use no. 16 AWG insulated wire (35°C minimum). For over 75 ft. (23 m), use no. 14 AWG insulated wire (35°C minimum). All wire sizes larger than no. 18 AWG cannot be directly connected to the thermostat and will require a junction box and splice at the thermostat.

FIGURE 11 - Typical Remote Thermostat Connections

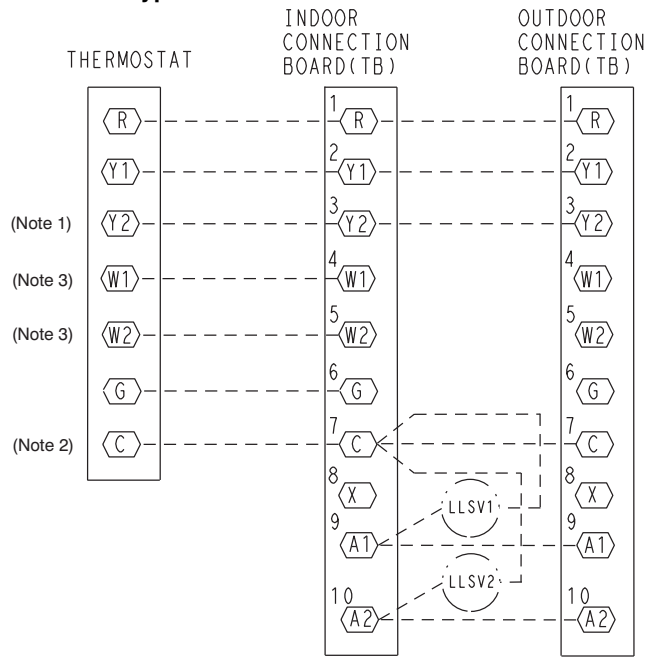

Note 1: Typical multi-function marking. Follow manufacturer's configuration instructions to select Y2.

Note 2: Connect only if thermostat requires 24-vac power source.

Note 3: Connect W1 and W2 if supplemental heaters are installed

--- Field Wiring

Table 6—Electrical Data — CHS180-240 60 Hz Units

UNIT SIZE CHS	NOMINAL POWER SUPPLY	VOLTAGE RANGE		COMPRESSOR				NO C.O. or UNPWRD C.O.					
				No. 1		No. 2		OFM		POWER SUPPLY		DISCONNECT SIZE	
	V-Ph-Hz	Min	Max	RLA	LRA	RLA	LRA	Qty	FLA (ea)	MCA	FUSE or HACR BRKR	FLA	LRA
180	208/230-3-60	187	253	25.0	164	25.0	164	3	1.5	60.8/60.8	80/80	63/63	337/337
	460-3-60	414	506	12.2	100	12.2	100	3	0.8	29.9	40	31	206
	575-3-60	518	633	9.7	78	9.7	78	3	0.7	23.9	30	2	162
240	208/230-3-60	187	253	30.1	225	30.1	225	4	1.5	73.7/73.7	100/100	76/76	462/462
	460-3-60	414	506	16.7	114	16.7	114	4	0.8	40.8	50	42	236
	575-3-60	518	633	12.2	80	12.2	80	4	0.7	30.3	40	31	168

UNIT SIZE CHS	NOMINAL POWER SUPPLY	VOLTAGE RANGE		COMPRESSOR				w/ PWRD C.O.					
				No. 1		No. 2		OFM		POWER SUPPLY		DISCONNECT SIZE	
	V-Ph-Hz	Min	Max	RLA	LRA	RLA	LRA	Qty	FLA (ea)	MCA	FUSE or HACR BRKR	FLA	LRA
180	208/230-3-60	187	253	25.0	164	25.0	164	3	1.5	65.6/65.6	90/90	68/68	342/342
	460-3-60	414	506	12.2	100	12.2	100	3	0.8	32.1	40	33	208
	575-3-60	518	633	9.7	78	9.7	78	3	0.7	25.6	30	27	164
240	208/230-3-60	187	253	30.1	225	30.1	225	4	1.5	78.5/78.5	100/100	82/82	467/467
	460-3-60	414	506	16.7	114	16.7	114	4	0.8	43	50	45	238
	575-3-60	518	633	12.2	80	12.2	80	4	0.7	32	40	33	170

Legend and Notes for Table 6

LEGEND:

- BRKR - Circuit breaker
- CO - Convenient outlet
- FLA - Full Load Amps
- LRA - Locked Rotor Amps
- MCA - Minimum Circuit Amps Protection
- NEC - National Electrical Code
- PWRD CO - Powered convenient outlet
- RLA - Rated Load Amps
- UNPWR CO - Unpowered convenient outlet



NOTES:

1. In compliance with NEC requirements for multimotor and combination load equipment (refer to NEC Articles 430 and 440), the overcurrent protective device for the unit shall be fuse or HACR breaker. Canadian units may be fuse or circuit breaker.
2. The MCA values are calculated in accordance with The NEC. Article 440.
3. Motor RLA and LRA values are established in accordance with Underwriters' Laboratories (UL). Standard 1995.
4. The 575-v units are UL, Canada-listed only.
5. **Unbalanced 3-Phase Supply Voltage**
Never operate a motor where a phase imbalance in supply voltage is greater than 2%. Use the following formula to determine the percentage of voltage imbalance.

Example: Supply voltage is 230-3-60

$$\% \text{ Voltage Imbalance} = 100 \times \frac{\text{max voltage deviation from average voltage}}{\text{average voltage}}$$



AB = 224 v
BC = 231 v
AC = 226 v

$$\text{Average Voltage} = \frac{(224 + 231 + 226)}{3} = \frac{681}{3} = 227$$

Determine maximum deviation from average voltage.

- (AB) 227 - 224 = 3 v
- (BC) 231 - 227 = 4 v
- (AC) 227 - 226 = 1 v

Maximum deviation is 4 v.

Determine percent of voltage imbalance.

$$\% \text{ Voltage Imbalance} = 100 \times \frac{4}{227} = 1.76\%$$

This amount of phase imbalance is satisfactory as it is below the maximum allowable 2%.

IMPORTANT: If the supply voltage phase imbalance is more than 2%, contact your local electric utility company immediately.

PRE-START-UP

IMPORTANT: Before beginning Pre-Start-Up or Start-Up, review Start-Up Checklist at the back of this book. The Checklist assures proper start-up of a unit and provides a record of unit condition, application requirements, system information, and operation at initial start-up.

⚠ CAUTION

UNIT DAMAGE HAZARD

Failure to follow this caution may result in equipment damage.

Do not attempt to start the heat pump system, even momentarily, until the following steps have been completed. Compressor damage may result.

System Check

1. Check all indoor section and other equipment auxiliary components. Consult the manufacturer's instructions regarding any other equipment connected to the condensing unit. If the unit has field-installed accessories, be sure all are properly installed and correctly wired. If used, the airflow switch must be properly installed.
2. Be sure the unit is properly leak checked and dehydrated.
3. Check tightness of all electrical connections.
4. Open the liquid line and suction line service valves.
5. Be sure the unit is properly charged. See "Preliminary Charge", below.
6. The electrical power source must agree with the unit's nameplate rating.
7. The crankcase heater must be firmly attached to the compressor crankcase. Be sure the crankcase is warm (heater must be on for 24 hours before starting compressor).

Turn On Crankcase Heater

Turn on the crankcase heater for 24 hours before starting the unit to be sure all the refrigerant is out of the oil. To energize the crankcase heater, proceed as follows:

1. Set the space thermostat set point above the space temperature so there is no demand for cooling.
2. Close the field disconnect.

Preliminary Charge

Before starting the unit, charge liquid refrigerant into the high side of the system through the liquid service valve. The amount of refrigerant added must be at least 80% of the operating charge listed in the Physical Data table (Tables 1A and 1B). Allow high and low side pressures to equalize before starting compressor. If pressures do not equalize readily, charge vapor on low side of system to assure charge in the evaporator. Refer to GTAC II, Module 5, Charging, Recover, Recycling, and Reclamation for liquid charging procedures.

⚠ CAUTION

UNIT DAMAGE HAZARD

Failure to follow this caution may result in equipment damage.

Prior to starting compressor, a preliminary charge of refrigerant must be added to avoid possible compressor damage.

START-UP

CHS Units

The compressor crankcase heater must be on for 24 hours before start-up. After the heater has been on for 24 hours, the unit can be started. If no time elapsed since the preliminary charge step was completed, it is unnecessary to wait the 24-hour period.

Preliminary Checks —

1. Check that electric power supply agrees with unit nameplate data.
2. Verify that the compressor crankcase heater is securely in place.
3. Check that the compressor crankcase heater has been on at least 24 hours.
4. Recheck for leaks using the procedure outlined in the Pre-Start-Up section, Leak Test and Dehydration. If any leaks are detected, repair as required. Evacuate and dehydrate as described in the Leak Test and Dehydration section.
5. Ensure that the preliminary charge has been added as described in the Pre-Start-Up section, Preliminary Charge.
6. All internal wiring connections must be tight, and all barriers and covers must be in place.

NOTE: The units are factory charged with the required amount of oil. If recharging is required, use Emkarate RL 32-3MAF.

Compressor Rotation —

On 3-phase units with scroll compressors, it is important to be certain that the compressor is rotating in the proper direction. CHS units are equipped with a Comfort Alert Diagnostic Module (CADM). Alert Code 7 indicates reverse power phasing.

To correct phase order:

1. Turn off power to the unit, tag disconnect.
2. Reverse any two of the unit power leads.
3. Reapply power to the compressor, verify correct pressures.

To verify the compressor is rotating in the proper direction:

1. Connect service gages to the suction and liquid pressure fittings.
2. Energize the compressor.
3. The suction pressure should drop and the liquid pressure should rise, as is normal on any start-up.

Compressor Overload —

This overload interrupts power to the compressor when either the current or internal motor winding temperature becomes excessive, and automatically resets when the internal temperature drops to a safe level. This overload may require up to 60 minutes (or longer) to reset. If the internal overload is suspected of being open, disconnect the electrical power to the unit and check the circuit through the overload with an ohmmeter or continuity tester.

Advanced Scroll Temperature Protection (ASTP) —

A label located above the terminal box identifies Copeland Scroll compressor models that contain this technology. See Fig. 12. Advanced Scroll Temperature Protection (ASTP) is a form of internal discharge temperature protection, that unloads the scroll compressor when the internal temperature reaches approximately 300°F. At this temperature, an internal bi-metal disk valve opens and causes the scroll elements to separate, which stops compression. Suction and discharge pressures balance while the motor continues to run. The longer the compressor runs unloaded, the longer it must cool before the bi-metal disk resets. See Fig. 13.

FIGURE 12 - Advanced Scroll Temperature Protection Label



FIGURE 13 - Recommended Cool-Down Time After Compressor is Stopped

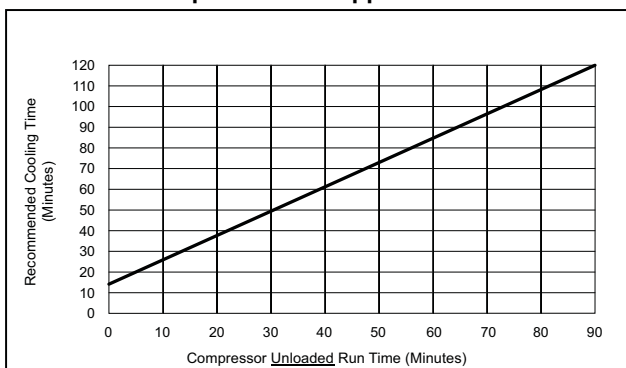

*Times are approximate.

NOTE: Various factors, including high humidity, high ambient temperature, and the presence of a sound blanket will increase cool-down times.

To manually reset ASTP, the compressor should be stopped and allowed to cool. If the compressor is not stopped, the motor will run until the motor protector trips, which occurs up to 90 minutes later. Advanced Scroll Temperature Protection will reset automatically before the motor protector resets, which may take up to 2 hours.

Start Unit —

Set the space thermostat to a set point above space temperature so that there is no demand for cooling. Close the CHS disconnect switch. Only the crankcase heater will be energized.

Reset the space thermostat below ambient so that a call for cooling is ensured.

⚠ CAUTION

UNIT DAMAGE HAZARD

Failure to follow this caution may result in equipment damage.

Never charger liquid into the low-pressure side of the system. Do not overcharge. During charging or removal of refrigerant, be sure indoor-fan system is operating. Ensure both outdoor fan motors re running; bypass any Motormaster function.

Adjust Refrigerant Charge —

The unit must be charged in Cooling mode only. Refer to Cooling Charging Charts, Figs. 14 and 15. For applications with line lengths greater than 100 ft, contact a representative. Vary refrigerant until the conditions of the chart are met. The charts are based on charging the units to the correct subcooling for the various operating conditions. Accurate pressure gage and temperature sensing device are required. Connect the pressure gage to the service port on the liquid line service valve. Mount the temperature sensing device on the liquid line close to the liquid line service valve, and insulate it so that outdoor ambient temperature does not affect the reading. Indoor airflow must be within the unit's normal operating range. Operate the unit for a minimum of 15 minutes. Ensure that pressure and temperature readings have stabilized. Plot the liquid pressure and temperature on chart and add or reduce the charge to meet the curve. Adjust the charge to conform with the charging chart, using the liquid pressure and temperature to read the chart.

Final Checks —

Ensure that all safety controls are operating, control panel covers are on, and the service panels are in place.

FIGURE 14 - CHS180 Charging Chart

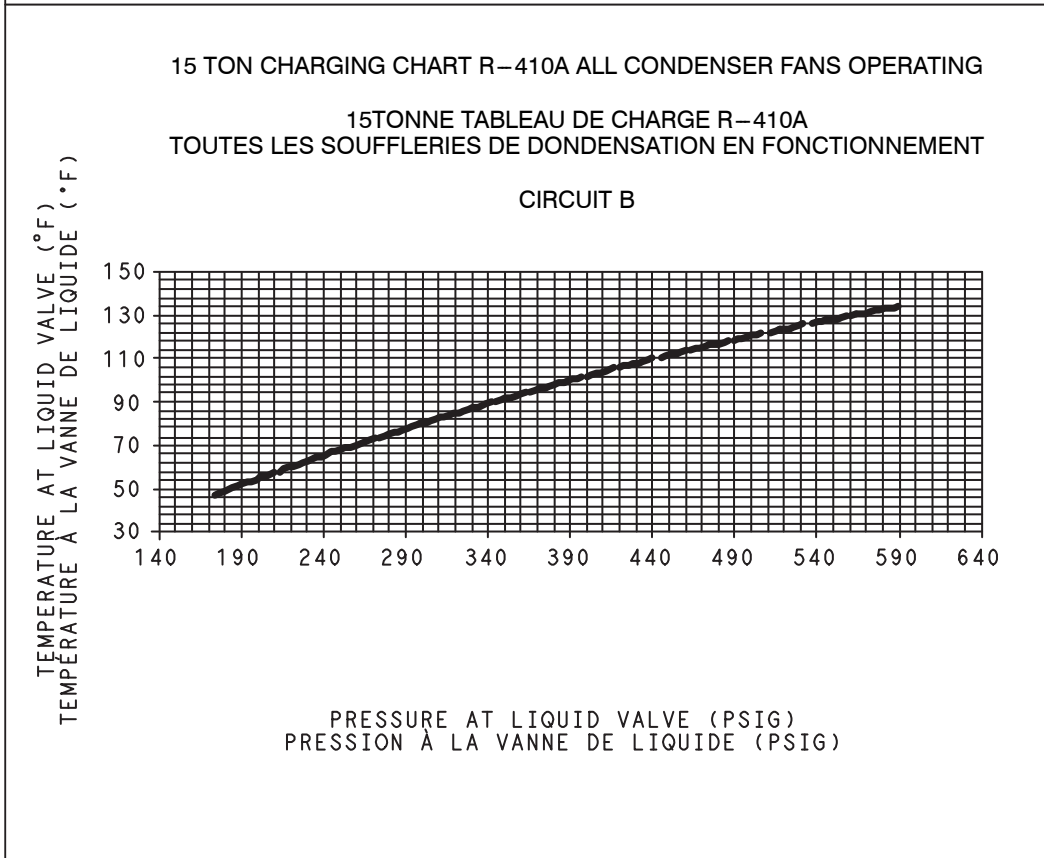
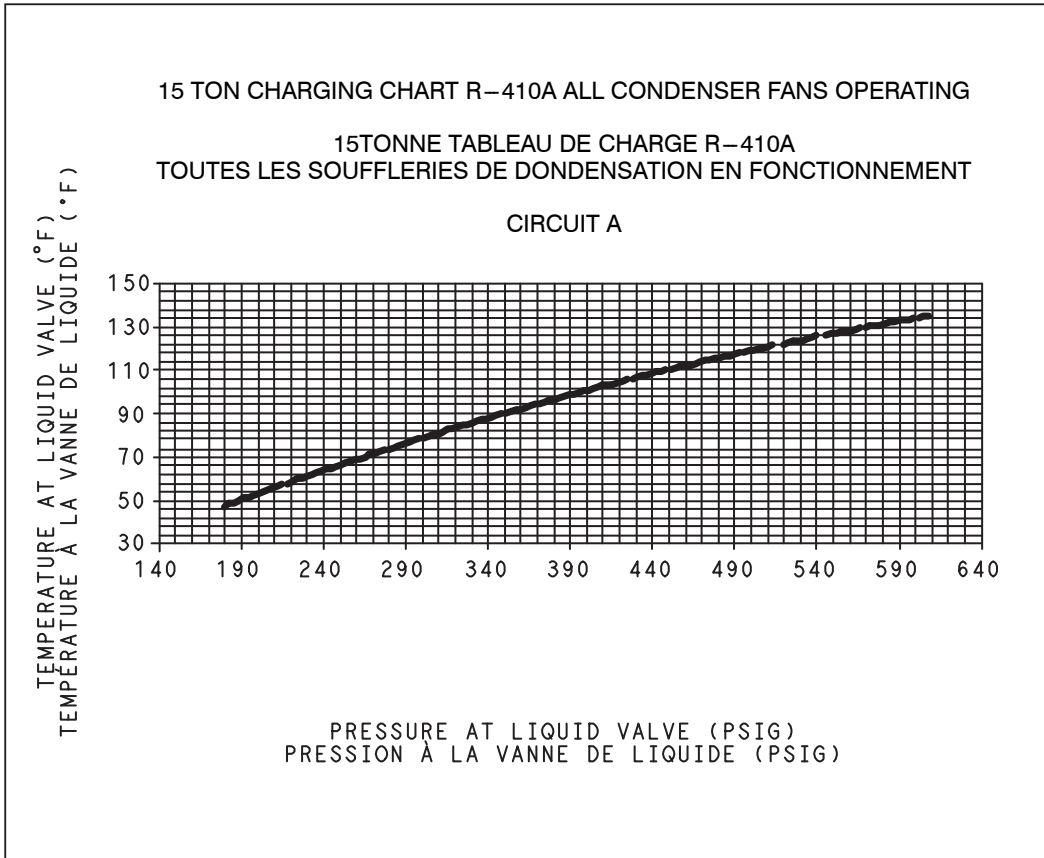

FIGURE 15 - CHS240 Charging Chart

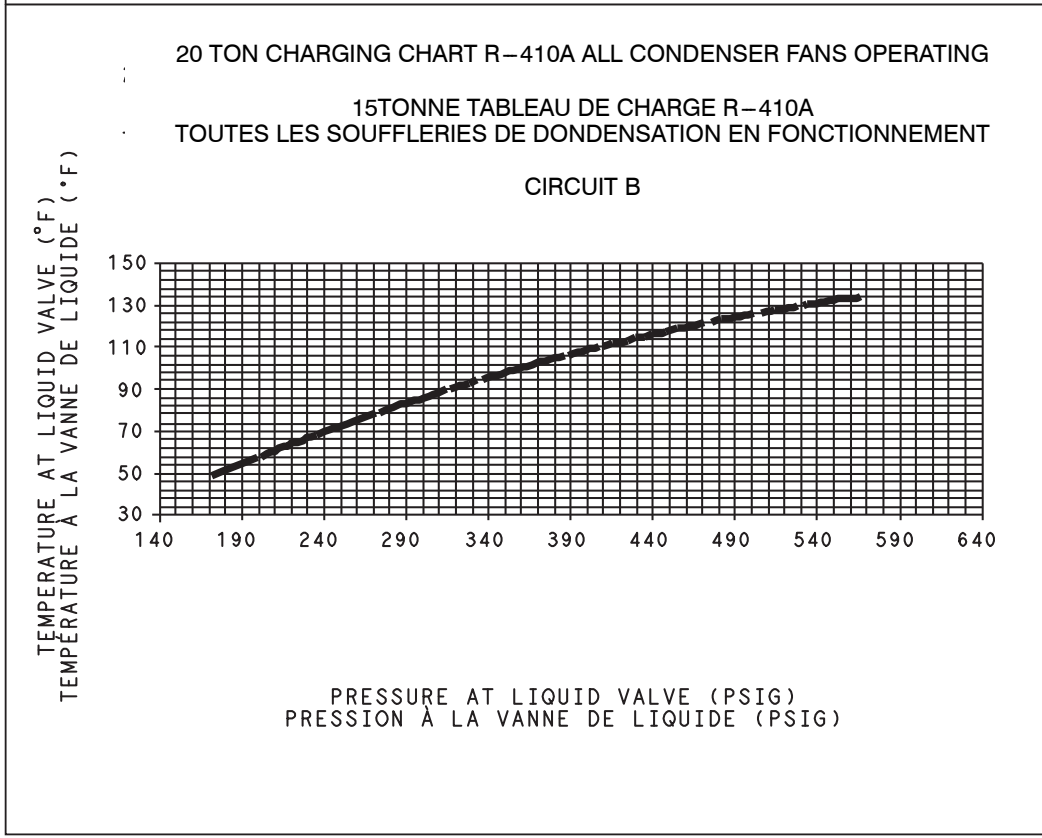
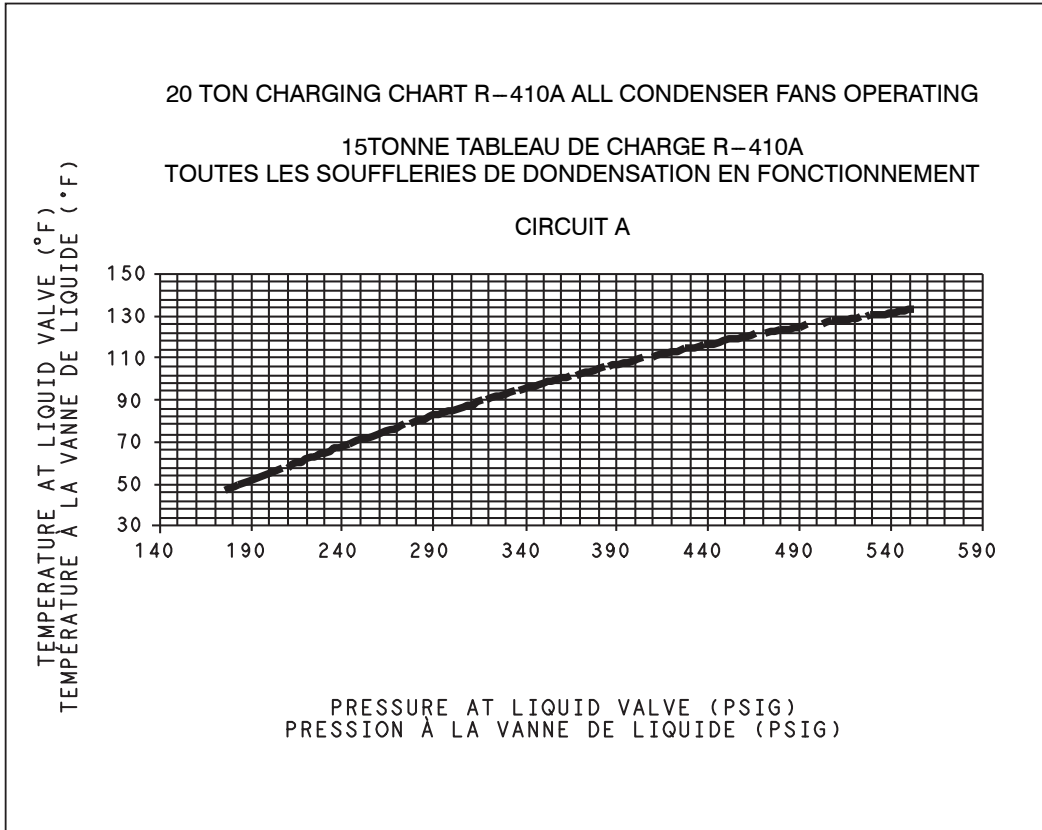
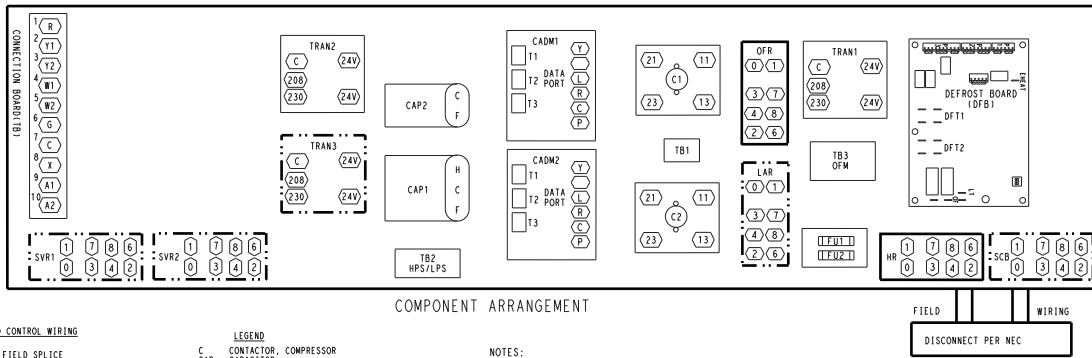

FIGURE 16 - CHS180 Power Schematic (208/230-3-60 shown)



FIELD CONTROL WIRING

- △ FIELD SPLICE
- (T) MARKED WIRE
- TERMINAL (UNMARKED)
- TERMINAL (UNMARKED)
- TERMINAL BLOCK
- SPLICE
- FACTORY WIRING
- - - FIELD CONTROL WIRING
- FIELD POWER WIRING
- ACCESSORY OR OPTIONAL WIRING
- TO INDICATE COMMON POTENTIAL ONLY, NOT TO REPRESENT WIRING

LEGEND

- C CONTACTOR, COMPRESSOR CAPACITOR
- CH CRANKCASE HEATER
- CADM COMFORT ALERT - DIAGNOSTICS MODULE
- COMP COMPRESSOR MOTOR
- DFB DEFROST BOARD
- DFT DEFROST THERMOSTAT
- EDTIP EQUIPMENT
- FPT FREEZE PROTECTION THERMOSTAT
- FU FUSE
- GR GROUND
- HPS HIGH PRESSURE SWITCH
- HR HEATER RELAY
- LAR LOW AMBIENT RELAY
- LAS LOW AMBIENT SWITCH
- LLSW LIQUID LINE SOLENOID VALVE
- LOC LOSS OF CHARGE SWITCH
- OFM OUTDOOR FAN MOTOR
- OFR OUTDOOR FAN RELAY
- QT QUADRUPLE TERMINAL
- SCB SPEED CONTROL BYPASS
- SVR SOLENOID VALVE RELAY
- TB TERMINAL BLOCK
- TRAN TRANSFORMER

NOTES:

1. IF ANY OF THE ORIGINAL WIRE FURNISHED MUST BE REPLACED, IT MUST BE REPLACED WITH TYPE 90 C WIRE OR ITS EQUIVALENT.
2. USE COPPER CONDUCTORS ONLY.
3. COMPRESSORS AND FAN MOTORS ARE THERMALLY PROTECTED. THREE PHASE MOTORS ARE PROTECTED AGAINST PRIMARY SINGLE PHASING CONDITIONS.
4. TRANSFORMER IS WIRED FOR 230V UNIT. IF UNIT IS TO BE RUN WITH 208V POWER SUPPLY, DISCONNECT BLK WIRE FROM 230V TAP AND CONNECT TO 208V TAP.
5. ON UNITS WITH SPEED CONTROL, REMOVE BLK WIRE FROM OFM1 & 3 AT TB3 AND RECONNECT TO SCB TERMINAL 2 HARNESS.

SCHEMATIC
208/230V 15T DUAL HP

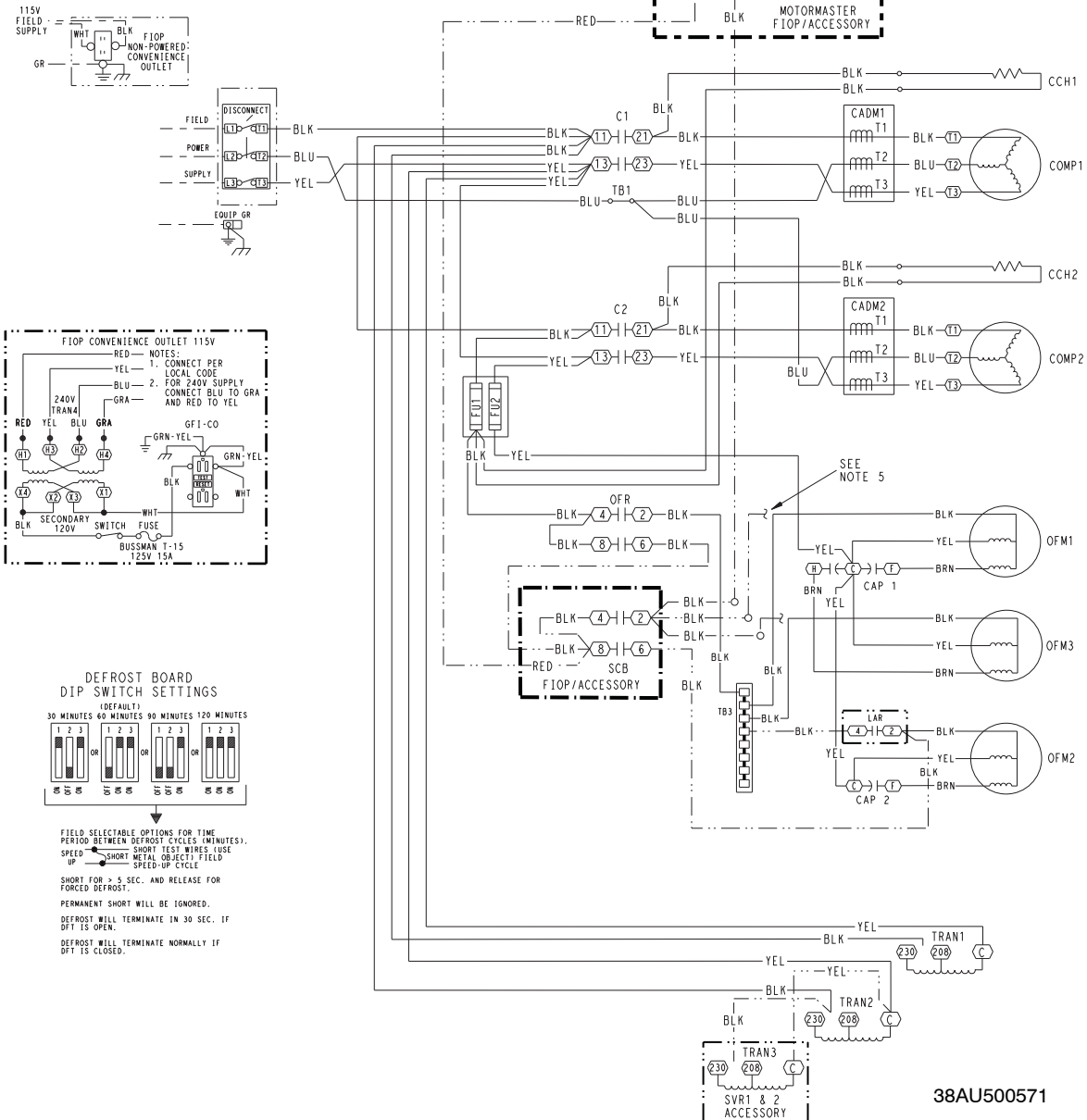

38AU500571

FIGURE 18 - CHS180 Power Schematic (460-3-60 shown)

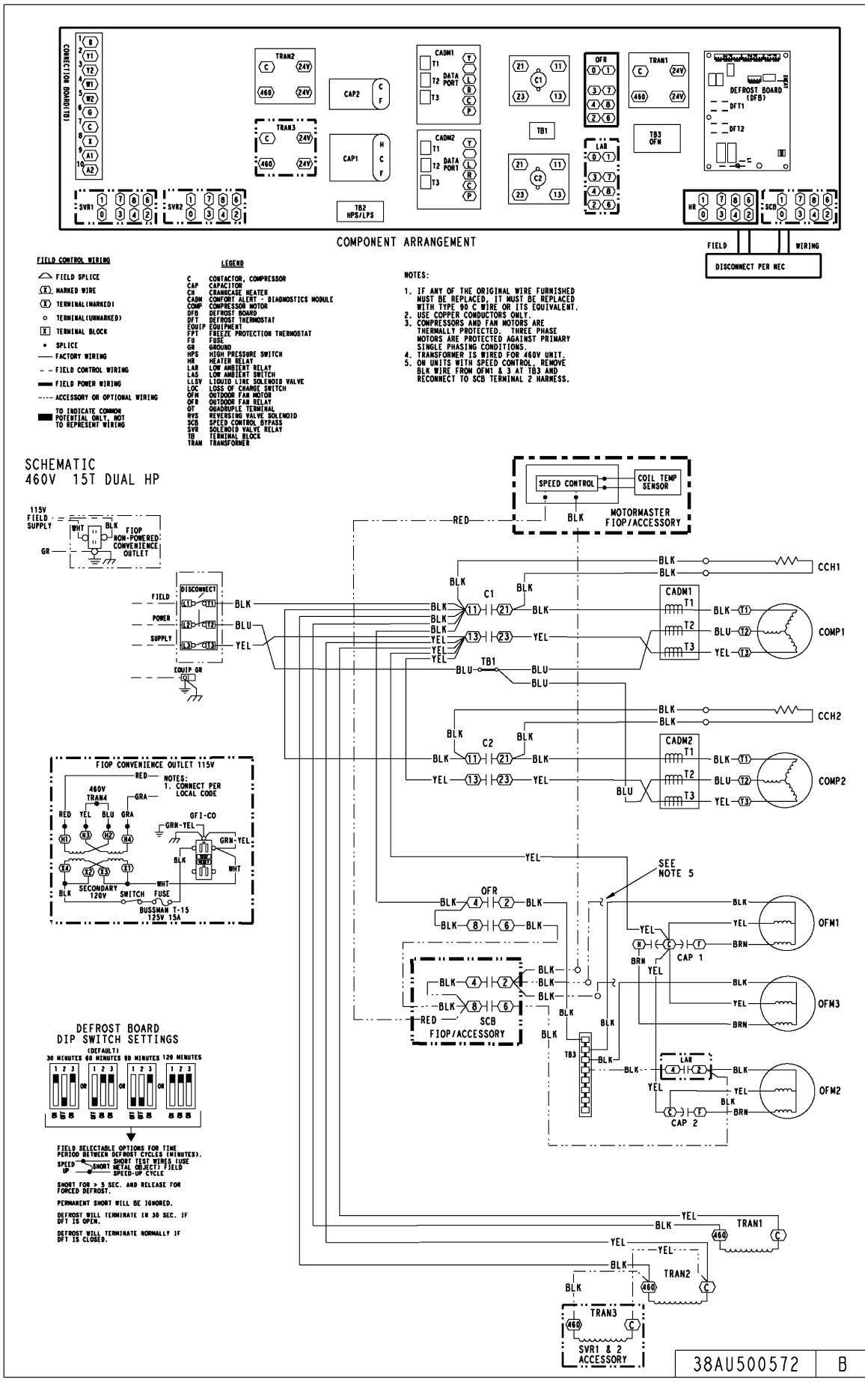

FIGURE 19 - CHS240 Power Schematic (460-3-60 shown)

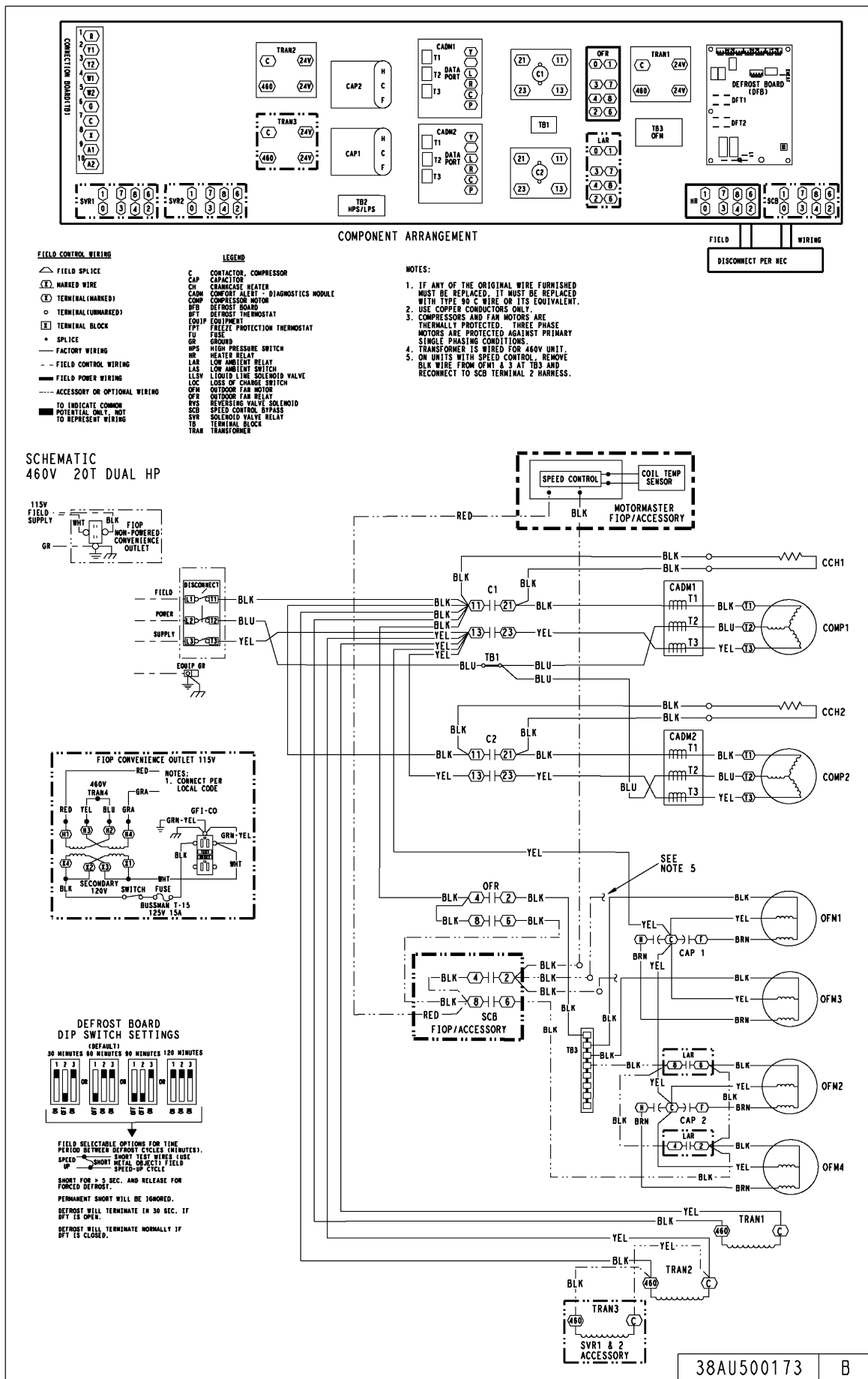

FIGURE 20 - CHS180 Power Schematic (575-3-60 shown)

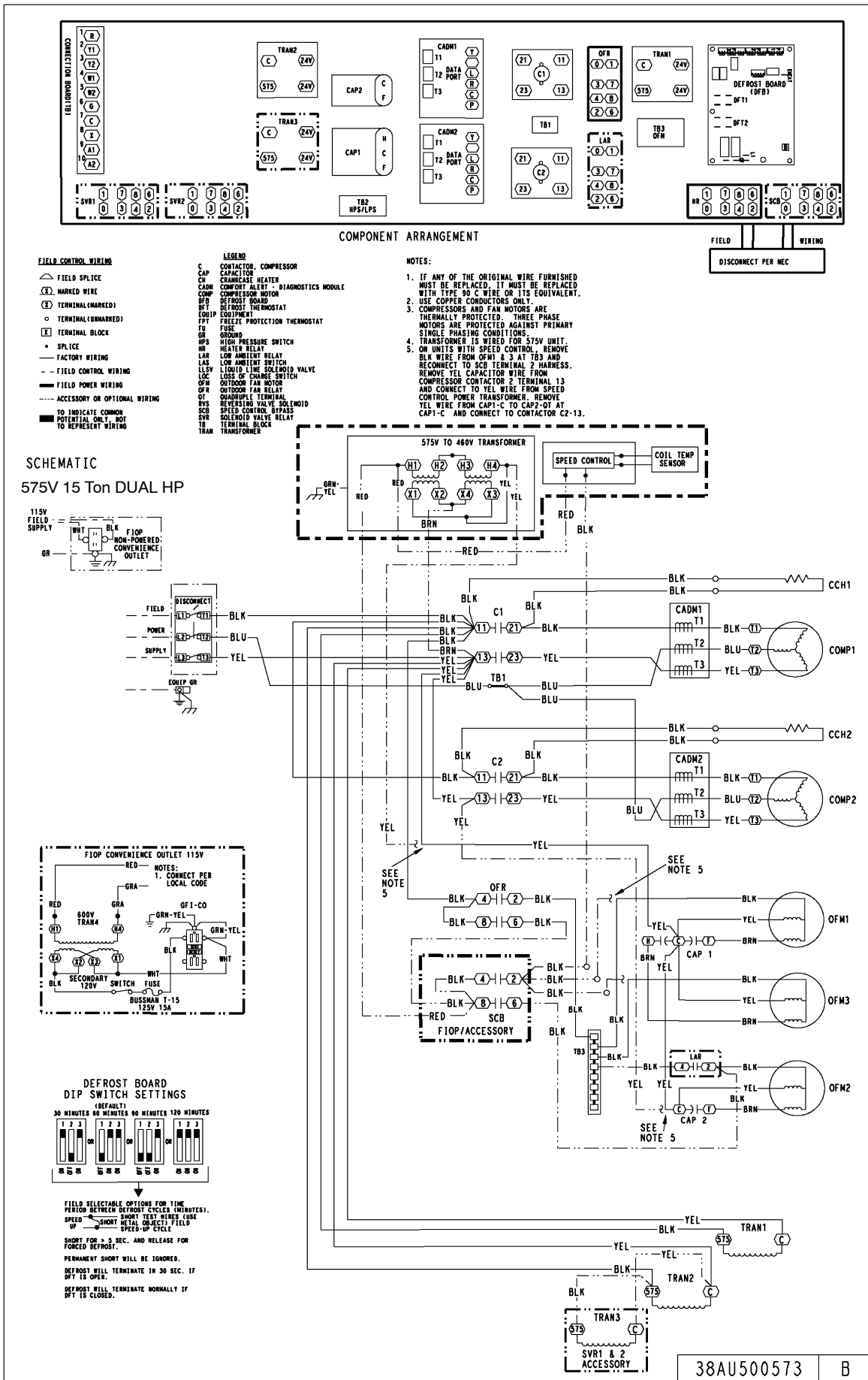

FIGURE 21 - CHS240 Power Schematic (575-3-60 shown)

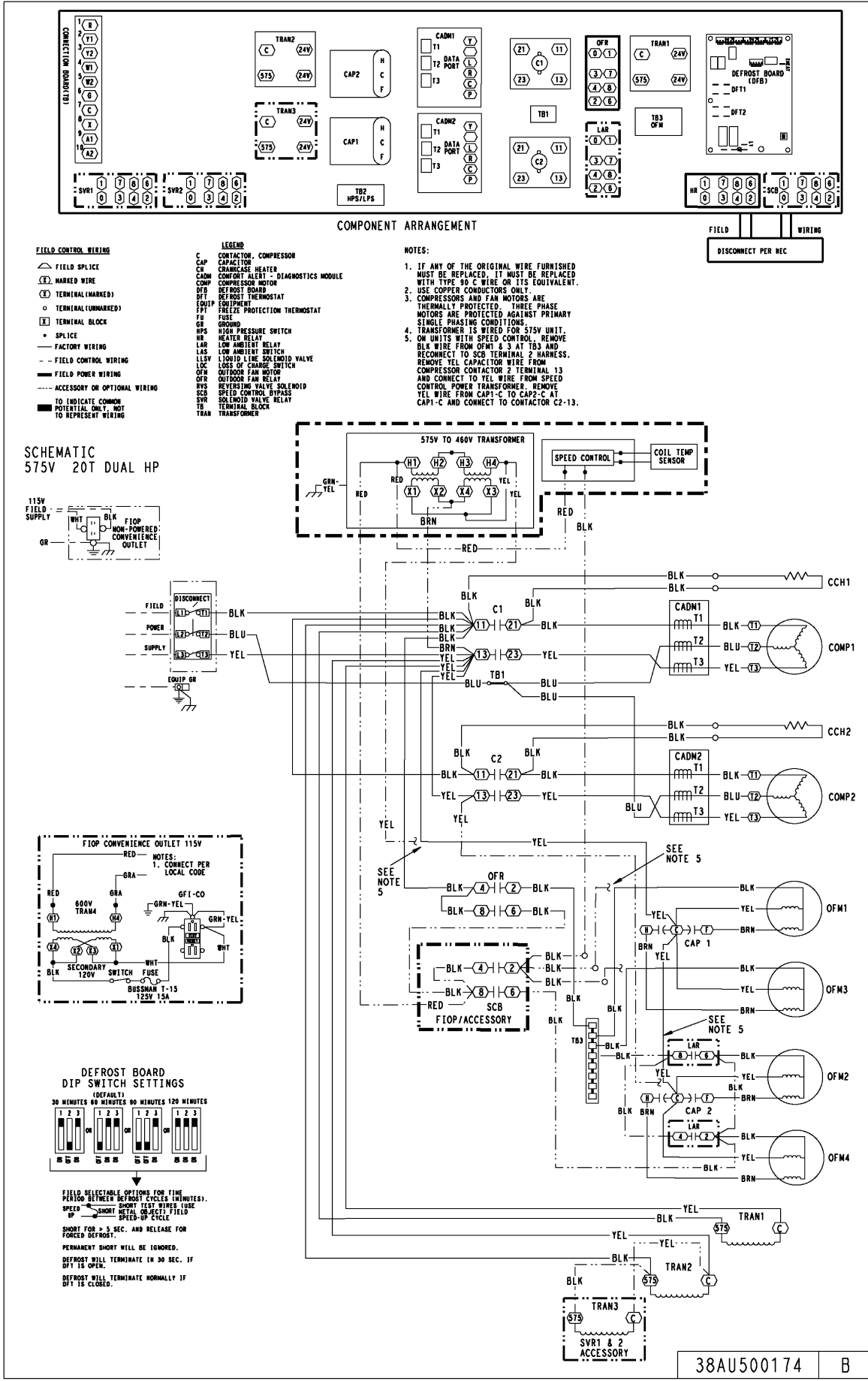
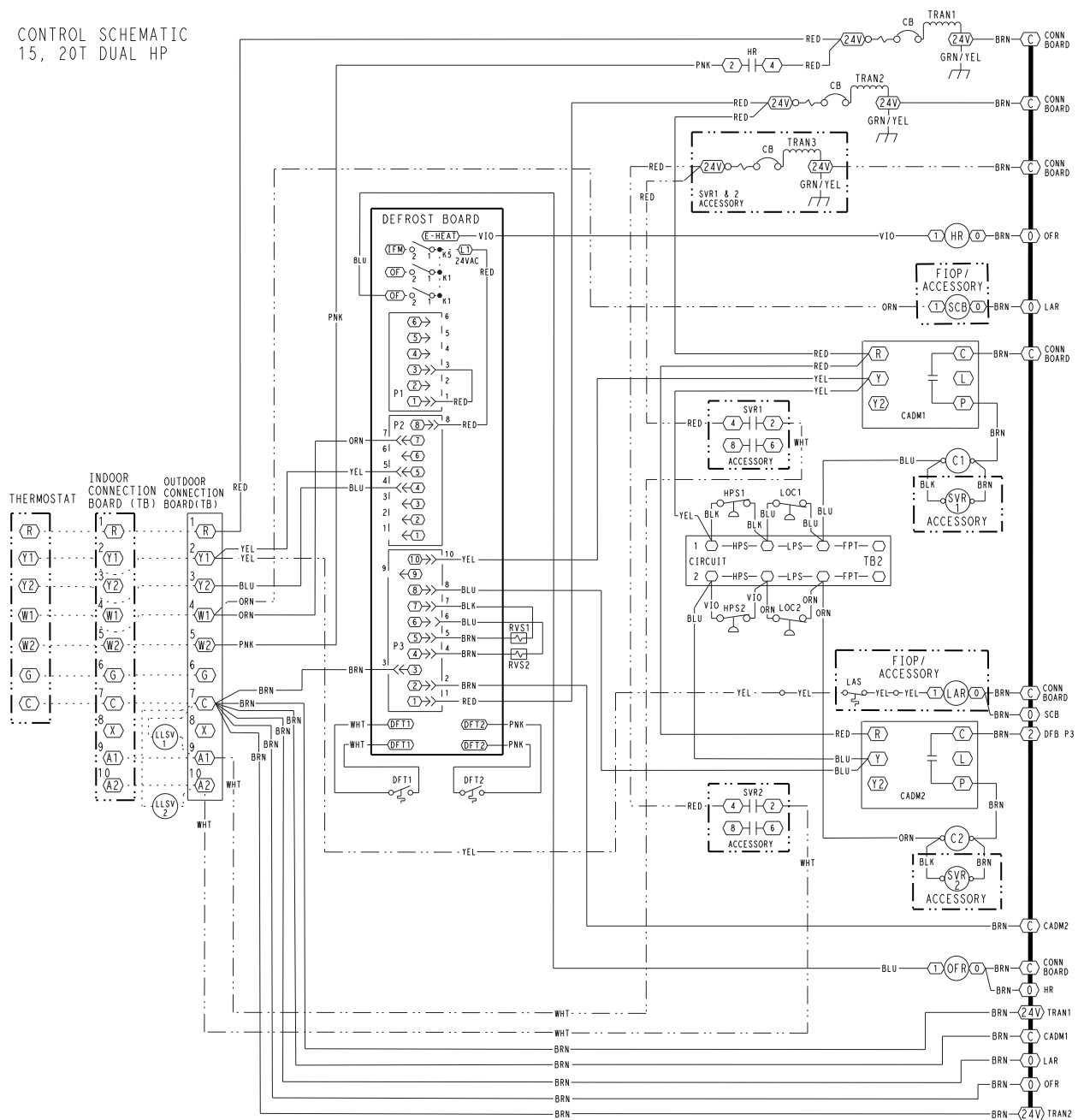

FIGURE 22 - CHS180/240 Control Schematic

CONTROL SCHEMATIC
15, 20T DUAL HP



OPERATING SEQUENCE

Base Unit Controls

Indoor (Supply) Fan —

The indoor fan contactor (IFC) is remotely located at the fan coil or fan section. If the thermostat fan operation is selected as Continuous, the IFC is energized and the indoor (supply) fan motor runs continuously. If the thermostat fan operation is selected as Automatic, the IFC will be energized on a call for Cooling or Heating; indoor (supply) fan motor runs. When thermostat is satisfied, the IFC is de-energized and indoor (supply) fan motor stops.

Cooling, Unit Without Economizer —

When thermostat calls for Cooling, terminal Y1 is energized. The CHS's Defrost Board (DFB) receives this input at P2-5. DFB issues 24-v outputs at OF, P3-7 (RVS1) and P3-10 (COMP1). The OF output energizes outdoor fan relay (OFR); both outdoor fan motors start and run. The output RVS1 energizes the reversing valve solenoid (RVS); Reversing valve switches to Cooling position.

Output PL3-10 (COMP1, 24-v) is received at CADM terminal Y. If anti-recycle time delay period has not expired, safety pressure switches are open, and/or lockout alarms are active, CADM relay will remain open, preventing compressor start. When safety pressure switches are closed and CADM time delay expires, the CADM relay closes, energizing Solenoid Valve Relay SVR and compressor contactor C. SVR contacts close, energizing the external liquid line solenoid valve. Solenoid valve LLSV opens. Compressor contactor C closes, energizing the compressor motor. Compressor starts and system runs in Cooling mode.

When space cooling load is satisfied, terminal Y1 is de-energized. Compressor and outdoor fan motors stop. Liquid line solenoid valve LLSV is de-energized and valve closes. CADM begins its three-minute anti-recycle time delay.

If either the Loss of Charge (LOC) Switch or High Pressure Switch (HPS) opens while Y1 remains energized, the compressor contactor C and relay SVR are de-energized; compressor stops and liquid line solenoid is de-energized (valve closes). CADM initiates a TRIP event (cooling demand sensed at CADM terminal Y but no current is measured at T1, T2, T3 motor sensors); CADM relay opens and RED LED is illuminated. TRIP condition maintains lockout of compressor operation until CADM is manually reset. Reset CADM by cycling unit main power.

Reversing valve solenoid (RVS) is energized in Cooling modes. This solenoid will remain energized until the next Heating mode is initiated.

Cooling, Unit With Economizer —

Refer to fan coil unit installation instructions and economizer accessory installation instructions for operating sequences when system is equipped with accessory economizer.

Heating —

When the thermostat calls for first stage heating, terminal W1 is energized. The CHS's Defrost Board (DFB) receives this input at P2-7. The DFB removes the output at P3-7

(RVS1); the reversing valve solenoid is de-energized and the reversing valve moves to Heating position.

DFB issues outputs at OF and P3-10 (COMP1). Outdoor fan relay OFR is energized; both outdoor fan motors run.

Output PL3-10 (COMP1, 24-v) is received at CADM terminal Y. If anti-recycle time delay period has not expired and/or safety pressure switches are open, outdoor lockout alarms are active, CADM relay will remain open, preventing compressor start. When safety pressure switches are closed and CADM time delay expires, the CADM relay closes, energizing Solenoid Valve Relay SVR and compressor contactor C. SVR contacts close, energizing the external liquid line solenoid valve. Solenoid valve LLSV opens. Compressor contactor C closes, energizing the compressor motor. Compressor starts and system runs in Heating mode, providing Stage 1 Heat.

When the space heating load is satisfied terminal W1 is de-energized. Compressor and outdoor fan operations stop. Liquid line solenoid LLSV is de-energized and valve closes. CADM begins its three-minute anti-recycle time delay.

If either the Loss of Charge (LOC) Switch or High Pressure Switch (HPS) opens while, the compressor contactor C and relay SVR are de-energized; compressor stops and liquid line solenoid is de-energized (valve closes). CADM initiates a TRIP event (compressor demand sensed at CADM terminal Y but no current is measured at T1, T2, T3 motor sensors); CADM relay opens and RED LED is illuminated. TRIP condition maintains lockout of compressor operation until CADM is manually reset. Reset CADM by cycling unit main power.

Reversing valve solenoid remains de-energized until the next Cooling cycle is initiated.

Defrost Cycle —

During the Heating Mode, frost and ice can develop on the outdoor coil. Defrost sequence will clear the frost and ice from the coil by briefly reversing the Heating sequence periodically.

A window to test for a need to run the Defrost cycle opens at a fixed period after the end of the last Defrost cycle or the previous test window closed. The window period is determined by the configuration settings on the DFB's DIP switches (see unit wiring diagram).

If the outdoor coil's Defrost Thermostat switch (DFT) is closed (shorting DFB terminals DFT1 and DFT1), the Defrost cycle will start. Output at OF is removed; outdoor fans stop during the Defrost cycle. Output P3-7 (RVS1) is energized; reversing valve solenoid RVS is energized and reversing valve changes position, placing the circuit in a Cooling mode flow, directing hot gas into the outdoor coil where its heat melts the frost and loosens the ice on the coil face.

During the Defrost cycle, output EHEAT is also energized (if not already energized by a thermostat W2 demand); supplemental heater will be energized. During the Defrost Cycle, LED1 on the DFB will be illuminated. The Defrost cycle ends when DFT opens (as liquid temperature exiting the coil rises above DFT setpoint) or the defrost cycle runs for 10 minutes. Output at EHEAT is removed; supplemental heater will be de-energized (unless thermostat has a W2 demand). Output at OF is restored; outdoor fans start again.

Output P3-7 (RVS1) is removed; reversing valve returns to Heating position.

Defrost cycle is fixed at a maximum 10 minute duration limit. The period to test and initiate a Defrost cycle can be configured for 30, 60, 90 or 120 minutes.

Supplemental Heat/Emergency Heat —

Supplemental heat type is determined by FHS indoor unit options and accessories. This heat is initiated when the indoor unit W2 terminal is energized by the thermostat. (Or as detailed in “Defrost Cycle” on previous page.) The thermostat may energize W2 as supplemental (2nd stage) heat at larger space heating demand, or when selected as emergency heat mode. When the space heating demand decreases below the 2nd stage limit, or emergency heat is turned off, W2 is de-energized, and supplemental heat is turned off.

Cooling and Heating Shutdown —

Partial or complete cooling or heating functions may shutdown caused by loss of main power, open pressure switches, diagnostic alarms, or open internal compressor protections. See Service section for further details.

ROUTINE SYSTEM MAINTENANCE

These items should be part of a routine maintenance program, to be checked every month or two, until a specific schedule for each can be identified for this installation:

Quarterly Inspection (and 30 days after initial start) —

Indoor Section

- Coil cleanliness checked.
- Return air filter replacement
- Belt tension checked
- Belt condition checked
- Pulley alignment checked
- Fan shaft bearing locking collar tightness checked
- Condensate drain checked
- Blower motor amperage

Outdoor Section

- Fan motor mounting bolts tightness
- Compressor mounting bolts
- Fan blade positioning
- Control box cleanliness and wiring condition
- Wire terminal tightness
- Refrigerant charge level

Economizer or Outside Air Damper

- Inlet filters condition
- Check damper travel (economizer)
- Check gear and dampers for debris and dirt

SERVICE

Refrigeration System

⚠ CAUTION

EQUIPMENT DAMAGE HAZARD

Failure to follow this caution may result in damage to equipment .

This system uses R-410A refrigerant which has higher pressures than R-22 and other refrigerants. No other refrigerant may be used in this system. Gage set, hoses, and recovery system must be designed to handle R-410A. If you are unsure consult the equipment manufacturer.

Compressor Oil —

⚠ CAUTION

EQUIPMENT DAMAGE HAZARD

Failure to follow this caution may result in damage to equipment .

The compressor in a R-410A system uses a polyolester (POE) oil. This oil is extremely hygroscopic, meaning it absorbs water readily. POE oils can absorb 15 times as much water as other oils designed for HCFC and CFC refrigerants. Take all necessary precautions to avoid exposure of the oil to the atmosphere.

Servicing Systems on Roofs with Synthetic Materials —

POE (polyolester) compressor lubricants are known to cause long term damage to some synthetic roofing materials. Exposure, even if immediately cleaned up, may cause embrittlement (leading to cracking) to occur in one year or more. When performing any service which may risk exposure of compressor oil to the roof, take appropriate precautions to protect roofing. Procedures which risk oil leakage include but are not limited to compressor replacement, repairing refrigerants leaks, replacing refrigerant components such as filter drier, pressure switch, metering device, coil, accumulator, or reversing valve.

Synthetic Roof Precautionary Procedure:

1. Cover extended roof working area with an impermeable polyethylene (plastic) drop cloth or tarp. Cover an approximate 10 x 10 ft (3.3 x 3.3 m) area.
2. Cover area in front of the unit service panel with a terry cloth shop towel to absorb lubricant spills and prevent run-offs, and protect drop cloth from tears caused by tools or components.
3. Place terry cloth shop towel inside unit immediately under component(s) to be serviced and prevent lubricant run-offs through the louvered openings in the base pan.
4. Perform required service.

5. Remove and dispose of any oil contaminated material per local codes.

Liquid Line Filter Drier —

The factory-provided reversible filter drier is specifically designed to operate with R-410A. Replace the filter drier with factory-authorized components only with a filter drier with desiccant made from 100% molecular sieve grade XH-11. Filter drier must be replaced whenever the refrigerant system is opened.

When removing a filter drier, use a tubing cutter to cut the drier from the system. **Do not unsweat a filter drier** from the system. Heat from unsweating will release moisture and contaminants from drier into system.

Field Refrigerant Access Ports —

Field service access to refrigerant pressures is through the access ports located at the service valves. These ports are 1/4-in SAE Flare couplings with Schrader check valves and service caps. Use these ports to admit nitrogen to the field tubing during brazing, to evacuate the tubing and evaporator coil, to admit initial refrigerant charge into the low-side of the system and when checking and adjusting the system refrigerant charge. When service activities are completed, ensure the service caps are in place and secure; check for leaks. If the Schrader check valve must be removed and re-installed, tighten to 2-3 in-lbs (23-34 N-cm).

Outdoor Coil Metering Devices —

The metering devices are multiple fixed-bore devices swaged into the horizontal outlet tubes from the liquid header, located at the entrance to each evaporator coil circuit path. These are non-adjustable. Service requires replacing the entire liquid header assembly.

To check the indoor coil, disconnect the supply fan signal (A04-A06 direct-drive fans) or contactor (IFC) coil, then start the circuit in a Cooling Mode (jumper R to Y1 or Y2) and observe the frosting pattern on the face of the indoor coil. A frost pattern should develop uniformly across the face of the indoor coil starting at each tube at the Acutrol nipple locations.

To check the outdoor coil, disconnect the outdoor fan motor. Start the circuit in a Heating Mode (jumper R to W1 or W2) and observe the frost pattern on the face of the outdoor coil. Failure to develop frost at an outlet tube can indicate a plugged or a missing orifice.

Refrigerant System Pressure Access Ports —

There are two access ports in each circuit - on the suction tube near the compressor and on the discharge tube near the compressor. These are brass fittings with black plastic caps. The hose connection fittings are standard 1/4 SAE Male Flare couplings.

The brass fittings are two-piece High Flow valves, with a receptacle base brazed to the tubing and an integral spring-closed check valve core screwed into the base. (See Fig. 23.) This check valve is permanently assembled into this core body and cannot be serviced separately; replace the entire core body if necessary. Service tools are available that allow the replacement of the check valve core without having to recover the entire system refrigerant charge. Apply compressor refrigerant oil to the check valve core's bottom o-ring. Install the fitting body with 96 ±10 in-lbs (1085 ±23 N-cm) of torque; do not overtighten.

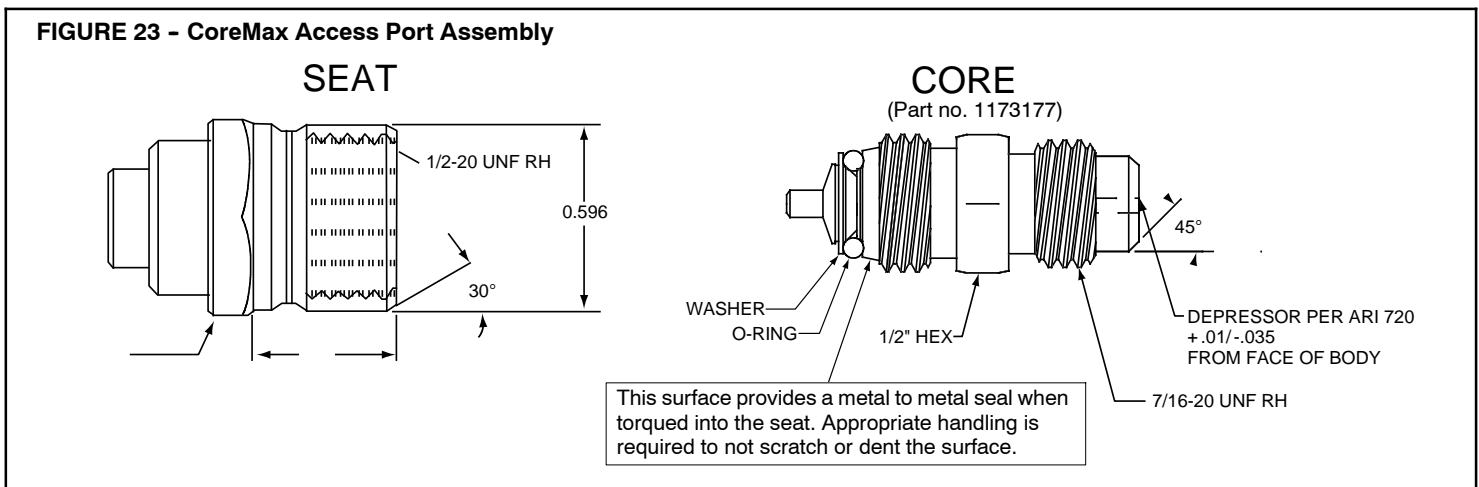

Compressor Protection

Compressor Overcurrent —

The compressor has internal limbered motor protection.

Compressor Overtemperature Protection (IP) —

The compressor has an internal protector to protect it against excessively high discharge gas temperatures.

Crankcase Heater —

The heater prevents refrigerant migration and compressor oil dilution during shutdown whenever compressor is not operating. The heater is wired to cycle with the compressor; the heater is off when compressor is running, and on when compressor is off.

The crankcase heater will operate as long as the power circuit is energized. The main disconnect must be on to energize the crankcase heater.

IMPORTANT: Never open any switch or disconnect that energizes the crankcase heater unless unit is being serviced or is to be shut down for a prolonged period. After a prolonged shutdown on a service job, energize the crankcase heater for 24 hours before starting the compressor.

High Pressure Switch —

The system is provided with a high pressure switch mounted on the discharge line. The switch is stem-mounted and brazed into the discharge tube. Trip setting is 630 ± 10 psig (4344 ± 69 kPa) when hot. Reset is automatic at 505 ± 20 psig (3482 ± 140 kPa).

Loss of Charge Switch —

The system is protected against a loss of charge and low evaporator coil loading condition by a loss of charge switch

located on the liquid line and a freeze protection thermostat on the indoor coil. The switch is stem-mounted. Loss of Charge Switch trip setting is 27 psig ± 3 psig (186 ± 21 kPa). Reset is automatic at 44 ± 5 psig (303 ± 35 kPa).

The factory installed loss of charge pressure switch (LOC) has open/close settings which do not provide indoor coil freeze protection. The control provides a location on terminal board TB2 to add a field supplied indoor coil freeze protection switch, if additional protection is wanted. The freeze protection switch can be wired into the 24VAC control circuit in series with the high pressure switch and loss of charge switch as shown in Fig. 24. Note that the wire to the compressor contactor must be moved from the LPS terminal to the FPT terminal, as shown.

A recommended indoor coil freeze protection switch is part # 1179253 ($30^\circ \pm 5^\circ\text{F}$ open, $45^\circ \pm 5^\circ\text{F}$ close) which can be mounted on a return bend of the indoor coil. For dual-circuits, a separate switch is used for each half of the indoor coil. And are wired as shown in Fig. 24.

Outdoor Fan Motor Protection —

The outdoor fan motor is internally protected against overtemperature.

Control Circuit, 24-V —

The control circuit is protected against overcurrent conditions by a circuit breaker mounted on control transformer TRAN. Reset is manual.

Commercial Defrost Control

The Commercial Defrost Control Board (DFB) coordinates thermostat demands for supply fan control, 1 or 2 stage cooling, 1 or 2 stage heating, emergency heating and defrost control with unit operating sequences. See Fig. 25 for board arrangement.

FIGURE 24 - Field Wiring of Indoor Coil Freeze Protection Switch (FPT) (Dual Circuit Shown)

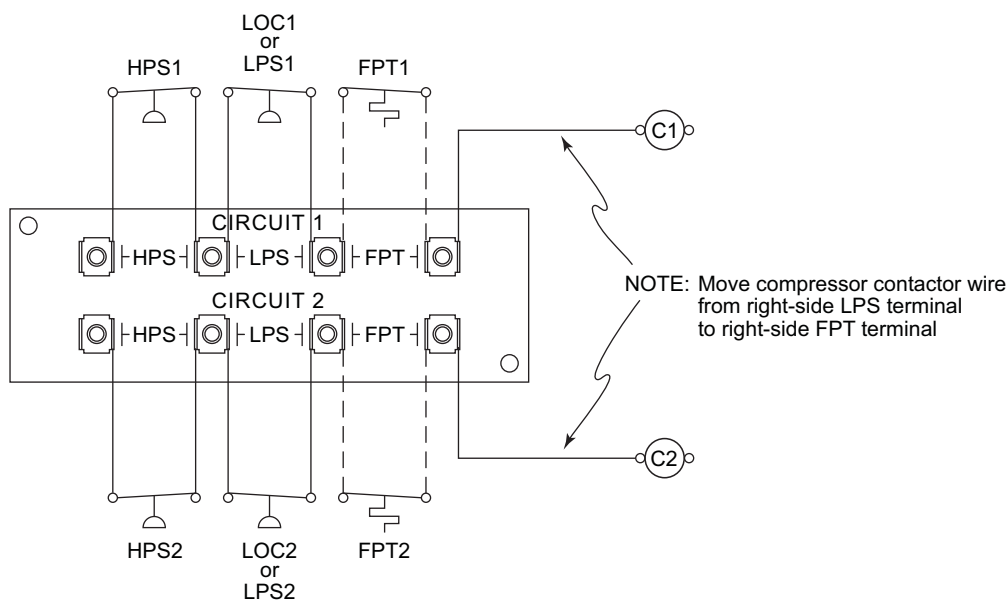

The DFB is located in the CHS's main control box (see Fig. 26). All connections are factory-wired. Refer to Table 7 for details of DFB Inputs and Outputs.

this application does not use an "O" or "B" signal to determine reversing valve position. Reversing valves are energized during the Cooling stages and de-energized during Heating cycles. Once energized at the start of a Cooling stage, the reversing valve will remain energized until the next Heating cycle demand is received. Once de-energized at the start of a Heating cycle, the reversing valves will remain de-energized until the next Cooling stage is initiated.

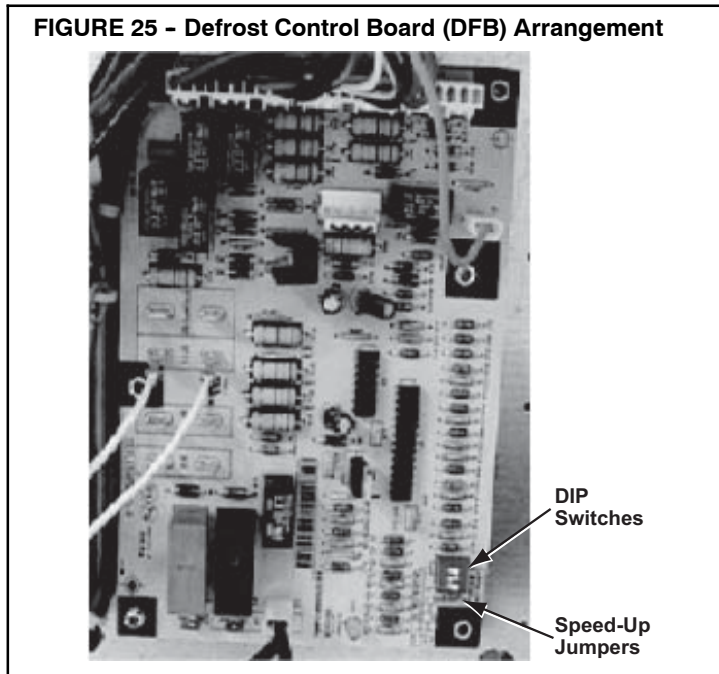

Compressor Control —

The DFB receives inputs indicating Stage 1 Cooling and Stage 1 Heating from the space thermostat; it generates commands to start compressors with or without reversing valve operation to produce Stage 1 Cooling (one compressor), or Stage 1 Heating (both compressors run).

Reversing Valve Control —

The DFB has two outputs for unit reversing valve control. Operation of the reversing valves is based on internal logic;

Table 7—CHS Defrost Board I/O and Jumper Configurations

Inputs				
Point Name	Type of I/O	Connection Pin Number	Unit Connection	Note
G Fan	DI, 24-vac	P2-3		Not used
Y1 Cool 1	DI, 24-vac	P2-5	TB-Y1	
Wi Heat 1	DI, 24-vac	P2-7	TB-W1	
R Power	24-vac	P3-1	TRAN2	
C Common	24-vac, ground	P3-3	TRAN2	
DFT1 Defrost Switch	DI, 24-vac	DFT-1 to DFT-1	DFB	
DFT2 Defrost Switch	DI, 24-vac	DFT-2 to DFT-2	DFB	
Outputs				
Point Name	Type of I/O	Connection Pin Number	Unit Connection	Note
OF OD Fan	DO, 24-vac	OF	OFR	
RVS1	DO, 24-vac	P3-7 to P3-5	RVS1	Energize in COOL
RVS2	DO, 24-vac	P3-6 to P3-4	RVS2	Energize in COOL
COMP 1	DO, 24-vac	P3-10	CADM1-Y	
TB-W2	DO, 24-vac	E-HEAT	HR	
Configuration				
Point Name	Type of I/O	Connection Pin Number	Unit Connection	Note
Select Jumper	24-vac	P1-1		
1 Compressor	24-vac	P1-2		
Speed-Up Configuration				
Point Name	Type of I/O	Connection Pin Number	Unit Connection	Note
Speed-Up Jumper		JMP17		
Speed-Up Jumper		JMP18		
Jumper for 1-3 secs: Factory Test, defrost runs for 12 seconds or less				
Jumper for 5-20 secs: Forced Defrost, defrost runs for 30 secs if DFT2 is open				

FIGURE 26 - Defrost Control Board (DFB) Location

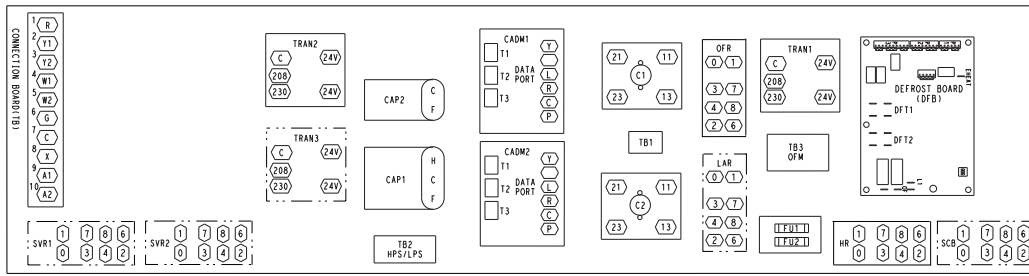

Defrost —

The defrost control mode is a time/temperature sequence. There are two time components: The continuous run period and the test/defrost cycle period. The temperature component is provided by the defrost thermostat (DFT1 and the DFT2) mounted on the outdoor coil.

The continuous run period is a fixed time period between the end of the last defrost cycle (or start of the current Heating cycle) during which no defrost will be permitted. This period can be set at 30, 60, 90 or 120 minutes by changing the positions of DIP switches SW1 and SW2 (see Fig. 27 and Table 8). The default run period is 60 minutes.

If the space heating load is satisfied and compressor operation is terminated, the defrost control will remember where the run period was interrupted. On restart in Heating, the defrost control will resume unit operation at the point in the run period where it was last operating.

Defrost Thermostats —

These are temperature switches that monitor the surface temperature of the outdoor coil circuits. These switches are mounted on the liquid tube exiting the outdoor coil heating circuits. These switches close on temperature drop at 30°F (-1°C) and reset open on temperature rise at 80°F (27°C).

Indoor Fan Off Delay —

The DFB can provide a 30 sec delay on Indoor Fan Off if the thermostat's fan selector switch is set on AUTO control. DIP Switch SW3 on the DFB selects use of the fan off time delay feature. Setting SW3 in the OPEN position turns the Fan Off Delay feature on; setting SW3 in the CLOSED position disables this feature. The delay period begins when Y1 demand or W1 demand by the space thermostat is removed.

Defrost Speedup Functions —

The DFB permits the servicer to speed-up the defrost cycle. There are two speed-up sequences: relative speed-up and an immediate forced defrost. Speed-up sequences are initiated by shorting jumper wires JMP17 and JMP18 together (see Fig. 25); use a straight-edge screwdriver.

Shorting the jumpers for a period of 1 to 3 secs reduces the defrost timer periods by a factor of 0.1 sec/minute. (For example, the 90 min run period is reduced to 9 secs.) The DFB will step the unit through a Heating cycle and a Defrost cycle using these reduced time periods. This mode ends after the Defrost cycle.

Shorting the jumpers for a period of 5 to 20 secs bypasses the remaining continuous run period and places the unit in a Forced Defrost mode. If the controlling DFT is closed when this mode is initiated, the unit will complete a normal defrost period that will terminate when the controlling DFT opens or the 10 minute defrost cycle limit is reached. If the controlling DFT is open when this mode is initiated, the Defrost cycle will run for 30 secs. Both modes end at the end of the Defrost cycle.

FIGURE 27 - DIP Switch Settings - Defrost Board

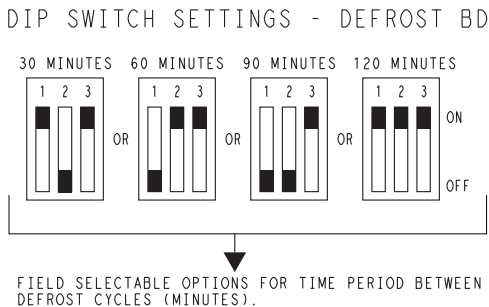

At the end of the continuous run period, the defrost control will test for a need to defrost. DFT2 (located on the bottom circuit of the outdoor coil) controls the start and termination of the defrost cycle. If DFT2 is still open, the defrost test/run window is closed and the control repeats the continuous run period. If DFT2 is closed, the defrost cycle is initiated in Circuit 2. The defrost period will end when DFT2 opens (indicating the outdoor coil has been clear of frost and ice) or a 10 minute elapsed period expires, whichever comes first.

Circuit 1's defrost thermostat DFT1 (located on the upper circuit of the outdoor coil) cannot initiate a unit defrost cycle; only DFT2 may do this. But once Circuit 2 is in defrost, the DFB will monitor the status of DFT1. If DFT1 closes during a Circuit 2 defrost cycle, Circuit 1 will also enter a defrost cycle. Circuit 1's defrost cycle will end when DFT1 opens (indicating the upper portion of the outdoor coil is cleared of frost and ice) or the Circuit 2 defrost cycle is terminated.

At the end of the unit defrost cycle, the unit will be returned to Heating cycle for a full continuous run period.

Table 8—Dip Switch Position

Switch No.														
	1	2		1	2		1	2		1	2		3	
1	■		1		■	1			1	■	■	1		On
0		■	0	■		0	■	■	0			0	■	Off
	30 minutes			60 minutes			90 minutes			120 minutes			Fan Delay	

FIGURE 28 - CHS180 Exterior

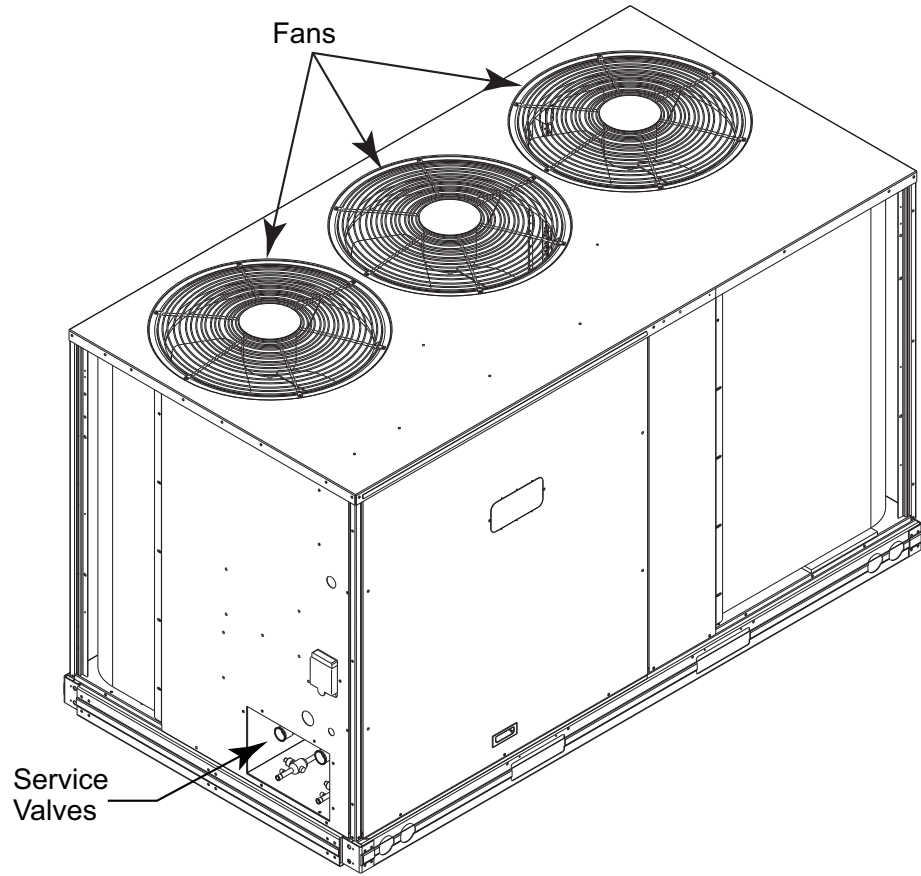

FIGURE 29 - CHS180 Interior

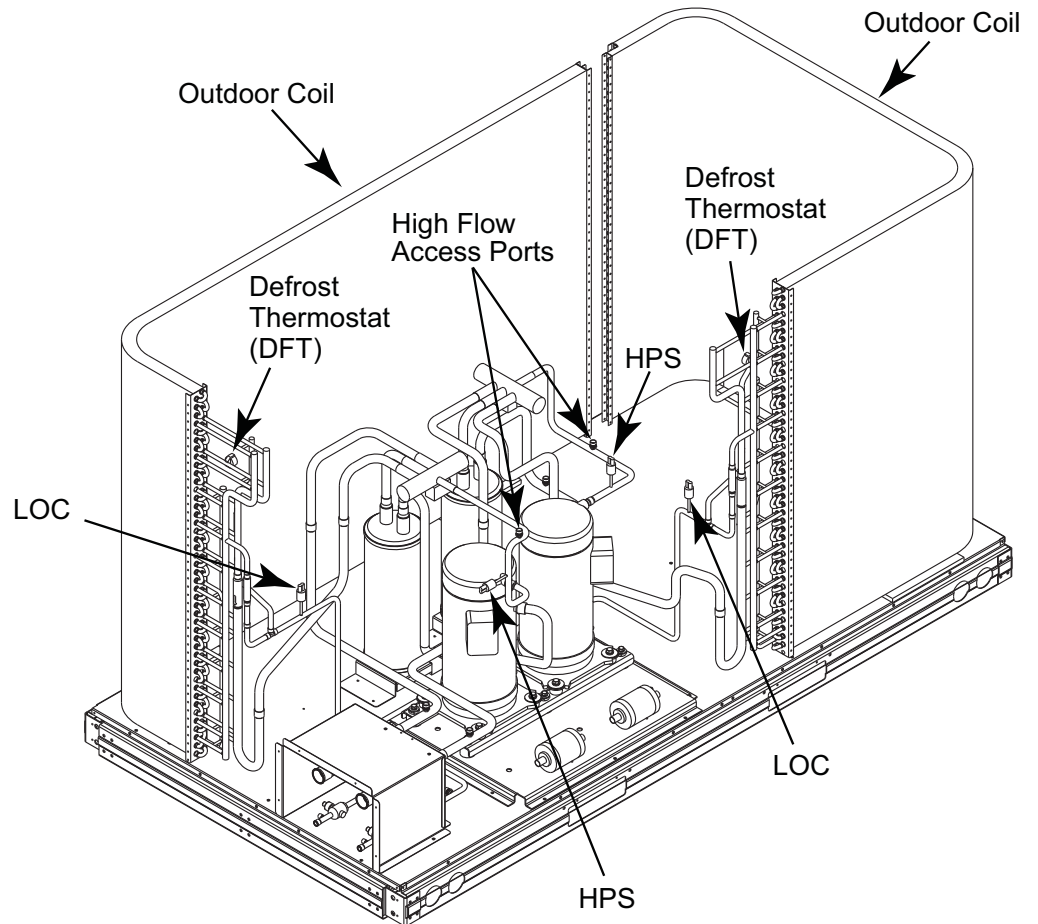

FIGURE 30 - CHS240 Exterior

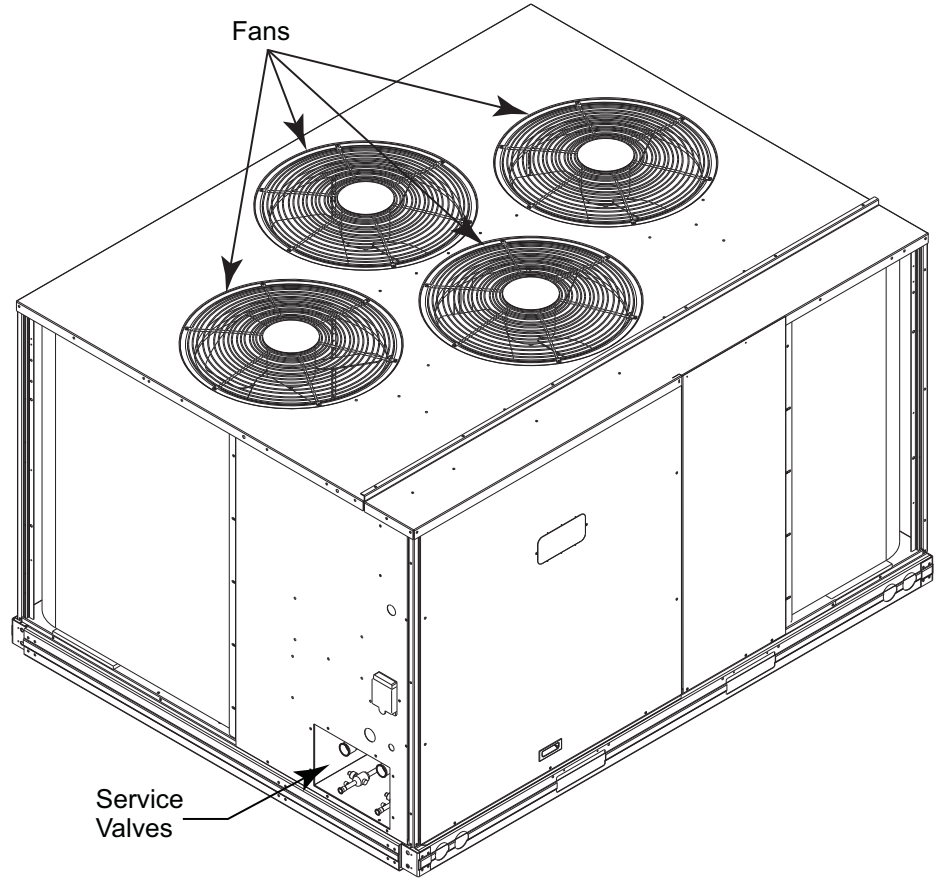
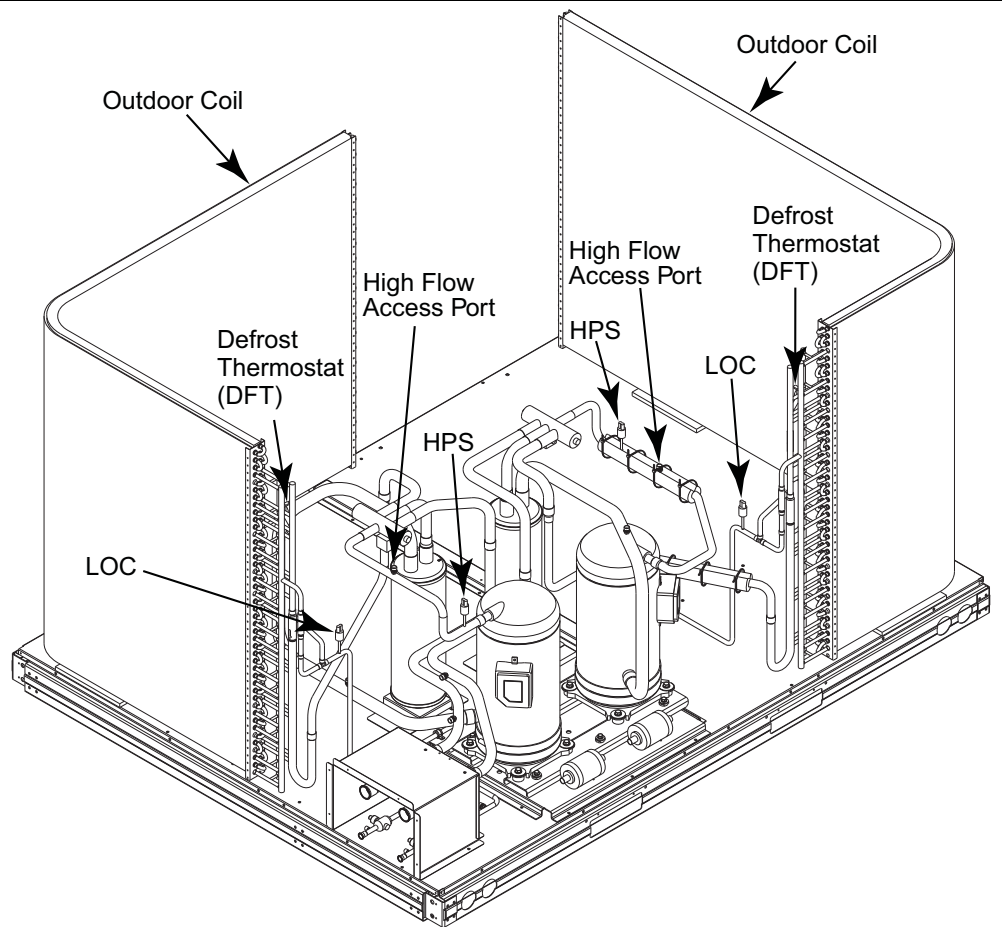

FIGURE 31 - CHS240 Interior



Comfort Alert Diagnostic Module

The Comfort Alert Diagnostic Module (CADM) monitors and analyzes data from the Copeland Scroll® three-phase compressor and the thermostat demand. The CADM also provides a 3-minute anti-recycle time delay to compressor cycling.

The CADM detects causes for electrical and system related failures. Flashing LEDs communicate the Alert codes to guide service technicians in accurately and quickly troubleshooting the system and determining root cause for the failure.

Inputs to the CADM include 24-vac power, demand signal Y, compressor contactor coil (common side) and compressor power leads (from the compressor contactor).

Input	Terminal	Voltage
Control Power	R	24-V
Control Common	C	24-V
Demand	Y	24-V
Contacting Coil	P	24-V
Compressor T1	T1	Line
Compressor T2	T2	Line
Compressor T3	T3	Line

Control of the compressor contactor coil is through a contact between terminals P and C.

Communications of status and alert conditions is through three LEDs located on the top edge of the module housing (see Fig. 32): POWER (green), ALERT (yellow), and TRIP (red).

The POWER LED indicates the presence of control power to the CADM.

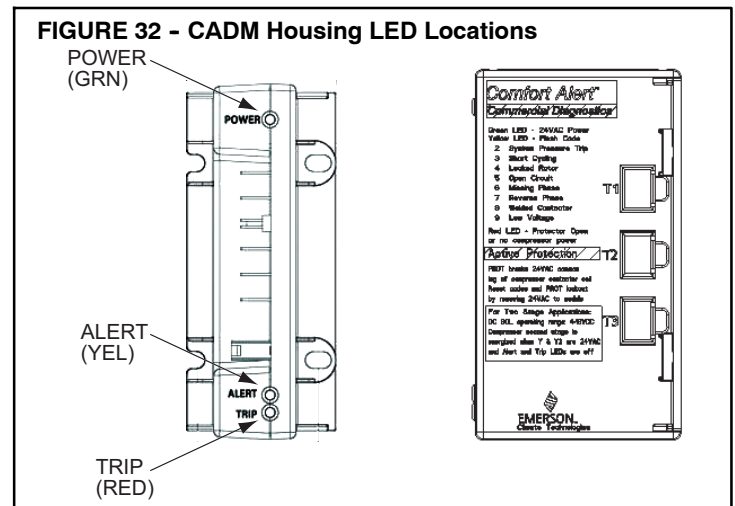

The ALERT LED indicates an abnormal condition exists in the system through a flash code. The ALERT LED will blink a number of times consecutively, pause and then repeat the process. The number of blinks, defined in Table 10, correlates to a particular abnormal condition; troubleshooting tips are provided for each Alert code. Reset of the ALERT may be automatic or manual. If the fault condition causing the Alert is self-corrected, the Alert code will be removed and the CADM will automatically reset and allow the system to restart normally. Manual reset for lockouts requires that main power to the CHS unit be recycled after the cause for the Alert condition has been detected and corrected.

The TRIP LED indicates either a time-delay period is currently active (RED LED is blinking) or the module has locked out the compressor (RED LED is on steady). A lockout condition will occur for some faults as identified in Table 10. Reset of the TRIP LED requires that unit main power be recycled after the loss of power to the compressor condition has been detected and corrected.

Simultaneous Blinking of YELLOW and RED LEDs indicates control power input to the CADM is low. Check control circuit transformer and wiring.

Troubleshooting the CADM Wiring – Flashing LEDs also indicate wiring problems to the CADM. See Table 9 for discussion of additional LED flash codes and troubleshooting instructions.

Table 9—LED Status Codes

Status LED	Status LED Description	Status LED Troubleshooting Information
Green "POWER"	Module has power	Supply voltage is present at module terminals
Red "TRIP" LED On Solid	Thermostat demand signal Y is present, but the compressor is not running.	<ol style="list-style-type: none"> 1. Compressor protector is open 2. Condensing unit power disconnect is open 3. Compressor circuit breaker or fuse(s) is open 4. Broken supply wires or connector is not making contact 5. Compressor power wires not routed through Comfort Alert 6. Compressor contactor has failed open
Red "TRIP" LED Flashing	The anti-short cycle timer (3 minutes), in module is preventing compressor restart.	
Module locks out compressor when compressor damaging ALERT code appears. Lockout ALERT codes are noted in the Status LED Description. During a compressor lock out, 24VAC power must be removed from module to manually reset.		
Yellow "ALERT" LED On Solid	A short circuit or over current condition exists on PROT terminal.	<ol style="list-style-type: none"> 1. Compressor contactor coil shorted 2. Electrical load too high for PROT circuit (maximum 1 Amp) 3. 24 V AC wired directly to PROT terminal
Yellow "ALERT" Flash Code 2	System Pressure Trip Discharge pressure out of limits or compressor over-load (if no high pressure switch in system) LOCKOUT	<ol style="list-style-type: none"> 1. High head pressure 2. Condenser coil poor air circulation (dirty, blocked, damaged) 3. Condenser fan is not running 4. If low pressure switch is open: Refer to Code 3 for troubleshooting
Yellow "ALERT" Flash Code 3	Short Cycling Compressor is running only briefly LOCKOUT	<ol style="list-style-type: none"> 1. If low pressure switch is open: <ol style="list-style-type: none"> a. Low refrigerant charge b. Evaporator blower is not running c. Evaporator coil is frozen d. Faulty metering device e. Condenser coil is dirty f. Liquid line restriction (filter drier blocked if present) 2. If high pressure switch is open, go to Flash Code 2 information 3. Intermittent thermostat demand signal 4. System or control board defective
Yellow "ALERT" Flash Code 4	Locked Rotor LOCKOUT	<ol style="list-style-type: none"> 1. Low line voltage to compressor 2. Excessive liquid refrigerant in compressor 3. Compressor bearings are seized
Yellow "ALERT" Flash Code 5	Open Circuit	<ol style="list-style-type: none"> 1. Condensing unit power disconnect is open 2. Compressor circuit breaker or fuses are open 3. Compressor contactor has failed open 4. High pressure switch is open and requires manual reset 5. Broken supply wires or connector is not making contact 6. Unusually long compressor protector reset time due to extreme ambient temperature 7. Compressor windings are damaged
Yellow "ALERT" Flash Code 6	Missing Phase LOCKOUT	<ol style="list-style-type: none"> 1. Compressor fuse is open on one phase 2. Broken wire or connector on one phase 3. Compressor motor winding is damaged 4. Utility supply has dropped one phase
Yellow "ALERT" Flash Code 7	Reverse Phase LOCKOUT	<ol style="list-style-type: none"> 1. Compressor running backward due to supply phase reversal
Yellow "ALERT" Flash Code 8	Welded Contactor Compressor always runs	<ol style="list-style-type: none"> 1. Compressor contactor has failed closed 2. Thermostat demand signal not connected to module
Yellow "ALERT" Flash Code 9	Low Voltage Control circuit < 18VAC	<ol style="list-style-type: none"> 1. Control circuit transformer is overloaded 2. Low line voltage to compressor

Table 10—CADM Troubleshooting

Miswired Module Indication	Recommended Troubleshooting Action
Green LED is not on, module does not power up	Determine if both R and C module terminals are connected. Verify voltage is present at module's R and C terminals. NOTE: The CADM requires a constant nominal 24VAC power supply. The wiring to the module's R and C terminals must be directly from the control transformer. The module cannot receive its power from another device that will interrupt the 24VAC power supply. See Figs. 18 and 19, the CHS Wiring Diagram.
Green LED Intermittent, module powers up only when compressor runs	Determine if R and Y terminals are wired in reverse. Verify module's R and C terminals have a constant source. See "NOTE" above for details on R and C wiring.
TRIP LED is on but system and compressor check OK	Verify Y terminal is wired properly per the CHS wiring diagram (see Figs. 18 and 19). Verify voltage at contactor coil falls below 0.5VAC when off. Verify 24VAC is present across Y and C when thermostat demand signal is present. If not, R and C are reverse wired.
TRIP LED and ALERT LED flashing together	Verify R and C terminals are supplied with 19-28VAC.
ALERT Flash Code 3 (Compressor Short Cycling) displayed incorrectly	Verify Y terminal is connected to 24VAC at contactor coil. Verify voltage at contactor coil falls below 0.5VAC when off.
ALERT Flash Code 5 or 6 (Open Circuit, Missing Phase) displayed incorrectly	Check that compressor T1 and T3 wires are through module's current sensing holes. Verify Y terminal is connected to 24VAC at contactor coil. Verify voltage at contactor coil falls below 0.5VAC when off.
Alert Flash Code * (Welded Contactor) displayed incorrectly	Determine if module's Y terminal is connected. Verify Y terminal is connected to 24VAC at contactor coil. Verify 24VAC is present across Y and C when thermostat demand signal is present. If not, R and C are reverse wired. Verify voltage at contactor coil falls below 0.5VAC when off.

Outdoor Fans

Each fan is supported by a formed-wire mount bolted to the fan deck and covered with a wire guard. Fan motors have permanently lubricated bearings.

1. Shut off unit power supply. Install lockout tag.
2. Remove outdoor fan assembly (grille, motor, and fan).
3. Loosen fan hub setscrews.
4. Adjust fan height as shown in Fig. 33.
5. Tighten setscrews to 84 in.-lbs (949 N-cm).
6. Replace outdoor fan assembly.

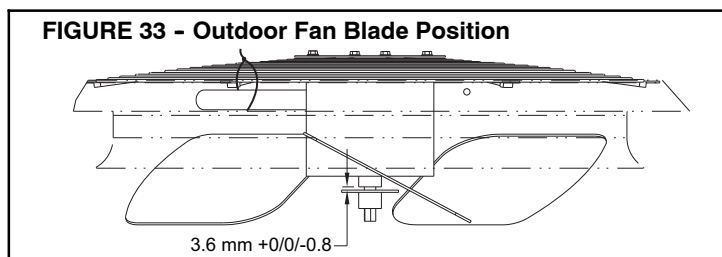

Lubrication

Fan Motors —

The fan motors have sealed bearings. No provisions are made for lubrication.

Compressor —

The compressor has its own oil supply. Loss of oil due to a leak in the system should be the only reason for adding oil after the system has been in operation.

Outdoor Coil Maintenance and Cleaning Recommendation

Routine cleaning of coil surfaces is essential to maintain proper operation of the unit. Elimination of contamination and removal of harmful residues will greatly increase the life of the coil and extend the life of the unit. The following maintenance and cleaning procedures are recommended as part of the routine maintenance activities to extend the life of the coil.

Remove Surface Loaded Fibers —

Surface loaded fibers or dirt should be removed with a vacuum cleaner. If a vacuum cleaner is not available, a soft non-metallic bristle brush may be used. In either case, the tool should be applied in the direction of the fins. Coil surfaces can be easily damaged (fin edges can be easily bent over and damage the coating of a protected coil) if the tool is applied across the fins.

NOTE: Use of a water stream, such as a garden hose, against a surface loaded coil will drive the fibers and dirt into the coil. This will make cleaning efforts more difficult. Surface loaded fibers must be completely removed prior to using low velocity clean water rinse.

Periodic Clean Water Rinse —

A periodic clean water rinse is very beneficial for coils that are applied in coastal or industrial environments. However, it is very important that the water rinse is made with very low velocity water stream to avoid damaging the fin edges. Periodic cleaning as described below is recommended.

⚠ CAUTION

PERSONAL INJURY AND UNIT DAMAGE HAZARD

Failure to follow this caution may result in personal injury or equipment damage.

Only approved cleaning is recommended.

Routine Cleaning of Indoor Coil Surfaces —

Periodic cleaning with environmentally sound coil cleaner is essential to extend the life of coils. This cleaner is available from *FAST* as part number 1178704 for one gallon container, and part number 1178705 for a 5 gallon container. It is recommended that all coils, including standard aluminum, pre-coated, copper/copper or E-coated coils be cleaned with the environmentally sound coil cleaner as described below. Coil cleaning should be part of the unit's regularly scheduled maintenance procedures to ensure long life of the coil. Failure to clean the coils may result in reduced durability in the environment.

Avoid the use of:

- coil brighteners
- acid cleaning prior to painting
- high pressure washers
- poor quality water for cleaning

Environmentally sound coil cleaner is nonflammable, hypoallergenic, non bacterial, and a USDA accepted biodegradable agent that will not harm the coil or surrounding components such as electrical wiring, painted metal surfaces, or insulation. Use of non-recommended coil cleaners is strongly discouraged since coil and unit durability could be affected.

Environmentally Sound Coil Cleaner Application Equipment:

- 2¹/₂ gallon garden sprayer
- Water rinse with low velocity spray nozzle

⚠ CAUTION

UNIT DAMAGE HAZARD

Failure to follow this caution may result in corrosion and damage to the unit .

Harsh chemicals, household bleach or acid or basic cleaners should not be used to clean outdoor or indoor coils of any kind. These cleaners can be very difficult to rinse out of the coil and can accelerate corrosion at the fin/tube interface where dissimilar materials are in contact. If there is dirt below the surface of the coil, use the Totaline environmentally sound coil cleaner as described above.

⚠ CAUTION

UNIT RELIABILITY HAZARD

Failure to follow this caution may result in reduced unit performance .

High velocity water from a pressure washer, garden hose, or compressed air should never be used to clean a coil. The force of the water or air jet will bend the fin edges and increase airside pressure drop.

Environmentally Sound Coil Cleaner Application Instructions:

NOTE:Proper eye protection such as safety glasses is recommended during mixing and application.

1. Turn off unit power.
2. Remove screws holding rear corner post and top cover in place. Pivot top cover up 12 to 18 inches (305 to 457 mm) and support with a rigid support. See Fig. 34.

FIGURE 34 - Pivot and Support Top Cover

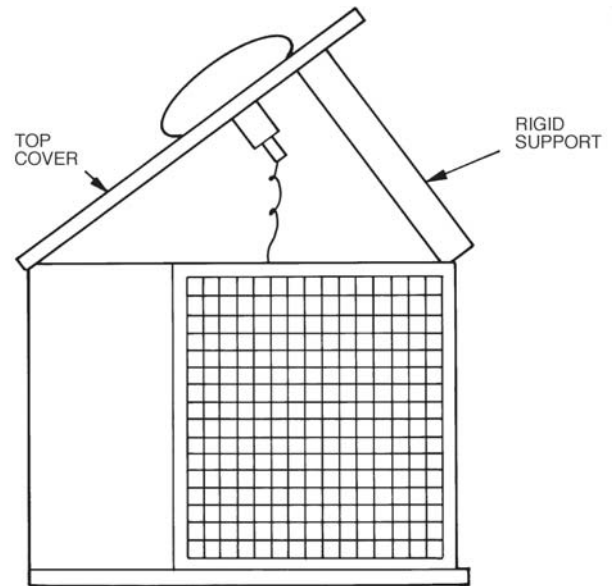

3. Remove all surface loaded fibers and dirt with a vacuum cleaner. If a vacuum cleaner is not available, a soft non-metallic bristle brush may be used. In either case, the tool should be applied in the direction of the fins. Coil surfaces can be easily damaged (fin edges can be easily bent over and damage to the coating of a protected coil) if the tool is applied across the fins.

NOTE:Use of a water stream, such as a garden hose, against surface loaded coil will drive the fibers and dirt into the coil, making cleaning efforts more difficult. Surface loaded fibers must be completely removed prior to using low velocity clean water rinse.

4. Using a low velocity garden hose thoroughly wet finned surfaces with clean water. Be careful not to bend the fins.
5. Mix environmentally sound coil cleaner in a 2¹/₂ gallon garden sprayer according to the instructions included with the cleaner. The optimum solution temperature is 100°F (38°C).

NOTE: Do NOT USE water in excess of 130°F (54°C), as the enzymatic activity will be destroyed.

6. Thoroughly apply environmentally sound coil cleaner solution to all coil surfaces including the finned area, tube sheets and coil headers.
7. Hold garden sprayer nozzle close to finned areas and apply cleaner with a vertical, up-and-down motion. Avoid spraying in horizontal pattern to minimize potential for fin damage.
8. Ensure cleaner thoroughly penetrates deep into finned areas.
9. Interior and exterior finned areas must be thoroughly cleaned.
10. Finned surfaces should remain wet with cleaning solution for 10 minutes.
11. Ensure surfaces are not allowed to dry before rinsing. Reapply cleaner as needed to ensure 10-minute saturation is achieved.
12. Thoroughly rinse all surfaces with low velocity clean water using downward rinsing motion of water spray nozzle. Protect fins from damage from the spray nozzle.
13. Replace top cover and rear corner posts.

Service Parts

Listings of service parts for all units are available from the FAST Parts Catalog

FASTENER TORQUE VALUES

Table 11—Torque Values

Compressor mounting bolts	65–75 in–lbs (734–847 N–cm)
Condenser fan motor mounting bolts	20 ±2 in–lbs (226 ±23 N–cm)
Condenser fan hub setscrew	84 ±2 in–lbs (949 ±136 N–cm)
High-flow service port	96 ±10 in–lbs (1085 ±23 N–cm)
Schrader-type service check valve	2–3 in–lbs (23–34 N–cm)
Compressor oil sightglass thread	330 ±31 in–lbs (23–34 N–cm)
Compressor to Compressor rail torque	120–168 in–lbs (1356–1898 N–cm)
Compressor rail to base pan torque	70 ±5 in–lbs (791 ±57 N–cm)

TROUBLESHOOTING

PROBLEM	CAUSE	REMEDY
Compressor and Outdoor Fan Will Not Start.	Power failure.	Call power company.
	Fuse blown or circuit breaker tripped.	Replace fuse or reset circuit breaker. Determine root cause.
	Defective thermostat, contactor, transformer, control relay, or capacitor.	Replace component.
	Insufficient line voltage.	Determine cause and correct.
	Incorrect or faulty wiring.	Check wiring diagram and rewire correctly.
	Thermostat setting too high.	Lower thermostat setting below room temperature.
	High pressure switch tripped.	See problem "Excessive head pressure."
	Low pressure switch tripped.	Check system for leaks. Repair as necessary.
	Freeze-up protection thermostat tripped.	See problem "Suction pressure too low."
Compressor Will Not Start But Outdoor Fan Runs.	Faulty wiring or loose connections in compressor circuit.	Check wiring and repair or replace.
	Compressor motor burned out, seized, or internal overload open.	Determine cause. Replace compressor or allow enough time for internal overload to cool and reset.
	Defective run/start capacitor, overload, start relay.	Determine cause and replace compressor.
	One leg of 3-phase power dead.	Replace fuse or reset circuit breaker. Determine cause.
Compressor Cycles (Other Than Normally Satisfying Thermostat).	Refrigerant overcharge or undercharge.	Recover refrigerant, evacuate system, and recharge to nameplate.
	Defective compressor.	Replace and determine cause.
	Insufficient line voltage.	Determine cause and correct.
	Blocked outdoor coil or dirty air filter.	Determine cause and correct.
	Defective run/start capacitor, overload, or start relay.	Determine cause and replace.
	Defective thermostat.	Replace thermostat.
	Faulty outdoor-fan (cooling) or indoor-fan (heating) motor or capacitor.	Replace.
	Restriction in refrigerant system.	Locate restriction and remove.
Compressor Operates Continuously.	Dirty air filter.	Replace filter.
	Unit undersized for load.	Decrease load or increase unit size.
	Thermostat set too low (cooling).	Reset thermostat.
	Low refrigerant charge.	Locate leak; repair and recharge.
	Air in system.	Recover refrigerant, evacuate system, and recharge.
	Outdoor coil dirty or restricted.	Clean coil or remove restriction.
Compressor Makes Excessive Noise.	Compressor rotating in the wrong direction.	Reverse the 3-phase power leads as described in Start-Up.
Excessive Head Pressure.	Dirty outside air or return air filter (heating).	Replace filter.
	Dirty outdoor coil (cooling).	Clean coil.
	Refrigerant overcharged.	Recover excess refrigerant.
	Air in system.	Recover refrigerant, evacuate system, and recharge.
	Condensing air restricted or air short-cycling.	Determine cause and correct.
Head Pressure Too Low.	Low refrigerant charge.	Check for leaks; repair and recharge.
	Compressor scroll plates defective.	Replace compressor.
	Restriction in liquid tube.	Remove restriction.
Excessive Suction Pressure.	High heat load.	Check for source and eliminate.
	Compressor scroll plates defective.	Replace compressor.
	Refrigerant overcharged.	Recover excess refrigerant.
Suction Pressure Too Low.	Dirty air filter (cooling).	Replace filter.
	Dirty or heavily iced outdoor coil (heating).	Clean outdoor coil. Check defrost cycle operation.
	Low refrigerant charge.	Check for leaks; repair and recharge.
	Metering device or low side restricted.	Remove source of restriction.
	Insufficient indoor airflow (cooling mode).	Increase air quantity. Check filter and replace if necessary.
	Temperature too low in conditioned area.	Reset thermostat.
	Field-installed filter drier restricted.	Replace.
	Outdoor ambient below 25°F (cooling).	Install low-ambient kit.
	Outdoor fan motor(s) not operating (heating).	Check fan motor operation.

APPENDIX A

AIR CONDITIONER AND HEAT PUMP WITH R-410A — QUICK REFERENCE GUIDE

- R-410A refrigerant operates at 50 percent to 70 percent higher pressures than R-22. Be sure that servicing equipment and replacement components are designed to operate with R-410A.
- R-410A refrigerant cylinders are rose colored.
- Recovery cylinder service pressure rating must be 400 psig, DOT 4BA400 or DOT BW400.
- R-410A systems should be charged with liquid refrigerant. Use a commercial type metering device in the manifold hose when charging into suction line with compressor operating.
- Manifold sets should be 700 psig high side and 180 psig low side with 550 psig low-side retard.
- Use hoses with 700 psig service pressure rating.
- Leak detectors should be designed to detect HFC refrigerant.
- R-410A, as with other HFCs, is only compatible with POE oils.
- Vacuum pumps will not remove moisture from oil.
- Use only factory specified liquid-line filter driers with rated working pressures greater than 600 psig.
- Do not install a suction-line filter drier in liquid-line.
- POE oils absorb moisture rapidly. Do not expose oil to atmosphere.
- POE oils may cause damage to certain plastics and roofing materials.
- Wrap all filter driers and service valves with wet cloth when brazing.
- A factory approved, liquid-line filter drier is required on every unit.
- Do not use an R-22 TXV.
- If indoor unit is equipped with a TXV, it must be changed to a R-410A TXV.
- Never open system to atmosphere while it is under a vacuum.
- When system must be opened for service, recover refrigerant, break vacuum with dry nitrogen before opening system.
- Always replace filter drier after opening system for service.
- Do not vent R-410A into the atmosphere.
- Do not use capillary tube coils.
- Observe all **warnings**, **cautions**, and **bold** text.
- All R-410A heat pumps must have indoor TXV.
- Do not leave R-410A suction line driers in place for more than 72 hours.

APPENDIX B

Low Ambient Option — Factory Installed

Units with the factory installed low ambient option are equipped with a Motormaster® solid-state head pressure control which regulates fan speed. A temperature sensor, mounted on circuit 1 of the outdoor coil (see Figs. 35 and 36) controls the speed of approved outdoor fan motors in order to maintain a constant head pressure in the outdoor coil. The control maintains the appropriate head pressure at low ambient temperatures down to -20°F (-28°C).

Wind baffles are required to prevent wind cross currents from causing abnormally low condensing temperatures.

- Use 20-gauge sheet metal to fabricate wind baffles (see Fig. 37 and Table 13) and mounting brackets (see Fig. 38).

NOTE: Mounting brackets are for use on 15 ton model units only.

- Install the wind baffles as show in Fig. 39, for 15 ton units and Fig. 40, for 20 ton units .

Operation —

Fan on/off control in cooling-only units is provided by an outdoor fan relay (OFR).

In cooling mode, fan motor speed of outdoor motors OFM1 and OFM3 is regulated by the speed control temperature sensor on outdoor coil 1 for a minimum coil condensing temperature of approximately 100°F (38°C) at higher outdoor ambient temperature and 80°F (27°C) at lower ambient. Additionally, outdoor fan motor OFM2 and OFM4 are turned on/off by the low ambient temperature switch, LAS, operating the low ambient relay (LAR). The LAS control temperatures are open 42°F +/- 5°F, close 57°F +/- 5°F (open 5.5°C +/- 2.8°C, close 13.9°C +/- 2.8°C).

To override the speed control for full fan speed operation during service or maintenance, either:

- remove sensor and place in hot water >120°F (>49°C), or
- rewire to bypass control by connecting speed control input and output power wires.

Troubleshooting —

OBSERVATION	POSSIBLE REMEDY
Fans won't start	All fans: Check power & wiring Check outdoor fan relay (OFR) OFM1, OFM3 only: Check speed control sensor location Check speed sensor resistance OFM2, OFM4 only: Check low ambient switch (LAS) Check low ambient relay (LAR)
Cooling – Center outdoor fans (OFM2, OFM4) off below approximately 60°F (16°C) outdoor ambient.	Normal operation
Cooling – Center outdoor fans (OFM2, OFM4) not on above approximately 60°F (16°C) outdoor ambient	Check low ambient switch (LAS) Check low ambient relay (LAR)
Cooling – Slow fan speed for outer fans (OFM1, OFM3) at start or during low outdoor ambient	Normal operation
Cooling – Slow fan speed for outer fans (OFM1, OFM3) above 85°F (29°F) outdoor ambient (should be full speed)	Check speed control sensor location Check speed control sensor resistance Check fan motor capacitor
Cooling – motor current into speed control is greater than motor name-plate FLA	Normal operation Up to 30% higher A at partial speed at low ambient

Speed Control Sensor Resistance —

TEMPERATURE		RESISTANCE
°F +/- 2°F°	°C +/- 1C	Ohms, nominal
-22	-30	88350
-4	-20	48485
14	-10	27650
32	0	16325
50	10	9950
68	20	6245
77	25	5000
86	30	4028
104	40	2663
122	50	1801
140	60	1244
158	70	876

FIGURE 35 - Motormaster Sensor Location:CHS180

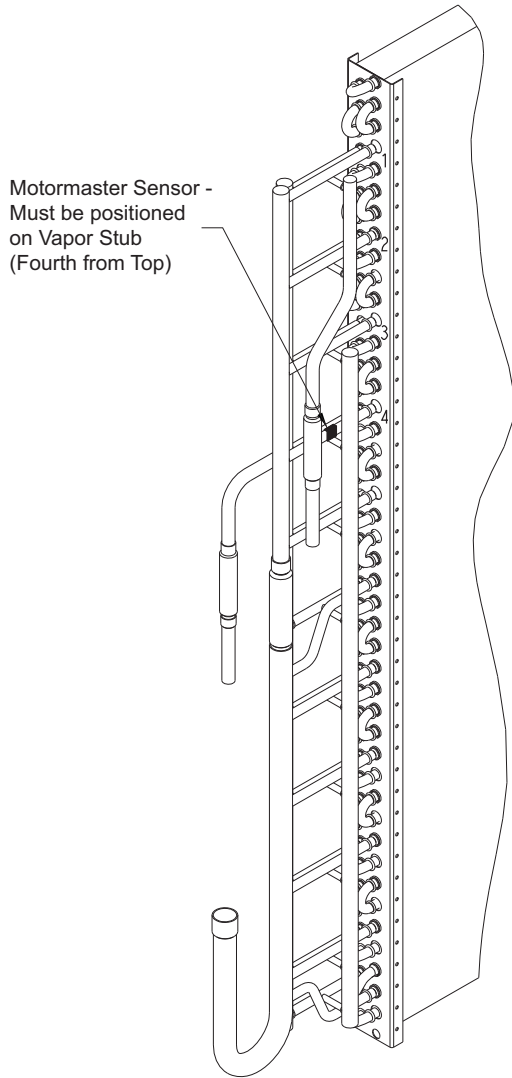

FIGURE 36 - Motormaster Sensor Location:CHS240

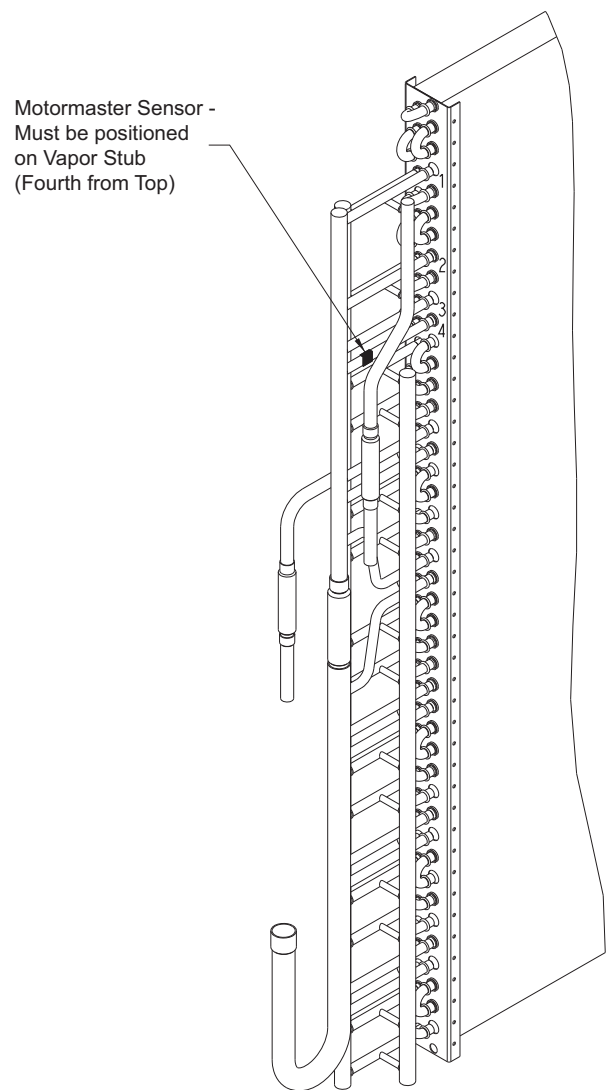
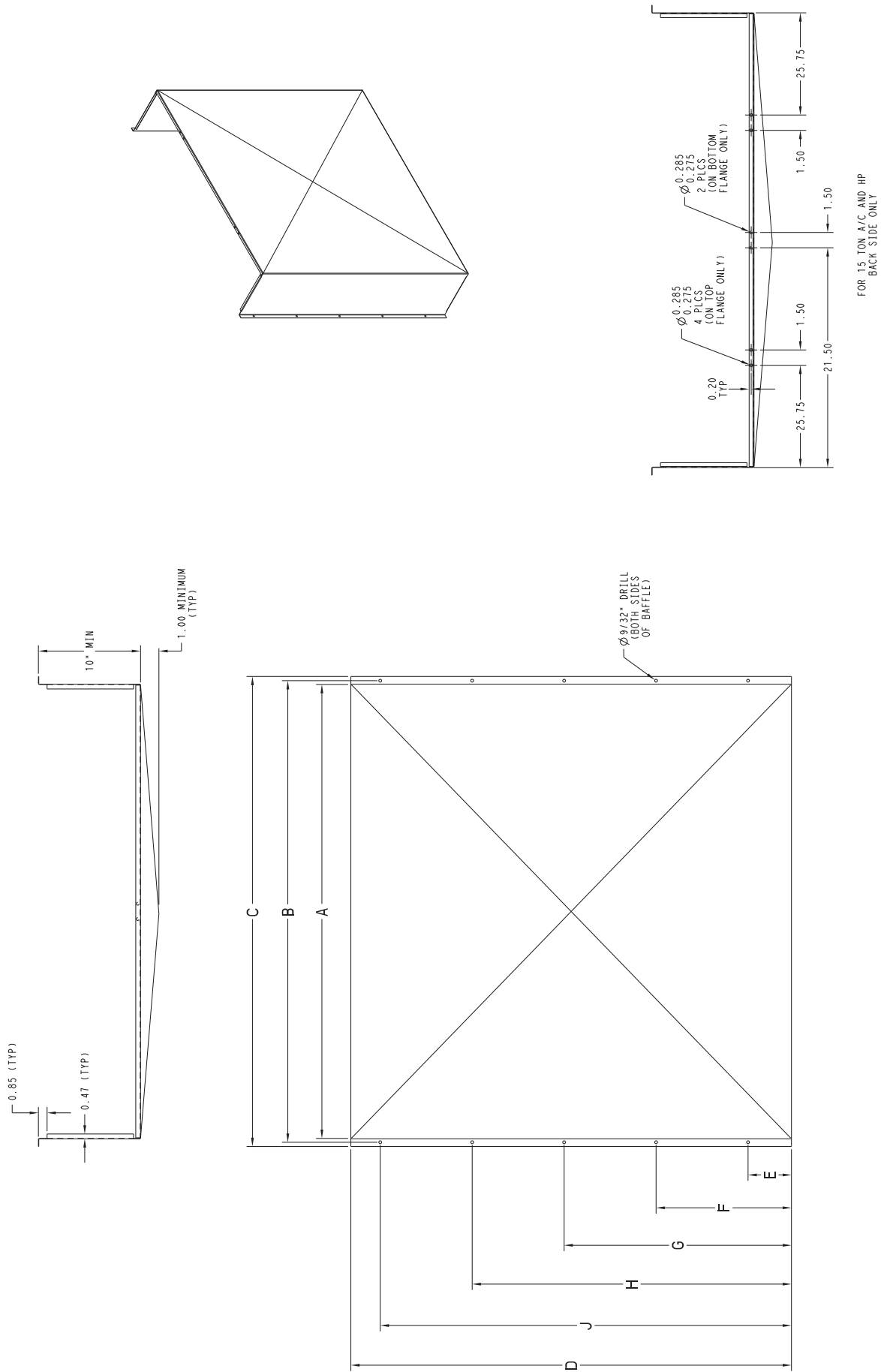

Table 12—Wind Baffle Dimension

DIMENSIONS - INCHES										
UNIT	BAFFLE	A	B	C	D	E	F	G	H	J
CHS180	LEFT SIDE	19 3/4	20 1/2	21 1/4	43 1/8	8 3/8	18	27 1/4	40	-
	BACK	80 1/4	81	81 3/4	43 1/8	8 3/8	18	27 1/4	40	-
	RIGHT SIDE	38 3/4	39 1/2	40 1/4	43 1/8	8 3/8	18	27 1/4	40	-
	FRONT	34 1/8	34 7/8	35 5/8	43 1/8	6 7/8	16 1/2	25 3/4	38 1/2	-
CHS240	LEFT SIDE	32 7/8	33 5/8	34 3/8	43 1/8	4 1/4	13 1/4	22 1/4	31 1/4	40 1/4
	BACK	47 3/4	48 1/2	49 1/4	43 1/8	4 1/4	13 1/4	22 1/4	31 1/4	40 1/4
	RIGHT SIDE	61 1/8	61 7/8	62 5/8	43 1/8	3 3/4	12 3/4	21 3/4	30 3/4	39 3/4
	FRONT	20 1/8	20 7/8	21 5/8	43 1/8	3 3/4	12 3/4	21 3/4	30 3/4	39 3/4

DIMENSIONS - MM										
UNIT	BAFFLE	A	B	C	D	E	F	G	H	J
CHS180	LEFT SIDE	501	520	539	1095	212	457	694	1015	-
	BACK	2037	2056	2075	1095	212	457	694	1015	-
	RIGHT SIDE	983	1002	1021	1095	212	457	694	1015	-
	FRONT	866	885	904	1095	174	419	656	977	-
CHS240	LEFT SIDE	834	853	872	1095	108	337	565	794	1022
	BACK	1214	1233	1252	1095	108	337	565	794	1022
	RIGHT SIDE	1551	1570	1589	1095	95	324	552	781	1010
	FRONT	510	530	549	1095	95	324	552	781	1010

FIGURE 37 - Wind Baffle Fabrication



FOR 15 TON A/C AND HP
BACK SIDE ONLY

FIGURE 38 - 15 Ton Wind Baffle Brackets - Fabrication

15 TON WIND BAFFLE BRACKET - TOP
QTY: 2 NOS

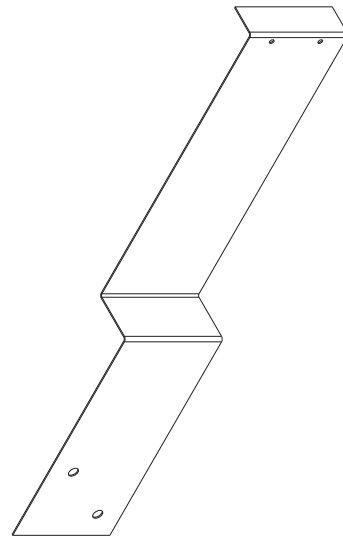
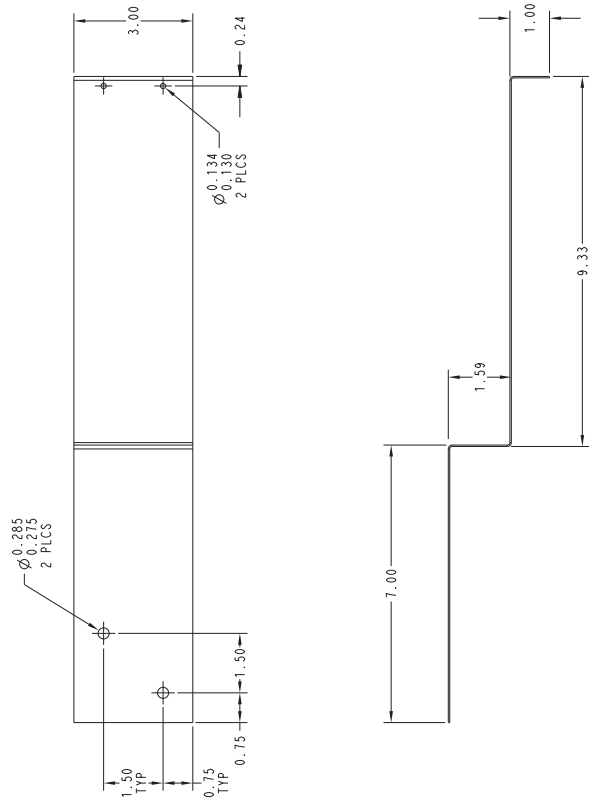

15 TON WIND BAFFLE BRACKET - BOTTOM
QTY: 1 NO

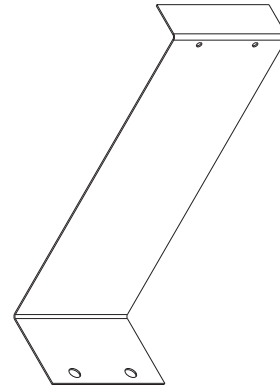
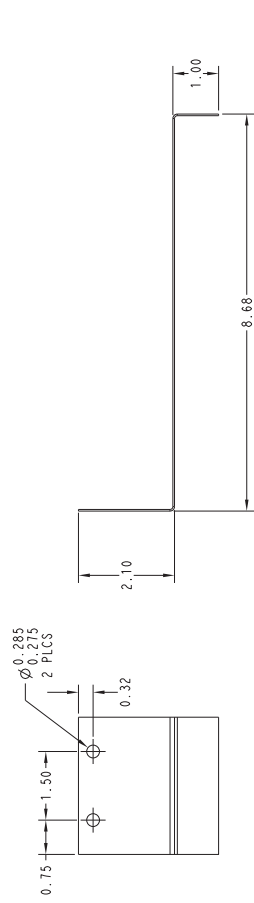

FIGURE 39 - 15 Ton Wind Baffle Brackets - Installation

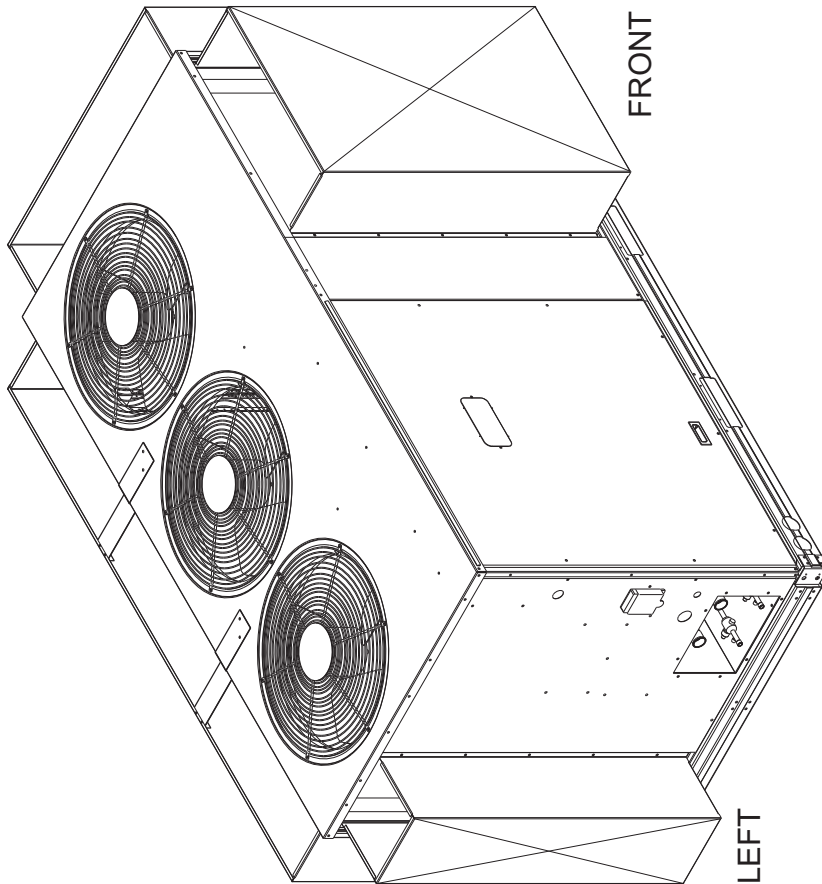
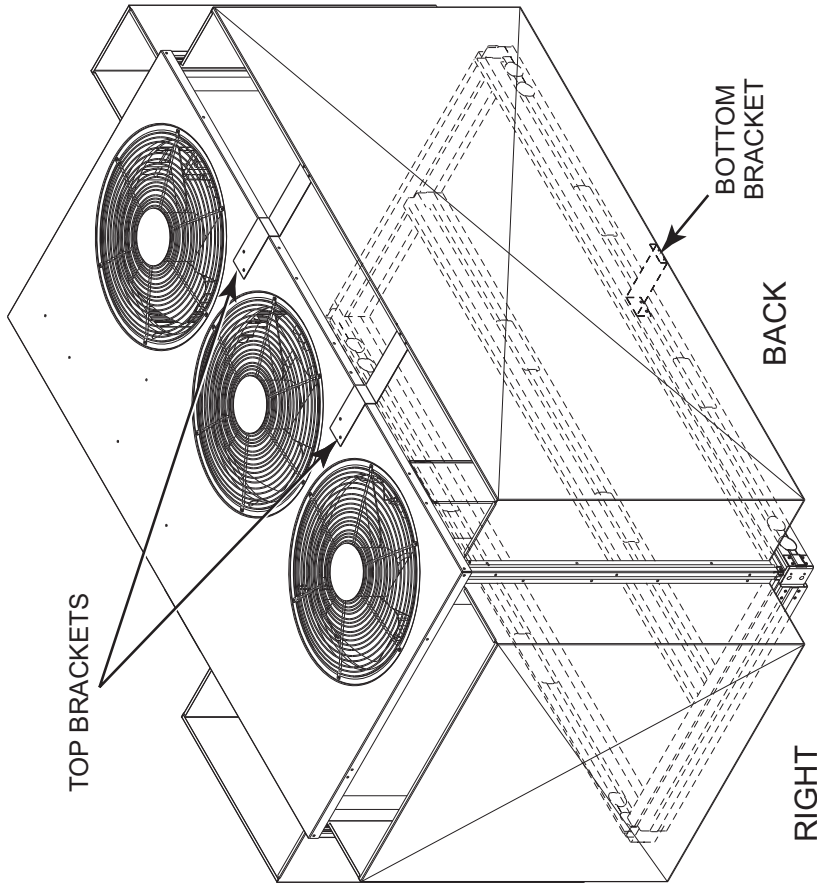
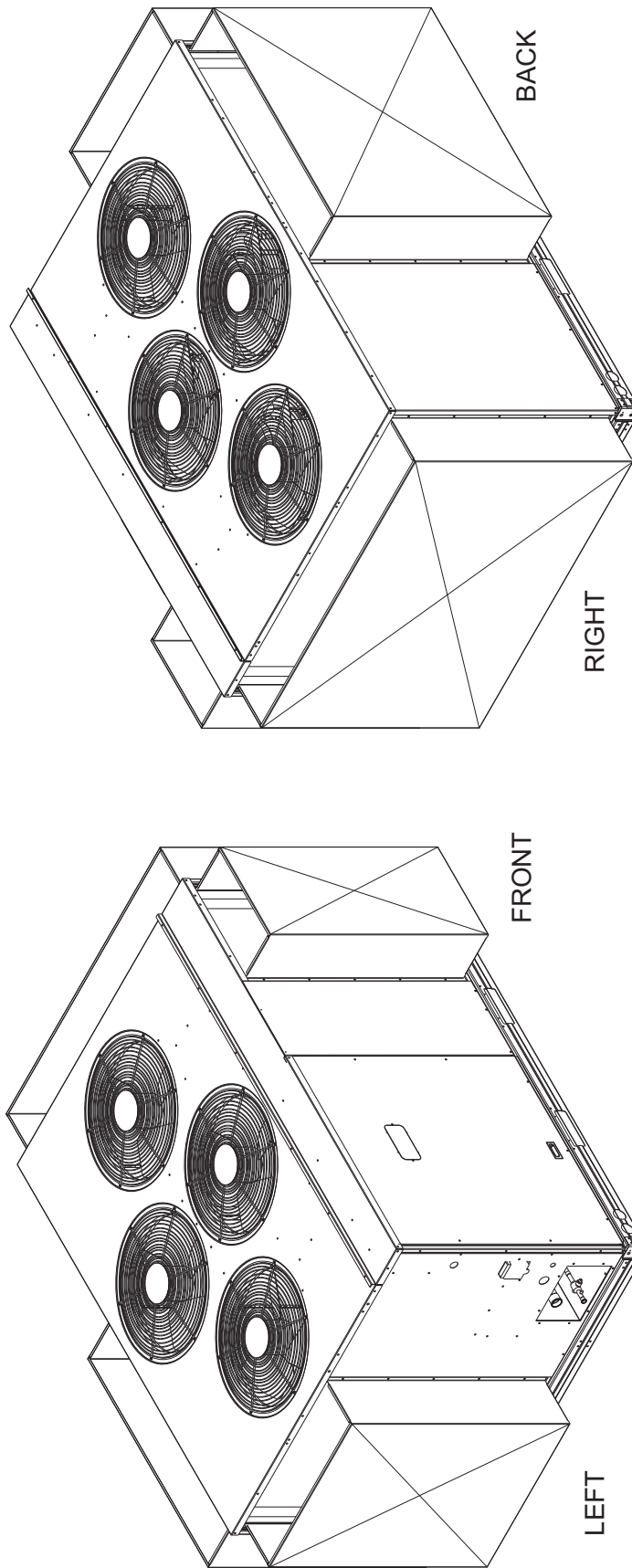

FIGURE 40 - 20 Ton Wind Baffle Brackets - Installation



START UP CHECKLIST

I. PRELIMINARY INFORMATION

OUTDOOR: MODEL NO. _____ SERIAL NO. _____

INDOOR: AIR HANDLER MANUFACTURER _____

MODEL NO. _____ SERIAL NO. _____

ADDITIONAL ACCESSORIES _____

II. PRE-START-UP

OUTDOOR UNIT

IS THERE ANY SHIPPING DAMAGE? (Y/N) _____

IF SO, WHERE: _____

WILL THIS DAMAGE PREVENT UNIT START-UP? (Y/N) _____

CHECK POWER SUPPLY. DOES IT AGREE WITH UNIT? (Y/N) _____

HAS THE GROUND WIRE BEEN CONNECTED? (Y/N) _____

HAS THE CIRCUIT PROTECTION BEEN SIZED AND INSTALLED PROPERLY? (Y/N) _____

ARE THE POWER WIRES TO THE UNIT SIZED AND INSTALLED PROPERLY? (Y/N) _____

CONTROLS

ARE THERMOSTAT AND INDOOR FAN CONTROL WIRING CONNECTIONS MADE AND CHECKED?
(Y/N) _____

ARE ALL WIRING TERMINALS (including main power supply) TIGHT? (Y/N) _____

HAS CRANKCASE HEATER BEEN ENERGIZED FOR 24 HOURS? (Y/N) _____

INDOOR UNIT

HAS WATER BEEN PLACED IN DRAIN PAN TO CONFIRM PROPER DRAINAGE? (Y/N) _____

ARE PROPER AIR FILTERS IN PLACE? (Y/N) _____

HAVE FAN AND MOTOR PULLEYS BEEN CHECKED FOR PROPER ALIGNMENT? (Y/N) _____

DO THE FAN BELTS HAVE PROPER TENSION? (Y/N) _____

HAS CORRECT FAN ROTATION BEEN CONFIRMED? (Y/N) _____

PIPING

ARE LIQUID LINE SOLENOID VALVES LOCATED AT THE INDOOR COILS AS REQUIRED? (Y/N) _____

HAVE LEAK CHECKS BEEN MADE AT COMPRESSOR, OUTDOOR AND INDOOR COILS,
TXVs (Thermostatic Expansion Valves), SOLENOID VALVES, FILTER DRIERS, AND FUSIBLE PLUGS
WITH A LEAK DETECTOR? (Y/N) _____

LOCATE, REPAIR, AND REPORT ANY LEAKS. _____

HAVE LIQUID LINE SERVICE VALVES BEEN OPENED? (Y/N) _____

HAVE SUCTION SERVICE VALVES BEEN OPENED? (Y/N) _____

