

Installation Instructions

RHS Series - 1 & 3 Phase 3 to 6 Ton With R-410A Refrigerant



PACKAGED HEAT PUMP UNITS

International Comfort Products, LLC
Lewisburg, TN. 37091

NOTE: Read the entire instruction manual before starting the installation.

TABLE OF CONTENTS

SAFETY CONSIDERATIONS	1
INSTALLATION	3
Step 1 - Plan for Unit Location	3
Step 2 - Plan for Sequence of Unit Installation	4
Step 3 - Inspect Unit	4
Step 4 - Provide Unit Support	4
Step 5 - Field Fabricate Ductwork	6
Step 6 - Rig and Place Unit	6
Step 7 - Convert to Horizontal & Connect Ductwork	7
Step 8 - Install Outside Air Hood	7
Step 9 - Install External Condensate Trap and Line	9
Step 10 - Make Electrical Connections	9
Step 11 - Adjust Factory-Installed Options	20
Step 12 - Install Accessories	20

SAFETY CONSIDERATIONS

Improper installation, adjustment, alteration, service, maintenance, or use can cause explosion, fire, electrical shock or other conditions which may cause personal injury or property damage. Consult a qualified installer, service agency, or your distributor or branch for information or assistance. The qualified installer or agency must use factory-authorized kits or accessories when modifying this product. Refer to the individual instructions packaged with the kits or accessories when installing.

Follow all safety codes. Wear safety glasses and work gloves. Use quenching cloths for brazing operations and have a fire extinguisher available. Read these instructions thoroughly and follow all warnings or cautions attached to the unit. Consult local building codes and appropriate national electrical codes (in USA, ANSI/NFPA70, National Electrical Code (NEC); in Canada, CSA C22.1) for special requirements.

It is important to recognize safety information. This is the safety-alert symbol . When you see this symbol on the unit and in instructions or manuals, be alert to the potential for personal injury.

Understand the signal words DANGER, WARNING, CAUTION, and NOTE. These words are used with the safety-alert symbol. DANGER identifies the most serious hazards which **will** result in severe personal injury or death. WARNING signifies hazards which **could** result in personal injury or death. CAUTION is used to identify unsafe practices, which **may** result in minor personal injury or product and property damage. NOTE is used to highlight suggestions which **will** result in enhanced installation, reliability, or operation.

WARNING

ELECTRICAL SHOCK HAZARD

Failure to follow this warning could cause personal injury or death.

Before performing service or maintenance operations on unit, always turn off main power switch to unit and install lockout tag. Unit may have more than one power switch.

WARNING

UNIT OPERATION AND SAFETY HAZARD

Failure to follow this warning could cause personal injury, death and/or equipment damage.

R-410A refrigerant systems operate at higher pressures than standard R-22 systems. Do not use R-22 service equipment or components on R-410A refrigerant equipment.

WARNING

PERSONAL INJURY AND ENVIRONMENTAL HAZARD

Failure to follow this warning could cause personal injury or death.

Relieve pressure and recover all refrigerant before system repair or final unit disposal.

Wear safety glasses and gloves when handling refrigerants. Keep torches and other ignition sources away from refrigerants and oils.

CAUTION

CUT HAZARD



Failure to follow this caution may result in personal injury.

Sheet metal parts may have sharp edges or burrs. Use care and wear appropriate protective clothing, safety glasses and gloves when handling parts and servicing heat pump units.

FIGURE 1

Base Unit Dimensions: RHS036-72

NOTES:

1. DIMENSIONS ARE IN INCHES. DIMENSIONS IN [] ARE IN MILLIMETERS.
2.  CENTER OF GRAVITY
3.  DIRECTION OF AIR FLOW

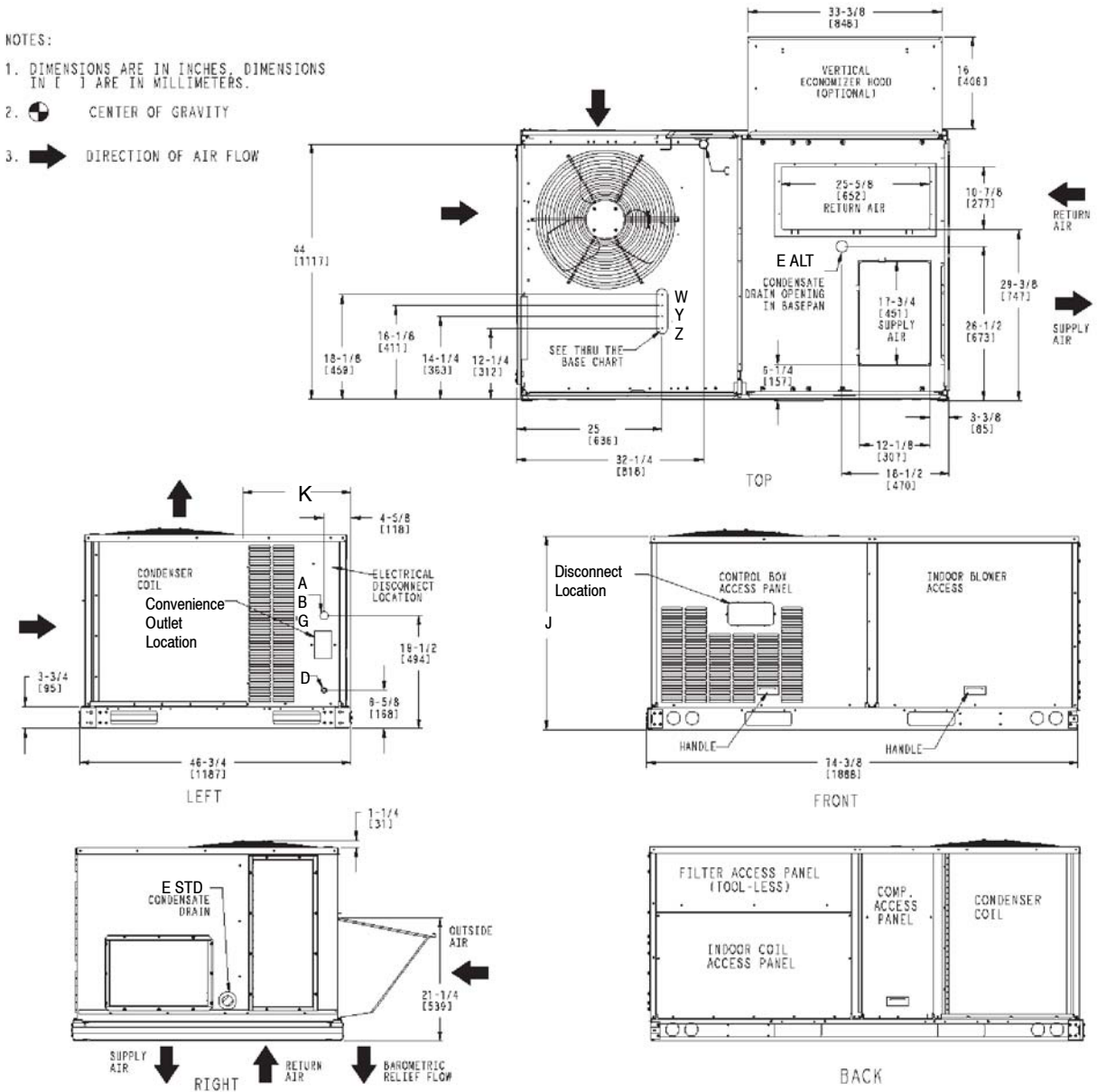

Vertical Connections / Economizer

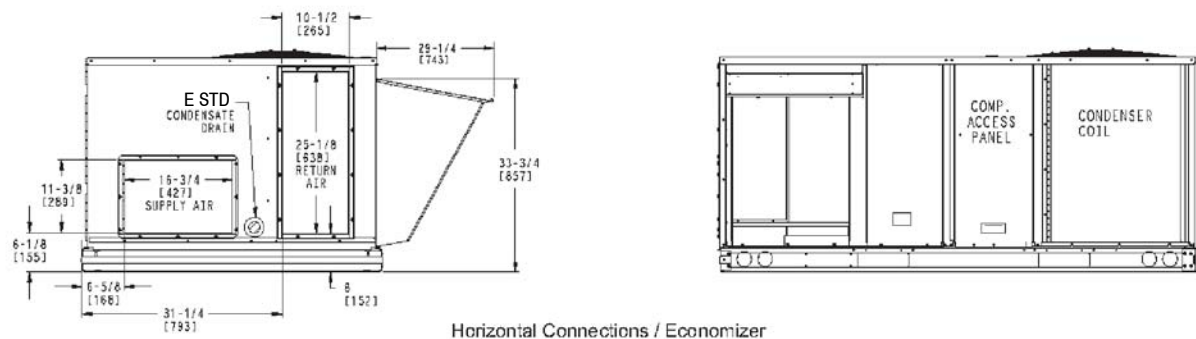

Horizontal Connections / Economizer

		Thru the Base Chart, Holes Required For Use With CRBTMPWR001A01			Unit RHS	J	K
Connection Sizes (DIA)		Threaded Conduit Size	Wire Use	Required Hole Sizes (Max.)			
A	1-3/8" [35] Field Power Supply Hole	W	1/2"	ACC	036	33-3/8 [847]	18-5/8 [472]
B	2" [51] Power Supply Knockout	X	1/2"	24V	048	33-3/8 [847]	14-7/8 [377]
C	1-3/4" [44] Gauge Access Plug	Y*	3/4" (001)	Power	060	41-3/8 [1051]	14-7/8 [377]
D	7/8" [22] Field Control Wiring Hole	*	Select either 3/4" or 1/2" for Power, Depending on Wire Wize		072	41-3/8 [1051]	14-7/8 [377]
E	3/4"-14 NPT Condensate Drain						
G	2-1/2" [64] Power Supply Knock-out						

Figure 1A

Unit Weights and Center of Gravity RHS036-72

UNIT	STD. UNIT WEIGHT		CORNER WEIGHT (A)		CORNER WEIGHT (B)		CORNER WEIGHT (C)		CORNER WEIGHT (D)		Center of Gravity		HEIGHT
	LBS.	KG.	LBS.	KG.	LBS.	KG.	LBS.	KG.	LBS.	KG.	X	Y	Z
RHS036	505	229	136	62	130	59	117	53	123	56	36 1/4 [921]	22 1/8 [562]	16 3/8 [416]
RHS048	510	231	138	63	131	59	118	54	124	56	36 1/4 [921]	22 1/8 [562]	16 1/2 [419]
RHS060	590	268	159	72	146	66	137	62	149	68	35 5/8 [905]	22 5/8 [575]	20 1/8 [511]
RHS072	630	286	166	75	166	75	149	68	149	68	37 1/4 [946]	22 1/8 [562]	20 3/4 [527]

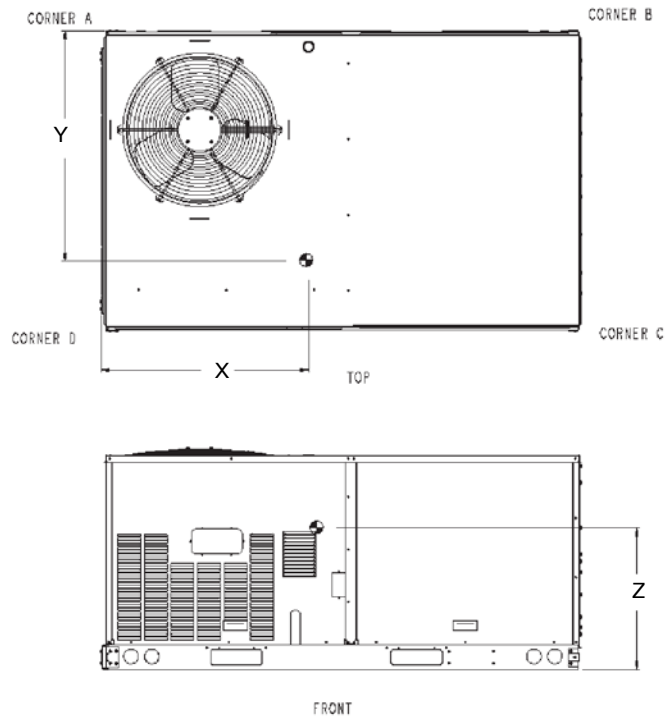

INSTALLATION

Jobsite Survey

Complete the following checks before installation.

1. Consult local building codes and the NEC (National Electrical Code) ANSI/NFPA 70 for special installation requirements.
2. Determine unit location (from project plans) or select unit location.
3. Check for possible overhead obstructions which may interfere with unit lifting or rigging.

Step 1 — Plan for Unit Location

Select a location for the unit and its support system (curb or other) that provides for the minimum clearances required for safety. This includes the clearance to combustible surfaces, unit performance and service access below, around and above unit as specified in unit drawings. See Fig. 2.

NOTE: Consider also the effect of adjacent units.

Unit may be installed directly on wood flooring or on Class A, B, or C roof-covering material when roof curb is used.

Do not install unit in an indoor location. Do not locate air inlets near exhaust vents or other sources of contaminated air.

Figure 2 Service Clearance Dimensional Drawing

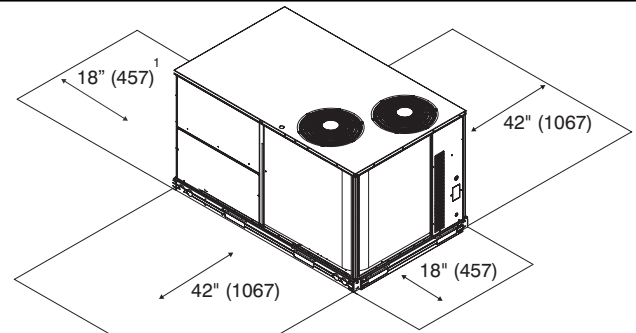

¹ Required bottom condensate drain connection. Otherwise, 36" (914mm) for condensate connection.

Although unit is weatherproof, avoid locations that permit water from higher level runoff and overhangs to fall onto the unit.

Select a unit mounting system that provides adequate height to allow for removal and disposal of frost and ice that will form during the heating-defrost mode as well as allow installation of condensate trap per requirements. Refer to Step 9 — Install External Condensate Trap and Line — for required trap dimensions.

Roof mount

Check building codes for weight distribution requirements. Unit operating weight is shown in Table 1.

Step 2 — Plan for Sequence of Unit Installation

The support method used for this unit will dictate different sequences for the steps of unit installation. For example, on curb-mounted units, some accessories must be installed on the unit before the unit is placed on the curb. Review the following for recommended sequences for installation steps.

Curb-mounted installation

- Install curb
- Install field-fabricated ductwork inside curb
- Install accessory thru-base service connection package (affects curb and unit) (refer to accessory installation instructions for details)
- Prepare bottom condensate drain connection to suit planned condensate line routing (refer to Step 9 for details)
- Rig and place unit
- Install outdoor air hood
- Install condensate line trap and piping
- Make electrical connections
- Install other accessories

Pad-mounted installation

- Prepare pad and unit supports
- Check and tighten the bottom condensate drain connection plug
- Rig and place unit
- Convert unit to side duct connection arrangement
- Install field-fabricated ductwork at unit duct openings
- Install outdoor air hood
- Install condensate line trap and piping
- Make electrical connections
- Install other accessories

Frame-mounted installation

Frame-mounted applications generally follow the sequence for a curb installation. Adapt as required to suit specific installation plan.

Step 3 — Inspect unit

Inspect unit for transportation damage. File any claim with transportation agency.

Confirm before installation of unit that voltage, amperage and circuit protection requirements listed on unit data plate agree with power supply provided.

Step 4 — Provide Unit Support

Roof Curb Mount

Accessory roof curb details and dimensions are shown in Fig. 3. Assemble and install accessory roof curb in accordance with instructions shipped with the curb.

NOTE: The gasketing of the unit to the roof curb is critical for a watertight seal. Install gasket supplied with the roof curb as shown in Fig. 3. Improperly applied gasket can also result in air leaks and poor unit performance.

Curb should be level. This is necessary for unit drain to function properly. Unit leveling tolerances are shown in Fig. 4. Refer to Accessory Roof Curb Installation Instructions for additional information as required.

Install insulation, cant strips, roofing felt, and counter flashing as shown. *Ductwork must be attached to curb and not to the unit. The accessory thru-the-base power package must be installed before the unit is set on the roof curb.*

If electric and control wiring is to be routed through the basepan, attach the accessory thru-the-base service connections to the basepan in accordance with the accessory installation instructions.

Slab Mount (Horizontal Units Only)

Provide a level concrete slab that extends a minimum of 6 in. (150 mm) beyond unit cabinet. Install a gravel apron in front of condenser coil air inlet to prevent grass and foliage from obstructing airflow.

NOTE: Horizontal units may be installed on a roof curb if required.

Alternate Unit Support (In Lieu of Curb or Slab Mount)

A non-combustible sleeper rail can be used in the unit curb support area. If sleeper rails cannot be used, support the long sides of the unit with a minimum of 3 equally spaced 4-in. x 4-in. (102 mm x 102 mm) pads on each side.

Table 1 – Operating Weights

RHS	UNITS LB (KG)			
	036	048	060	072
Base Unit	505 (229)	510 (231)	590 (268)	630 (286)
Economizer				
Vertical	80 (36)	80 (36)	80 (36)	80 (36)
Horizontal	105 (48)	105 (48)	105 (48)	105 (48)
Curb				
14-in/356 mm	110 (50)	110 (50)	110 (50)	110 (50)
24-in/610 mm	145 (66)	145 (66)	145 (66)	145 (66)

Figure 3

Roof Curb Details RHS036-72

Roof Curb Accessory	A	Unit Size
CRRFCURB001A01	1' 2" [356]	RHS036-072
CRRFCURB002A01	2' 0" [610]	

NOTES:

1. Roofcurb accessory is shipped disassembled.
2. Insulated panels, 1" thick polyurethane foam, 1-3/4# density.
3. Dimensions in. [] in millimeters.
4. Roofcurb 18 ga steel on 14" curb, 16 ga steel in 24" curb.
5. Attach ductwork to curb (Flanges of duct rest on curb)
6. Service clearance 4' on each side.
7.  Direction of airflow.
8. Connector pkg. CRBTMPWR001A01 and CRBTMPWR002A01 are for thru-the-curb connections. Pkg. CRBTMPWR003A01 and CRBTMPWR004A01 are for thru-the-bottom connections.

Connector Pkg. Acc.	B	C	D Alt. Drain Hole	Power	Control	Accessory Power
CRBTMPWR001A01	2'-8 7/16" [827]	1' 10" [583]	1-3/4" [44.5]	3/4" [19] NPT	1/2" [12.7] NPT	1/2" [12.7] NPT
CRBTMPWR002A01				1-1/4" [31.7] NPT		
CRBTMPWR003A01				3/4" [19.0] NPT		
CRBTMPWR004A01				1-1/4" [31.7] NPT		

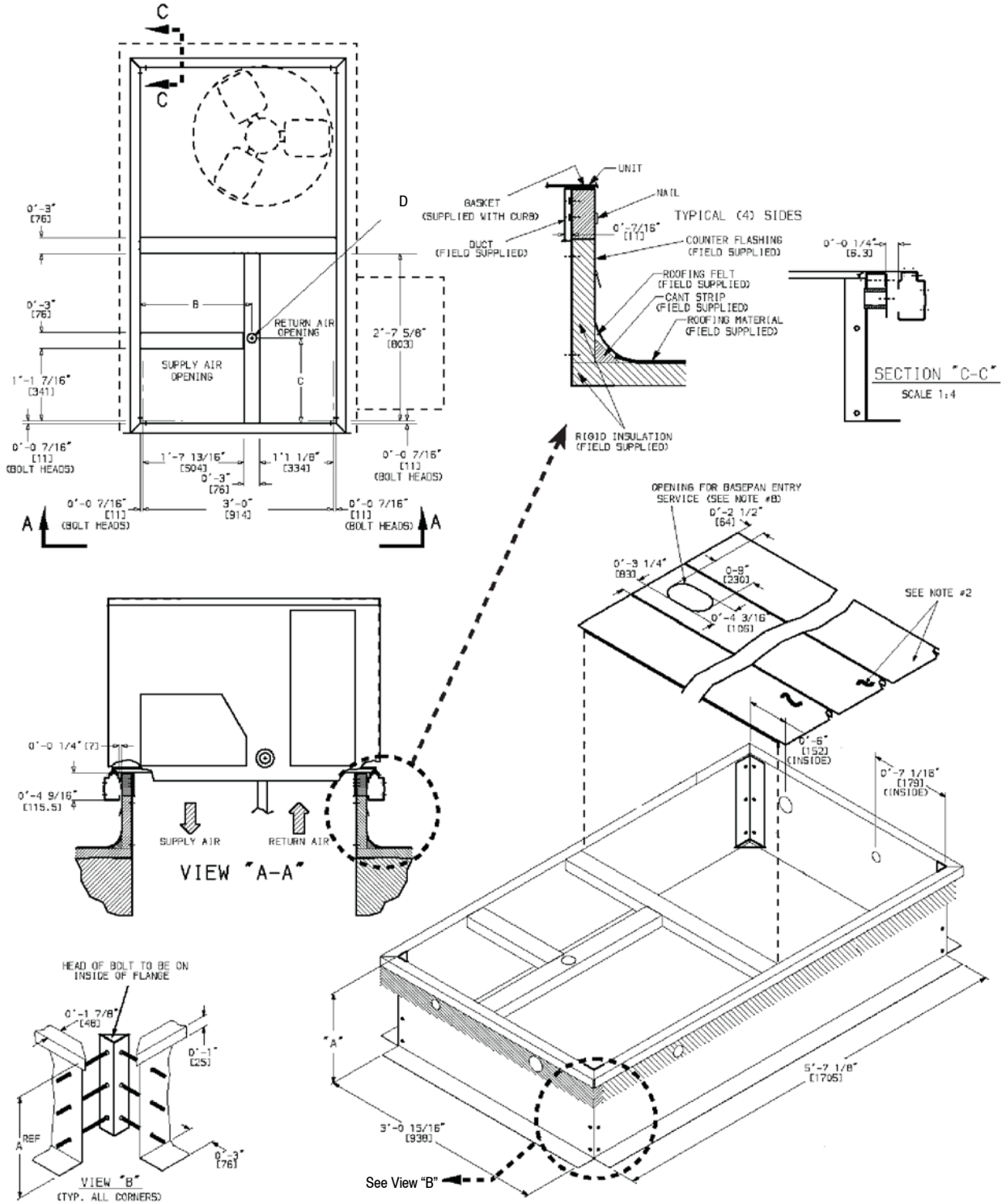

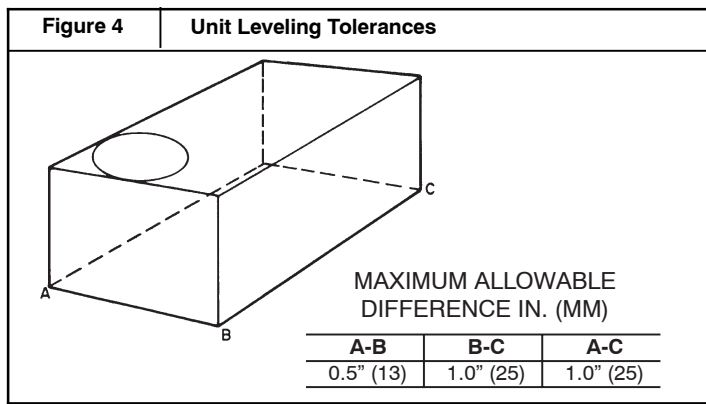

Step 5 — Field Fabricate Ductwork

Cabinet return-air static pressure (a negative condition) shall not exceed 0.35 in. wg (87 Pa) with economizer or 0.45 in. wg (112 Pa) without economizer.

For vertical ducted applications, secure all ducts to roof curb and building structure. *Do not connect ductwork to unit.*

Insulate and weatherproof all external ductwork, joints, and roof openings with counter flashing and mastic in accordance with applicable codes.

Ducts passing through unconditioned spaces must be insulated and covered with a vapor barrier.

If a plenum return is used on a vertical unit, the return should be ducted through the roof deck to comply with applicable fire codes.

For units with accessory electric heaters: Horizontal applications require a minimum clearance to combustible surfaces of 1-in (25

mm) from duct for first 12-in (305 mm) away from unit. Vertical applications do not require a minimum clearance.

Minimum clearance not required around ductwork.

Step 6 — Rig and Place Unit

Keep unit upright and do not drop. Spreader bars are not required if top crating is left on unit. Rollers may be used to move unit across a roof. Level by using unit frame as a reference. See Table 1 and Fig. 5 for additional information.

Lifting holes are provided in base rails as shown in Fig. 5. Refer to rigging instructions on unit.

⚠ CAUTION

UNIT DAMAGE HAZARD

Failure to follow this caution may result in equipment damage.

All panels must be in place when rigging. Unit is not designed for handling by fork truck.

Before setting the unit onto the curb, recheck gasketing on curb.

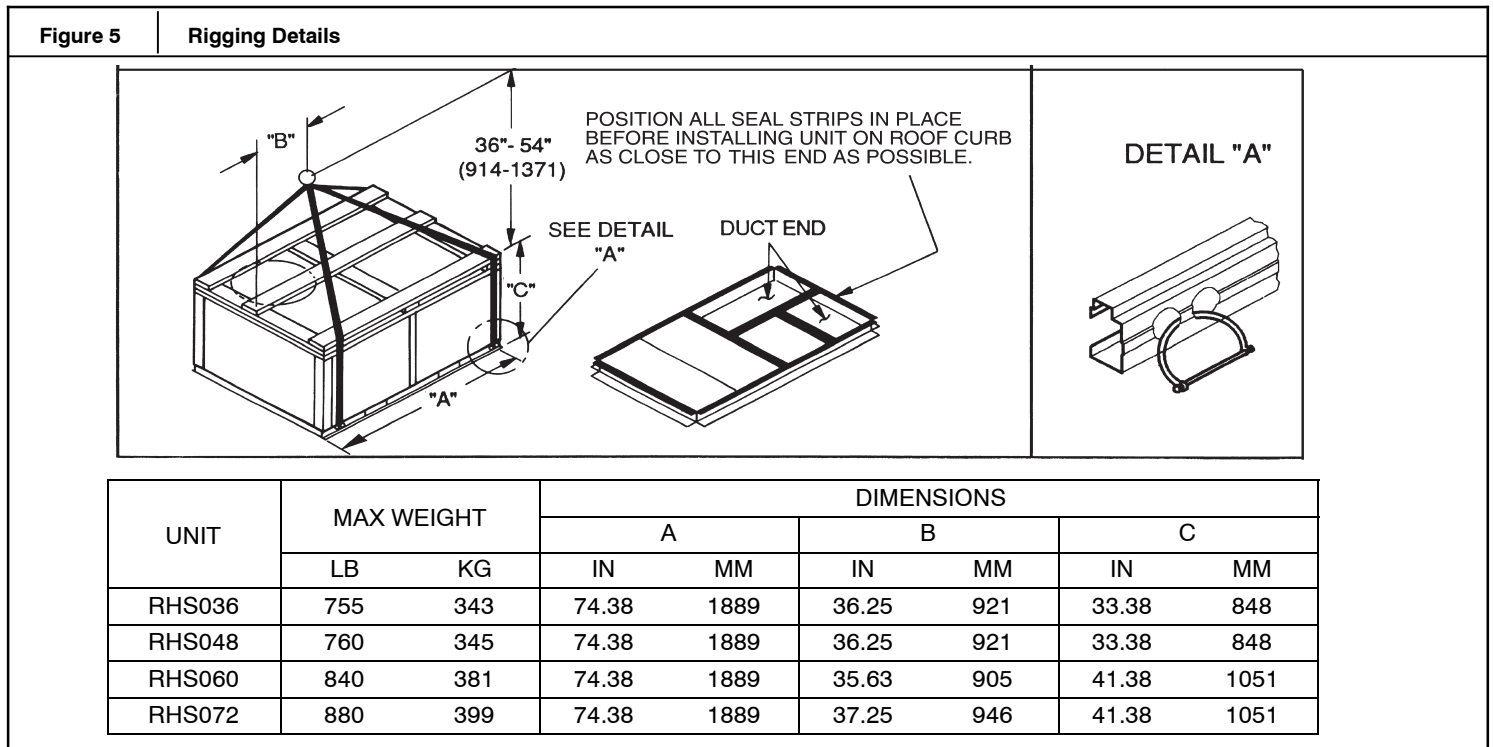

NOTES:

- Dimensions in () are in millimeters.
- Hook rigging shackles through holes in base rail, as shown in detail "A." Holes in base rails are centered around the unit center of gravity. Use wooden top to prevent rigging straps from damaging unit.

Positioning on Curb

Position unit on roof curb so that the following clearances are maintained: $\frac{1}{4}$ in. (6.4 mm) clearance between the roof curb and the base rail inside the front and rear, 0.0 in. clearance between the roof curb and the base rail inside on the duct end of the unit. This will result in the distance between the roof curb and the base rail inside on the condenser end of the unit being approximately equal to Fig. 3, section C-C.

Although unit is weatherproof, guard against water from higher level runoff and overhangs.

After unit is in position, remove the compressor access panel. Holding the blocking between compressors with one hand, cut the strapping. Carefully remove the blocking without damaging tubing, wiring, or controls. Remove the strapping and replace the access panel.

Remove all shipping materials and top skid. Recycle or dispose of all shipping materials.

Step 7 — Convert to Horizontal and Connect Ductwork (when required)

Unit is shipped in the vertical duct configuration. Unit *without* factory-installed economizer or return air smoke detector option may be field-converted to horizontal ducted configuration. To convert to horizontal configuration, remove screws from side duct opening covers and remove covers. Using the same screws, install covers on vertical duct openings with the insulation-side down. Seals around duct openings must be tight. See Fig. 6.

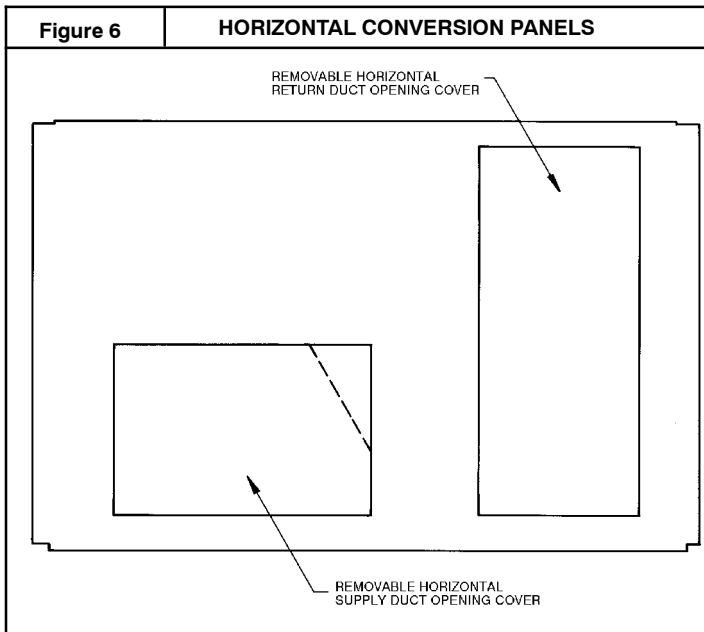

Field-supplied flanges should be attached to horizontal duct openings and all ductwork should be secured to the flanges. Insulate and weatherproof all external ductwork, joints, and roof or building openings with counter flashing and mastic in accordance with applicable codes.

Do not cover or obscure visibility to the unit's informative data plate when insulating horizontal ductwork.

Step 8 — Install Outside Air Hood

Economizer Hood Removal and Setup - Factory Option

1. The hood is shipped in knock-down form and located in the return air compartment. It is attached to the economizer using two plastic tie-wraps.

2. To gain access to the hood, remove the filter access panel. (See Fig. 7.)

3. Locate and cut the (2) plastic tie-wraps, being careful to not damage any wiring. (See Fig. 8.)

4. Carefully lift the hood assembly through the filter access opening and assemble per the steps outlined in *Economizer Hood and Two-Position Hood* on following page.

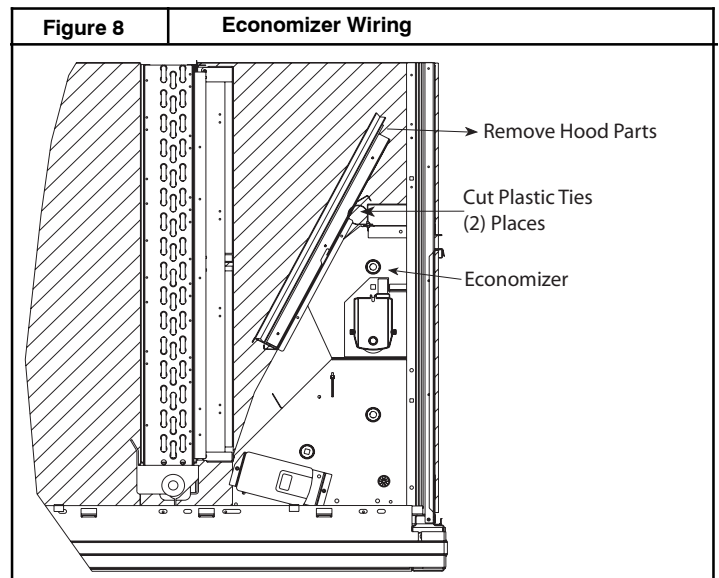
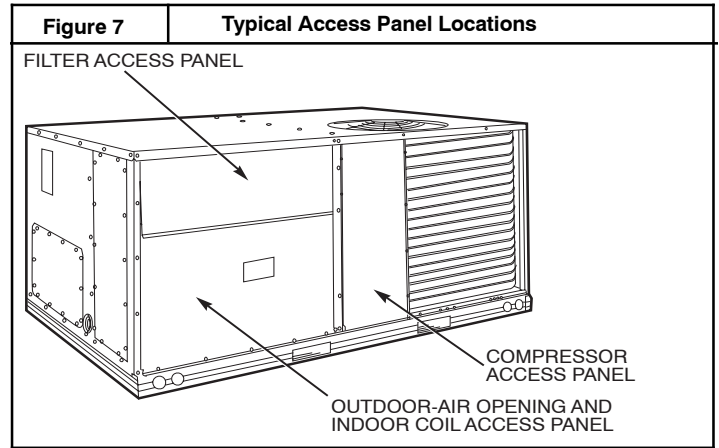

Two Position Damper Hood Removal and Setup - Factory Option

1. The hood is shipped in knock-down form and assembled to a metal support tray using plastic stretch wrap. Located in the return air compartment, the assembly's metal tray is attached to the basepan and also attached to the damper using two plastic tie-wraps.

2. To gain access to the hood, remove the filter access panel. (See Fig. 7.)

3. Locate the (2) screws holding the metal tray to the basepan and remove. Locate and cut the (2) plastic tie-wraps securing the assembly to the damper. (See Fig. 9.) Be careful to not damage any wiring or cut tie-wraps securing any wiring.

4. Carefully lift the hood assembly (with metal tray) through the filter access opening and assemble per the steps outlined in *Economizer Hood and Two-Position Hood* on following page.

Figure 9

Damper Assembly

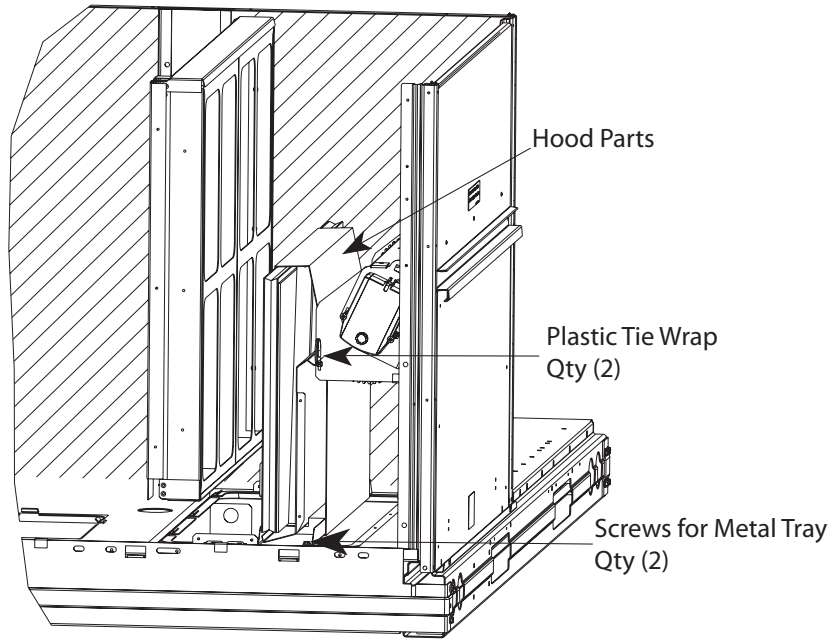

Economizer Hood and Two-Position Hood

NOTE: If the power exhaust accessory is to be installed on the unit, the hood shipped with the unit will not be used and must be discarded. Save the aluminum filter for use in the power exhaust hood assembly.

1. The indoor coil access panel will be used as the top of the hood. Remove the screws along the sides and bottom of the indoor coil access panel. See Fig. 10.

Figure 10

Indoor Coil Access Panel Relocation

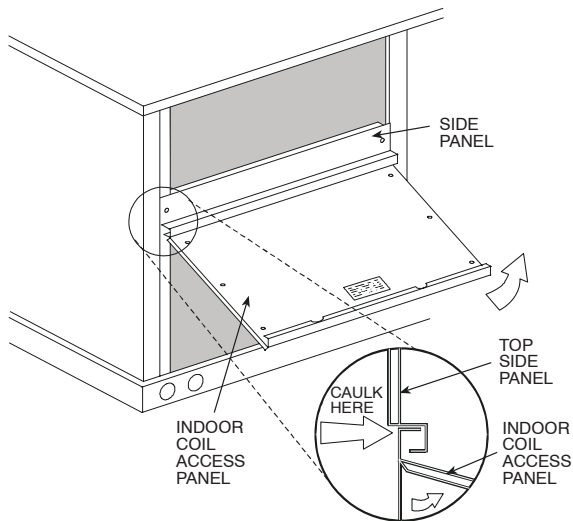

2. Swing out indoor coil access panel and insert the hood sides under the panel (hood top). Use the screws provided to attach the hood sides to the hood top. Use screws provided to attach the hood sides to the unit. See Fig. 11.

Figure 11

Economizer Hood Construction

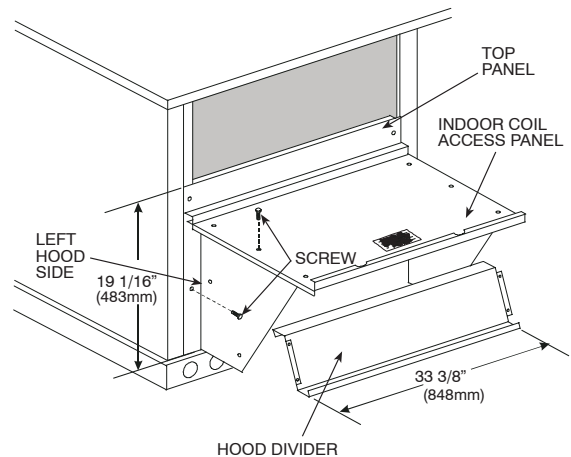

3. Remove the shipping tape holding the economizer barometric relief damper in place.
4. Insert the hood divider between the hood sides. See Fig. 11 and 12. Secure hood divider with 2 screws on each hood side. The hood divider is also used as the bottom filter rack for the aluminum filter.
5. Open the filter clips which are located underneath the hood top. Insert the aluminum filter into the bottom filter rack (hood divider). Push the filter into position past the open filter clips. Close the filter clips to lock the filter into place. See Fig. 12.

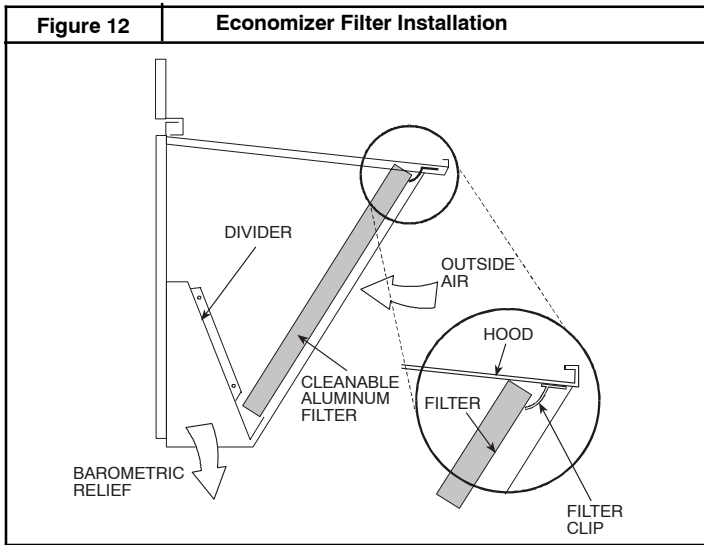

6. Caulk the ends of the joint between the unit top panel and the hood top.
7. Replace the filter access panel.

Step 9 — Install External Condensate Trap and Line

The unit has one $\frac{3}{4}$ -in. condensate drain connection on the end of the condensate pan and an alternate connection on the bottom. See Fig. 13. Unit airflow configuration does not determine which drain connection to use. Either drain connection can be used with vertical or horizontal applications.

When using the standard side drain connection, ensure the red plug in the alternate bottom connection is tight. Do this before setting the unit in place. The red drain pan can be tightened with a $\frac{1}{2}$ -in. square socket drive extension.

To use the alternate bottom drain connection, remove the red drain plug from the bottom connection (use a $\frac{1}{2}$ -in. square socket drive extension) and install it in the side drain connection.

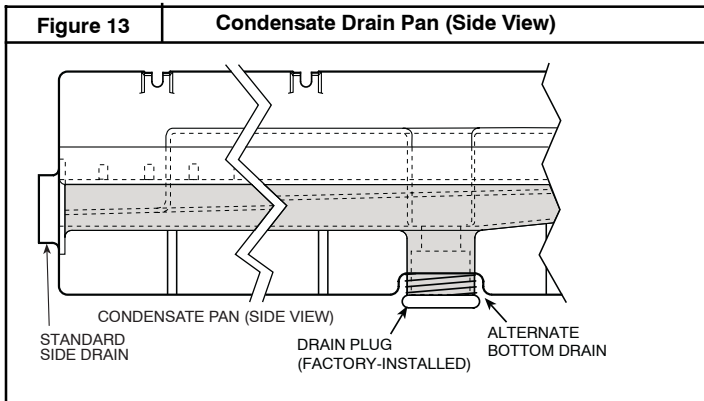

The piping for the condensate drain and external trap can be completed after the unit is in place. See Fig. 14.

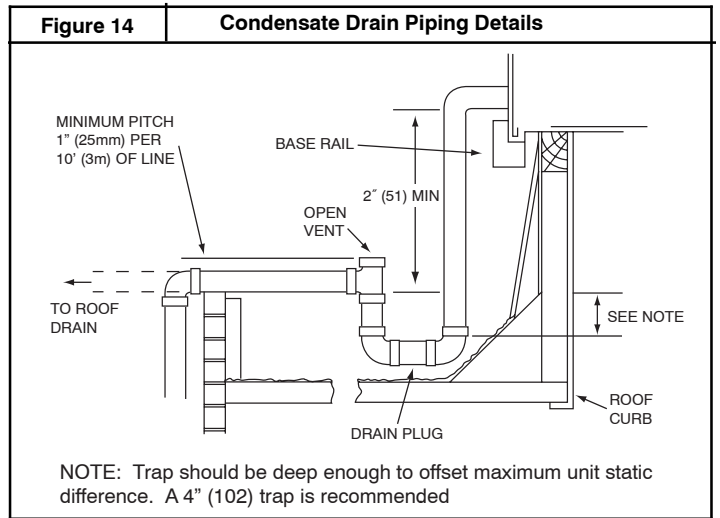

All units must have an external trap for condensate drainage. Install a trap at least 4-in. (102 mm) deep and protect against freeze-up. If drain line is installed downstream from the external trap, pitch the line away from the unit at 1-in. per 10 ft (25 mm in 3 m) of run. Do not use a pipe size smaller than the unit connection ($\frac{3}{4}$ -in.).

Step 10 — Make Electrical Connections

⚠ WARNING

ELECTRICAL SHOCK HAZARD

Failure to follow this warning could result in personal injury or death.

Do not use gas piping as an electrical ground. Unit cabinet must have an uninterrupted, unbroken electrical ground to minimize the possibility of personal injury if an electrical fault should occur. This ground may consist of electrical wire connected to unit ground lug in control compartment, or conduit approved for electrical ground when installed in accordance with NEC (National Electrical Code); ANSI/NFPA 70, latest edition (in Canada, Canadian Electrical Code CSA [Canadian Standards Association] C22.1), and local electrical codes.

NOTE: Check all factory and field electrical connections for tightness. Field-supplied wiring shall conform with the limitations of 63°F (33°C) rise.

Field Power Supply

If equipped with optional Powered Convenience Outlet: The power source leads to the convenience outlet's transformer primary are not factory connected. Installer must connect these leads according to required operation of the convenience outlet. If an always-energized convenience outlet operation is desired, connect the source leads to the line side of the unit-mounted disconnect. (Check with local codes to ensure this method is acceptable in your area.) If a de-energize via unit disconnect switch operation of the convenience outlet is desired, connect the source leads to the load side of the unit disconnect. On a unit without a unit-mounted disconnect, connect the source leads to compressor contactor C and indoor fan contactor IFC pressure lugs with unit field power leads.

All units except 208/230-v units are factory wired for the voltage shown on the nameplate. *If the 208/230-v unit is to be connected to a 208-v power supply, the control transformer must be rewired by moving the black wire with the $\frac{1}{4}$ -in. female spade connector from the 230-v connection and moving it to the 208-v $\frac{1}{4}$ -in. male terminal on the primary side of the transformer. Refer to unit label*

diagram for additional information. Field power wires will be connected line-side pressure lugs on the power terminal block or at factory-installed option non-fused disconnect.

Field power wires are connected to the unit at line-side pressure lugs on compressor contactor C and indoor fan contactor IFC or terminal board (see wiring diagram label for control box component arrangement) or at factory-installed option non-fused disconnect switch. Max wire size is #2 AWG (copper only). (See Fig. 16)

NOTE: TEST LEADS - Unit may be equipped with short leads (pigtailed) on the field line connection points on contactor C or optional disconnect switch. These leads are for factory run-test purposes only; remove and discard before connecting field power wires to unit connection points. Make field power connections directly to line connection pressure lugs only.

⚠ WARNING

FIRE HAZARD
 Failure to follow this warning could result in intermittent operation or performance satisfaction.
 Do not connect aluminum wire between disconnect switch and furnace. Use only copper wire.
 (See Fig. 15.)

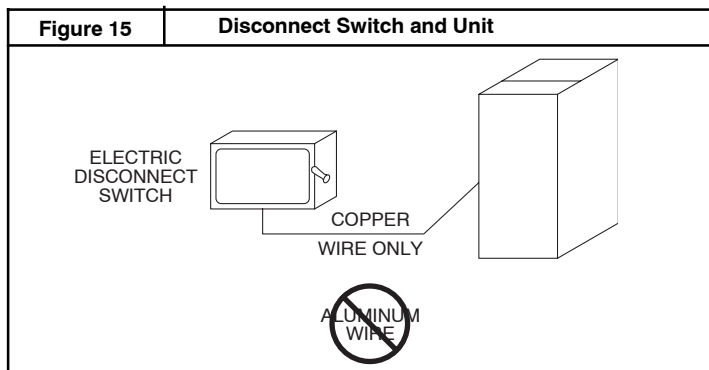

Units Without Factory-Installed Disconnect

When installing units, provide a disconnect switch per NEC (National Electrical Code) of adequate size. Disconnect sizing data is provided on the unit informative plate. Locate on unit cabinet or within sight of the unit per national or local codes. Do not cover unit informative plate if mounting the disconnect on the unit cabinet.

Units with Factory-Installed Disconnect (80 Amp Max.)

The factory-installed option disconnect switch is located in a weatherproof enclosure located under the main control box. The manual switch handle is accessible through an opening in the access panel. Discard the factory test leads (see Fig. 16).

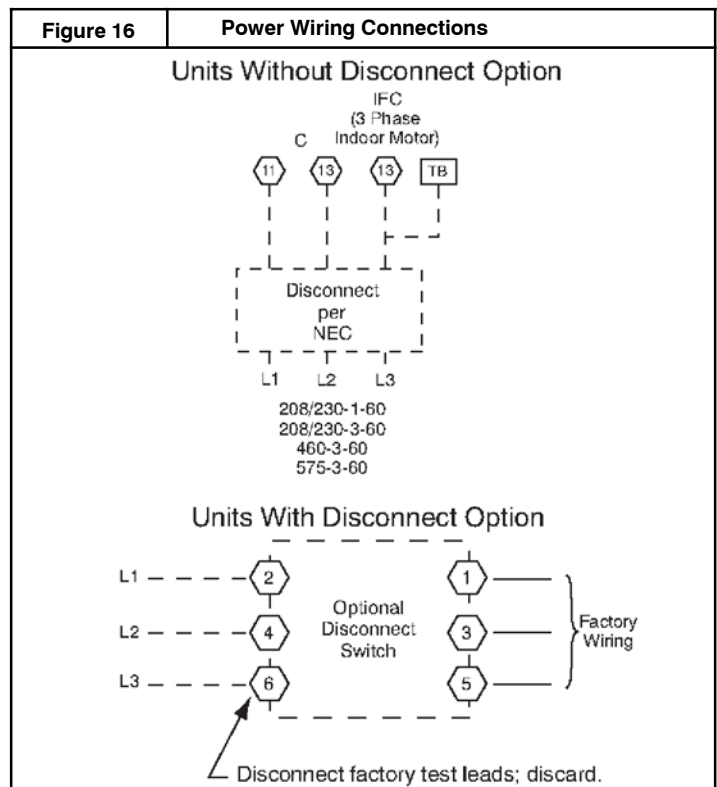

All units

All field wiring must comply with NEC and all local codes. Size wire based on MCA (Minimum Circuit Amps) on the unit informative plate. See Fig. 16 and the unit label diagram for power wiring connections to the unit power terminal blocks and equipment ground. Maximum wire size is #2 ga AWG per pole.

Provide a ground-fault and short-circuit over-current protection device (fuse or breaker) per NEC Article 440 (or local codes). Refer to unit informative data plate for MOCP (Maximum Over-current Protection) device size.

All field wiring must comply with the NEC and local requirements.

Convenience Outlets

⚠ WARNING

ELECTRICAL OPERATION HAZARD

Failure to follow this warning could result in personal injury or death.

Units with convenience outlet circuits may use multiple disconnects. Check convenience outlet for power status before opening unit for service. Locate its disconnect switch, if appropriate, and open it. Tag-out this switch, if necessary.

One type of factory installed convenience outlets is offered on RHS models: Non-powered which provide a 125-volt GFCI (ground-fault circuit-interrupter) duplex receptacle rated at 15-A behind a hinged waterproof access cover, located on the end panel of the unit. See Fig. 17.

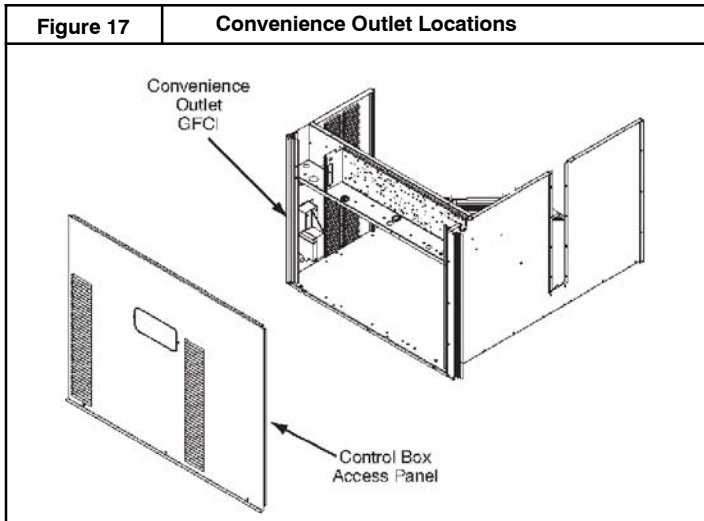

Installing Weatherproof Cover

A weatherproof while-in-use cover for the factory-installed convenience outlets is now required by UL standards. This cover cannot be factory-mounted due its depth; it must be installed at unit installation. For shipment, the convenience outlet is covered with a blank cover plate.

The weatherproof cover kit is shipped in the unit's control box. The kit includes the hinged cover, a backing plate and gasket.

DISCONNECT ALL POWER TO UNIT AND CONVENIENCE OUTLET.

Remove the blank cover plate at the convenience outlet; discard the blank cover.

Loosen the two screws at the GFCI duplex outlet, until approximately $\frac{1}{2}$ -in (13 mm) under screw heads are exposed. Press the gasket over the screw heads. Slip the backing plate over the screw heads at the keyhole slots and align with the gasket; tighten the two screws until snug (do not over-tighten).

Mount the weatherproof cover to the backing plate as shown in Fig. 18. Remove two slot fillers in the bottom of the cover to permit service tool cords to exit the cover. Check for full closing and latching.

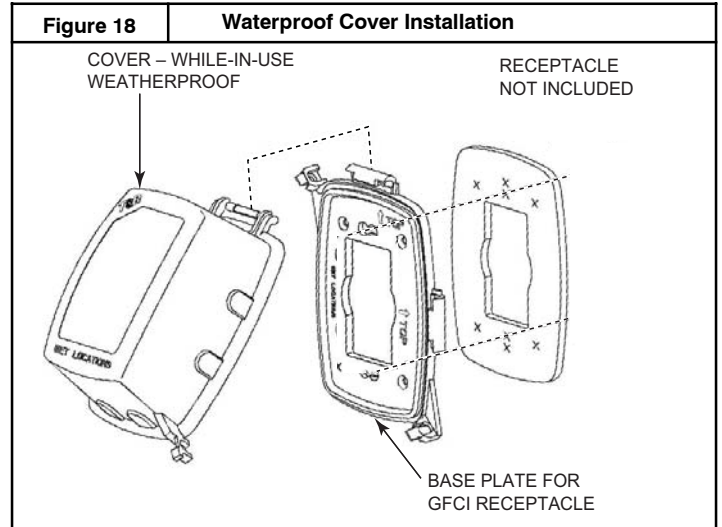

Non-powered Convenience Outlet: This type requires the field installation of a general-purpose 125-volt 15-A circuit powered from a source elsewhere in the building. Observe national and local codes when selecting wire size, fuse or breaker requirements and disconnect switch size and location. Route 125-v power supply conductors into the bottom of the utility box containing the duplex receptacle.

Test the GFCI receptacle by pressing the TEST button on the face of the receptacle to trip and open the receptacle. Check for proper grounding wires and power line phasing if the GFCI receptacle does not trip as required. Press the RESET button to clear the tripped condition.

Using unit-mounted convenience outlets: Units with unit-mounted convenience outlet circuits will often require that two disconnects be opened to de-energize all power to the unit. Treat all units as electrically energized until the convenience outlet power is also checked and de-energization is confirmed. Observe National Electrical Code Article 210, Branch Circuits, for use of convenience outlets.

Field Installed Option Thru-Base Connections

This service connection kit consists of a $\frac{1}{2}$ -in electrical bulkhead connector and a $\frac{3}{4}$ -in electrical bulkhead connector, all factory-installed in the embossed (raised) section of the unit basepan in the condenser section. The $\frac{1}{2}$ -in bulkhead connector enables the low-voltage control wires to pass through the basepan. The $\frac{3}{4}$ -in electrical bulkhead connector allows the high-voltage power wires to pass through the basepan. See Fig. 19.

Check tightness of connector lock nuts before connecting electrical conduits.

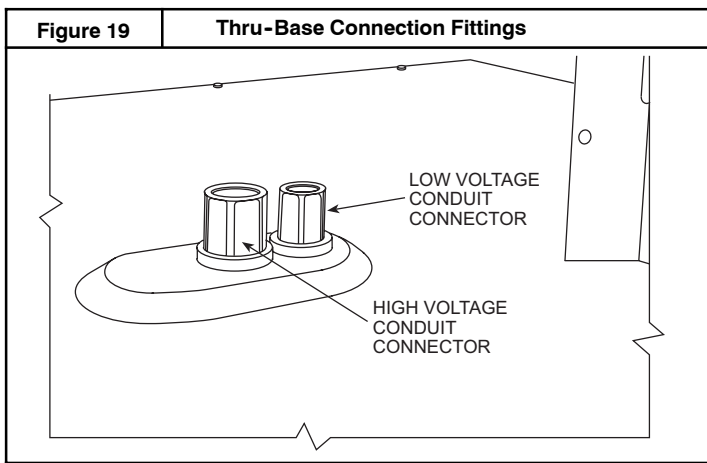

Field-supplied and field-installed liquidtight conduit connectors and conduit may be attached to the connectors on the basepan. Pull correctly rated high voltage and low voltage through appropriate conduits. Connect the power conduit to the internal disconnect (if unit is so equipped) or to the external disconnect (through unit side panel). A hole must be field cut in the main control box bottom on the left side so the 24-v control connections can be made. Connect the control power conduit to the unit control box at this hole.

Units Equipped With Thru-Base Connections

1. Install power wiring conduit through side panel openings. Install conduit between disconnect and control box.
2. Install power lines to terminal connections as shown in Fig. 16.

All Units

Voltage to compressor terminals during operation must be within voltage range indicated on unit nameplate. See Table 5. On 3-phase units, voltages between phases must be balanced within 2% and the current within 10%. Use the formula shown in the legend for Table 5, Note 2 to determine the percent of voltage imbalance. Operation on improper line voltage or excessive phase imbalance constitutes abuse and may cause damage to electrical components. Such operation would invalidate any applicable Bryant warranty.

Field Control Wiring

The RHS unit requires an external temperature control device. This device can be a thermostat emulation device provided as part of a third-party Building Management System.

Thermostat

Install an approved accessory 2 stage Cooling/Heating thermostat according to installation instructions included with the accessory. The RHS models do not require a thermostat with an O function to control the reversing valve operation. If using an electronic thermostat, configure it for “non-heat pump” operation. Locate the thermostat accessory on a solid wall in the conditioned space to sense average temperature in accordance with the thermostat installation instructions.

If the thermostat contains a logic circuit requiring 24-v power, use a thermostat cable or equivalent single leads of different colors with minimum of seven leads. If the thermostat does not require a 24-v source (no “C” connection required), use a thermostat cable or equivalent with minimum of six leads. Check the thermostat installation instructions for additional features which might require additional conductors in the cable.

For wire runs up to 50 ft. (15 m), use no. 18 AWG (American Wire Gage) insulated wire (35°C minimum). For 50 to 75 ft. (15 to 23 m), use no. 16 AWG insulated wire (35°C minimum). For over 75 ft. (23 m), use no. 14 AWG insulated wire (35°C minimum). All wire sizes larger than no. 18 AWG cannot be directly connected to the thermostat and will require a junction box and splice at the thermostat.

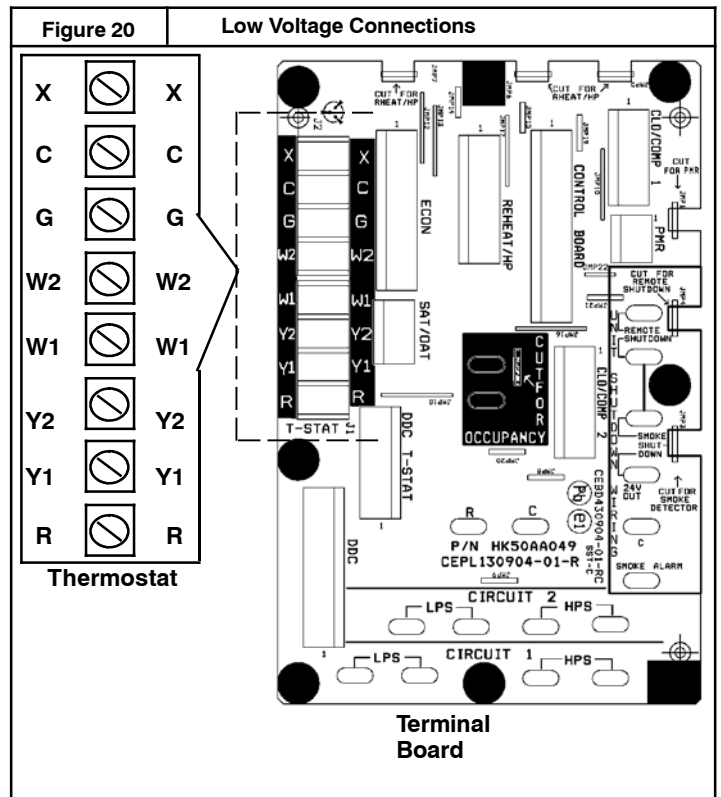

Unit without thru-base connection kit

Pass the thermostat control wires through the hole provided in the corner post; then feed the wires through the raceway built into the corner post to the control box. Pull the wires over to the terminal strip on the upper-left corner of the Central Terminal Board (CTB). See Fig. 21.

NOTE: If thru-the-bottom connections accessory is used, refer to the accessory installation instructions for information on routing power and control wiring.

Heat Anticipator Settings

Set heat anticipator settings at 0.14 amp for the first stage and 0.14 amp for second-stage heating, when available.

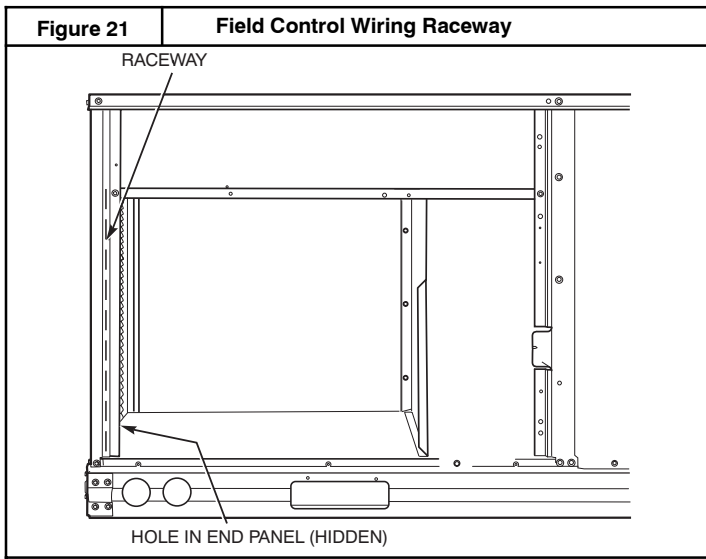

Not all available heater modules may be used in every unit. Use only those heater modules that are UL listed for use in a specific size unit. Refer to the label on the unit cabinet for the list of approved heaters.

Unit heaters are marked with Heater Model Numbers. But heaters are ordered as and shipped in cartons marked with a corresponding heater Sales Package part number. See Table 2 for correlation between heater Model Number and Sales Package part number.

NOTE: The value in position 9 of the part number differs between the sales package part number (value is 1 or 3) and a bare heater model number (value is 0).

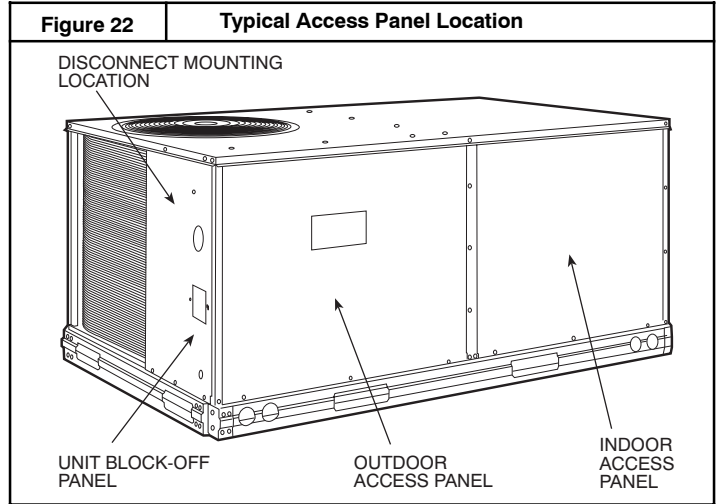

Electric Heaters

RHS units may be equipped with field-installed accessory electric heaters. The heaters are modular in design, with heater frames holding open coil resistance wires strung through ceramic insulators, line-break limit switches and a control contactor. One or two heater modules may be used in a unit.

Heater modules are installed in the compartment below the indoor (supply) fan outlet. Access is through the indoor access panel. Heater modules slide into the compartment on tracks along the bottom of the heater opening. See Fig. 22, Fig. 23 and Fig. 24.

Table 2 – Heater Model Number

Bare Heater Model Number	C	R	H	E	A	T	E	R	0	0	1	A	0	0
Heater Package Model Number Includes: Bare Heater Carton and packing materials Installation sheet	C	R	H	E	A	T	E	R	1	0	1	A	0	0

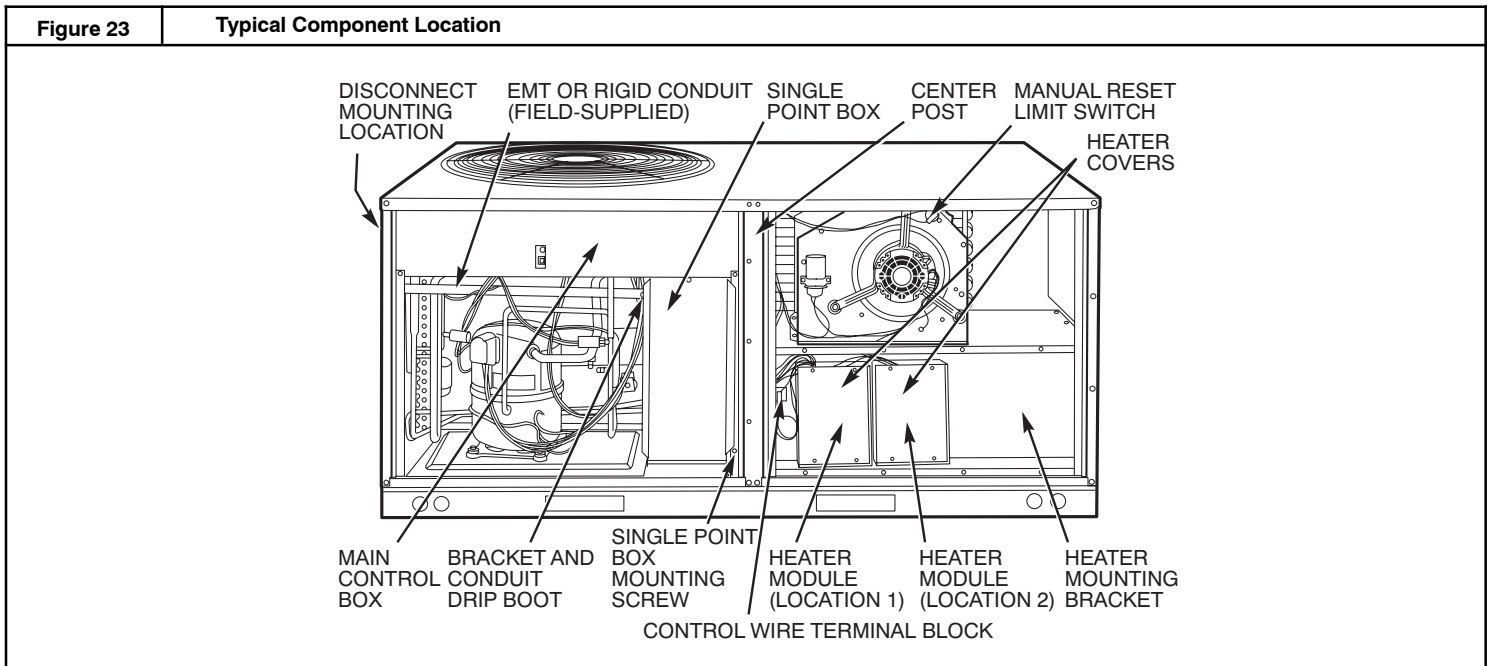
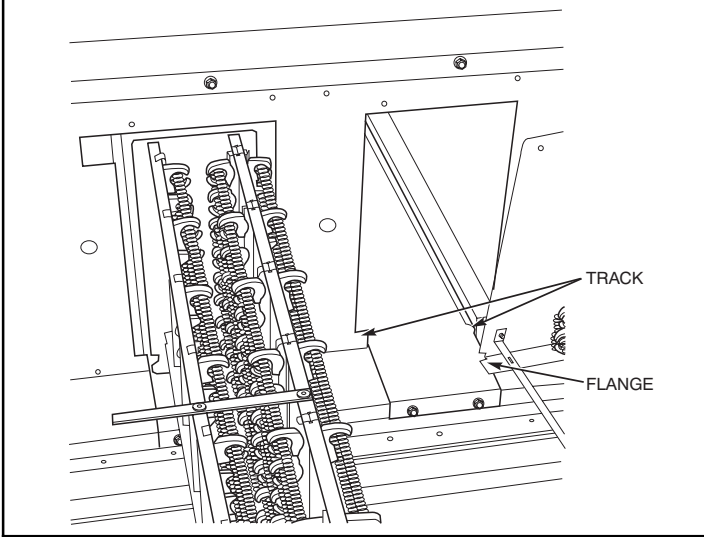
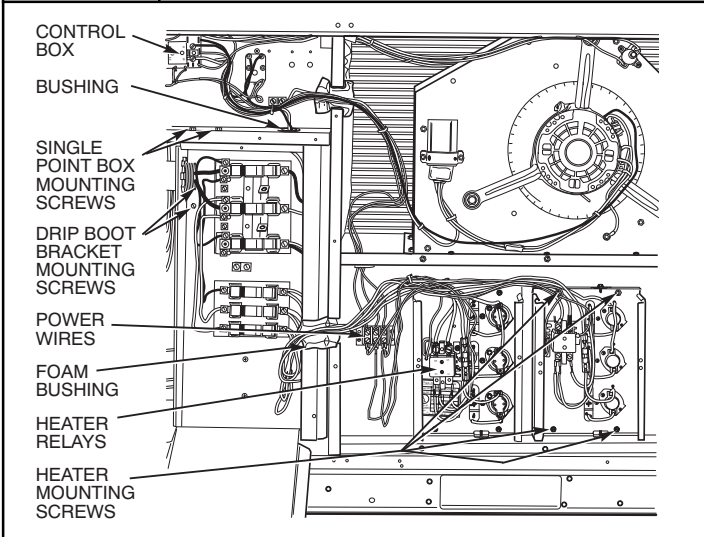

Figure 24 Typical Module Installation



Single Point Boxes and Supplementary Fuses — When the unit MOCB device value exceeds 60-A, unit-mounted supplementary fuses are required for each heater circuit. These fuses are included in accessory Single Point Boxes, with power distribution and fuse blocks. The single point box will be installed directly under the unit control box, just to the left of the partition separating the indoor section (with electric heaters) from the outdoor section. The Single Point Box has a hinged access cover. See Fig. 25. The Single Point Box also includes pigtailed to complete the wiring between the Single Point Box and the unit's main control box terminals. Refer to the accessory heater and Single Point Box installation instructions for details on tap connections

Figure 25 Typical Single Point Installation



All fuses on RHS units are 60-A. (Note that all heaters are qualified for use with a 60-A fuse, regardless of actual heater ampacity, so only 60-A fuses are necessary.)

Single Point Boxes without Fuses — Refer to accessory heater and Single Point Box installation instructions for details on tap connections.

Low-Voltage Control Connections — Run the low-voltage control leads from the heater module(s) - VIO and BRN (two of each if two modules are installed; identify for Module #1) - to the 4-pole terminal board TB4 located on the heater bulkhead to the left of Heater #1. Connect the VIO leads from Heater #1 and Heater #2 to terminal TB4-1. Connect the BRN leads to terminal TB4-3. See Fig. 26.

Figure 26 Accessory Electric Heater Control Connections

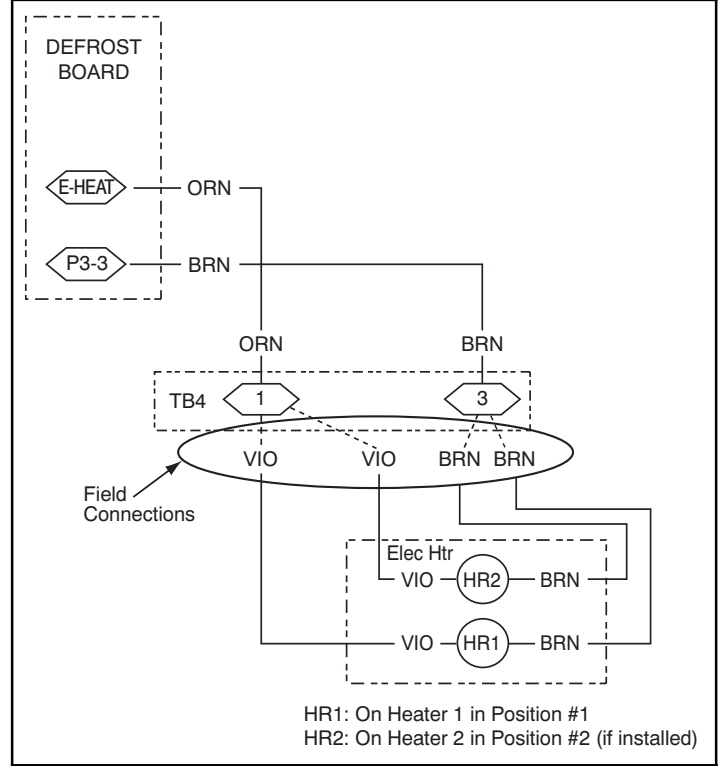

Figure 27 RHS Control Box Component Locations

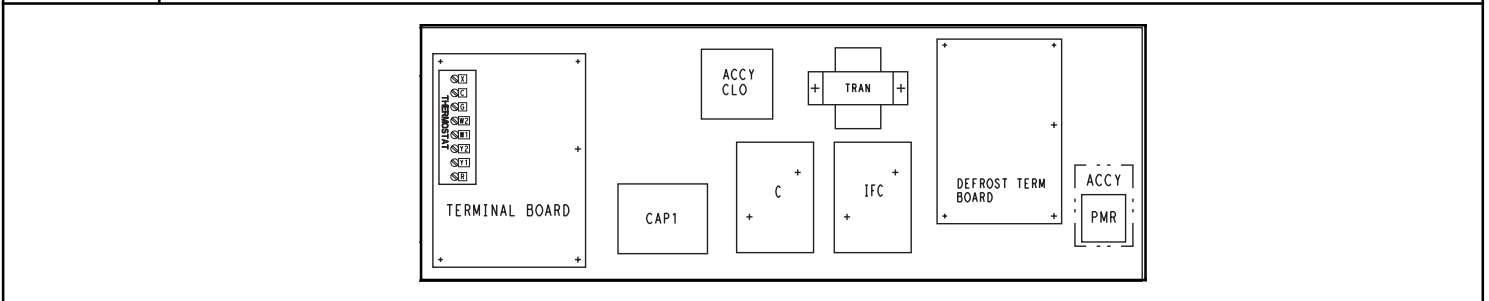

Table 5 – Unit Wire/MOCP Sizing Data

Unit RHS	Volt-Ph-Hz	IFM TYPE	ELECTRIC HEATER		NO C.O. or UNPWRD C.O.							
			Nom (kW)	FLA	NO P.E.				w/ P.E. (pwrd fr/unit)			
					MCA	MOCP	DISC. SIZE		MCA	MOCP	DISC. SIZE	
							FLA	LRA			FLA	LRA
036	208/230-1-60	STD	-	-	30.7	45	30	121	32.6	50	32	123
			3.3/4.4	15.9/18.3	50.6/53.6	60/60	48/51	137/139	52.5/55.5	60/60	51/53	139/141
			4.9/6.5	23.5/27.1	60.1/64.6	70/70	57/61	145/148	62.0/66.5	70/70	59/63	147/150
			6.5/8.7	31.4/36.3	69.9/76.1	70/80	66/72	152/157	71.8/78.0	80/80	68/74	154/159
			7.9/10.5	37.9/43.8	78.1/85.4	80/90	74/81	159/165	80.0/87.3	80/90	76/83	161/167
			9.8/13.0	46.9/54.2	89.3/98.4	90/100	84/92	215/229	91.2/100.3	100/110	86/95	217/231
	208/230-3-60	STD	-	-	24.8	30	25	97	26.7	30	27	99
			3.3/4.4	9.2/10.6	36.3/38.1	45/45	35/37	106/108	38.2/40.0	45/50	37/39	108/110
			4.9/6.5	13.6/15.6	41.8/44.3	50/50	40/43	111/113	43.7/46.2	50/50	43/45	113/115
			6.5/8.7	18.1/20.9	47.4/50.9	50/60	46/49	115/118	49.3/52.8	50/60	48/51	117/120
			7.9/10.5	21.9/25.3	52.2/56.4	60/60	50/54	119/122	54.1/58.3	60/60	52/56	121/124
			12.0/16.0	33.4/38.5	66.6/72.9	70/80	63/69	130/136	68.5/74.8	70/80	65/71	132/138
		MED*	-	-	22.6	30	22	109	24.5	30	24	111
			3.3/4.4	9.2/10.6	34.1/35.9	45/45	33/34	118/120	36.0/37.8	45/45	35/37	120/122
			4.9/6.5	13.6/15.6	39.6/42.1	45/50	38/40	123/125	41.5/44.0	50/50	40/42	125/127
			6.5/8.7	18.1/20.9	45.2/48.7	50/50	43/46	127/130	47.1/50.6	50/60	45/48	129/132
			7.9/10.5	21.9/25.3	50.0/54.2	50/60	47/51	131/134	51.9/56.1	60/60	50/53	133/136
			12.0/16.0	33.4/38.5	64.4/70.7	70/80	61/66	142/148	66.3/72.6	70/80	63/69	144/150
		HIGH	-	-	22.6	30	22	120	24.5	30	24	122
			3.3/4.4	9.2/10.6	34.1/35.9	45/45	33/34	129/131	36.0/37.8	45/45	35/37	131/133
			4.9/6.5	13.6/15.6	39.6/42.1	45/50	38/40	134/136	41.5/44.0	50/50	40/42	136/138
			6.5/8.7	18.1/20.9	45.2/48.7	50/50	43/46	138/141	47.1/50.6	50/60	45/48	140/143
			7.9/10.5	21.9/25.3	50.0/54.2	50/60	47/51	142/145	51.9/56.1	60/60	50/53	144/147
			12.0/16.0	33.4/38.5	64.4/70.7	70/80	61/66	153/159	66.3/72.6	70/80	63/69	155/161
	460-3-60	STD	-	-	16.0	20	16	53	17.0	20	17	54
			6.0	7.2	25.0	30	24	60	26.0	30	26	61
			8.8	10.6	29.3	30	28	64	30.3	35	30	65
			11.5	13.8	33.3	35	32	67	34.3	35	33	68
14.0			16.8	37.0	40	36	70	38.0	40	37	71	
MED*		-	-	10.6	15	10	54	11.6	15	12	55	
		6.0	7.2	19.6	20	19	61	20.6	25	20	62	
		8.8	10.6	23.9	25	23	65	24.9	25	24	66	
		11.5	13.8	27.9	30	26	68	28.9	30	27	69	
		14.0	16.8	31.6	35	30	71	32.6	35	31	72	
HIGH		-	-	10.6	15	10	60	11.6	15	12	61	
		6.0	7.2	19.6	20	19	67	20.6	25	20	68	
	8.8	10.6	23.9	25	23	71	24.9	25	24	72		
	11.5	13.8	27.9	30	26	74	28.9	30	27	75		
575-3-60	STD	-	-	5.4	15	5	5	7.4	20	15	7	
	MED	-	-	3.4	15	3	8	5.4	20	15	10	
	HIGH	-	-	2.9	15	3	12	4.9	20	15	14	

MED Static motor available from Fast Parts

NOTE: See page 19 for table legend and notes.

Table 5 — Unit Wire/MOCP Sizing Data (cont)

Unit RHS	Volt-Ph-Hz	IFM TYPE	ELECTRIC HEATER		NO C.O. or UNPWRD C.O.							
			Nom (kW)	FLA	NO P.E.				w/ P.E. (pwrd fr/unit)			
					MCA	MOCP	DISC. SIZE		MCA	MOCP	DISC. SIZE	
							FLA	LRA			FLA	LRA
048	208/230-1-60	STD	-	-	36.2	50	35	128	38.1	50	37	130
			3.3/4.4	15.9/18.3	56.0/59.0	60/60	54/56	144/146	57.9/60.9	60/70	56/59	146/148
			6.5/8.7	31.4/36.3	75.4/81.5	80/90	71/77	159/164	77.3/83.4	80/90	74/79	161/166
			9.8/13.0	46.9/54.2	94.8/103.9	100/110	89/98	222/236	96.7/105.8	100/110	91/100	224/238
			13.1/17.4	62.8/72.5	114.7/126.8	125/150	108/119	254/273	166.6/128.7	125/150	110/121	256/275
			15.82/1.0	75.8/87.5	130.9/145.5	150/150	122/136	280/303	132.8/147.4	150/150	125/138	282/305
	208/230-3-60	STD	-	-	26.0	30	26	94	27.9	40	28	96
			4.9/6.5	13.6/15.6	43.0/45.5	50/50	42/44	108/110	44.9/47.4	50/50	44/46	110/112
			6.5/8.7	18.1/20.9	48.7/52.2	50/60	47/50	112/115	50.6/54.1	60/60	49/52	114/117
			12.0/16.0	33.4/38.5	67.8/74.2	70/80	64/70	127/133	69.7/76.1	70/80	67/72	129/135
			15.8/21.0	43.8/50.5	80.8/98.2	90/90	76/84	182/195	82.7/91.1	90/100	79/86	184/197
		MED*	-	-	23.8	30	23	106	25.7	30	26	108
			4.9/6.5	13.6/15.6	40.8/43.3	50/50	39/41	120/122	42.7/45.2	50/50	41/44	122/124
			6.5/8.7	18.1/20.9	46.5/50.0	50/50	44/47	124/127	48.4/51.9	50/60	46/50	126/129
			12.0/16.0	33.4/38.5	65.6/72.0	70/80	62/68	139/145	67.5/73.9	70/80	64/70	141/147
			15.8/21.0	43.8/50.5	78.6/87.0	80/90	74/82	194/207	80.5/88.9	90/90	76/84	196/209
		HIGH	-	-	23.8	30	23	117	25.7	30	26	119
			4.9/6.5	13.6/15.6	40.8/43.3	50/50	39/41	131/133	42.7/45.2	50/50	41/44	133/135
	6.5/8.7		18.1/20.9	46.5/50.0	50/50	44/47	135/138	48.4/51.9	50/60	46/50	137/140	
	12.0/16.0		33.4/38.5	65.6/72.0	70/80	62/68	150/156	67.5/73.9	70/80	64/70	152/158	
	15.8/21.0		43.8/50.5	78.6/87.0	80/90	74/82	202/218	80.5/88.9	90/90	76/84	207/220	
	460-3-60	STD	-	-	16.5	20	17	51	17.5	25	18	52
			6.0	7.2	25.5	30	25	58	26.5	30	26	59
			11.5	13.8	33.8	35	33	65	34.8	35	34	66
			14.0	16.8	37.5	40	36	68	38.5	40	37	69
			23.0	27.7	51.1	60	49	106	52.1	60	50	107
		MED*	-	-	11.2	15	11	52	12.2	15	12	53
			6.0	7.2	20.2	25	19	59	21.2	25	20	60
11.5			13.8	28.4	30	27	66	29.4	30	28	67	
14.0			16.8	32.2	35	30	69	33.2	35	32	70	
23.0			27.7	45.8	50	43	107	46.8	50	44	108	
HIGH		-	-	11.2	15	11	58	12.2	15	12	59	
		6.0	7.2	20.2	25	19	65	21.2	25	20	66	
		11.5	13.8	28.4	30	27	72	29.4	30	28	73	
		14.0	16.8	32.2	35	30	75	33.2	35	32	76	
		23.0	27.7	45.8	50	43	113	46.8	50	44	114	
575-3-60	STD	-	-	10.6	15	11	43	12.5	15	13	45	
	MED	-	-	9.0	15	9	46	10.9	15	11	48	
	HIGH	-	-	8.6	15	9	50	10.5	15	11	52	

MED Static motor available from Fast Parts

NOTE: See page 19 for table legend and notes.

Table 5 — Unit Wire/MOCP Sizing Data (cont)

Unit RHS	Volt-Ph-Hz	IFM TYPE	ELECTRIC HEATER		NO C.O. or UNPWRD C.O.							
			Nom (kW)	FLA	NO P.E.				w/ P.E. (pwrd fr/unit)			
					MCA	MOCP	DISC. SIZE		MCA	MOCP	DISC. SIZE	
							FLA	LRA			FLA	LRA
060	208/230-60	STD	-	-	41.7	60	40	145	43.6	60	43	147
			4.9/6.5	23.5/27.1	71.0/75.5	80/80	67/72	169/172	72.9/77.4	80/80	70/74	171/174
			6.5/8.7	31.4/36.3	80.9/87.0	90/100	76/82	176/181	82.8/88.9	100/100	79/84	178/183
			9.8/13.0	46.9/54.2	100.3/109.4	110/110	94/103	239/253	102.2/111.3	110/125	96/105	241/255
			13.1/17.4	62.8/72.5	120.2/132.3	125/150	113/124	271/290	122.1/134.2	125/150	115/126	273/292
			15.821.0	75.8/87.5	136.4/151.0	150/175	128/141	297/320	138.3/152.9	150/175	130/143	299/322
	208/230-3-60	STD	-	-	28.4	40	28	121	30.3	45	30	123
			4.9/6.5	13.6/15.6	45.4/47.9	50/50	44/46	135/137	47.3/49.8	50/60	46/48	137/139
			7.9/10.5	21.9/25.3	55.8/60.0	60/70	53/57	143/146	57.7/61.9	60/70	56/59	145/148
			12.0/16.0	33.4/38.5	70.2/76.5	80/80	67/72	154/160	72.1/78.4	80/80	69/75	156/162
			15.8/21.0	43.8/50.5	83.2/91.5	90/100	79/86	209/222	85.1/93.4	90/100	81/88	211/224
			19.9/26.5	55.2/63.8	97.4/108.2	100/110	92/102	231/249	99.3/110.1	100/125	94/104	233/251
		MED*	-	-	26.2	40	26	144	28.1	40	28	146
			4.9/6.5	13.6/15.6	43.2/45.7	50/50	41/44	158/160	45.1/47.6	50/50	43/46	160/162
			7.9/10.5	21.9/25.3	53.6/57.8	60/60	51/55	166/169	55.5/59.7	60/60	53/57	168/171
			12.0/16.0	33.4/38.5	68.0/74.3	70/80	64/70	177/183	69.9/76.2	70/80	66/72	179/185
			15.8/21.0	43.8/50.5	81.0/89.3	90/90	76/84	232/245	82.9/91.2	90/100	78/86	234/247
			19.9/26.5	55.2/63.8	95.2/106.0	100/110	89/99	254/272	97.1/107.9	100/110	91/101	256/274
	HIGH	-	-	28.5	40	28	170	30.4	45	30	172	
		4.9/6.5	13.6/15.6	45.5/48.0	50/50	44/46	184/186	47.4/49.9	50/60	46/48	186/188	
		7.9/10.5	21.9/25.3	55.9/60.1	60/70	53/57	192/195	57.8/62.0	60/70	56/60	194/197	
		12.0/16.0	33.4/38.5	70.3/76.6	80/90	67/73	203/209	72.2/78.5	80/80	69/75	205/211	
		15.8/21.0	43.8/50.5	83.3/91.6	90/100	79/86	258/271	85.2/93.5	90/100	81/89	260/273	
		19.9/26.5	55.2/63.8	97.5/108.3	100/110	92/102	280/298	99.4/110.2	100/125	94/104	282/300	
	460-3-60	STD	-	-	18.0	25	19	62	19.0	25	20	63
			6.0	7.2	27.0	30	27	69	28.0	30	28	70
			11.5	13.8	35.3	40	34	76	36.3	40	36	77
			14.0	16.8	39.0	40	38	79	40.0	45	39	80
23.0			27.7	52.7	60	50	117	53.7	60	52	118	
25.5			30.7	56.4	60	54	123	57.4	60	55	124	
MED*		-	-	13.0	20	13	69	14.0	20	14	70	
		6.0	7.2	22.0	25	21	76	23.0	25	22	77	
		11.5	13.8	30.3	35	29	83	31.3	35	30	84	
		14.0	16.8	34.0	35	32	86	35.0	40	33	87	
		23.0	27.7	47.7	50	45	124	48.7	50	46	125	
		25.5	30.7	51.4	50	48	130	52.4	60	49	131	
HIGH		-	-	13.8	20	14	82	14.8	20	15	83	
		6.0	7.2	22.8	25	22	89	23.8	25	23	90	
		11.5	13.8	31.1	35	30	96	32.1	35	31	97	
		14.0	16.8	34.8	35	33	99	35.8	40	34	100	
		23.0	27.7	48.5	50	46	137	49.5	50	47	138	
		25.5	30.7	52.2	60	49	143	53.2	60	50	144	
575-3-60	STD	-	-	11.9	15	12	45	13.8	20	14	47	
	MED*	-	-	9.9	15	10	52	11.8	15	12	54	
	HIGH	-	-	10.7	15	11	63	12.6	15	13	65	

MED Static motor available from Fast Parts

NOTE: See page 19 for table legend and notes.

Table 5 — Unit Wire/MOCP Sizing Data (cont)

Unit RHS	Volt.-Ph-Hz	IFM TYPE	ELECTRIC HEATER		NO C.O. or UNPWRD C.O.							
			Nom (kW)	FLA	NO P.E.				w/ P.E. (pwrd fr/unit)			
					MCA	MOCP	DISC. SIZE		MCA	MOCP	DISC. SIZE	
							FLA	LRA			FLA	LRA
072	208/230-3-60	STD	-	-	30.5	45	30	146	32.4	50	32	148
			4.9/6.5	13.6/15.6	47.5/50.0	60/60	45/47	160/162	49.4/51.9	60/60	47/50	162/164
			7.9/10.5	21.9/25.3	57.8/62.1	60/70	55/59	168/171	59.7/64.0	60/70	57/61	170/173
			12.0/16.0	33.4/38.5	72.2/78.6	80/80	68/74	179/185	74.1/80.5	80/90	70/76	181/187
			15.8/21.0	43.8/50.5	85.2/93.6	90/100	80/88	234/247	87.1/95.5	90/100	82/90	236/249
			19.9/26.5	55.2/63.8	99.5/110.2	100/125	93/103	256/274	101.4/112.1	110/125	95/105	258/276
		MED*	-	-	32.8	50	32	183	34.7	50	34	185
			4.9/6.5	13.6/15.6	49.8/52.3	60/60	48/50	197/199	51.5/54.2	60/60	50/52	199/201
			7.9/10.5	21.9/25.3	60.1/64.4	70/70	57/61	205/208	62.0/66.3	70/70	60/63	207/210
			12.0/16.0	33.4/38.5	74.5/80.9	80/90	71/76	216/222	76.4/82.8	80/90	73/79	218/224
			15.8/21.0	43.8/50.5	87.5/95.9	90/100	83/90	271/284	89.4/97.8	90/100	85/92	273/286
			19.9/26.5	55.2/63.8	101.8/112.5	110/125	96/106	293/311	103.7/114.4	110/125	98/108	295/313
	HIGH	-	-	32.8	50	32	183	34.7	50	34	185	
		4.9/6.5	13.6/15.6	49.8/52.3	60/60	48/50	197/199	51.7/54.2	60/60	50/52	199/201	
		7.9/10.5	21.9/25.3	60.1/64.4	70/70	57/61	205/208	62.0/66.3	70/70	60/63	207/210	
		12.0/16.0	33.4/38.5	74.5/80.9	80/90	71/76	216/222	76.4/82.8	80/80	73/79	218/224	
		15.8/21.0	43.8/50.5	87.5/95.9	90/100	83/90	271/284	89.4/97.8	90/100	85/92	273/286	
		19.9/26.5	55.2/63.8	101.8/112.5	110/125	96/106	293/311	103.7/114.4	110/125	98/108	295/313	
	460-3-60	STD	-	-	15.5	25	15	73	16.5	25	16	74
			6.0	7.2	24.4	30	23	80	25.5	30	24	81
			11.5	13.8	32.8	35	31	87	33.8	40	32	88
			14.0	16.8	36.5	40	34	90	37.5	40	36	91
			23.0	27.7	50.2	60	47	128	51.2	60	48	129
			25.5	30.7	53.9	60	50	134	54.9	60	52	135
MED*		-	-	16.3	25	16	92	17.3	25	17	93	
		6.0	7.2	25.3	30	24	99	26.3	30	25	100	
		11.5	13.8	33.6	35	32	106	34.6	40	33	107	
		14.0	16.8	37.3	40	35	109	38.3	40	36	110	
		23.0	27.7	51.0	60	48	147	52.0	60	49	148	
		25.5	30.7	54.7	60	51	153	55.7	60	52	154	
HIGH		-	-	16.3	25	16	92	17.3	25	17	93	
		6.0	7.2	25.3	30	24	99	26.3	30	25	100	
		11.5	13.8	33.6	35	32	106	34.6	40	33	107	
		14.0	16.8	37.3	40	35	109	38.3	40	36	110	
		23.0	27.7	51.0	60	48	147	52.0	60	49	148	
		25.5	30.7	54.7	60	51	153	55.7	60	52	154	
575-3-60	STD	-	-	12.3	15	12	59	14.2	20	14	61	
	MED	-	-	12.7	20	12	74	14.6	20	15	76	
	HIGH	-	-	12.7	20	12	74	14.6	20	15	76	

MED Static motor available from Fast Parts

NOTE: See page 19 for table legend and notes.

Legend and Notes for Table 5

LEGEND:

- CO - Convenient outlet
- DISC - Disconnect
- FLA - Full load amps
- IFM - Indoor fan motor
- LRA - Locked rotor amps
- MCA - Minimum circuit amps
- MOCP - Maximum over current protection
- PE -



- Power exhaust
- UNPWR CO - Unpowered convenient outlet

NOTES:

1. In compliance with NEC requirements for multimotor and combination load equipment (refer to NEC Articles 430 and 440), the overcurrent protective device for the unit shall be fuse or HACR breaker. Canadian units may be fuse or circuit breaker.
2. **Unbalanced 3-Phase Supply Voltage**
Never operate a motor where a phase imbalance in supply voltage is greater than 2%. Use the following formula to determine the percentage of voltage imbalance.

$$\% \text{ Voltage Imbalance} = 100 \times \frac{\text{max voltage deviation from average voltage}}{\text{average voltage}}$$

Example: Supply voltage is 230-3-60



- AB = 224 v
- BC = 231 v
- AC = 226 v

$$\text{Average Voltage} = \frac{(224 + 231 + 226)}{3} = \frac{681}{3} = 227$$

Determine maximum deviation from average voltage.

(AB) $227 - 224 = 3 \text{ v}$

(BC) $231 - 227 = 4 \text{ v}$

(AC) $227 - 226 = 1 \text{ v}$

Maximum deviation is 4 v.

Determine percent of voltage imbalance.

$$\% \text{ Voltage Imbalance} = 100 \times \frac{4}{227} = 1.76\%$$

This amount of phase imbalance is satisfactory as it is below the maximum allowable 2%.

IMPORTANT: If the supply voltage phase imbalance is more than 2%, contact your local electric utility company immediately.

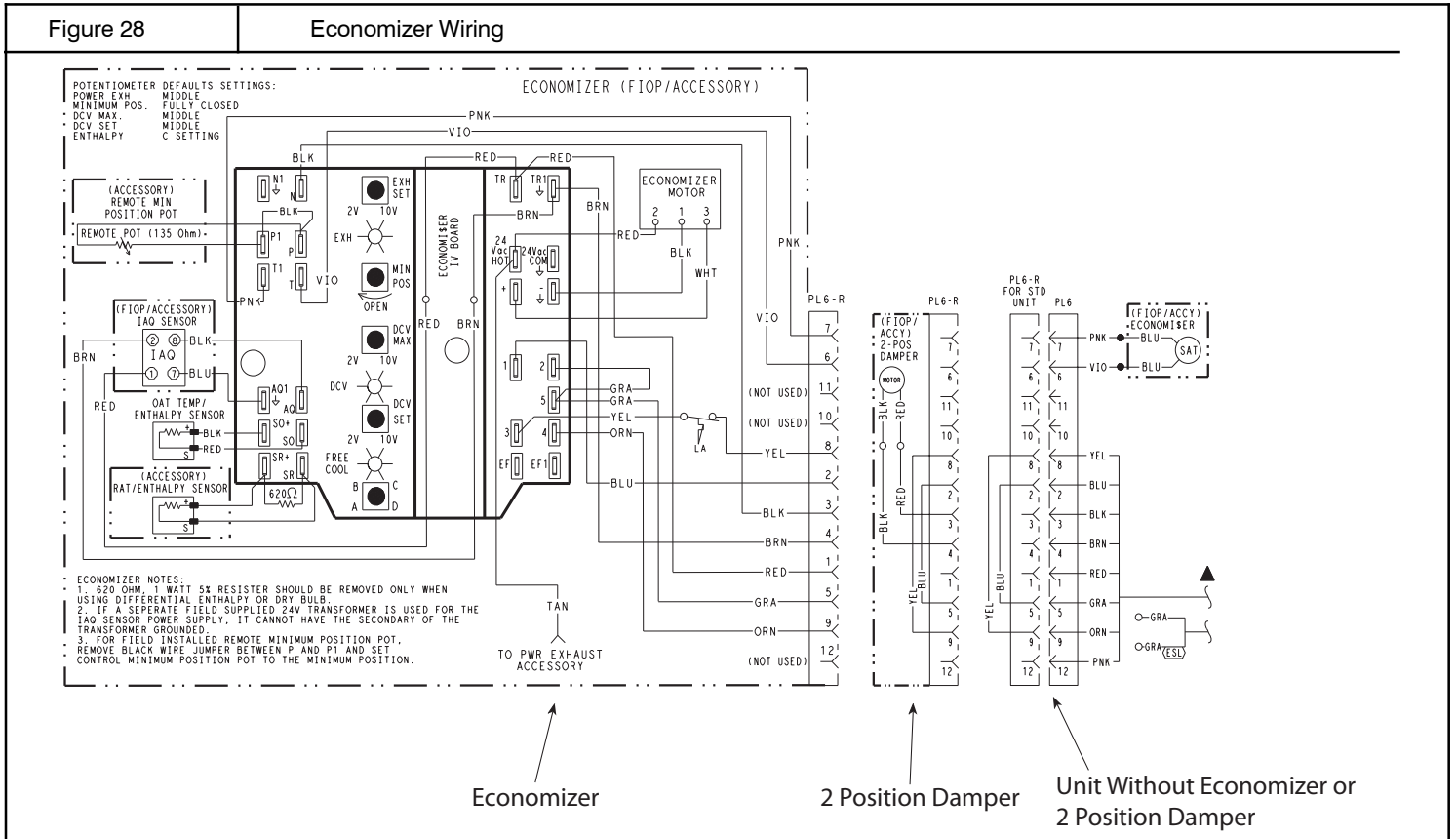

Step 11 — Adjust Factory-Installed Options

Smoke Detectors

Smoke detector(s) will be connected at the Central Terminal Board (CTB), at terminals marked “Smoke Shutdown”. Remove jumper JMP 3 when ready to energize unit.

Economizer Occupancy Switch

Refer to Fig. 28 for general Economizer wiring. External occupancy control is managed through a connection on the Central Terminal Board.

If external occupancy control is desired, connect a time clock or remotely controlled switch (closed for Occupied, open for Unoccupied sequence) at terminals marked OCCUPANCY on CTB. Remove or cut jumper JMP 2 to complete the installation.

Step 12 — Install Accessories

Available accessories include:

- Roof Curb
- Thru-base connection kit (must be installed before unit is set on curb)
- Manual outside air damper
- Two-Position motorized outside air damper
- Power Exhaust
- Outdoor enthalpy sensor
- Differential enthalpy sensor
- Electric Heaters
- Single Point kits
- CO₂ sensor
- Phase monitor control

Refer to separate installation instructions for information on installing these accessories.

Pre-Start and Start-Up

This completes the mechanical installation of the unit. Refer to the unit's Service Manual for detailed Pre-Start and Start-up instructions.